400 SERIES GRAYHOUND
Remix Asphalt Paver
Operation/Maintenance Manual



To the Owner & Operator

We have tried to provide information which will give you a clear understanding of equipment construction, function, capabilities and requirements. This information is based on the knowledge and experience of highly qualified people at our company and in our field organization. Proper use of this information will promote high efficiency, maximum service life and low maintenance costs.

We strongly recommend that all persons directly involved with this equipment be familiar with this manual.

The information contained in this manual should not be considered all-inclusive for every application. Questions about specific uses of this equipment should be directed to Cedarapids Inc. Anyone who uses this equipment for any purposes other than its intended use assumes the risk of any danger in doing so.

Respectfully,

Cedarapids Inc.



Warning - The operators of this equipment must read, understand, and follow all OSHA, federal, state and local regulations regarding the operation of this equipment. This equipment must be used in accordance with all operation and maintenance instructions.

- (1) Read all decals and instruction signs. Know what guards and protective devices are included and see that each is installed and in operational condition. Additional guards and protective devices may be required and must be installed before operating.
- (2) Never maintain, lubricate or adjust equipment while in operation. Turn off key switch and remove the key before doing any maintenance, lubricating, or adjusting. In some cases it may be necessary to disconnect the battery terminals to prevent accidental starting of the equipment.
- (3) Wear a protective mask whenever harmful air pollution exists.
- (4) Use ear plugs whenever noise level is above established limits.

The following warning applies to Cedarapids equipment supplied with lead-acid batteries:



Warning: Battery posts, terminals and related accessories contain lead and lead compounds, chemicals known to the State of California to cause cancer and reproductive harm.

Wash hands after handling.

Table Of Contents

Section 1 -Introduction	1-1
Cedarapids Paver Manuals	1-1
Hazard Levels	1-2
Identification Number Location	1-3
Lockout Tagout	1-7
General safety	1-8
Receiving New Equipment	1-10
Section 2 -Equipment Description	2-1
Function and Application	2-1
Optional Equipment	2-3
Operator's Console	2-8
Section 3 -Periodic Maintenance	3-1
Raising the hood	3-1
Before Starting Engine	3-2
Maintenance Checklist	3-3
Periodic Maintenance	3-5
1) Fuel Level	3-5
2) Fuel/Water Separator	3-5
3) Travel Lever Alignment	3-6
4) Hydraulic Fluid	3-6
5) Oil Cooler	3-7
6) Suction Strainers	3-7
7) Charge Filters	3-8
8) Auxiliary Pump Filter	3-8
9) Hydraulic lines and components	3-8
10) Air Restriction Indicator	3-8
11) Air Filter	3-9
12) Engine Oil	3-10
13) Engine Oil Filter	3-11
14) Engine Coolant	3-11
15) Engine Fan Belt	3-12
16) Radiator	3-13
17) Engine Cooling Fan	3-13
18) Battery	3-13
19) Tire Pressure	3-15

Table Of Contents

20) Frame Raise System	3-16
21) Steel Track Tension	3-17
21A) Rubber Track Tension	3-19
22) Track Pivot	3-19
23) Fire Extinguisher	3-19
24) Horn	3-19
25) Pump Drive Belts	3-19
26) Depth Cranks	3-22
27) Vibrator Bearings	3-22
28) Crown Control	3-22
29) Match Height Assembly	3-23
30) Extension Slope Assembly	3-23
31) Final Drive Oil	3-23
32) Steering Bogie Alignment	3-23
33) Steering Linkage	3-24
34) Bogie Beam Bearings	3-24
35) Front Wheel Bearings	3-24
36) Bogie Wheel Toe-in	3-24
37) Delivery Auger Clearance	3-25
38) Delivery Auger Drive - Gear Drive	3-26
39) Front Delivery Auger Bearings	3-26
40) Spreading Auger Bearings	3-26
41) Spreading Auger Drive Chains	3-27
42) Spreading Auger Speed Reducer	3-27
43) Hood Raise Reservoir	3-28
44) Operator Console Pivot Bearings	3-28
45) Tow Arm Nose Roller	3-28
46) Slope Beam Rod Ends	3-28
47) Truck Hitch	3-29
48) Fume Recovery System	3-29
Section 4 -Operating the Tractor	4-1
Starting the Engine	4-1
Engine start-up after stall	4-2
Jump starting/ charging batteries	4-2
Emergency towing	4-3

Table Of Contents

Loading/Unloading	4-5
Driving the Paver off a Trailer	4-5
Lifting with crane	4-6
Preparation for transport	4-8
Preparing to Pave	4-9
Rubber Track Operating Hints	4-13
Do Not Allow Asphalt Build-up on Track	4-13
Proper Installation of Material Retaining Plates	4-14
Maneuvering On Hot Asphalt	4-15
Maneuvering On Uneven Surface	4-17
Maintenance of Track	4-19
Spray Down and Cleaning	4-23
Paver Cleaning Procedure	4-23
Generation III Sonic Sensor Cleaning	4-24
Pressure Cleaning	4-24
 Section 5 -Hydraulic System	5-1
General Description	5-1
Fluid Temperature	5-1
Fluid Reservoirs:	5-1
Delivery Auger Pumps	5-2
Delivery Auger Drive Systems	5-2
High Pressure Adjustment	5-2
Travel Pumps	5-4
Travel Drive Systems	5-4
Checking System Relief Setting	5-4
System High Pressure Relief Valve Replacement	5-5
Travel Neutral Adjustment	5-6
Spreading Auger Pumps	5-9
Spreading Auger Drive Systems	5-9
Checking System Relief Setting	5-9
System High Pressure Relief Valve Replacement	5-10
Spreading Auger Neutral Adjustment	5-11

Table Of Contents

Remix Delivery Control	5-14
Delivery Control Components	5-14
Remix Delivery Control Operation	5-15
Remix Delivery Control Troubleshooting	5-15
Vibrator Pump	5-17
Auxiliary Systems Pump	5-18
Auxiliary System	5-18
Auxiliary System Pressure Compensator Check	5-18
Rubber Track Hydraulic System	5-19
Checking Rubber Track Hydraulic System	5-21
Auxiliary System Pump Pressure	5-21
Pressure Reducing Valves	5-21
Track Tension Accumulator	5-22
Track Tension Check Valve and Release Valve	5-22
Track Tensioning Cylinders	5-23
Track Take-up Valve	5-24
Filters	5-25
Charge Filter Replacement	5-25
Auxiliary Filter	5-25
Suction Strainers	5-26
Solenoid Valves	5-27
Manual Testing of Solenoid Valves	5-29
Removing/disassembling Valve Bank	5-29
Valve Bank Components	5-30
Throttle Valve	5-30
Holding Valve	5-30
Flow Control Valve	5-30
Assembling Valve Banks	5-31
Hydraulic System Troubleshooting	5-33
Hydraulic Fluid Overheating	5-33
Failing Pumps or Motors	5-33
Air in the Systems	5-33
Causes of Air in System	5-33
Locating Air Leaks	5-34

Table Of Contents

Section 6 -Mechanical Maintenance	6-1
Steel Track Maintenance	6-1
Steel Track Tensioning	6-1
Steel Track over-pressurizing	6-2
Steel Track Relief Pressure	6-3
Steel Track Installation	6-3
Steel Track Removal	6-4
Replacing Steel Track Drive Sprockets	6-4
Repairing Oscillating Bogie Rollers	6-5
Rubber Track Maintenance	6-6
Rubber Track Tension	6-6
Rubber Track Installation & Removal	6-6
Rubber Track Re-tensioning	6-8
Repairing Rubber Track Bogie Wheels	6-9
Bogie Wheel Bearing Replacement	6-10
Repairing Rubber Track Front Idler Assembly	6-12
Bearing Replacement	6-15
Rubber Track Drive Wheel Replacement	6-17
Delivery Augers	6-18
Replacing Auger Liners	6-18
Replacing Auger Flights	6-18
Spreading Augers	6-19
Cast Augers	6-19
Machine Storage Preparation	6-20
Appendix A -Torque Specs	A-1
Torque Charts	A-1
Section 7 - Automation (if equipped)	
Section 8 - Screed (if equipped)	
Index	I-1

Cedarapids Paver Manuals

Section 1 - Introduction

Cedarapids Paver Manuals

The following list represents the complete set of manuals available to the owner, operator, and mechanic of a Grayhound paver. All of these manuals are included with each new paver when it ships from the factory. If your manuals are not included with your new paver or if you require additional copies of any of these manuals contact your local Cedarapids dealer.

Operation and Maintenance Manual

The Operation and Maintenance manual is intended to be used by both the operator and mechanic.

The operation portion of this manual gives detailed operating and safety instructions for both new and experienced operators. It is intended to give more detailed information than the Pocket Paver Guide.

The maintenance portion of this manual gives detailed information on component locations, test procedures, safety, and routine maintenance. This information expands on the information in Technical manual and Wear Check Guide.

Technical Manual

The Technical manual is designed primarily for use by maintenance personnel. It provides detailed troubleshooting procedures and schematics for diagnosing paver breakdowns. Once a problem has been diagnosed, refer to the Operation and Maintenance manual for information on making the repair.

Quality Paving Guide

The Quality Paving Guide should be used primarily by paver operators. This manual gives detailed information on setting up the paver to produce the mat surface needed.

Wear Check Guide

The Wear Check Guide should be used primarily by maintenance personnel. It contains detailed information for determining when parts require replacement.

About the Pocket Paver Guide

The Pocket Paver Guide is a small reference manual designed for use by experienced operators. It contains information needed by the operator for day-to-day operation, adjustment and maintenance of the paver and screed.

CIMA Safety Manual

The CIMA Safety Manual is a general manual designed to be used by everyone on a paving job site. This would include operators, laborers, mechanics, truck drivers, etc.

Hazard Levels

Hazard Levels

The signal words **Danger**, **Warning** and **Caution** are used to identify hazard levels of in this manual. They may also be found on decals located on the equipment. (Figure 1 - 1)

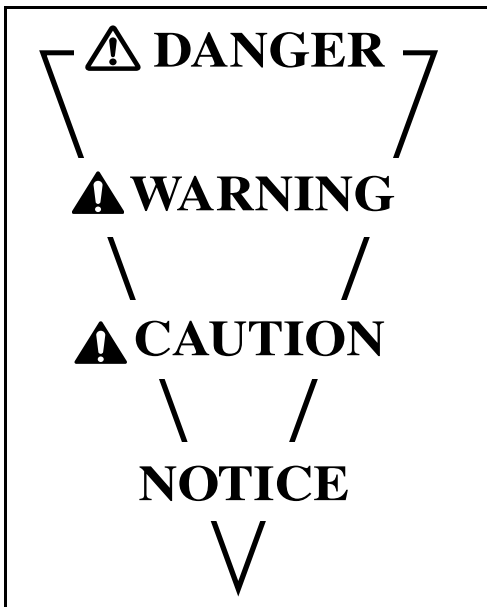

Figure 1 - 1 Hazard Level Hierarchy

Definitions for identifying hazard levels and their signal words are provided below:



Danger - Immediate hazards which **WILL** result in death, system loss, severe personal injury, severe occupational illness or severe or major system or environmental damage.



Warning - Hazards or unsafe practices which **COULD** result in death, system loss, severe personal injury, severe occupational illness or severe or major system or environmental damage.



Caution - Hazards or unsafe practices which **COULD** result in minor personal injury, minor occupational illness, or minor system or environmental damage.

The signal word **Notice** is used to identify installation, operation, or maintenance information which is important but not hazard related.

Identification Number Location

Identification Number Location

Tractor

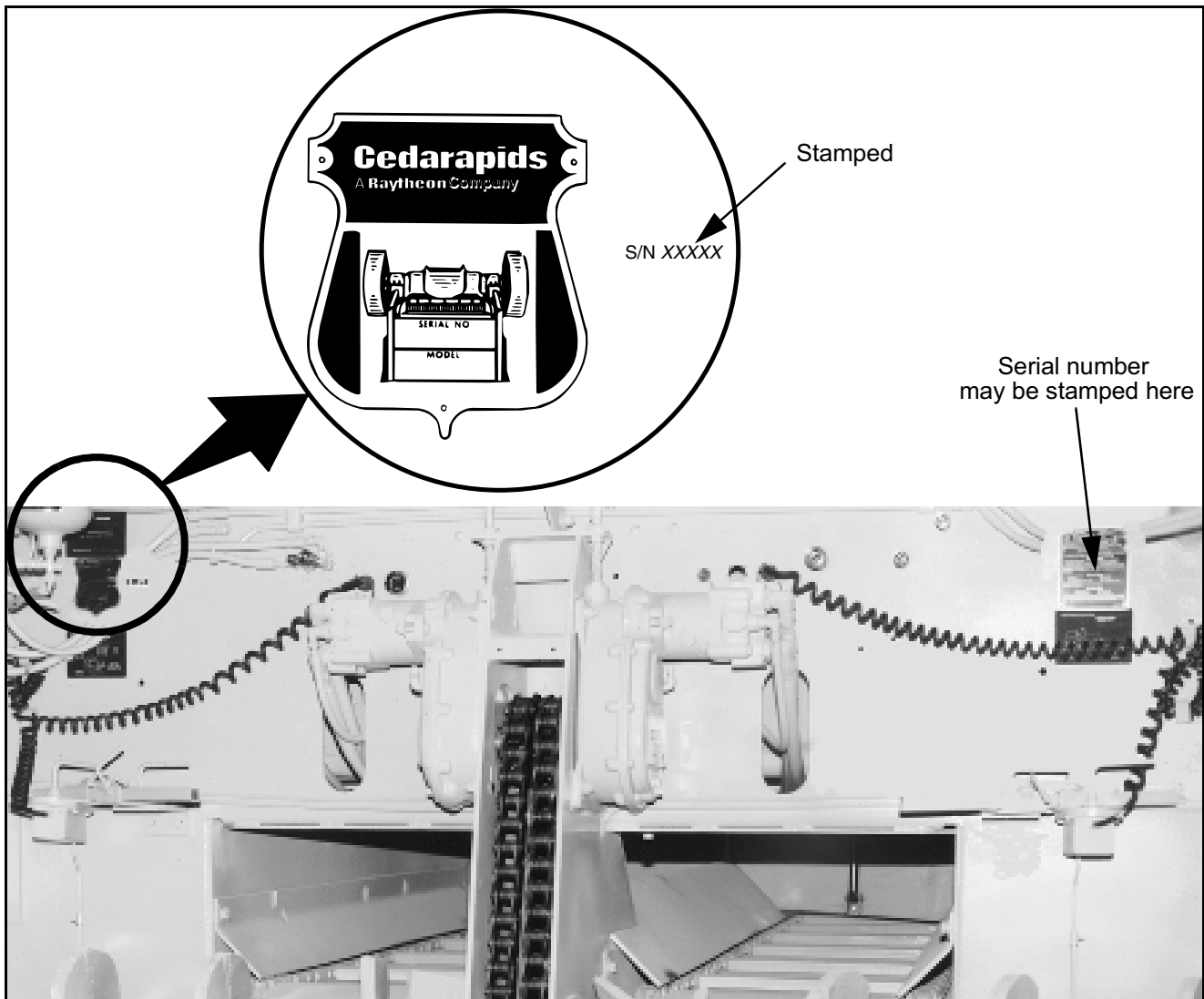

Figure 1 - 2 Tractor ID Number Locations

The serial number plate for current model tractors can be found on the left rear frame bulkhead. In addition, the serial number will be stamped into the bulkhead to the right of the serial number plate. On early model tractors, the serial number may be stamped into the bulkhead and covered with the serial number plate. (Figure 1 - 2)

The serial number will also appear on the lubrication decal found on the right rear frame bulkhead.

Identification Number Location

Screed

The various Fastach and Stretch screeds carry both a serial number and a module number to simplify identification when ordering parts.

The identification plate bearing both numbers is located on the right-hand screed pull arm on the current Fastach screeds. In addition, the screed module number is stamped on the right-hand pull arm below the identification plate. (Figure 1 - 5)

The plate is on the right-hand tipping frame on the current Stretch screeds. The module number is also stamped directly below the identification plate and on the right-hand main screed frame end plate. (Figure 1 - 6)

On early-model Fastach (Figure 1 - 3) and Stretch (Figure 1 - 4) screeds where the serial number was not included on the screed, the serial number of the tractor must be used when ordering parts for the screed or tractor.

If a Fastach screed is shipped as a single item (to be mounted on a paver in the field) the serial plate will be mounted below the screed identification plate on the right-hand pull arm.

On single-item Stretch screeds the serial plate will be adjacent to the screed identification plate on the right-hand tipping frame.

Refer to the following illustrations for locations of the stamped module numbers and identification.

Identification Number Location

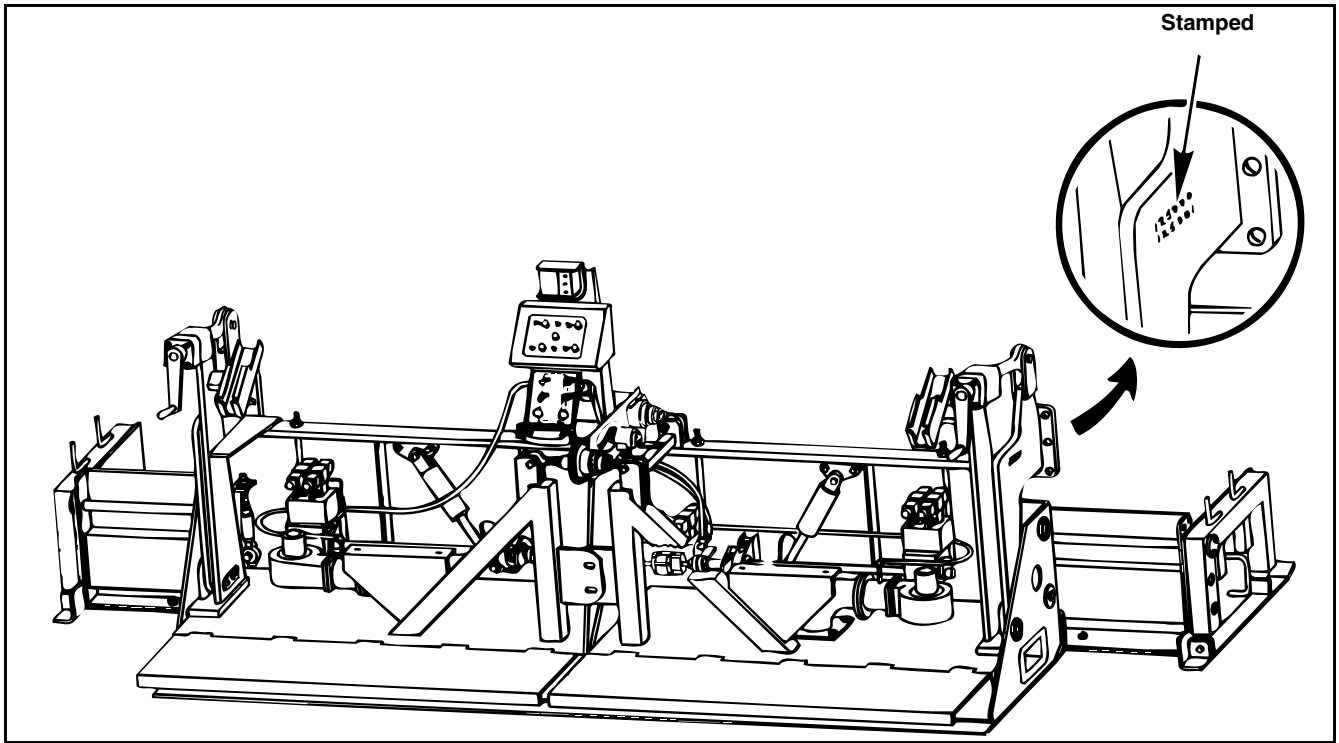

Figure 1 - 3 Early Fastach

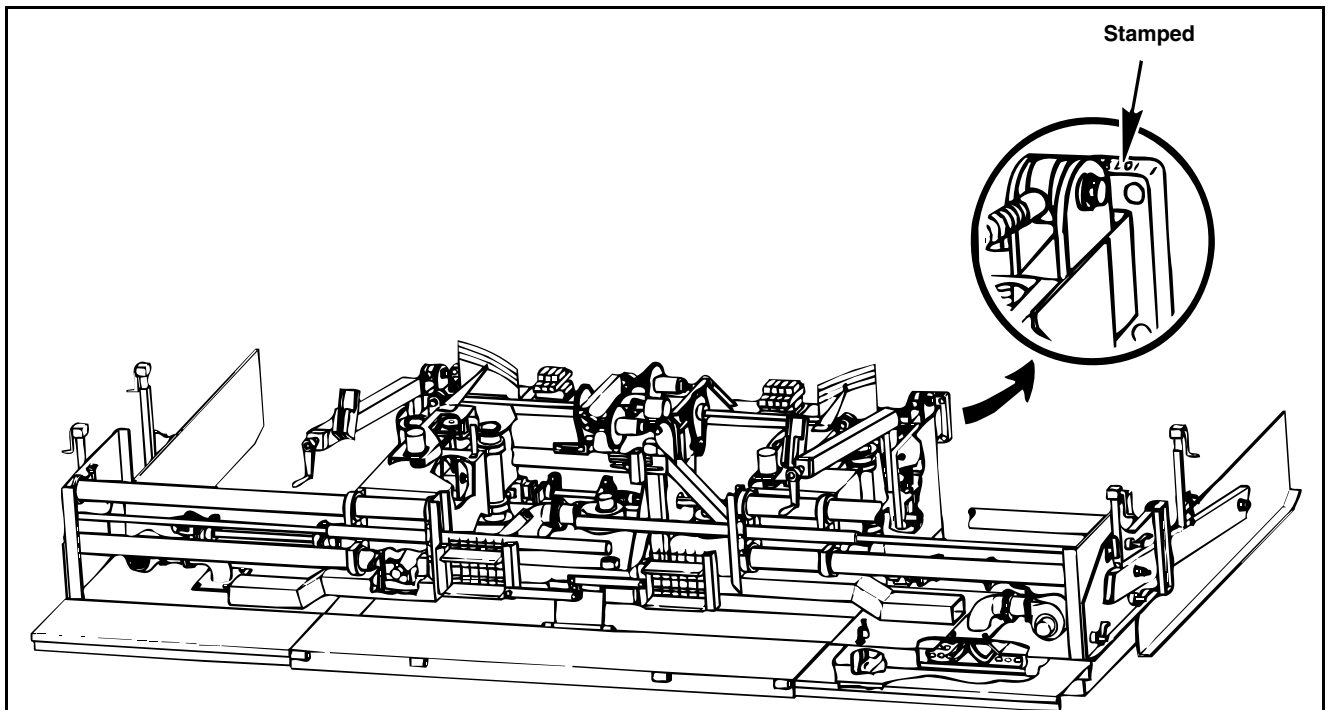

Figure 1 - 4 Early Stretch 20

Identification Number Location

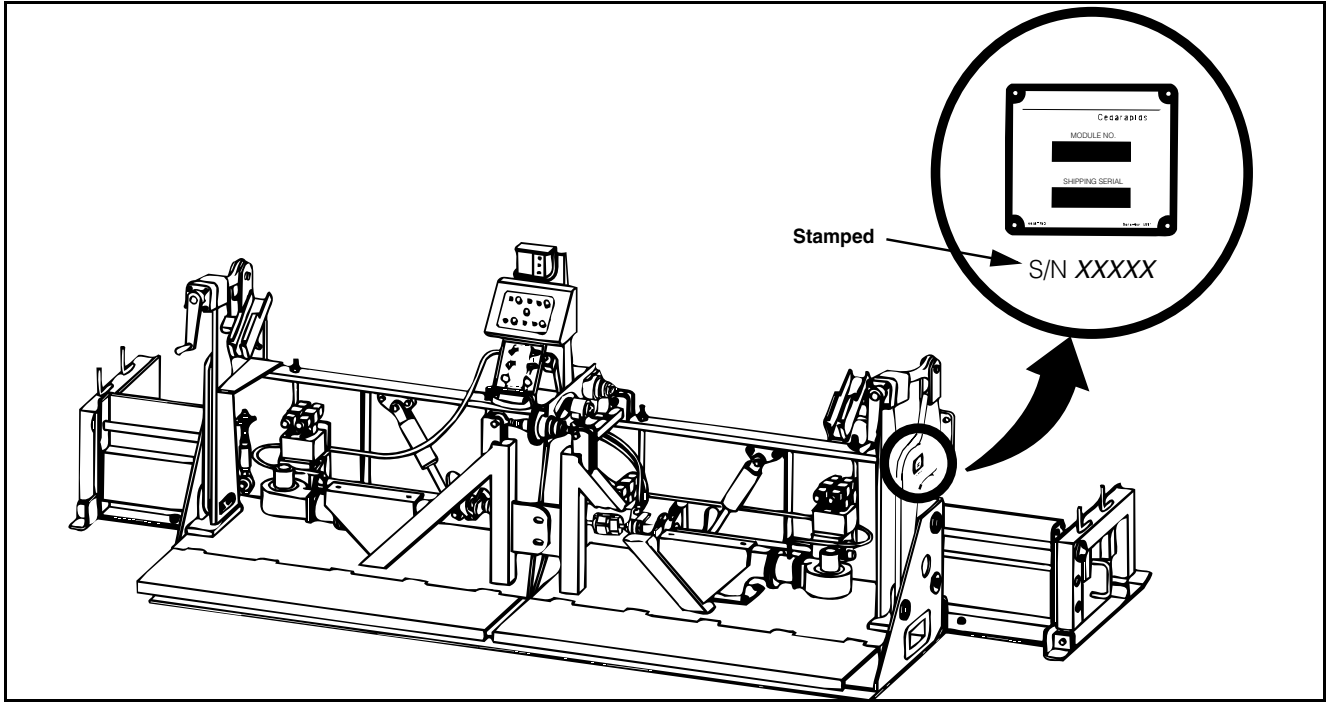

Figure 1 - 5 Current Fastach

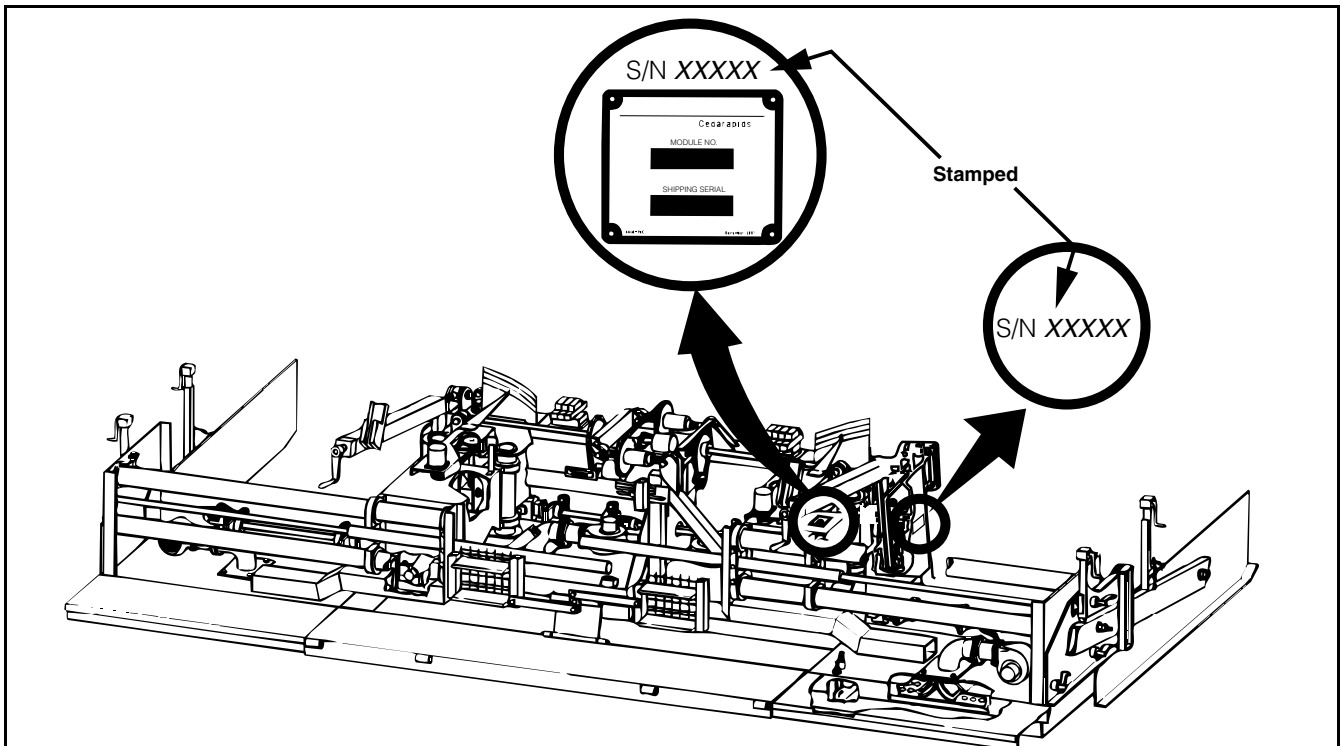

Figure 1 - 6 Current Stretch 16, 18, & 20

Lockout Tagout



Warning: Failure to follow good lockout and tagout procedures could result in serious injury or death.

What is the purpose of lockout /tagout?

- Prevent the unexpected or accidental start-up of equipment and to notify other workers when a piece of equipment is unsafe to operate.
- Prevent injury to personnel from energy that is stored in devices such as springs, accumulators, hydraulic systems, batteries, etc.

How do I lockout and tagout equipment?

- Turn the master key to the OFF position and remove the key.
- Disconnect the batteries.
- Regardless of which lockout method is used, place one or more tags on machine controls or access doors to let other workers know that maintenance is being performed on the machine and/or the machine is unsafe to operate.

Who is responsible for establishing and administering a lockout /tagout program?

- The employer must establish a lockout /tagout system of procedures, training and periodic inspection before any employee operates, services, or maintains a piece of equipment.
- All employees are responsible for seeing that equipment is locked out and tagged out according to the employers policies.

Lockout Tagout

When is lockout and tagout necessary?

- Any time repairs or maintenance on a machine are to be performed.
- When cleaning or lubricating the machine.
- While clearing blocked or jammed mechanisms.
- Any time that the equipment will be left unattended.

Who should apply a lock or tag?

- Any maintenance person who will be working on the equipment.
- The foreman or team leader responsible for the job.
- Anyone who will be working on the equipment.
- If several people will be working on a piece of equipment, each person must apply their own tag.

When can a lock or tag be removed?

- After all safety guards are back in place.
- After work is complete and tools are put away.
- After workers are positioned safely for start-up.
- After controls are positioned correctly for start-up and machine is operation ready.

Who can remove a lock or tag?

- Only the person who applied a lock or tag can remove it.

General safety

This manual contains important information regarding the operation of your paver. Carefully read the entire manual before attempting to operate the paver.

Danger

- Install all auger guards and vibrator covers before operating the paver.
- Never attempt to install or remove any part or assembly when the paver is running.
- Do not allow personnel to stand or walk between the front of the paver and the back of the truck while the paver is operating.
- Attach screed safety cables or lower the screed before performing any inspections, repairs or adjustments to the screed.
- All guards and protective devices must be in place when the paver is being operated or moved.
- Keep all personnel clear of augers when the paver is operating.
- Do not refuel the paver with the engine or screed heater system running. All sparks and open flames must be kept a minimum of 50 feet away from the paver when refueling.
- Do not wash or spray down the screed or tractor with the screed heater system operating.

Warning

- Do not operate this equipment until you have been trained in its operation or maintenance. This equipment may only be operated or maintained by trained personnel, who have demonstrated their ability to do so safely.

General safety

- Keep this manual for future reference.
- Read, understand and follow all current OSHA, federal, state and local regulations that are applicable to your job and equipment.
- This equipment must be used in accordance with all operation and maintenance instructions.
- All persons involved with this equipment must be familiar with this manual.
- Read, understand, and follow all Danger, Warning, Caution and instruction decals in this book and on the paver.
- When changing the paver configuration or adding equipment to the paver, all additional guards associated with the added equipment must be installed before operating or moving the paver.
- Any changes made to the original design of the paver must be approved by qualified personnel to ensure that the changes include appropriate guarding and provide a safe working environment for all personnel.
- Wear clothing that fits snug to prevent getting caught in moving parts. Loose-fitting clothing should never be worn.
- Mount and dismount the paver from the rear using only the steps, handrails and walkways provided.
- Do not mount the paver when it is moving.
- Allow only the operator on the operator's platform when the paver is in operation.
- Before starting the paver, make sure the brakes are ON, all other systems are OFF and all personnel are clear.

General safety

- Before leaving operator's seat, always place the brake switch ON, and all other controls or switches in OFF or NEUTRAL position.
- Reduce travel speed when going down step grades to prevent over-speeding.
- Do not allow personnel near the hopper area when the paver is running.

Caution

- Wear protective mask when harmful air pollution exists.
- Wear safety goggles, gloves and long-sleeve shirts when working near hot asphalt materials.
- Wear ear plugs while paver is running.
- Keep operator's platform, steps and screed walkways clear of all obstructions, tools and other items to prevent tripping or falling.
- To prevent fire hazards, keep the screed and engine basket area free of oil, asphalt and trash buildup.

Receiving New Equipment

Receiving New Equipment

Before accepting and unloading a new paver, the consignee must inspect the equipment for evidence of damage or missing parts. This inspection process should be thorough, because once the freight receipt is signed, it is assumed that all of the equipment listed on the receipt was received in good condition.

Make a thorough inventory of all loose components packaged in boxes. A check list is provided in each box listing the components in the box. While performing the inventory, inspect all loose components for damage which may have occurred during transit. Any damage that happens to the equipment in transit is the responsibility of the carrier **not** Cedarapids. Claims for damage must be submitted to the carrier for settlement.

When evidence of damage or loss is discovered, have the driver make a notation on both the carrier's and consignees' copies of the freight bill. Prior to signing the freight bill, take pictures of the damage and identify the truck if possible. The consignee can then sign the bill to acknowledge delivery. The consignee should then have the carrier's terminal manager or his authorized representative make an official inspection of the damage or loss.

Equipment should not be moved from the original receiving point until this official inspection has been made. Good clear photos will verify and explain damage in any claim action which may follow. When the inspection is done, the consignee should file a written damage claim with the carrier's office and should report this action to the area distributor for Cedarapids Inc.

If hidden damage is found after the carrier's representative has gone, do not continue to unpack or move the equipment. Contact the carrier's local

office and have the terminal manager or authorized representative make an immediate personal inspection of the damage. Obtain a written description of the damage, and photos if possible, signed by the representative as proof of a valid claim.

A packet of equipment warranty/start-up information will be sent to the distributor before the equipment leaves the factory. All warranty/start-up forms must be filled out and returned to Cedarapids within **24 hours** after the equipment is received.

Function and Application

Section 2 - Equipment Description

Function and Application

The paver will lay a uniform high density asphalt mat for highways, roadways, airport runways, parking lots and driveways. It is capable of performing jobs with strict control specifications and high production requirements.

The paver will level and compact mix up to 12" in depth, with mat widths varying from 6' to 30'. Mat depth and width variations are accomplished by adjusting feed controls and adjusting the screed.

Operating Principle

The hot mix is dumped by truck into the hopper or picked up by a windrow machine at a rate suitable for continuous paving. While dumping mix, the truck is pushed forward by the paver. (Figure 2 - 1)

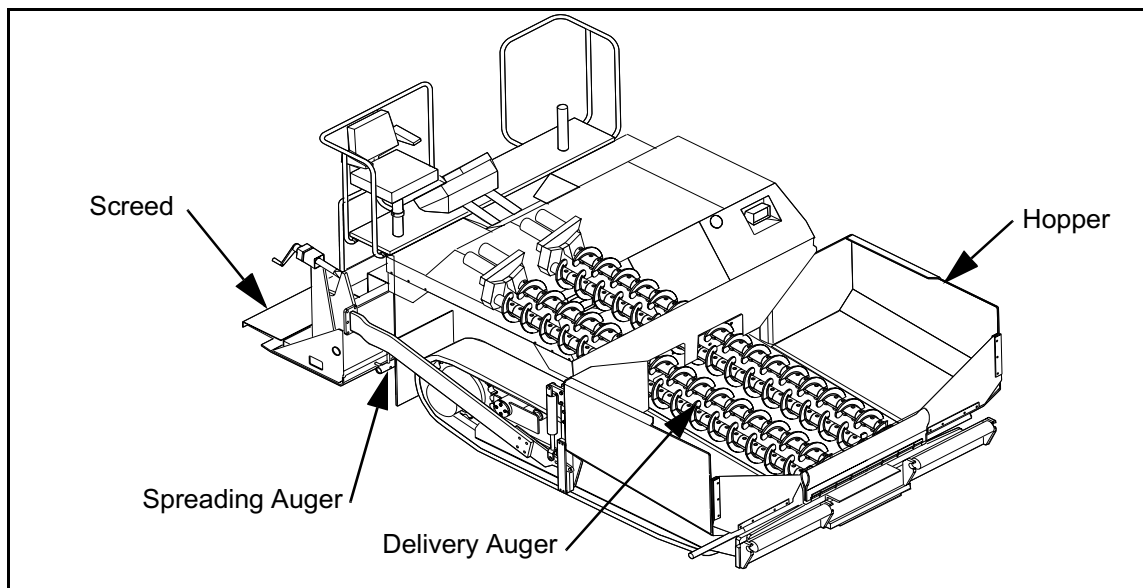

Figure 2 - 1 Asphalt Flow

Two sets of counter-rotating delivery augers remix the hot mix as it is conveyed to the spreading augers at the rear of the tractor. The speed of each set of delivery augers is controlled independently to maintain the proper level of material. The spreading augers distribute material along the entire width of the screed. Material feed may be either manually or automatically regulated to maintain an even and consistent "head of material" in front of the screed. A strike off plate mounted directly in front of the screed bottom meters the material passing under the screed bottom. The screed rides up or floats on the mix to level and

smooth the mat. Contour of the mat may be set to a desired slope with the adjustable screed controls. Screed controls are adjusted manually or automatically to create the desired mat.

The screed has vibrators which aid the initial "ironing" of the mat. Final compaction of the newly laid mat is accomplished by a roller.

The screed has burners that heat the screed bottom close to the temperature of the mix before paving begins. Heating the screed bottom prevents asphalt from sticking to the screed bottom which causes tearing and a poor mat surface.

Function and Application

The screed can be fitted with extensions or extendible strike-offs for paving wide widths or shoulders.

The fume recovery system is designed to collect fumes given off by hot mix asphalt and discharge them away from operator work areas. This system is standard equipment on all Grayhound pavers manufactured after July 1, 1997 (Figure 2 - 2). The system is designed to collect fumes given off by

asphalt mix as it is distributed along the length of the main screed by the spreading augers. The fumes are drawn into a hydraulically driven fan. The fan then blows the fumes into the engine exhaust muffler. Inside the muffler the asphalt fumes are combined with the engine exhaust and discharged through the exhaust pipe. A vacuum gauge indicates amount of vacuum generated in the fan intake manifold.

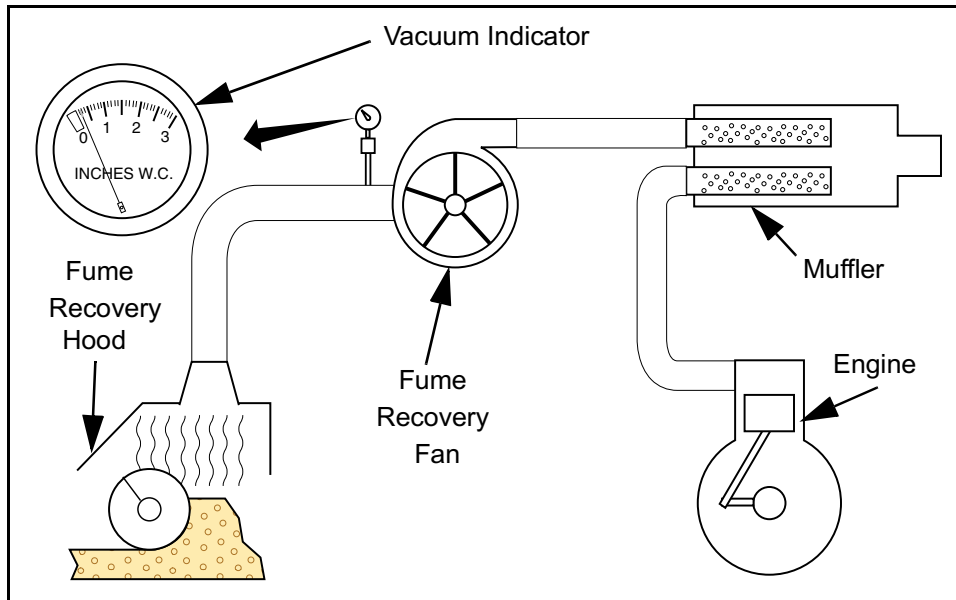

Figure 2 - 2 Fume Recovery System Overview

Optional Equipment

Screed Extension

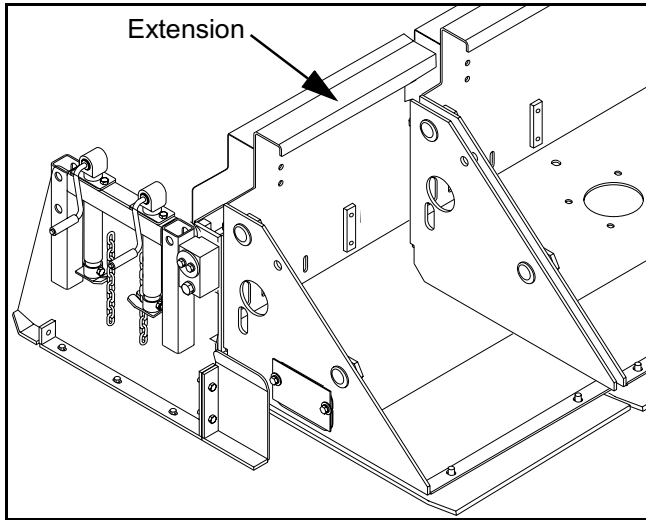

Figure 2 - 3 Screed Extension

Screed extensions are furnished in 6", 12", 24" and 36" lengths which make it possible to pave widths up to 30'. Both screed and auger extensions can be quickly attached. It is recommended that auger extensions be 1' less than the screed extensions used. For example; with a 1' screed extension no auger extension is needed, with a 2' screed extension use a 1' auger extension, etc. (Figure 2 - 3)

Optional Equipment

Slopeable Hydraulic Strike-off Extension

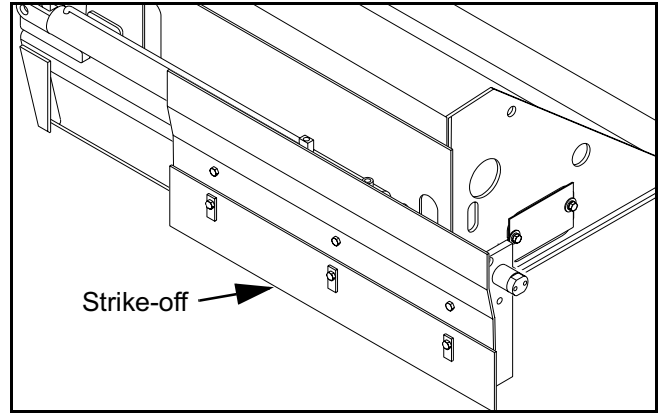

Figure 2 - 4 Slopeable Hydraulic Strike-off Extension

Hydraulic strike-off extensions are ideal for parking lots because they reduce or eliminate handwork to bleed out material at driveways, tapers, flush-to-wall work, etc. This reduces the need for extra passes which saves time and makes any paving operation more profitable.

These strike-offs provide a level surface and constant mat depth extendible up to 4' on each side. Strike-off blades are easily adjusted to match main screed strike-offs. Hydraulic slope adjustment simplifies laying drainage contours and other special applications. (Figure 2 - 4)

Truck Hook

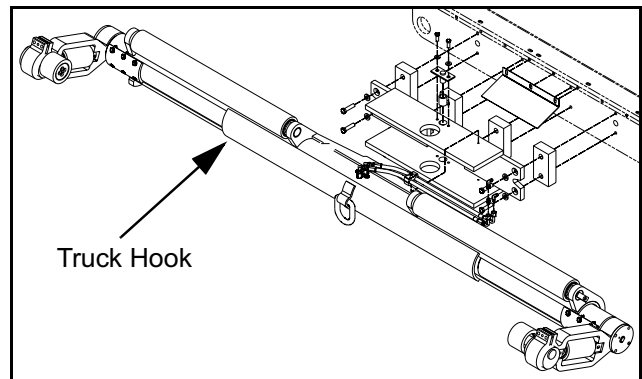

Figure 2 - 5 Truck Hook

Optional Equipment

The truck wheels ride against the push rollers which pushes the truck ahead of the paver. To prevent the truck from pulling away from the paver while moving down a hill, retractable rollers hook into the inside of the truck wheels. (Figure 2 - 5)

Bevel Guide Plate

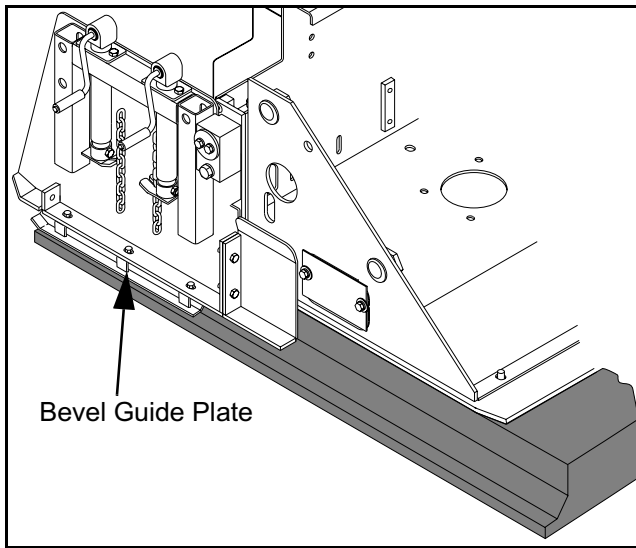

Figure 2 - 6 Bevel Guide Plate

The adjustable bevel plate bolts to screed end plate to assure a smooth sloping contour on the edge of the mat. Two plates are available: one for 1-1/2" depth and one for 3" depth with bevel angle at 45°. (Figure 2 - 6)

Automatic Grade and Slope Control

The grade and slope control enables the paving contractor to lay uniform and smooth mats automatically, regardless of irregularities in the roadway. It also provides precise slope angle for curves in roadway.

Topcon Grade and Slope Control

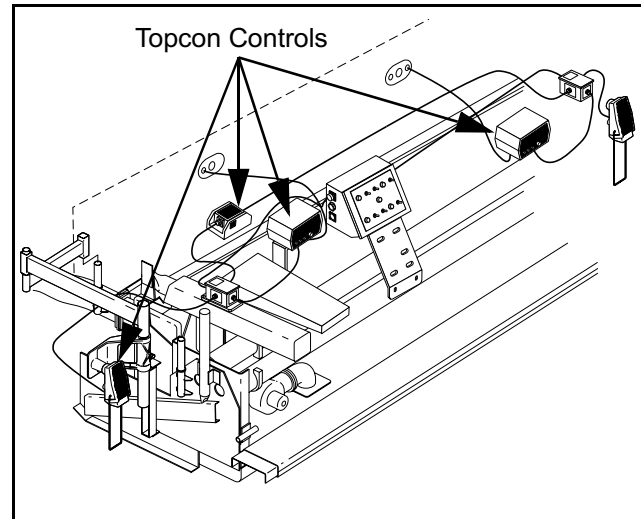

Figure 2 - 7 Topcon Grade and Slope Control

The Topcon grade and slope control system includes sonic grade sensors and a pendulum slope sensor to maintain the desired mat profile. (Figure 2 - 7)

Night Lighting Kit

This kit includes four high pressure sodium lamps and a separate generator to light up the work area at night. (Figure 2 - 8)

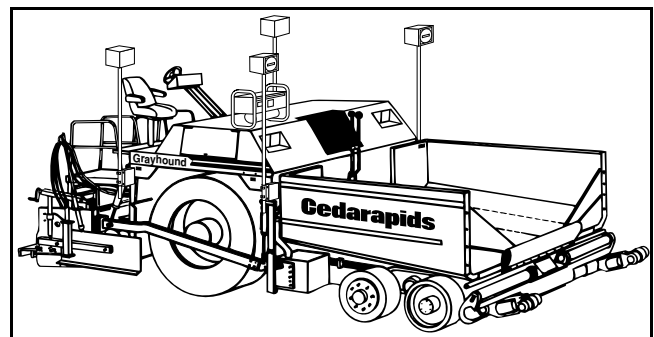

Figure 2 - 8 Night Lighting Kit

Optional Equipment

Grade Reference Ski

Two grade reference ski systems are available; the multi-foot ski and tube ski. The skis are available in 20', 30', and 40' lengths. Skis travel along an existing road surface sensing changes in grade while averaging out bumps. The tube ski consists of a single tube section which rides directly on the road surface. The multi-foot ski consists of a main beam supported by several skid plates. Each skid plate is spring mounted to provide independent movement over irregular surfaces. As the ski passes over bumps each skid plate is deflected independently while the main beam maintains a constant level. This allows the screed to produce a mat with minimal bumps. (Figure 2 - 9)

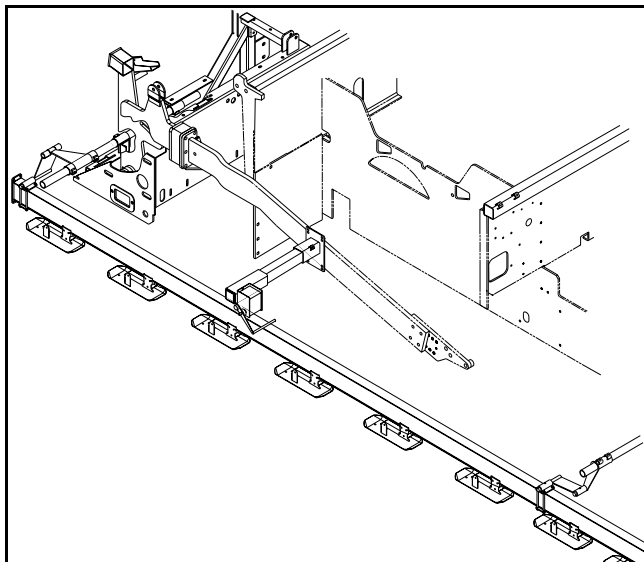

Figure 2 - 9 Multi-Foot Ski

The over-the-screed ski uses the multi-foot or tube ski in front of the screed to sense changing grade and a skid plate that rides behind the screed on the new mat surface. This system produces the smoothest mat surface by “averaging” the grade of the existing road surface and the newly laid mat. (Figure 2 - 10)

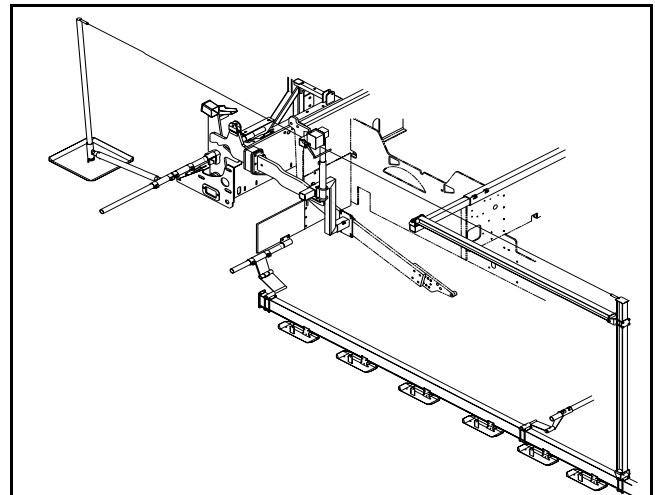

Figure 2 - 10 Over-the-Screed Ski

Material Retaining Plates

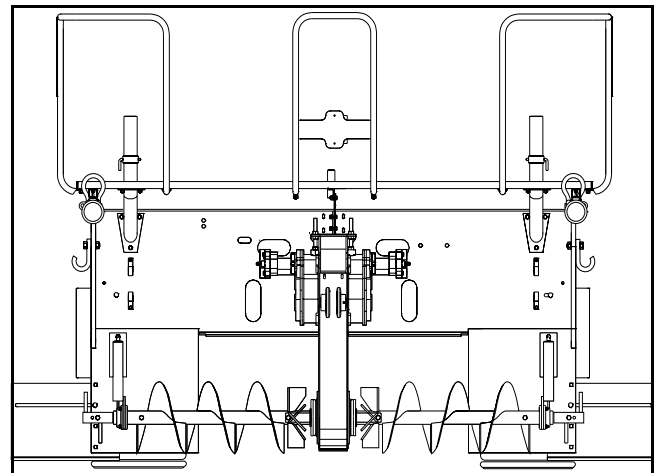

Figure 2 - 11 Material Retaining Plates

Material Retaining Plates are mounted to the paver frame and extend out toward the end gate during wide width paving. They limit the amount of material that builds up in front of the auger. When extensions up to 4' are added to one end of a screed, a retaining plate support brace is attached to the screed pull arm. When more than 4' of extensions are used an extra support brace is added. (Figure 2 - 11)

Optional Equipment

Auger Extensions

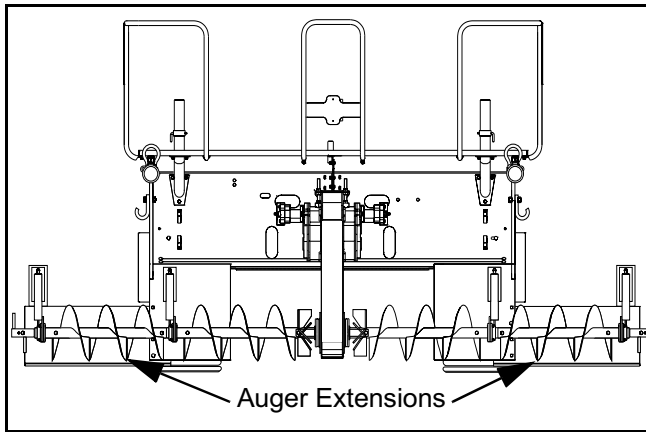

Figure 2 - 12 Auger Extensions

As extensions are added to the screed or when a screed or strike-off is extended, auger extensions must be added to move material out the full width of the screed. Auger extensions are available in 1', 3', and 5' lengths. (Figure 2 - 12)

End Gates

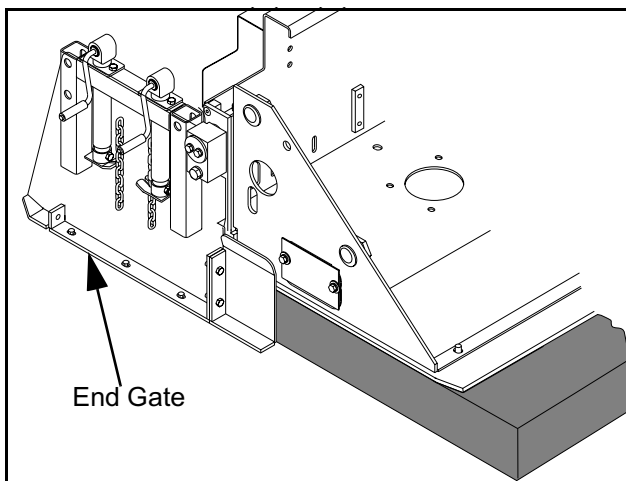

Figure 2 - 13 End Gates

End Gates are mounted on the end of the screed, extension, or extendible strike-off. They prevent material from spilling out beyond the reach of the screed and form a good edge on the mat. (Figure 2 - 13)

Cutoff Shoe

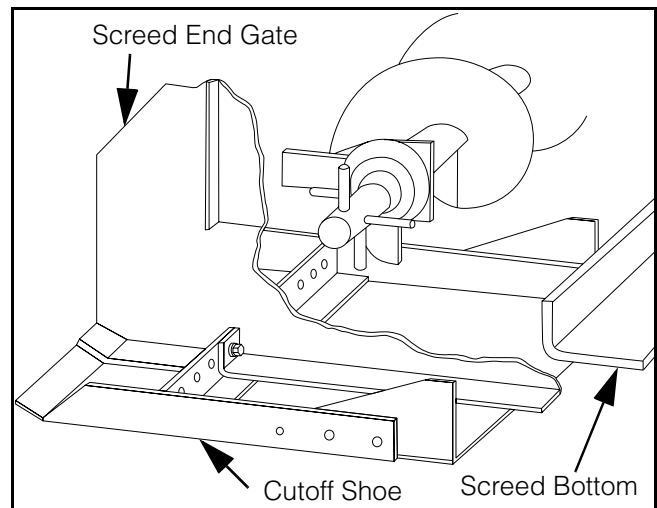

Figure 2 - 14 Cutoff Shoe

Standard cutoff shoes attach to the screed end gate when paving at less than the full width of the screed. The shoe can be adjusted in 1-1/2" increments. (Figure 2 - 14)

Optional Equipment

Front Wheel Assist

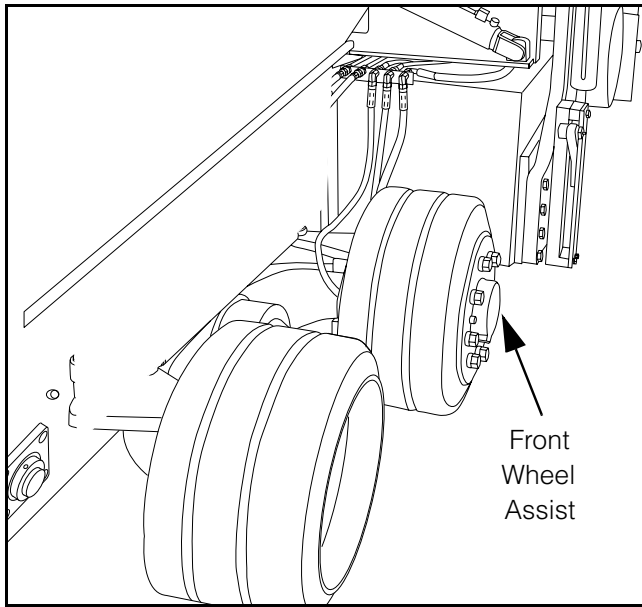

Figure 2 - 15 Front Wheel Assist

Gives paver up to 50% more tractive effort with the flip of a switch on the operator's control panel on the 451 Paver. (Figure 2 - 15)

Proportional Material Feed control

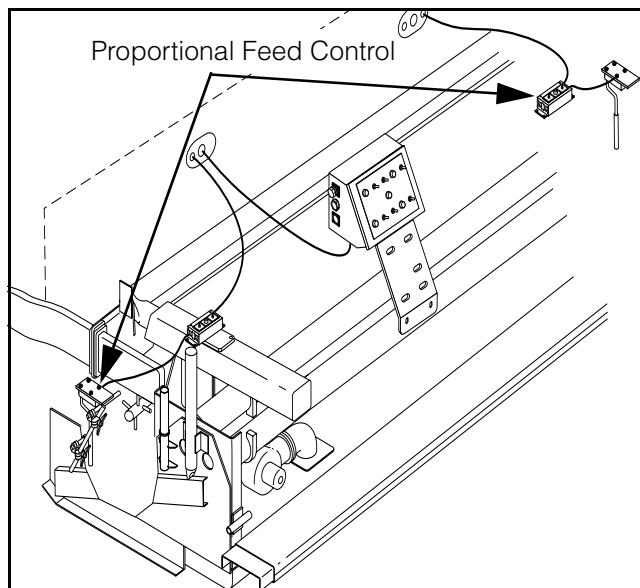

Figure 2 - 16 Proportional Feed Control

A mechanical wand measures the height of the material and adjusts auger speed as needed to maintain a uniform head of material in front of the screed. (Figure 2 - 16)

Sonic Feed control

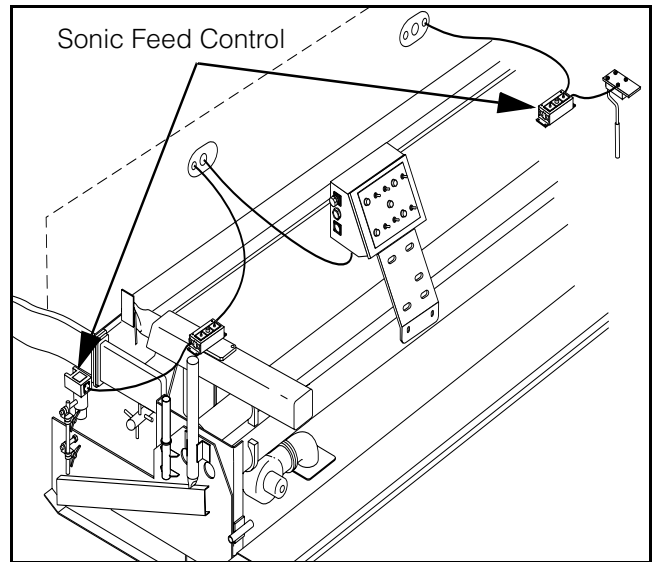

Figure 2 - 17 Sonic Feed Control

Adding a Sonic control further automates material feed to the auger. Weather-resistant sensor unit uses sound pulses to measure material height at the auger. Material delivery is regulated to maintain a uniform material head. (Figure 2 - 17)

Operator's Console

Operator's Console

The operator's console can be positioned so that the paver can be operated from the left or right seat. To reposition the operator's console:

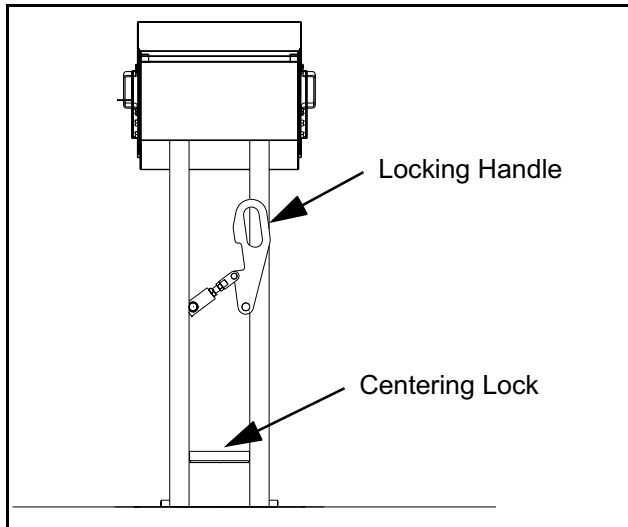

Figure 2 - 18 Repositioning operator's console

- 1) Lift the locking handle to release the console. (Figure 2 - 18)
- 2) Pull the operator's console toward the center of the paver. When the console is positioned vertically the centering lock will automatically engage.

Important - When raising the hood, the operator's console must be locked in the center position to prevent the hood from hitting console.

- 3) Step on the centering lock to release the console and position the console to the desired side of the paver.

Refer to (Figure 2 - 19) and (Figure 2 - 20) for instructions on operating the CR451 console and (Figure 2 - 21) and (Figure 2 - 22) for instructions on operating the CR461 console.

Operator's Console

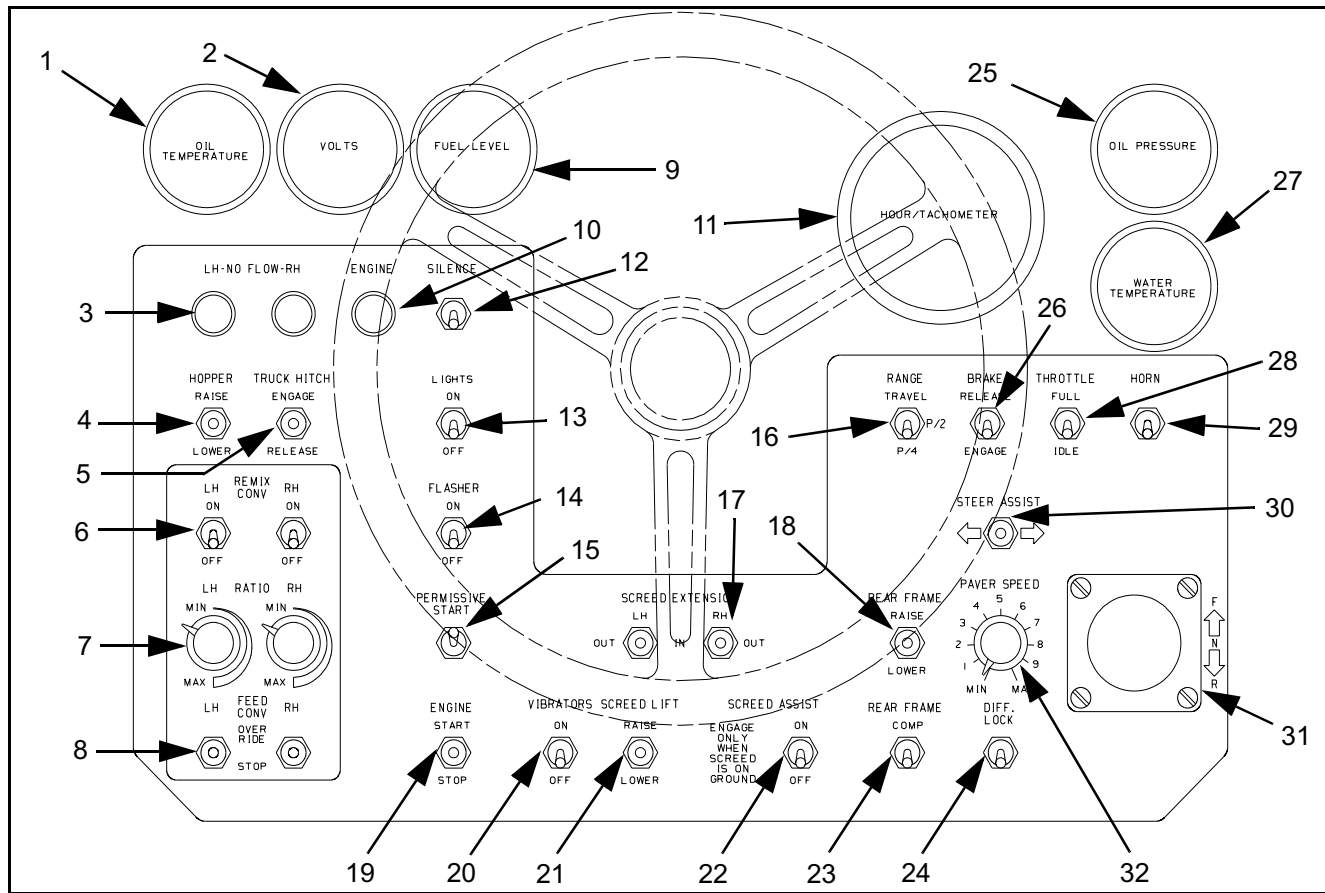

Figure 2 - 19 CR451 Driver's Console - Units Prior to Sept. 1999

- | | | |
|-----------------------------|----------------------------|--------------------------|
| 1) Oil Temperature Gauge | 13) Lights | 25) Oil Pressure Gauge |
| 2) Voltmeter | 14) Flashers | 26) Brake |
| 3) Non-Functional | 15) Permissive Start | 27) Engine Coolant Temp. |
| 4) Hopper | 16) Travel Speed Range | 28) Throttle |
| 5) Truck Hitch | 17) Screed Extensions | 29) Horn |
| 6) Remix Delivery Augers | 18) Frame Raise | 30) Steer Assist |
| 7) Delivery Auger Speed | 19) Engine Start Switch | 31) Travel Lever |
| 8) Auger Override | 20) Vibrators | 32) Paver Speed Dial |
| 9) Fuel Level Gauge | 21) Screed Lift | |
| 10) Low Engine Oil Pressure | 22) Screed Assist | |
| 11) Hour/Tachometer | 23) Rear Frame Compensator | |
| 12) Non-Functional | 24) Differential Lock | |

Operator's Console

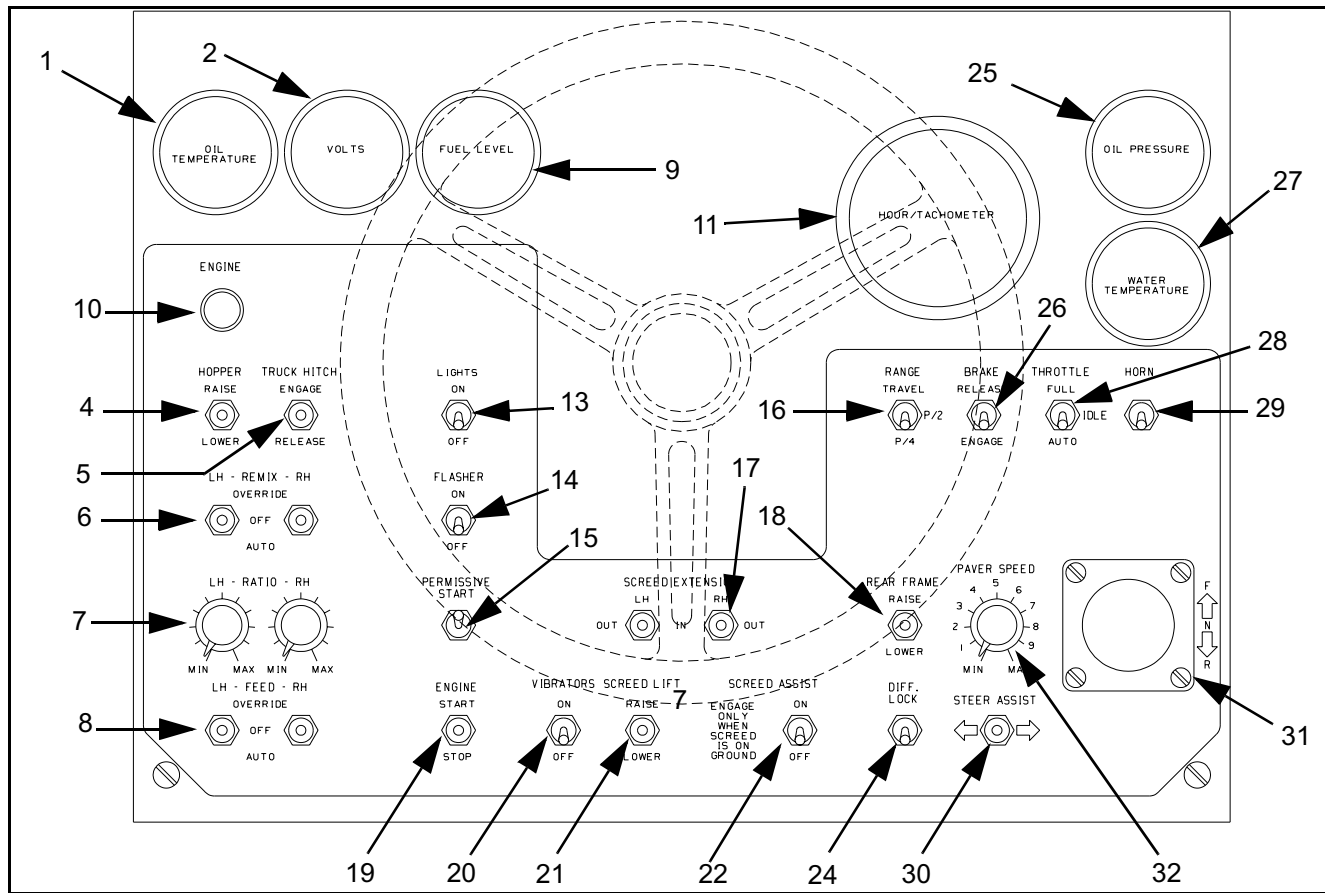

Figure 2 - 20 CR451 Driver's Console - Units After Sept. 1999

- | | | |
|-----------------------------|-------------------------|--------------------------|
| 1) Oil Temperature Gauge | 13) Lights | 25) Oil Pressure Gauge |
| 2) Voltmeter | 14) Flashers | 26) Brake |
| 3) N/A | 15) Permissive Start | 27) Engine Coolant Temp. |
| 4) Hopper | 16) Travel Speed Range | 28) Throttle |
| 5) Truck Hitch | 17) Screed Extensions | 29) Horn |
| 6) Remix Delivery Augers | 18) Frame Raise | 30) Steer Assist |
| 7) Delivery Auger Speed | 19) Engine Start Switch | 31) Travel Lever |
| 8) Auger Override | 20) Vibrators | 32) Paver Speed Dial |
| 9) Fuel Level Gauge | 21) Screed Lift | |
| 10) Low Engine Oil Pressure | 22) Screed Assist | |
| 11) Hour/Tachometer | 23) N/A | |
| 12) N/A | 24) Differential Lock | |

Operator's Console

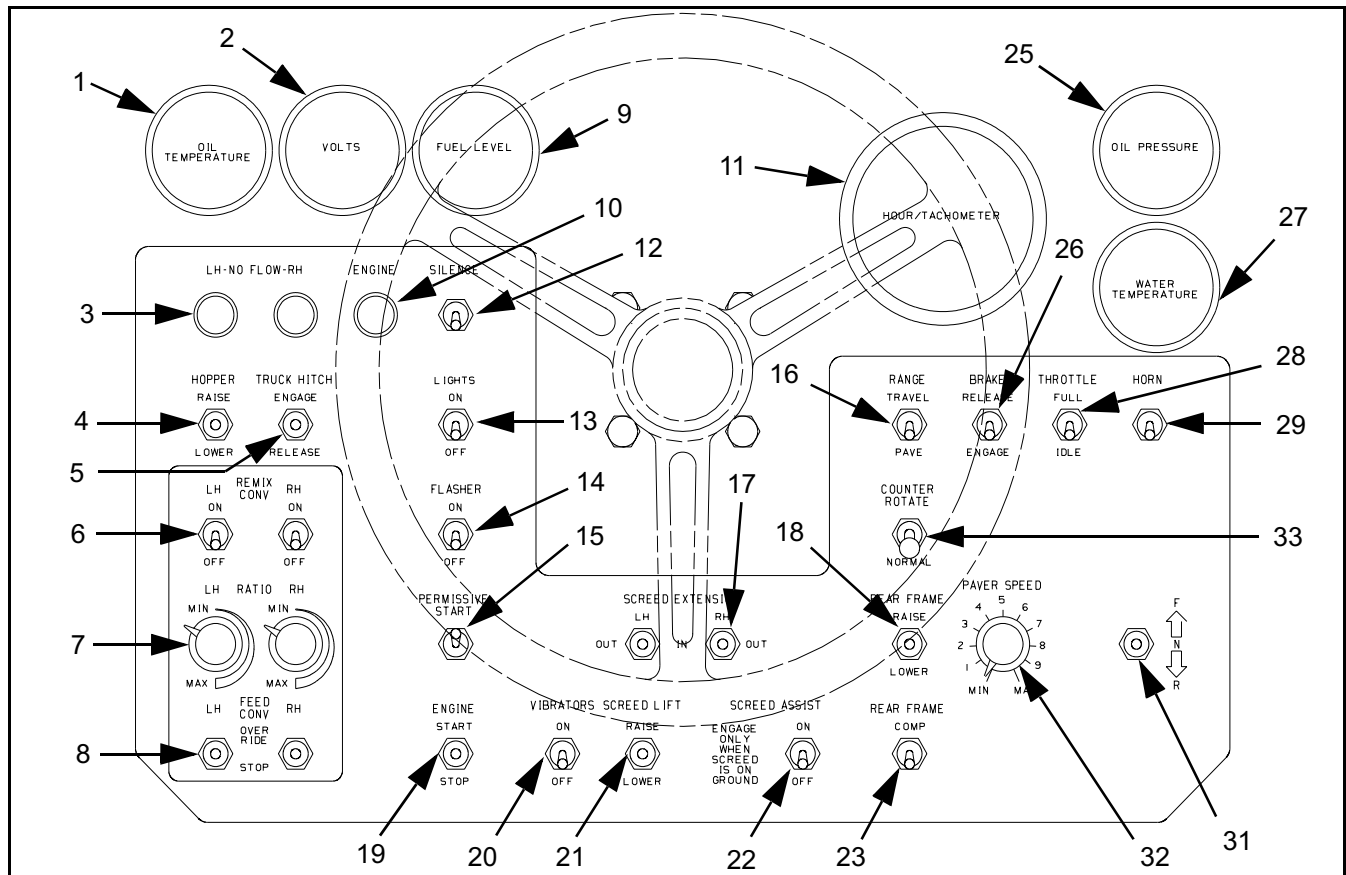

Figure 2 - 21 CR461 Driver's Console - Units Prior to Sept. 1999

- | | | |
|-----------------------------|----------------------------|---------------------------|
| 1) Oil Temperature Gauge | 13) Lights | 25) Oil Pressure Gauge |
| 2) Voltmeter | 14) Flashers | 26) Brake |
| 3) Non-Functional | 15) Permissive Start | 27) Engine Coolant Temp. |
| 4) Hopper | 16) Travel Speed Range | 28) Throttle |
| 5) Truck Hitch | 17) Screed Extensions | 29) Horn |
| 6) Remix Delivery Augers | 18) Frame Raise | 30) CR451 Only |
| 7) Delivery Auger Speed | 19) Engine Start Switch | 31) Travel Switch |
| 8) Auger Override | 20) Vibrators | 32) Paver Speed Dial |
| 9) Fuel Level Gauge | 21) Screed Lift | 33) Counter Rotate Switch |
| 10) Low Engine Oil Pressure | 22) Screed Assist | |
| 11) Hour/Tachometer | 23) Rear Frame Compensator | |
| 12) Non-Functional | 24) CR451 Only | |

Operator's Console

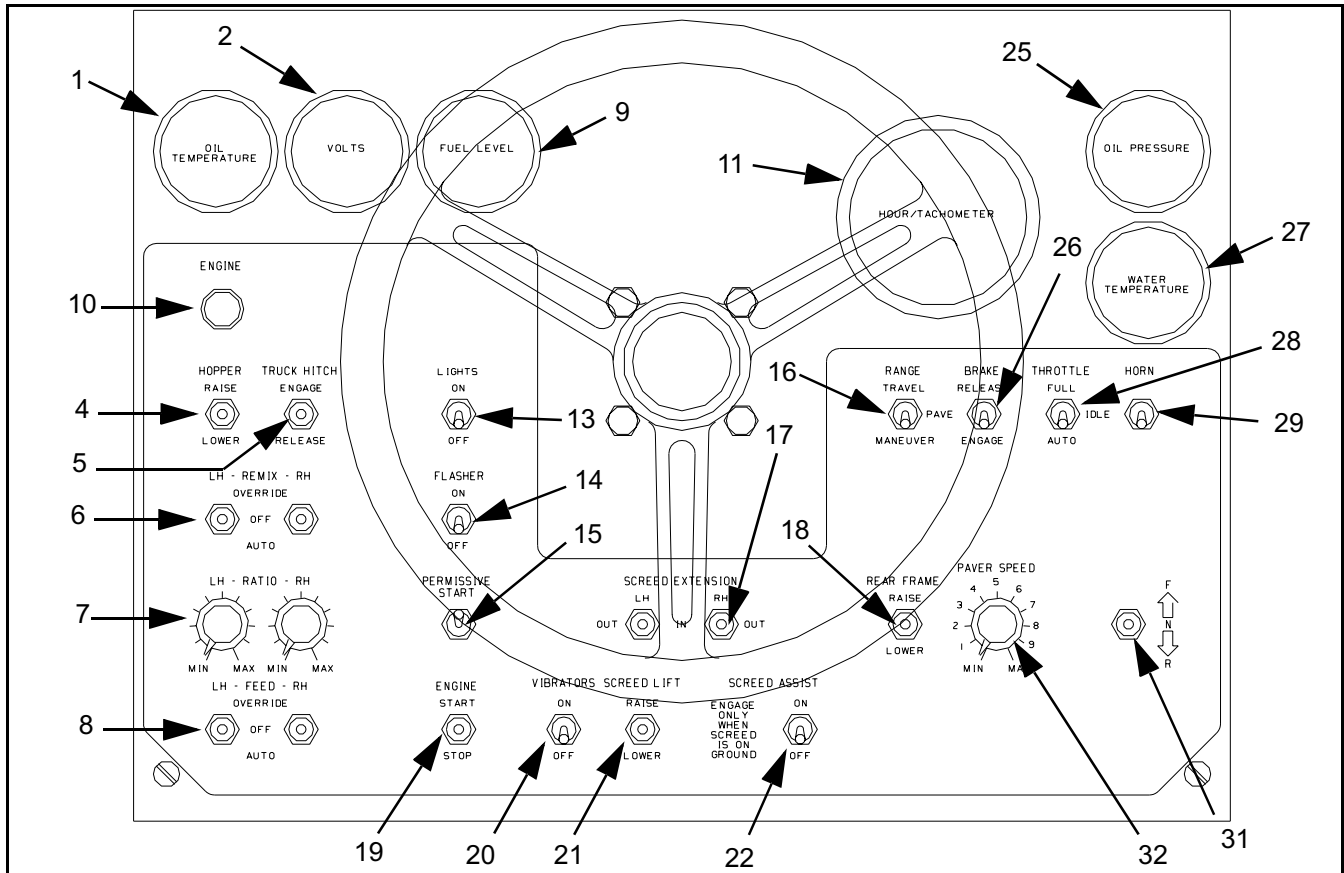

Figure 2 - 22 CR461 Driver's Console - Units After Sept. 1999

- | | | |
|-----------------------------|-------------------------|--------------------------|
| 1) Oil Temperature Gauge | 13) Lights | 25) Oil Pressure Gauge |
| 2) Voltmeter | 14) Flashers | 26) Brake |
| 3) N/A | 15) Permissive Start | 27) Engine Coolant Temp. |
| 4) Hopper | 16) Travel Speed Range | 28) Throttle |
| 5) Truck Hitch | 17) Screed Extensions | 29) Horn |
| 6) Remix Delivery Augers | 18) Frame Raise | 30) CR451 Only |
| 7) Delivery Auger Speed | 19) Engine Start Switch | 31) Travel Switch |
| 8) Auger Override | 20) Vibrators | 32) Paver Speed Dial |
| 9) Fuel Level Gauge | 21) Screed Lift | 33) N/A |
| 10) Low Engine Oil Pressure | 22) Screed Assist | |
| 11) Hour/Tachometer | 23) N/A | |
| 12) N/A | 24) CR451 Only | |



Operator's Console

- 1) **Oil Temperature Gauge** - Indicates temperature of hydraulic fluid. If fluid temperature exceeds 180° F stop paving and determine cause.
- 2) **Voltmeter** - Indicates battery and alternator condition. (Table 2 - 1)

Reading on Voltmeter	Engine not running or running at idle	Engine running at Full throttle
less than 10 V 10 V to 12 V	Dead or disconnected battery Low battery charge. Constant reading in this area may indicate problems with the charging system.	Dead or disconnected battery A voltmeter reading below 12 volts means that the current being drawn for lights, charging the battery, solenoids, etc. exceeds the output of the alternator. Check for a defective battery or a short in the wiring.
12 V to 13 V 13 V to 15 V	Well charged battery in good condition. Readings in this area while the engine is not running indicate defective voltmeter.	When the engine is started the pointer may stay in this area temporarily but should gradually rise above 13 volts as alternator reaches normal output. This is where the readings should be when the alternator and battery are in good condition and functioning properly.
Above 15 V	Readings in this area while the engine is not running indicate defective voltmeter.	When the pointer goes above 15 volts, the alternator is putting out too much voltage and should be checked. Continued operation of the engine in this range will damage the battery and solenoid valves.

Table 2 - 1 Voltmeter indications

- 3) **Mix Flow Indicators** - Units prior to Sept. 1999 only, these are non-functional. Later units did not have these indicators. then let the switch return to neutral to hydraulically lock the truck. To unhitch, place the switch in the “Release” position.
 - 4) **Hopper** - The hopper raise switch is spring-loaded to automatically return to the neutral position when released. It must be held in the “Raise” or “Lower” position to control the hopper wings. The truck hook is equipped with an adjustable needle valve on the front bulkhead which controls the speed that the truck hook engages the trucks wheels. Rotate the needle valve clockwise to reduce the engage speed and counterclockwise to engage the truck hook quicker.
 - 5) **Truck Hook** - The optional truck hitch holds the truck in position at the front of the paver so little or no material is spilled after a truck is captured. The truck driver does not have to ride the brakes to stay firm against the paver. When in “MANUAL” or “AUTO” position, delivery auger speed is controlled by the Delivery Auger Speed control (item 7). When in “OFF” position, delivery augers stop.
- The Truck Hook switch is spring-loaded to return to the neutral position when the switch is released. To engage the truck, hold the switch in “Engage” until the truck is in place,

7) **Delivery Auger Speed** - Adjusts the speed of the delivery augers relative to the speed of the spreading augers.

8) **Auger Override** - This is a 3-position switch. If this switch is set to “Stop”, the spreading and augers stop.

If this switch is set to the center (unmarked) position, the spreading augers are allowed to run. Auger speed is regulated by the proportional feed system.

When this switch is in the “Override” position, the spreading augers run at full speed unless the screed feed switch is in “STOP” position.

9) **Fuel Level Gauge**

10) **Low Engine Oil Pressure Indicator** - This indicator will light when the engine oil pressure falls below 5 PSI. When the engine is first started and the permissive start switch is held on, this indicator will remain lit until the engine oil pressure rises above 5 PSI. Once this indicator goes out the permissive start switch can be released.

11) **Hour / Tachometer** - Indicates engine RPM’s and operating hours. Full throttle engine speed = 2100 RPM, Idle speed = 950 RPM.

12) **Audible Alarm Silence** - Units prior to Sept. 1999 only, this is non-functional. Later units do not have this function.

13) **Lights** - Push up to turn headlights on “High”, down for “Low”, or center for “Off”. Work lights are turned on when the switch is in “High” or “Low” setting. A rotary switch on each work light changes light from red, white, and off.

Operator’s Console

14) **Flasher** - Push up to turn flashers “On”, down to turn flashers “Off”. On 400 series pavers this switch also turns on the strobe warning light mounted in the rear center of the paver.

15) **Permissive Start Switch** - When starting the engine, this switch must be held down until the engine starts and the engine oil pressure rises over 5 PSI and the Engine indicator goes out. If this switch is release before the engine oil pressure reaches 5PSI, the engine will stop.

16) **Range** - The range switch on CR461s prior to Sept. 1999 has two positions; “Travel” and “Pave”. The switch on units after Sept. 1999 has three positions; “Travel”, “Pave”, & “Maneuver”.

The CR451 has a three-position switch. Select the “Travel” position for roading or travelling around the job site. Select the “P/2” position for paving in 2-wheel drive. The paver must be stopped before changing from “Travel” to “Pave” or “Pave” to “Travel”



Warning: Failure to stop the paver before changing from “Travel” to “Pave” or “Pave” to “Travel” could result in serious injury to anyone riding the paver.

If the paver is equipped with the optional front wheel assist, switching to the “P/4” position will drive two of the front wheels in addition to the rear wheels. If the paver is not equipped with the optional front wheel assist, switching to the “P/4” position will be the same as switching to the “P/2” position. Engaging the optional front wheel assist will reduce the paver speed by 30%. Stop the paver before switching from “P/2” to “P/4” or from “P/4” to “P/2”.

17) **Screed Extensions** - Used on Stretch model screeds to extend or retract the extensions. On Fastach screeds this switch is used to extend or retract the optional hydraulic sloping strike-off extension.

18) **Frame Raise** - Push up to “Raise” the rear of the paver, down to lower the rear of the paver.

This switch allows the operator to elevate the rear of the tractor to give maximum ground clearance for loading the paver or traveling over rough ground or obstacles. For additional traction during paving, set the clearance at about the halfway point.

When using a heavy screed with extensions or other heavy accessories, it may be necessary to lower the screed to the ground before raising the Frame Raise system.

19) **Engine** - The engine will start only if the brakes are engaged, the travel lever/switch is in neutral, permissive start switch is engaged, and the Master Key is “On”.

20) **Vibrators** - The vibrator switch will function only when the travel lever/switch is forward. Push up to turn vibrators “On”, down to turn vibrators “Off”.

21) **Screed Lift** - Push up to “Raise” the screed, down to “Lower” the screed, or center for “Neutral”. After the screed is raised to the desired height and the switch is released, it returns to the hold position. The screed is hydraulically locked at that height. While paving, the switch must be set in the “Lower” float position.

Operator's Console

22) **Screed Assist** - Pavers equipped with power extending screeds (Fastach II, Stretch 16, Stretch 18, Stretch 20) have a Screed Assist system that allows adjustment of the screed bearing pressure on the mat. Once turned on, the screed assist should be left on. Do not switch the screed assist on and off while the paver is in motion. The screed assist should only be turned on when the screed is resting on the ground and should be turned off prior to raising the screed.

Notice: If the screed is raised when the screed assist switch is in the ON position the screed could drop suddenly, seriously damaging the screed.

23) **Rear Frame Compensator** - Units prior to Sept. 1999 only. This feature can be turned on to increase paver traction due to small changes in the road surface. The compensator should only be used when traction slippage occurs.

24) **Differential Lock** - CR451 only. In wet or slick conditions one wheel may lose traction and begin to spin. By activating the optional differential lock switch, both rear wheels will rotate at the same speed regardless of how much traction each wheel has.

25) **Engine Oil Pressure Gauge** - Indicates engine oil pressure. Minimum oil pressure = 5 psi. Engine will shut down if engine oil pressure falls below 5 psi and the permissive start switch is not engaged.

26) **Brake** - The brake switch engages and releases the brakes. Brakes will not release until sufficient system pressure is built up and the switch is set to the “Release” position. Do not use for routine braking. Use only for parking and emergency stops.



- 27) **Engine Coolant Temperature Gauge** - Indicates engine coolant temperature. Normal operating temperature = 205° F. Engine will shut down if engine coolant temperature exceeds 223° F.
- 28) **Throttle** - The engine has only two speeds. Use “Idle” to start and warm up the engine, hydraulic oil, and screed. Use “Full” position for all other functions. Switch to “Full” only after engine and hydraulic oil have warmed up.
- 29) **Horn** - Push up to sound the horn. When the switch is released, it will return to the “Off” position.
- 30) **Steer Assist** - CR451 only. The steer assist switch is spring loaded to return to center. When the switch is activated to one side or the other, the system slows the inside rear drive motor while continuing to drive the other motor at regular speed. This has the effect of abruptly steering the paver in the direction the switch is pushed.
- 31) **Travel Lever/switch** - Moving the travel lever/switch forward or back moves the paver in the desired direction. Speed is increased as the lever is moved to full forward or reverse - (CR451 & CR461 w/o steering wheel). This provides a smooth start and eliminates sudden shocks to the hydraulic system.

Operator's Console

- 32) **Max Paver Speed** - This dial is used to govern the maximum travel speed of the paver. The travel lever provides variable speed up to the setting on the speed dial.

Maximum speed for the wheeled paver is about 150 feet/minute paving speed (46 meters/minute) and about 12 miles/hour travel speed (20 km/hour).

The steel & rubber track pavers have a maximum paving speed in excess of 150 feet/minute and a maximum travel speed of about 5 miles/hour (9 km/hour) for steel track. The rubber track paver maximum travel speed is about 10 miles/hour (16 km/hour). A setting of five will be about half maximum speed.

With the Max Paver Speed dial at zero and travel lever/switch forward, the paver should not move. This is used to test the auxiliary systems.

- 33) **Counter Rotate Switch** - CR461 units prior to Sept. 1999 only. When this switch is in the counter rotate position, one of the tracks will move in the forward direction and the other will move in the reverse direction. This feature allows the paver to turn at zero turn radius. This switch does not function while the Travel Speed Range switch is in the “Travel” position.

Section 3 - Periodic Maintenance

Raising the hood

The hood on the Grayhound Paver must be raised to gain access to the engine for daily maintenance. The hood is raised using a hydraulic cylinder which is activated by a lever just under the hood on the right side of the machine in front of the rear wheel or drive sprocket. (Figure 3 - 1)

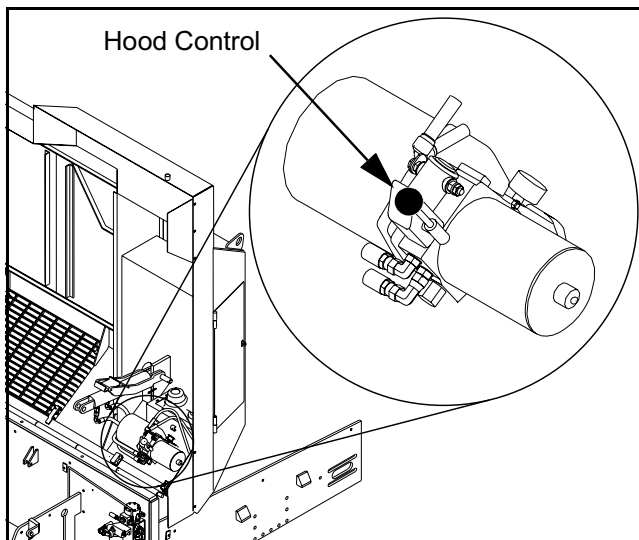

Figure 3 - 1 Hood Control

To raise the hood:

- 1) Position and lock the operator's console in the center position.
- 2) Turn on the master key switch before activating the hood control. Once the hood raising cylinder is fully extended, the hood safety lever will engage automatically.



Warning: Keep all personnel out from under the hood until the hood safety latch is engaged. Failure to follow these instructions could result in death or serious injury.

Raising the hood

- 3) Verify that the hood safety latch is engaged.

If the paver's batteries become discharged, jumper cables must be attached to the solenoid next to the hood raising lever and to the paver frame. (Figure 3 - 2) This will allow the hood raising lever to function in the normal manner.

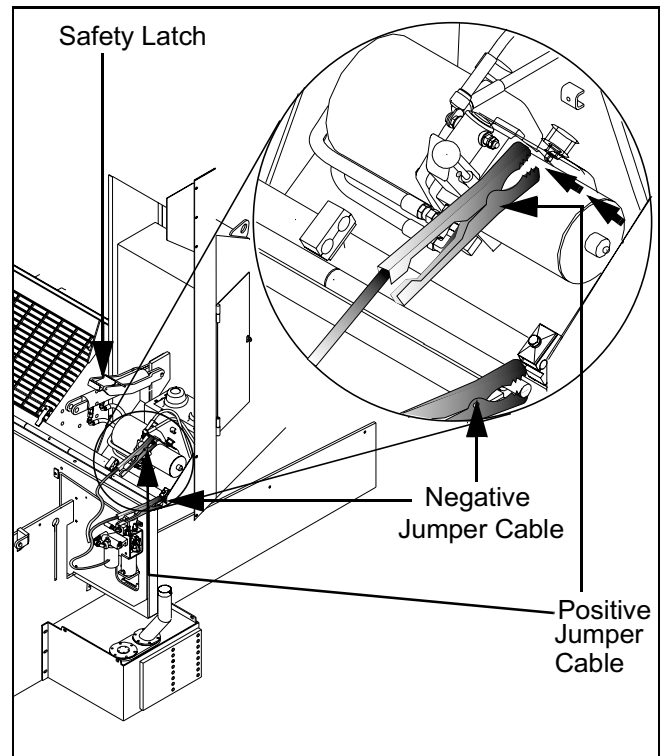

Figure 3 - 2 Connecting Jumper Cables



Warning: Keep all personnel out from under the hood until the hood safety latch is engaged. Failure to follow these instructions could result in death or serious injury.

To lower the hood, release the hood safety latch and activate the hood raising lever. (Figure 3 - 2)

Before Starting Engine

Before Starting Engine

Before starting the engine, the operator should check the following details personally.

- Verify that all decals are properly adhered to the machine, undamaged, and legible.
- Be sure all safety items (decals, guards, walkways, fire extinguisher, etc.) are in place and properly installed.
- Engine Oil Level should be at the “Full” mark on the dip stick. If engine oil is low, add oil to bring the level up to the “Full” mark. Refer to the engine manual for the correct oil type.
- Coolant Level inside the radiator should be just above the baffle. If not add the correct mixture of antifreeze and water. Do not over fill as excesses will be blown out the over flow. Refer to the engine manual to find the correct antifreeze and water mixture to use for the temperatures found in your working area.
- Hydraulic Oil Level must be checked while the hydraulic oil is cold and the machine is sitting level. If the hydraulic oil level is low, add the correct amounts of make up oil to bring the level to the COLD level on the sight glass.

Notice: Over filling the hydraulic tank does not leave enough room in the hydraulic system for thermal expansion when the oil is at running temperature. Excess oil will be blown out the breathers which could cause external radiator clogging.

Notice: Do not mix different types of oil. This could lead to unexpected failures.

- Engine Fuel Tank Level should be checked to ensure you have enough fuel to operate the paver for the desired amount of time.

Perform a visual inspection of the complete paver including engine compartment, for any signs of damage or leaks. Do not start the paver until all damage and leaks are repaired.



Maintenance Checklist

Maintenance Checklist

Ref.	Item to be checked	8 hrs	40 hrs	250 hrs	500 hrs	1000 hrs	Yearly	As Needed
1	Fuel level	I						F
2	Fuel Filter / Water Separator	D			R			
3	Travel Lever Alignment		I					A
4	Hydraulic Fluid	I/F			R*	R		
5	Oil Cooler	I						C
6	Suction Strainers				C			
7	Charge Filters		I		R			
8	Auxiliary Pump Filter				R			
9	Hydraulic lines and components	I						
10	Air Restriction Indicator	I						
11	Air Filter							C/R
12	Engine Oil	I/F		R				
13	Engine Oil Filter			R				
14	Engine Coolant	I/F					R	
15	Fan Belt		I					A
16	Radiator	I						C
17	Engine Cooling Fan	I						
18	Battery		I/F					
19	Tire Pressure		I/F					
20	Frame Raise Eccentric				L			
21	Steel Track Tension		I					A
21A	Rubber Track Tension		I					
22	Track Pivot		L					
23	Fire Extinguisher			I				
24	Horn	I						
25	Pump Drive Belts		I					A
26	Depth Cranks			L				
27	Vibrator Bearings	L						
28	Crown Control			L				
29	Match Height Assembly		L					
30	Extension Slope Assembly		L					
31	Final Drive Oil		I/F*			R		

Key: I - Inspect C - Clean R - Replace A - Adjust
 D - Drain L - Lubricate F - Fill * - Initial change only

Table 3 - 1 Maintenance checklist



Maintenance Checklist

Ref.	Item to be checked	8 hrs	40 hrs	250 hrs	500 hrs	1000 hrs	Yearly	As Needed
32	Steering Bogie Alignment							I/A
33	Steering Linkage			L			I/A	
34	Bogie Beam Bearings			L				
35	Front Wheel Bearings						L	
36	Bogie Wheel Toe In						I/A	
37	Delivery Auger Clearance		I					A (Every 120 hrs.)
38	Delivery Auger Drive - Gear Drive		I/F*			R		
39	Front Delivery Auger Bearings	L						
40	Spreading Auger Bearings	L						
41	Spreading Auger Drive Chains		I/					A
42	Spreading Auger Speed Reducer		I/F*			R		
43	Hood Raise Reservoir			I				
44	Operator Console Pivot Bearings			L				
45	Tow Arm Nose Roller	L						
46	Slope Beam Rod Ends			L				
47	Truck Hitch	C/L						
48	Fume Recovery System	I					I	C

Key: I - Inspect C - Clean R - Replace A - Adjust
 D - Drain L - Lubricate F - Fill * - Initial change only

Table 3 - 1 Maintenance checklist (Continued)

Periodic Maintenance

Periodic Maintenance

1) Fuel Level



Warning: Keep away from sparks or open flame while working with fuel.

Check fuel level before each work period to ensure you have enough fuel to operate for the desired period of time. Refer to the engine manufacturers manual to determine what grade of fuel to use for your operating temperature and conditions.

2) Fuel/Water Separator



Warning: Keep away from sparks or open flame while working with fuel.

Daily Maintenance

Drain the water and sediment from the separator daily. (Figure 3 - 3)

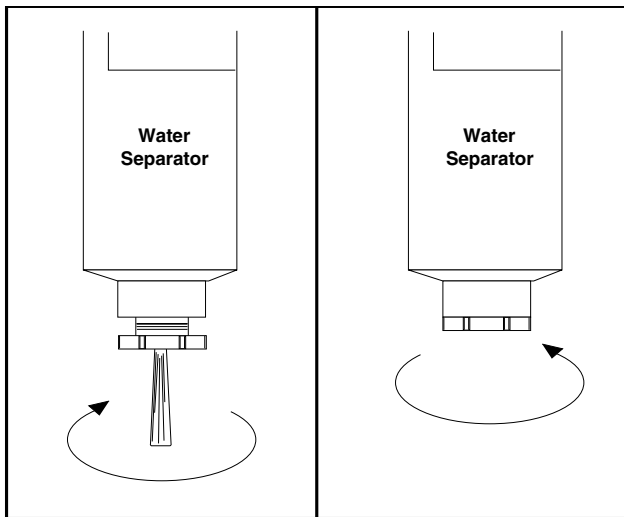

Figure 3 - 3 Draining fuel/water separator

Shut off the engine. Use your hand to open the drain valve. Turn the valve counterclockwise approximately 1-1/2 to 2 turns until liquid starts draining slowly. Drain the filter sump of water until clean fuel is visible.

Turn the valve clockwise to close the drain.

Notice: Do not over tighten the valve. Over tightening can damage the threads.

Filter Replacement

Replace the fuel filter/water separator every 500 hour of operation. Some operating conditions may require replacement at shorter intervals for proper engine operation.

To replace the fuel filters:

- 1) Clean the area around the filter head.
- 2) Remove the filters.
- 3) Clean the gasket surface of the filter head.
- 4) Replace the O-ring.
- 5) Fill new filters with clean fuel and lubricate the O-ring seal with clean lubricating oil.
- 6) Install filters and tighten.

Notice: Overtightening may distort the treads or damage the filter element.

Periodic Maintenance

3) Travel Lever Alignment

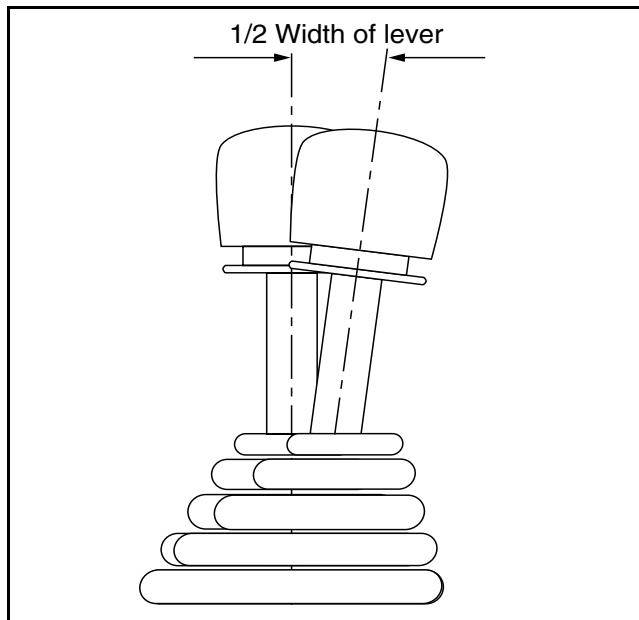

Figure 3 - 4 Travel lever alignment

CR451 and older CR461 Grayhound pavers use a travel lever to control travel speed and direction. During normal operation of older CR461 pavers, when the paver is travelling in a straight line over a flat, level surface, both travel levers should be advanced an equal amount. The travel levers need to be brought back into alignment when one travel lever is advanced more than 1/2 of the width of a travel lever more than the other lever. (Figure 3 - 4) Refer to the Technical manual for travel lever adjustment procedures.

When travelling on a grade, on uneven terrain, or when connected to a truck or pickup machine, one travel lever may need to be advanced considerably farther than the other to maintain straight travel. Also, as the speed dial setting is varied, the travel lever position may need to be adjusted to keep the paver traveling in a straight line. In each of these cases the travel levers will need to be adjusted only if one of the travel levers is advanced to the stop before straight travel is achieved. If travel levers

are consistently out of alignment in one direction or the other the travel levers should be adjusted to bring them back into alignment.

4) Hydraulic Fluid

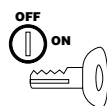

Warning: Turn off engine & remove key before performing any inspections or maintenance.

Hydraulic oil level must be checked while the hydraulic oil is cold and the machine is sitting level. If the hydraulic oil level is low, add the correct amounts of make up oil to bring the level to the COLD level on the sight glass.

Notice: Over filling the hydraulic tank does not leave enough room in the hydraulic system for thermal expansion when the oil is at running temperature. Excess oil will be blown out the breathers which could cause external radiator clogging.

Notice: Do not mix different types of oil. This could lead to unexpected failures.

The hydraulic fluid should be drained and replaced with new fluid every 1000 hours of operation. The hydraulic fluid in a new paver or a paver that has just had a new hydraulic pump or motor installed should be replaced after the first 500 hours of operation.

Cedarapids recommends use of a premium anti-wear, ISO Grade 68 hydraulic oil in all Grayhound Pavers. Grayhound Pavers ship from the factory with Texaco Rando HD 68 hydraulic oil. Other approved hydraulic oils in this class are: Amoco AW68; Exxon NUTO H68; Mobil DTE26; Shell Tellus 68; Chevron AW 68.

5) Oil Cooler

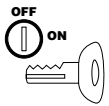

Warning: Turn off engine & remove key before performing any inspections or maintenance.

The oil cooler should be checked daily for dirt and other buildup that would restrict the air flow. The paving conditions will determine how often the oil cooler requires cleaning. If severe conditions exist or there are a lot of air-borne contaminants the oil cooler will require more attention. Any fluid leaking from any engine compartment component, hose or tube will find its way into the oil cooler.

If your paver is equipped with the oil cooler mounted in front of the radiator, check between the radiator and oil cooler for buildup. It is recommended that the oil cooler be separated from the radiator to thoroughly clean the radiator and oil cooler.

If your paver is equipped with a remote oil cooler, remove any dirt or debris that will restrict air flow through the oil cooler. Spray water from a garden hose from the bottom side of the oil cooler to the top to remove any dirt or grit that may have settled between the oil cooler fins.

Check for damaged hoses and loose or damaged hose clamps. Replace as required. Check the oil cooler for leaks and the core for damaged or bent fins. Clean and repair as required.

6) Suction Strainers

The suction strainers should be removed and cleaned every 500 hours of operation. To clean the suction strainers:

- 1) Clean the cover and suction manifold to prevent dirt from falling into the hydraulic reservoir.

Periodic Maintenance

- 2) Remove the cover from the suction manifold to gain access to the strainer. (Figure 3 - 5)
 - 3) Remove the strainer from the suction manifold. Be careful not to knock contaminants off the outside of the strainer as it is removed from the manifold.
 - 4) Clean the strainer with compressed air. Solvent can be used if needed.
 - 5) Install the strainer in the suction manifold.
 - 6) Check the condition of the O-ring seal. If the seal is damaged, install a new seal.
- Notice:** Severe pump damage will occur if the strainer cover is not sealed properly. Air will be drawn into the system causing pump cavitation.
- 7) Install the cover.
 - 8) Pressurize reservoir to 10 psi air pressure and check suction lines for leaks. Loosen fittings while under pressure to purge lines.

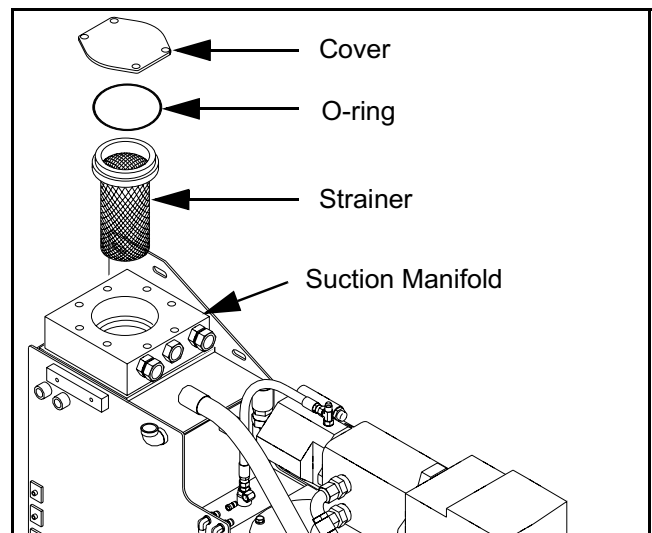

Figure 3 - 5 Suction Strainer

Periodic Maintenance

7) Charge Filters

The Grayhound remix paver has two charge filters that protect the traction hydraulic circuits, two charge filters that protect the delivery auger hydraulic circuit and two charge filters that protect the spreading auger hydraulic circuits. Each charge filter is equipped with an indicator that operates in the green zone when the filter is in good condition and operates in the red zone when the filter is dirty. The indicators should be checked every 40 hours with the engine at full throttle. Do not wait for the indicator to move into the red zone before replacing the filters. The filters should be replaced every 500 hours or when the indicator is operating in the red zone, which ever comes first. (Figure 3 - 6)

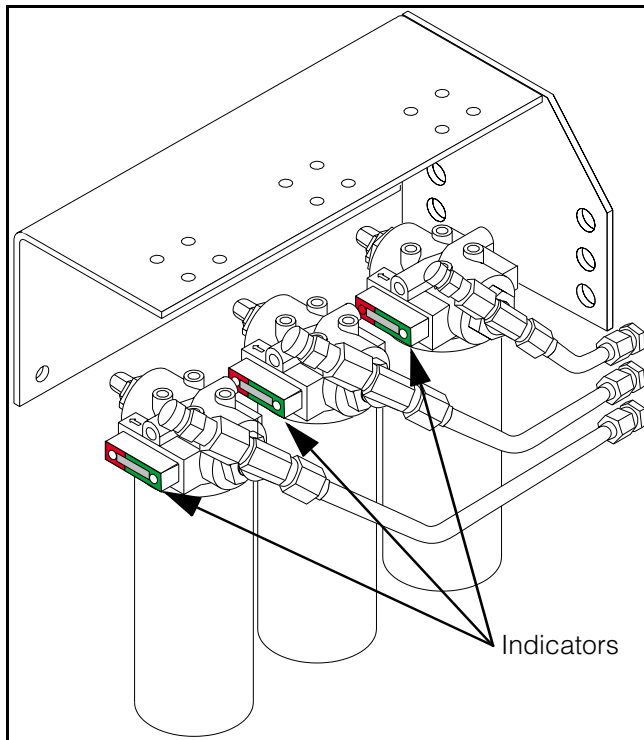

Figure 3 - 6 Charge Oil Filters

8) Auxiliary Pump Filter

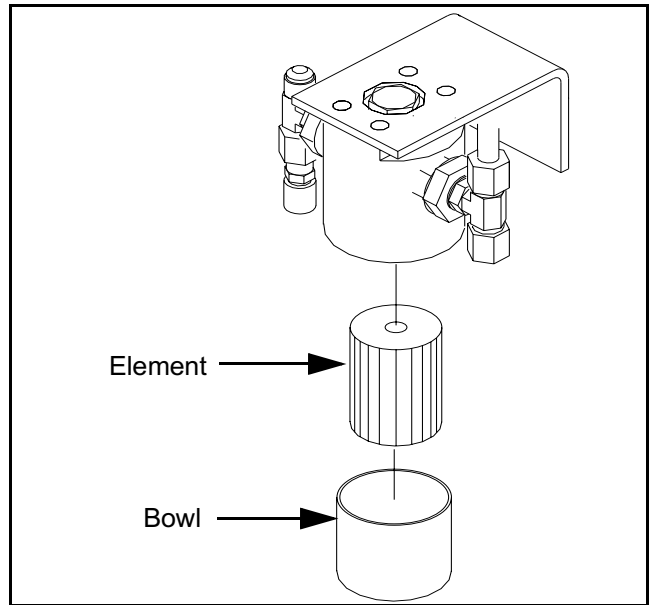

Figure 3 - 7 Auxiliary filter

There is one high pressure auxiliary filter located on the left side of paver on the front bulkhead. This filter consists of filter cap, filter element, and screw-in bowl. To change filter, remove bowl, replace element and reinstall bowl. (Figure 3 - 7)

9) Hydraulic lines and components

Check all hoses, tubes, and components for leaks, damage, or loose fittings. Check the ground for signs of fluid leakage. Spots of oil soaked dust may indicate a slow leaking hydraulic component. These leaks should be identified and fixed before operating the equipment.

10) Air Restriction Indicator

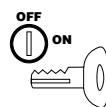

Warning: Turn off engine & remove key before performing any inspections or maintenance.

The engine air cleaner is equipped with an indicator that trips red when it needs service. The indicator should be checked daily to ensure proper servicing. (Figure 3 - 8)

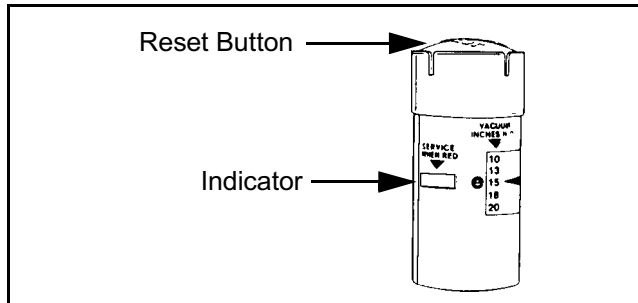

Figure 3 - 8 Air Restriction Indicator

Service the filter element when the red indicator flag is visible in the window.

After the air cleaner has been serviced, push the button to reset the service indicator.

11) Air Filter

Notice: Never operate a paver without an air cleaner. Intake air must be filtered to prevent dirt and debris from entering the engine and causing serious and expensive damage.

Running the paver with an air cleaner that needs replacement does not allow the engine to get the proper amount of air to burn the fuel properly, which reduces engine horsepower and fuel efficiency. (Figure 3 - 9)

Periodic Maintenance

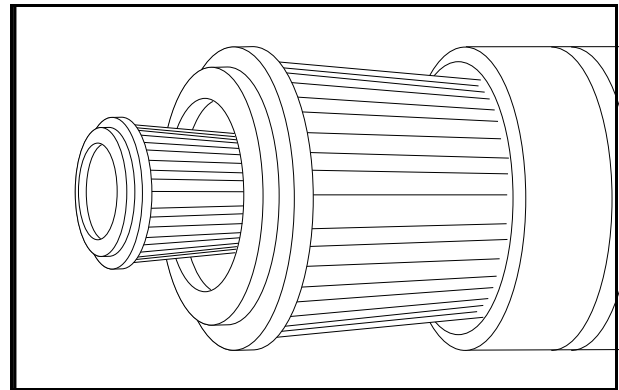

Figure 3 - 9 Engine Air Filter

When servicing an air cleaner take precautions not to allow any of the dirt or contamination that would happen to fall off the old element to remain in the filter housing or pass into the air inlet of the engine. Dirt and contamination are one of the biggest reasons for engine wear. Improper cleaning of old air cleaner elements can damage the element and allow dirt and contamination to pass directly into an engine.

Cedarapids does not recommend that air filter elements be cleaned in any way. When the air restriction indicator is operating in the red area the primary element must be replaced. The safety element must be replaced after three primary element changes.

Notice: Do not beat, shake, or use high pressure compressed air to remove dirt from an element. These methods can make small cuts in the element material which will allow dirt to enter the engine causing serious and expensive damage to the engine.

Periodic Maintenance

Engine Air Inlet Connections

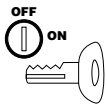

Warning: Turn off engine & remove key before performing any inspections or maintenance.

Inspect the inlet piping for cracked hoses, loose clamps, or punctures that can allow dirt and debris to enter the engine. Tighten or replace parts as necessary to make sure the air inlet system does not leak. (Figure 3 - 10)

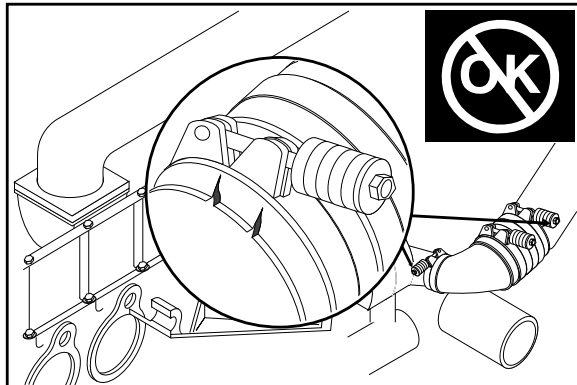

Figure 3 - 10 Air Inlets

The air inlet system includes the piping from the air cleaner to the turbocharger and the piping from the turbo charger to the after cooler or inlet manifold depending on model.

12) Engine Oil

Engine Oil Level

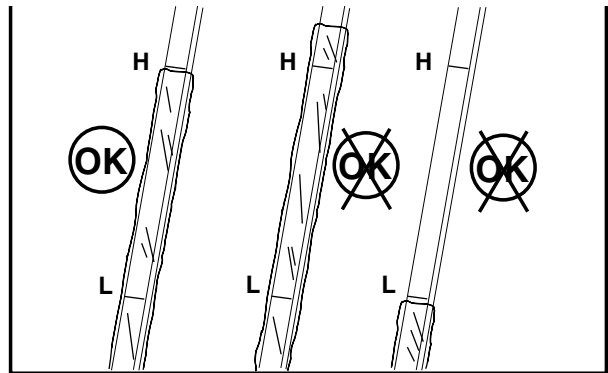

Figure 3 - 11 Checking Engine Oil Level

Never operate the engine with the oil level below the “L” (Low) mark or above the “H” (High) mark on the engine oil dipstick. Wait at least 5 minutes after shutting off the engine to check the oil. This allows time for the oil to drain to the oil pan. (Figure 3 - 11)

Important: The engine must be level when checking the oil level to be sure the measurement is correct.

Changing Engine Oil

Engine oil and filter should be changed at least every 250 hours of operation. Shorter intervals may be required due to operational conditions. Severe conditions require more frequent maintenance.

Important: Drain the oil only when it is hot and the contaminants are in suspension.

Periodic Maintenance

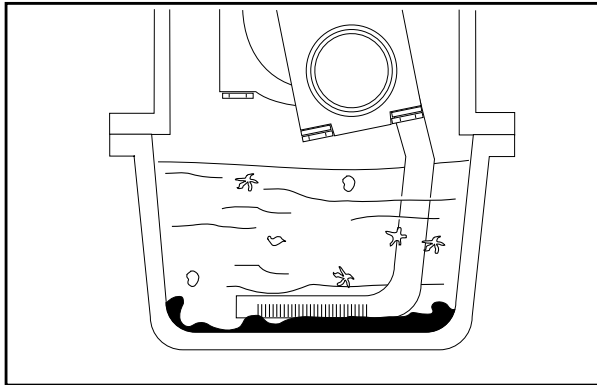

Figure 3 - 12 Oil Contaminants in Suspension

Operate the engine until the water temperature reaches 60°C [140°F]. Shut the engine off. Remove the oil drain plug and **drain oil into a container** (Figure 3 - 12).



Caution: Hot oil can cause personal injury.

Protect the environment: handling and disposal of used engine oil can be subject to federal, state and local law regulation. Use authorized waste disposal facilities, including civic sites and garages providing authorized facilities for the receipt of used engine oil. If in doubt, contact your local authorities or the EPA for guidance as to proper handling of used engine oil.

Refer to the engine manuals for the recommended type and grade of oil to be used.

13) Engine Oil Filter

Engine oil and filter should be changed at least every 250 hours of operation. Shorter intervals may be required due to operational conditions. Severe conditions require more frequent maintenance.

Use the appropriate replacement filter for your engine. See your Cedarapids dealer to be sure you are getting the correct oil filter.

Refer to Engine Service and Maintenance manuals for recommended change interval and instructions.

14) Engine Coolant

The coolant level must be checked daily. (Figure 3 - 13)



Warning: Do not remove the radiator cap from a hot engine. Wait until the temperature is below 50°C [120°F] before removing the pressure cap. Failure to do so can result in personal injury from heated coolant spray or steam. Remove the filler cap slowly to relieve coolant system pressure.

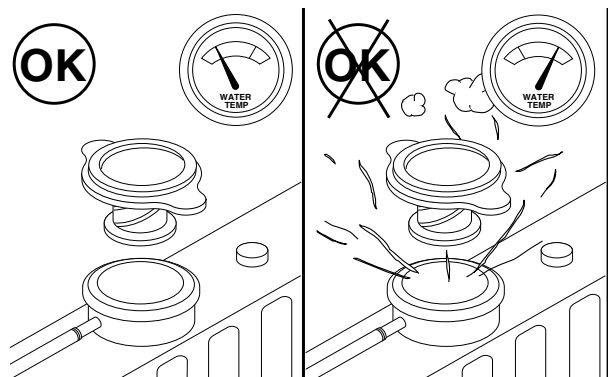

Figure 3 - 13 Hot Coolant Hazard

Notice: Do not add cold coolant to a hot engine. Engine castings can be damaged. Allow the engine to cool to below 50°C [120°F] before adding coolant.

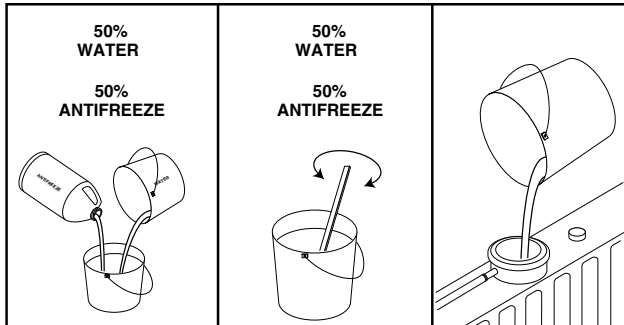

Figure 3 - 14 Adding Engine Coolant

Fill the cooling system with coolant to the bottom of the fill neck in the radiator with a 50/50 mixture of antifreeze and clean water. (Figure 3 - 14)

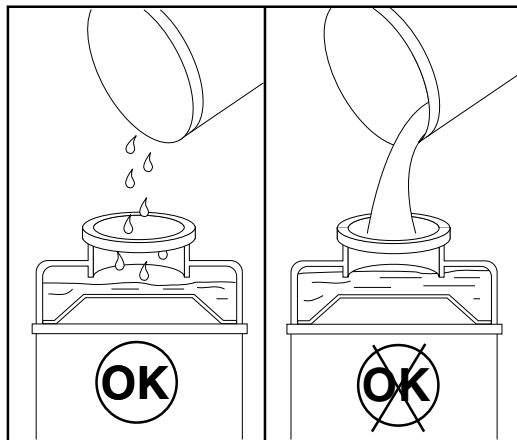
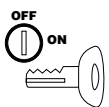

Figure 3 - 15 Do Not Overfill Radiator

Important: Do not overfill the radiator. Overfilling does not leave room for thermal expansion. Excess coolant will be forced out of the overflow. (Figure 3 - 15)

15) Engine Fan Belt



Warning: Turn off engine & remove key before performing any inspections or maintenance.

Periodic Maintenance

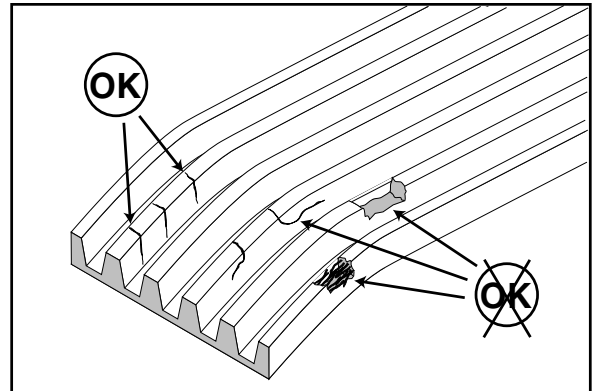

Figure 3 - 16 Engine Drive Belt Damage

Visually inspect the drive belt. Check the belt for intersecting cracks. Transverse (across the belt width) cracks are acceptable. Longitudinal (direction of belt length) cracks that intersect with transverse cracks are not acceptable. Replace the belt if it is frayed or has pieces of material missing. (Figure 3 - 16)

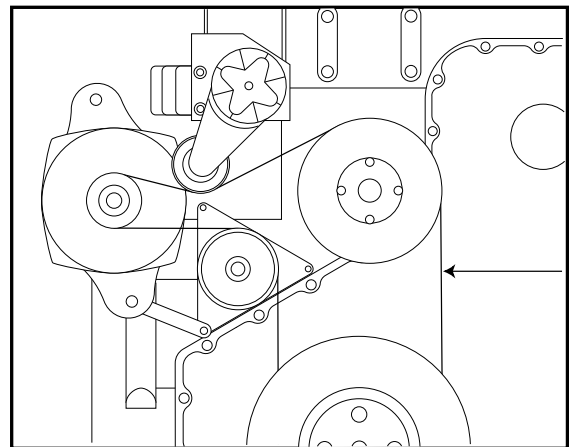

Figure 3 - 17 Checking Belt Tension

Measure the drive belt deflection at the longest span of the belt. (Figure 3 - 17)

Maximum Deflection for the Cummins 4BTA & 6BTA engines is 3/8 to 1/2 inch [9.5 to 12.7mm].

Periodic Maintenance

16) Radiator

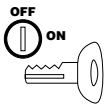

Warning: Turn off engine & remove key before performing any inspections or maintenance.

The exterior of the radiator should be checked daily for dirt and other buildup that would restrict the air flow. Paving conditions will determine how often the radiator requires cleaning. If severe conditions exist or there are a lot of air-borne contaminants the radiator will require more attention. Any fluid leaking from any engine compartment component, hose or tube will find its way into the radiator. When cleaning, check between the radiator and oil cooler for buildup. (Figure 3 - 18)

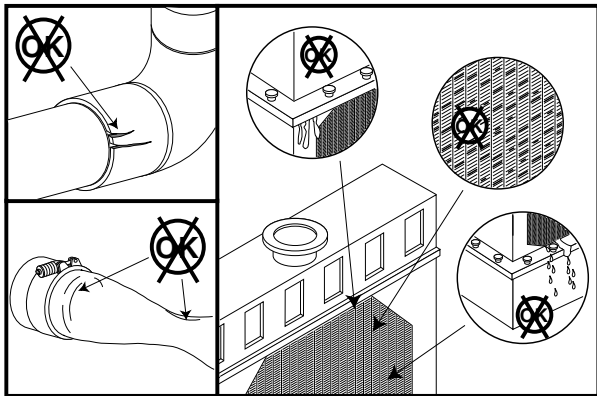

Figure 3 - 18 Radiator Damage

Check for damaged hoses and loose or damaged hose clamps. Replace as required. Check the radiator for leaks in the upper and lower radiator sections. Check the radiator core for damaged or bent fins. Clean and repair as required.

17) Engine Cooling Fan



Warning: Personal injury can result from a fan blade failure. Pulling or prying on the fan can damage the fan blade and cause fan failure.

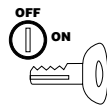

Warning: Turn off engine & remove key before performing any inspections or maintenance unless specifically instructed to the contrary in this manual.

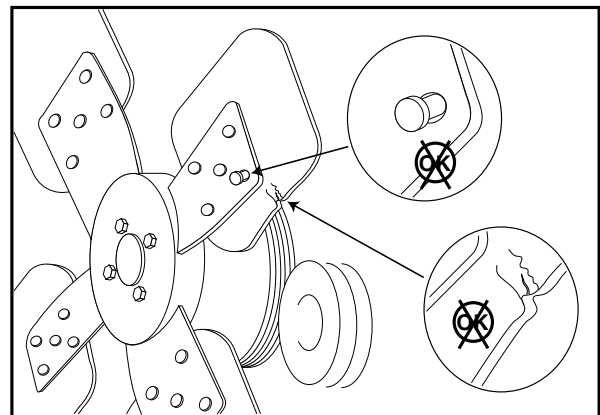

Figure 3 - 19 Fan Blade Damage

A visual inspection of the cooling fan is required daily. Check for cracks, loose rivets, and bent or loose blades. Check the fan to make sure it is securely mounted. Tighten the bolts if necessary. Replace any fan that is damaged.

18) Battery

The battery fluid level should be checked to ensure it is at the correct level.



Warning: Do Not allow open flames or sparks near batteries. Battery fumes are highly explosive.

Periodic Maintenance



Warning: Sulfuric acid in batteries is a poison and could cause severe burns. Avoid contact with skin, eyes, and clothes. When you work around batteries, protect eyes and face from battery fluid and explosion.

Checking battery fluid levels

The battery fluid level should be checked to ensure it is at the correct level. If necessary fill the battery with clean water to bring the fluid level up to the bottom of the neck of each battery cell. (Figure 3 - 20)

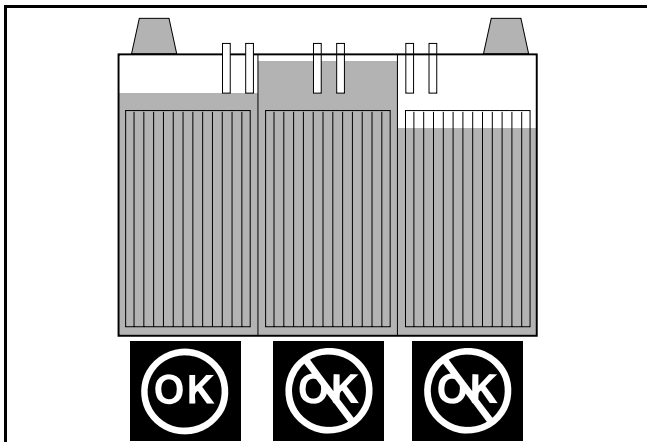

Figure 3 - 20 Battery fluid levels



Caution! When removing the battery cables, always remove the negative terminal first then the positive terminal. This will reduce the chance of sparking.

The battery terminals should be checked for corrosion buildup and tightness of connection. If necessary remove the terminal cable and clean both the battery cable connector and the battery terminal. Reinstall the positive battery cable connector first then the negative and tighten

securely. Loose or corroded connections are a prime source of starting problems and other electrical problems.

Cleaning Batteries

Make sure all the battery caps are on tight before cleaning the battery. Allowing dirt or baking soda solution into the battery will destroy the battery.

Batteries should be kept clean at all times. Wipe the outside of the battery with a cloth to remove dirt and grime.

Make sure the vent holes in the battery caps are kept open at all times to allow gas to escape from inside the battery.

To clean the battery cable and terminals, remove the battery cables and clean them with a wire brush. Soak the cables and wash the terminals in a solution of baking soda and water. Rinse the cables, battery, and battery compartment with clean water.

Checking Specific Gravity

Refer to the instructions included with your tester for specific instructions on how to use your tester.

Under normal temperature conditions, a fully charged battery will have a corrected specific gravity reading of 1.26. If the reading is below 1.2, the battery should be charged.

In very warm weather the full charged reading should be 1.225. In very cold weather the full charged reading should be 1.28.

If a battery becomes drained and has a specific gravity reading below 1.15, jump starting the engine will put a heavy load on the battery and the charging system which could damage the



Periodic Maintenance

alternator. If the specific gravity reading is below 1.15, charge the battery before using it to start the engine.

Storing Batteries

If the paver will be stored for more than 30 days, remove the batter. Make sure the battery is full charged and store the battery in a cool place.

When the battery is stored outside of the paver or while the battery is being charged, never set the battery on a concrete or dirt floor. The battery should be placed on wooden blocks.

19) Tire Pressure

The tire pressure should be maintained according to Table 3 - 2 and be equal on each side.

	CR351	CR451	CR551
Tire Pressure	30 psi	32 psi	30 psi

Table 3 - 2 Tire Pressure

The drive tires can be filled with calcium chloride and water in accordance with Table 3 - 3, if necessary, for operational conditions. This capacity puts tires to 75% full.

	CR351	CR451	CR551
Tire Size	18.4 x 26	23.1 x 26	24.5 x 32
Calcium	246 lbs	386 lbs	445 lbs
Water	586 lbs	907 lbs	1060 lbs
US Gallons	70.3	108.7	127.02
Total Weight	823 lbs	1287 lbs	1505 lbs

Table 3 - 3 Tire fluid capacity

Apply Loctite 272 to threads of lug nuts. Torque lug nuts to 267 ft.-lbs.

Periodic Maintenance

20) Frame Raise System

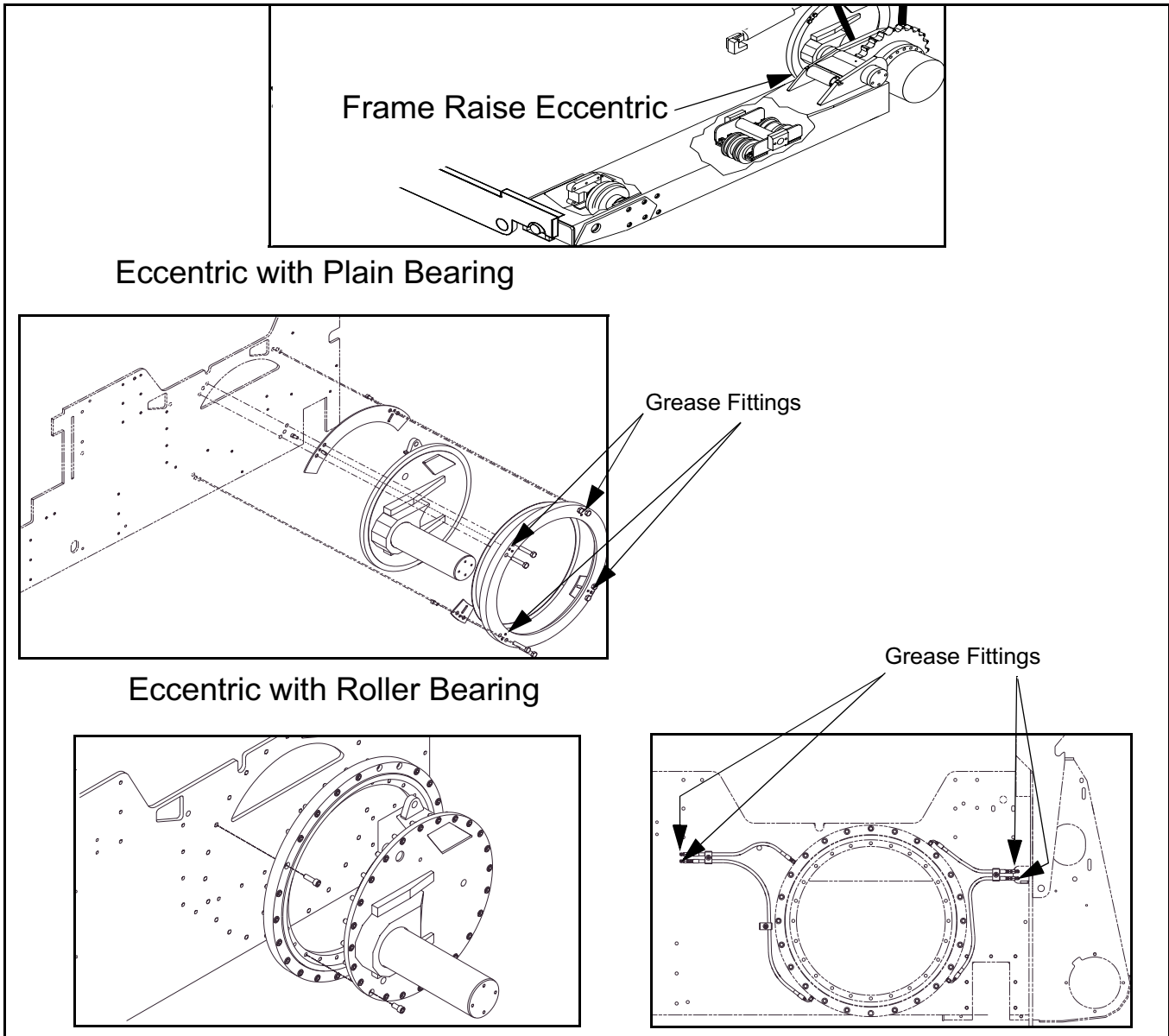

Figure 3 - 21 Frame Raise Lubrication

The paver frame raise eccentric should be greased every 500 hours of operation. (Figure 3 - 21)

Some frame raise eccentric plain bearings were assembled with Dow Corning G-N Metal Assembly Paste (P/N 49999-222) and had pipe plugs installed instead of grease fittings.

If a plain bearing is disassembled, re-assemble with Dow Corning G-N Metal Assembly Paste (P/N 49999-222).

If any frame raise eccentric bearing has pipe plugs, remove them, install grease fittings and grease at the 500 hour interval.

Periodic Maintenance

21) Steel Track Tension

The track tension on Grayhound track pavers can be adjusted to provide the desired track tension. The track has an automatic recoil system that allows the tracks to recoil if an impact is encountered then return to previous adjustment point.

Checking steel track tension

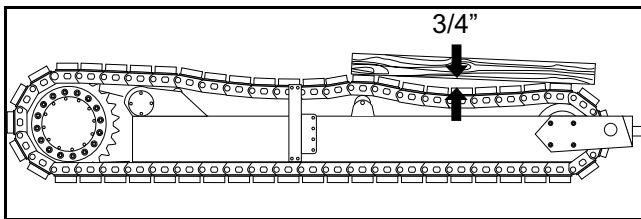

Figure 3 - 22 Checking Steel Track Tension

Set the brake switch to ON, travel lever/switch to NEUTRAL and speed dial to MIN (0) before performing checks.

The track tension should be visually checked every day before and during paver operation. If the track looks like it may be getting loose, it can be tested by placing a board or straight edge on the track between the front idler and the first top roller. If the gap between the bottom of the board and the top edge of the track is greater than 3/4", the track tension must be adjusted. (Figure 3 - 22)

Important: Perform track tension checks and adjustments when the paver is at operating temperature. Adjusting track tension when the paver is cold could lead to over-tensioning of the track.

The Grayhound track paver uses a tension cylinder mounted above the final drive that maintains a constant volume of pressurized oil to the track adjusting cylinders. When the track encounters an obstacle, the system is designed to allow the

tensioning idler to recoil rather than stretch or break the track. When the obstacle is cleared the system returns to the previous track tension adjustment.

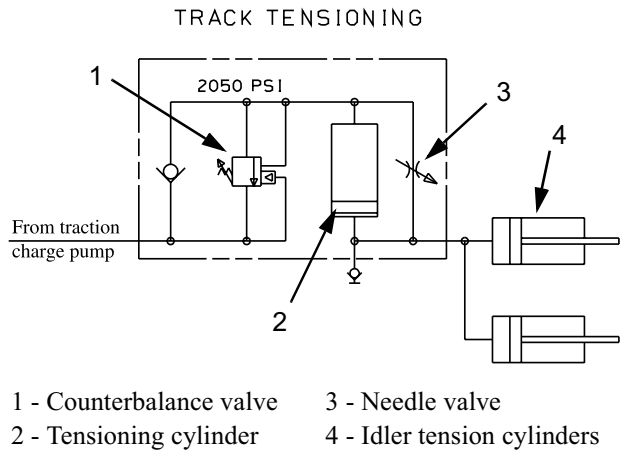

Figure 3 - 23 Steel Track tension hydraulic circuit

The track tensioning cylinder consists of a cylinder with a rodless piston, a needle valve, and a counterbalance valve. (Figure 3 - 23) The piston keeps the oil from the idler tensioning cylinders separated from the main oil supply. When the track encounters an obstacle it forces oil from the idler cylinders into the bottom side of the tensioning cylinder. When the obstruction is cleared, pressurized oil from the traction charge pump forces the tensioning cylinder down which forces the idler cylinders to move back to the original position.

The needle valve is used during track tensioning to bring the volume of oil on the bottom side of the tensioning cylinder back to the proper level. The counterbalance valve allows oil flow freely from to discharge to tank from the top side of the tension cylinder when the track encounters an obstacle.

Periodic Maintenance

Steel Track over-pressurizing

If the track adjusting system is over-pressurizing during operation the following procedure must be performed. It is a good idea to perform this check once each season to verify the tensioning cylinder is in good condition.

Notice: Do not run the paver while the system is over-pressurized. Running with an over-pressurized system could damage the track and sprockets.

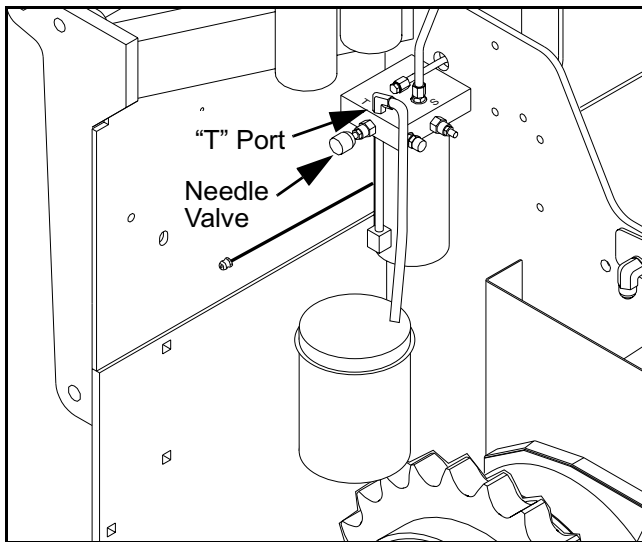

Figure 3 - 24 Adjusting steel track tension

- 1) Disconnect the line from the “T” port on the track tension cylinder. Install a plug into the disconnected line. (Figure 3 - 24)
- 2) Attach a drain line to the “T” port and run the other end into a bucket.
- 3) Close the needle valve by rotating clockwise.
- 4) Start the engine and run at full throttle.
- 5) If the track was tensioned properly, no oil will flow into the bucket.

- 6) If only a small amount of oil drains into the bucket, the piston and counterbalance valve are working properly and the track will be properly tensioned.
- 7) If oil continues to flow into the bucket, the piston or counterbalance valve is leaking and must be repaired.
- 8) Turn the engine off and reconnect the hydraulic line to the “T” port.

Tightening Steel Track

- 1) Start the engine.
- 2) Drive the paver forward very slowly.



Warning: Be very careful when reaching over the moving track. Keep feet and loose clothing away from the moving track and rollers.

- 3) Open the needle valve slowly to allow the track to retension. (Figure 3 - 24)
- 4) Close needle valve and stop paver.

Steel Track Relief Pressure

In addition to adjusting the track tension, the track relief pressure should be checked at least once each season. Refer to the Paver Technical Manual for information on checking track relief pressure.

Periodic Maintenance

21A) Rubber Track Tension

The tracks on Grayhound rubber track pavers (Figure 3 - 25) do not require periodic adjustment. They are self-adjusted by applying a pre-set hydraulic pressure supplied by the auxiliary pump to the tensioning cylinders. The tracks have an automatic system that allows them to recoil and return to tension if a severe impact is encountered. If tracks appear loose, troubleshoot the track hydraulic system (see Section 5).

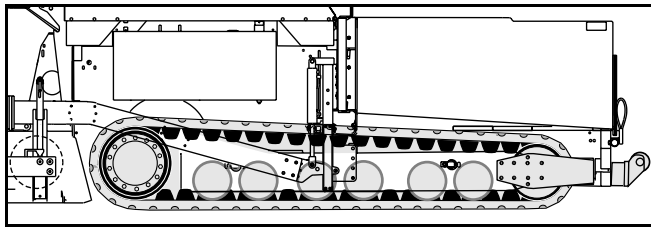

Figure 3 - 25 Rubber Track

22) Track Pivot

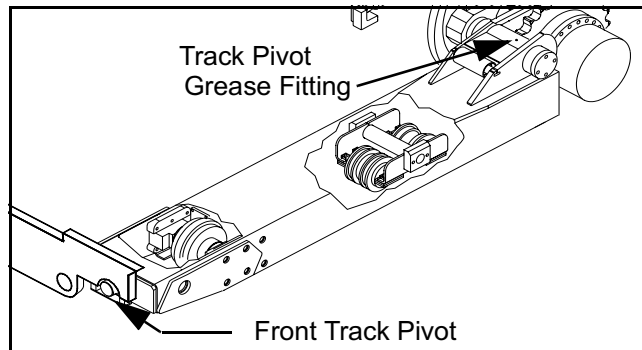

Figure 3 - 26 Track Pivot

The track pivot should be lubricated every 40 hours of operation. (Figure 3 - 26) The rear pivot has a grease fitting and the front pivot should be lubed with heavy grade oil.

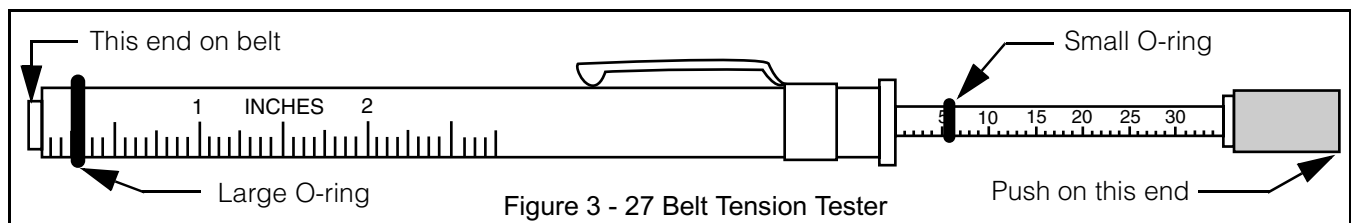

Figure 3 - 27 Belt Tension Tester

23) Fire Extinguisher

The fire extinguisher should be inspected every 250 hours to ensure the extinguisher is fully charged and has not been damaged.

24) Horn

It is essential that the horn is maintained in working order at all times for safety reasons. Before starting the engine each day the horn should be sounded to ensure it is in working order.

25) Pump Drive Belts

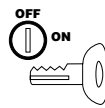

Warning: Turn off engine & remove key before performing any inspections or maintenance.

Notice - Do not overtighten belts. Overtightening belts can cause premature belt and/or bearing failure.

Notice - Make sure the belt tension gauge is used correctly. Pushing the wrong end of the tester onto the belt will give an incorrect belt tension reading. (Figure 3 - 27)

Periodic Maintenance

Tension Checking Procedure

- 1) Raise Hood
- 2) Loosen belt access covers.
- 3) Position the bottom of the large O-ring on the tester at the deflection indicated in Table 3 - 4. Set the small O-ring on the tester to zero.
- 4) Locate the midpoint on the belt and place the belt end of the tester onto the belt.

Notice -The tension tester must be inserted perpendicular to the belt to accurately measure belt tension.

- 5) Place the tester on the belt perpendicular to the belt. Mark the tester at the point where the tester meets the top of the access cover. It may be necessary to place a straightedge over the belt access hole to accurately mark this position.
- 6) Set the large O-ring 1/4" (6.4 mm) above the mark. (Figure 3 - 31)
- 7) Push on the yellow tipped plunger until the bottom of the large O-ring is level with the straightedge.
- 8) Remove the tester and read the belt deflection force in pounds at the small O-ring. Compare this with the value in (Table 3 - 4). If the force is outside the listed limits the belt should be retensioned. (Figure 3 - 28)



Figure 3 - 28 Tester Used Correctly

Poly Chain Belts

Poly chain belts are designed to provide years of reliable service without stretching. As a result, adjusting the belt tension is **rarely required**. Do not adjust the poly chain belts unless they test below the Minimum setting found in Table 3 - 4.

Tension values for poly chain belts are temperature-sensitive. When installing belts, either new or used, adjust the belts for an 8 to 10 lb setting at 1/4 in deflection when the belts are cold. After the machine is at normal operating temperature (minimum of 2 hours of continuous paving operation), use the values listed in Table 3 - 4.

Periodic Maintenance

Poly Chain Belts			
		Force	Deflection
*At Operating Temperature	Min	18 lbs/8.2 kg	1/4" 6.4 mm
	Max	20 lbs/9.1 kg	
Cold Equipment	Min	8 lbs/ 3.6 kg	
	Max	10 lbs/4.5 kg	

Table 3 - 4 Poly chain belt tension settings

* **Notice** - Check poly chain belt tension only after the **entire** machine is at operating temperature (minimum of two hours of continuous paving operation).

Do not adjust the belts until they test below the MINIMUM setting when the machine is at normal operating temperatures. Adjusting the belts to the values in Table 3 - 4 when the belts are cold will result in rapid belt failure and possibly damage to pump bearings. Adjust up to (but not exceeding) the MAX setting when the machine is at normal operating temperature.



Figure 3 - 29 Tester Used Correctly

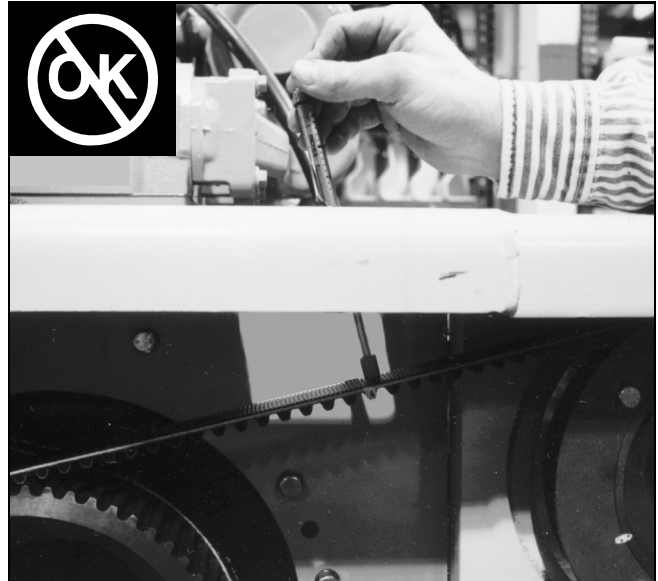

Figure 3 - 30 Tester Used Incorrectly

All poly chain adjustments are to be made at 1/4 inch deflection.

The following illustrations demonstrate the correct and incorrect ways to use the belt tension tester.

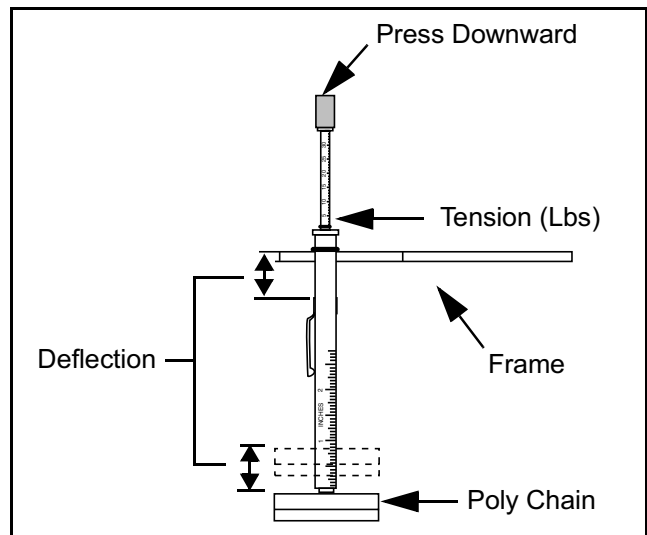

Figure 3 - 31 Testing Poly Chain Belts

Periodic Maintenance

26) Depth Cranks

The screed depth crank assemblies have two lubrication points on each, one on the threaded link and the other on the screed depth crank bearing housing. These should be lubricated every 40 hours of operation. One to two pumps from a hand grease gun is all that is necessary.

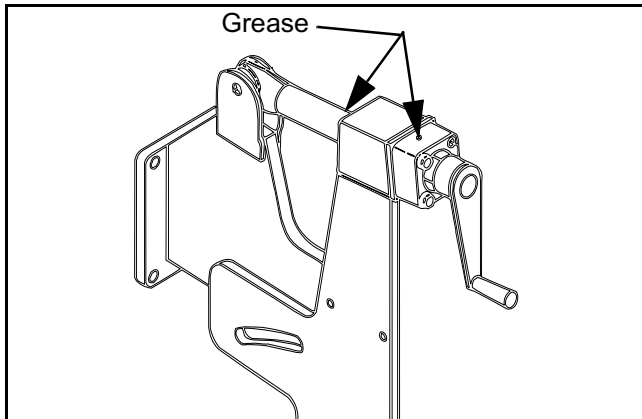

Figure 3 - 32 Depth Crank Lubrication

27) Vibrator Bearings

The vibrator assemblies have four lubrication points, one on each vibrator bearing. The grease fittings are remote plumbed to the upper lip of the screed frames. They should be lubricated every 8 hours of operation. One to two pumps from a hand grease gun is all that is necessary. (Figure 3 - 33)

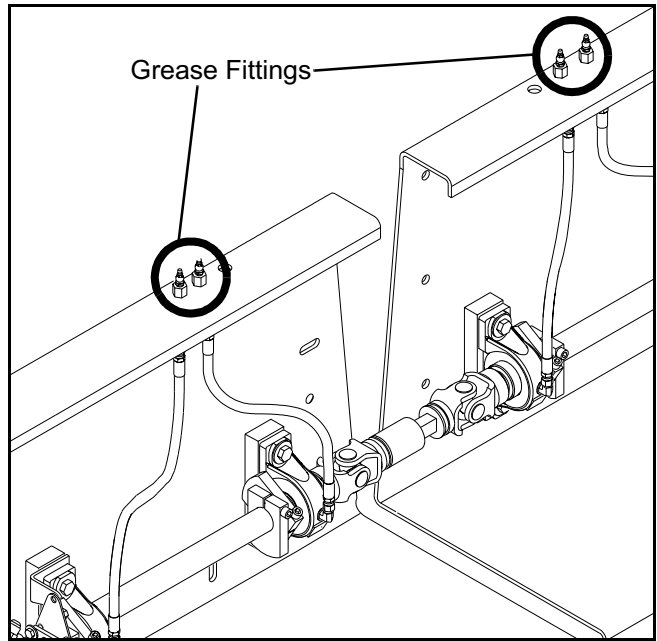

Figure 3 - 33 Vibrator Lubrication

28) Crown Control

The crown control has two lubrication points one on each turnbuckle assembly. They should be lubricated every 40 hours of operation. One to two pumps from a hand grease gun is all that is necessary. (Figure 3 - 34)

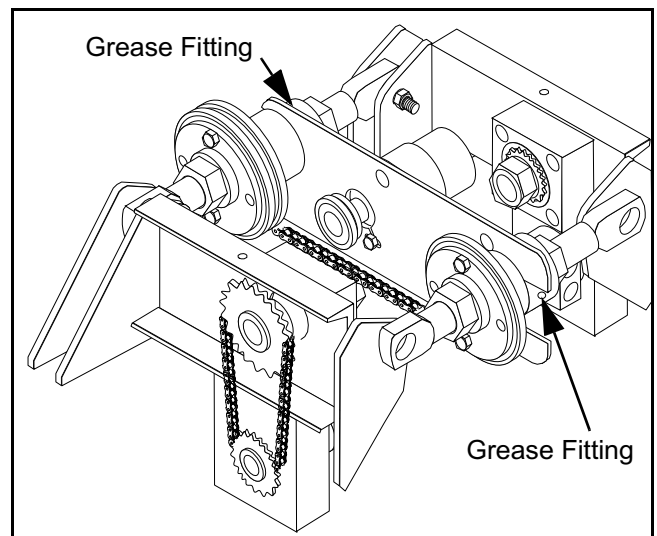

Figure 3 - 34 Crown Control Lubrication

Periodic Maintenance

29) Match Height Assembly

The match height assemblies have two lubrication points on each, one on the threaded link and the other on the match height bearing housing. These should be lubricated every 40 hours of operation. One to two pumps from a hand grease gun is all that is necessary.

30) Extension Slope Assembly

The extending screed slope assemblies have two lubrication points on each, one on the threaded link and the other on the slope shaft bearing housing. These should be lubricated every 40 hours of operation. One to two pumps from a hand grease gun is all that is necessary.

31) Final Drive Oil

The final drive planetary oil level should be checked during the first 40 hours of operation and replaced at 150 hours of operation. Drain, flush and refill every 1000 hours of normal operation.

To check the oil level, rotate the drive until the fill plug is straight up and the level check plug is 90 degrees down from the fill plug. Remove the level check plug. The oil level should be even with the bottom of the level check plug hole. If the oil level is low remove the fill plug and add oil to bring the level up to the bottom of the level check plug hole. (Figure 3 - 35)

Note - Verify there is no hydraulic oil in the final drive housing before adding gear oil. Hydraulic oil in this housing indicates leakage from the brake or hydraulic drive motor.

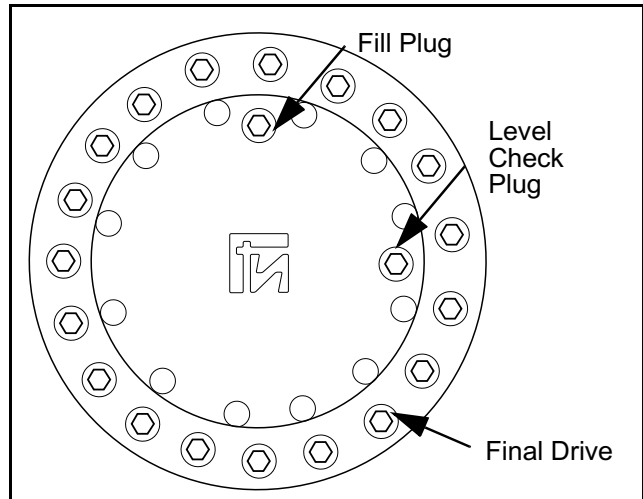

Figure 3 - 35 Checking Final Drive Oil Level

Use 80W-90 Gear Oil when adding or replacing final drive oil. Typical brands: Amoco Multipurpose gear Lube 80W-90, Texaco Multipurpose Gear Lube 80W-90, Mobilube HD 80W-90, Exxon Gear Oil GX 80W-90, Shell Spirax HD 80W-90. An ISO Grade 150 EP oil can be substituted for those given above.

32) Steering Bogie Alignment

It is normal for the bogie wheel to get slightly out of alignment during normal operation. Driving with misaligned bogie wheels can make steering difficult and increase wear of the bogie tire. (Figure 3 - 36)

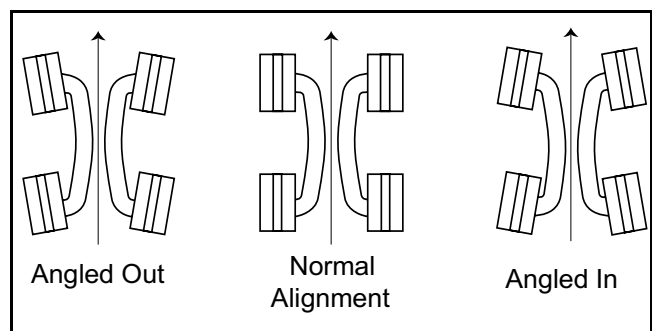

Figure 3 - 36 Bogie Wheel Alignment

Periodic Maintenance

If the bogie wheels are angled in or out the wheels will need to be realigned. Realigning the bogie wheels is accomplished without the use of any tools and can be performed any time the paver is parked.

To synchronize the steering bogies:

- 1) Stop the paver and run the engine at full throttle.
- 2) Turn the steering wheel to the left or right until a resistance is felt. Continue turning the steering wheel for 1 to 2 more revolutions.
- 3) Turn steering wheel back to the center position and continue paving.

33) Steering Linkage

Lubricate the steering linkage rod ends every 250 hours. (Figure 3 - 37)

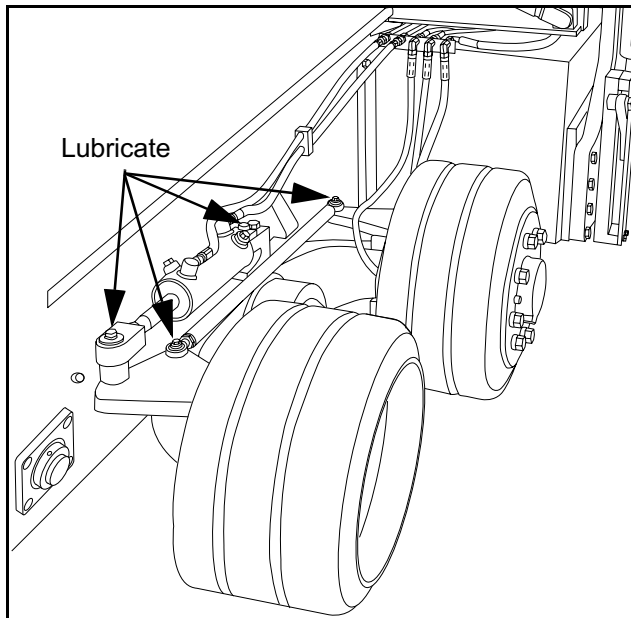

Figure 3 - 37 Steering linkage lubrication

The steering linkage, rod ends, bushings, bearings and cylinders should be checked seasonally for adjustment and possible wear.

34) Bogie Beam Bearings

The bogie beam bearings should be lubricated every 250 hrs.

35) Front Wheel Bearings

The wheel and pivot bearings should be checked and repacked with Lithium base, type EP, Grade 2 grease yearly.

36) Bogie Wheel Toe-in

Wheel alignment and amount of tow-in should be adjusted as necessary. Normal amount of tow-in required is approximately 1/16 to 1/8 inch. (Figure 3 - 38)

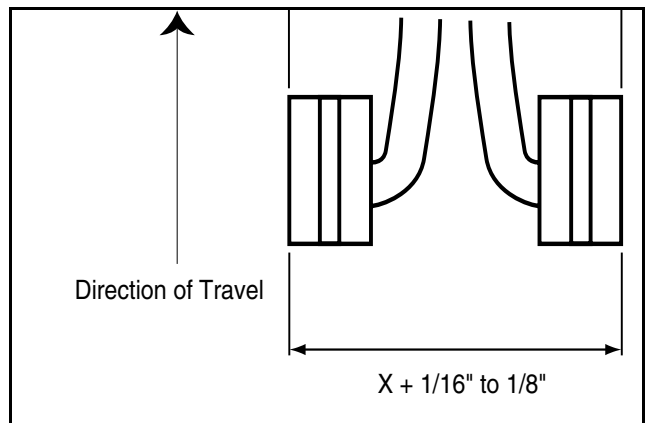

Figure 3 - 38 Bogie Toe-in

Periodic Maintenance

37) Delivery Auger Clearance

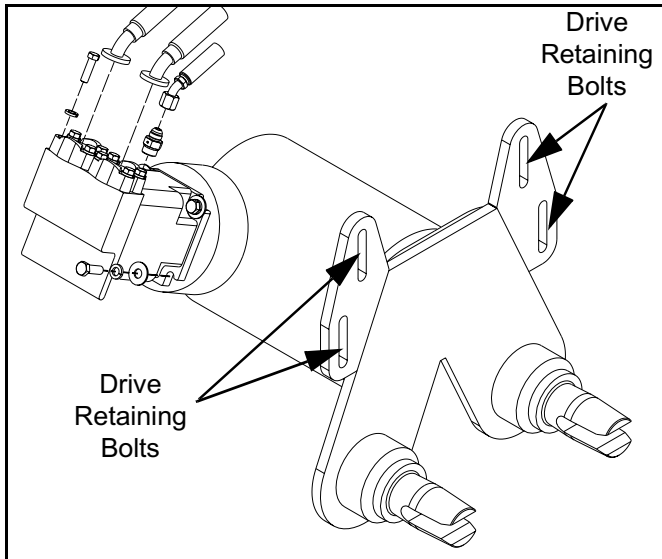

Figure 3 - 39 Delivery Auger Adjustment

As the delivery auger wears the spacing between the auger flighting and liner will increase. This spacing should be the same on both ends and greater than the largest aggregate diameter used in the asphalt mix. Inspect at 40 hours of operation and adjust every 120 hours of operation.

Notice - Recommended clearance is 1 - 1/4" min. to 1 - 3/4" max. (Figure 3 - 40)

To adjust auger spacing:

- 1) Loosen four drive retaining bolts on gearbox and reposition drive end augers.
- 2) Next, loosen hopper end of augers retaining bolts and reposition augers.
- 3) Make sure augers are positioned to recommended clearance between 1 - 1/4" min. to 1 - 3/4" max. at both ends of augers.
- 4) Tighten all bolts to lock in place.

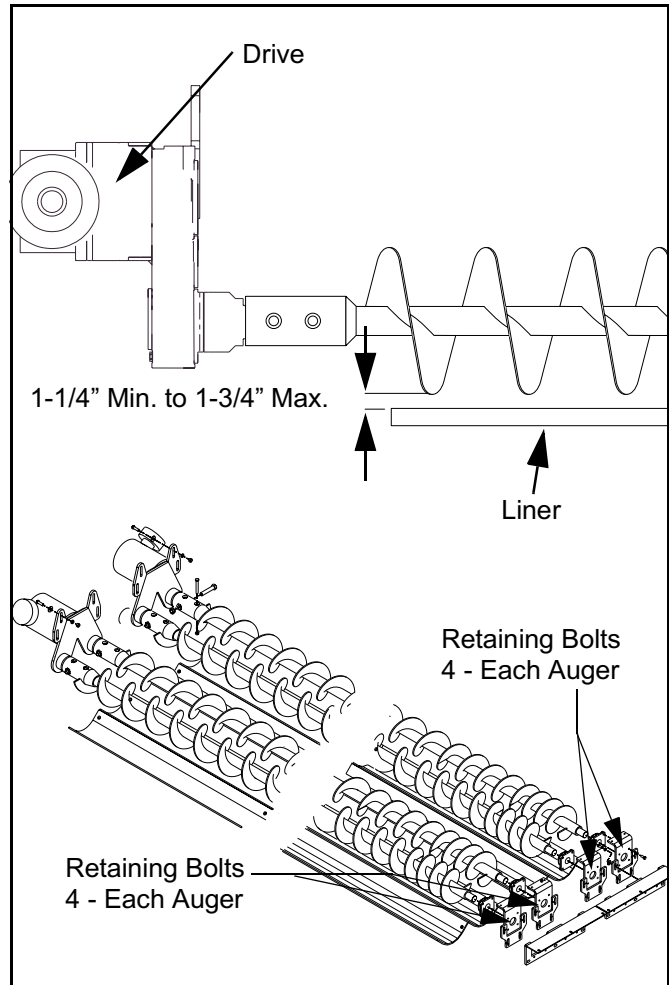

Figure 3 - 40 Setting Auger to Liner Spacing

38) Delivery Auger Drive - Gear Drive

Each delivery auger gear drive speed reducer oil level should be checked every 40 hours and replaced every 1000 hours of operation. The oil is at the correct level when the oil is just above the sight glass (check at style A or B). (Figure 3 - 41)

Use 80W-90 gear oil in the speed reducer. Typical brands: Amoco Multipurpose gear Lube 80W-90, Texaco Multipurpose Gear Lube 80W-90, Mobilube HD 80W-90, Exxon Gear Oil GX 80W-90, Shell Spirax HD 80W-90. An ISO Grade 150 EP oil can be substituted for those given above.

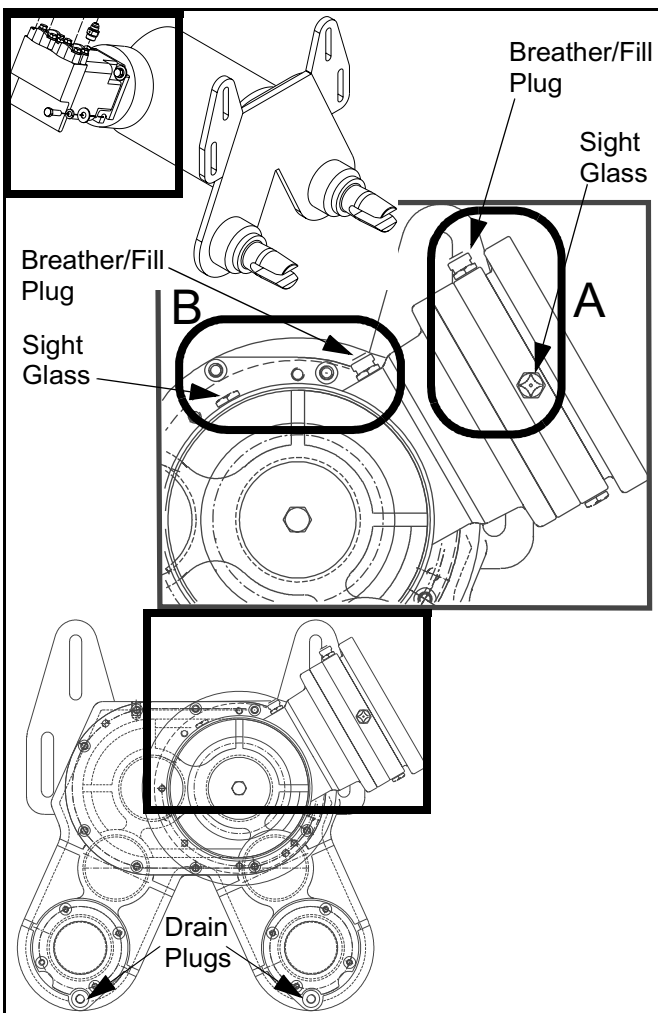

Figure 3 - 41 Delivery Auger Drive Gear Drive

Periodic Maintenance

39) Front Delivery Auger Bearings

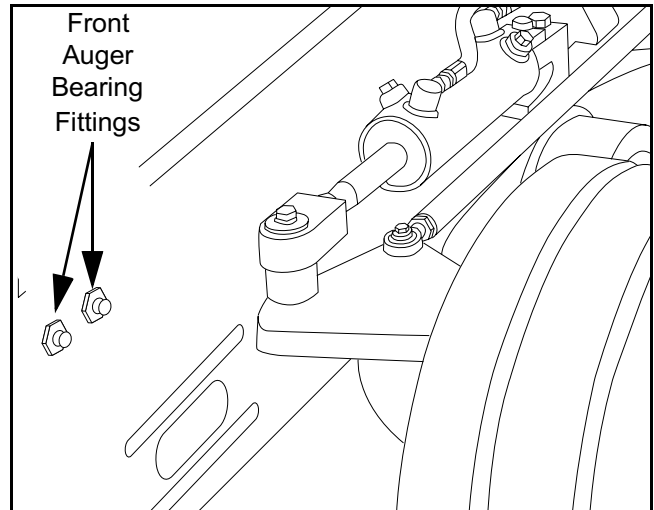

Figure 3 - 42 Front Delivery Auger Bearings

The front delivery auger bearing on each of the four augers should be lubricated every 8 hours of operation with Lithium base, type EP, Grade 2 grease. (Figure 3 - 42)

40) Spreading Auger Bearings

The spreading auger bearings should be lubricated every 8 hours of operation with Lithium base, type EP, Grade 2 grease. (Figure 3 - 43)

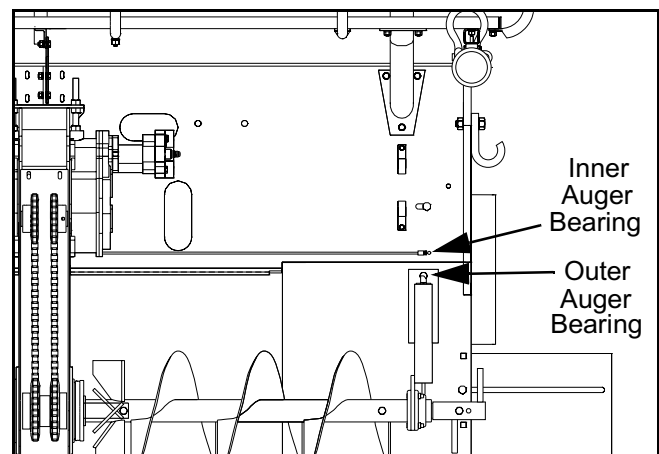

Figure 3 - 43 Spreading Auger Bearings

41) Spreading Auger Drive Chains

The spreading auger drive chains should be checked every 40 hours of operation. Check the drive chains for proper tension and wear. Check the bronze spacer washer between the auger drive sprockets for wear. Clean the housing and lubricate the chains and spacer with fuel oil from the spray-down hose or with SAE 10 motor oil. A small amount of oil may be left in the housing for lubrication between checks even though the housing is not oil tight.

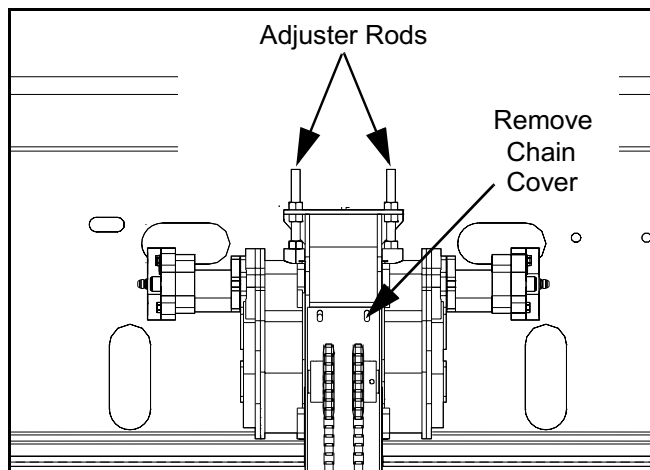
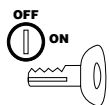

Figure 3 - 44 Adjusting Spreading Auger Drive Chain



Warning: Turn off engine & remove key before performing the following inspections or maintenance.

- 1) Remove the cap screws holding the spreading auger drive chain cover. Pull the cover back and off. (Figure 3 - 44)
- 2) Loosen the jam nuts on the drive chain adjuster rods.
- 3) Using the adjuster rods, remove the slack from the chain, but do not over tighten. At the correct tension, the chain should move slightly under thumb pressure.

Periodic Maintenance

- 4) After both chains have been tensioned properly, tighten the jam nuts. Replace the cover.

42) Spreading Auger Speed Reducer



Warning: Turn off engine & remove key before performing the following inspections or maintenance.

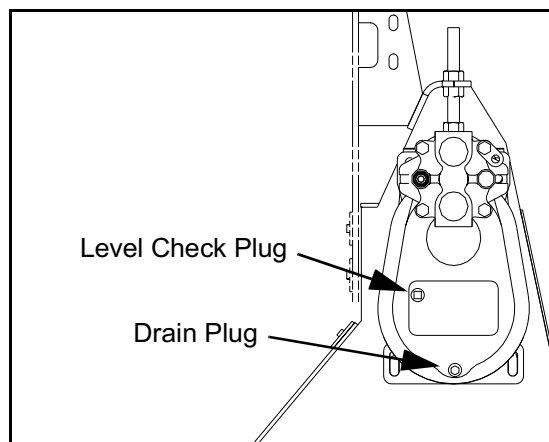

Figure 3 - 45 Spreading Auger Speed Reducer

The spreading auger speed reducer oil level should be checked in the first 40 hours and replaced every 1000 hours of operation. The oil is at the correct level when the oil is level with the bottom threads of the level check plug. (Figure 3 - 45)

Use 80W-90 gear oil in the spreading auger speed reducer. Typical brands: Amoco Multipurpose gear Lube 80W-90, Texaco Multipurpose Gear Lube 80W-90, Mobilube HD 80W-90, Exxon Gear Oil GX 80W-90, Shell Spirax HD 80W-90. An ISO Grade 150 EP oil can be substituted for those given above.

Periodic Maintenance

43) Hood Raise Reservoir

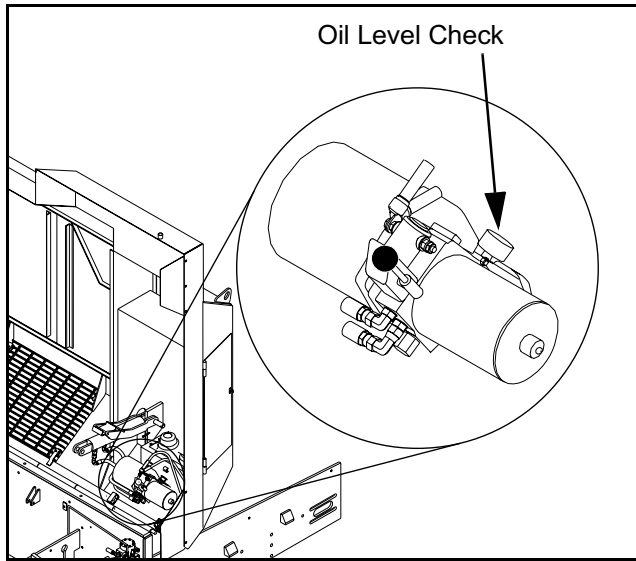

Figure 3 - 46 Hood Raise Reservoir

The hood raise reservoir oil level should be checked periodically. Use AW 68 hydraulic oil in the hood raise reservoir. (Figure 3 - 46)

44) Operator Console Pivot Bearings

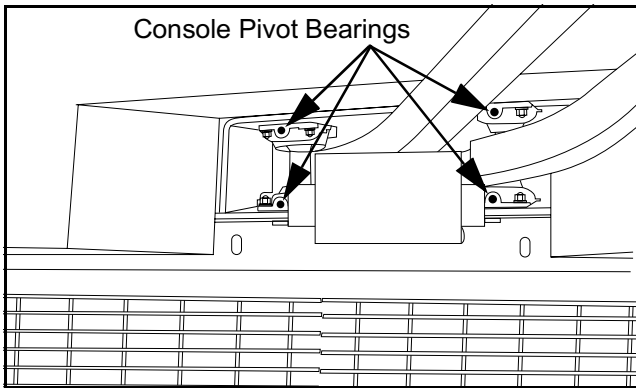

Figure 3 - 47 Operator Console Pivot Bearings

The operator console pivot should be lubricated every 250 hours of operation. (Figure 3 - 47)

45) Tow Arm Nose Roller

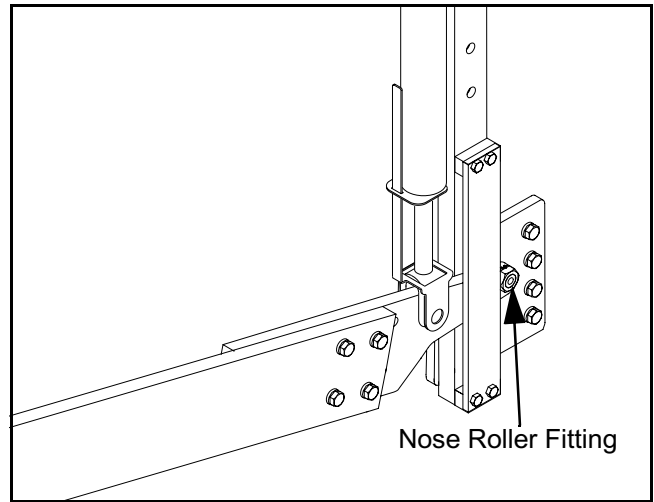

Figure 3 - 48 Tow Arm Nose Roller

The tow arm pull point roller should be lubricated every 8 hours of operation. (Figure 3 - 48)

46) Slope Beam Rod Ends

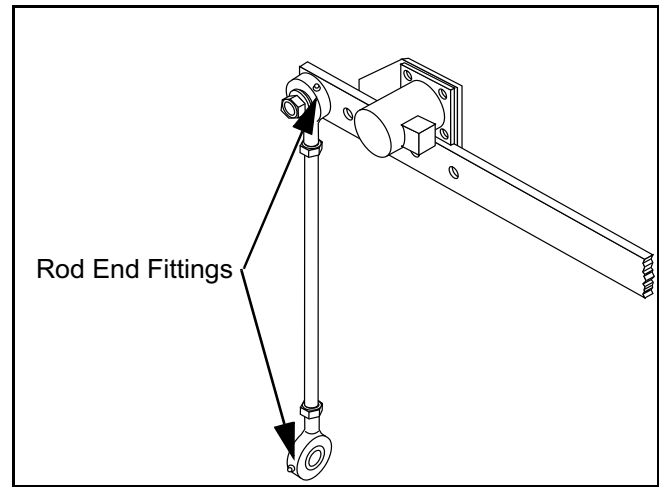

Figure 3 - 49 Slope Beam Rod Ends

The slope beam rod ends should be lubricated every 250 hours of operation. (Figure 3 - 49)



Periodic Maintenance

47) Truck Hitch

The truck hitch should be cleaned as part of the daily cleaning to remove any asphalt that has collected on the truck hook or rollers. Spray the truck hook and rollers with diesel fuel during spraydown.

48) Fume Recovery System

The fume recovery system vacuum indicator should be checked each day before beginning operation. With the engine running at full throttle, the vacuum indicator should register a reading. When the vacuum indicator reading is too low, components of the fume recovery system require maintenance. Refer to (Table 3 - 5) for troubleshooting information.

Problem	Cause	Remedy
Low vacuum reading	Low hydraulic pressure to fume recover fan motor. Damaged, collapsed or disconnected fume recovery hoses between fume recovery fan and muffler. Plugged or collapsed fume recovery hoses between fume recovery fan and muffler.	Refer to paver hydraulic schematic Repair, replace, or reconnect hoses Clean or replace fume recovery hoses.
High vacuum reading	Plugged fume recovery hoses between fume recovery fan and fume recovery hoods.	Clean or replace fume recovery hoses.
Visible fumes escaping from hoods	Fume recovery system not operating properly.	Ensure fume recovery system is completely installed. Check vacuum indicator system.

Table 3 - 5 Fume Recovery System Troubleshooting

Periodic Maintenance

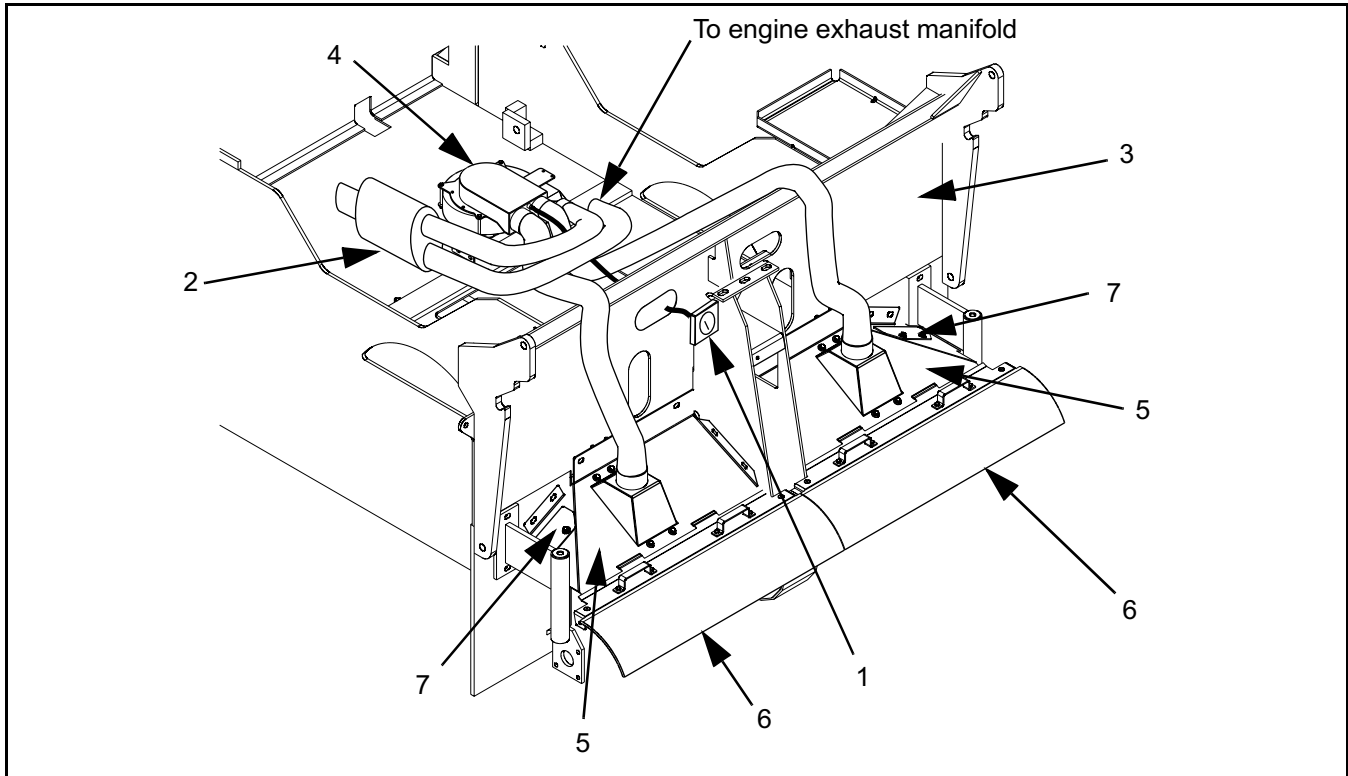

- | | |
|-------------------------|--|
| 1 - Vacuum Indicator | 5 - Fixed Fume Recovery Hood Section |
| 2 - Muffler | 6 - Auger Access Hood Section |
| 3 - Paver Rear Bulkhead | 7 - Proportional Feed Sensor Mounting Hole |
| 4 - Fan | |

Figure 3 - 50 Fume Recovery System Components

Fume Recovery System Repair

- 1) Check hoses and tubes for cracks, cuts, dents, or collapsed spots. Cuts or cracks may be repairable with duct tape. Repair or replace tubes as needed (Figure 3 - 50).
- 2) Check interior surfaces of hoses and tubes for asphalt buildup. Clean tubes and hoses by soaking in solvent and brushing clean. Hoses and tubes may be more economically replaced than cleaned.
- 3) Disassemble the fan for cleaning using the following procedure (Figure 3 - 51):
 - a) Disconnect tubes from left and right hoods and to muffler.
 - b) Disconnect hose to vacuum indicator.
 - c) Remove four bolts retaining inlet manifold to fan assembly and remove inlet manifold.
 - d) Lift off fan housing.
 - e) Remove bolt and two washers retaining fan wheel to motor shaft.
 - f) Remove fan plate by removing four bolts.

Periodic Maintenance

- 4) The parts removed in the previous step can all be cleaned by soaking in solvent and cleaning with a brush.
- 5) Reassemble fan in reverse order. When installing fan wheel, use Loctite 242 on the bolt and torque to 110 in-lb.

Note - Fan housing is sealed with RTV silicone.

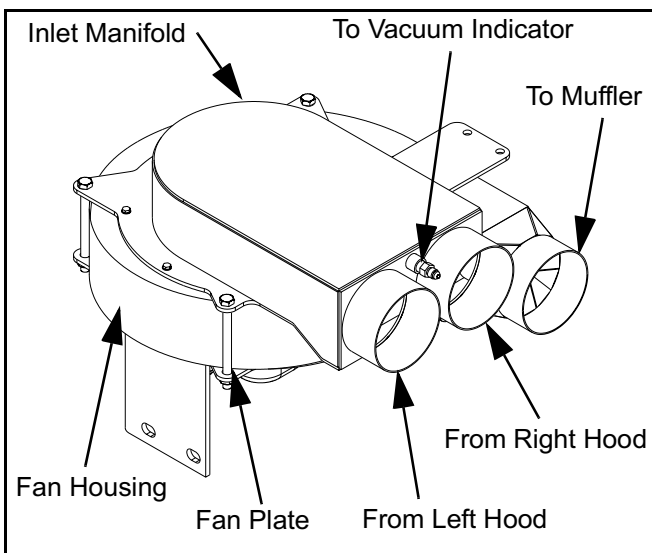

Figure 3 - 51 Fume Recovery Fan Disassembly

At least once each year, the system should be thoroughly inspected to ensure proper operation.

- 6) With the engine warmed up, lower the screed and run the engine at full throttle.
- 7) Read the vacuum from the vacuum indicator mounted on the rear bulkhead. If the reading is low or has no reading, the fume recovery tubing may be dirty, plugged, collapsed, damaged, or disconnected.
- 8) Record the vacuum reading and any required maintenance in (Table 3 - 6).

Starting the Engine

Section 4 - Operating the Tractor

Starting the Engine

- 1) Make sure all personnel are clear of the paver and aware that the paver is going to be started.
- 2) Set the Master Key Switch to the ON position. The Master Key Switch on older 400 series pavers can be found inside the toolbox on the right side of the machine. On newer 400 series machines the Master Key Switch can be accessed through an access door in the hood on the left side of the operator platform.

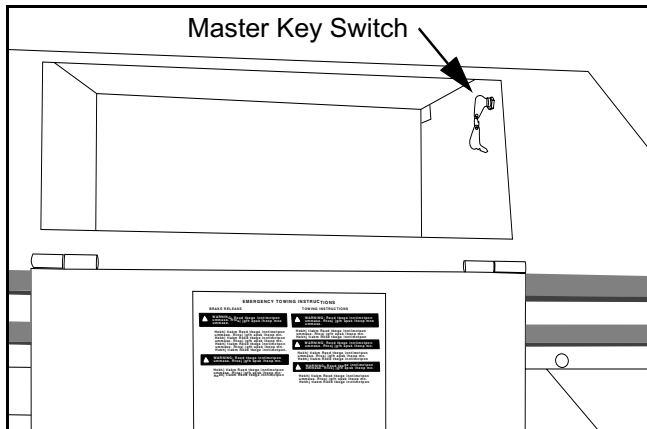

Figure 4 - 1 Master Key Switch Toolbox Location

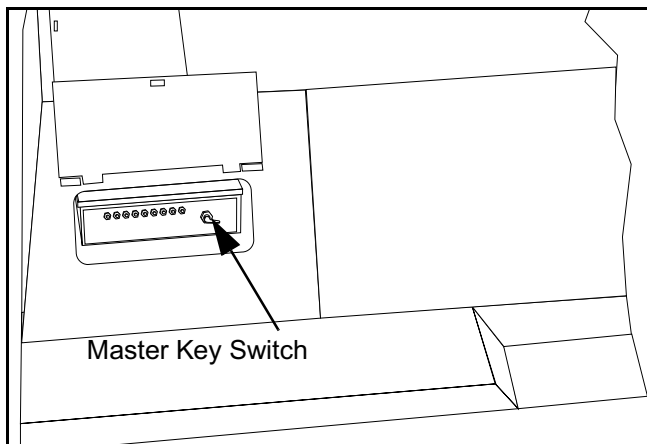

Figure 4 - 2 Master Key Switch Platform Location

- 3) Set the console switches and controls as follows:

Left and Right Feed Conveyors	Off
Vibrators	Off
Screed Assist	Off
Range	Pave
Brake	Engage
Throttle	Idle
Counter Rotate	Normal
Rear Frame Compensator	Off
Paver Speed	"0" (Min.)
Travel Direction	"N" (neutral)

Table 4 - 1 Prestart switch settings

Important - The engine will not start if the console switches are not set as indicated in Table 4 - 1 .

- 1) Pull the permissive start switch down and the engine start/stop switch up. The paver should start. If the engine does not start after 30 seconds, release both switches and let the starter cool down before cranking the engine again.

Once the engine starts, release the engine start/stop switch but continue to hold the permissive start switch engaged. If the permissive start switch is released before the engine oil pressure reaches 5 lbs. the engine will stop immediately. This system is designed to protect the engine when the engine oil pressure drops below 5 lbs. or the engine temperature rises above 223 degrees F.

Starting the Engine

Important - After the engine oil pressure is above 5 lbs. and the engine temperature is below 223 degrees F, the Engine light will go out and the permissive start switch can be released.

Once the engine is running, allow it to idle for at least 5 minutes to warm up before bringing the engine throttle to full throttle.

Engine start-up after stall

Under certain conditions the engine could stall while under load. If the operator attempts to restart the engine immediately after it stalls, the engine will be trying to start under full load. This could overload and damage the starter.

If the engine stalls under load, allow 5 to 10 minutes for the hydraulic system pressures to “leak down” before trying to restart the engine.

Jump starting/ charging batteries



Warning: Batteries give off explosive hydrogen gas when charging. Keep flame and sparks away from the battery while jump starting or charging.

Notice: Grayhound pavers use a 12 Volt electrical system. When jump starting or charging the paver, make sure to use a 12 Volt power source.

- 1) Raise the hood. Refer to the Raising the Hood section in this manual.
- 2) Connect the jumper cables to the power source.

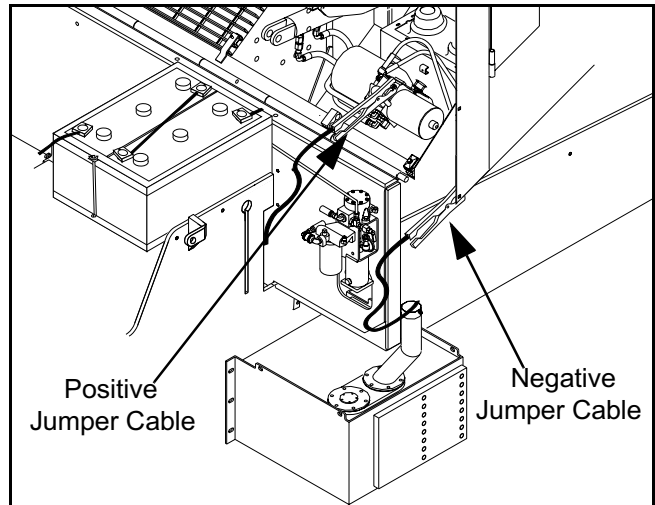

Figure 4 - 3 Jumper Cable Connection Points



Warning: When jumper cables or a battery charger are connected or disconnected from a battery, a spark will be created when the first cable is disconnected or the last cable is connected. For this reason it is critical that the first cable disconnected and the last cable connected be the negative (-) cable and that this connection be made as far away from the battery as possible.

- 3) Connect the positive (+) cable to the positive (+) battery terminal or power terminal on the hood raise power pack motor.
- 4) Connect the negative (-) cable to the paver frame away from the battery. The negative (-) cable should always be connected away from the battery so that any sparks created by making the connection do not ignite the hydrogen gas that is produced by the battery.
- 5) As soon as the engine starts, remove the jumper cables.

Starting the Engine

Emergency towing

If your paver becomes disabled and the engine can not be started it may be necessary to tow the paver. Grayhound Pavers have a parking brake that automatically engages anytime the engine is not running. Before towing a paver the brakes must be released and the travel pumps put into bypass.



Warning - Read all of the towing instructions before starting this procedure.



Warning - Block or restrain the paver before releasing the brakes. Failure to block or restrain the paver could result in serious injury or death.



Warning - When towing the paver using the following procedure, the paver will not have drive, braking, or steering control. Do not travel down steep grades which could cause the paver to collide with the towing vehicle.

- 1) Insert an allen wrench into the internal hex of each system check relief valve plug and remove plugs (Figure 4 - 4).
- 2) Remove valve poppet assemblies from each port and set aside in a clean, safe place.
- 3) Reinstall plugs on each port.

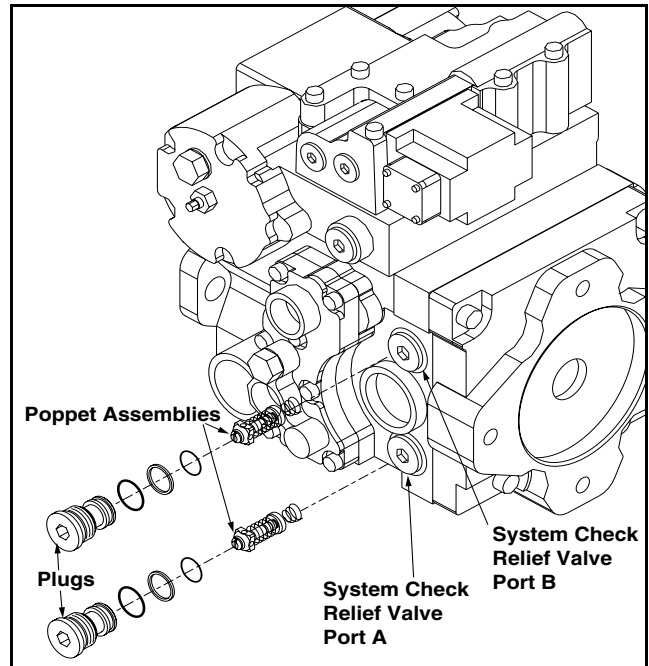

Figure 4 - 4 Travel Pump Bypass

- 4) Disconnect tube from brake solenoid valve located on rear bulkhead, right hand side. Place a cap on the valve fitting to keep dirt out of the hydraulic system.

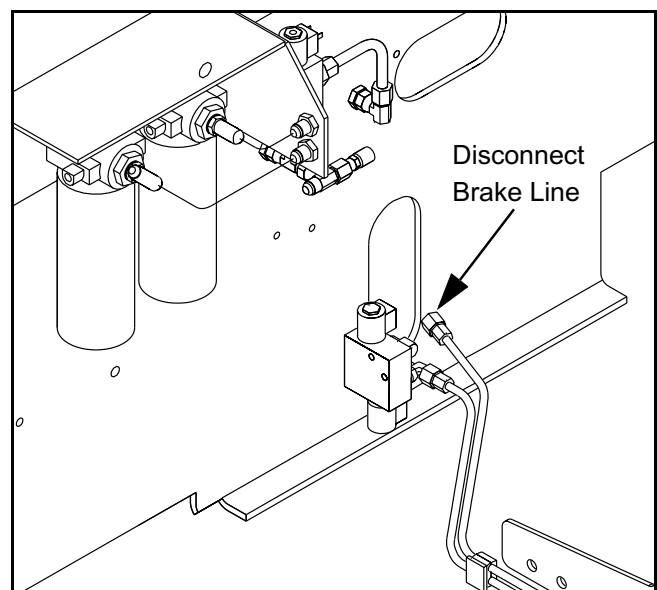

Figure 4 - 5 Preparing to release brakes

Starting the Engine

- 5) Attach a porta-power to open hose end and pump the pressure up to at least 350 psi to release the brakes. The brakes can be reapplied by releasing the pressure at the porta-power.

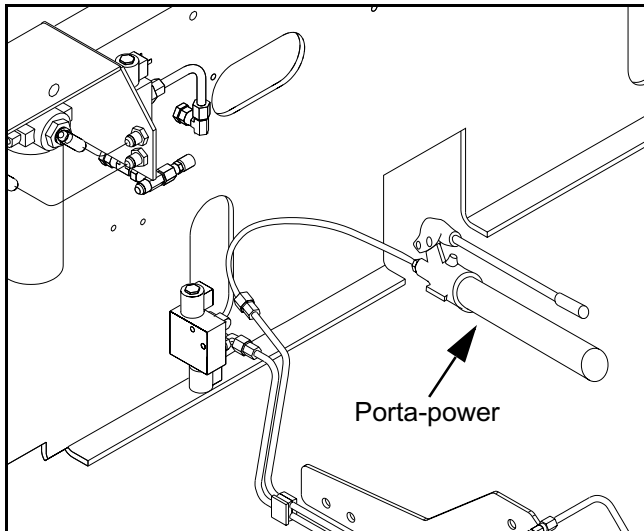

Figure 4 - 6 Releasing Brakes with Porta-power

Notice: Maintain a minimum of 350 psi to fully release the brakes. Do not exceed 1500 psi.



Warning - Use a chain in good condition that is capable of pulling the paver.

- 6) Open the front conveyor bearing covers.
- 7) Run the chain through the holes shown.

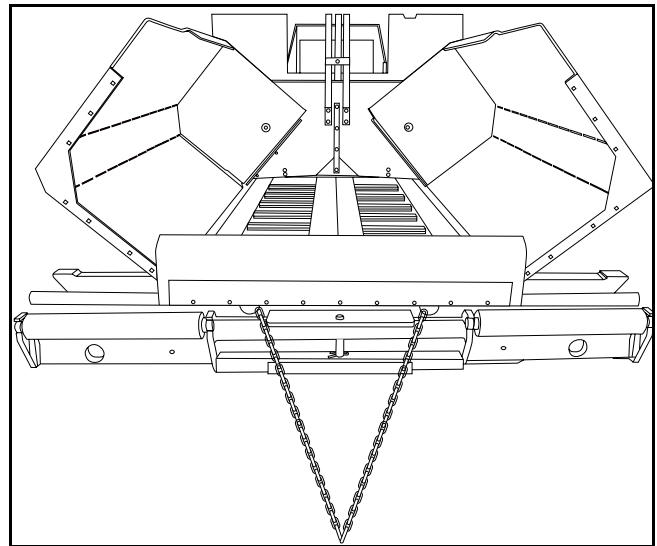

Figure 4 - 7 Attaching chain for towing

Notice: Attaching chains to the push roller frame or truck hook frame could result in serious and expensive damage.

- 8) Slowly apply tension to chains to start paver moving. Move the paver at a very slow walking pace.
- Notice:** Pulling the paver faster than 25 feet per minute can result in serious and expensive damage to the travel system.
- 9) When the paver is in desired location, release the pressure at the porta-power and reconnect the hose to the brake valve.
 - 10) Insert an allen wrench into the internal hex of each system check relief valve plug and remove plugs (Figure 4 - 4).
 - 11) Reinstall valve poppet assemblies into each port.
 - 12) Reinstall plugs on each port.

Loading/Unloading

Loading/Unloading

Driving the Paver off a Trailer

The paver can be loaded or unloaded from various kinds of trailers. When loading or unloading a paver the clearance from the ground to the auger or screed becomes a concern. Some trailers will require construction of a ramp long enough so the augers or screed will not drag on the ground.

Notice - Always use the frame raise system to raise the rear of the paver as high as possible before loading or unloading the paver. The screed or augers could be damaged if they drag on the ground.

Grayhound pavers have a Frame Raise feature which allows the rear of the paver to be raised during loading and unloading. The paver should be raised as high as possible for maximum ground clearance during loading or unloading.

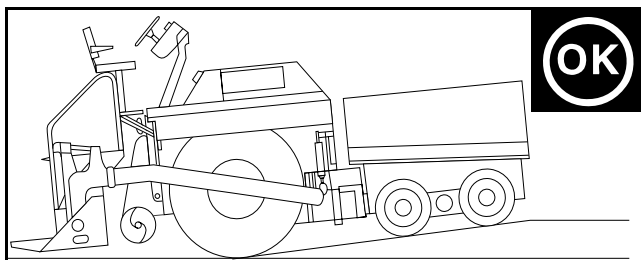

Figure 4 - 8 Sufficient ground clearance

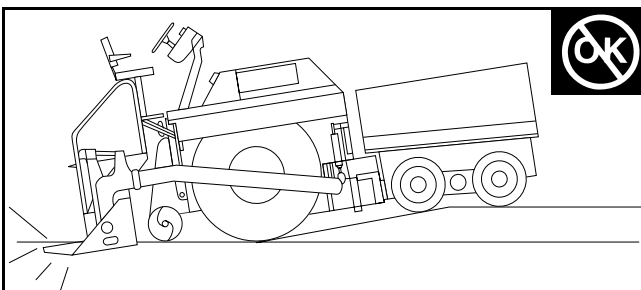

Figure 4 - 9 Insufficient ground clearance

The screed should always be raised and the screed lock hooked when loading or unloading the paver. If the paver cannot be loaded or unloaded without the screed dragging the ground, the screed can be removed.

Notice - If the screed is removed, carefully watch the augers to make sure they do not drag on the ground during loading and unloading.

Notice - All constructed ramps must be capable of supporting the total machine weight.

Notice - Rubber Tracks can be damaged by sharp objects on the surface of ramps or trailer when loading and unloading.

To move the paver on or off a trailer:

- 1) Remove all chains and binders from the paver frame.
- 2) Start the engine.
- 3) Raise the screed and hook the screed lock.
- 4) Use the frame raise system to elevate the rear of the paver as much as possible.
- 5) Have a person on the ground to help guide you on or off the trailer.
- 6) Set the Pave/Travel switch to Pave (P2 on rubber tired models) and Speed Dial to 0.
- 7) Bring the engine to Full throttle.
- 8) Place the brake switch in the Release position.

Loading/Unloading

- 9) Place the Travel Direction switch in the direction needed.
- 10) Slowly increase the setting on the speed dial until the paver starts moving. It is safer to use a slow speed while loading or unloading.

You can use the brake switch to engage the brakes in an emergency.



Warning - If the brakes are used to stop a moving paver, the paver will stop suddenly. The brakes should be used to stop the paver only in an emergency.

Lifting with crane

Ensure the crane and cables to be used are capable of supporting the total machine weight safely.

Attach one cable to each of the two lifting points on the rear of the paver (Figure 4 - 11). Loop a chain through the lifting eyes at the front of the paver and attach it to the crane hook (Figure 4 - 10).

The two rear cables must be of equal length and the front cable/chain must be adjusted to two equal lengths.

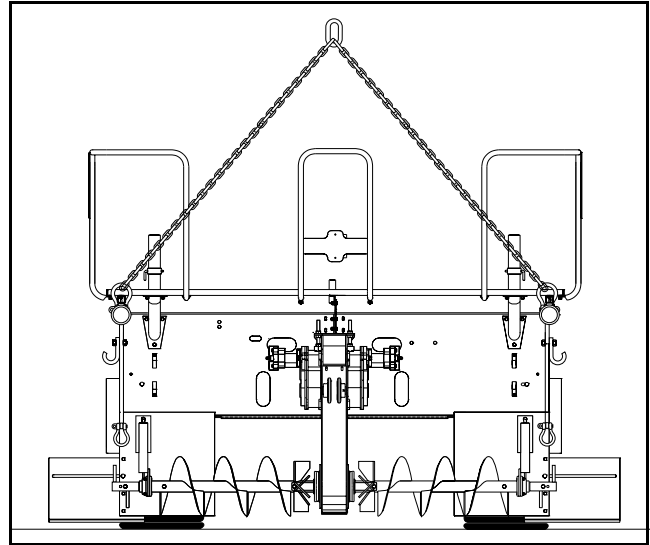

Figure 4 - 11 Rear lift points



Warning - Each lifting cable must be hooked to the crane hook independently. Do not loop a single lifting cable through the crane hook and back to a second lifting point.

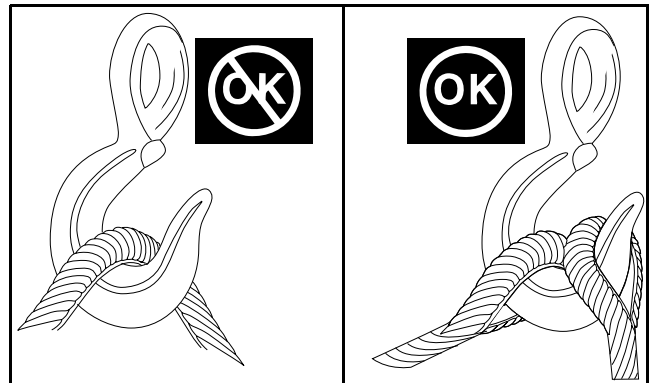

Figure 4 - 12 Attach cables correctly

Raise the screed and lock it into position. Older Grayhound models have a cable attached to the tow arm that is hooked into the screed hooks on the rear of the tractor. (Figure 4 - 13)

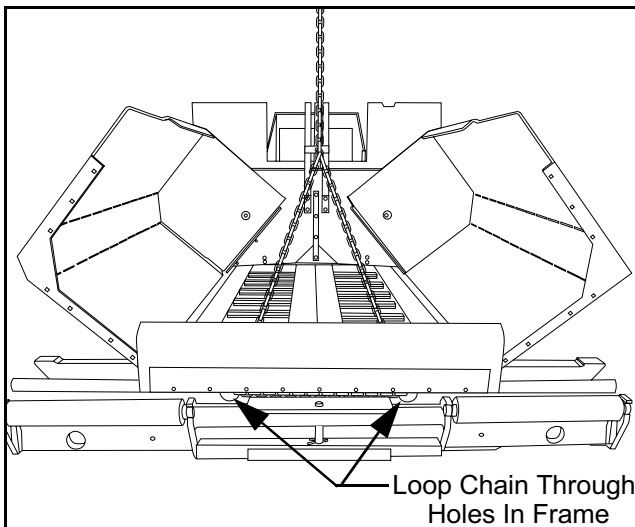

Figure 4 - 10 Front lift points

Loading/Unloading

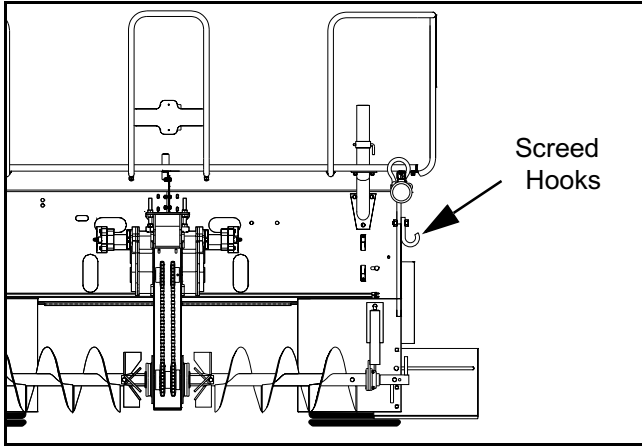

Figure 4 - 13 Screed Cables

Newer units use an integrated screed lock that engages automatically when the screed is fully raised. Stepping on the screed release pedal allows the screed to be lowered. (Figure 4 - 14)

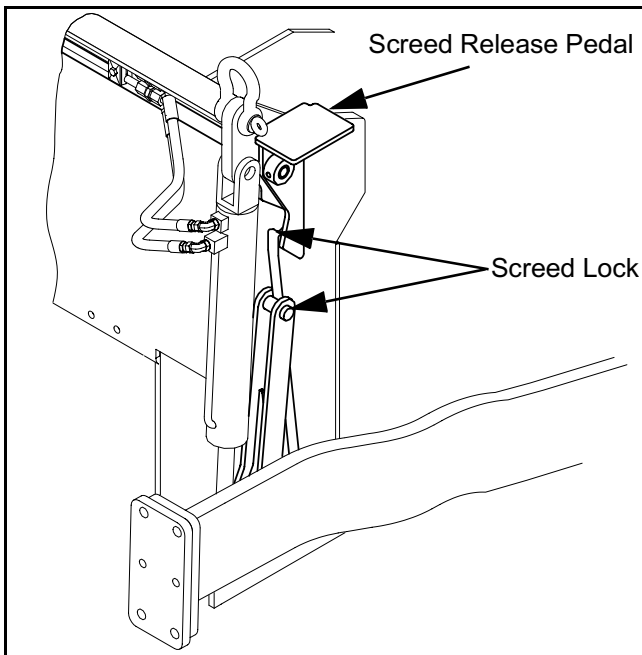

Figure 4 - 14 Screed Lock

The paver engine should not be running while the paver is being lifted by a crane.

Preparation for transport

Preparation for transport

- 1) Load the paver onto the trailer or truck.
- 2) Lower the screed onto blocks at each end and in the center of the screed. Never set the screed on nails, rivets, or bolt which could damage the screed bottom.

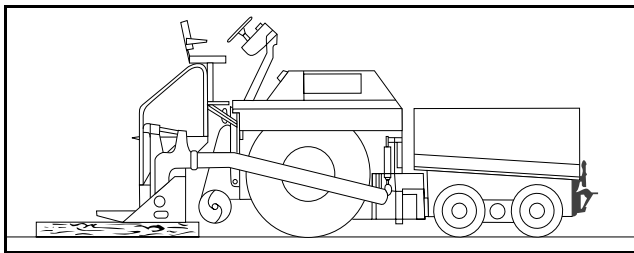

Figure 4 - 15 Set screed on blocks

- 3) Use the frame raise switch on the operators console to lower the rear of the paver as much as possible.
- 4) Use chains and chain binders to tie the paver down in the front (Figure 4 - 16) and rear (Figure 4 - 17) of the paver.

Chaining directly to the screed, truck hook, or tow arms could damage the equipment. All chains should be secured to the paver frame only.

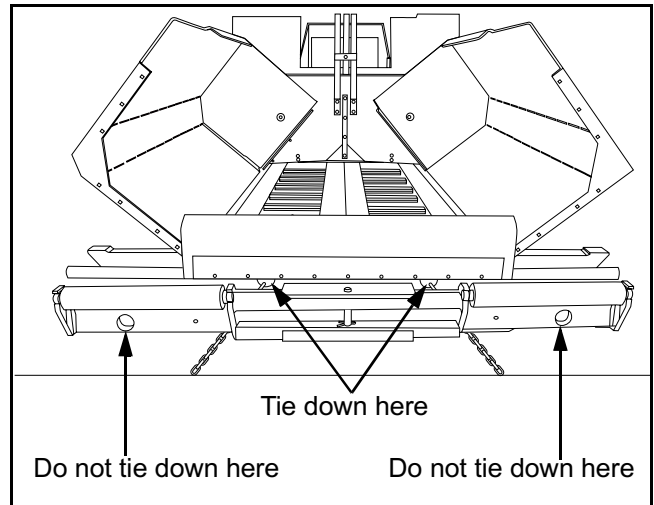

Figure 4 - 16 Front tie down points

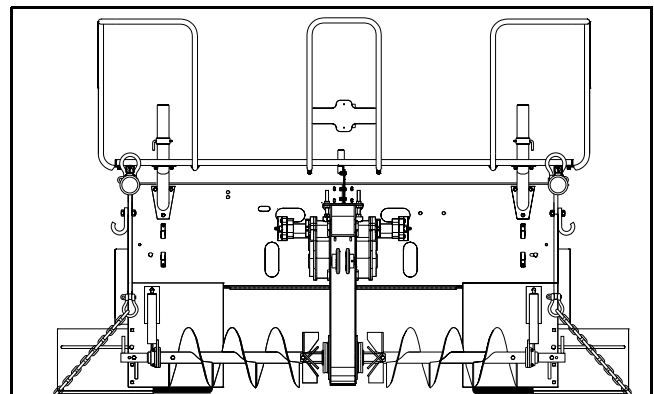

Figure 4 - 17 Rear tie down points

Preparing to Pave

Preparing to Pave

Fume Recovery System

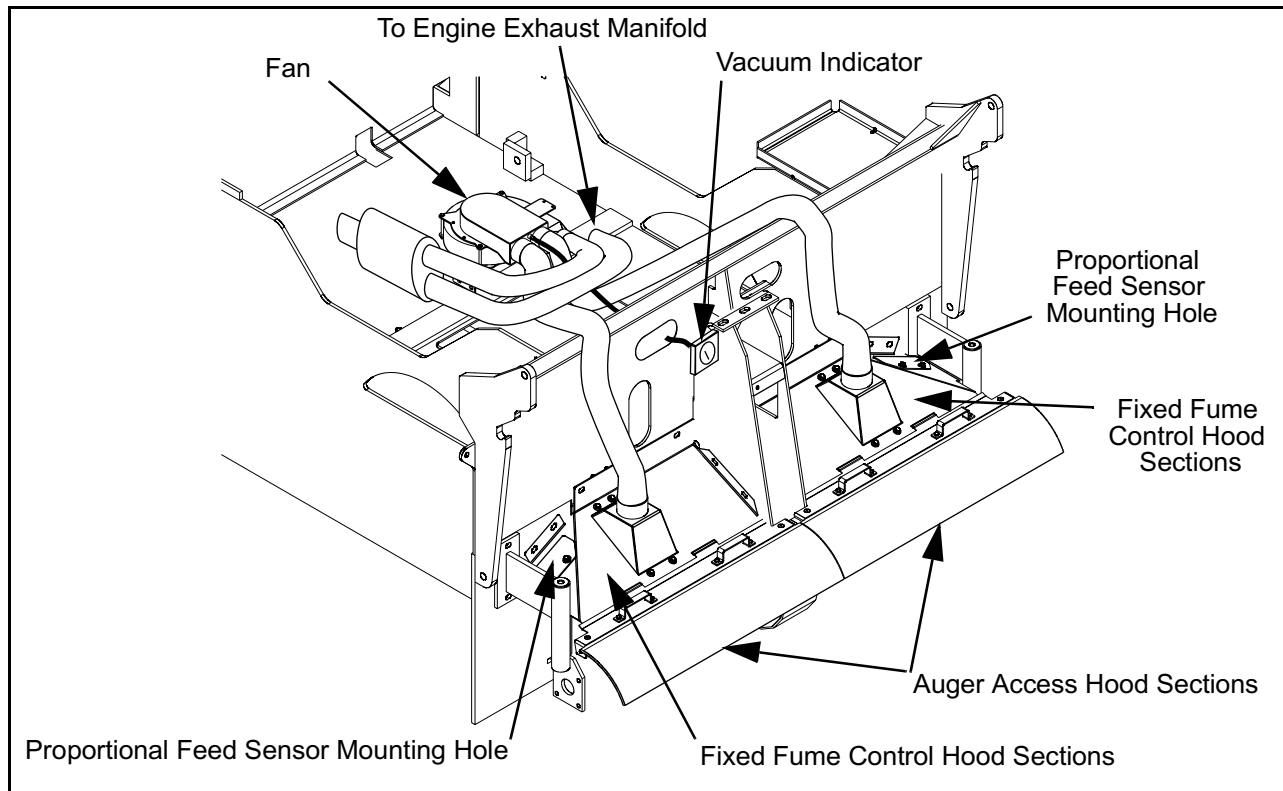

Figure 4 - 18 Fume recovery system

The fume recovery system is designed to collect fumes given off by hot mix asphalt and discharge them away from operator work areas. The auger access hood sections can be removed to gain access to the main spreading augers. Refer to (Figure 4 - 18). This may be necessary for cleaning the augers and to check the condition of the augers. The system is designed to meet minimum emission standards with or without the auger access hood sections installed. However, to operate at maximum effectiveness, the auger access hood sections should be installed during operation.

Automatic feed sensor mounting hole covers can be removed to install a proportional feed sensor. If a proportional sensor is not used, the mounting hole covers should be reinstalled.

The fume recovery fan starts automatically when the engine is started and continues to run while the engine runs. The vacuum indicator should be checked each day before starting paving. The indicator should register a vacuum reading with engine running at full throttle. A low or no reading indicates a malfunction in the system. Refer to Section 3 for system troubleshooting.

Preparing to Pave

Nulling screed

Important - the following information on setting up the screed is only a portion of the information available on the subject. The Quality Paving Guide should be read completely and be kept with the paver for reference on setting up the screed.

When we null a screed, we are adjusting the angle of attack on the screed to 0 in relation to a given or desired depth. This is traditionally done with the use of boards that equal the desired loose mat depth. Then a given amount of nose up attitude is introduced to the screed. The procedure is as follows:

- 1) The boards needed should be equal to the thickness of the loose or unrolled mat. The number needed will depend on the width the screed is set up to pave at. Generally 2 boards at 10' wide, 4 boards at 20' and est. The length of each board should be such that the screed bottom is fully supported from front to tail when set on the boards.

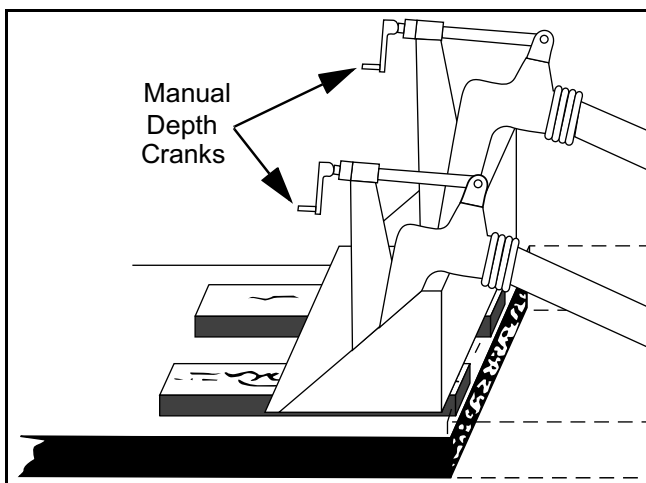

Figure 4 - 19 Nulling the Screed

- 2) Place the boards under the screed as illustrated. Attention should be placed on the grade conditions where the boards will be placed. If a board is placed on a high point or a depression, a false null setting will occur. Additional boards may be needed if you are paving at extended widths to provide support for the screed extensions. (Figure 4 - 19)
- 3) Place the screed lift switch in LOWER position. The screed will lower down and rest on the boards.
- 4) Turn both manual depth cranks on the screed until the screed face is resting flat on the boards. When the screed is resting flat on the boards the hand cranks will have a small area of free rotary movement where little resistance is felt. This indicates a null position.
- 5) After the screed has been nulled, we need to introduce a nose up attitude (initial angle of attack) on the screed. The amount of initial angle of attack is dependent on material design, temperature of material, head of material, tow point position and type of screed. Refer to these subjects for more information. Generally, the amount of initial angle of attack required will be 1 to 2 turns of clockwise rotation on the hand cranks. As paving begins, check the depth of the mat being placed and correct for as necessary. As most contractors work with a limited number of mix designs, the paver crews quickly learn the exact amount of initial angle of attack needed for specific mix designs.

Preparing to Pave

Joints

There are two types of joints that are constructed in a paving operation, Longitudinal and Transverse. Proper construction of these joints is important not only in producing a smooth rideable surface but also in how they resist penetration of water, air and other substances that would cause a premature failure of the joint. (Figure 4 - 20)

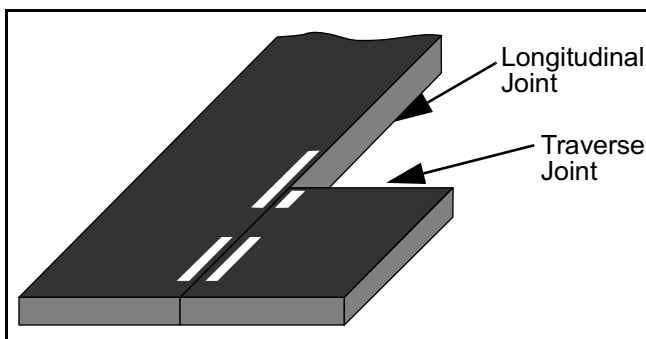

Figure 4 - 20 Types of Joints

Transverse Joints

Transverse joints are created when an existing mat or lane is to be continued. The quality and durability of the joint depends on careful preparation of the existing mat or lane. It is critical that any taper or defective area be removed.

Important - The joint area has to be perfectly flat and parallel with the line of paving. If it is not, a depression or bump will be produced.

Joint Preparation

The following illustration shows, how an existing mat is checked and the tapered area removed to produce a joint area that is flat and parallel with the line of paving. (Figure 4 - 21)

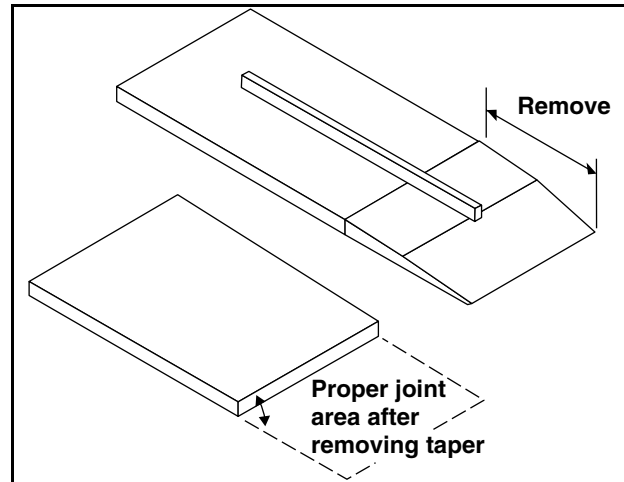

Figure 4 - 21 Joint Preparation

Joint Construction

The next step to proper joint construction is placing boards or lath that equal the amount of compaction in the joint area. Remember compaction rates change due to thickness of material & material design. Once the compaction rate has been determined and the correct thickness of lath has been acquired, place the lath at the edge of the joint to elevate & support the screed to the correct starting level.

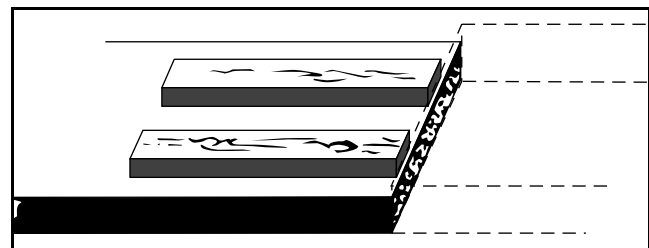

Figure 4 - 22 Matching existing mat

The screed should be preheated to the temperature of the material being used. A cold screed will not only tear the surface of the mat being placed but will also have a tendency to come off the joint low,

Preparing to Pave

creating a depression in the mat. Do not over heat the screed bottom, as this will damage or warp the screed bottom.

Back the paver up over the joint and align the screed so the face or mold board is square with the edge of the joint. Lower the screed onto the boards or lath and null the screed. Perform Nulling screed procedure on page 10

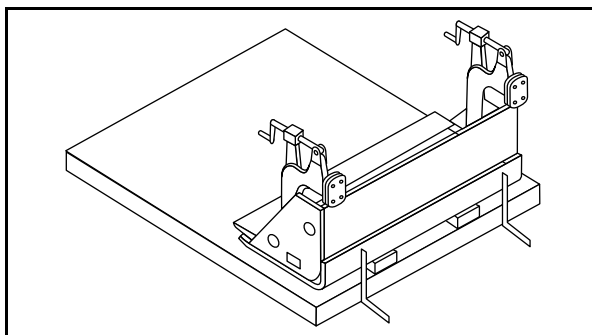

Figure 4 - 23 Aligning screed over joint

Once the screed has been nulled and the initial angle of attack has been introduced, the auger chamber should be filled to no more than 1/2 an auger level. Do not over fill the auger chamber, as this is the most common cause of creating a bump just after pulling off a joint. If needed the corner areas on the ends of the screed should be hand filled to prevent force feeding an excessive high head of material in the center areas of the screed.

After filling the auger chamber to the correct level, move the paver forward slowly, allowing the screed operator time to check and correct the depth if necessary. The feeder controls should be set to auto, and feed sensors checked and set to maintain the correct head of material. Once the paver has moved away from the joint area, the joint can be checked and prepared for rolling. The excess or over lap material must be removed, as this material can not be compacted into a cold or existing mat. Do not shovel this over lap material back onto the

fresh mat as this extra material may not be compacted down to the same height as the rest of the joint. This could create a bump.

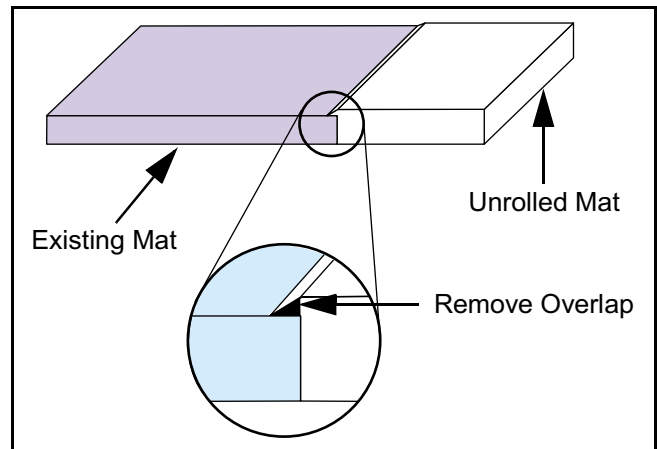

Figure 4 - 24 Removing overlap material before rolling

Once the over lap material has been removed, the joint should be checked with a good straight edge to ensure the thickness of the new mat is correct. If the new mat does not have enough material thickness at the joint when it is rolled, the density in the area where the new mat joins to the old mat will be low. This could cause a premature joint failure. If there is too much material in the joint area a bump will be produced.

Rubber Track Operating Hints

Rubber Track Operating Hints

The following are some specific considerations for operation of asphalt pavers equipped with rubber tracks. While not all-inclusive, following these recommendations should reduce the risk of problems and improve rubber track durability and reliability.

Do Not Allow Asphalt Build-up on Track

During paving, asphalt sometimes flows down to the rear drive wheel and become packed between the track and wheel. This may cause the following problems:

- Oil in the asphalt will cause the rubber in the track to soften and reduce the durability.
- Aggregate will abrade the rubber in the track and shorten its life.
- Asphalt material build-up in the undercarriage will cause additional tension on the track.

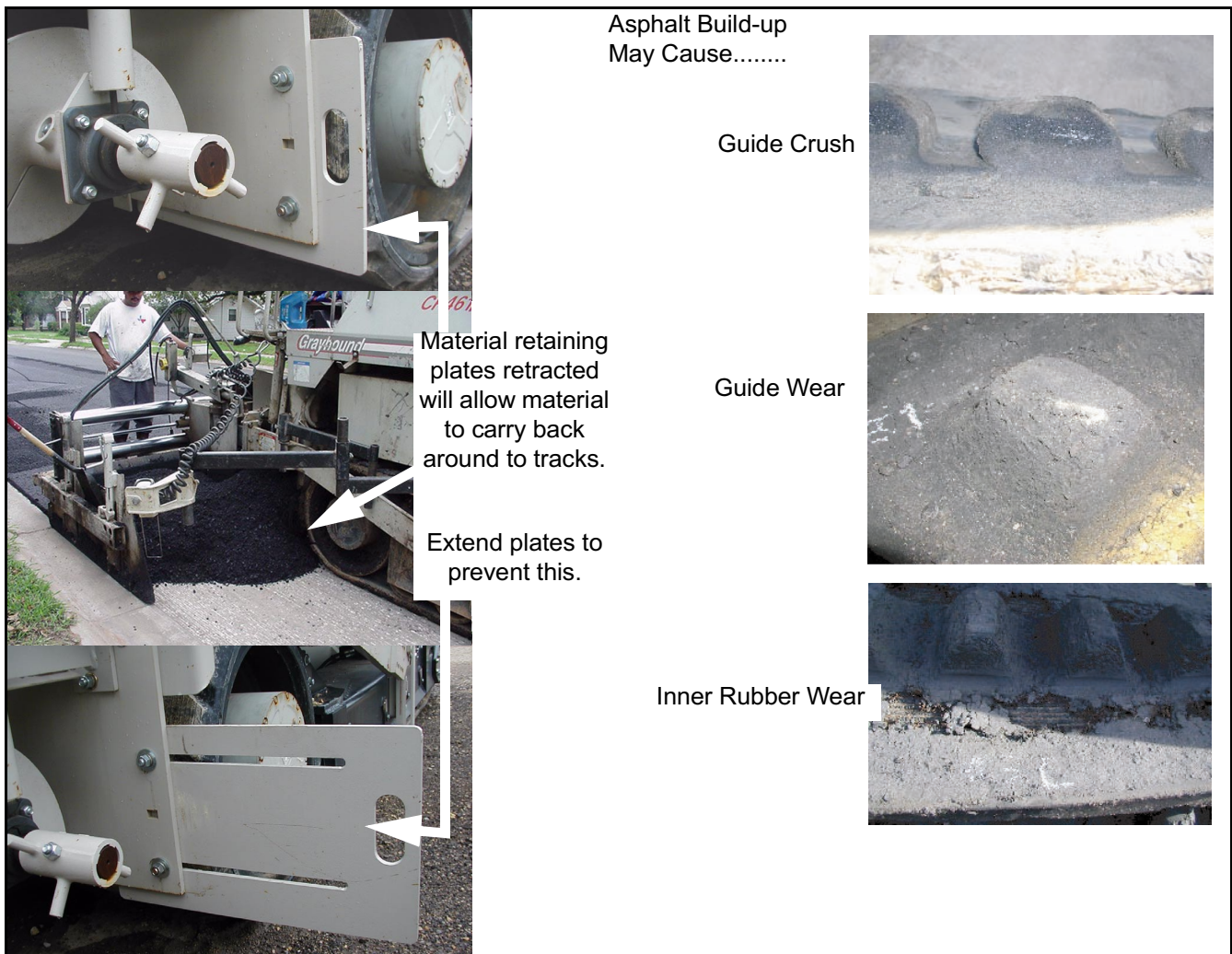

Figure 4 - 25 Asphalt on Track & Wear

Rubber Track Operating Hints

Proper Installation of Material Retaining Plates

Machines are shipped with the material retaining plates as shown in (Figure 4 - 26). To work properly, the plates must have the bottom edge of the plate below the bottom edge of the machine frame bulkhead and be extended.

Before paving begins, loosen nuts, slide plate out from frame and re-tighten nuts to hold plate in position. (Figure 4 - 27)



Figure 4 - 26

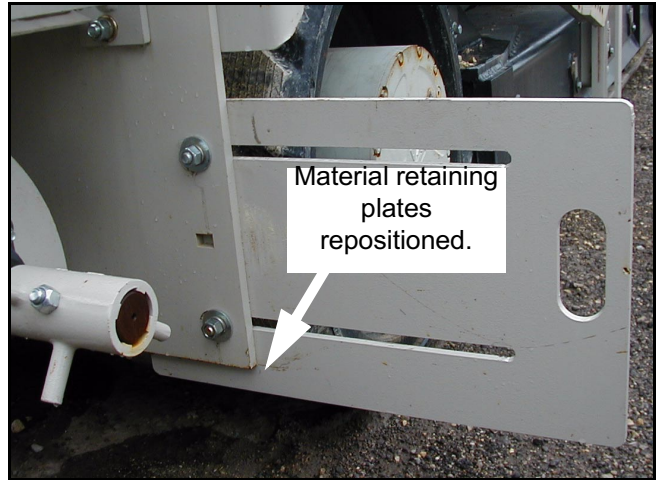

Figure 4 - 27

Rubber Track Operating Hints

Maneuvering On Hot Asphalt

Pavers are not normally operated on newly paved hot asphalt as it will damage the surface of the mat. There may however be certain conditions when this becomes unavoidable. If it is necessary to drive on newly paved asphalt, be aware this could be problematic.



Figure 4 - 28 De-tracking

Rubber Track Operating Hints

Generally, “de-tracking” occurs when the paver turns. If rubbing marks are noted on track frame, check track inner surfaces for signs of scarring caused by temporary de-tracking. To avoid “de-tracking”, it is recommended:

- **Do not turn on or near hot asphalt.** Move to a cold area and turn there. If turning on the hot asphalt is necessary, use forward as much as permissible and keep the turn gradual in as large an arc as possible. Maneuvering should be done at as slow a speed as possible.
- **Do not park on hot asphalt.** High temperature can deteriorate the track rubber. It is recommended to remain on the hot area of asphalt **no longer than twenty (20) minutes.**

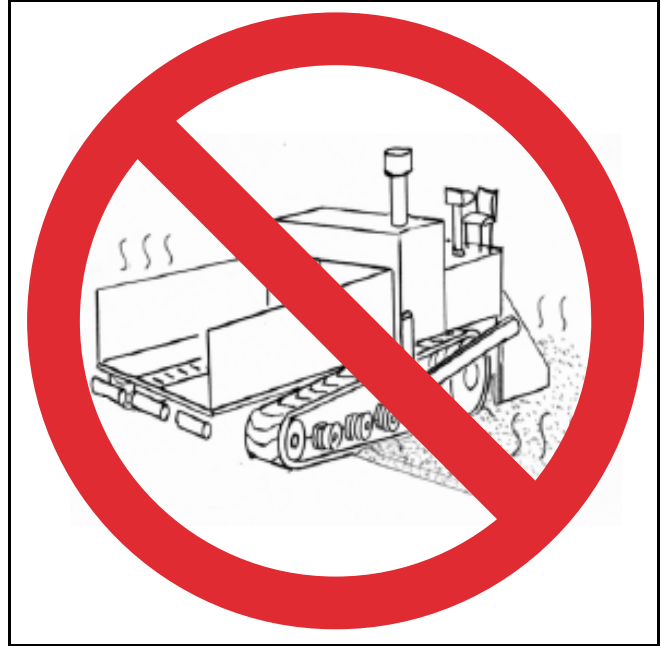

Figure 4 - 29 Do Not Park On Hot Asphalt

Rubber Track Operating Hints

Maneuvering On Uneven Surface

Uneven terrain such as curbs, concrete ridges or joints of paved and unpaved surfaces (step in elevation) may affect machine maneuverability. One concern is the stress concentration caused by the sharp edges of the surface and another is when a track is parallel to an edge. (Figure 4 - 30)



Caution - If a turn is attempted on an edge, track damage or “de-tracking” could occur.

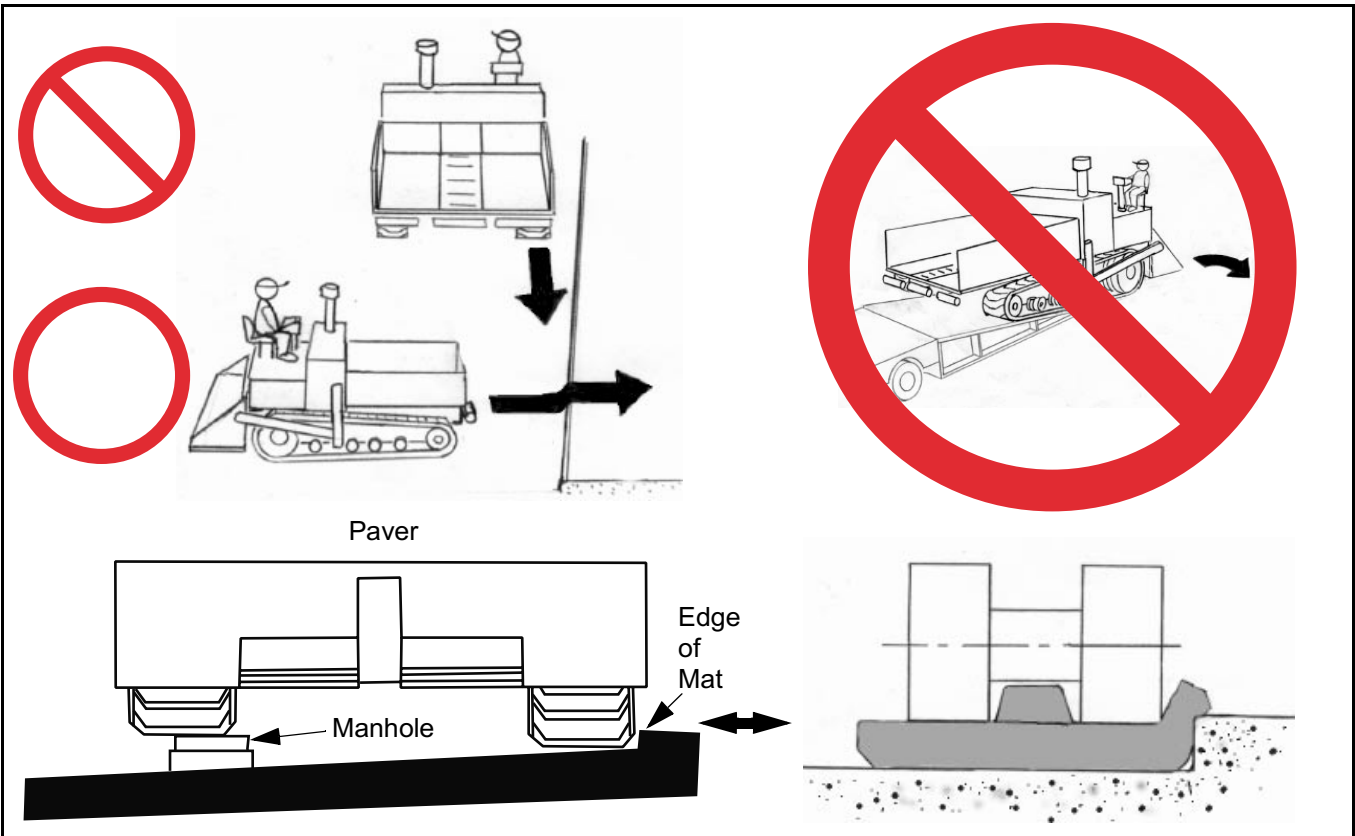

Figure 4 - 30 Steps in Elevation & Uneven Surfaces

- **Do not turn on or near sharp edges of uneven surfaces.** It is best to make a turn while on an even surface. If a turn is made with a portion of the track on an edge or the track comes into contact with an edge during the turn, it could cause a cut, tear, or even “de-tracking”. If this situation is unavoidable, keep the turn gradual in as large an arc as possible, at slow speed, in forward and with a spotter to watch the track safety.
- **Do not approach a step in elevation at a sharp angle.** If it is necessary to move from one level of elevation to another, it is recommended the approach angle should be more than 45 degrees. The best method is to go perpendicular to it.
- **Do not park on a step in elevation.** When parking, make sure the tracks are not resting on an edge or any sharp object. This may cause damage to the track.

Rubber Track Operating Hints

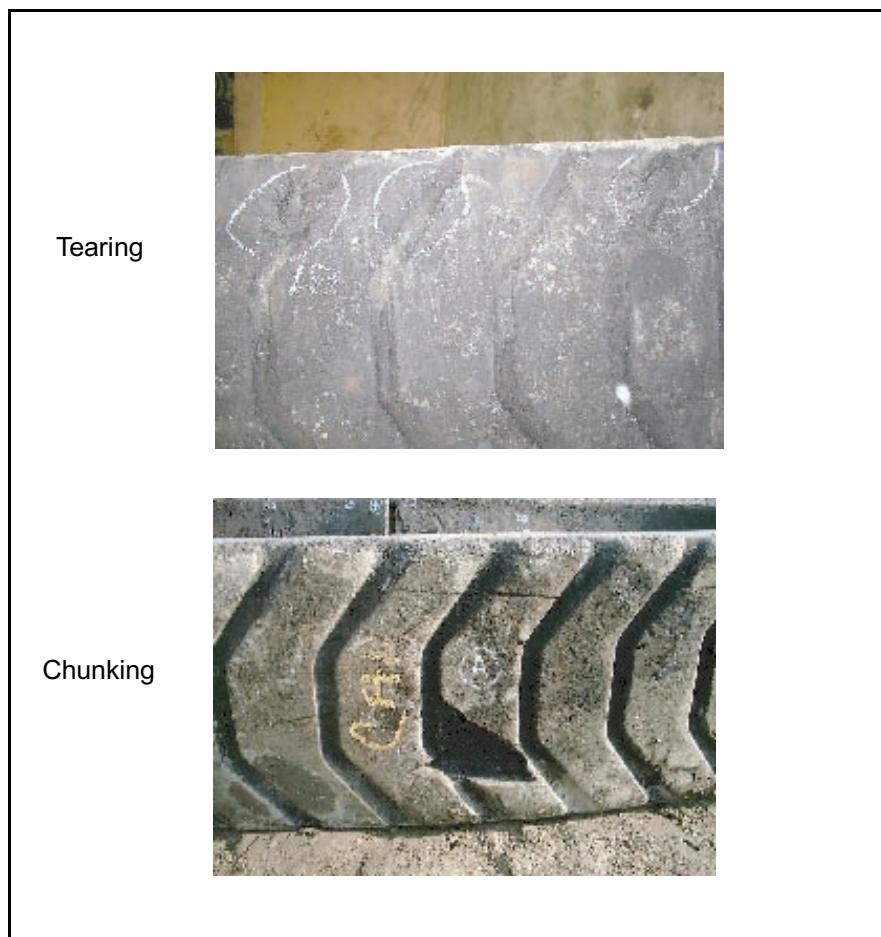

Figure 4 - 31 Damage From Steps in Elevation & Uneven Surfaces

Rubber Track Operating Hints

Maintenance of Track

To maintain and preserve the life of the rubber track it is important to follow these recommendations:

- **Do not use solvents to wash the rubber track.** Solvents including kerosene, gasoline, diesel fuel, or oils cannot be used to wash the surface of track rubber. The track rubber absorbs these solvents and will gradually soften and reduce its durability. Soap and water are recommended for cleaning the rubber track.

NOTICE

If you scrape the rubber track surface to clean it, be careful to not damage or cut it when cleaning.

- **Covering track for long term outdoor storage.** Rubber is affected by exposure to sunlight (ozone). Covering the track with something like a vinyl sheet if the machine is idle for an extended length of time, such as over Winter, will help keep the surface in good condition. This is especially true where the rubber is bent and stretched around wheels.

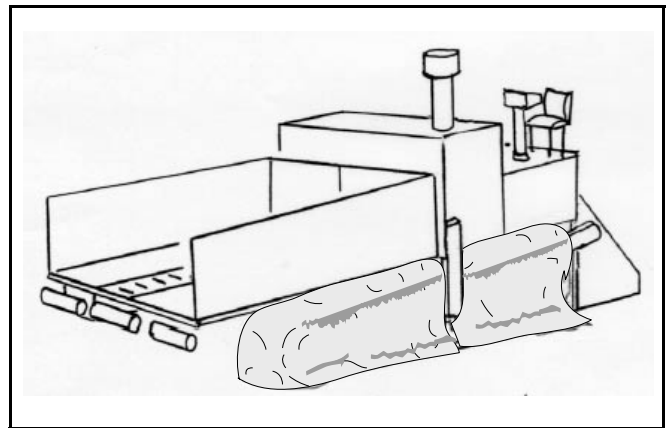

Figure 4 - 32 Cover Track for Outdoor Storage

Rubber Track Operating Hints

- **Releasing track tension for long term storage.** As is true for covering the track, releasing the track tension when the machine is idle for an extended length of time, such as over Winter, will prolong its life.

NOTICE

Before releasing track tension, make sure machine is parked on level ground.

Release 300 Series Rubber Track Tension

- 1) Shut off engine and remove key from ignition.
- 2) Loosen jam nut on track tension valve discharge cartridge (Figure 4 - 33).
- 3) Insert an allen wrench into the adjusting screw, slowly turn it counter-clockwise to open the shut-off valve and release hydraulic pressure.

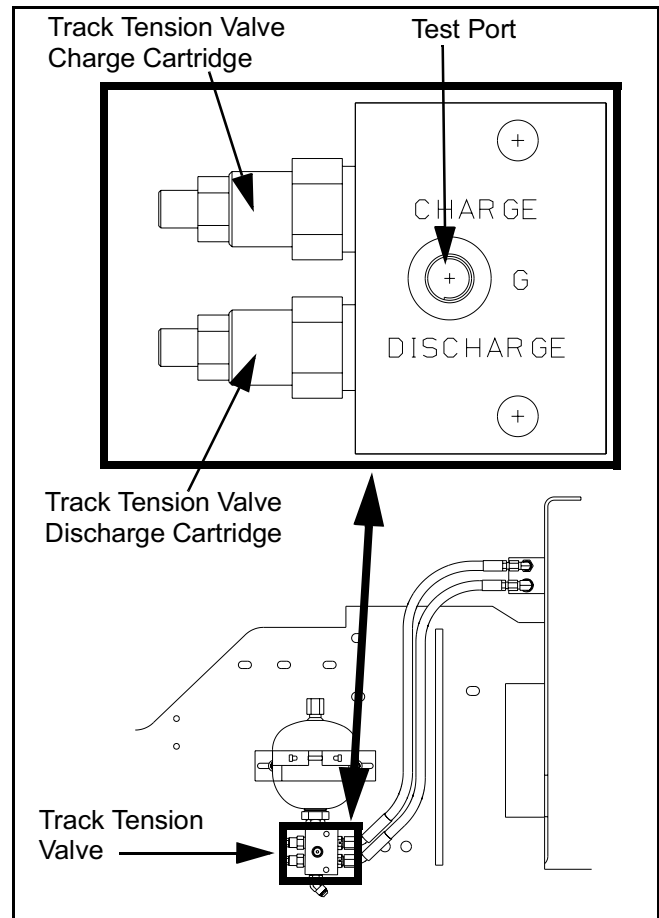

Figure 4 - 33 Release 300 Series Rubber Track Tension

- 4) Insert an allen wrench into the adjusting screw on the discharge valve cartridge and slowly turn it clockwise to close the valve.
- 5) Tighten jam nut on track tension valve discharge cartridge (Figure 4 - 34).
- 6) Repeat for the other track.

The 300 series pavers will require tracks to be re-tensioned after removal from long term storage. This is not done automatically, see procedure in Section 6.

Rubber Track Operating Hints

Release 400 & 500 Series Rubber Track Tension

- 1) Shut off engine and remove key from ignition.
- 2) Loosen jam nut on tension release valve cartridge (Figure 4 - 34).
- 3) Insert an allen wrench into the adjusting screw, slowly turn it counter-clockwise to open the valve and release hydraulic pressure.

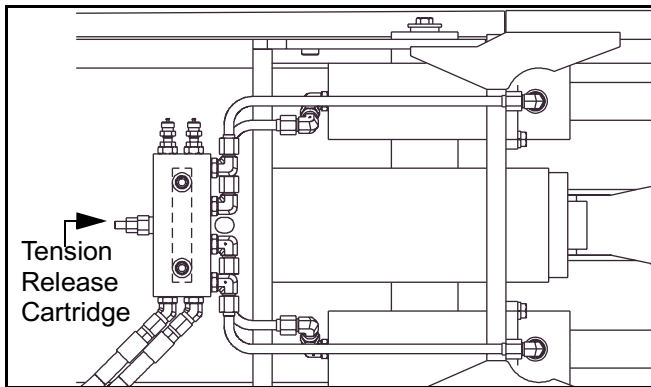

Figure 4 - 34 Release 400 & 500 Series Rubber Track Tension

- 4) Insert an allen wrench into the adjusting screw and turn it clockwise to close the valve.
- 5) Tighten jam nut on tension release valve cartridge (Figure 4 - 34).
- 6) Repeat for the other track.

The 400 and 500 series pavers will require the tracks to be re-tensioned after removal from long term storage. They are automatically tensioned when the engine is started. See procedure in Section 6.

Rubber Track Operating Hints

- **Check track alignment.** Rubber track undercarriage component alignment is very important to the life of the track. An easy, quick check is to inspect the track center lugs. (Figure 4 - 35) If one side is worn more than the other side, one or more of the following conditions could exist. Factors such as asphalt build-up on the track inner surface, road crown, track tensioning, etc. If any of the above is present, correct the situation before excessive track wear occurs.

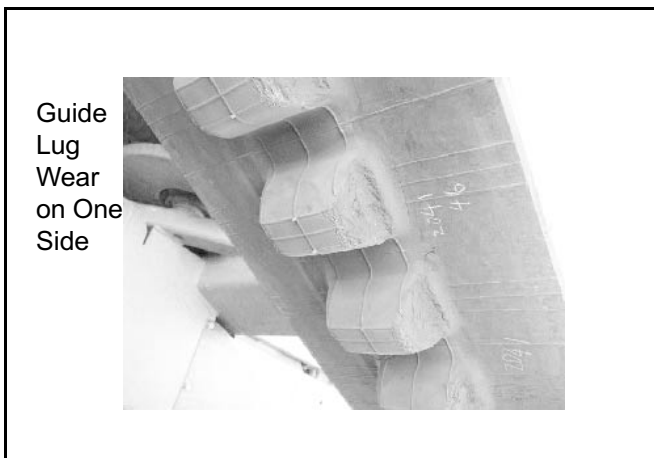

Figure 4 - 35 Rubber Track Alignment

- **Visual Inspection.** Unlike pneumatic tires, the rubber track is not as sensitive to chippings and cracks on the surface unless they extend to the separation of rubber from belt. The rubber track is not a 100% maintenance free product. The following items will be helpful to maintain and inspect your rubber tracks:

- 1) Record track serial numbers.
- 2) Record the date and hour meter reading when you mount tracks on machine.
- 3) Periodically check condition of tread, guide lugs, and inner surface for wear, cracks, chipping and chunking.

- 4) Periodically check that any steel cable or ply cord are not exposed.
- 5) Periodically check that track is properly tensioned. A loose track could cause de-tracking. (Refer to Tension information in the Operation and Maintenance Manual.

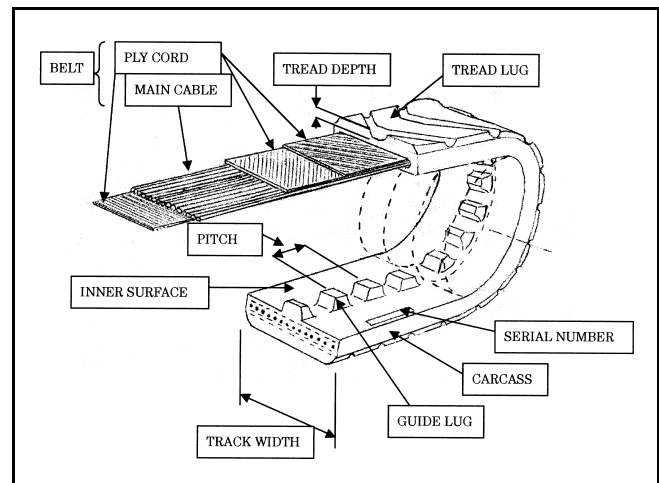

Figure 4 - 36 Rubber Track Identification

You may use the following table to record the information off the tracks on your machine.

Data	Right	Left
Machine Serial Number		
Hour Meter Reading		
Date of Track 1st Use		
Track Width		
Number of Pitches		
Pitch	6 inches	6 inches
Track Serial Number		

Table 4 - 2 Rubber Track Data

Spray Down and Cleaning

Spray Down and Cleaning

Paver Cleaning Procedure

Cleaning the paver is extremely important to keep the chains and augers free and prevent build-up of asphalt. Clean the paver thoroughly each day or any time the paver will be stopped for an extended period of time.

Notice: Hot mix gets hard quickly. Do not allow mix to cool in the hopper. Run remix augers to remove all material from the hopper any time the paver will be stopped for an extended period of time.



Warning: Use only environmentally safe solvents to clean paver.



Warning: Do not spray solvent in the presence of open flame, sparks, welding arcs, etc. A serious fire or explosion could result.

Notice: Keep solvent spray away from all electrical components, rubber parts and engine compartment. Do not spray the paver when it is parked on the mat. Move it to the side of the road for drainage of solvent and dissolved mix. Avoid spraying rubber hoses, cables, tires and/or rubber tracks with solvent as this may cause premature deterioration.

- 1) Run remix augers until all mix is out of the hopper. Remove any piles or large chunks of mix from the paver and screed.

- 2) Clean all parts which come in contact with hot mix. The paver must be completely cleaned even if the paver was used for a short time.
- 3) Start cleaning at the truck hook/push rollers and work your way to the rear of the machine cleaning the hopper wings, remix augers, hopper gates, spreading augers, screed bottom, end gates, strike-offs, etc. (Figure 4 - 37)

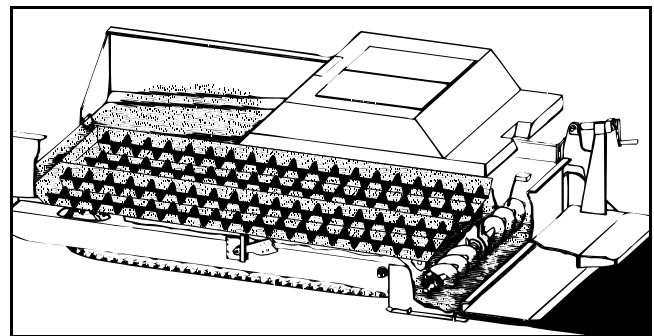

Figure 4 - 37 Shaded areas to be sprayed down daily

- 4) Operate remix augers during spray down to be sure all surfaces are cleaned.
- 5) Remove fume recovery system auger access hoods. Spray down surfaces that have come in contact with asphalt. Refer to Section 3 for information on when and how to clean fume recovery system fan and/or tubes.

Spray Down and Cleaning

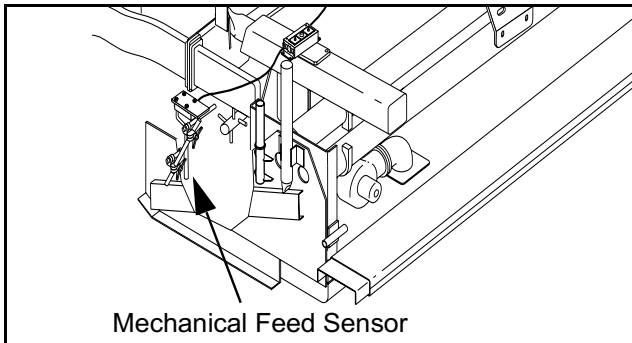

Figure 4 - 38 Mechanical feed sensor

- 6) If a mechanical feed sensor is used, clean the wand with solvent and wipe any asphalt off of the feed controller with a cloth dampened with solvent. (Figure 4 - 38)
- 7) Every time the paver is cleaned, the track should be cleaned and sprayed with light oil to lubricate the track pins to prevent them from rusting and binding.

Generation III Sonic Sensor Cleaning

- 1) Inspect the sensor daily for damage and material buildup. The sensor must be kept clean in order for the sonic control to function properly. The sensor is easily cleaned and if cleaned routinely, problems can be minimized.
- 2) Before cleaning, turn off power to the sonic control. Disconnect sensor cable from control unit and remove sensor from its mount. Install protective caps on all electrical connectors.

Notice: Using a sharp or solid object to scrape material from transducer could damage the sensor. If the transducer becomes damaged it will require

replacement of the complete sensor. The sensor is permanently sealed and can not be repaired.

- 3) Check transducer daily for material buildup. The transducer can be cleaned with Simple Green cleaning fluid. Place cleaning fluid on a clean rag and rub transducer gently to remove any material. Wipe transducer clean and dry (Figure 4 - 39).

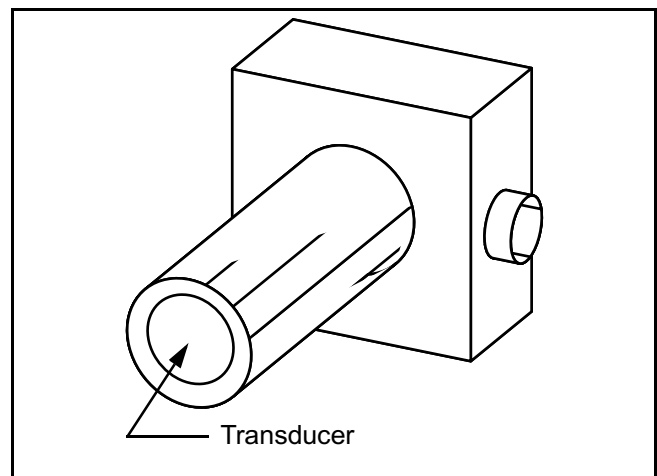

Figure 4 - 39 Cleaning sonic sensor

Pressure Cleaning

The entire paver can be pressure washed to remove dirt and grease. When pressure washing the paver:

- 1) Do not use a steam cleaner. Steam cleaning can damage seals, bearings, gearboxes, and electrical components.
- 2) Do not use an acid based solvent with the pressure washer. Use only mild detergents or degreasers.

Spray Down and Cleaning

- 3) Do not spray directly at electrical components, seals, bearings, gearboxes, or hydraulic cylinder rods. Water can be forced into electrical connections or the hydraulic system which could damage the system.
- 4) Do not spray the screed or engine until it is cool. Spraying a hot screed bottom with cold water could warp the screed bottom. Spraying cold water on a hot engine manifold could crack the manifold.
- 5) Use extreme caution when spraying in the engine compartment. The engine compartment is full of electrical and hydraulic components which could be damaged by high pressure water. Use a commercial engine cleaning foam to remove dirt and grease from the engine compartment.
- 6) If you must spray near electrical or hydraulic components, cover the components before spraying.



Spray Down and Cleaning

Section 5 - Hydraulic System

General Description

There are eight separate hydraulic circuits in the Grayhound remix paver (Figure 5 - 1). Two circuits drive the travel motors (one circuit for each side). Two circuits drive the delivery augers (one circuit for each side). Two circuits drive the spreading augers (one circuit for each side). One circuit supplies hydraulic power to all auxiliary functions such as hopper wings, truck hook, tow point cylinders, and tow arm cylinders. One circuit supplies hydraulic power for the fume recovery fan, screed vibrators and remote oil cooler fan motor. On newer units, hydraulic fluid discharged from the remote oil cooler fan circuit provides supercharged fluid to the auxiliary pump.

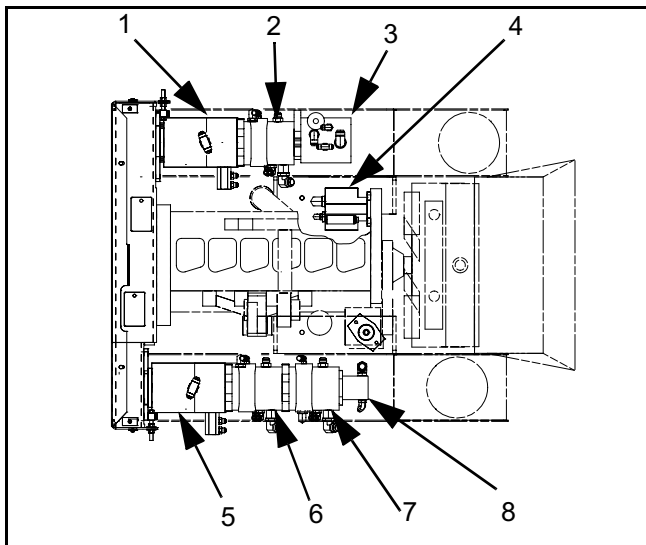

- | | |
|------------------------|-------------------------|
| 1 - Left Delivery Pump | 5 - Right Delivery Pump |
| 2 - Left Travel Pump | 6 - Right Travel Pump |
| 3 - Left Spreader Pump | 7 - Right Spreader Pump |
| 4 - Auxiliary Pump | 8 - Vibrator Pump |

Figure 5 - 1 Hydraulic Pumps

Each circuit has its own pump to develop system pressure and its own motor or cylinder to convert hydraulic pressure and flow into mechanical

movement. Two reservoirs hold hydraulic fluid for all systems and one cooler maintains an operable fluid temperature.

Fluid Temperature

Excessively hot hydraulic fluid is an indicator of trouble developing in the hydraulic system. An operator should make it a habit to check the hydraulic oil temperature reading periodically throughout the day, just as he does the engine oil pressure, coolant temperature, voltage, etc. Normal operating range is 120° to 160°F. Any time the hydraulic fluid temperature approaches or exceeds 180°F, stop paving and determine the cause. Refer to Hydraulic System Troubleshooting in the Paver Technical Manual.

Fluid Reservoirs:

Two fluid reservoirs which serve all hydraulic systems are located beneath the hood on the right- and left-hand side of the paver. These reservoirs are interconnected so they both maintain the same fluid level. Reservoir fluid capacity is 47 gallons.

A baffle divides the inlet side of each reservoir from the outlet side. This baffle reduces oil foaming and air suspended in the oil which can damage the pumps. A breather is located on the top of each reservoir to release pressure that builds up as the oil heats up and cools down. These breathers should be kept clean to allow air to flow through the breather. A drain hose is connected to each reservoir to make changing the hydraulic oil convenient. The hose are mounted to the rear bulkhead on each side of the paver. When draining the reservoirs, both reservoir hoses should be drained at the same time to remove as much of the old oil as possible.

Delivery Auger Pumps

Each delivery auger pump drives two counter-rotating remix deliver augers. Each pump is made up of a variable displacement axial piston main pump and a charge pump. The charge pump draws oil from the reservoir and outputs the oil at 350 PSI minimum. The oil is filtered and routed into the intake of the main pump. The main pump supplies 5000 PSI maximum pressure directly to the two delivery auger motors. If the pressure goes over 5000 PSI the pump is destroyed to reduce the flow rate and maintain the 5000 PSI pressure setting.

Delivery Auger Drive Systems

The delivery auger drive system permits infinitely variable speed adjustment. Delivery auger speed is varied in two ways. First, the speed of the delivery augers in AUTOMATIC can be adjusted proportionally to the speed of the spreading augers by adjusting the Remix Ratio control knobs on the operator console. Second, the delivery augers in MANUAL can be controlled independently from the spreading augers.

Pump displacement is controlled by the Electric Displacement Control (EDC). As the demand for more hot mix at the spreading augers increases, the EDC on the deliver auger pump proportionally increases the angle of the pump swashplate. The increased swashplate angle increases the length of travel for the pumps pistons which in turn increases the speed of the deliver auger motors.

High Pressure Adjustment



Warning: To perform this procedure safely requires two people. One person will make the adjustments and the other person will need to be at the control panel at all times.

Delivery Auger Pumps

The multi-function valve has two functions. 1) It determines the high pressure setting. 2) It allows the oil to bypass the pump. This second function is not used on remix pavers.

Each delivery auger pump has two multi-function valves. One for forward, and the other for reverse.

The pressure limiter and high pressure relief valve pressure setting are both adjusted by the multi-function valve. To set the high pressure limit:

- 1) Disconnect the high pressure line at the bulkhead fitting and plug the line. (Figure 5 - 2)

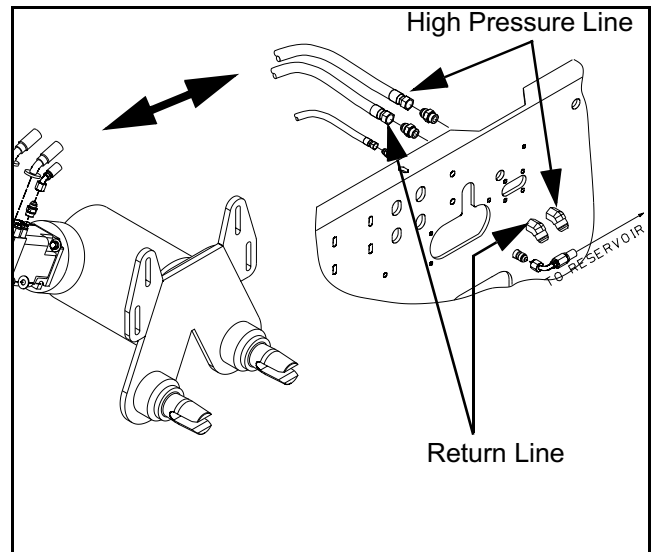

Figure 5 - 2 Plug High Pressure Line

- 2) Install two 10,000 PSI pressure gauges in the high pressure gauge ports. (Figure 5 - 3)

Delivery Auger Pumps

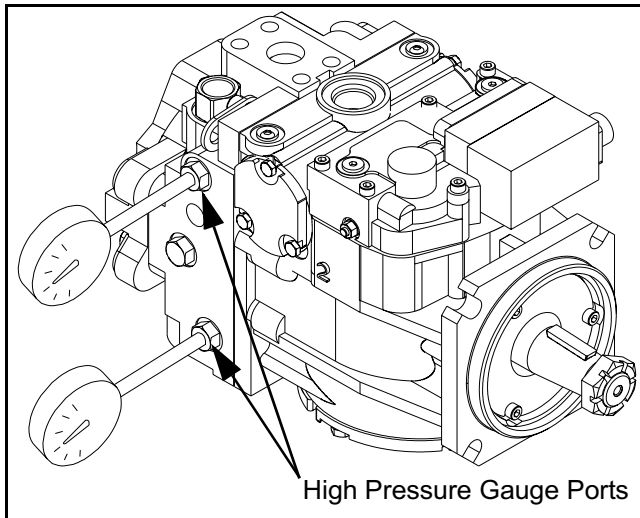

Figure 5 - 3 Install Pressure Gauges

- 3) Start the engine and run at full throttle.
- 4) Loosen locking nut (smallest hex on multi-function valve) on one of the pressure adjustments. (Figure 5 - 4)

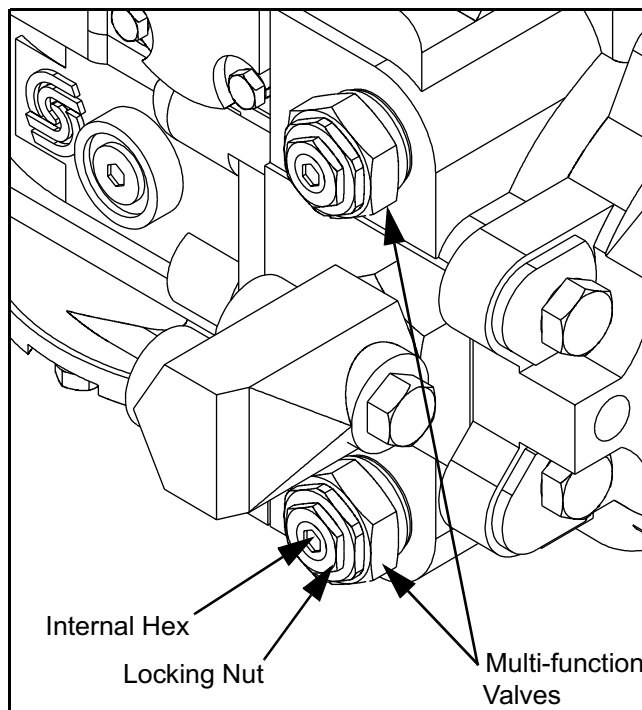

Figure 5 - 4 Multi-function Valve Adjustments

- 5) Insert an internal hex wrench into the pressure adjusting screw.
- 6) Move the Feed Conveyor Override switch on the operator console to the **OVERRIDE** position. The pressure readings on one of the pressure gauges should rise and remain steady when it reaches the pressure limiter setting.
- 7) Rotate the pressure adjusting screw with the internal hex wrench, until a 5000 PSI reading is reached on the pressure gauge.

Important: Clockwise rotation of the pressure adjustment screw will increase the pressure setting, counterclockwise rotation will decrease the pressure setting. Each complete rotation of the pressure adjusting screw changes the pressure setting by 1350 PSI.

- 8) While holding the internal hex wrench and pressure adjusting screw in the same position, tighten the pressure adjusting screw lock nut to 12 in. lbs. Do not over-torque.
- 9) Release the Feed Conveyor Override switch on the operator console. The pressure in the high pressure circuit should return to the charge pressure setting. To verify the actual pressure setting, move the Feed Conveyor Override switch to **OVERRIDE** while watching the pressure gauge. The pressure should return to the 5000 PSI setting.
- 10) Return the Feed Conveyor Override switch to **STOP** and shut off the engine.

Travel Pumps

Travel Pumps

Each travel motor is driven by a separate pump. Each travel pump is made up of a variable displacement main pump and a charge pump. The charge pump draws oil from the reservoir and outputs the oil at 295 PSI minimum. The oil is filtered and routed into the intake of the main pump. The main pump supplies 5550 PSI maximum pressure directly to the traction motor. If the pressure goes over 5550 PSI the relief valves open and bypass fluid to the reservoirs.

Travel Drive Systems

The travel drive system permits infinitely variable speed adjustment from zero to maximum with torque available for any normal paving load. The speed will be maintained within the governed allowance whether the paver is pushing a loaded truck uphill or emptying the hopper. There will be no acceleration downhill even when hooked to a loaded truck.

Each travel drive motor is supplied by its own pump, providing independent control of each track/wheel. The fluid output of the travel drive pumps can be reversed so the paver can move either forward or backward without mechanical gear shifting.

To move forward the operator places the Travel Direction Switch or Travel Lever in the forward(F) position and slowly rotates the Speed Dial clockwise. As the Speed Dial is rotated the Electric Displacement Control (EDC) on the travel pump proportionally increases the angle of the swashplate. The increased swashplate angle increases the length of travel for the pumps pistons which in turn increases the speed of the travel motor.

Checking System Relief Setting

The pressure relief valves for travel pumps are factory set and should bypass fluid at 5550 +/- 200 psi. The relief valve settings should not be tampered with, except for replacing the entire valve. If load reaches this limit, fluid is bypassed around hydraulic motor and drive motor will stall. The factory setting is adequate for any paving condition. Therefore in the event of a stall, cause of overload should be determined and eliminated.

Should a relief valve emit a high-pitched squeal, operator should quickly determine the cause. Continued operation will result in component damage and operating problems.

To test the high pressure relief setting:

- 1) Stop engine and remove Master key.
- 2) Engage the paver brakes.
- 3) Turn Paver Speed Dial to lowest setting. Position Travel Lever/Switch to Neutral position.
- 4) Install pressure gauges to the high pressure ports on travel pump. (Figure 5 - 5)

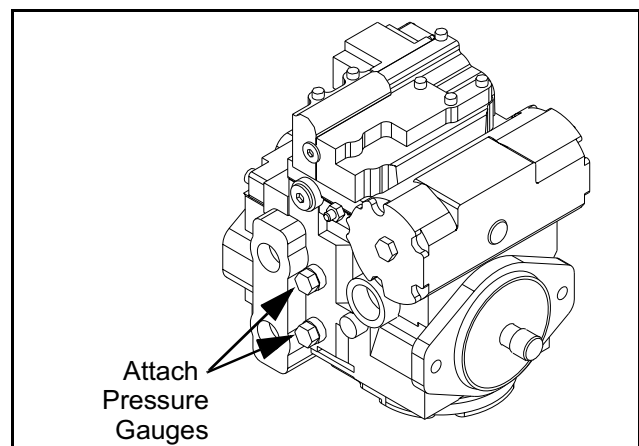

Figure 5 - 5 High Pressure Test Ports

Travel Pumps

- 5) Start engine and run at full throttle.

Notice: Do not run the pressure over relief any longer than it takes to read the gauge.

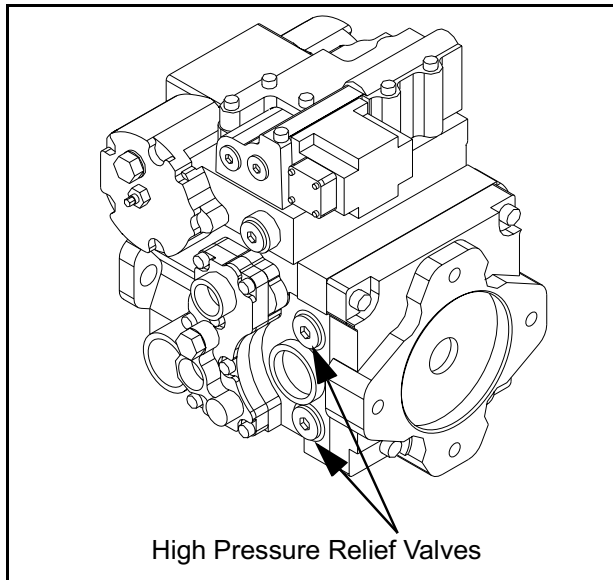

Figure 5 - 6 High Pressure Relief Valves

- 6) The pressure gauges should read 0 psi. Move the Travel Lever/Switch on the operators console to the Forward direction. Slowly increase the speed setting on the Speed Dial. The pressure readings on the pressure gauges should rise slowly and remain steady when it reaches the relief setting. If the pressure reading does not change, move the Travel Lever/Switch on the operators console to the reverse direction and repeat this step. If the pressure is significantly higher or lower than 5550 psi, the pressure relief valve is defective and must be replaced. (Figure 5 - 6)

Notice: The relief valves are factory set and should not be tampered with except for replacing the entire cartage. Disassembly may change the setting and cause erratic unit operation or premature failure.

System High Pressure Relief Valve Replacement

The high pressure relief valve may be removed for cleaning and installation of fresh O-rings. (Figure 5 - 7)

- 1) Remove the valve seat plugs from the pump housing.

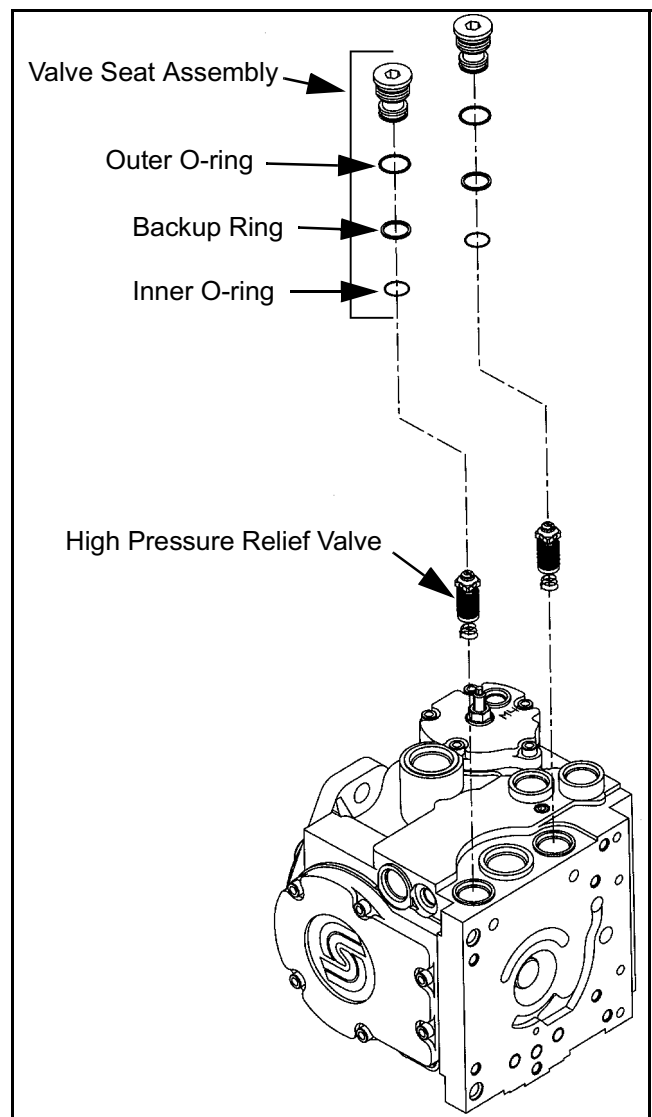

Figure 5 - 7 Relief Valve Replacement

Travel Pumps

- 2) Remove relief valve assembly from pump housing. The smaller end of each conical spring is crimped to retain it on the relief valve. Do not remove.
- 3) Inspect the valves and mating seats in the special plugs for damage or foreign material.
- 4) Install a new outer O-ring, new backup ring, and new inner O-ring on each valve seat plug.
- 5) Check that the conical springs are properly retained on the relief valves. Install the high pressure relief valve assemblies into the pump housing.

Notice - The conical springs **MUST** be correctly positioned on the relief valves after installation for proper pump operation.

- 6) Install the valve seat plugs into the pump housing and torque 40-95 Nm (30-70 ft-lb).

Travel Neutral Adjustment

Should the tractor “creep” when the Travel Switch/ Lever is in the Neutral position, the pump neutral setting must be readjusted. These are factory set and normally will not need adjustment. If neutral adjustment becomes necessary, perform the following procedure. Refer to the following figures during this procedure.

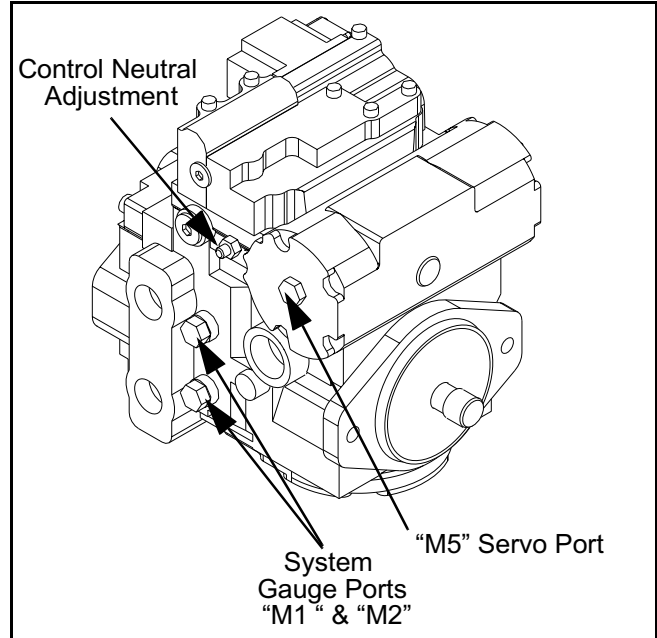

Figure 5 - 8 Traction Pump Ports

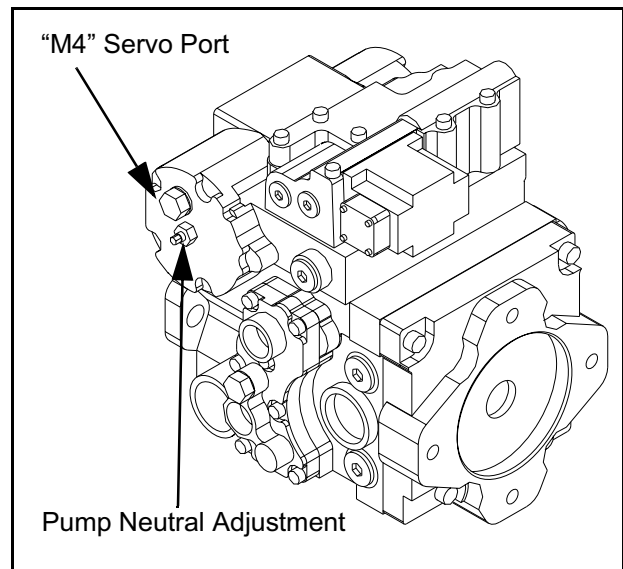

Figure 5 - 9 Traction Pump Ports

- 1) Engage the Brake switch on the operator console.

Travel Pumps

- 2) Install a low pressure line (500 psi min.) connecting port “M4” and port “M5”. This removes the effects of any control pressure on the servo piston.
- 3) Install pressure gauges (10,000 psi) in the system pressure gauge ports “M1” & “M2”. Start the engine and run at full throttle.
- 4) Loosen the 17mm hex pump neutral adjustment seal lock nut while holding the pump neutral adjustment screw in position. Turn the 7mm hex pump neutral adjustment screw until the two system pressure gauge readings are equal.
- 5) Rotate the pump neutral adjusting screw clockwise until one of the system pressures starts increasing. Note the position “A” of the hex wrench. Rotate the pump neutral adjusting screw counter-clockwise until the other system pressure increases in the other gauge. Note the position “B” of the internal hex wrench. (Figure 5 - 10)

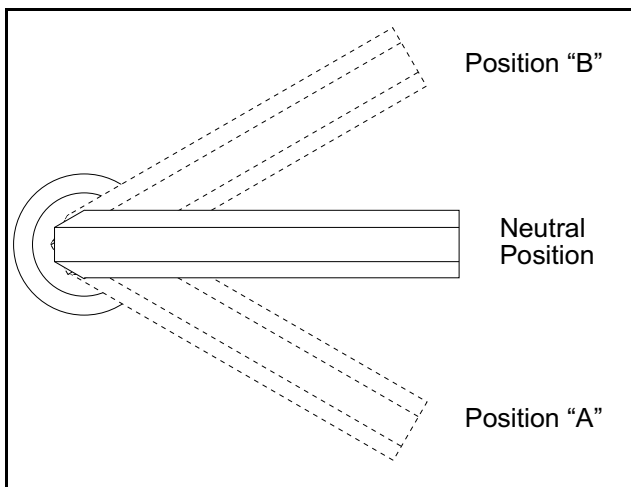

Figure 5 - 10 Pump Neutral Position

- 6) Rotate the pump neutral adjusting screw clockwise half the distance between positions “A” & “B”. The control should now be in a neutral position. In this position the gauges should read the same pressure (case pressure.)
- 7) While holding the pump neutral adjustment screw from turning, torque the pump lock nut 21 to 37 ft. lbs. Stop the engine.

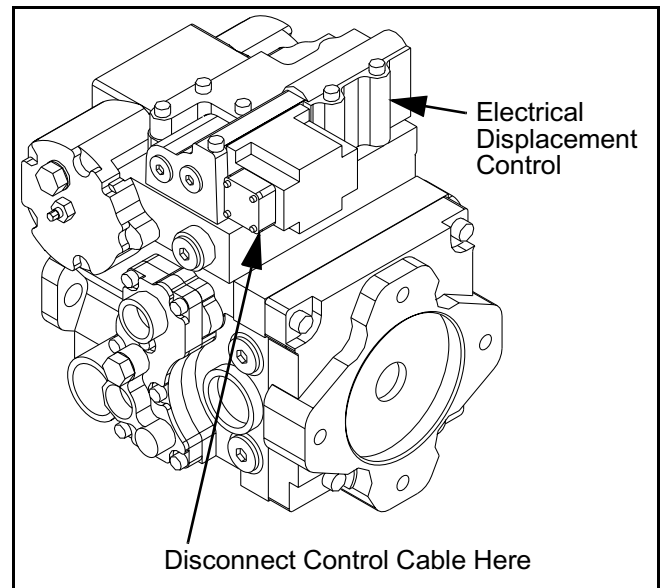

Figure 5 - 11 Electrical Displacement Control

- 8) Disconnect the Electrical Displacement Control at the pump controller. (Figure 5 - 11)
- 8) Start the engine and run at full throttle.
- 9) Loosen control neutral adjustment lock nut with 17mm wrench and slowly rotate the control neutral adjustment screw clockwise, with 5mm internal hex wrench, until the pressure is equal on both gages. (Figure 5 - 8)

Travel Pumps

- 10) Turn the control neutral adjustment screw clockwise until one of the system pressures starts to increase. Note the position “A” of the internal hex wrench. (Figure 5 - 10)
- 11) Without removing the internal hex wrench, rotate the control neutral adjusting screw counter-clockwise until the pressure increases in the other gauge. Note the position “B” of the internal hex wrench.
- 12) Rotate the control neutral adjusting screw clockwise half the distance between location “A” & “B”. The control should now be in a neutral position. In this position the gauges should read the same pressure (case pressure.) (Figure 5 - 10)
- 13) While holding the control neutral adjustment screw from turning, torque the lock nut 10 to 18 ft. lbs.
- 14) Stop the engine and connect the cable to the EDC. Remove all pressure gages.

Spreading Auger Pumps

Spreading Auger Pumps

Each spreading auger motor is driven by a separate pump. Each spreading auger pump is made up of a variable displacement main pump and a charge pump. The charge pump draws oil from the reservoir and outputs the oil at 205 PSI minimum. The oil is filtered and routed into the intake of the main pump. The main pump supplies 3330 PSI maximum pressure directly to the spreading auger motor. If the pressure goes over 3330 PSI the relief valves open and bypass fluid to the reservoirs.

Spreading Auger Drive Systems

The spreading auger drive system permits infinitely variable speed adjustment from zero to maximum. The feed control system constantly measures material pile height in front of the screed and adjusts the spreading auger speed to maintain a consistent level of material in front of the screed.

Pump displacement is controlled by the Electric Displacement Control (EDC). As the demand for more hot mix at the screed increases, the EDC on the deliver auger pump proportionally increases the angle of the pump swashplate. The increased swashplate angle increases the length of travel for the pumps pistons which in turn increases the speed of the deliver auger motors.

Checking System Relief Setting

The pressure relief valves for spreading auger pumps are factory set and should bypass fluid at 3330 +/- 200 psi. The relief valve settings should not be tampered with, except for replacing the entire valve. If load reaches this limit, fluid is bypassed around hydraulic motor and auger will stall. The factory setting is adequate for any paving condition. Therefore in the event of a stall, cause of overload should be determined and eliminated.

Should a relief valve emit a high-pitched squeal, operator should quickly determine the cause. Continued operation will result in component damage and operating problems.

To test the high pressure relief setting:

- 1) Stop engine and remove Master key.
- 2) Disconnect high pressure line to the spreading auger hydraulic motor and plug line. (Figure 5 - 12)

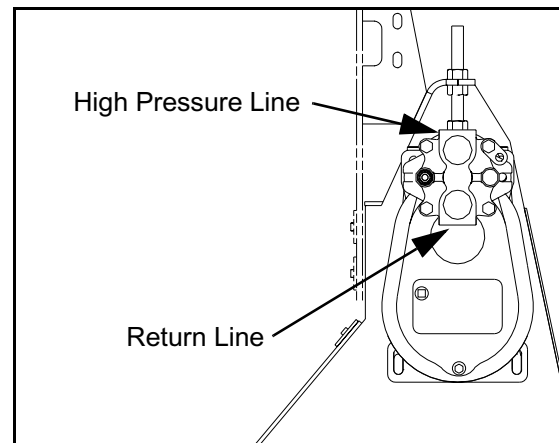

Figure 5 - 12 Spreading Auger Hydraulic Motor

- 3) Install pressure gauges to the high pressure ports on spreading auger pump. (Figure 5 - 13)

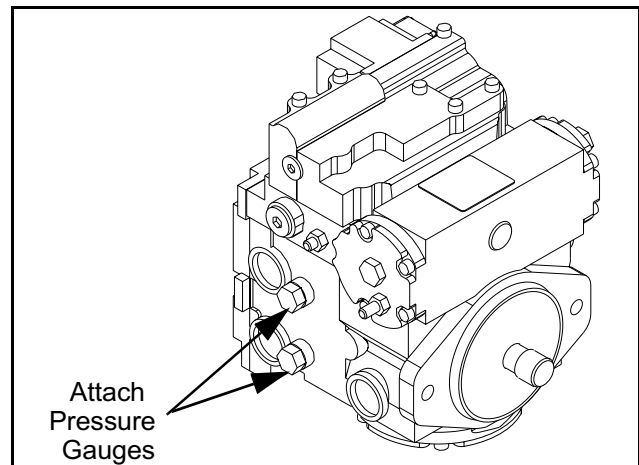

Figure 5 - 13 High Pressure Test Ports

Spreading Auger Pumps

- 4) Start engine and run at full throttle.

Notice: Do not run the pressure over relief any longer than it takes to read the gauge.

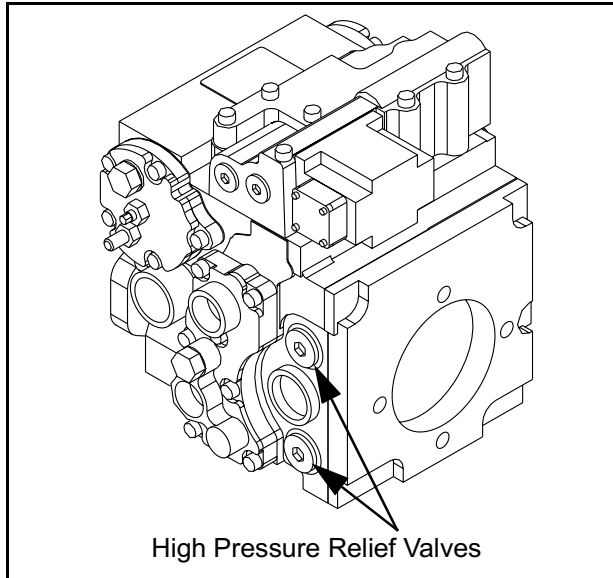

Figure 5 - 14 High Pressure Relief Valves

- 5) The pressure gauges should read 0 psi. Move the Feed Conveyor Override switch on the operator console to the OVERRIDE position. The pressure readings on one of the pressure gauges should rise and remain steady when it reaches the pressure limiter setting. If the pressure is significantly higher or lower than 3330 psi, the pressure relief valve is defective and must be replaced. (Figure 5 - 14)

Notice: The relief valves are factory set and should not be tampered with except for replacing the entire valve. Disassembly may change the setting and cause erratic unit operation or premature failure.

System High Pressure Relief Valve Replacement

The high pressure relief valve may be removed for cleaning and installation of fresh O-rings. (Figure 5 - 15)

- 1) Remove the valve seat plugs from the pump housing.

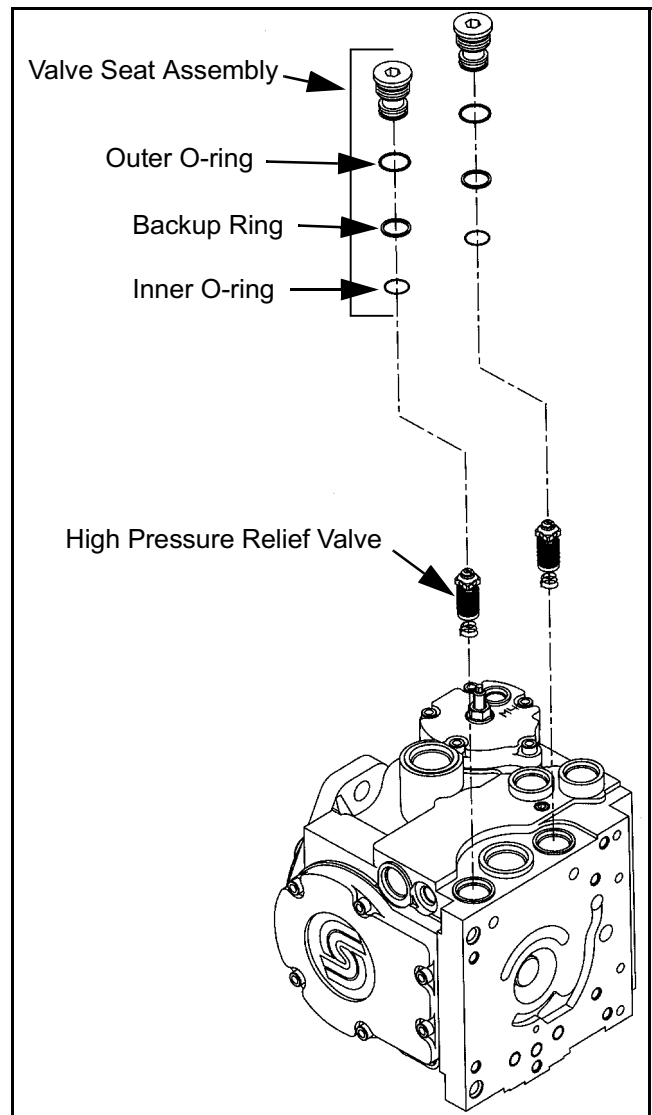

Figure 5 - 15 Relief Valve Replacement

Spreading Auger Pumps

- 2) Remove relief valve assembly from pump housing. The smaller end of each conical spring is crimped to retain it on the relief valve. Do not remove.
- 3) Inspect the valves and mating seats in the special plugs for damage or foreign material.
- 4) Install a new outer O-ring, new backup ring, and new inner O-ring on each valve seat plug.
- 5) Check that the conical springs are properly retained on the relief valves. Install the high pressure relief valve assemblies into the pump housing.

Notice - The conical springs **MUST** be correctly positioned on the relief valves after installation for proper pump operation.

- 6) Install the valve seat plugs into the pump housing and torque 40-95 Nm (30-70 ft-lb).

Spreading Auger Neutral Adjustment

Should the spreading augers “creep” when the Feed Conveyor Override switch is in the STOP position, the pump neutral setting must be readjusted. These are factory set and normally will not need adjustment. If neutral adjustment becomes necessary, perform the following procedure. Refer to the following figures during this procedure.

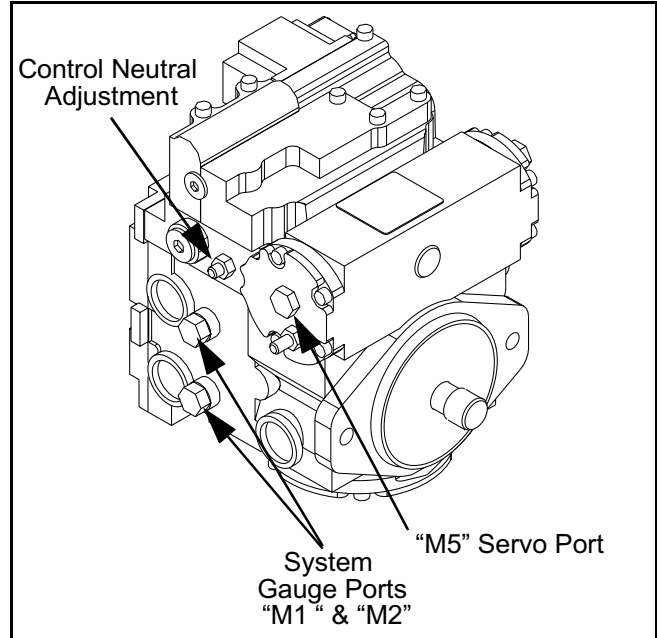

Figure 5 - 16 Spreading Auger Pump Ports

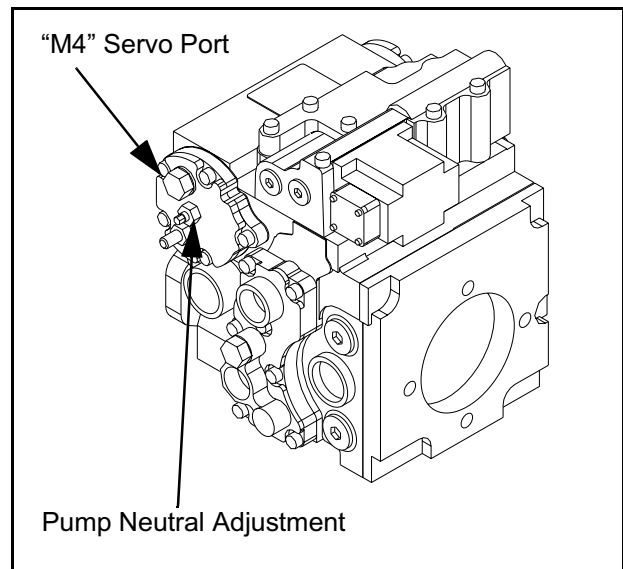

Figure 5 - 17 Spreading Auger Pump Ports

- 1) Disconnect high pressure line to the spreading auger hydraulic motor and plug line. (Figure 5 - 18)

Spreading Auger Pumps

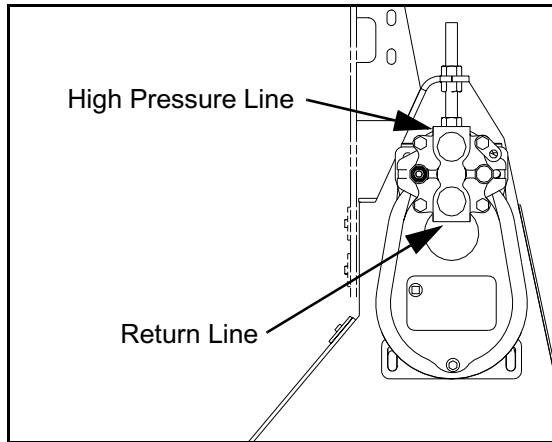

Figure 5 - 18 Spreading Auger Hydraulic Motor

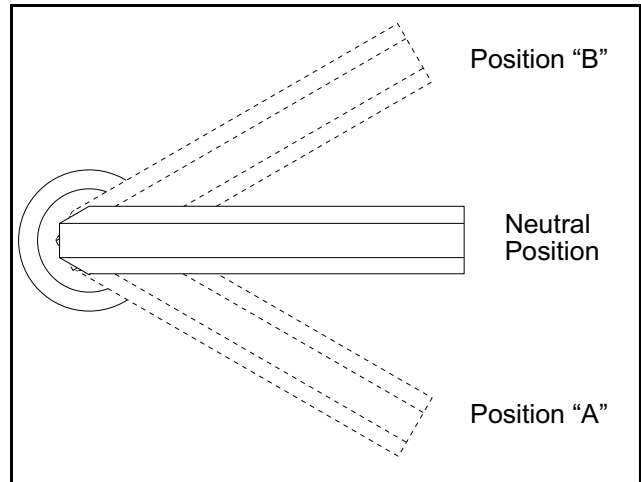

Figure 5 - 19 Pump Neutral Position

- 2) Install a low pressure line (500 psi min.) connecting port "M4" and port "M5". This removes the effects of any control pressure on the servo piston.
- 3) Install pressure gauges (10,000 psi) in the system pressure gauge ports "M1" & "M2". Start the engine and run at full throttle.
- 4) Loosen the 13mm hex pump neutral adjustment seal lock nut while holding the pump neutral adjustment screw in position. Turn the 5mm hex pump neutral adjustment screw until the two system pressure gauge readings are equal.
- 5) Rotate the pump neutral adjusting screw clockwise until one of the system pressures starts increasing. Note the position "A" of the hex wrench. Rotate the pump neutral adjusting screw counter-clockwise until the other system pressure increases in the other gauge. Note the position "B" of the internal hex wrench. (Figure 5 - 19)
- 6) Rotate the pump neutral adjusting screw clockwise half the distance between positions "A" & "B". The control should now be in a neutral position. In this position the gauges should read the same pressure (case pressure.)
- 7) While holding the pump neutral adjustment screw from turning, torque the pump lock nut 15 to 19 ft. lbs. Stop the engine.

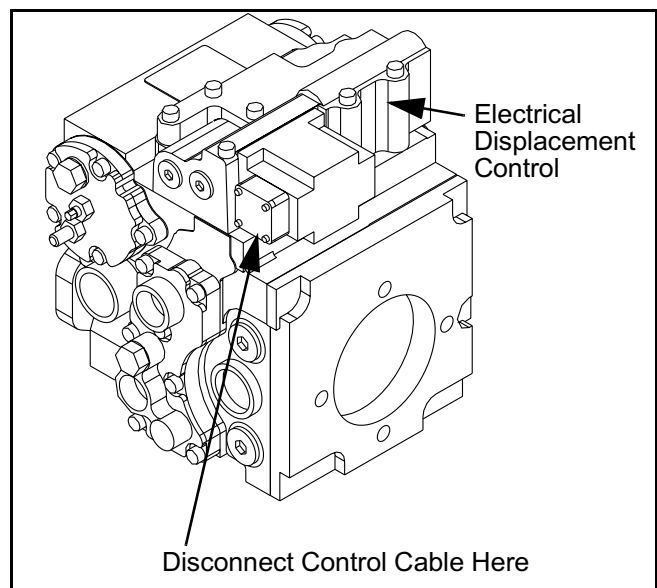

Figure 5 - 20 Electrical Displacement Control

Spreading Auger Pumps

- 8) Disconnect the Electrical Displacement Control at the pump controller. (Figure 5 - 20)
- 8) Start the engine and run at full throttle.
- 9) Loosen control neutral adjustment lock nut with 17mm wrench and slowly rotate the control neutral adjustment screw clockwise, with 5mm internal hex wrench, until the pressure is equal on both gages. (Figure 5 - 16)
- 10) Turn the control neutral adjustment screw clockwise until one of the system pressures starts to increase. Note the position “A” of the internal hex wrench. (Figure 5 - 19)
- 11) Without removing the internal hex wrench, rotate the control neutral adjusting screw counter-clockwise until the pressure increases in the other gauge. Note the position “B” of the internal hex wrench.
- 12) Rotate the control neutral adjusting screw clockwise half the distance between location “A” & “B”. The control should now be in a neutral position. In this position the gauges should read the same pressure (case pressure.) (Figure 5 - 19)
- 13) While holding the control neutral adjustment screw from turning, torque the lock nut 10 to 18 ft. lbs.
- 14) Stop the engine and connect the cable to the EDC. Remove all pressure gages.

Remix Delivery Control

Remix Delivery Control

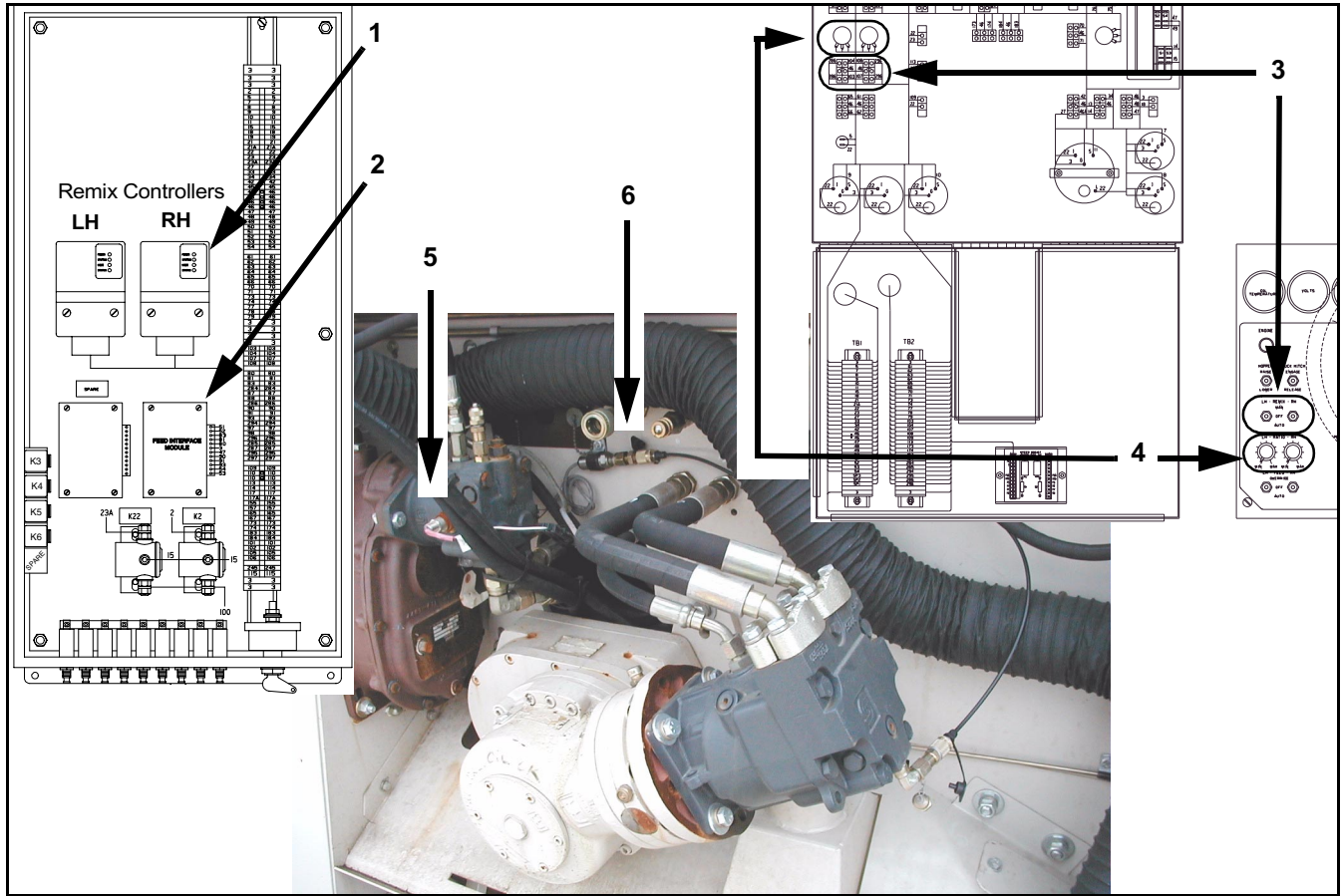

Figure 5 - 21 Remix Delivery Control Components

Delivery Control Components

- 1) Controller W/Ind. Lights: Programmed to process electrical signals coming from speed and pressure sensors and ratio pot, then output signals to delivery auger pump EDC. Indicator lights provide troubleshooting assistance.
- 2) Feed Interface Module: Provides a relay contact between controller output and spreading auger pump EDC coil. This relay pulls in via AUTO-OFF-MANUAL Switch.
- 3) AUTO-OFF-MANUAL Switch: Sends 12 VDC signal to controller to select mode of operation.
- 4) Ratio Pot: Sends 0.5 - 4.5 VDC signal to controller.
- 5) Speed Sensor: Located on spreading auger motor and provides pulse signal to controller to allow AUTO operation.
- 6) Pressure Sensor: Located on rear bulkhead in delivery auger motor pressure circuit and provides 0.5 - 4.5 VDC to controller indicating 0 to 10,000 PSI of hydraulic pressure.
 - a) 0.5 VDC @ 0 PSI
 - b) 2.5 VDC @ 5000 PSI
 - c) 4.5 VDC @ 10,000 PSI

Remix Delivery Control

Remix Delivery Control Operation

AUTO-OFF-MANUAL Switch in MANUAL

- 1) Ratio dial operates strictly as a speed control.
- 2) Operates whether spreading augers are ON or Off.
- 3) Pressure sensor on delivery auger motor is active and will limit horsepower when needed.

AUTO-OFF-MANUAL Switch in AUTO

- 1) Ratio dial setting determines the speed of the delivery augers in relation to the spreading auger speed. (0 - 100% of spreading auger speed range)
- 2) Delivery augers start and stop with the spreading augers no matter what mode the spreading augers are operating. (MANUAL, AUTO, or OVERRIDE)
- 3) Delivery auger speed is based on spreading auger speed and ratio setting.
- 4) Set ratio dial to maintain a uniform head of material (one half auger level).
- 5) Spreading auger RPM should remain constant with this setting.
- 6) Pressure sensor on delivery auger motor is active and will limit horsepower when needed.

Remix Delivery Control Troubleshooting

The delivery augers are controlled by the remix feed controllers mounted in the main electrical box. (Figure 5 - 21)

If replacement of a controller becomes necessary, simply remove the old one and plug in the new one. No adjustment is needed.

Refer to the electrical schematic supplied with your machine and the following information to assist in troubleshooting this system. Also, the chart below (Figure 5 - 22) gives a guide to reading the status of the indicator lights on the controllers.

- 1) Controller: Sensor power output wire 284 (LH) and 294 (RH) should have 5VDC. If low voltage, check for defective sensor, ratio pot, or grounded wiring.
- 2) Ratio Pot: Provides range of 0.5 to 4.5VDC to controller.
 - a) 0.5VDC at MIN
 - b) 2.5VDC at 50% dial setting
 - c) 4.5VDC at MAX
- 3) AUTO-OFF-MANUAL Switch: Provides 12VDC to controller to select mode of operation and supplies power to the controller eliminating need for feed interface module on valve output.
- 4) Speed Sensor: Located on spreading auger motor, provides pulse signal to controller to allow AUTO operation.
- 5) Pressure Sensor: Located on rear bulkhead in delivery auger motor pressure circuit, provides a range of 0.5 to 4.5VDC to controller.
 - a) 0.5VDC at 0 PSI
 - b) 0.7VDC at 500 PSI
 - c) 0.9VDC at 1000 PSI
 - d) 2.5VDC at 5000 PSI
 - e) 4.5VDC at 10,000 PSI

Remix Delivery Control

INDICATOR LIGHT	COLOR	LIGHT STATUS	ERROR CODE	ERROR DESCRIPTION
Power	Green	On Solid	N/A	Indicates Power to Controller
System	Green	On Solid	N/A	Indicates +5 VDC Out of Controller
Mode	Yellow	Blinking	1 Blink / 2 Seconds	Program is Running OK
Mode	Yellow	Blinking	10 Blinks / 1 Second	Controller Needs Replaced - (No Program Loaded)
Mode	Yellow	Not Blinking On or Off	Light Completely Off or On Solid	Program Not Running - Cycle Power Off and back On (If problem still exists, replace controller)
Status	Red	Blinking	1110	Pressure signal out of range (defective wiring or sensor)
Status	Red	Blinking	0100	Ratio Pot signal out of range (defective wiring or speed pot)
Status	Red	Blinking	0110	Spreading Auger not running or defective wiring or speed sensor
Status Indicator Light Code Legend: Short Blink = 0 Long Blink = 1				

Figure 5 - 22 Remix Controller Troubleshooting

Vibrator Pump

One fixed displacement gear pump is used in the paver to power the screed vibrators and remote oil cooler (ROC) fan. This pump provides up to 2800 PSI fluid to the remote oil cooler fan and 1500 PSI fluid to the vibrators at 2500 RPM. As engine speed is reduced, the pump output rate and pressure capability is reduced.

To check and adjust the remote oil cooler fan system pressure:

- 1) Disconnect and plug the high pressure line to remote oil cooler fan motor. (Figure 5 - 23)

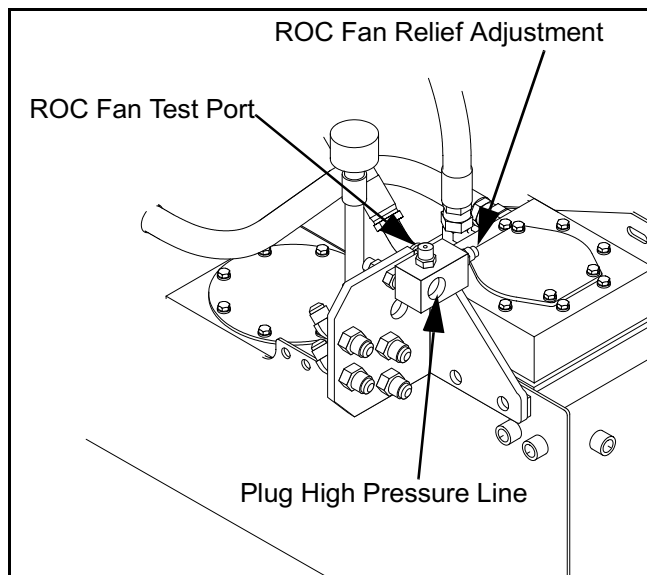

Figure 5 - 23 ROC Pressure Adjustment

- 2) Install a 3000 PSI gauge to the ROC fan test port.
- 3) Start the engine and run at full throttle.
- 4) If the pressure gauge does not read 2800 PSI +/- 100, loosen the ROC fan relief adjustment valve. Rotate the valve until pressure reads 2800 PSI. Tighten relief valve adjustment.

Vibrator Pump

- 5) Remove gauges and reconnect plumbing.

To check and adjust the vibrator system pressure:

- 1) Disconnect vibrator hoses at the rear bulkhead.
- 2) Install a 3000 PSI pressure gauge to the test port on the vibrator solenoid valve. (Figure 5 - 24)

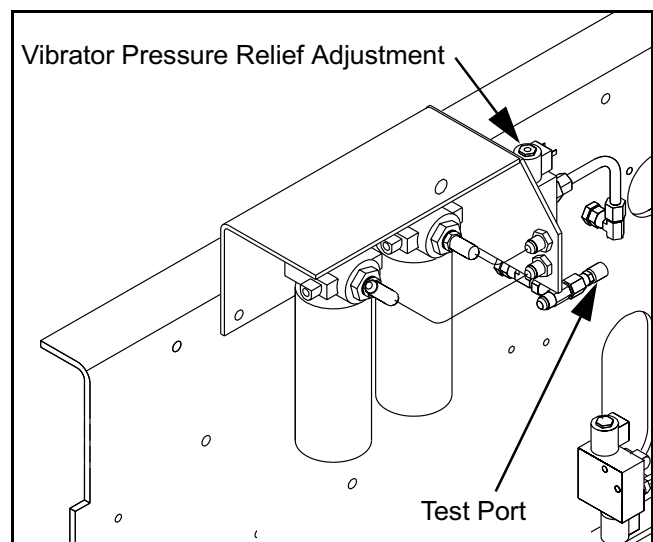

Figure 5 - 24 Vibrator Pressure Test Port

- 3) Start the engine and run at full throttle.
- 4) Release the paver's brakes.
- 5) Turn the vibrator switch ON, speed dial to zero, and the travel control forward.

Important: The vibrators do not engage until the travel control is in the forward position.

- 5) If the pressure gauge does not read 1500 PSI loosen the relief valve adjustment. Rotate the relief valve adjustment until the pressure reads 1500 PSI. Tighten the relief valve adjustment.

Auxiliary Systems Pump

Auxiliary System

The auxiliary system consists of a pressure-compensated variable-displacement pump to raise and lower the screed, hopper wings, pull points, frame raise, operate rubber track hydraulic system, and engage the truck hook.

Solenoid-operated selector valves are controlled by toggle switches from the operator's console or at the screed. When none of the above functions are being operated, the pump is destroyed to minimize fluid flow while maintaining 2500 psi pressure.

On newer pavers, the auxiliary pump is supplied with supercharged oil from the remote oil cooler drive pump.

Auxiliary System Pressure Compensator Check

The compensator for the auxiliary system should be set to bypass fluid at 2500 +/- 100 psi.

- 1) Install a pressure gauge (3000 psi) at the auxiliary pump filter test port. (Figure 5 - 25)

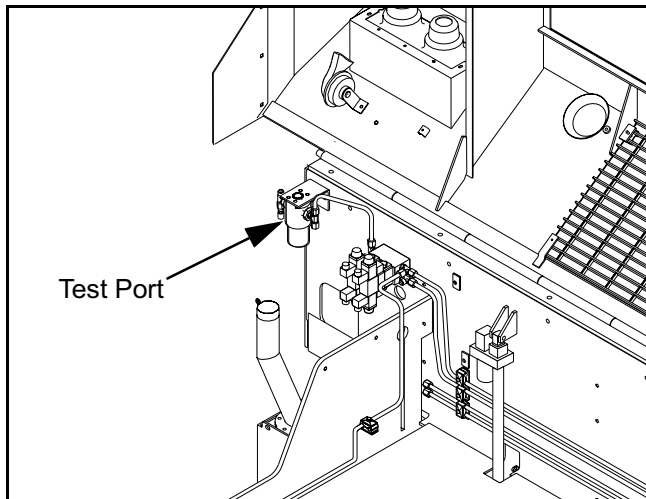

Figure 5 - 25 Auxiliary Pressure Test Port

Auxiliary Systems Pump

- 2) Start the engine and warm up the hydraulic oil. When the engine and oil are warm, move the throttle switch to full.
- 3) Observe the pressure gauge. The pump should maintain 2500 +/- 100 psi at full throttle.
- 4) If the pump will not maintain 2500 psi, rotate the compensator adjustment (Figure 5 - 26) clockwise to increase the pressure or counter-clockwise to reduce the pressure. If pressure cannot be attained, refer to Hot Mix Paver Technical Manual, Pumps-Motors-Drives section for more troubleshooting and repair information.

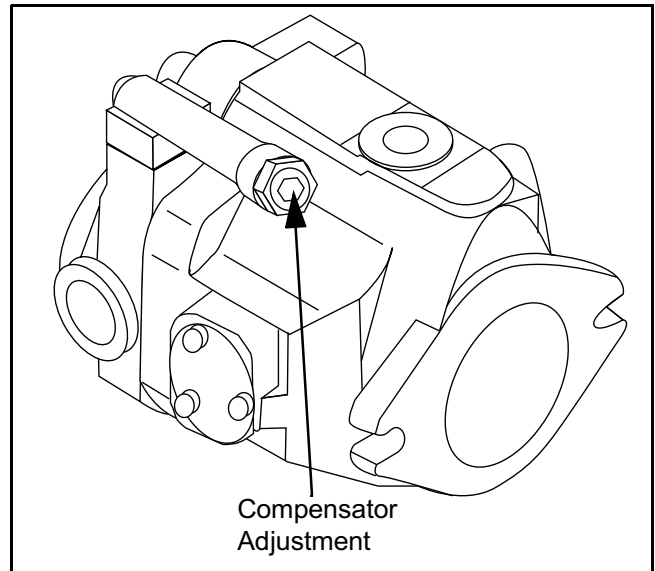

Figure 5 - 26 Auxiliary Pump

Note: When installing a new auxiliary pump, you must adjust the system pressure compensator to obtain the required 2500 psi. **New pumps do not come pre-set.**

Rubber Track Hydraulic System

Rubber Track Hydraulic System

The rubber track hydraulic system, see schematic (Figure 5 - 27) maintains a constant volume of pressurized oil to the piston ends of track tension cylinders. Each track is independent and supplied by the auxiliary pump.

When the paver is started, oil is directed from the auxiliary pump to the pressure reducing valves. Oil pressure is reduced from 2500 psi to 1900 psi and directed on to the take-up valves where two separate sections, a charging/isolation cartridge

and a direction sensing cartridge, route the oil to the track tension release valves connected to the track tensioning cylinders. A check valve and accumulator for each track are placed between the take-up valve charging/isolation cartridge and the piston side of the track tension release valve. The accumulator is pre-charged with dry nitrogen at 1800 psi to allow the track tensioning cylinders to retract and return if a severe impact is encountered.

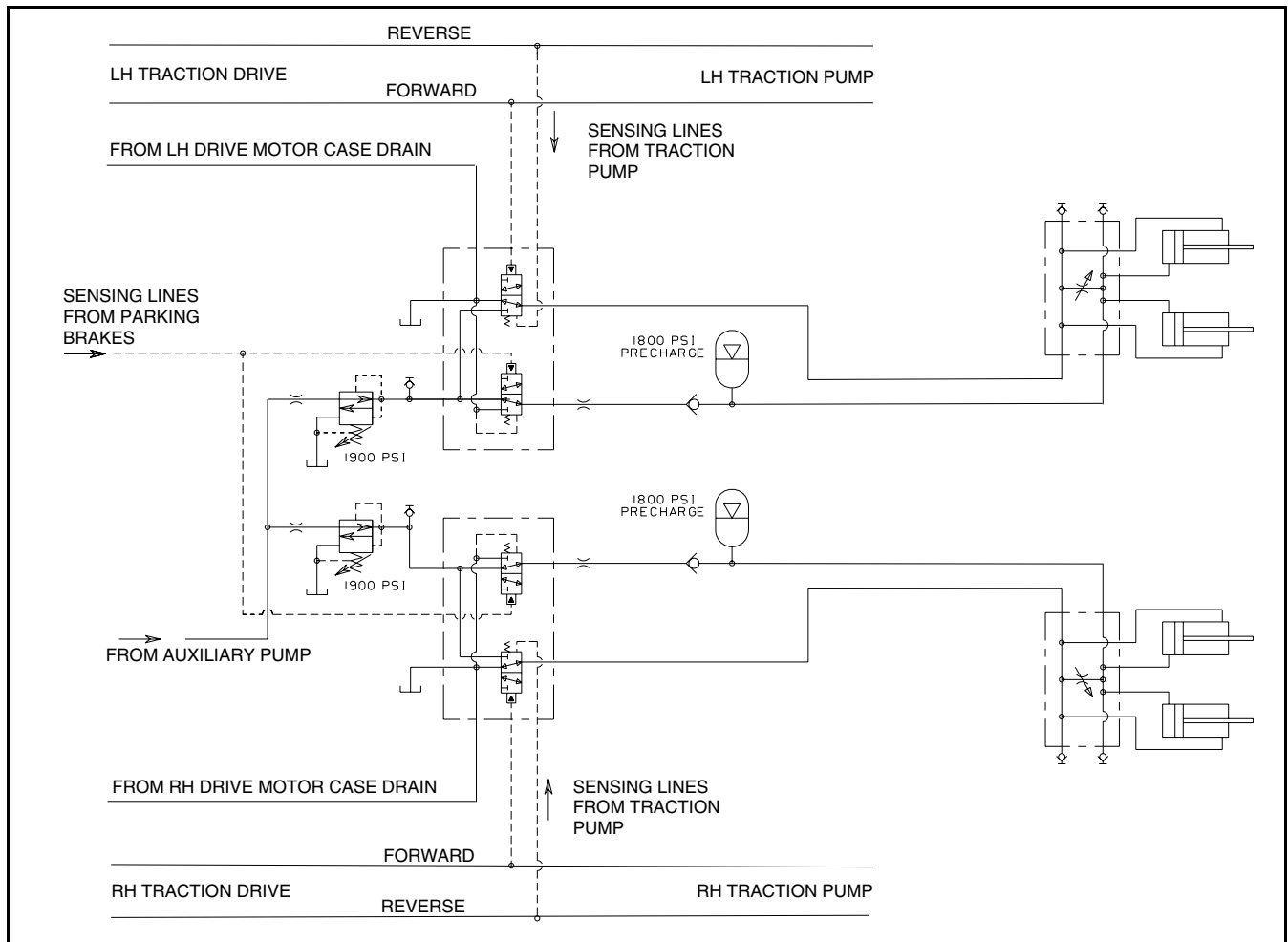

Figure 5 - 27 Rubber Track Hydraulic System Schematic - (Shown in Reverse)

Rubber Track Hydraulic System

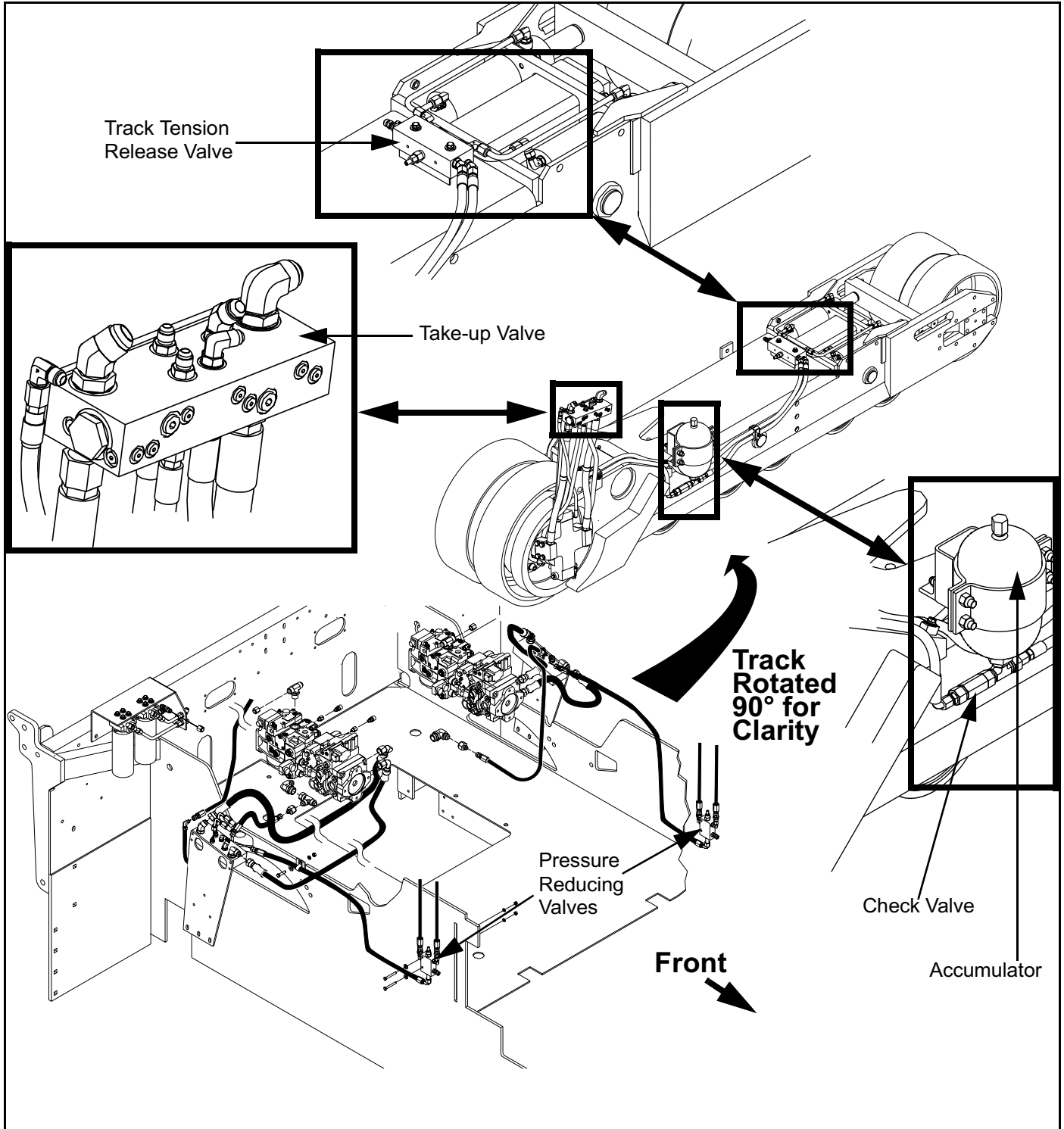

Figure 5 - 28 Rubber Track Hydraulic System Components

Rubber Track Hydraulic System

Checking Rubber Track Hydraulic System

The rubber track hydraulic system contains components which will automatically maintain track tension (Figure 5 - 28). To check out the system, follow the steps below:

Auxiliary System Pump Pressure

First check the auxiliary pump pressure compensator adjustment to be sure the system is set to 2500 +/- 100 psi. See Section 5, page 5-16 for this procedure.

Pressure Reducing Valves

Check the pressure reducing valves on each side (Figure 5 - 29).

- 1) Install pressure gauge (3000 psi) at each test port.
- 2) Start and run engine at full throttle.
- 3) Pressure should read 1900 psi. If not, confirm that the Auxiliary System Pump is putting out 2500 +/- 100 psi as described above.
- 4) Adjust pressure on reducing valve by loosening jam nut on the valve cartridge, insert an allen wrench into the adjusting screw, and turn the screw clockwise to increase pressure, or counter-clockwise to decrease pressure.
- 5) If 1900 psi still cannot be attained, replace pressure reducing valve.

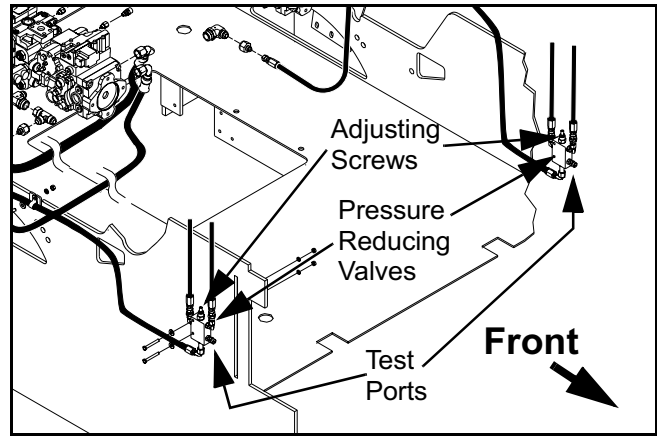

Figure 5 - 29 Pressure Reducing Valves

Rubber Track Hydraulic System

Track Tension Accumulator

Check pre-charge of track tension accumulators on each side.

- 1) Install pressure gauge (3000 psi) at test port marked BTM on the Track Tension Release Valve (Figure 5 - 31).
- 2) Start and run engine at full throttle.
- 3) Pressure should read 1900 to 2200 psi.
- 4) Shut engine off. Pressure on gauge should not change.
- 5) Loosen jam nut on tension release valve cartridge.
- 6) Insert an allen wrench into the adjusting screw, slowly turn it counter-clockwise to open the tension release valve and release hydraulic pressure while carefully watching the gauge.
- 7) The pressure reading should drop off slowly until it reaches the accumulator dry nitrogen pre-charge pressure. When the pressure reaches the pre-charge point, the gauge will drop quickly to 0 psi.
- 8) The gauge reading at the point where it drops quickly to 0 psi should be 1800 psi at 68 degrees F. This reading may be slightly more or less depending the ambient temperature and the hydraulic system temperature.
- 9) If the accumulator dry nitrogen pre-charge is at 1800 psi, then tighten the tension release valve screw by turning it clockwise until snug on its seat.
- 10) Re-tighten jam nut on tension release valve cartridge.
- 11) If the pressure is below 1800 psi when it drops quickly to 0 psi, re-charge the accumulator with dry nitrogen as described in Track Tension Accumulator Pre-Charging procedure in the Paver Technical Manual, then test again.
- 12) If the pressure drops steadily all the way to 0 psi and re-charging the accumulator does not work, then replace the accumulator.

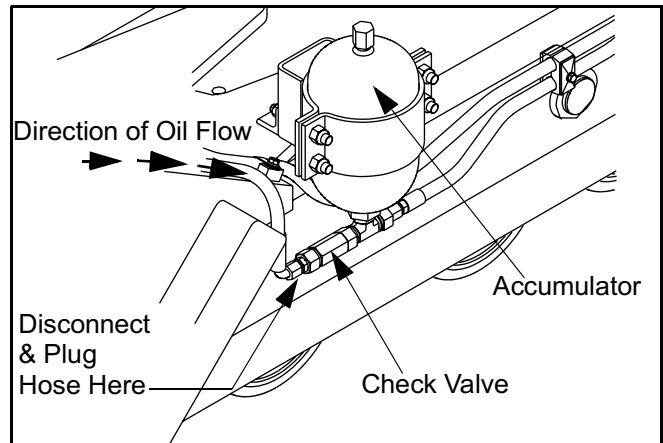

Figure 5 - 30 Track Tension Accumulator

Track Tension Check Valve and Release Valve

Check the operation of the check valve and tension release valve on each side.

- 1) Install pressure gauge (3000 psi) at test port marked BTM on the tension release valve (Figure 5 - 31).
- 2) Start and run engine at full throttle.
- 3) Pressure should read 1900 to 2200 psi.
- 4) Shut off the engine.

Rubber Track Hydraulic System

- 5) Remove the hose going to the check valve and plug the end of the hose (Figure 5 - 30).



Caution: Escaping fluid under pressure can penetrate the skin causing serious injury. Be very careful when disconnecting hydraulic or other lines. Search for leaks with a piece of cardboard. Protect hands and body from high pressure fluids. Any fluid injected into the skin must be removed immediately by a doctor.

- 6) Check the gauge reading to see if it drops off.
- 7) If the gauge reading drops off and oil is leaking from the check valve, replace the check valve.
- 8) If the gauge reading drops off, no oil is leaking from the check valve and the tension release valve is closed, replace the tension release valve.
- 9) Re-test as described above until gauge reading does not drop off.
- 10) Re-install the hose to the check valve.

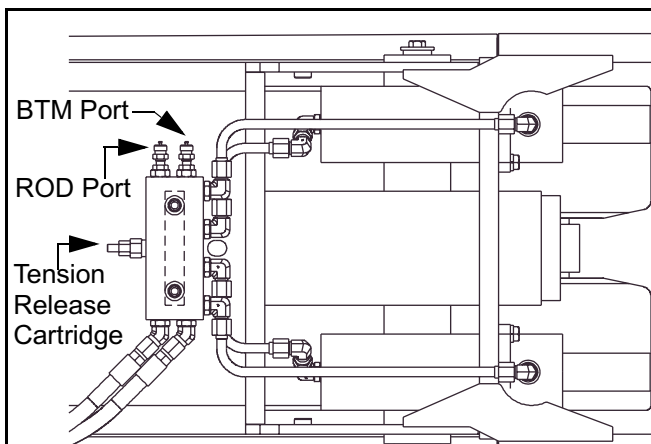

Figure 5 - 31 Track Tension Release Valve

Track Tensioning Cylinders

Check track tensioning cylinders on each side.

- 1) With engine off, remove lines from tension release valve to the rod ends of the cylinders (Figure 5 - 32).



Caution: Escaping fluid under pressure can penetrate the skin causing serious injury. Be very careful when disconnecting hydraulic or other lines. Search for leaks with a piece of cardboard. Protect hands and body from high pressure fluids. Any fluid injected into the skin must be removed immediately by a doctor.

- 2) Cap the fittings on the tension release valves.
- 3) Start and run engine at full throttle.
- 4) With the paver in reverse, brakes released, and the paver moving, there should be no oil leaking from the cylinder rod ports.
- 5) If oil is leaking from the cylinder(s) rod ports, the cylinder(s) must be repaired or replaced.

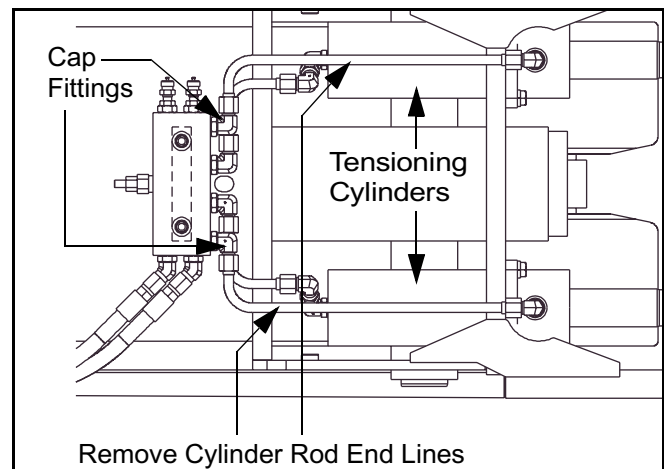

Figure 5 - 32 Track Tensioning Cylinders

Rubber Track Hydraulic System

Track Take-up Valve

Check track take-up valve on each side.

- 1) Install pressure gauge (3000 psi) at test ports marked BTM and ROD on the tension release valve (Figure 5 - 31).
- 2) Start and run engine at full throttle.
- 3) With the paver in travel mode, in forward, brakes released, and the paver moving, there should be 1900 psi at the ROD port and 1900 - 2200 psi at the BTM port.

Note: To achieve the pressure readings in forward, some resistance/load must be present. Travel up a slight incline if necessary. Slowly increase speed until take-up valve shifts.

- 4) With the paver in reverse or stopped, brakes released, and on level ground, there should be 1900 psi at the BTM port only.
- 5) Shut the engine off.
- 6) With the engine off, the pressure on the BTM port should hold at 1900 psi.
- 7) If the pressure bleeds off, check the tension release valve as described above.
- 8) The take-up valve charges the BTM port side of the track tension cylinders each time the brakes are applied. To check this operation:
- 9) Start and run engine at full throttle.
- 10) Place your hand on the hose running to the check valve (Figure 5 - 30).

- 11) Have another person at the paver console cycle the brake switch on and off several times.
- 12) Each time the brakes are applied, you should be able to feel the hose pulse.
- 13) If you cannot feel it pulse, remove the accumulator charging cartridge assembly (Figure 5 - 33), inspect, clean, and re-install in valve body.
- 14) Perform the above test once again.
- 15) If you still cannot feel a pulse in the hose, replace the cartridge assembly in the take-up valve.

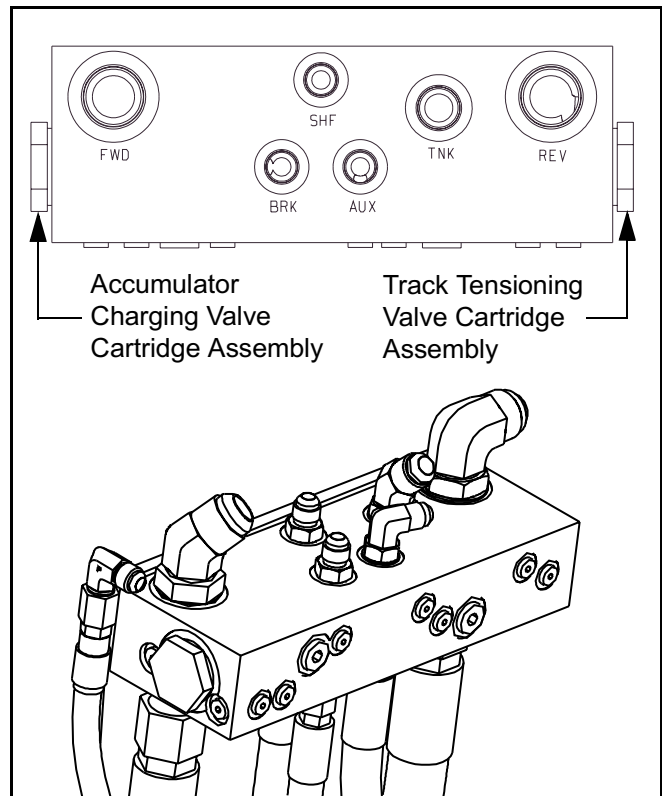

Figure 5 - 33 Track Take-up Valve

Filters

Filters

The paver has seven hydraulic fluid filters and two suction strainers for maximum component protection. There are two travel circuit charge filters, two delivery auger drive charge filters, two spreading auger drive charge filters and one auxiliary pump filter.

Notice: Always replace filters with the filter listed in your paver parts book. Using lower quality filters could lead to expensive damage to the hydraulic system.

The charge filter indicators should be checked daily with the engine at full throttle after the oil is warmed. If a charge filter is used until it is excessively clogged, the filter bypass valve will activate and the indicators on the filter base will indicate in the red. **NEVER** operate with a clogged filter! If the indicator is in the red area, the filter should be replaced. All hydraulic filters should be replaced every 500 hours of operation, when the indicator indicates red, or seasonally, whichever occurs first. Do not wait for the indicator to indicate red before replacing the filter.

Charge Filter Replacement

Two filters mounted on the rear bulkhead filter the fluid from the charge section of the pump and returns the fluid to the main section of the pump. Each filter has an indicator on the base that trips from green to red when the filter is clogged and requires replacement. Filters are replaced by rotating case counterclockwise and removing. To install a new filter, lubricate the O-ring with clean oil and make sure the rubber O-ring is positioned properly on top of filter. (Figure 5 - 34)

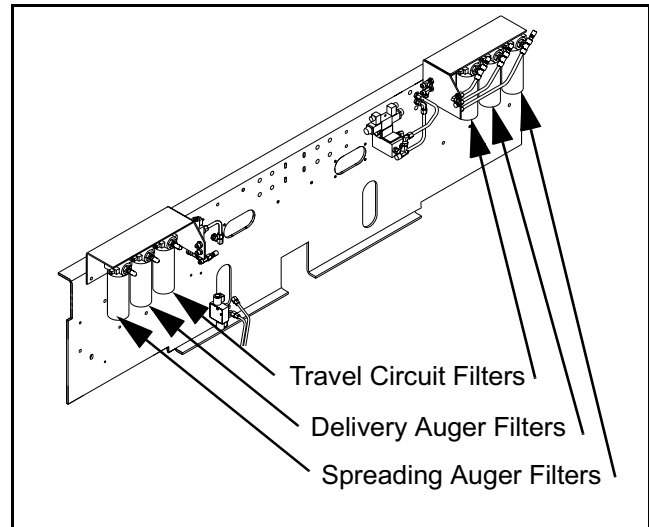

Figure 5 - 34 Charge Filters

Auxiliary Filter

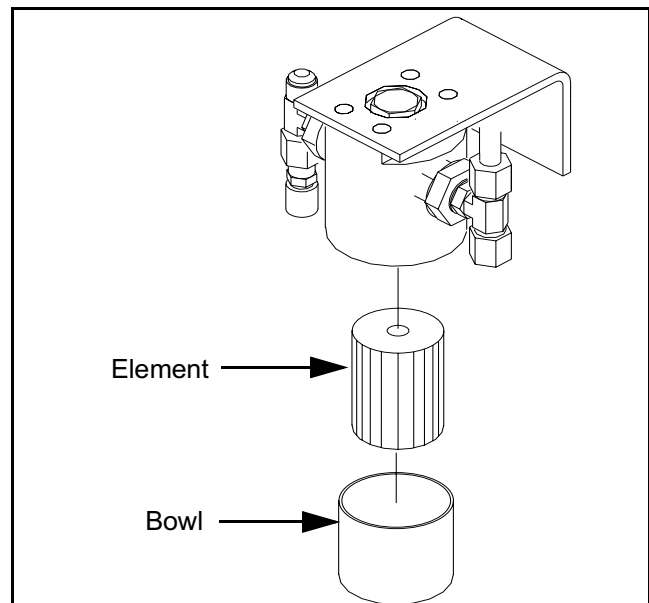

Figure 5 - 35 Auxiliary filter

There is one high pressure auxiliary filter located on the left side of paver on the front bulkhead. This filter consists of filter cap, filter element, and screw-in bowl. To change filter, remove bowl, replace element and reinstall bowl. (Figure 5 - 35)

Filters

Suction Strainers

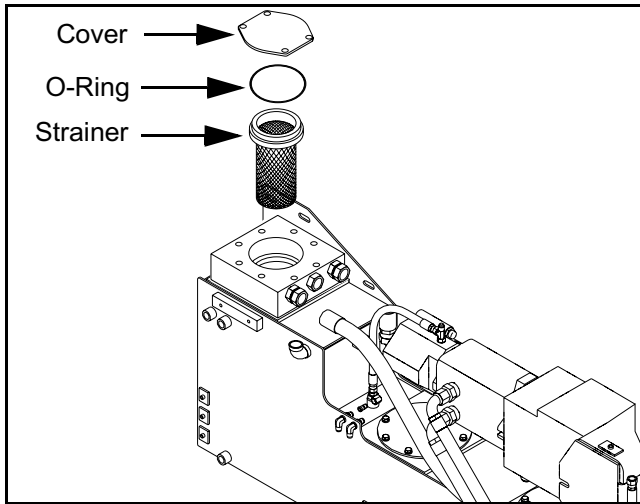

Figure 5 - 36 Suction Strainer

The suction strainers should be removed and cleaned every 500 hours of operation. To clean the suction strainers: (Figure 5 - 36)

- a) Clean the cover and suction manifold to prevent dirt from falling into the hydraulic reservoir.
- b) Remove the cover from the suction manifold to gain access to the strainer.
- c) Remove the strainer from the suction manifold. Be careful not to knock contaminants off the outside of the strainer as it is removed from the manifold.
- d) Clean the strainer with compressed air. Solvent can be used if needed.
- e) Install the strainer in the suction manifold.
- f) Check the condition of the O-ring seal. If the seal is damaged, install a new seal.

Notice: Severe pump damage will occur if the strainer cover is not sealed properly. Air will be drawn into the system causing pump cavitation.

- g) Install the cover.
- h) Pressurize reservoir with 10 psi of compressed air to check suction lines for leakage. To purge lines, loosen fittings slightly while under pressure and retighten.

Solenoid Valves

Solenoid Valves

Solenoid valves mounted on top of each of the valve banks are controlled by toggle switches on the operator’s console. These spool type valves direct the flow to and from the various hydraulic cylinders which control the paver and screed.

All of the 4-way solenoid operated directional valves used on the paver are identical units. They are double-acting valves with spring return of the spool to the neutral position.

When one of the switch contacts is closed, a 12 VDC solenoid is energized and the spool position is shifted by the plunger to connect internal porting so that pressurized hydraulic fluid flows to one end of the hydraulic cylinder(s). Fluid displaced by the moving cylinder rod flows through aligned ports of the same valve bank to the reservoir.

When the toggle switch is moved to the opposite position, the opposite solenoid is energized and the spool is shifted to reverse the pressure and return flow ports so that the cylinder rod moves in an opposite direction.

When the switch is OFF, the spool is centered in the valve body by coil spring action and all ports connected to cylinders are closed so that no flow to or from the cylinders can occur.

Each solenoid uses a DIN connector which contains an LED. The LED lights when 12 VDC is applied. This should be the first check made when determining the cause of a hydraulic failure. Keep in mind this is only a preliminary check; it is possible the LED may be burned out. (Figure 5 - 37)

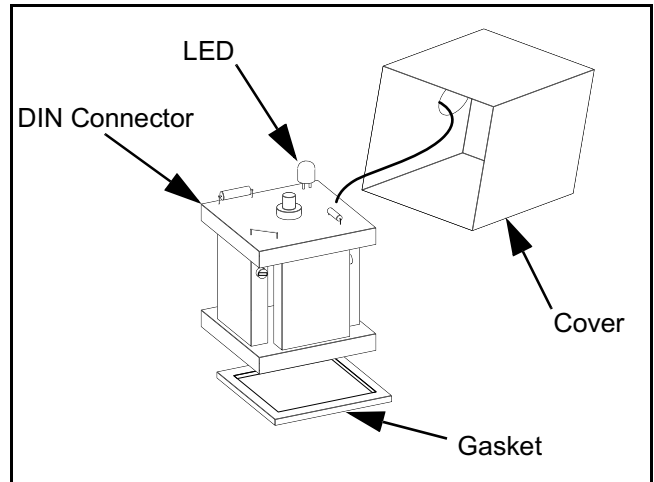

Figure 5 - 37 DIN Connector LED

If one of the paver functions does not operate, refer to the Technical Manual for troubleshooting and repair information.

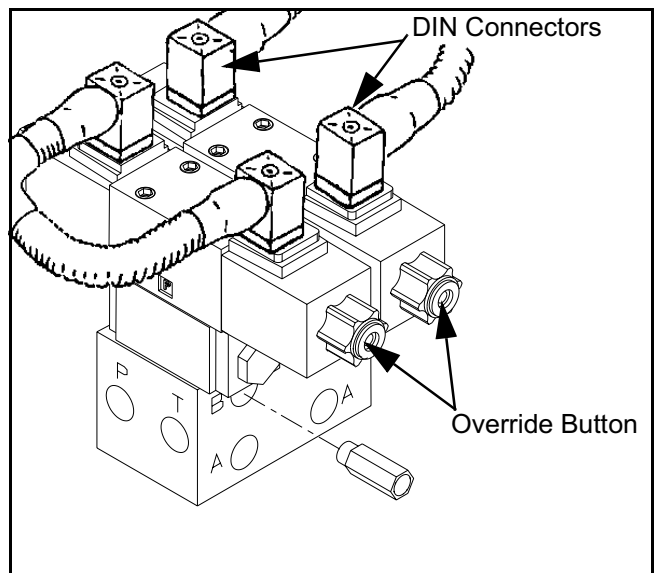
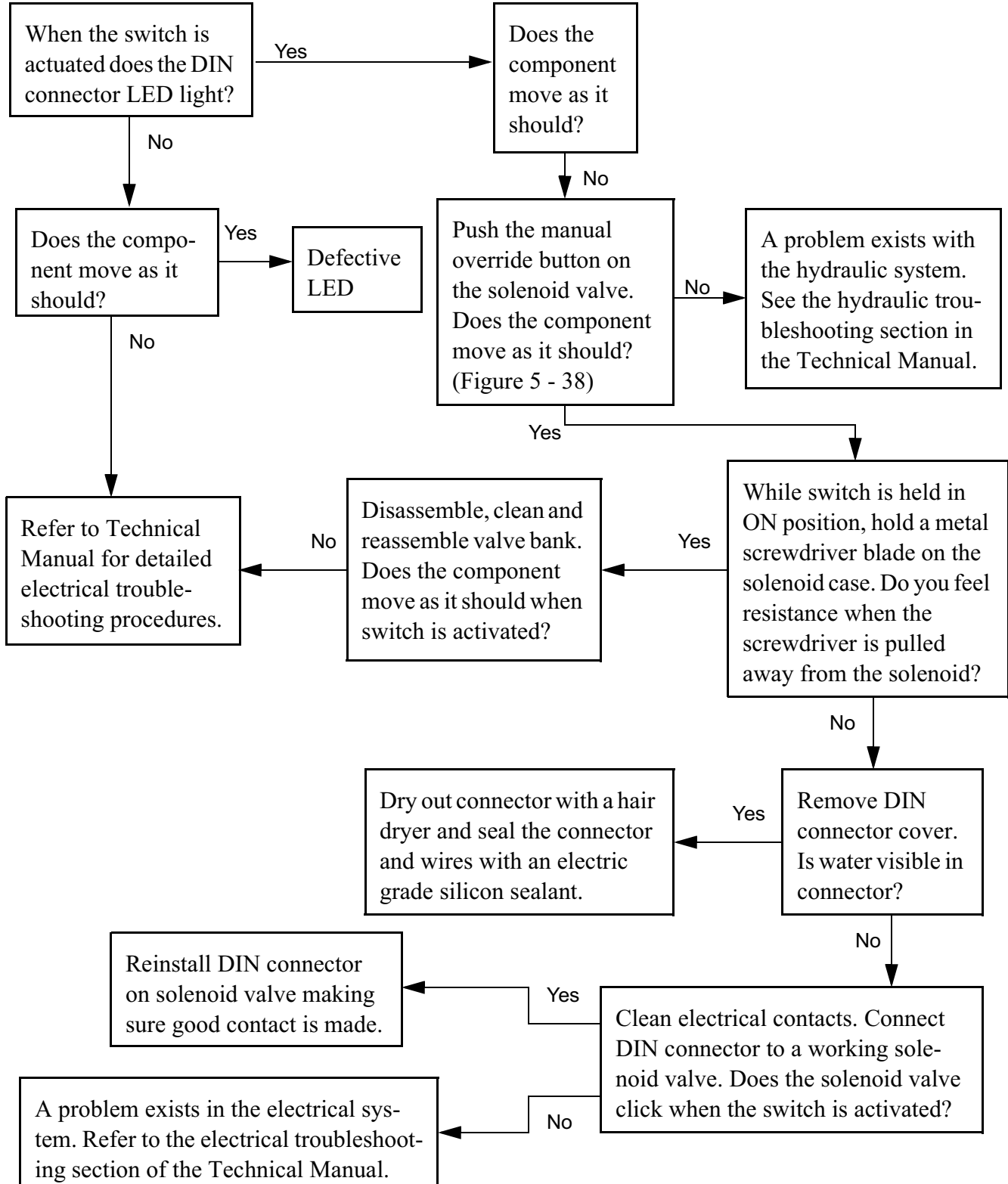

Figure 5 - 38 Solenoid Valve Override Button

Solenoid Valves



Solenoid Valves

Manual Testing of Solenoid Valves

If the spool cannot be manually shifted or fails to return by spring action to the OFF position, the valve should be completely dismantled, inspected, cleaned, and tested. If manual shifting succeeds in operating the system, try electrical operation again to see if the coil's magnetic force is strong enough to consistently move and hold the plunger.

Removing/disassembling Valve Bank



Warning: Before removing any hydraulic hoses or valves make sure the hopper wings, screed, frame raise, and pull point cylinders are lowered as far as possible.

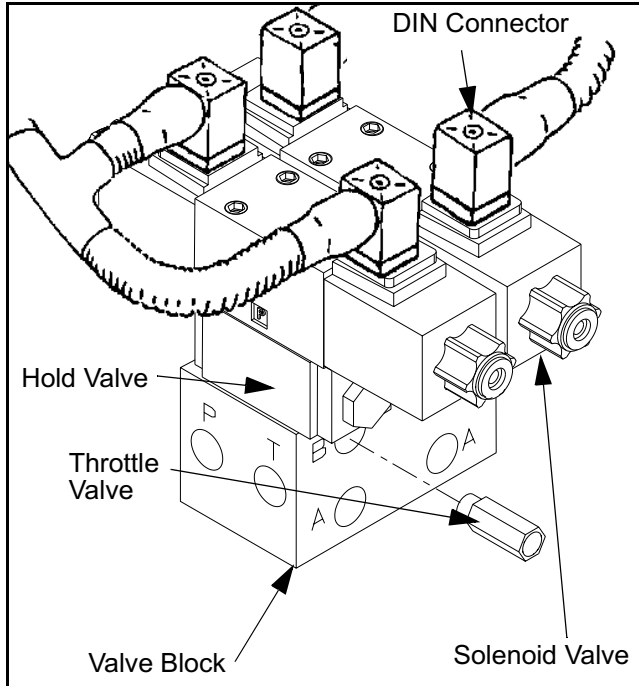

Figure 5 - 39 Typical Valve Bank

When it is necessary to detach and disassemble any of the valves which make up a valve bank assembly, it is necessary that the bank be

disconnected from hydraulic hoses, unbolted from the mounting brackets, and moved to a totally clean work bench area. The detached unit should also be plugged and washed clean externally before any disassembling is started. The following instructions should be used to maintain the frame raise, truck hook, hopper wings, screed lift, left tow point, and right tow point valve banks. Some of the components referred to may not be used on all valve banks. (Figure 5 - 39)

- 1) Remove the screw retaining each of the DIN connectors to the solenoids. Unplug the DIN connector from the solenoid.
- 2) Mark each hose and its companion port on the valve bank with a code that will assure reconnection is made to the correct port when the bank is installed. If hoses and ports are not marked, refer to schematic diagrams for correct connection details.
- 3) As each hose is disconnected, plug the end of the hose and port with a clean plastic plug.
- 4) Remove the nuts which hold the valve bank to the paver and remove the valve bank.

Notice: Scrub and rinse the exposed surfaces of the entire valve bank to remove all dirt and place the assembly on a clean working surface.

- 5) Remove the four stud nuts which hold the valve bank together and disassemble the valve bank. Retain all of the O-rings which will be between each of the valve bank components.
- 6) Remove the throttle valve from the valve block.

Valve Bank Components

Valve Bank Components

Throttle Valve

The throttle valve allows unrestricted flow in one direction and metered or restricted flow in the opposite direction. In the case of screed lift, flow in RAISE direction is unrestricted while return flow in the LOWER direction is restricted by a 3/32" diameter orifice. This permits the screed to raise quickly but to descend at a slower, safe rate.

A drilled poppet is the only moving part in a throttle valve. The valve can be easily inspected for presence of foreign matter in orifice. The orifice can be cleaned using a piece of 1/16" diameter wire and compressed air. If probing succeeds in clearing a blockage, the valve should then be flushed clean with mineral spirits solvent. These same valves are used in the hopper wing circuit.

Holding Valve

Hold valves are used on the frame raise, hopper wings, screed lift, and tow point valve banks. If the engine stalls or a hydraulic line breaks between the pressure source and valve, the holding valve locks the cylinder in its current position to prevent the screed, hopper wings, etc. from dropping unexpectedly. When the hydraulic line is repaired and the engine is restarted the valve continues to work normally.



Warning: Holding valves do not contain any serviceable or replaceable parts. Do not attempt to disassemble and repair a holding valve cartridge.

A holding valve consists of a valve body and one or more valve spools. If a holding valve is not working properly remove the valve and blow the

valve body and spool off with compressed air. Reinstall the valve. If it still does not work, replace the valve.

Flow Control Valve

The flow control valve is used in the tow point and truck hook cylinders to control the speed at which the cylinders move. The valve consists of a valve body with a needle valve cartridge.

To clean the flow control valve, remove the cartridge, blow the valve and valve body out with compressed air, and reinstall the cartridge.

Assembling Valve Banks

Assembling Valve Banks

The valve bank should be assembled on a clean lint-free shop towel in a clean work area. All components should be wiped clean before assembly.

- 1) Inspect all O-rings before assembly. Replace any O-rings that are cracked, damaged, dried out, or not flexible.
- 2) Lubricate each O-ring with clean oil or light grease before assembly.
- 3) Place O-rings in the O-ring recesses . Make sure O-rings do not get pinched during assembly.
- 4) Refer to illustrations on the following page for proper orientation of each valve bank component.
- 5) To ensure that each component is properly oriented during assembly the following procedure should be followed for each component:
 - a) apply a thin coating of oil or grease to the O-rings
 - b) install the next valve stack component on the studs
 - c) remove the component

The O-rings will leave a circular oil mark on the mating valve surface. If the component was installed in the proper orientation the four oil ports in the mating component surface will be centered in the four oil marks left by the O-rings. If the oil marks do not line up with the oil ports, check the orientation of the component and reinstall.



Caution: When assembling valve bank, tighten screws alternately, evenly, and with not more than 48 to 60 inch-pounds of torque. It is important that the machined contact surfaces and O-rings make a leak-free contact without excessive screw tightness which can warp the valve body and cause binding of the spool.

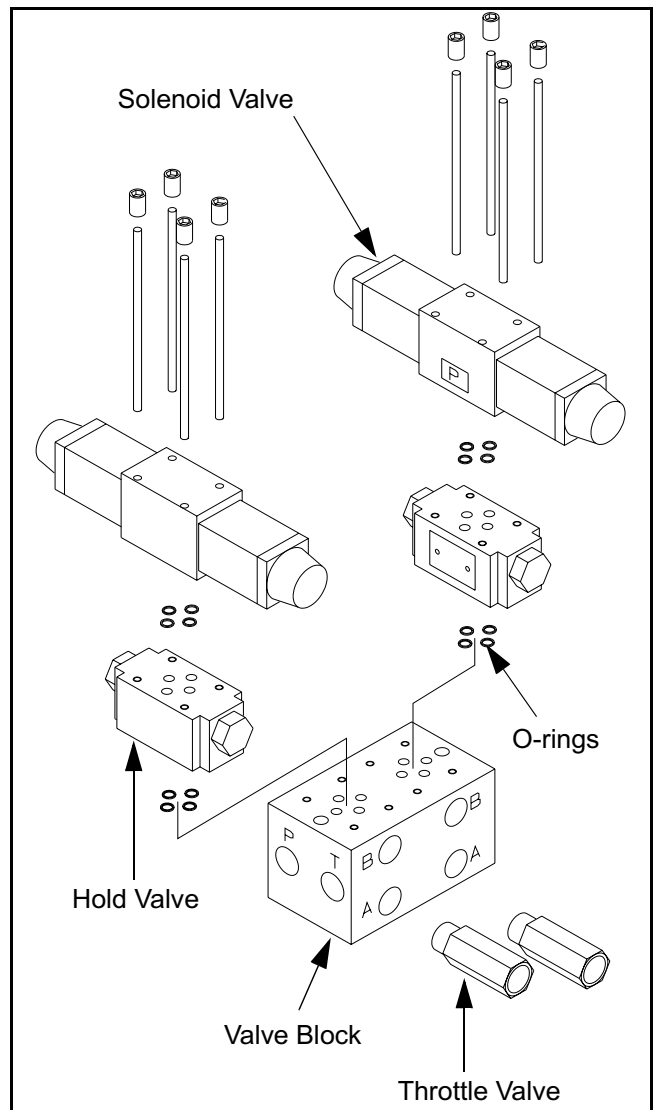

Figure 5 - 40 Frame Raise/Screed Lift Valve Bank

Assembling Valve Banks

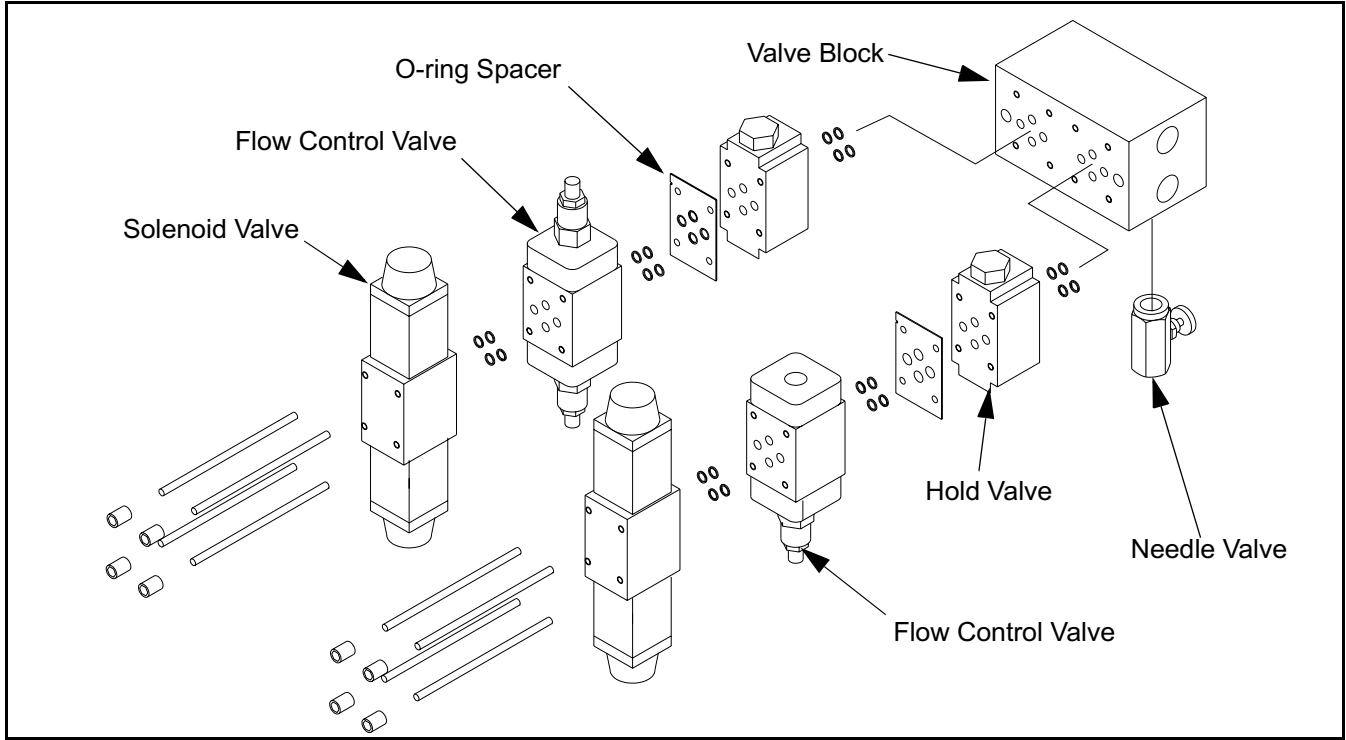

Figure 5 - 41 Truck Hook/Left Tow Point Valve Bank

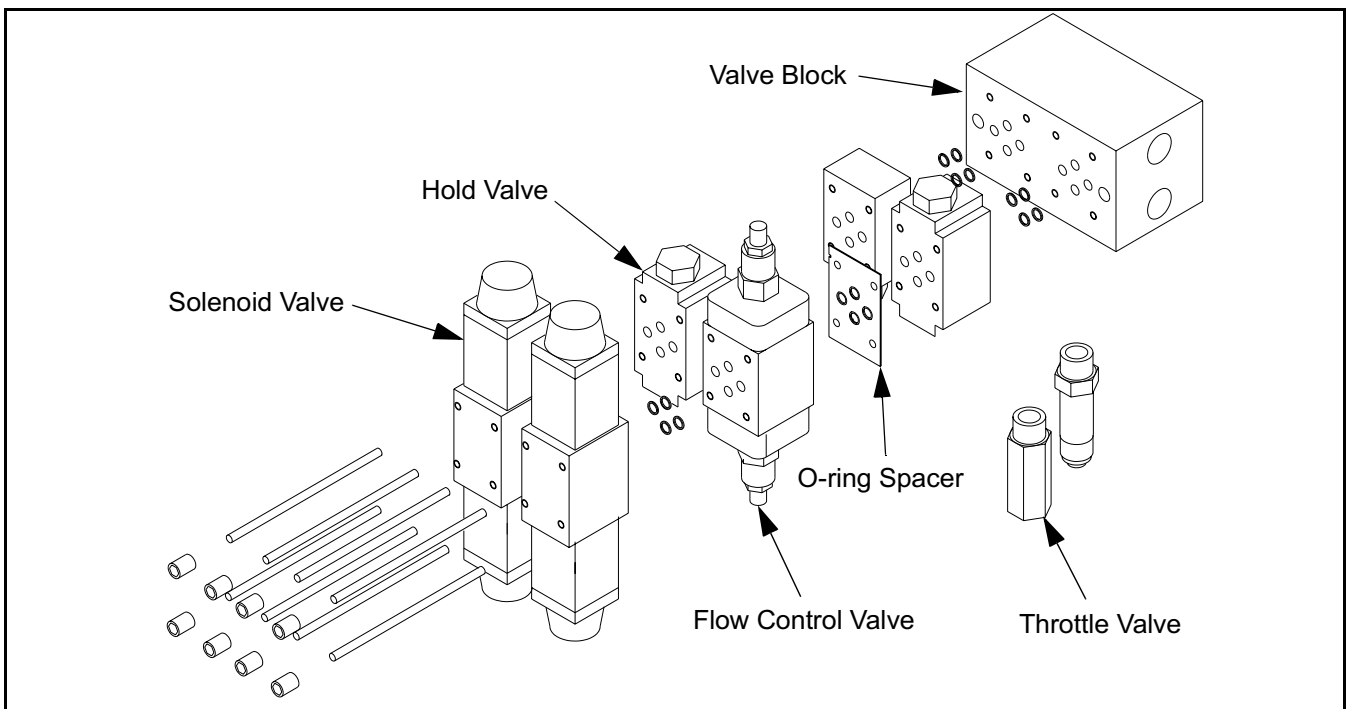

Figure 5 - 42 Hopper Wings/Right Tow Point Valve Bank

Hydraulic System Troubleshooting

Hydraulic System Troubleshooting

For more in depth information refer to the Paver Technical Manual.

Hydraulic Fluid Overheating

The following factors can cause fluid temperature above 160°F:

- 1) **Low Fluid Level in Supply Tank:** When the fluid level is kept high more heat is radiated from the tank walls and the circulating (cooling) time is increased. Keep fluid level FULL on the sight gauge, especially when outdoor temperature is high.
- 2) **Cooler Not Functioning Properly:** The flow of hydraulic fluid must be free and unrestricted at all times. The air passages through the radiator and cooler must be kept clear of dirt, fibers, and insects so that an unrestricted flow is assured at all times during engine operation. The cooler is placed ahead of the engine radiator and will therefore become plugged first by airborne foreign matter.

If increased cooling capacity is needed, an auxiliary oil cooler or remote oil cooler system can be installed.

Failing Pumps or Motors

In the event that one of the pumps or one *of* the motors is beginning to fail internally, excessive heat will usually be produced. When this occurs the fluid temperature will become abnormally high. It is recommended that a “touch” test be made immediately in an effort to determine where an internal failure of parts is beginning to occur. The hottest fluid will be passing back to the reservoirs through a case drain hose. It is sometimes possible to touch the fittings of each of these hose lines and detect an

extremely hot one which feels different from the others. If paving can be suspended for a “cooling off” period it is easier to detect the difference at the next start-up as the line from the failing unit will heat up much faster than the others. If a “hot” pump or motor is detected, have the pump or motor serviced immediately.

Notice: If the conveyors are not feeding equal quantities of material, the one moving the most material will be slightly hotter than the other. This should be considered in making temperature comparisons. Temperature checks can also be made by taping an accurate indicating thermometer to the case drain fittings.

Air in the Systems

The suction force developed by each of the six hydraulic pumps on the paver draws the fluid from reservoirs through hose lines to the charge pumps. With all points on these suction lines under negative pressure, air can be drawn in wherever an opening exists. When air is mixed with the fluid entering any of the pumps, an abnormal situation is created and serious operating problems develop.

The charge pumps which force feed the drive pumps cannot develop enough fluid pressure to keep the main pump passages filled with fluid. Pump pressure fluctuates and paver operation becomes jerky and erratic as the pumps cavitate.

Causes of Air in System

- 1) Low fluid level in reservoirs. When fluid level approaches tips of suction pipes near bottom of reservoir, air begins to enter along with fluid. Always keep tank filled to sight gauge level.

Hydraulic System Troubleshooting

- 2) Air leakage through an opening at any connection in fluid supply lines to pumps. If gasket at top of a filter element is not sealing properly, air will be drawn in.

Locating Air Leaks

If an air leak is suspected but cannot be located or confirmed, the best way to test for it is by pressurizing the reservoir with air and finding the point of fluid leakage. To do so, remove both breather fill caps and attach an air line which includes a pressure regulator and gauge so that **not more than 15 psi** air pressure will be applied. Any point where fluid leakage occurs under air pressure is a point of air entry.

When fluid leakage is located and stopped, pressurize reservoir to 15 psi, close air inlet valve, and see if system will hold pressure for an hour or two without dropping. This will verify that all leaks have been stopped and air will no longer enter the system when operation is resumed. Remove plugs from fill holes and replace with breather fill caps.

Steel Track Maintenance

Section 6 - Mechanical Maintenance

Steel Track Maintenance

The track is designed to be virtually maintenance free. Proper cleaning and lubrication at the end of each paving day will maintain trouble free operation. However, neglect of the tracks can be expensive. Every time paver is cleaned, the track pins should be sprayed with light oil to lubricate them preventing them from rusting and binding.

The Grayhound track paver uses a tension cylinder mounted above the final drive that maintains a constant volume of pressurized oil to the track adjusting cylinders. When the track encounters an obstacle, the system allows the tensioning idler to recoil rather than stretch or break the track. When the obstacle is cleared the system returns to the previous track tension adjustment.

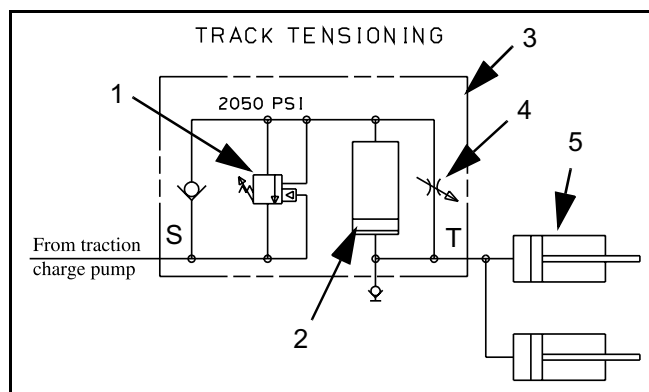

- 1 - Counterbalance valve
- 2 - Rodless piston cylinder
- 3 - Tensioning cylinder assy.
- 4 - Needle valve
- 5 - Idler tension cylinders

Figure 6 - 1 Track tension hydraulic circuit

The track tensioning cylinder assembly consists of a cylinder with a rodless piston, a needle valve, and a counterbalance valve. (Figure 6 - 1) The piston keeps the oil from the idler tensioning cylinders separated from the main oil supply. When the track encounters an obstacle, it forces oil from the idler

cylinders into the bottom side of the rodless cylinder. When the obstruction is cleared, pressurized oil from the traction charge pump forces the tensioning cylinder down which forces idler cylinders to move back to original position.

The needle valve is used during track tensioning to bring the volume of oil on the bottom side of the rodless cylinder back to the proper level. The counterbalance valve allows oil to flow freely from the top side of the rodless cylinder to the tank when the track encounters an obstacle.

Steel Track Tensioning

If the track looks like it may be getting loose, it can be tested by placing a board or straight edge on the track between the front idler and the first top roller. If the gap between the bottom of the board and the top edge of the track is greater than 3/4", the track tension must be adjusted. (Figure 6 - 2)

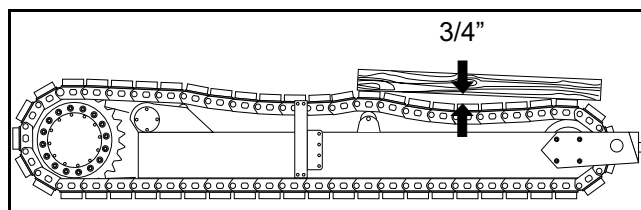

Figure 6 - 2 Checking track tension

Important: Perform track tension checks and adjustments when the paver is at running temperature. Adjusting track tension when the paver is cold could lead to over-tensioning of the track.

Adjust track tension as follows:

- 1) Start the engine.
- 2) Open the needle valve slowly to allow the track to retension. (Figure 6 - 4)

Steel Track Maintenance

3) Drive the paver forward and backward slowly.



Warning: Be very careful when reaching over the moving track. Keep feet and loose clothing away from the moving track and rollers.

4) Stop the paver and close needle valve.

5) A properly tensioned track should have a 3/8" to 1/2" gap between a straightedge and the track. (Figure 6 - 3)

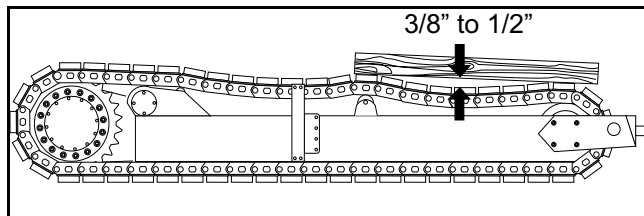

Figure 6 - 3 Proper Track Tension



Warning - Overtightening the track can cause serious damage to the track, idler or drive.

Steel Track over-pressurizing

If the track adjusting system is over-pressurizing during operation, the following procedure must be performed. It is a good idea to perform this check once each season to verify the tensioning cylinder is in good condition.

Notice: Do not run the paver while the system is over-pressurized. Running with an over-pressurized system could damage the track and sprockets.

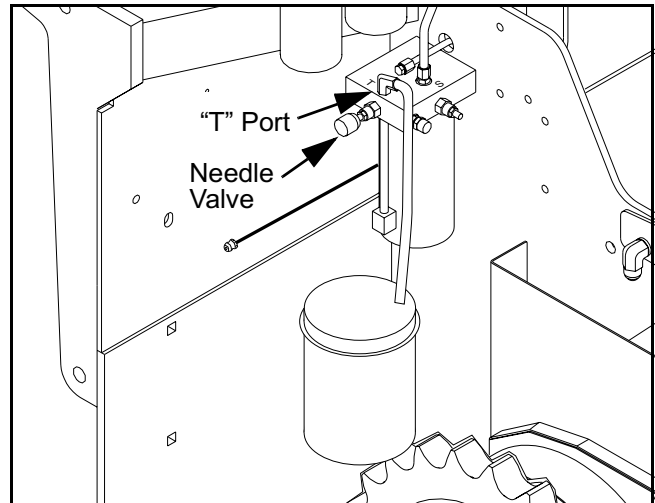

Figure 6 - 4 Bottoming Tension Cylinder

- 1) Disconnect the line from the "T" port on the track tension cylinder. Install a plug into the disconnected line. (Figure 6 - 4)
- 2) Attach a drain line to the "T" port and run the other end into a bucket.
- 3) Close the needle valve by rotating clockwise.
- 4) Start the engine and run at full throttle.
- 5) If the track was tensioned properly, no oil will flow into the bucket.
- 6) If only a small amount of oil drains into the bucket, the piston and counterbalance valve are working properly and track will tension properly.
- 7) If oil continues to flow into the bucket, the piston or counterbalance valve is leaking and must be repaired.
- 8) Turn the engine off and reconnect the hydraulic line to the "T" port.

Steel Track Maintenance

Steel Track Relief Pressure

In addition to adjusting the track tension, the track relief pressure should be checked at least once each season. Refer to the Paver Technical Manual for information on checking track relief pressure.

Steel Track Installation



Warning: When installing or removing the track, keep hands and feet out from under the track/paver.



Caution: When disconnecting oil line in the following step, allow oil pressure to bleed off by loosening hose end first. When all pressure has been vented, remove oil line.

- 1) Disconnect the track tensioning oil line from the “T” port on the track tensioning cylinder. (Figure 6 - 4)
- 2) Jack up the track frame until the track can be slid under the bogies. Support the paver with blocking capable of supporting the weight of the paver.

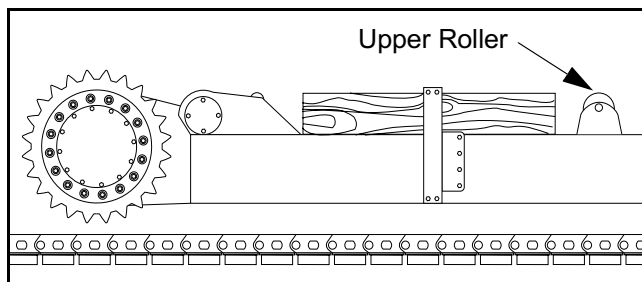

Figure 6 - 5 Place board between sprocket and roller

- 3) Place boards between the sprocket and upper roller as shown. This elevates the track allowing it to clear the upper roller while driving the track toward the idler. (Figure 6 - 5)

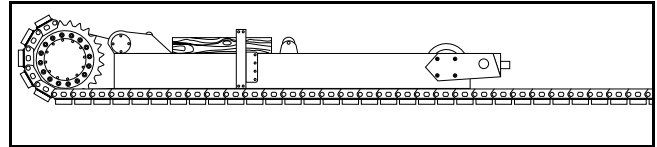

Figure 6 - 6 Roll out track

- 4) Place the track under the paver with the end of the track marked OPEN positioned on the sprocket as shown and the other end stretched out in front of paver. (Figure 6 - 6)

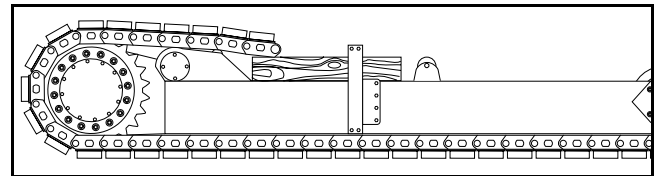

Figure 6 - 7 Rotate sprocket to install track

- 5) Start the engine and rotate the sprocket until the end of the track marked OPEN just touches the front idler. (Figure 6 - 7)

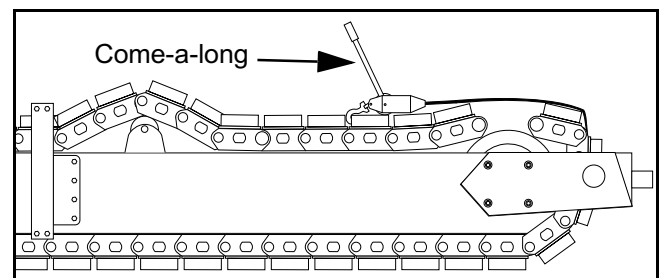

Figure 6 - 8 Pull track ends together

- 6) Use a come-a-long or hoist to lift and draw the track ends together. (Figure 6 - 8)
- 7) Place blocks under the track assembly as shown to support loose track end.

- 8) Remove paint from interlocking ribs of master link and lightly grease contact surfaces. Clean bolt holes and threads, and apply anti-seize or grease to track shoe bolts.

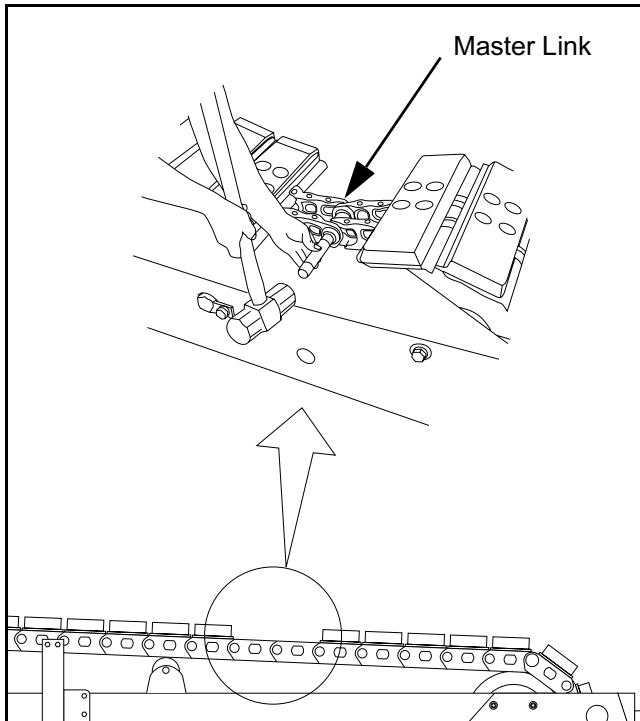

Figure 6 - 9 Connecting Master Link

- 9) Connect the ends of the track by installing the master link pin. (Figure 6 - 9)

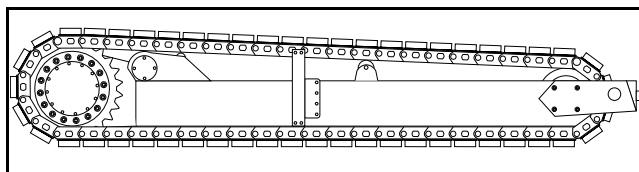

Figure 6 - 10 Install track pad

- 10) Once master link is connected, apply Loctite to bolts and install track pads. (Figure 6 - 10)

Steel Track Removal

To remove the track assembly, perform Track Installation procedures in reverse order.

Steel Track Maintenance

Replacing Steel Track Drive Sprockets

When sprocket teeth are worn, the sprocket can be replaced or turned around to restore sprocket teeth to new condition. Perform the following procedure if sprocket replacement is necessary.

- 1) Rotate the track until the master link is positioned on the sprocket.
- 2) Disconnect the track tensioning oil line from the “T” port on the track tension cylinder. (Figure 6 - 4)

Important: After splitting the track, do not remove it completely. Position the track so it will not interfere with sprocket removal.

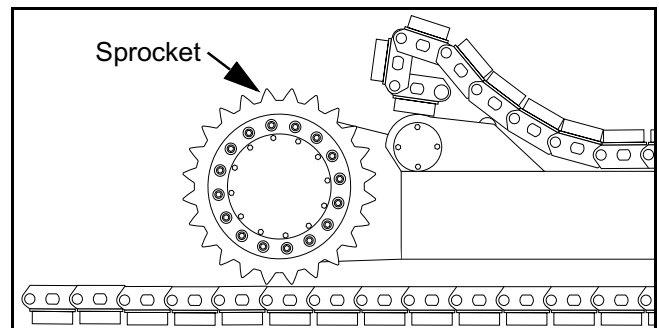

Figure 6 - 11 Remove link pin to separate track

- 3) Split the track and pull ends away from sprocket. (Figure 6 - 11)
- 4) Remove cap screws securing sprocket and remove sprocket from hub assembly.
- 5) Clean sprocket cap screws and bolt holes and apply Loctite to cap screws.
- 6) Place new or rebuilt sprocket onto hub assembly and secure with cap screws. If desired, the old sprocket can be turned around to utilize the opposite side of teeth.

Steel Track Maintenance

- 7) Connect the track as shown in the Track Installation Procedure.

Repairing Oscillating Bogie Rollers

There are four oscillating bogie assemblies which support the weight of the paver on each side. Each bogie contains two rollers which are oil-filled and sealed. These rollers should not require attention for entire life of the bearings and oil seals inside.

When a paver has been in service for a long period of time the roller bearings will begin to wear. Severely worn bearings will cause operating problems. At least once each season, each roller should be relieved of all loading and checked for end play, which indicates bearing wear. If roller bearings are worn out (excessive wobbling), the roller assembly should be replaced.

Accumulation of dust and dirt on the roller is an indication that a roller is leaking. If this is detected, the roller should be removed and repaired as described in the following instructions. Do not delay this repair otherwise the roller bearings may be operating without lubrication which will quickly destroy the bearings.

- 1) Break the track as described in the previous section.
- 2) Jack up track frame until the track is completely off the ground and install safety blocks capable of supporting the weight of the paver.
- 3) Remove cap screw and pull the oscillator shaft out. Bogie should fall down to the track.



Caution: Roller should be disassembled in a clean environment. Do not allow dirt to contaminate bearings and seals inside roller.

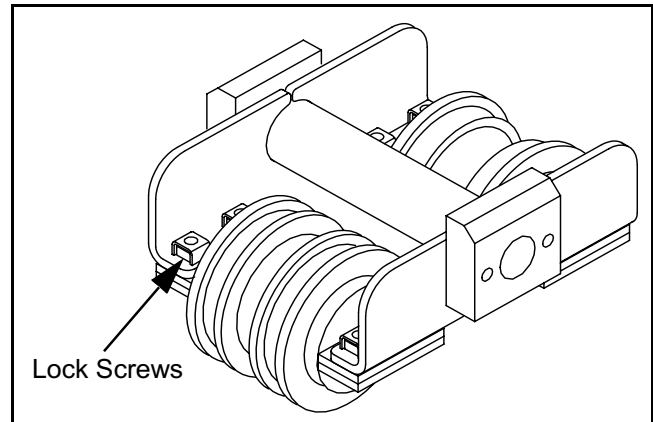

Figure 6 - 12 Track roller

- 4) Remove four lock screws which secures the roller to the bogie. (Figure 6 - 12)
- 5) Remove shaft housing cap.

Important: Observe the positioning of the seals while removing, the new seals will need to be installed in the same manner.
- 6) Remove polished metal seal and both rubber seals. Drain oil and stand the roller on end with the open end up. Pour one pint of fresh oil along the flat portion of the shaft.

Note: Rollers are factory-filled with Mobil Glygoyle 30 synthetic oil. Mineral oils are not compatible, so do not mix.
- 7) Install new seals.
- 8) Install shaft housing cap and secure to bogie frame with four lock screws.
- 9) Install bogie assembly in track frame.
- 10) Reconnect track as described in previous section.

Rubber Track Maintenance

The rubber track is designed to be virtually maintenance free. Proper cleaning at the end of each paving day will maintain trouble free operation. However, neglect of the rubber tracks can be expensive.

Rubber Track Tension

The tracks on Grayhound rubber track pavers (Figure 6 - 13) do not require periodic adjustment. They are self-adjusted by applying a pre-set hydraulic pressure supplied by the auxiliary pump to the tensioning cylinders. The tracks have an automatic system that allows them to recoil and return to tension if an impact is encountered. If tracks appear loose, troubleshoot the track hydraulic system (see Section 5).

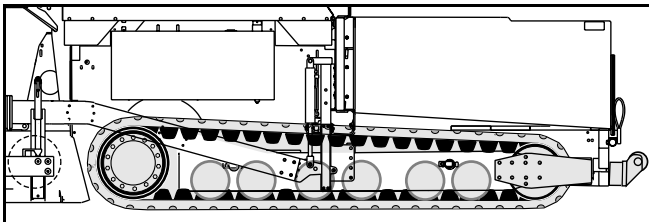

Figure 6 - 13 Rubber Track

Rubber Track Installation & Removal



Warning: When installing or removing the track, keep hands and feet out from under the track/paver.

Removal

Release the track tension by:

- 1) Shut off engine and remove key from ignition.
- 2) Loosen jam nut on tension release valve cartridge (Figure 6 - 14).

- 3) Insert an allen wrench into the adjusting screw, slowly turn it counter-clockwise to open the valve and release hydraulic pressure.
- 4) Insert a porta-power between the track frame nose plate and the track (Figure 6 - 15) (protecting track from damage by inserting a block of wood or steel plate between ram and track).
- 5) Extend porta-power to loosen track.
- 6) Remove porta-power.

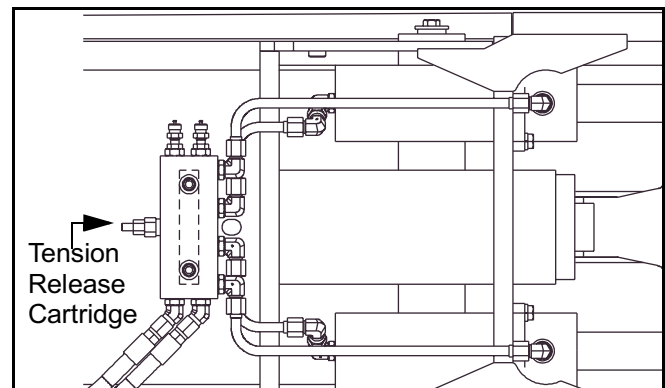

Figure 6 - 14 Release Rubber Track Tension

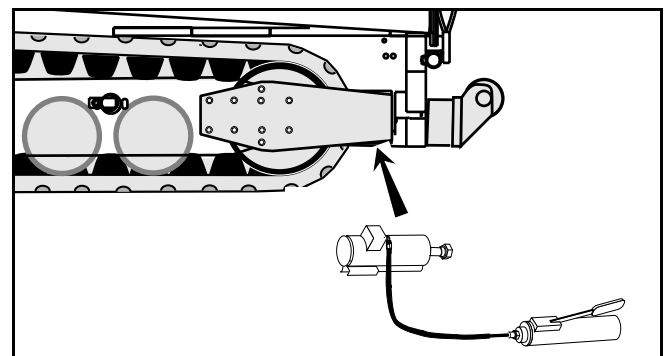

Figure 6 - 15 Insert Porta-Power

- 7) Jack up track frame until the track will slide out from under the bogies. Support paver with blocking capable of supporting its entire weight.

Rubber Track Maintenance

- 8) Un-bolt and remove screed pull arm.
- 9) Un-bolt slope beam rod from tow point cylinder mounting assembly.
- 10) Un-bolt tow point cylinder mounting assembly from track frame. Swing assembly out of the way and secure to paver. If desired, disconnect hydraulic hoses to cylinder, plug to prevent contamination, and set assembly aside.
- 11) Un-bolt and remove outer half of drive wheel.
- 12) Un-bolt and remove outer front idler nose plate.
- 13) Rubber track may now be pulled off track frame.

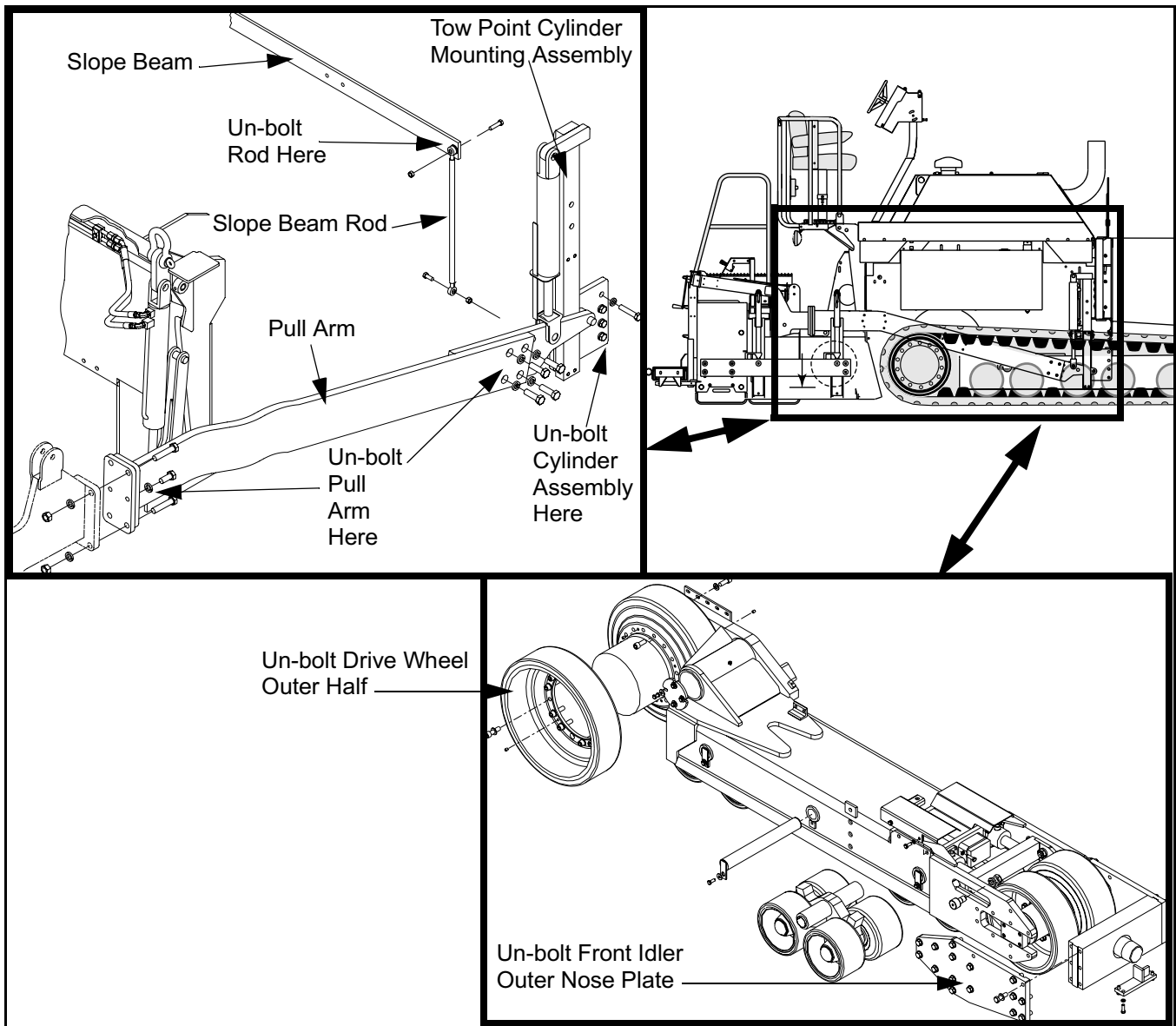

Figure 6 - 16 Rubber Track Removal

Rubber Track Maintenance

Rubber Track Installation

- 1) With track removed as described above, clean track frame and wheels of debris, dirt, and asphalt build-up.
 - 2) Slide track onto frame making sure center lugs are in alignment between bogie wheels and front idler.
 - 3) Install front idler outer nose plate (Figure 6 - 16).
 - 4) Install outer half of drive wheel.
 - 5) Install tow point cylinder mounting assembly on track frame. If hydraulic hoses were disconnected, re-connect to the appropriate fittings.
 - 6) Install slope beam rod back onto tow point cylinder mounting assembly.
 - 7) Install screed pull arm.
 - 8) Insert an allen wrench into the adjusting screw on tension release valve cartridge (Figure 6 - 14). Slowly turn it clockwise until the valve seats.
 - 9) Tighten jam nut on valve cartridge.
 - 10) Track is now ready to be re-tensioned.
- 3) The track tensioning cylinders should extend and the track should tighten.
 - 4) If the track does not tighten or the system does not operate properly, see Section 5 for troubleshooting procedures.

Rubber Track Re-tensioning

- 1) Start engine and run at idle.
- 2) Set brakes to ON and allow the track tensioning system to charge itself.

Rubber Track Maintenance

Repairing Rubber Track Bogie Wheels

There are six oscillating bogie wheel assemblies (three on each side) which support the weight of the paver. Each assembly contains four bogie wheels which are fitted with tapered roller bearings packed with roller bearing grease and sealed to prevent the entry of dirt and debris. The bogie wheels should not require attention for the entire life of the bearings and seals.

When a paver has been in service for a long period of time, the roller bearings will begin to wear. Severely worn bearings will cause operating problems. At least once each season, each bogie assembly should be relieved of all loading and each wheel checked for end play. Each bogie wheel should not have any end play, but a preload of .002" - .004".

Bogie Wheel Assembly Removal

To remove the bogie wheel assemblies for repair or replacement of parts:

- 1) Perform the procedure See "Rubber Track Installation & Removal" on page 6. of this section to relieve rubber track tension. Also see (Figure 6 - 14) and (Figure 6 - 15).

Notice - It is not necessary to completely remove the track to service the bogie wheel assemblies. The paver must only have the track tension relieved and be raised off the ground far enough for the assemblies to clear the bottom of the track frame and the track center lugs.



Warning: When removing the bogie wheel assemblies, keep hands and feet clear from between the track and wheel assemblies.

- 2) Remove shaft from track frame that holds center bogie wheel assembly to frame (Figure 6 - 17). This will allow the assembly to drop onto the track.
- 3) Remove the bogie wheel assembly by drawing it out over the center lugs of the track.
- 4) Remove the front and rear bogie wheel assemblies, as described above, after the center assembly has been removed.

Note: If the track has been removed, each individual bogie wheel assembly may be removed without first removing the center assembly.

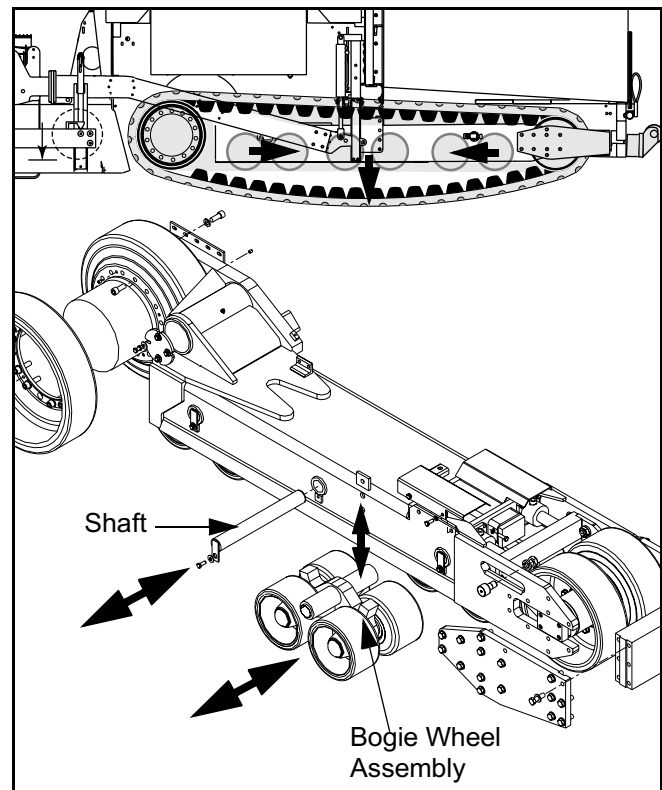

Figure 6 - 17 Bogie Wheel Assembly Removal

Rubber Track Maintenance

Bogie Wheel Assembly Installation

To install bogie wheel assemblies after they have been removed from track frame, simply reverse the process listed in See “Bogie Wheel Assembly Removal” on page 9. of this section.

Bogie Wheel Bearing Replacement

If it is determined that bearing replacement is necessary, proceed with the following:

Disassembly

- 1) Remove bogie wheel assembly as described above. See See “Bogie Wheel Assembly Removal” on page 9. and (Figure 6 - 18) below.
- 2) Remove grease cap (12).

- 3) Bend back locking tab on lock washer (10) and remove bearing nut (11).

Note: If bearings are to be re-used, keep cups and cones in matched sets as originally installed.

- 4) Slide bogie wheel (3) off hub. The keyed flat washer(9), outer bearing cup (7) and cone (6) will be removed with the wheel as will the inner bearing cup (5).
- 5) Remove inner bearing cone (4) and shaft seal (8).
- 6) Clean all parts with mineral spirits solvent, inspect for damage, and replace as necessary.

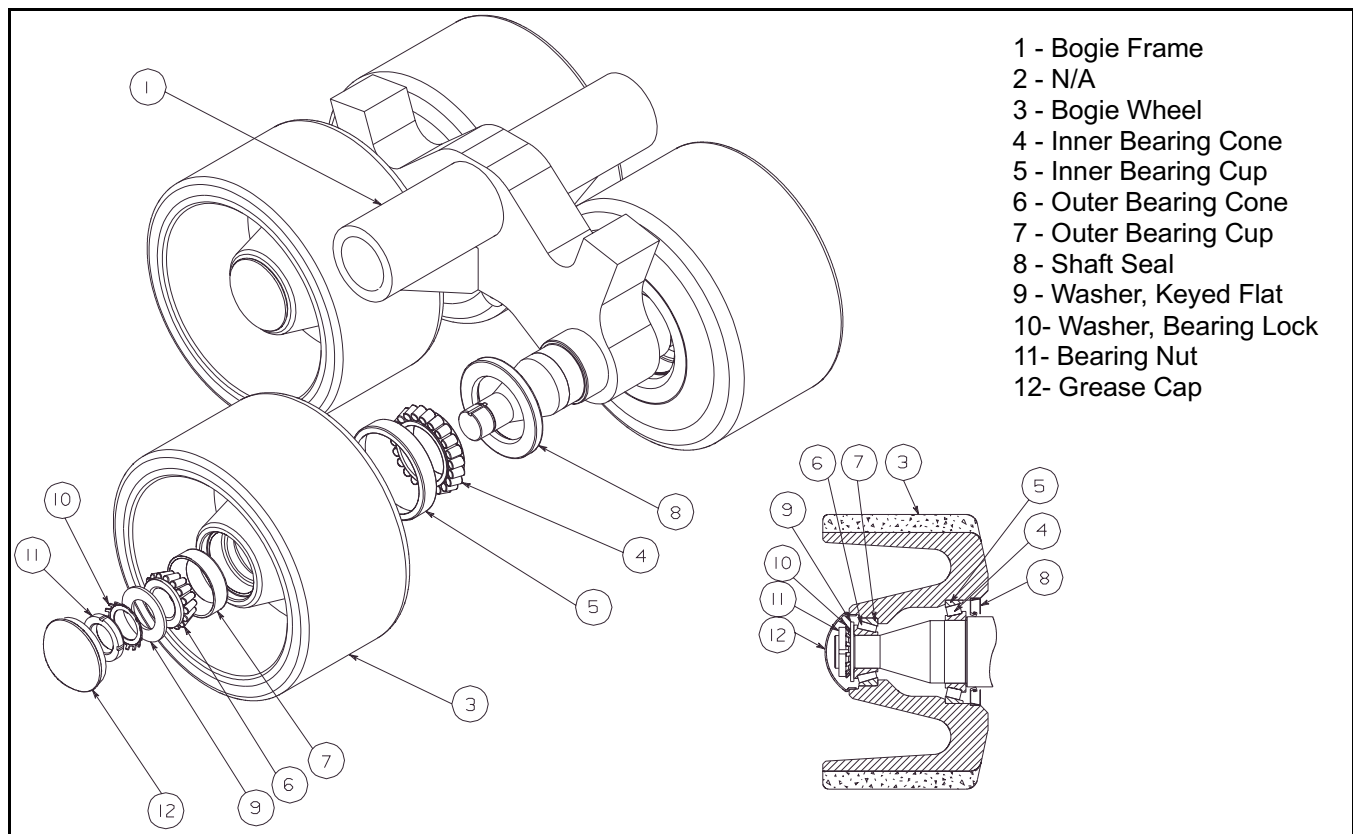

Figure 6 - 18 Bogie Wheel Bearings

Rubber Track Maintenance

Assembly

The following procedure is for establishing the proper bearing setting (.002” - .004” preload) on the bogie wheels. Refer to (Figure 6 - 18):

- 1) Pack inner (4) and outer (6) bearing cones with grease and set aside.
- 2) If inner cup (5) and/or outer cup (7) are to be new, install them at this time by pressing into bogie wheel housing (3) as shown.
- 3) Slide inner cone (4), packed with grease, into the inner cup (5) and then install the shaft seal (8) by pressing into bogie wheel housing (3) as shown.
- 4) Lubricate lip of seal with a small amount of oil or grease.
- 5) Slide bogie wheel onto shaft making sure not to damage lip of seal. This step is best done with the bogie frame (1) turned so the shaft is in a vertical position.
- 6) Pack the cavity between the bearings with grease.
- 7) Slide outer cone (6), packed with grease, onto shaft.
- 8) Slide keyed flat washer (9) and bearing lock washer (10) onto shaft.
- 9) Install bearing nut (11) and tighten to 50 ft/lbs while rotating bogie wheel. This will seat the bearings.
- 10) Loosen bearing nut until it is finger tight.

Note: Take care not to unseat bearings when bearing nut is loosened.

- 11) Tighten bearing nut to 32 ft/lbs while rotating bogie wheel.
- 12) Select one of the locking tabs on the bearing lock washer (10) that is closest to a slot on the bearing nut, and either tighten or loosen nut to align the slot and tab.
- 13) Bend locking tab into slot on bearing nut to lock it in place.
- 14) Install grease cap (12) into bogie wheel housing.

Repeat steps 1 through 14 above for each bogie wheel.

Rubber Track Maintenance

Repairing Rubber Track Front Idler Assembly

The front track idlers, (one on each side), provide the mechanism to maintain tension on the tracks. Each idler assembly consists of two idler wheels bolted to the idler housing, a shaft with tapered roller bearings surrounded by a multi-part frame that acts as a push bar and guide to keep the idler aligned in the track frame. The front idler bearings should not have any end play, but a preload of .001” - .003”.

Front Idler Assembly Removal

To remove front idler assembly from the track frame:

- 1) Perform the procedureSee “Rubber Track Installation & Removal” on page 6. of this section.

Notice - It is necessary to completely remove the track to allow the front idler to be removed from track frame.

- 2) Remove front nose plate pivot retaining bracket (4) from the paver frame.
- 3) Once the track is removed from machine, remove front nose plate (3).
- 4) Remove cam rollers (6) from idler assembly plates.
- 5) The front idler assembly (5) may now be slid forward out of the slots in track frame and lifted from the machine.

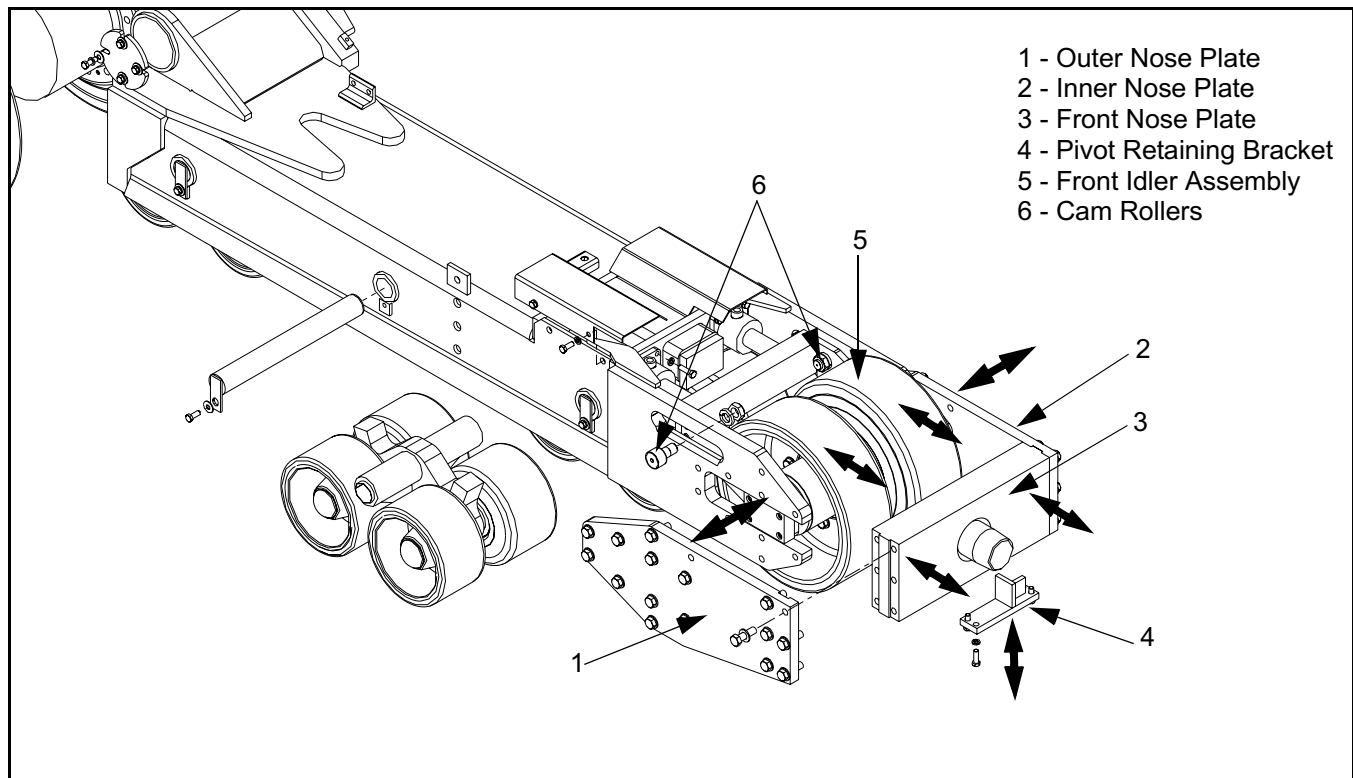

Figure 6 - 19 Front Idler Assembly Removal

Rubber Track Maintenance

Front Idler Assembly Repair

If it is determined that bearing replacement is necessary, proceed with the following:

Disassembly

- 1) Remove front idler assembly as described above. See “Front Idler Assembly Removal” on page 12. of this section.
- 2) Drive roll pins (12) out of slide blocks (6).
- 3) Remove slide blocks (6) from shaft (5).
- 4) Remove and disassemble side plates (2) and (3) from push bar (4).
- 5) Remove bearing caps (8) from each side of idler housing (7). Seals (11) will remain in caps.

Note: If bearings are to be re-used, keep cups and cones in matched sets as originally installed.
- 6) Tap one end of shaft (5) with soft hammer or block of wood to remove bearing cup (10) from the opposite end. Shaft will then come out of idler housing (7) with bearing cones (9) still on shaft.
- 7) Using a punch, remove the remaining bearing cup from the idler housing.
- 8) At this time, if the idler wheels (1) need to be replaced, remove them from idler housing (7) by removing cap screws (16), lock nuts (23), and hardened flat washers (17).
- 9) Clean all parts with mineral spirits solvent, inspect for damage, and replace as necessary.

Rubber Track Maintenance

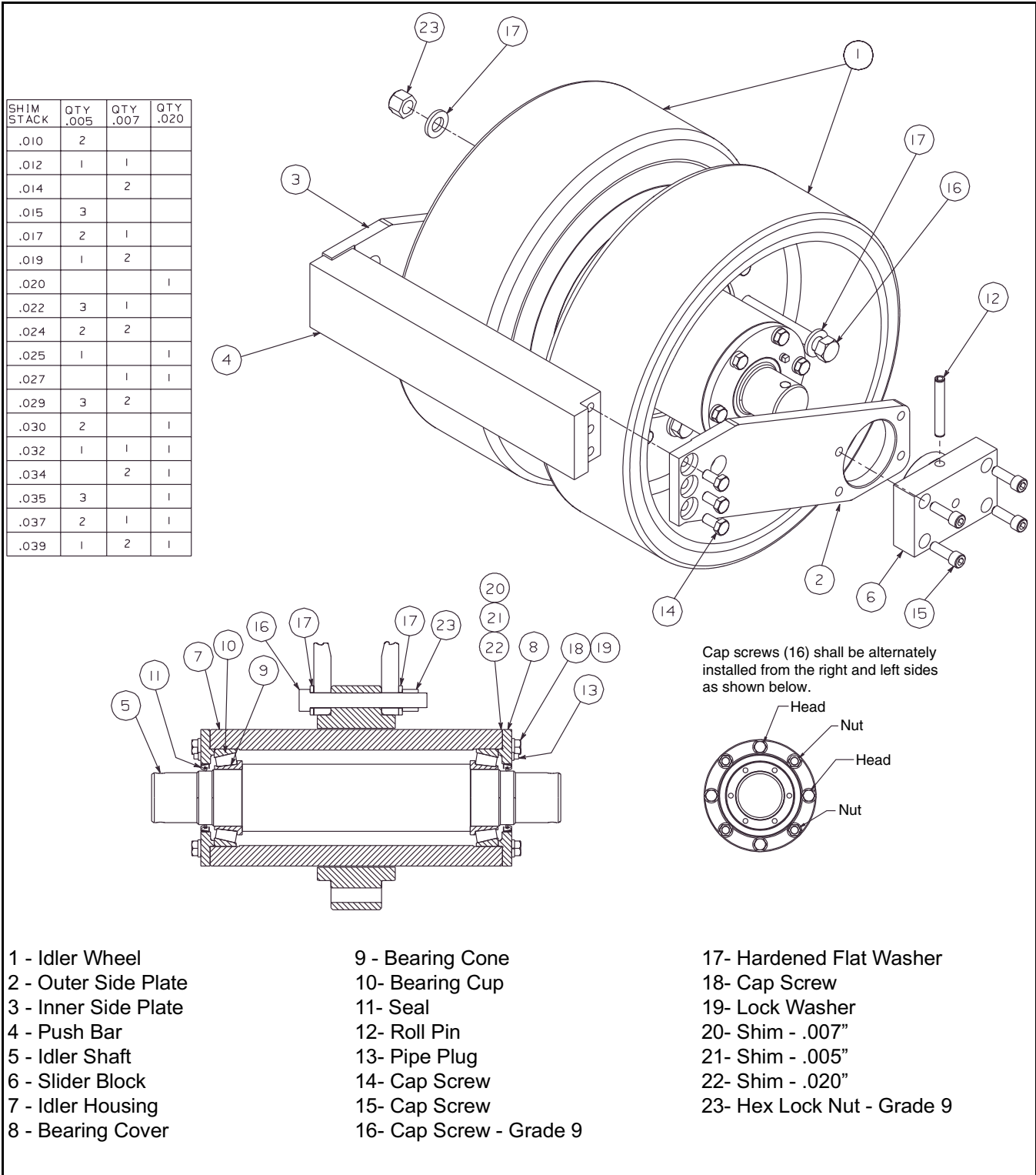

Figure 6 - 20 Front Idler Assembly Repair

Bearing Replacement

Refer to (Figure 6 - 20) and the following procedure:

Note: Use Loctite 272 thread compound on all cap screws.

- 1) Pack bearing cones (9) with grease and set aside.
 - 2) Install new seals (11) into each bearing cap (8) and set aside.
 - 3) Press bearing cones onto shaft (5) and set aside.
 - 4) Press one bearing cup (10) into idler housing.
 - 5) Install one bearing cap (8) onto idler housing and tighten cap screws (18).
 - 6) Slide shaft, with bearings, into idler housing taking care not to damage seal in bearing cap. This step is best done with the idler housing turned so the shaft is inserted in a vertical position.
- Note:** The shaft must be free to rotate.
- 7) Press the other bearing cup into idler housing.
 - 8) Install the other bearing cap with seal (and without shims 20-21-22) onto idler housing.
 - 9) Install two cap screws (18) 180° from each other and tighten in 90° increments. As the two cap screws are tightened, keep the others finger tight to prevent the bearing cap from flexing as it puts pressure on the bearings.

Rubber Track Maintenance

- 10) While turning the shaft with a torque wrench, continue the tightening until a sudden rapid rise in the torque is seen, then stop.
- 11) Measure and record the torque reading as the baseline rolling torque. You will need this reading later.
- 12) Turn the shaft again as above, and continue tightening the two cap screws until a 20 to 55 in/lb increase in rolling torque is achieved.
- 13) Using either a taper gage or a feeler gage, measure and record the gap, in thousandths of an inch, between the bearing cap and the idler housing. Perform this measurement by the two cap screws 180° apart described above.
- 14) Average these two measurements.
Example - One measurement is .022" and the other is .032".
 $.022" + .032" = .054"$ divided by 2 = .027"
.027" is the thickness of shim stack needed.
Refer to the table in (Figure 6 - 20) for combinations to make up the proper thickness shim stack.
- 15) Remove the bearing cap, install the shim stack, and re-assemble tightening all cap screws to specified torques.
- 16) Rotate the shaft, measure and record the rolling torque once again. This torque value should be 20 to 55 in/lb greater than the baseline rolling torque recorded in step 11.
- 17) If this torque value is not achieved, repeat steps 9 through 16.

Rubber Track Maintenance

Assembly

Refer to (Figure 6 - 20) and the following procedure to re-assemble the front idler assembly after bearing replacement:

Note: Use Loctite 272 thread compound on all cap screws unless otherwise noted.

- 1) If idler wheels (1) have been removed from idler housing (7), install cap screws (16) using G-N assembly paste P/N 49999-222, hardened washers (17), and lock nuts (23).

Note: Tighten lock nuts (23) to 250 ft/lb.
Do Not use impact wrench on these nuts.

- 2) Slide side plates (2) and (3) over ends of shaft.
- 3) Install push bar (4) to side plates and leave cap screws (14) finger tight.
- 4) Install slider blocks (6) through side plates and onto shaft (5) aligning each roll pin hole in block with hole in shaft.
- 5) Install roll pins (12) into slider blocks and drive through holes in shaft until flush with edge of blocks.
- 6) Rotate, if necessary, slider blocks to align cap screw holes with holes in side plates.
- 7) Install cap screws (15) and tighten to specified torque.
- 8) Tighten side plate-to-push bar cap screws to specified torque.

Front idler assembly is now ready to be installed back onto track frame.

Front Idler Assembly Installation

Refer to (Figure 6 - 19) and the following procedure to install assembled front idler in track frame:

Note: Use Loctite 272 thread compound on all cap screws.

- 1) Lift front idler assembly and position slider blocks in slots in track frame with push bar toward the rear.
- 2) Slide assembly rearward until holes in side plates line up with slots in track frame.
- 3) Install cam rollers into holes in side plates through slots in track frame and tighten to specified torque.
- 4) Install front nose plate.
- 5) Track may now be installed per See “Rubber Track Installation” on page 8..

Rubber Track Maintenance

Rubber Track Drive Wheel Replacement

When replacement of rubber track drive wheels becomes necessary, use the following procedure:

Removal

- 1) Follow the instructions in Rubber Track Installation & Removal on page 5 of this section for removing the outer drive wheel and track.
- 2) Once outer drive wheel and track are removed, remove the two remaining cap screws which hold the inner drive wheel to the drive motor hub (Figure 6 - 21) and slide wheel off hub.

Installation

- 1) Slide inner drive wheel onto drive motor hub.
- 2) Secure wheel to motor hub with two cap screws 180° apart from each other, use Loctite 272 and torque to 404 ft.-lbs.
- 3) Install track and outer drive wheel per instructions in Rubber Track Installation on page 7 of this section.
- 4) Install remaining drive wheel bolts, use Loctite 272 and torque to 404 ft.-lbs.

Note: Outer drive wheel must be installed with the two larger holes 180° apart from each other aligned and slid over the two cap screws retaining the inner drive wheel.

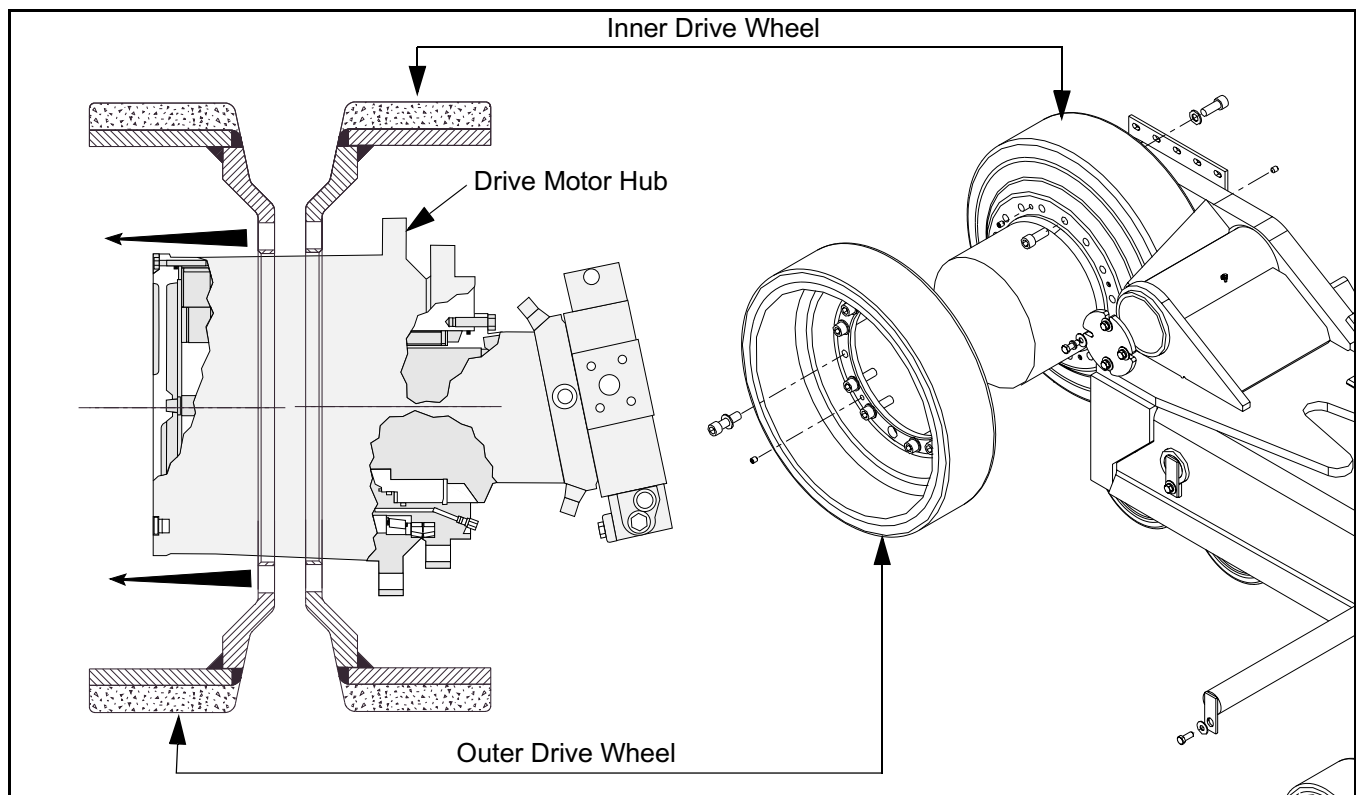

Figure 6 - 21 Drive Wheel Replacement

Delivery Augers

Delivery Augers

Replacing Auger Liners

Liners are bolted to the hopper bed to provide a wearing surface over which the mix is carried. Inspect and replace auger liners as needed.

- 1) Detach screed from tractor. Make sure all electrical cables and hydraulic hoses are disconnected before pulling tractor away (Refer to Screed Section of this manual).
- 2) Elevate the paver to allow an adequate amount of safe working space under the tractor so the liner nuts can be reached. Support the paver with blocking equipment capable of supporting the weight of the paver.
- 3) To replace liners, remove bolts retaining liner panels and slide liners out the back of the paver. New liners can be installed in reverse order. (Figure 6 - 22)

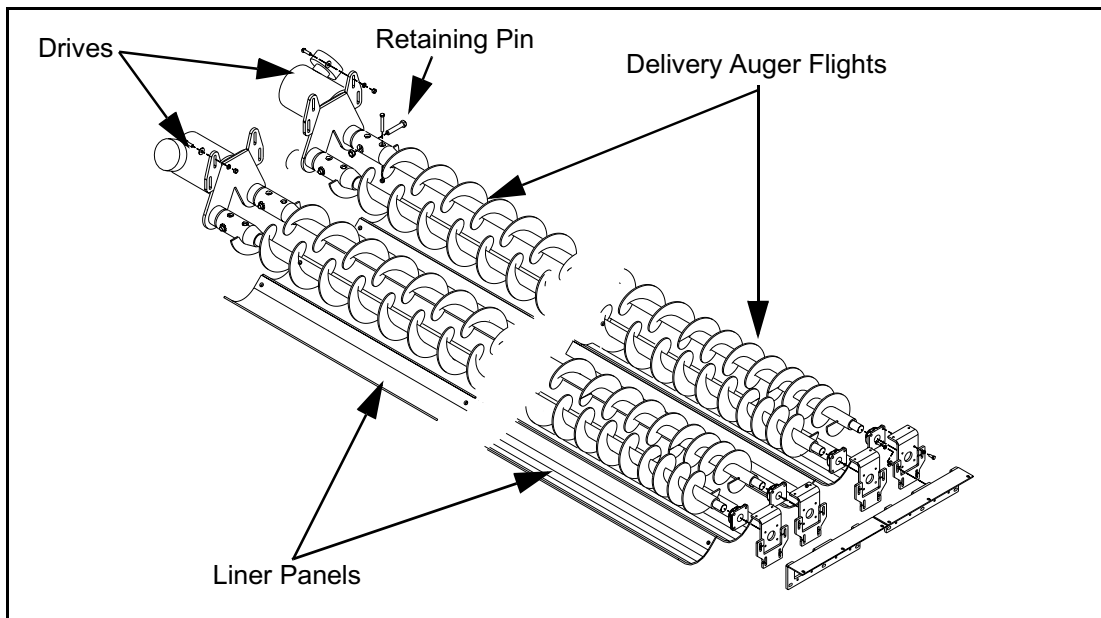

Figure 6 - 22 Replacing Delivery Auger Liners and Flights

Replacing Auger Flights

Worn or damaged auger flights will require either the complete auger replacement by removing from the paver or installation of a field repair kit consisting of one pitch of 10" diameter auger flight. The field repair kit is only for repairing flight at the discharge end of the auger. Separate kits for right and left pitch augers must be used.

Spreading Augers

Spreading Augers

Cast Augers

Current Grayhound pavers are equipped with cast auger sections. Cast augers provide long service life without the need to resurface the augers as they wear. When the augers are worn, replace the auger sections with new bolt-on sections. (Figure 6 - 23)

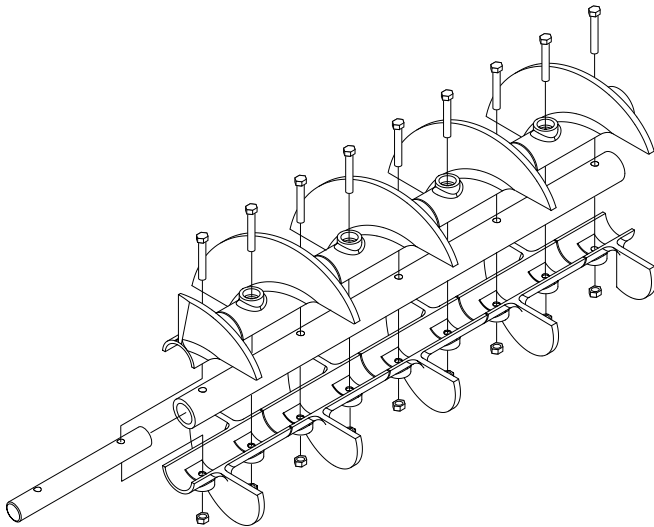

Figure 6 - 23 Replacing cast auger sections

Machine Storage Preparation

Machine Storage Preparation

The following procedures are recommended for conditioning the Cedarapids paver for storage.

- 1) Run all material completely out of the machine.
- 2) Thoroughly clean the complete machine to remove all asphalt.
- 3) Park machine in a shed or well drained area. (Preferably on boards to keep tires or tracks out of mud or standing water.)
- 4) Perform Periodical Maintenance items listed on the periodic maintenance chart found in this manual.
- 5) Thoroughly grease all bearings and bushings. Grease all adjustment bolts on paver and screed.
- 6) Winterize radiator with Anti-freeze to 40° below zero.
- 7) Hang screed on safety cables and retract all hydraulic cylinders so cylinder rods are not exposed.
- 8) Remove batteries, feed controllers and grade/slope controllers. Store in heated area. Store batteries on wood, not concrete.
- 9) Be sure all panel lids and covers are in place. Close tightly to prevent water entry. (Tape around electric panel door to seal).
- 10) Enclose consoles in protective cover. Leave bottom of wrap open to prevent condensation inside. Cover exhaust.
- 11) Remove all books and literature from tool boxes and store inside office or with other stored components.
- 12) Refer to engine manufacturer's specifications for protection of engine.

Torque Charts

Appendix A - Torque Specs

Torque Charts

The following pages contain charts for use as guides when tightening bolts and nuts. These specifications should be followed unless specific torques are given elsewhere in this manual.

Standard Torque Chart

Table A - 1 is a list of recommended torque values for standard bolts. Use this torque chart to avoid overstressing standard nuts and bolts used on Cedarapids equipment. These specifications should be followed unless specific torques are given. Cedarapids uses Grades 2, 5, and 8. The maximum torque values are based on 75% of the specified minimum proof strength of the bolt steel in order to provide a safety factor. The term “lube” applies to cadmium plating and/or application of thread lubricants. Hardened washers should always be used, regardless of whether standard nuts or lock nuts are employed.

Metric Torque Chart

Table A - 2 is a list of torque values recommended for metric bolts. The maximum torque values are based on 75% of the specified minimum proof strength. The term “lube” includes the application of thread lubricants, cadmium plating and the use of hardened washers regardless of whether standard or lock nuts are used.

Torque Charts

		S.A.E Grade 2			S.A.E Grade 5			S.A.E Grade 8		
dia. (inches)	pitch (thread/in.)	Torque (ft-lbs)		Clamp Load (lbs)	Torque (ft-lbs)		Clamp Load (lbs)	Torque (ft-lbs)		Clamp Load (lbs)
		Dry	Lube		Dry	Lube		Dry	Lube	
1/4	20	5	4	1310	8	6	2020	12	9	2860
1/4	28	6	5	1500	10	7	2320	14	11	3270
5/16	18	11	9	2160	17	13	3340	25	19	4710
5/16	24	12	10	2390	19	15	3690	27	21	5220
3/8	16	20	15	3190	31	24	4940	44	34	6970
3/8	24	23	17	3620	35	27	5590	49	38	7900
7/16	14	32	25	4380	49	38	6770	70	54	9560
7/16	20	36	27	4890	55	42	7560	78	60	10680
1/2	13	49	38	5850	75	58	9040	106	82	12770
1/2	20	55	42	6590	85	65	10190	120	92	14390
9/16	12	70	54	7500	109	84	11600	150	115	16380
9/16	18	79	60	8370	121	93	12940	170	130	18270
5/8	11	97	75	9320	150	115	14400	210	160	20340
5/8	18	110	85	10560	170	130	16320	240	180	23040
3/4	10	170	130	13770	265	200	21290	375	285	30060
3/4	16	190	145	15380	295	225	23770	415	320	33570
7/8	9	165	125	11430	425	330	29450	605	465	41580
7/8	14	180	140	12590	470	360	32440	665	510	45810
1	8	245	190	14990	640	495	38630	905	695	54540
1	14	270	210	16400	700	540	42260	990	765	59670
1-1/8	7	350	270	18880	790	610	42340	1285	990	68670
1-1/8	12	395	305	21180	890	685	47500	1440	1110	77040
1-1/4	7	495	380	23980	1120	860	53770	1815	1395	87210
1-1/4	12	550	425	26550	1240	950	59550	2010	1545	96570
1-3/8	6	655	500	28580	1465	1130	64100	2380	1830	103950
1-3/8	12	745	570	32540	1670	1285	72980	2710	2085	118350
1-1/2	6	865	665	34770	1945	1495	77970	3160	2430	126450
1-1/2	12	975	750	39120	2190	1685	87740	3555	2735	142290
1-3/4	5	1370	1055	47020	2285	1755	78370	4985	3835	170990
2	4.5	2060	1585	61870	3435	2640	103120	7500	5765	225000
2-1/4	4.5	3015	2320	80430	5025	3865	134060	10960	8435	292500
2-1/2	4	4125	3170	99000	6875	5285	165000	15000	11530	360000
2-3/4	4	5590	4300	122010	9320	7165	203360	17790	13680	388230
3	4	7385	5680	147750	12310	9470	246260	23500	18080	470130

Table A - 1: Torque Values for Standard Hardware



Torque Charts

dia (mm)	pitch (mm)	Property Class = 8.8				Property Class = 10.9				Property Class = 12.9			
		Dry		Lube		Dry		Lube		Dry		Lube	
		(ft-lbs)	N-M	(ft-lbs)	N-M	(ft-lbs)	N-M	(ft-lbs)	N-M	(ft-lbs)	N-M	(ft-lbs)	N-M
10	1.5	37	50	29	39	53	72	41	56	62	84	48	65
10	1.25	39	53	30	41	56	76	43	58	66	89	51	69
12	1.75	65	88	50	68	93	126	71	96	109	148	83	113
12	1.25	71	96	55	75	101	137	78	106	119	161	91	123
14	2	104	141	80	108	148	201	114	155	173	235	133	180
14	1.5	112	152	86	117	160	217	123	167	187	254	144	195
16	2	161	218	124	168	230	312	177	240	269	365	207	280
16	1.5	172	233	132	179	246	334	189	256	287	389	221	300
18	2.50	230	312	177	240	318	431	245	332	372	504	286	388
18	1.5	258	350	199	270	357	484	275	348	418	567	321	435
20	2.5	325	441	250	339	450	610	346	469	525	712	404	548
20	1.5	360	488	277	376	499	677	384	521	583	791	448	607
22	2.5	443	601	341	462	613	831	471	639	716	971	551	747
22	1.5	486	659	374	507	673	913	518	702	786	1066	605	820
24	3	562	762	432	586	777	1054	598	811	908	1231	698	946
24	2	612	830	471	639	847	1149	652	884	990	1342	762	1033
27	3	823	1116	633	858	1139	1544	876	1188	1331	1805	1024	1389
27	2	889	1205	683	926	1229	1667	945	1281	1436	1947	1105	1498

Table A - 2: Torque Values for Metric Hardware



Torque Charts

Index

A

air filter 9
air restriction indicator 8
alarm silence 14
alternator 13
auger 1
 delivery 25, 2, 18
 flighting replacement 18, 19
 liner replacement 18
 spreading 27, 9, 19
auger override control 14
auxiliary pump filter 8
auxiliary systems pump 18

B

battery 13
belt, pump drive 19
bogie beam bearings 24
bogie wheel toe-in 24
brake

 control 15

burners 1

C

charge filters 8
CIMA Safety Manual 1
conveyor 1
coolant temperature gauge 16
coolant, engine 11
cooler, hydraulic oil 7
counter rotate switch 16
CR451 9
CR451 Driver's Console - Units Prior to Sept. 1999
9
crown control 22

D

delivery auger 1, 25, 18
 bearings 26
 drive 26
 pumps 2
 speed adjustment 14, 15
 speed control 14
depth cranks 22
differential lock 15
DIN connector 27

drive

 belts 19
 delivery auger 26
 spreading auger 27

E

engine

 coolant 11
 coolant temperature gauge 16
 oil 10
 filter 11
 pressure 14
 pressure gauge 15
 radiator 13
 start switch 15

equipment description 1

extension slope 23

extensions 3

extinguisher 19

F

fan belt 12
fan, engine cooling 13
filter 25

 air 9
 auxiliary pump 8
 charge 8
 engine oil 11
 fuel 5
 hydraulic oil 8

final drive oil 23

fire extinguisher 19

flasher control 14

fluid temperature 1

frame raise 16

 control 15

front wheel bearings 24

fuel 5

 filter 5
 water separator 5

fume recovery system 2, 29

H

hazard levels 2

hood

 raise reservoir 28

Index

raising 1
safety latch 1
hopper control 13
horn 16, 19
hour meter 14
hydraulic
fluid 6
lines 8
oil cooler 7
strike-off 3
hydraulic system 1
troubleshooting 33
I
ID number 3
J
jumper cables
raising hood 1
K
key 15
L
light control 14
lockout/tagout 7
low engine oil pressure indicator 14
M
machine storage preparation 20
maintenance checklist 3
manuals 1
master key 15
match height 23
material flow indicator 13
alarm 14
max paver speed control 16
mix flow indicators 13
N
new equipment 10
O
oil
cooler 7
delivery auger drive 26
engine 10
final drive 23
hood raise reservoir 28
hydraulic 6, 1

pressure gauge 15
spreading auger drive 27
temperature gauge 13
operating principle 1
operator console
CR451 After Sept. 1999 10
CR451 Prior to Sept. 1999 9
CR461 After Sept. 1999 12
CR461 Prior to Sept. 1999 11
pivot bearings 28
P
periodic maintenance 3
permissive start switch 14
pocket paver guide 1
pump
auxiliary 18
delivery auger 2
drive belts 19
spreading auger 9
travel 4
vibrator 17
Q
quality paving guide 1
R
radiator 13
range 14
rear frame compensator control 15
receiving new equipment 10
remix delivery auger control 13
remix paver 1
remote oil cooler 17
Rubber 19
rubber track
check valve & shut-off valve 22
hydraulic schematic 19
hydraulic system components 20
hydraulic system schematic 19
pressure reducing valves 21
repairing bogie wheels 9
repairing front idler assy. 12
take-up valve 24
tensioning cylinders 23
track installation & removal 6

Index

- track tension 6
- track tension accumulator 22
- Rubber Track Hydraulic System 19
- S
- safety 8
- screed assist control 15
- screed extension 3
 - control 15
- screed lift control 15
- screw conveyor 1
- serial number plate 3
- slope beam 28
- slopeable hydraulic strike-off extension 3
- solenoid valve 27
 - override button 27
- speed range control 14
- spreading auger 1, 19
 - bearings 26
 - drive chains 27
 - pumps 9
 - speed adjustment 14, 15
 - speed reducer 27
- starting engine 14, 15, 2
 - See also Permissive start switch
- steer assist 16
- steering bogie alignment 23
- steering linkage 24
- storage preparation 20
- strainer, suction 7, 26
- strike-off 3
- suction strainer 7, 26
- T
- tachometer 14
- tagout 7
- technical manual 1
- temperature gauge
 - engine coolant 16
 - hydraulic oil 13
- throttle 16
- tire
 - changing 15
 - pressure 15
- tow arm nose roller 28
- track
 - rubber track tension 19
 - steel track tension 17
- travel lever 16
 - alignment 6
- travel pumps 4
- travel speed range 14
- travel switch 16
- troubleshooting
 - alternator 13
 - battery 13
 - fume recovery system 29
 - hydraulic system 33
 - solenoid valves 28
- truck hitch 29
- truck hook 13
 - control 13
- V
- valve
 - solenoid 27
 - valve bank assembly 31
- vibrator 22
 - control 15
 - pump 17
- Voltmeter 13
- W
- water separator 5
- wear check guide 1
- wheel
 - bogie toe 24
 - front bogie alignment 23
 - front wheel bearings 24

Index