

# Quality Paving Guide Book

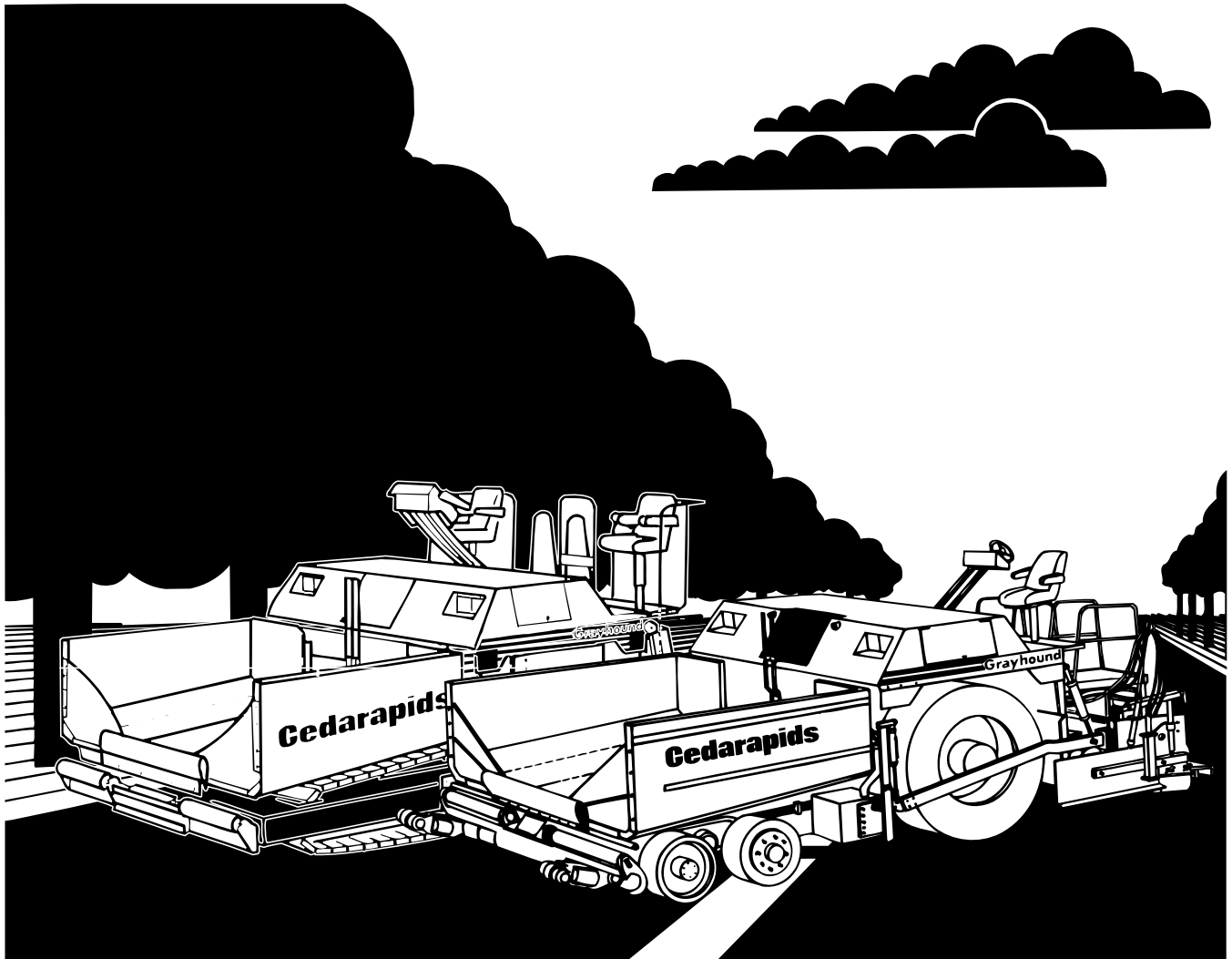



<b>Introduction</b> .....	iii
<b>Basic Functions</b> .....	1
<b>Self-Leveling &amp; Traction Features</b> .....	2
Rubber-Tire Pavers, Track Pavers	
<b>Material Feed System</b> .....	3
Hoppers, Conveyors, Conveyor Flow Gates, Augers	
<b>Material Feed Sensors</b> .....	4
Limit Switch, Proportional Feed Sensor, Sonic Feed Sensor	
<b>Screed</b> .....	5-8
Screed Tow Points and Tow Arms, Screed Depth Cranks, Main Screed Crown Control, Vibrators, Screed Heaters	
<b>Paving Techniques</b> .....	9
Factors Affecting the Screed	
<b>Paving Speed</b> .....	10
Stopping and Starting Paver	
<b>Screed Assist System</b> .....	12-13
Adjusting Screed Assist, Angle -Of-Attack	
<b>Screed Reaction Time</b> .....	14
<b>Adjusting Mat Thickness (Manual Paving)</b> .....	15
Average Depth Method, Desired Yield Method	
<b>Strike-Offs and Blades</b> .....	16-17
Fixed Strike-Offs, Hydraulic Strike-Offs, Vertical Blades, Screeding Blades	
<b>Line of Pull</b> .....	18
<b>Main Screed Crown</b> .....	19
<b>Head of Material</b> .....	20
<b>Controlling Head of Material</b> .....	21-25
Flow Gates, Spilled Material, Material Feed Sensors, Limit Switch, Limit Switch Setup, Proportional Feed, Proportional Feed Setup, Sonic Feed Control, Sonic Operation, Effect of Heat Waves, End Gate Mounting, End Gate Setup	
<b>Material Design</b> .....	26-28
Gradation of Material Design, Aggregate Size in relation to Paving Depth, Asphalt Content, Temperature of Material	
<b>Rolling (Compaction)</b> .....	29-32
Temperature Effects, Paving Depth, Pre-Leveling Grade, Stopping Roller, Roller Patterns, Vibratory Roller Travel Speed, Checking Unrolled Mat	
<b>Automatic Screed Control</b> .....	33-37
Building Profile, Rideability, Evaluation of Jobs, Basics of Automation, Grade Control, Grade Sensor Deadband, Slope Control, Remote Hand-Held Set Unit, Centering Hand-Held Unit, Slope Deadband, Setting Deadband	
<b>Agetk System Four Settings</b> .....	38-41
Accessing System Four Performance Settings, Operation Checks	
<b>Basic Sensor Principles</b> .....	42
Sensor Positioning	

<b>Areas Of Deviation</b> .....	43-44
Tow Point, Screed, Sensor	
<b>Sensor Location with Respect to Screed Reaction</b> .....	45-49
Effective Length of Tow Arm, Screed Mounting, Grade Control for Joint Matching, Grade Control for Fixed Stringline, Grade Control for a Ski, Types of Skis, Traveling Stringline	
<b>Slope Control System</b> .....	50-52
Sensor Positioning, Building For Rideability, Building For Profile	
<b>Reactions (Combinations of Grade and Slope)</b> .....	53-54
Ski and Slope (forward and rearward), Joint Matcher and Slope (forward and rearward)	
<b>SMOOTHTRAC™ Sonic Averaging System (SAS)</b> .....	55-69
Installation, Assembly, Setup, & Operation	
<b>Slope Conversion Table</b> .....	70
<b>Operation</b> .....	71
Nulling Screed	
<b>Joints</b> .....	72-74
Transverse Joints, Longitudinal Joints, Using Automatics	
<b>Segregation</b> .....	74-75
Segregation before Paver, Segregation in Truck, Segregation Stripe, Pre-Compaction Stripe	
<b>Troubleshooting Guide</b> .....	76-80
<b>Paving Terminology</b> .....	81-82
<b>CIMA Information</b> .....	83-89
Asphalt Paver Component Nomenclature List, Rubber-Tire and Crawler Paver Diagrams	

## Introduction

This information should provide a clear understanding of equipment construction, function, capabilities and requirements.

The information is based on the knowledge and experience of highly qualified people at Cedarapids Inc. Proper use of this information will promote high efficiency, maximum service life and low maintenance costs.

The information contained in this manual should not be considered all-inclusive for every application. Questions about specific uses of this equipment should be directed to Cedarapids Inc.

Using this equipment for any purpose other than its intended use assumes the risk of any danger in doing so.

Respectfully,  
Cedarapids Inc.

## SAFETY INSTRUCTIONS

Federal, state and local safety regulations **must** be complied with to prevent possible danger to person(s) or property from accidents or harmful exposure.

This equipment **must** be used in accordance with all operation and maintenance instructions.

We strongly recommend that all persons involved with this equipment be familiar with this manual, operation and maintenance manual and all related engine manuals.

- Read all warning, caution and instruction signs.
- Know what guards and protective devices are included and see that each is used. Additional guards and protective devices that may be required due to the various paver configurations **must be** installed by the user (owner) before operating.
- **Install all** auger guards and vibrator covers **before** operating the paver.
- **Never** attempt to install or remove any part or assembly when the paver is running.
- Wear a protective mask when harmful air pollution exists.
- Wear clothing that fits snug to prevent getting caught in moving parts. Loose-fitting clothing should not be worn.
- Wear safety goggles, gloves and long-sleeve shirts when in close proximity of hot asphalt materials.
- Wear ear plugs if needed.
- Mount and dismount the paver from the rear using only the steps, handrails and walkways provided.
- Allow the **operator only** on the operator's platform when the paver is in operation.
- Before starting the paver, make sure the brakes are in the **ON** position, all other systems are in the **OFF** position and all personnel are clear of the paver.
- Allow the **operator only** on the paver when traveling or roading.

- Before leaving the operator's seat always place the brake switch **ON** and all other controls and switches in the **OFF** or **NEUTRAL** position.
- Reduce travel speed when going down steep grades to prevent over-speeding.
- Keep operator's platform, steps and screed walkways clear of all obstructions (tools, lunch boxes, rakes, shovels, etc. to prevent tripping or falling.
- Keep all personnel clear of paver when operating.
- **Do not** allow personnel near the hopper area when the paver running.
- **Do not** allow personnel to walk between the paver and truck.
- To prevent injuries, screed safety cables and additional blocking beneath the screed **must be used** before any checks or adjustments are made.
- Keep all personnel clear of augers and screed when the paver is operating.
- **Do not** refuel the paver with the engine or screed heater system running. All sparks and open flames **must be** kept a minimum of 50 feet away from the paver when refueling.
- **Do not** wash or spray down the screed with the screed heater system operating.
- To prevent fire hazards, keep the basket area of the tractor free of oil, fuel and trash buildup.
- To prevent fire hazards, keep the screed free of oil, asphalt and trash buildup to prevent fire hazards.

## Basic Functions

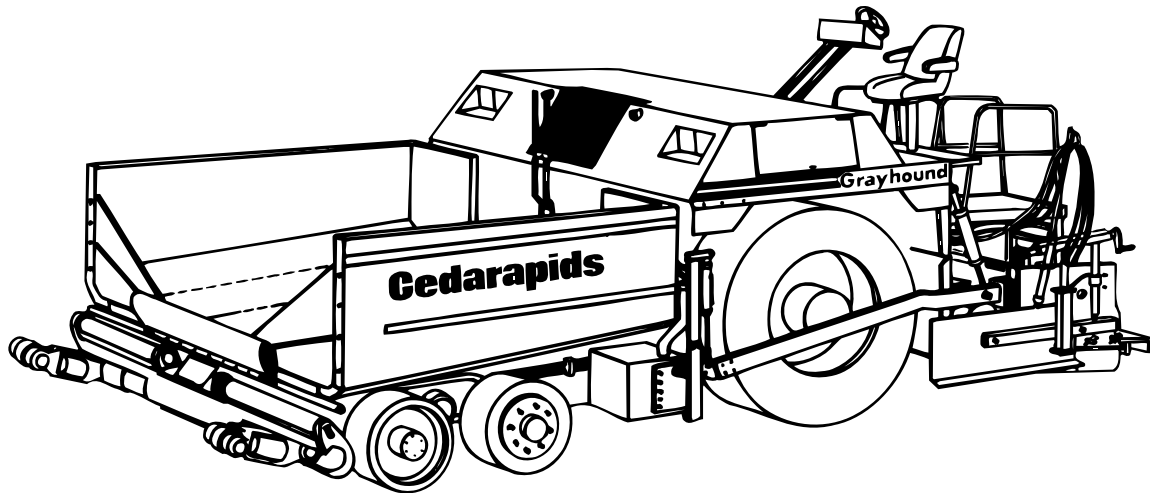
*Figure 1*

The paver's responsibility is to place a given material design over an irregular grade or roadway and meet specifications for approximate grade profile, texture and rideability. An asphalt paver consists of two major components: the tractor and the screed. We will discuss what each component does in a paving operation.

**Tractor**

Rubber tire and track (crawler) pavers are basically the same and perform the same functions in a paving operation.

The track paver is generally used when paving on soft or yielding bases. A track paver provides a high degree of flotation and traction in these base conditions.

The rubber tire paver is generally used on well-compacted base or overlay jobs.

The tractor is self-propelled, utilizing hydraulic pumps and motors to tow the screed.

Other functions such as feeder systems, auxiliary and vibrator systems are also powered by the tractor. Each system is addressed to provide an understanding of how they relate to the paving operation.

## Self-Leveling & Traction Features

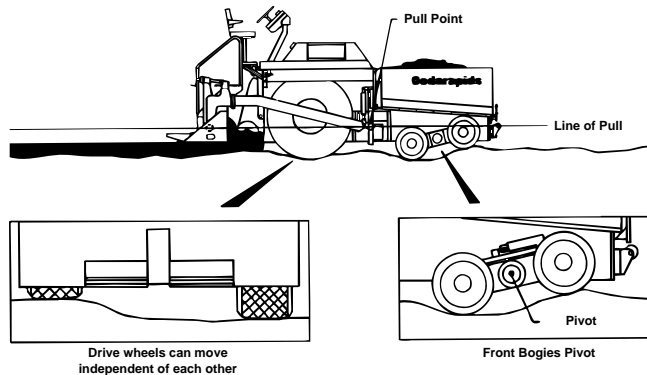

**Figure 2**

The tractor is designed to pave over irregular grades and keep the frame relatively parallel to the line of paving. This self-leveling ability is very important in maintaining a consistent line-of-pull on the screed. The line-of-pull will be discussed in later chapters.

### Rubber-Tire Pavers

A rubber tire paver utilizes a three-point suspension design to allow the tractor to move over irregular grades and maintain a relatively constant line-of-pull on the screed. Severely irregular grade conditions will cause a change in the line-of-pull to the screed. The degree or amount of tow point change is averaged over the length of the wheel base. The self-leveling action combined with the time it takes a screed to react to changes of the line-of-pull, allow the screed to place material in a constant profile.

As the tractor moves over irregular grades, the front bogies pivot as they pass over irregularities. (Figure 2) This action helps keep the line-of-pull relatively constant. As severe irregularities are encountered and the line-of-pull changes, the actual degree or amount of change at the tow point area is smaller, because it is mounted at center point of the wheel base.

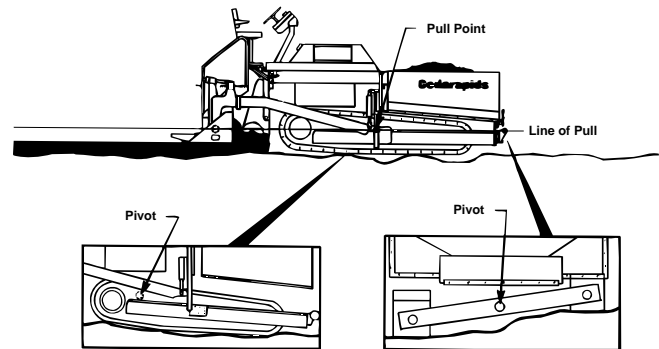

**Figure 3**

The independently mounted rear drive tires conform to ground profile. The line-of-pull is stabilized from front to rear and side to side. Tractive effort is dramatically increased because the wheel load is equal in most conditions.

The operator can reconfigure the frame raise if traction problems occur. Mat problems that would have been introduced due to poor traction are controlled.

### Track Pavers

A track paver utilizes a three-point suspension design to allow the tractor to move over irregular grades and maintain a relatively constant line-of-pull on the screed. Severely irregular grade conditions will cause a change in the line-of-pull to the screed. The degree or amount of tow point change is averaged over the length of the track. The self-leveling action, combined with the time it takes a screed to react to changes of the line-of-pull, allow the screed to place material in a fairly constant profile.

As the tractor moves over irregular grades several things are happening. First the tracks and roller will conform to the grade to help keep the line-of-pull relatively constant. Then the track frames pivot to allow for irregularities from side to side. The frame pivoting action further enhances the tractor's ability to maintain a constant line-of-pull. (Figure 3)

## Material Feed System

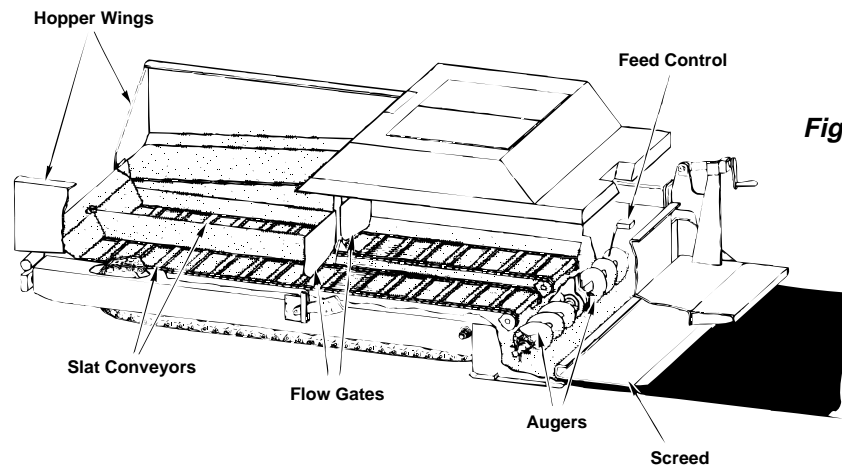

Figure 4

The material feed system plays a very important part in producing constant, high-quality mats. The feeder system consists of FIVE sub-systems. (Figure 4) A good understanding of how they function in relation to each other and their relationship to mat quality cannot be over-emphasized.

### Hoppers

The hoppers are a storage area for material being delivered to the paver by truck or windrow elevator. The hopper capacity will compensate for the fluctuating material demands encountered when paving over irregular grades and will help allow for a more constant paving speed to be maintained.

The hopper wings can be folded upward to use the material that collects in the corners. Mounted at the front of the hoppers is the hopper flashing. The flashing helps prevent spillage of materials from the hopper. It may be necessary to change the flashing to match the configuration of the trucks used.

### Conveyors

The left and right conveyors consist of heavy chains and flight bars. They are driven by separate hydraulic pumps and motors and move material from the hopper through the feeder tunnels to the left and right augers independently. Thus the varying material demands from left to right can be maintained.

### Conveyor Flow Gates

The left and right conveyor flow gates control the amount of material being moved from the hopper to the augers. They can be raised or lowered independently to control the head of material in front

of the screed and match varying material demands from left to right sides of the screed, as irregular grades are paved. The operator can quickly change the flow gates to match changing material demands by simply moving the left or right control switches located on the operator control console. We will discuss how to set the flow gates for different applications and conditions in later chapters.

### Augers

The left and right augers are connected to left and right conveyors. The conveyor and auger systems operate independently. The augers take the material being delivered by the conveyors and move it outward across the width of the screed.

The augers have reversing paddles mounted in the inboard side. (Figure 5) These reversing paddles help fill in the void area underneath the auger conveyor drive box. Two types of augers are used, lined and standard.

**Lined** augers have Ni-hard flight and shaft liners attached to the auger for heavy-duty use and are abrasion resistant. **Standard** augers have a hard facing stripe on the outer edge of the flights for lighter duty applications.

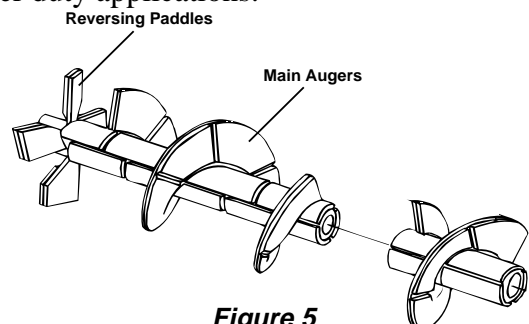

Figure 5

Material Feed Sensors

The operator has the option to run the left or right auger conveyor system in manual or automatic mode. When in automatic mode, the feed sensor on that side will control the level of material on the outboard end of the auger. By setting the position and height of the feed sensor and working in conjunction with the flow gate setting, the head of material can be maintained at a constant level. Cedarapids uses three types of material feed sensors in various models of pavers: limit switch, proportional and sonic.

**Limit Switch Feed Sensor**

The limit switch system turns the auger conveyor system off and on as the level of material raises or lowers. It uses a mechanical wand that floats on top of the material and rotates the limit switch shaft as the level changes. (Figure 6)

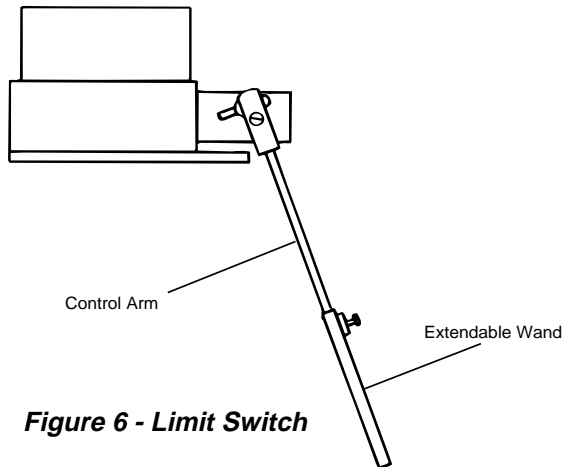

Figure 6 - Limit Switch

**Proportional Feed Sensor**

The proportional system will vary the speed of the auger conveyor system in relation to the rotation of the sensor wand. As the level of material rises and falls, the speed of the auger conveyor system will increase or decrease to maintain a constant level and uniform flow of material across the width of the screed. (Figure 7)

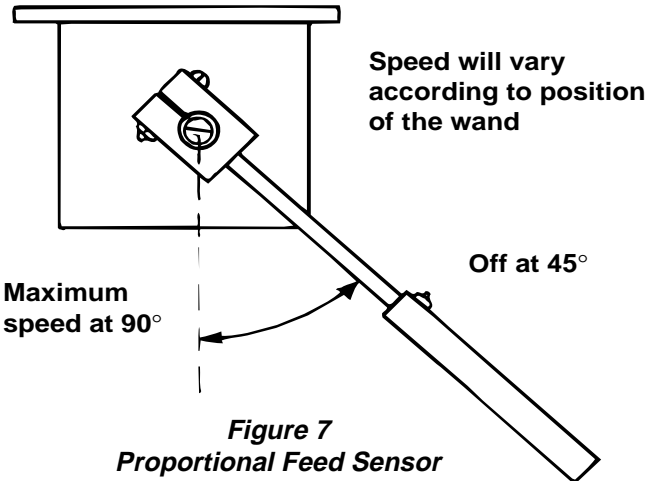

Figure 7  
Proportional Feed Sensor

**Sonic Feed Sensor**

The sonic feed system uses reflected sound waves to sense the level of material. It sends out short ultrasonic pulses several times a second. A timing circuit is started when the pulse is sent out and is stopped when the first echo is received. The length of time between sending the pulse and receiving the echo is used to calculate the distance to the material being sensed. The controller then proportionally varies the speed of the auger conveyor system to maintain a constant level and uniform flow of material across the width of the screed. (Figure 8)

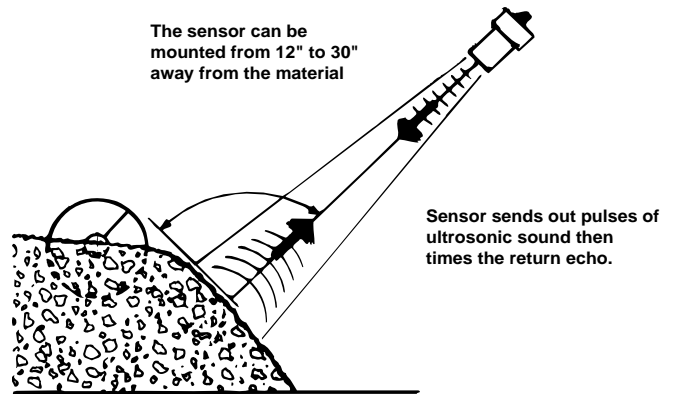

Figure 8  
Sonic Feed Sensor

## Screed

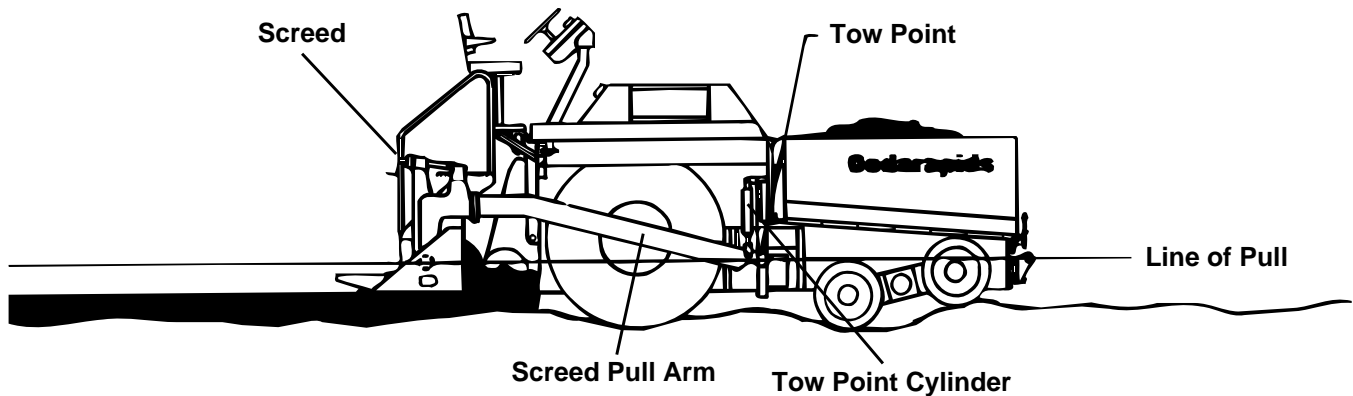

Figure 9

All Cedarapids pavers employ a free-floating screed design. The screed can be thought of as a completely separate machine that is towed behind the tractor and free to float up or down independently of the tractor. It is attached to the tractor by two screed arms that connect at the center of the tractor on each side. (Figure 9)

Where the pull arms connect is called the tow point. The two screed lift cylinders attached to the screed raise the screed for transport. They are placed in a float mode when paving and do not restrict the screed from moving independently of the tractor. By introducing a slight nose-up attitude to the screed or angle-of-attack and towing the screed forward with a constant level of material or head of material in front of it, the screed will climb to a point where it will establish a fixed depth. At this point the screed is floating on the material, much as a boat and skier float on water.

A very important concept of an asphalt screed is its ability to resist immediate changes of depth and slope, caused by outside factors like material design, temperature or human error. This ability is called

**averaging.** As changes are introduced, the screed will average the change over a longer area, thus producing a surface that meets the approximate specifications for profile, depth and rideability.

Some specifications conflict with smoothness. Tolerances for depth of material and yield is an example where specifications and smoothness conflict. The only way to produce a smooth surface is place more material in the depressions and less on the humps. This concept is usually mentioned in connection with paving, but seldom followed. All too often we fall into the trap of placing too much influence on depth in a given area, instead of controlling the average thickness over the entire area.

There are many different factors that can adversely affect the paving operation. These range from production of the aggregates at the pit or quarry, to the last rolling operation on the job. We will discuss all of these factors in later chapters to see how they effect the paving operation and how they are controlled.

The two hydraulic cylinders located at the tow point are used when automatic grade and slope controls are employed. They can also be used to make minor adjustments to the depth or thickness of the mat when paving manually.

## Screed

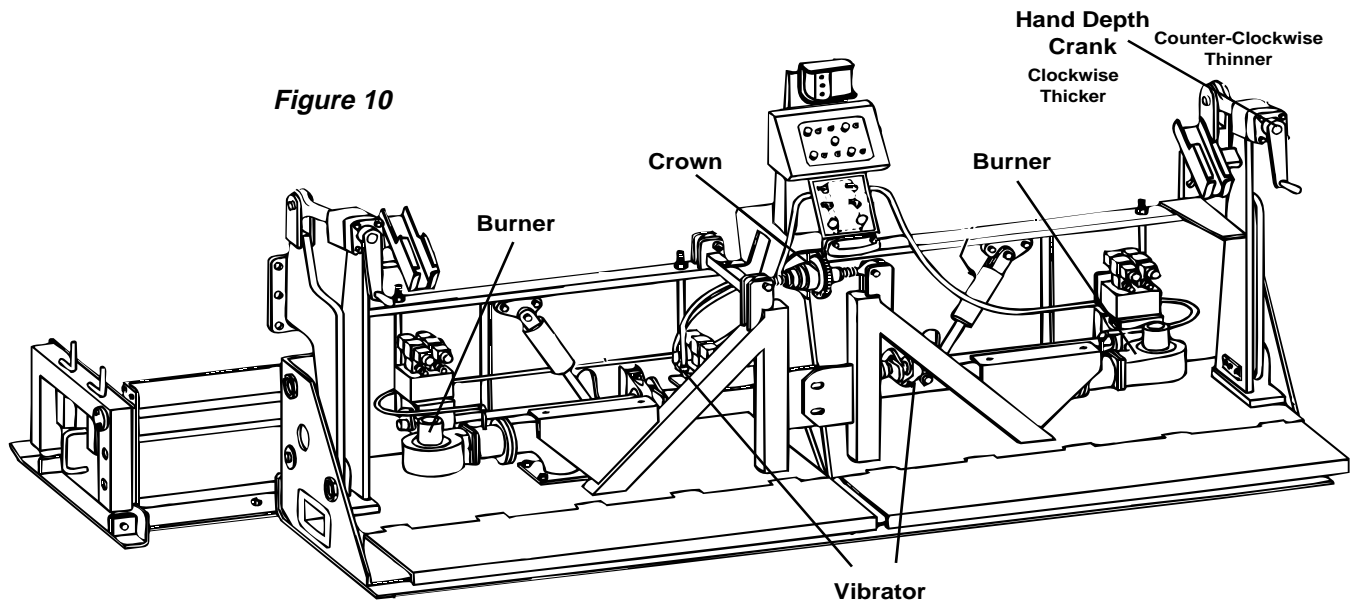

*Optional hand cranks are available for those that prefer turning the hand crank counterclockwise to increase depth.*

### Screed Tow Points and Tow Arms

The screed has two tow arms that connect to center point of the tractor or the tow point. Connecting at the center point of the tractor enhances the performance of the screed, by maintaining a consistent line-of-pull. When paving over irregular grades, the tractor can pivot much like a seesaw without changing the line-of-pull. If the irregularities are such that the line-of-pull is changed, the actual amount of change to the screed angle-of-attack is minimal, due to the length of the tow arm.

### Screed Depth Cranks

The screed depth cranks are the primary means that set the desired depth of material being placed on the grade. (Figure 10) As the hand crank is turned clockwise, the angle of the screed bottom or angle-of-attack in relation to the grade is increased, causing the screed to climb to a new thicker depth. If the hand crank is turned counterclockwise, the angle of the screed bottom or angle-of-attack in relation to the grade is decreased, causing the screed to go down to a new thinner depth. Only small adjustments should be introduced and the results checked, as the screed does not react immediately to the full amount of the change that was introduced. Refer to Screed Reaction Time for an explanation of how quickly the screed reacts to given changes.

Screed

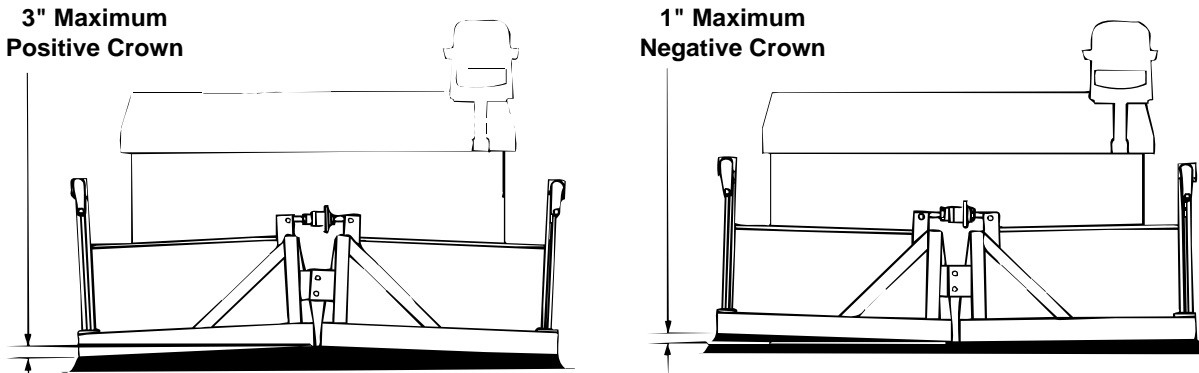

Figure 11

**Main Screed Crown Control**

The main screed crown control allows the screed bottom to be set to a flat profile, or be bent to match specifications for various road profiles. The crown can be set from a 1 inch negative to a 3 inch positive crown over 10 feet. (Figure 11)

**Vibrators**

The vibrators mounted on the screed rearrange particles and aggregates in the material being placed so the texture is more uniform. Approximately 80% to 85% of the theoretical maximum density is usually achieved by the screed.

The actual density achieved by a given screed is dependent on: (a) the amount of bearing pressure applied to the material by the screed; (b) mix design;

(c) percent of asphalt; (d) temperature (mix, ground and ambient); (e) depth of material; and (f) grade conditions.

The vibrators can be adjusted for both VPM (vibration-per-minute) and amplitude (amount of force imparted from the screed to the material).

VPM is adjusted by turning a control valve located on the screed. Clockwise rotation increases VPM, while counterclockwise rotation decreases VPM. (Figure 12)

The amplitude is changed by relocating the orientation of the eccentric weights located on the vibrator shaft. (Figure 13)

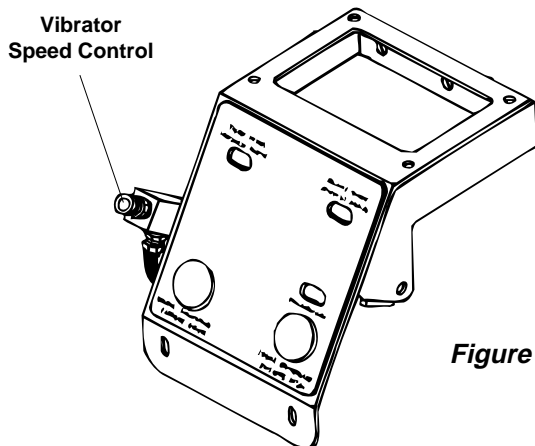

Figure 12

Clockwise rotation of the knob increases VPM.  
Counterclockwise rotation decreases VPM.

**Amplitude Setting**

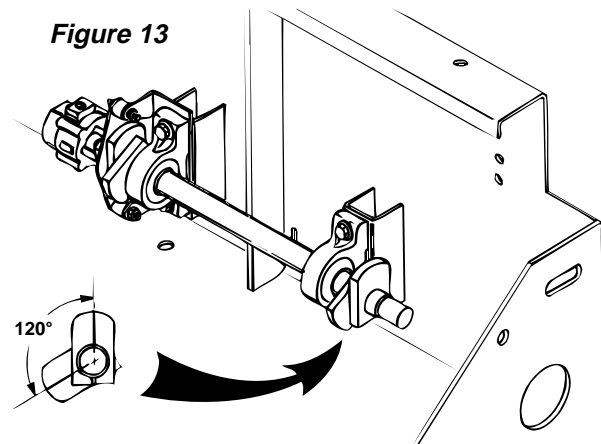

Figure 13

The smaller the angle the higher the amplitude

Screed

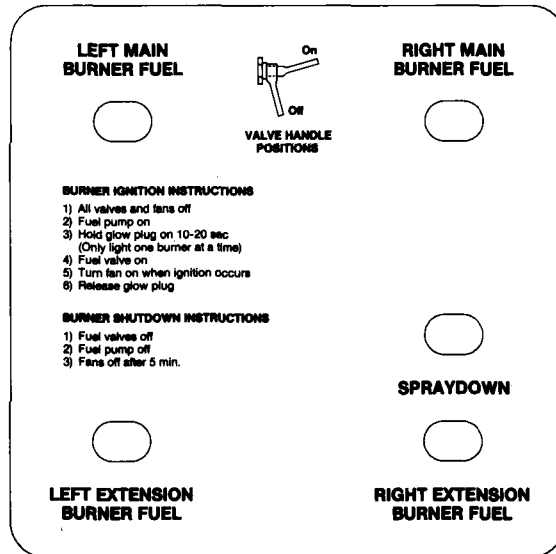

Figure 14

**Screed Heaters (Burners)**

The screed has two or more heaters mounted on it, depending on model. The heaters preheat the screed bottom to the temperature of the material being placed. The screed should be heated before start up or when the screed has been raised out of the mix for an extended period of time.

If the screed is not brought up to the same temperature of the mix, the texture of the mat will appear open and torn. Depth control problems can also be attributed to a cold screed bottom.

A misconception commonly encountered is the heaters can heat up cold material. This is **not true**. Even if the screed bottom is super-heated only the surface materials are warmed up.

If cold materials are encountered, the hot plant output temperature could be increased or covering the truck beds should be considered. If the burners are left on for an extended period of time, the temperature of the surface materials could rise above 325° F, which could damage or destroy the asphalt content. The screed bottoms could also warp if overheated.

Paving Techniques

**Factors Affecting the Screed**

The factors affecting the performance of a paver are not exclusive to the paver but can originate from other sources. We will discuss each of the following factors to provide a good understanding of the effect they can have on producing high quality mats:

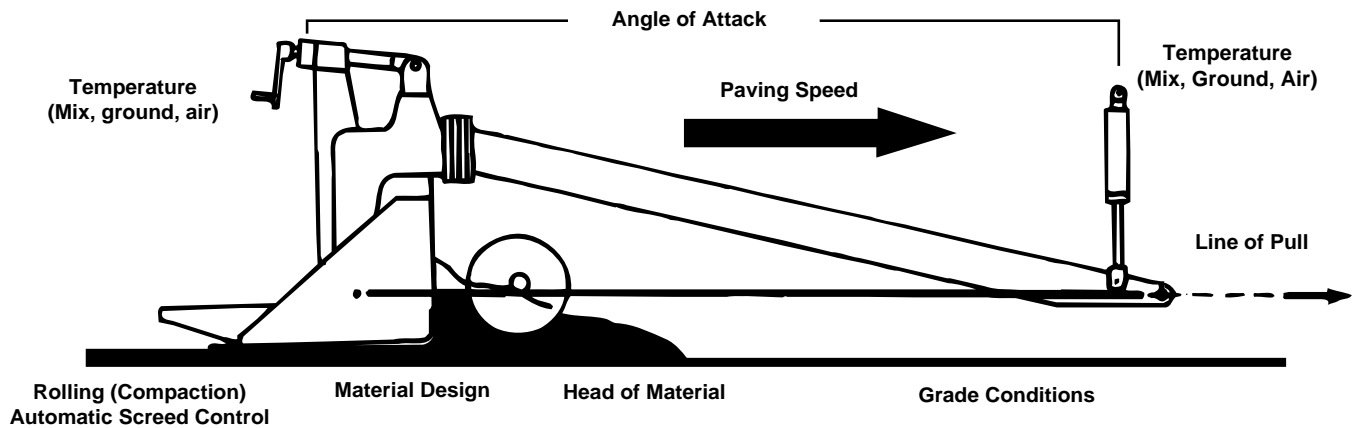

Figure 15

Paving Speed

Approximate Asphalt Tonnage for 1" Compacted Mat in Tons-per-Hour															
Paving Width in Feet															
FPM	6'	7'	8'	9'	10'	11'	12'	13'	14'	15'	16'	17'	18'	19'	20'
10	22	26	29	33	37	40	44	48	51	55	58	62	66	69	73
20	44	51	58	66	73	80	88	95	102	109	116	124	131	139	146
30	66	77	87	99	110	120	131	142	153	164	175	186	197	208	219
40	88	102	116	131	146	161	175	190	204	219	233	248	263	277	291
50	110	128	146	164	183	201	219	238	256	273	291	310	329	347	365
60	131	153	175	197	219	241	263	285	307	328	349	372	394	416	438
70	153	179	204	230	256	281	307	332	358	383	407	434	460	485	511
80	175	204	233	263	292	321	350	380	409	437	466	496	526	555	584
90	197	230	261	296	329	361	394	427	460	492	524	558	591	624	657
100	219	256	291	329	365	402	438	475	511	547	582	620	657	694	731
110	241	281	320	361	402	442	482	522	562	601	640	681	723	763	803
120	263	307	349	394	438	482	526	569	613	655	698	743	788	832	876

*These tonnages are approximate and based on average width, depth, paving speed and density. Specific weights of asphalt mixes will vary. Read the speed of the paver in feet per minute down the left hand column and paving width across the top. Example: At 40 fpm, paving a one-inch, 10-foot wide mat would take approximately 146 tph.*

*For a 1/2-inch mat, multiply the chart figure by 0.5. This example for a 1/2-inch mat would be approximately 73 tph.*

*For a 2-inch mat multiply the chart figure by 2, which in the above example would be approximately 292 tph. The above chart is based on material weighing 146 pounds per cubic foot. If actual material weight is 124 pounds per-cubic-foot, the ratio would be 124 pounds per cubic foot divided by 146 pounds per cubic foot, giving 0.85 of the value shown.*

The contractor must get increased production for every hour worked without loss of quality. So a paver must place every ounce of material delivered to it while maintaining top quality. To do this consistently a few things must be taken into account:

- 1) The tonnage output of the hot plant has to be known. Remember, the output rate can change due to outside factors such as the amount of moisture in the stock pile.
- 2) Take into account the method used to deliver material to the paver. This includes the number of trucks, size of trucks, distance from plant to paver and traffic conditions.
- 3) Know the paving width and depth. Use the chart in this section to calculate the paver speed required to place the material.

## Paving Speed

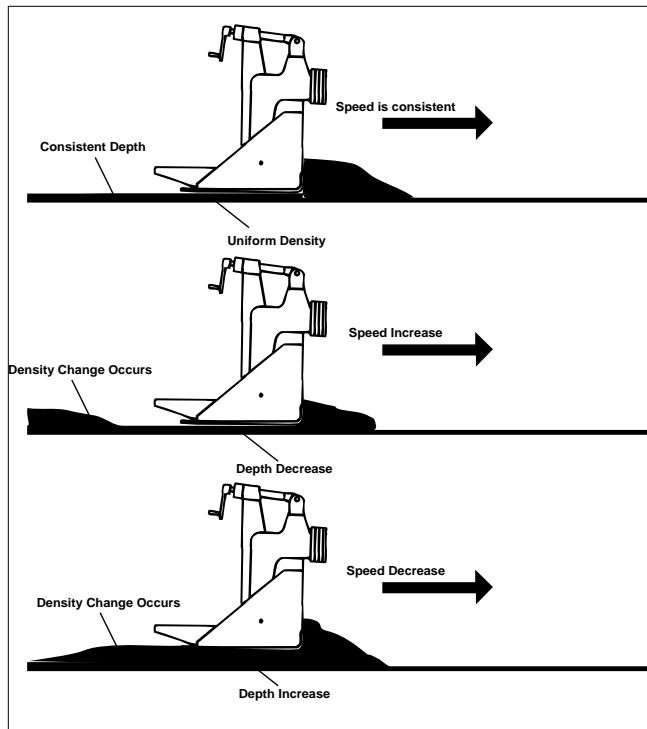

**Figure 16**

The ideal operation is when the paver is moving at a **fixed speed**, a minimum of 80% to 90% of the time and only spending 10% at a lower rate of speed or stopped. Most defects in a mat will occur where a paver is stopped. A higher quality mat will be produced by keeping the paver at a constant speed, limiting stops and amount of time stopped.

When the paving speed is consistent, the amount of shear force is constant and the amount of time the material spends under the screed is uniform. The screed will remain at that given depth.

Assume all factors and conditions are constant and not influencing the screed. **When the paver speed varies, the screed has a tendency to rise and fall.** This is due to the amount of force required for the screed to shear through the head of material and the compaction effort of the screed.

The amount of change in depth introduced by varying the paver speed is dependent on the material design, temperature of the material, paving depth, screed

type and amount or degree of speed change. The amount of change due only to paving speed is very small. The head of material is also dependent or affected by paving speed and will cause changes to occur.

**Increasing** the paver speed will decrease the time the material spends under the screed, therefore changing the equilibrium of the screed. The screed will drop in depth to a point where the equilibrium of the screed is reestablished. (Figure 16)

**Decreasing** the paver speed will increase the time the material spends under the screed, therefore changing the equilibrium of the screed. The screed will climb in depth to a point where the equilibrium of the screed is reestablished.

### Stopping and Starting Paver

It is best to keep the paver moving at a constant rate but it may become necessary to stop the paver during operation. We recommend stopping the paver as quickly as possible, without being erratic in nature.

The same is true of starting the paver. Accelerate as quickly as possible to the previous paving speed. This minimizes any deviation in depth. An increase in depth can occur in the area where the screed stops in certain materials. This change is due primarily to the head of material, temperature of material, screed settling and the friction differences between the material and screed bottom when the screed is stopped or moving.

When a paver is stopped, all screeds tend to settle to some degree depending on material designs. By limiting the number of stops and keeping the paver moving, fewer mat problems will occur. If a paver has to stop for an extended period of time, making a joint should be considered. When stopped for extended periods of time the material temperature in front of the screed and in the hopper drops. This change of temperature will cause a texture change to occur in the mat being placed and also a depth change.

Screed Assist System

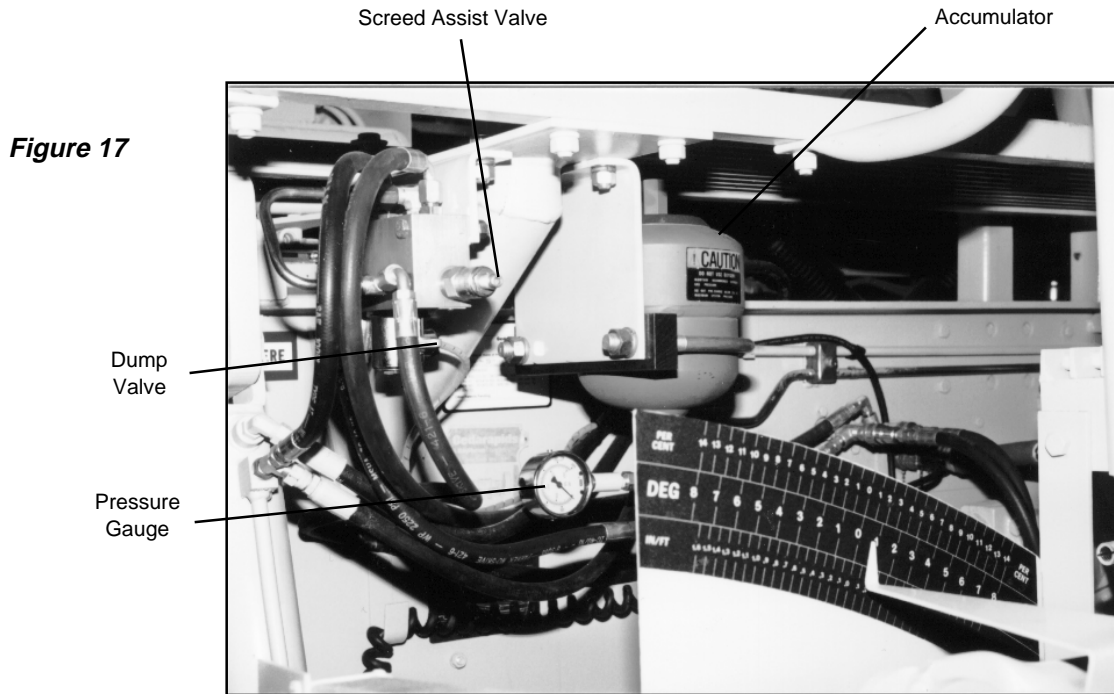

The screed assist system provides a means to adjust the bearing weight of the screed on the material to meet varying material designs and paving widths. By adjusting the system to meet the specific conditions encountered, higher quality mats can be produced. Excessive settling marks traditionally encountered while paving narrow widths and using tender material designs can now be controlled.

**Adjusting Screed Assist**

- 1) Set the screed on the ground. Screed lift switch set to **float**.
- 2) Screed assist switch **on**.
- 3) Loosen jam nut on screed assist adjustor valve. Adjust pressure reading on the gauge to 200 psi.
- 4) Start paving operation as normal after all other operational settings have been set (head of

material, depth, paving speed, material flow gates, automatic screed controls). Note the amount of settling that occurs when the paver is stopped.

- 5) To check if settling is unacceptable, let the lead roller pass over the marked area, one pass forward. If the mark is removed by the first pass of the roller, no further adjustment will be required. (Figure 18)
- 6) If the mark was not totally removed in the first pass, again loosen the jam nut on the adjustor valve and increase the pressure 25 psi while paver is moving. Repeat steps 4 and 5. See if lead roller takes the mark totally out.
- 7) Repeat this procedure until the mark can be totally removed on the first pass of the lead roller.

**A normal settling mark can be rolled completely out by the first pass of the roller.**

**Excessive settline marks cannot be taken out by the first pass of the roller.**

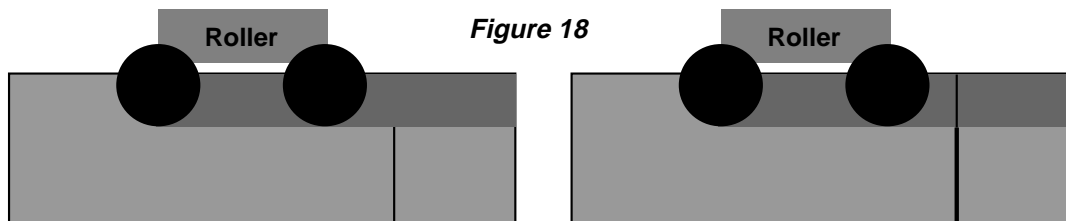

---

 Screed Assist System
 

---

**The Dump Valve should remain closed at all times.** It is provided to dump pressure from the system, so it can be worked on safely by the mechanics.

**Do not** switch the screed assist system **off** and **on** during a paving operation. This will cause mat defects.

**Do not** use any more pressure than required to control settling or the screed may have a tendency to ride on its nose. This could cause other mat problems.

**Rule of Thumb** Higher pressure is required for narrow-width paving (under 12 feet wide), lower pressure is required for wide-width paving (beyond 12 feet wide).

---

 Angle of Attack

The angle-of-attack (or angle of the screed bottom in relation to the grade being paved) controls the depth of material. When a screed has established a given depth on both sides of the screed, the screed is floating on the material with a nose-up attitude or a given angle-of-attack. The angle-of-attack required to produce a given depth is dependent on screed type, material design, material depth and temperature of the material. The angle of the left and right sides of the screed can be set independently of each other to a given degree. This means material depth on the left side of the screed can be different from that being placed by the right. This is done by introducing a twist in the solid screed bottom.

There are two ways to set or control the angle-of-attack:

- 1) The primary means is the left and right screed depth cranks. These are used to establish the desired depth and profile of mat being placed. (Figure 19)
- 2) The tow point cylinders are used to maintain a previously established depth or profile in conjunction with screed automatic grade and or slope controls. They can also be used in a manual mode to make minor corrections to the depth or profile. (Figure 20)

Some other factor of screed settings also affect the angle-of-attack. These are the fixed strike-off setting, hydraulic strike-off type and setting, the line of pull, and the main screed crown setting. Refer to each subject for an explanation of how they can affect the angle-of-attack.

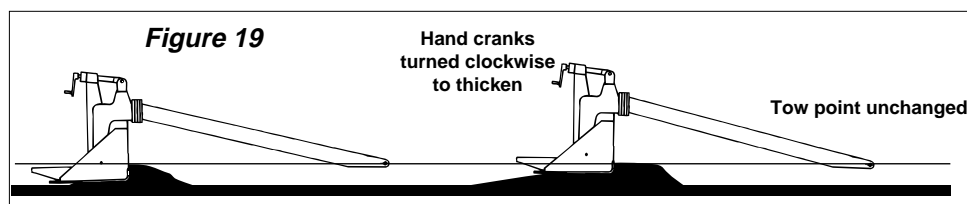

**The tow point is unchanged but the angle-of-attack can be increased or decreased by turning the screed hand cranks. By use of the hand cranks, depth can be varied from 0 to 12 inches.**

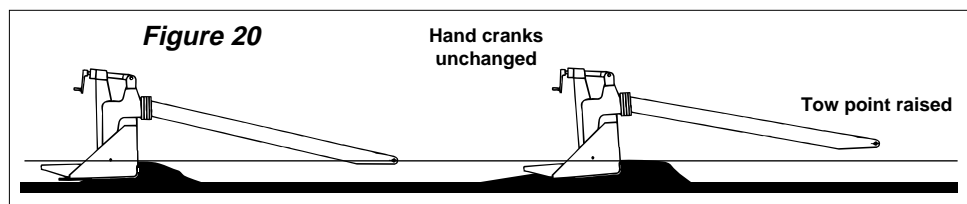

**The hand cranks are unchanged, but the angle-of-attack can be increased or decreased by moving the tow point up or down. By use of the tow point cylinders, depths can be varied up or down from the depth established by the hand cranks. It is important to remember the amount of angle required to produce a given depth will vary due to material design, screed type, depth of material and temperature.**

Screed Reaction Time

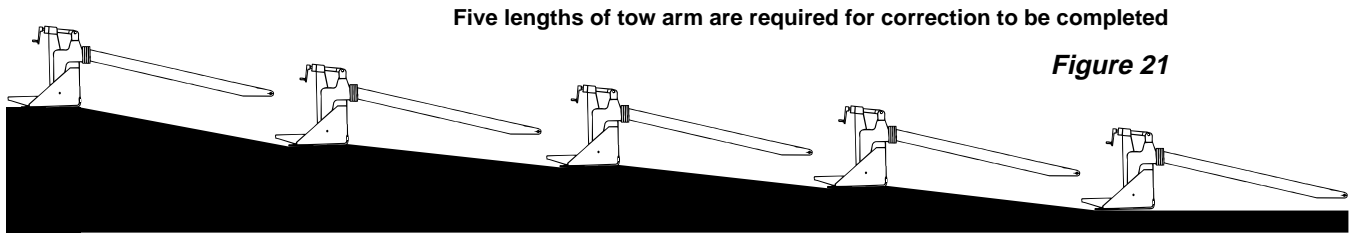

Figure 21

First length 60-65%

The next four lengths the remaining 30 - 35%

Screed reaction time refers to the amount of time required for a screed to complete a change in depth that was introduced by the screed depth cranks or by a change in position of the tow points.

As shown in figure 21, a given downward change was introduced to the angle-of-attack. If no other changes are introduced, the screed will decrease in depth approximately 60% to 65% of the total amount of change in the first length of the tow arm. As the screed travels four more lengths of the tow arm, the remaining 30% to 35% of the total change will occur.

The reason the screed completes 60% to 65% of the total change in the first length of the tow arm and then takes four more lengths of the tow arm to

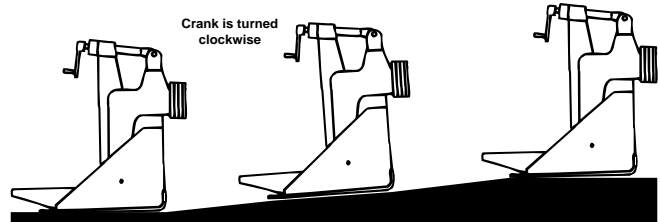

Figure 22

The actual angle-of-attack required for a specific depth is dependent on the material design, temperature of the material, depth of material and screed type. Course, dense material designs will require a smaller angle-of-attack to produce a given depth in comparison to a fine graded or sandy material design. This is due to the compaction rates of the various material designs.

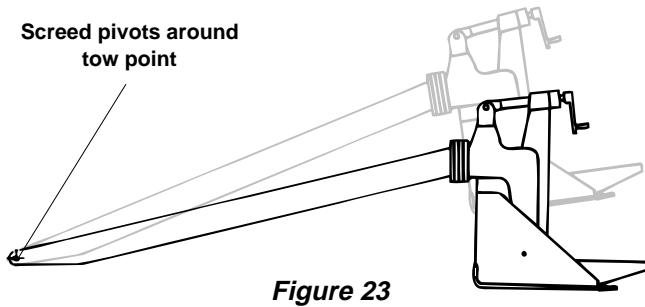

Figure 23

complete the remaining 30% to 35% is because the screed actually pivots around the tow point. (Figure 23) When the angle-of-attack is increased from a given depth, the higher angle-of-attack will allow more material to meter under the screed, causing it to start climbing. As the screed climbs, the new higher angle-of-attack starts decreasing and the amount of material metered under the screed decreases, causing the rate of climb to decrease. The new angle-of-attack established at the end of five lengths of the tow arm will be slightly larger than that required at the thinner depth. (Figure 22)

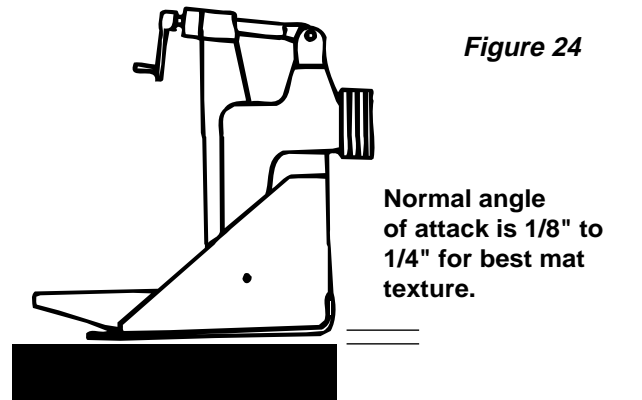

Figure 24

A screed should run with a 1/8 inch to 1/4 inch nose-up attitude or angle-of-attack. (Figure 24) When running in this range the full width of the screed bottom is utilized to produce the best possible mat texture. If the screed is allowed to run at extremes of increased or decreased angle-of-attack, poor mat texture will result. In these conditions, only a small portion of the screed bottom is utilized for compaction and texture, decreasing the life of the screed bottom.

Our objective is to place a smooth, uniform asphalt mat over an irregular grade. When paving manually, we do not have the advantage of screed automation controlling depth adjustments for us. This control is in the hands of the screed operator. He has to evaluate the grade conditions and specifications or requirements of the job. Factors of average depth, yield, profile and slope become a big concern as most manual paving jobs will not allow for more material to be placed than what was estimated or bid on. To be able to place a smooth, uniform mat over irregular grades and control yield, we have to be able to check and control our material usage. There are two ways to do this.

### Average Depth Method

The first method of manual control is to determine the average depth desired and adjust the screed to obtain that depth. The most common means to measure depth employs a depth sticker. Take a minimum of **five checks** about five feet apart and average the checks.

Example: The desired average depth is two inches. Make no corrections to the depth until all five checks have been made. The first check measures  $1\frac{7}{8}$  inches. The second measures  $2\frac{7}{8}$  inches. The third measures  $2\frac{1}{8}$  inches. The fourth measures  $1\frac{3}{4}$  inches. The fifth measures  $1\frac{7}{8}$  inches. All five checks equal  $10\frac{1}{2}$  inches. Divide  $10\frac{1}{2}$  inches by the number of checks (5). This equals approximately  $2\frac{1}{32}$  inches. We are approximately  $\frac{3}{32}$  inch above our desired 2 inch average. The screed has averaged the depth for us. If we would have introduced a change for each check we would only have been mirroring the irregular grade and would not have achieved a uniform coverage and smooth surface.

**Figure 25**

Improper use of a depth sticker creates humps and bumps instead of a smooth uniform surface.

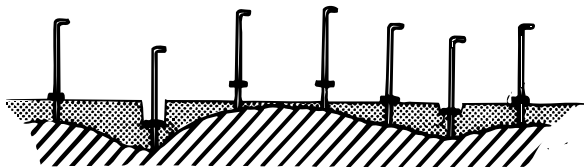

### Adjusting Mat Thickness (Manual Paving)

Figure 25 shows a very important fact about a depth sticker. It shows **only** the thickness of material at one exact point **behind** the screed and **does not** reflect the grade conditions yet to be paved over. **Correct the screed only after multiple checks have determined the average thickness.**

### Desired Yield Method

The second way to control yield is to calculate the desired yield and adjust the screed to conform. To do this, figure out how many linear feet a truckload of material should be capable of paving and then adjust the screed to obtain that yield.

First, determine the compacted weight of the material being placed (in pounds per cubic foot). For this example, assume the material is 144 lbs per cubic ft.

Then, figure the desired depth in *feet*. For example, if the desired depth is 2 inches, and there are 12 inches per foot, this gives 2 inches x (1 ft. per 12 inches), which =  $\frac{2}{12}$  feet deep. Multiply the compacted weight (144 lbs per cubic ft.) by the depth ( $\frac{2}{12}$  ft.) and desired width of the mat (for example, 12 feet).  $144 \times \frac{2}{12} \times 12 = 288$  lbs per foot of travel. The desired yield of a mat 2 inches thick and 12 feet wide is 288 lbs per foot of travel.

Next, find out the weight of the material in an average truck. Assume it is 36,000 lbs. Divide 36,000 by 288 lbs. per ft. and you get 125 linear feet of travel per truckload.  $36,000 \text{ lbs.} / 288 \text{ lbs. per ft. of travel} = 125$  linear feet.

We should be able to pave approximately 125 feet with this truckload of mix. If the yield is high or low, make a **small** adjustment and re-check. Remember, you will never be able to hold a 0 yield factor due to the irregular grades, but you will be able to keep it very close to zero. The important fact is by using this method we are not over-correcting the screed, which causes humps and bumps. Instead we are allowing it to average the material depth for us, which produces uniform coverage and a smooth surface.

## Fixed Strike-offs

The fixed strike-offs act as a material metering device to control the amount of material allowed to pass under the screed, thereby controlling or affecting the angle-of-attack required to produce a given depth. They also absorb wear that would have been introduced to the nose area of the screed bottom. The normal setting of  $\frac{1}{2}$  inch above the screed bottom will work fine in most material designs currently used. (Figure 26) There are material designs that will require changing the setting to allow the screed to run with the desired  $\frac{1}{8}$  inch to  $\frac{1}{4}$  inch nose-up attitude or angle-of-attack.

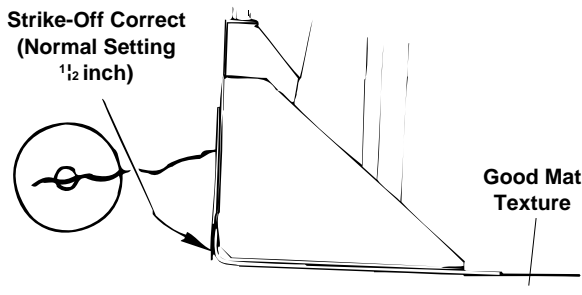

Figure 26

If the fixed strike-offs are set too high for the material design being used, too much material is allowed to pass under the screed. This increased material flow provides unnecessary screed lift or float. To maintain a given depth, the angle-of-attack must be decreased to compensate for increased lift. In this condition the screed is running with a slight nose-down attitude. Only the front portion of the screed is compacting and finishing the material being placed. Poor mat texture occurs and extreme wear is introduced to the nose area of the screed bottom. (Figure 27)

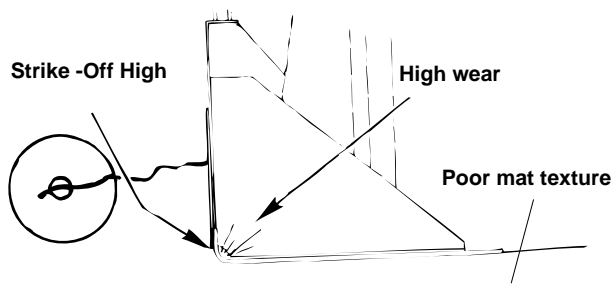

Figure 27

## Strike-Offs and Blades (Affects Angle-of-Attack)

If the fixed strike-offs are set too low for the material design being used, not enough material is allowed to pass under the screed. This lack of material does not provide the necessary lift or float. To maintain a given depth, the angle-of-attack must be increased to compensate for the lack of lift. In this condition the screed is running with an excessive nose-up attitude. Only the rear portion of the screed is actually compacting and finishing the material being placed. Poor mat texture occurs and extreme wear is introduced to the rear or trailing portion of the screed bottom. (Figure 28)

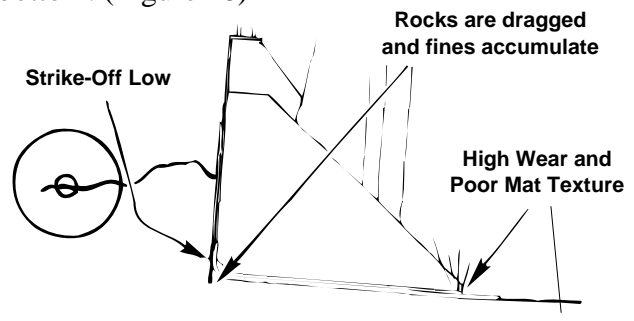

Figure 28

## Hydraulic Strike-offs

The hydraulic strike-offs (that could be or are mounted on Fastach screeds) provide the contractor with a means to extend paving widths in job types that do not require actual screed with heat and vibration. Hydraulic strike-offs can be fitted with standard vertical blades or screeding blades for different applications. If these blades are assembled improperly (or out of adjustment for the material design being placed) they can have an influence on the angle-of-attack much as fixed strike-offs can.

## Vertical and Screeding Blades

When vertical or screeding blades are adjusted correctly they can be extended and retracted without influencing the mat directly behind the main screed. When extended, the thickness of the material placed by the hydraulic strike-off will be thicker than that of the main screed since the material placed by the hydraulic strike-off is only struck off and isn't compacted like that of the main screed. The thickness difference should be adjusted for the material design being used. If adjusted properly, the roller will compact the thicker material placed by the hydraulic

strike-off to the same elevation of the main screed mat when rolled, producing uniform density across the width of the mat. Mat texture, however, will be different from that of the main screed. The hydraulic strike-off provides only limited surface finishing. The texture difference is dependent on the material design being placed. Screeding blades are intended for finer grade materials traditionally used in parking lots and low specification jobs, where vertical blades are intended for the coarser grade materials traditionally used in general road construction.

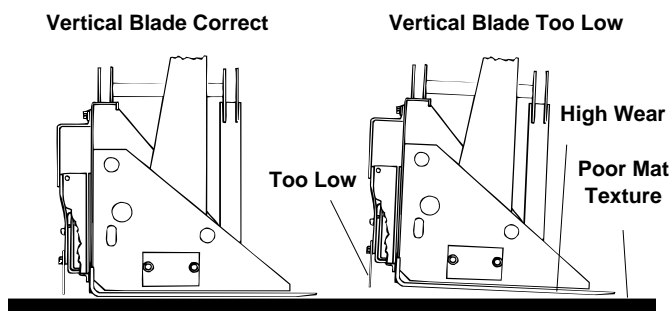

Figure 29

### Vertical Blades

Figure 29 shows correctly and incorrectly adjusted vertical blades. If adjusted low and retracted in, the vertical blades will act as the primary metering device for the main screed and not enough material will be allowed to pass under the screed. This lack of material does not provide the necessary lift or float. To maintain a given depth, the angle-of-attack must be increased to compensate for the lack of lift. In this condition the screed is running with an excessive nose-up attitude with only the rear portion of the screed actually compacting and finishing the material being placed. This causes poor mat texture and extreme wear at the rear or trailing portion of the screed bottom.

Another problem occurs when extending and retracting the hydraulic strike-offs, as this actually changes the amount of material metered to the screed. When retracted in, the hydraulic strike-offs starve the main screed; extended, the fixed strike-offs provide the correct metering. These conditions can produce deviations in the mat.

If adjusted too high, the hydraulic strike-off will not affect the texture or profile of the mat behind the

### Strike-Offs and Blades (Affects Angle-of-Attack)

main screed when extended or retracted. But when extended, the thickness of the material placed by the hydraulic strike-off cannot be compacted down to the same level as the main screed mat.

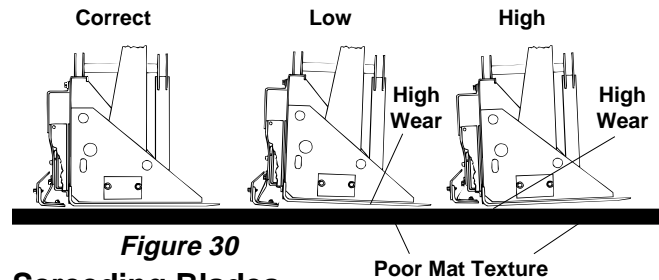

Figure 30

### Screeding Blades

Figure 30 shows the screeding blades correctly adjusted and incorrectly adjusted. If the hydraulic strike-offs are adjusted low and retracted in, the screeding blades will act as the primary metering device for the main screed. In this condition, not enough material is allowed to pass under the screed. This lack of material does not provide the necessary lift or float. To maintain a given depth, the angle-of-attack must be increased to compensate for the lack of lift. In this condition the screed will be running with an excessive nose-up attitude, with only the rear portion of the screed actually compacting and finishing the material being placed. This causes poor mat texture and extreme wear at the rear or trailing portion of the screed bottom.

If the hydraulic strike-offs are adjusted high and retracted in, the screeding blades will create a funnel feed effect for the main screed. In this condition, too much material is allowed to pass under the screed. This increased flow of material provides unnecessary lift or float. To maintain a given depth, the angle-of-attack must be decreased to compensate for the increased lift. This will cause the screed to run with a slight nose-down attitude. Only the front portion of the screed will be actually compacting and finishing the material being placed, causing poor mat texture and extreme wear at the front portion of the screed bottom.

In both conditions mentioned above, extending and retracting the hydraulic strike-offs produces deviations in the mat much the same way as vertical blades affect the flow of material to the main screed when adjusted low.

The line-of-pull refers to the angle at which the screed is being towed forward. Best results occur when the towing force is applied relatively parallel to the grade. To do this we set the tow point cylinders in relation to the general depth we will be paving.

**Rule of Thumb:** Thin mats will require a lower initial tow point setting, while thicker mats will require a higher initial tow point setting.

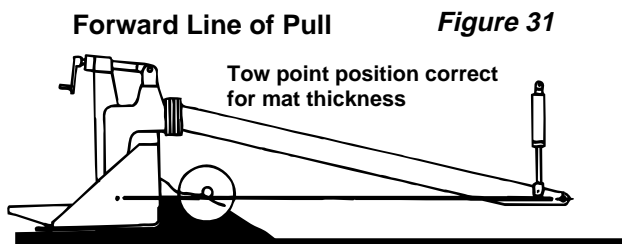

In figure 31, the tow point is set lower because we are placing a thin mat. The line-of-pull on the screed is relatively parallel to the grade. By setting our initial tow point height to match the thickness of material we are placing, the towing forces applied to the screed are relatively parallel to the grade. In this condition we are avoiding unwanted influences being applied to the screed that could cause texture and deviation problems to occur.

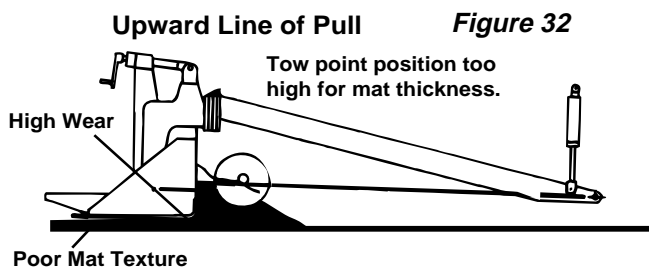

Figure 32 shows the same thin mat being placed, but the initial tow point setting is extremely high. In this condition the towing forces are being applied at an upward angle, increasing the lift forces applied to the screed. To maintain a given depth, the angle-of-attack must be decreased to compensate for the increased lift. The screed is now running with a slight nose-down attitude. Only the front portion of the screed is compacting and finishing the material being placed, causing poor mat texture and extreme

Line of Pull  
(Affects Angle-of-Attack)

wear at the front portion of the screed bottom. Also, when the screed stops, it will have more of a tendency to rock or teeter as the tractor relaxes the tension on the screed. This could increase the amount of settling and deviations introduced to the mat.

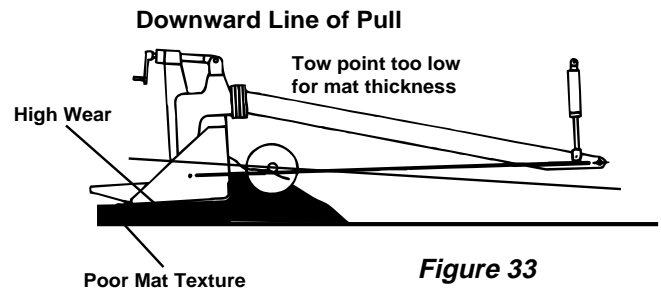
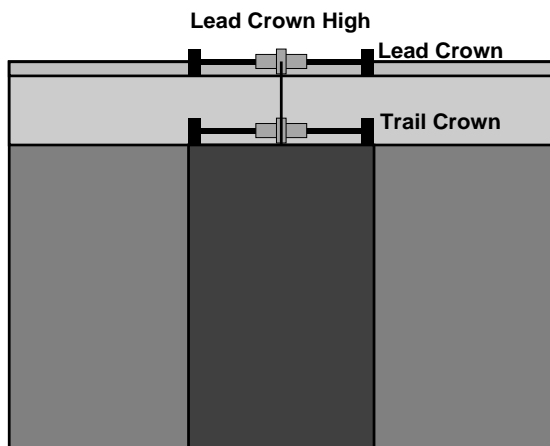

Figure 33 shows a thick mat being placed, but the initial tow point setting is extremely low. In this condition the towing forces are being applied at a downward angle, decreasing the lift forces applied to the screed. To maintain a given depth, the angle-of-attack must be increased to compensate for the decreased lift. The screed is now running with an excessive nose-up attitude. Only the rear portion of the screed is compacting and finishing the material being placed, causing poor mat texture and extreme wear at the rear portion of the screed bottom. Also, when the screed stops, it will have more of a tendency to rock or teeter as the tractor relaxes the tension on the screed. This could increase the amount of settling and deviations introduced to the mat.

We can gain increased control on the forces applied to the screed by setting the tow point in relation to the thickness of the mat being placed. It is not necessary to try measuring the height of the tow point in relation to the screed, to get it set. As the illustrations show, we want to avoid the extremes and keep the tow point relatively parallel to the grade or line-of-pull.

Main Screed Crown

The main screed crown has two adjusters, the lead and trail. When the main screed crown needs to be set for profile specifications, both lead and trail crowns are adjusted simultaneously, by means of a connecting chain. The lead crown can be set independently of the rear, to allow a little extra material to pass into the center area of the main screed. This is necessary to compensate for the void area created by the auger-conveyor drive case. The normal amount of lead crown is  $\frac{1}{16}$  inch to  $\frac{1}{8}$  inch above that of the rear. This range is sufficient for most all materials designs.



**Figure 34**

Figure 34 shows the effect of adding too much lead crown. In this condition the mat texture is open in appearance on both left and right outside areas of the mat, while the center area appears tighter in texture. Extreme wear is introduced to the center area of the screed bottom.

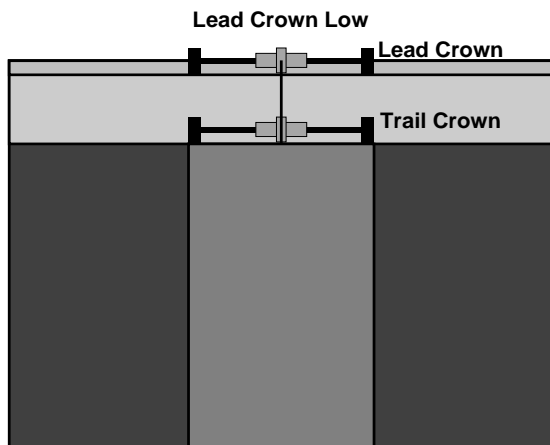

**Figure 35**

Figure 35 shows the effect of having the lead crown set too low. In this condition the mat texture is tighter in texture on both left and right outside areas of the mat, while the center area is open in appearance. Extreme wear is introduced to the center area of the screed bottom.

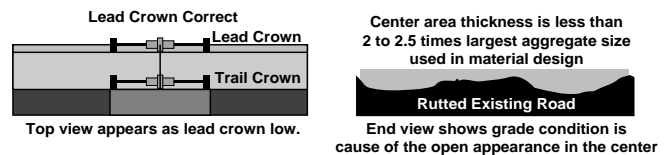

**Figure 36**

A rutted grade condition can cause the mat texture to appear just like that caused by a lead crown adjustment set too low. (Figure 36)

This condition is quite common when overlaying existing roads. Adjusting the lead crown will not correct the texture problems caused by the grade conditions. Trying to do so will result in increased wear being introduced to the center area of the screed bottom, with no improvement to mat texture. To correct these mat texture problems, pre-correction leveling courses should be considered or re-profile the existing road by a grinder or profiling machine.

There are two other factors that can introduce a striping effect somewhat similar to a lead crown adjustment. These are segregation and pre-compaction. Neither of these factors can be corrected by adjusting the lead crown. Refer to these subject headings for more information.

Head of Material

When we refer to head of material, we are referring to the level or amount of material that is directly in front of the screed.

**The importance of fully understanding and controlling the head of material cannot be overemphasized.**

Most mat problems are caused by not maintaining a uniform constant level of material in front of the screed. It is recommended the head of material be half the depth of the auger uniformly across the total width of the screed (just to the level of the shaft).

The head of material exerts a force against two areas of the screed, the mold board or face of the screed and the front areas of the screed bottom. The forces applied resist forward movement of the screed and provide lift.

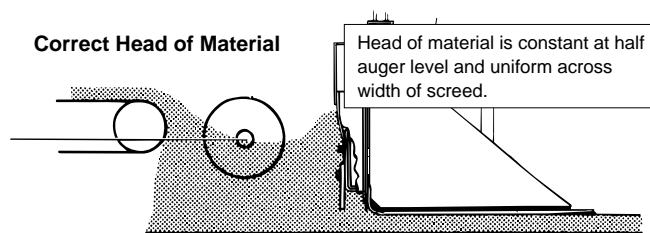

Resistance to forward movement and lift force are constant

**Figure 37**

When the head of material of is maintained at a consistent half-auger level and uniform across the width of the screed, the forces acting against the screed are constant. The angle-of-attack on the screed remains unchanged, the density and texture of the material across the width of the mat is uniform. Also, the augers are more efficient if the material level is at half an auger. (Figure 37)

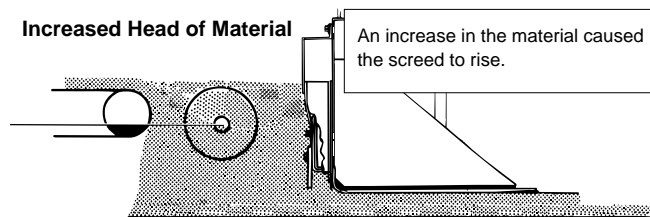

Resistance to forward movement and lift force are increased causing mat to become thicker.

**Figure 38**

As the head of material rises, the resistance to forward movement increases and the amount of lift force increases. This causes the screed to rise to a new level where the forces are balanced or the equilibrium between screed weight, vertical lift forces, resistance to forward movement, and paving speed are reestablished. (Figure 38)

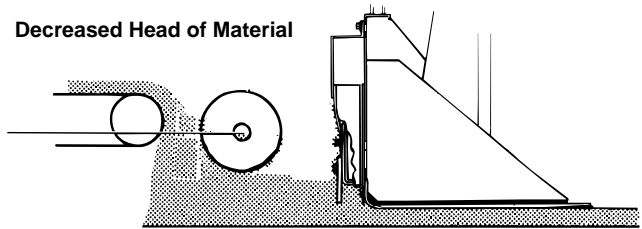

Resistance to forward movement and lift force are decreased resulting in the mat getting thinner

**Figure 39**

As the head of material drops, the resistance to forward movement and the amount of lift force decreases. This causes the screed to drop to a new level where the forces are balanced or the equilibrium between screed weight, vertical lift forces, resistance to forward movement and paving speed are reestablished. The degree or amount of deviations introduced to the mat is in proportion to the level changes of the head of material. (Figure 39)

Varying levels of material in front of the screed affects the vertical position of the screed and causes mat problems. We recommend maintaining the head of material at half an auger. At this level the augers are far more efficient in moving material across the width of the screed, especially if paving at extended widths. The level can vary slightly as long as it is at a **constant level and uniform** across the width of the screed. When the level of material is constant, the forces acting on the screed are constant.

It is a common misconception that using automatic screed controls will compensate for varying the head of material. This simply is not true. Varying levels of material will cause a instant change in depth. Automation does not control the depth instantly; it averages changes over a longer area. Refer to Screed Reaction Time for more information.

## Controlling Head of Material

Two systems (the flow gates, and the material feed sensors) are independently adjusted but work in conjunction with each other to control the head of material. The flow gates control the level of material in the center area of the auger chamber. The feed sensors control the level of material at the outboard ends of the augers. When set properly to match the paving speed and the width and depth of the mat being placed, a constant, uniform head of material can be maintained.

### Flow Gates

The flow gates control the amount of material that is allowed to pass from the hopper to the auger chamber. As shown in the illustration, the material level from the auger-conveyor drive case to the outboard end of the augers is uniform in depth when the flow gates are set properly.

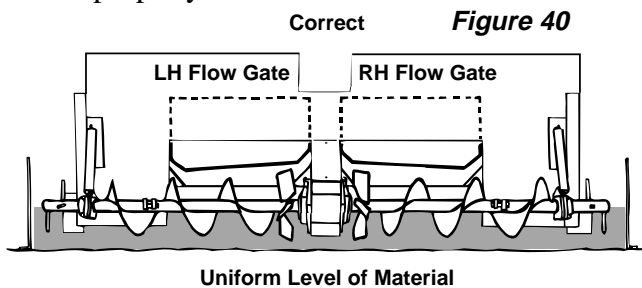

The flow gate setting has a direct bearing on auger rpm. With the flow gates set higher, a larger volume of material is moved from the hopper to the auger chamber. The auger moves this volume of material to the outboard end of the auger. The feed sensor at the outboard end of the auger reacts to the volume of material being carried by the auger, slowing the auger rpm down to maintain a given level. When the flow gates are lowered, the augers have to turn faster to move the same amount of material to maintain the proper level at the feed sensor. (Figure 40)

**Rule of Thumb:** Lower the flow gates for wide-width paving and raise them for narrow-width paving.

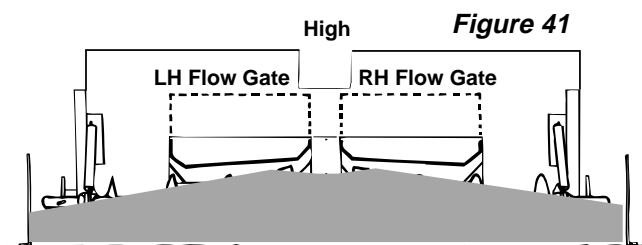

If the left or right flow gate position is set too high, the level of material on that side will be high. The illustration shows both left and right flow gates high. The forces applied to the screed are not uniform across the width of the screed. Forces applied to the center areas of the screed are increased, while the outboard areas are decreased. (Refer to Head of Material.)

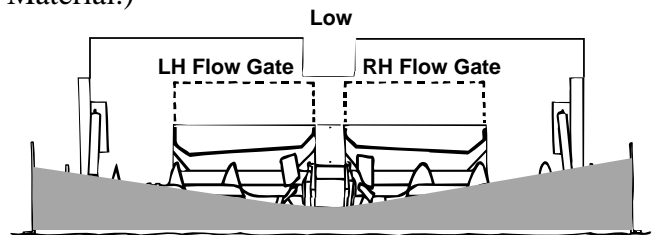

Figure 42

If the left or right flow gate position is set too low, the level of material on that side will be low. The illustration shows both left and right flow gates low. The forces applied to the screed are not uniform across the width of the screed. Forces applied to the center areas of the screed are decreased, while the outboard areas are increased. (Refer to Head of Material.) (Figure 42)

This same condition occurs commonly by running the hopper empty between truck loads. The paver should be stopped before the level of material in the hopper drops below the flow gate setting.

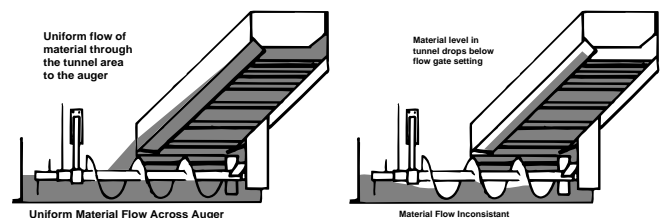

Figure 43

When paving is continued between truck loads, the level of material in the hopper should not be allowed to drop below the flow gate setting. If the level of material drops below the flow gate setting the amount of material being delivered to the auger chamber drops and the head of material drops. (Refer to Head of Material.) (Figure 43)

## Controlling Head of Material

Even small changes in the amount of material being delivered to the auger chamber can have an effect on the consistency of the mat produced. (Figure 44)

**Figure 44**

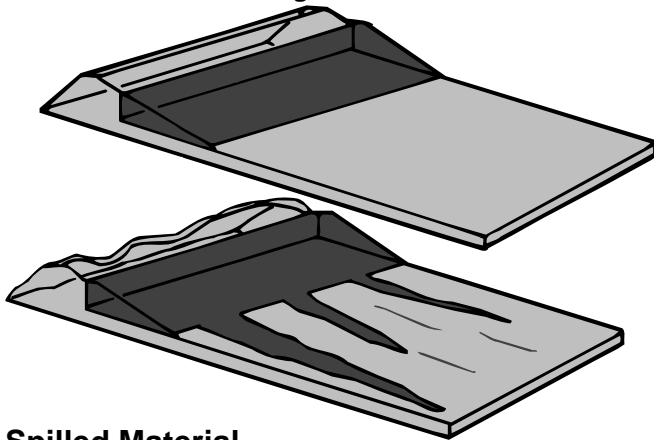

### Spilled Material

Material dropped in front of a paver by trucks or damaged hopper flashing is very common. This is also a prime source of mat-related problems. The material that is deposited in front of a paver adds to the volume of material in the auger chamber as the paver passes over it. This increased volume increases the head of material in front of the screed. (Figure 45)

If the material deposited is raked or shoveled out over a wide area in an attempt to prevent overloading or changing the head of material, a second problem is created. The material that was spread out cools considerably and adds to the elevation of the road surface. When the paver passes over this area the

**Figure 45**

- Material dropped in front of paver causes:
1. Overfeeding of the screed (head of material)
  2. Increases elevation of grade (mat texture problems)
  3. Creates more grade irregularities

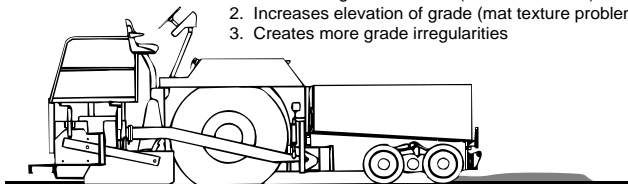

mat thickness in these areas is thinner. This could cause mat texture problems related to paving depth versus aggregate size. This also creates more deviations in the grade that we have to pave over. If material is dropped in front of the paver, it should be removed to prevent adversely affecting the operation.

(Refer to Material Designs for more information.)

### Material Feed Sensors

The feed sensors control the level of material at the outboard end of the augers and work in conjunction with the flow gate settings to maintain a constant, uniform head of material. Cedarapids uses three types of feed sensors: the limit switch type, the proportional sensor and sonic feeder controls. The position of the feed sensor should always be located at the outboard end of the last auger or off the end gate, if variable width paving is done. (Figures 47-49)

#### Limit Switch

The limit switch feeder controls are the on-off type. When the material level rises to a set point, the auger-conveyor system for that side is shut off.

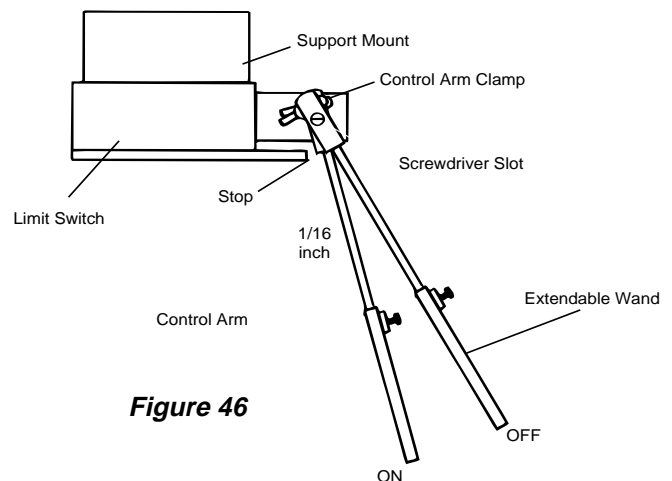

**Figure 46**

When the material level drops below a set point, the auger-conveyor is turned on. (Figure 46)

#### Limit Switch Setup

- (1) Loosen control arm clamp so it is loose on the switch shaft.
- (2) Lower control arm to within  $\frac{1}{16}$  inch of the positive stop that keeps it from swinging farther downward.
- (3) Turn the switch shaft, which has a screwdriver slot, until an audible click indicates the internal contacts have closed. While holding that setting, tighten the control arm clamp.
- (4) Adjust the length of the control arm so the

Controlling Head of Material

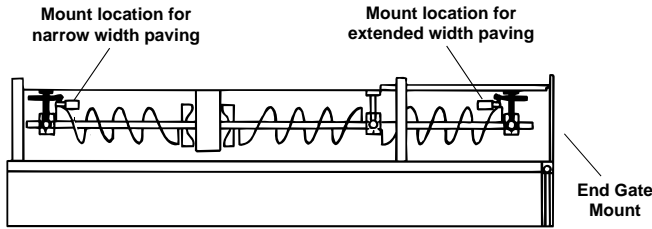
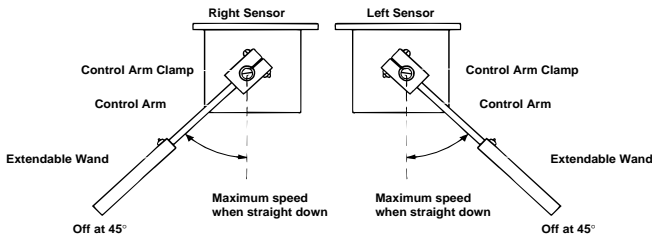

**Figure 47 - Limit Switch Mounting Positions**

auger-conveyor stops when the desired material level is achieved.

**Proportional Feed**

The proportional feed system delivers material at a variable rate depending on the position of the feed sensor control arm. When the control arm is straight down, the system operates at maximum delivery speed. When the material level builds up and the control arm rises, the feed rate slows proportionally. When the control arm reaches a 45 degree angle, the

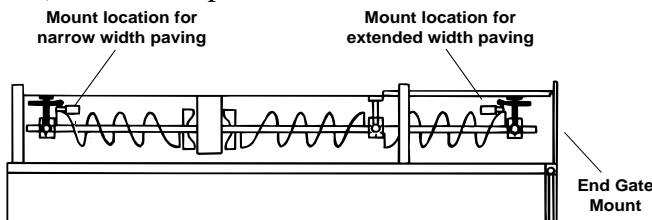

**Figure 48**

feed system shuts off. As material is used and the control arm drops, the feed system starts again. (Figure 48)

**Proportional Feed Setup**

- 1) Remove the feed sensor assembly. Position it on a flat surface or clamp assembly to the tow arm so control arm hangs straight down.
- 2) Set conveyor switch to **auto**.
- 3) Set brake switch to **release**.
- 4) Turn the speed dial to **zero**.



**Figure 49 - Proportional Feed Sensor Mountings**

- 5) Advance the travel control lever **forward**.
- 6) Set auger conveyor switch to **auto**.

**WARNING!**

*All personnel should be prepared for the paver to creep forward.*

- 7) Loosen control arm clamp so the arm is free to rotate on the sensor shaft.
- 8) Position control arm at 45°. See illustration for both left and right sensor control arm positioning.
- 9) While holding control arm in position, rotate sensor shaft with a screwdriver until the auger just stops.
- 10) Tighten the control arm clamp.

**Generation III Sonic Feed Control**

Upgrading from standard proportional systems to Demand Based Ultrasonics does not require changing or rewiring existing tractor systems. Simply mount the control units on each side of the screed and plug their cables into the receptacles the proportional systems used.

**Operation**

The sensor should be mounted in a position that targets the cone-shaped field of view on the **active material** flow path. The longitudinal axis of the **sensor should be perpendicular** to the face of that

The sensor control range is from 12 to 30 inches from the face of material.

If mounted closer than 12 inches, the control detects an out-of-tolerance value and shuts the augers off.

If the distance to the material face is greater than 60 inches (5 feet), the control detects an out-of-tolerance value and shuts the augers off.

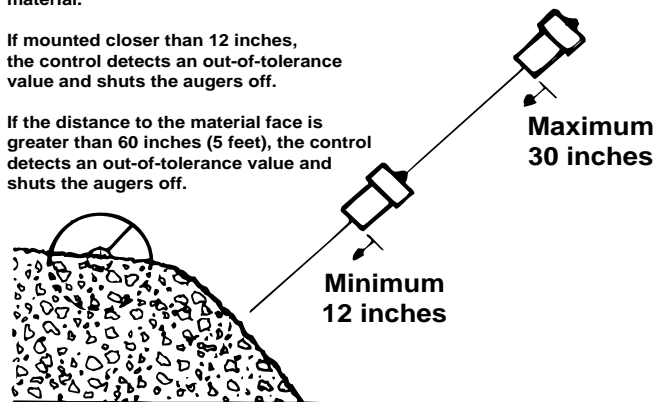

**Figure 50 - Setting Sensor Distance**

Controlling Head of Material

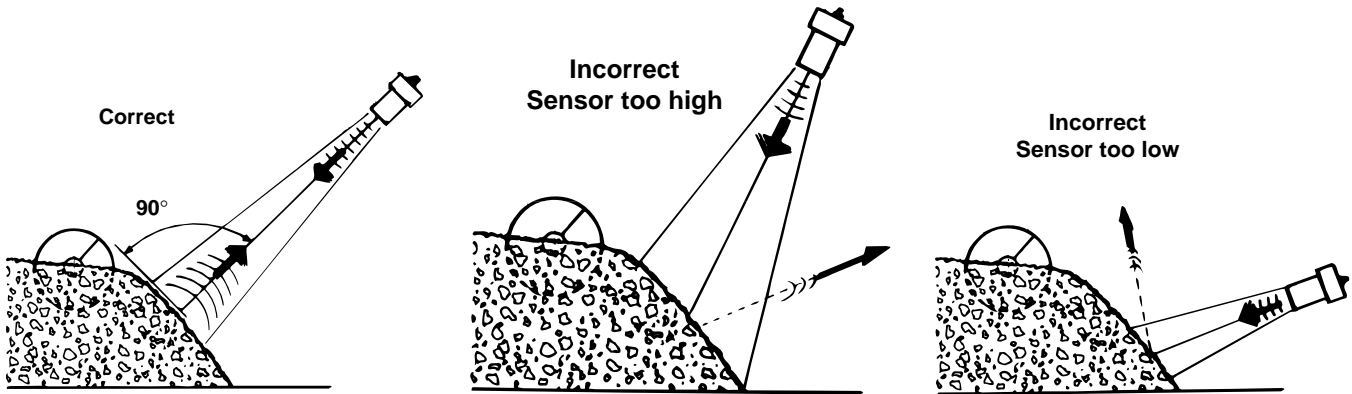

**Figure 51 - Setting Alignment of Sensor with Head of Material**

material. Figure 50 will help in selecting mounting location and targeting the sensor to help prevent some common problems that could be encountered. For best possible results, the sensor should be targeted perpendicular (90°) to the material surface being monitored. (Figure 51) Misalignment decreases the amount of return echo to the sensor. The type of material being used determines the amount of misalignment tolerance. Fine graded material designs like sand mixes have a low reflective value and

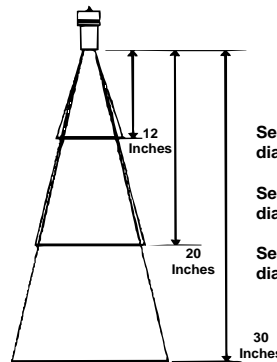

**Figure 53**

Sensor nulled at 12 inches from face has 6 inch diameter view window  
 Sensor nulled at 20 inches from face has 7.5 inch diameter view window  
 Sensor nulled at 30 inches from face has 9.5 inch diameter view window

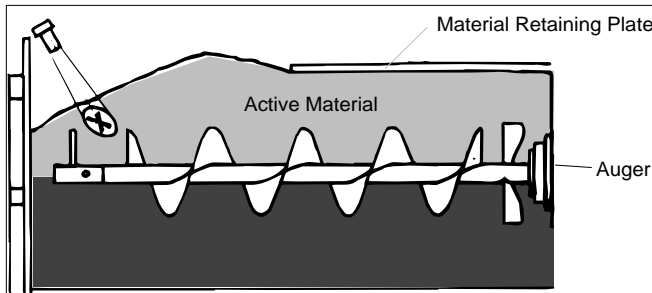

**Figure 52**

Target in the Center Area

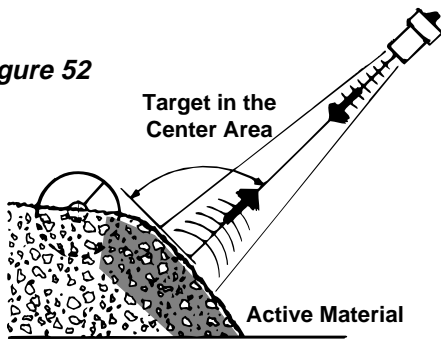

require the sensor to be targeted perpendicular while coarse graded material designs have a high reflective value and may allow up to a 10° misalignment.

The sensor should always be targeted on the material that is actively moving. This area is usually on the

forward outboard end of the auger as illustrated. The sensor should be targeted in the center area of the face of material for best results. (Figure 52)

As we can see in figure 53, the size of the view

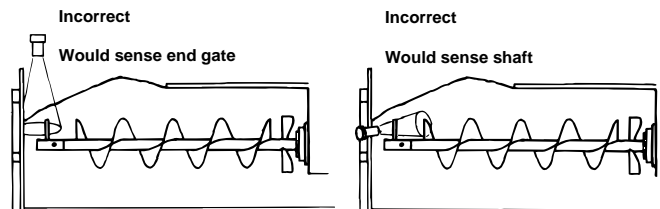
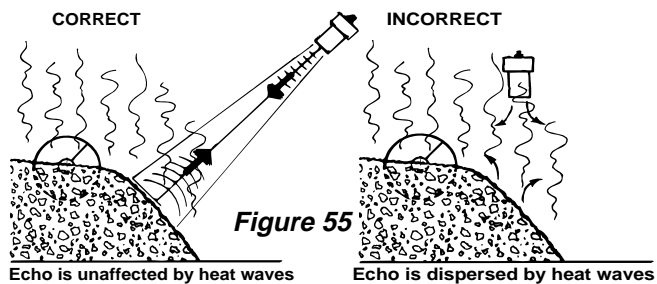

**Figure 54 - Incorrect Sensor Mounting Positions**

window increases in diameter as the sensor's distance from the surface increases. The sensor will react to the closest object inside its view window.

The most common problem encountered with the use of sonic feeder controls is improper mounting and targeting. As in figure 54, the system will react to the object inside the view window that is closest to the sensor. Care must be taken in mounting and

Controlling Head of Material



**Figure 55**

targeting the sensors to prevent sensing objects other than the desired material level. (end gates, augers, material retaining plates, etc.)

**Effect of Heat Waves**

The sensor should be mounted far enough away from the material that the sensor is not inside the rising heat waves. Large temperature fluctuations can cause dispersion or loss of the echo due to refraction of the sound waves. (Figure 55)

The performance of the system could also become erratic if the temperature of the transducer (transmitter/receiver) rises above 128°F. The transducer will quit operating at approximately 150°F.

**End Gate Mounting**

It is best to mount the sensor on the end gate when the strike-off is extended or retracted. This provides better control of the material and keeps the sensor out of the rising heat waves that could affect the performance of the sensor. Care must be taken in routing the sensor cable to prevent damaging the cable when extending or retracting the strike-off or hydraulic extension. (Figures 56 & 57)

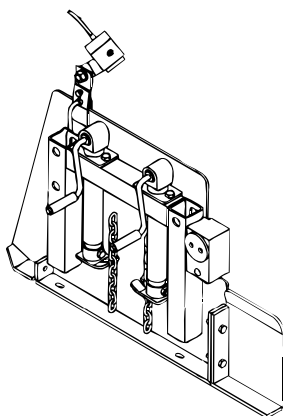

**Figure 56 - End Gate Mounting on Fastach 8 ft. and 10 ft. Screeds**

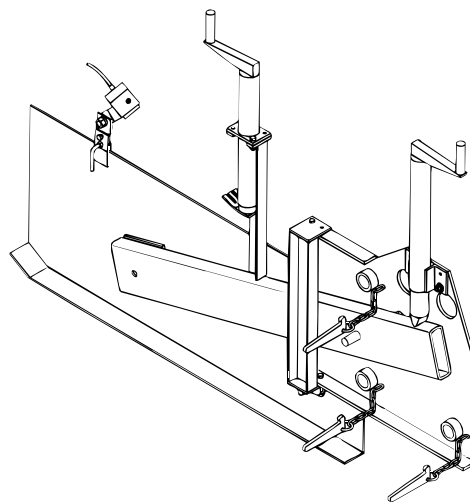

**Figure 57  
End Gate Mounting on the Stretch 20 Screeds**

**Setup**

To null or select the desired level or material, use the manual feed system to fill the auger chamber to the desired level or the auger shaft.

When the correct level has been reached, place the auger/conveyor switches in the AUTO position and start moving the paver forward. As the paver starts moving, press and release the NULL switch to null the system.

**Note:** This control will only operate when the paver is moving forward.

If the material level needs to be changed after nulling, use the UP/DOWN toggle switch. By pressing down and releasing the switch, the material level will decrease approximately 1/2 inch (1.17 cm). By pressing up and releasing, the material level will increase approximately 1/2 inch (1.17 cm).

The sonic system will remember the null setting when shut off. This will eliminate the need to reset the null for each day's paving. Re-nulling or using the UP/DOWN controls is needed only if a new material level is desired.

Material Design

This section will cover the practical application of mix designs as they relate to the paving operation and common problems incurred. For further information, there are numerous publications and studies that can be acquired from institutes that deal with the mechanics and engineering aspects of mix designs.

It is important to understand that each mix design is different in relation to its flow characteristics and how it affects the configuration of the paver and screed. A dense or course grade mix will require a smaller angle-of-attack on the screed to produce a given depth than would a fine or tender grade mix.

When dealing with mix designs, **consistency** of the design is extremely important in the paving operation. This means the gradation (blend of aggregates, fines, and fillers), asphalt content, moisture content and temperature have to remain constant. If any of these vary, it will have an effect on the mat profile (deviations), texture or density of the mat being placed.

Several factors of mix design have a great effect on the texture and compaction of the mat. They are: gradation, aggregate size, asphalt content, and temperature.

**Gradation of Material Design**

The gradation of a mix design determines the angle-of-attack required on the screed to produce a given depth, texture, and compaction characteristic. If the gradation remains constant between truck loads, the screed can be adjusted to produce a uniform mat and the rolling operation can establish patterns that

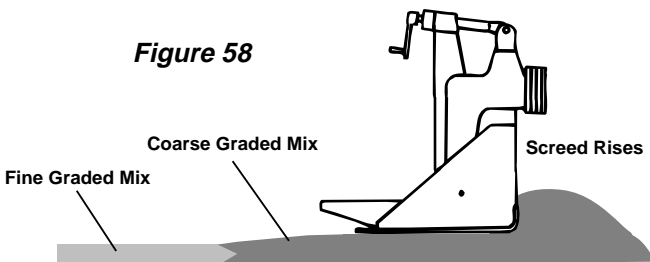

Figure 58

compact the material to specification. If the gradation of the material varies, it affects the angle-of-attack on the screed, producing deviations in depth and mat texture. Also, there can be problems in establishing a roll pattern. (Figure 58)

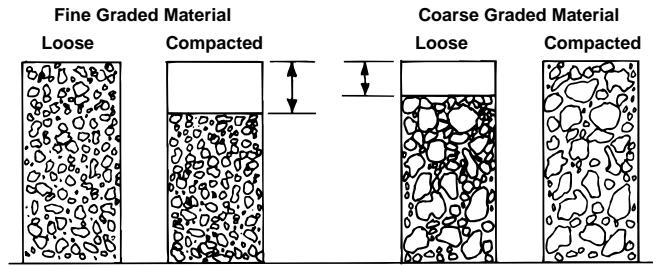
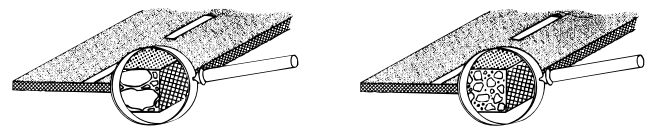

Figure 59

Figure 59 shows coarse-graded materials compact less than the finer graded materials. If, for example, a paver was set up to place a finer grade material (which will require a larger angle-of-attack to produce a given depth) and then the gradation of the material became coarser, the screed would have a tendency to rise. This is due to the compaction rate differences of the gradation. Varying the gradation of a mix changes the density of the material and in turn changes the factors affecting the equilibrium of the screed.

**Aggregate Size In Relation To Paving Depth**

It is recommended the minimal paving depth be 2 to 2½ times the largest aggregate size, for best possible mat texture. This allows vibration and weight of the screed to rearrange aggregates and fines into a tight uniform mat. Paving thickness should **never** be below 1½ times the largest aggregate size. If below this, the screed will be supported by the larger aggregates and will no longer float on the material. This causes the screed to mirror the grade deviations below it and mat texture will be extremely poor. (Figure 60)



Mat thickness is below 1½ times largest aggregate size. Screed is actually supported by the large aggregates.

Mat thickness of 2 to 2½ times largest aggregate size produces tight, uniform mat.

Figure 60

The screed is not capable of placing materials thinner than the largest aggregate size used in the material design. It is quite common to have job specifications that require a shoulder area to be tapered from full mat thickness to nothing on the outside. If a screed

## Material Design

or hydraulic strike-off is configured in an attempt to do this, the grade deviations will be mirrored or duplicated in the mat being placed. (Figure 61)

When screed is supported by aggregates, deviations are transmitted across the width of the mat.

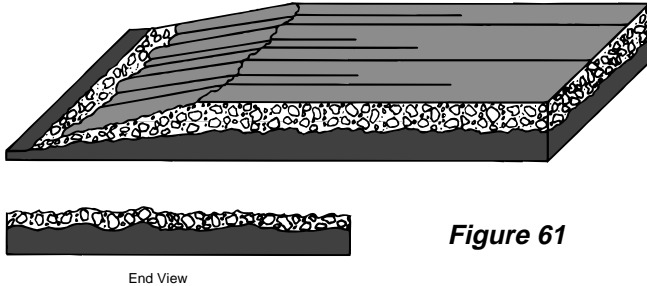

**Figure 61**

When job specifications require a shoulder be tapered to nothing on the outside, the outside depth should not be less than  $1\frac{1}{2}$  times the largest aggregate size over the highest points of the grade deviations. Then a rake or lute should be used to feather the taper on out to zero depth. Using this method assures the screed of having enough material under it to float and will not mirror any of the grade deviations into the mat being placed. (Figure 62)

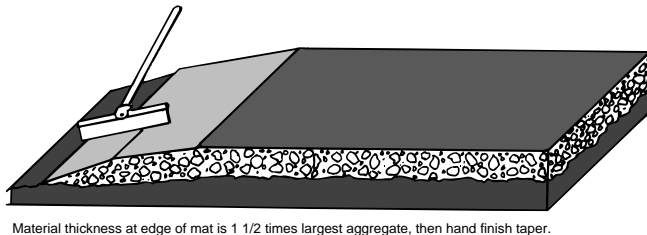

Material thickness at edge of mat is  $1\frac{1}{2}$  times largest aggregate, then hand finish taper.

**Figure 62**

Grade conditions or deviations in the existing grade can have an effect on the texture and profile of a fairly thin mat being placed over it. This is a common condition encountered in overlay jobs where  $1\frac{1}{2}$  inches to 2 inches of  $\frac{3}{4}$  inch minus ( $\frac{3}{4}$  inch largest aggregate) material is placed over an existing grade. Material thickness over the high points in the grade can be below the 2 to  $2\frac{1}{2}$  times recommended depth in relation to aggregate size. These areas will show an open, rough texture compared to the surrounding mat. This traditionally will require a lot of hand work (back casting of material) in an attempt to correct the appearance of the mat. This type of condition not only causes mat texture problems, but affects the rolling operation when trying to achieve compaction. The roller drum is supported by these high points and density decreases. (Figure 63)

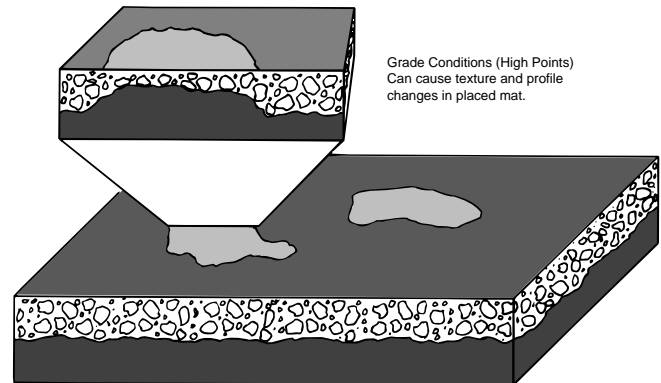

**Figure 63**

On jobs where depth cannot be increased due to yield specifications, consider pre-correcting the grade conditions. Removing the high points in the existing grade produces a more uniform mat.

### Asphalt Content

The asphalt content of a mix design determines the angle-of-attack required on the screed to produce a given depth, texture, and compaction characteristic. If the asphalt content remains constant between truckloads and all other factors remain unchanged, the screed can be adjusted to produce a uniform mat and the rolling operation can establish patterns that compact the material to specification.

If the asphalt content in the material varies, it affects the angle-of-attack on the screed, producing deviations in depth and mat texture. Problems such as shoving or material displacement can also occur. The asphalt content, like the gradation, also affects the compaction rate of material. Variations in asphalt content can make it impossible to establish a roll pattern that achieves satisfactory compaction.

Material Design

Mixes with high asphalt content are more fluid in reaction than the lower content mixes. If a paver is set up to place a high asphalt content mix, and during operation the asphalt content of the mix decreases, the screed will have a tendency to rise. (Figure 64) This is due to the differences in flow characteristics of the asphalt content. Varying asphalt content of a mix changes the density of material and in turn changes the factors affecting the equilibrium of the screed. (Refer to Angle-of-Attack.)

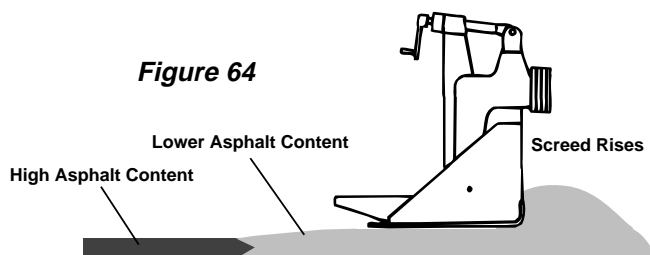

**Temperature of Material**

The temperature of a given material is an important factor related to material design. Asphalt cement is a solid at room temperature. It becomes fluid after being heated and becomes a solid again after cooling. Problems of mat texture and deviations occur when materials cool to the point of becoming a solid. (Figure 65) **Asphalt Cement**

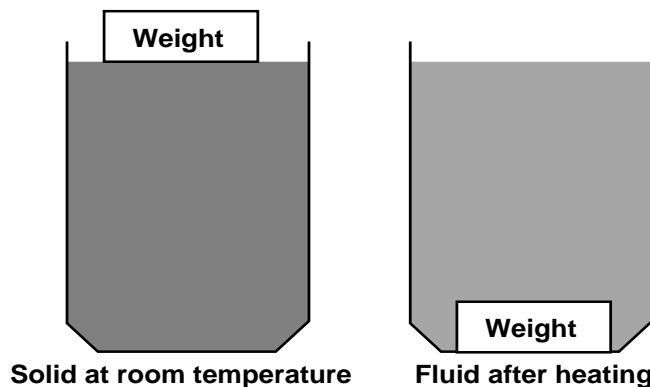

Figure 65

The most common of these deviations are created after stopping the paver. The volume of material, in front of and under the screed, starts cooling the instant the paver stops. As the material cools it loses its fluid characteristics and acts more like a solid. This changes the factors that affect the equilibrium or balance of the screed. The screed will rise when

paving is resumed to reestablish the balance. As hot material replaces the colder materials, the screed will drop down to its original position. This problem occurs all during the paving season but becomes more evident in the fall and early spring when ground temperatures are lower. (Figure 66)

The same problem can occur while the paver is moving if a cold truckload of material is delivered. The temperature of material in each truckload cannot vary more than 10°F to 20°F before it starts showing effects in texture and deviations in the mat.

The paving speed should be set to match the rate at which material can be delivered to the paver and the number of stops be held to an absolute minimum. (Refer to Stopping and Starting Paver.)

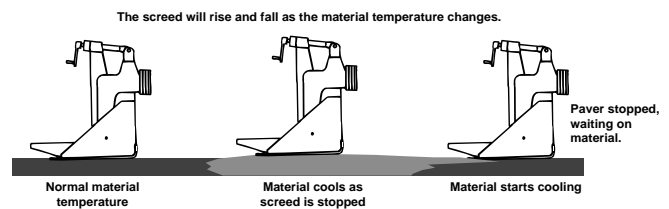

Figure 66

Rolling (Compaction)

Recommended Minimum Laydown Temperature						
Base Temperature	1/2 inch	3/4 inch	1 inch	1 1/2 inches	2 inches	3 inches and above
20 <sub>i</sub> to 30 <sub>i</sub> F (to -1 <sub>i</sub> C)	-----	-----	-----	-----	-----	285
32 <sub>i</sub> to 40 <sub>i</sub> F (0 <sub>i</sub> to 4 <sub>i</sub> C)	-----	-----	-----	305	295	280
40 <sub>i</sub> to 50 <sub>i</sub> F (4 <sub>i</sub> to 10 <sub>i</sub> C)	-----	-----	310	300	285	275
50 <sub>i</sub> to 60 <sub>i</sub> F (10 <sub>i</sub> to 16 <sub>i</sub> C)	-----	310	300	295	280	270
60 <sub>i</sub> to 70 <sub>i</sub> F (16 <sub>i</sub> to 21 <sub>i</sub> C)	310	300	290	285	275	265
70 <sub>i</sub> to 80 <sub>i</sub> F (21 <sub>i</sub> to 27 <sub>i</sub> C)	300	290	285	280	270	265
80 <sub>i</sub> to 90 <sub>i</sub> F (27 <sub>i</sub> to 32 <sub>i</sub> C)	290	280	275	270	265	260
Over 90 <sub>i</sub> F (Over 32 <sub>i</sub> C)	280	275	270	265	260	255
<b>Rolling Time in Minutes</b>	<b>4</b>	<b>6</b>	<b>8</b>	<b>12</b>	<b>15</b>	<b>15</b>

**Figure 67 - This chart should be used only as a general reference**

The reason for compacting asphalt materials is to make them impervious to water, air and other substances that would cause premature failure of the bond created between the asphalt cement and the aggregates. The rolling or compacting process has no bearing on the paving operation but is essential in meeting specifications for density and smoothness (rideability).

Often, more emphasis is placed on achieving density than on controlling the roller-induced displacement of materials and marks left in a mat during the compaction operation. Controlling roller-induced marking of a mat is as important as achieving density to pass specifications for smoothness, profile, and density. There are numerous publications, books and studies relating to roller compaction that can be acquired from each respective roller manufacturer.

**Temperature Effects on Rolling**

The temperature of mix is an important factor in achieving specification density by the rollers. The roller has a given amount of time where the materials have cooled enough to prevent excessive shoving,

but are still hot enough to achieve compaction. This amount of time varies due to material design, temperature of material, ambient temperature, ground temperature, depth of material and wind velocity.

The normal hot plant output temperatures range from approximately 270°-310°F (132°-155°C) for most material designs. Temperatures above 325°F (163°C) will usually damage the asphalt cement. The normal window of temperature where compaction is achieved is approximately 285°- 180°F (141°-82°C). Some material designs may allow the roller on the material at higher temperatures without excessive shoving or displacement of materials, but these are more the exception than the rule. After the materials have cooled below approximately 180°F (82°C) no further compaction can be achieved. Finish rolling occurs from approximately 190°F (88°C) and below. Its purpose is to remove all the deviations introduced in the mat by the compaction rolling process.

Figure 68 recommends time available for rolling at various mat thicknesses and temperatures.

## Rolling (Compaction)

The actual job site conditions of ground temperature, ambient temperature, wind velocity, material design, material temperature, thickness of mat, width of mat and paving speed will determine the actual amount of time available for rolling (during which density can be achieved).

Figure 68 offers a guide to rolling temperatures. On a hot mat, excessive shoveling or displacement of materials occurs. This introduces (bumps and depressions) in the mat profile that may not meet job specifications for smoothness. If rolling takes place after the materials have cooled too much, compaction **cannot** be achieved.

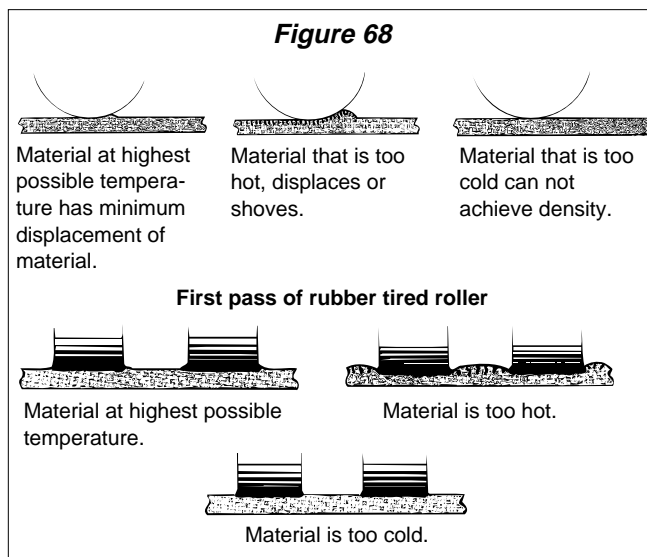

### Paving Depth In Relation To Rolling

The depth or thickness of material being placed has an effect on the smoothness of the compacted mat. There are two factors that have to be taken into account if a compacted mat is to meet specifications for smoothness:

- 1) **Material design** has a given range of depths that it can be placed and compacted to meet specifications for texture and smoothness. If a  $\frac{3}{4}$  inch minus ( $\frac{3}{4}$  inch is largest aggregate size) material is placed at 1 inch in depth, mat texture problems and profile deviations occur, as well as compaction being hard to achieve, due to the tearing and open texture of the mat. If this same material was placed at extreme depths (5 inches to 6 inches) it would become unstable. When rolled, the material would

have a tendency to shove or displace instead of compacting vertically.

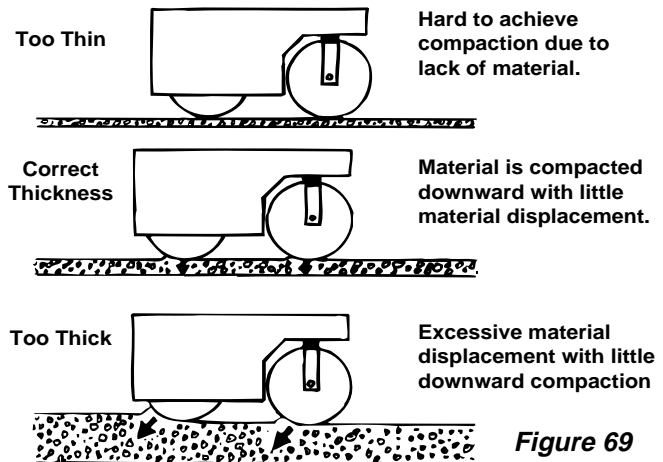

- 2) **Grade conditions** and specifications for thickness of mat directly affect the thickness of material at any given point in mat being placed.

If the existing grade is fairly uniform across the width and length of the job, and a  $\frac{3}{4}$  inch minus material is placed at 2 inches in depth, the mat will be fairly uniform in depth and easily compacted without shoving or displacement of materials, producing a uniformly smooth mat. (Figure 69) If the grade conditions are irregular, with deep depressions and high points across the width and length of the road, the thickness of material will vary throughout the road. Excessive shoving or displacement of materials occurs where depressions are paved over, while high points in the grade tend to support the roller drum, not allowing uniform density to be achieved.

These problems can be effectively avoided by evaluating the grade conditions and pre-correcting the areas where extreme depressions or high points exist. (Refer to Pre-leveling Grade.) (Figure 70)

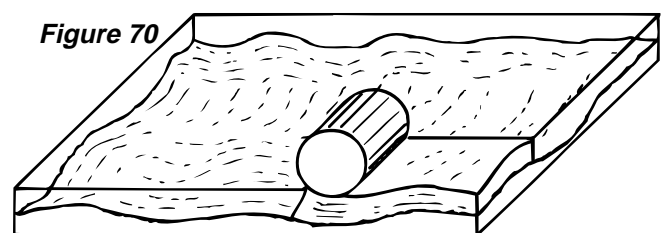

The paver can place a flat uniform mat over an irregular grade, but after rolling, the mat shows smaller mirror images of the grade deflections.

Rolling (Compaction)

Pre-Leveling Grade

Pre-leveling is desired where job specifications require a minimal amount of asphalt materials to be placed over irregular grades to achieve the best possible riding surface. These jobs are bid with a fixed amount of material and require the finished mat to meet specifications of profile, slope and smoothness.

This requires inspecting all areas of the grade for deep depressions, high points and widely varying slopes. Decide how to best repair them before general paving begins. Most inspection agencies will allow a given amount of the total tonnage forecasted for a job to be used in pre-leveling specific areas in the grade if the contractor can explain the advantages of improved profile and smoothness.

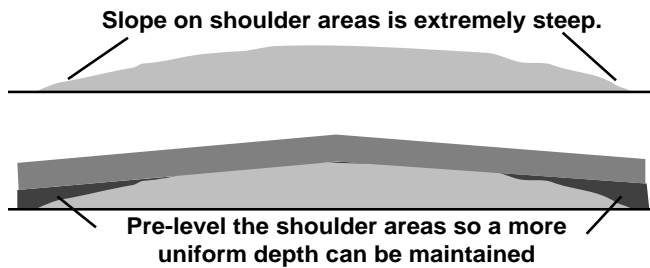

Figure 71

Figure 71 shows that by pre-leveling the shoulder areas, a fairly uniform thickness of material can be placed over the entire grade. When rolled, there will be very little shoving or displacement of materials. The slope of the finished mat will meet job specifications.

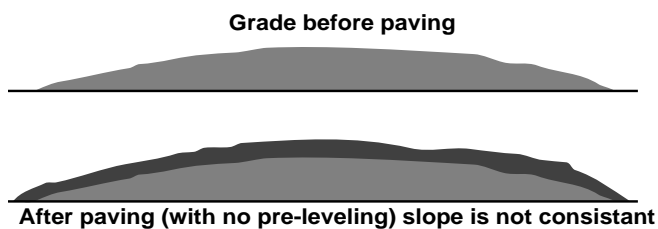

Figure 72

Figure 72 shows that where shoulder areas were not pre-leveled, specifications for slope could not be achieved due to roller displacement of materials and compaction rates.

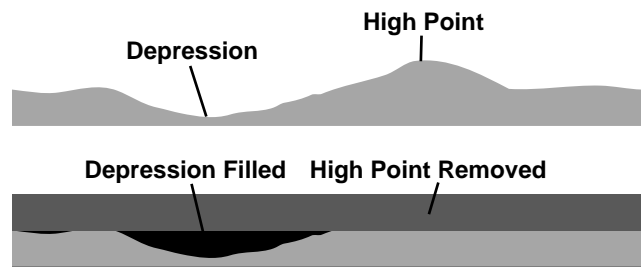

Figure 73

Figure 73 shows a section of grade that has a deep depression and a high point. Pre-leveling of these was done by filling and compacting the depression and cutting the high point off. Then fairly uniform thickness of material was placed over the entire grade. When rolled, there was very little shoving or displacement of materials. The finished mat meets specifications for smoothness.

By not pre-leveling the grade, the deviations reappear in the mat that was placed over them. (Figure 74)

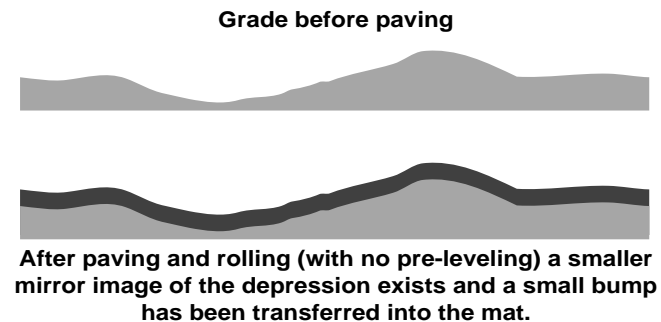

Figure 74

Stopping Roller

The roller should **never** be stopped on a hot mat. If the paver must be stopped (when filling water tanks, for example) move the roller to an area of the mat that has cooled before stopping it. If a roller is stopped on a hot mat it settles into the mat, causing a depression that affects the smoothness of the mat.

Roller Patterns

It is important to realize and understand that roller patterns used for a specific material not only affect density but also affect smoothness or rideability of the job. From a standpoint of smoothness, the roller patterns employed should achieve density while preventing displacement of materials and marking of the mat.

## Rolling (Compaction)

By closely watching roll patterns to prevent displacement of materials and marking of the mat, density and a uniform quality mat can be achieved. There are numerous publications and studies that can be acquired from each roller manufacturer.

### Vibratory Roller Travel Speed

The speed at which a vibratory roller travels while compacting a mat, the travel speed VPM (vibrations-per-minute), and the amplitude (amount of force imparted from the drum to the mat) affect the density and smoothness of the mat. If these factors are not matched to the specific conditions of the mat being compacted, ripples can be introduced in the mat surface. This decreases the rideability or smoothness of the job and it may fail to pass specifications. Specific job conditions have to be evaluated to establish roller speed, VPM and amplitude settings that achieve density without affecting the rideability or smoothness of the job. There are numerous publications and studies that can be acquired from each roller manufacturer.

### Checking Unrolled Mat

There is a very simple method of checking the loose or unrolled mat that will determine whether the source of a smoothness problem is the paving operation or the rolling operation.

- 1) Two boards of equal thickness (2x4 cut in half)
- 2) 30 feet of *strong* string line
- 3) Tape measure or ruler

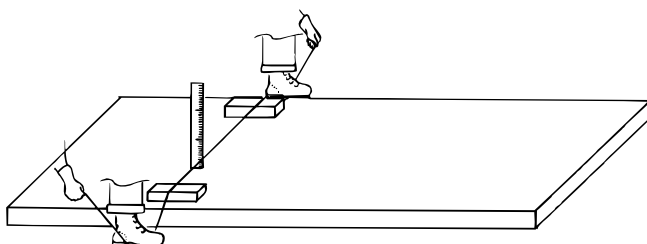

Checking the profile across the width of an unrolled mat.

**Figure 75**

First check across the width of the mat. (Figure 75) Place one board on each side of the mat a few inches in from the edge. Have two people stretch a string line over the boards and across the width of the mat, using their feet to pull the string tight. Take measurements from the string line to the mat, starting close to one side of the mat and checking 2 inches apart across the width of the mat. These measurements will show if any deviations exist across the width of the mat. If deviations exist, adjustment of the screed will be necessary.

The second checks will be made in three places along the length of the mat. (Figure 76) The prime area for deviations to occur is where the screed was stopped. Be sure to check in areas like this. Place the boards approximately 20 feet to 25 feet apart as the illustration shows. Have two people stretch a string line over the boards and under their feet, using their legs to pull the string tight. Measurements from the string line to the mat should be taken, starting close to one board and checking 2 inches apart across the length of the string line. Re-check in all three positions as illustrated. These measurements will show if any deviations exist across the length of the mat. If the checks show deviations in excess of specifications, adjustment of the screed or paver may be necessary. If the checks show the unrolled mat is within specification, there are only two other possible sources; roller-induced deviations or existing grade deviations.

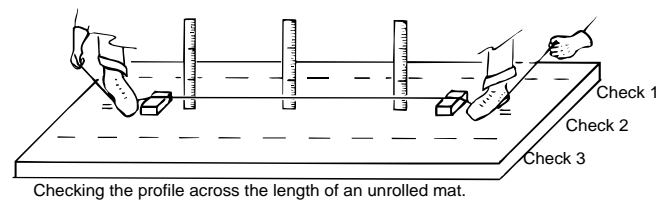

**Figure 76**

---

## Automatic Screed Control

Automatic screed controls provide a means to enhance a paving operation by monitoring and controlling the screed position in relation to the tractor and the reference plane. This eliminates the need for a screed operator to manually introduce the changes that would be necessary for a uniformly smooth mat to be placed over irregular grades.

Automatic screed controls can enhance a proper paving operation by maintaining an established line of grade and/or percentage of slope. However, proper operation means controlling **all** of the factors that can adversely affect the screed. If these factors are not controlled by recommended operational techniques they can introduce a change in the screed's position quickly enough that automation cannot correct them. The automation cannot make up for improper operational techniques. (Refer to Screed Reaction Time.)

Before we try to deal with the various components of the automatic screed controls we need to understand the concepts of *building profile* and *rideability*, as they relate to controlling the screed.

### Building Profile

The screed inherently resists immediate changes in depth or slope and averages changes over approximately five lengths of the tow arm. (Refer to Screed Reaction Time.) Job specifications that require an exact thickness of material and/or slope at any given point in the grade, require the screed to react very quickly to maintain its position in relation to the established line of grade and/or percentage of slope. When building profile we over-correct the screed to force it into changing depth very quickly to maintain exact thickness and/or slope at given points in the grade. Building for profile is not necessarily building a smooth, rideable surface, as changes will be introduced very quickly.

Building for profile is desirable on jobs where two or more layers of pavement will be placed or where exacting slopes (transitions and super elevations) have to be built or maintained. By reestablishing or building the desired profile of a road on the first layer, all other layers can be built for rideability or smoothness.

### Rideability

When building for rideability, automation enhances the screed's resistance to immediate changes, producing a very smooth riding surface. Building for rideability is desirable where job specifications place a high emphasis on the smoothness of the finished job. If two or more layers of pavement will be placed, the first layer should be built for profile to get the grade and slope to proper elevation specifications. All other lifts should be built for rideability, to smooth out any deviations from the previous lift.

### Evaluation of Jobs

Evaluation of specifications and grade conditions on a job is extremely important if the paver and automation are to be configured properly to produce the required results. Failure to properly configure the screed and automation for each phase of the paving operation will result in producing a road that is unsatisfactory or not meet specifications. Just as one size of shoe does not fit everyone, one configuration of the screed and automation will not produce superior results in all conditions and jobs.

### Basics of Automation

The automation system consists of two basic sensory devices, the grade control and the slope control. Both systems operate independently of each other to control the screed's angle-of-attack by moving the tow points up or down in relation to the reference plane of each.

The slope system uses an angular reference plane in relation to the horizon, which is perpendicular to the line of paving.

The reference plane for a grade sensory system can be one of three types, ski (mobile grade reference), joint matcher, or fixed (established) string line. All of these reference in a plane parallel to the line of paving.

### Grade Control

The grade controller consists of a housing containing a grade sensing module and an amplifying module which has indicator lights and a mode operation switch. A counter-balanced sensor arm can be

Automatic Screed Control

attached to either side of the grade sensor. Depending on the application, a wand or a skate assembly is attached to the follower. (Figure 77) A grade sensor can control either the left or right tow point cylinder, depending on which side of the paver it is mounted. Dual grade sensors can also be used to control both left and right sides of the screed.

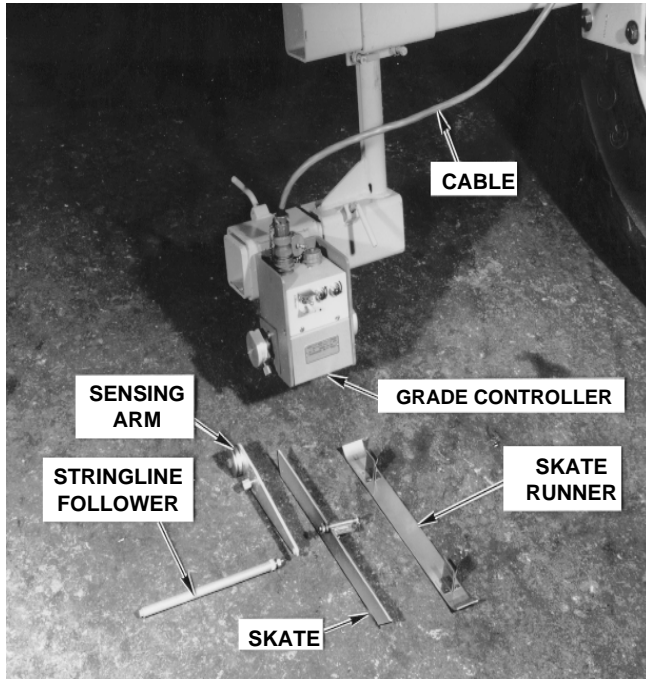
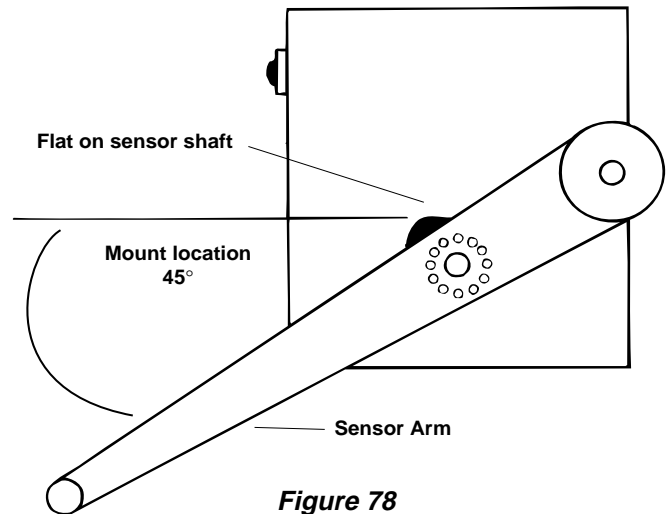

**Figure 77**

The sensor arm can be mounted on either side of the sensor, depending on which side of the paver the sensor is to be mounted. The sensor arm has to be mounted so that it is trailing the sensor at 45° angle in relation to the flat on the sensor shaft, to work properly. (Figure 78)

If the sensing arm is mounted in a position other than 45°, the amount of rotation on the sensor module, in relation to the amount of deflection of the sensing arm, will not produce the correct amount of tow point cylinder movement. (Figure 79)

Mounting the sensor arm at any angle other than at 45°, changes the amount the sensor shaft is rotated for a given deviation. (Figure 80)



**Figure 78**

With the sensor arm mounted at 45°, a 1/4 inch deviation will rotate the sensor shaft 3° 22' 52".

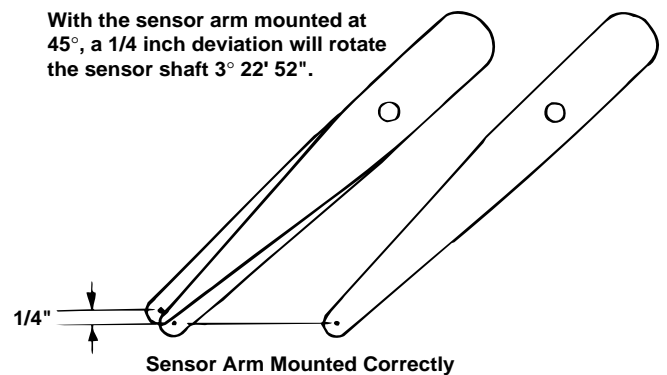

**Figure 79**

With the sensor arm mounted horizontally, the same 1/4 inch deviation only rotates the sensor shaft 2°27'46".



**Figure 80**

Automatic Screed Control

**Grade Sensor Dead-Band**

The deadband of the grade sensor is the amount the sensing arm can move without triggering a tow point cylinder response. A given amount is necessary to allow for normal machine vibration.

Set the deadband by removing the screw located on the face of the grade sensor. An adjustment potentiometer is located under the face screw. (Figure 81) Using the small screwdriver provided, clockwise rotation will increase the amount of deadband, while counterclockwise will decrease the amount of deadband. Use the nickel/dime (.080/.050 inch) method in setting the deadband. When the sensor is nulled (positioned so both lights are out), a dime can be passed under the follower without triggering a light, but a nickel passed under the follower will trigger a light response.



**Grade Sensor**  
**Figure 81**

Automatic Screed Control

**Slope Control**

The slope control system consists of a hand-held remote set unit, a slope sensor (pendulum) and an amplifier module which has indicator lights and a mode operation switch. On the CR351 and CR361 pavers the slope sensor and amplifier modules are incorporated into the same mount housing. (Figure 82) All other models have the slope sensor and amplifier modules mounted separately. (Figures 83 & 84)

The slope control system can control the left or the right tow point cylinder and is capable of maintaining up to 10% positive or negative slope from each side of the paver. (Figure 85)



Slope Sensor, 400 and 500 Series Pavers  
**Figure 83**



Slope System Components of the 300 Series Pavers  
**Figure 82**



Slope Controller, 400 and 500 Series Pavers  
**Figure 84**

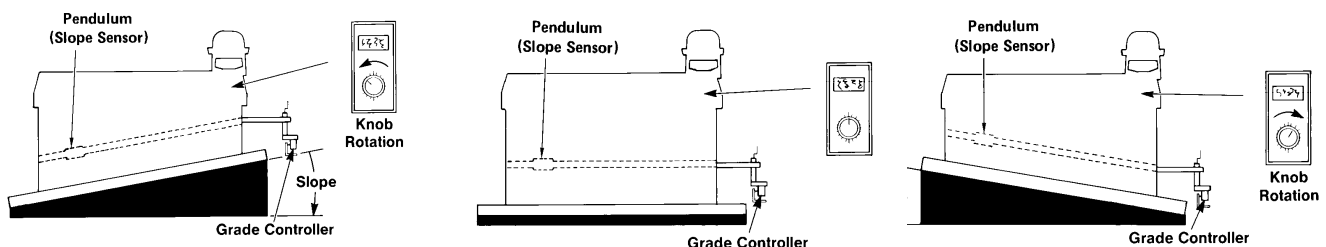

**Figure 85**

## Automatic Screed Control

### Remote Hand-Held Set Unit

The remote hand-held set unit has an LCD (Liquid Crystal Display) that registers in percentage of slope. An indicator in the upper left corner of the LCD shows whether the slope is positive or negative. An adjustment knob on the face of the unit is used to set the desired percentage of slope. When centered, turning the adjustment knob five turns in either direction is equivalent to 10% of slope. An adjustment is located on the bottom of the hand-held unit that facilitates changing the number readout when centering the unit. (Figure 86)

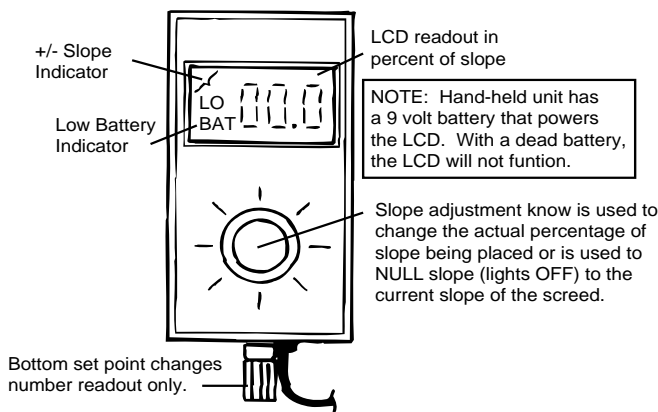

Figure 86

### Centering the Hand-Held Unit

Before using the slope system, the hand-held unit should be centered using the following procedure.

- 1) Put manual-setup-auto switch to **setup**.
- 2) Place run-standby switch on the amplifier unit to **standby**.
- 3) Turn adjustment knob clockwise until a definite **increase** in the amount of resistance is felt.
- 4) Note position of pointer on adjustment knob. If not pointing straight up, continue turning the knob clockwise until it points **straight up**.
- 5) Turn adjustment knob counterclockwise five turns.
- 6) Remove protective cap from bottom set point and adjust number set point until LCD reads 00.0.

### Slope Deadband

The deadband of the slope system refers to the amount the slope sensor (pendulum) can move without triggering a tow point cylinder response. A given amount of deadband is necessary to allow for normal machine vibration.

Set the deadband by removing the screw located on the face of the slope amplifier module. An adjustment screw is located under the face screw. Using the small screwdriver provided, clockwise rotation increases the amount of deadband; counterclockwise decreases the amount of deadband.

### Setting Deadband

- 1) Put manual-setup-auto switch to **setup**.
- 2) Place run-standby switch on amplifier unit to **standby**.
- 3) Turn adjustment knob on hand-held unit until both lights are **out**.
- 4) Turn the adjustment knob counterclockwise until a light just starts flashing. Turn the adjustment knob clockwise until the light just goes off. Note the reading on the LCD.
- 5) Turn adjustment knob clockwise until a light just starts flashing. Turn adjustment knob counterclockwise to the point where the light just goes off. Note reading on the LCD.
- 6) There should be a 00.2% reading between the numbers noted in steps 5 and 6.

System Four Settings

**Accessing System Four Performance Settings**

Continuously pressing the Auto/Manual/Survey (Cal) switch down while power the System Four on (selecting Elevation Control or Slope Control) allows access to the system performance settings. These settings are **Blank, Gain (elevation), Gain (slope), Units, Slope Resolution, Beeper, Hour Meter Deadband** and **Valve Offsets**.

When the performance setting menu is entered at startup, the arrows around the Grade Adjustment Knob will flash. Rotating the Grade Adjustment Knob clockwise scrolls the LCD display through the System Performance Settings in the order listed above. Releasing the Auto/Manual/Survey (Cal) switch while a particular performance setting is displayed will select that setting for adjustment.

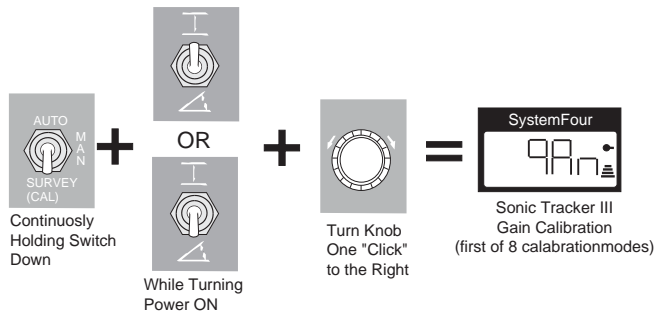

Continue to hold the Auto/Manual/Survey (Cal) switch down and turn the Grade Adjustment Knob one click at a time to access the other performance settings. Releasing the Auto/Manual/Survey (Cal) switch will display the current system settings. Turning the Grade Adjustment Knob one click at a time will change the setting.

- 1) **Blank Screen.** The blank screen will be the first setting displayed when entering the System Performance Settings and must be displayed to exit and save the system performance settings.
- 2) **Gain (Elevation).** This setting determines the speed at which System Four will cause the tow point cylinders to adjust to a change in elevation. **The typical Gain setting for the tracker is 25%.**

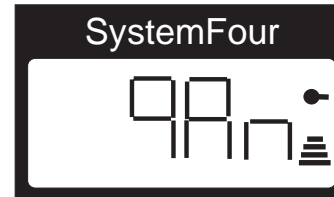

- 3) **Gain (Slope Control).** This setting determines the speed at which System Four will cause the tow point cylinders to adjust to a change in slope. **The typical Gain setting for the slope is 25%.**

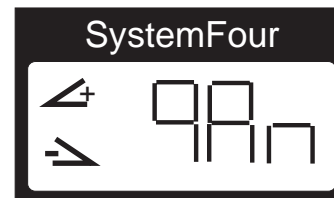

- 4) **Slope Resolution.** Sets display to read in increments of 0.1% or to 0.01%. **Slope resolution should be set to 0.1% (tenths) for paving applications.**

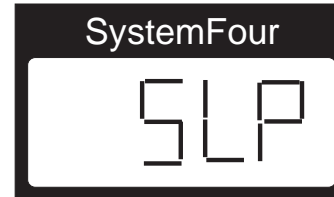

- 5) **Beeper.** Sets audible beep On or Off.

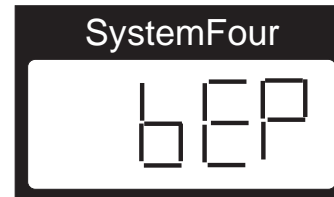

- 6) **Hour Meter.** Displays total and auto hours.

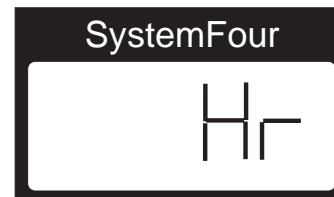

System Four Settings

- 7) **Deadband.** Sets on grade deadband. Deadband is the area of the working window that is on grade as simply means that while the reference is within that area, the paver's valves are idle (closed). Therefore, the wider the deadband (on grade area), the more a reference can move up or down without a correction being initiated. **Typical deadband setting is 003.**

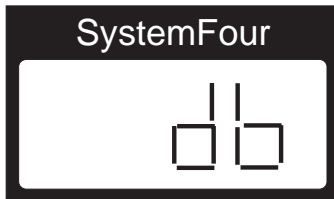

- 8) **Valve Offset.** The valve offset setting controls the duration of the signal sent to the paver valves from the control box. If the signal is too short in duration, the operator will hear the paver valve 'clicking' but the valve will not move. Likewise, if the signal is too long in duration, the valve will 'spring' wide open, causing the valve to jump and overcorrect.

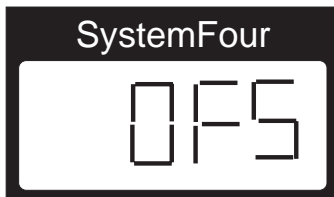

To set the valve offset, release the Auto/Manual/Survey (Cal) switch. The LED display will momentarily display the letters CAL and then go back to OFS.



Press the Auto/Manual/Survey (Cal) switch to survey (Cal) and release.

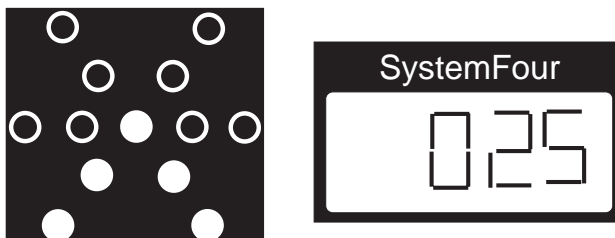

This causes the current offset in the up direction to be displayed and shows an UP light indicator. Turning the grade adjustment knob adjust the rate at which the tow point cylinder moves.

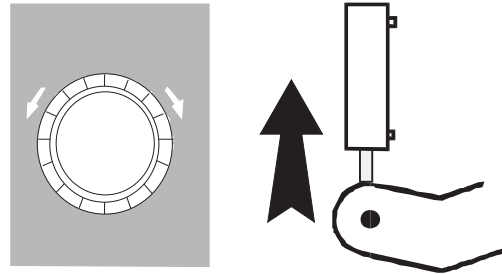

Adjust the grade knob until no cylinder movement is noted and then adjust to the point where a slight cylinder movement is noted. Press the Auto/Manual/Survey (Cal) switch to Survey (Cal) and release.

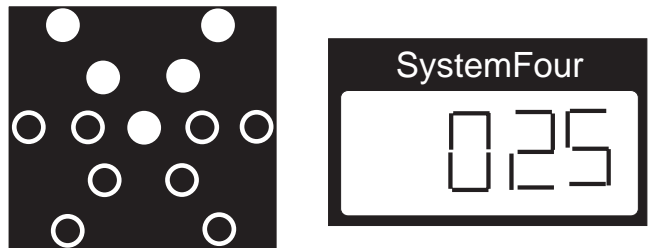

This causes the current offset in the up direction to be displayed and shows a DOWN light indicator. Turning the grade adjustment knob adjusts the rate at which the tow point cylinder moves.

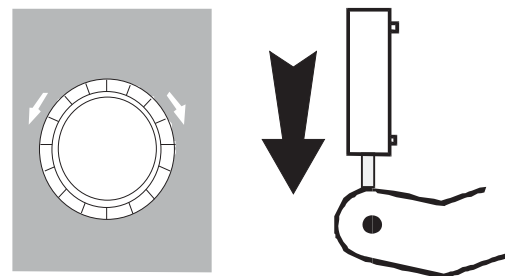

Adjust the Grade Knob until no cylinder movement is noted and then adjust to the point where a slight cylinder movement is noted.

After the desired values have been selected, press the Auto/Man/Survey (Cal) switch to Survey (Cal) and hold while turning the grade adjustment knob to the next performance setting.

System Four Settings

- 9) **Unit.** Sets display to read in feet, inches or centimeters. **The unit should be set to inches or centimeters.**



To exit and save the System Four performance settings, rotate the grade adjustment knob while holding the Auto/Man/Survey (Cal) switch in Survey (Cal) until the **blank screen is displayed**, then release the Auto/Manual/Survey (Cal) switch.

**Operational Checks**

- 1) Switch the Auto/Manual/Survey (Cal) switch to manual on both control boxes.



- 2) Place screed remote mat thickness Man/Setup/ Auto switches in setup on both sides of the screed.

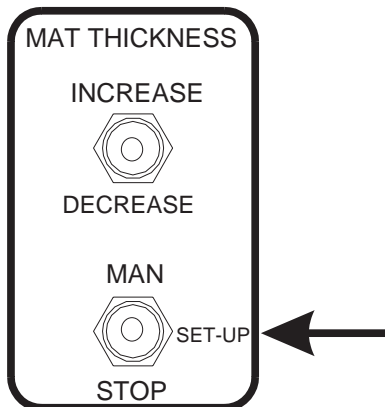

- 3) Switch the elevation power/off/slope power switch to slope.

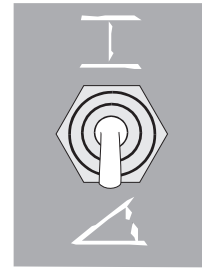

- 4) Adjust the grade adjustment knob on the control box in the direction indicated by the grade adjustment arrows until the on grade symbol illuminates.

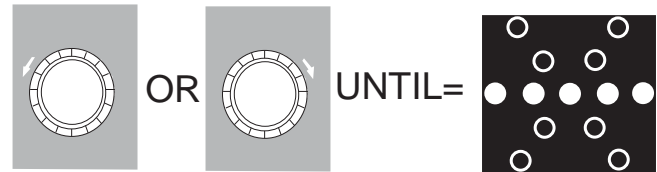

- 5) Switch the Auto/Manual/Survey (Cal) switch to auto.



- 6) Turn the grade adjustment knob on the control box one click clockwise.

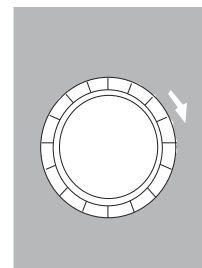

**Observe the following tow point cylinder reation:**

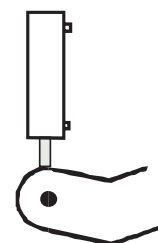

System Four Settings

The tow point cylinder should move to the new position and stop. If the tow point cylinder does not move, the valve offset performance setting for that direction of cylinder movement is too slow and needs to be increased.

If the tow point cylinder jumps a large distance and has to come back before stopping, the valve offset performance setting for that direction of cylinder movement is too fast and needs to be decreased.

- 7) Turn the grade adjustment knob on the control box one click counterclockwise.

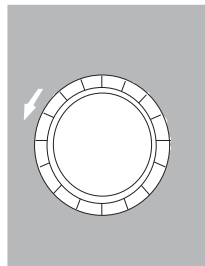

**Observe the following tow point cylinder reaction:**

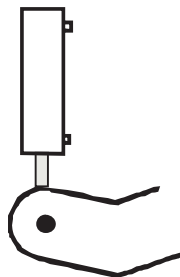

The tow point cylinder should move to the new position and stop. If the tow point cylinder does not move, the valve offset performance setting for that direction of cylinder movement is too slow and needs to be increased.

If the tow point cylinder jumps a large distance and has to come back before stopping, the valve offset performance setting for that direction of cylinder movement is too fast and needs to be decreased.

**If necessary, adjust valve offset performance settings and repeat operational checks.**

Before dealing with sensor location in relation to

## Basic Sensor Principles

Before dealing with sensor location in relation to screed reaction, it is important to understand how a grade or slope system actually controls the angle-of-attack on the screed.

A grade sensory system uses an electronic sensor that maintains a set elevation (or null point) in relation to a reference. If anything causes the sensor to deviate from that null point, an electrical signal is sent to the tow point solenoid valve, causing the tow point cylinder to raise or lower to reestablish the null point at the sensor. When the tow point is raised, it increases the angle-of-attack on screed, causing the screed to increase depth. When the tow point is lowered, it decreases the angle-of-attack on the screed causing screed to decrease depth. (Figure 87)

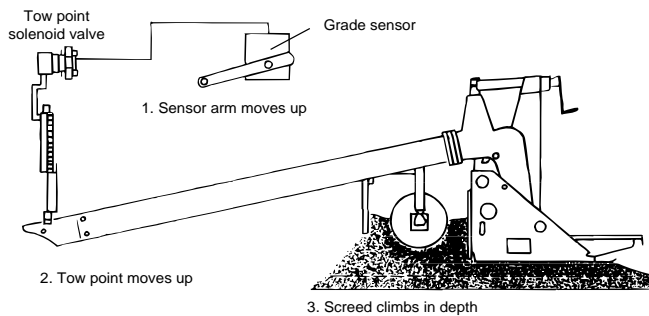

**Figure 87**

A slope sensory system uses an electronic sensor that maintains a set angle (or null point) in relation to the horizon. If the sensor deviates from that null point, an electrical signal is sent to the tow point solenoid valve, causing the tow point cylinder to raise or lower to reestablish the null point at the sensor. When the tow point is raised, it increases the angle-of-attack on the screed, causing the screed to increase depth. When the tow point is lowered, it decreases the angle-of-attack on the screed causing screed to decrease depth. (Figure 88)

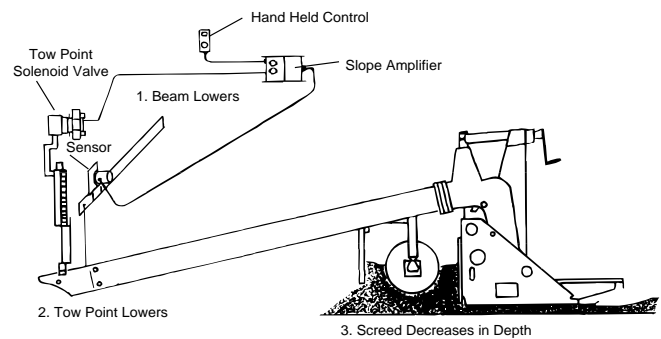
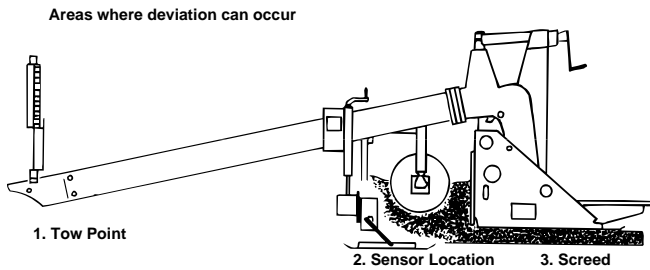

**Figure 88**

## Sensor Positioning

The position of the sensor on the tow arm determines how fast the screed will react to a change of the null point at the sensor, thus, affecting either the profile or the rideability. Evaluate job specifications and grade-related conditions to determine the desired mounting position that will produce the required results. (Refer to Building Profile, Rideability or Evaluation of Jobs.)

When working with automation, there are three variables that affect the automation and/or position of the screed: tow point deviations, screed deviations and sensor location. It is important to understand how the automation reacts differently to a given deviation in each of these areas. (Figure 89)

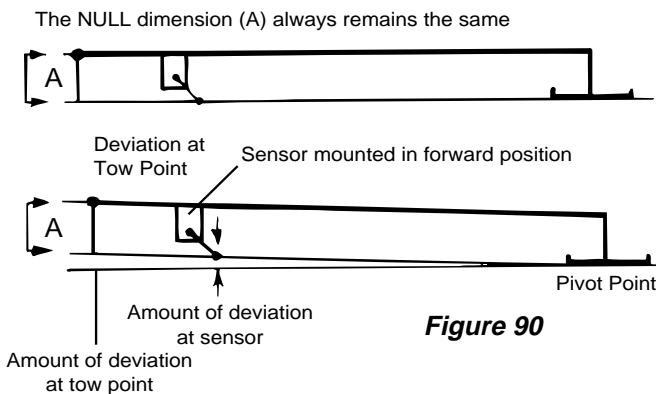

**Figure 89**

**Tow Point Deviation**

Tow point deviations are caused by the paver moving over irregular grades.

Figure 90 shows a deviation at the tow point, with the sensor mounted in a forward position. With sensor mounted forward, the amount of deviation at the sensor is approximately the same as the amount of deviation at the tow point. The distance the tow point cylinder would have to travel to reestablish the original null point would be approximately the same as the tow point deviation. In effect, the sensor anticipates the error at the screed and corrects for it before it occurs.

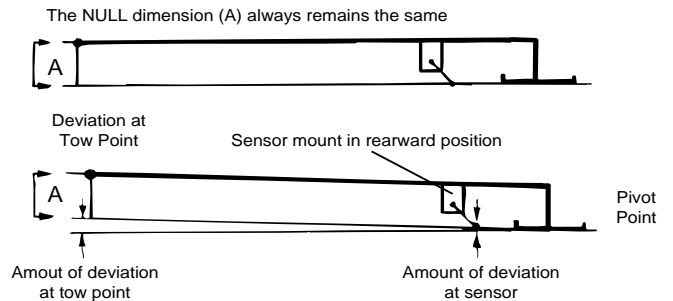

**Figure 90**

Figure 91 shows a deviation at the tow point, with the sensor mounted in a rearward position. With sensor mounted rearward, the amount of deviation at the sensor is small enough that it does not exceed the deadband width of the sensor. The sensor will not react immediately to the tow point deviation.

Areas Of Deviation

However, the screed will start to climb due to the increase in the angle-of-attack. When the screed climbs enough to exceed the deadband width of the sensor it will then react. The sensor does not pick up the error at the screed until it affects the screed.



**Figure 91**

**Screed Deviation**

Screed deviations are caused by screed settling, variations in paving speed, head of material, adjustment of hand cranks, and grade conditions. Figure 92 shows a deviation at the screed with the sensor mounted in a forward position. With the sensor mounted forward, the amount of deviation at the sensor is small enough that it does not exceed the dead band width of the sensor. Therefore the sensor will not react immediately to the screed deviation. When the screed climbs far enough to exceed the deadband width of the sensor, it will then react.

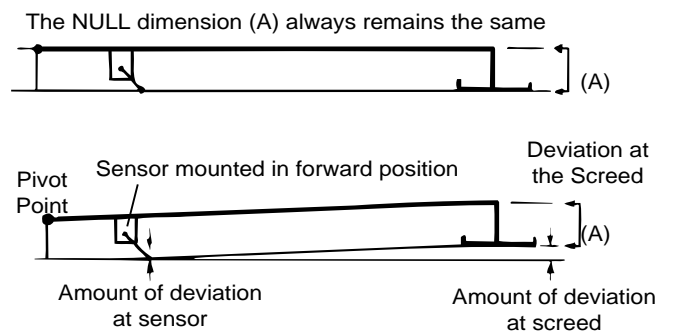

**Figure 92**

Areas Of Deviation

Figure 93 shows a deviation at the screed, with the sensor mounted in a rearward position. With the sensor mounted rearward, the amount of deviation at the sensor is approximately the same as the amount of deviation at the screed. The distance the tow point cylinder would have to travel to reestablish the original null point would be more than the amount of deviation at the screed.

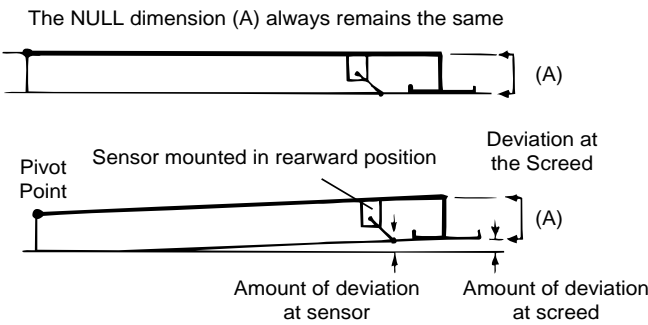

**Figure 93**

**Sensor Deviation**

Sensor deviation is caused by manual adjustment (changing the sensor setting), loose or flexing sensor mounts, or changes in the reference. Figure 94 shows a deviation at the sensor with the sensor mounted in a rearward position. With the sensor mounted rearward, the distance the tow point cylinder would have to travel to reestablish the null point would be more than the amount of deviation at the sensor.

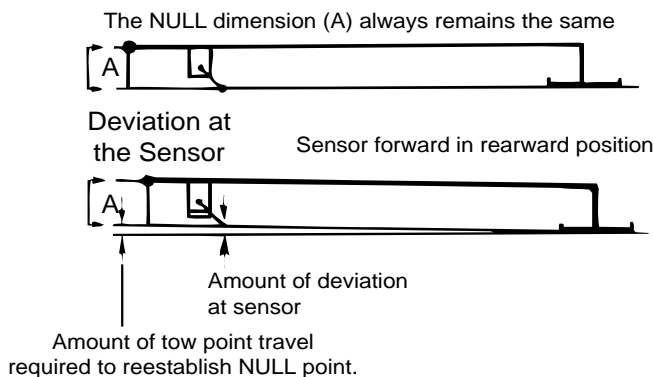

**Figure 94**

Figure 95 shows a deviation at the sensor, with the sensor mounted in a forward position. With the sensor mounted forward, the distance the tow point cylinder would have to travel to reestablish the null point would be approximately the same as the amount of deviation at the sensor.

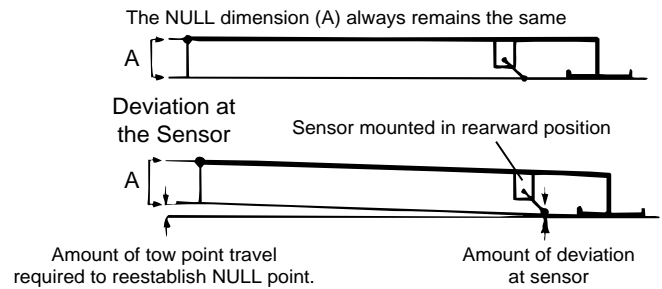
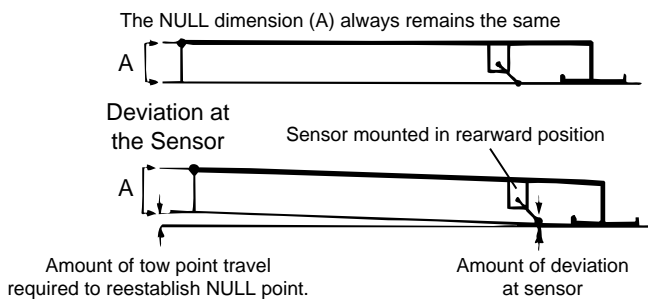

**Figure 95**

The location of the sensor determines how it affects the screed. By mounting the sensor in different places, the screed will build either for profile or for rideability. The following section describes some common paving situations and how different sensor systems affect them.

**Effective Length of Tow Arm**

Automation sensors always move the tow point up or down to maintain the sensor’s null point. The location of the sensor becomes our control point. The tow point becomes a point to raise or lower the tow arm to reestablish the null point at the sensor. The effective length of tow arm becomes the distance between the control point (sensor) and the pivot point (trailing edge of the screed). Because the screed must travel five tow arm lengths to fully react to a correction. Shortening the effective tow arm length shortens the distance the paver must travel to complete a correction, increasing reaction time. Moving the sensor towards the screed increases reaction time (builds profile), while moving the sensor towards the tow point decreases reaction time (builds rideability). (Figure 96)



**Figure 96**

**Screed Mounting**

**Never mount** the grade sensor any closer to the screed than  $\frac{3}{4}$  of the way back from the tow point. Mounting at the screed results in very unstable reactions to sensor deviations. (Figure 97)

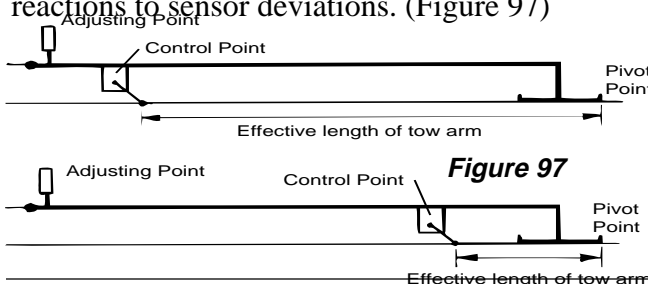

**Figure 97**

**Sensor Location with Respect to Screed Reaction**

Figure 98 shows the unstable screed reactions in relation to tow point movement, caused by the grade sensor being mounted too close to the screed.

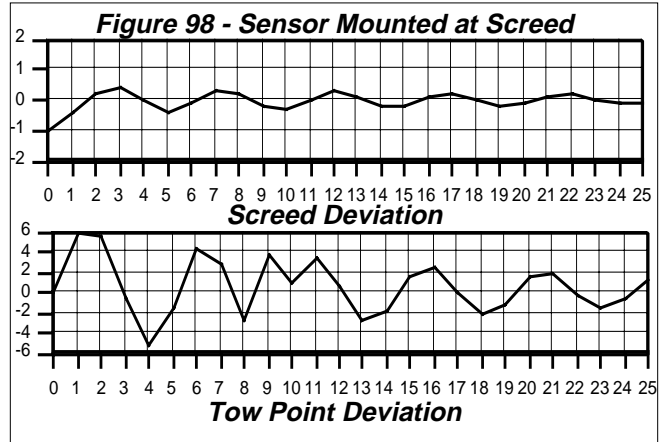

**Grade Control for Joint Matching**

Joint matching is matching the height of a mat being placed next to an existing mat or curb. This requires the screed to be very responsive to changes in the elevation of the existing mat or curb. This is an application where we are building “Profile”, or over-correcting the screed, forcing it change depth in a very short distance.

The grade sensor should be mounted  $\frac{3}{4}$  of the way back from the tow point or just ahead of the augers. (Figure 99)

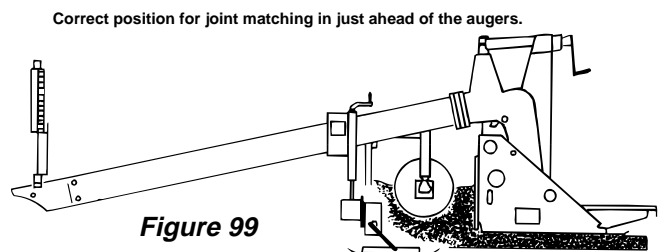

**Figure 99**

With the sensor mounted in the rearward position, any change to the null point of the sensor will cause a magnified change of the tow point position in order to reestablish the null point.

The magnified change at the tow point is greater than that required for the screed to achieve the desired depth, but is necessary if the screed is to achieve the desired depth quickly. The screed continues to change depth due to the magnified change in the tow point. As the screed continues to change depth, it in turn causes a change in the null point. The grade

sensor detects this change and relocates the tow point position to again reestablish the null point.

With the sensor mounted close to the screed, it is very responsive to any deviation in the screed's position, though not very responsive to deviations of the tow point position, caused by the tractor traveling over irregular grades. Therefore it does not anticipate these deviations. It can only react when a deviation of the tow point position affects the position of the screed.

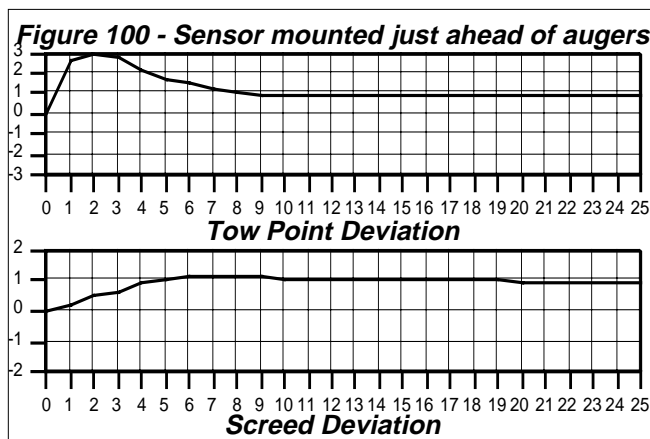

In Figure 100, the tow point rises very quickly in the first two feet of travel, while the screed takes six feet of travel to respond to the tow point movement. The sensor detects that the screed has risen to the correct level at about three feet of travel and starts bringing the tow point back down. The tow point stabilizes at about nine feet of travel. The screed finally stabilizes at about seventeen feet of travel. We want to note that the screed exceeds the desired level from about four feet of travel to about seventeen feet of travel. This is primarily due to the over-correction of the tow point and screed reaction time.

From the standpoint of building profile, as a major change is introduced, the screed responds very quickly to that change as desired. From the standpoint of rideability, this creates a bump that traffic would feel. When building profile (joint matching), the screed reacts quickly to deviations at the sensor.

## Sensor Location with Respect to Screed Reaction

### Grade Control for Fixed Stringline

When using automation off an established or fixed stringline, it requires the screed to be very responsive to any changes in elevation of the stringline. This is an application where we are building “profile”, or over-correcting the screed and forcing it to change depth in relation to the elevation of the stringline.

The grade sensor should be mounted  $\frac{3}{4}$  of the way back from the tow point, or just ahead of the augers. (Figure 101)

With the sensor mounted in the rearward position, any change to the null point of the sensor will cause a magnified change of the tow point position, to reestablish the null point.

Correct sensor position for string line is just ahead of augers.

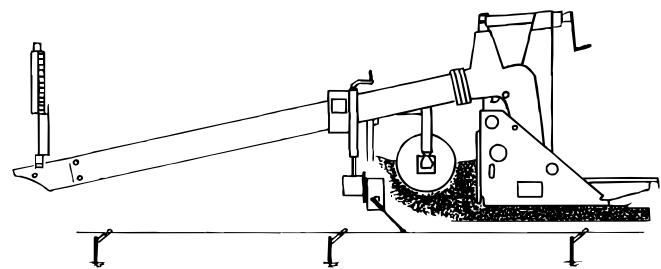

**Figure 101**

The magnified change at the tow point is greater than that required for the screed to achieve the desired depth, but is necessary if the screed is to achieve the desired depth quickly. As the screed continues to change depth due to the magnified change in the tow point, it in turn causes a change in the null point. The grade sensor detects this change and relocates the tow point to again reestablish the null point.

With the sensor close to the screed, it is very responsive to any deviation in the screed position, though not very responsive to deviations of the tow point position, caused by the tractor traveling over irregular grades. Therefore, it does not anticipate these deviations. It can only react when a deviation of the tow point affects the position of the screed. Refer to Screed Deviations and Tow Point Deviation.

The accuracy of profile and smoothness of the mat being placed is dependent on the accuracy of the stringline. If a stringline is established with sags in the stringline between pins, the produced mat will have the same high points at the pins and sags between pins. Extremely irregular grade conditions can also affect the profile and smoothness of the mat. Pre-leveling should be considered if these conditions exist. Refer to Pre-Leveling Grade. (Figure 102)

**Figure 102**

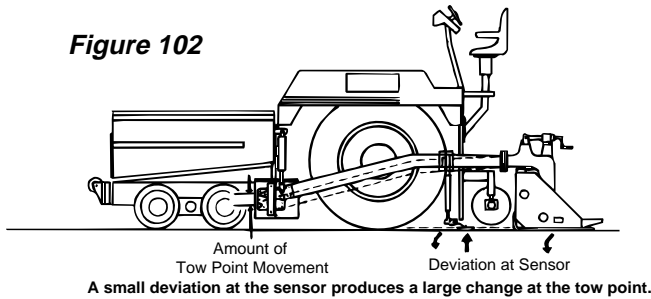

In figure 103, the tow point rises very quickly in the first two feet of travel, while the screed takes six feet of travel to respond to the tow point movement. The sensor detects the screed has risen to the correct level at about three feet of travel and starts bringing the tow point back down. The tow point stabilizes at about nine feet of travel. The screed finally stabilizes at about seventeen feet of travel. Note that the screed exceeds the desired level from about four feet of travel to about seventeen feet of travel. This is primarily due to the over-correction of the tow point and screed reaction time.

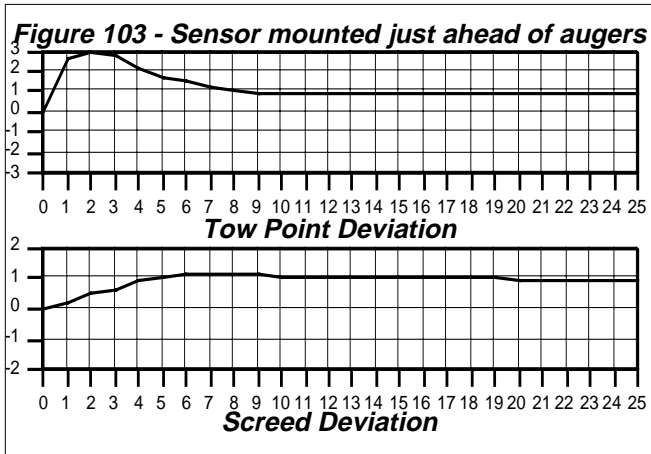

From the standpoint of building profile, when a major change is introduced in the stringline, the screed responds very quickly to that change as

### Sensor Location with Respect to Screed Reaction

desired. From the standpoint of rideability, this creates a bump that traffic would feel. When building profile (running off a fixed string line), the screed reacts quickly to deviations at the sensor.

### Grade Control for a Ski

When using automation off a ski, corrections to deviations that occur at the sensor or the screed will require the paver to travel approximately 5 lengths of the tow arm before the correction is fully completed. Deviations that occur at the tow point, due to the tractor traveling over irregular grades, are corrected for immediately. In effect, the sensor is correcting for deviations at the tow point before they can affect the screed's angle-of-attack (position). In this application we are building "Rideability", or averaging all required changes in depth over a longer area.

The grade sensor should be mounted 1/4 of the way back from the tow point. (Figure 104)

Correct sensor position for using ski is 1/4 back from the tow point

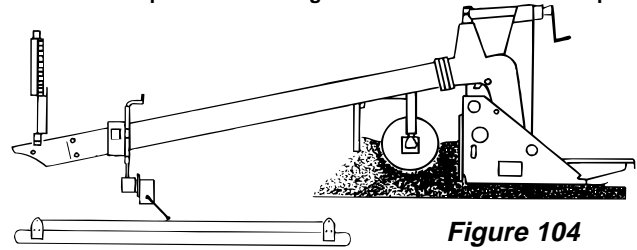

With the sensor mounted in the forward position, any deviation at the tow point caused by the tractor traveling over irregular grades will cause the sensor to react immediately, to correct for that deviation. The sensor therefore maintains the same tow point position (angle-of-attack on the screed) in relation to the reference (ski), regardless of the grade irregularities.

When the tractor rises and falls while traveling over irregular grades, the tow point position in relation to the ski remains unchanged. Therefore the angle-of-attack on the screed is unchanged. Deviations at the tow point that would have affected the position of the screed are anticipated and corrected before they affect the screed's position.

With the sensor close to the tow point, it is very responsive to any deviations in the tow point position,

though it is not very responsive to deviations at the screed caused by screed settling, variations in paving speed, head of material, adjustment of hand cranks or grade conditions.

When a deviation occurs at the screed and is large enough to exceed the deadband width of the sensor, the tow point is repositioned to reestablish the null point of the sensor. The distance the tow point must travel to reestablish the null point of the sensor is very small. If the screed continues to change, the sensor will move the tow point in small increments as needed to maintain the sensor null point. All of this takes place over a long distance of travel. Therefore all changes are averaged over a long distance, producing a smooth rideable surface (building “rideability”). (Figure 105)

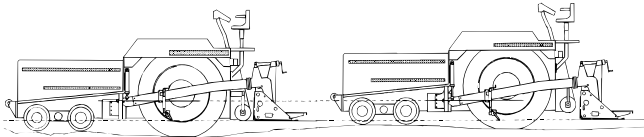

**Figure 105 -Tow point remains the same as tractor travels over irregular grades.**

As we see in Figure 106, a deviation at the tow point is corrected for before it affects the angle-of-attack on the screed. Therefore no change occurs at the screed, thus producing a smooth uniform mat.

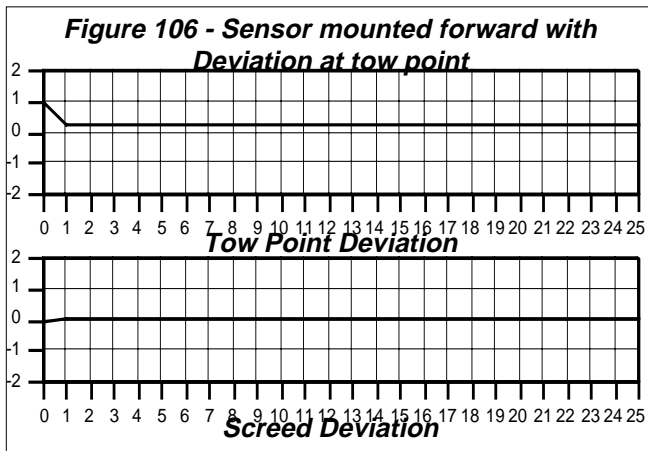

As we see in Figure 107, a deviation has occurred at the screed due to screed settling, variations in paving speed, head of material, adjustment of hand cranks or grade conditions. With the grade sensor mounted forward, the amount of deviation did not exceed the deadband width of the sensor, and no tow point movement was called for. The screed will reestablish

### Sensor Location with Respect to Screed Reaction

its original position after traveling approximately five lengths of the tow arm, thereby averaging the deviation over a long area for rideability.

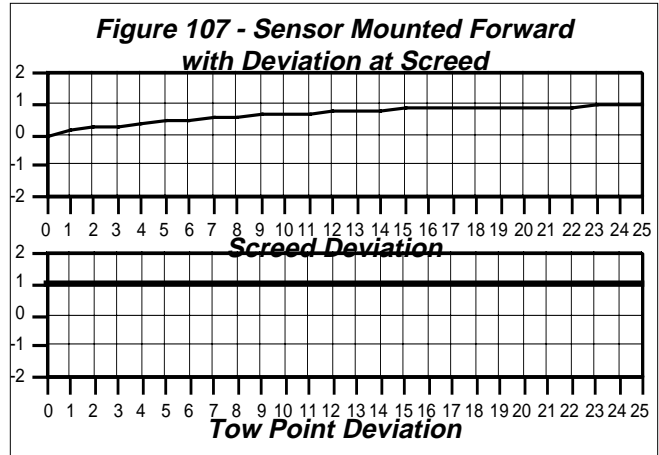

### Types of Skis

A ski provides an independently stable reference that floats over irregular grades while being towed alongside the tractor. The grade sensor utilizes this reference to maintain the position of the tow point in relation to the reference (ski). By maintaining the tow point position in relation to the ski, the normal rise and fall of the tractor as it travels over irregular grades will not affect or change the angle-of-attack on the screed.

A ski is capable of flexing as it travels over depressions or high points in the grade and still provide an unchanging reference. As a rule, the longer the ski, the better the reference, as a longer ski is capable of bridging over longer depressions without changing the reference point.

The **standard ski** comes in 10 foot lengths and can be assembled to provide a 20 foot, 30 foot, or 40 foot reference system. As mentioned earlier, the longer the ski, the better the reference, as a longer ski is capable of bridging over longer depressions without changing the reference point. (Figure 108)

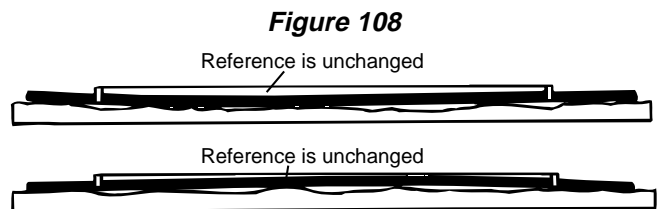

**Figure 108**

The standard ski should always be mounted as close to the screed as possible, as this is the control point from which the depth of material is established. Also by mounting in as close as possible, there will be less chance of deflection due to loose mounting hardware. If wide width paving is performed, an optional wide mat reference system can be installed that provides a stable mounting system for extended width paving.

The **over-the-screed** ski is the preferred reference system when laying a wide mat or where job conditions will not permit running a ski beside the screed. By running the ski over the screed, the reference system is mounted in close to the tractor where it can respond to grade deviations without being affected by problems caused by flexing mounting hardware. (Figure 109)

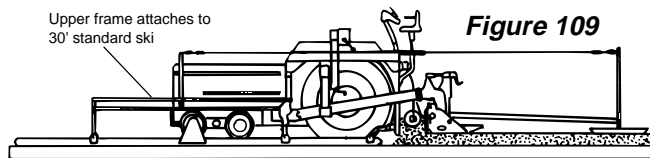

**Figure 109**

The over-the-screed reference system can be used on finish or surface mats without leaving undesirable trailing marks in the mat. Once the skid plate is warmed up to the temperature of the material being placed, it lightly skims over the surface of the mat being placed without leaving marks that would show up even after rolling.

## Sensor Location with Respect to Screed Reaction

### Traveling Stringline (*Do Not Use*)

A traveling string line is not recommended since it is not capable of bridging or floating over grade irregularities without introducing a deviation at the sensor. A traveling string line is supported by only two points. As it travels over irregular grades it causes the automation to react to every depression and bump. (Figure 110) In effect it relocates the original deviation farther down the road, but does not remove them.

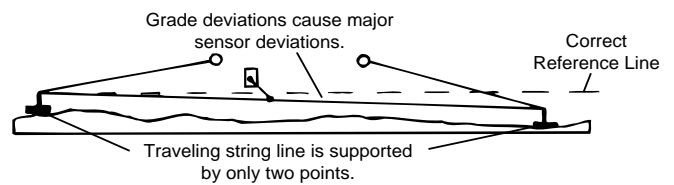

**Figure 110**

## Slope Control System

The slope system consists of a slope sensor (pendulum), an amplifier, and a hand-held set unit. The slope sensor provides an angular reference in relation to the horizon for controlling the percentage of slope on the mat being placed.

The most common problem incurred when using slope control is the conflict of job specifications for percentage of slope and yield. Many job specifications will require a mat be placed at an exact percentage of slope over very irregular sloping grades. The conflict comes in when the depth of material in a specific area becomes thicker to maintain the desired slope and specifications will not allow for the extra material required. When these conflicts exist, a paver crew has to constantly override or reset the percentage of slope in an attempt to meet depth or yield specifications. The mat being produced will not meet specifications for slope, and the smoothness or “rideability” of the mat is greatly reduced by the frequent changes in slope that introduced. In these conditions, pre-leveling of extremely irregular sloping areas is recommended. Refer to Pre-Leveling.

### Sensor Positioning

The position of the sensor can be mounted on either the forward cross beam or on the rearward cross beam. The mounting position determines how fast the screed will react to a change of the null point at the sensor, therefore building profile or rideability. Evaluate job specifications and grade-related conditions to determine the desired mounting position that will produce the required results. Refer to Building Profile, Rideability or Evaluation of Jobs.

### Building For Rideability

With the sensor mounted on the forward cross beam, corrections to deviations at the screed will require

the paver to travel approximately 5 lengths of the tow arm before the correction is fully completed. Deviations that occur at the tow point, (due to the tractor traveling over irregular grades) are corrected for immediately. In effect, the sensor is correcting for deviations at the tow point before they can affect the screed’s angle-of-attack (position). In this application we are building “Rideability”, or averaging all required changes in depth over a longer area.

With the sensor mounted in the forward position, any deviation at the tow point caused by the tractor traveling over irregular grades will cause the sensor to react immediately to correct for that deviation, therefore maintaining the same tow point position (angle-of-attack on the screed) in relation to the angle of the cross beam, regardless of the grade irregularities. (Figure 111)

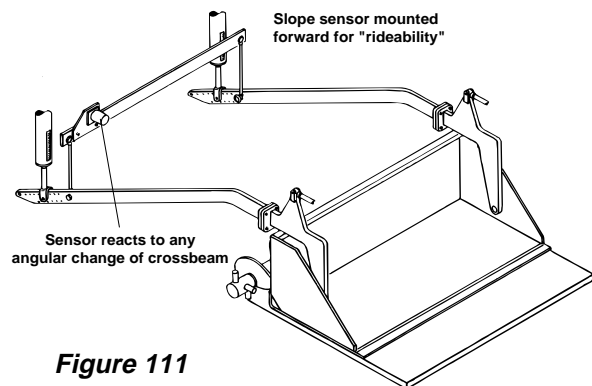

Figure 111

When the tractor rises and falls while traveling over irregular grades, the tow point position in relation to the angle of the cross beam remains unchanged, therefore not changing the angle-of-attack on the screed. Deviations at the tow point that would have affected the position of the screed have been anticipated and corrected before they affect the screed’s position. (Figure 112)

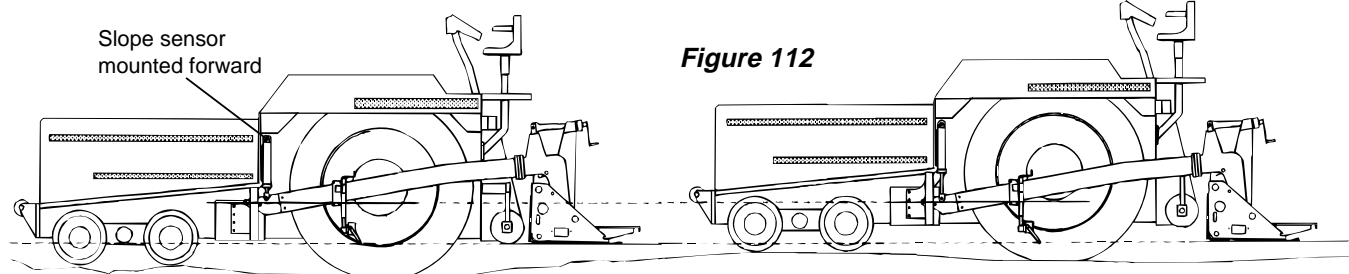

Figure 112

Tow point position remains the same as the tractor travels over irregular grades.

Slope Control System

With the sensor close to the tow point, it is very responsive to deviations in the tow point, though not very responsive to deviations at the screed caused by screed settling, variations in paving speed, head of material, adjustment of hand cranks, or grade conditions. When a deviation in slope occurs at the screed and exceeds the deadband width of the sensor, the tow point is repositioned to reestablish the null point or original angle of the sensor. The distance the tow point must travel to reestablish the null point of the sensor is very small. If the screed continues to change in slope, the sensor will move the tow point in small increments as needed to maintain the sensor null point. All of this takes place over a long distance of travel therefore all changes are averaged.

As seen in Figure 113, a deviation at the tow point caused by the tractor traveling over irregular grades is corrected before it affects the angle-of-attack on the screed. Therefore no change occurs at the screed, thus producing a smooth uniform mat, but not necessarily the exact percent of slope at any given point in the mat.

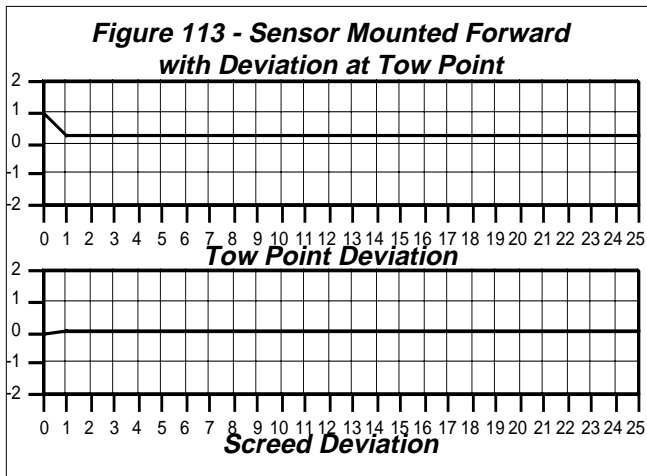
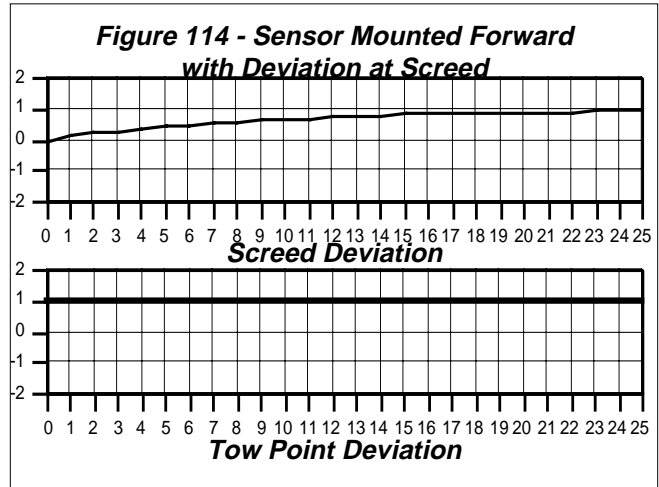

Figure 114 shows that a deviation has occurred at the screed (due to screed settling, a variation in paving speed, head of material, adjustment of hand cranks, grade condition and etc.) With the grade sensor mounted forward the amount of deviation did not exceed the deadband width of the sensor, so no tow point movement was called for. The screed reestablished its original position after traveling approximately 5 lengths of the tow arm, thereby averaging the deviation over a long area for

rideability. However, it did not necessarily maintain an exact percentage of slope at any given point in the mat.



**Building For Profile**

With the sensor mounted on the rearward cross beam, the screed is very responsive to any changes in the percentage of slope of the screed. This is an application where we are building profile, or over-correcting the screed, forcing it to change depth in a very short distance. (Figure 115)

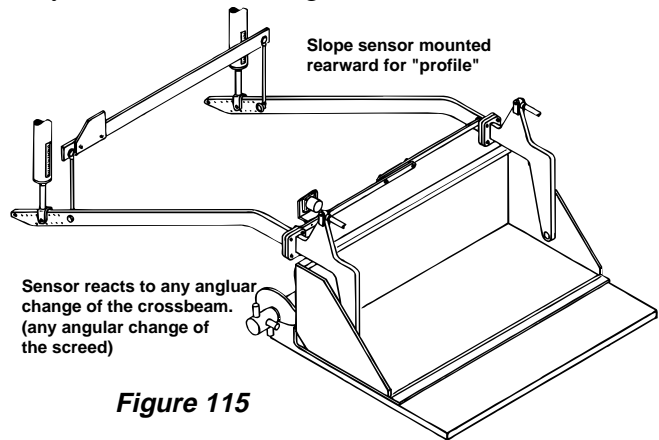

With the sensor mounted in the rearward position, any change to the null point of the sensor will cause a magnified change of the tow point position in order to reestablish the null point.

The magnified change at the tow point is greater than that required for the screed to achieve the desired depth, but is necessary if the screed is to achieve the desired depth quickly. The screed continues to

Slope Control System

change depth due to the magnified change in the tow point. As the screed continues to change depth, it in turn causes a change in the null point. The grade sensor detects this change and relocates the tow point position to again reestablish the null point.

With the sensor mounted close to the screed, it is very responsive to any deviation in the slope of the screed, though not very responsive to deviations of the tow point position caused by the tractor traveling over irregular grades. Therefore it does not anticipate these deviations, it can only react when a deviation of the tow point position affects the position of the screed. (Figure 116)

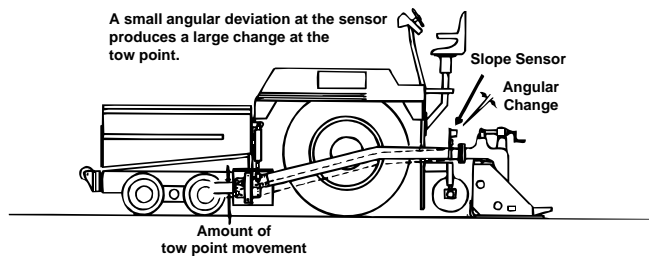

**Figure 116**

As seen in the graphs, the tow point rises very quickly in the first two feet of travel, while the screed takes six feet of travel to respond to the tow point movement. The sensor detected the screed had risen to the correct level at about three feet of travel and started bringing the tow point back down. It stabilized at about nine feet of travel. The screed finally stabilizes at about seventeen of travel. Note that the screed exceeded the desired level from about four feet of travel to about seventeen feet of travel. This is primarily due to the over-correction of the tow point and screed reaction time. (Figure 117)

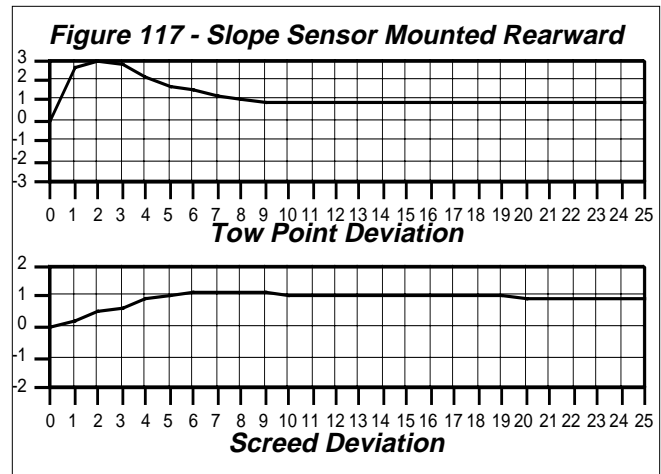

From the standpoint of building profile, introducing a major change in the slope setting and makes the screed respond very quickly to that change as desired. From the standpoint of rideability, a bump was just created that traffic will feel. To summarize, when building profile (with the slope sensor mounted to the rear), the screed reacts quickly to deviations at the sensor (or when the slope setting is changed at the hand set unit).

When using the slope control system in combination with a grade control, it is important to understand how the two react to each other. The location of the sensors determines how each system reacts not only to deviations at the tow point, screed and sensor of each system but also how the slope system reacts to the changes introduced by the grade system.

### **Ski and Slope (Sensor Forward)**

When a combination of ski and slope are utilized, mounting both grade and slope sensors forward results in better rideability. If a deviation occurs at the tow point on the side being controlled by the grade sensor, the grade sensor reacts immediately to reestablish the original tow point position in relation to the ski. Therefore the angle of the cross beam remains unchanged and the slope sensor does not react. If a deviation occurs at the tow point on the side being controlled by the slope sensor, the slope sensor reacts immediately to reestablish the original angle of the cross beam. In effect the slope control maintains the tow point position much like the grade control system does when run off a ski. This combination of grade and slope will anticipate deviations that would occur at the screed and corrects for them before they occur. Refer to Tow Point Deviation with sensor mounted forward.

With the sensors close to the tow point, they are very responsive to any deviations in the tow point's position, though not very responsive to deviations at the screed caused by screed settling, variations in paving speed, head of material, adjustment of hand cranks, grade conditions, etc. Refer to Screed Deviation with sensor mounted forward.

### **Ski and Slope (Sensor Rearward)**

When utilizing a slope sensor (mounted rearward) with a ski, the grade system builds rideability while the slope system corrects for change at the screed. Refer to Tow Point Deviation with sensor mounted rearward. This combination is not overly responsive to irregular grades, but will even out deviations, providing rideability. It is, however, very responsive to deviations of slope at the screed. If a deviation occurs at the screed, the sensor will cause a large change of the tow point position to reestablish the null point of the slope sensor. Refer to Screed Deviation with sensor mounted rearward.

## Reactions (Combinations of Grade and Slope)

### **Joint Matcher and Slope (Sensor Forward)**

When combining a slope sensor (mounted forward) and a joint matcher (with the grade sensor mounted rearward) the grade system builds profile while the slope system builds rideability.

If a deviation occurs at the tow point on the side controlled by the slope sensor, the slope sensor reacts immediately to reestablish the original angle of the cross beam, maintaining the tow point position. Therefore it anticipates deviations that would occur at the screed and corrects for them before they occur. Refer to Tow Point Deviation with sensor mounted forward. With the slope sensor close to the tow point, it is very responsive to any deviations in the tow point position, though not very responsive to deviations at the screed, caused by screed settling, variations in paving speed, head of material, adjustment of hand cranks, grade conditions, etc. Refer to Screed Deviation with sensor mounted forward.

If a deviation occurs at the grade sensor, the sensor will cause a large change of the tow point position on the grade side to reestablish the null point of the grade sensor. Refer to Screed Deviation with sensor mounted rearward. This large change of the tow point position on the grade side in turn changes the angle of the cross beam. The slope sensor detects this and changes the tow point position on the slope side an equal amount in the same direction to reestablish the null point of the slope sensor. In effect, a small deviation at the grade sensor has caused a magnified change of both grade and slope tow points. Refer to Sensor Deviation with sensor mounted rearward.

### **Joint Matcher and Slope (Sensor Rearward)**

When combining a slope sensor (mounted rearward) and a joint matcher (with the grade sensor mounted rearward) both the grade and slope systems build profile. If a deviation occurs at the grade sensor, the sensor will cause a large change of the tow point position on the grade side to reestablish the null point of the grade sensor. Refer to Sensor Deviation with sensor mounted rearward. The slope sensor will not react to the deviation at the grade sensor

until the change that was introduced to the grade side tow point causes a change at the screed. Then it will also introduce a large change in the tow point position on the slope control side. Refer to Screed Deviation with sensor mounted rearward. If a deviation occurs at the screed, the slope sensor will cause a large change of the tow point position on the slope side to reestablish the null point of the slope sensor. Refer to Screed Deviation with sensor mounted rearward.

## Reactions (Combinations of Grade and Slope)

When the slope and grade sensors are mounted rearward, they are not very responsive to deviations at the tow points caused by the tractor traveling over irregular grades. They can only react after a tow point deviation has caused a change at the screed. Refer to Tow Point Deviation with sensor mounted rearward.

**SMOOTHTRAC™**  
Sonic Averaging System (SAS)

**SMOOTHTRAC™**  
**Sonic Averaging System (SAS)**

SmoothTrac™ incorporates proven Sonic Tracker® technology with special software to completely eliminate the need for contact type skis on road machines.

SmoothTrac™ can be adapted to all brands of pavers and profilers and can be made compatible with existing Topcon System IV Paver Systems components with a simple software upgrade.

The non-contact design allows full maneuverability of paver and profilers, and turn around or back up without removing or lifting the beam. With the single knob mat thickness control in hundredths of a foot from the screed platform, this allows the operator greater control of material.

Quick and easy setup and storage on the paver eliminates the loss or damage to the ski during transport or changing to joint matching.

The beam can be setup to “over the screed” reference without adding large and awkward sections to the beam.

**NOTE:** When adding SmoothTrac™ to an existing paver control system, be sure the existing system is upgraded with SAS software on both the control boxes and the trackers being used. (See Control Box Setup Rev Info on page 67)

**Beam Layout**

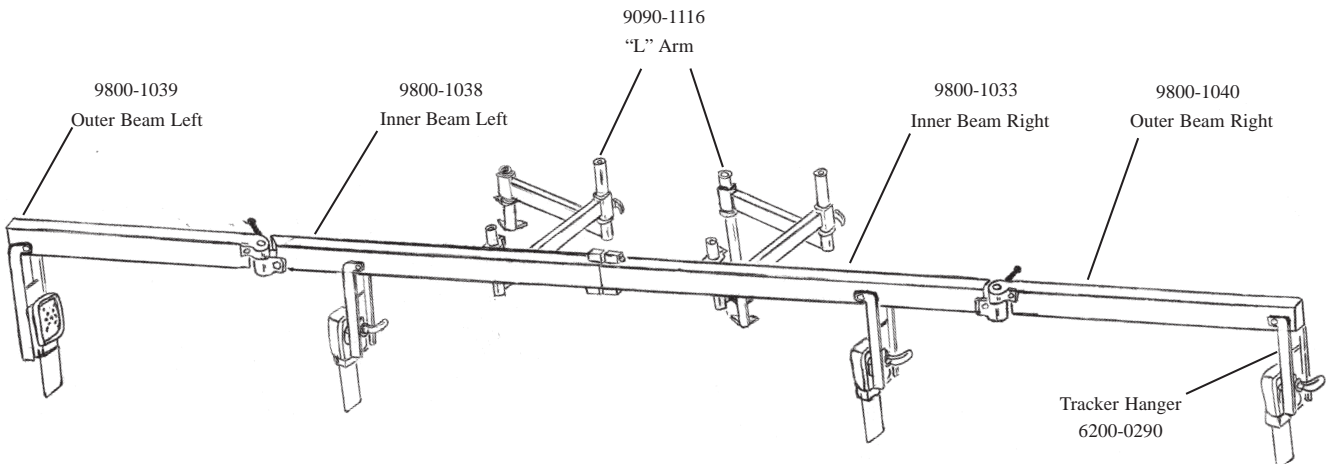

## SMOOTHTRAC™

### Sonic Averaging System (SAS)

## Safety Precautions

1. Read and become familiar with the manufacturer's operations manual, including safety information before installing or using Topcon System Four.
2. Working around heavy construction equipment can be dangerous. Always use extreme caution on the job site.



**Warning** - Do not stand or sit on machine parts meant for operation.

3. The mandrel should be grounded before working on or around the paver.
4. Do not attach System Four components to the paver while the engine is running.
5. Do not allow any System Four component to limit the visibility of the operator in an unsafe manner.
6. Use tie-wraps supplied with System Four to keep hoses and wires secured and away from wear or pinch joints.
7. Use eye protection when welding, cutting, or grinding is being done on the machine.
8. Hydraulic lines can be under extreme pressure even when the machine is turned off. When working on or near hydraulic lines, protect yourself at all times and wear protective clothing.



**Warning** - Relieve all pressure in the hydraulic lines before disconnecting or removing any lines, fittings, or related components. If injury does occur, seek medical assistance immediately. Consult the profiler OEM Operator's Manual for details.

9. When using laser control, avoid direct exposure to your eyes.



**Caution** - Do not stare into the laser beam or view the beam directly with optical equipment.

10. When welding, always use appropriate welding precautions and practices. Use shielding to prevent onlookers from staring into the light.
11. After welding, all affected areas should be painted with a rust inhibitor.

**Notice** - Disconnect all Topcon system electrical cables prior to welding on the machine.



**Warning** - Do not weld near hydraulic lines or on any equipment when in operation.

**Notice** - All mounting bracket welds must be secure and strong to prevent the sensor equipment from vibrating excessively or from becoming detached at the weld during operation.

**Notice** - Keep the carrying case dry at all times. Do not allow moisture to get inside the case. Moisture trapped in the case can adversely affect components. If moisture does enter the carrying case, leave it open and allow it to dry thoroughly before storing any components.

12. To prevent vandalism or theft, do not leave the removable Topcon components on the machine during off hours. Remove the components after work and store in carrying case.



---

## SMOOTHTRAC™

### Sonic Averaging System (SAS)

## Installation

1. During installation, in order to accurately align the beam assembly onto the pivot post, use the center portion of the beam or equivalent weld fixture.
2. Both attachment posts must be mounted (welded) perpendicular to upper surface of the tow arm, and parallel to each other.
3. Prior to installation of the L arms, align locking collar on the end gate post with the stop collar on the tow arm pivot post.
4. Orientation of the L arms are dependent upon the height alignment of both collars. The L arms can be installed with 16" post in either the upright or downward pointing direction in order to raise or lower the beam and place the tracker within the required sensing range.
5. Loosely coil the cable about the beam sections and use the cable clamps to prevent sagging loops that might create a safety hazard.
6. After initial installation, assure a good path to ground by partially tightening handles and lock bolts, and then moving all folding joints in and out. This should remove all paint which could prevent good grounding.

**NOTE: A BAD GROUND WILL CAUSE UNSTABLE LIGHTS ON TRACKERS.**

**SMOOTHTRAC™**  
Sonic Averaging System (SAS)

**Tow Arm Mount**

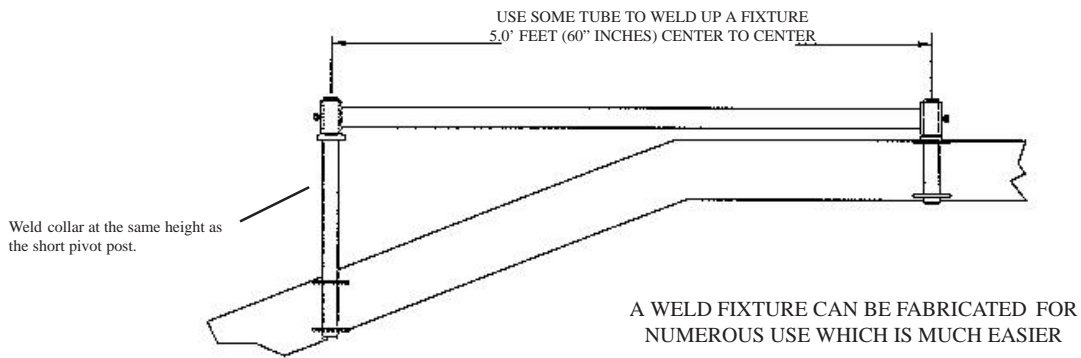
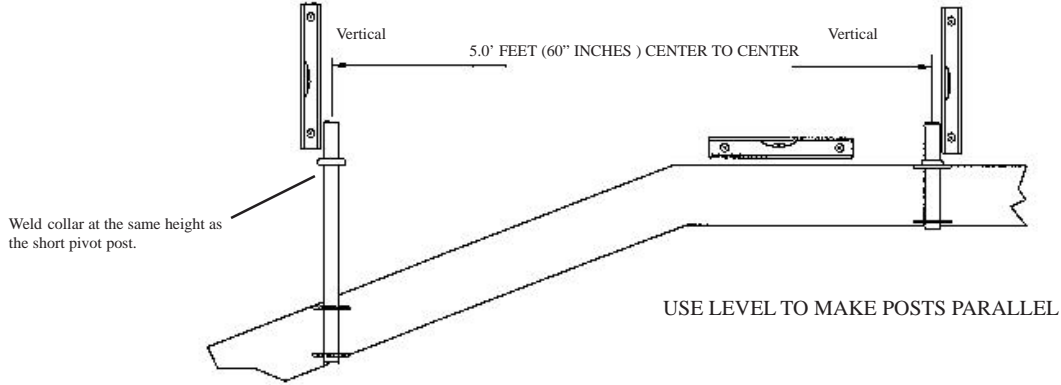

*THE WELDING OF THE TWO PIVOT POSTS ARE 5 FEET (60") APART BECAUSE THE PIVOT BLOCKS ON THE BEAM ARE AT 5 FEET APART. WITH THE "L-ARMS" THIS CREATES A PARALLELOGRAM. THUS ALLOWING THE BEAM TO BE EXTENDED OR RETRACTED AWAY FROM THE MACHINE SMOOTHLY AND EVENLY. IF THE "L-ARMS FIGHT EACH OTHER, THE POSTS ARE NOT THE SAME AS THE BEAM.*

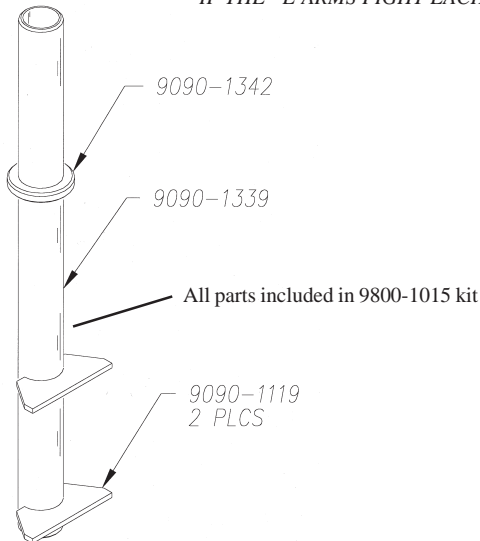

**NOTES:**

1. After welding tow arm pivot post perpendicular to the tow arm, install weld fixture / center portion of beam onto post and clamp in place.
2. Install long pivot post (9090-1339) into fixture / center portion of beam, butt collar (9090-1342) up against clamping block of the fixture, and tighten handle.
3. Place weld gussets (9090-1119) onto post and tack to tow arm. Check alignment prior to final welding.

**SMOOTHTRAC™**  
Sonic Averaging System (SAS)

**Tow Arm Types**

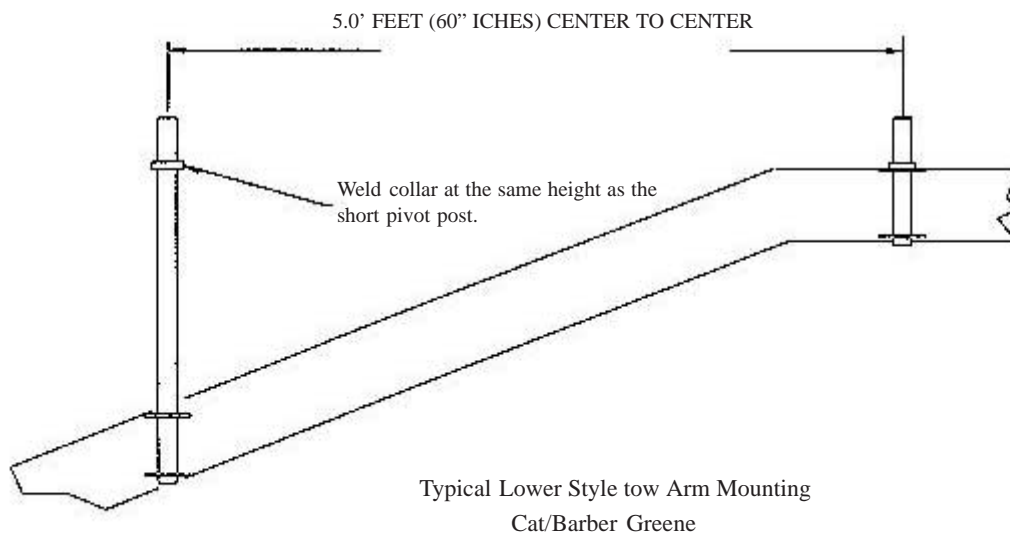
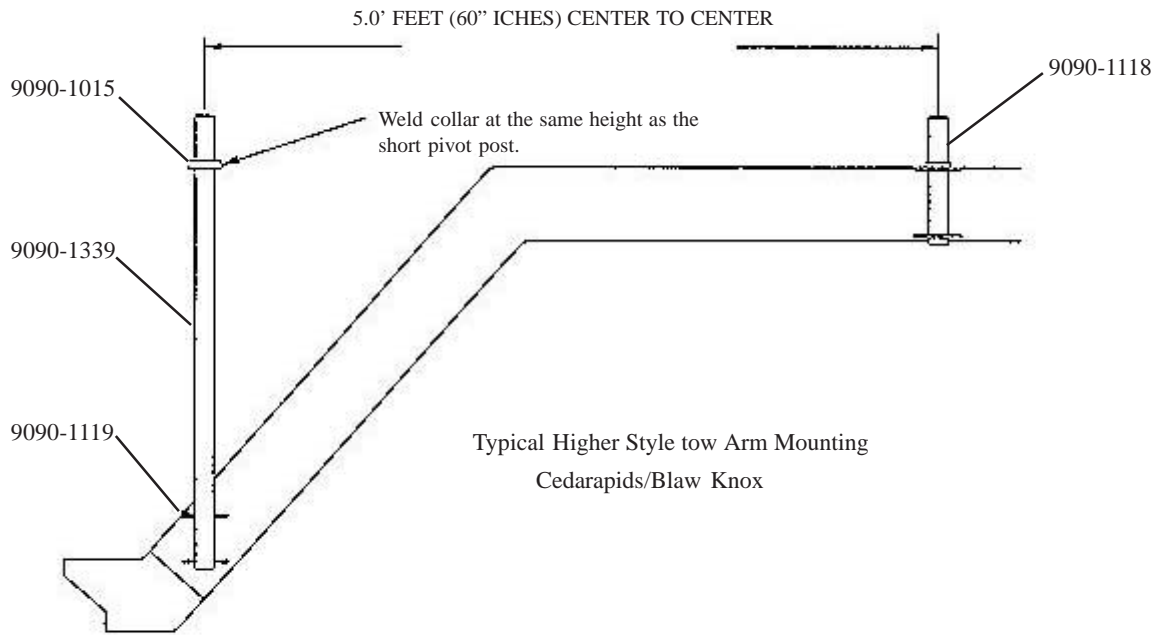

**SMOOTHTRAC™**  
Sonic Averaging System (SAS)

**CR300 Series Pavers**

NOTES:

1. REST SCREED ON 1.50" HIGH BLOCK (2 X 4)
2. CENTER TOWPOINTS
3. NULL SCREED WITH HAND CRANKS
4. REMOVE EXISTING HARDWARE FROM SPACER BLOCK. INSTALL ITEM 2 WITH EXISTING LOCK WASHER AND ITEM 10 CAPSCREW.
5. MOUNT ITEM 5 AS SHOWN
6. TEMPORARILY INSTALL ITEMS 1, 3 AND 4
7. USING ASSEMBLED TOPCON BEAM FROM KIT, LOCATE AND TIGHTEN FRONT SUPPORT.

ITEM	QTY	PART NO./PATTERN NO	DESCRIPTION	REQ.
1		09704-906-42	FRONT PLATE SAS	2
2		09704-906-50	BACK MOUNT	2
3		09704-906-44	CLAMP	6
4		09704-906-46	FRONT SUPPORT	2
5		09704-906-47	BACK SUPPORT	2
6		07383-070	CAPSCREW 1/2 NC X 1-1/2	12
7		07383-068	CAPSCREW 1/2 NC X 1	16
8		07014-020	1/2 WASHER	16
9		07014-005	LOCK WASHER 1/2	28
10		07383-120	CAPSCREW 3/4 NC X 2-1/2	4

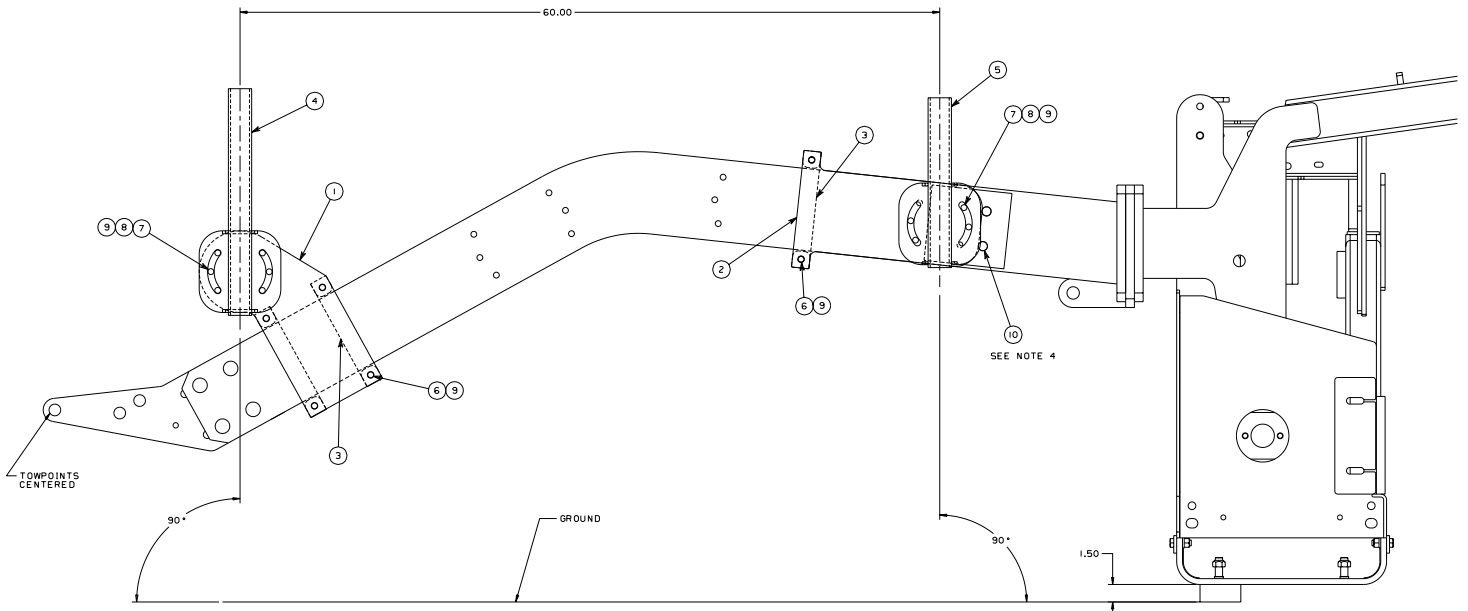

LEFT HAND SHOWN RIGHT HAND OPPOSITE AND EQUAL

**SMOOTHTRAC™**  
Sonic Averaging System (SAS)

**CR400/CR500 Series Pavers**

NOTES:

1. REST SCREED ON 1.50" HIGH BLOCK.
2. CENTER TOWPOINTS
3. NULL SCREED WITH HAND CRANKS.
4. TEMPORARILY INSTALL ITEMS 1, 2, 3, 4 & 5 AS SHOWN.
5. USE TOPCON BEAM FROM "SAS" KIT FOR FINAL LOCATION.

ITEM	QTY	PART NO./PATTERN NO	DESCRIPTION	REQ.
1		09704-906-42	FRONT PLATE SAS	2
2		09704-906-43	BACK PLATE SAS	2
3		09704-906-44	CLAMP	8
4		09704-906-46	FRONT SUPPORT	2
5		09704-906-47	BACK SUPPORT	2
6		07383-070	CAPSCREW 1/2 NC X 1-1/2	16
7		07383-068	CAPSCREW 1/2 NC X 1	16
8		07014-020	1/2 WASHER	16
9		07014-005	1/2 LOCK WASHER	32

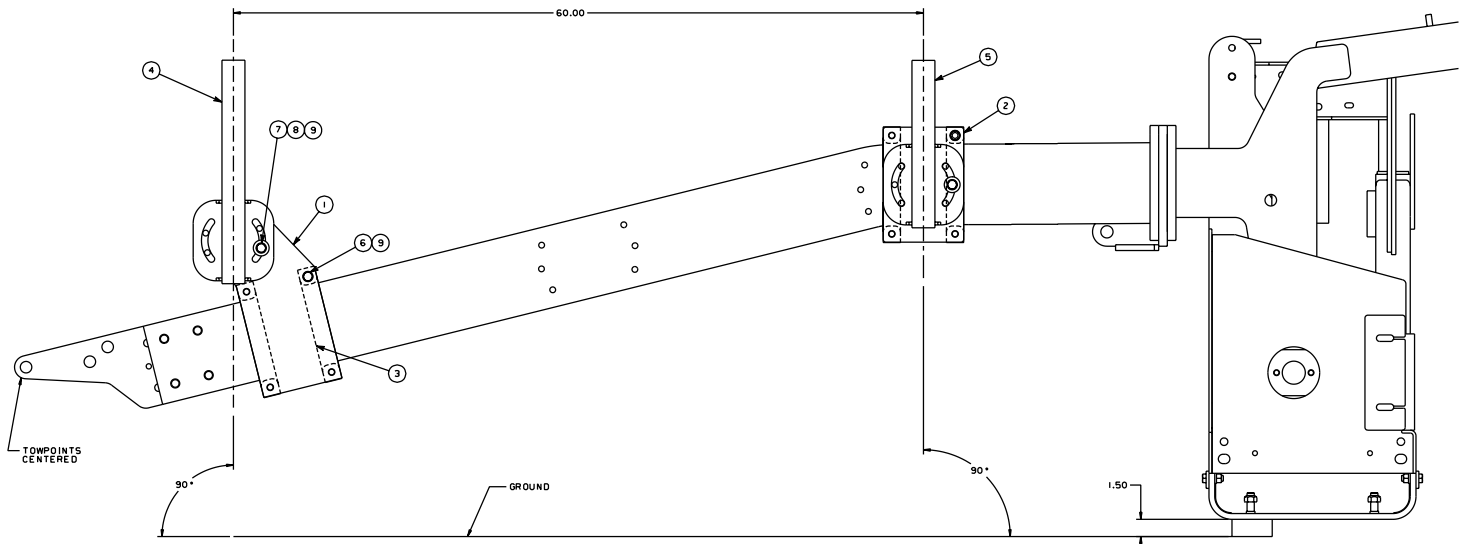

LEFT HAND SHOWN RIGHT HAND OPPOSITE AND EQUAL

**SMOOTHTRAC™**  
Sonic Averaging System (SAS)

**Swing Arm Mounting**

A. Either configuration may be typical to lower-height Tow Arm Mounting.

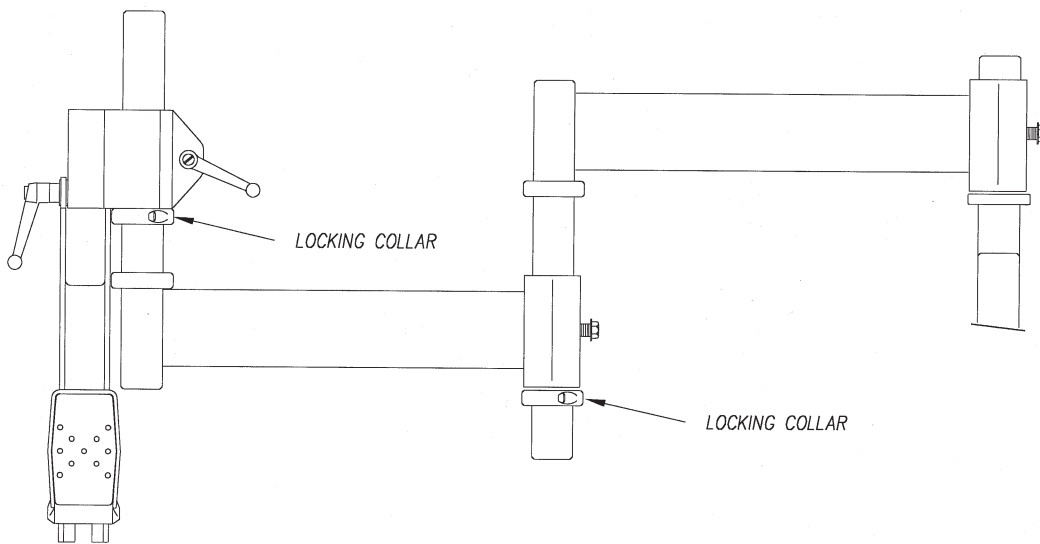
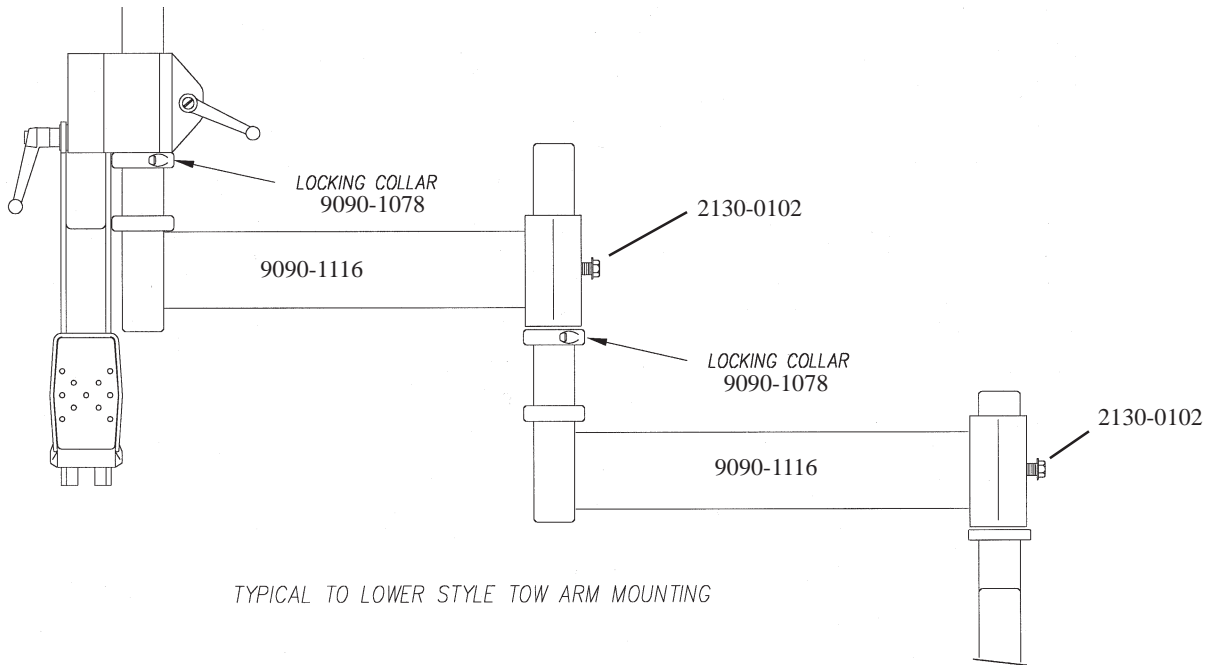

**SMOOTHTRAC™**  
Sonic Averaging System (SAS)

**Beam Assembly**  
Right Side Beam Shown

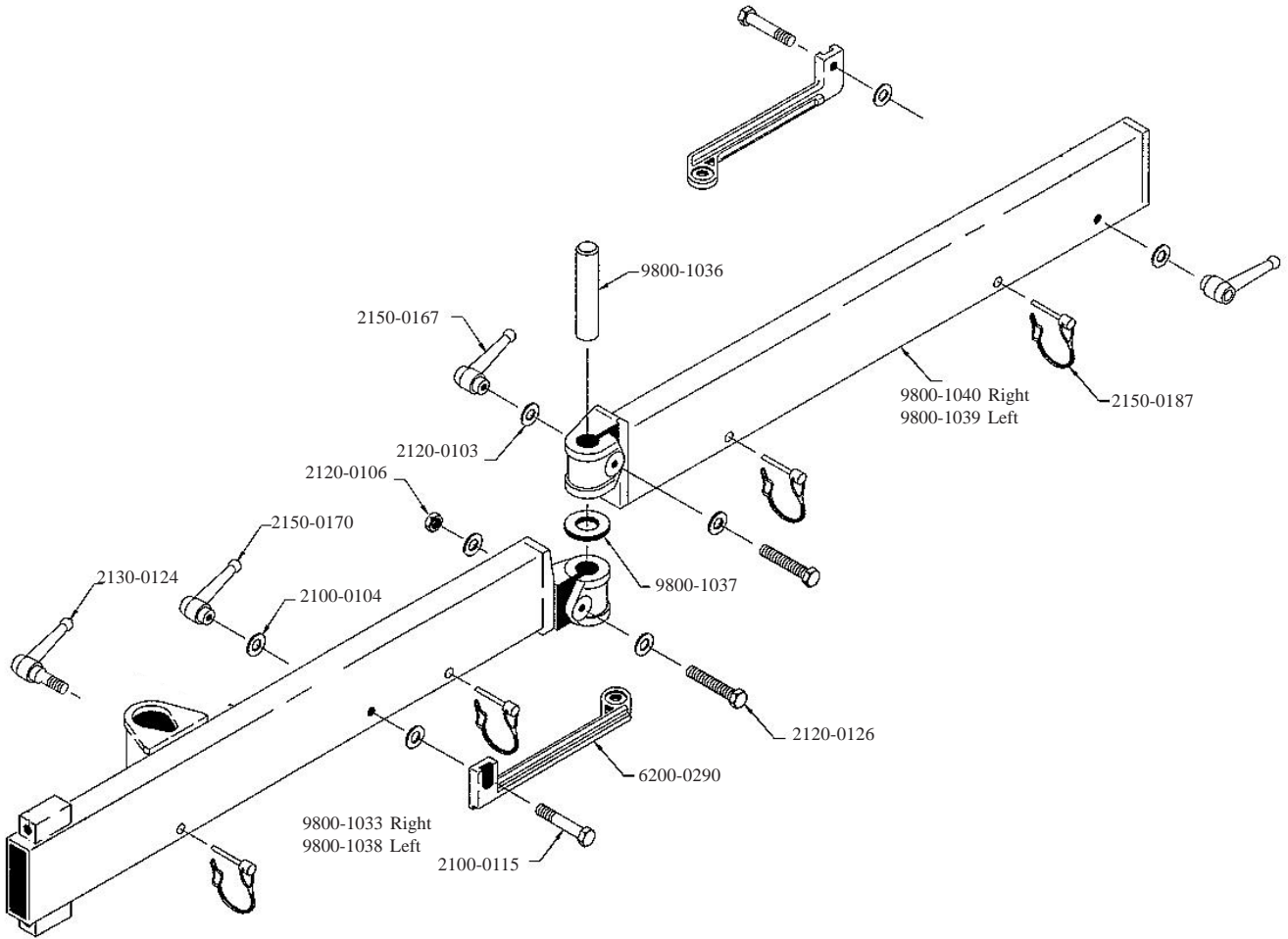

**SMOOTHTRAC™**  
Sonic Averaging System (SAS)

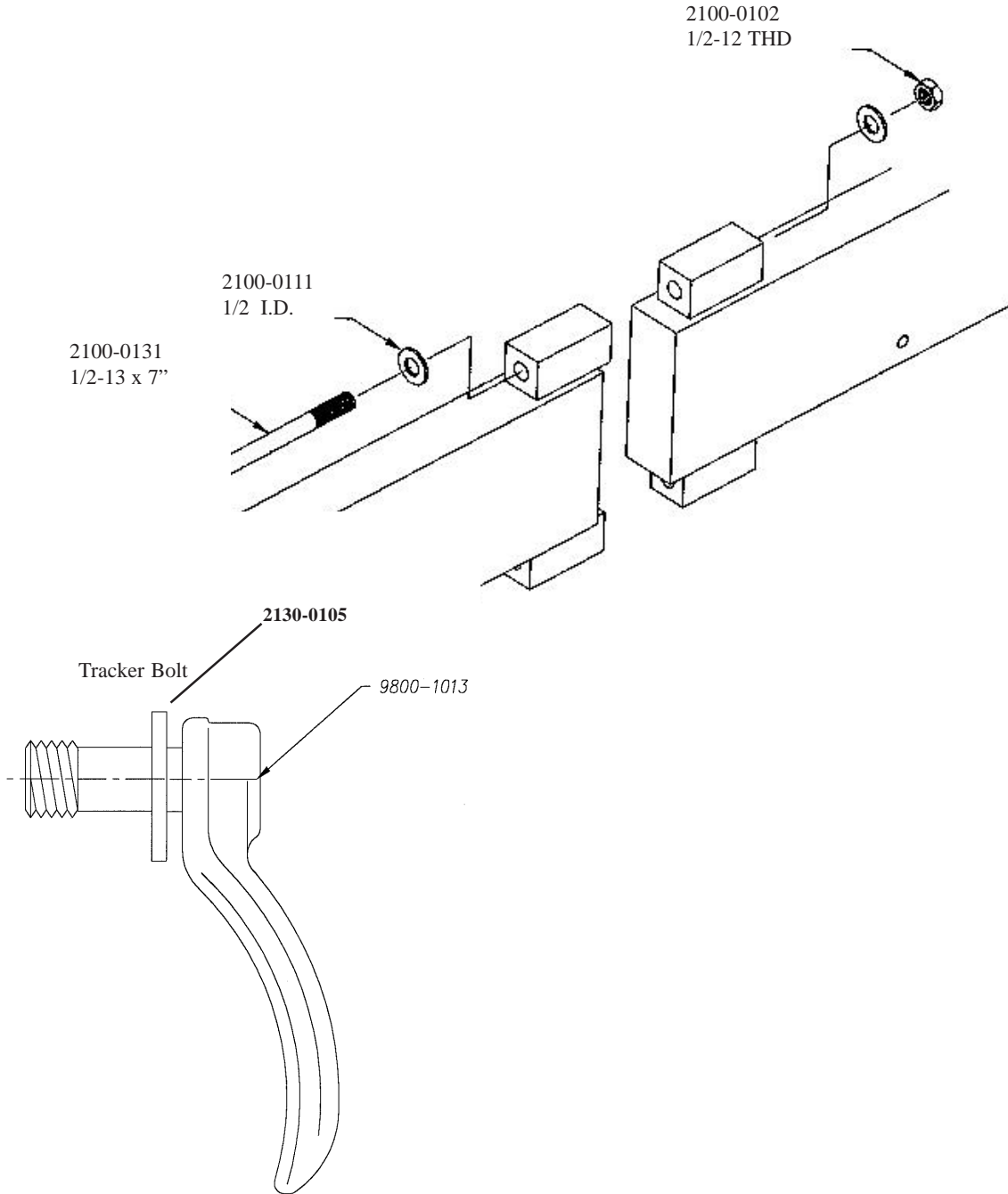

**SMOOTHTRAC™**  
Sonic Averaging System (SAS)

**SAS Cable**

The 9060-5232 SAS Coil cable was designed to give the operator the flexibility of relocating the the Sonic Trackers on the beam by drilling new mounting holes and moving the Tracker hanger.

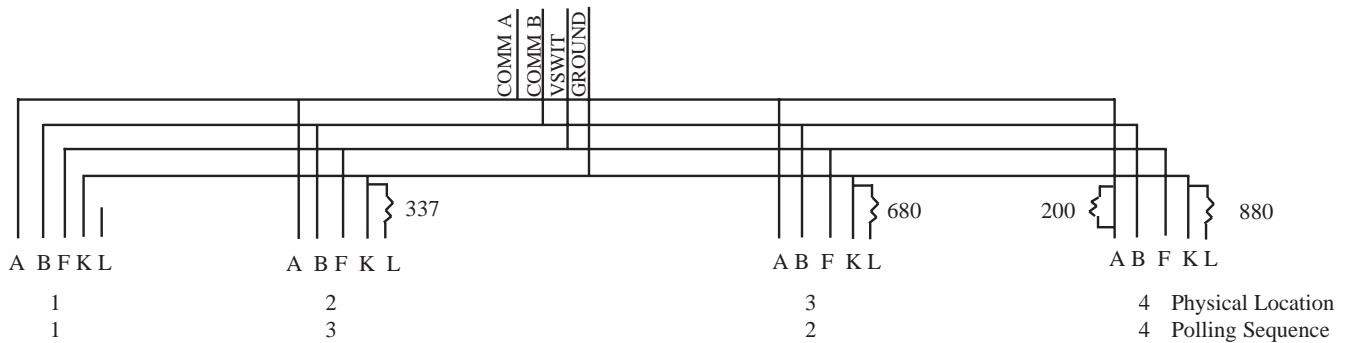
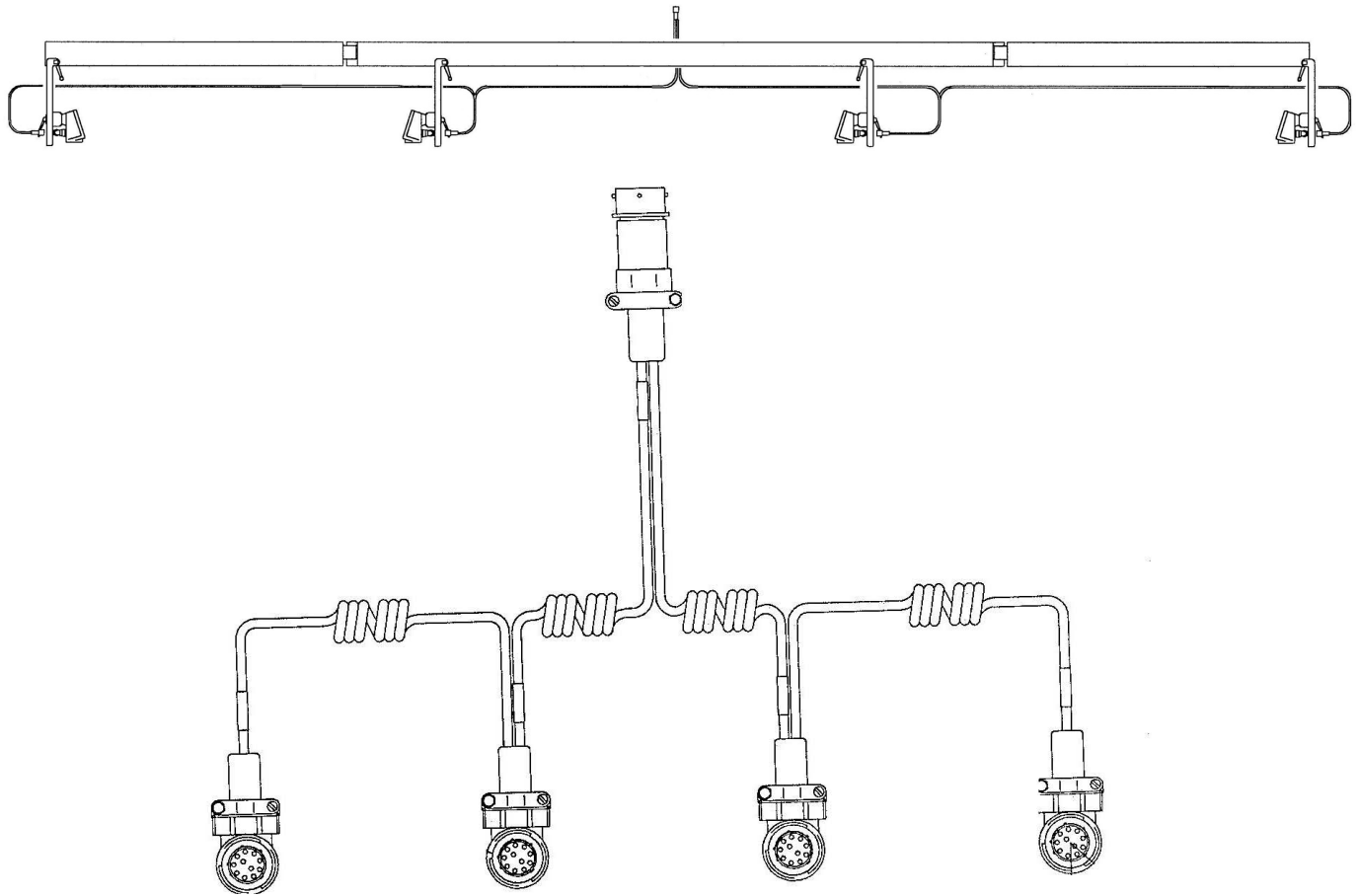

**SMOOTHTRAC™**  
Sonic Averaging System (SAS)

**Assembly Notes**

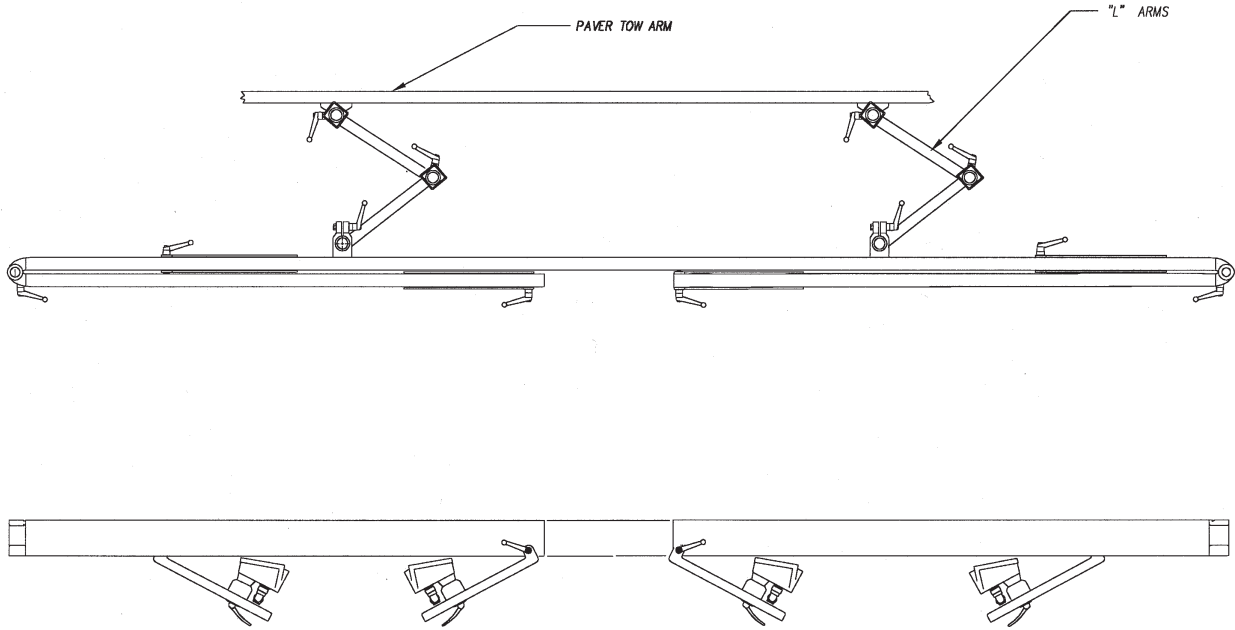

ASSEMBLY FOLDED UNTO ITSELF DURING TRANSPORT ON JOBSITE

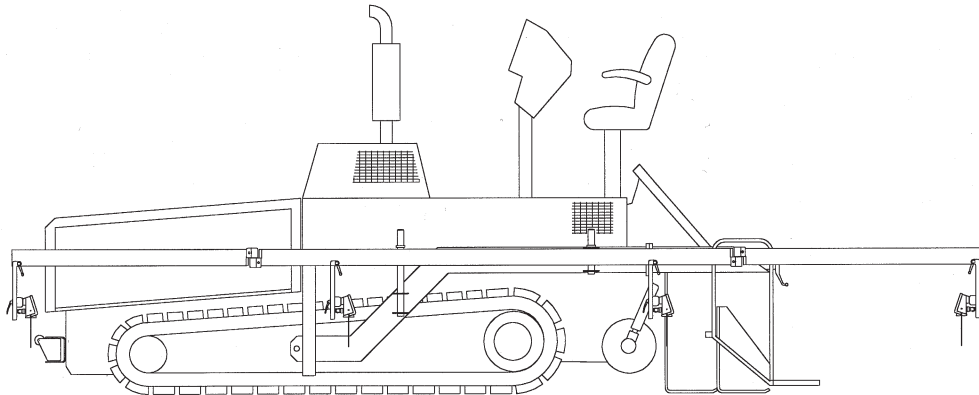

ASSEMBLY EXTENDED FOR USE

**NOTES:**

*During any adjustment, alignment, or orientation of the beam assembly, especially the L arms, all clamp handles must be loosened to allow each section to move freely.*

**Caution:** *Always tighten ALL clamp handles following every adjustment of the beam assembly. This is especially important during transport within the job site.*



---

## SMOOTHTRAC™ Sonic Averaging System (SAS)

### Control Box Setup Instructions for SAS Installation

Refer to the Topcon Paver System Four Operator's Manual (7010-0118) for accessing the System Four Performance settings. *Confirm the Control Box Rev is 3.7 or higher and the Tracker Rev is 2.1 or higher (Both Control Box and Trackers should be labeled with SAS stickers).*

After entering the performance menu follow the steps below:

1. Set SS to equal the number of Trackers being used.  
Range OFF/2-10
2. Lower gains if system response is too quick causing rapid corrections.
3. The frequency setting in the technicians menu may need to be lowered to **3**, if the beam has an oscillation when the machine is sitting still.

**SMOOTHTRAC™**  
Sonic Averaging System (SAS)

**Placement of Sonic Averaging System**

The center connection point of the SAS is the balance point. The position of the balance point to the tow arm is very critical. By moving the balance point, the performance of the system is greatly affected. The balance point of the beam should be located 1/3 to 2/3 the distance from the rear of the screed to the tow point cylinder.

By placing the balance point near the back 1/3 (close to the screed), the systems will have a faster reaction time. By placing the balance point closer to the 2/3 point (near the tow point cylinder), the system will have a slower reaction time. For mainline paving, a slower reaction time is desired.

To determine where to position the SAS on your paver, start by measuring the length of the tow arm. Divide the total length by three. This will give you the placement of the balance point of the SAS on your machine.

**OPERATION**

1. Pave manually until specific mat thickness is established.
2. Turn system on, and set SAS to on-grade (refer to System Four Operator’s Manual for survey information).
3. Pave as normal making thickness adjustments with control box knobs.

**NOTE: BE SURE TEMP BAILS ARE INSTALLED BEFORE OPERATING**

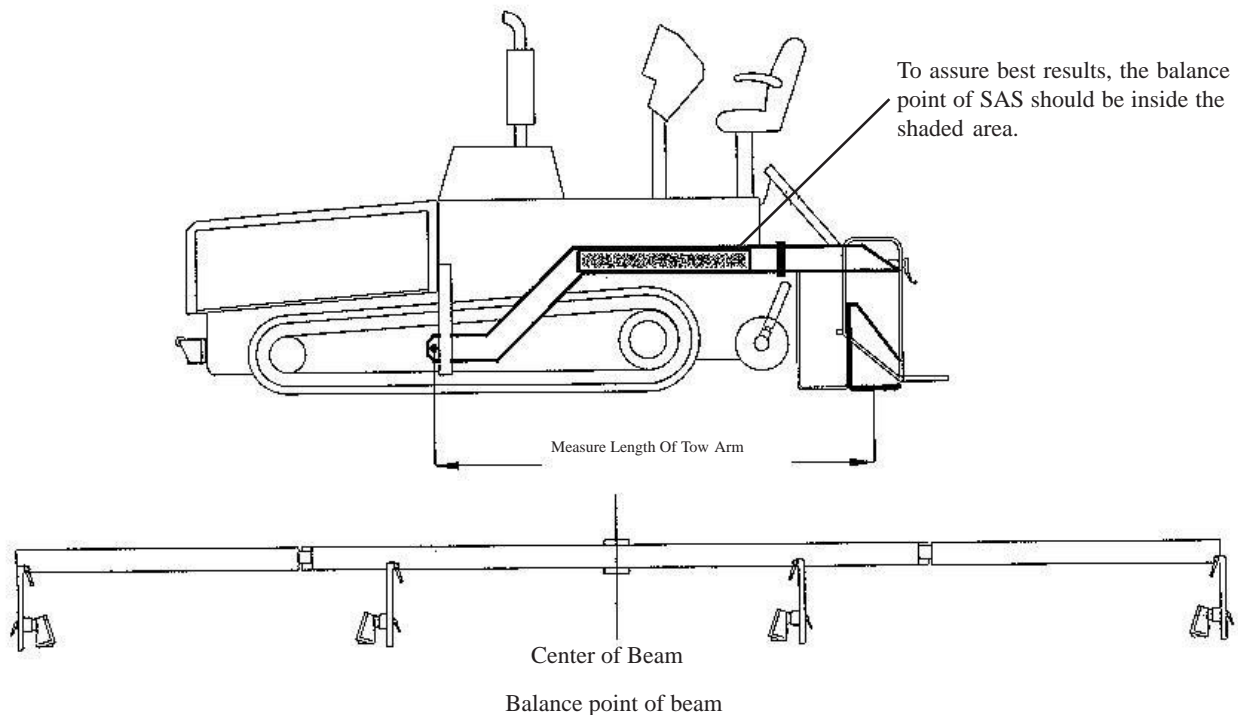

**SMOOTHTRAC™**  
Sonic Averaging System (SAS)

**OPERATION**

The SAS system has been designed to continue to operate even when one of the Trackers fails. When a failure occurs, the control box will flash “ERR” preceded by a number “1-4.” The number represents the Tracker which failed, making trouble- shooting easy and fast. **NOTE:** A number reading of “1” could mean the first or last Tracker has failed depending on which side the beam has been mounted. The SAS cable is labeled with numbers at each connector for easy identification. The system will ignore the Tracker which is causing the error and average the remaining three Trackers. **For best results, replace the faulty Tracker as soon as possible.**

Once one of the Trackers has been eliminated from the averaging, the balance point of the beam will have changed. If the faulty Tracker is not replaced the beam will need to be repositioned to adjust for the new balance point. It is strongly recommended, if the first or last Tracker fails, to replace it with one of the remaining Trackers from the middle of the beam. This will insure that the balance point is not outside of the 1/3 to 2/3 rule.

*If any problems exist during operation or when the machine is stationary refer to page 67 for setup information.*

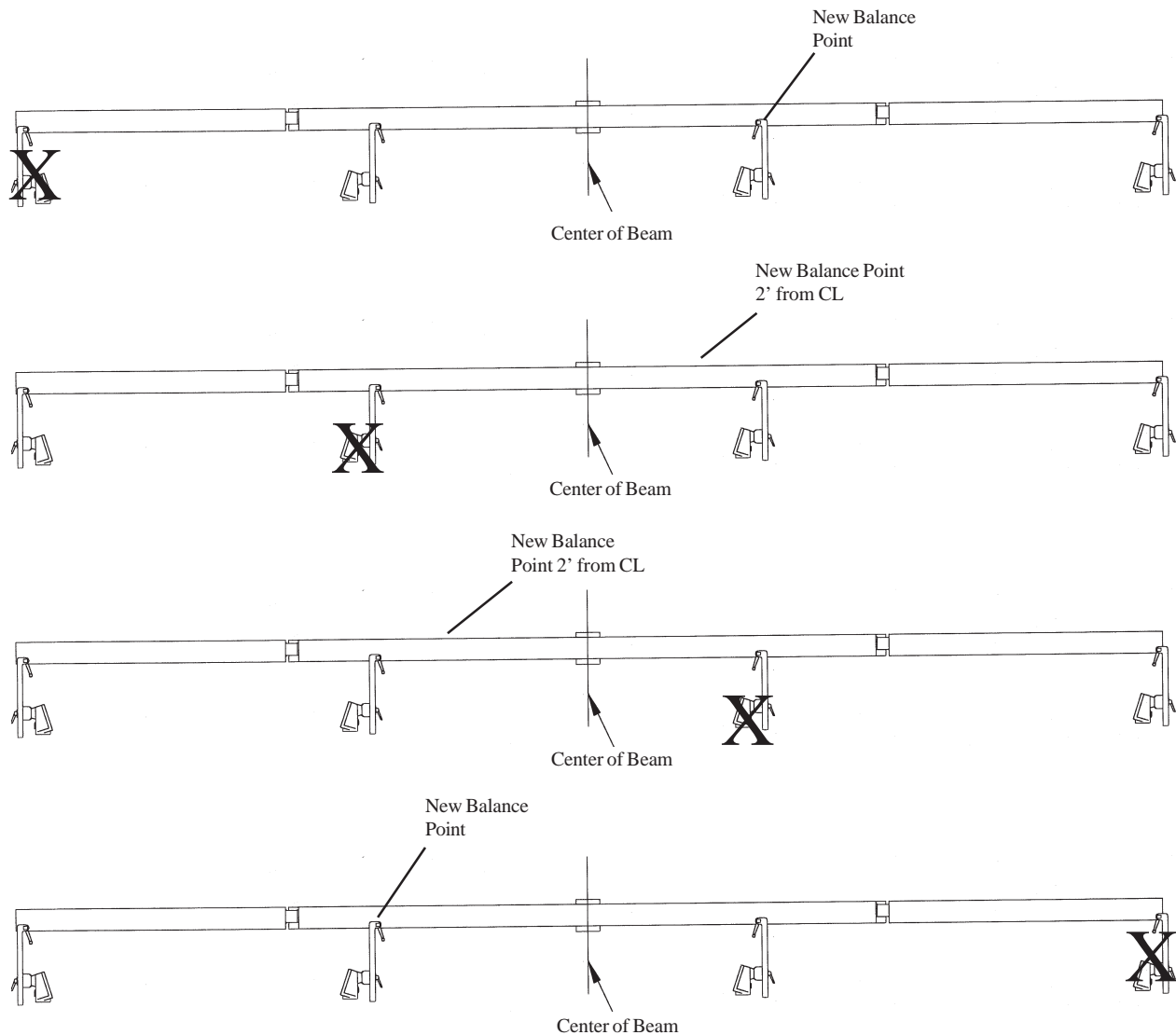

Slope Conversion Table													
Slope	Actual decimal inch per ft.	Approx. fraction inch per ft.	Inch per 10 ft.	Inch per 11 ft.	Inch per 12 ft.	Inch per 13 ft.	Inch per 14 ft.	Inch per 15 ft.	Inch per 16 ft.	Inch per 17 ft.	Inch per 18 ft.	Inch per 19 ft.	Inch per 20 ft.
0.10%	.012	1/64	1/8	1/8	5/32	5/32	5/32	3/16	3/16	7/32	7/32	7/32	1/4
0.13%	.015	1/64	5/32	5/32	3/16	3/16	7/32	7/32	1/4	1/4	9/32	9/32	5/16
0.20%	.024	1/32	1/4	1/4	9/32	5/16	11/32	3/8	3/8	13/32	7/16	15/32	15/32
0.26%	.031	1/32	5/16	11/32	3/8	13/32	7/16	15/32	1/2	17/32	9/16	19/32	5/8
0.30%	.036	3/64	3/8	13/32	7/16	15/32	1/2	17/32	9/16	5/8	21/32	11/16	23/32
0.40%	.048	3/64	1/2	17/32	9/16	5/8	11/16	23/32	25/32	13/16	7/8	29/32	31/32
0.50%	.060	1/16	19/32	21/32	23/32	25/32	27/32	29/32	31/32	1-1/32	1-3/32	1-1/8	1-3/16
0.52%	.062	1/16	5/8	11/16	3/4	13/16	7/8	15/16	1	1-1/16	1-1/8	1-5/16	1-1/4
0.60%	.072	5/64	23/32	25/32	7/8	15/16	1	1-3/32	1-5/32	1-7/32	1-9/32	1-3/8	1-7/16
0.78%	.093	3/32	15/16	1-1/32	1-1/8	1-7/32	1-5/16	1-13/32	1-1/2	1-19/32	1-11/16	1-25/32	1-7/8
0.80%	.096	3/32	31/32	1-1/16	1-5/32	1-1/4	1-11/32	1-7/16	1-17/32	1-5/8	1-23/32	1-13/16	1-29/32
1.0%	.120	1/8	1-3/16	1-5/16	1-7/16	1-9/16	1-11/16	1-13/16	1-29/32	2-1/32	2-5/32	2-9/32	2-13/32
1.5%	.180	3/16	1-13/16	1-21/32	2-5/32	2-11/32	2-17/32	2-11/16	2-7/8	3-1/16	3-1/4	3-13/32	3-19/32
2%	.240	1/4	2-7/16	2-5/8	2-7/8	3-1/8	3-3/8	3-19/32	3-27/32	4-3/32	4-5/16	4-9/16	4-13/16
3%	.360	3/8	3-5/8	3-31/32	4-5/16	4-11/16	5-1/32	5-13/32	5-3/4	6-1/8	6-15/32	6-27/32	6-3/16
4%	.480	15/32	4-13/16	5-9/16	5-3/4	6-1/4	6-23/32	7-3/16	7-11/16	8-5/32	8-5/8	9-1/8	9-19/32
5%	.600	19/32	6	6-19/32	7-3/16	7-13/16	8-13/32	9	9-19/32	10-3/16	10-13/16	11-13/32	12
6%	.720	23/32	7-3/16	7-29/32	8-5/8	9-3/8	10-3/32	10-13/16	11-17/32	12-1/4	12-31/32	13-11/16	14-13/32
7%	.840	27/32	8-13/32	9-1/4	10-3/32	10-29/32	11-3/4	12-19/32	13-7/16	14-9/32	15-1/8	15-21/32	16-13/16
8%	.960	32/32	9-19/32	10-9/16	11-17/32	12-15/32	13-7/16	14-13/32	15-3/8	16-5/16	17-9/32	18-1/4	19-3/16
9%	1.08	1-3/32	10-13/16	11-7/8	12-31/32	14-1/32	15-1/8	16-3/16	17-9/32	18-3/8	19-7/32	20-17/32	21-19/32
10%	1.20	1-3/16	12	13-3/16	14-13/32	15-19/32	16-13/16	18	19-3/16	20-13/32	21-19/32	22-13/16	24
11%	1.32	1-5/16	13-3/16	14-17/32	15-27/32	17-5/32	18-15/32	19-13/16	21-1/8	22-7/16	23-3/4	25-3/32	26-13/32
12%	1.44	1-7/16	14-13/32	15-27/32	17-9/32	18-23/32	20-5/32	21-19/32	23-1/32	24-15/32	25-29/32	27-3/8	28-13/16

All figures in feet are measured horizontally.  
 All figures in inches should be measured vertically and accurately to within 1/32 inch.

Figure 118

## Operation

### Nulling Screed

When we null a screed, we are adjusting the angle-of-attack on the screed to 0 in relation to a given or desired depth. This is traditionally done with the use of boards that equal the desired loose mat depth. (Figure 119) Then a given amount of nose-up attitude is introduced to the screed. The procedure is as follows:

- 1) Obtain boards equal to the thickness of the loose or unrolled mat. The number of boards will depend upon the paving width. Generally use 2 boards at 10 feet wide, 4 boards at 20 feet, etc. The length of each board should be such that the screed bottom is fully supported from front to tail when set on the boards.
- 2) Place the boards under the screed as illustrated. Attention should be placed on the grade conditions where the boards will be placed. If a board is placed on a high point or a depression, a false null setting will occur. Additional boards may be needed if at extended-width paving to provide support for the extension screeds.
- 3) Place the screed lift switch in LOWER/FLOAT mode. The screed will lower down and rest on the boards.
- 4) Turn both manual hand cranks on the screed until the screed face is resting flat on the boards. When the screed is resting flat on the boards, the hand cranks will have a small area of free rotary movement where little resistance is felt. This indicates the null position.
- 5) After the screed has been nulled, introduce a nose-up attitude (initial angle-of-attack) on the screed. The amount of initial angle-of-attack is dependent on material design, temperature of material, head of material, tow point position and type of screed. (Refer to these subjects for more information.)

Generally, the amount of initial angle-of-attack required will be 1 to 2 turns clockwise on the hand cranks. As paving begins, check the depth of the mat being placed and correct for as necessary. As most contractors work with a given number of mix designs, the paver crews quickly learn the exact amount of initial angle-of-attack needed for specific mix designs.

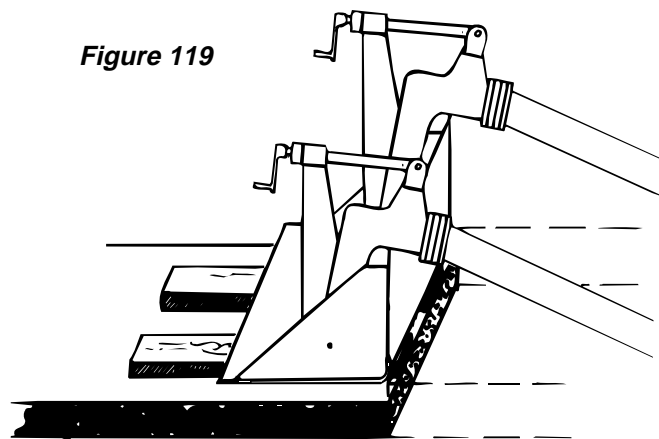

**Screed is Nulled when Laying Flat on Boards**

Joints

There are two types of joints that are constructed in a paving operation: longitudinal and transverse. Proper construction of these joints is important in not only producing a smooth rideable surface but also in how they resist penetration of water, air and other substances that would cause a premature failure of the joint. (Figure 120)

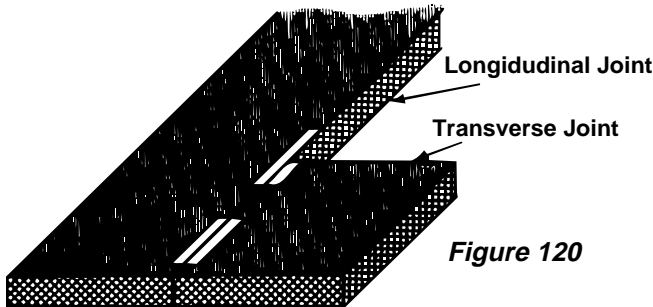

Figure 120

**Transverse Joints**

Transverse joints are created when an existing mat or lane is to be continued. The quality and durability of the joint depends on careful preparation of the existing mat or lane. It is critical that any taper or defective area be removed. **The joint area has to be perfectly flat and parallel with the line of paving!** If not, a depression or bump will be produced.

**Preparation**

As seen in Figure 121, the existing mat is checked with a straightedge and the tapered area removed to produce a joint area that is flat and parallel with the line of paving.

Checking the existing mat with a good straight edge

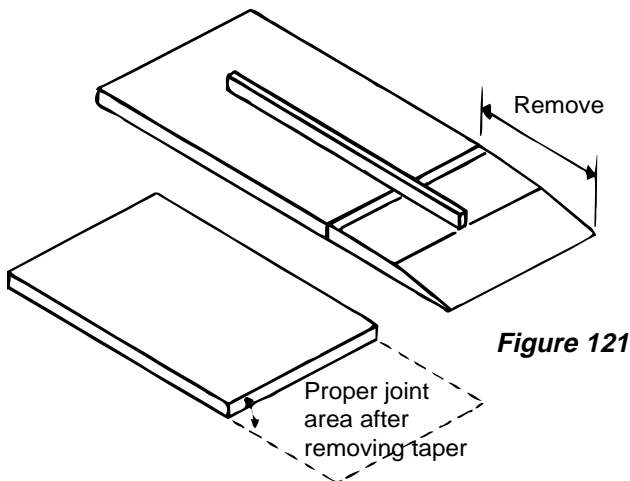

Figure 121

**Construction**

Next place boards or lath on the mat that are as thick as the amount of compaction in the joint area. Remember, compaction rates change due to thickness of material and material design. Once the compaction rate has been determined and the correct thickness of lath has been acquired, place the lath at the edge of the joint to elevate and support the screed at the correct starting level. (Figure 122)

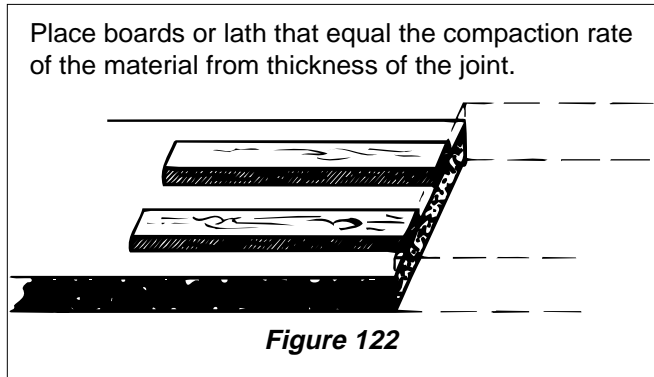

Figure 122

The screed should be preheated to the temperature of the material being used. A cold screed will not only tear the surface of the mat being placed but will also have a tendency to come off the joint low, creating a depression in the mat. Do not over-heat the screed bottom, as this will damage or warp the screed bottom. (Refer to Screed Heaters.)

Back the paver up over the joint and align the screed so the face of the screed is square with the edge of the joint. Lower the screed onto the boards and null the screed. ( Refer to Nulling Screed.)

Once the screed has been nulled and the initial angle-of-attack has been introduced, the auger chamber should be filled to the level of the auger shaft. **Do not** over fill the auger chamber, as this is the most common cause of creating a bump when pulling off a joint. If needed, the corner areas on the ends of the screed should be hand-filled to prevent force-feeding an excessively high head of material in the center areas of the screed. Refer to Head of Material. (Figure 123)

Joints

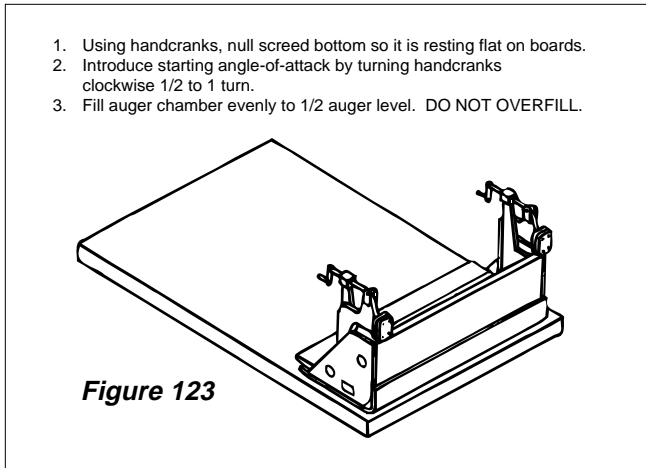

After filling the auger chamber to the correct level, move the paver forward slowly, allowing the screed operator time to check and correct the depth if necessary. The feeder controls should be set to auto, and feed sensors checked and set to maintain the correct head of material. Once the paver has moved away from the joint area, the joint can be checked and prepared for rolling. The excess or overlap material must be removed, as this material cannot be compacted into a cold or existing mat. (Figure 124) Do not shovel this overlap material back onto the fresh mat, as this extra material may not be compacted down to the same height as the rest of the joint. This could create a bump.

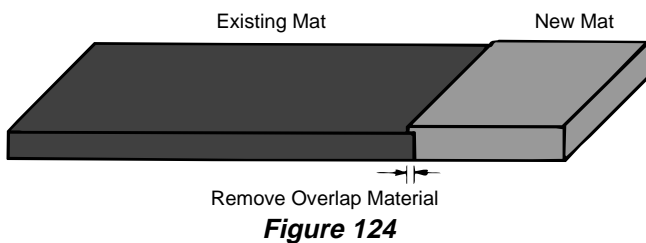

Once the overlap material has been removed, the joint should be checked with a good straight-edge to ensure the thickness of the new mat is correct. If the new mat does not have enough material thickness at the joint when it is rolled, the density in the area where the new mat joins to the old mat will be low. This could cause a premature joint failure. If there is too much material in the joint area a bump will be produced. (Figure 125)

Checking thickness of new mat

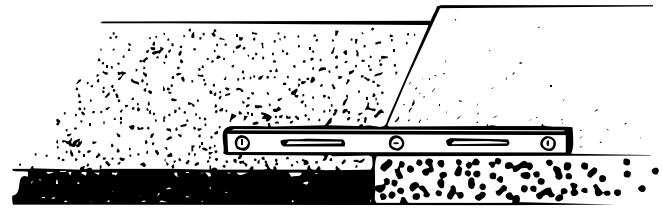

**Figure 125**

After the new mat has been checked for correct material thickness (and corrected if necessary), then the mat can be rolled. After rolling, check the joint with a straight edge to ensure it is at the correct level and no bumps or depressions have occurred.

By taking a little extra time and effort, transverse joints can be constructed to meet specifications for smoothness and durability.

**Longitudinal Joints**

Asphalt longitudinal joints do not have the high maintenance cost and poor ride quality of concrete pavements. Employing proper paving techniques will produce a longitudinal joint that meets specifications for smoothness and will be resistant to penetration of water, air and other substances that would cause a premature failure of the joint.

**Construction**

To get a tight joint between mats, the new mat should not overlap the existing mat more than 1 inch. (Figure 126) Always keep the overlap to the minimum requirement. If a large overlap is required, use a cutoff shoe to block the mix from building up under the screed in the overlap area. If excessive mix is allowed to build up under the screed in the overlap area it will eventually support the screed and actually cause the screed to rise. This leads to control and texture problems, as a nose-down attitude will have to be introduced to prevent the screed from climbing.

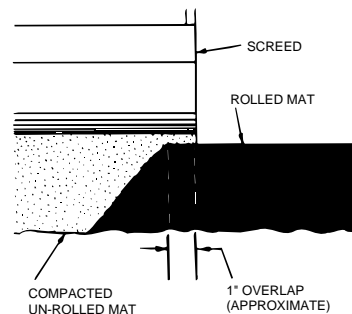

**Figure 126**

## Joints and Segregation

When matching one mat to another, use a 6 inch or a 1 foot screed extension on the joint matching side. This provides a small separate screed bottom to absorb the extra wear that occurs when a slight overlap is required. Extra wear would otherwise take place on one tip of the main screed bottom and destroy its uniformity.

The screed should never ride on the existing mat. For proper joint sealing and density, it is critical that material depth at the joint be sufficient to allow for compaction by the roller. If material thickness at the joint is insufficient to allow for compaction rates, the joint will not resist penetration of water, air and other substances that would cause premature failure of the joint.

### Using Automatics

Automatic screed controls should always be used when matching longitudinal joints. They will produce a very accurate match if set up properly. Traditionally a grade sensor with a joint matcher shoe is used to match joints. This combination is very responsive to the elevation or profile of the existing mat, and the new mat produced will follow the profile of the existing mat. (Figure 127) However, problems of rideability occur when the existing mat is not perfectly flat, as any deviations in the existing mat are transmitted into the new mat.

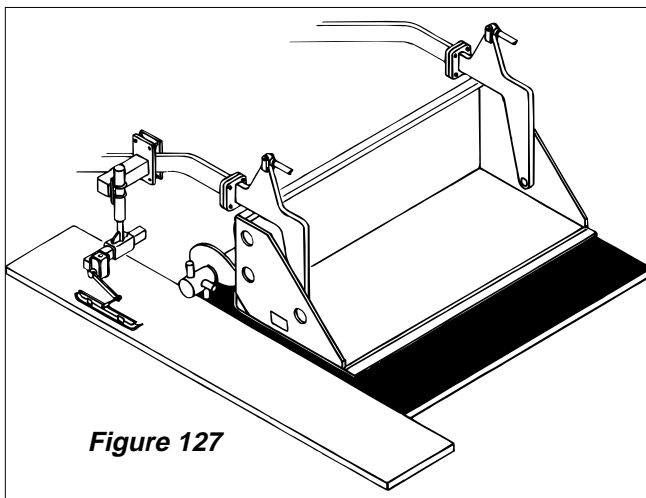
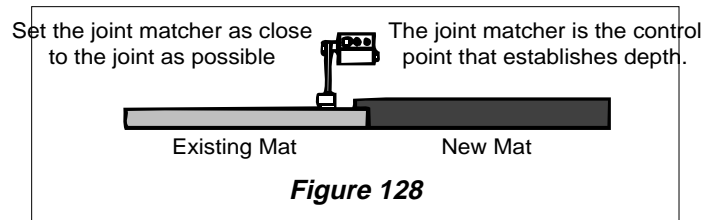

Figure 127

The joint matcher is the control point from which the depth is established. It should be set as close to the joint being matched as possible, taking into account the condition of the joint. If a joint edge has been tapered off due to traffic, it may become necessary to set the joint matcher farther in on the existing mat to find a uniform area from which to reference. (Figure 128)



An alternative to using a joint matcher is to use a ski. This is preferred where the job calls for multiple lift paving. By using a ski on the existing mat the deviations in that mat will not be transmitted to the new mat, thus producing a smooth, uniform mat, though not necessarily matching the joint in a given area. When the final lift is placed, a joint matcher shoe can be used to match the joint exactly.

### Segregation

Segregation in the mat can originate at any point where the materials that make up the mix design are handled or moved. Segregation is primarily related to the gradation of the mix design and the type or shape of the aggregates used in the design. For example, course-graded material designs have fewer fines, and when handled these fines have a tendency to separate from the larger aggregates. Also, a mix design that uses high percentages of smooth-faced aggregates will segregate very easily when handled, as the aggregates have a tendency to roll.

### Segregation (Before The Paver)

When the mat being placed starts showing signs of segregation, the source of the problem has to be found and corrected at the source. (Figure 129) **The paver can not correct for or re-blend materials that are segregated before being placed in the hopper of the paver.**

## Segregation

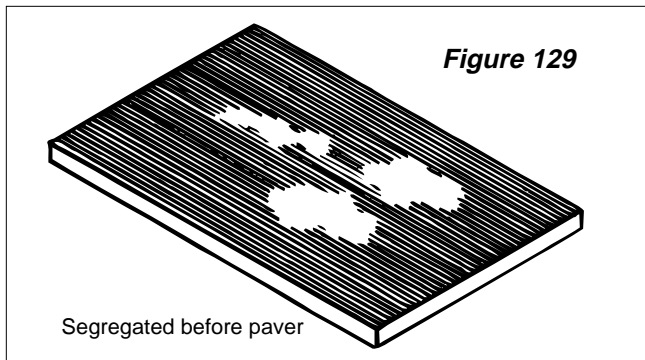

### Segregation (Truck)

If truck loads of material are showing signs of segregation when delivered to the paver, the paver operator should always keep the conveyor deck covered with a minimum of 6 to 10 inches of material. Doing so will prevent the flood of raw rock that is in the rear of the truck from being delivered directly to the auger chamber, and give it a chance to mix with the materials covering the conveyor deck. Often, a segregation problem can be prevented by the method in which each load or batch is dropped into the truck. By placing the first batches or loads in the front and rear of the truck, then filling the center area of the truck, the material will have less of a chance to segregate to the front and rear of the truck.

### Segregation (Stripe)

When a mat is showing a segregation stripe about 4 to 6 inches wide down the center of the mat being placed, it is usually caused by missing or damaged material deflector plates that are mounted just ahead of the augers on the bottom of the auger-conveyor drive case. These should be repaired or replaced as necessary. (Refer to Operation and Maintenance Manual.)

Excessively high auger rpm will also have a tendency to segregate the material being placed under the auger-conveyor drive case. The auger rpm should be as low as possible to deliver material across the width of the screed. Auger rpm is affected by the material flow gate setting. (Refer to Head of material.)

Other factors, especially regarding the head of material and grade conditions can give the appearance of a segregating stripe. Refer to these subjects for more information. Adjustment of the main screed crown will not correct for segregation caused by damaged or missing deflector plates or high auger rpm. Refer to Main Screed Crown.)

### Pre-Compaction Stripe

Pre-compaction striping shows up as a 4 to 6 inch wide stripe down the center of the mat, and appears shiny and tight in texture. The stripe is commonly associated with segregation but is actually caused by excessively high auger rpm which pre-compacts the materials being feed under the auger-conveyor drive case. The speed at which an auger turns is affected or changed by the flow gate setting. (Refer to Head of Material.)

---

 Troubleshooting Guide
 

---

**LOOSE STREAK DOWN CENTER OF MAT***Cause:*

- (1) lead crown low
- (2) head of material low
- (3) worn reversing paddles
- (4) mix design
- (5) worn or damaged material deflector plates

*Solution:*

- (1) adjust lead crown
- (2) maintain level at 1/2 auger
- (3) repair or replace
- (4) correct at hot plant
- (5) repair or replace

**SHINY STREAK DOWN CENTER OF MAT***Cause:*

- (1) lead crown high
- (2) pre-compaction
- (3) grade conditions

*Solution:*

- (1) adjust lead crown
- (2) adjust auger speed
- (3) correct the grade

**MAT TEARING***Cause:*

- (1) excessive paver speed
- (2) fixed or hydraulic strike-offs adjusted wrong
- (3) worn or damaged screed bottom
- (4) aggregate larger than mat thickness
- (5) cold material
- (6) waiting too long between truck loads
- (7) cold mix in hopper

*Solution:*

- (1) slow paver speed
- (2) adjust strike-offs
- (3) replace
- (4) check mat thickness
- (5) correct at hot plant
- (6) slow paving speed, increase production, add more trucks
- (7) cycle hoppers

**SURFACE CRACKS AT EDGES OF MAT***Cause:*

- (1) too much lead crown
- (2) mix building up at end of auger and cooling off
- (3) poor mix temperature control

*Solution:*

- (1) adjust screed crown
- (2) adjust auto feed control
- (3) correct at hot plant

**SURFACE CRACKS IN CENTER OF MAT***Cause:*

- (1) not enough lead crown
- (2) head of material fluctuating
- (3) poor mix temperature control

*Solution:*

- (1) adjust lead crown
- (2) adjust auto feed control
- (3) correct at hot plant

**TRANSVERSE CRACKS***Cause:*

- (1) unstable or tender material design
- (2) shifting or unstable underlying mat or grade
- (3) poor bond between the new mat and existing mat
- (4) slippage cracking when rolling
- (5) improper rolling
- (6) poor mix temperature control
- (7) head of material fluctuating
- (8) paving speed too fast

*Solution:*

- (1) check and correct material design
- (2) repair existing mat or grade
- (3) clean and tack coat
- (4) do not use as much tack coat
- (5) instruct roller operator
- (6) correct at hot plant
- (7) adjust auto feed control
- (8) reduce paving speed

---

 Troubleshooting Guide
 

---

**POOR MAT TEXTURE***Cause:*

- (1) tow point too high or low for mat thickness
- (2) changing mix design or temperature
- (3) aggregate larger than mat thickness
- (4) rolling too much
- (5) not using water on roller drums or tires
- (6) screed vibration or amplitude wrong for mix
- (7) fixed or hydraulic strike-offs too high or low

*Solution:*

- (1) adjust tow point
- (2) correct at hot plant
- (3) check mat thickness
- (4) instruct roller operator
- (5) instruct roller operator
- (6) instruct screedman
- (7) adjust strike-offs

**MAT SCUFFING***Cause:*

- (1) full width scuff - cold screed bottom
- (2) outer edges scuffing - cold mix at end of augers
- (3) screed extensions mounted incorrectly

*Solution:*

- (1) heat screed
- (2) add auger extensions
- (3) adjust

**SURFACE TEXTURE FLUCTUATING***Cause:*

- (1) material design changing
- (2) material temperature changing
- (3) poor or changing asphalt quality
- (4) aggregate size too large for mat thickness
- (5) segregation of material
- (6) too much hand raking or walking on loose mat
- (7) worn or damaged screed

*Solution:*

- (1) correct at hot plant
- (2) correct at hot plant
- (3) contact distributor
- (4) increase mat thickness
- (5) find and correct source
- (6) do not walk on mat - use proper paving techniques
- (7) repair or replace

**BLISTERING***Cause:*

- (1) moisture in underlying mat or grade
- (2) moisture in material

*Solution:*

- (1) allow existing mat or grade to dry out
- (2) correct at hot plant

**BROWN STREAKED SURFACE***Cause:*

- (1) poor asphalt cement quality
- (2) gas or oil spilled on material

*Solution:*

- (1) contact distributor
- (2) find cause and correct

**BLEEDING***Cause:*

- (1) excessive moisture in mix
- (2) excessive vibration
- (3) tack coat too heavy
- (4) too much asphalt in mix
- (5) oil or fuel spilled on mat

*Solution:*

- (1) correct at hot plant
- (2) correct at roller
- (3) use less tack coat
- (4) correct at hot plant
- (5) find source and correct

**SETTLING MARKS WHEN STOPPED***Cause:*

- (1) tow point position too high or low for paving depth
- (2) stopping too long
- (3) screed assist not adjusted

*Solution:*

- (1) adjust tow point position
- (2) adjust paving speed to keep paver moving
- (3) adjust screed assist system

---

 Troubleshooting Guide
 

---

**BUMPS***Cause:*

- (1) trucks hitting paver
- (2) fluctuating head of material
- (3) erratic stops and starts
- (4) trucks holding brakes
- (5) roller stopping on hot mat
- (6) worn or damaged screed components
- (7) wrong roll pattern
- (8) roller vibrating in place
- (9) grade and/or slope dead band too tight
- (10) incorrect mounting of ski or grade sensor
- (11) stringline loose
- (12) overcorrecting hand cranks or automation

*Solution:*

- (1) instruct driver
- (2) correct head of material
- (3) instruct operator
- (4) instruct driver
- (5) instruct operator
- (6) repair or replace
- (7) instruct operator
- (8) instruct operator
- (9) adjust dead band
- (10) mount correctly
- (11) correct stringline
- (12) instruct screedman

**RIPPLES***Cause:*

- (1) over-correcting hand cranks or automation
- (2) worn or damaged screed components
- (3) fluctuating head of material
- (4) variation of mix temperature
- (5) excessive rolling speed
- (6) worn augers
- (7) erratic changes in paving speed

*Solution:*

- (1) instruct screedman
- (2) repair or replace
- (3) correct head of material
- (4) correct at plant
- (5) instruct operator
- (6) repair or replace
- (7) instruct operator

**RIPPLES (Continued)***Cause:*

- (8) trucks holding brakes
- (9) rollers on mat too soon
- (10) rollers in bad repair

*Solution:*

- (8) instruct driver
- (9) instruct operator
- (10) repair

**MAT PROFILE INCORRECT***Cause:*

- (1) worn or damaged screed
- (2) grade sensor location incorrect for application
- (3) grade or slope dead band incorrect
- (4) rolling pattern wrong
- (5) uneven tire pressure
- (6) fluctuating head of material
- (7) varying paving speed

*Solution:*

- (1) repair or replace
- (2) move to correct location
- (3) adjust dead band
- (4) instruct operator
- (5) adjust tire pressure
- (6) correct head of material
- (7) maintain same paving speed

**POOR JOINT MATCHING***Cause:*

- (1) overcorrecting hand cranks or automation
- (2) delay in rolling
- (3) fluctuating head of material
- (4) too much overlap
- (5) grade sensor location incorrect
- (6) grade sensor dead band incorrect

*Solution:*

- (1) instruct screedman
- (2) instruct operator
- (3) correct head of material
- (4) instruct operator
- (5) relocate
- (6) adjust dead band

---

 Troubleshooting Guide
 

---

**POOR TRANSVERSE JOINT***Cause:*

- (1) fluctuating head of material
- (2) incorrect joint preparation
- (3) cold screed
- (4) incorrect setup of screed
- (5) poor rolling operation

*Solution:*

- (1) correct head of material
- (2) instruct crew
- (3) heat screed
- (4) instruct screedman
- (5) instruct operator

**SEGREGATION AT BEGINNING OF NEW TRUCK LOAD***Cause:*

- (1) mix segregating while being hauled
- (2) mix segregating in hopper

*Solution:*

- (1) load truck differently
- (2) adjust hopper cycling

**SEGREGATION AT VARYING POINTS IN MAT***Cause:*

- (1) mix segregating at hot plant
- (2) mix design varying

*Solution:*

- (1) correct at hot plant
- (2) correct at hot plant

**SEGREGATION STRIPE IN CENTER OF SCREED***Cause:*

- (1) worn reversing paddles
- (2) cold mix buildup between screed face and auger drive case
- (3) lead crown low
- (4) fixed or hydraulic strike-offs adjusted wrong.

*Solution:*

- (1) repair
- (2) correct head of material
- (3) adjust lead crown up
- (4) adjust strike-offs

**INDENTS OR DEPRESSIONS IN ROLLED SURFACE***Cause:*

- (1) rolling too much
- (2) not finish-rolling properly
- (3) reversing or turning roller too quickly
- (4) stopping roller on hot mat
- (5) roller in bad repair
- (6) rolling mat when mix temperature is too hot
- (7) irregular grade being paved
- (8) unstable or tender mix design

*Solution:*

- (1) instruct operator
- (2) instruct operator
- (3) instruct operator
- (4) instruct operator
- (5) repair
- (6) instruct operator
- (7) correct grade before paving
- (8) correct mix design

**SHOVING OF MAT BY ROLLER***Cause:*

- (1) reversing or turning roller too quickly
- (2) rolling mat when mix temperature is too hot
- (3) excessive high asphalt content
- (4) tire pressure too high
- (5) unstable or tender mix design
- (6) tack coat too heavy
- (7) material temperature too high

*Solution:*

- (1) instruct operator
- (2) instruct operator
- (3) correct at hot plant
- (4) adjust tire pressure
- (5) correct at hot plant
- (6) use less tack coat
- (7) correct at hot plant

## Troubleshooting Guide

### **UNSATISFACTORY COMPACTION**

*Cause:*

- (1) rolling too fast
- (2) rolling too light
- (3) inadequate rolling or not enough rollers
- (4) rolling when material is too cold
- (5) material out of specification
- (6) material temperature too hot or cold

*Solution:*

- (1) instruct operator
- (2) increase ballast, change rollers
- (3) change roll patterns or add rollers
- (4) move roller closer to paver
- (5) correct at hot plant
- (6) correct at hot plant

---

## Paving Terminology

---

**Aggregate:** Various sizes of stones, gravel, pebbles and sand, that comprise the bulk of the material used in asphalt mixes.

**Angle-of-Attack:** The angle at which the screed bottom travels through the asphalt material.

**Asphalt:** The blend of aggregates, fines and asphalt cement.

**Auger:** The spiral components mounted to the rear of the conveyor discharge that spread the asphalt material evenly across the width of the screed.

**Asphalt Cement:** A thick petroleum-based product used to bond the aggregates and fines together.

**Auger Chamber:** The area in which the augers are mounted.

**Automatic Feeder Controls:** The controls mounted to the outboard end of the augers that control the level of material.

**Automatic Grade and Slope Controls:** The electronic grade and/or slope sensory system that controls the angle-of-attack on the screed.

**Averaging:** The ability of the screed to correct for a deviation over a long travel distance.

**Balance:** Refers to the equilibrium of forces and factors that affect the screed's position.

**Compaction:** Process of removing the air voids in the material after placement.

**Conveyor:** The chain and flight bar arrangement on each side of the paver that moves material from the hopper to the augers.

**Conveyor Deck Liners:** The Ni-hard plates or heavy steel plates used to absorb the wear that occurs in the bottom of the conveyor area.

**Cross Beam:** The steel bar connected between the left and right tow arms which is used for mounting the slope sensor.

**Crown:** The ability to change the transverse profile of the mat being placed. Also refers to the transverse profile or the opposite sloping sides of the existing grade.

**Cutoff Shoe:** The detachable plate that fits under the end gates to reduce the paving width of the screed.

**Density:** The degree to which air voids have been removed from a material.

**Depth Crank:** The mechanical adjusting crank located on each side of the screed used for setting or changing the angle-of-attack on the screed.

**Deviation:** A change in elevation or slope in reference to a given point or plane.

**Elevation:** The vertical height measured from a reference point or plane.

**Equilibrium:** Refers to the balance of forces and factors that affect the position or elevation of the screed.

**Fastach Screed:** A standard 8 ft. or 10 ft. fixed width screed.

**Feeders:** The left or right auger-conveyor combination that moves material from the hopper and across the width of the screed.

**Flow Gates:** The vertical adjustable plates located at the rear of the hopper that control the amount or volume of material that passes from the hopper to the auger chamber.

**Frame Raise:** (A) The ability of a rubber-tire paver to raise or lower the position of the frame and augers. (B) The ability of the rear drive tires to move up or down independently of the other.

**Grade:** (A) Refers to the surface over which paving is to be done. (B) Refers to the longitudinal angle of rise or fall of the roadway. (C) Refers to the elevation of the roadway.

**Grade Control:** The electronic system for controlling the longitudinal elevation of the mat from a given reference.

**Grade Sensor:** The electronic sensor unit used for controlling the longitudinal elevation of the mat

**Head of material:** The given volume and level of material in front of and across the width of the screed.

**Hydraulic Strike-off:** The extendable blade or screeding blade mounted to the front of a standard screed.

**Joint:** The area where two mats meet or join.

---

## Paving Terminology

---

**Joint Matcher:** The grade sensor and skate assembly combination used to match the elevation of an existing mat or curb.

**Lift:** Refers to a single layer or mat of a multiple-layered road or refers to the thickness of a specific mat.

**Mat:** Asphalt materials placed by the paver.

**Null or Nulled:** (A) Refers to the screed when the face of the screed bottom is resting flat on a surface with no angle-of-attack. (B) Refers to the automatic screed controls when they are in a position where no electrical signal is being sent or when the indicator lights are out.

**Pre-Leveling:** Correction of existing grade or slope deviations before paving is done.

**Pre-Strike-Off:** The vertical blades mounted to the face screed, used as a material metering device.

**Profile:** Refers to the quick changes that occur in the elevation or slope of a mat with the automation sensors mounted in certain positions.

**Rideability:** Refers to the delayed changes in elevation that occur with the automation sensors mounted in certain positions.

**Ripples:** Frequent or close changes in elevation of the new mat.

**Screed:** The unit that is towed behind the tractor that shapes, smooths and controls the depth of the material being placed.

**Screed Assist:** A hydraulic control system that permits adjusting the weight of a hydraulically extendable screed to match material design and paving width.

**Screed Bottom:** The replaceable plate that contacts, smooths and compacts the material.

**Screed Extensions:** The extra attachment used to extend the paving width of a screed.

**Screed Heaters:** The diesel-fired heaters that pre-heat the screed bottom to the temperature of the material being used.

**Segregation:** The separation of the aggregates from the finer materials.

**Ski:** The floating reference towed beside the screed or tractor that provides a uniform reference for the grade sensor when building rideability.

**Slope:** Refers to the transverse angle of the grade or roadway.

**Slope Control:** The electronic system that controls the transverse angle of the mat being placed in reference to the horizon.

**Slope Sensor:** The electronic unit that detects the transverse angle of the beam it is mounted on.

**Stretch 20 Screed:** A 10 ft. to 20 ft. hydraulically extendable screed.

**String Line:** A fixed reference system that utilizes pins, rods, or bars and a string line and is established along one or both sides of the intended area to be paved.

**Tow Point:** The point from which the screed is attached and towed forward by the tractor.

**Tow Point Cylinder:** The hydraulic cylinders that raise or lower the tow point position.

**Vibrators:** The shaft, eccentric weight and motor combination that produces a vibrating action in the screed when rotated.

---

## Asphalt Paver Component Nomenclature List

---

Developed by the Asphalt Paver Ad Hoc Technical Committee\* of the Compaction & Paving Machinery Technical Committee (CPMTC) of the Construction Industry Manufacturers Association.

**Adjustable Width Strike-Off:** A movable blade on the leading edge of the screed, for varying the mat width.

**Apron:** The area of the hopper in front of the conveyor.

**Asphalt Paver:** A self-propelled construction machine (either rubber-tired or crawler-mounted) specifically designed to receive, convey, distribute, profile and compact paving material by the free-flowing screed method.

**Auger:** A screw conveyor used to transversely distribute paving material ahead of the screed.

**Automatic Feeder Control:** A self-propelled construction machine (either rubber-tired or crawler-mounted) specifically designed to receive, convey, distribute, profile and compact paving material by the free-flowing screed method.

**Automatic Screed Control:** A system for automatically controlling the mat profile in relation to an external reference. **Grade Control** refers to control of the longitudinal profile. **Slope Control** refers to control of the transverse profile.

**Bevel Edger:** An attachment for putting a sloped surface on the edge of the mat.

**Conveyor:** A device for transferring paving material from the hopper to the auger.

**Conveyor Flow Gate:** A device for regulating the height of paving material being transferred by the conveyor.

**Crown Control:** A device which shapes the screed to form a mat with the desired crown.

**Cut-Off Plate:** An attachment used in conjunction with the screed end plate to reduce the effective screed width.

**Feeder System:** The combined conveyor and auger components which transfer paving material from the hopper and distribute it in front of the screed.

**Hopper:** That section of the paver which receives the paving material from an external source.

**Material Feed Sensor:** A device used to detect a quantity of paving material in front of the screed.

**Material Retaining Plate:** An attachment installed in front of an auger extension to confine the paving material in the auger.

**Mobile Grade Reference:** A towed attachment which provides an independent reference for the automatic grade control.

**Moldboard:** The upper portion of the front of the screed frame that pushes the surplus paving material distributed by the auger.

**Operator:** The person whose primary function is to control the paver's speed and direction.

**Operator Station:** The designated location(s) from which the operator controls the paver's speed and direction.

**Pre-Strike-Off:** An attachment on the front of the screed for metering the paving material.

**Push Roller(s):** The device which contacts the tires of the paving material delivery truck.

**Screed:** The device which is towed behind the tractor to strike off, compact, contour and smooth the paving material. **Fixed Width Screed:** A screed with a constant width that can only be changed by adding or removing extensions. **Variable Width Screed:** A screed with permanently mounted extensions which can be extended or retracted to change the mat width while the paver is in operation.

**Screed Arm:** The attachment by which the screed is connected to and towed by the tractor.

---

Asphalt Paver Component  
Nomenclature List

**Screed End Plate:** A vertically adjustable plate at the outboard end of the screed, to retain the paving material and form the edge of the mat.

**Screed Extension:** A fixed or adjustable attachment to the screed for paving at widths greater than the main screed.

**Screed Heater:** A device to heat the screed plate to prevent adhesion of paving material.

**Screed Lift:** A device used to raise the screed.

**Screed Plate:** That component of the screed that shapes and smooths the top surface of the mat.

**Screed Travel Lock:** A device that secures the screed in the raised position.

**Slope Beam:** The component on which the slope control sensor is mounted.

**Steering Guide:** A sighting device to enable the operator to follow a predetermined course.

**Tamper Bar:** A reciprocating component(s) on the screed, used to provide additional compaction of the paving material.

**Thickness Control:** A device to manually adjust the mat thickness.

**Tow Point:** The point at which the screed arm is attached to the tractor.

**Tractor:** That portion of a paver which provides propulsion and may also receive, convey and distribute paving material.

**Truck Hitch:** A device used to help position a delivery truck in the proper position relative to the paver while it (the truck) unloads paving material into the hopper.

**Tunnel:** The passageway through which paving material moves from the hopper to the auger/screed.

\*The Asphalt Paver Ad Hoc Technical Committee's membership included representatives of the Barber-Greene Co.; Blaw-Knox Construction Equipment Corp.; Caterpillar Inc.; Cedarapids Inc; and Ingersoll-Rand Co.

©1991 Construction Industry Manufacturers Association  
111 East Wisconsin Avenue  
Milwaukee, WI 53202-4879

Rubber-Tire Asphalt Paver  
with Fixed-Width Screed

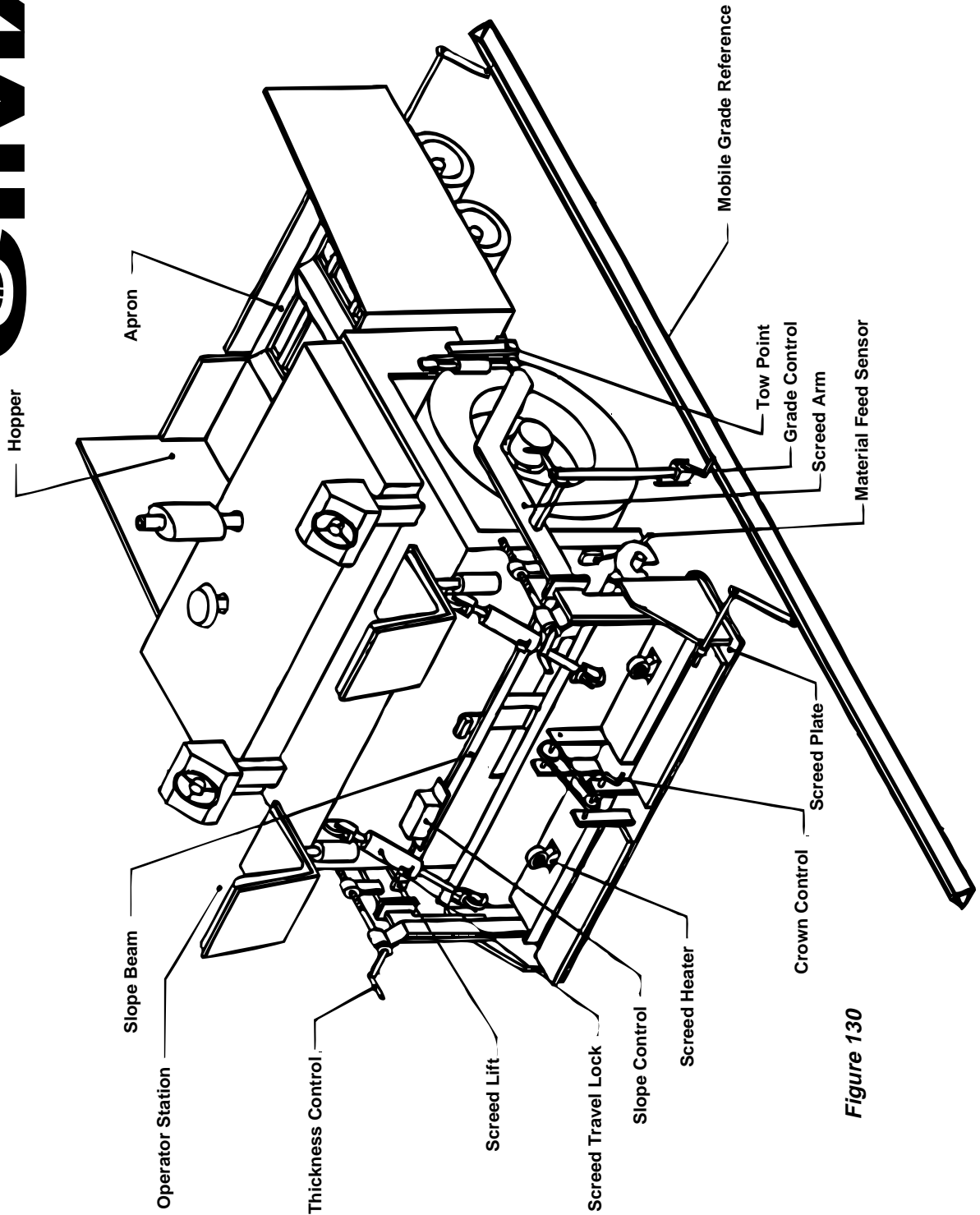
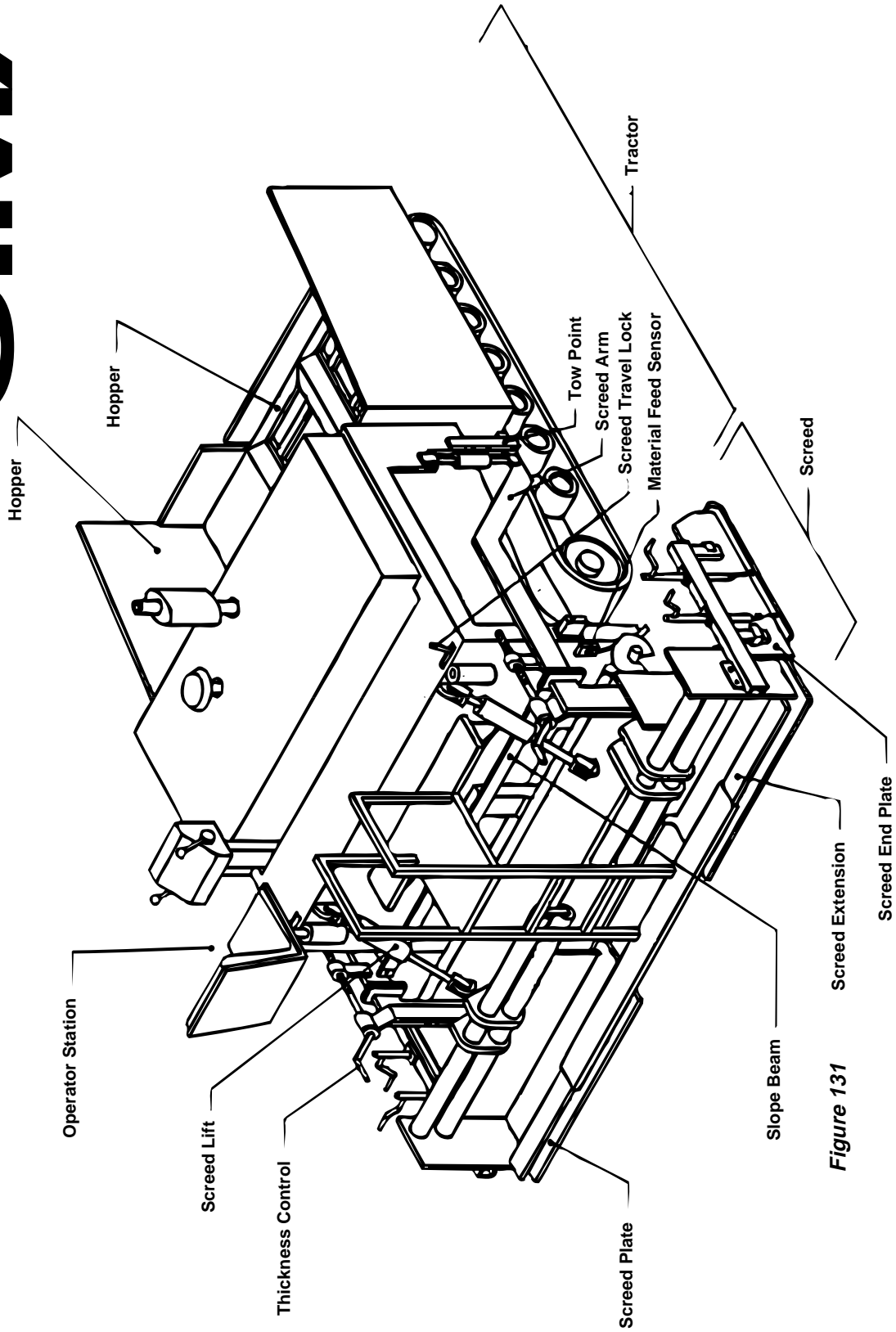

Figure 130

Crawler Asphalt Paver with  
Variable-Width Screed

**CIMA**



**Figure 131**

Rubber-Tired Asphalt Paver with Fixed-Width Screed

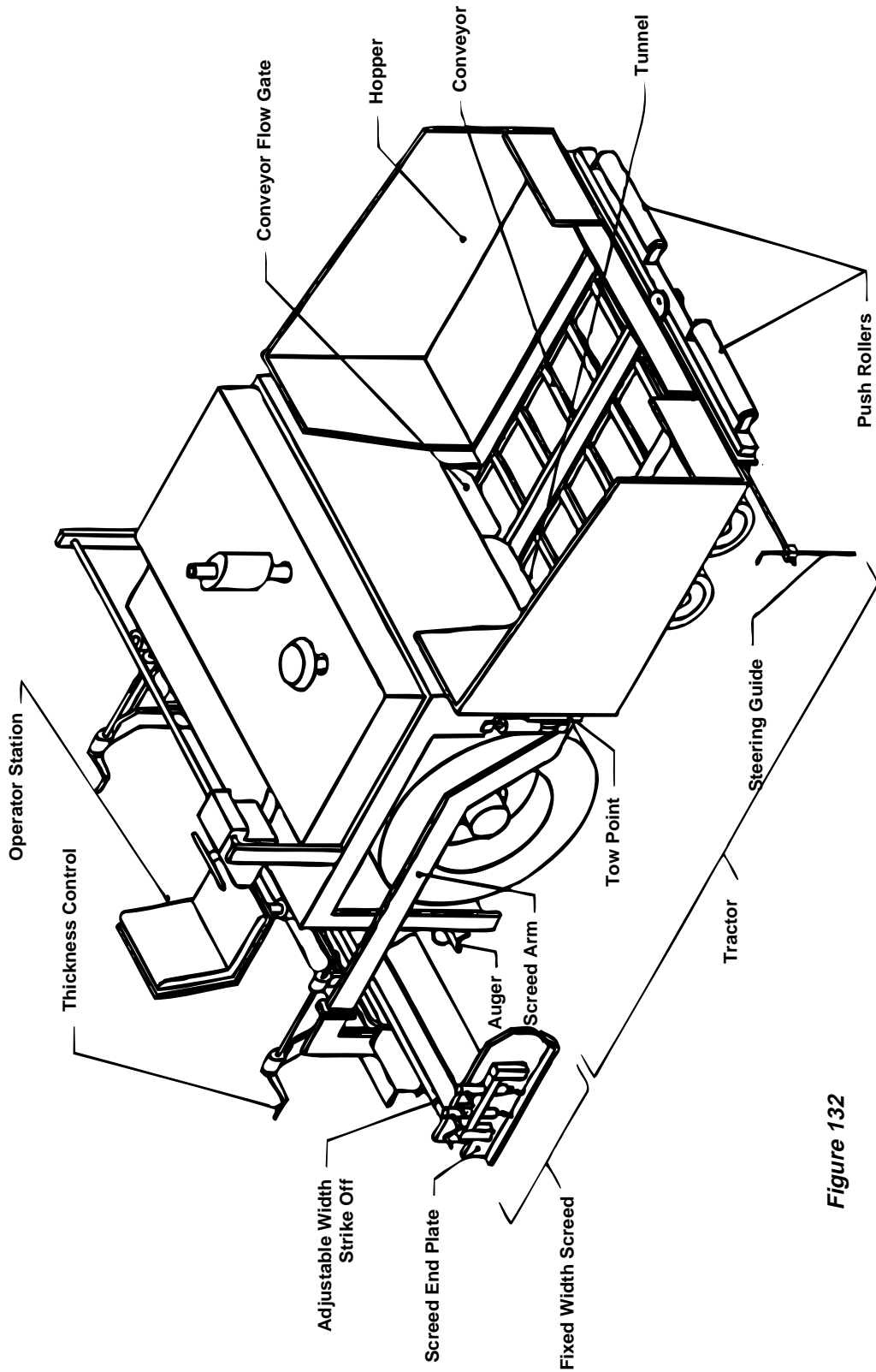

Figure 132

Crawler Asphalt Paver with  
Fixed-Width Screed

**CIMA**

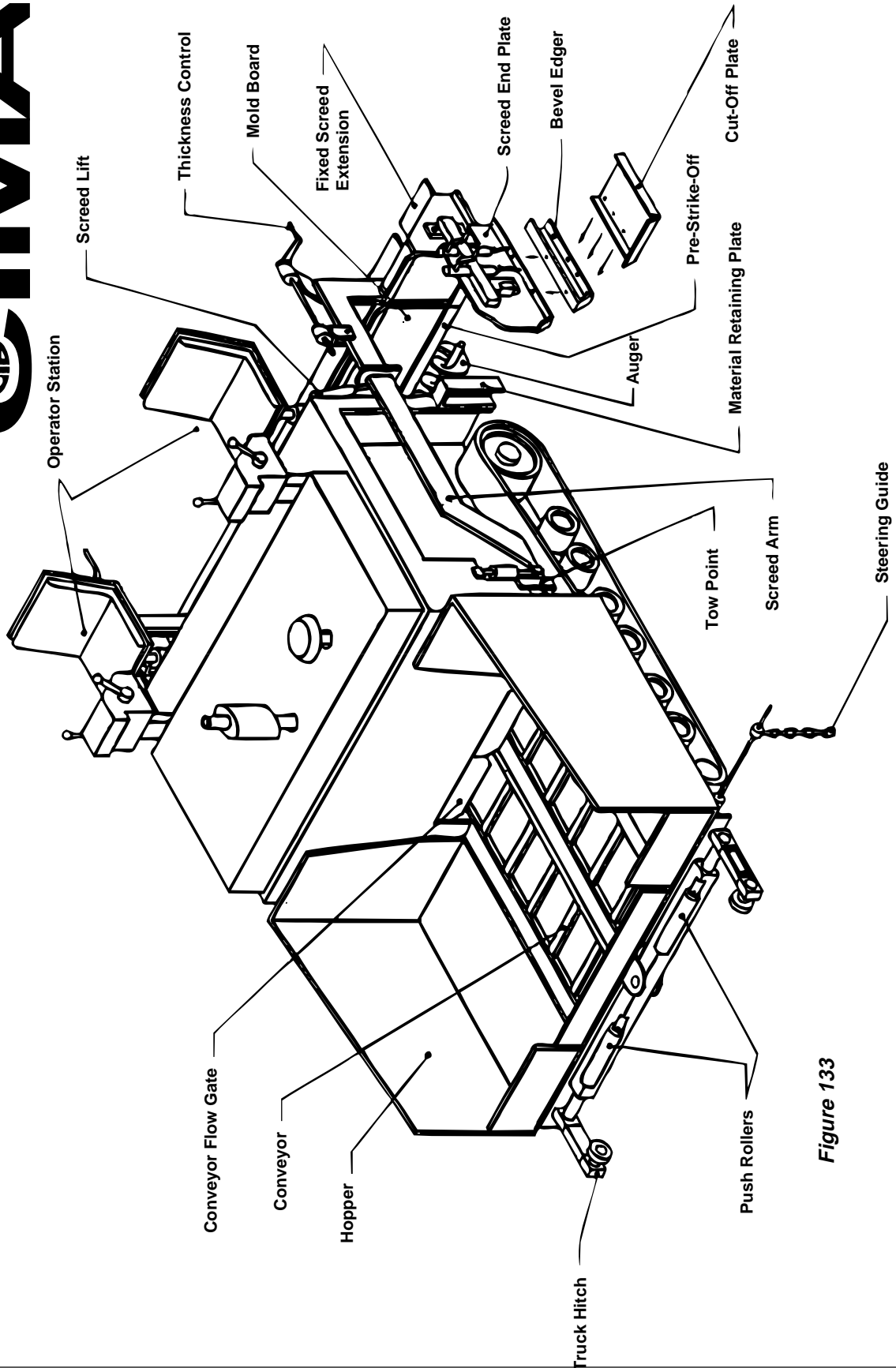

Figure 133

"Compact" Crawler Asphalt Paver

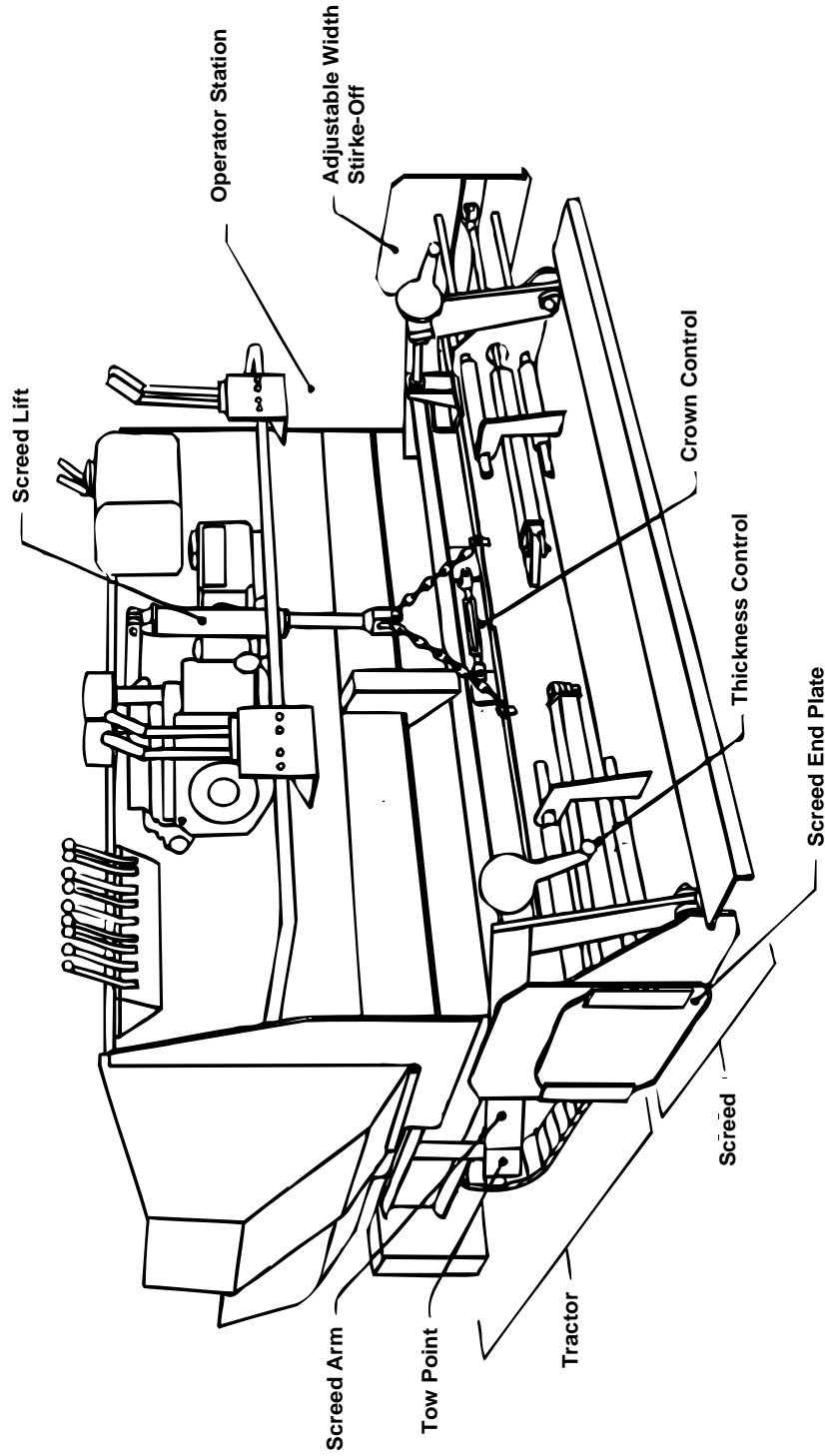

Figure 134

