

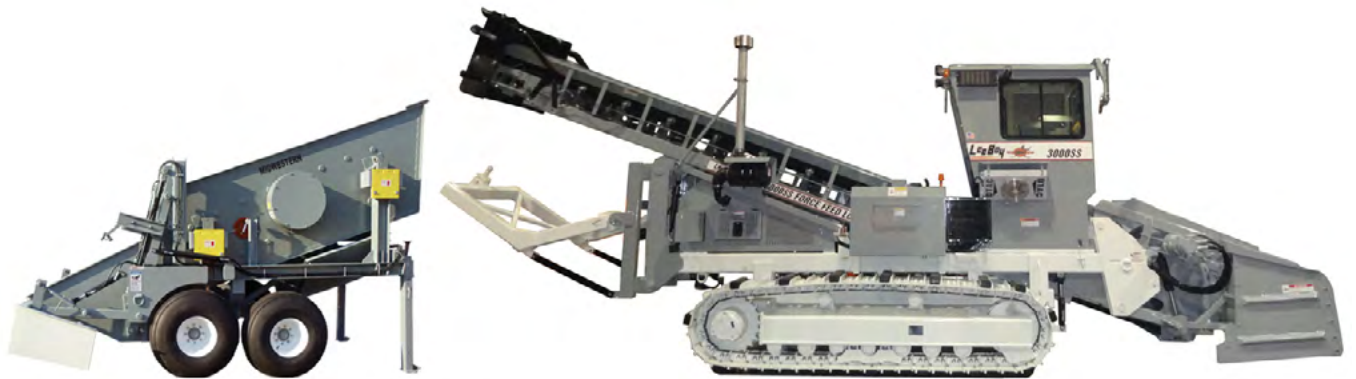

OPERATIONS, SERVICE AND PARTS MANUAL



3000SS Sand Shark with Sand Sifter

Manual No. 1003933-01

Introduction

1

Safety

2

General Information

3

Specifications

4

Component Location

5

Operation

6

Maintenance

7

Troubleshooting

8

Schematics

9

Illustrated Parts List (IPL)

10

DISCLAIMER AND COPYRIGHT

Disclaimer:

All information, illustrations and specifications in this manual are based on the latest information available at the time of publishing. The illustrations used in this manual are intended as representative reference views only. Moreover, because of our continuous product improvement policy, we may modify information, illustrations and/or specifications to explain and/or exemplify a product, service or maintenance improvement. We reserve the right to make any change at any time without notice. VT LeeBoy, Inc., VT LeeBoy, LeeBoy, and Rosco are all the same entity and are used interchangeably.

©2010 VT LeeBoy, Inc.

LeeBoy reserves all copyright and other rights in this manual and the manual's content. No part of this manual may be reproduced or used in any way without the written permission of LeeBoy, except as necessary to operate LeeBoy equipment.

This manual has been most recently updated 02/11 to apply to serial number and above:

65125

PDF file last modified on: 05/10/11



TABLE OF CONTENTS

	Page
Table Of Contents	v
Introduction	1-1
Safety	2-1
Safety Precautions	2-3
Safety Label Locations	2-6
General Information	3-1
Limited Warranty Policy	3-2
Warranty	3-2
Limitations	3-2
Items Not Covered	3-3
Other Limitations	3-3
Contact Information	3-4
Record of Ownership	3-4
Nameplate	3-4
Specifications	4-1
General Information	4-2
Engine	4-2
Hydraulic System	4-2
Torque Hubs and Tracks	4-2
Main Conveyor	4-2
Operator Cab	4-2
Sifter System	4-2
Electrical System	4-3
Specification Charts	4-3
Dimensions	4-6
Torque Specs	4-7

Metric Fasteners	4-7
Inch Fasteners	4-8
Hydraulic Fittings	4-9
Full Torque Nut Coupling Installation	4-9
Component Location	5-1
Control Panels	5-2
Left Operator Control Panel	5-4
Remote Video Monitor	5-6
Switch and Indicator Panel	5-8
Travel Control Panel	5-10
TopCon V Control	5-12
Sifter Remote Control	5-16
Operation	6-1
Introduction	6-2
Inspection Before Initial Start-Up	6-2
Daily Inspection	6-3
Sand Shark Operation	6-3
Start-Up Procedure	6-3
Braking	6-4
Parking Brake	6-4
Selecting High Or Low Speed	6-4
Forward And Reverse	6-4
Increasing Travel Speed	6-5
Feeder Chain	6-5
Discharge Conveyor Belt	6-5
Conveyor Lifting And Lowering	6-5
Stopping The Engine	6-5
Moldboard	6-5
Sifting - Option 1	6-6
Sifting - Option 2	6-6
Transporting	6-7
Sifter Operation	6-7
Feeding And Discharging Connections	6-7
Basic Feed Criteria	6-7
Sifter System	6-8
Sifter Operating	6-9

Maintenance	7-1
Routine Maintenance.	7-3
General Information	7-3
Maintenance Schedule	7-3
10 Hour or Daily Routine Maintenance	7-3
50 Hour Routine Maintenance	7-4
250 Hour or Quarterly Routine Maintenance	7-4
500 Hour or Semi-Annual Routine Maintenance	7-4
Maintenance Check Procedures	7-5
Radiator Check	7-5
Engine Air Filter	7-5
Engine Maintenance	7-6
Fuel System	7-7
Hydraulic System	7-8
Sifter Tire Pressure	7-10
Battery Servicing.	7-10
Machine Lubrication	7-12
Lubrication Points	7-12
Maintenance Adjustments	7-14
Conveyor Belt Centering.	7-14
Chains.	7-15
Moldboard Cutting Edge	7-15
Conveyor Paddle Blade	7-15
Engine Drive Belt	7-16
Charge Filter.	7-16
Hydraulic Cylinder Replacement	7-16
Conveyor Head Pulley Bearing	7-16
Muffler.	7-17
Radiator Hoses And Radiator	7-17
Safety Label Installation	7-18
Track and Sifter	7-18
Change Hub Oil	7-19
Track Adjustment	7-19
Wear Charts	7-19
Lubrication.	7-21
Sifter Bearing Housing Replacement.	7-21

Bearing Replacement Using Existing Housing	7-22
Counterweights	7-23
Screen Panel Tensioning	7-23
Motor External Wiring	7-24
Spreader Bar	7-24
Screen Removal and Installation	7-24
Installation For Decks With Screens	7-27
Installation For Decks Without Screens	7-27
Fines Pan Installation	7-28
Ball Installation.	7-29
Troubleshooting	8-1
Troubleshooting Chart	8-2
Schematics	9-1
Manifold Harness	9-9
LH Joysticks Harness	9-13
RH Joysticks Harness	9-15
Overall Harness 1 of 6	9-17
Overall Harness 2 of 6	9-19
Overall Harness 3 of 6	9-21
Overall Harness 4 of 6	9-23
Overall Harness 5 of 6	9-25
Overall Harness 6 of 6	9-27
Main Hydraulic.	9-29
Sand Sifter (MEV150) Hydraulic	9-31
Illustrated Parts List (IPL)	10-1
Quick Reference Guide - Filters	10-3
Quick Reference Guide - Wire Harnesses	10-3
Quick Reference Misc..	10-3
Multipurpose Moldboard	10-4
Conveyor Paddle Assembly	10-6
Track LH Assembly	10-8
Track RH Assembly	10-10
Track Group - Single Grouser	10-12
Main Frame	10-14
Hydraulic Components	10-16
Tail Pulley Group	10-18

Conveyor Assembly10-20
Head Pulley Assembly10-22
Head Pulley Assembly (continued)10-24
Cab Assembly10-26
Cab Assembly (continued)10-28
Cab Door	10-30
Cab Components10-32
Conveyor Controls10-34
Switch and Indicator Panel	10-36
Right Side Control Panel	10-38
Tier III Engine and Pumps10-40
Tier III Engine Components10-42
Hood and Engine Access Panels10-44
Muffler Assembly10-46
Air Cleaner Assembly10-48
Grille and Radiator Assembly10-50
Hitch Assembly10-52
Sifter Assembly10-54
Alphabetical Parts Index10-58

NOTES



Section 1

INTRODUCTION

Thank you for purchasing the 3000SS Sand Shark with Sand Sifter. We wish you many years of safe and efficient operation of your Sand Shark.

READ THIS MANUAL PRIOR TO OPERATING the unit. This manual is an important part of the Sand Shark and should be kept with the Sand Shark at all times in the dedicated storage container on the 3000SS Sand Shark with Sand Sifter. Even though you may be familiar with similar equipment, you **MUST** read and understand this manual before operating this 3000SS Sand Shark with Sand Sifter. Reading the manual will help you and others avoid injury and help prevent any damage to the 3000SS Sand Shark with Sand Sifter. If this manual becomes lost or damaged, contact your authorized LeeBoy Dealer immediately to order a replacement (see *Contact Information* Section 3).

This manual is intended as a guide for the safe and efficient use of the 3000SS Sand Shark with Sand Sifter. This manual covers the procedures for proper operation and maintenance of the 3000SS Sand Shark with Sand Sifter. This manual contains information that was available at the time of printing and are subject to change without notice.

This manual should be used with all related supplemental books, engine and transmission manuals, and parts books. Related Service Bulletins should be reviewed to provide information regarding some of the recent changes.

If any questions arise concerning this publication or others, contact your local LeeBoy Dealer for the latest available information.

This manual provides information for use by the equipment operator under the following headings:

Safety—See Section 2 for important safety guidelines information.

General Information—See Section 3 for important warranty, contact, and nameplate information.

Specifications—See Section 4 for all major system specifications and typical torque value tables.

Component Location—See Section 5 for general overview of controls and major components.

Operation—See Section 6 for control functionality and normal equipment operation.

Maintenance—See Section 7 for basic preventive maintenance and repair procedures.

Troubleshooting—See Section 8 for problem descriptions and recommended solution tables.

Schematics—See Section 9 for schematic diagrams of electrical wiring.

Illustrated Parts List (IPL)—See Section 10 for illustrations, descriptions and part numbers of available service parts.

NOTES



Section 2 SAFETY

	Page
Safety	2-1
Safety Precautions	2-3
Safety Label Locations	2-6

This manual provides important information to familiarize you with safe operating and maintenance procedures. Even though you may be familiar with similar equipment, you **MUST** read and understand this manual before operating the 3000SS Sand Shark with Sand Sifter and follow its instructions when operating the machine.

Safety is everyone's business and is our top concern. Knowing the guidelines covered in this section and in Section 1 will help ensure your safety, the safety of those around you and the Sand Shark's proper operation.

LOOK FOR THESE SYMBOLS WHICH POINT OUT ITEMS OF EXTREME IMPORTANCE TO THE SAFETY OF YOU AND YOUR COWORKERS. READ AND UNDERSTAND THOROUGHLY. HEED THE WARNING AND FOLLOW THE INSTRUCTIONS.

Keep safety labels in good condition. If safety labels become missing or damaged, replacement safety labels are available from your LeeBoy Dealer (see also *Safety Label Installation* in Section 7).

DANGER

Indicates a hazardous situation which, if not avoided, will result in death or serious injury.

WARNING

Indicates a hazardous situation which, if not avoided, could result in death or serious injury.

CAUTION

Indicates a hazardous situation which, if not avoided, could result in minor or moderate injury.

NOTICE

Indicates a situation which can cause damage to the equipment, personal property and/or the environment, or cause the LeeBoy Model 3000SS Sand Shark with Sand Sifter to operate improperly.

NOTE: Indicates a procedure, practice, or condition that should be followed in order for the Sand Shark or component to function in the manner intended.

SAFETY PRECAUTIONS

CAUTION

The safety messages that follow have CAUTION level hazards.

Pre-Operation Hazard



Read and understand this Operation Manual before operating or servicing the engine to ensure that safe operating practices and maintenance procedures are followed.

- Never permit anyone to service or operate the 3000SS Sand Shark with Sand Sifter without proper training.
- Safety signs and labels are additional reminders for safe operating and maintenance techniques.
- Contact LeeBoy or an authorized LeeBoy Dealer for additional training.
- Make sure you are aware of all laws and regulations that are in effect where the Sand Shark is operated. Make sure you have all necessary licenses to operate the Sand Shark.

WARNING

The safety messages that follow have WARNING level hazards.

Crush Hazard

Keep bystanders away from work area before and during operation.

Modification Hazard

Never modify the 3000SS Sand Shark with Sand Sifter without written consent of LeeBoy. Any modification can affect the safe operation of the 3000SS Sand Shark with Sand Sifter and may cause personal injury or death.

Exposure Hazard



Always wear personal protective equipment, including appropriate clothing, gloves, work shoes, and eye and hearing protection, as required by the task at hand.

Explosion Hazard



While the engine is running or the battery is charging, hydrogen gas is being produced and can be easily ignited. Keep the area around the battery well-ventilated and keep sparks, open flame and any other form of ignition out of the area.

- Always disconnect the negative (-) battery cable before servicing the Sand Shark.
- Do not start the engine by shorting the starter circuit or any other starting method not stated in this manual. Only use the starting procedure as described in this manual to start the engine.
- Never charge a frozen battery. Always slowly warm the battery to room temperature before charging.

Fire and Explosion Hazard

- Diesel fuel is flammable and explosive under certain conditions.
- Never use a shop rag to catch the fuel.
- Wipe up all spills immediately.
- Never refuel with the engine running.
- Store any containers containing fuel in a well-ventilated area, away from any combustibles or sources of ignition.

Fire Hazard



Have appropriate safety equipment available. Have all fire extinguishers checked periodically for proper operation and/or readiness.

- Always read and follow safety-related precautions found on containers of hazardous substances like parts cleaners, primers, sealants and sealant removers.
- Undersized wiring systems can cause an electrical fire.

WARNING

The safety messages that follow have **WARNING** level hazards.

Exhaust Hazard



All internal combustion engines create carbon monoxide gas during operation and special precautions are required to avoid carbon monoxide poisoning:

- Never block windows, vents or other means of ventilation if the 3000SS Sand Shark with Sand Sifter is operating in an enclosed area.
- Always ensure that all connections are tightened to specifications after repair is made to the exhaust system.

Entanglement/Sever Hazard



Verify there are no people, obstacles or other equipment near the 3000SS Sand Shark with Sand Sifter before starting the engine. Sound the horn as a warning before starting the engine.



If the engine must be serviced while it is operating, remove all jewelry, tie back long hair and keep hands, other body parts and clothing away from moving/rotating parts.

- Always stop the engine before beginning service.
- Verify that all Sand Shark guards and covers are attached properly to the Sand Shark before starting the engine. Do not start the engine if any guards or covers are not properly installed on the Sand Shark.
- If you must run the engine during maintenance procedures, make sure you have a helper to keep bystanders clear of the Sand Shark and make observations of moving parts as requested by the operator.
- Always turn the start switch to the OFF position after operation is complete and remove the key from the switch. Keep the key in your possession when the Sand Shark is not operating.
- Attach a “Do Not Operate” tag near the key switch while performing maintenance on the equipment.
- Never operate the engine while wearing a headset to listen to music or radio because it will be difficult to hear the warning signals.

- Always start the engine or operate the controls while you are seated in the operators seat.

Alcohol and Drug Hazard



Never operate the engine while under the influence of alcohol or drugs, or when ill.

Piercing Hazard



Avoid skin contact with high-pressure hydraulic fluid or diesel fuel spray caused by a hydraulic or fuel system leak such as a broken hydraulic hose or fuel injection line. High-pressure hydraulic fluid or fuel can penetrate your skin and result in serious injury. If you are exposed to high-pressure hydraulic fluid or fuel spray, obtain prompt medical treatment.

- Never check for a hydraulic fluid or fuel leak with your hands. Always use a piece of wood or cardboard. Have your authorized LeeBoy Dealer or distributor repair the damage.

Flying Object Hazard



Always wear eye protection when cleaning the 3000SS Sand Shark with Sand Sifter with compressed air or high-pressure water. Dust, flying debris, compressed air, pressurized water or steam may injure your eyes.

Coolant Hazard



Wear eye protection and rubber gloves when handling engine coolant. If contact with the eyes or skin should occur, flush eyes and wash immediately with clean water.

Burn Hazard



Some of the Sand Shark surfaces become very hot during operation and shortly after shutdown.

- Keep hands and other body parts away from hot Sand Shark surfaces.
- Handle hot components with heat-resistant gloves.

CAUTION

The safety messages that follow have CAUTION level hazards.

Poor Lighting Hazard

Ensure that the work area is adequately illuminated.
Always install wire cages on portable safety lights.

Tool Hazard

Always use tools appropriate for the task at hand and use the correct size tool for loosening or tightening 3000SS Sand Shark with Sand Sifter parts.

NOTICE

The safety messages that follow have NOTICE level hazards.

Any part which is found defective as a result of inspection or any part whose measured value does not satisfy the standard or limit must be replaced.

Always tighten components to the specified torque. Loose parts can cause 3000SS Sand Shark with Sand Sifter damage or cause it to operate improperly.

Only use replacement parts approved by LeeBoy. Other replacement parts may affect warranty coverage.



Follow the guidelines of the EPA or other governmental agencies for the proper disposal of hazardous materials such as engine oil, diesel fuel and engine coolant. Consult the local authorities or reclamation facility.

Clean all accumulated dirt and debris away from the body of the Sand Shark and its components before you inspect the Sand Shark or perform preventive maintenance procedures or repairs. Operating a Sand Shark with accumulated dirt and debris will cause premature wear of Sand Shark components. Accumulated dirt and debris also hinders effective Sand Shark inspection.

Retrieve any tools or parts that may have dropped inside of the Sand Shark to avoid improper Sand Shark operation.

Dispose of hazardous materials in accordance with all applicable laws and regulations. Never dispose of hazardous materials by dumping them into a sewer, on the ground, or into groundwater or waterways.

If any alert indicator illuminates during Sand Shark operation, stop the engine immediately. Determine the cause and repair the problem before continuing to operate the Sand Shark.

SAFETY LABEL LOCATIONS

Safety Precautions

If your Sand Shark has been repainted, it is extremely important that all the decals referring to CAUTION, WARNING, and DANGER be replaced in their proper locations. The illustrations on this page will aid you in determining the proper locations. For additional help,

you should refer to the parts listing in the parts section of this manual and note the description column.

A description of location is provided below for each safety label. For additional instructions, contact your dealer (see also *Safety Label Installation* in Section 7).

NOTE: It is the responsibility of the owner and operator to make sure that all safety labels are readable and located on the Sand Shark and Sand Sifter as designated by LeeBoy.

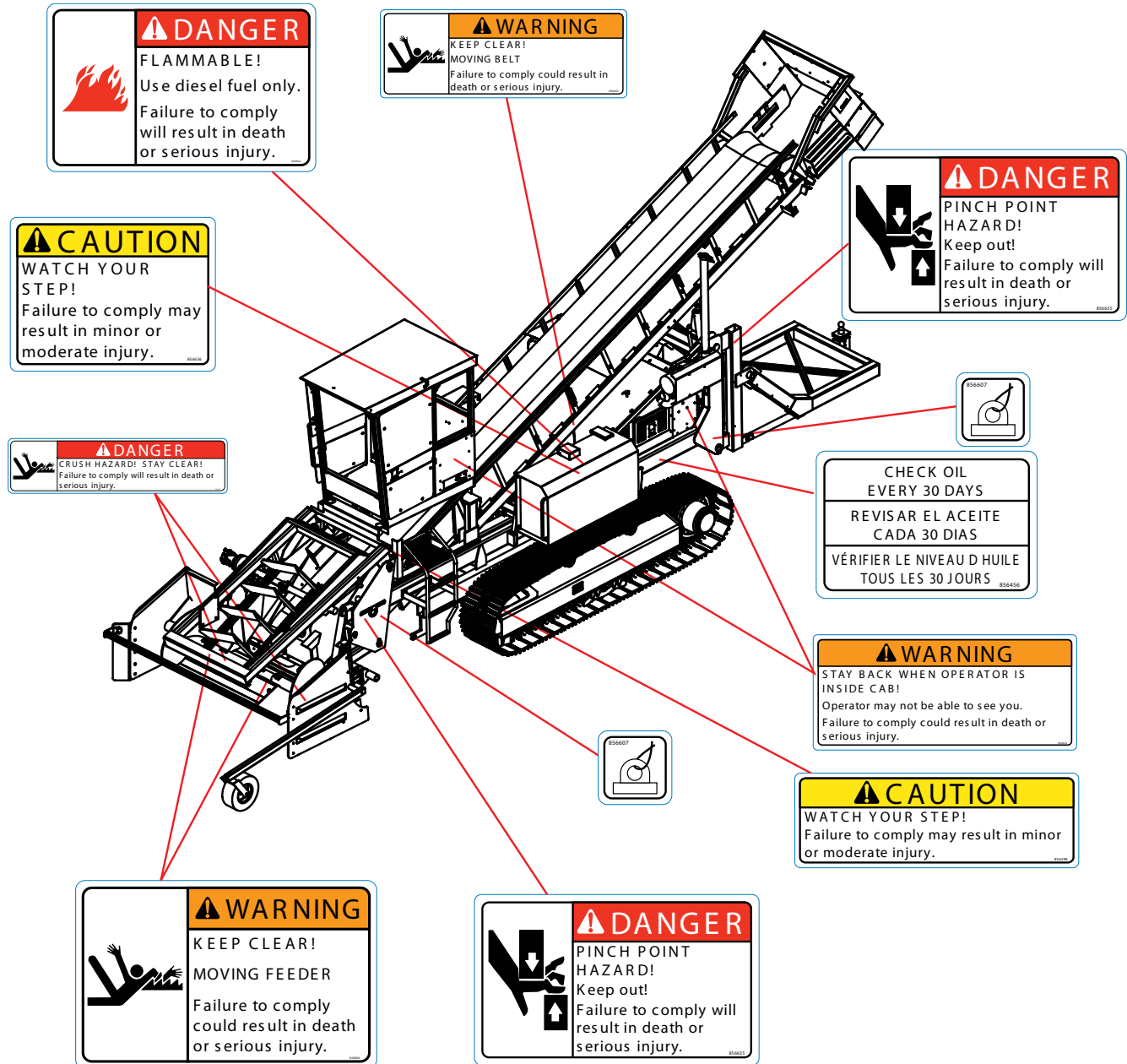

Sand Shark Safety Labels and Safety Label Locations

Figure 2-1

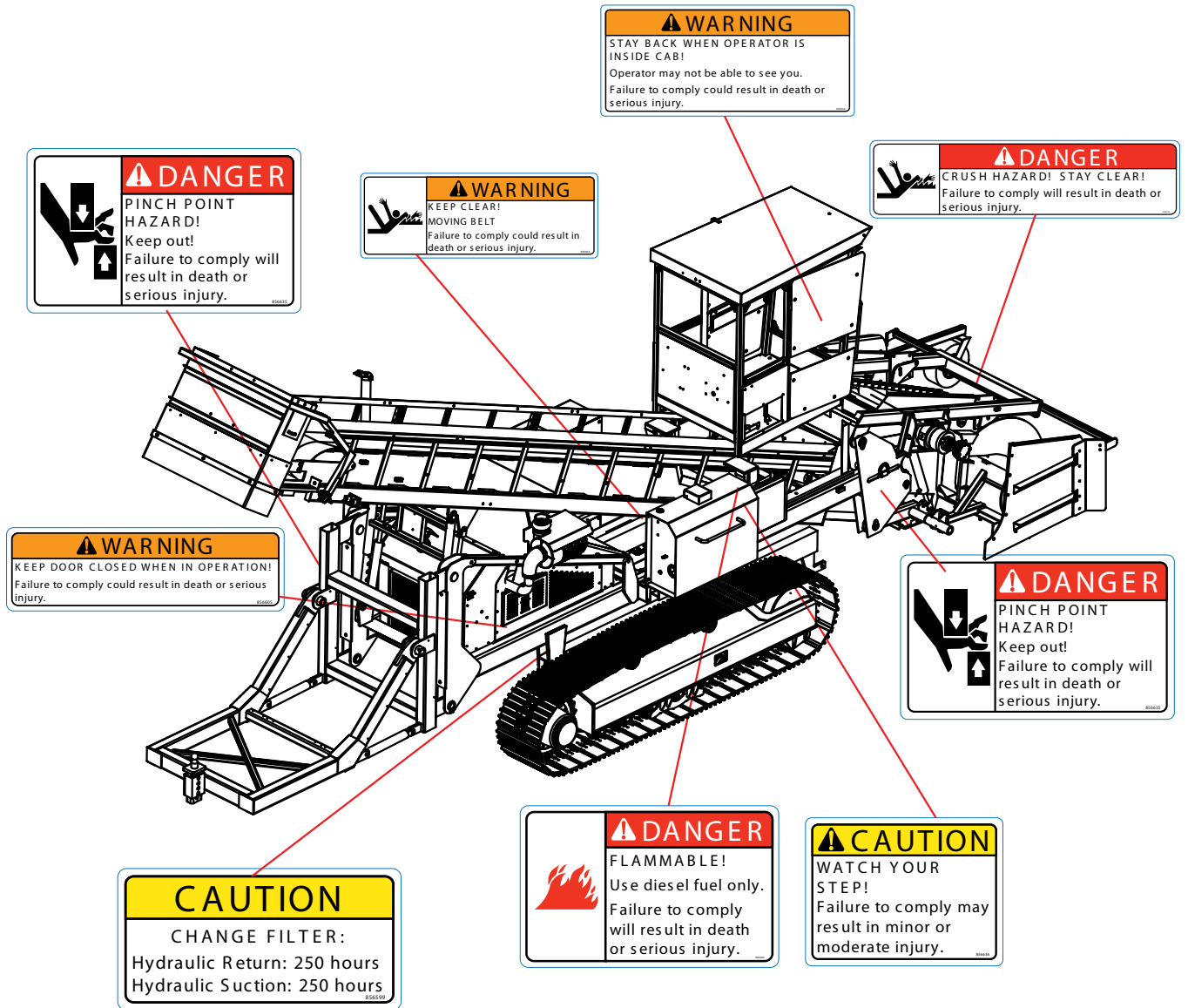

Sand Shark Safety Labels and Safety Label Locations

Figure 2-2

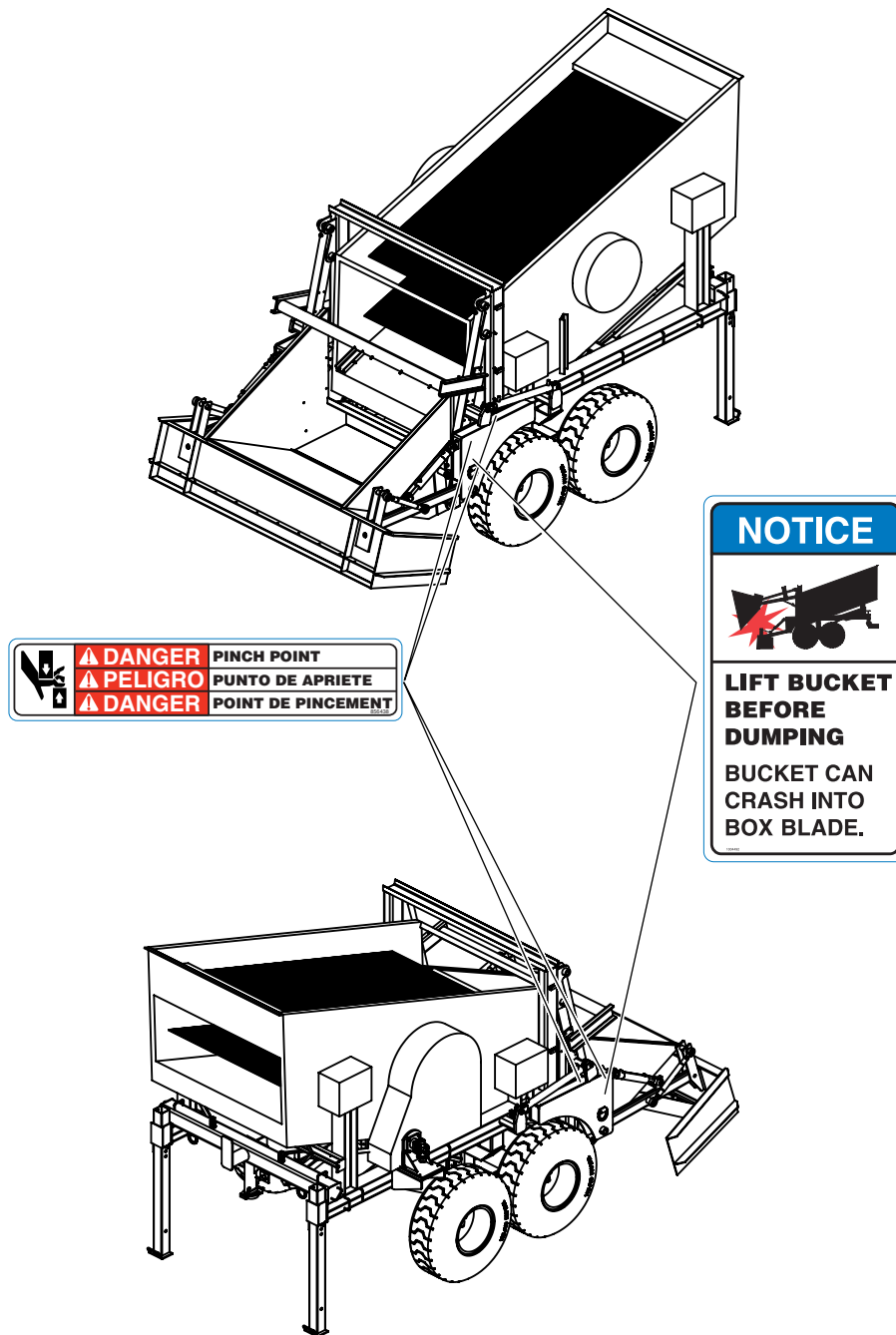

Sifter Safety Labels and Safety Label Locations

Figure 2-3



Section 3

GENERAL INFORMATION

	Page
General Information	3-1
Limited Warranty Policy	3-2
Warranty.	3-2
Limitations.	3-2
Items Not Covered.	3-3
Other Limitations.	3-3
Contact Information	3-4
Record of Ownership	3-4
Nameplate	3-4

LIMITED WARRANTY POLICY

Warranty

1. Subject to the limitations, exclusions, and claims procedures set forth herein, LeeBoy warrants [to the first retail purchaser] that this product will be free from [substantial] defects in materials and workmanship during the warranty period.
2. If a defect in material or workmanship is found, your authorized LeeBoy Dealer is to be notified during the warranty period. LeeBoy and its authorized Dealer will repair or replace any part or component of the unit or part that fails to conform to the warranty during the warranty period.
3. The warranty period will begin on the initial start-up, training and delivery of the unit by the Dealer to the customer, and will expire after twelve (12) months following the delivery of the 3000SS Sand Shark with Sand Sifter to the first retail purchaser. (See Dealer for additional warranty.)
4. Manufacturers' Warranties: Engines are warranted by their manufacturers and may have warranty coverage that differs from that of LeeBoy. LeeBoy does not warrant any engine.
5. Replacement parts furnished by LeeBoy are covered for the remainder of the warranty period applicable to the unit or component in which such parts are installed.
6. LeeBoy has the right to repair any component or part before replacing it with a new one.
7. All new replacement parts purchased by a LeeBoy Dealer will carry a six-month warranty.
8. This Limited Warranty is governed by the laws of the State of North Carolina.

THE FOREGOING WARRANTY IS EXCLUSIVE AND IN LIEU OF ALL OTHER EXPRESSED, STATUTORY AND IMPLIED WARRANTIES APPLICABLE TO UNITS, ENGINES, OR PARTS INCLUDING WITHOUT LIMITATION, ALL IMPLIED WARRANTIES OF MERCHANTABILITY OR FITNESS FOR ANY PARTICULAR USE OR PURPOSE OR AGAINST INFRINGEMENT.

Limitations

LeeBoy has no obligation for:

1. Any defects caused by misuse, misapplication, negligence, accident or failure to maintain or use in accordance with the most current operating instructions.
2. Unauthorized alterations.
3. Defects or failures caused by any replacement parts or attachments not manufactured by or approved by LeeBoy.
4. Failure to conduct normal maintenance and operating service including, without limitation, providing lubricants, coolant, fuel, tune-ups, inspections or adjustments.
5. Unreasonable delay, as established by LeeBoy, in making the applicable units or parts available upon notification of a service notice ordered by same.
6. Warranty Responsibility: The warranty responsibility on all engines rests with the manufacturer of the engine.
7. Warranty and Parts Support: LeeBoy may have support agreements with some engine manufacturers for warranty and parts support. However, LeeBoy does not warrant the engine.
8. This Limited Warranty sets forth your sole remedy in connection with the sale or use of the LeeBoy product covered by this Limited Warranty.
9. This Limited Warranty extends only to the first retail purchaser, and is not transferable.
10. In the event any portion of this Limited Warranty shall be determined to be invalid under any applicable law, such provision shall be deemed null and void and the remainder of the Limited Warranty shall continue in full force and effect.

Items Not Covered

LeeBoy is not responsible for the following:

1. All used units or used parts of any kind.
2. Repairs due to normal wear and tear or brought about by abuse or lack of maintenance of the Machine.
3. Attachments not manufactured or installed by LeeBoy.
4. Liability for incidental or consequential damages of any type including, but not limited to, lost profits or expenses of acquiring replacement equipment.
5. Miscellaneous charges.

Other Limitations

IN NO EVENT, WHETHER AS A RESULT OF BREACH OF CONTRACT OR WARRANTY OR ALLEGED NEGLIGENCE OR LIABILITY WITHOUT FAULT, SHALL LEEBOY BE LIABLE FOR SPECIAL, INCIDENTAL OR CONSEQUENTIAL DAMAGES INCLUDING, WITHOUT LIMITATION, LOSS OF PROFIT OR REVENUE, COST OF CAPITAL, COST OF SUBSTITUTED EQUIPMENT, FACILITIES OR SERVICES, DOWNTIME COSTS, LABOR COSTS OR CLAIMS OF CUSTOMERS, PURCHASERS OR LESSEES FOR SUCH DAMAGES. IN NO EVENT WILL WARRANTY COMPENSATION, OR OTHER DAMAGES AVAILABLE FROM LEEBOY, EXCEED THE PURCHASE PRICE OF THE PRODUCT.

CONTACT INFORMATION

For information regarding parts and repairs about your LeeBoy product, first contact the dealer you purchased your product from.

If you have a persistent problem your dealer is unable to resolve, contact LeeBoy directly.

Record dealer information in the space provided. For additional information about LeeBoy, please visit: www.leeboy.com.

Sales Representative: _____
Dealership Name: _____
Dealership Address: _____
Dealership Phone: _____

RECORD OF OWNERSHIP

Please fill out the following information and use it when you need to contact LeeBoy for service, parts or literature.

Sand Shark Model Number _____
Sand Shark Serial Number: _____
Date of Original Purchase: _____

NAMEPLATE

Nameplate (**Figure 3-1**) contains the specific model number and serial number used to identify the components for any parts or service information.

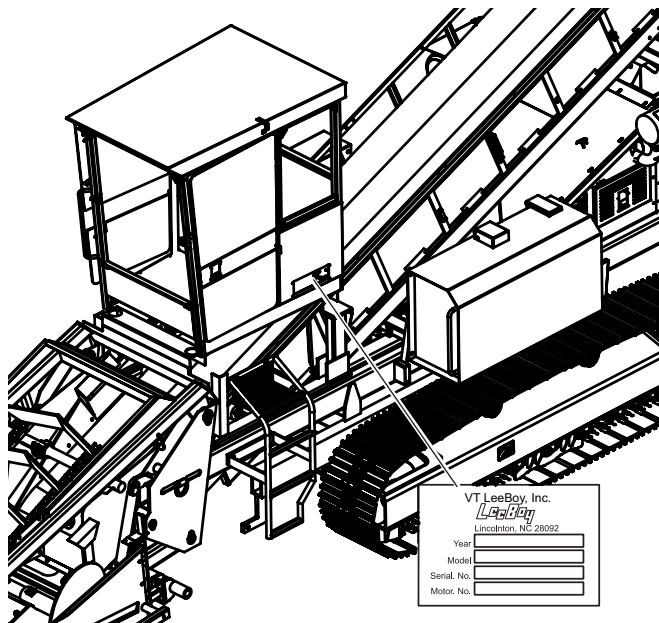

Sand Shark Nameplate Location

Figure 3-1

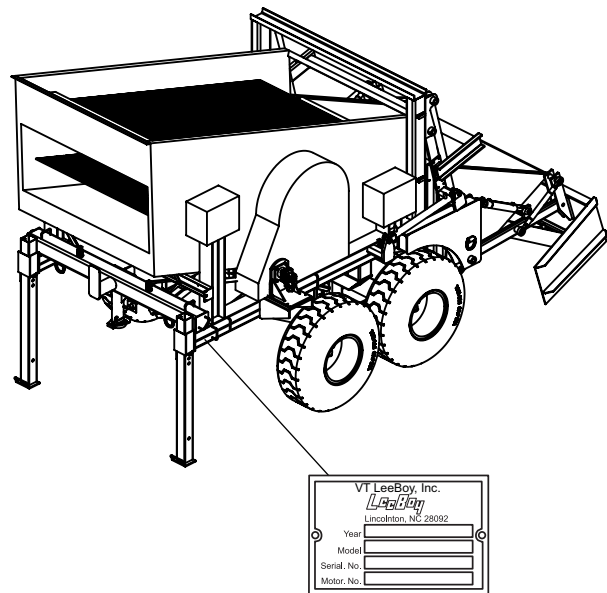

Sifter Nameplate Location

Figure 3-2



Section 4

SPECIFICATIONS

	Page
Specifications	4-1
General Information	4-2
Engine.	4-2
Hydraulic System	4-2
Torque Hubs and Tracks.	4-2
Main Conveyor.	4-2
Operator Cab	4-2
Sifter System	4-2
Flotation Tires	4-3
Specification Charts	4-3
Dimensions	4-6
Torque Specs	4-7
Metric Fasteners.	4-7
Inch Fasteners.	4-8
Hydraulic Fittings	4-9
Full Torque Nut Coupling Installation	4-9

GENERAL INFORMATION

The descriptions and specifications provided in this section are applicable to the LeeBoy Model 3000SS Sand Shark with Sand Sifter.

This section contains a description of how the major components operate. It also includes specifications for the major system components. Included in this section are Sand Shark weights, dimensions, performance, and major system specifications for the Sand Shark.

Engine

The LeeBoy Model 3000SS Sand Shark with Sand Sifter uses a Cummins QSB4.5, Tier 3/Stage III A, four-cylinder engine to drive the hydraulic function pump and steering pump. The engine is mounted near the center of the Sand Shark and is accessible through several access doors in the engine cover.

A fuel lift pump mounted on the engine draws diesel fuel from the fuel tank. The fuel tank is mounted at the rear of the engine compartment.

An air cleaner is mounted on the left side of the pump cover. The air cleaner removes fine particles such as dust, sand, chaff and lint from the air.

As air is taken into the air cleaner assembly, a cyclone type action deposits some of the fine particles in the evacuator mounted on the bottom of the air cleaner housing. The evacuator is held closed during engine operation by suction. When the engine is shut off the weight of the debris helps to open the rubber flaps allowing the debris to fall out. The rubber flaps can also be squeezed to open for cleaning.

Primary and secondary fuel filters remove contaminants from the diesel fuel before the fuel flows to the injection pump for injection into the engine combustion chamber.

A radiator mounted in front of the engine cools the engine. As coolant flows through the radiator, airflow from the engine-driven fan removes heat from the coolant.

Refer to the engine owner's Operation and Maintenance Manual for a complete description of the engine.

Hydraulic System

The Sand Shark is equipped a 52 gallon hydraulic tank that supports all mechanical systems on the machine. These systems control machine movement, and main conveyor height, rotation, and main deflectors.

Torque Hubs and Tracks

The 3000SS Sand Shark drive system contains two torque hubs. The torque hubs provide power to propel the hydrostatically powered self-cleaning crawler type tracks that consist of drive sprockets, rollers, and hydraulically adjustable front idlers. Final drive consists of torque hubs with two-speed hydraulic motors operated by a toggle switch. A fail-safe parking brake is also built into the unit.

Feed System

The augers rotate to assist by moving material from the auger box to the conveyor. The rotational speed of the augers can be controlled from within the operator's cab. Replaceable paddles attached to a chain assembly are driven by a hydrostatically operated gear reduction and drive shaft/sprocket assembly. The feeder chain assembly has float capability.

Main Conveyor

The Main conveyor is independently controlled for variable speed and is raised and lowered hydraulically. The conveyor belt is a heavy duty, reversible, 2-ply polyester cord carcass with rubber covers and includes 1" (25.4 mm) rubber cleats.

Operator Cab

The operator's cab allows easy and convenient control of all functions of the 3000SS Sand Shark with Sand Sifter.

Sifter System

NOTICE

The Sand Sifter should only be towed by the Sand Shark.

The towable sifter system receives the material to be sifted from the main conveyor. Material is spread out on top of the vibrating sifting surface. Smaller particles fall through the screens while larger particles are sifted out and deposited into the hopper at the rear of the Sand Sifter. The rear hopper raises to dump sorted/sifted material to another container (ie: to haul away).

As small particles fall through the sifting screens to the ground, they are initially smoothed by an adjustable pre-strike-off plate mounted in front of the axle. Finally, the sand is returned to its original contour using the remote controlled adjustable box blade at the rear of the sifter.

Wide flotation type tires are used on the sifter to minimize ground pressure and sand compaction.

Electrical System

The electrical system is powered by two 12-volt batteries mounted in the engine compartment. Each battery produces 12 volts DC and maintains 900 cold cranking amps (CCA). An engine mounted alternator capable of 160 amperes charging capacity keeps the battery charged during normal operation. The battery charge

rate can be monitored using the default control screen on the DP200.

SPECIFICATION CHARTS

The specifications provided in this section are applicable to the LeeBoy Model 3000SS Sand Shark with Sand Sifter. Included in this section are specifications for 3000SS Sand Shark weights, dimensions, performance, and torque values for both metric and standard inch fasteners.

CAUTION Replace original equipment only with LeeBoy approved components.

Table 4-1. Dimension Specifications (See Figure 4-1)

ITEM	SPECIFICATION-
Overall Length	34' (1036 cm)
Overall Height (minimum)	10' 5.5" (320 cm)
Overall Height (maximum)	12' 11" (393 cm)
Overall Width (machine)	8' 5" (257 cm)
Overall Width (cab)	4' 4.5" (130 cm)
Weight	28,560 lbs (12,955 kg)
Sifter Unit Weight	12,500 lbs (5,670 kg)

Table 4-2. Performance Specifications

ITEM	SPECIFICATION
Travel Speed (Highway)	0-300 FPM
Working Speed	15-45 FPM

Table 4-3. Cummins Tier 3 Engine Specifications

ITEM	SPECIFICATION
Manufacturer and Model	Cummins, QSB4.5
Emission Regulation	Tier 3 / Stage III A
Type	Vertical 4-cycle Liquid Cooled Diesel
Number of Cylinders	4
Bore, Stroke, and Displacement	4.02" (102 mm) ; 4.72" (120 mm); 275 in ³ (4506 cm ³)
Engine Oil Type	15W-40
Firing Order	1, 3, 4, 2
Oil Capacity	11.6 quarts (11.0 L)
Fuel Filter Type	Cummins Diesel



Table 4-4. Electrical Specifications

ITEM	SPECIFICATION
Battery	Two, Maintenance Free
Battery Ampere Hour Rating	900 CCA
Battery Voltage	12 Volts
Alternator Type and Voltage	12 Volt, negative ground
Alternator Output Amperage	160 Amps
Alternator Fan Belt Tension	Automatic belt tension mechanism keeps serpentine belt under tension at all times
Starter Voltage and Type	12 Volt, negative ground

Table 4-5. Machine System Capacity Specifications

ITEM	SPECIFICATION
Engine Lubrication Oil - with oil filter	11.6 quarts (11.0 L)
Hydraulic Oil Reservoir	52 gal (75.7 L)
Fuel	104 gal (393.6 L)
Cooling System	5.5 Gallons (20.8 L)
Double Pump Drive	4 quarts
Torque Hub Feeder Drive	1.0 quart
Torque Hub Conveyor Drive	1.0 quart
Anitfreeze	Glycol based, Red, Extended Life, 5.5 gal (20.8 L)

Table 4-6. Hydraulic Pressures Specifications

ITEM	SPECIFICATION
Brakes	1500 PSI (117 Bar)

Table 4-7. Lubricant Specifications

ITEM	SPECIFICATION
Engine Oil	15W-40
Hydraulic Oil	EAL 224H All Weather Hydraulic Oil
Torque Hub	85W90
Grease	Shell Avania EP Grease or Equivalent
Chain Lube	Chain Lube
Double Pump Drive	85W90
Air Conditioner	2.75 lbs AC Refrigerant
Air Conditioner	4 oz. AC oil
Sifter Grease	Mobil SHC 460
Torque Hub	50 WT Gear Oil

Table 4-8. Miscellaneous Specifications

ITEM	SPECIFICATION
Brakes - Service	Utilizes hydrostatic transmission
Brakes - Parking	Multiple disk on torque hub
Tracks	Hydraulic power assisted
Sifter Tire	16.5L-16.1 X 14.0, 10-Ply, Low Profile, Tubeless
Tire Pressure	33 to 36 PSI
Wheel Nut	9/16", Torque to 150 - 170 ft/lbs
Shaker Speed	1150 to 1350 RPM (preset at factory - do NOT change)
Drive Belt Tension	1/2" to 1" deflection at 5 lbs of forces
Screen Opening Size	3/8" Top Screen, 1/8" Lower Screen (other screen sizes are available)
Screen Tension Adjustment	2-1/8" to 2-3/16" tension spring length
Hitch Coupler	2-5/16" diameter
Motor Rotation	Clockwise
Optimal Sifter Angle	18 degrees from horizontal (FIG. X-X)
Conveyor - Control	Variable Speed
Conveyor - Belt width	30" (76.2 cm)
Conveyor - Belt length	58' 3" (17.8 m)
Conveyor - Discharge	Hydraulically raised 10' - 11' (3 - 3.4 m)
Cab - Enclosure	Fully enclosed with safety glass
Cab - Seat	Padded with seat belt
Cab - Windshield wipers	Front and Rear
Cab - Lights	Headlights, tail lights, turn indicators, work lights and instrument lights
Sifter Remote - Frequency	902-928MHz
Sifter Remote - Range (Line of Sight)	500 ft
Sifter Remote - Battery Type	Battery Type 3 "D" size alkaline or rechargeable
Sifter Remote - Battery Life	Battery Life (Alkaline) Standard range = Standby, 80 hrs; Transmit, 35 hrs
Sifter Remote - LED Indicator	Led Indicator: Flashing = normal; Double blink = battery low

DIMENSIONS

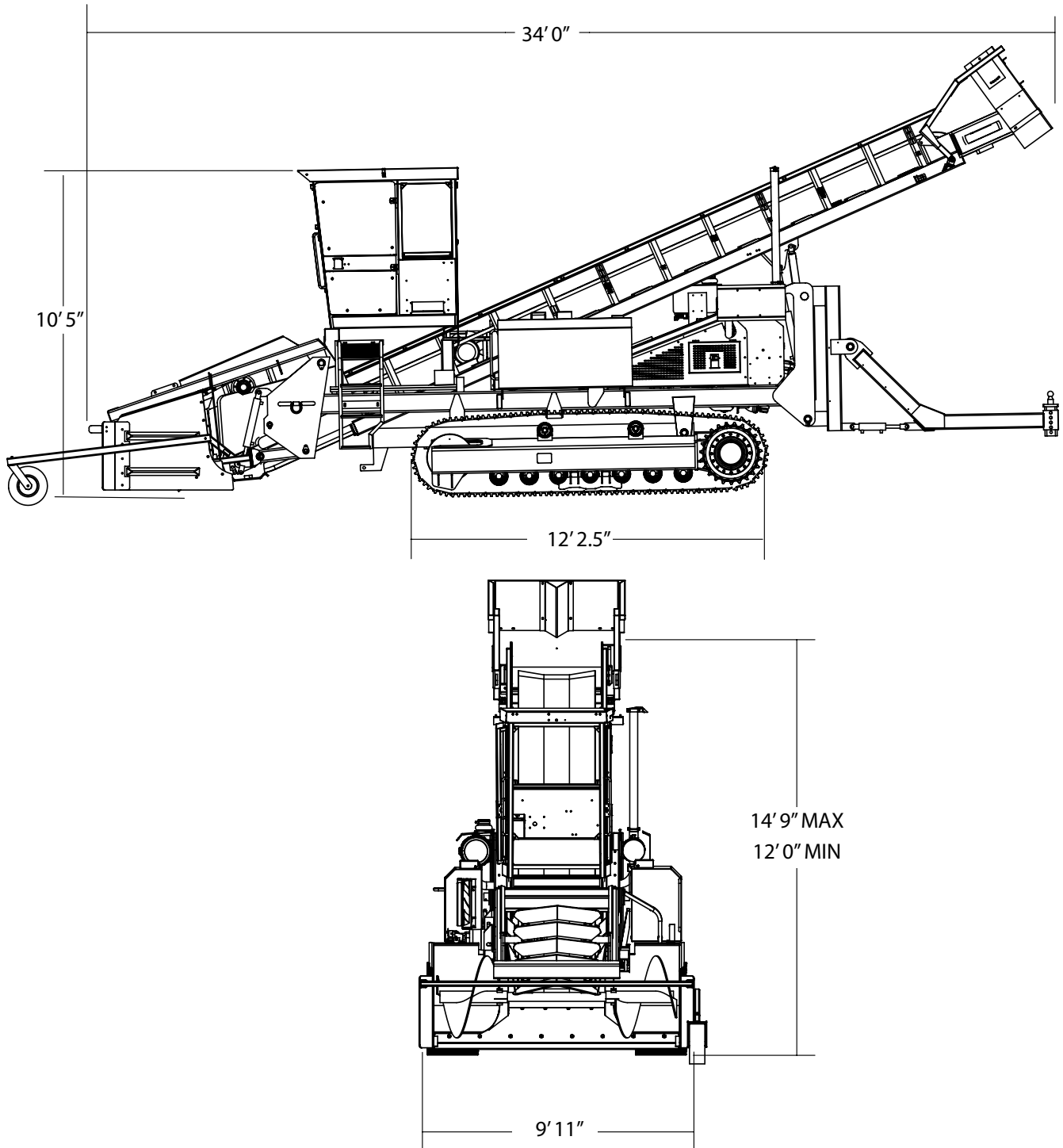

3000SS Sand Shark Dimensions

Figure 4-1

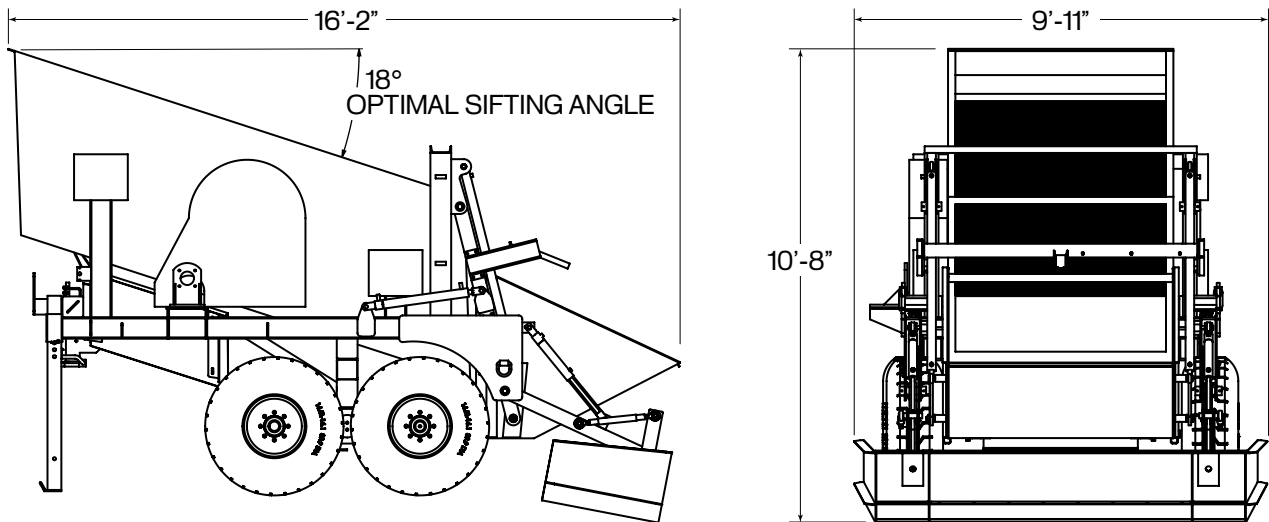

Sand Sifter Dimensions

Figure 4-2

TORQUE SPECS

Metric Fasteners

⚠ WARNING The following Table lists torque values for standard hardware and are intended as a guide for average application involving typical stresses

and machined surfaces. Values are based on physical limitations of clean, plated and lubricated hardware. In all cases, when an individual torque value is specified, it should be followed instead of values given in this table.

⚠ CAUTION Replace original equipment with hardware of equal grade.

Table 4-9. Torque Specifications For Metric Fasteners

NOMINAL SIZE & PITCH	CLASS 8.8 (GRADE 5 EQUIVALENT)				CLASS 10.9 (GRADE 8 EQUIVALENT)			
	TORQUE FT. LBS.		TORQUE N•m		TORQUE FT. LBS.		TORQUE N•m	
	Dry	Lubed	Dry	Lubed	Dry	Lubed	Dry	Lubed
M4 x 0.7	2.27	1.70	3.07	2.30	2.27	2.31	4.17	3.13
M5 x 0.8	4.58	3.43	6.20	4.65	6.22	4.67	8.43	6.33
M6 x 1	7.75	5.83	10.5	7.90	10.60	7.97	14.3	10.8
M8 x 1.25	18.89	14.17	25.6	19.2	18.95	19.26	34.8	26.1
M10 x 1.25	39.11	29.52	53.0	40.1	53.87	40.59	73.0	55.0
M12 x 1.75	64.94	48.71	88.0	66.0	88.56	66.42	120.0	90.0
M14 x 2	103.32	77.49	140.0	105.0	140.22	107.01	190.0	145.0
M16 x 2	162.36	121.77	220.0	165.0	221.40	166.05	300.0	225.0
M20 x 2.5	317.34	236.16	430.0	320.0	428.04	321.03	580.0	435.0
M24 x 3	516.12	409.59	740.0	555.0	754.38	557.19	1010.0	755.0
M27 x 3	797.04	597.78	1080.0	810.0	1084.86	811.80	1470.0	1100.0
M30 x 3.5	1084.86	811.80	1470.0	1100.0	1476.00	1107.00	2000.0	1500.0

Inch Fasteners

⚠ WARNING The following Table lists torque values for standard hardware and are intended as a guide for average application involving typical stresses and machined surfaces. Values are based on

physical limitations of clean, plated and lubricated hardware. In all cases, when an individual torque value is specified, it should be followed instead of values given in this table.

⚠ CAUTION Replace original equipment with hardware of equal grade.

Table 4-10. Torque Specifications For Standard Inch Fasteners

SIZE	THREAD	CAPSCREWS: SAE GRADE 5				CAPSCREWS: SAE GRADE 8			
		TORQUE FT. LBS.		TORQUE N•m		TORQUE FT. LBS.		TORQUE N•m	
		Dry	Lubed	Dry	Lubed	Dry	Lubed	Dry	Lubed
1/4	20 UNC	8	6	11	9	12	9	16	12
	28 UNF	10	7	13	10	14	10	19	14
5/16	18 UNC	17	13	24	18	25	18	33	25
	24 UNF	19	14	26	20	27	20	37	28
3/8	16 UNC	31	23	42	31	44	33	59	44
	24 UNF	35	26	47	36	49	37	67	50
7/16	14 UNC	49	37	67	50	70	52	95	71
	20 UNF	55	41	75	56	78	58	105	79
1/2	13 UNC	75	57	100	77	105	80	145	110
	20 UNF	85	64	115	86	120	90	165	120
9/16	12 UNC	110	82	145	110	155	115	210	155
	18 UNF	120	91	165	125	170	130	230	175
5/8	11 UNC	150	115	205	155	210	160	285	215
	18 UNF	170	130	230	175	240	180	325	245
3/4	10 UNC	265	200	360	270	375	280	510	380
	16 UNF	295	225	405	300	420	315	570	425
7/8	9 UNC	430	320	580	435	605	455	820	615
	14 UNF	475	355	640	480	670	500	905	680
1	8 UNC	645	485	875	655	910	680	1230	925
	14 UNF	720	540	980	735	1020	765	1380	1040
1-1/8	7 UNC	795	595	1080	805	1290	965	1750	1310
	12 UNF	890	670	1210	905	1440	1080	1960	1470
1-1/4	7 UNC	1120	840	1520	1140	1820	1360	2460	1850
	12 UNF	1240	930	1680	1260	2010	1500	2730	2050
1-3/8	6 UNC	1470	1100	1990	1490	2380	1780	3230	2420
	12 UNF	1670	1250	2270	1700	2710	2040	3680	2760
1-1/2	6 UNC	1950	1460	2640	1980	3160	2370	4290	3210
	12 UNF	2190	1650	2970	2230	3560	2670	4820	3620

Hydraulic Fittings

Tightening Flare Type Tube Fittings

1. Check the flare and flare seat for defects that might cause leakage.
2. Align tube with fitting before tightening.
3. Lubricate connection and hand tighten swivel nut until snug.

4. To prevent twisting the tube(s), use two wrenches. Place one wrench on the connector body and with the second, tighten the swivel nut to the torque shown in **Table 4-11. Torque Specifications For Flare Type Tube Fittings.**

NOTE: The torque values shown are based on lubricated connections as in assembly.

Table 4-11. Torque Specifications For Flare Type Tube Fittings

TUBE SIZE OD	NUT SIZE (ACROSS FLATS)	TORQUE VALUE		RECOMMENDED TURNS TO TIGHTEN (AFTER FINGER TIGHTENING)	
		(N•m)	(lb-ft)	(N•m)	(lb-ft)
(in)	(in)				
3/16	7/16	8	6	1	1/6
1/4	9/16	12	9	1	1/6
5/16	5/8	16	12	1	1/6
3/8	11/16	24	15	1	1/6
1/2	7/8	46	34	1	1/6
5/8	1	62	46	1	1/6
3/4	1 1/4	102	75	3/4	1/8
7/8	1 3/8	122	90	3/4	1/8

Full Torque Nut Coupling Installation

The only completely reliable method of creating a consistent leak free, long lasting connection is to ensure that the coupling is brought to the proper torque.

The best method of ensuring a coupling is brought to the proper torque is to use a torque wrench with crowfoot. To ensure the proper torque is met, use the flats method of torque verification. Flats method may be used alone in situations where a torque wrench is inaccessible or unavailable.

There are 7 steps involved in proper coupling installation:

5. Determine the correct torque value for your coupling.

NOTE: Only use the torque values specified from the manufacturer, do not use SAE torque recommendations.

The minimum torque values are adequate for sealing in most applications, and the maximum torque values should never be exceeded.

6. Calculate the correct torque wrench setting using (see **Equations** in Section 4).

NOTE: The most straight forward method of determining the correct torque setting is to multiply the desired torque by the length of the wrench from the center of the handle to the center of the drive (L) divided by the length of the wrench from the center of the handle to the crowfoot center (LA), (**Figure 4-3**).

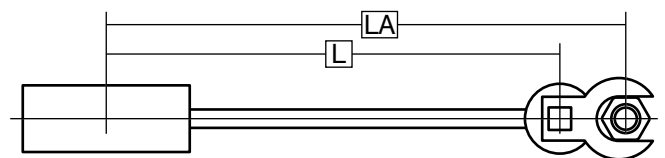

Torque Wrench - Crowfoot

Figure 4-3

NOTE: Torque Wrench Setting = Desired Torque * L / LA

7. Ensure that the seal face and threads are clean and in good condition. Do not lubricate coupling threads.

NOTE: O-Rings should be lubricated with light oil, but threads should be completely dry unless making pipe thread connections (interference seal).

Attach the male end of the hose onto the equipment first, since it may be necessary to rotate the entire hose assembly to tighten the male threads. Then route the hose into position while avoiding twisting the hose.

8. Hand tighten the connection by bringing seal face in contact and rotating the nut by hand until it stops.

NOTE: By definition hand tight is 0.3-1 ft-lb or when the seal faces are touching and with the threads engaged the hex can no longer be rotated by hand.

9. Mark a line across the coupling nut and backup hex for flats method verification of coupling torque (**Figure 4-4**).
10. Apply a wrench to the backup hex to prevent the coupling and hose from moving while tightening the nut with a torque wrench.

NOTICE Failure to retain the backup hex during installation will also result in additional clamp load force that could cause damage to the seal face.

NOTE: The coupling nut must be in motion for an accurate torque reading. If the nut is stopped before final torque value is achieved, it must be loosened and retightened until the torque is attained while the nut is in motion.

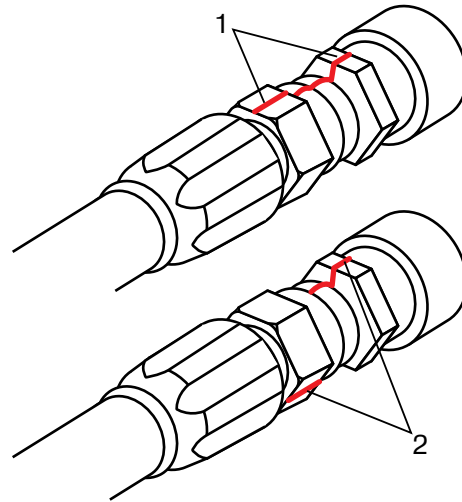

Flats Method Tightening

Figure 4-4

1 - Mark Line on Nut

2 - Example 2 Flats difference

11. If a torque wrench cannot fit into the coupling area or if it is unavailable, flats method may be used to ensure that the coupling is properly tightened, as shown in **Figure 4-4**.

NOTE: The mark placed on the nut and backup hex after hand tightening should have rotated 1 to 1.5 flats during final tightening. At this point in time, if desired, the nut and backup hex may be marked to indicate if the coupling loosens over time.

Table 4-12. Torque Specifications For US Style Coupling Terminations

JIC, SAE 45°, ORFS, O-Ring Boss, Gates Adapterless and MegaSeal										
Dash Size	JIC 37°, SAE 45° & MegaSeal (steel)		JIC 37°, SAE 45° & Mega-Seal (steel)		Flat Face O-Ring Seal (Steel)		SAE O-Ring Boss (Steel) & Gates Adapterless ≤ 4000 PSI		SAE O-Ring Boss (Steel) & Gates Adapterless > 4000 PSI	
1/16 Inch	ft-Lb		ft-Lb		ft-Lb		ft-Lb		ft-Lb	
	Min	Max	Min	Max	Min	Max	Min	Max	Min	Max
-3									8	10
-4	10	11	5	6	10	12	14	16	14	16
-5	13	15	7	9					18	20
-6	17	19	12	15	18	20	24	26	24	26
-8	34	38	20	24	32	40	37	44	50	60
-10	50	56	34	40	46	56	50	60	72	80
-12	70	78	53	60	65	80	75	83	125	135
-14					65	80			160	180
-16	94	104	74	82	92	105	111	125	200	220
-20	124	138	75	83	125	140	133	152	210	280
-24	156	173	79	87	150	180	156	184	270	360
-32	219	243	158	175						

Table 4-13. Torque Specifications For DIN 24, DIN 60, and Inverted Cone Style Coupling Terminations

DIN 24, DIN 60, and Inverted Cone			
Size		Torque	
mm		ft-Lb	
Light Series Tube OD	Heavy Series Tube OD	Min	Max
6		7	15
8		15	26
10	8	18	30
12	10	22	33
14	12	26	37
15	14	30	52
	16	30	52
18	20	44	74
22	25	59	89
28	30	74	111
	38	74	162
35		133	184
42		148	221

Table 4-14. Torque Specifications For 4-Bolt Flange Connections

4-Bolt Flanges		
Dash Size	Bolt Size	Torque
1/16 Inch	Inch	ft-Lb
-8	0.31	17
-12	0.38	26
-16	0.44	43
-20	0.50	65
-24	0.63	130
-32	0.75	220

- Align faces and finger tighten bolts before applying final torque in a pattern. The seal faces must be parallel with even bolt tension to seal properly.
- Torque values apply to bolts which are plated or coated in light engine oil.
- Before assembly lubricate O-Ring with light oil (SAE 10W or 20W).

Table 4-15. Torque Specifications For SAE Male Flareless Assembly (MFA)

SAE Male Flareless Assembly (MFA)
After hand tight rotate nut one full turn (8 flats)

Table 4-16. Torque Specifications For NPTF Dry Seal Pipe Threads

NPTF	
Dash Size	Max Torque
1/16 Inch	ft-Lb
-2	20
-4	25
-6	35
-8	45
-12	55
-16	65
-20	80
-24	95
-32	120

1. The torque values obtained from tightening pipe threads can vary considerably depending on thread condition. Adequate sealing can occur at values much lower than the maximum values listed above. Only enough torque to achieve adequate sealing should be used.
2. When using a male tapered pipe thread with a female straight or parallel pipe thread, maximum values are 50% of those listed in the table.
3. If thread sealant is used, maximum values shown should be decreased by 25%.

Table 4-17. Torque Specifications For BSP 30° Inverted Cone and JIS Coupling Terminations

BSP 30° Inverted Cone and JIS		
Dash Size	Torque	
mm	ft-Lb	
1/16 Inch	Min	Max
-2	7	9
-4	11	18
-6	19	28
-8	30	36
-10	37	44
-12	50	60
-16	79	95
-20	127	152
-24	167	190
-32	262	314

Table 4-18. Flats Method Values For Selected Terminations

Flats Method Values		
Termination Type	Dash Size	Flats
	1/16 Inch	
JIC	4	1.5 - 1.75
JIC	6	1.0 - 1.5
JIC	8	1.5 - 1.75
JIC	10	1.0 - 1.5
JIC	12	1.0 - 1.5
JIC	16	.75 - 1.0
JIC	20	.75 - 1.0
JIC	24	.75 - 1.0
JIC	32	.75 - 1.0
JIS	4	.5 - 1.5

1. Seal faces must be in contact and the fitting fully hand tightened before marking flats.
2. Flats method is most accurate for the first assembly cycle, for multiple disassembly/assembly cycles torque values are more reliable.
3. Tightening 2 flats or more is analogous to sever over torque and may damage seal faces.

Determining Torque Setting

There are several methods of determining the correct setting on the torque wrench when using a crowfoot. All of the methods involve making the setting proportional to the effective change in length of the wrench multiplied by the desired final torque.

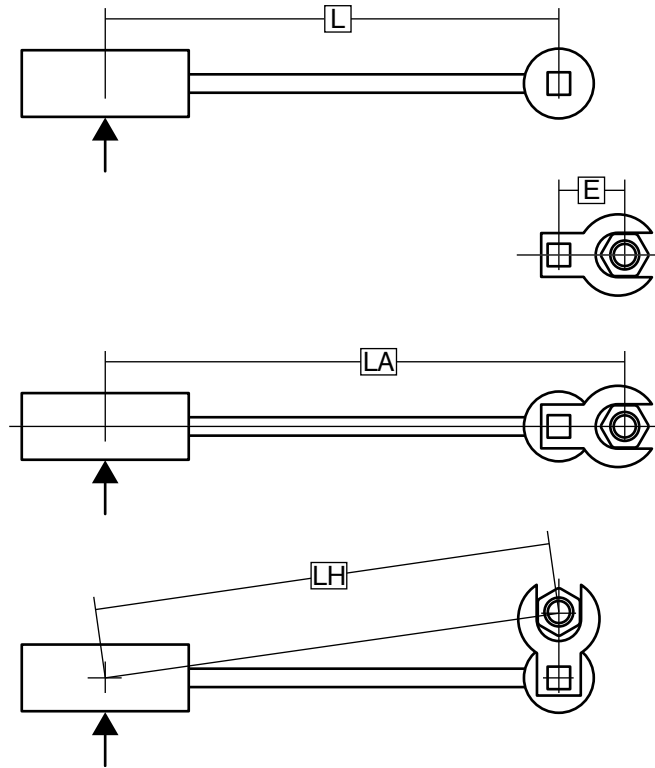

Measurements Needed

Figure 4-5

L = Distance from center of torque wrench handle to the center of socket drive

E = Distance from center of socket drive to the center of crowfoot

LA = Distance from center of torque wrench handle to the center of crowfoot

LH = Distance from center of torque wrench handle to the center of crowfoot, when mounted at 90°

TD = Desired torque at the fitting

TS = Torque setting indicated on wrench

Equations

Equation 1

Torque setting if the crowfoot is placed in line with respect to the wrench:

$$TS = TD * L / LA$$

or

$$TS = TD * L / (L+E)$$

Equation 2

Torque setting if the crowfoot is placed at 90° with respect to the wrench

$$TS = TD * L / LH$$

or

$$TS = TD * L / \sqrt{(L^2 + E^2)}$$

Equation 3

To estimate the crowfoot size (E)

$$E = \text{Drive Size} * 0.5 + \text{Distance between Drive \& Open End} + \text{Wrench Size} * 0.5774$$

NOTES



Section 5

COMPONENT LOCATION

	Page
Component Location	5-1
Control Panels	5-2
Left Operator Control Panel	5-4
Remote Video Monitor	5-6
Switch and Indicator Panel	5-8
Travel Control Panel	5-10
TopCon V Control	5-12
Sifter Remote Control	5-16

CONTROL PANELS

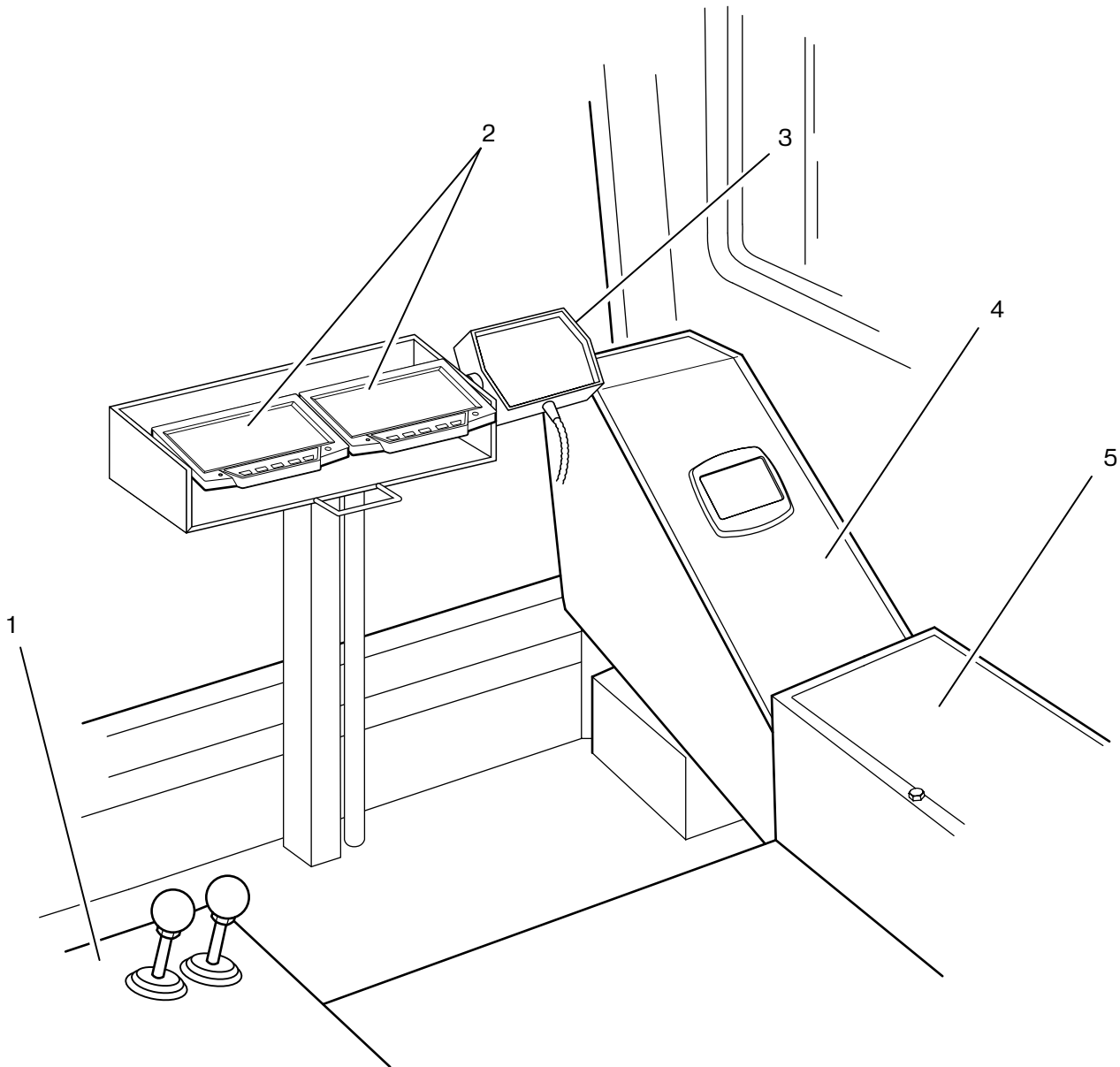

Location of Control Panels

Figure 5-1

- 1 - Travel Control Panel
- 2 - Remote Video Monitor
- 3 - TopCon V Control
- 4 - Switch and Indicator Panel
- 5 - Auger / Feeder Control Panel

Table 5-1. Control Panels

ITEM NO.	CONTROL NAME	FUNCTION
1	Travel Control Panel	Contains direction and speed control joysticks, gear selection (Figure 5-2), (see Sand Shark Operation in Section 6)
2	Remote Video Monitors	Shows images from remote cameras located around the machine (Figure 5-3)
3	TopCon V Control	Controls Moldboard depth front of Sand Shark, (Figure 5-6)
4	Switch and Indicator Panel	Contains various switches and indicators (Figure 5-4), (see Sand Shark Operation in Section 6)
5	Auger / Feeder Control Panel	Contains the Auger/Feeder control levers and battery disconnect switch (Figure 5-2), (see Sand Shark Operation in Section 6)

LEFT OPERATOR CONTROL PANEL

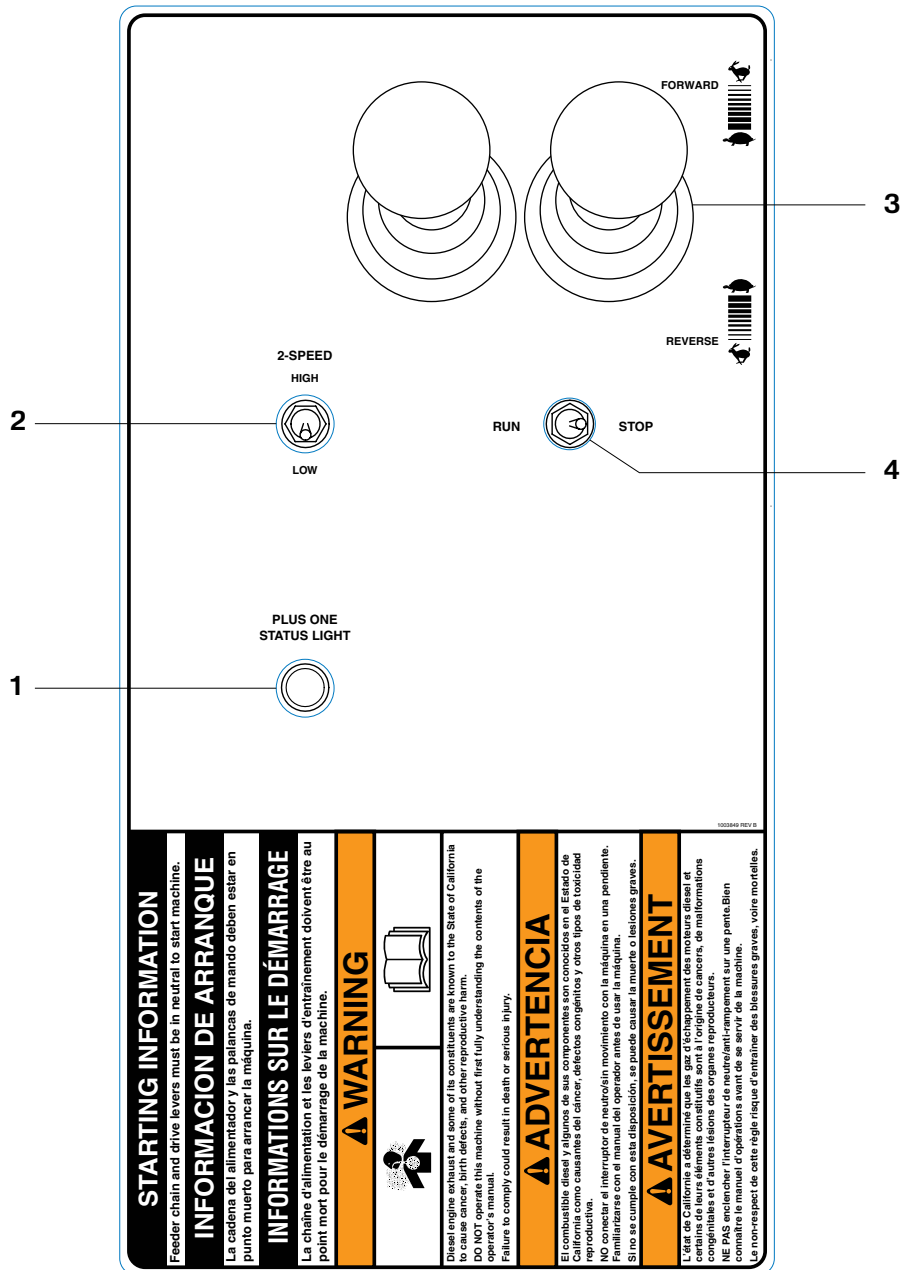

Left Operator Panel

Figure 5-2

1 - Plus One Status Light

2 - 2-Speed Switch

3 - Forward / Reverse Joysticks

4 - Run / Stop Switch

Table 5-2. Left Operator Panel

ITEM NO.	CONTROL NAME	FUNCTION
1	Plus One Status Light	Indicates when Plus One is active
2	2-Speed Switch	Press up for High speed. Press down for Low speed
3	Forward / Reverse Joysticks	Control left and right track speed and direction (see Sand Shark Operation in Section 6)
4	Run / Stop Switch	<p>Move switch to the STOP position to stop the 3000SS Sand Shark with Sand Sifer from traveling and to deactivate the console.</p> <p>NOTE: Switch must be in the STOP position before exiting the unit. Place joysticks in the neutral position before releasing the STOP button, failing to place joysticks in a neutral will cause unit to resume its previous speed and direction prior to stopping the unit.</p> <p>NOTE: If the position of the joysticks has NOT changed from the time that the RUN/STOP switch is moved to the STOP position and then later switched to the RUN position, then 3000SS Sand Shark will resume travel at the same speed of travel when the switch is set to the RUN position.</p> <p>If the position of the joysticks HAS changed from the time that the RUN/STOP switch is moved to the STOP position then later switched to the RUN position, the 3000SS Sand Shark travel function will be temporarily disabled until joysticks are returned to the NEUTRAL position.</p> <p>⚠ WARNING Sudden deceleration will occur when Run / Stop Switch is moved to the STOP position when travelling at high speeds. Operator may be thrown from seat causing personal injury. Operator must always secure seat belt while operating the 3000SS Sand Shark.</p>

REMOTE VIDEO MONITOR

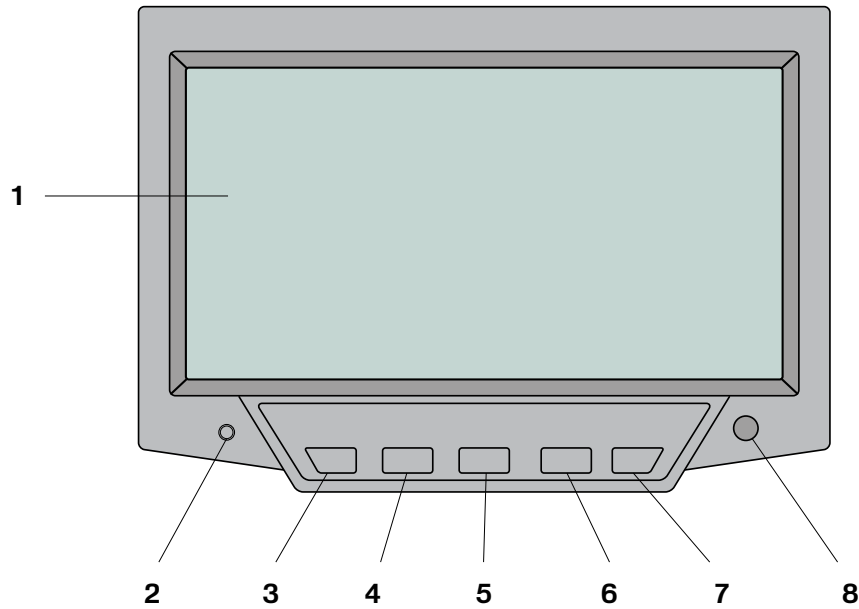

Location of Controls

Figure 5-3

- 1 - Monitor
- 2 - LED Indicator Light
- 3 - CAM Select
- 4 - Menu
- 5 - (-) Minus
- 6 - (+) Plus
- 7 - MIR/NOR
- 8 - Day/Night Sensor

Table 5-3. Main Dash Panel

ITEM NO.	CONTROL NAME	FUNCTION
1	Monitor	Displays menu items, camera views
2	LED Indicator Light	Indicates when CCTV is ON
3	CAM Select	Toggles between CAM1/CAM2
4	Menu	Selects and navigates menu items
5	(-) Minus	Navigates menu items
6	(+) Plus	Navigates menu items
7	MIR/NOR	Toggles between MIRROR and NORMAL view modes
8	Day/Night Sensor	Automatically adjusts brightness of monitor

SWITCH AND INDICATOR PANEL

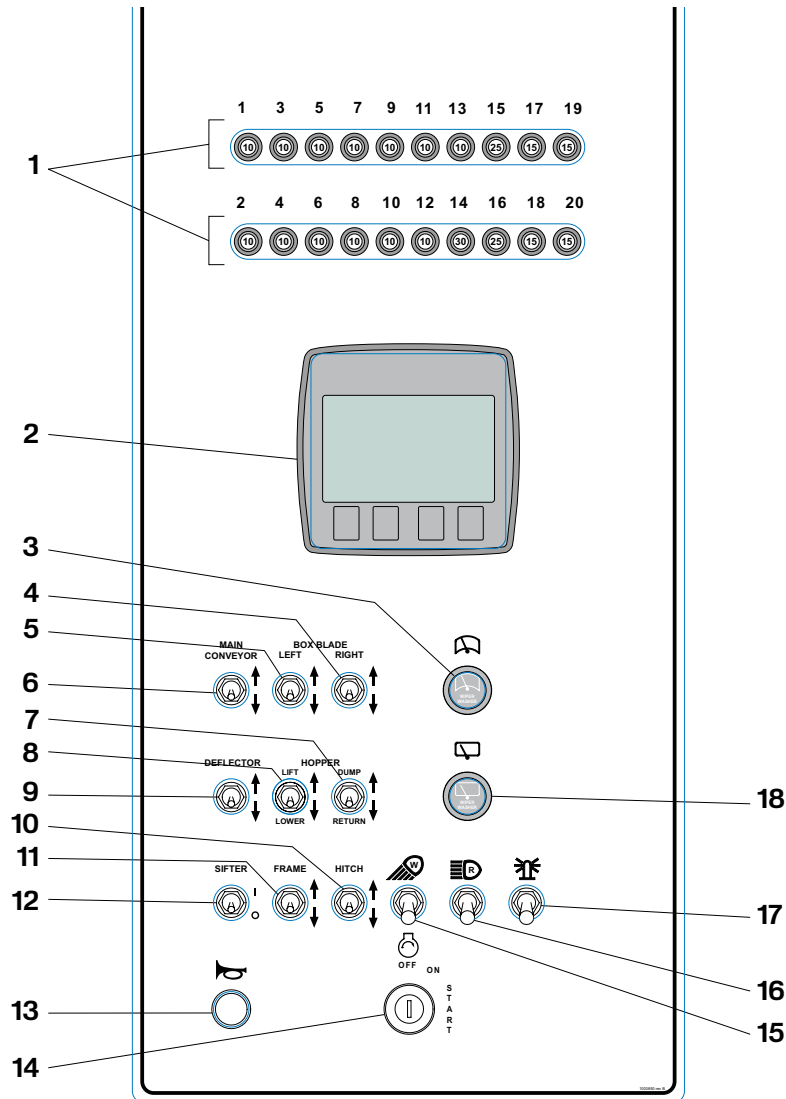

Location of Controls

Figure 5-4

- 1 - Circuit Breaker Resets
- 2 - Display Screen
- 3 - Front Wiper/Washer
- 4 - Box Blade Right (Up/Down)
- 5 - Box Blade Left (Up/Down)
- 6 - Main Conveyor Lift
- 7 - Hopper Dump / Return
- 8 - Hopper Lift / Lower
- 9 - Deflector Switch

- 10 - Hitch Switch (Raise/Lower)
- 11 - Frame Switch (Raise/Lower)
- 12 - Sifter System Switch
- 13 - Horn Button
- 14 - Key Switch
- 15 - Front Work Light Switch
- 16 - Rear Work Light Switch
- 17 - Beacon Light Switch
- 18 - Rear Wiper/Washer

Table 5-4. Main Dash Panel

ITEM NO.	CONTROL NAME	FUNCTION
1	Circuit Breaker Resets	Press to reset tripped circuits
2	Display Screen	Visual display of Tachometer, Voltmeter, Fuel Level, Temperature Gauge, Pressure Gauge and Warning Indicators
3	Front Wiper/Washer	Rotate CW to turn wipers on. Press button to activate Washer.
4	Box Blade Right (Up/Down)	Press up to lift Right Box Blade. Press down to lower Right Box Blade.
5	Box Blade Left (Up/Down)	Press up to lift Left Box Blade. Press down to lower Left Box Blade.
6	Main Conveyor Lift	Press up to lift conveyor. Press down to lower conveyor.
7	Hopper Dump / Return	Press up to dump (tilt down) hopper contents. Press down to return (tilt up) hopper contents.
8	Hopper Lift / Lower	Press up to lift Hopper. Press down to lower Hopper.
9	Deflector Switch	Controls the main deflector position. Up moves deflector up. Down moves deflector down.
10	Hitch Switch (Raise/Lower)	Press up to raise hitch. Press down to lower hitch.
11	Frame Lift / Lower Switch (Raise/Lower)	Press up to lift frame. Press down to lower frame.
12	Sifter System Switch	Press up to turn vibrating screen system on. Press down to turn screen system off.
13	Horn Button	Press to sound horn.
14	Key Switch	Starts engine.
15	Front Work Light Switch	Press up to turn on Front Work light. Color should be white.
16	Rear Work Light Switch	Press up to turn on Rear Work light. Color should be red.
17	Beacon Light Switch	Press up to turn on beacon light.
18	Rear Wiper/Washer	Rotate CW to turn wipers on. Press button to activate Washer.

TRAVEL CONTROL PANEL

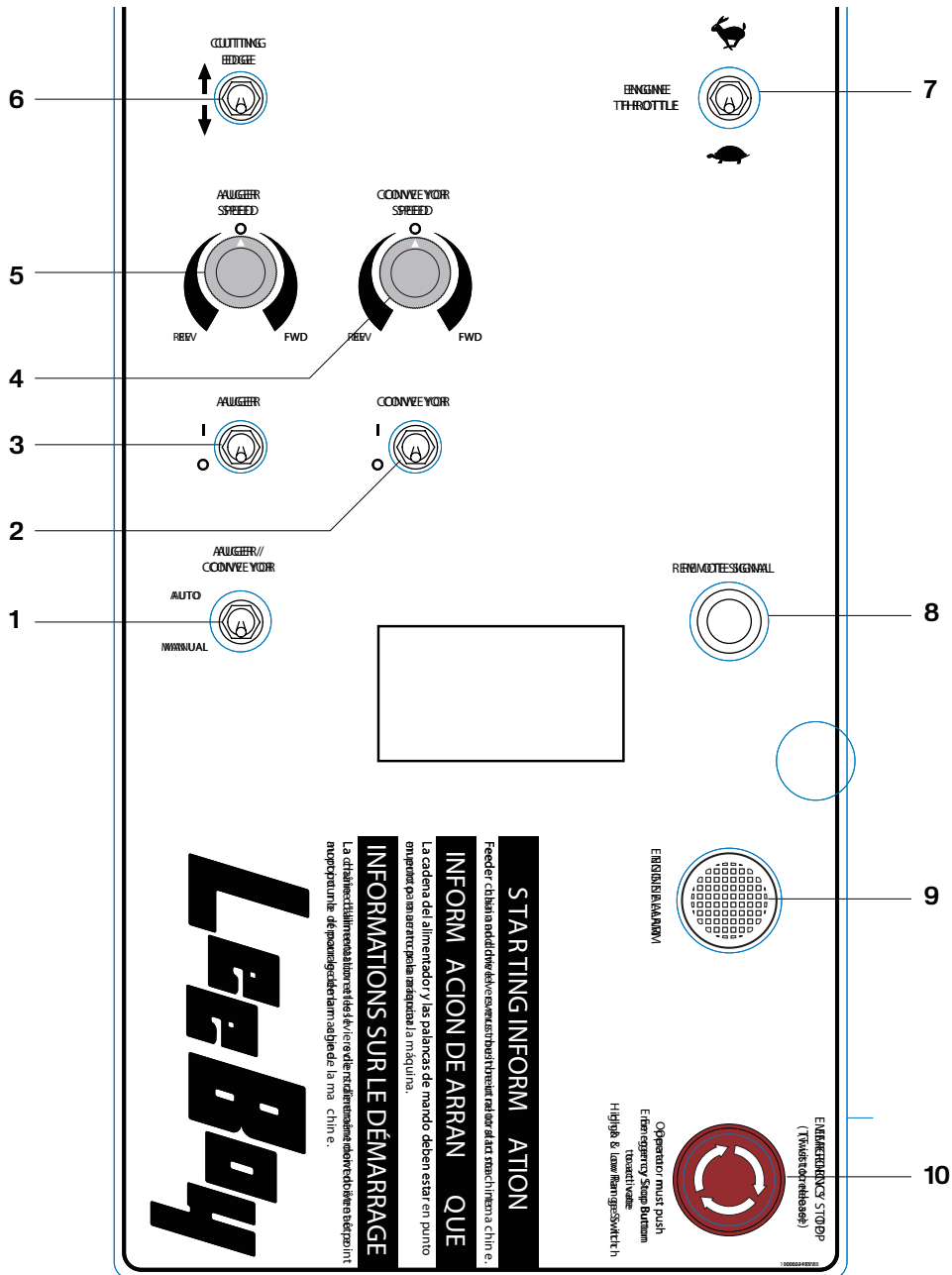

Location of Controls

Figure 5-5

- | | |
|---|-------------------------|
| 1 - Auger / Conveyor Auto / Manual Switch | 6 - Cutting Edge Switch |
| 2 - Conveyor Switch | 7 - Engine Throttle |
| 3 - Auger Switch | 8 - Remote Signal |
| 4 - Conveyor Speed Pot | 9 - Engine Alarm |
| 5 - Auger Speed Pot | 10 - E-STOP Button |

Table 5-5. Main Dash Panel

ITEM NO.	CONTROL NAME	FUNCTION
1	Auger / Conveyor Switch	Push up to start AUTO mode for Auger / Conveyor. Push down to start MANUAL mode for Auger / Conveyor.
2	Conveyor Switch	Push up to turn on Conveyor. Push down to turn off Conveyor.
3	Auger Switch	Push up to turn on Auger. Push down to turn off Auger.
4	Conveyor Speed Pot	Turn clockwise (CW) to increase Forward rotation Auger speed. Turn counter-clockwise (CCW) to increase Reverse rotation Auger speed.
5	Auger Speed Pot	Turn clockwise (CW) to increase Forward rotation Auger speed. Turn counter-clockwise (CCW) to increase Reverse rotation Auger speed.
6	Cutting Edge Switch	Push up to raise Cutting Edge. Push down to lower Cutting Edge.
7	Engine Throttle	Up to Increase. Down to decrease.
8	Remote Signal	Signal light that indicates when Sifter Remote Control (Figure 5-7) is in use.
9	Engine Alarm	Provides audible warning when coolant temperature is too high or if engine oil pressure falls below required limit
10	E-STOP	<p>Depress to deactivate machine. Twist clockwise (CW) to release. This must be released to allow 3000SS Sand Shark with Sand Sifter to function. Pressing the E-STOP will shut off fuel supply to the engine and will stop all hydraulically driven systems. See "Braking" on page 6-4</p> <p>NOTICE The E-STOP remains in a locked down position until it is manually released. The E-STOP remains in a locked down position until it is manually released. Engine will not start with the E-STOP engaged.</p>

TOPCON V CONTROL

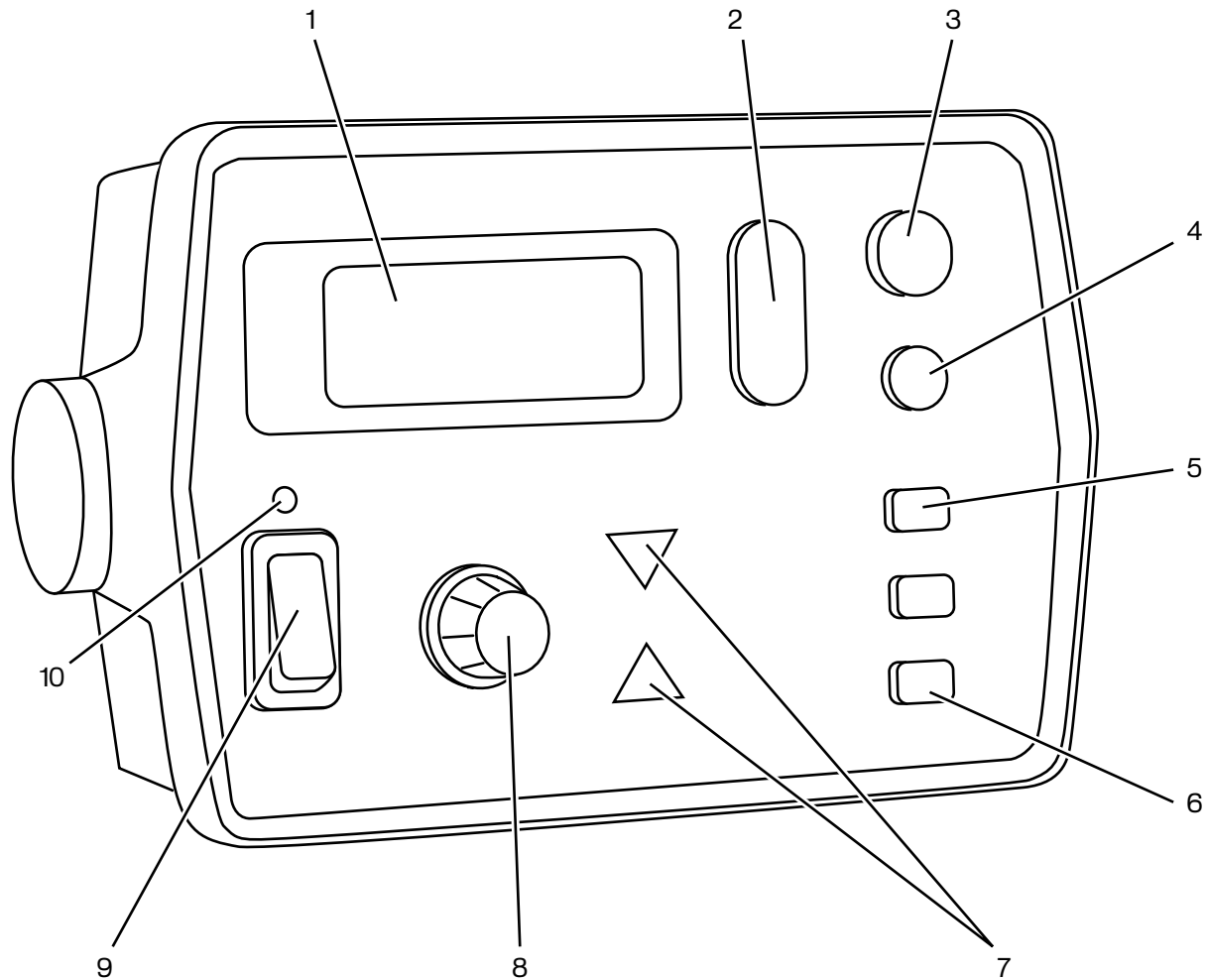

TopCon V Controls

Figure 5-6

- 1 - LCD (Liquid Crystal Display)
- 2 - Jog Switch
- 3 - Auto/Manual Button
- 4 - Survey/Indicate Button
- 5 - Elevation Button

- 6 - Set/Menu Button
- 7 - Grade Adjustment LED
- 8 - Grade Adjustment Knob
- 9 - Power Switch
- 10 - Light Sensor for LCD Display

Table 5-6. TopCon V

ITEM NO.	CONTROL NAME	FUNCTION
1	LCD (Liquid Crystal Display)	The LCD allows the operator to view text and graphic symbols that represent elevation or slope settings that TopCon V is currently maintaining for the Sand Shark
2	Jog Switch	Raises and lower moldboard elevation. <ul style="list-style-type: none"> • To raise moldboard cylinder, push switch up. • To lower moldboard cylinder, push switch down.
3	Auto/Manual Button	<p>Automatic Mode</p> <p>The moldboard lift cylinders are automatically adjusted up or down to maintain proper grade.</p> <p>Press the red button. The red LED will light up showing that the Control Box is in Auto Mode.</p> <p>Manual Mode</p> <p>TopCon V will display grade corrections but the moldboard cylinders will not be adjusted.</p> <p>Press the Red Button. The red LED will NOT be lit, showing that the Box is in Manual Mode.</p>
4	Survey/Indicate Button	<p>Survey</p> <p>Survey is used to quickly “Null Out”, or set the sensor to On-grade.</p> <p>Push button for 1 second until box beeps and green On-Grade Correction Display bar is illuminated.</p> <p>Indicate</p> <p>Indicate Mode allows the operator to continuously monitor the grade or slope setting on the LCD.</p> <p>Continue pressing on the button until there is a second beep. “IND” will be shown in the LCD display. There will be no Grade lights. To exit out of Indicate Mode push either the Survey button or the Auto Button.</p> <p>NOTE: By entering Indicate Function, TopCon V will be taken out of Automatic Mode.</p>
5	Slope/Elevation Button	<p>The Slope/Elevation button is used to select TopCon V for slope or elevation control.</p> <p>Slope Mode - Press the button and the yellow LED next to the Cross Slope Symbol will illuminate.</p> <p>Elevation Mode - Press the button again and green LED next to the Elevation Symbol will illuminate.</p>

TopCon V Control (continued)

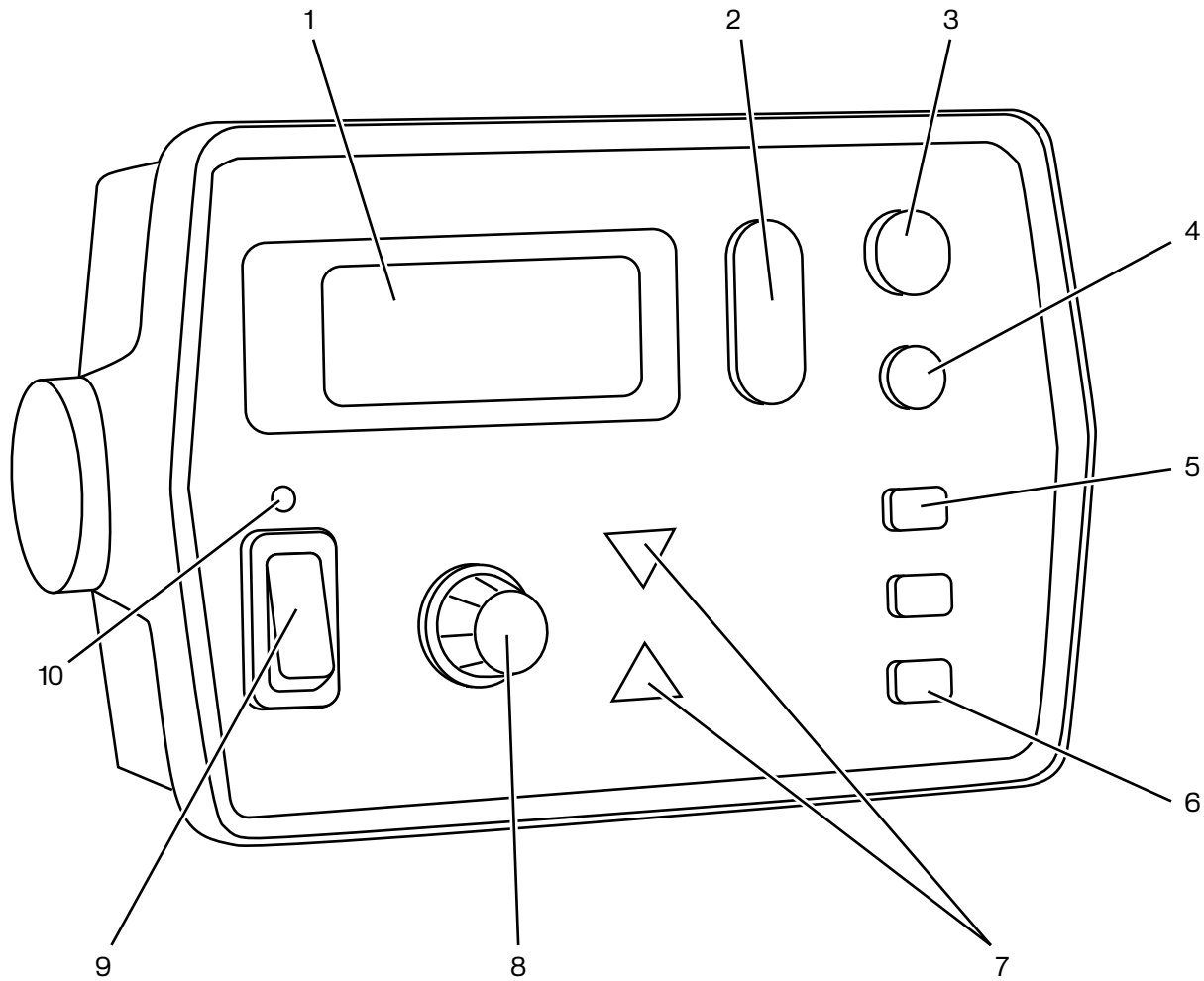

TopCon V Controls

Figure 5-6

- 1 - LCD (Liquid Crystal Display)
- 2 - Jog Switch
- 3 - Auto/Manual Button
- 4 - Survey/Indicate Button
- 5 - Slope/Elevation Button

- 6 - Set/Menu Button
- 7 - Grade Adjustment LED
- 8 - Grade Adjustment Knob
- 9 - Power Switch
- 10 - Light Sensor for LCD Display

Table 5-6. TopCon V

ITEM NO.	CONTROL NAME	FUNCTION
6	Set/Menu Button	<p>The Set/Menu button has two functions.</p> <p>Set Mode</p> <p>Set is used to change the reference number viewed on the display to a desired value.</p> <p>Press and hold the Set/Menu button and dial in desired value using the Grade Adjustment Knob.</p> <p>Both the Grade Correction Indicator Lights and the Double Arrows will be lit.</p> <p>Release the Set/Menu Button and the value will be saved.</p> <p>NOTE: Using Set will not change the existing moldboard cutting depth, it only changes the reference number viewed on the display.</p> <p>Menu Mode</p> <p>(See Accessing System Five™ Performance Settings)</p>
7	Grade Adjustment LED	LED light indicates status of slope and grade based on distance feedback from sonic sensors.
8	Grade Adjustment Knob	<p>This knob is used to make measured adjustments to the Cross Slope or Elevation settings and allows the operator to cycle through the menu options.</p> <ul style="list-style-type: none"> • Knob adjusts the grade height for when Elevation Control is selected. • Knob adjusts the percentage of slope when Cross Slope Control is selected. <p>Grade Adjustment Direction Arrows</p> <p>These red arrows light up around the Grade Adjustment Knob to indicate the direction the knob should be rotated to reach On Grade.</p> <p>A Rotate the knob counterclockwise to reach grade.</p> <p>B Rotate the knob clock wise to reach grade.</p>
9	Power Switch	<p>The Power Switch for TopCon V.</p> <ul style="list-style-type: none"> • Press “I” on the switch to turn the Box on. • Press “O” on the switch to turn the Box off.
10	Light Sensor for LCD Display	Automatically adjusts the brightness of the LED display for better visibility

SIFTER REMOTE CONTROL

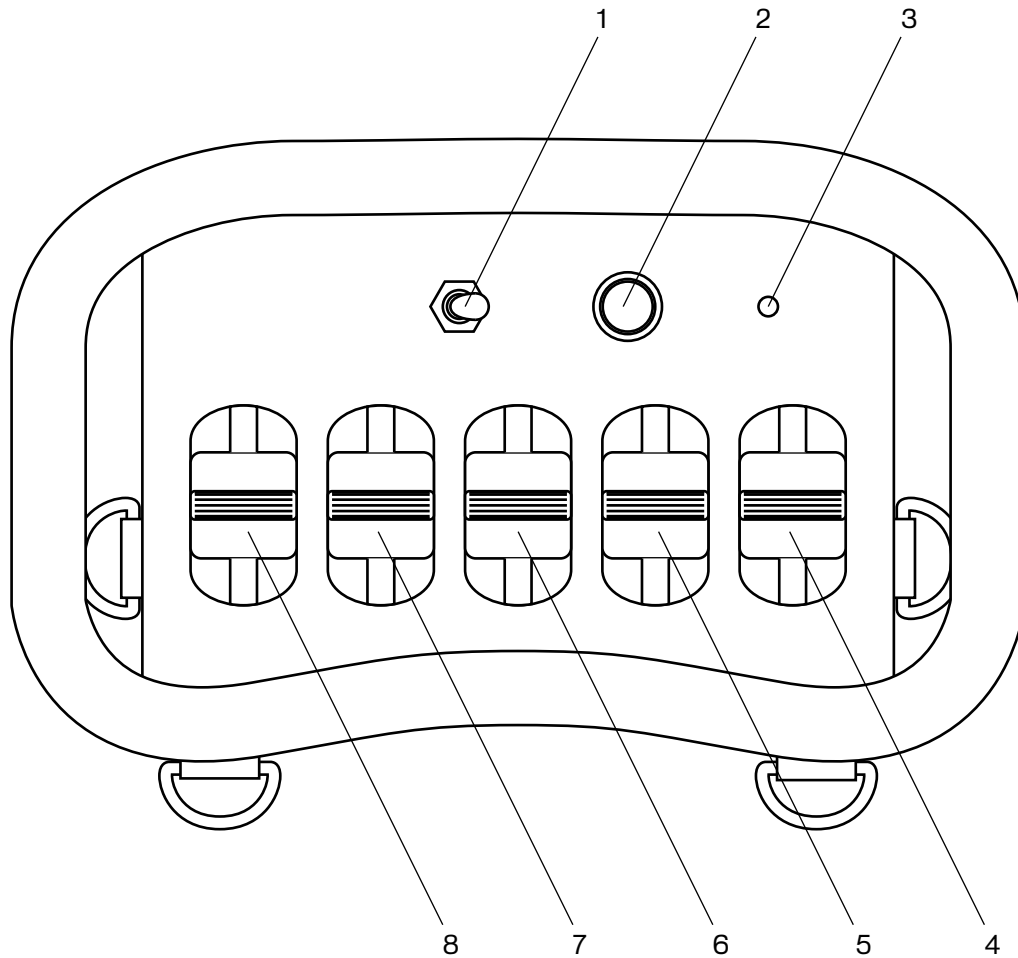

Sifter Remote Control

Figure 5-7

- | | |
|--------------------------------------|-------------------------------------|
| 1 - Remote Power ON / OFF Switch | 5 - Hopper DUMP / RETURN Switch |
| 2 - Horn Button | 6 - Hitch UP / DOWN Switch |
| 3 - Status Light | 7 - Hopper LIFT / LOWER Switch |
| 4 - Right Box Blade UP / DOWN Switch | 8 - Left Box Blade UP / DOWN Switch |

Table 5-7. Sifter Remote Control

ITEM NO.	CONTROL NAME	FUNCTION
1	Remote Power Switch	Press to right to turn ON remote functions. Press to left to turn OFF remote.
2	Horn Button	Press to make Sand Shark horn sound.
3	Status Light	Blue LED indicates when remote is communicating with receiver unit on Sand Shark.
4	Right Box Blade Switch	Press up to RAISE Right Box Blade. Press down to LOWER Right Box Blade.
5	Hopper Dump Switch	Press up to DUMP (tilt down) hopper contents. Press down to RETURN (tilt up) hopper contents.
6	Hitch Switch	Press up to RAISE hitch. Press down to LOWER hitch.
7	Hopper Lift Switch	Press up to LIFT Hopper. Press down to LOWER Hopper.
8	Left Box Blade Switch	Press up to RAISE Left Box Blade. Press down to LOWER Left Box Blade.

NOTES



Section 6 OPERATION

	Page
Operation	6-1
Introduction	6-2
Inspection Before Initial Start-Up.	6-2
Daily Inspection	6-3
Sand Shark Operation	6-3
Start-Up Procedure	6-3
Braking	6-4
Parking Brake	6-4
Selecting High Or Low Speed	6-4
Forward And Reverse	6-4
Increasing Travel Speed	6-5
Feeder Chain	6-5
Discharge Conveyor Belt	6-5
Conveyor Lifting And Lowering	6-5
Stopping The Engine.	6-5
Moldboard	6-5
Sifting - Option 1	6-6
Sifting - Option 2.	6-6
Transporting.	6-7
Sifter Operation	6-7
Feeding And Discharging Connections.	6-7
Basic Feed Criteria	6-7
Sifter System	6-8
Sifter Operating	6-9

INTRODUCTION

Daily inspection and servicing at required intervals is necessary for the safe operation and maximum service life of the 3000SS Sand Shark with Sand Sifter and its components.

CAUTION Only qualified persons should service the 3000SS Sand Shark with Sand Sifter. Contact your authorized LeeBoy Dealer for necessary training.

WARNING Do not smoke when performing inspections or servicing unit. Flammable liquids are present.

Before operating the 3000SS Sand Shark with Sand Sifter, you must read the following safety information and review **Safety** in Section 2.

Daily inspection and servicing at required intervals is necessary for the safe operation and maximum service life of the 3000SS Sand Shark with Sand Sifter and its components.

WARNING Do not smoke when performing inspections or servicing unit. Flammable liquids are present.

DANGER Operation Hazard! Never allow anyone who is not properly trained to operate this Sand Shark. Only authorized personnel who are properly trained in the operation of the Sand Shark can operate the 3000SS Sand Shark with Sand Sifter.

DANGER Operation Hazard! Never leave machine unattended with keys in ignition. Operator must be seated in operator's seat at all times when keys are in ignition. Before leaving machine operator must return joysticks to neutral position, move RUN/STOP switch to STOP position, and remove engine ignition keys.

DANGER Operation Hazard! Do not operate a Sand Shark that requires repairs or scheduled maintenance. Put an information tag on the instrument panel that says "DO NOT OPERATE." Remove the key from the ignition switch. Repair all damage at once and perform routine maintenance. Minor damage can result in major system failure.

Inspection Before Initial Start-Up

The following inspection by the operator is essential. This inspection should be performed on a daily basis. Procedures for performing the inspections are described in the this manual, (see **Maintenance** in Section 7).

Visually inspect the unit for familiarization and to check its general condition. Continue with a check of special systems and components.

Table 6-1. Operator Inspection

INSPECT	PROCEDURE
Hydraulic Tank	Check the tank on the right side of cab for oil level and for any leaks. Use EAL 224H All Weather Hydraulic Oil.
Fuel Tank	Check for adequate fuel supply. Tank is located on left side of the cab.
Double Pump Drive	Check the oil level at the plug. Oil should flow out at proper level (85W90).
Engine Crankcase	Check oil level with dipstick
Radiator	Check coolant level
Battery	Make sure that all cables are tight and clean. Check for corrosion on the battery terminals.
Air Cleaner	Check the air filter element and hose connections. Air cleaner has both a primary and secondary filter.
Planetary	Check oil level. (Drain and replace after the first 50 hours).
Drain Plugs	Make sure plugs are in and tight
Engine Belt	Check for proper tension of belt
Grease Fittings	Ensure fittings are greased and in good working order

Daily Inspection

Check the following items daily to maintain the life and reduce the maintenance cost of your 3000SS Sand Shark with Sand Sifter.

Table 6-2. Daily Inspection

INSPECT	PROCEDURE
Hydraulic Oil Level	Observe the gauge attached to the side of the hydraulic tank. Use EAL 224H All Weather Hydraulic Oil.
Hydraulic Cylinders	Inspect all cylinders to ensure there are no leaks as a result of sand abrasion.
Feeder Bushings (lube daily)	Lubricate with specified grease (see Maintenance Adjustments in Section 7)
Fuel Supply	Check the fuel gauge on the gauge panel
Engine Oil Level	Measure on right side of the engine. Open the access door to access the dipstick. Pull out the dipstick and make sure the oil is clean and falls between the two marks on the dipstick (see Engine Maintenance in Section 7).
Coolant Level	(see Radiator Check in Section 7) ⚠ WARNING Never remove radiator cap when hot. Serious burns can result from the hot liquid.
Air Cleaner Indicator	Located on top of the cleaner. When indicator is "RED", the air filters need to be replaced. Indicator can be reset by pressing the button on top of the indicator.
Engine Belt Tension	Must be checked for wear and proper tension (see Engine Drive Belt in Section 7).
Conveyor Belt	Must be centered (see Conveyor Belt Centering in Section 7). Check belt for proper alignment and wear (see Conveyor Belt in Section 7).

SAND SHARK OPERATION

Start-Up Procedure

NOTE: Refer to **Table 5-1. Control Panels** for additional control information.

NOTE: The engine will not start unless the CONVEYOR SPEED POT, AUGER SPEED POT (**Figure 5-5,4,5**), and Forward/Reverse Direction Control joysticks (**Figure 5-2,3**) are all in the Neutral position.

1. Check that CONVEYOR SPEED POT and AUGER SPEED POT are in the Neutral (N) position.
2. Check that E-STOP (**Figure 5-5,10**) is engaged (pushed down).
3. Check that Forward/Reverse Direction control joysticks (**Figure 5-2,3**) are in Neutral (N) position.
4. Set the MAIN CONVEYOR LIFT and DEFLECTOR switches to the "Center" position.

⚠ WARNING If engine does not start, do not keep Ignition Key in Start position for more than 30 seconds. Release key and wait at least 2 minutes before trying to starting again.

5. Turn the "Ignition" key switch (**Figure 5-4,14**) clockwise to the start position.
6. When engine starts, adjust throttle for a reading of 1500 RPM as shown on the RPM gauge (**Figure 5-4,2**). (Be careful not to over rev engine when warming up.)

NOTE: (Low Idle 950, High Idle 2350)

Braking

Braking is accomplished by pushing the Forward/Reverse Direction Control joysticks (Figure 5-2,3) back to Neutral to slow down travel speed.

WARNING Sudden deceleration could cause operator to be thrown from seat causing personal injury. Operator must secure seat belt while operating of the 3000SS Sand Shark.

In emergency situations the fail-safe brake can be applied by pushing down on the E-STOP (parking brake), or switch to the “Stop” position. Once “Stop” mode has been engaged, it is recommended to adjust the Forward/Reverse Direction Control joysticks to the neutral position to prevent unintended motion once the machine is put back into “Run” mode. Failure to adjust the Forward/Reverse Direction Control joysticks to the neutral position will cause the machine to resume it’s previous travel speed once “Run” mode is re-activated. Pressing the E-STOP will disable all machine functionality and it will be necessary to release the E-STOP before restarting the machine. (Figure 5-5,10).

Parking Brake

The 3000SS Sand Shark with Sand Sifter is equipped with an E-STOP (Figure 5-5,10) located to the right of the operator. This push-button brake should only be used for emergency stopping or after being stopped for parking. This push-button, when engaged, will hold the vehicle from moving. To engage the brake, press down on the E-STOP.

NOTE: To release the brake, turn the button clockwise and pull the push-button up. E-STOP must be released to have Sand Shark and Sifter functionality.

Selecting High Or Low Speed

WARNING When using the High/Low toggle switch to change from low to high speed, or high to low speed, the vehicle must be stopped and the Forward/Reverse Direction Control joysticks (Figure 5-2,3) set to the Neutral position.

The High/Low Gear Shift toggle switch (Figure 5-2,2), is located below the Joysticks on the left operator control panel. It controls the low and high ranges on the 2-speed motor.

NOTE: Do not operate in high gear. High gear is for traveling. only.

Forward And Reverse

WARNING Rapid counter-rotation in either direction, clockwise or counterclockwise could result in operator being thrown from machine resulting in personal injury or death. Counter-rotation is defined as either one joystick in extreme forward position and opposite joystick in extreme rear position, or steering wheel is in extreme right or left turn position while machine is in gear and moving forward or reverse. Make only slow adjustments to joysticks or steering wheel to turn machine.

The 3000SS Sand Shark with Sand Sifter is equipped with a Forward/Reverse variable speed hydraulic motor and a two-speed motor. The Forward/Reverse Direction Control joysticks (Figure 5-2,3), located to the left of the operator, control the speed of the hydraulic pump. This pump will control the speed of travel either in forward or reverse.

A toggle switch located to the left of the operator seat selects either high or low speed in the two-speed motor. Braking is accomplished by returning the Forward/Reverse Direction Control joysticks (Figure 5-2,3) to Neutral (center position). As the joystick is moved toward Neutral the speed of travel will slow allowing the operator to choose the speed desired. In case of an emergency, the E-STOP (Figure 5-5,10) may also be used to stop the machine.

WARNING Sudden deceleration could cause operator to be thrown from seat causing personal injury. Operator must secure seat belt while operating of the 3000SS Sand Shark.

Increasing Travel Speed

The travel speed is determined by the setting of the Throttle switch and the position of the HIGH/LOW speed switch. The TWO SPEED switch is usually set to the High-speed position for transporting the machine a long distance.

Feeder Chain

The auger and feeder system picks up the material and transfers it on the discharge conveyor belt. The AUGER SPEED pot (Figure 5-5,5), on the right side of operator's station determines the speed of the auger chain. Turning the pot back to neutral slows and stops the feeder chain. Rotate counter-clockwise (CCW) from center to run feeder chain in reverse.

Discharge Conveyor Belt

WARNING Never use hands to free a clogged belt. Keep clothing and hands away from moving belt.

The Discharge CONVEYOR SPEED pot (Figure 5-5,4) is the outer pot to the right of the operator. When the pot is turned clockwise (CW), the belt will move to discharge material to the sifter or truck. The belt speed is controlled by how far the pot is turned from Neutral and the engine RPM. By turning the pot counter-clockwise (CCW), the belt will run in reverse. Running the belt in reverse should only be done to unclog a belt. If the pot is set at 0 (neutral position) the conveyor belt will not turn.

Conveyor Lifting And Lowering

WARNING If the conveyor is being raised to perform work under the conveyor, be sure to insert the safety pins (Figure 6-1), into the cylinders.

Conveyor should be in the down position for transporting.

Lifting and lowering the discharge conveyor is done by the CONVEYOR LIFT switch (Figure 5-4,6) on the console to the right of the operator's station. This is a three position toggle switch with the center position Off.

When the switch is set to the Up position, the conveyor is raised. When the switch is set to the Down position, the conveyor is lowered.

The conveyor must be raised to allow a truck or sifter to be positioned under the conveyor. Lower the conveyor when transporting. Always pin conveyor in position when operating the Sand Shark.

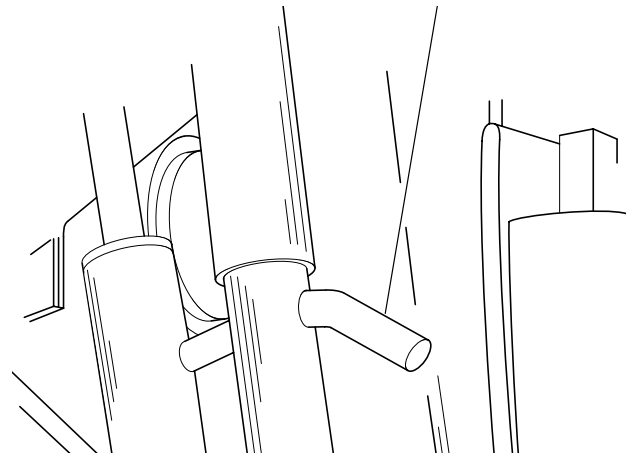

Conveyor Safety Pins

Figure 6-1

Stopping The Engine

1. Throttle back to idle by moving the throttle switch to the minimum RPM (turtle) position.
2. Move the Forward/Reverse Direction Control joysticks (Figure 5-2,3) to the Neutral position.
3. Turn Ignition key on instrument panel counterclockwise (CCW) to the OFF position and remove key.

Moldboard

(Machine Setup Moldboard & Feeder)

It is important to set up the 3000SS before operating to ensure that the 3000SS can be operated as designed. The set up should be checked daily to ensure that there is no interference between moldboard and feeder.

1. Place machine on a flat surface.
2. Raise the rear of the main conveyor into the work position and pin conveyor.
3. Lower the cutting edge to the ground so that cutting edge is flat on the ground, (Do not Float), (Figure 5-5,6).
4. Adjust feeder height off the transition plate to 1 1/2" to 2" using nut 1 in Figure 6-2.

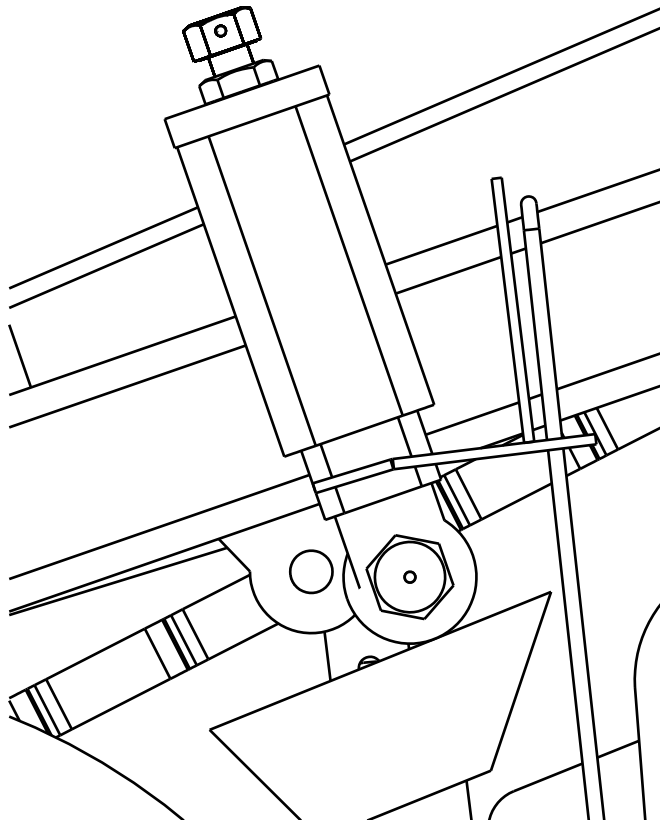

Roller Assembly Adjustment

Figure 6-2

5. Align position indicators in **Figure 6-3**.

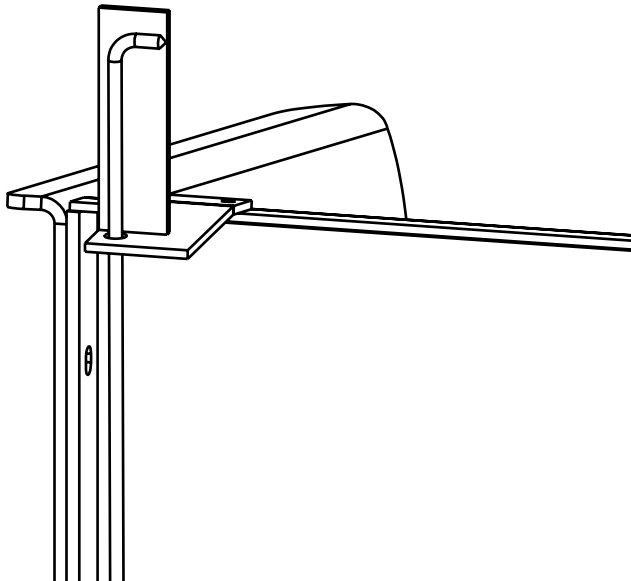

Cutting Edge Position Indicator

Figure 6-3

Sifting - Option 1

1. Raise the main conveyor. Install locking pins at required working height.
2. Raise the sifter height via the hitch cylinder.
3. Set desired deflector position (typically all the way down).
4. Raise the Sand Shark RPM to full throttle and ensure that the machine is operating in low gear.
5. Turn on the sifter.
6. Set the main conveyor speed to desired value.
7. Turn on paddles and set them to the desired speed.
8. Ensure that the cutting blade is in the center position.
9. Turn on TopCon V system.
10. Make sure Top Con is operating in "grade" mode.
11. Slowly move forward while adjusting the cutting depth to the desired level.

NOTE: Cutting too deep, too quickly can make it difficult to level the system once desired depth is achieved.

12. Once at desired depth, lower the depth wheel so that the tire is resting on the uncut sand.
13. Ensure that the Top Con sonic tracker is tracking the depth wheel arm.
14. Press the "survey" button.
15. At this point the machine should be on grade, if not, adjust depth with the fine control knob until machine is on grade.
16. Once the machine is on grade, press the "auto" button.
17. Continue to move forward at a rate that does not overload the sifter.
18. Adjustment to cutting depth can be made utilizing the fine control knob.
19. If the machine begins to track with a "cork-screw", adjust the cutting edge to return to level cutting.

Sifting - Option 2

1. Follow the first 15 steps of Sifting Option 1 but continue to operate the machine in manual mode.

Transporting

When transporting the 3000SS Sand Shark on a trailer, the vehicle should be large enough to safely handle the size and weight of the Sand Shark in all driving situations.

1. Push the Run/Stop switch to off position. (Figure 5-5,10) .
2. Use enough chains to secure the Sand Shark to make sure that it will not move while transporting. Use the factory tie downs (Figure 6-4).

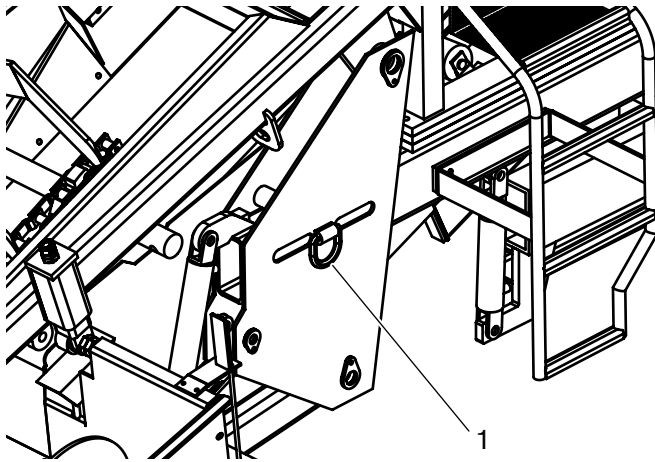

Typical D Ring For Tie Down

Figure 6-4

1 - Typical D Ring Tie Down

SIFTER OPERATION

Feeding And Discharging Connections

The Sifter is equipped with feed wear plates fabricated from heavy steel to receive material fed from the Sand Shark. These feed wear plates absorb the initial force of falling material thereby preventing wear to the remainder of the unit.

The correct feeding to the Sifter is very important to obtain maximum performance (see **Sifter System** in Section 6).

Basic Feed Criteria

NOTE: To make use of the full potential of your vibrating screen, it is to the operator's advantage to limit the feed volume flow rate to a value where the greatest amount of material is in direct contact with the vibrating screens without allowing unsifted material to pass into the hopper.

1. Material is fed to the center of the feed plate at a rate moderate enough to avoid spilling over the sides.
2. Material should not strike the top screen directly. .

NOTE: A heavy feed can force "near-size" particles to lodge into the openings of the screen resulting in reduced efficiency.

3. Flow of material should be full width of the screen.
4. Material depth on the screen should NOT be too great as to allow the fine material to "ride over" into the hopper along with coarse material.

NOTE: The screen openings are determined by the type of material to be sifted. Machine travel speed while cutting should be determined based on size of debris to be removed.

Operation

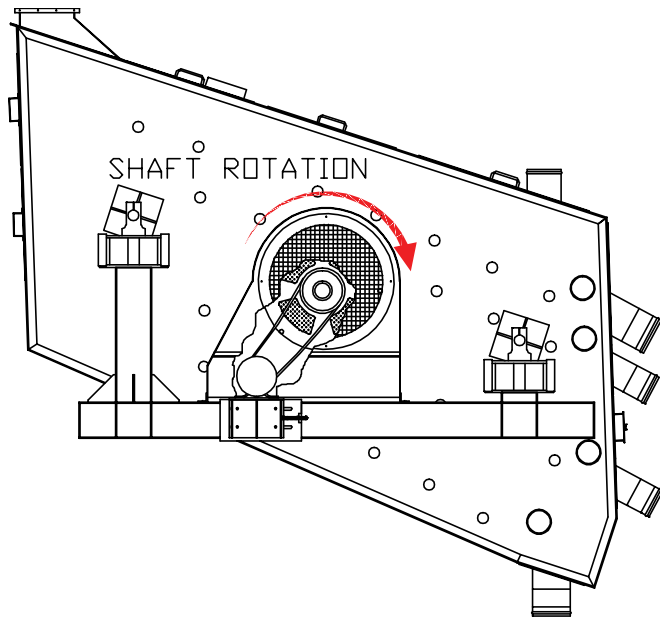

Conveying Mode

Figure 6-5

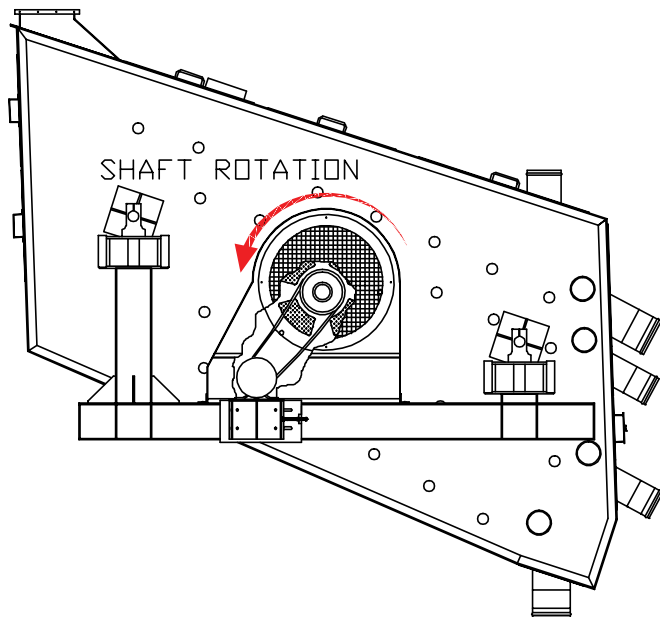

Retaining Mode

Figure 6-6

Sifter System

To start sifter vibration system, press Sifter switch (Figure 5-4,12) up.

To stop sifter vibration system, press Sifter switch (Figure 5-4,12) down.

NOTE: The feed material should be fed onto feed plate in a direction parallel to the side of the sifter. Oblique material flows will increase the wear rate of the sifter.

NOTE: On no account should a column of material be allowed to form above feed plate, or material be allowed to drop from any height greater than 12 in (305mm) onto feed plate or screen panels.

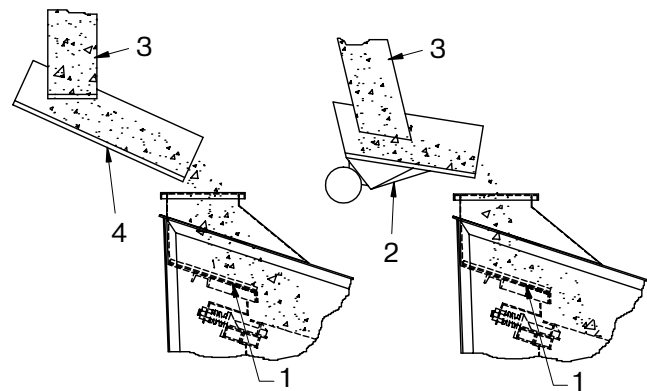
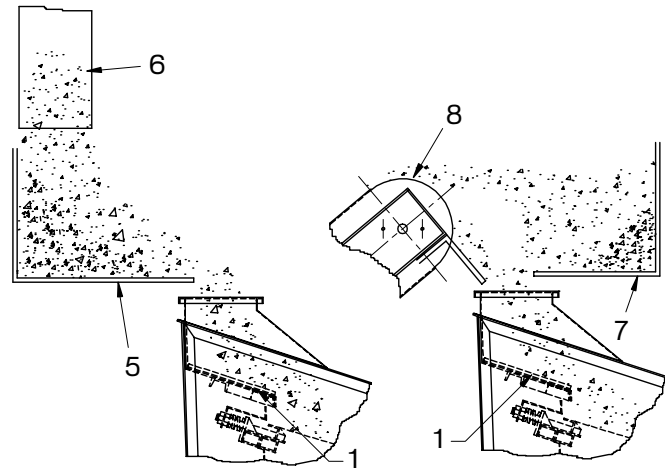

Correct Feed Arrangements

Figure 6-7

- 1 - Feed Plate
- 2 - Vibrating Feeder
- 3 - From Conveyor or Hopper
- 4 - Angled Chute (Variable)
- 5 - Dirt Box Feed
- 6 - From Conveyor
- 7 - 2-Way Dirt Box Feed
- 8 - Conveyor Head Drum

Sifter Operating

Before operating the Sifter unit supplied with the 3000SS Sand Shark, be sure the unit is connected properly (see **Inspection Before Initial Start-Up** in Section 6).

WARNING Do NOT attempt to disconnect or perform maintenance on the sifter unit while it is running.

NOTE: Sand Shark cab operations can be controlled from inside the tractor cab (Figure 5-4) or outside with the supplied remote control (Figure 5-7).

1. Press the Sifter System Switch UP to start the sifter vibration system. (Figure 5-4,12)
2. Position the Box Blade at the required height using the Left Box Blade Switch (Figure 5-4,5) and Right Box Blade Switch (Figure 5-4,4).

WARNING The operator must ensure all personnel are clear of the sifter and box blade before moving and operating the unit.

3. Raise or Lower the hitch as needed using the Hitch Switch (Figure 5-4,10) to keep the sifter unit close to level for increased efficiency.

NOTE: The hitch receiver on the Sand Shark can also be adjusted up and down for more height adjustment.

4. Adjust the material feed rate so there is optimal coverage across most of the vibration screen (see **Basic Feed Criteria** in Section 6).
5. Press the Sifter System Switch DOWN to stop the sifter vibration system. (Figure 5-4,12)

Leveling Sifted Material

After the material is sifted, it is dropped out the bottom of the sifter unit where it will be leveled, or “screeded”. There are three (3) main components used to screed the sifted material.

1. Under the sifter in front of the axles are deflector plates on each side that channel the material toward the center of the sifter. These plates are NOT adjustable.
2. Located between the wheels is an adjustable strike-off plate. The strike-off plate is accessible from the front of the sifter and can be adjusted up or down by removing the attaching bolts and re-attaching using a different set of holes in the frame.

3. The box blade at the rear of the sifter unit is used to screed the sifted material to its final height. Each side of the box blade is adjusted up and down independently to better match the slope of the ground. The box blade height can be controlled from inside the Sand Shark cab (Figure 5-4) or outside with the supplied remote control (Figure 5-7).

Dumping

There is a hopper at the rear of the sifter unit between the vibration screen and the box blade to catch the coarse material. When the hopper is full, follow these steps to empty the hopper.

WARNING Failure to follow these steps exactly will result in damage to the machine and may cause injury to any persons in close proximity.

WARNING All personnel performing this operation MUST be familiar with the safety requirements and hazardous areas of the sifter unit.

1. Turn the sifter vibration screen OFF using the Sifter System Switch. (Figure 5-4,12)
2. Lower both sides of the box blade until they touch the ground using the Box Blade Left and Box Blade Right switches. (Figure 5-4,4,5)

NOTICE Failure to keep the blade clear of the hopper can result in machine damage.

3. Raise the hopper to its highest position using the Hopper Lift/Lower switch (Figure 5-4,8).
4. Press the Hopper Dump / Return switch UP to dump the contents then press the switch down to return the hopper to its upright position.

NOTE: For complete removal of material, this step may have to be repeated several times (Figure 5-4,7). The switch can also be jogged to “shake” the hopper.

5. Once the material has been dumped, lower the hopper using the Hopper Lift / Lower switch (Figure 5-4,8)
6. After the hopper is returned to its original position, start the sifter vibration screen and return the box blade to its operating height.

NOTE: Additional information regarding the sifter unit is available in the manufacturers supplied manual.

NOTES



Section 7 MAINTENANCE

	Page
Maintenance	7-1
Routine Maintenance.	7-3
General Information	7-3
Maintenance Schedule	7-3
10 Hour or Daily Routine Maintenance	7-3
50 Hour Routine Maintenance	7-4
250 Hour or Quarterly Routine Maintenance	7-4
500 Hour or Semi-Annual Routine Maintenance	7-4
Maintenance Check Procedures	7-5
Radiator Check	7-5
Engine Air Filter	7-5
Engine Maintenance	7-6
Fuel System	7-7
Hydraulic System	7-8
Sifter Tire Pressure	7-10
Battery Servicing.	7-10
Machine Lubrication	7-12
Lubrication Points	7-12
Maintenance Adjustments	7-14
Conveyor Belt Centering.	7-14
Chains.	7-15
Moldboard Cutting Edge	7-15
Conveyor Paddle Blade	7-15
Engine Drive Belt	7-16
Charge Filter.	7-16
Hydraulic Cylinder Replacement	7-16

Conveyor Head Pulley Bearing	7-17
Muffler	7-17
Radiator Hoses And Radiator	7-18
Safety Label Installation	7-18
Track and Sifter	7-19
Change Hub Oil	7-19
Track Adjustment	7-19
Wear Charts	7-19
Lubrication.	7-21
Sifter Bearing Housing Replacement.	7-21
Bearing Replacement Using Existing Housing	7-22
Counterweights	7-23
Screen Panel Tensioning	7-24
Motor External Wiring	7-24
Spreader Bar	7-24
Screen Removal and Installation	7-25
Installation For Decks With Screens	7-28
Installation For Decks Without Screens	7-28
Fines Pan Installation	7-29
Ball Installation.	7-29

This section gives the necessary procedures for routine and general maintenance on the 3000SS Sand Shark with Sand Sifter.

Follow all the Maintenance Schedules and Maintenance Procedures to maintain the machine in top operating order.

ROUTINE MAINTENANCE

General Information

MAINTENANCE must be a planned program that includes periodic machine inspection and lubrication procedures.

The MAINTENANCE program must be done, based on the machine's "Operating Hours", recorded on the hourmeter, or based on the "Periodic Schedule", which is done at time intervals of weekly, monthly or yearly.

The MAINTENANCE program is divided into two subsections: The Maintenance Schedule and the Maintenance Procedures.

Maintenance Schedule

General Information

The Maintenance Schedule lists the recommended time intervals between machine maintenance inspections and lubrication procedures (see **Lubrication Point Schedule** in Section 7). Table 7-1 gives inspection and lubrication information for the 3000SS Sand Shark with Sand Sifter.

The "Hour" and "Periodic" time periods list most service intervals. The maintenance schedule begins with ten hours, or daily, maintenance intervals and continues through the 1,000 hours, or annual, maintenance schedule intervals.

NOTE: If the machine is operated more than ten hours per day, follow the "Hour" schedule. If the machine is operated less than ten hours per day, follow the "Periodic" schedules, where they apply.

Preventive maintenance on the 3000SS Sand Shark with Sand Sifter will provide years of trouble-free operation.

NOTE: Adjustment can be performed in the field with ordinary hand tools.

Engine preventive maintenance, other than oil, air, and fuel filter changes is not covered in this section. Refer to engine operator's manual for engine service information.

NOTICE

The changing of oil and cleaning of the Sand Shark should only be done in a designated area that can contain the oil and chemicals involved in any maintenance requirement. These by-products should be discarded in accordance with environmental regulations.

CAUTION

Do not substitute fasteners of any kind unless the fasteners are equal in size and grade as original equipment.

NOTE: When performing any routine maintenance such as 10, 100, 250, and 1000 hours, always include previous routine maintenance hours to the higher hourly schedule.

10 Hour or Daily Routine Maintenance

1. Check Engine Oil. Refer to Engine Check Procedures in this section.
2. Check Coolant Level. Refer to Radiator Check Procedures in this section.
3. Check Air Filter Gauge. Refer to Air Filter Check Procedures in this section.
4. Check Hydraulic Oil Level. Refer to Hydraulic Oil Check Procedures in this section.
5. Check Conveyor Belt Alignment. Refer to Conveyor Belt Check Procedures in this section.
6. Check Battery Cables for Wear. Visually check cables and cable connections to battery. Also check battery terminal for corrosion.
7. Check Hydraulic Hoses for Leaks. Visually check all hose connections.

WARNING

Do not use hands on any hydraulic hose, fitting or system component to check the system for possible leaks. Serious injury can result from an oil leak under high pressure. Oil can be injected under the skin by high pressure. Protect the eyes by wearing safety glasses.

8. Clean cylinder rods to ensure no sand is present.

50 Hour Routine Maintenance

1. Grease All Fittings Except Bearings. Refer to Lubrication Procedure in this section (see **Lubrication Points** in Section 7).

250 Hour or Quarterly Routine Maintenance

1. Perform the 250 hour preventive maintenance as described in the engine operator's manual.
2. Check Air Cleaner.

NOTICE Improperly serviced air cleaners wear out engines--FAST! In just a few hours a small amount of dirt will wear out a set of piston rings! Refer to your engine operator's manual for service information. Also, perform any other engine preventive maintenance as described in the engine operator's manual.

3. Check all Decals and Nameplates (**Figure 2-1**). Replace if any are missing or damaged.
4. Check head lamps to ensure secure mounting and good working order.
5. Check Filler Cap, breather caps and grease fittings. Repair or replace if necessary.
6. Check for loose, missing, damaged, or corroded parts. Repair or replace as necessary.
7. Perform any other engine preventive maintenance as described in the engine operator's manual.
8. Check Pump Drive Gear Oil Level. Refer to Pump Drive Check Procedures in this section.
9. Check Planetary Hub Fluid Level. Refer to Planetary Hub Check Procedures in this section.
10. Check Sifter Tire Pressure. 33-36 PSI.
11. Replace Fuel Filters.
12. Replace Hydraulic Oil Filter.

500 Hour or Semi-Annual Routine Maintenance

1. Perform the 500 hour preventive maintenance as described in the engine operator's manual.
2. Drain and Flush the Hydraulic Tank. A drain plug is located on the bottom of the tank for this purpose. The recommended hydraulic oil is Exxon, EAL 224H All Weather Hydraulic Oil (environmentally friendly oil) or equivalent.
3. Change Engine Oil.

NOTE: To ensure complete removal of contaminants in the oil, perform the oil change while engine is warm. After draining used oil, clean and reinstall drain plug and fill crankcase to the full mark with manufacturer's recommended oil. Change oil filter at each oil change (see **Lubricant Specifications** in Section 4).

4. Anytime the Sand Shark has been repainted or the decals have been removed, damaged or can't be read, a new set of decals should be ordered and reinstalled for safe operation.

MAINTENANCE CHECK PROCEDURES

Radiator Check

The radiator fill cap is located behind a small access door marked RADIATOR. To check the radiator or add coolant proceed as follows:

1. Open the access door to access the radiator cap (Figure 7-1).

WARNING Do not remove the radiator cap while the engine is still hot. The radiator is under pressure and the hot water can cause serious injury to all persons around.

2. Remove the cap to check and fill radiator. Remove the cap only when the unit is cool. Coolant level should be visible when looking into radiator cap opening.
3. If coolant level is low, add coolant. Do not overfill.

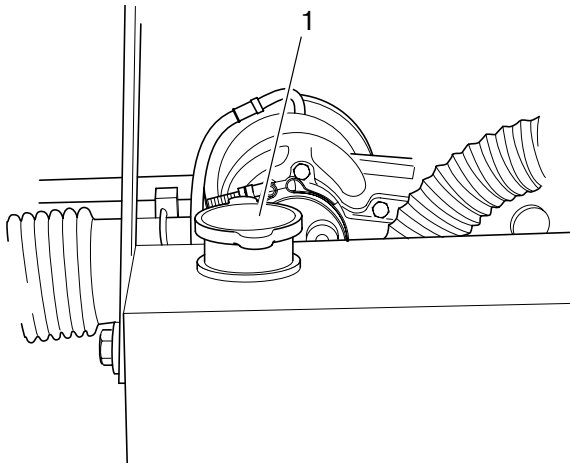

Engine Radiator Fill Cap

Figure 7-1

1 - Fill Cap

NOTICE Do not exceed overflow level mark, this will prevent sucking air in radiator.

Engine Air Filter

The air filter indicator is located on the intake of the air filter (Figure 7-2). As the air filter becomes more clogged, the air pressure increases causing the red flag in the indicator to become visible. When this occurs the air filter must be cleaned or replaced as follows:

1. Remove the wing nut (Figure 7-2), securing the cover on the filter housing then remove the cover.
2. Remove the nut securing the outer filter and remove the outer filter.
3. Remove the nut securing the inner filter and remove the filter.
4. Replace the inner filter and secure with the nut.
5. Replace outer filter and secure with the nut.
6. Install cover and secure with the nut.
7. Reset the filter indicator by pressing down on the button on top of the indicator.

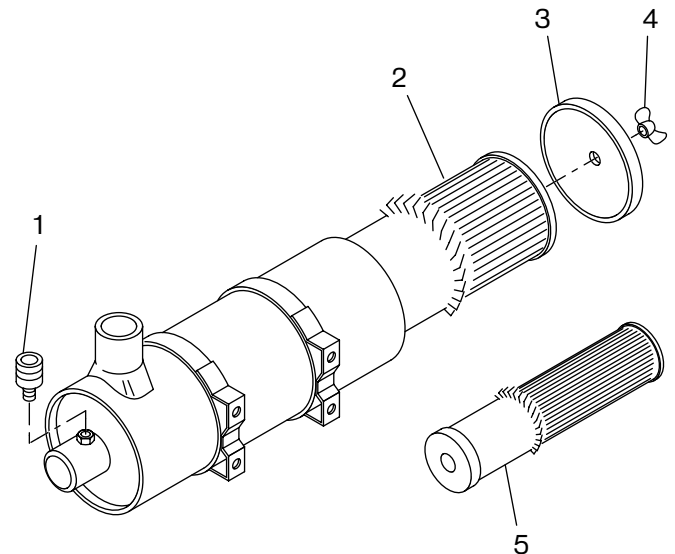

Engine Air Filter

Figure 7-2

1 - Indicator

2 - Outer Filter Primary

3 - Cover

4 - Wingnut

5 - Inner Filter Secondary

Engine Maintenance

General Information

The following engine maintenance information will cover general engine maintenance procedures most often required.

For additional, very specific, engine maintenance information, see the current "OPERATION AND MAINTENANCE MANUAL" -Cummins QSB4.5 Series engine.

Engine Lubrication Oil

Checking the Engine Lubrication Oil Level The engine lubrication oil must be kept at a level above the "ADD" mark, but not above the "FULL" mark, on the engine lubrication oil dipstick (**Figure 7-4**).

To accurately check the engine lubrication oil level, put the machine in a "level" position and stop the engine. Clean the area around the engine lubrication oil dipstick before removing the dipstick from the engine. Wait five minutes after engine shutdown, before removing the dipstick from the engine and checking the oil level.

NOTE: The above procedure will help to remove the possibility of filling the engine with too much lubrication oil, by allowing the oil to return to the oil pan.

⚠ WARNING Stop the engine before checking the engine lubrication oil level. With the engine running, hot oil can be thrown causing serious injury.

To check the engine oil proceed as follows:

1. Lift engine cover located on the right side rear of machine to access the oil dipstick.

NOTE: Oil should be warm when checking oil level.

2. To check the engine oil, pull dipstick out of the engine and check that oil level is near the full mark on the dipstick (**Figure 7-3**). If oil level is low add engine oil.

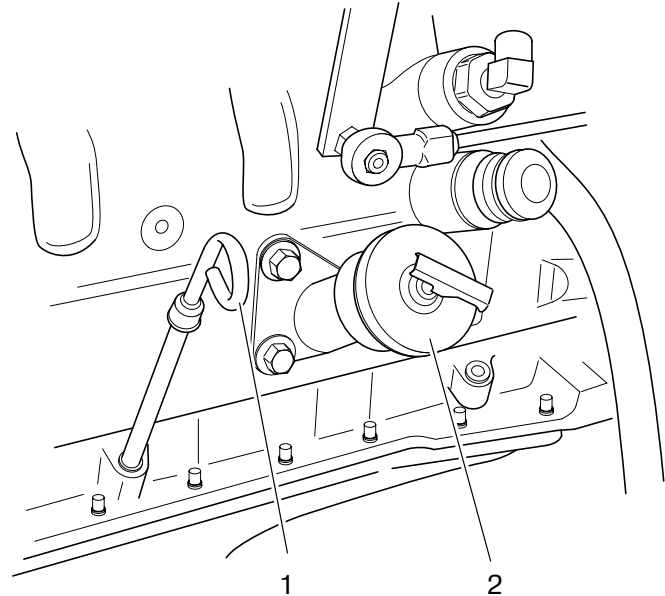

Engine Oil Dipstick And Fill Cap

Figure 7-3

1 - Dipstick

2 - Fill Cap

3. To add oil remove the fill cap located next to the dipstick. Twist to remove cap and twist to install (use 15W40 Motor oil).

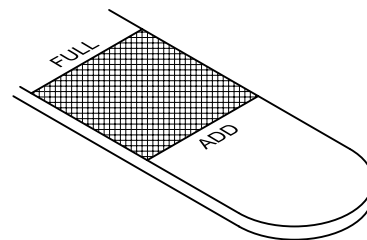

Dipstick

Figure 7-4

Changing the Engine Lubrication Oil

The engine lubrication oil must be changed according to the interval given in the current Cummins Diesel engine "OPERATION AND MAINTENANCE MANUAL".

NOTE: The color of the engine lubrication oil cannot be used as an indication of the need for an engine lubrication oil change. The use of an engine lubrication oil "analysis service" is the only alternate reason for not following the required engine lubrication oil change schedule.

⚠ WARNING Do not change the engine lubrication oil when the engine and lubrication oil are hot. Change when warm only. Hot oil can cause serious injury.

⚠ CAUTION Do not change the engine lubrication oil with the engine "running". Serious engine damage, or failure will occur. Clean the area around the engine lubrication oil dipstick and oil filler cap before removing the dipstick, or oil filler cap.

With the engine "stopped", and the engine lubrication oil "warm", proceed as follows:

1. Clean the area around the engine lubrication oil drain plug located on the engine oil pan.
2. Place a container, having a capacity of 15 quarts (14.2 liters), sufficient to hold the drained oil, directly under the engine lubrication oil drain plug.
3. Carefully remove the engine lubrication oil drain plug.
4. Drain all of the engine lubrication oil into the container.

NOTE: For steel pans, torque the drain plug to 59 ft-lb (80 N.m). For aluminum pans, torque the drain plug 44 ft-lb (60 N.m).

⚠ CAUTION Do not over tighten the drain plug.

5. Clean, install and carefully tighten the lubrication oil drain plug to the correct torque.
6. Be sure that a new oil filter has been installed.
7. Fill the engine to the correct oil level, 11.6 quarts (11 liters), with the correct engine lubrication oil, 15W40.
8. Install the engine lubrication oil dipstick.

⚠ CAUTION Do not start the engine before changing the engine lubrication oil filter. Follow the procedures given in this section and in the current Cummins engine manual.

Changing The Engine Lubrication Oil Filter

NOTE: The engine lubrication oil filter must be changed when the engine lubrication oil is changed.

⚠ WARNING Do not change the engine lubrication oil when the engine and lubrication oil are hot. Change when warm only. Hot oil can cause serious injury.

⚠ CAUTION Do not change the engine lubrication oil filter with the engine running. Serious engine damage, or failure, will occur.

With the engine "stopped" and filled with new engine lubrication oil, proceed as follows:

1. Wipe the area around the engine lubrication oil filter element and its mounting base, with a clean cloth.
2. Place a container under the filter element.
3. Use a filter removal wrench to loosen and remove the filter element by turning it in a counterclockwise direction of rotation. Drain and discard the removed filter element.

NOTE: Be sure the used rubber gasket is removed and discarded with the filter element.

4. Wipe the inside area of the lubrication oil filter head using a clean lint free cloth.
5. Put clean engine lubrication oil on the rubber gasket area of the new filter element. Fill the new filter element with correct, new, and clean oil.
6. Install the new filter element onto the filter head. Carefully tighten the filter element, by hand only.

NOTE: Tighten the filter element as directed on the filter element, by the filter manufacturer.

Fuel System

Fuel Tank

The fuel level is indicated on the gauge panel FUEL gauge and indicates the amount of fuel in the tank. Fill the fuel tank "FULL". Also fill the tank, to "FULL", before the machine is stored for the night to reduce the accumulation of moisture in the tank, from condensation. Fuel capacity is 104 gallons.

WARNING The operator must be off of the machine while fuel is added. No smoking while filling the fuel tank. All fuels for internal combustion engines are flammable. Fill the fuel tank only in a designated area with good ventilation. Have a fire extinguisher available. Never fill the tank near an open flame, or near equipment that can create sparks. Never check fuel level or check for fuel leaks with an open flame.

Engine Fuel Filters

The fuel filter element must be replaced as directed in the current Cummins engine manual. Replace the fuel filter using the following “general” procedure and very specific information given in the current engine manual.

WARNING Diesel fuel is very flammable. Use extra caution.

Do not change the fuel filter with the machine running.

Do not change the fuel filter in an area near an open flame.

Do not smoke while changing the fuel filter.

Do not spill fuel.

1. Stop the engine.
2. Put a container under the fuel filter, before removing the filter element.
3. Wipe the area around the fuel filter element and the element mounting head, using a clean lint free cloth.
4. Use a filter removal wrench to loosen and remove the element, by turning the element in a counterclockwise direction. Drain and discard the removed element.
5. Wipe the inside area of the filter head with a clean “lint free” cloth. Fill the “new” fuel filter element completely full of the correct and clean fuel. Put clean fuel on the element rubber gasket.
6. Install the “new” fuel filter element onto the filter head. Carefully tighten the element by hand only.

CAUTION Tighten the fuel strainer or the fuel filter element as directed on the filter element, by the filter manufacturer. Do not over tighten the fuel filter element onto the filter head.

7. Start the engine and check for any fuel leaks.

WARNING Stop the engine immediately if any fuel leakage is noted. Do not start the engine until the leakage problem is corrected.

Hydraulic System

General Information

The hydraulic oil tank level indicator (**Figure 7-5**) is located on the hydraulic oil tank at the right of machine. Keep the proper level. Check oil level every morning with machine cold and fill as necessary. Machine holds 52 gallons (see **Lubricant Specifications** in Section 4).

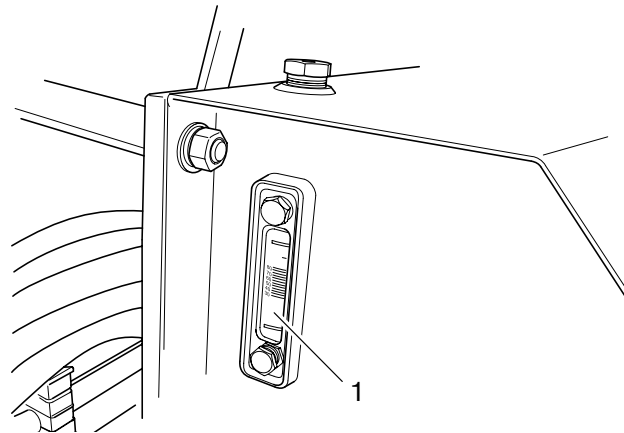

Hydraulic Oil Level Indicator

Figure 7-5

1 - Indicator Glass.

Checking The Hydraulic Oil Level And Adding Hydraulic Oil To The Hydraulic Oil Reservoir

Check the hydraulic reservoir oil level daily by observing the indicator glass located on the end of the hydraulic tank (**Figure 7-6**). Check the oil level when the hydraulic oil is at “normal” operating temperature only.

WARNING Do not loosen, or remove the hydraulic oil reservoir filler cap when the hydraulic oil is hot. Always loosen the filler cap slowly to relieve any pressure in the hydraulic oil reservoir.

Only loosen the filler cap when the oil is at a warm temperature.

If the hydraulic oil level is low on the indicator, the correct filtered hydraulic oil (see **Lubricant Specifications** in Section 4) must be added to the hydraulic oil reservoir.

CAUTION Do not over fill the hydraulic oil reservoir.

Do not use unfiltered hydraulic oil.

The new hydraulic oil must be filtered before it enters the hydraulic oil reservoir. Keep the oil level of the hydraulic oil reservoir at the correct level. An air space is designed into the hydraulic oil reservoir and allows for oil expansion, at warm temperatures.

The hydraulic oil reservoir will have a low pressure in it at system operating temperatures.

Changing The Hydraulic Oil

Changing the hydraulic oil removes the accumulation of dirt, water and mechanical wear particles from the hydraulic oil reservoir and system.

The chemical structure of the hydraulic oil also changes after continuous use in the system and new, clean and filtered oil is a must to help insure further correct operation of the hydraulic system.

CAUTION Hydraulic oil which has oxidized or which contains contamination, of any type, can shorten the expected service life of any, or all, of the components in the hydraulic system.

Use the following procedures to change the hydraulic oil in the hydraulic oil tank (Figure 7-6).

1. Stop the engine. Allow the hydraulic oil to cool, until it is at a warm temperature only. Slowly loosen, and then remove, the hydraulic oil reservoir filler cap (2). Put a CLEAN, lint free cloth over the reservoir fill tube opening and secure in place with tape.

WARNING Do not drain the hydraulic oil from the reservoir when it is hot. Hot hydraulic oil can cause serious injury. Drain at a warm temperature only.

2. Carefully remove the drain plug from the hydraulic tank. Use a drain collection device of sufficient capacity, 52 gallons (196.8 liters), to collect the hydraulic oil. Allow all of the hydraulic oil to drain from the reservoir and into the container.

CAUTION Do not fill the hydraulic oil reservoir with new hydraulic oil until the strainer has been serviced.

3. Install the hydraulic oil reservoir drain plug (Figure 7-6), and tighten securely.
4. Carefully remove the cloth from the hydraulic oil reservoir fill tube opening.

5. Fill the hydraulic oil reservoir with the correct, filtered hydraulic oil (see **Lubricant Specifications** in Section 4).

CAUTION Do not overfill the hydraulic oil reservoir with oil.

6. Check the oil level in the hydraulic oil reservoir, again. Add oil if needed.
7. Install the hydraulic oil reservoir filler cap and tighten securely.
8. Start the engine using the correct procedures. Check the hydraulic system for any leaks.

WARNING Do not use hands on any hydraulic hose, fitting or system component to check the system for possible leaks. Serious injury can result from an oil leak under high pressure. Oil can be injected under the skin by high pressure. Protect the eyes by wearing safety glasses.

CAUTION Stop the engine immediately if any hydraulic leak is noted. Do not start the engine until any problem noted has been corrected.

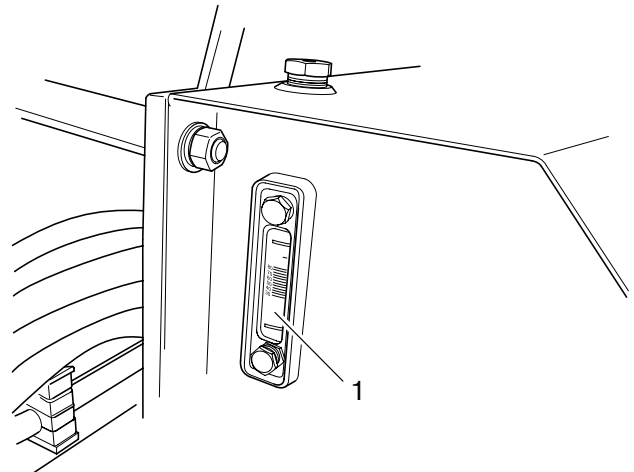

Hydraulic Oil Tank

Figure 7-6

1 - Indicator Glass

Changing The Hydraulic Oil Strainer

The oil strainer is mounted in the oil filler opening under the filler cap.

WARNING Do not remove the hydraulic oil cap from the reservoir when it is hot. Hot hydraulic oil can cause serious injury. Allow hydraulic oil to cool down to a warm temperature.

1. Remove the hydraulic oil filler cap (Figure 7-6).
2. Remove the three screws securing the strainer, then remove the strainer and the gasket.
3. Install a new gasket, aligning the three holes in the gasket with the mounting holes on the reservoir.
4. Install the new strainer, aligning the holes in the strainer with the mounting holes of the gasket and secure the strainer with the three screws.
5. Fill the hydraulic oil reservoir with the correct, filtered hydraulic oil.

CAUTION Do not overfill the hydraulic oil reservoir with oil.

6. Check the oil level in the hydraulic oil reservoir, again. Add oil if needed.
7. Install the hydraulic oil reservoir filler cap onto the reservoir filler neck and tighten securely.

Sifter Tire Pressure

The tires should be maintained at the proper tire pressure (33 to 36 PSI) **Table 4-8. Miscellaneous Specifications**. This should be done once a month. If a tire appears to be low when performing the daily check of the machine, measure the pressure to be sure of proper inflation, (see **Miscellaneous Specifications** in Section 4).

Battery Servicing

WARNING Batteries contain sulfuric acid and normally produce explosive gases that can cause serious injury. Therefore, do not allow flames or sparks to come near the battery.

When charging or working near a battery, always shield your face and protect your eyes. In case of acid contact with skin or eyes, flush immediately with water for a minimum of 15 minutes and get prompt medical attention. If acid is swallowed, call a physician immediately.

The Sand Shark electrical system is a 12-volt negative ground system (Figure 7-7). Keep sparks and flames away from the battery as electrolyte gas is highly flammable.

NOTE: When replacing the battery, discard the old battery properly.

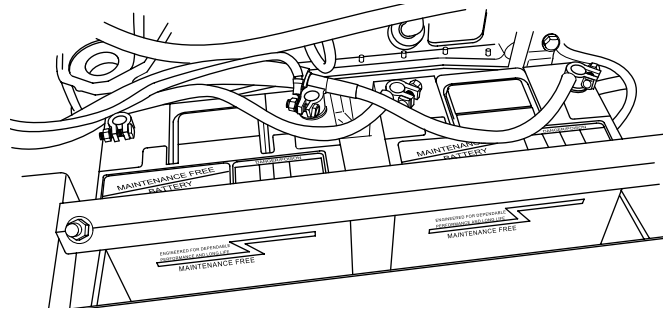

Battery

Figure 7-7

CAUTION When servicing the electrical system or welding on the machine, always turn the Master Disconnect switch to the OFF position to disconnect the ground strap from the battery to prevent damage to the machine electrical system. The Master Disconnect switch is located on the conveyor control panel on the left of the operator.

Before connecting the battery, be sure the Disconnect switch is turned off. Be certain that the terminals and battery posts are thoroughly cleaned and that the battery cable terminals are tight. Dirty or loose connections can create high electrical resistance and permit arcing, which will quickly burn and pit terminals and posts.

NOTE: The electrical system is a negative ground system. Connect the positive (+) cable to the positive (+) post of the battery. Connect the ground cable to the negative (-) post of the battery. It is advisable to disconnect the negative (-) cable first and connect it last. Reversed polarity can damage the electrical system.

Keep the battery clean by washing it off whenever dirt buildup is excessive. If corrosion is present around terminal connections, remove them and wash with ammonia solution or a solution consisting of 1/4 lb. (0.11 kg) baking soda added to one quart of warm water. Make certain the vent caps are tight to prevent solution from entering the cells. After cleaning, pour clean water over the battery and surrounding area to wash the solution away. Check vent cap breather openings to make sure they are open.

Be sure to keep the battery fully charged during cold weather to keep it from freezing. Freezing weather has little affect on a fully charged battery.



WARNING When using a booster battery, do not attach the negative (-) cable from the booster battery to the negative (-) post of the dead battery. A spark could occur and cause an explosion of gases normally present around the battery.

When connecting a booster battery, if necessary for cold weather starting, connect one end of the first jumper cable to the positive (+) terminal of the dead battery and the other end to the positive (+) terminal of the booster battery. Connect one end of the second jumper cable to the negative (-) terminal of the booster battery and the other end to the frame of the machine with the dead battery.

The alternator supplies electrical current for charging the battery and ample electrical power to the electronic controls. The built-in regulator in the alternator controls the voltage output. If for any reason the wires must be disconnected from the alternator, mark them so that they can be reconnected properly. Use the following precautions to prevent damage to the alternator and/or regulator:

1. An alternator is never to be polarized. Never ground any alternator terminals or circuits.
2. Always disconnect the battery before disconnecting or connecting the alternator.

Never disconnect the alternator with it operating. Be certain the wiring is properly connected before connecting the battery.

3. Always connect a booster battery in the proper polarity. Negative (-) to negative (-) and positive (+) to positive (+).
4. Always remove ground cable before welding

LUBRICATION POINTS

Machine Lubrication

Proper lubrication is necessary to maintain the machine at top efficiency (see [Table 7-1. Lubrication Point Schedule](#)).

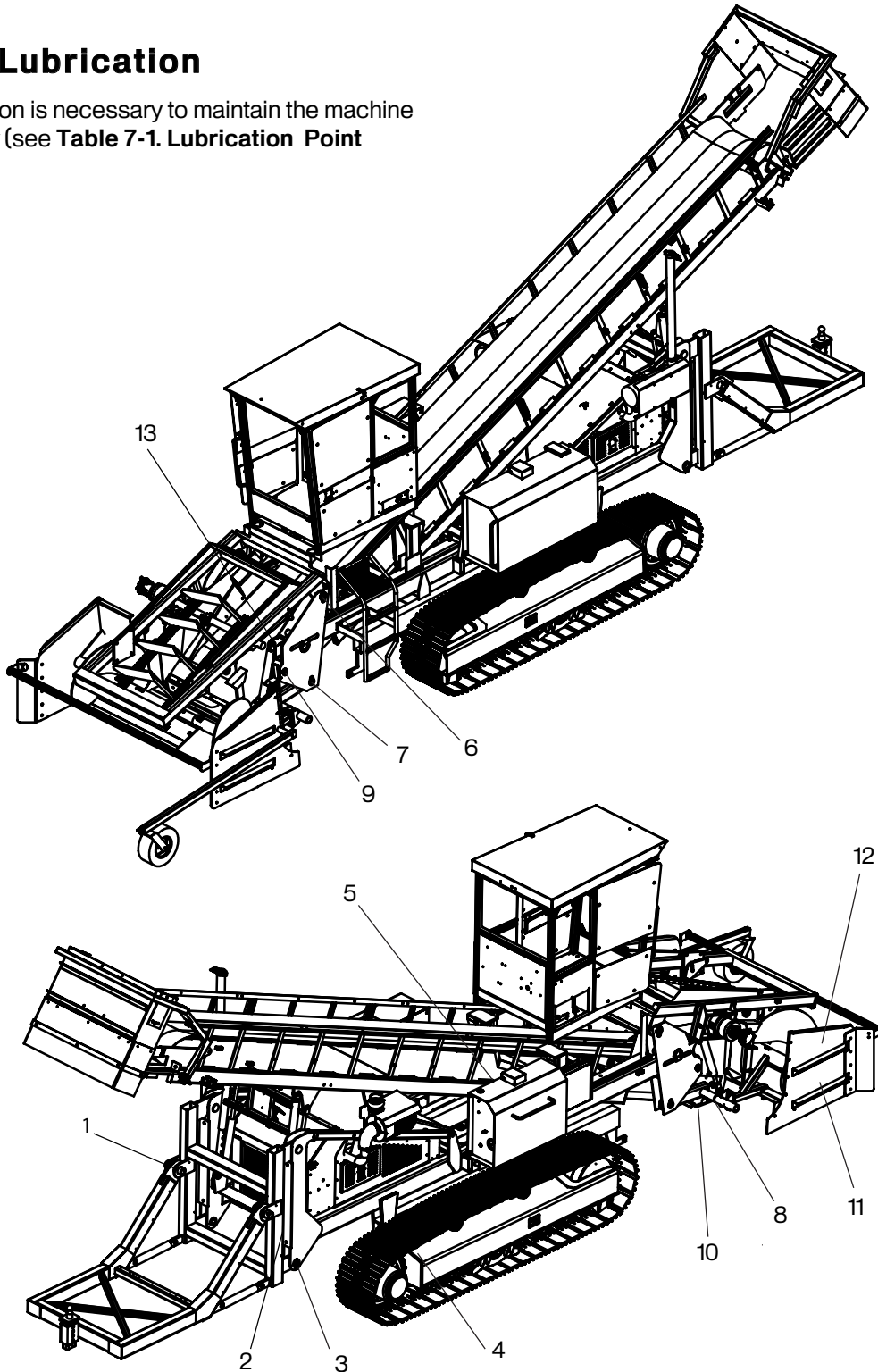

Lubrication Points

Figure 7-8

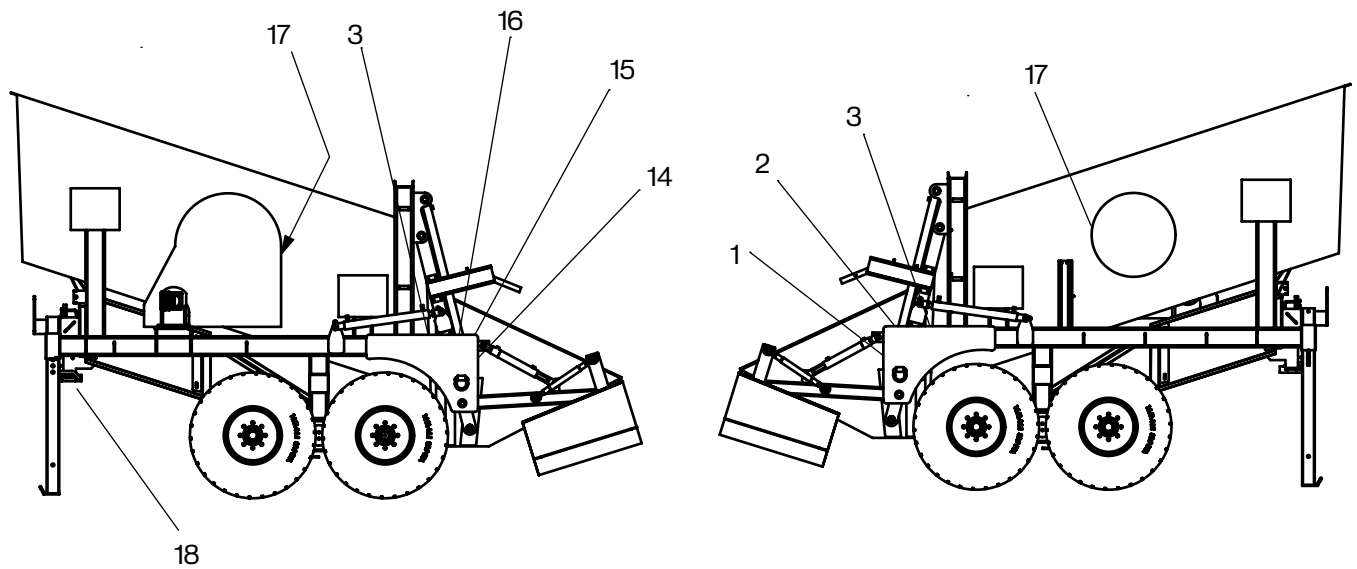

Sifter Lubrication Points

Figure 7-9

Table 7-1. Lubrication Point Schedule

ITEM NO.	TYPE LUB	DESCRIPTION AND LOCATION	INTERVAL
Legend	A	Grease With Shell Avania EP Grease 2 Or Equivalent	Weekly
	B	Spray With An Approved Release Agent or Chain Lube	Weekly
	C	MOBIL SHC 460 (Synthetic Base Stock & Additives)	Weekly
1	A	Generic	Symmetric, Both Sides
2	A	Radiator Hinge	Two Hinges, High and Low
3	B	Generic	Symmetric, Both Sides
4	B	Frame Lift Pivot	Symmetric, Both Sides
5	B	Behind Tank	Symmetric, Both Sides
6	B	Generic	Symmetric, Both Sides
7	B	Generic	Symmetric, Both Sides
8	B	Generic	Symmetric, Both Sides
9	A / B	Generic	Symmetric, Both Sides
10	A	Head Pulley)	Symmetric, Both Sides
11	A	Auger Pointst	Multiple
12	A	Pillow Block	Symmetric, Both Sides
13	A	Feeder Adjuster	Symmetric, Both Sides
14	C	Bucket Lift Arm Pins	Symmetric, Both Sides
15	A	Bucket Dump Ccylinder Pin	Symmetric, Both Sides
16	A	Blade Lift Arm Upper	Symmetric, Both Sides
17	C	Sifter Bearings	Symmetric, Both Sides
18	A	Hitch Latch	Single location

MAINTENANCE ADJUSTMENTS

Conveyor Belt Centering

All part item numbers in the following procedure refer to the parts list for the HEAD PULLEY ASSEMBLY and the associated drawing in the parts manual.

The conveyor belt must be kept centered at all times. This should be checked visually daily. If the belt appears not to be centered proceed as follow:

NOTE: This adjustment is made with the conveyor raised and the belt running. The distance must be the same on both sides of the belt.

WARNING Be sure safety pins have been inserted to prevent conveyor from falling.

1. Measure the distance from both sides of the belt to the frame (**Figure 7-10**).
2. Determine which side has the belt closest to the frame. The adjustment will be made on that side of the belt. If the closest is the drive side proceed with step 2. If the closest is the bearing side, proceed with step 8.
3. Loosen cap screw (24) on both the top and bottom of the drive assembly.
4. Loosen the jam nut (7) and adjust position of drive by adjusting screw (12).
5. Allow conveyor to run several minutes and recheck measurements.

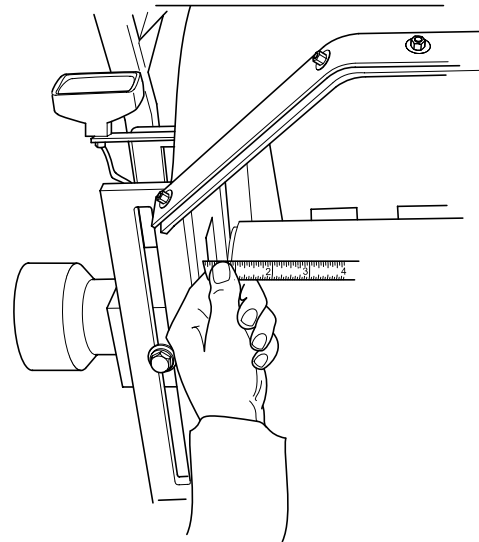

Centering Measurement

Figure 7-10

6. If belt is not centered repeat step 3 and 4. If belt appears to have moved more off center, adjust in the opposite direction.
7. If belt is now centered, tighten jam nut (7) and top and bottom cap screws (24).
8. Loosen bearing support cap screws (5) so bearing position can be changed.
9. Loosen lock nut (7) and adjust bolt (6) as necessary.
10. If belt is not centered repeat step 8 and 9. If belt appears to have moved more off center, adjust in the opposite direction.
11. If belt is now centered, tighten jam nut (7) and top and bottom cap screws (5).

Chains

All part item numbers in the following procedure refer to the parts list for the CONVEYOR PADDLE ASSEMBLY and the associated drawing in the parts manual.

The two chains for the conveyor paddle assembly must be adjusted to provide 1" of play. Perform this adjustment as follows:

1. Check the amount of slack in the chains by pulling up on the center of the chain and check for approximately 1" of play. If the play is correct no adjustment is required. If the chain has too much slack proceed with step 2.
2. Loosen the nuts securing bracket and bearing.
3. Loosen the jam nut of screw .
4. On the drive side, loosen the screws securing the top and bottom of the torque hub mount .
5. Loosen the jam nut on the adjusting screw for the drive side.
6. Adjust both screws the same amount, trying to keep both shafts in line with each other and to get the 1" play required.
7. Tighten jam nuts.
8. Tighten mounting bolts.
9. Recheck the chain for approximately 1" of slack. If necessary repeat the procedure.

Moldboard Cutting Edge

⚠ WARNING Never work under machine without blocking up moldboard.

All part item numbers in the following procedure refer to the parts list for the MOLDBOARD and the associated drawing in the parts manual.

The moldboard cutting edge needs to be replaced when worn. Replace the cutting edge as follows:

1. Raise the moldboard off the ground.

⚠ WARNING Engine must be turned off and the tracks blocked front and rear to prevent motion when servicing the machine.

2. Turn off engine and block the wheels to prevent movement while working on the machine.
3. Clean the area around the cutting edge (2).
4. Remove the eight plow bolts (3) and washers (4) securing the cutting edge (2) to the moldboard (1) and remove the cutting edge (2). Take note of the plastic cutting edge slide plate and replace if necessary also.
5. Attach a new cutting edge (2) with the eight plow bolts (3) and washers (4).
6. Torque plow bolts (3) to 105 ft-lb (145 N.m).
7. Lower moldboard and check to be sure moldboard is flat on the surface.

Conveyor Paddle Blade

All part item numbers in the following procedure refer to the parts list for the CONVEYOR PADDLE ASSEMBLY and the associated drawing in the parts manual.

The paddle blade needs to be replaced when damaged. Replace the paddle blade as follows:

⚠ WARNING Engine must be turned off and the tracks blocked front and rear to prevent motion when servicing the machine.

1. Turn off engine while working on the machine.
2. Clean the area around the paddle blade (6).
3. Remove the four plow bolts and nuts securing the paddle blade (6) to the chain assembly (5) and remove the paddle blade (6).
4. Attach a new paddle blade (6) with the four plow bolts and nuts.
5. Torque plow bolts to 150 ft-lb (205 N.m).

Engine Drive Belt

The engine drive belt should be replaced whenever the belt appears frayed or cracked. This belt drives the alternator as well as the cooling fan. Tension on the belt is maintained by a spring-loaded tensioner.

To replace the belt proceed as follows:

Removal

WARNING Engine must be turned off to prevent motion when servicing the machine.

1. Turn off engine while working on the machine.

NOTE: The spring-loaded belt tensioner must be pivoted away from the drive belt. Pivoting in the wrong direction can damage the tensioner.

2. Using a 3/8-inch square drive, lift the tensioner to relieve pressure on the belt and remove the belt.

Installation

1. Using a 3/8-inch square drive, lift the tensioner and hold.
2. Install the drive belt as shown in **Figure 7-11**.

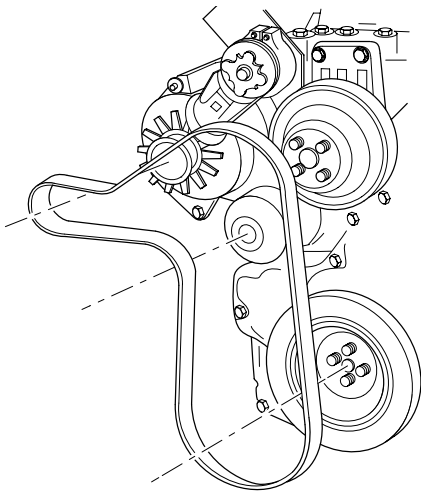

Drive Belt

Figure 7-11

3. Release the tensioner being sure the tensioner is properly pressing against the belt.

Charge Filter

There are two charge filters, one located on each side of the machine. These filters should be changed every 1,000 hours when the hydraulic fluid is changed.

Hydraulic Cylinder Replacement

WARNING Before breaking any circuit connection, make certain that power is off and the system pressure has been released. Lower all vertical cylinders, discharge any accumulators, and block any load whose movement could generate pressure.

Removal

NOTE: Plug and cap all lines and ports when disconnected to prevent entry of dirt into the system.

1. Place a container under the cylinder to catch any hydraulic oil when the lines are disconnected.
2. Disconnect and label the two hoses connected to cylinder fittings.
3. Remove the two clevis pins and cotter pins, securing cylinder.
4. Remove cylinder from machine.

Installation

1. Install the two clevis pins and cotter pins to secure the cylinder.
2. Connect the two hydraulic hoses.
3. Add hydraulic oil, if necessary.
4. Start the engine and operate the cylinder to check for leaks and for proper operation.
5. Stop the engine.

Conveyor Head Pulley Bearing

All part item numbers in the following procedure refer to the parts list for the HEAD PULLEY ASSEMBLY (see *Head Pulley Assembly* in Section 10)

⚠ WARNING This procedure should only be performed with the equipment not operating.

Removal

1. Check that machine is turned off and key is removed from the ignition.
2. Remove the two caps screws (5) and the associated hardware.
3. Slide the bearing (4) off the shaft (15) and remove bearing from machine.

Installation

1. Clean mounting surface.
2. Slide new bearing (4) onto shaft (15).
3. Install front cap screw (5) through bearing mount and hole in frame.
4. Attach nut and washers to cap screw (5) but do not tighten at this time.
5. Install rear cap screw through a washer, then through adjusting bolt (6) and the mounting hole in the frame.
6. Attach nut and washers to cap screw (5).
7. Torque both nuts to 375 ft-lb (508 N.m).
8. Lubricate bearing.

Muffler

All part item numbers in the following procedure refer to the parts list for the MUFFLER ASSEMBLY (see *Muffler Assembly* in Section 10).

⚠ WARNING This procedure should only be performed with the equipment not operating and cooled down. When the machine has been running the muffler will be very hot.

The muffler is mounted to a plate with clamps (9) and has a heat shield (5) on the outside. To replace the muffler proceed as follows:

Removal

1. Be sure engine is off and has had sufficient time for the muffler assembly to cool down.
2. Loosen clamp (1) and disconnect exhaust flex pipe (2).
3. Loosen clamp (6) and remove exhaust stack (7) with rain cap (8).
4. Remove cap screws (14), washer (10), spacer tube (4), washer (10) and nut (13).
5. Slide muffler (3) out of plate with clamps (9).

Installation

1. Slide muffler (3) into plate with clamps (9).
2. Position muffler so that outlet is at right pointing up and input is at left pointing down.
3. Slide elbow with flex tube (2) on muffler inlet and secure with clamp (1).
4. Attach muffler (3) and heat shield (5) using cap screws (14) and washers (10) on outside of heat shield and spacers (4) between heat shield and clamp (9).
5. Secure muffler in clamp using washers (10) and nuts (13).
6. Torque nuts (13) to 31 ft-lb (42 N•m).
7. Attach exhaust stack pipe (7) to muffler with clamp (6).
8. Install rain cap (8) on top of exhaust stack pipe (7).

Maintenance

Radiator Hoses And Radiator

All part item numbers in the following procedure refer to the parts list for the GRILLE AND RADIATOR ASSEMBLY and the associated drawing in the parts manual.

WARNING This procedure should only be performed with the equipment not operating.

1. Turn off ignition, remove key, and allow the engine to cool down before proceeding.

WARNING Do not remove the radiator cap while the engine is still hot. The radiator is under pressure and the hot water can cause serious injury to all persons around.

2. After machine has cooled down, remove the radiator cap (26).
3. Drain radiator into a suitable container large enough to hold the radiator contents, 5.5 Gal (20.8 Liters).
4. To remove upper hose (6), loosen the two hose clamps and disconnect the hose. If clamps are not damaged, retain for installation.
5. To remove lower hose (9), loosen the two hose clamps (10) and disconnect the hose. If clamps are not damaged, retain for installation.
6. Remove radiator cap (26).
7. Remove overflow hose (24) by removing clamp (25).
8. Remove the hardware attaching the radiator (1) to grille and radiator support (2,3).
9. Remove radiator.

NOTICE When installing, bolt radiator mounts to bottom of radiator before frame to prevent binding.

Conveyor Belt

All part item numbers in the following procedure refer to the parts list for the TAIL PULLEY GROUP and the associated drawing in the parts manual.

CAUTION The conveyor belt weights approximately 400 lbs. Belt replacement will require more than one person.

When installing a new belt, the old belt should be used to pull the new belt onto the machine. For belt replacement proceed as follow:

10. Run the existing belt (1) so that the belt joint is in a location suitable for removal.
11. Remove belt lacing pin (2) and then remove old or damaged belt.
12. Install new belt using come a longs or rope to thread the new belt into position to lace together.
13. Secure the two ends of the new belt together with lacing pin (2).
14. Check that new belt is properly adjusted and stays centered. If belt requires adjustment, refer to the adjustment procedure in this section.

Safety Label Installation

Anytime the 3000SS Sand Shark or Sand Sifter has been repainted or the safety labels have been removed, damaged or can't be read, a new set of labels should be ordered and reinstalled for safe operation (see **Safety Label Locations** in Section 2).

1. Be sure that the installation area is clean and dry. Use hot soapy water and dry the area thoroughly before installing decals.
2. Determine the exact position by taking measurements and test fitting before you remove the backing paper.
3. For decals with no top protection paper, determine the decal location and remove the smallest portion of the split backing paper.
4. Align the decal over the specified area and carefully press the small portion with the exposed adhesive backing into place.
5. Peel back the remaining paper and carefully smooth the remaining portion of the decal in place.
6. Small air pockets can be pierced with a pin and smoothed out using the piece of decal backing paper.
7. If the decal has a protective top paper, use hot soapy water on the surface to which the decal is being applied. Leave wet. After determining the location, remove the backing paper and soak the decal in clean soapy water before application. This will help prevent air bubbles in the finished decal.
8. Smooth the decal into place with a sponge and check for air bubbles. Small air pockets may be pierced with a pin and smoothed out. When the decal is completely smoothed out, carefully remove the top paper.

TRACK AND SIFTER

Change Hub Oil

Drain Oil

1. Rotate gearbox until plug B is at the bottom in vertical position.
2. Remove plug.
3. Install plug B after all oil has been drained.

Fill Oil

1. Rotate gearbox until plug A is at the top in vertical position.
2. Fill with 85W90 until it runs out of plug B.
3. Tighten both B and A plugs and let the gearbox run. After a few minutes, stop and check oil level.
4. If necessary, refill with oil.

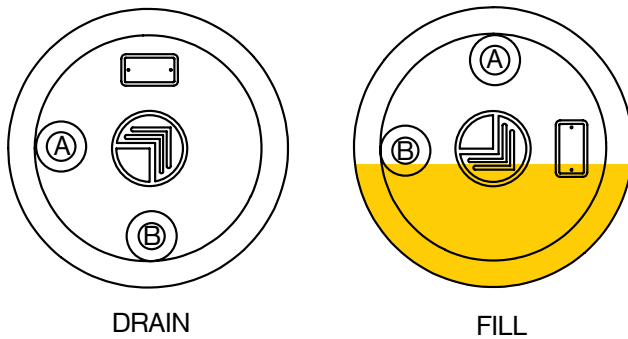

Track Hub Oil
Figure 7-12

Track Adjustment

1. Check regularly the SAG and the recommended one for this size machine is 35mm.
2. Check the bolts after the first 150 hrs of life of the machine and eventually torque properly. The next torque checks need to be done every 500 hrs, but a visual inspection is always recommended prior to operating the machine (**Figure 7-13**).
3. Refer to track drive manufacturer technical manual.

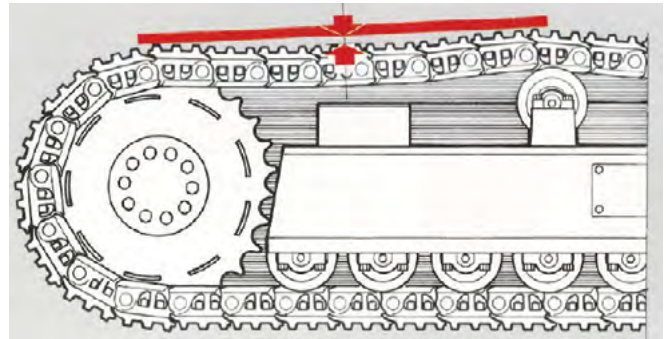

Bearing Removal
Figure 7-13

- 1 - 3 5/8 Diameter Slug
- 2 - Blocks

Wear Charts

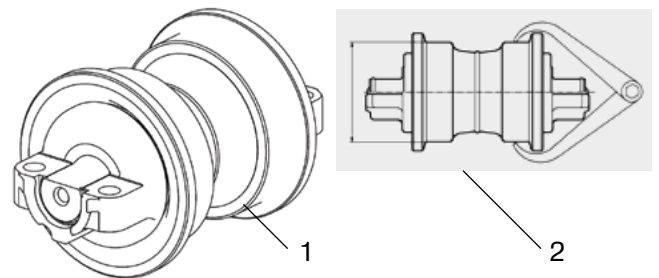

Track Roller Wear
Figure 7-14

- 1 - Track Roller
- 2 - Measurement

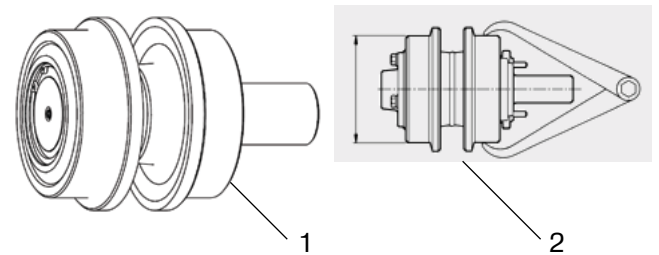

Top Roller Wear
Figure 7-15

- 1 - Top Roller
- 2 - Measurement

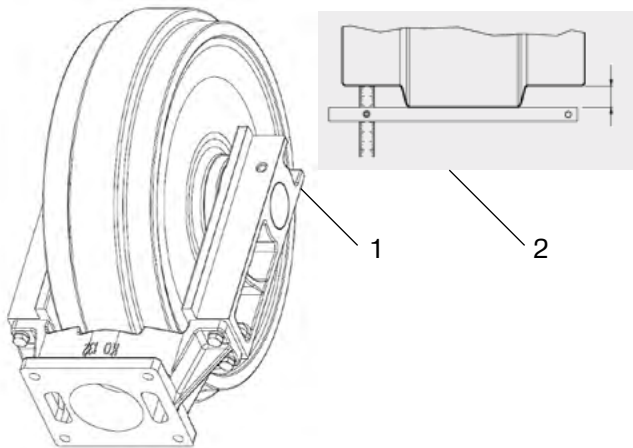

Idler Wear
Figure 7-16

- 1 - Idler
- 2 - Measurement

Figure 7-18

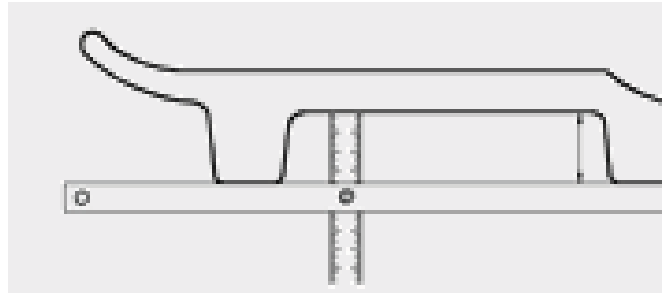

Shoe Wear
Figure 7-19

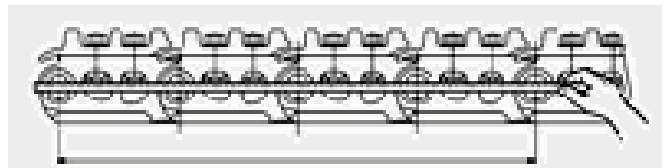

Chain Pitch Wear
Figure 7-20

NOTE: The pitch of a single link is 171.45mm. The chain pitch measure is taken in 4 consecutive sections.

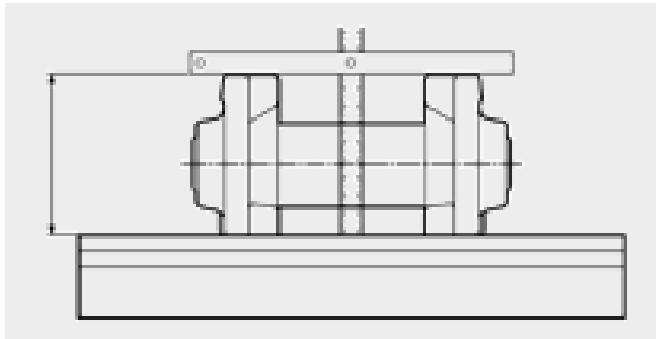

Link Wear
Figure 7-17

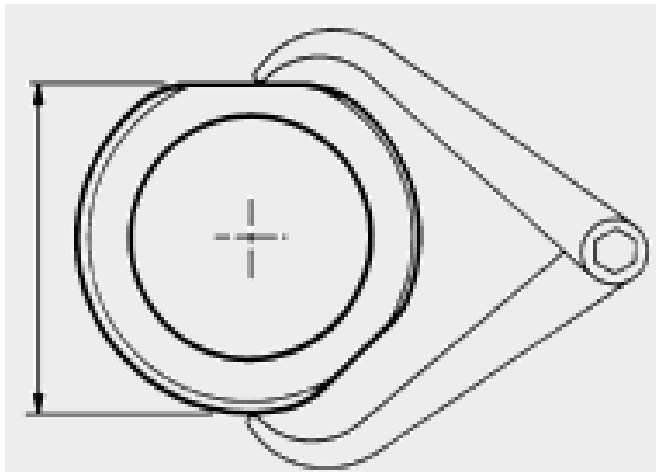

Bushing Wear

Table 7-2. Wear Chart

Measure	TRACK ROLLER		TOP ROLLER		IDLER		LINK		BUSHING		SHOE		CHAIN PITCH	
	MM	IN	MM	IN	MM	IN	MM	IN	MM	IN	MM	IN	MM	IN
New	155.0	6.10	140.0	5.51	17.0	0.67	96.0	3.78	54.0	2.13	25.3	1.00	686.8	27.04
10%	153.8	6.06	138.9	5.47	17.3	0.68	95.4	3.76	53.6	2.11	24.0	0.95	688.0	27.09
20%	152.5	6.00	137.7	5.42	17.7	0.70	94.9	3.74	53.1	2.09	23.0	0.91	689.2	27.13
30%	151.5	5.97	136.6	5.38	18.1	0.71	94.3	3.71	52.5	2.07	21.5	0.85	690.4	27.18
40%	150.5	5.93	135.4	5.33	18.5	0.73	93.7	3.69	52.0	2.05	20.5	0.81	691.6	27.23
50%	149.7	5.89	134.2	5.28	18.9	0.74	93.3	3.67	51.5	2.03	19.0	0.75	692.8	27.28
60%	148.7	5.85	133.1	5.24	19.4	0.76	92.6	3.65	50.7	2.00	18.0	0.71	694.0	27.32
70%	147.6	5.81	131.9	5.19	19.8	0.78	92.1	3.63	49.7	1.96	16.5	0.65	695.2	27.37
80%	146.2	5.76	130.8	5.15	20.3	0.80	91.4	3.60	48.9	1.92	15.0	0.59	696.4	27.42
90%	145.2	5.71	129.0	5.08	21.1	0.83	90.8	3.57	47.6	1.87	14.0	0.55	697.6	27.47
100%	142.3	5.60	127.2	5.01	22.1	0.87	90.0	3.54	46.3	1.82	12.5	0.49	698.8	27.51
110%	139.8	5.50	125.4	4.94	23.3	0.92	89.3	3.52	45.1	1.78	11.5	0.45	701.6	27.62
120%	137.5	5.41	123.5	4.86	24.5	0.97	88.6	3.49	43.7	1.72	10.0	0.39	704.2	27.72

NOTE: The wear chart is referring to normal impact terrain.

Lubrication

Bearing lubrication is extremely critical, due to heavy loading and vibration. Please read and maintain the following steps for good maintenance.

Grease installed at factory: Mobil SHC 460

NOTE: Blending of greases of a different detergent base is likely to result in a marked deterioration of lubricity with the risk of premature bearing failure.

In the event that a grease other than Mobil SHC 460 is used, the bearing must be flushed and cleaned completely, then repacked with the new type of grease.

Add 5 grams every 40 hours, equal to 4 full pumps from Midwestern ind. Supplied grease gun.

Generally, smaller amounts of grease at more frequent intervals is best for any greasing schedule see **Table 7-1. Lubrication Point Schedule.**

Sifter Bearing Housing Replacement

1. Remove belt guard, belts, and pulley (If drive side).
2. Remove weight guard covers.
3. Remove weights.
4. Remove grease line.

5. Remove (8) 5/8-11 x 2-1/2" long bolts from bearing housings.
6. Remove weight guard housing.
7. Install (4) 1/2-13 x 4" pusher bolts; proceed with removal of bearing housing from shaft. Block shaft to maintain position.
8. The shaft should be inspected at this time. If the shaft has wear from the bearing having spun, or grooves at the seal locations, it should be replaced.
9. The shaft must be clean, then install the bearing housing. The bearing is self aligning, and must remain straight while installing. If the bearing needs to be aligned, rotate the inner race. Do not force the bearing into alignment by pounding, as this will damage the bearing. (For units that are used with large amount of water apply Aviation FORM-A-GASKET Sealant Liquid between bearing housing and side sheet before continuing with step 10.)
10. Install bearing housings with (8) new 5/8-11 x 2-1/2" grade 8 Bolts and 5/8" camlock washers, torque to 170 ft. Lbs. Lubed or 220 ft. Lbs. dry.
11. Clean the grease line by pumping in fresh grease, then install the grease line into the bearing housing. Complete bearing housings are packed at the factory, and need no further grease at installation.
12. Install the weights in the same position they were. The weights need to be set the same on both sides of the MEV (see **Counterweights** in Section 7).

13. Install the weight guard covers.
14. Install pulley on shaft and align pulley with sheave on motor (**Figure 7-21**).
15. Install belts and tension (**Figure 7-21**).
16. Install belt guard.

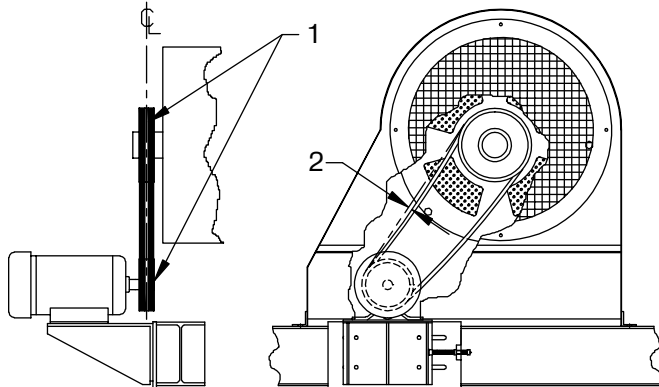

Belt Installation

Figure 7-21

1 - Sheaves

2 - Deflection of 1" at 5 lbs

Bearing Replacement Using Existing Housing

1. Remove the bearing housing cover.
2. Heat the bearing housing to 250°F.
3. Turn the housing upside down. The bearing can be removed by using a 3 5/8" dia. slug thru the bore, and applying pressure. The seal should be removed at this time (**Figure 7-22**).

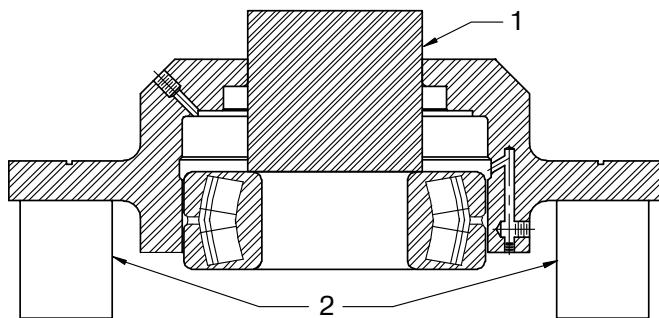

Bearing Removal

Figure 7-22

1 - 3 5/8 Diameter Slug

2 - Blocks

4. The housing needs to be inspected. If the bearing spun in the housing, or if there are other signs of severe damage such as heavy gouging, or cracks, the housing needs to be replaced.
5. The housing must be cleaned, any burrs removed, and the grease holes cleaned out.
6. Install a new seal in the housing, the seal is to be installed with the writing on the seal facing up toward the bearing (**Figure 7-23**).
7. Heat the housing to 200°F.
8. Lay the housing face up, start the bearing in as straight as possible. The bearing should drop in. If not, apply some pressure to the outer race of the bearing, NEVER PUSH ON THE INNER RACE, as this will damage the bearing. If the bearing comes out of alignment, it can be aligned by rotating the bearing. Do not force the bearing into alignment by pounding, as this will damage the bearing.
9. The bearing must be packed with new grease. This can be done by installing a grease fitting into the housing. Use the fitting on the top of the housing (do not use the fitting on the bottom). As grease is pumped in, rotate the inner race until the bearing is full of grease.
10. The seal in the bearing cover should be replaced with the writing on the seal facing in toward the bearing, and a new O ring installed.
11. Install the spacer ring, then the bearing cover, and torque bolts (see **Screen Removal and Installation** in Section 7).
12. Follow instructions in **Sifter Bearing Housing Replacement**.

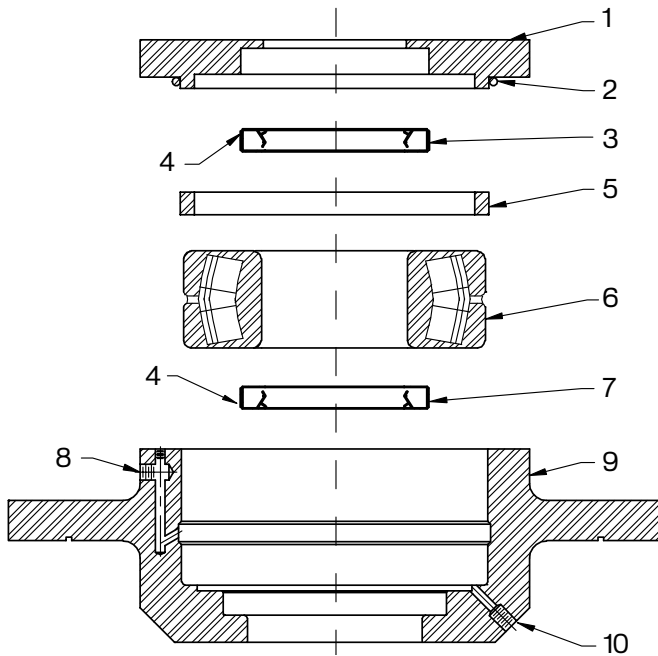

Bearing Assembly

Figure 7-23

- 1 - Bearing Cover
- 2 - O-Ring
- 3 - Cover Seal
- 4 - Writing on seal facing toward bearing
- 5 - Spacer Ring
- 6 - Bearing
- 7 - Bearing Seal
- 8 - Grease Fitting
- 9 - Bearing Housing
- 10 - Relief Fitting

Counterweights

1. Add-on weights can be bolted on either side or both sides of base weight.
2. Keep 2 bolts in plates at all times.
3. Add-on weights must be exactly same on each side of unit.
4. Adding additional weights other than those supplied by Midwestern will automatically void warranty.

NOTE: Torque to 110 ft-lbs. (5/8-11 bolt, 5/8 camlock).

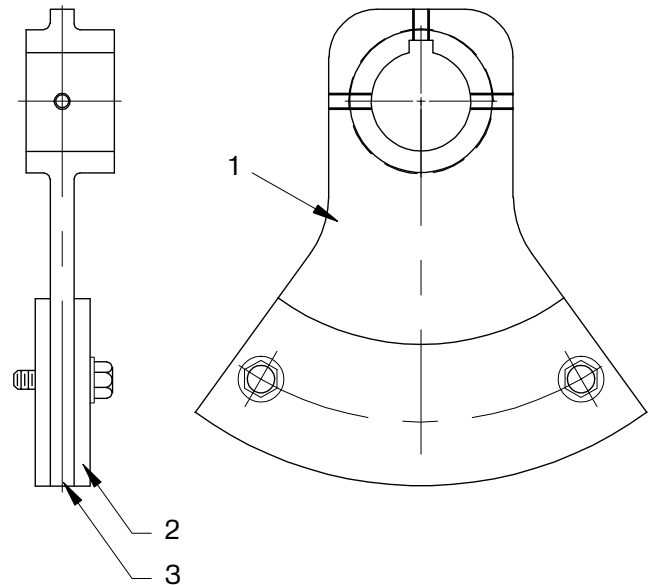

Counterweights

Figure 7-24

- 1 - Standard Counterweight
- 2 - Add-On Weights
- 3 - Fixed Weights

NOTE: The base weights on both sides must be the same thickness if add-on weights are used, they must be the same on both sides of the unit.

Screen Panel Tensioning

Screen panel tensioning is one of the most important aspects of any screening equipment. Insufficient screen tension causes not only poor separation and noisy operation but can destroy a screen panel. The Sand Sifter is designed for easy screen changing and tensioning.

Proper screen panel tension is based on wire diameter of a given screen. As the Sand Sifter uses three or four draw bar studs with heavy-duty coil springs, proper tension is determined as the springs are compressed to a specific length.

The screen tensioning drawing in this section indicates proper positioning of tension gauge (**Figure 7-29**). Included are listings of all tensioning dimensions for Sand Sifter screens. Supplied with each Sand Sifter is a "T"-bar, and two flat bars to facilitate the installation and removal of finer "limber" screens.

Also if ball trays are used, when screens have worn check to make sure no ball's have been lost, if so, follow ball installation (see **Ball Installation** in Section 7).

The following are basic screen changing steps:

1. Remove jam nuts and safety guard bar.
2. Loosen tensioning nuts and push draw bar forward. It is not necessary to remove tension springs, nuts, or washers completely.
3. Unhook old screen at discharge end and slide out the back of unit.
4. Slide new screen into place using "T"-bar if necessary (see **Screen Removal and Installation** in Section 7). Fine mesh screens are reversible and can be installed either end first.
5. For fine mesh screen installation install flat bars before installing screen with "T"-bar (see **Screen Removal and Installation** in Section 7).
6. Screens with a wire diameter of .092" and larger, have a bend near one of the hooks. This hook goes on the discharge end.
7. Make sure both hooks are properly seated and continue to check these while tensioning is under way. It is often suitable to bump hooks into place with a mallet or hardwood block.

8. Tighten the tension nuts evenly starting from the center to the outside until the tension springs compress to the proper dimension."Table 4-8. **Miscellaneous Specifications**" on page 4-5
9. Replace safety guard bars and jam nuts.
10. New screen panels tend to relax and break in initially. Their tension should be checked several times after operating by simply holding the gauge next to each spring and verifying proper compression.

Motor External Wiring

Starting and over-load control devices must be matched to motor rating. For safety or convenience, they may need to be installed some distance from the motor. Follow the control manufacturer's instruction to make proper installation and connections.

Observe the following:

1. Momentarily energize the motor to check that rotation is in the proper direction.
2. Motor is 1800 R.P.M. unit is sheaved to run at 1250 R.P.M. max.

Spreader Bar

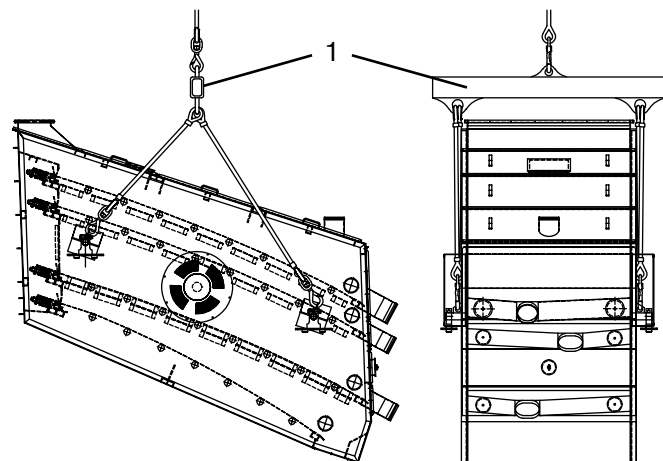

Spreader Bar

Figure 7-25

1 - Spreader Bar

Screen Removal and Installation

1. Remove old screen.
2. Put flat bars in suggested location shown in drawing (to help prevent screens from catching on pipes and tension supports).
3. Slide new screen into place using "T" Bar as guide.
4. Make sure hook is properly seated at front tension support.
5. Hook screen over angle Draw Bar. Make sure screen and hook is properly seated.
6. Tighten screen to proper tension.

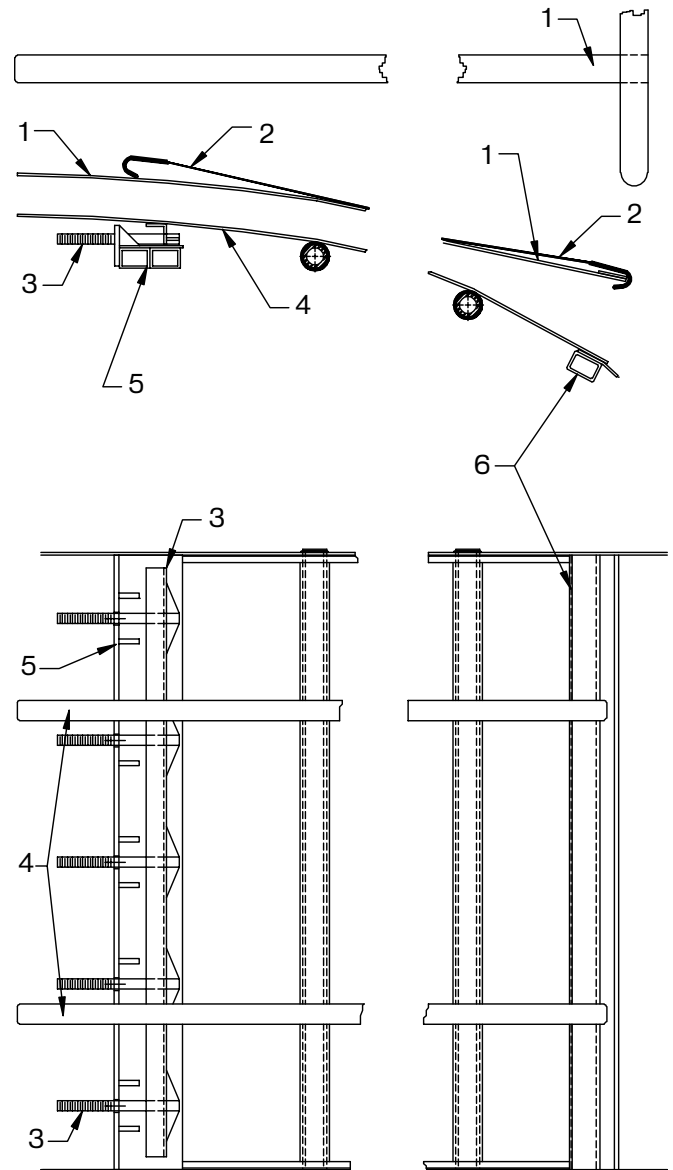

Screen Removal

Figure 7-26

- 1 - "T" Bar
- 2 - Screen
- 3 - Draw Bar
- 4 - Flat Bar
- 5 - Back Tension Support
- 6 - Front Tension Support

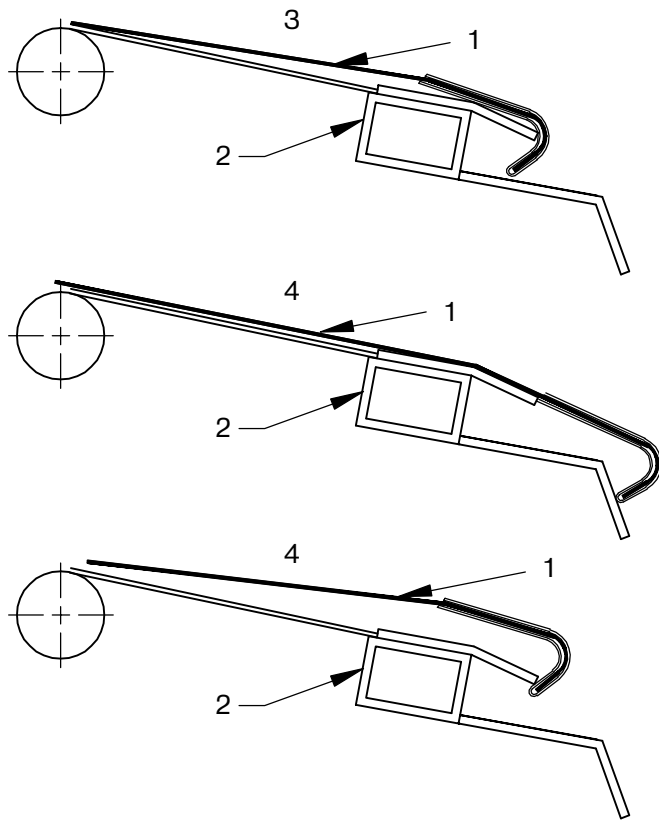

Screen Installation

Figure 7-27

- 1 - Screen
- 2 - Tension Tube
- 3 - Proper Installation
- 4 - Improper Installation

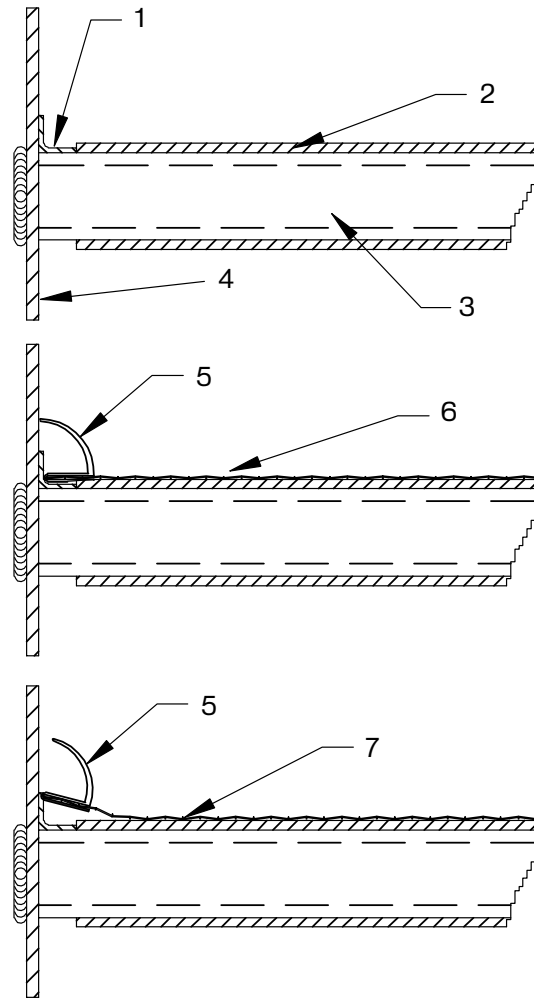

Screen Installation Detail

Figure 7-28

- 1 - Ledge Angle
- 2 - Rubber Piper Cover
- 3 - Support Pipe
- 4 - Side Sheet
- 5 - Rubber Edging
- 6 - Proper Screen Installation
- 7 - Improper Screen Installation

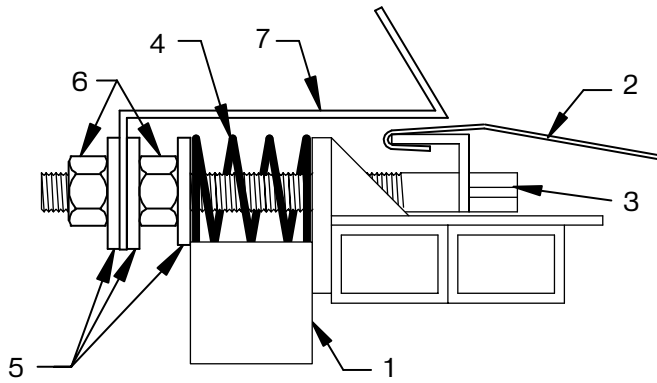

Screen Tension Gauge

Figure 7-29

- 1 - Tension Gauge (2 1/8")
- 2 - Screen
- 3 - Draw Bar Bolt
- 4 - Spring
- 5 - Washer
- 6 - Nut
- 7 - Guard Bar

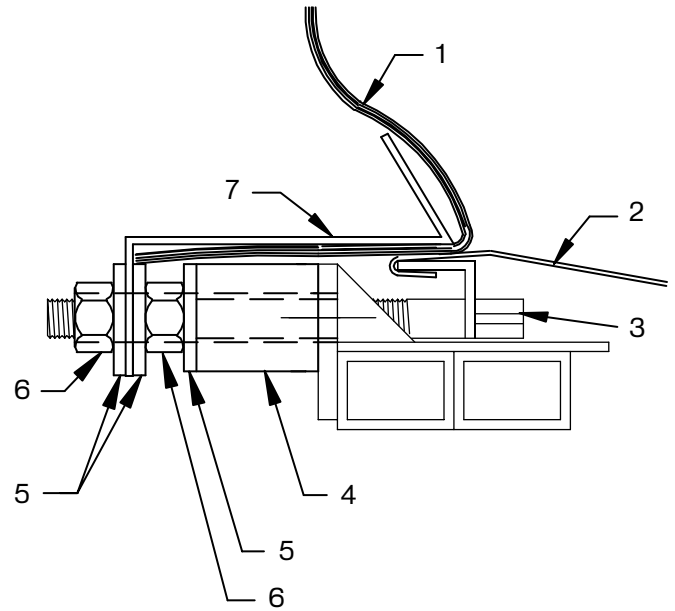

**Screens w/ .135" & Greater Wire Diameter Spacers
Used Instead Of Springs**

Figure 7-31

- 1 - Rubber Curtain
- 2 - Screen
- 3 - Studs
- 4 - Spacer
- 5 - Washer
- 6 - Nut
- 7 - Guard Bar

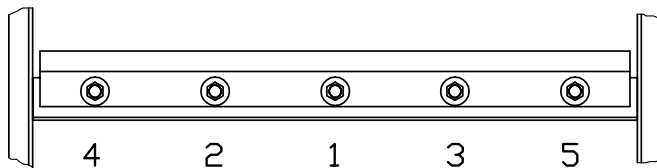

Proper Tensioning Order for Draw Bar

Figure 7-30

Installation For Decks With Screens

For use on Sand Sifter 5'X10' 1-5 deck units.

Curtain: 60 5/8" wide

1. Install Screen.
2. Hook Screen on Draw Bar and tension to the correct setting.
3. Lay curtain on the screen back to the end of the spring assembly.
4. Install guard bar making sure not to move curtain (**Figure 7-32**).

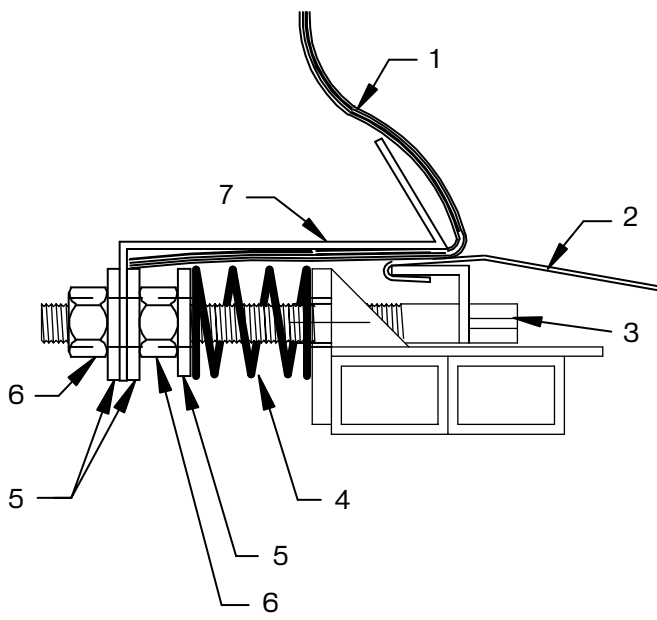

Spring

Figure 7-32

- 1 - Rubber Curtain
- 2 - Screen
- 3 - Studs
- 4 - Spring
- 5 - Washer
- 6 - Nut
- 7 - Guard Bar

Installation For Decks Without Screens

For use on Sand Sifter 5'X10' 1-5 deck units.

Curtain: 60 5/8" wide

1. Apply curtain using necessary holes to Draw Bar Studs.
2. Assemble Draw Bar with washers, springs, and nuts, on studs.
3. Tension draw bar to blocks 2 1/4".
4. Apply guard bar with remaining washers and nuts.

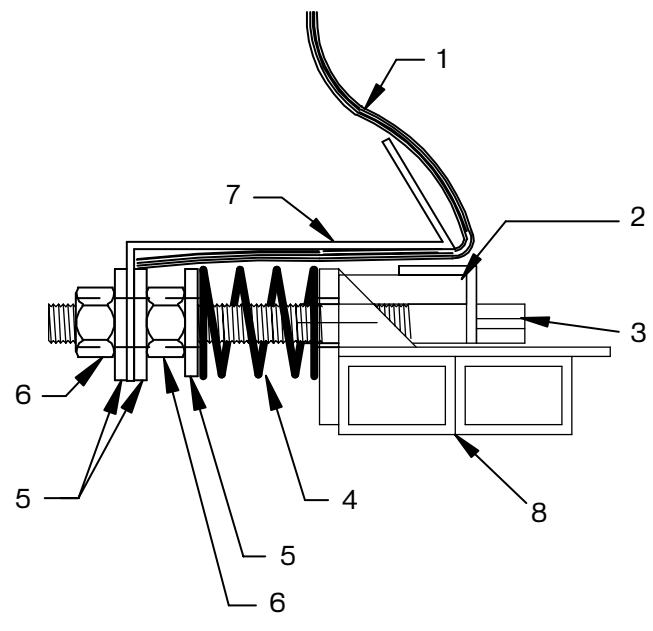

Spacer

Figure 7-33

- 1 - Rubber Curtain
- 2 - Block
- 3 - Studs
- 4 - Spacer
- 5 - Washer
- 6 - Nut
- 7 - Guard Bar
- 8 - Tension Assembly

Fines Pan Installation

For use on Sand Sifter 5'X10' 1-4 deck units.

Curtain: 60 5/8" wide

1. Install Fines Pan.
2. Attach draw bar with second and fourth studs only (torque to 130 ft lbs).
3. Lay curtain on the Pan Back to the end of the tension assembly.
4. Attach guard bar making sure not to move curtain, with the remaining three studs on the draw bar using large washers and nuts (torque to 130 ft lbs).
5. Remove nuts from the first two studs.
6. Reattach nuts using large washers (torque to 130 ft lbs).
7. Attach second set of nuts (torque to 130 ft lbs).

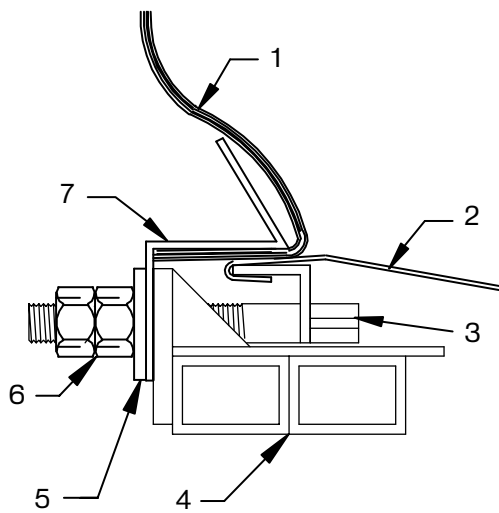

Spacer

Figure 7-34

- 1 - Rubber Curtain
- 2 - Fines Pan
- 3 - Studs
- 4 - Tension Assembly
- 5 - Washer
- 6 - Nut
- 7 - Guard Bar

Ball Installation

1. Lock-out power to machine.
2. Remove screen cloth from desired deck.
3. Place elbow of ball distributor into compartment to be filled.
4. Drop required number of balls into pipe.
5. Turn pipe sideways to release balls.
6. Repeat procedure until all compartments have recommended number of balls.
7. Replace screen cloth.

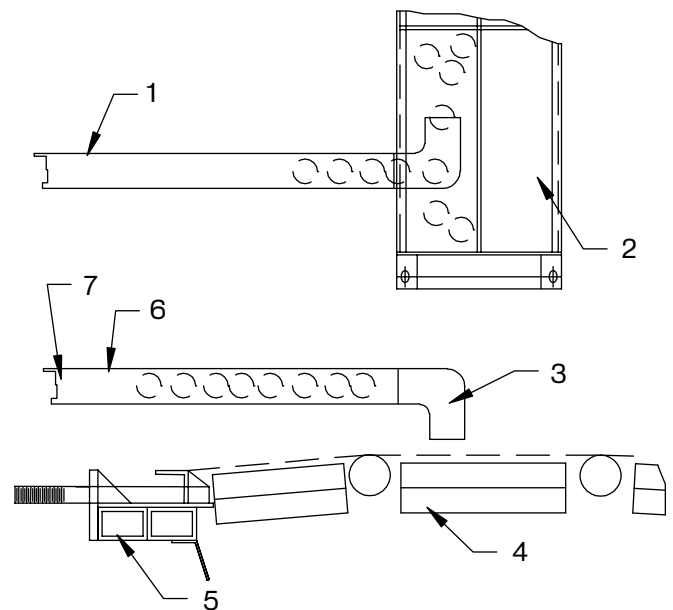

Spacer

Figure 7-35

- 1 - Ball Distributor
- 2 - Ball Tray Compartment
- 3 - 90° Elbow Glued To End Of Pipe
- 4 - Ball Tray Assembly
- 5 - Back Tension Support
- 6 - Heat Pipe and Arch to Configuration of Deck
- 7 - 1 1/2" Schedule 40 Plastic Pipe 10 ft Long

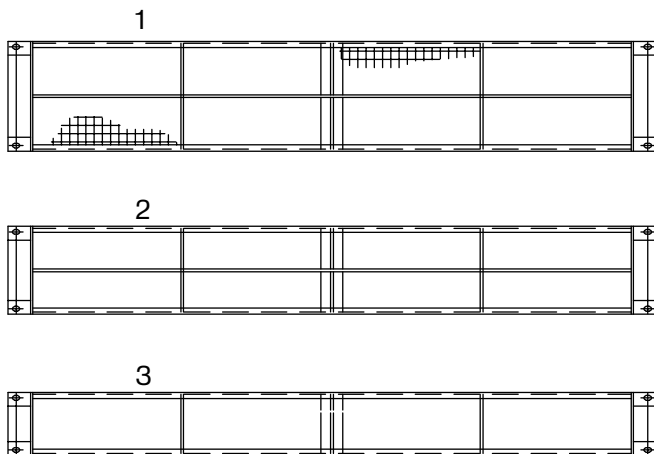

NOTE: Middle Ball Trays require 40 balls.

Feed End Ball Trays require 32 balls.

Discharge End Ball Trays require 16 balls.

Distribute balls evenly in all compartments.

Ball Compartments

Figure 7-36

1 - Middle Ball Tray

2 - Feed End Ball Tray

3 - Discharge End Ball Tray

Table 7-3. Proper Tensioning for Tensil Bolting Cloth Screen Panels on MEV

MESH	WIRE DIA.	OPENING	SPRING COLOR	INCHES	LBS. PULL EA.
16 w/backup	0.0090	0.0535	Yellow	2 1/8	1,050
18 w/backup		0.0466			
20 w/backup		0.0410			
22 w/backup	0.0075	0.0380			
24 w/backup		0.0342			
26 w/backup		0.0310			
28 w/backup		0.0282			
30 w/backup	0.0065	0.0268			
32 w/backup		0.0248			
34 w/backup		0.0229			
36 w/backup		0.0213			
38 w/backup		0.0198			
40 w/backup		0.0185			
42 w/backup		0.0055			
44 w/backup	0.0172				
46 w/backup	0.0162				
48 w/backup	0.0153				
50 w/backup	0.0145				
52 w/backup	0.0137				
54 w/backup	0.0130				
58 w/backup	0.0045	0.0127			
60 w/backup		0.0122			
62 w/backup		0.0116			
64 w/backup		0.0111			
70 w/backup	0.0037	0.0106			
72 w/backup		0.0102			
74 w/backup		0.0098			
76 w/backup		0.0095			
78 w/backup		0.0091			
80 w/backup	0.0035	0.0088			
84 w/backup		0.0084			
88 w/backup		0.0079			
90 w/backup		0.0076			
94 w/backup		0.0071			
105 w/backup	0.0030	0.0065			
120 w/backup	0.0025	0.0058			
145 w/backup	0.0022	0.0047			
165 w/backup	0.0019	0.0042			
200 w/backup	0.0016	0.0034			
230 w/backup	0.0014	0.0029			

Table 7-4. Proper Tensioning for Market Grade Screen Panels on MEV

MESH	WIRE DIA.	OPENING	SPRING COLOR	INCHES	LBS. PULL EA.
2	0.063	0.437	Yellow	2 1/8	1,050
3	0.054	0.279			
4	0.0475	0.2023			
4	0.063	0.187			
5	0.041	0.159			
6	0.0348	0.1318			
7	0.035	0.108			
8	0.0286	0.0964			
10	0.0258	0.0742			
11	0.018	0.073			
12	0.023	0.063			
14	0.0204	0.051			
16	0.0181	0.0445			
18	0.0173	0.0386			
20	0.0162	0.034			
24	0.014	0.0277			
30	0.0128	0.0203			
35	0.0118	0.0176			
40	0.0104	.015			
50	0.009	0.011			
60	0.0075	0.0092			
80	0.0055	0.007			
100	0.0045	0.0055			
120	0.0037	0.0046			
150	0.0026	0.0041			

NOTE: When tensioning screens with a backup utilize the tensioning information on the backup screen.
 For example: 50 Mesh MG. with 11 Mesh MG. backup at 1,050 lbs. pull each, 2 1/8", utilizing yellow springs.
 For Mill Grade, utilize the tensioning information for market grade.

Table 7-5. Proper Tensioning for Screen Panels on Sand Sifter

SQUARE OPENING		WIRE DIAMETER		SPRING COLOR	INCHES	LBS. PULL EA.			
INCHES	MM	INCHES	MM						
4	100	0.375	9.5	Spacer	2 1/8	2,100			
3 1/2	90	0.312	7.9						
3	76	0.250	6.3						
2 1/2	63		6.3						
2	50		6.3						
1 1/2	38	0.192	4.8				Yellow	2 1/8	1,575
1 1/4	32	0.162	4.1						
1	25	0.120	3						
3/4	19		3						
5/8	16	0.092	2.3						
1/2	12.5	0.080	2						
3/8	9.5	0.072	1.8						
5/16	7.9	0.063	1.6						
1/4	6.4	0.047	1.2						
3/16	4.8	0.041	1						
5/32	4		1						
1/8	3.2	0.035	0.9	1,050					
3/32	2.4		0.9						
1/16	1.6		0.9						

Table 7-6. Proper Tensioning for Screen Panels on Sand Sifter *Interkleen™*

OPENING		WIRE DIA.	SPRING COLOR	INCHES	LBS. PULL EA.
INCHES	MM	INCHES			
1/2	12.5	0.08	vYellow	2 1/8	2,100
7/16	11.1	0.072			
3/8	9.5				
5/16	7.9	0.063			
1/4	6.4	0.047			
3/16	4.8	0.041			
1/8	3.2	0.035			
3/32	2.4				
0.08	2.0	0.028			

14" Slot Length

NOTES



Section 8

TROUBLESHOOTING

	Page
Troubleshooting	8-1
Troubleshooting Chart	8-2

TROUBLESHOOTING CHART

The troubleshooting charts below identify the most common symptoms of failure. Use these charts to help identify the failed component and possible remedies.

If the problem persists, see your authorized LeeBoy Dealer (see **Contact Information** in Section 3).

Table 8-1. Troubleshooting Chart

SYMPTOM	CAUSE	REMEDY
Engine will not turn over	Battery low	Check batteries
	Ignition switch defective	Check ignition switch
	Controls not in neutral	Check safety neutral switches
	Engine ground corroded	See engine manual
	E-STOP is engaged	Manually release E-STOP
Engine will not start but does "turn-over"	Low fuel level	Check fuel in tank
	Contaminated fuel	Drain fuel tank and refill
	Fuel flow cutoff	Check fuel cutoff
		Check power to fuel cutoff
	See engine manual	
Sand Shark won't move	Hydraulic fluid level low	Check hydraulic oil level
	Parking brake not released (E-STOP)	Release parking brake (E-STOP)
	Run / Stop switch in "Stop" position	Place dual directional joysticks in neutral position, toggle Run/Stop switch to "Run" mode.
	Drive motor defective	Check drive motor
	Hydraulic pump pressure too low	Check hydraulic pump pressure
	Pump de-stroke valve defective	Check pump de-stroke valve
Hydraulic control valve doesn't function	Hydraulic oil level too low	Check hydraulic oil level
	Relief valve stuck	Check relief valve to see if stuck open
	Suction filter clogged	Check hydraulic suction filter
E-STOP not functioning	Parking brake switch defective	Check parking brake switch
	Brake circuit not complete	Check wire connections
	Solenoid valve defective	Check solenoid valve
Feeder will not turn	Hydraulic fluid level low	Check hydraulic fluid level
	Hydraulic filter clogged	Check hydraulic fluid filter
	Obstruction blocking chains	Visually inspect blades and chains for obstructions
	Dirty hydraulic oil	Replace or clean
	Hydraulic pressure low at motor	Check pressure at motor
	Run / stop switch in "Stop" position	Place dual directional joysticks in neutral position, toggle Run/Stop switch to "Run" mode.

Table 8-1. Troubleshooting Chart (continued)

SYMPTOM	CAUSE	REMEDY
Conveyor belt will not run	Hydraulic fluid level low	Check hydraulic fluid level
	Hydraulic filter clogged	Check hydraulic fluid filter
	Conveyor speed knob is in neutral	Turn to the On position and adjust the desired direction. "Figure 5-5" on page 5-10.
	Run / Stop switch is in stop position	Place dual directional joysticks in neutral position, toggle Run/Stop switch to "Run" mode
Track Misaligned	Improper installation or track tension while operating	Re-install / properly tension track
Remote System not responding	Batteries dead	Replace with fresh batteries (3 x D-size, 1.5V)
	Machine out of range	Get closer to working machine
Machine is "corkscrewing" - slowly tilting to one side	Front Moldboard cutting edge digging in too deeply or not deep enough	Adjust cutting edge
Machine is "porpoising" - slowly moving up and down	Ground level varies too quickly for machine auto-leveling (TopCon V) to adapt	Slow machine down to give TopCon V system time to auto-level machine
		Run machine in manual mode until vertical tracking levels out; re-engage TopCon V
Poor sifting quality	Sifter overloading - too much material	Slow conveyor feed rate Slow machine travel rate
	Screen size not correct for application	Install appropriate screen size for desired application results
	Improper sifter angle	Adjust hitch angle / hitch cylinder
	Poor spread of material to sifter	Adjust deflector angle / cylinder
Machine will not turn	Machine in High Gear	Adjust two-speed to Low Gear
Cameras not working	Poor connection	Check, secure all wire connections
	Camera dirty	Clean
Dump box crashes into rear strike-off	Dump Box too low before dump initiated	Lift Dump Box before tilting (dumping)
Sifter vibration not working properly	Motor speed incorrect	Adjust flow control to motor
	Belt tension not correct	Adjust belt tension
	Faulty electrical connection	Check electrical connection
Machine riding on sand at rear axle / Too much sand at rear strike-off	Mid or pre-strike-off blade improperly adjusted	Adjust pre-strike-off blade down

NOTES



Section 9

SCHEMATICS

	Page
Schematics	9-1
Main Harness	9-3
Cab Harness.	9-5
Plus One Harness	9-7
Manifold Harness	9-9
CAL / OPT / HI Harness	9-11
LH Joysticks Harness	9-13
RH Joysticks Harness	9-15
Overall Harness 1 of 6	9-17
Overall Harness 2 of 6	9-19
Overall Harness 3 of 6	9-21
Overall Harness 4 of 6	9-23
Overall Harness 5 of 6	9-25
Overall Harness 6 of 6	9-27
Main Hydraulic.	9-29
Sand Sifter (MEV150) Hydraulic	9-31

Main Harness

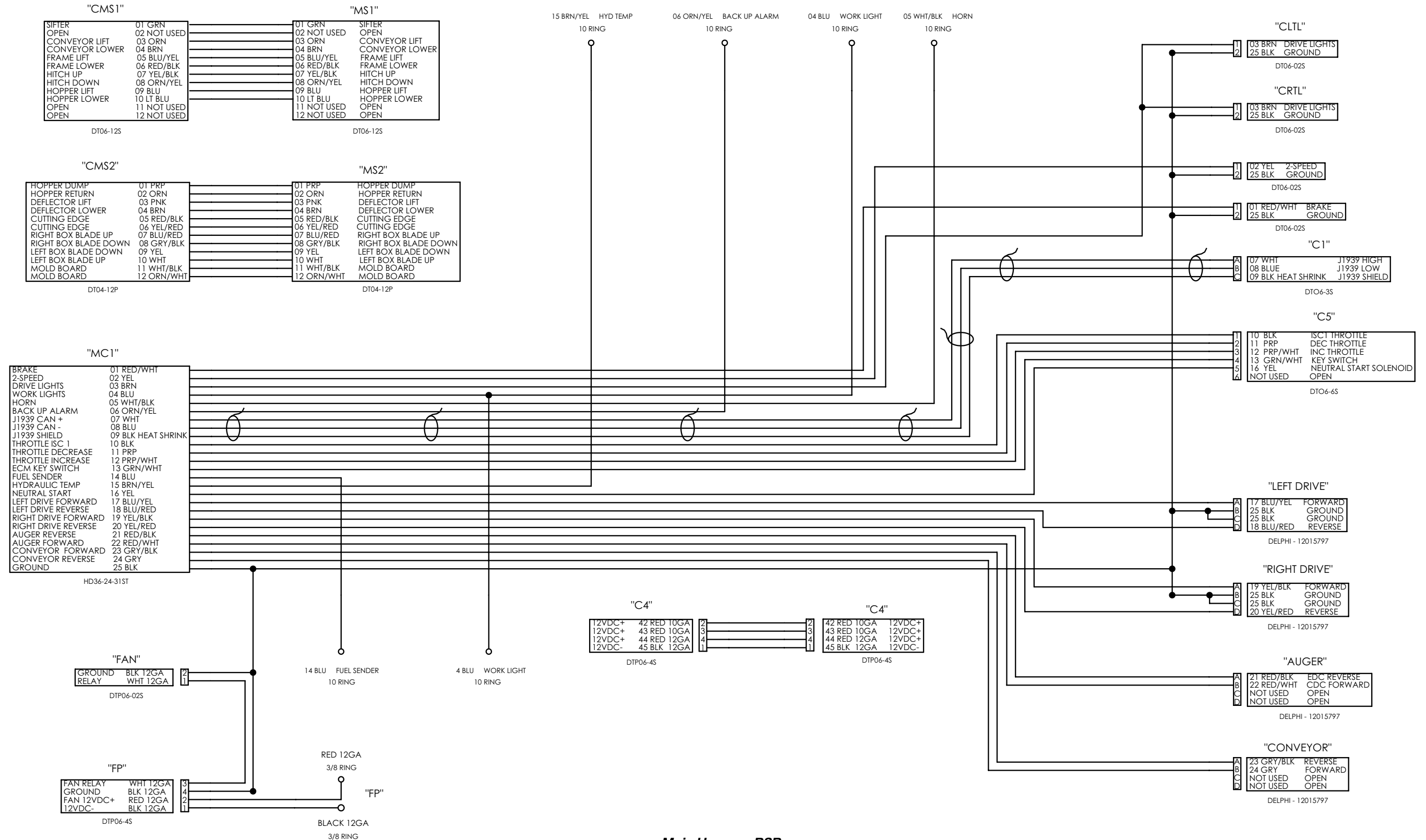

Main Harness P2P

Figure 9-1

Cab Harness

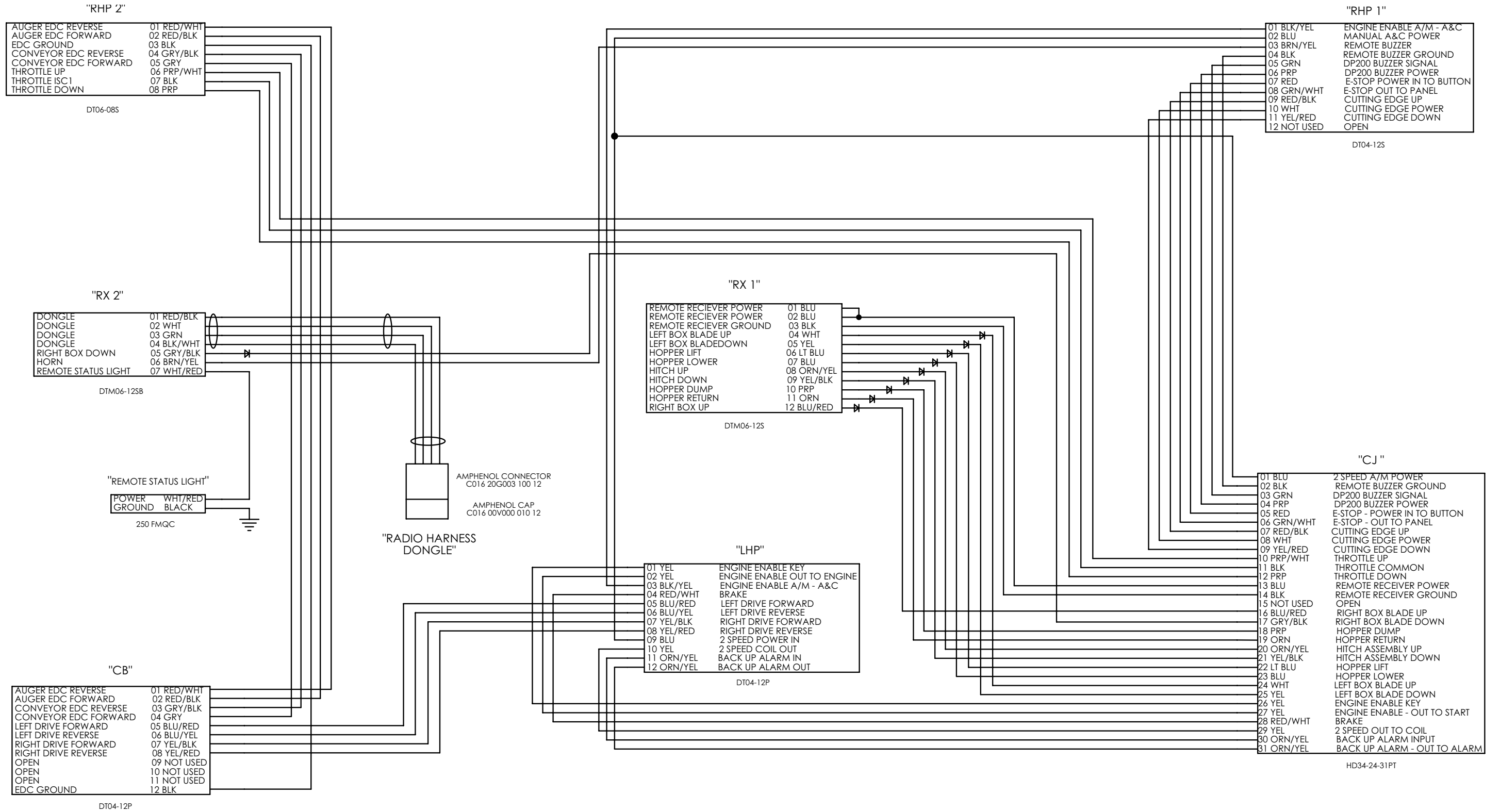

Cab Harness P2P

Figure 9-2

Plus One Harness

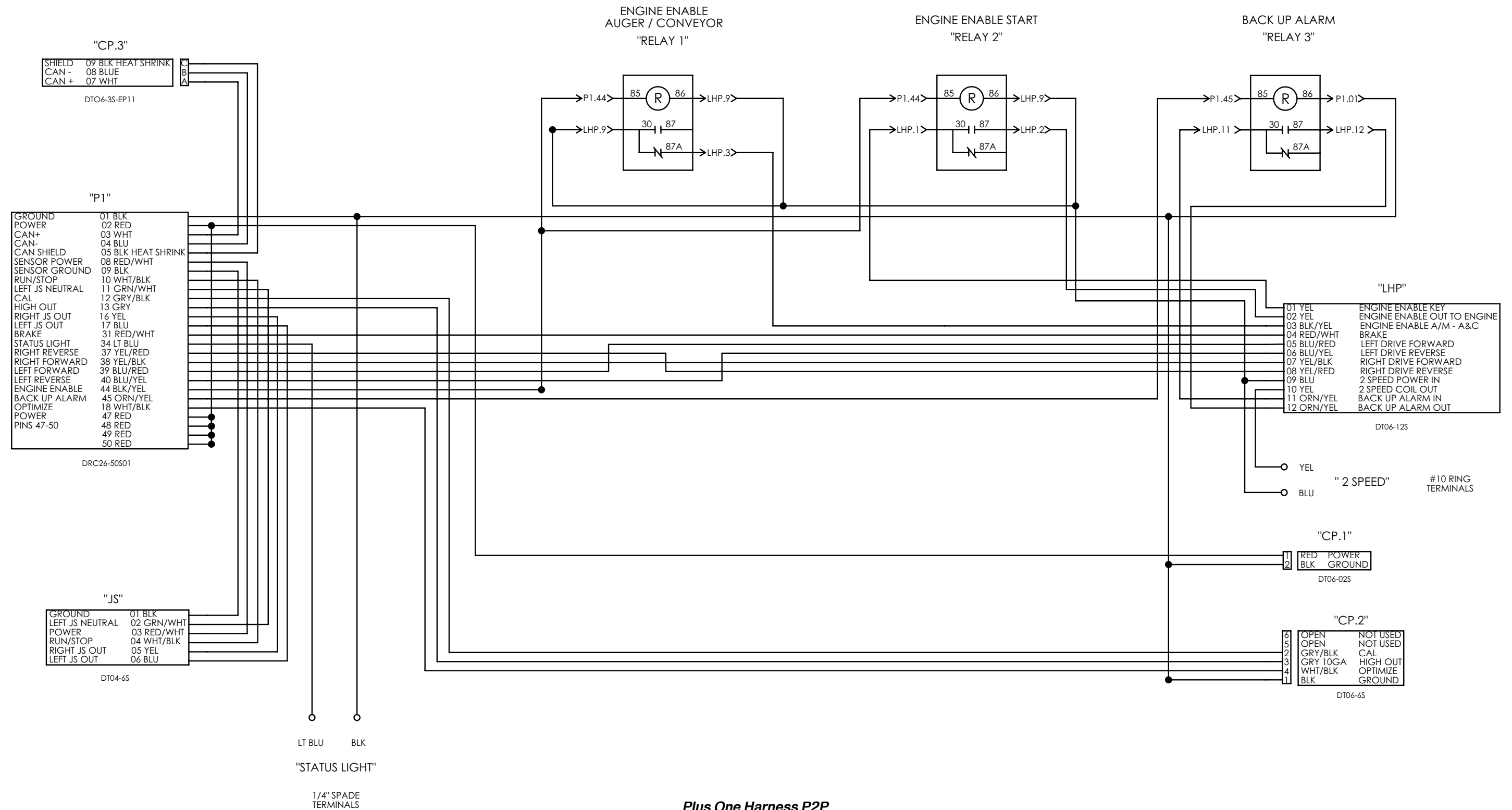

Plus One Harness P2P

Figure 9-3

Manifold Harness

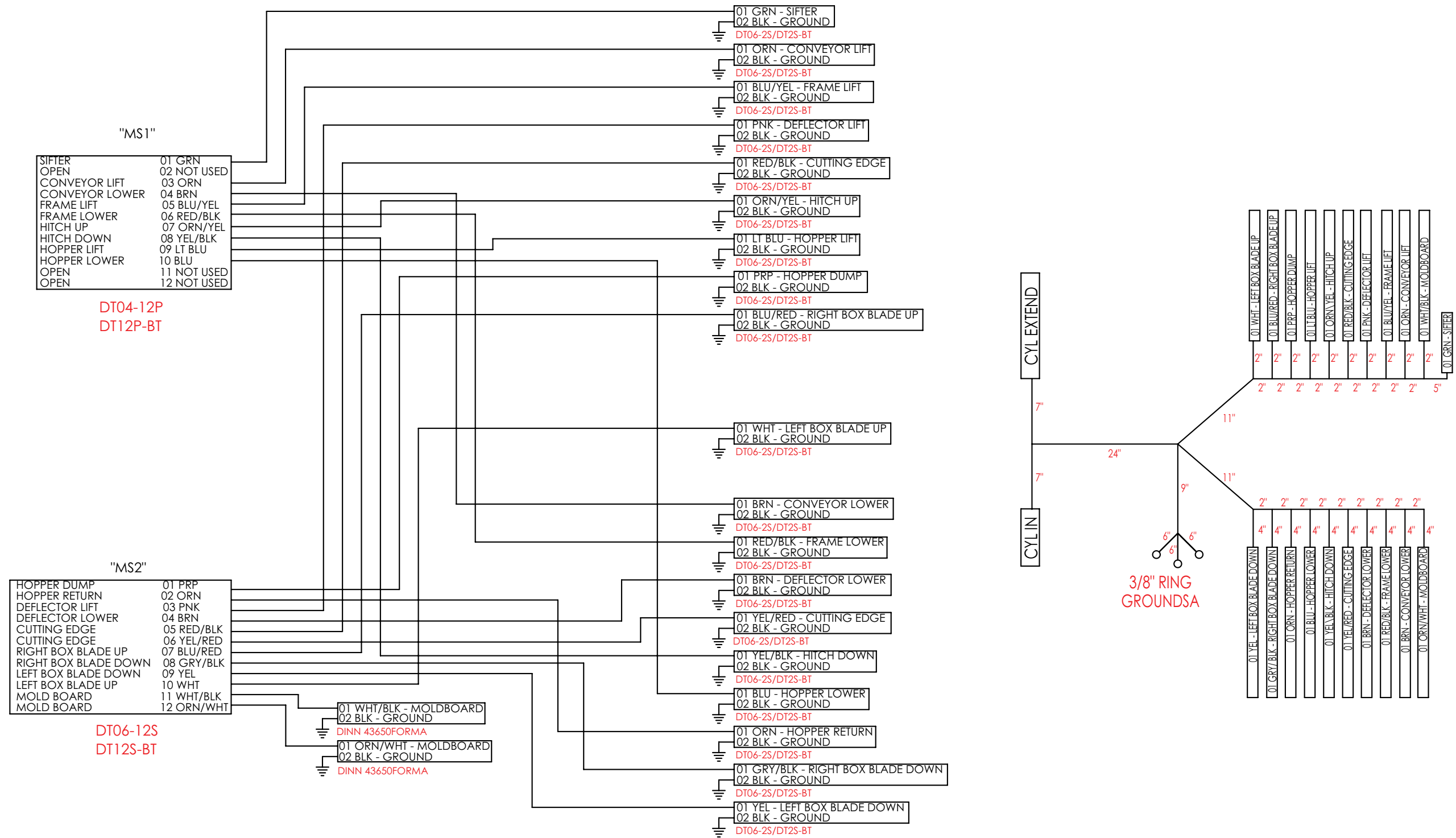

Manifold Harness Layout

Figure 9-4

CAL / OPT / HI Harness

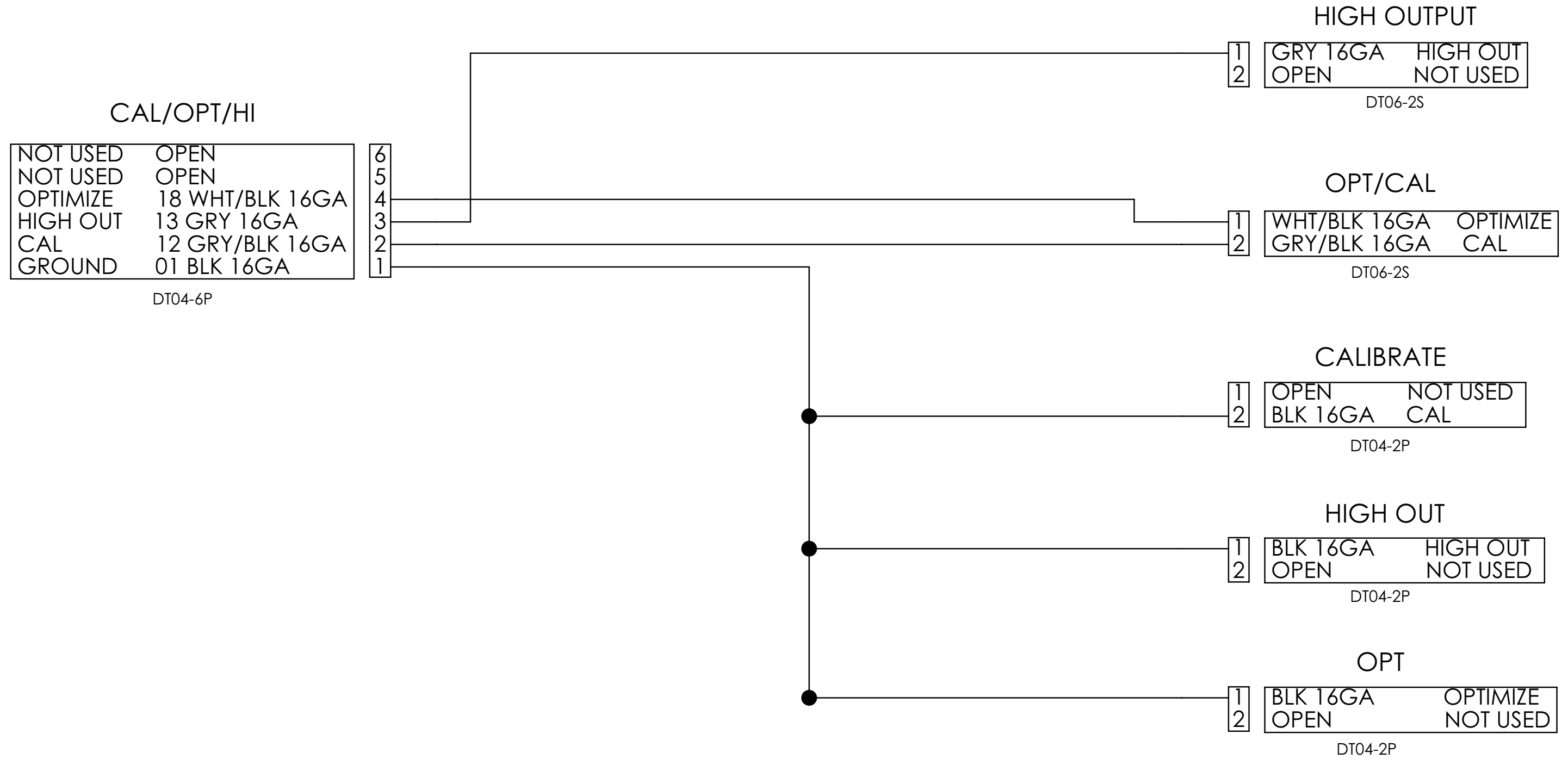

CAL / OPT / HI Harness P2P

Figure 9-5

LH Joysticks Harness

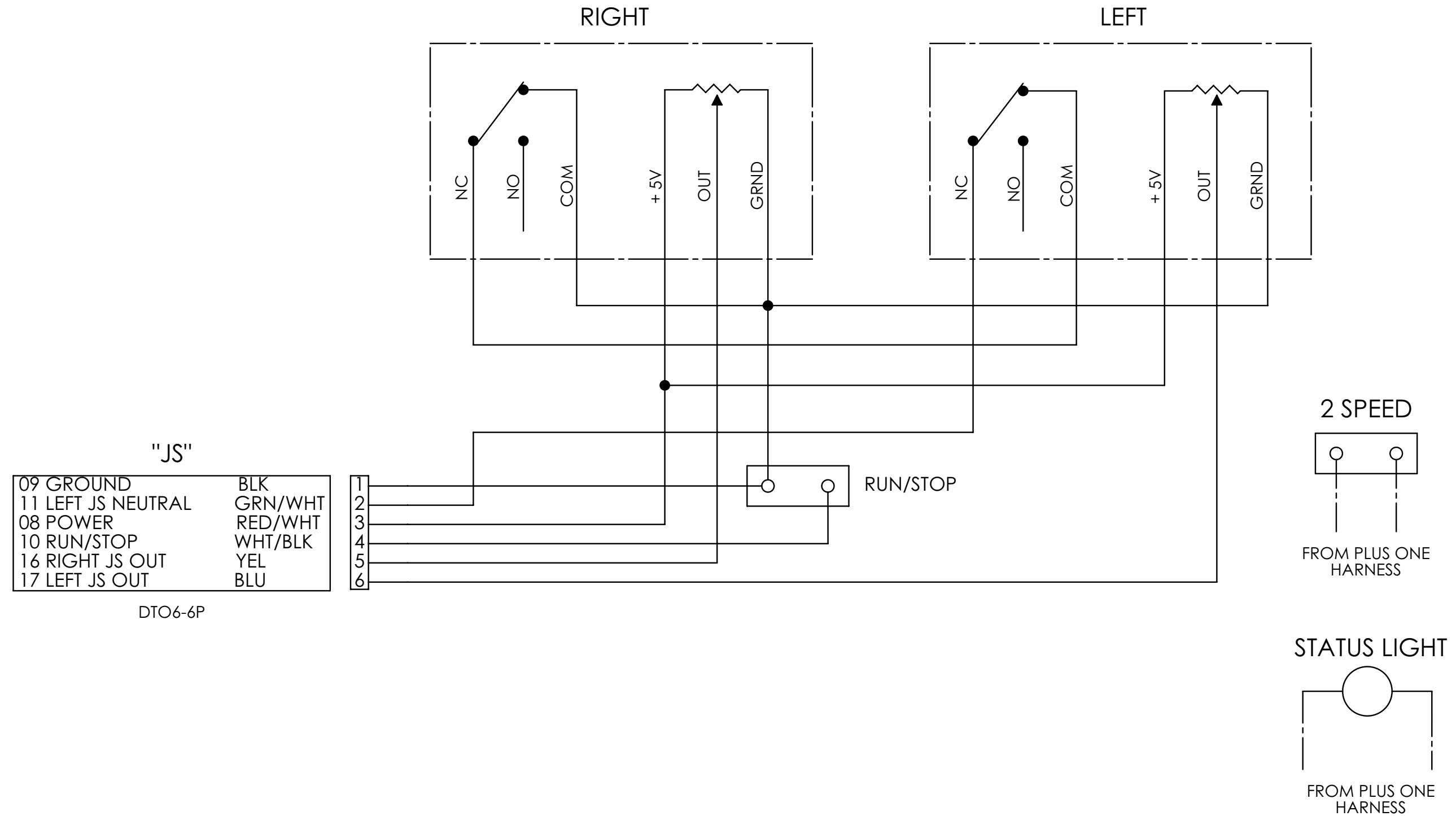

LH Joysticks Harness Layout
Figure 9-6

RH Joysticks Harness

01	BLK/YEL	AUTO POWER
02	BLU	MAN POWER
03	BRN/YEL	REMOTE BUZZER
04	BLK	REMOTE BUZZER
05	GRN	DP200 BUZZER
06	BLK	DP200 BUZZER GROUND
07	RED	E-STOP
08	GRN/WHT	F-STOP
09	RED/BLK	CUTTING EDGE UP
10	WHT	CUTTING EDGE POWER
11	YEL/RED	CUTTING EDGE DOWN
12	NOT USED	OPEN

DT04-12P

RHP1

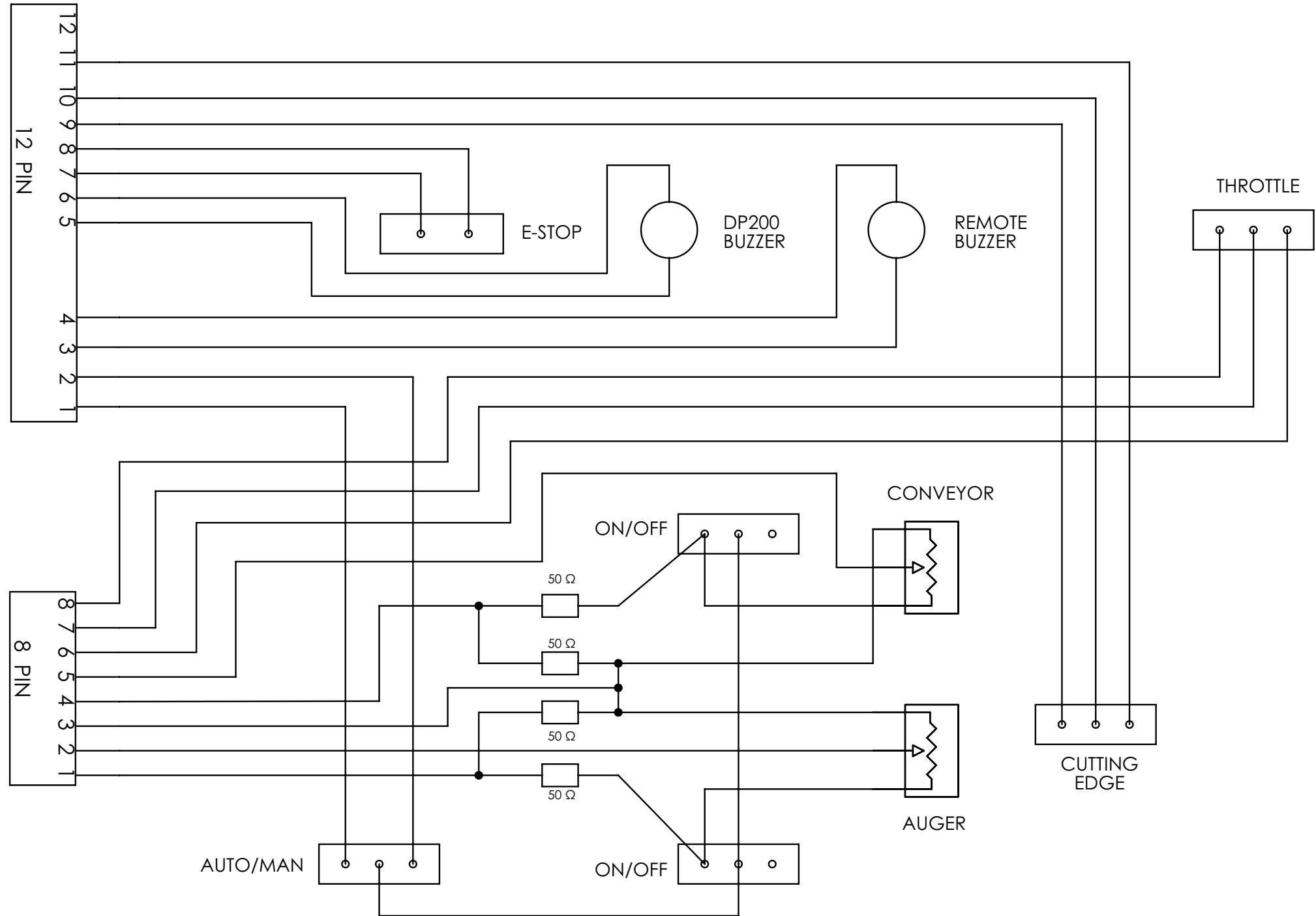

01	RED/WHT	AUGER EDC
02	RED/BLK	AUGER EDC
03	BLK	EDC GROUND
04	GRY/BLK	CONVEYOR EDC
05	GRY	CONVEYOR EDC
06	PRP/WHT	CONVEYOR EDC
07	BLK	THROTTLE
08	PRP	THROTTLE

DT06-08S

RHP2

RH Joysticks Harness Layout

Figure 9-7

Overall Harness 1 of 6

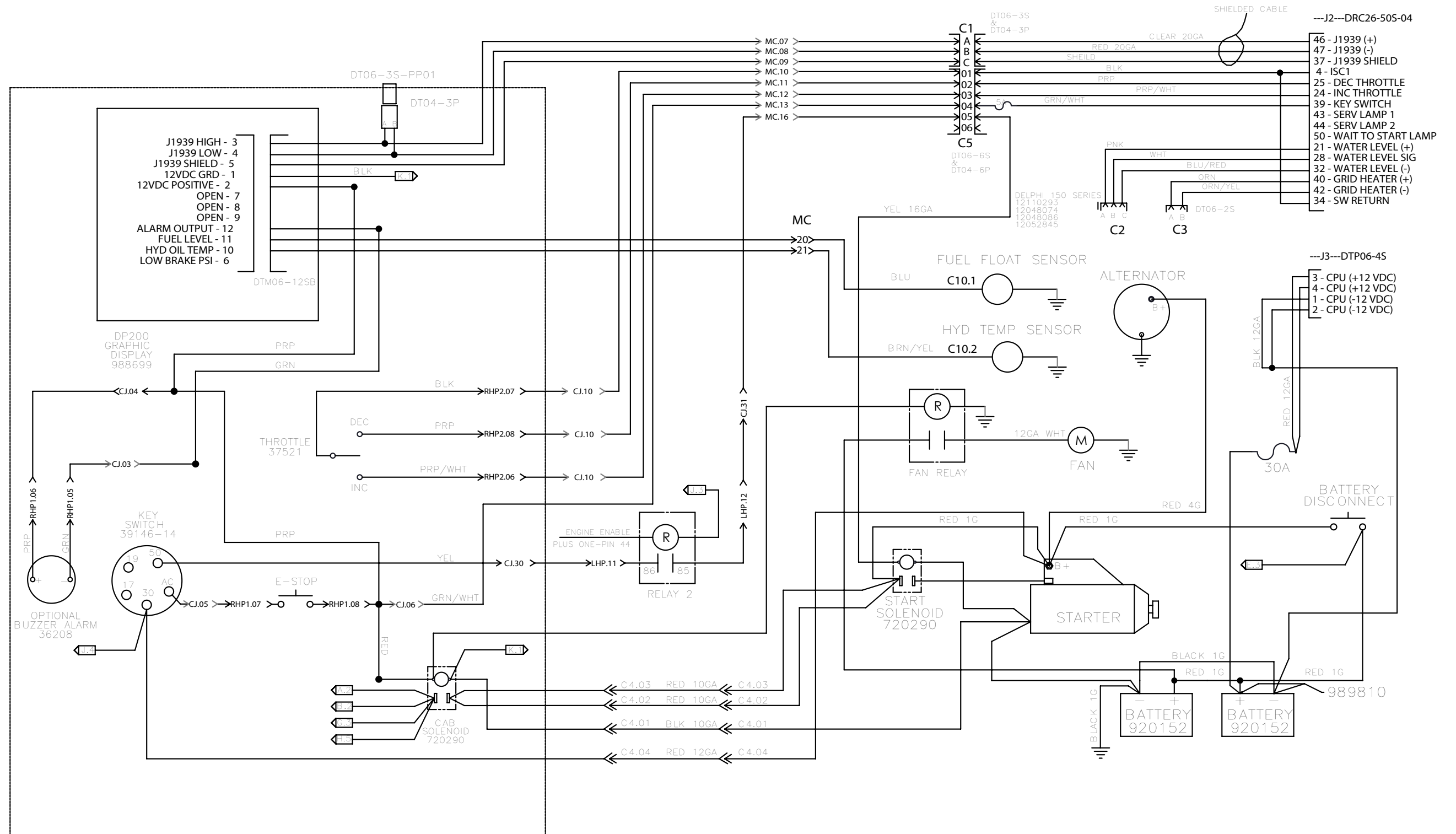

Overall Harness Layout
Figure 9-8

Overall Harness 2 of 6

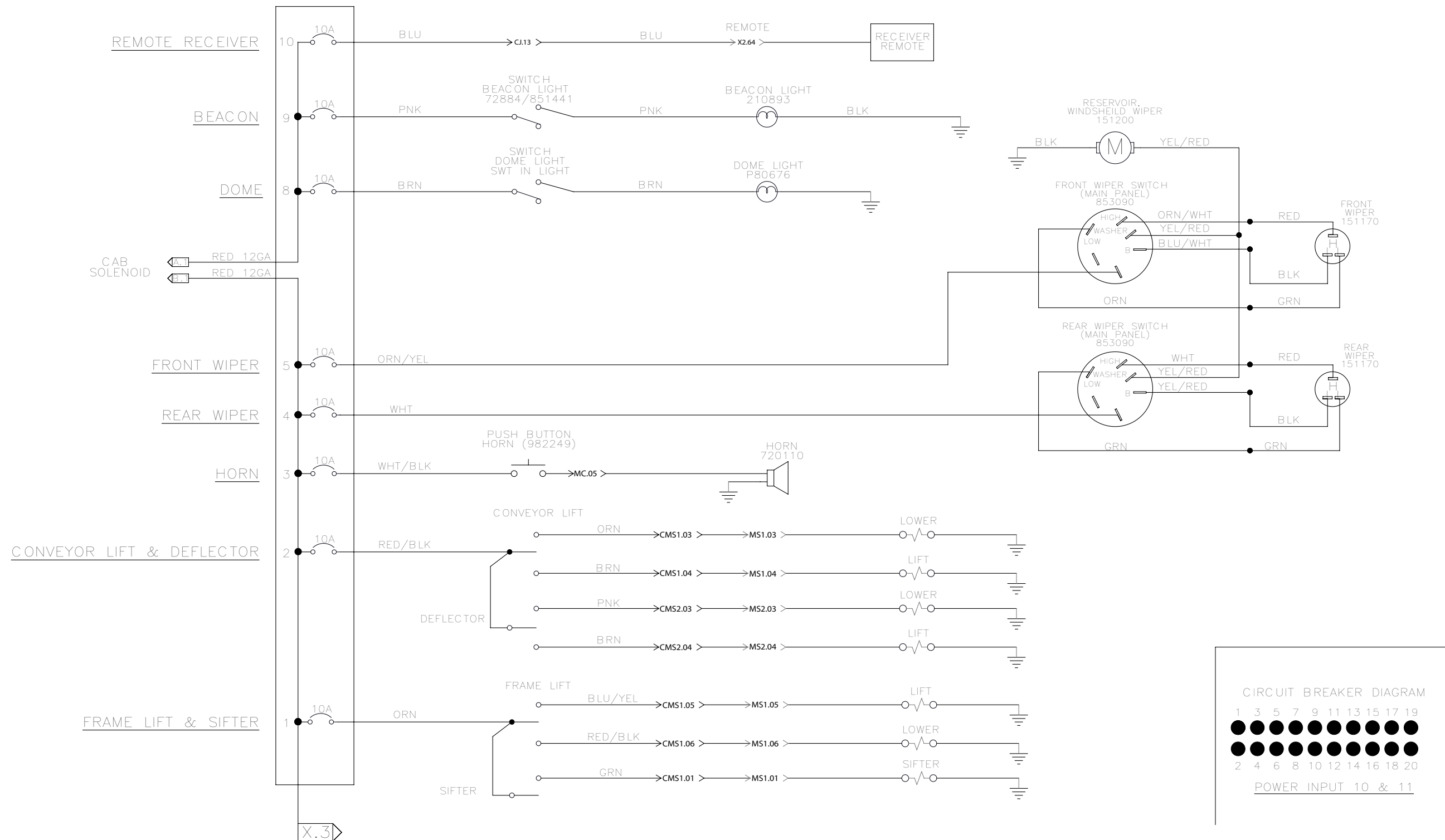

Overall Harness Layout
Figure 9-9

Overall Harness 3 of 6

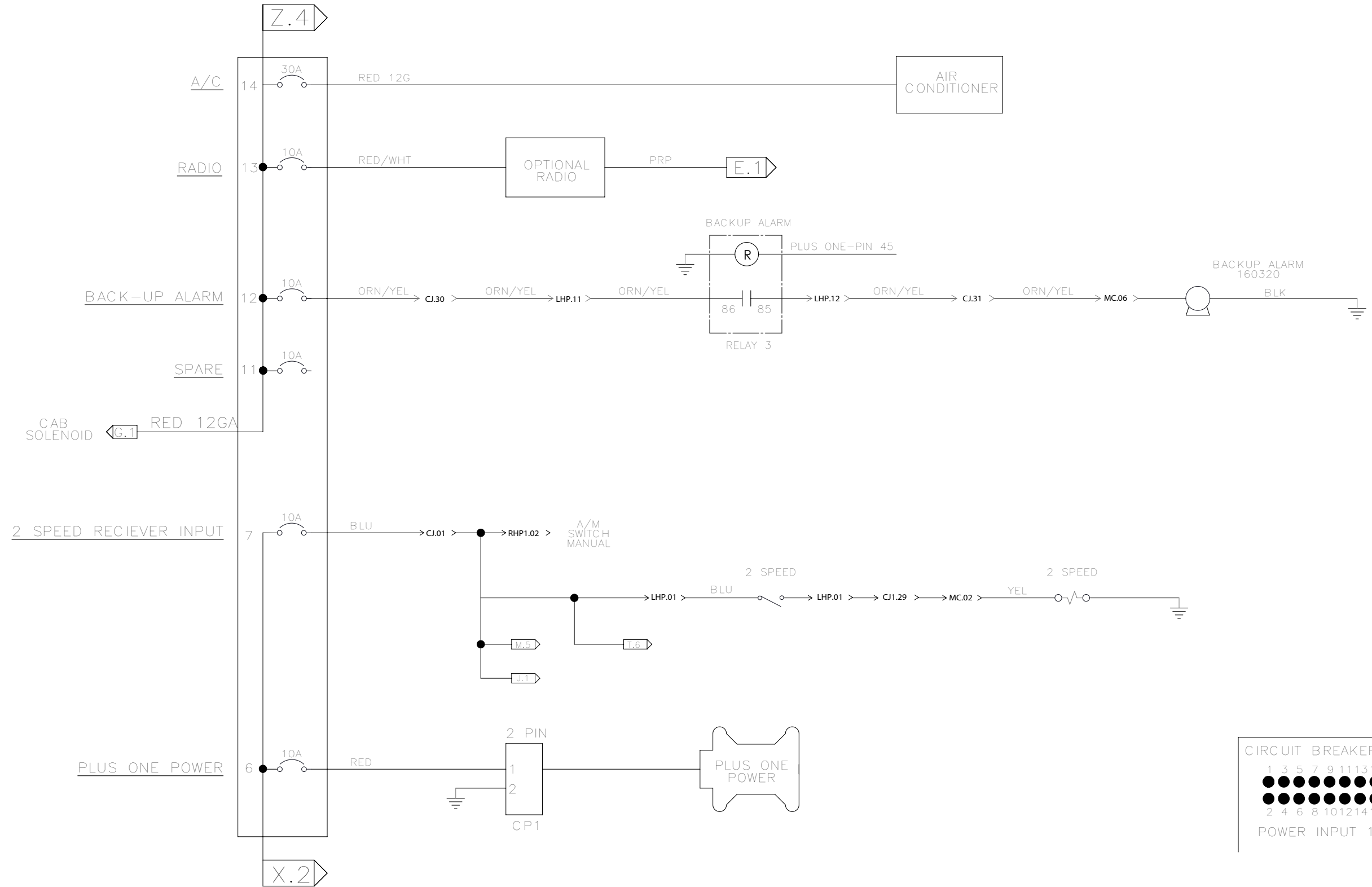

Overall Harness Layout
 Figure 9-10

Overall Harness 4 of 6

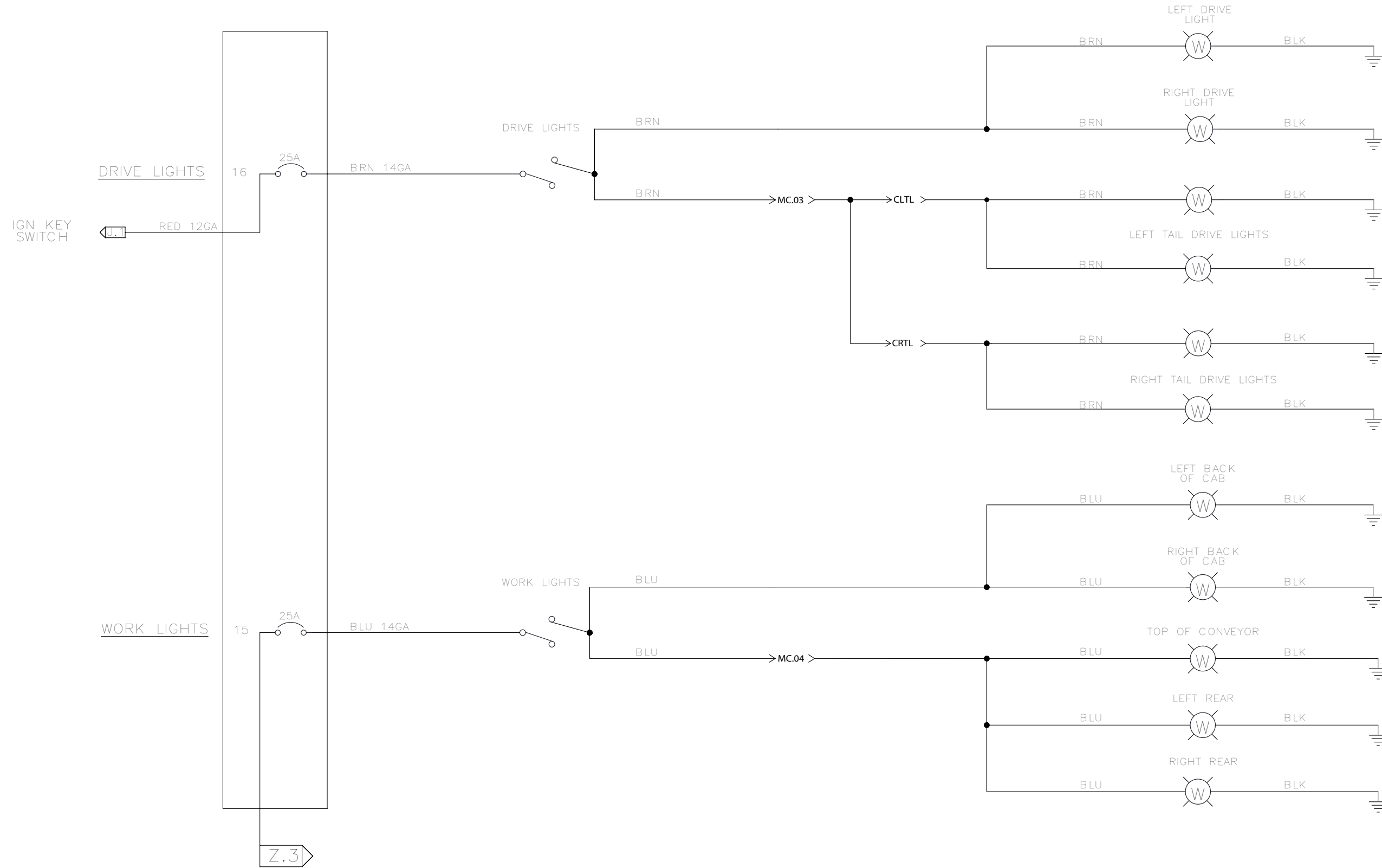

Overall Harness Layout
Figure 9-11

Overall Harness 5 of 6

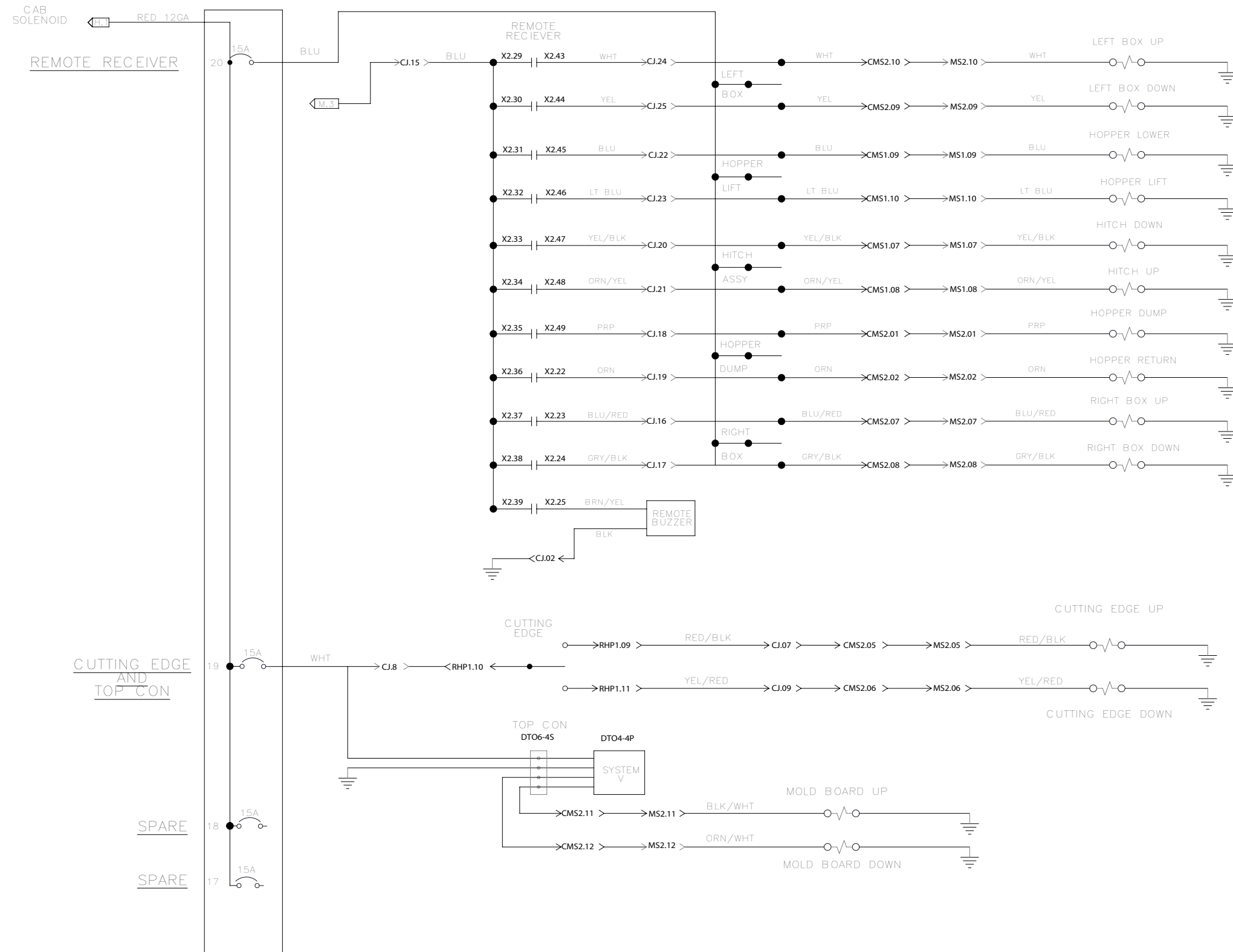

Overall Harness Layout

Figure 9-12

Overall Harness 6 of 6

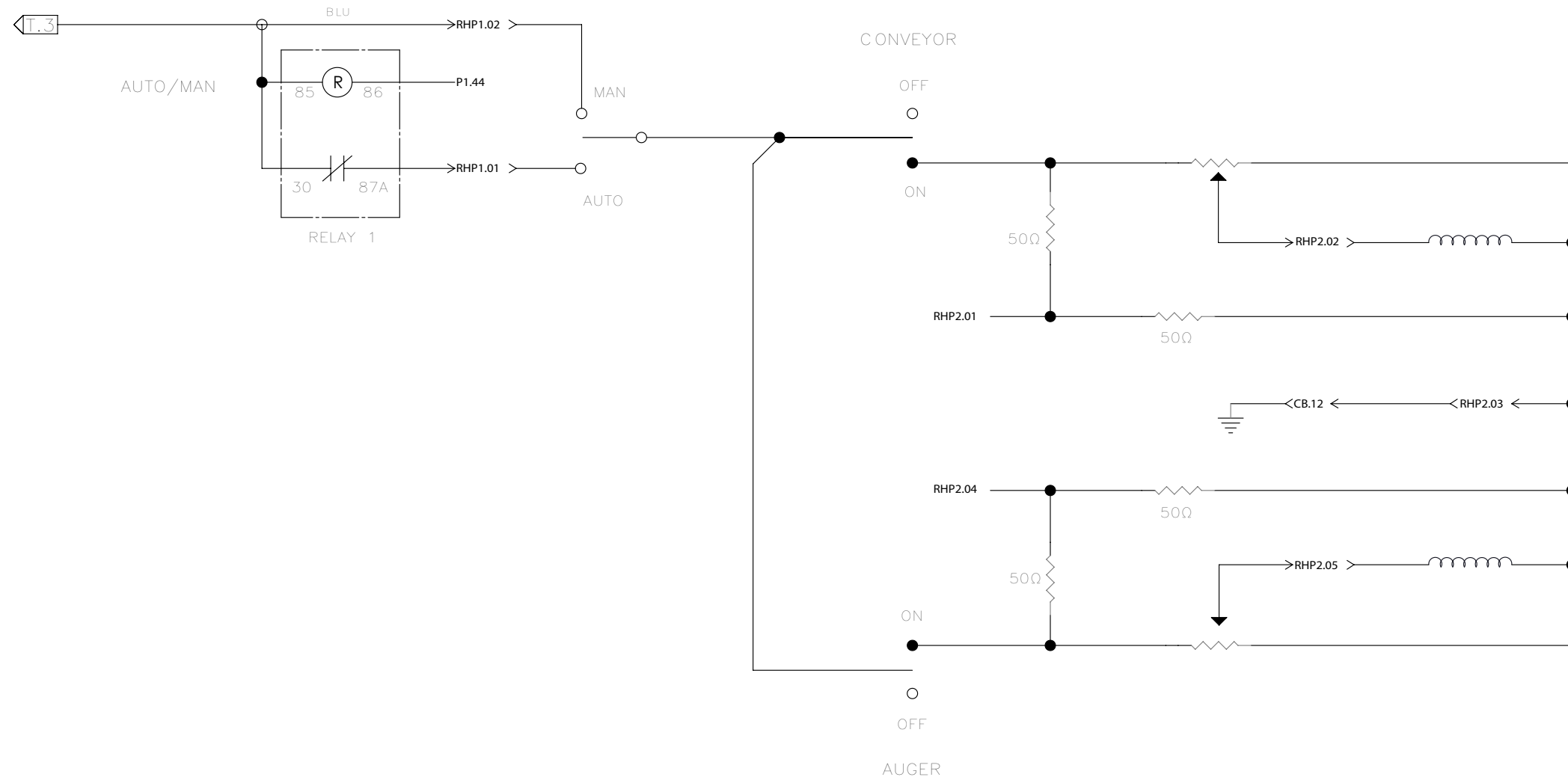

Overall Harness Layout
Figure 9-13

Main Hydraulic

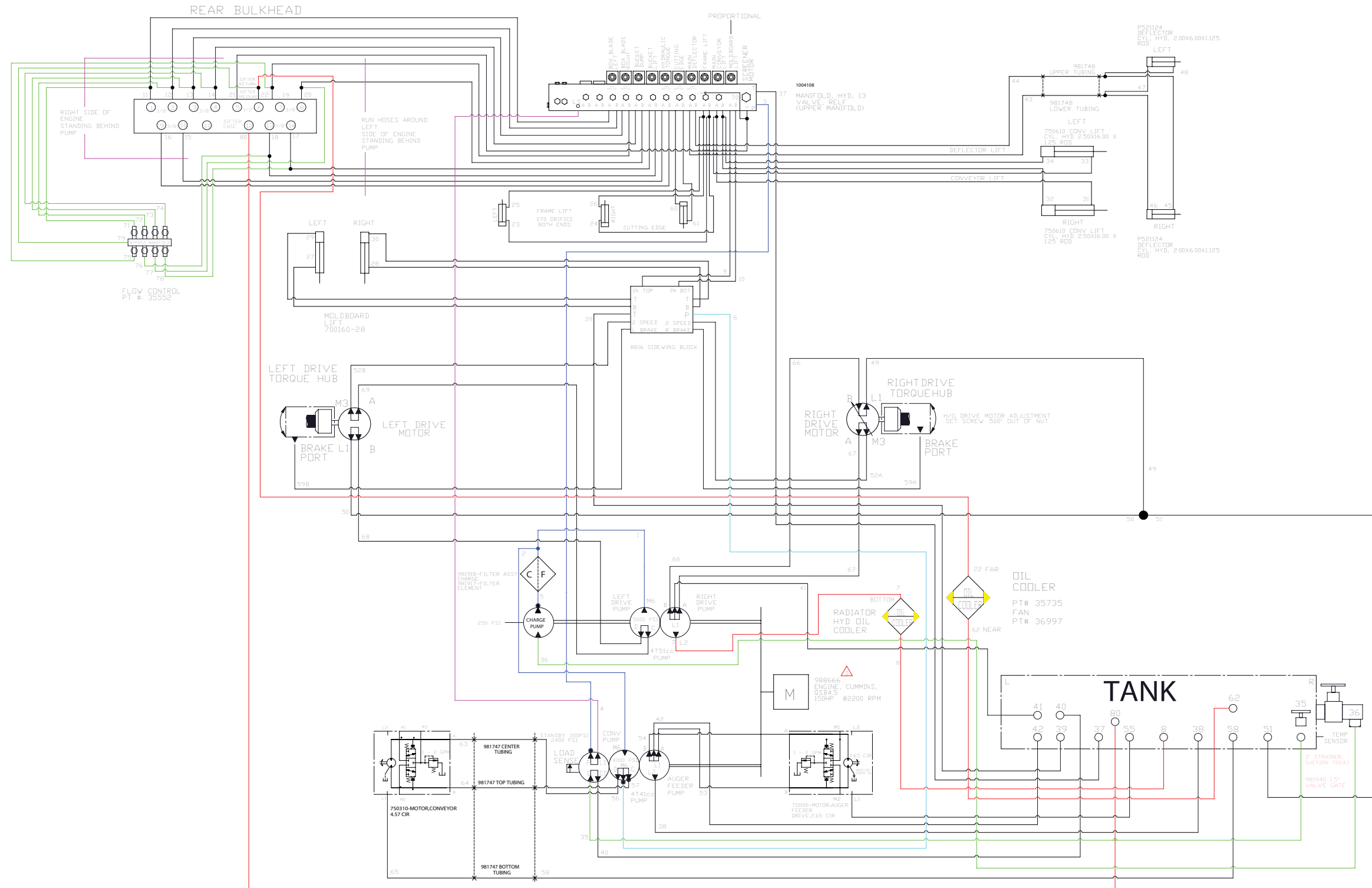

Main Hydraulic
Figure 9-14

Sand Sifter (MEV150) Hydraulic

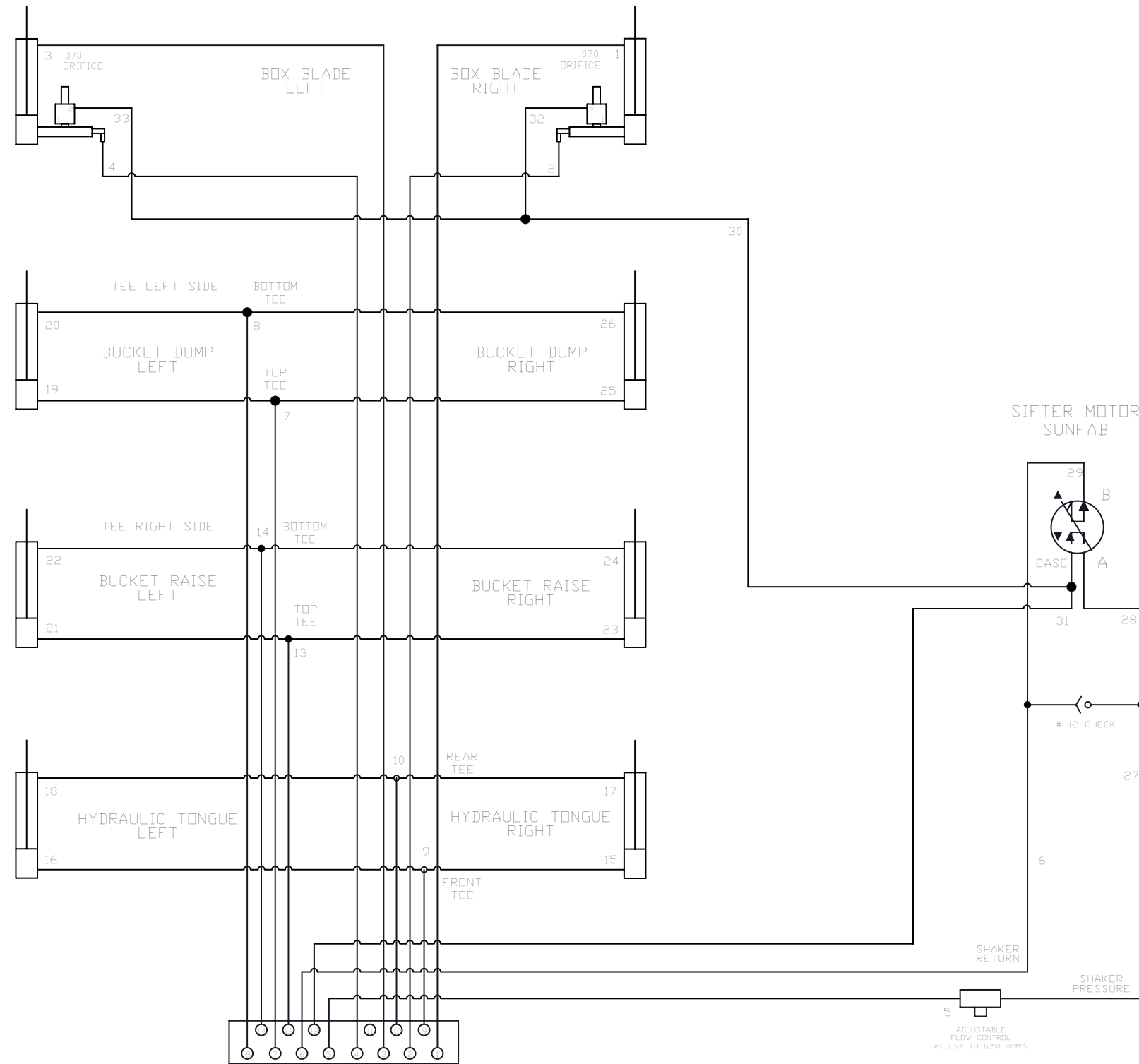

MEV150
Figure 9-15

NOTES



Section 10

ILLUSTRATED PARTS LIST (IPL)

	Page
Illustrated Parts List (IPL)	10-1
Quick Reference Guide - Filters	10-3
Quick Reference Guide - Wire Harnesses	10-3
Quick Reference Misc..	10-3
Multipurpose Moldboard	10-4
Conveyor Paddle Assembly	10-6
Track LH Assembly	10-8
Track RH Assembly	10-10
Track Group - Single Grouser	10-12
Main Frame	10-14
Hydraulic Components	10-16
Tail Pulley Group	10-18
Conveyor Assembly	10-20
Head Pulley Assembly	10-22
Head Pulley Assembly (continued)	10-24
Cab Assembly	10-26
Cab Assembly (continued)	10-28
Cab Door	10-30
Cab Components	10-32
Conveyor Controls	10-34
Switch and Indicator Panel	10-36
Right Side Control Panel	10-38
Tier III Engine and Pumps	10-40
Tier III Engine Components	10-42
Hood and Engine Access Panels	10-44
Muffler Assembly	10-46
Air Cleaner Assembly	10-48

Illustrated Parts List (IPL)



Grille and Radiator Assembly10-50
Hitch Assembly10-52
Sifter Assembly10-54
Alphabetical Parts Index10-58

Quick Reference Guide - Filters

Part Number	Description	Maint. Interval	Figure Ref.
981520	Cummins, Air Filter	250 Hours	Figure 10-21
981519	Cummins, Air Primary Filter	250 Hours	Figure 10-21
981937	Cummins, In-line Filter	250 Hours	Figure 10-21
34881	Cummins, Oil Filter	250 Hours	Figure 10-18
72078	Cummins, Fuel Secondary Filter	250 Hours	Figure 10-18
34883	Cummins, Fuel Primary Filter	250 Hours	Figure 10-18
72243	Hydraulic, Suction Strainer - 2 Required	250 Hours	Figure 10-9
980560	Hydraulic, Suction Strainer	250 Hours	Figure 10-9
981917	Hydraulic, Element Charge	250 Hours	Figure 10-9
36123	Suction, Strainer	--	--

Quick Reference Guide - Wire Harnesses

Part Number	Description	Figure Ref.
1003905	Harness,Main,3000SS	
1004666	Harness, Cab Harness	Figure 9-4
1003851	Harness, Plus One	Figure 9-5
1004561	Harness, Manifold	Figure 9-7
1004560	Harness,Cal/Opt, hi output	Figure 9-9
36123	Strainer,Hyd Suction,200 Mesh	
1004562	LH Joysticks Harness	
1004563	RH Joysticks Harness	
1004567	Overall Harness 1 of 6	
1004567	Overall Harness 2 of 6	
1004567	Overall Harness 3 of 6	
1004567	Overall Harness 4 of 6	
1004567	Overall Harness 5 of 6	
1004567	Overall Harness 6 of 6	
1004570	Main Hydraulics	
1004571	Sand Sifter (MEV150) Hydraulics	

Quick Reference Misc.

Part Number	Description
1005696	Kit, Decal, 3000SS

Multipurpose Moldboard

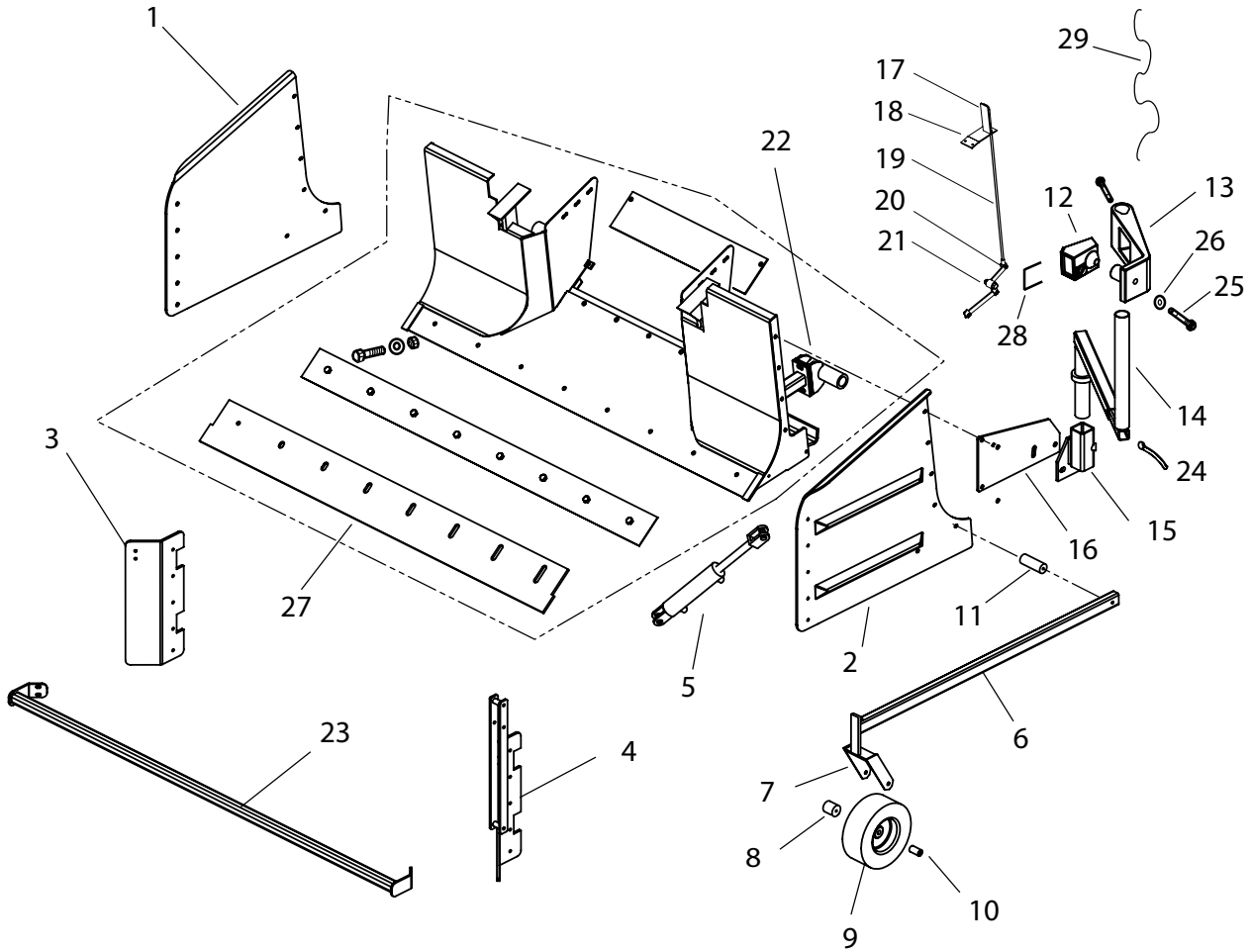

Figure 10-1

Multipurpose Moldboard Parts List

Item No.	Part Number	Qty.	Description	Remarks
1	1004702	1	W/M,Auger Box Side, RH	
2	1004701	1	W/M,Auger Box Side, LH	
3	1004726	1	Plate,Moldboard Widener,RH	
4	1004730	1	W/M,Widener With Guide Brkt,LH	
5	700160-28	1	Cyl,Hyd,3.50X10.00X1.75 Rod	
6	1004378	1	Tubing,Guide Wheel	
7	1004373	1	Assy, Axle Pivot Guide Wheel	
8	1004438	1	Spacer, Guide Wheel	
9	1004372	1	Wheel, Guide Wheel	
10	1004439	1	Spacer, Guide Wheel	
11	1004724	1	Spacer,Guide Wheel Assy	
12	983414-01	1	TSD Sonic Tracker II	
13	851578	1	Bracket,Sonic Tracker,Topcon	
14	9090-1125SRV	1	Bracket Z Arm TOPCON	
15	851575SRV	1	Pivot Mount, TOPCON/Spectra	
16	851575SRV	1	Bracket,Sonic Tracker,TOPCON	
17	1004487	1	Plate,Decal Plate	
18	1004486	1	Plate,Cutting Edge Gauge,Top	
19	1004485	1	Rod,Cutting Edge Gauge	
20	920080	1	Ball Joint,.250,Female	
21	1004054	1	W/M,Lever Height Gauge	
22	982765	1	Mount Block Assembly Pivot	
23	1004790	1	W/M,Moldboard Tension Bar	
24	300060	1	Handle Nut,.625-11	
25	102-617-1A	1	CSHH,.625-11X4.00,GR5 Cap Screw, 5/8-11 X 4.00 Hex	
26	119-7	1	Washer,Flat,SAE,.625 Flat	
27	1003910SRV	1	Weldment,Cutting Edge	
28	983414-10	1	Assy, Temp Bail W/Sleeves	
29	1004565	1	Harness, TOPCON, Curly Cord, Modified, Sand Shark	
30	1004430	1	Wearplate,Plastic,Sand Shark Cutting Edge	
31	1004616	1	Kit,Bolt Cutting Edge	

Conveyor Paddle Assembly

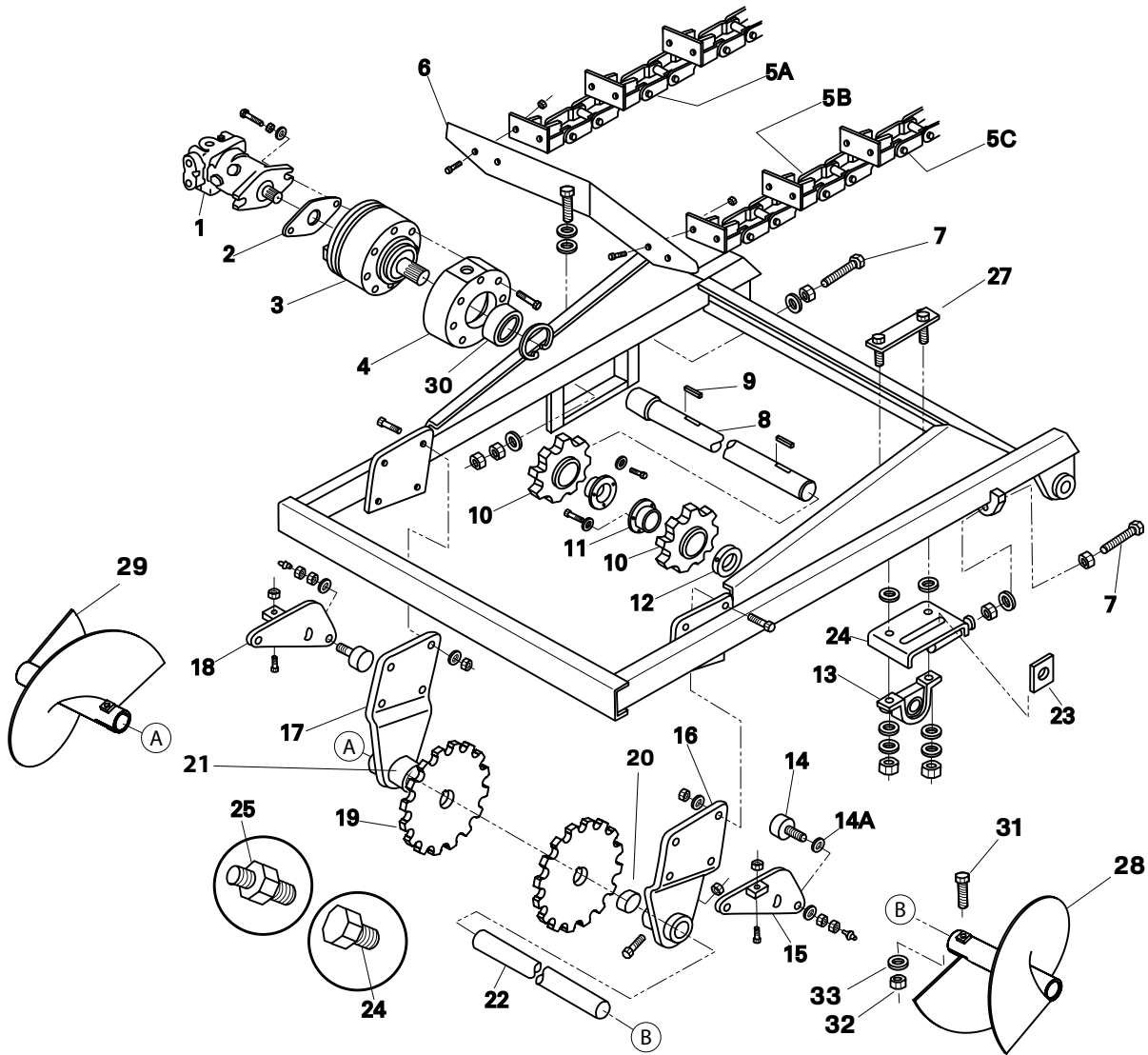

Figure 10-2

Conveyor Paddle Assembly Parts List

Item No.	Part Number	Qty.	Description	Remarks
1	710100	1	Hyd. Motor, Feeder Drive, 3000	
2	700480	1	Gasket, S.A.E. B" 2 Bolt "	
3	710090-28	1	Torque Hub, Feeder Drive	
4	854932	1	Mount, Torque Hub	
5	A710230	A/R	Chain Assy., Feeder	
5A	710230L556	A/R	Chain Assy., Feeder L.H.(Paddle)	
5B	710230R556	A/R	Chain Assy., Feeder R.H. (Paddle)	
5C	710230-1	A/R	Link & Pin Assy., Feeder Chain (2800/3000)	
6	710240556	A/R	Blade Paddle, 2800 / 3000 Feeder	
7	750549SRV	1	Rod, Paddle Chain Adjuster	
8	710171A	1	Shaft, 3000 Feeder Upper Drive	
9	710171-2	1	Keyway, Paddle Conveyor	
10	710182	2	Sprocket, Feeder Chain Upper Paddle Dr	(9 Tooth)
11	710150-28	2	Taper Lock Bushing, 2 1/2 "	
12	120120	2	Locking Collar, 2-1/2 I.D. "	
13	710160-28R	1	Bearing, Conveyor Head Pulley R.H. (2800)	
14	811316	2	Cam Follower, 3-1/4 "	
14A	854953	1	Paddle Roller Spacer / 3000	
15	750550	1	Assy. Paddle Beaing, Adj. L.H.	
16	750551SRV	1	Assy, Padde Shaft --- L.H.	
17	750553SRV	1	Assy. Paddle Shaft, Adj. R.H.	
18	750552	1	Assy. Paddle Beaing, Adj. R.H.	
19	855066	2	Sprocket, 3000 Feeder Chain Lower (Paddle)	
20	210240	2	Seal	
21	710183	2	Bushing, Lower Feeder Shaft (Bronze)	
22	710221A	1	Shaft, 3000 Feeder Lower	
23	854955	1	Paddle Shaft Stop	
24	854933	1	Paddle, Motor Mount Slide	
25	140610		Grease Fitting, 1/4" X 28 Screw In	
27	854946A	1	Paddle Bearing Plate	
28	W522855	1	Auger (Snow) L/H - P/S Only	
29	W522854	1	Auger (Snow) R/H - P/S Only	
30	520100		Bearing Insert 3.00 / 400 Stub Axle / 3000	
31	984138		Bolt 1" x 8	
32	80009		Nut 1"	
33	119-10		Washer 1"	

Track LH Assembly

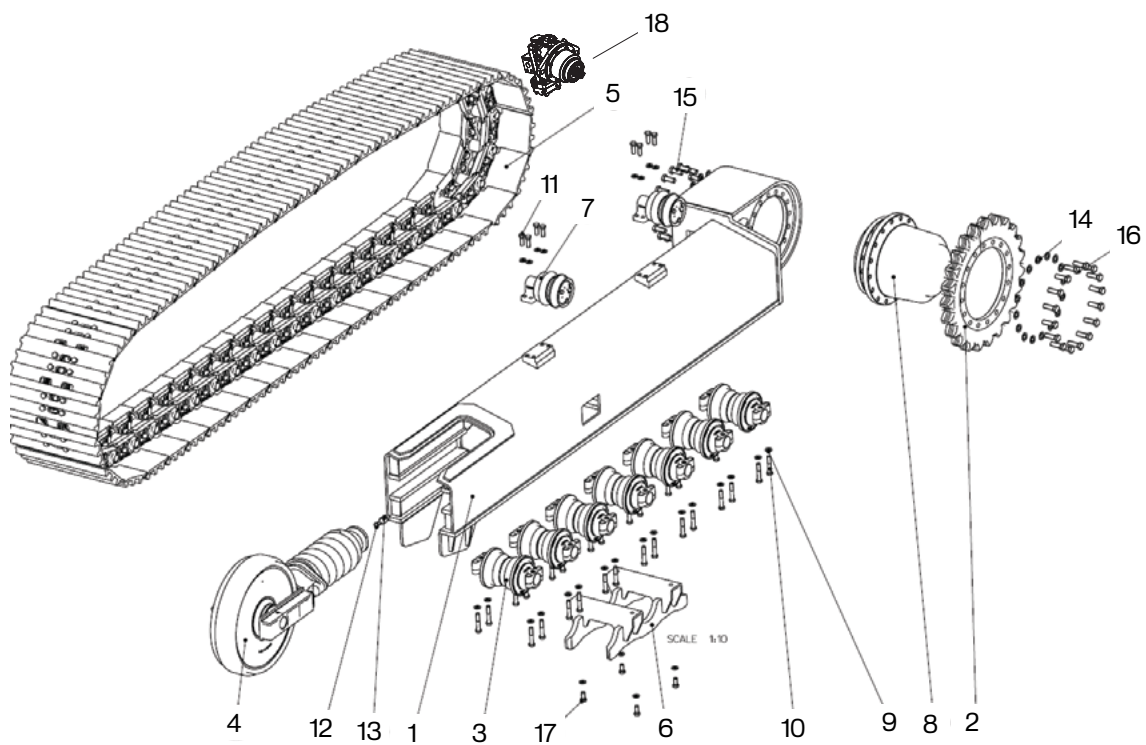

Figure 10-3

Track LH Assembly Parts List

Item No.	Part Number	Qty.	Description	Remarks
1		1	LH side frame	Reference Only
2	1004426-01	1	Sprocket	
3	1004426-02	7	Track roller	
4	1004426-03	1	Idler with track adjuster	
5	CR5985/46/500	1	Track chain assembly	
–	CR6096/46/500	1	Alternative 1-Bar TGA	
6	1004426-04	1	Rock guard	
7	1004426-05	2	Top Roller	
8	1004426-06	1	Drive unit	
9	1004426-07	40	Washer	
10	1004426-08	28	Bolt	
11	1004426-09	8	Bolt	
12	1004426-10	1	Washer	
13	1004426-11	1	Valve	
14	1004426-12	32	Washer	
15	1004426-13	16	Bolt	
16	1004426-14	16	Bolt	
17	1004426-15	4	Bolt	
18	989183	1	Motor, Drive 18T	

Track RH Assembly

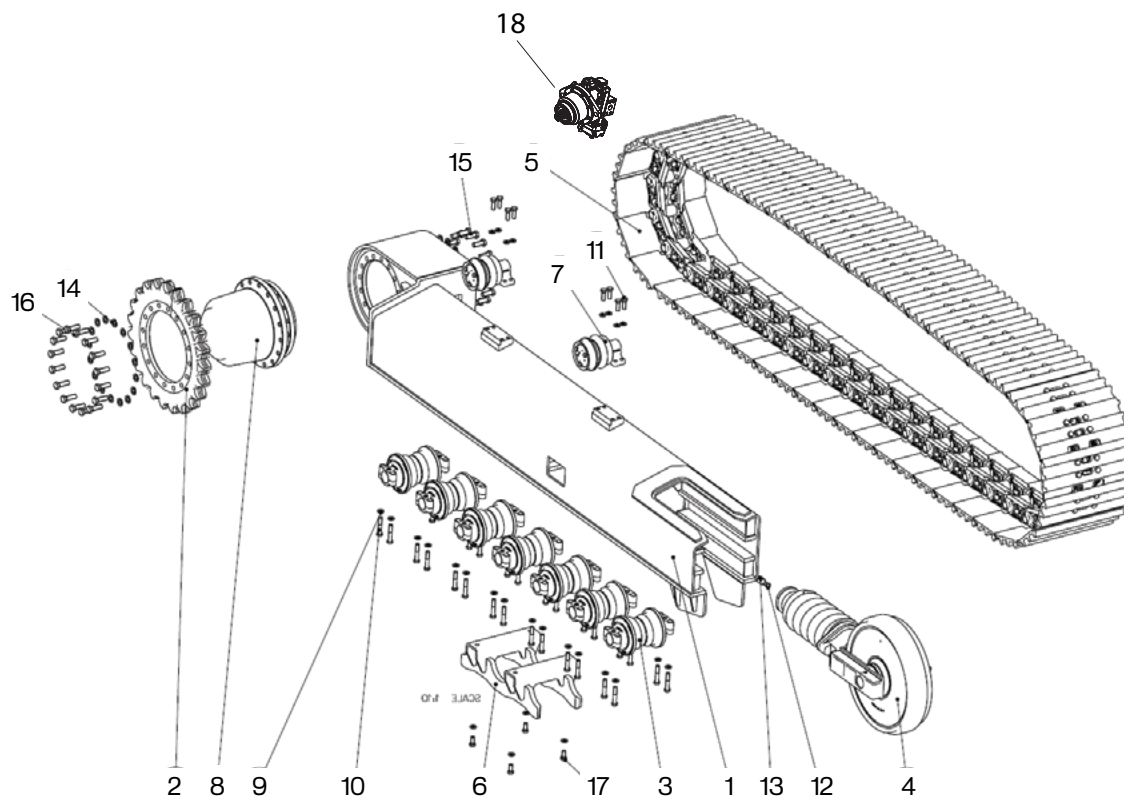

Figure 10-4

Track RH Assembly Parts List

Item No.	Part Number	Qty.	Description	Remarks
1		1	RH side frame	Reference Only
2	1004426-01	1	Sprocket	
3	1004426-02	7	Track roller	
4	1004426-03	1	Idler with track adjuster	
5	CR5985/46/500	1	Track chain assembly	
–	CR6096/46/500	1	Alternative 1-Bar TGA	
6	1004426-04	1	Rock guard	
7	1004426-05	2	Top Roller	
8	1004426-06	1	Drive unit	
9	1004426-07	40	Washer	
10	1004426-08	28	Bolt	
11	1004426-09	8	Bolt	
12	1004426-10	1	Washer	
13	1004426-11	1	Valve	
14	1004426-12	32	Washer	
15	1004426-13	16	Bolt	
16	1004426-14	16	Bolt	
17	1004426-15	4	Bolt	
18	989183	1	Motor, Drive 18T	

Track Group - Single Grouser

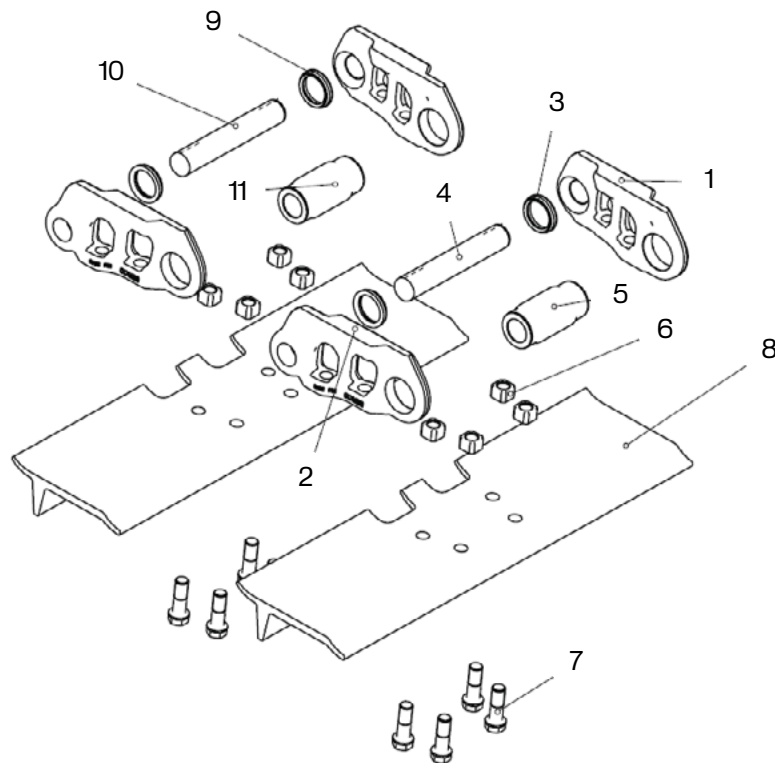

Figure 10-5

Track Group - Single Grouser Parts List

Item No.	Part Number	Qty.	Description	Remarks
1	1004426-16	46	Track link LH	
2	1004426-17	46	Track link RH	
3	1004426-18	90	Polyurethane Seal	
4	1004426-19	45	Track Pin	
5	1004426-20	45	Track bushing	
6	1004426-21	184	Track Shoe Nut	
7	1004426-22	184	Track Shoe Bolt	
8	1004426-23	46	Track Shoe 500mm wide	
9	1004426-24	2	Spacer	
10	1004426-25	1	Track Pin Master	
11	1004426-26	1	Master Bushing	

Main Frame

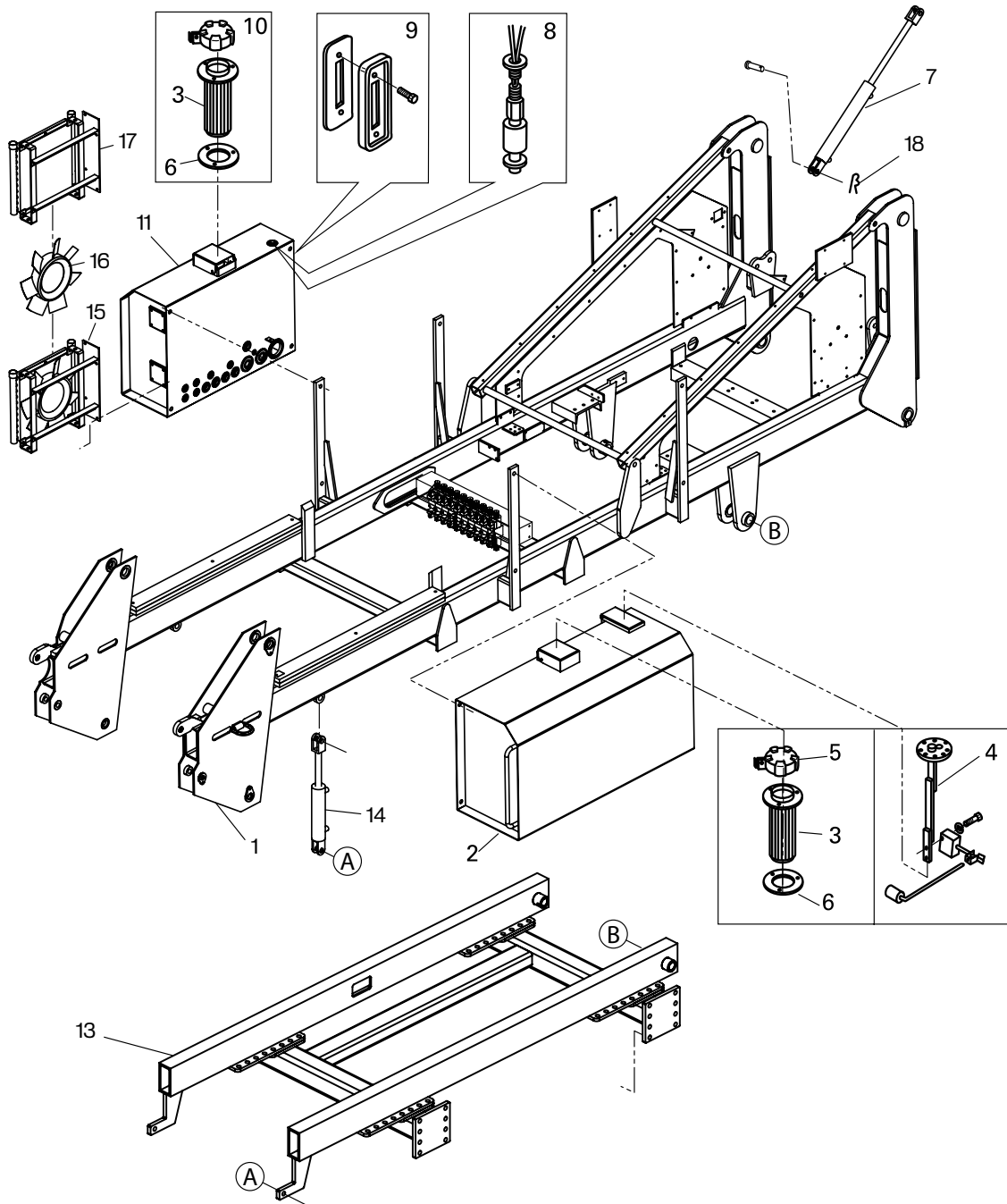

Figure 10-6

Main Frame Parts List

Item No.	Part Number	Qty.	Description	Remarks
1	1003826	1	W/M Main Frame, 3000SS	
2	1004253	1	Group, Tank. Fuel	
3	140030FN	1	Filler Neck, Hyd. Oil / Fuel Cap	Not Shown
4	140040	1	Sending Unit, Fuel Level	
5	140030FL	1	Fuel Tank Cap, Lockable	
6	140030GK	1	Strainer & Gasket Kit, Hyd./ Fuel Filler	
7	750610	2	Cylinder, Hydraulic	
–	38550-01	A/R	CylinderSeal Kit	
8	981357	1	Switch, Low Hyd. Oil Level	
9	500070	1	Gauge, Hyd. Oil Level & Temp.	
10	140030HL	1	Cap, Hyd. Oil Tank (Lockable)	
11	1004370	1	Group, Tank, Hydraulic	
12	35368	1	Sender, Temperature Gauge	
13	1003828	1	Assy, Under Carriage Bracing	
14	37293	2	Hydraulic Cylinder	Frame Lift
–	37620-05	A/R	CylinderSeal Kit	
15	1000516	1	Cooler, Oil Assembly	
16	36997	1	Cooler, Fan Only	
17	35735	1	Cooler, Oil	
18	81019	1	Pin,Cotter,.156X2.50	

Hydraulic Components

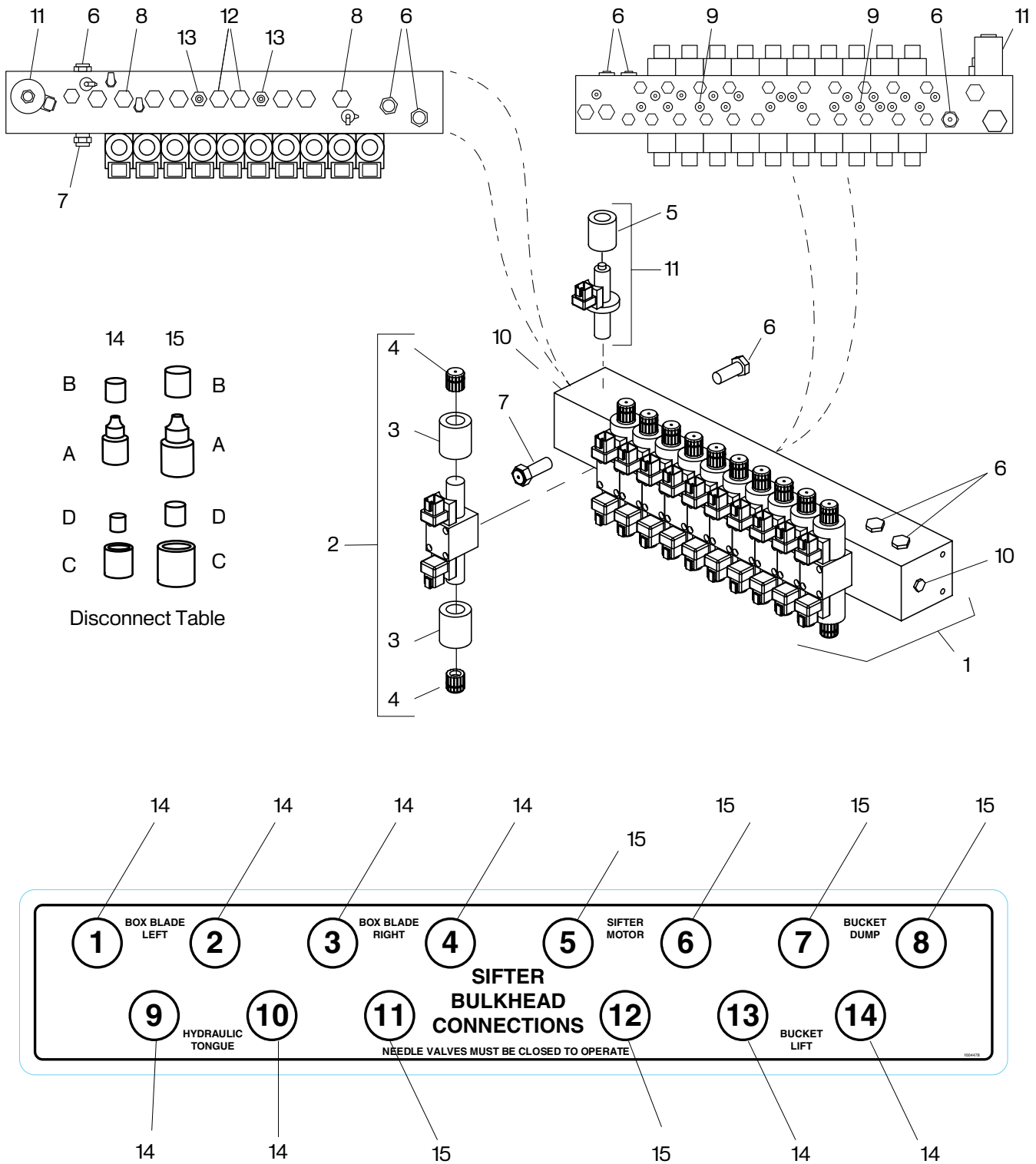

Figure 10-7

Hydraulic Components Parts List

Item No.	Part Number	Qty.	Description	Remarks
1	1004108	1	Manifold, Hyd 13 station Sand Shark	
2	983643-01	1	Solenoid Valve	
3	983643-02A	18	Coil, 12 VDC	
4	983643-03	20	Nut, Coil	
5	1004108-03	1	Valve, Reducing CP08-30	
6	987220-05	4	Plug, CP08-20	
7	983643-04	-	CP10-24	
8	983643-05	9	Valve, Dual Check	
9	983643-08	27	Valve, Check	
10	983643-10	1	Flow Divider CP10-4L	
11	720290	1	Solenoid Valve SV12-28	
12	986992-03	2	Valve, Check PC10-30	
13	987220-07	2	Valve, Counterbalance CBCA-LNN	
-	983643-11	A/R	Cover Plate, Valve	Not Shown
-	987220-01	A/R	Plug	Not Shown
-	987220-02	A/R	Plug	Not Shown
-	987220-03	A/R	Valve, Check	Not Shown
-	988657-01	A/R	Valve, Check	Not Shown
-	980286	1	Plate, Hydraulic Output	Not Shown
-	1004108-02	1	Solenoid Valve	
14A	1004607	8	3/8" Male Hydraulic Quick Disconnect	
14B	1004609	8	3/8" Male Hydraulic Quick Disconnect Cap	
14C	1004608	8	3/8" Female Hydraulic Quick Disconnect	
14D	1004610	8	3/8" Female Hydraulic Quick Disconnect Cap	
15A	1004611	6	1/2" Male Hydraulic Quick Disconnect	
15B	1004613	6	1/2" Male Hydraulic Quick Disconnect Cap	
15C	1004612	6	1/2" Female Hydraulic Quick Disconnect	
15D	1004614	6	1/2" Female Hydraulic Quick Disconnect Cap	

Tail Pulley Group

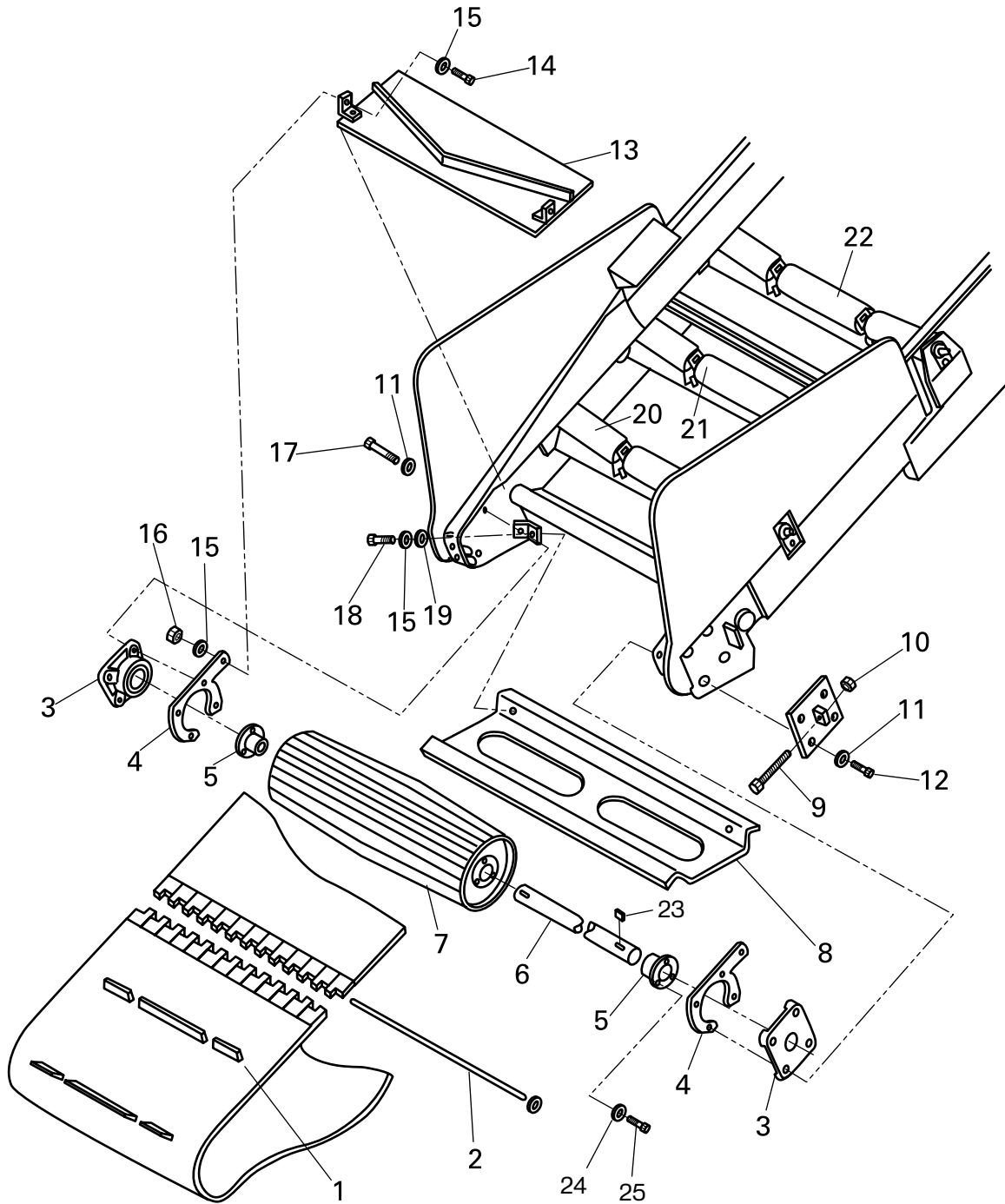

Figure 10-8

Tail Pulley Group Parts List

Item No.	Part Number	Qty.	Description	Remarks
1	P202014	1	Conveyor Belt W / Cleats, 28' Frame	
1A	P202014-01	1	Kit, Lacing Repair	
2	750080	A/R	Pin, Conveyor Belt Lacing (30") W/O Metal Tips	For 3000 Loader Only
3	750040	2	Bearing, 2800 / 3000 Conveyor Tail Pulley	
4	750052	2	Bracket, Tail Pulley Bearing Adjustment	
5	750050	2	Bushing, 2800 / 3000 Conveyor Tail Pulley	
6	750032	1	Shaft, 3000 Main Conveyor Tail Pulley	
7	750060	1	Tail Pulley, Winged 2800/3000	10.50 X 32 "
8	750061	1	Burn Out Guard, 3000 Tail Pulley	
9	W520862	2	Bolt, Conveyor Adjusting	
10	116-8	2	Nut, 3/4-10 Hex "	
11	118-7	8	Washer, 5/8 Lock "	
12	102-611-1A	4	Cap Screw, 5/8-11 X 2-1/2 Hex "	
13	750062	1	Scraper, 3000 Tail Pulley	
14	102-207-1A	2	Cap Screw, 3/8-16 X 1-1/2 Hex "	
15	119-3	4	Washer, 3/8 Sae Flat "	
16	143-3	2	Lock Nut, 3/8-16 Hex "	
17	102-609-1A	4	Cap Screw, 5/8-11 X 2 Hex "	
18	102-206-1A	4	Cap Screw, 3/8-16 X 1-1/4 Hex "	
19	118-3	4	Washer, 3/8 Lock "	
20	750131	1	Roller Assy(15 Degree), Conveyor Troughing	
21	750130	2	Roller Assy (30 Degree), Conveyor Troughing	
22	986341	9	Roller Assy.(25 Degree), Conveyor Troughing	
23	857137	2	Keystock,Sq.,.375X1.75	
24	118-3	6	Washer,Lock,.,375	
25	102-207-1A	6	CSHH,.,375-16X1.50,GR5	

Conveyor Assembly

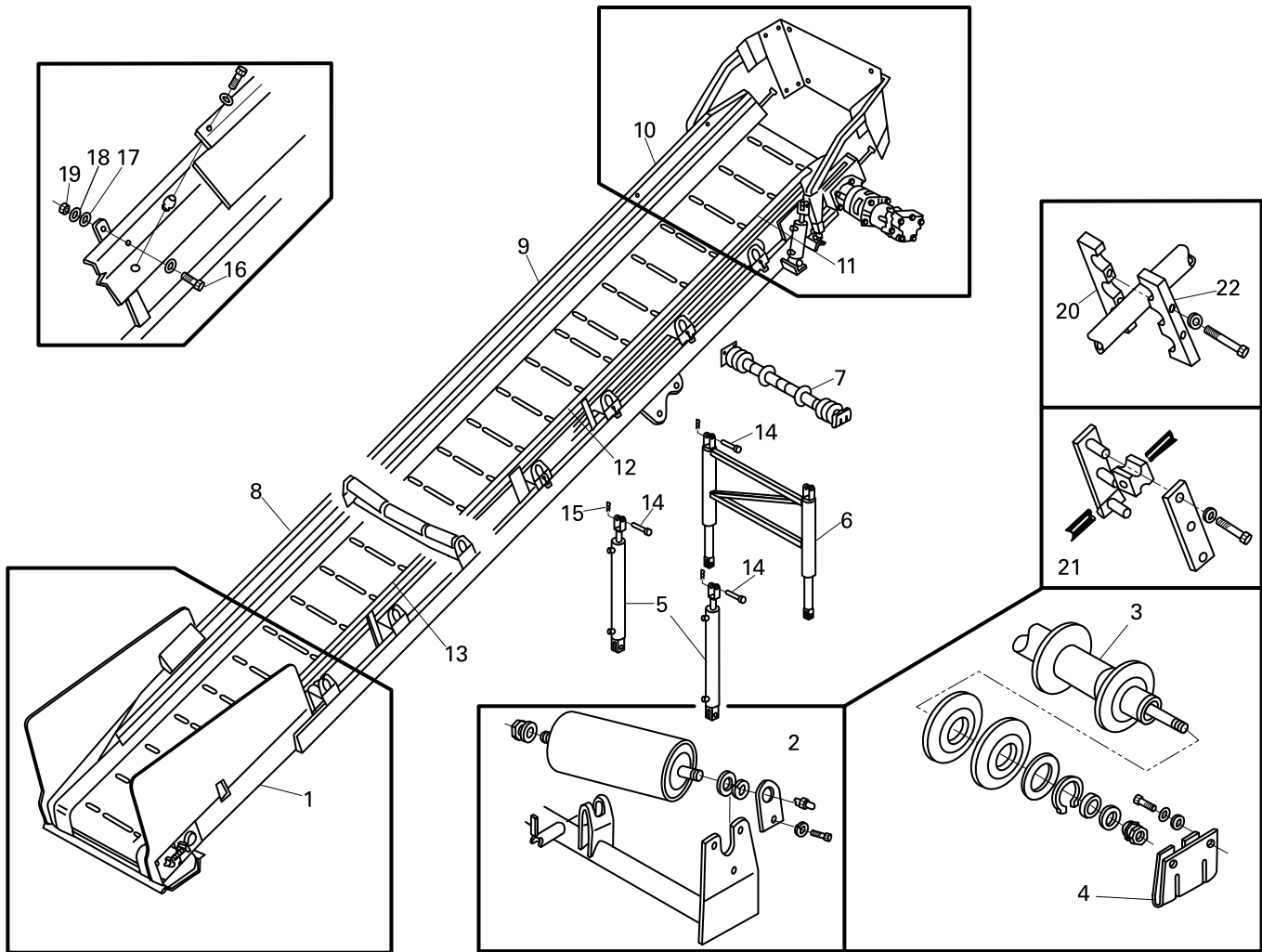

Figure 10-9

Conveyor Assembly Parts List

Item No.	Part Number	Qty.	Description	Remarks
1	981386	1	Complete Assembly	
2	750140	A/R	Roller, 2800 / 3000 Troughing Idler	
3	750090	A/R	Roller Assy., Conveyor Return Idler	
4	854741	2	J. Bracket Main Conveyor	
5	750610	2	Conveyor Lift Cylinder	
6	981438	1	Conveyor Stabilizer	
7	750090	3	Roller Assy., Conveyor Return Idler	
8	854795	1	Side Plate, Front Right	
9	854799	1	Side Plate, Center Right	
10	854797	1	Side Plate, Back Right Side	
11	854801	1	Side Plate, Back Left Side	
12	854798	1	Side Plate, Center Left Side	
13	854796	1	Side Plate, Front Left Side	
14	1000284	4	Cyl. Clevis 1.00X 2.75	
15	870307	4	Clip, Hyd Cyl. Pin *	
16	102-405-1A	A/R	Cap Screw, 1/2-13 X 1 Hex "	
17	119-5	A/R	Washer, Flat 1/2 "	
18	118-5	A/R	Washer, Lock 1/2 "	
19	116-5	A/R	Nut, 1/2 "	
20	854748-A	2	Clamp/3 Hole. Top Half	
21	854748	2	Clamp, Hose 3 Hole Complete Set	
22	854748-B	2	Clamp/3 Hole. Bottom Half	
	750241A	A/R	Flashing, 25X6.0 X 34. Main (Not Shown)	

Head Pulley Assembly

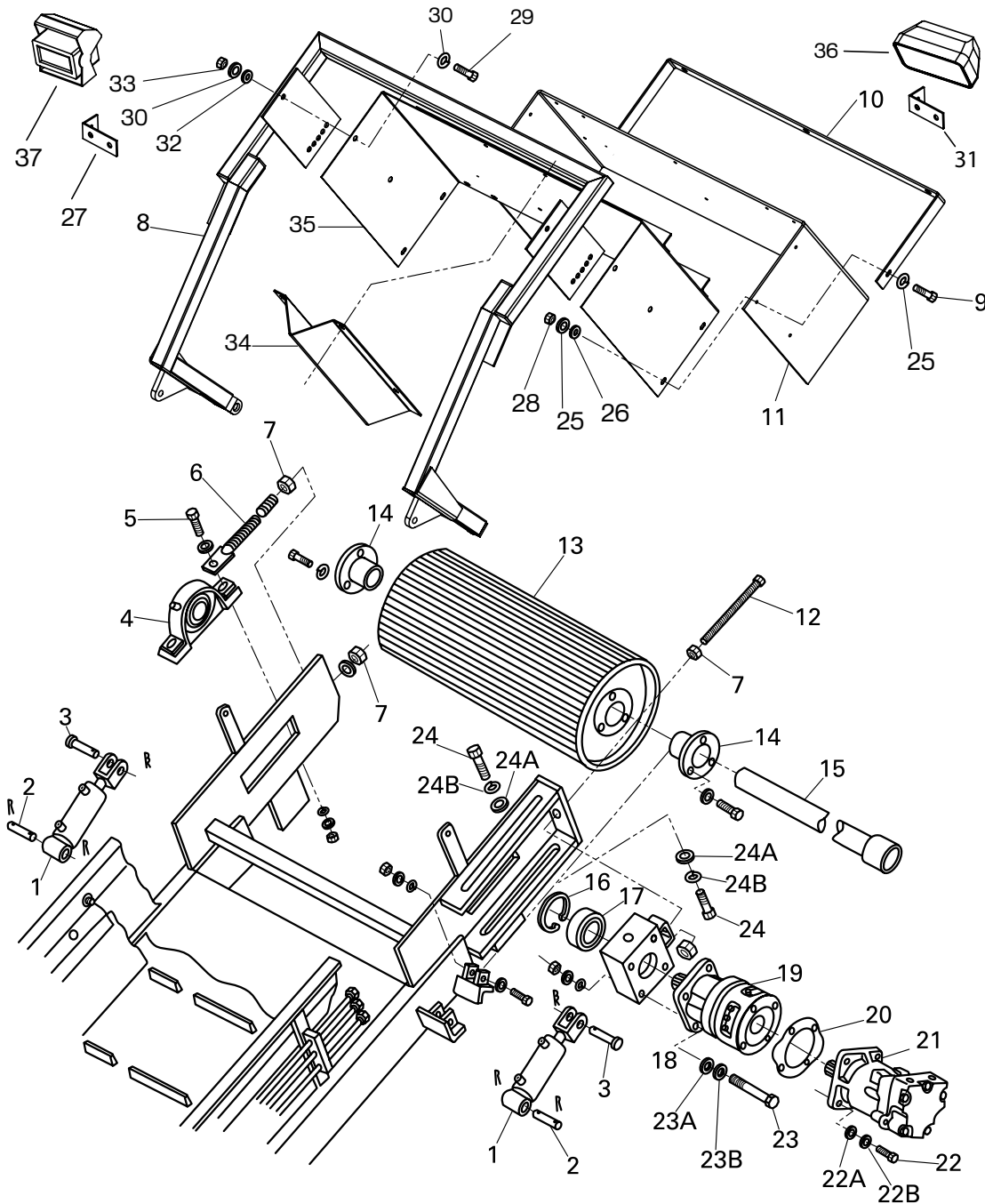

Figure 10-10

Head Pulley Assembly Parts List

Item No.	Part Number	Qty.	Description	Remarks
1	P521124	2	Hyd.Cyl.,Discharge Baffle	
	38922-01	A/R	Seal Kit	
2	856997	2	Bar, Round W/2 Holes	
3	210060	2	Pin, Clevis	
4	710160-28R	1	Bearing, Conveyor Head Pulley R.H. (2800)	
5	102-716-1A	2	CSHH, 3/4-10 X 3-3/4"	
6	750321	2	Adj. Bolt, Main Conveyor Belt R.H.	
7	116-8	4	Nut, 3/4-10 Hex "	
8	1004581	1	W/m, Deflector Mount	
9	P521452	12	Elevator Bolt, 1/4-20 X 1" "	
10	1004584	1	Bar, Deflector Brace	
11	1003919	1	Shield, Loader Bucket	
12	854744	1	Adj. Rod, Tail Pulley	
13	750260	1	Pulley, Head Drum W/Lag	
14	750051	2	Bushing, 2800 / 3000 Conveyor Head Pulley	
15	750271	1	Shaft, 2800 / 3000 Conveyor Head Pulley	
16	750323	1	Snap Ring, Conveyor L.H. Bearing Retainer	
17	520100	1	Bearing, 400 Stub Axle (3) "	
18	854788	1	Motor Mount	
19	750300	1	Torque Hub, 2800 / 3000 Conveyor Drive	
20	P77494	1	Gasket, S.A.E. C" 4 Hole "	
21	750310	1	Hyd. Motor, Main Conveyor Drive	
22	102-411-1A	4	Cap Screw, 1/2-13 X 2-1/2" Hex Head "	
22A	119-5	4	Washer, 1/2 S.A.E. Flat "	
22B	118-5	4	Washer, 1/2 Lock "	
23	102-609-1A	4	Cap Screw, 5/8-11 X 2" Hex Head "	
23A	119-7	4	Washer, 5/8 S.A.E. Flat "	
23B	118-7	4	Washer, 5/8 Lock "	
24	102-909-1A	2	Cap Screw, 1-8 X 2" Hex Head "	
24A	119-10	2	Washer, 1 S.A.E. Flat "	
24B	118-10	2	Washer, 1 Lock "	
25	118-4	2	Washer,Lock,,437	
26	119-4	1	Flat Washer, 7/16" SAE	
27	1004383	1	Camera Mount Brkt	
28	116-4	1	Nut,Hex,,437-14	
29	102-607-1A	2	CSHH,.625-11X1.50,GR5 Cap Screw	
30	118-6	2	Washer,Lock,,563	
31	1004383	1	Light, Mount Brkt	

Head Pulley Assembly (continued)

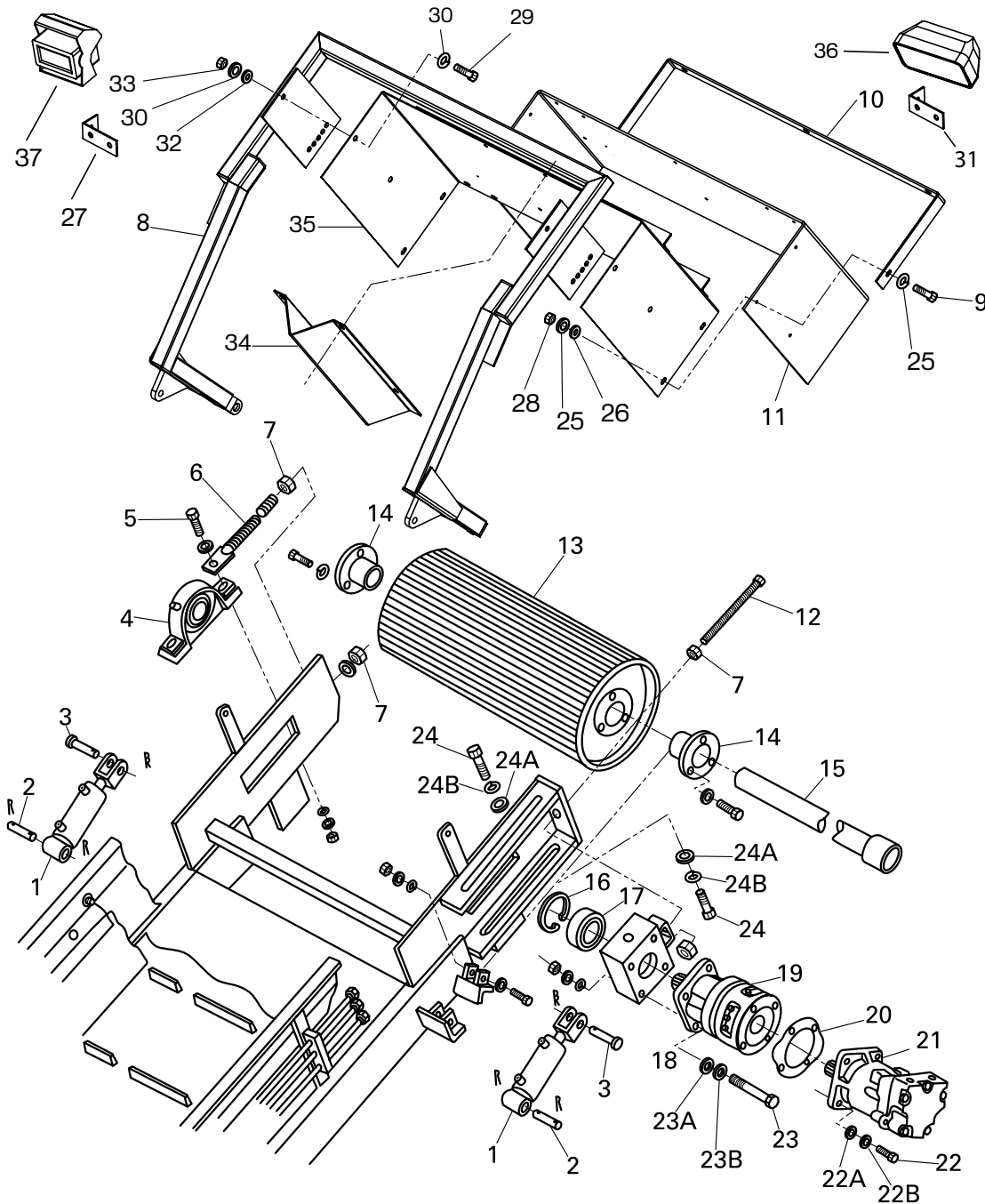

Figure 10-10

Head Pulley Assembly Parts List (continued)

Item No.	Part Number	Qty.	Description	Remarks
32	119-7	1	Washer,FLAT,SAE,.625	
33	116-7	1	Nut,Hex,.625-11	
34	1004577	1	Defuser	
35	1004580	1	W/m, Defuser	
36	160040A	1	Light,Halogen,Trap,55 Watt	
37	1003907	1	Camara,Color,Outdoor,12VDC	
38	1004383	1	Camera Mount Brkt	

Cab Assembly

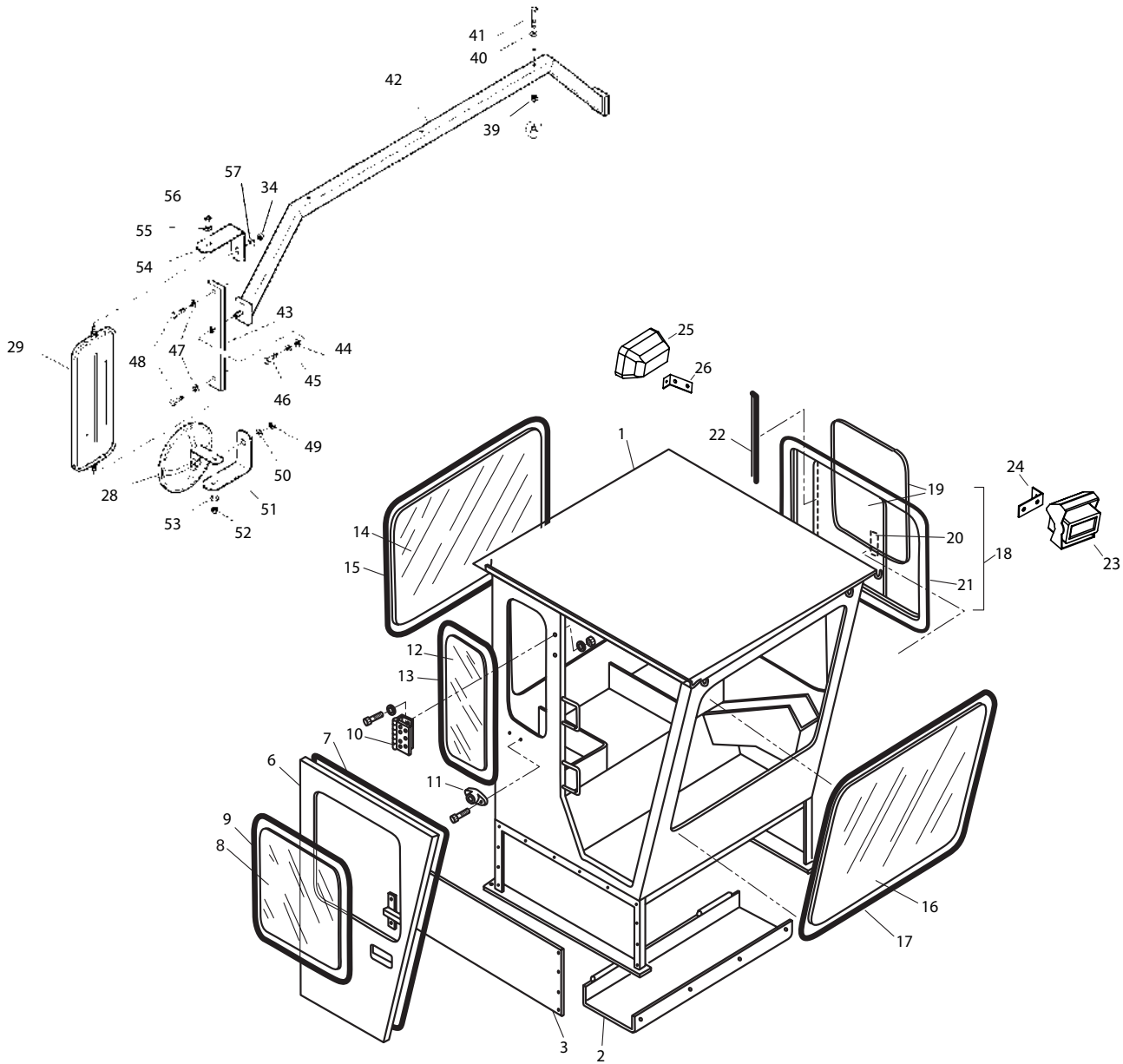

Figure 10-11

Cab Assembly Parts List

Item No.	Part Number	Qty.	Description	Remarks
1	760010A		Cab Weldment	
2	760021		Cover Hoses	
3	760031		Panel Side	
6	760062		Door	
7	760070		Seal Door	
8	760080		Window Door	
9	760090		Seal Window	
10	760101		Hinge,3000,Loader,Cab	
11	P527323		Socket, Door, Stop	
12	760120		Window Right Side	
13	760090		Seal	
14	760130		Window	
15	760090		Seal Rear	
16	760140		Window Front	
17	760090		Seal Front	
18	760150		Window Assembly	
19	760160		Window Right	
20	760090		Seal Side	
• 21	760170		Frame Window	
22	760180		Seal Window	
23	1003907	1	Cable, Camera System, 4PIN,49	
24	1004383	1	Camera Mount Brkt	
25	160040A	1	Light, Halogen, Trap, 55 Watt	
26	1004383	1	Light Mounting Brkt	
28	151370	2	Mirror, Outside Rearview	
29	852570	2	Mirror Head, West Coast	
30	856987	2	Mount, Light, Mirror	Not Shown
31	1003862	2	Light, 5', Tractor	Not Shown
32	1003863	2	Cover, Red	Not Shown
33	211748-02	2	Strobe Light, Amber	Not Shown
34	116-3	1	Nut, 3/8"-16 Hex	
35	853700	1	Kit, A/C/Heat, 3000	Not Shown
36	100944	1	Belt	Not Shown
37	P52281	1	Hose, Defroster	Not Shown
38	TF10199	1	Hose, Heater, 625	Not Shown
39	143-3	3	Locknut, 3/8"-16	
40	119-3	3	Flat Washer, 3/8" SAE	
41	102-211-1A	3	Cap Screw, 3/8"-16 x 2.50 Hex	

Cab Assembly (continued)

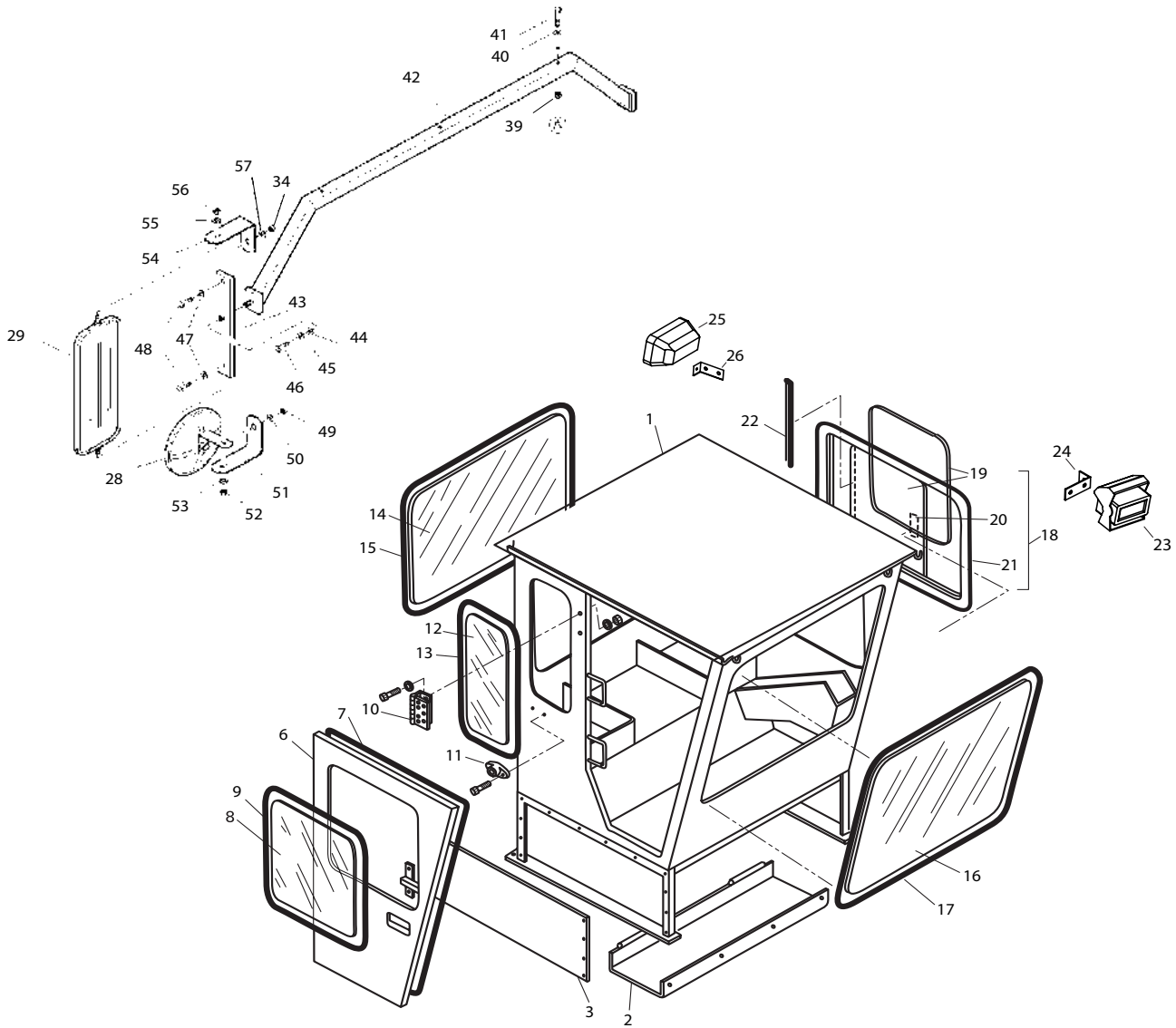

Figure 10-11

Cab Assembly (continued) Parts List

Item No.	Part Number	Qty.	Description	Remarks
42	985624	1	Mounting Bar, Mirror	
43	856896	2	Mounting Bar, Mirror Group	
44	119-5	1	Flat Washer, 1/2" SAE	
45	118-5	1	Lockwasher, 1/2"	
46	102-406-1A	1	Cap Screw, 1/2"-13 X 1.25 Hex	
47	119-3	1	Flat Washer, 3/8" SAE	
48	102-208-1A	1	Cap Screw, 5/16"-18 X 1.75 Hex	
49	116-3	1	Nut, 3/8"-16 Hex	
50	118-3	1	Lock Washer, 3/8"	
51	856987	4	Mounting Bracket, Mirror	
52	143-3	4	Locknut, 3/8"-16 Hex	
53	119-3	4	Flat Washer, 3/8" SAE	
54	856987	4	Mounting Bracket, Mirror	
55	119-3	4	Flat Washer, 3/8" SAE	
56	143-3	4	Locknut, 3/8"-16 Hex	
57	118-3	1	Lock Washer, 3/8"	

Cab Door

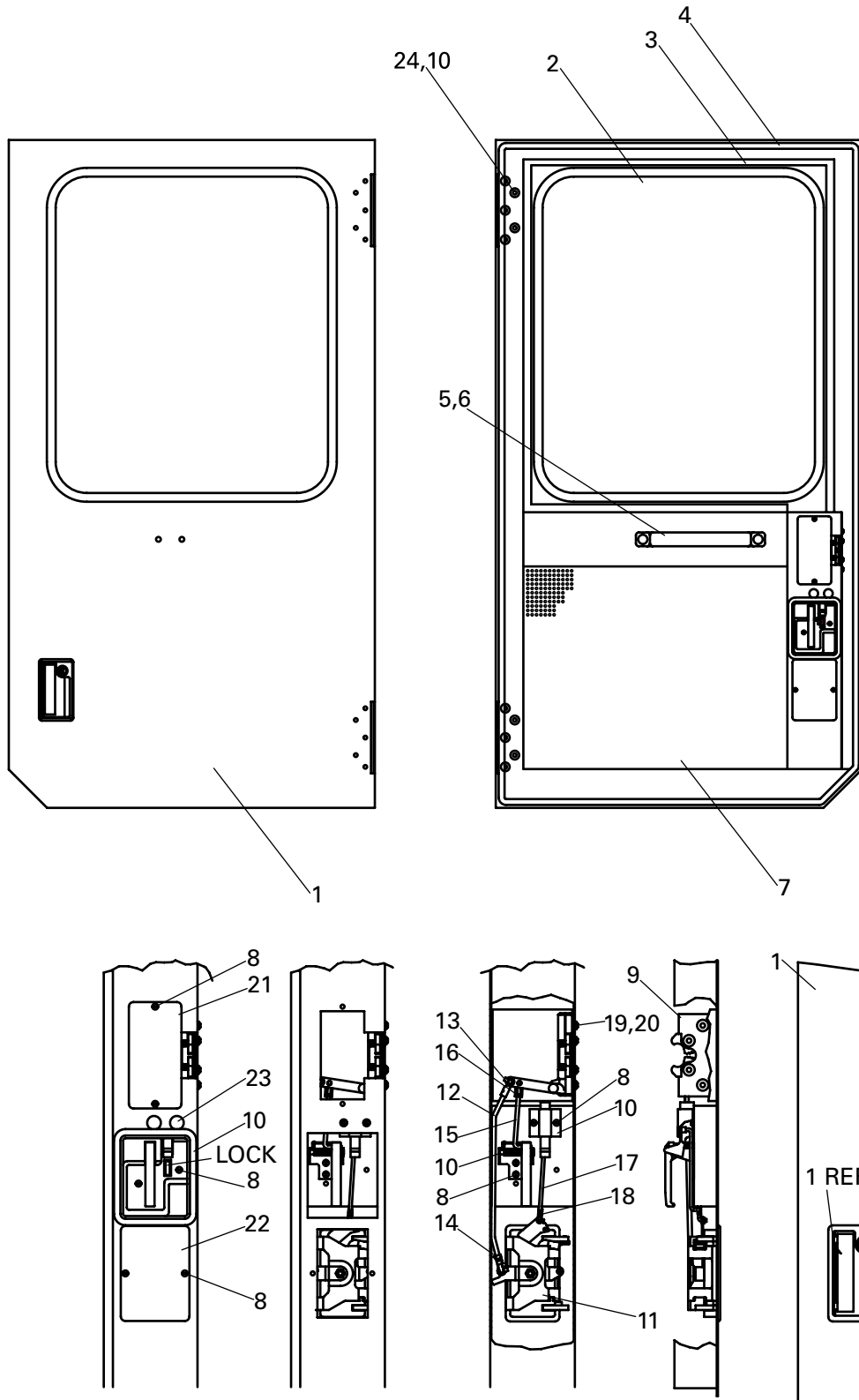

Figure 10-12

Cab Door Parts List

Item No.	Part Number	Qty.	Description	Remarks
1	760062	1	Door Weldment	
2	760080	1	Glass - Door	
3	760090	9FT.	Windshield Seal	
4	760070	15 FT	Edge Trim	
5	982060	1	Interior Handle	
6	A510-B	2	1/4 -20 Phphil X 5/8 "	
7	982061	1	Foam - Door	
8		10	8-32 Phms X 1/2	
9	982062	1	Latch - Smc Modified - Rh	
10	982063	1	Int. Handle & Bezel- Rh	
11	982064	1	O.S. Paddle Handle - Rh	
12	982065	1	Latch Rod, Lh	
13	982066	1	7/32 Rod Clip - Rh	
14	982067	1	7/32 Rod Clip - Lh	
15	982068	1	Rh I/S Trip Rod	
16	982069	1	3/16 Rod Clip - Plstc - Cntr	
17	982070	1	Lock Trip Rod - 5/32 Dia. - Cntr	
18	982071	1	5/32 Rod Clip - Rh	
19		4	1/4-20 Bhscs X 5/8	
20		4	1/4 Int Tooth Lk Wshr	
21	982072	1	Cover	
22	982073	1	Cover	
23	982075	2	3/8 Dia. Hole Plug - Plstc	
24	982076	10	Plug, 3/4, Button, Nylon, Black	
25	760010A-02	1	Key, Door	Not Shown

Cab Components

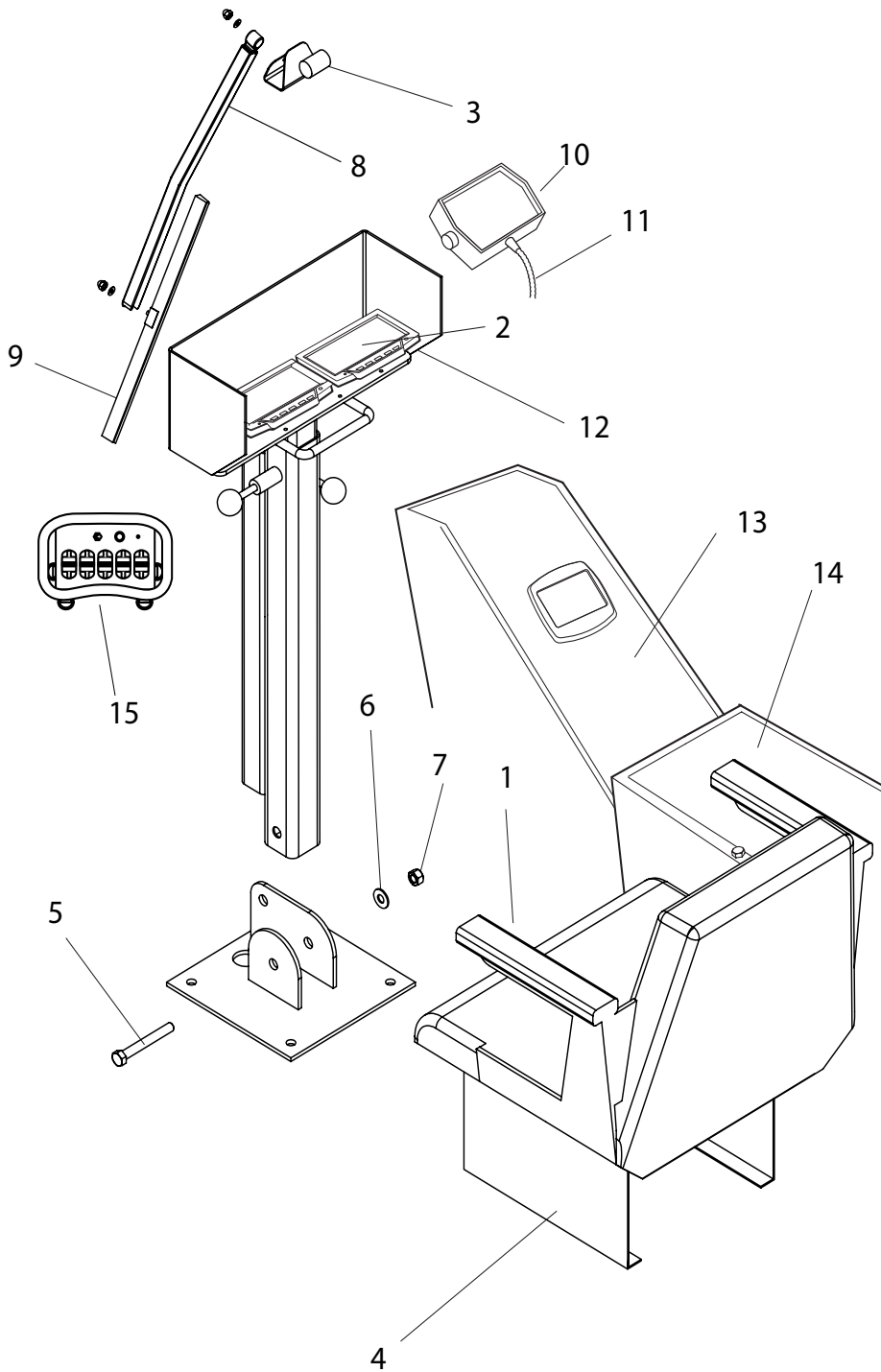

Figure 10-13

Cab Components Parts List

Item No.	Part Number	Qty.	Description	Remarks
1	360010B	1	Seat Assy,Black,W/Armrest	
2	1004668	2	Assy,Monitor Mount 3000SS	
3	151170	3	Motor,Windshield Wiper	
4	140600	4	Suspension Bracketry,Seat, Low	
5	102-615-1A	5	CSHH,.625-11X3.50,GR5 Cap Screw, 5/8-11 X 3-1/2 Hex	
6	119-7	6	Washer,Flat,SAE,.625 Flat Washer, 5/8" SAE	
7	116-7-1	7	Nut,Hex,Jam,.625-11 nut, 5/8"-11 Hex Jam	
8	151180	8	Arm,Windshield Wiper	
9	151190	9	Blade,Windshield Wiper,20"	
10	983414-02	10	Topcon V Control	
11	1004565	11	Harness, Topcon, Curly Cord, Sand Shark	
12	1004668	12	Assy,Monitor Mount 3000SS	
13	REF ONLY	13	Switch and Indicator	
14	REF ONLY	14	Auger/Feeder Control Panel	
15	1004229	15	Sifter,Remote Control, Transmitter/Receiver	
16	1002085	N/S	Conn,21-Pin,Plug,HD Series	

Conveyor Controls

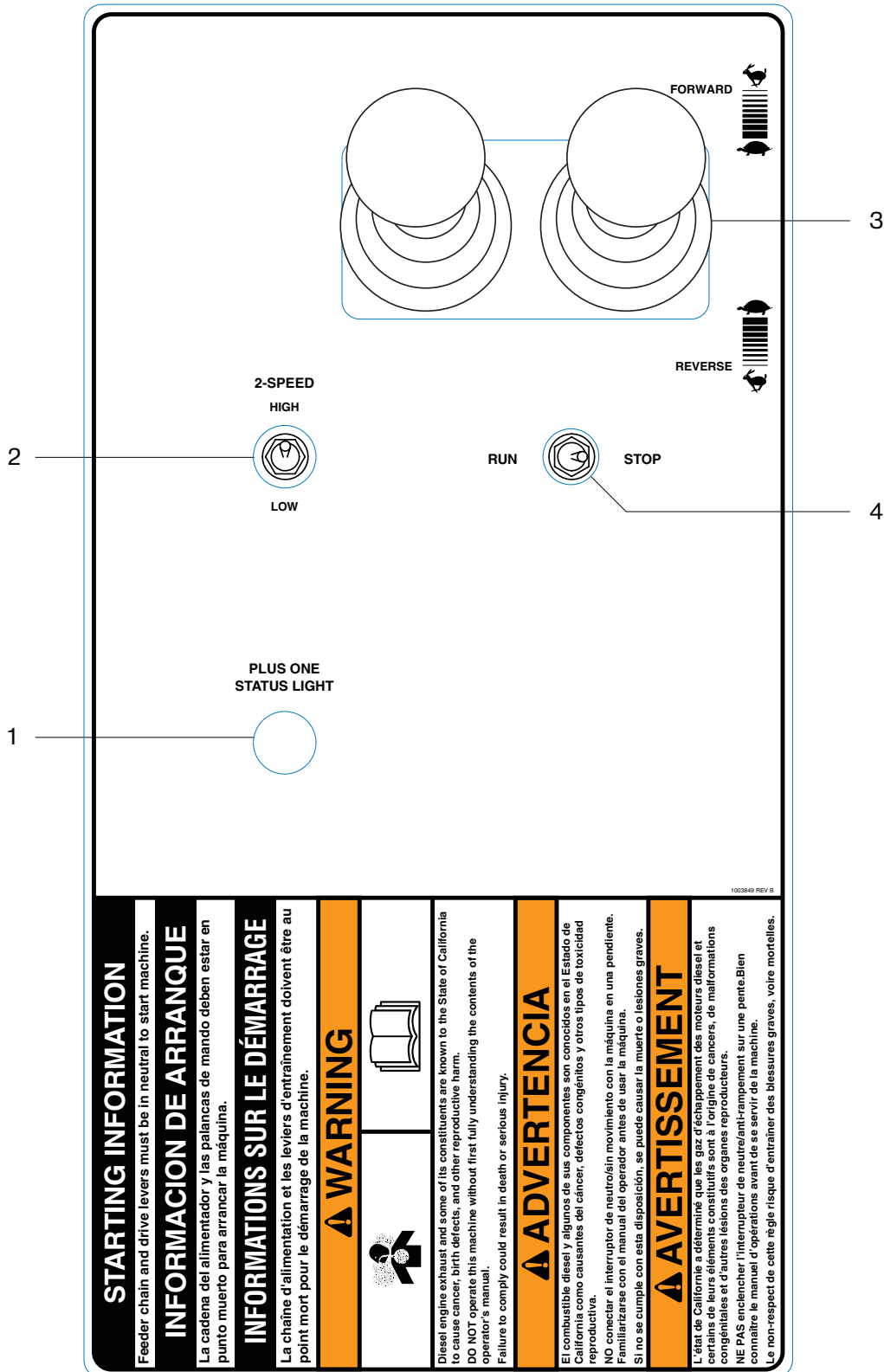

Figure 10-14

Conveyor Controls Parts List

Item No.	Part Number	Qty.	Description	Remarks
1	1001625	1	Light,Amber, Dash, 50 Hole	
2	851090624	1	Switch, Toggle Spot,2POS Toggle Sw. (3Pole)	
3	987134-02	2	Joystick	
4	851090624	1	Switch, Toggle Spot,2POS Toggle Sw. (3Pole)	

Switch and Indicator Panel

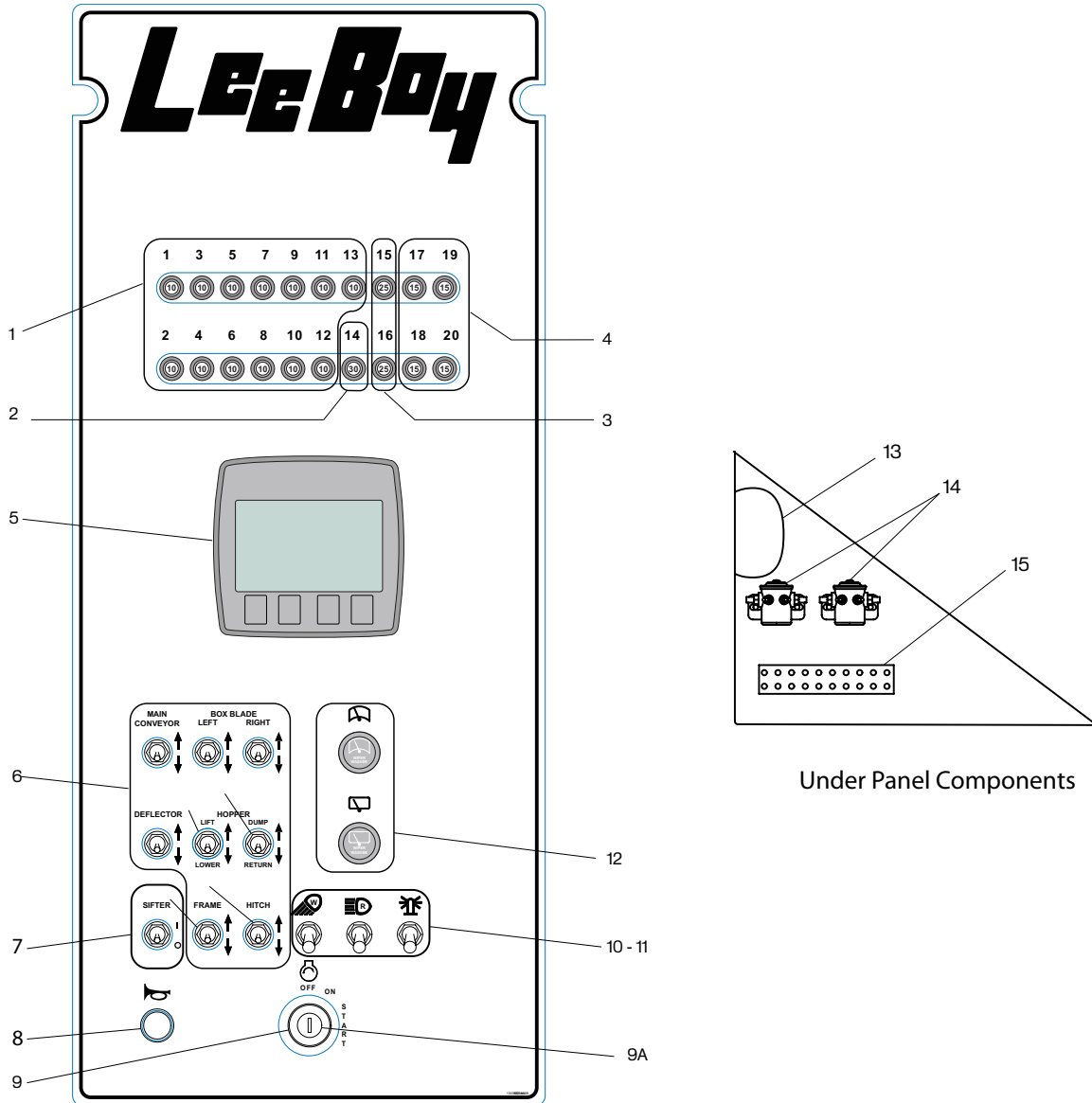

Figure 10-15

Switch and Indicator Panel Parts List

Item No.	Part Number	Qty.	Description	Remarks
1	34964	13	Circuit Breaker, 10A, Pan MT / Circuit Breaker	
2	989261	1	Circuit Breaker, 30A, Pan MT	
3	35701	2	Circuit Breaker,25A PanMT / Circuit Breaker	
4	989260	4	Circuit Breaker, 15A Pan MT	
5	988699	1	Display, Graphic, B&W DP200 / DP-200	
6	851392	8	Switch, Toggle, 3-Pos, Spdt, Mom	
7	851090624	1	Switch, Toggle, 2-Pos, Spdt, Toggle Switch (3 POS)	
8	982249	1	Switch, Push Button	
9	39146-14	1	Switch, Ignition w/ Heat ST / Kubota	
9A	982008-04	1	Key. Ignition,Kubota, 300B,635/Order 1 Receive 2Keys	
10	851391	3	Switch, Toggle, SPST,2-Pos, 2 Speed High/Low	
11	851441	3	Weather Boot, toggle Switch/ (Long)	
12	853090	2	Switch, Wipper/ Washer (3000)	
13	151200	1	Tank,Windshield Wiper Washer	
14	720290	2	Solenoid,12V,Constant Duty/ 635B/685 Instrument Panel	
15	987982	1	Terminal Block, 10 Gang	

Right Side Control Panel

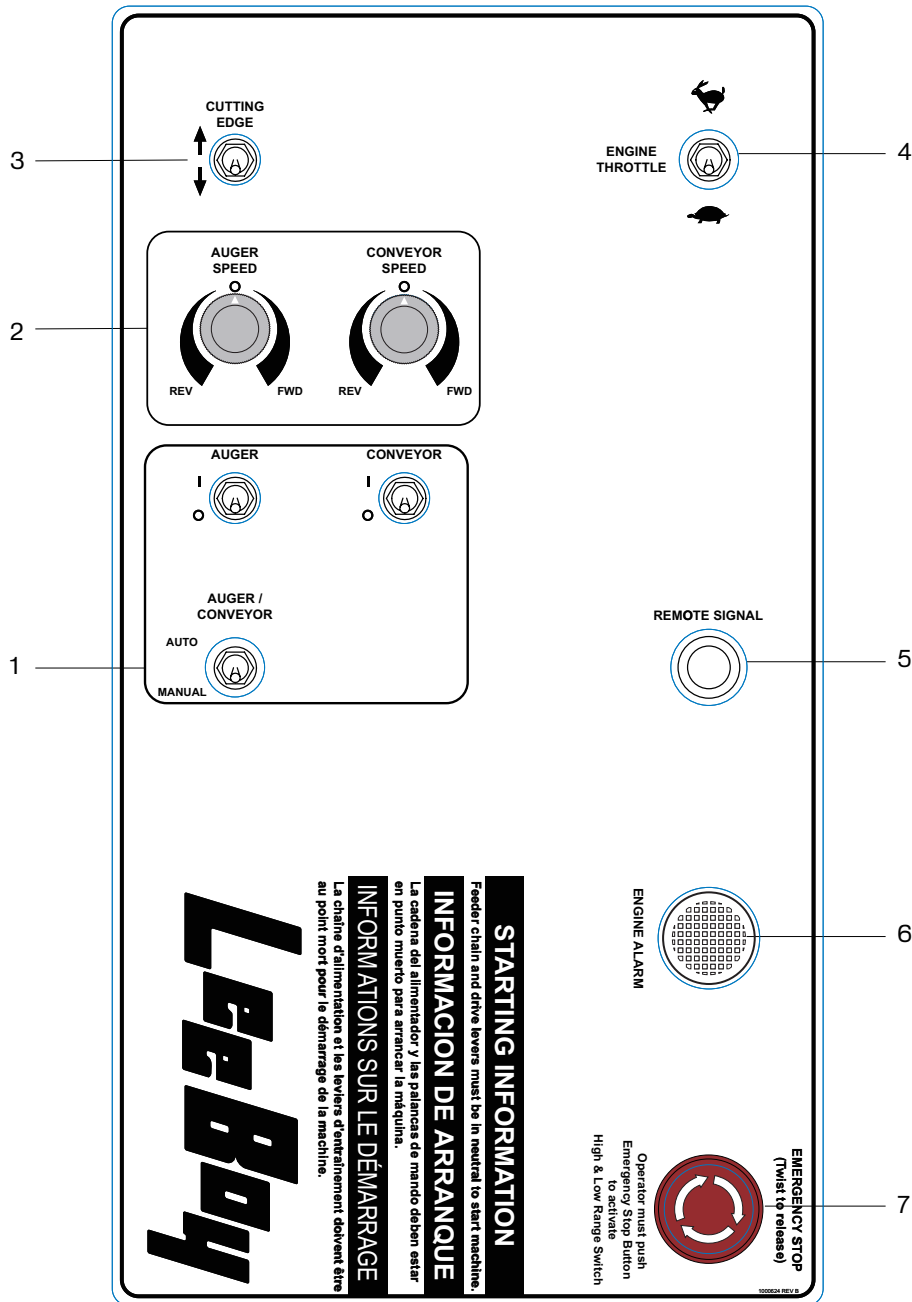

Figure 10-16

Right Side Control Panel Parts List

Item No.	Part Number	Qty.	Description	Remarks
1	851090624	3	Switch, Toggle, SPDT, 2 -POS / Toggle Sw (3P1oe)	
2	35050	2	Potentiometer, 100 Ohm / Potentionmeter	
3	851392	1	Switch, Toggle, Spdt, 3-Pos, Mom	
4	851392	4	Switch, Toggle, 3-Pos, Spdt, Mom	
5	36150	1	Remote , Signal	
6	36208	1	Buzzer, 12 V DC, Continuous Tone / Buzzer Continuous Tone 12 V DC	
7	988924-10	1	Switch, E-Stop, Base W/ Button	
8	1003456	1	Plus-One Controller (Controls, 50 Pin) Generic	
9	1003851	1	Harness, Plus 1,Sand Shark	

Tier III Engine and Pumps

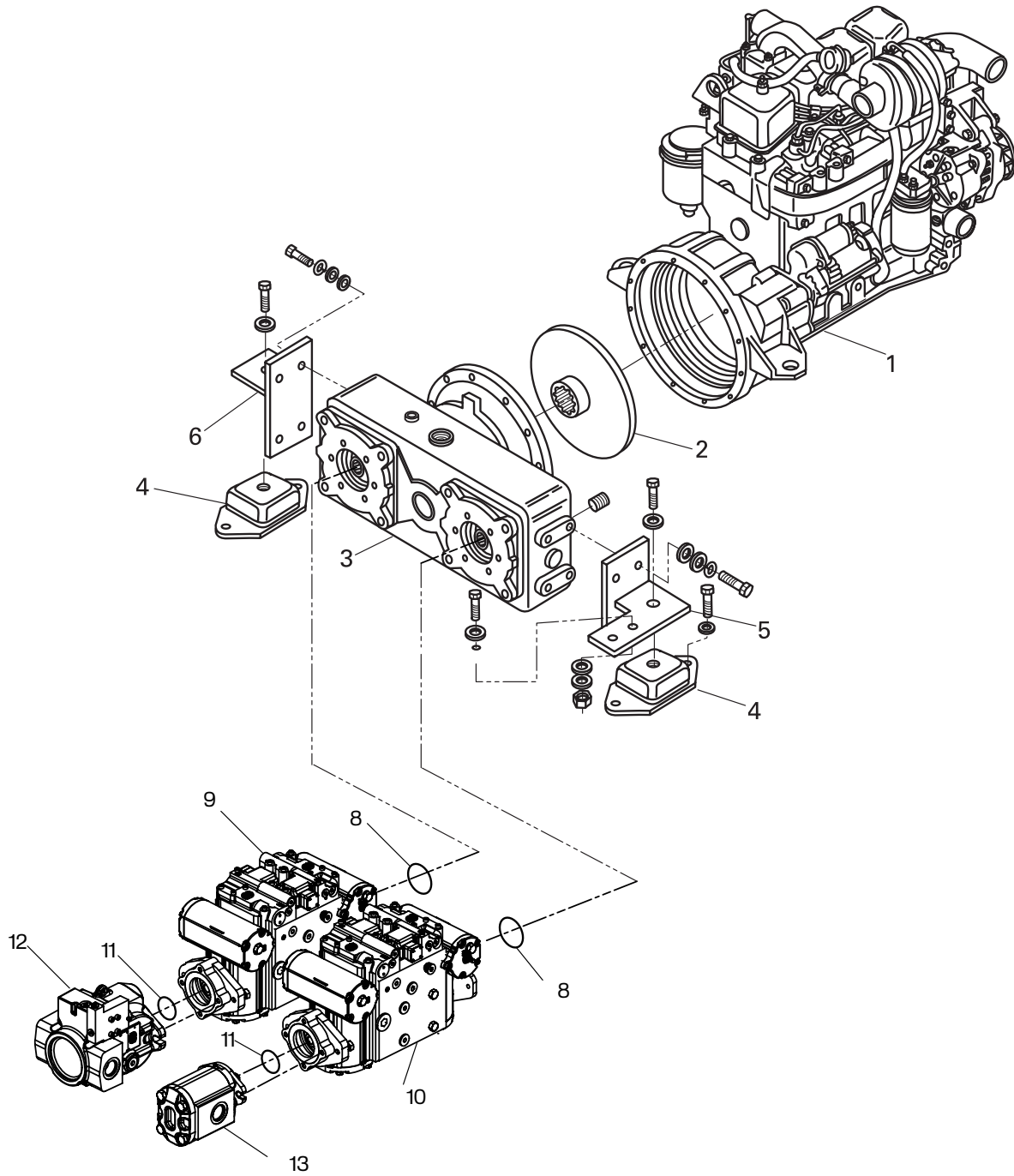

Figure 10-17

Tier III Engine and Pumps Parts List

Item No.	Part Number	Qty.	Description	Remarks
1	1003900	1	Engine, Cummins, 152HP, T3	
2	P86879B	1	Coupling, Flywheel Pump Drive	
3	P76869A	1	Pump Drive,Dual,3000	
4	320140	2	Mounting Pad	
5	981778	1	Motor Mount,LH	
6	750581	2	Motor Mount,RH	
7	851545	1	EDC Controller	Not Shown
8	984992	2	O-Ring, Tandem/Gearbox	
9	980400	1	Pump Drive,Hyd,Double Drive	
10	980470	1	Pump,Variable	
11	980493	2	O-Ring	
12	980490	1	Pump,Hyd,Load Sense,38CC	
13	980500	1	Pump,Gear Charge	
-	34464		Element,Hyd,Chg Filter	Not Shown

Tier III Engine Components

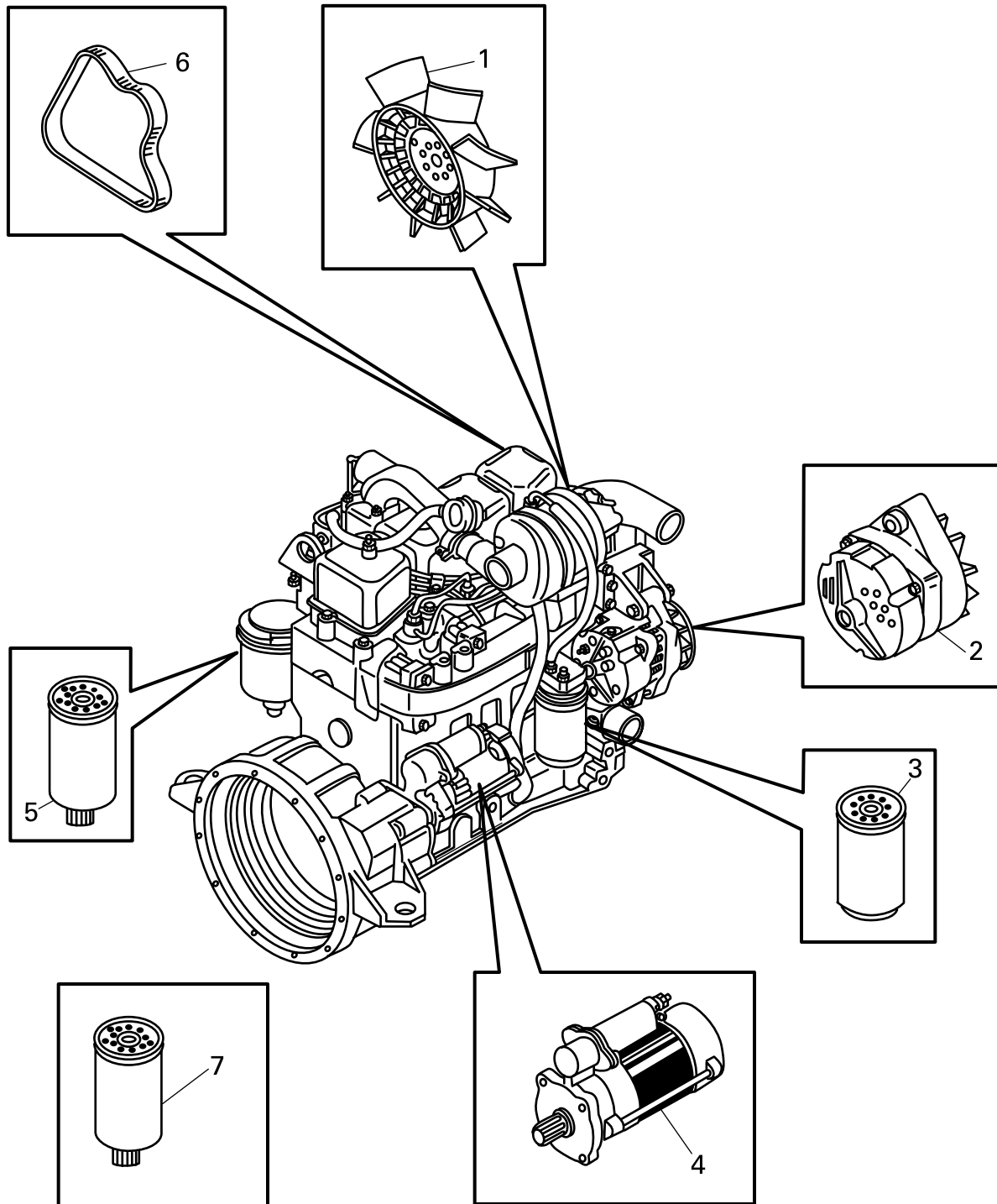

Figure 10-18

Tier III Engine Components Parts List

Item No.	Part Number	Qty.	Description	Remarks
1	988934	1	Fan, Multi Wing. 22" Dia	
2	1003861	1	Alternator. 160 Amp	
3	988666-03	1	Element, Oil Filter, 4.5 Qsb	
4	988666-02	1	Starter, Denso. R2.7	
5	988666-04	1	Element, Fuel Filter, 4.5 Qsb	
6	988666-07	1	Belt, Alternator, Cummins 4.5L	
7	988666-05	1	Filter Element, Fuel/Water Separator	

Hood and Engine Access Panels

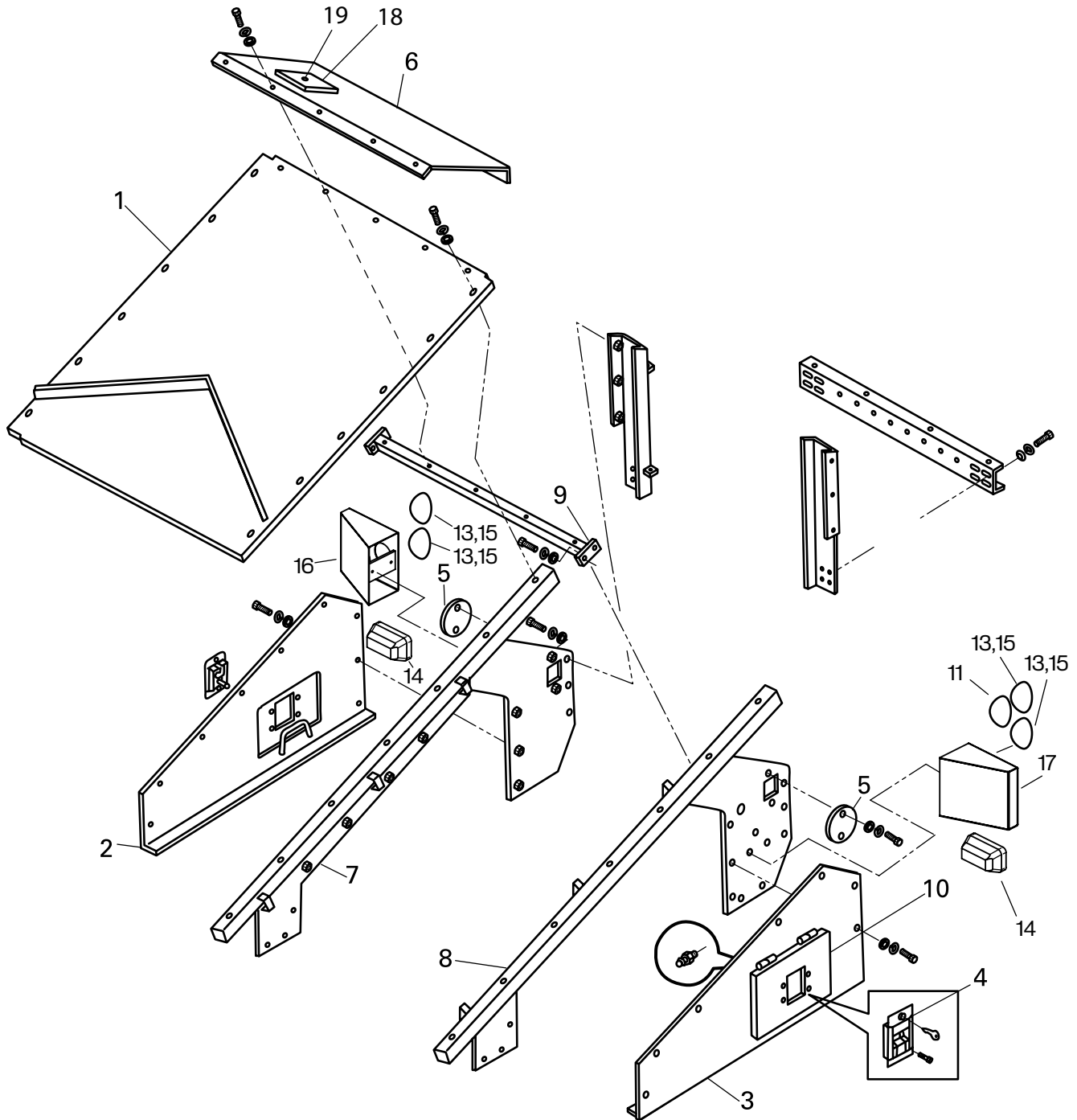

Figure 10-19

Hood and Engine Access Panels Parts List

Item No.	Part Number	Qty.	Description	Remarks
1	1000072	1	W/M. Engine Cover Loader	
2	988812	1	W/M. Engine Side Cover Rh	
3	988813	1	W/M. Engine Side Cover Lh	
4	160450	2	Latch, Engine Access Panel	
4A	35560		Key, Vandalism Lock	
5	855132	1	Cover	
6	988753	1	Group, Engine Hood Loader	
7	1000556	1	Plate, Frame Side Right 3000	
8	1000557	1	Plate, Frame Side Left 3000	
9	171231	2	Shaft, Main Conveyor Support	
10	986742	2	W/M. Engine Door Rh	
11	852520	1	Back Up Alarm (3000)	
12	853600	2	Gas Shock, Engine Back Door	Not Shown
13	160030A	1	Light, Tail, Red	
14	160040A	2	Light, Halogen, Trap, 55 Watt	
15	160030A1	4	Grommet, Tail Lamp Mounting	
16	981564	1	Tail Light Box, RH	
17	981565	1	Tail Light Box, LH	
18	988753	1	Grp, Engine Hood, Loader	
19	160460	1	Latch, Radiator Access Panel	Not Shown
20	35560	A/R	Key, Vandalism Lock	
21	1000623		Decal Kit	

Muffler Assembly

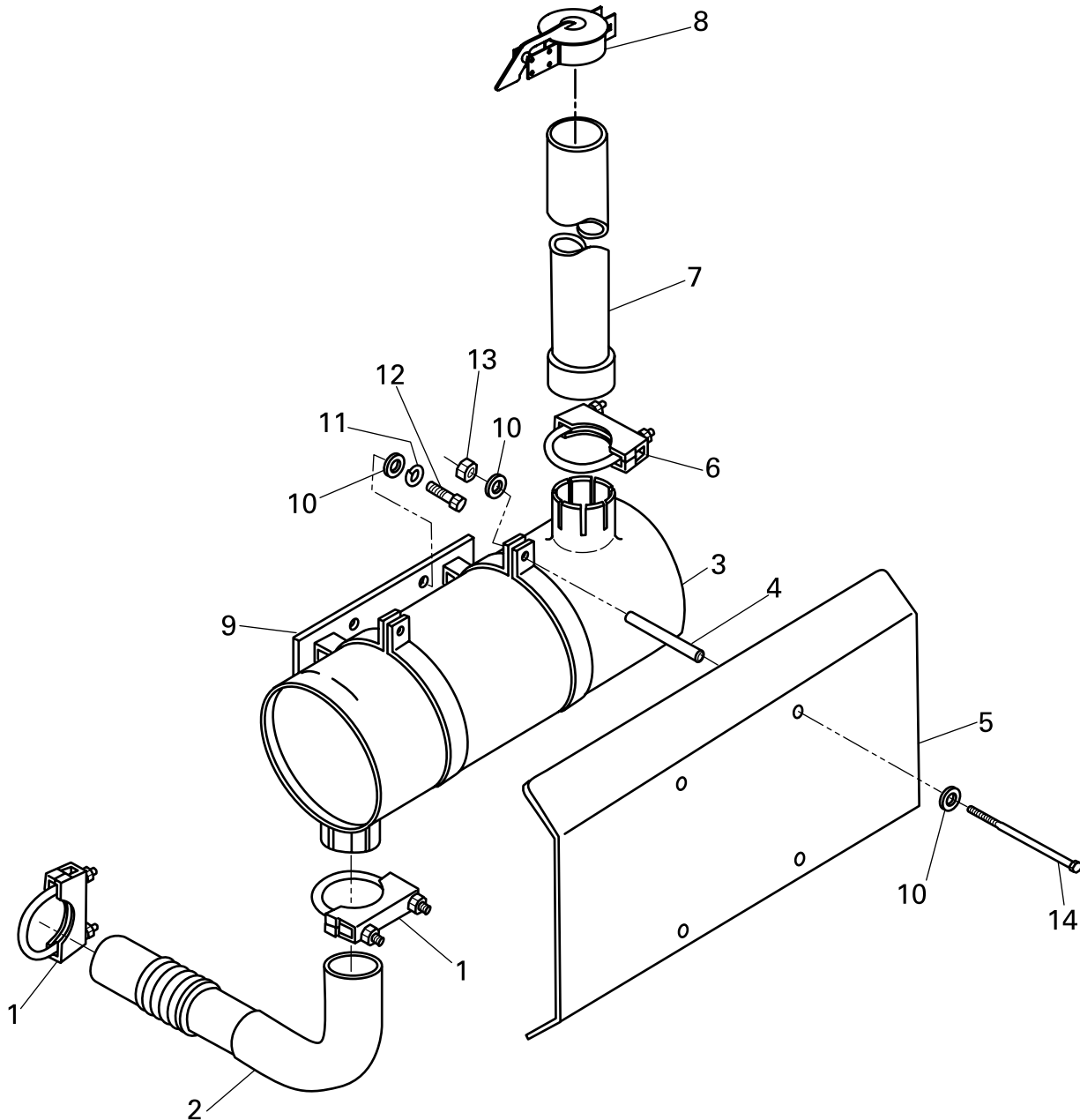

Figure 10-20

Muffler Assembly Parts List

Item No.	Part Number	Qty.	Description	Remarks
1	161250	2	Clamp, 3 Muffler "	
2	750042	1	Elbow W / Flex Pipe, 3000 Exhaust	
3	750043	1	Muffler, 3000 Exhaust	
4	856999	4	Spacer Tube, 3000 Exhaust Heat Shield	
5	750045	1	Plate, 3000 Muffler Heat Shield	
6	750046	1	Clamp, 3-1/4 Muffler "	
7	750047	1	Pipe, 3000 Exhaust Stack	
*8	750041	1	Rain Cap, 3" Exhaust Pipe	
9	750048	1	Plate W / Clamps, 3000 Muffler Mount	
10	119-3	3	Washer, 3/8 Sae Flat "	
11	118-3	2	Washer, 3/8 Lock "	
12	102-205-1A	4	Cap Screw, 3/8-16 X 1 Hex "	
13	116-3	4	Nut, 3/8-16 Hex "	
14	102-225-1A	4	Cap Screw, 3/8-16 X 6" Hex Head "	

Air Cleaner Assembly

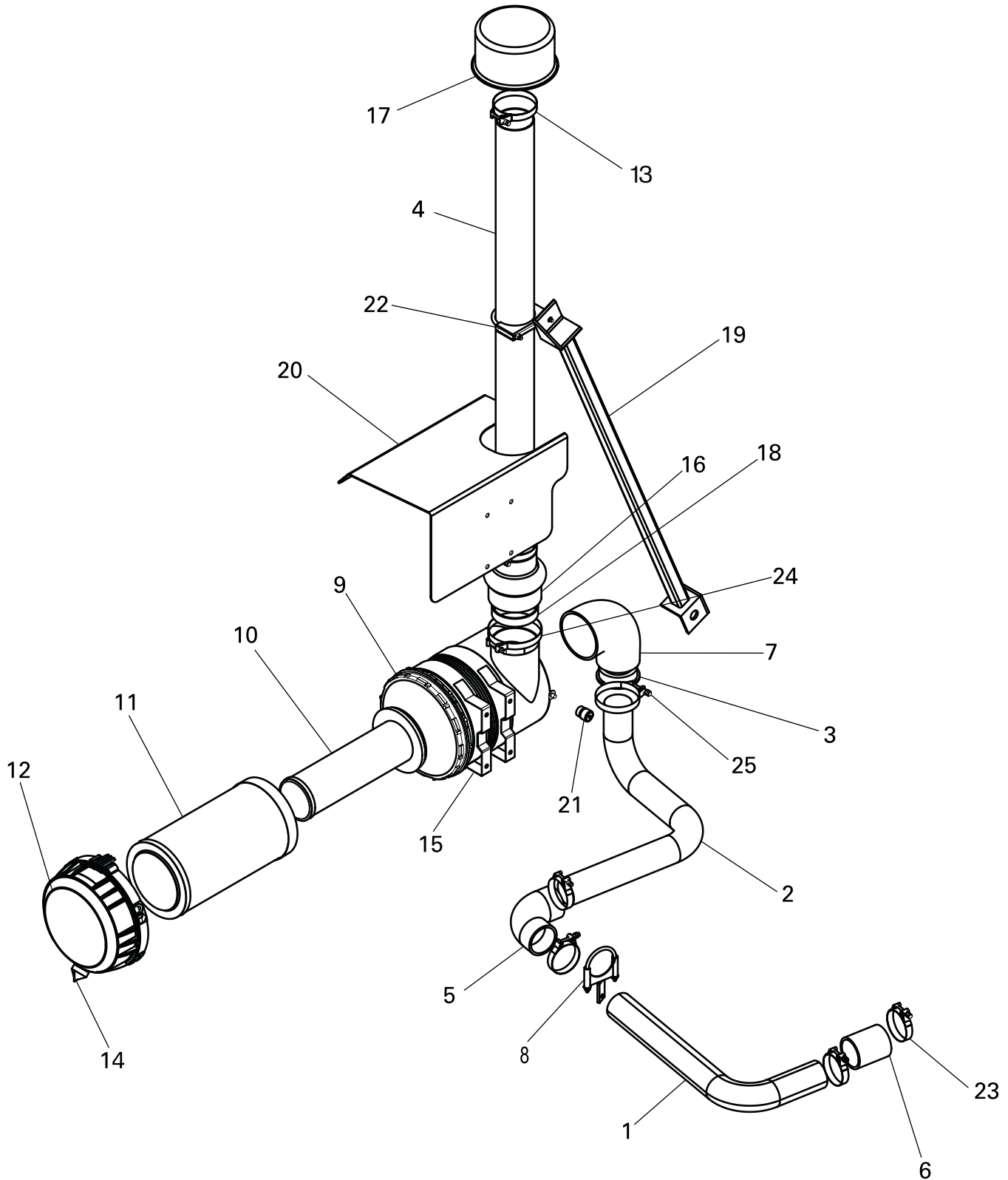

Figure 10-21

Air Cleaner Assembly Parts List

Item No.	Part Number	Qty.	Description	Remarks
1	1000500	1	Tube, Bent Air Intake, 3.00 Od	
2	1000501	1	Tube, Bent Air Intake, 3.00 Od	
3	1000575	1	Reducer, Rubber, 3.00 Id/4.00 Od	
4	1000723	1	Pipe, Air Intake, 4.00X54.00	
5	34031	1	Elbow, Rubber, 90, 3.00 Id	
6	987281	1	Tube, High Temp, 3" Id X 4"L, Str	
7	72172	1	Elbow, Rubber, 90, 5.00X 4.00 Id	
8	855151	1	Air Cleaner Mount	
9	988962	1	Air Cleaner	
10	988962-02	1	Element, Secondary	
11	988962-01	1	Element, Primary	
12	988962-04	1	Cover	
13	953521243	3	Clamp, T-Bolt, 4.00 Id	
14	988962-03	1	Dust Ejection Valve	
15	989242	2	Band, Mounting	
16	953521244	1	Hump Hose, Reducer, 5.00-4.00 Id	
17	852060	1	Filter, Air Pre-Cleaner	
18	1000862	1	Tube, Sleeve, Loader Air Cleaner	
19	1000721	1	W/M, Air Intake Stabilizer, 3000	
20	1000707	1	Pl, Cover, Air Cleaner, 3000	
21	171220	1	Indicator, Air Filter	
22	34040	1	Clamp, Muffler, 4.00 Id	
23	171090	4	Clamp, T-Bolt, 3.00 Id	
24	72174	2	Clamp, T-Bolt, 5.00 Id	

Grille and Radiator Assembly

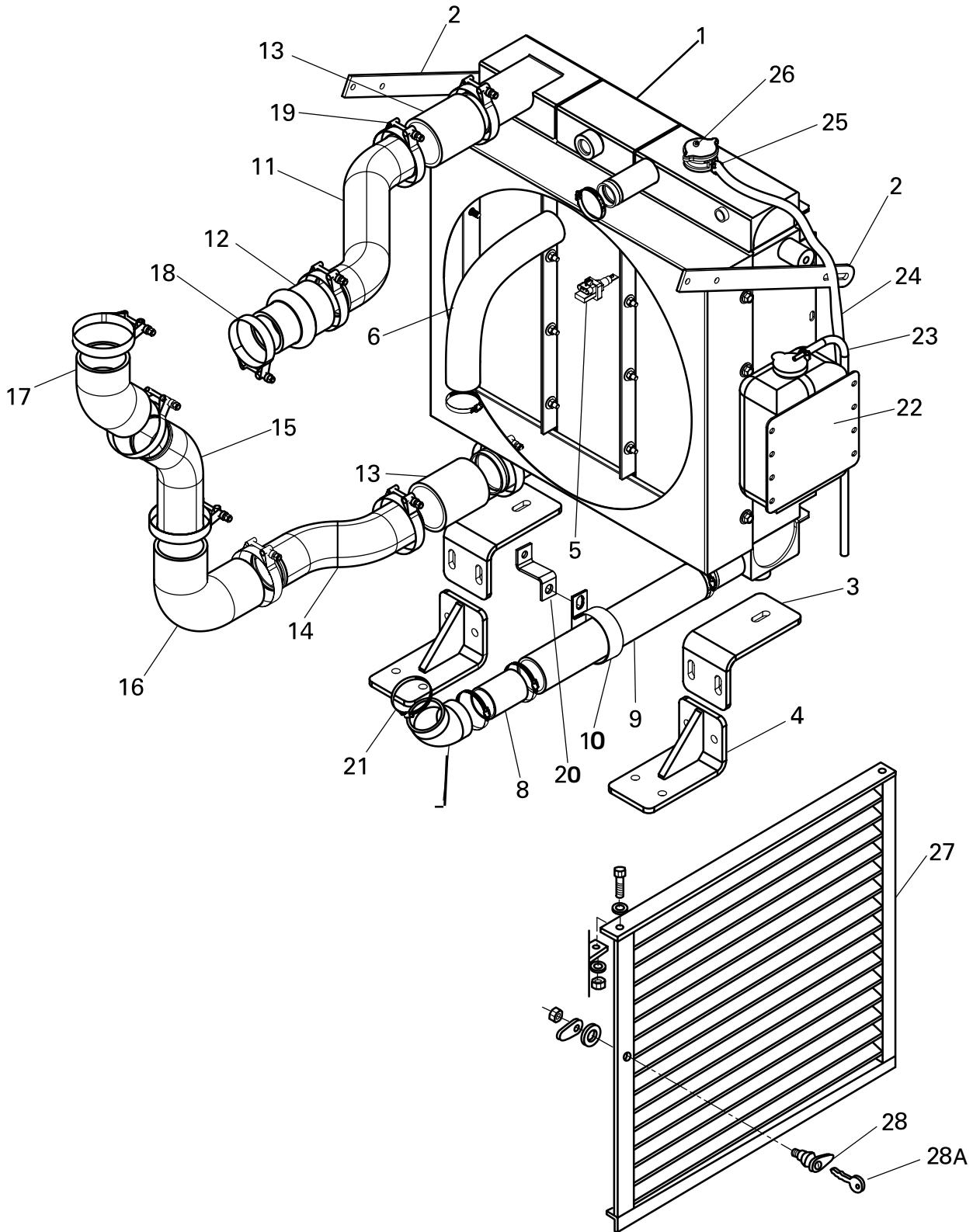

Figure 10-22

Grille and Radiator Assembly Parts List

Item No.	Part Number	Qty.	Description	Remarks
1	988646	1	Rad/Cac/Oil Cooler	
2	988748	2	Link, Top Rad Gusset	
3	988759	2	W/M, Frt Rad Mount	
4	988762	2	W/M, Rear Rad Mount	
5	988986	1	Sensor, Coolant Level	
6	170100A	1	Hose, Radiator, Lower	
7	984262	1	Elbow, Rubber, 60, 2.25 Id	
8	42541	1	Tube, Rnd, 2.25Od X 2.00Id X3.00 Lg	
9	170071A	1	Hose, Radiator, Upper 685B/3000	
10	148-232	1	Clamp, Insulated Band, 2 1/2"	
11	1000504	1	Tube, Bent, Charge Air, 3.00 Od	
12	982780	1	Reducer	
13	987281	2	Tube, High Temp, 3"Id X 4"L, Str	
14	1000502	1	Tube, Bent, Charge Air, 3.00 Od	
15	1000503	1	Tube, Bent, Charge Air, 3.00 Od	
16	987282	1	90 Degree Elbows	
17	982779	1	90 Degree Elbows	
18	171090	1	Clamp, T-Bolt, 3.00 Id	
19	171190	9	Clamp, T-Bolt, 3.50 Nominal	
20	1004599	1	Plate,Bent,Radiator Hose Bracket	
21	500230	4	Number 36, Hose Clamp	
22	983273	1	Tank, Radiator Overflow	
23	32882-01	1	Hose, 04, Push-On, 3.0 Ft Lg	
24	71812-01	1	Hose, 05. Push-On, 3.0 Ft Lg	
25	33277	3	Number 4, Hose Clamp	
26	988646-01	1	Cap, Radiator	
27	750554SRV	1	Grill	
28	160460	1	Latch, Radiator Access Panel	
28A	35560	A/R	Key Vandalism	
29	1004599	1	Plate,Bent,Radiator Hose Bracket	

Hitch Assembly

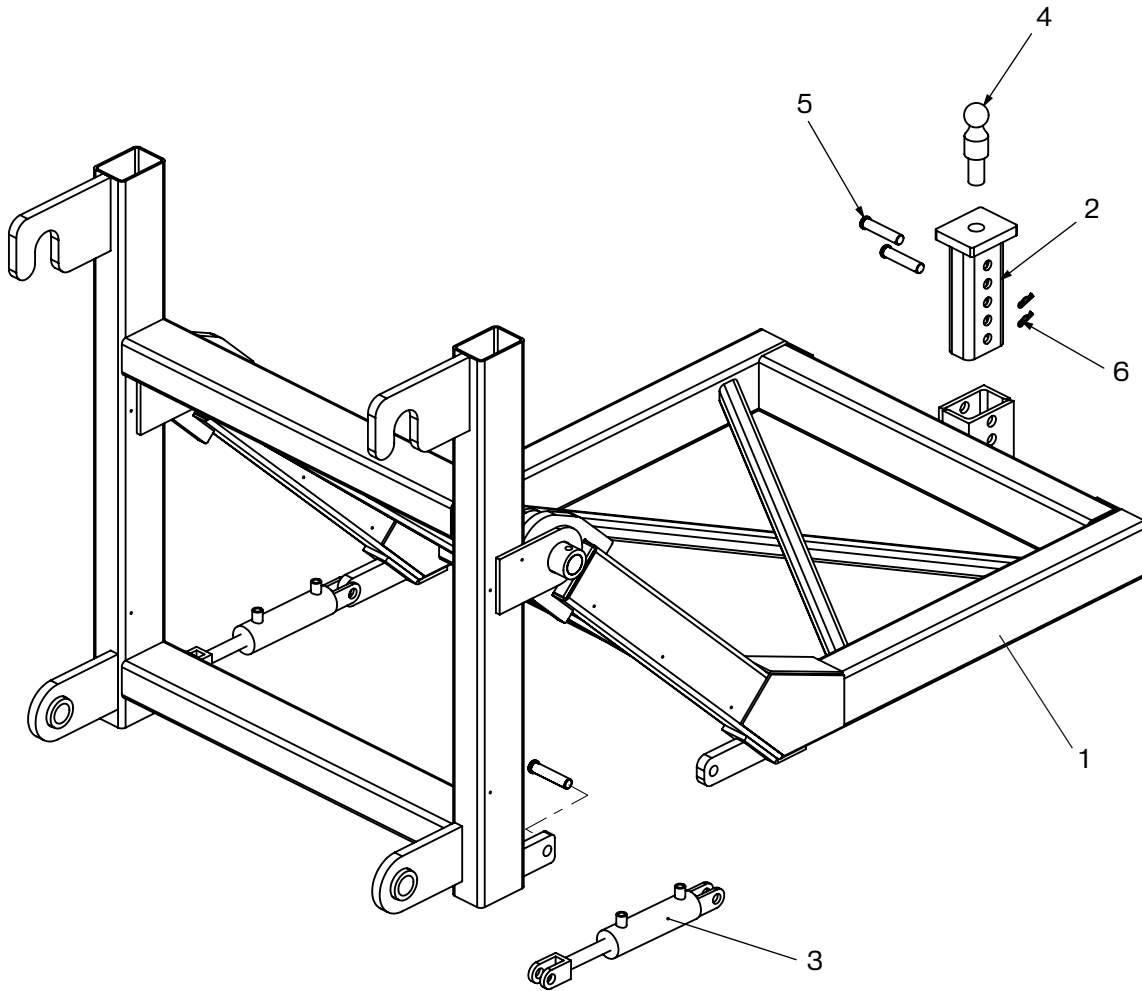

Figure 10-23

Hitch Assembly Parts List

Item No.	Part Number	Qty.	Description	Remarks
1	1004233	1	Loader, Rear Connection	
2	1004794SRV	1	W/M Hitch Drawbar	
3	37293	2	Cylinder, Hydraulic	
-	37620-05	A/R	Seal Kit	Not Shown
4	1004234	1	Ball Hitch, 2-5/16	
5	980167SRV	1	Pin, 1" OD x 5.25"	
6	870307	2	Cotter Pin	

Sifter Assembly

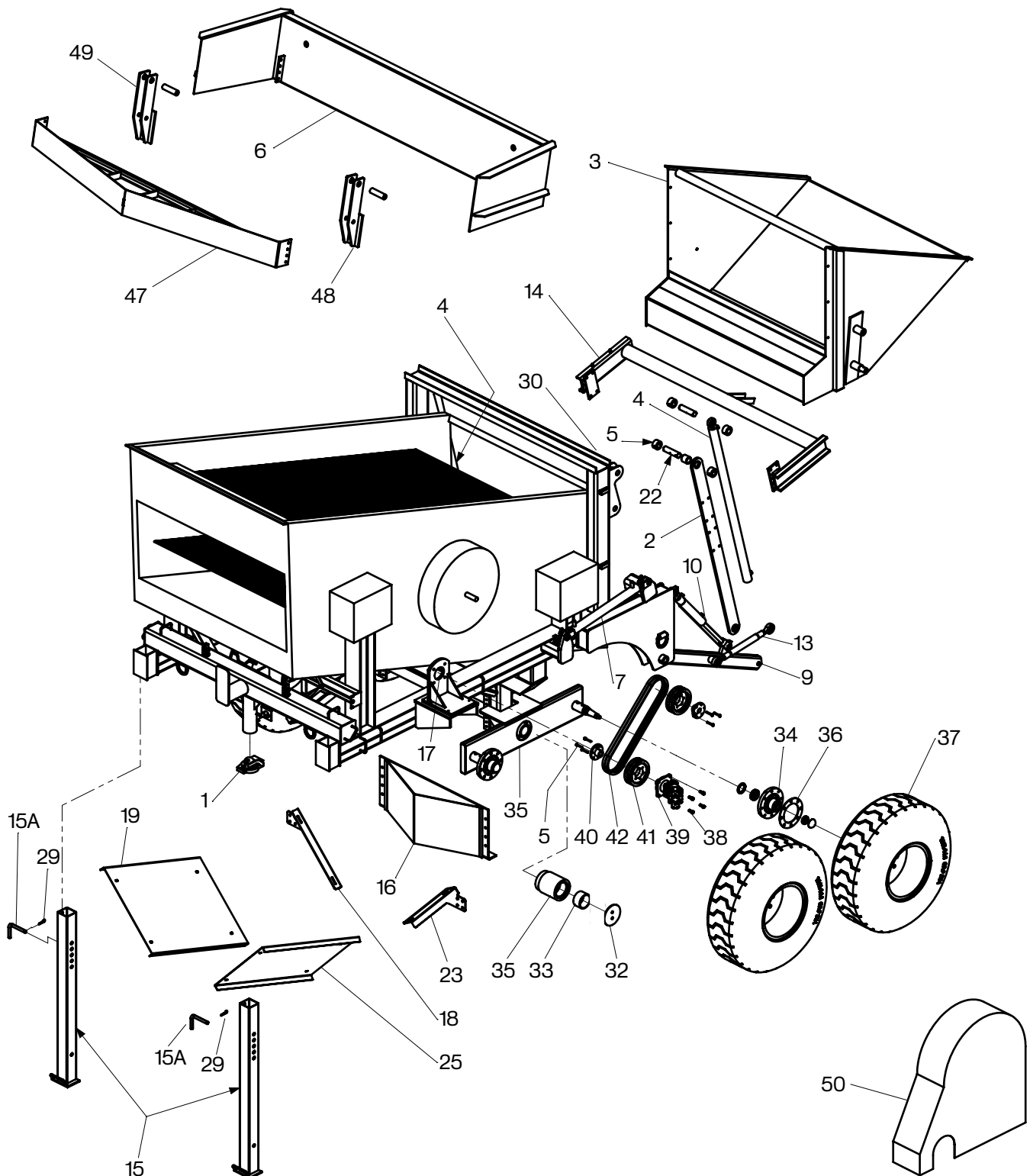

Figure 10-24

Sifter Assembly Parts List

Item No.	Part Number	Qty.	Description	Remarks
1	1004191556	1	Latch, Goose Neck, 2 -5/16"	
2	1004118	2	Weldment,Dump Arm	
3	1004196556	1	Weldment,Bucket	
4	1004241556	2	Cyl,Hyd Bucket Dump	
5	80214	7	Hfbolt 0.3125-18X2.25x0.875-N	
6	1004167	1	Ass'y,Strike Off	
7	640220	2	Cyl,Hyd 2.50X12.00,2500psi	
8	1004422	4	Tube, Spindle Pin Stop	
9	1004155556	1	Arm,Strike Arm Lh	
10	260060	2	Cyl,Hyd,2,0Bx6.0s,W/Sensor	
11	80387	4	Hx-Shcs 0.5-20X1.125x1.125-N	Not Shown
12	1004154556	1	Arm,Strikeoff Rh	
13	P526113	2	Turnbuckle	
14	1004122556	1	Brace,Dump Arms	
15	1004182556	2	Ass'y,Leg Shaker	
15A	28747	2	Pin, Cotter	
16	1004178556	1	Ass'y,Drag Plate	
17	1004254556	1	Weldment,Motor Mount	
18	1004407556	1	Bracket,Deflector Rh	
19	1004403556	1	Deflector Rh	
20	1004405	1	Bracket,Deflector Rh	Not Shown (Welded)
21	1004416	2	Pin,Bucket Lift	
22	1004417	4	Pin,Bucket Lift	
23	1004406556	1	Bracket,Deflector Lh	
24	1004404	1	Bracket,Deflector Lh	Not Shown (Welded)
25	1004402556	1	Deflector Lh	
26	80248	2	Bolt, Hex Hvy 1/2"-13 X 1"	
27	1004442556	2	Bar,Bucket Safety Prop	
28	1004423	8	Pin,Clevis 1.00 X 3.25 W 3 Holes	
29	7303	2	Hairpin Cotter Pin	
30	1004535	2	Bracket,Camera Plug	
31	1004536556	1	Brace,Bucket Arm	
32	1001681556	2	Cover, Bogie Shaft	
33	989699	4	Bushing Fiber	
34	36136	4	Hub, Wheel Complete #W45-8	
35	1004151556	2	Weldment,Tandum Axle	
36	1004387	4	Spacer,Wheel 3000SS	
37	100391655W	4	Tire And Rim	

Sifter Assembly (continued)

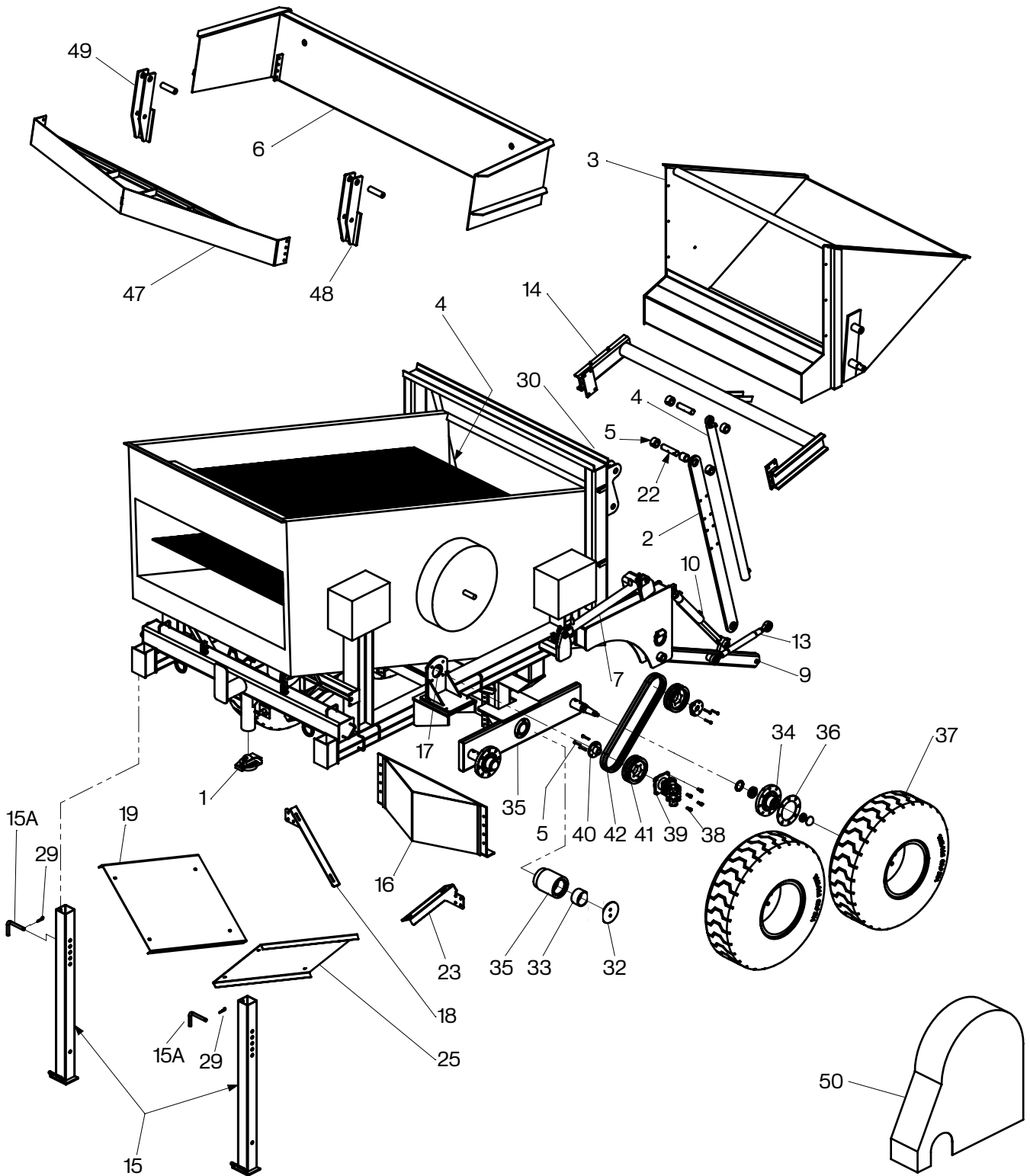

Figure 10-24

Sifter Assembly (continued) Parts List

Item No.	Part Number	Qty.	Description	Remarks
38	80387	4	Hx-Shcs 0.5-20X1.125x1.125-N	
39	1004102	4	Motor	
	1004102-01	A/R	Seal Kit	Not Shown
40	1004250	2	Bushing, Taperlock	
41	1004847	2	Pulley, Sifter Drive	
42	1004391	2	Belt, V-Grooved C-67	

ALPHABETICAL PARTS INDEX

Description	Part Number	Figure Number	Item Number
1/2" Female Hydraulic Quick Disconnect	1004612	15C	10-7
1/2" Female Hydraulic Quick Disconnect Cap	1004614	15D	10-7
1/2" Male Hydraulic Quick Disconnect	1004611	15A	10-7
1/2" Male Hydraulic Quick Disconnect Cap	1004613	15B	10-7
1/4 -20 Phphil X 5/8 "	A510-B	6	10-12
1/4 Int Tooth Lk Wshr		20	10-12
1/4-20 Bhscs X 5/8		19	10-12
3/16 Rod Clip - Plstc - Cntr	982069	16	10-12
3/8 Dia. Hole Plug - Plstc	982075	23	10-12
3/8" Female Hydraulic Quick Disconnect	1004608	14C	10-7
3/8" Female Hydraulic Quick Disconnect Cap	1004610	14D	10-7
3/8" Male Hydraulic Quick Disconnect	1004607	14A	10-7
3/8" Male Hydraulic Quick Disconnect Cap	1004609	14B	10-7
5/32 Rod Clip - Rh	982071	18	10-12
7/32 Rod Clip - Lh	982067	14	10-12
7/32 Rod Clip - Rh	982066	13	10-12
8-32 Phms X 1/2		8	10-12
90 Degree Elbows	987282	16	10-22
90 Degree Elbows	982779	17	10-22
Adj. Bolt, Main Conveyor Belt R.H.	750321	6	10-10
Adj. Rod, Tail Pulley	854744	12	10-10
Air Cleaner	988962	9	10-21
Air Cleaner Mount	855151	8	10-21
Alternative 1-Bar TGA	CR6096/46/500	—	10-3
Alternative 1-Bar TGA	CR6096/46/500	—	10-4
Alternator. 160 Amp	1003861	2	10-18
Arm,Strike Arm Lh	1004155556	9	10-24
Arm,Strikeoff Rh	1004154556	12	10-24
Arm,Windshield Wiper	151180	8	10-13
Assy, Axle Pivot Guide Wheel	1004373	7	10-1
Assy, Padde Shaft --- L.H.	750551SRV	16	10-2
Assy, Temp Bail W/Sleeves	983414-10	28	10-1
Assy, Under Carriage Bracing	1003828	13	10-6
Ass'y,Drag Plate	1004178556	16	10-24
Ass'y,Leg Shaker	1004182556	15	10-24
Assy,Monitor Mount 3000SS	1004668	2	10-13
Assy,Monitor Mount 3000SS	1004668	12	10-13
Ass'y,Strike Off	1004167	6	10-24

Description	Part Number	Figure Number	Item Number
Assy. Paddle Beaing, Adj. L.H.	750550	15	10-2
Assy. Paddle Beaing, Adj. R.H.	750552	18	10-2
Assy. Paddle Shaft, Adj. R.H.	750553SRV	17	10-2
Auger (Snow) L/H - P/S Only	W522855	28	10-2
Auger (Snow) R/H - P/S Only	W522854	29	10-2
Auger/Feeder Control Panel	REF ONLY	14	10-13
Back Up Alarm (3000)	852520	11	10-19
Ball Hitch, 2-5/16	1004234	4	10-23
Ball Joint,,250,Female	920080	20	10-1
Band, Mounting	989242	15	10-21
Bar, Deflector Brace	1004584	10	10-10
Bar, Round W/2 Holes	856997	2	10-10
Bar,Bucket Safety Prop	1004442556	27	10-24
Bearing Insert 3.00 / 400 Stub Axle / 3000	520100	30	10-2
Bearing, 2800 / 3000 Conveyor Tail Pulley	750040	3	10-8
Bearing, 400 Stub Axle (3) "	520100	17	10-10
Bearing, Conveyor Head Pulley R.H. (2800)	710160-28R	13	10-2
Bearing, Conveyor Head Pulley R.H. (2800)	710160-28R	4	10-10
Belt	100944	36	10-11
Belt, Alternator, Cummins 4.5L	988666-07	6	10-18
Belt, V-Grooved C-67	1004391	42	10-24
Blade Paddle, 2800 / 3000 Feeder	710240556	6	10-2
Blade,Windshield Wiper,20"	151190	9	10-13
Bolt	1004426-08	10	10-3
Bolt	1004426-09	11	10-3
Bolt	1004426-13	15	10-3
Bolt	1004426-14	16	10-3
Bolt	1004426-15	17	10-3
Bolt	1004426-08	10	10-4
Bolt	1004426-09	11	10-4
Bolt	1004426-13	15	10-4
Bolt	1004426-14	16	10-4
Bolt	1004426-15	17	10-4
Bolt 1" x 8	984138	31	10-2
Bolt, Conveyor Adjusting	W520862	9	10-8
Bolt, Hex Hvy 1/2" -13 X 1"	80248	26	10-24
Brace,Bucket Arm	1004536556	31	10-24
Brace,Dump Arms	1004122556	14	10-24
Bracket Z Arm TOPCON	9090-1125SRV	14	10-1
Bracket, Tail Pulley Bearing Adjustment	750052	4	10-8

Illustrated Parts List (IPL)



Description	Part Number	Figure Number	Item Number
Bracket,Camera Plug	1004535	30	10-24
Bracket,Deflector Lh	1004406556	23	10-24
Bracket,Deflector Lh	1004404	24	10-24
Bracket,Deflector Rh	1004407556	18	10-24
Bracket,Deflector Rh	1004405	20	10-24
Bracket,Sonic Tracker,Topcon	851578	13	10-1
Bracket,Sonic Tracker,TOPCON	851575SRV	16	10-1
Burn Out Guard, 3000 Tail Pulley	750061	8	10-8
Bushing Fiber	989699	33	10-24
Bushing, 2800 / 3000 Conveyor Head Pulley	750051	14	10-10
Bushing, 2800 / 3000 Conveyor Tail Pulley	750050	5	10-8
Bushing, Lower Feeder Shaft (Bronze)	710183	21	10-2
Bushing, Taperlock	1004250	40	10-24
Buzzer, 12 V DC, Continuous Tone / 12 V DC	36208	6	10-16
Cab Weldment	760010A	1	10-11
Cable, Camera System, 4PIN,49	1003907	23	10-11
Cam Follower, 3-1/4 "	811316	14	10-2
Camera,Color,Outdoor,12VDC	1003907	37	10-10
Camera Mount Brkt	1004383	27	10-10
Camera Mount Brkt	1004383	38	10-10
Camera Mount Brkt	1004383	24	10-11
Cap Screw, 1/2"-13 X 1.25 Hex	102-406-1A	46	10-11
Cap Screw, 1/2-13 X 1 Hex "	102-405-1A	16	10-9
Cap Screw, 1/2-13 X 2-1/2" Hex Head "	102-411-1A	22	10-10
Cap Screw, 1-8 X 2" Hex Head "	102-909-1A	24	10-10
Cap Screw, 3/8"-16 x 2.50 Hex	102-211-1A	41	10-11
Cap Screw, 3/8-16 X 1 Hex "	102-205-1A	12	10-20
Cap Screw, 3/8-16 X 1-1/2 Hex "	102-207-1A	14	10-8
Cap Screw, 3/8-16 X 1-1/4 Hex "	102-206-1A	18	10-8
Cap Screw, 3/8-16 X 6" Hex Head "	102-225-1A	14	10-20
Cap Screw, 5/16"-18 X 1.75 Hex	102-208-1A	48	10-11
Cap Screw, 5/8-11 X 2 Hex "	102-609-1A	17	10-8
Cap Screw, 5/8-11 X 2" Hex Head "	102-609-1A	23	10-10
Cap Screw, 5/8-11 X 2-1/2 Hex "	102-611-1A	12	10-8
Cap, Hyd. Oil Tank (Lockable)	140030HL	10	10-6
Cap, Radiator	988646-01	26	10-22
Chain Assy., Feeder	A710230	5	10-2
Chain Assy., Feeder L.H.(Paddle)	710230L556	5A	10-2
Chain Assy., Feeder R.H. (Paddle)	710230R556	5B	10-2
Circuit Breaker, 10A, Pan MT / Circuit Breaker	34964	1	10-15

Description	Part Number	Figure Number	Item Number
Circuit Breaker, 15A Pan MT	989260	4	10-15
Circuit Breaker, 30A, Pan MT	989261	2	10-15
Circuit Breaker,25A Pan MT / Circuit Breaker	35701	3	10-15
Clamp, 3 Muffler "	161250	1	10-20
Clamp, 3-1/4 Muffler "	750046	6	10-20
Clamp, Hose 3 Hole Complete Set	854748	21	10-9
Clamp, Insulated Band, 2 1/2"	148-232	10	10-22
Clamp, Muffler, 4.00 Id	34040	22	10-21
Clamp, T-Bolt, 3.00 Id	171090	23	10-21
Clamp, T-Bolt, 3.00 Id	171090	18	10-22
Clamp, T-Bolt, 3.50 Nominal	171190	19	10-22
Clamp, T-Bolt, 4.00 Id	953521243	13	10-21
Clamp, T-Bolt, 5.00 Id	72174	24	10-21
Clamp/3 Hole. Bottom Half	854748-B	22	10-9
Clamp/3 Hole. Top Half	854748-A	20	10-9
Clip, Hyd Cyl. Pin *	870307	15	10-9
Coil, 12 VDC	983643-02A	3	10-7
Complete Assembly	981386	1	10-9
Conn,21-Pin,Plug,HD Series	1002085	16	10-13
Conveyor Belt W / Cleats, 28' Frame	P202014	1	10-8
Conveyor Lift Cylinder	750610	5	10-9
Conveyor Stabilizer	981438	6	10-9
Cooler, Fan Only	36997	16	10-6
Cooler, Oil	35735	17	10-6
Cooler, Oil Assembly	1000516	15	10-6
Cotter Pin	870307	6	10-23
Coupling, Flywheel Pump Drive	P86879B	2	10-17
Cover	982072	21	10-12
Cover	982073	22	10-12
Cover	855132	5	10-19
Cover	988962-04	12	10-21
Cover Hoses	760021	2	10-11
Cover Plate, Valve	983643-11	—	10-7
Cover, Bogie Shaft	1001681556	32	10-24
Cover, Red	1003863	32	10-11
CP10-24	983643-04	7	10-7
CSHH, 3/4-10 X 3-3/4"	102-716-1A	5	10-10
CSHH,.375-16X1.50,GR5	102-207-1A	25	10-8
CSHH,.625-11X1.50,GR5 Cap Screw	102-607-1A	29	10-10
CSHH,.625-11X3.50,GR5 Cap Screw, 5/8-11 X 3-1/2 Hex	102-615-1A	5	10-13

Illustrated Parts List (IPL)



Description	Part Number	Figure Number	Item Number
CSHH,.625-11X4.00,GR5 Cap Screw, 5/8-11 X 4.00 Hex	102-617-1A	25	10-1
Cyl,Hyd 2.50X12.00,2500psi	640220	7	10-24
Cyl,Hyd Bucket Dump	1004241556	4	10-24
Cyl,Hyd,2,0Bx6.0s,W/Sensor	260060	10	10-24
Cyl,Hyd,3.50X10.00X1.75 Rod	700160-28	5	10-1
Cyl. Clevis 1.00X 2.75	1000284	14	10-9
Cylinder, Hydraulic	37293	3	10-23
Cylinder, Hydraulic	750610	7	10-6
CylinderSeal Kit	38550-01	—	10-6
CylinderSeal Kit	37620-05	—	10-6
Decal Kit	1000623	21	10-19
Deflector Lh	1004402556	25	10-24
Deflector Rh	1004403556	19	10-24
Defuser	1004577	34	10-10
Display, Graphic, B&W DP200 / DP-200	988699	5	10-15
Door	760062	6	10-11
Door Weldment	760062	1	10-12
Drive unit	1004426-06	8	10-3
Drive unit	1004426-06	8	10-4
Dust Ejection Valve	988962-03	14	10-21
EDC Controller	851545	7	10-17
Edge Trim	760070	4	10-12
Elbow W / Flex Pipe, 3000 Exhaust	750042	2	10-20
Elbow, Rubber, 60, 2.25 Id	984262	7	10-22
Elbow, Rubber, 90, 3.00 Id	34031	5	10-21
Elbow, Rubber, 90, 5.00X 4.00 Id	72172	7	10-21
Element, Fuel Filter, 4.5 Qsb	988666-04	5	10-18
Element, Oil Filter, 4.5 Qsb	988666-03	3	10-18
Element, Primary	988962-01	11	10-21
Element, Secondary	988962-02	10	10-21
Element,Hyd,Chg Filter	34464	-	10-17
Elevator Bolt, 1/4-20 X 1" "	P521452	9	10-10
Engine, Cummins, 152HP, T3	1003900	1	10-17
Fan, Multi Wing. 22" Dia	988934	1	10-18
Filler Neck, Hyd. Oil / Fuel Cap	140030FN	3	10-6
Filter Element, Fuel/Water Separator	988666-05	7	10-18
Filter, Air Pre-Cleaner	852060	17	10-21
Flashing, 25X6.0 X 34. Main (Not Shown)	750241A		10-9
Flat Washer, 1/2" SAE	119-5	44	10-11
Flat Washer, 3/8" SAE	119-3	40	10-11

Description	Part Number	Figure Number	Item Number
Flat Washer, 3/8" SAE	119-3	47	10-11
Flat Washer, 3/8" SAE	119-3	53	10-11
Flat Washer, 3/8" SAE	119-3	55	10-11
Flat Washer, 7/16" SAE	119-4	26	10-10
Flow Divider CP10-4L	983643-10	10	10-7
Foam - Door	982061	7	10-12
Frame Window	760170	21	10-11
Fuel Tank Cap, Lockable	140030FL	5	10-6
Gas Shock, Engine Back Door	853600	12	10-19
Gasket, S.A.E. B" 2 Bolt "	700480	2	10-2
Gasket, S.A.E. C" 4 Hole "	P77494	20	10-10
Gauge, Hyd. Oil Level & Temp.	500070	9	10-6
Glass - Door	760080	2	10-12
Grease Fitting, 1/4" X 28 Screw In	140610	25	10-2
Grill	750554SRV	27	10-22
Grommet, Tail Lamp Mounting	160030A1	15	10-19
Group, Engine Hood Loader	988753	6	10-19
Group, Tank, Hydraulic	1004370	11	10-6
Group, Tank. Fuel	1004253	2	10-6
Grp,Engine Hood,Loader	988753	18	10-19
Hairpin Cotter Pin	7303	29	10-24
Handle Nut,.625-11	300060	24	10-1
Harness, Plus 1,Sand Shark	1003851	9	10-16
Harness, TOPCON, Curly Cord, Modified, Sand Shark	1004565	29	10-1
Harness, Topcon, Curly Cord, Sand Shark	1004565	11	10-13
Hfbolt 0.3125-18X2.25x0.875-N	80214	5	10-24
Hinge,3000,Loader,Cab	760101	10	10-11
Hose, 04, Push-On, 3.0 Ft Lg	32882-01	23	10-22
Hose, 05. Push-On, 3.0 Ft Lg	71812-01	24	10-22
Hose, Radiator, Lower	170100A	6	10-22
Hose, Radiator, Upper 685B/3000	170071A	9	10-22
Hose,Defroster	P52281	37	10-11
Hose,Heater, .625	TF10199	38	10-11
Hub, Wheel Complete #W45-8	36136	34	10-24
Hump Hose, Reducer, 5.00-4.00 Id	953521244	16	10-21
Hx-Shcs 0.5-20X1.125x1.125-N	80387	11	10-24
Hx-Shcs 0.5-20X1.125x1.125-N	80387	38	10-24
Hyd. Motor, Feeder Drive, 3000	710100	1	10-2
Hyd. Motor, Main Conveyor Drive	750310	21	10-10
Hyd.Cyl.,Discharge Baffle	P521124	1	10-10

Illustrated Parts List (IPL)



Description	Part Number	Figure Number	Item Number
Hydraulic Cylinder	37293	14	10-6
Idler with track adjuster	1004426-03	4	10-3
Idler with track adjuster	1004426-03	4	10-4
Indicator, Air Filter	171220	21	10-21
Int. Handle & Bezel- Rh	982063	10	10-12
Interior Handle	982060	5	10-12
J. Bracket Main Conveyor	854741	4	10-9
Joystick	987134-02	3	10-14
Key Vandalism	35560	28A	10-22
Key, Door	760010A-02	25	10-12
Key, Vandalism Lock	35560	4A	10-19
Key, Vandalism Lock	35560	20	10-19
Key. Ignition,Kubota, 300B,635/Order 1 Receive 2Keys	982008-04	9A	10-15
Keystock,Sq.,.375X1.75	857137	23	10-8
Keyway, Paddle Conveyor	710171-2	9	10-2
Kit, Lacing Repair	P202014-01	1A	10-8
Kit,A/C/Heat,3000	853700	35	10-11
Kit,Bolt Cutting Edge	1004616	31	10-1
Latch - Smc Modified - Rh	982062	9	10-12
Latch Rod, Lh	982065	12	10-12
Latch, Engine Access Panel	160450	4	10-19
Latch, Goose Neck, 2 -5/16"	1004191556	1	10-24
Latch, Radiator Access Panel	160460	19	10-19
Latch, Radiator Access Panel	160460	28	10-22
LH side frame		1	10-3
Light Mounting Brkt	1004383	26	10-11
Light, 5', Tractor	1003862	31	10-11
Light, Mount Brkt	1004383	31	10-10
Light, Tail, Red	160030A	13	10-19
Light,Amber, Dash, 50 Hole	1001625	1	10-14
Light,Halogen,Trap,55 Watt	160040A	36	10-10
Light,Halogen,Trap,55 Watt	160040A	25	10-11
Light,Halogen,Trap,55 Watt	160040A	14	10-19
Link & Pin Assy., Feeder Chain (2800/3000)	710230-1	5C	10-2
Link, Top Rad Gusset	988748	2	10-22
Loader, Rear Connection	1004233	1	10-23
Lock Nut, 3/8-16 Hex "	143-3	16	10-8
Lock Trip Rod - 5/32 Dia. - Cntr	982070	17	10-12
Lock Washer, 3/8"	118-3	50	10-11
Lock Washer, 3/8"	118-3	57	10-11

Description	Part Number	Figure Number	Item Number
Locking Collar, 2-1/2 I.D. "	120120	12	10-2
Locknut, 3/8"-16	143-3	39	10-11
Locknut, 3/8"-16 Hex	143-3	52	10-11
Locknut, 3/8"-16 Hex	143-3	56	10-11
Lockwasher, 1/2"	118-5	45	10-11
Manifold, Hyd 13 station Sand Shark	1004108	1	10-7
Master Bushing	1004426-26	11	10-5
Mirror Head, West Coast	852570	29	10-11
Mirror, Outside Rearview	151370	28	10-11
Motor	1004102	39	10-24
Motor Mount	854788	18	10-10
Motor Mount,LH	981778	5	10-17
Motor Mount,RH	750581	6	10-17
Motor, Drive 18T	989183	18	10-3
Motor, Drive 18T	989183	18	10-4
Motor,Windshield Wiper	151170	3	10-13
Mount Block Assembly Pivot	982765	22	10-1
Mount, Light, Mirror	856987	30	10-11
Mount, Torque Hub	854932	4	10-2
Mounting Bar, Mirror	985624	42	10-11
Mounting Bar, Mirror Group	856896	43	10-11
Mounting Bracket, Mirror	856987	51	10-11
Mounting Bracket, Mirror	856987	54	10-11
Mounting Pad	320140	4	10-17
Muffler, 3000 Exhaust	750043	3	10-20
Number 36, Hose Clamp	500230	21	10-22
Number 4, Hose Clamp	33277	25	10-22
Nut 1"	80009	32	10-2
Nut, 1/2 "	116-5	19	10-9
Nut, 3/4-10 Hex "	116-8	10	10-8
Nut, 3/4-10 Hex "	116-8	7	10-10
Nut, 3/8"-16 Hex	116-3	34	10-11
Nut, 3/8"-16 Hex	116-3	49	10-11
Nut, 3/8-16 Hex "	116-3	13	10-20
Nut, Coil	983643-03	4	10-7
Nut,Hex,.437-14	116-4	28	10-10
Nut,Hex,.625-11	116-7	33	10-10
Nut,Hex,Jam,.625-11 nut, 5/8"-11 Hex Jam	116-7-1	7	10-13
O.S. Paddle Handle - Rh	982064	11	10-12
O-Ring	980493	11	10-17

Illustrated Parts List (IPL)



Description	Part Number	Figure Number	Item Number
O-Ring, Tandem/Gearbox	984992	8	10-17
Paddle Bearing Plate	854946A	27	10-2
Paddle Roller Spacer / 3000	854953	14A	10-2
Paddle Shaft Stop	854955	23	10-2
Paddle, Motor Mount Slide Panel Side	854933 760031	24 3	10-2 10-11
Pin, 1" OD x 5.25"	980167SRV	5	10-23
Pin, Clevis	210060	3	10-10
Pin, Conveyor Belt Lacing (30") W/O Metal Tips	750080	2	10-8
Pin, Cotter	28747	15A	10-24
Pin,Bucket Lift	1004416	21	10-24
Pin,Bucket Lift	1004417	22	10-24
Pin,Clevis 1.00 X 3.25 W 3 Holes	1004423	28	10-24
Pin,Cotter,.156X2.50	81019	18	10-6
Pipe, 3000 Exhaust Stack	750047	7	10-20
Pipe, Air Intake, 4.00X54.00	1000723	4	10-21
Pivot Mount, TOPCON/Spectra	851575SRV	15	10-1
Pl, Cover, Air Cleaner, 3000	1000707	20	10-21
Plate W / Clamps, 3000 Muffler Mount	750048	9	10-20
Plate, 3000 Muffler Heat Shield	750045	5	10-20
Plate, Frame Side Left 3000	1000557	8	10-19
Plate, Frame Side Right 3000	1000556	7	10-19
Plate, Hydraulic Output	980286	—	10-7
Plate,Bent,Radiator Hose Bracket	1004599	20	10-22
Plate,Bent,Radiator Hose Bracket	1004599	29	10-22
Plate,Cutting Edge Gauge,Top	1004486	18	10-1
Plate,Decal Plate	1004487	17	10-1
Plate,Moldboard Widener,RH	1004726	3	10-1
Plug	987220-01	—	10-7
Plug	987220-02	—	10-7
Plug, 3/4, Button, Nylon, Black	982076	24	10-12
Plug, CP08-20	987220-05	6	10-7
Plus-One Controller (Controls, 50 Pin) Generic	1003456	8	10-16
Polyurethane Seal	1004426-18	3	10-5
Potentiometer, 100 Ohm / Potentionmeter	35050	2	10-16
Pulley, Head Drum W/Lag	750260	13	10-10
Pulley, Sifter Drive	1004847	41	10-24
Pump Drive,Dual,3000	P76869A	3	10-17
Pump Drive,Hyd,Double Drive	980400	9	10-17
Pump,Gear Charge	980500	13	10-17

Description	Part Number	Figure Number	Item Number
Pump,Hyd,Load Sense,38CC	980490	12	10-17
Pump,Variable	980470	10	10-17
Rad/Cac/Oil Cooler	988646	1	10-22
Rain Cap, 3" Exhaust Pipe	750041	*8	10-20
Reducer	982780	12	10-22
Reducer, Rubber, 3.00 Id/4.00 Od	1000575	3	10-21
Remote , Signal	36150	5	10-16
Rh I/S Trip Rod	982068	15	10-12
RH side frame		1	10-4
Rock guard	1004426-04	6	10-3
Rock guard	1004426-04	6	10-4
Rod, Paddle Chain Adjuster	750549SRV	7	10-2
Rod,Cutting Edge Gauge	1004485	19	10-1
Roller Assy (30 Degree), Conveyor Troughing	750130	21	10-8
Roller Assy(15 Degree), Conveyor Troughing	750131	20	10-8
Roller Assy.(25 Degree), Conveyor Troughing	986341	22	10-8
Roller Assy., Conveyor Return Idler	750090	3	10-9
Roller Assy., Conveyor Return Idler	750090	7	10-9
Roller, 2800 / 3000 Troughing Idler	750140	2	10-9
Scraper, 3000 Tail Pulley	750062	13	10-8
Seal	760090	13	10-11
Seal	210240	20	10-2
Seal Door	760070	7	10-11
Seal Front	760090	17	10-11
Seal Kit	38922-01		10-10
Seal Kit	37620-05	-	10-23
Seal Kit	1004102-01		10-24
Seal Rear	760090	15	10-11
Seal Side	760090	20	10-11
Seal Window	760090	9	10-11
Seal Window	760180	22	10-11
Seat Assy,Black,W/Armrest	360010B	1	10-13
Sender, Temperature Gauge	35368	12	10-6
Sending Unit, Fuel Level	140040	4	10-6
Sensor, Coolant Level	988986	5	10-22
Shaft, 2800 / 3000 Conveyor Head Pulley	750271	15	10-10
Shaft, 3000 Feeder Lower	710221A	22	10-2
Shaft, 3000 Feeder Upper Drive	710171A	8	10-2
Shaft, 3000 Main Conveyor Tail Pulley	750032	6	10-8
Shaft, Main Conveyor Support	171231	9	10-19

Illustrated Parts List (IPL)



Description	Part Number	Figure Number	Item Number
Shield, Loader Bucket	1003919	11	10-10
Side Plate, Back Left Side	854801	11	10-9
Side Plate, Back Right Side	854797	10	10-9
Side Plate, Center Left Side	854798	12	10-9
Side Plate, Center Right	854799	9	10-9
Side Plate, Front Left Side	854796	13	10-9
Side Plate, Front Right	854795	8	10-9
Sifter,Remote Control, Transmitter/Receiver	1004229	15	10-13
Snap Ring, Conveyor L.H. Bearing Retainer	750323	16	10-10
Socket, Door, Stop	P527323	11	10-11
Solenoid Valve	983643-01	2	10-7
Solenoid Valve	1004108-02	—	10-7
Solenoid Valve SV12-28	720290	11	10-7
Solenoid,12V,Constant Duty/ 635B/685 Instrument Panel	720290	14	10-15
Spacer	1004426-24	9	10-5
Spacer Tube, 3000 Exhaust Heat Shield	856999	4	10-20
Spacer, Guide Wheel	1004438	8	10-1
Spacer, Guide Wheel	1004439	10	10-1
Spacer,Guide Wheel Assy	1004724	11	10-1
Spacer,Wheel 3000SS	1004387	36	10-24
Sprocket	1004426-01	2	10-3
Sprocket	1004426-01	2	10-4
Sprocket, 3000 Feeder Chain Lower (Paddle)	855066	19	10-2
Sprocket, Feeder Chain Upper Paddle Dr	710182	10	10-2
Starter, Denso. R2.7	988666-02	4	10-18
Strainer & Gasket Kit, Hyd./ Fuel Filler	140030GK	6	10-6
Strobe Light, Amber	211748-02	33	10-11
Suspension Bracketry,Seat, Low	140600	4	10-13
Switch and Indicator	REF ONLY	13	10-13
Switch, E-Stop, Base W/ Button	988924-10	7	10-16
Switch, Ignition w/ Heat ST / Kubota	39146-14	9	10-15
Switch, Low Hyd. Oil Level	981357	8	10-6
Switch, Push Button	982249	8	10-15
Switch, Toggle Spot,2POS Toggle Sw. (3Pole)	851090624	2	10-14
Switch, Toggle Spot,2POS Toggle Sw. (3Pole)	851090624	4	10-14
Switch, Toggle, 2-Pos, Spdt, Toggle Switch (3 POS)	851090624	7	10-15
Switch, Toggle, 3-Pos, Spdt, Mom	851392	4	10-16
Switch, Toggle, 3-Pos, Spdt, Mom	851392	6	10-15
Switch, Toggle, Spdt, 3-Pos, Mom	851392	3	10-16
Switch, Toggle, SPST,2-Pos, 2 Speed High/Low	851391	10	10-15

Description	Part Number	Figure Number	Item Number
Switch, Wipper/ Washer (3000)	853090	12	10-15
Switch. Toggle, SPDT, 2 -POS / Toggle Sw (3Ploe)	851090624	1	10-16
Tail Light Box,LH	981565	17	10-19
Tail Light Box,RH	981564	16	10-19
Tail Pulley, Winged 2800/3000	750060	7	10-8
Tank, Radiator Overflow	983273	22	10-22
Tank,Windshield Wiper Washer	151200	13	10-15
Taper Lock Bushing, 2 1/2 "	710150-28	11	10-2
Terminal Block, 10 Gang	987982	15	10-15
Tire And Rim	100391655W	37	10-24
Top Roller	1004426-05	7	10-3
Top Roller	1004426-05	7	10-4
Topcon V Control	983414-02	10	10-13
Torque Hub, 2800 / 3000 Conveyor Drive	750300	19	10-10
Torque Hub, Feeder Drive	710090-28	3	10-2
Track bushing	1004426-20	5	10-5
Track chain assembly	CR5985/46/500	5	10-3
Track chain assembly	CR5985/46/500	5	10-4
Track link LH	1004426-16	1	10-5
Track link RH	1004426-17	2	10-5
Track Pin	1004426-19	4	10-5
Track Pin Master	1004426-25	10	10-5
Track roller	1004426-02	3	10-3
Track roller	1004426-02	3	10-4
Track Shoe 500mm wide	1004426-23	8	10-5
Track Shoe Bolt	1004426-22	7	10-5
Track Shoe Nut	1004426-21	6	10-5
TSD Sonic Tracker II	983414-01	12	10-1
Tube, Bent Air Intake, 3.00 Od	1000500	1	10-21
Tube, Bent Air Intake, 3.00 Od	1000501	2	10-21
Tube, Bent, Charge Air, 3.00 Od	1000504	11	10-22
Tube, Bent, Charge Air, 3.00 Od	1000502	14	10-22
Tube, Bent, Charge Air, 3.00 Od	1000503	15	10-22
Tube, High Temp, 3" Id X 4"L, Str	987281	6	10-21
Tube, High Temp, 3"Id X 4"L, Str	987281	13	10-22
Tube, Rnd, 2.25Od X 2.00ld X3.00 Lg	42541	8	10-22
Tube, Sleeve, Loader Air Cleaner	1000862	18	10-21
Tube, Spindle Pin Stop	1004422	8	10-24
Tubing,Guide Wheel	1004378	6	10-1
Turnbuckle	P526113	13	10-24

Illustrated Parts List (IPL)



Description	Part Number	Figure Number	Item Number
Valve	1004426-11	13	10-3
Valve	1004426-11	13	10-4
Valve, Check	983643-08	9	10-7
Valve, Check	987220-03	—	10-7
Valve, Check	988657-01	—	10-7
Valve, Check PC10-30	986992-03	12	10-7
Valve, Counterbalance CBCA-LNN	987220-07	13	10-7
Valve, Dual Check	983643-05	8	10-7
Valve, Reducing CP08-30	1004108-03	5	10-7
W/M Hitch Drawbar	1004794SRV	2	10-23
W/M Main Frame, 3000SS	1003826	1	10-6
W/M, Air Intake Stabilizer, 3000	1000721	19	10-21
W/m, Deflector Mount	1004581	8	10-10
W/m, Defuser	1004580	35	10-10
W/M, Frt Rad Mount	988759	3	10-22
W/M, Rear Rad Mount	988762	4	10-22
W/M,Auger Box Side, LH	1004701	2	10-1
W/M,Auger Box Side, RH	1004702	1	10-1
W/M,Lever Height Gauge	1004054	21	10-1
W/M,Moldboard Tension Bar	1004790	23	10-1
W/M,Widener With Guide Brkt,LH	1004730	4	10-1
W/M. Engine Cover Loader	1000072	1	10-19
W/M. Engine Door Rh	986742	10	10-19
W/M. Engine Side Cover Lh	988813	3	10-19
W/M. Engine Side Cover Rh	988812	2	10-19
Washer	1004426-07	9	10-3
Washer	1004426-10	12	10-3
Washer	1004426-12	14	10-3
Washer	1004426-07	9	10-4
Washer	1004426-10	12	10-4
Washer	1004426-12	14	10-4
Washer 1"	119-10	33	10-2
Washer, 1 Lock "	118-10	24B	10-10
Washer, 1 S.A.E. Flat "	119-10	24A	10-10
Washer, 1/2 Lock "	118-5	22B	10-10
Washer, 1/2 S.A.E. Flat "	119-5	22A	10-10
Washer, 3/8 Lock "	118-3	19	10-8
Washer, 3/8 Lock "	118-3	11	10-20
Washer, 3/8 Sae Flat "	119-3	15	10-8
Washer, 3/8 Sae Flat "	119-3	10	10-20

Description	Part Number	Figure Number	Item Number
Washer, 5/8 Lock "	118-7	11	10-8
Washer, 5/8 Lock "	118-7	23B	10-10
Washer, 5/8 S.A.E. Flat "	119-7	23A	10-10
Washer, Flat 1/2 "	119-5	17	10-9
Washer, Lock 1/2 "	118-5	18	10-9
Washer,FLAT,SAE,.625	119-7	32	10-10
Washer,Flat,SAE,.625 Flat	119-7	26	10-1
Washer,Flat,SAE,.625 Flat Washer, 5/8" SAE	119-7	6	10-13
Washer,Lock,.375	118-3	24	10-8
Washer,Lock,.437	118-4	25	10-10
Washer,Lock,.563	118-6	30	10-10
Wearplate,Plastic,Sand Shark Cutting Edge	1004430	30	10-1
Weather Boot, toggle Switch/ (Long)	851441	11	10-15
Weldment,Bucket	1004196556	3	10-24
Weldment,Cutting Edge	1003910SRV	27	10-1
Weldment,Dump Arm	1004118	2	10-24
Weldment,Motor Mount	1004254556	17	10-24
Weldment,Tandum Axle	1004151556	35	10-24
Wheel, Guide Wheel	1004372	9	10-1
Window	760130	14	10-11
Window Assembly	760150	18	10-11
Window Door	760080	8	10-11
Window Front	760140	16	10-11
Window Right	760160	19	10-11
Window Right Side	760120	12	10-11
Windshield Seal	760090	3	10-12

NOTES

LeeBoy



VT LeeBoy

A company of VT Systems

500 Lincoln County Parkway Ext.

Lincolnton, North Carolina 28092

Phone: (704) 966-3300 - Fax Sales: (704) 483-5802

www.leeboy.com

Printed in the U.S.A.