

LeeBoy

PARTS MANUAL



7000 Conveyor Paver

Manual No. 7000102

USER'S REFERENCE INFORMATION

DELIVER DATE _____

EQUIPMENT SERIAL NO. _____

TYPE ENGINE _____

ENGINE NO. _____

DEALER'S NAME & ADDRESS

EQUIPMENT HOURS _____

SAFETY NOTICE

All danger points about the 7000 are explained and labeled by decals to the best of our knowledge. If anyone in the field discovers anything omitted, please notify your closest dealer or factory.

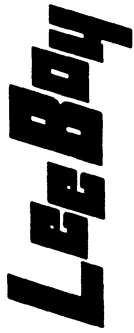

ONE YEAR LIMITED WARRANTY

EFFECTIVE FOR UNITS SHIPPED AFTER DECEMBER 1, 2001

LeeBoy
688 North Highway 16
Denver, North Carolina 28037
www.LeeBoy.com

WARRANTY

1. If a defect in material or workmanship is found and the authorized dealer is notified during the warranty period, LeeBoy will repair or replace any part or component of the unit or part that fails to conform to the warranty during the warranty period.
2. The warranty date will begin upon the completion of the warranty form by the initial customer and will expire after twelve (12) months have passed. The Warranty Card should be filled out within (10) days of delivery of the unit.
3. Engines are warranted by their manufacturers and may have warranty coverage that differs from that of LeeBoy.
4. Replacement parts furnished by LeeBoy are covered for the remainder of the warranty period applicable to the unit or component in which such parts are installed.
5. LeeBoy has the right to repair any component or part before replacing it with a new part.
6. All new replacement parts purchased by a LeeBoy dealer will carry a six (6) month warranty. Remanufactured parts purchased by a LeeBoy dealer will carry a ninety (90) day warranty.

LIMITATIONS

LeeBoy has no obligation under this warranty for:

1. Any defects caused by misuse, misapplication, negligence, accident or failure to maintain or use in accordance with the most current operating instructions.
2. Unauthorized alterations.
3. Defects or failures caused by any replacement parts or attachments not manufactured by or approved by LeeBoy.
4. Failure to conduct normal maintenance and operating service, including without limitation, providing lubricants, coolant, fuel, tune-ups, inspections or adjustments.
5. Unreasonable delay, as established by LeeBoy, in making the applicable units or parts available upon notification of a service notice ordered by LeeBoy.

6. The warranty responsibility on all engines rests with the respective manufacturer.
7. LeeBoy may have support agreements with some engine manufacturers for warranty and parts support.

ITEMS NOT COVERED

LeeBoy is not responsible for the following:

1. Charges for travel time, mileage, or overtime.
2. Charges related to transporting the product to and from the place at which warranty work is performed.
3. Airfreight charges related to transporting repair parts to the place at which warranty work is performed.
4. All used units or used parts of any kind.
5. Repairs due to normal wear and tear, or brought about by abuse or lack of maintenance of the equipment, except for premature failures, conveyor chains, polytrack pads, and track rails.
6. Attachments not manufactured or installed by LeeBoy.
7. Liability for incidental or consequential damages of any type, including, but not limited to lost profits or expenses of acquiring replacement equipment.
8. Miscellaneous charges.

OTHER WARRANTIES

THE FOREGOING WARRANTY IS EXCLUSIVE AND IN LIEU OF ALL OTHER EXPRESSED, STATUTORY AND IMPLIED WARRANTIES APPLICABLE TO UNITS, ENGINES, OR PARTS WITHOUT LIMITATION, ALL IMPLIED WARRANTIES OF MERCHANTABILITY OR FITNESS FOR ANY PARTICULAR USE OR PURPOSE. IN NO EVENT, WHETHER AS A RESULT OF BREACH OF CONTRACT OR WARRANTY, OR ALLEGED NEGLIGENCE OR LIABILITY WITHOUT FAULT, SHALL LEEBOY BE LIABLE FOR SPECIAL, INCIDENTAL OR CONSEQUENTIAL DAMAGES, INCLUDING WITHOUT LIMITATION, LOSS OF PROFIT OR REVENUE, COST OF CAPITAL, COST OF SUBSTITUTED EQUIPMENT, FACILITIES OR SERVICES, DOWNTIME COSTS, LABOR COSTS OR CLAIMS OF CUSTOMERS, PURCHASERS OR LESSEES FOR SUCH DAMAGES.

Index

GENERAL STATEMENT.....	1
IMPORTANT SAFETY INSTRUCTIONS	2
SAFETY PRECAUTIONS	3
SPECIFICATIONS	4
SAFETY PRECAUTIONS AND GENERAL INFORMATION.....	5
PRE-START INSPECTION.....	5
OPERATING SAFETY	5
STOPPING SAFETY	5
MAINTENANCE SAFETY	5
CONTROLS AND DESCRIPTIONS	6 & 7
STARTING THE ENGINE	8
PRELIMINARY	8
ENGINE/START-UP	8
STOPPING THE ENGINE (Diesel Engine).....	8
PAVER DRIVING INSTRUCTIONS	8
TRUCK HITCH ATTACHMENT (OPTIONAL).....	9
PAVER PREPARATION INSTRUCTIONS.....	10
BURNER IGNITION PROCEDURES	10
IF BURNERS DON'T IGNITE	10
MANUAL LIGHTING OF BURNERS.....	11
OPERATING FEEDER	12
OPERATION OF ELECTRIC FLIGHT SCREW.....	13
USE OF AUGER EXTENSIONS.....	13
OPERATION OF HYDRAULIC CUTOFFS	14
ELECTRIC SPRAYDOWN.....	14
AUTOMATIC AUGER.....	14
AUTOMATIC AUGER: NEW STYLE (Tied in with Conveyors)	15
HOW TO OPERATE	15
LOADING AND UNLOADING	16
TIE DOWN PROCEDURES.....	17
PAVER PREPARATION INSTRUCTIONS	18
STARTING TO PAVE	18
SETTING SCREED TO PAVE	19
SETTING SCREED ENDGATES.....	20
SETTING SCREED EXTENSIONS (Used When Paving Over 8 Feet)	21
PAVER OPERATION	21
ROUTINE MAINTENANCE	
10 - HOUR OR DAILY ROUTINE MAINTENANCE	22
50 - HOUR OR WEEKLY ROUTINE MAINTENANCE	22
100 - HOUR OR MONTHLY ROUTINE MAINTENANCE	23
250 - HOUR OR QUARTERLY ROUTINE MAINTENANCE	24
500 - HOUR OR SEMI-ANNUAL ROUTINE MAINTENANCE.....	24
1000 - HOUR OR ANNUAL ROUTINE MAINTENANCE	24

Index (Continued)

LUBRICATION CHART	25
MAINTENANCE ADJUSTMENTS	26
TO RAISE FEEDERS	26
LOWERING FEEDERS	27
FEEDER FLIGHT CHAIN ADJUSTMENT	27
AUTOMATIC TRACK ADJUSTMENT	27
DIRECTIONAL CONTROL ADJUSTMENTS	28
FORWARD OR REARWARD (CABLE CORRECTION)	28
FEEDER DRIVE CHAIN	28
AUGER DRIVE CHAIN	28
CONVEYOR LIMIT SWITCH	29 & 30
ELECTRIC DIAGRAM FOR 7000 PAVER	31
HYDRAULIC DIAGRAM FOR 7000 PAVER	32
TRUBLE SHOOTING GUIDE.....	33 & 34

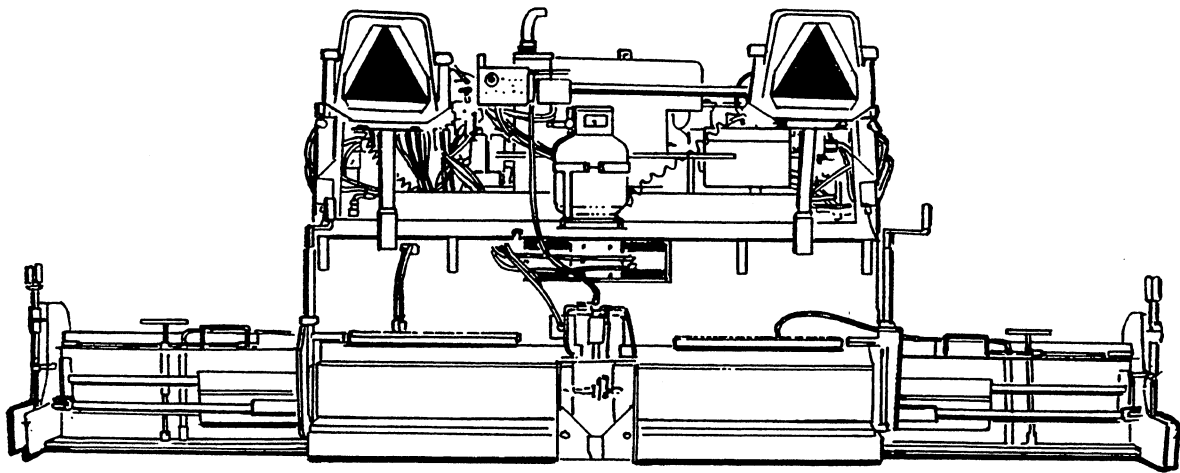

REAR VIEW

**MODEL
7000
LOW DECK
ASPHALT PAVER
OPERATORS,
MAINTENANCE
AND PARTS MANUAL**

This manual should be used with all related supplemental books, engine and transmission manuals, and parts books. Related Service Bulletins should be reviewed to provide information regarding some of the recent changes.

If any questions arise concerning this publication or others, contact your local Lee-Boy Distributor for the latest available information.

Contents of this manual are based on information in effect at the time of publication and are subject to change without notice.

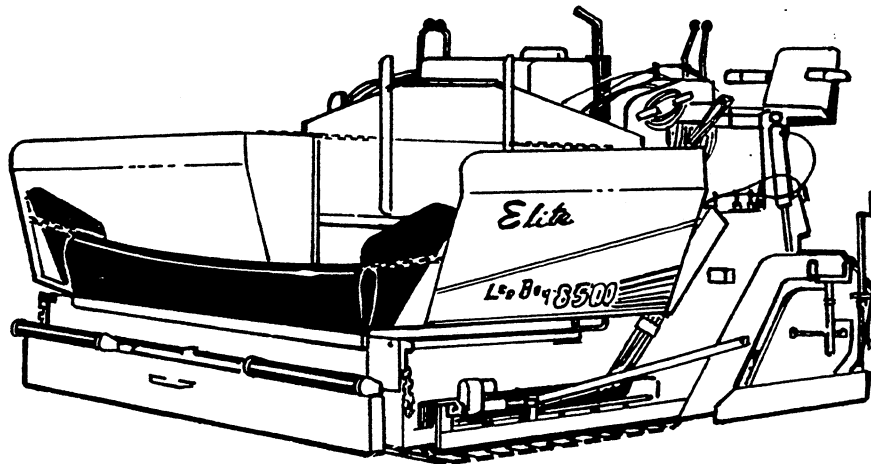

FRONT 3/4 VIEW

IMPORTANT SAFETY INSTRUCTIONS

This manual provides important information to familiarize you with safer operating and maintenance procedures. Even though you may be familiar with similar equipment, you **MUST** read and understand this manual before operating this unit.

Safety is everyone's business and is one of your primary concerns. Knowing the guidelines covered in the following paragraphs and in Section 1 will help provide for your safety, for the safety of those around you, and for the paver's proper operation.

LOOK FOR THESE SYMBOLS WHICH POINT OUT ITEMS OF EXTREME IMPORTANCE TO YOU AND YOUR CO-WORKERS SAFETY. READ AND UNDERSTAND THOROUGHLY. HEED THE WARNING AND FOLLOW THE INSTRUCTIONS.

! DANGER !

YOU MUST FOLLOW ALL DANGER SAFETY NOTES. IF YOU DO NOT FOLLOW THE INSTRUCTIONS, YOUR MISTAKE MIGHT LIKELY RESULT IN VERY SERIOUS INJURY OR DEATH.

! WARNING !

WARNING safety notes must **ALSO** be followed. Your mistake might result in **SERIOUS INJURY** to yourself or others.

! CAUTION !

CAUTION safety notes are **ALSO** very important. They point out to you where your mistakes could cause **PHYSICAL HARM** to you or others or damage to the machine.

SAFETY PRECAUTIONS

If your paver has been repainted, it is extremely important that all the decals referring to cautions, warnings and danger be replaced in their proper locations. The illustrations on this page will aid you in determining the proper locations, however, for additional help, you should refer to the part listing in the parts section of this manual and note the description column. Under this column a description on location is provided for each decal. If you still need more explicit instructions, contact your dealer.

! IMPORTANT ! ! IMPORTANT !

It is the responsibility of the owner and operator to make sure that all decals are readable and located on paver as designated by manufacturer.

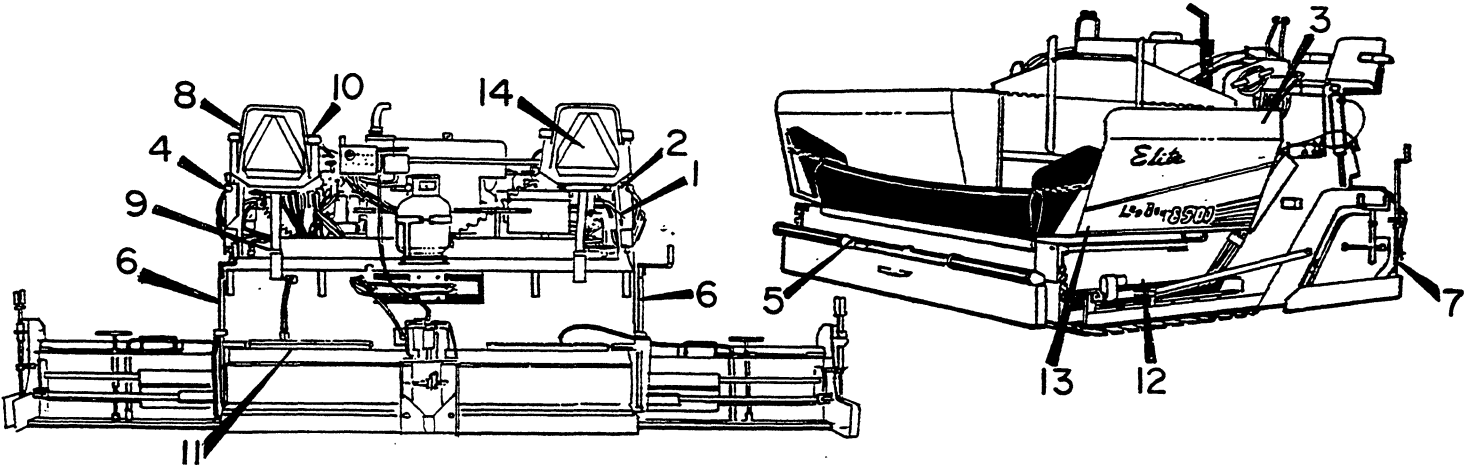

DANGER
DO NOT FILL FUEL TANK WHILE ENGINE IS RUNNING OR SCREED IS BEING HEATED

WARNING
DO NOT USE
ELECTRIC SPRAY SYSTEM WHEN BURNERS ARE IN USE

DANGER
PINCH POINT

WARNING
HYDRAULIC OIL
ONLY
KEEP CLEAN

SAFETY
LIP PROP

1

2

3

4

5

CAUTION
FLIGHT SCREW HANDLE MUST BE IN LOCKED POSITION WHEN RAISING SCREED.
DAMAGE COULD OCCUR TO HAND, SEAT OR SCREW IF NOT LOCKED. ALWAYS REMOVE HAND WHEN RAISING SCREED.

WARNING:
HOT FLAMMABLE
HEAT COMING OUT END OF SCREED COULD BURN OR CATCH CLOTHING ON FIRE IF NOT CAREFUL. NEVER SPRAY FUEL OIL ON SCREED WHEN BURNERS ARE ON.

WARNING
ALWAYS FOLD SIDEWINGS ON HOPPER OUT BEFORE RAISING CONVEYOR.

DANGER
Keep Hands & Clothing Clear of Augers & Conveyors

9

8

6

DANGER
PINCH POINT

DANGER
Always Keep Guidebar Latched While in Transit (Keep All Adjustments Tight)

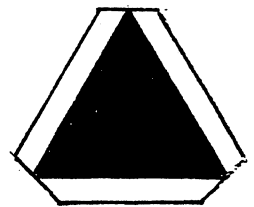

14

DO NOT OPERATE OR TOW THIS MACHINE WITHOUT FIRST FULLY UNDERSTANDING THE CONTENTS OF THE OPERATORS MANUAL.

11

GREASE TO ADJUST TRACKS
CAUTION
USE HAND GREASE PUMP ONLY DO NOT OVERGREASE, STOP PUMPING AT FIRST SIGN OF BACK PRESSURE

13

12

10

SPECIFICATIONS

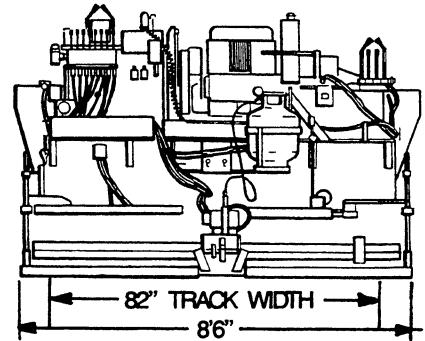
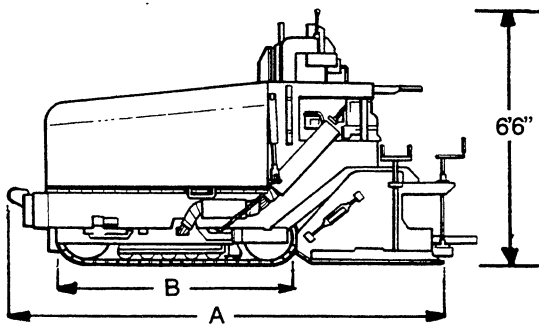

7000 ELITE SHOWN

	7000
Overall Length "A"	12'4"
Overall Height	6"
Overall Width (Hopper Wings In)	8'6"
(Hopper Wings Out)	9'6"
Weight	12,000 lbs.
CAPACITIES:	
Fuel Tank	13 Gals.
Hydraulic Reservoir	40 Gals
Hopper	6 Tons
ENGINE:	
56 HP Silent Pack Diesel	Standard
Paving Speed (Track)	140 FPM
Travel Speed (Track)	220 FPM
Lee-Boy Tracks "B"	Standard
Basic Screed Width	8 feet
Maximum Paving Width Standard	13 feet
Electric Thickness Screws	Standard
Electric Spraydown	Standard
Vibratory Screed	Standard
Twin Automatic Conveyors	Standard
Automatic Augers	Standard
Electric Igniters	Optional
Hydraulic In Wheel Truck Hitch	Optional
Roll Up Curbing Attachment	N/A
Automatic Joint Matcher	Optional
Automatic Grade & Grade	Optional
Automatic Grade & Slope	Optional

SAFETY PRECAUTIONS AND GENERAL INFORMATION

PRE-START INSPECTION

INSPECT machine. Have any malfunctioning, broken or missing parts corrected or replaced before using. Hydraulic hoses should be checked daily for wear and leaks. Replace if damaged.

CHECK that all the instruction and safety labels are in place and readable. These are as important as any other equipment on the machine.

READ and FOLLOW all instruction decals.

WEAR OSHA required safety equipment when running the paver.

FILL the fuel tank with the engine off. Never fill near an open flame, when smoking or when screed heat is on.

CLEAR auger & feeders before starting engine. Make sure all covers and guards are in place.

OPERATING SAFETY

ALWAYS make sure no person or object is in your line of travel BEFORE starting.

WORK slowly in tight areas.

DO NOT run engine in a closed building for long periods of time. NEVER spray fuel oil on or near screed while it is being heated.

AVOID steep hills if possible

DO NOT shift transmissions on steep grades.

ALWAYS look BEFORE changing your direction of travel.

NEVER open a valve to burner unless a flame is present. Heat screed for no more than 5 minutes. Make sure all valves are closed after burner is turned off.

AVOID leaving engine running without operator present.

STOPPING SAFETY

ALWAYS park the paver on solid, level ground, in low range. IF this is not possible, always park the paver at a right angle to the slope. Lower screed when parked.

USE proper flags, barriers and warning devices especially when parking in areas of traffic.

MAINTENANCE SAFETY

AVOID working on the paver with the engine running.

NEVER fill the fuel tank with the engine running.

DO NOT change the engine governor settings.

ALWAYS replace damaged or lost decals.

DISCONNECT battery cables when working on the electrical system or when welding on the unit.

IF battery needs a charge be sure battery charger is off when making connections.

BE SURE the correct battery polarity is observed (negative (-) to negative (-) and positive (+) to positive (+)) when connecting a battery charger or jumper cable.

! DANGER !

NEVER WORK UNDER HOPPER WITHOUT PLACING SAFETY PROP IN POSITION. SEE FIGURE 1

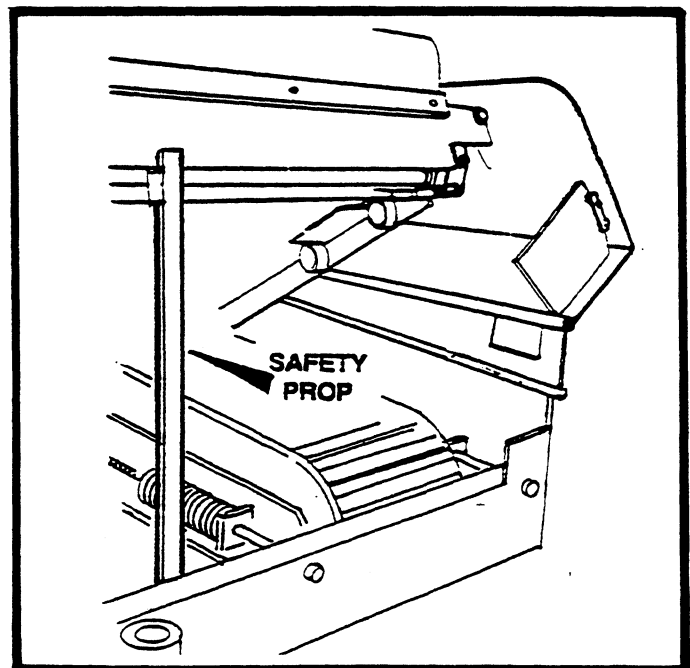
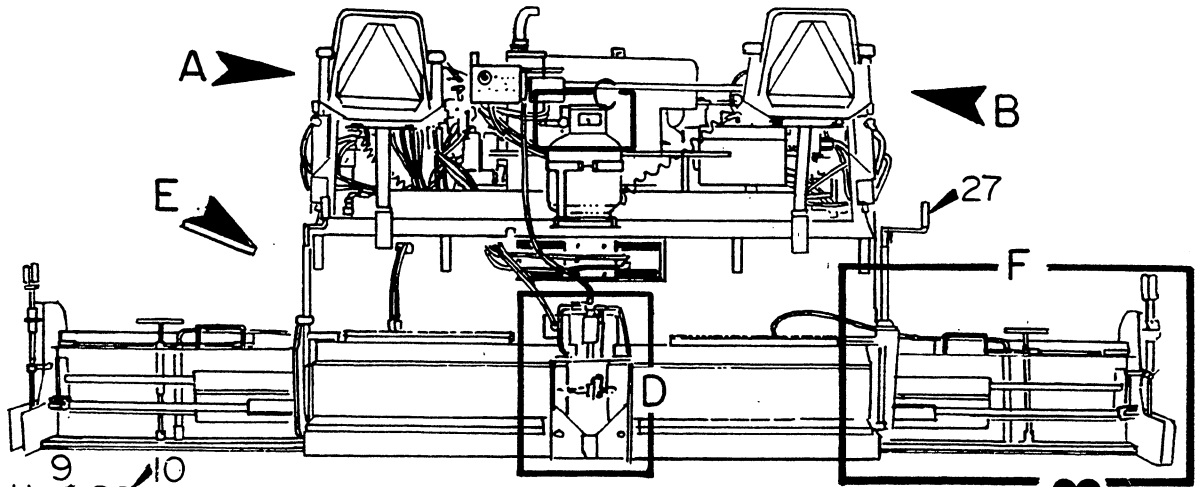
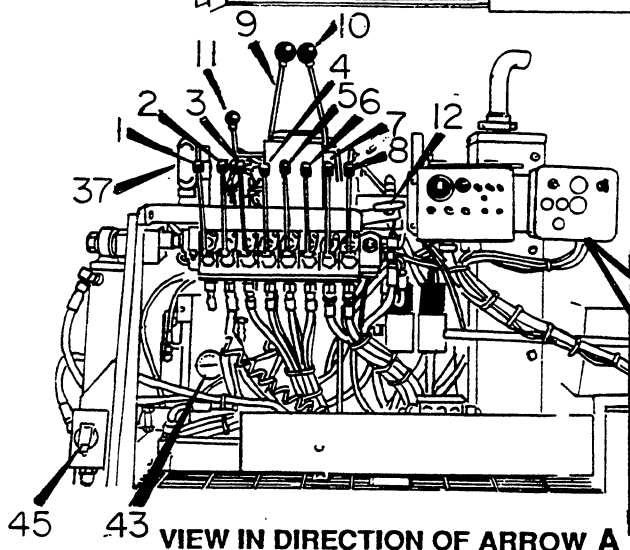

FIGURE 1



7000



VIEW IN DIRECTION OF ARROW A

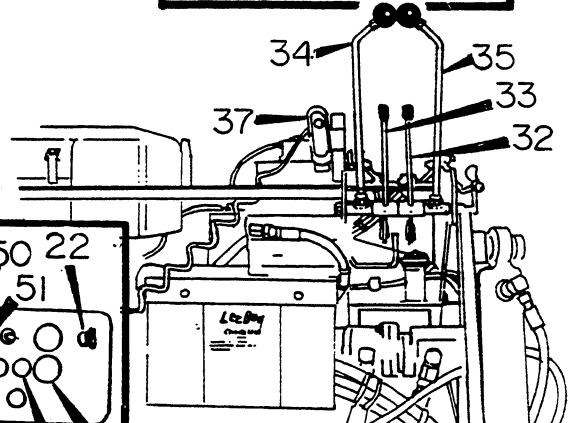
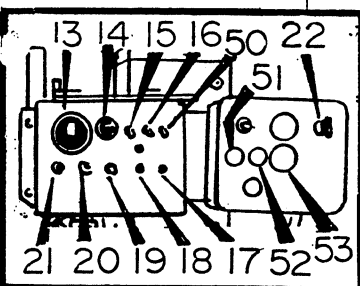

VIEW IN DIRECTION OF ARROW B

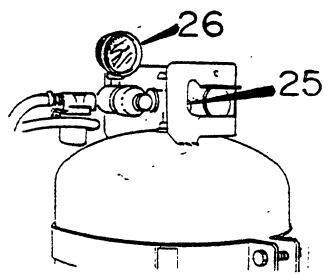

VIEW IN BOX C

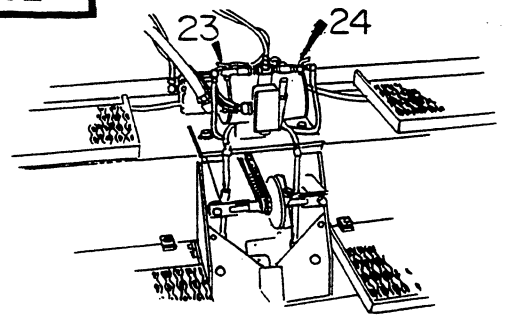

VIEW IN BOX D

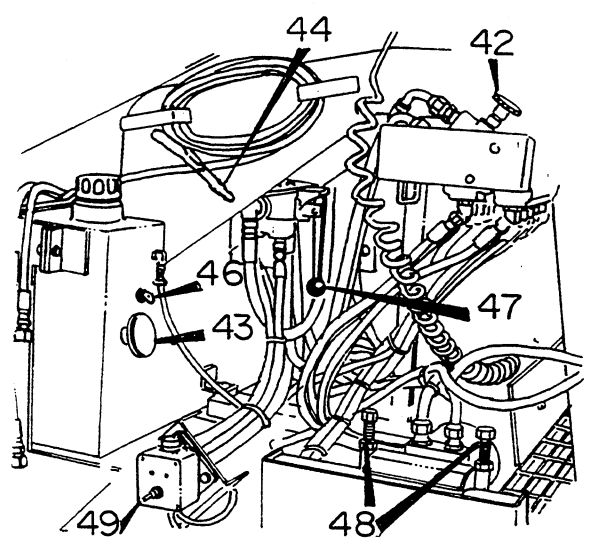

VIEW IN DIRECTION OF ARROW E

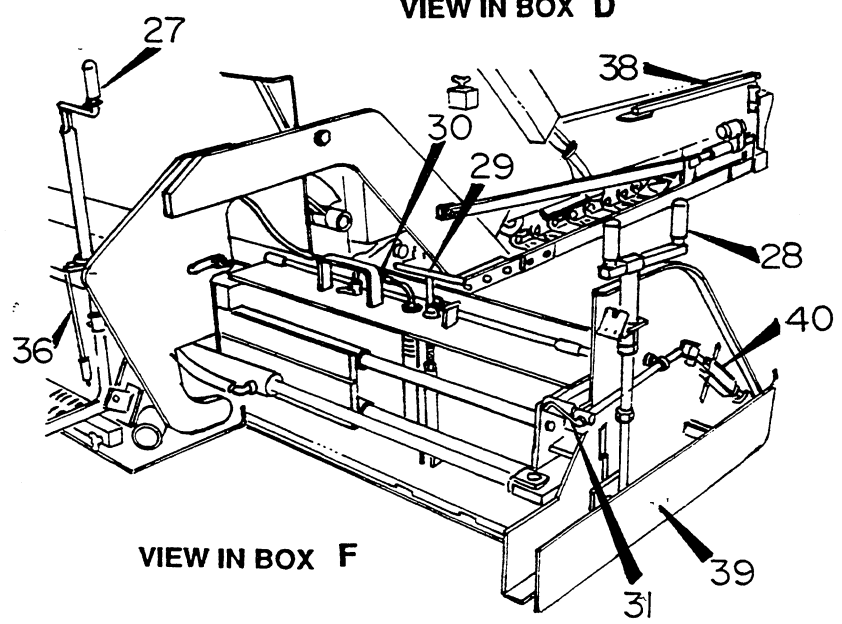

VIEW IN BOX F

CONTROLS AND DESCRIPTIONS

ITEM	CONTROL	DESCRIPTION
1	Screed extension, left	extends and retracts left screed extension
2	Screed extension, right	extends and retracts right screed extension
3	Screed lift	raises and lowers screed
4	Cut off, left	stops asphalt flow under left auger
5	Cut off, right	stops asphalt flow under right auger
6	Side wings	extends and contracts side wings
7	Auger, left	distributes asphalt to left screed extension
8	Auger, right	distributes asphalt to right screed extension
9	Drive, left	forward and rearward drive of left track
10	Drive, right	forward and rearward drive of right track
11	Lock, neutral position	locks forward/rearward levers in neutral
12	Throttle	Controls engine speed
13	Hourmeter	indicates hours on machine
14	Pre-heat burner	heats glow plugs for burners
15	Burner toggle	turns gas on to burners
16	Left auger switch	use for automatic auger
17	2 speed switch	shift paver to high range
18	Light (high range)	indicates high range, when on
19	Spraydown Pump	turns pump on
20	Right conveyor switch	starts right conveyor
21	Left conveyor switch	starts left conveyor
22	Ignition	to start engine
23	Left burner	controls flow of propane to left screed burner
24	Right burner	controls flow of propane to right screed burner
25	Propane tank main valve	opens and closes propane line pressure
26	Propane tank pressure regulator	regulates propane pressure
27	Thickness control lever	control of material depth
28	End gate control handle	sets end gate to desire depth
29	Thickness screw extension	adjust screed for seams
30	Burner extension valve	extension burner
31	Tilt control handle (joint matching shoe)	changes pitch of end gate
32	Lever, screed extension, right	extends and contracts screed, right
33	Lever, auger, right	distributes asphalt to right screed extension
34	Right side drive control, left	forward and rearward drive of left track
35	Right side drive control, right	forward and rearward drive of right track
36	Screed lever indicator	indicates position of screed
37	Screed depth remote switch	raises and lowers screed, varies asphalt thickness
38	Guide bar	alignment of paver to paving area
39	Joint matcher	helps even asphalt joint
40	Tumbuckle	adjust joint shoe
41	Bumper, roller (not shown)	used to push on asphalt truck tires
42	Valve, vibrator	helps compact asphalt
43	Gauge, temperature	provide hydraulic temperature
44	Spray, nozzle	used to spray and clean asphalt from paver
45	Outlet (Right not shown)	left auger paddle
46	Height oil lever	determines high oil lever
47	Raise conveyor valve	raise conveyor bed
48	Conveyor drive chain adjustment	adjust tension conveyor chain
49	Switch box	activate automatic grade component
50	Right auger switch	use for automatic augers
51	Light	indicates low oil pressure
52	Light	indicates dirty air cleaner
53	Light	indicates discharging through alternator

STARTING THE ENGINE

PRELIMINARY

Before you start the engine:

- A. Check fuel level and check lines and tank for leaks.
- B. Check crankcase oil level.

! CAUTION !

FAILURE TO MAINTAIN CORRECT OIL LEVEL IS GREATEST SINGLE CAUSE OF ENGINE FAILURES.

- C. Check hydraulic oil level. Oil level is determined by petcock on hydraulic oil tank.
- D. Make sure steering control levers are in the neutral position. To start, the safety latch lever must be in the latch position.
- E. Refer to engine operators manual for instructions when starting engine for first time. Follow engine manufacturer's recommendations for fuel and oil.

ENGINE/START-UP

The forward/reverse levers have a safety latch lever that needs to be latched in position before it will be possible to start engine. See figure 2.

1. Open throttle full.
2. Position drive levers to neutral. Put safety latch lever in latch position.
3. Insert key and turn clockwise to start position.
4. When engine starts and is running smooth, throttle back to idle. Allow engine to warm up for several minutes before moving paver. The warm up will give the hydraulic oil time to warm, providing for more efficient operation. In cold weather let hydraulic oil warm to 50° or 60° before moving.

NOTE

For your convenience, there is an extra key inside the switch box in case the original key is lost.

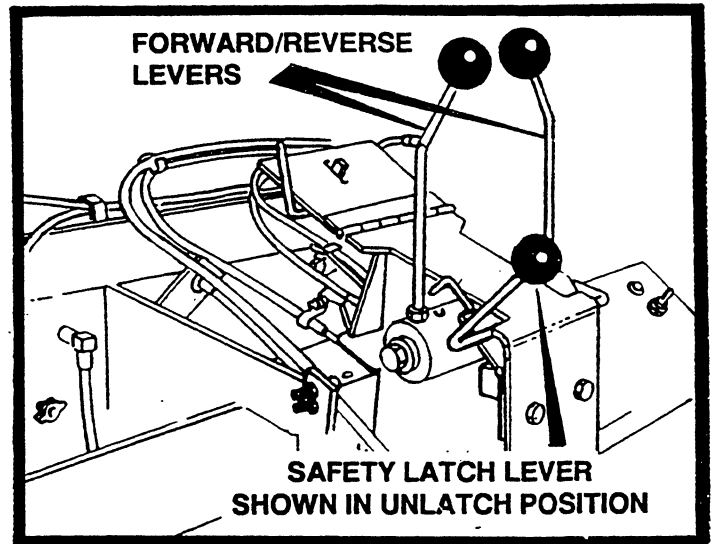

FIGURE 2

NOTE

The use of starting additives, such as ether, is not recommended.

STOPPING THE ENGINE

DIESEL ENGINE

1. Throttle engine down.
2. Turn ignition key counter-clockwise (CCW) to the "off" Position and remove.
3. If for any reason the engine does not shut down when key is turned to "off", take pin out of clevis on throttle, back of engine and push throttle control off.

! CAUTION !

DO NOT OPERATE THE STARTER LONGER THAN 30 SECONDS. IF THE ENGINE DOES NOT START, ALLOW THE STARTER TO COOL 2-3 MINUTES BEFORE TRYING AGAIN.

PAVER DRIVING INSTRUCTIONS

GENERAL

The forward/reverse plus turning will require exact movement. The steering levers along with the interconnected hydraulic components make possible the positive control necessary. The following procedures, plus illustrations in figures 3, 4 and 5, will provide a working knowledge of operating the paver through forward/rearward and turning requirements.

1. After the paver has been started and the motor is warmed up, paver movements may be made.
2. To drive the paver forward, push the steering levers together from the neutral position forward, likewise to drive to the rear, pull the steering levers toward the rear from the neutral position. Refer to figure 3.

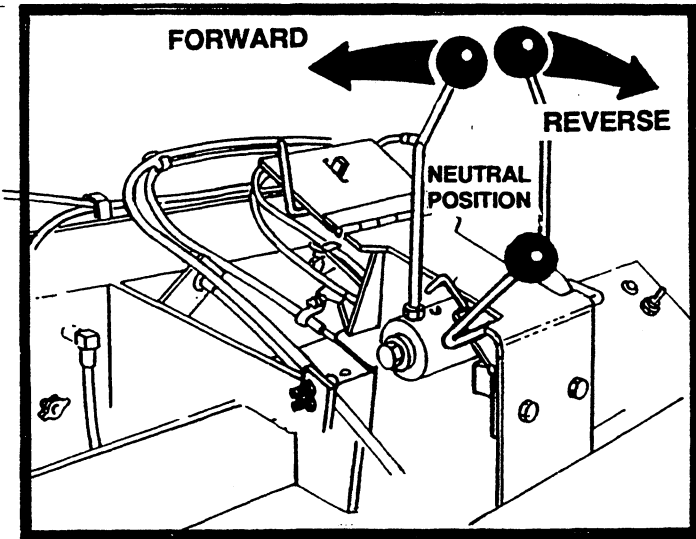

FIGURE 3

3. Depending on the direction of travel, turning the paver can be accomplished by pushing or pulling the steering lever on the inside of the turn toward the neutral position. Refer to figure 4.

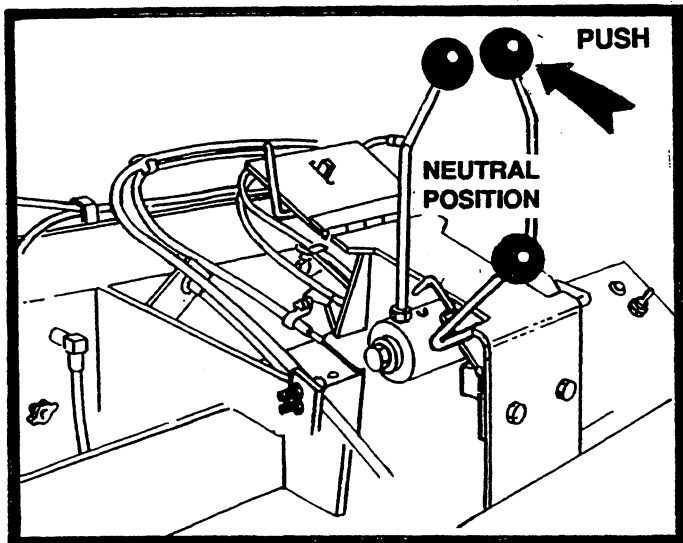

FIGURE 4

4. The traveling speed of the paver can vary greatly, by pushing or pulling the forward/reverse levers from neutral to the full forward or reverse position.

5. When making forward/rearward or turns, always make these moves slowly. Move the steering levers slowly and smoothly in the direction of intended travel.
6. When stopping, move both steering levers to the neutral position. See figure 5.
7. When paving, a constant speed is necessary to lay an even asphalt mat. Use the speed lock control to hold and retain steering levers in a fixed position. See figure 5.
8. To make a counter rotation movement, the steering levers are moved in opposite directions.

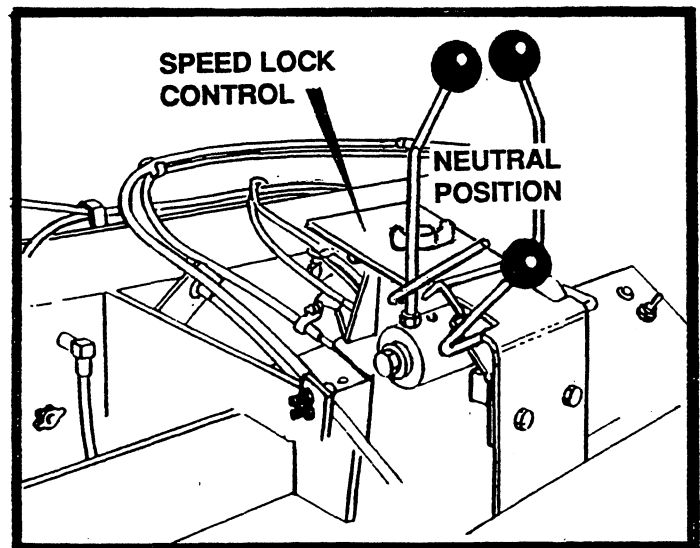

FIGURE 5

TRUCK HITCH ATTACHMENT (OPTIONAL)

GENERAL

The truck hitch is an optional attachment to several "Lee-Boy" pavers. It was designed to improve the asphalt laying process. This is mainly accomplished by keeping the truck driver off his brakes, preventing excessive and uneven braking. See operating instruction below.

1. To connect truck hitch to rear of asphalt truck, extend the arm extensions of the truck hitch by pulling on arm extension lever. See figure 6.
2. Drive paver slowly toward rear of truck until roll on hitch makes contact with rear tires of truck.

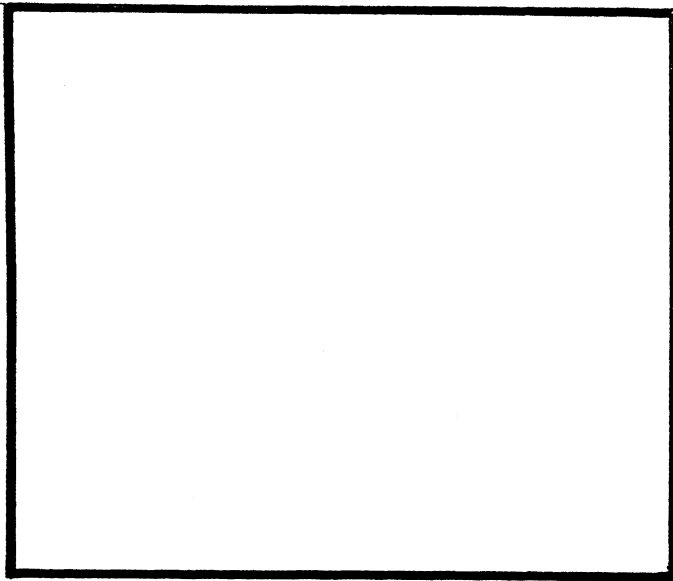

FIGURE 6

3. Retract the arm extensions until both guide rollers are fully locked into truck wheel rims.
4. May be necessary to adjust the roller guides to the inside of the wheel rims, initially. See figure 7.

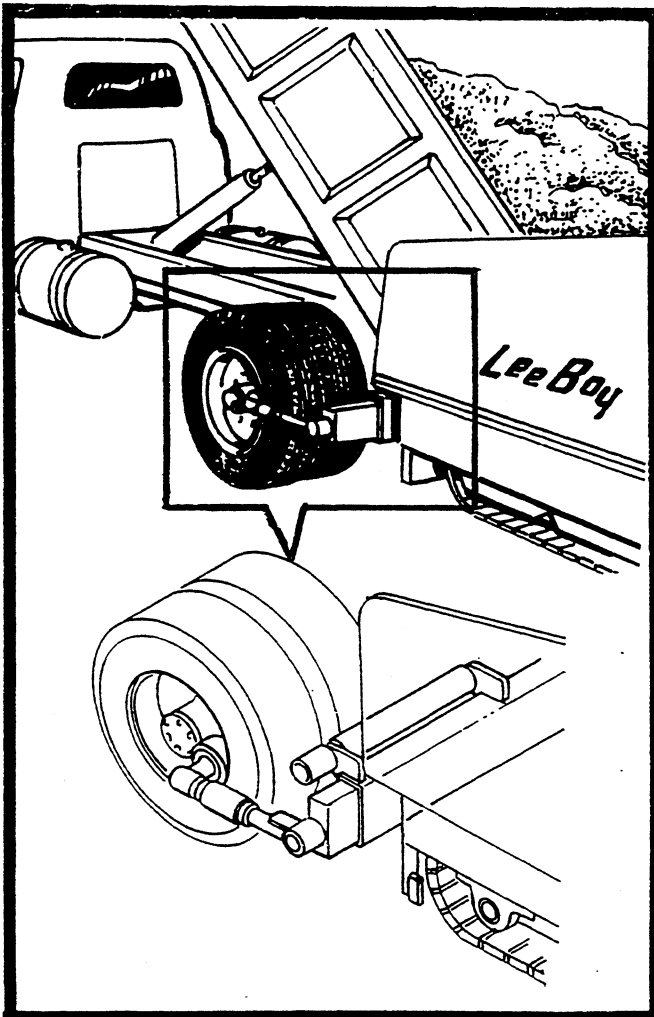

FIGURE 7

PAVING PREPARATION INSTRUCTIONS

BURNER IGNITION PROCEDURES:

GENERAL

The heating of the screed will require extreme care. The propane gas used to heat the screed is a volatile combustible that if treated with respect will not present a problem. Follow the procedures below and refer to the illustration figure 8 as required.

1. Make sure extension burners are turned off.
2. Fill propane bottle.

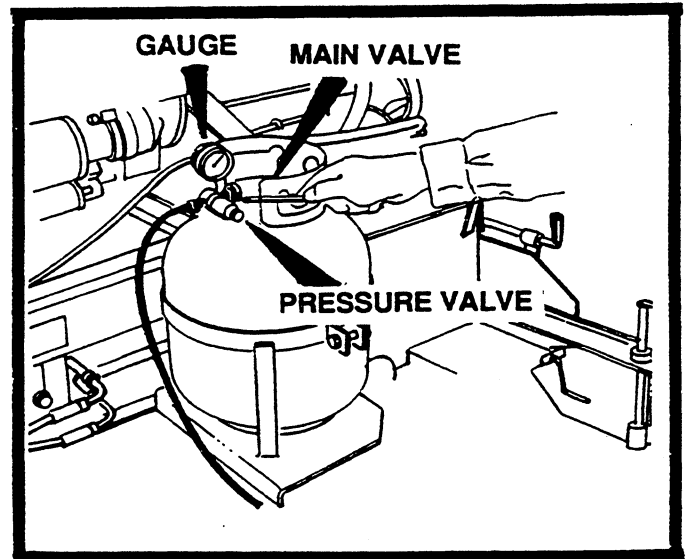

FIGURE 8

3. Set regulator at 15 lbs.
4. Turn main burner valve on.
5. Start engine and set throttle to about 1/4 R.P.M.

IF BURNERS DON'T IGNITE:

If burners don't ignite after repeating the procedures above, follow these procedures below.

1. Turn main burner valves off. See figure 11.

! CAUTION !

NEVER OPEN A VALVE TO BURNER UNLESS FLAME IS PRESENT. A BUILD UP OF UNBURNED GAS COULD RESULT IN A GAS EXPLOSION!

2. Flip burner toggle to the on position. This allows flow of propane to the valves. See figure 10.
3. Use extension burner to light main burners manually. Hold extension burner at end of main burner and turn valve on. Repeat this procedure for opposite side. See figure 9 .
4. Extension burners are lit manually by removing from quick coupling connector. Turn valve on extension burner and use lighter to light. Place burner back into holding socket and repeat this process for opposite side. See figure 12.
5. After screed has heated for about 10 minutes, turn the burners off. Do this by turning burner toggle on dash to off position. See figure 10.

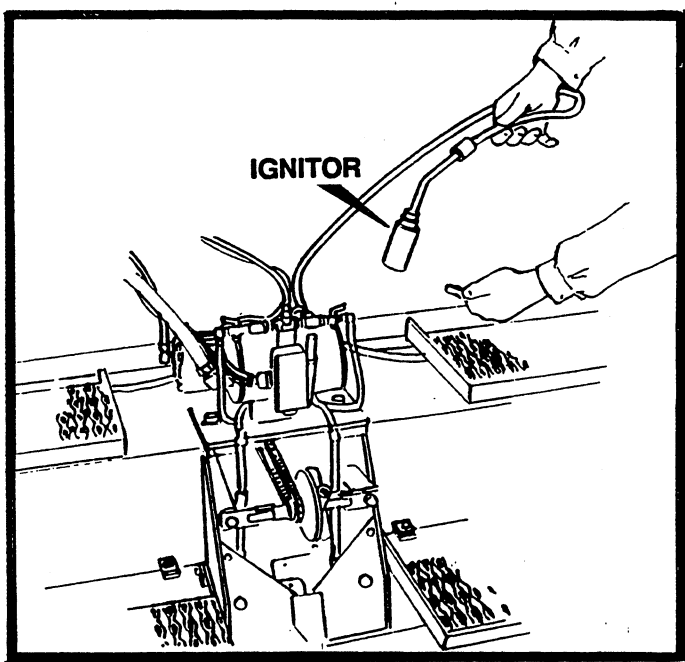

FIGURE 9

NOTE

Heating the screed helps prevent hot mix from sticking to the cold screed plate and produces a smooth, tight mat surface. Heating should not only be performed at the beginning of the job, but also if the machine is idle for a long time between loads (allowing screed plate to cool).

NOTE

If paving on a cool windy day it may be necessary to maintain low heat on the screed. To accomplish this, reduce the pressure on the propane tank from 6 - 8 pounds to 2 pounds. This will provide a low even heat that will not harm the screed. Do not attempt to regulate the burner with the burner valve.

! CAUTION !

IF FLAME COMES FROM END OF SCREED, SLOWLY TURN PETCOCK TO OFF. ALLOW FLAME TO GO OUT AND TURN PETCOCK BACK ON FULL.

! CAUTION !

TOO MUCH HEAT FOR TOO LONG CAN WARP SCREED PLATE AND CAUSE MAT TEXTURE PROBLEMS. WARP SCREED SHOULD BE REPLACED.

MANUAL LIGHTING OF BURNERS

The process for lighting the burners manually is not difficult. The following procedure will provide the necessary steps in lighting the burners. It is important to remember that propane is a voluble gas and for this reason safety should be a major consideration.

CAUTION! CAUTION! CAUTION!

1. Turn off all burner valves. See Figure 11.
2. Turn main propane valve on and set regulator at 15 lbs. Refer to figure 8.
3. Ignite burner with striker or lighter. See figure 9.
4. Hold ignitor burner at end of main burner. To light main burner turn burner valve on. See figure 11. (NEVER TURN BURNER VALVE ON UNLESS FLAME IS PRESENT.)
5. Repeat procedure in step 4 for opposite side.
6. The extension burners are held in position to the screed with a quick coupling connection. Remove the extension burner from quick coupling connector and light. See figure 12.

7. Replace extension burner back into hole and on to quick coupling connector.

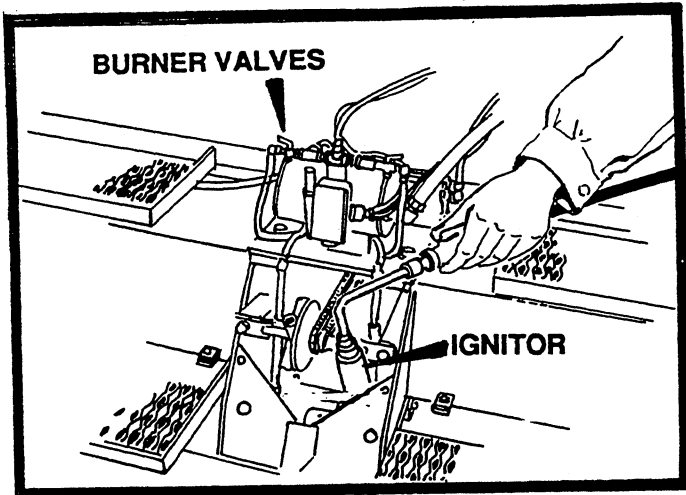

FIGURE 11

2. When lowering feeder, do not lower under pressure. Let the feeder down with engine shut off.
3. Do not let the paver set running with feeder on automatic any length of time. This may cause the hydraulic oil to over heat.
4. Spray the feeder drive chains periodically several times a day with diesel fuel.
5. When feeders are running and cutoffs are shut, there will be spillage the full width of the paver. This is normal and to help prevent this spillage, work feeders manually, when loading hopper and not paving.
6. Irregular movement of the feeder conveyor indicates that a problem may exist with the feeder chain. To eliminate this problem an adjustment to the feeder chain may be necessary. Refer to page 28 under FEEDER FLIGHT CHAIN ADJUSTMENT, procedure no. 3.

! CAUTION !

NEVER RAISE FEEDER WITH ASPHALT IN THE HOPPER.

! DANGER !

NEVER WORK UNDER FEEDER WITH OUT MAKING SURE THAT FEEDER IS BEING SUPPORTED BY SAFETY PROP AND THAT ALL UNAUTHORIZED PERSONNEL ARE CLEAR OF THE AREA.

! CAUTION !

NEVER OVER HEAT SCREED. ABOUT 10 MINUTES BEFORE STARTING TO PAVE IS ENOUGH TIME FOR PREHEAT. ON COOL DAYS TURN PROPANE REGULATOR DOWN TO 2 LBS. THIS SHOULD PREVENT SCREED FROM WARPING.

! CAUTION !

NEVER LET PAVER SET WHILE CONVEYORS ARE TURNING. IT IS POSSIBLE, IF PAVER SETS LONG ENOUGH, ASPHALT FROM CONVEYORS CAN FILL TRACKS AND CAUSE FAILURE TO THE BEARINGS OR IDLER.

! CAUTION !

TO PREVENT FLIGHT CHAINS FROM STICKING INSIDE OF CONVEYOR PANS, LUBRICATE THEM SUFFICIENTLY AT THE END OF THE DAY.

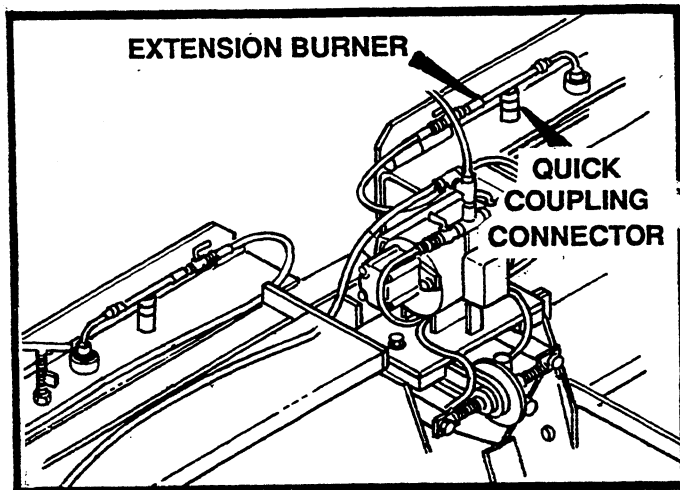

FIGURE 12

OPERATING FEEDER

GENERAL

The feeder is a very important part of the paver and for this reason close attention should be given on intergrading its operation into the total operation of the paver. Follow the procedure below.

1. Before raising or lowering feeders, fold sides in and out by hand. (The side rails have a double action motion causing the in and out movement.) Never use cylinder pressure to lower sides into place after lowering feeder. This may bend sides or break the chains on the sides.

OPERATION OF ELECTRIC FLIGHT SCREWS

GENERAL

The electric flight screw is an added convenience to the operator. A gauge is located on both sides of the paver. These gauges will provide the operator with quick reference to the height of the screed. Refer to figure 13 and follow procedures below.

1. Before paving, center the electric flight screws by referring to the screed elevation gauge on each side of the paver. Raise or lower until cable end is on '0'.
2. While paving, refer to both gauges and make minor adjustment to the screed by using the electric flight screws.

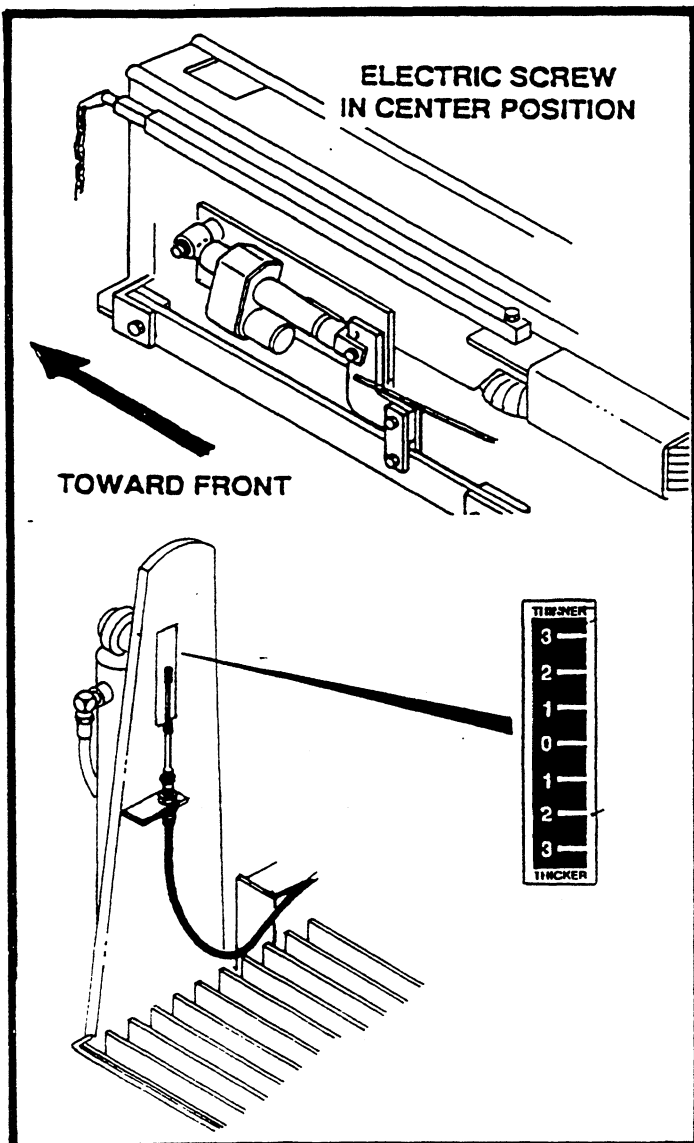

FIGURE 13

OPERATION OF HYDRAULIC CUTOFFS

GENERAL

The cutoffs are one of the most important functions of the paver, when used properly. Cutoffs are used primarily to control the flow of asphalt to the screed. Cutoffs can be used when making narrow passes, at the beginning and ending of each pass or pull. The cutoffs have been designed to break away if accidentally hits a man hole or ridge. This feature will prevent excessive damage to cutoff. (Tack underneath will break.)

1. Moving the hydraulic handle forward will increase asphalt flow to the screed. Pulling the handle back will decrease asphalt flow.

NOTE

Always work cutoff valve handle one at a time when opening or closing. If both handles are worked together, normally one will open or close before the other.

2. Always pull valve handles to close. If handle is allowed to return to center position on its own, it may pass center and cause cutoff to drift open once pressure is lost.

1. Unwrap the amount of hose needed and turn spray down switch on. Pull wand handle and spray.
2. After spraying turn off spray down switch and rewrap hose.
3. IMPORTANT: When using spraydown consider the environment and do not allow fuel oil to run onto the ground.

! CAUTION !

IF SPRAY DOWN PUMP IS NOT TURNED OFF AFTER EACH USE, THE PUMP WILL RUN OVER BY PASS AND AFTER A PERIOD OF TIME WILL BURN UP MOTOR.

AUTOMATIC AUGER

GENERAL

Automatic augers are used when laying mats wider than standard paving width. When used this will lessen the work load on the operator.

1. To install the paddle on the screed extension, extend the screed 6 inches and mount paddle on endgate as shown. Install the same way on left endgate. See figure 14A.
2. In order for the paddle to work, the electric cord leading from the paddle switch should be plugged into the receptacle box. A receptacle box is located on each side of the paver. After the electrical cords are plugged in, switch the two toggle switches on the dash to ON Automatic and pull the auger valve handles to engage augers.
3. IMPORTANT: After the paddle on screed extension has been mounted DO NOT RETRACT SCREED FULLY. DAMAGE WILL OCCUR.

! CAUTION !

WHEN USING AUGERS DO NOT TRY TO AUGER MATERIAL FROM ONE SIDE OF MACHINE TO THE OTHER SIDE. AUGER COVER IN CENTER BLOCKS THE FLOW. DAMAGE WILL RESULT IN BEARINGS AND COVER.

NOTE

When paving basic width of machine augers are not required to run.

ELECTRIC SPRAYDOWN

GENERAL

The spraydown on your machine is used to spray fuel oil on any part of the machine that comes in contact with the asphalt. Build-up of this material will cause damage to components. Spray the area often, the screed extension on top and bottom, augers and hoppers.

AUTOMATIC AUGERS: NEW STYLE (TIED IN WITH CONVEYORS)

Automatic augers are mostly used when paving 9' or 10' where augers are capable of running material over top of endgates, causing extra hand work.

! CAUTION !

**NEVER RUN AUGERS WHEN PAVING 8' WIDE.
NEVER RUN AUGERS IN REVERSE TO PUSH
MATERIAL FROM LEFT TO RIGHT OR RIGHT TO
LEFT.** Center chain guard prohibits material from crossing from one side to the other. (Damage will occur).

HOW TO OPERATE:

1. Pull auger control handles on valve to "on" for augers to feed extensions.
2. Turn left & right auger toggles on dash "on". Now the augers will come on and off with the conveyors.
3. When paving wider widths, and augers do not provide sufficient asphalt flow, refer to the following step that identifies to the corresponding machine.

LOADING AND UNLOADING

GENERAL

Trailers used to haul the paver should have ample capacity to carry the weight of the paver. Place the trailer in a clear, level area for loading or unloading.

Work slowly and carefully to avoid accidents. Keep the area clear.

UNLOADING

1. Remove tie down equipment.
2. Start and warm up engine.
3. Set throttle at 1/2 operating RPM. Shift transmission into low range. Set steering control levers so paver moves very slowly.
4. Make sure:
 - A. Screed position - UP
 - B. Extendable screed - IN
 - C. Gates below augers - CLOSED (Caution - Never back up with cutoff gates open.)
 - D. Speed range - LOW (Never shift Transmission on incline.)
5. Move the paver forward down the ramp as shown in figure 15.

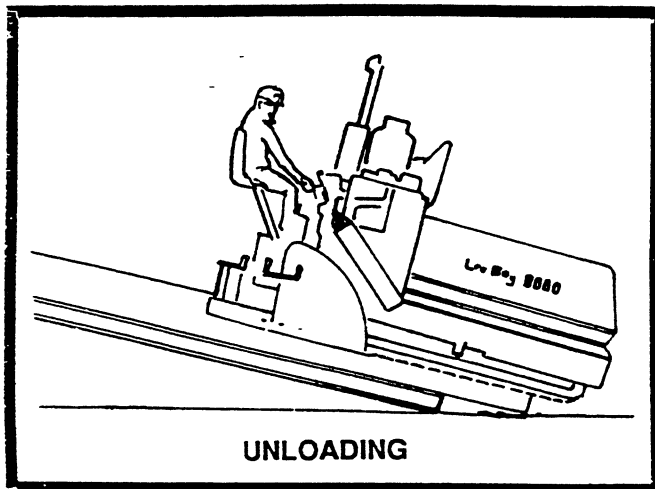

FIGURE 15

! DANGER !

MAKE SURE THE ENGINE IS RUNNING AT HIGH ENOUGH RPM'S TO PROVIDE THE HYDRAULIC PUMP WITH ENOUGH GALLONS PER MINUTE TO FUNCTION PROPERLY.

NOTE

A man should always be on the ground to assist the operator in the unloading function.

! CAUTION !

DO NOT LET THE SCREED STRIKE THE RAMP WHEN MOVING OFF THE RAMP. THIS CAN BREAK THE BEARINGS ON THE THICKNESS CONTROL SCREWS OR WELDS ON THE LEVELING ARMS. A LONGER RAMP OR BLOCKS MAY BE NECESSARY TO REDUCE THE ANGLE OF UNLOADING.

NOTE

If you have a problem unloading the paver, - STOP — LOOK — THINK !

LOADING

1. Move paver to base of ramp. Line up tracks with the ramp. Load paver screed end first. Set throttle at 1/2 operating RPM and steering control levers so paver moves very slowly onto the ramp.
2. Make sure:
 - A. Screed position is - UP
 - B. Extendable screed - IN
 - C. Gates below auger - CLOSED
 - D. Speed range - low (Never shift transmissions on grade).
3. With the steering control levers slowly guide the paver up the ramp. If the paver is loaded hopper first, the weight of the operator on the walkway will tend to tip the paver onto the screed. See figure 16.
4. When the paver has reached the desired position and is centered on the transport trailer, stop the unit.
5. Lower screed to deck.
6. Shut down engine.
7. Secure paver to transport as directed by regulations.
8. Always have a helper on the ground who can assist the operator in moving the paver onto the transport.

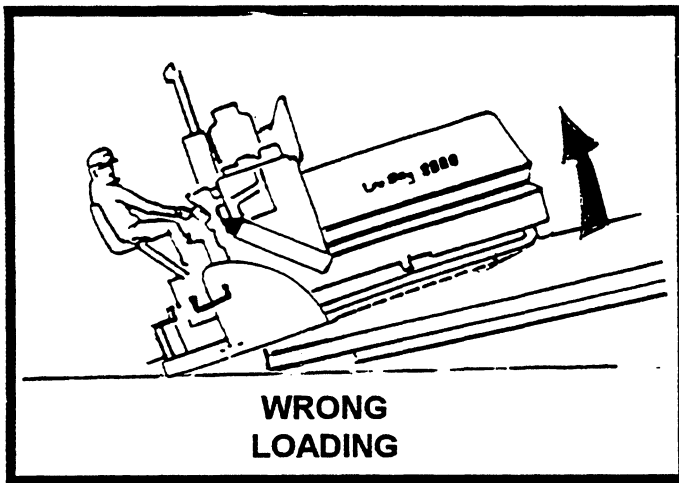

FIGURE 16

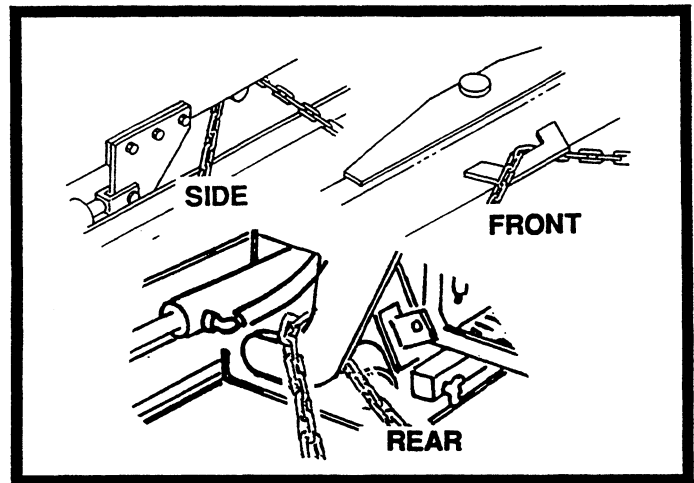

FIGURE 18

TIE DOWN PROCEDURE

1. Position paver on trailer centered from side to side. See figure 17.
2. Attach tie down chain to the hopper end of paver at the center hook provided.
3. Refer to figure 18, three tie down points are shown. Because of the varying characteristics of the truck bed or trailer bed in use, it is not practical to describe the correct method to chain the paver down. In all cases the front tie point should be used. Depending on the truck or trailer used, at least one of the other tie points should also be used.

! CAUTION !

TO PREVENT AN EXCESSIVE JOLT TO THE UNDERCARRIAGE AND THROUGHOUT THE PAVER, REDUCE TRAVELING SPEEDS TO A MINIMUM BEFORE THE PAVER TRACKS COME IN CONTACT WITH LOADING RAMPS OR AN ABRUPT CHANGE IN THE SURFACE. IF ENCOUNTERED, THE TRACK DRIVE SPROCKET OR POSSIBLY OTHER COMPONENTS MAY BE DAMAGED BECAUSE OF THE EXCESSIVE JOLT.

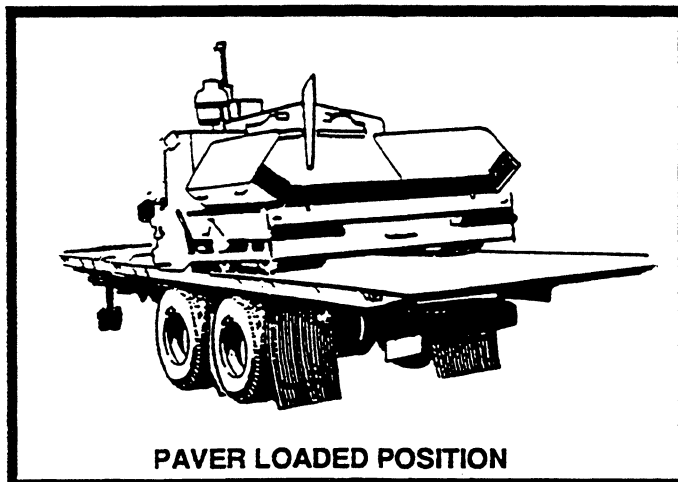

FIGURE 17

4. Place chocks at wheels or tracks.
5. Make sure all chains are tight before moving.

PAVER PREPARATION INSTRUCTIONS

To prevent costly downtime, the paver should be checked thoroughly before each use. Use the list below to assist in checking the paver.

1. Check engine oil (see engine manual), hydraulic oil, gear box oil and diesel fuel.
2. Refer to Lubrication Chart on page 25 and lubricate as specified. (Some area or weather conditions may require extra lubrication).
3. Check hydraulic hoses, fittings, pumps and motors for leaks, excessive wear or damage.
4. Check the engine safety switch: (the engine should only start when forward/reverse levers are in the neutral position.) See figure 2.
5. Check all electrical functions before distributing asphalt.
6. Spray fuel oil on any part of the paver that comes in contact with asphalt.
7. Check burner ignition.

STARTING TO PAVE

GENERAL

The paver is capable of placing bituminous base, binder and surface courses, lime or portland cement stabilized sub-base and graded aggregate materials up to a thickness of 6 inches. The paver has a production rate of 250 tons per hour.

Equipped with electric and manual thickness controls and a 8' to 13' wide screed, the paver can handle everything from driveways and small parking lots to large parking areas and secondary roads.

Before starting to pave, keep the following points in mind:

- A. Plan the project so that the narrowest passes are first, (the basic width of the paver) leaving the widest pass until last.
- B. Make sure to use a reference guideline. This can be a curb, gutter, adjacent mat or a string line. It is important that the first pass be straight as it will be the guideline for the following passes. Use the guidebar gauges as shown in Figure 19.
- C. Never run the paver through a pile of mix that has been dumped in front of the machine. Not only will this affect the level of the mat being laid but damage may result.

NOTE

If paving on cool windy days, it may be necessary to maintain low heat on the screed. To accomplish this, reduce the pressure on the propane tank from 6 - 8 pounds to 2 pounds. This will provide a low even heat that will not harm the screed. Do not attempt to regulate the burner with the burner valve.

! WARNING !

NEVER SPRAY DOWN PAVER WITH FUEL OIL WHILE BURNERS ARE LIT. A FIRE COULD CAUSE SERIOUS BURNS OR DEATH!

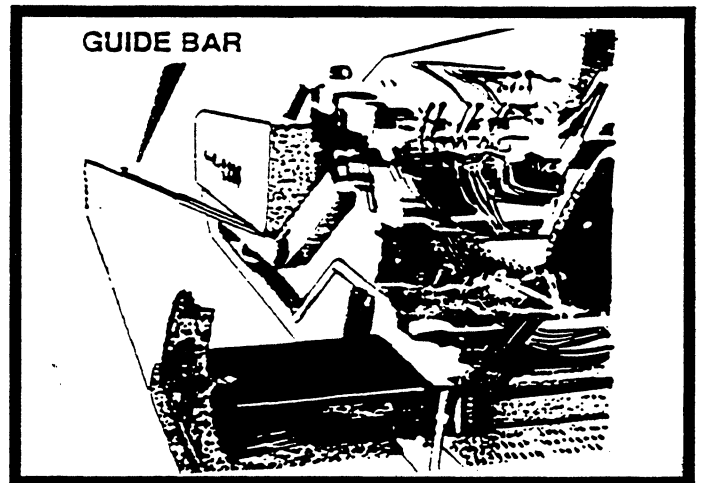

FIGURE 19

- D. It is the operator's job to guide the truck up to the paver and signal the driver when and how much to dump into the hopper. Truck drivers must maintain a light pressure on his brakes to keep truck from dumping material on the roadway. See figure 20. If your paver is equipped with a truck hitch, the truck driver will not be required to maintain pressure on the brake. See page 10, figure 7.
- E. Always pave in Low range.
- F. If paver is equipped with a truck hitch, refer to Truck Hitch Attachment instruction on page 10.

! DANGER !

BEFORE STARTING FORWARD WITH PAVER MAKE SURE NO ONE IS IN FRONT OF IT.

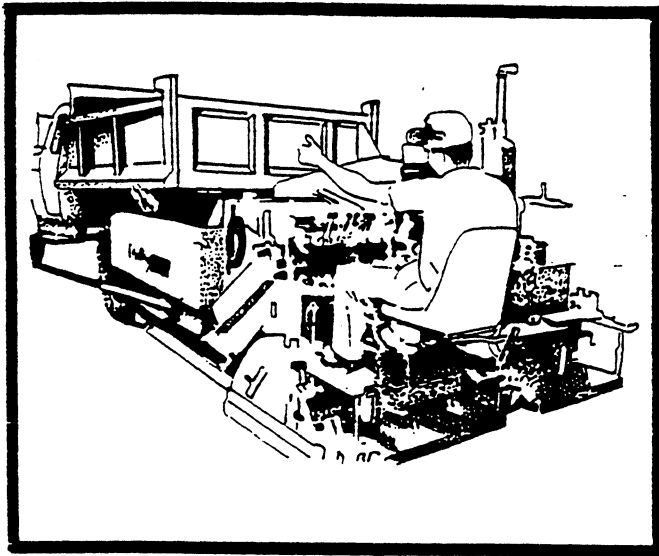

FIGURE 20

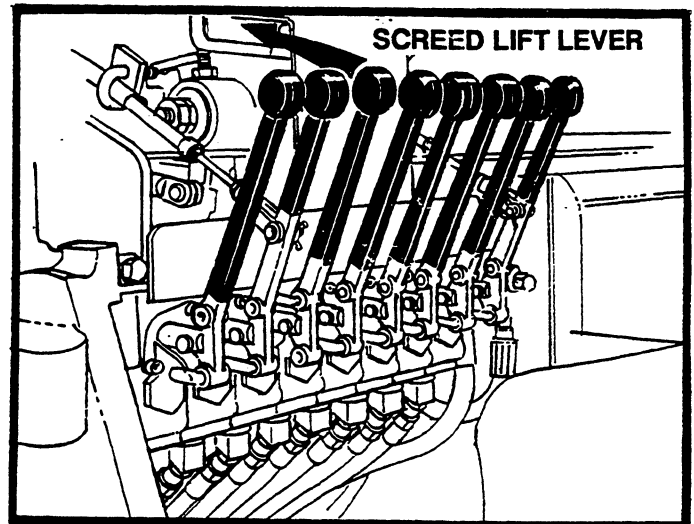

FIGURE 21

SETTING SCREED TO PAVE

The following procedure will assist in getting the screed ready to lay the desired mat whether positive, zero or negative crown. See figure 25.

1. Move to the starting position.
2. Extend the screed to the desired width.
3. To get depth, set screed on starter blocks. See figure 22.
4. Level screed with flight screws until neutral position is felt. (Neutral position is when the pressure on the flight screw is same when screwing either clockwise or counter clockwise.)
5. Push screed valve lever all the way forward into float position. This will take the hydraulic pressure from the cylinder, allowing screed to float. See figure 21.
6. Turn flight screw about one complete turn clockwise.
7. The gauge shown is used to either increase or decrease thickness of mat in small amounts. This gauge, after following procedures 1 through 6, should be at zero or very close to zero (0). See figure 13.
8. To obtain the crown or valley desired refer to figure 23, and loosen hex head nut. Remove crown handle and depending on the requirement push down for positive crown or pull up for negative valley.
9. There is a gauge located on rear of crown adjuster to indicate when screed is level. See figure 23.

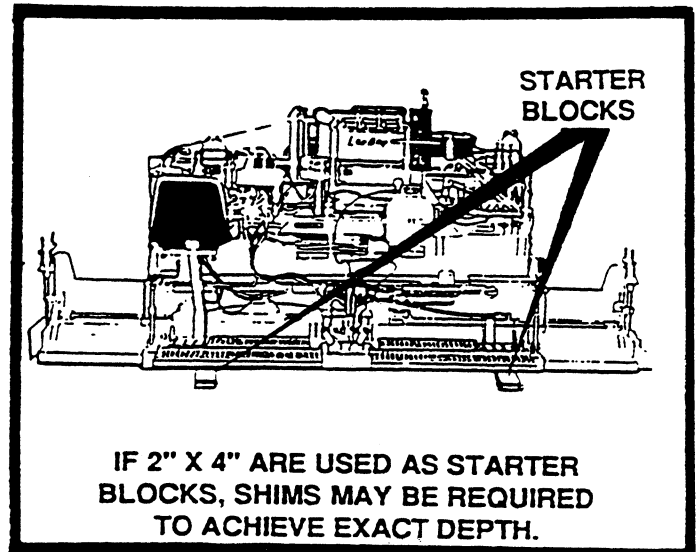

FIGURE 22

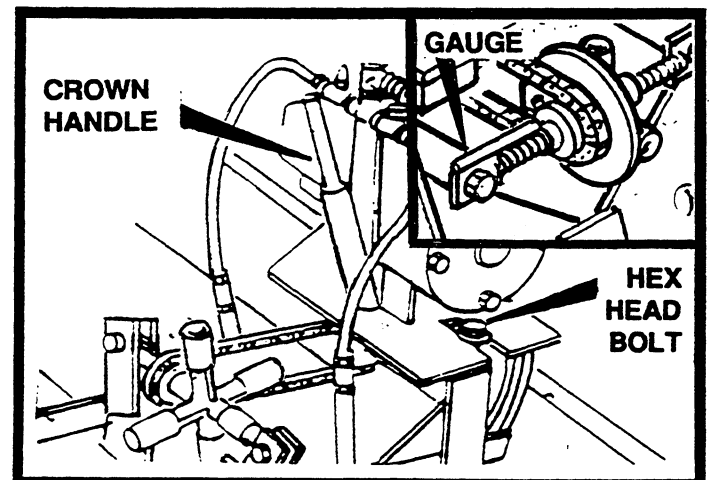

FIGURE 23

10. Set crown control. The screed plate is a one-piece unit which is actually bent to provide the required crown setting. See figures 24 and 25.

12. Tighten hex head nut on vibrator securely before paving.

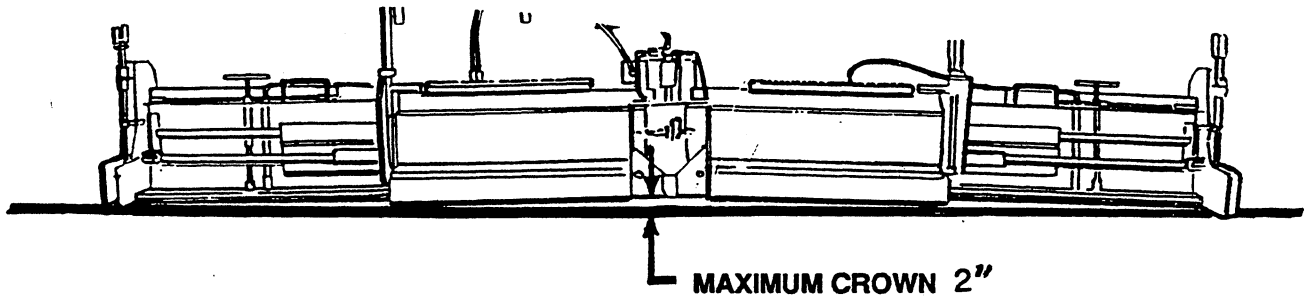

FIGURE 24

11. To get exact crown or valley, measure the distance between a flat level surface to the center bottom portion of screed. See figure 24. Make adjustments with crown and valley control.

Crown may be placed in the leading edge and/or the trailing edge of the screed plate. Crown in the leading edge aids material flow under the screed plate, only. Trailing edge crown puts a crown in the mat. As an example; trailing edge crown is 0, leading edge crown is 1/8". With this set-up there will not be any crown placed in the mat laid by the paver, however, material flow under the screed plate will be improved. Trailing edge crown is set at 0 when shipped from the factory. The chain connecting the leading and trailing edge crown control assures that the relationship of the edges remains constant as the trailing edge is changed to meet job conditions.

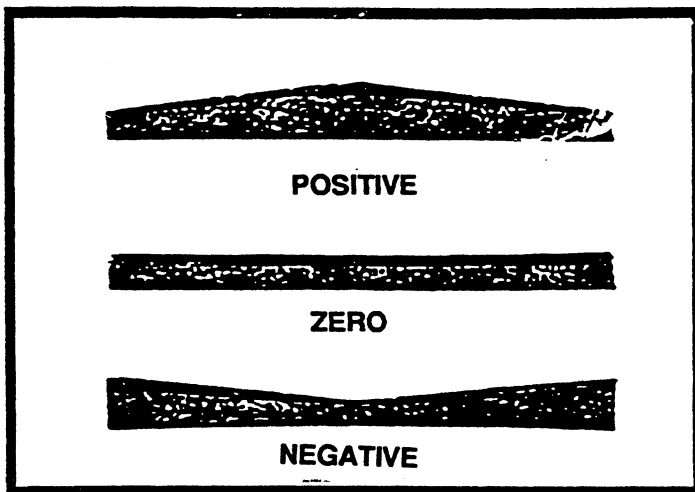

FIGURE 25

NOTE

Positive crown is when the middle of the mat is raised to permit water to drain to each side.

Negative crown is the lowering of the center of the screed plate. Negative crown might be used in an alley where drainage down the center of the alley is necessary.

SETTING SCREED ENDGATES

1. On first pass unlock depth screws and lower endgate to about 1/4" off desired depth. This should provide a nice square edge. See figure 26.
2. The scale located on each endgate will show proper setting or depth.
3. Tilt adjusters on endgate are to be set so front of endgate tilts down slightly when screed is lifted.
4. This will allow the endgate to set itself to grade.

NOTE: When paving never let end gate carry the weight of the screed. This will cause screed compaction to vary and slickness.

5. During operation if endgates start to dig in at front, adjust the tilt so the endgate tilts back.

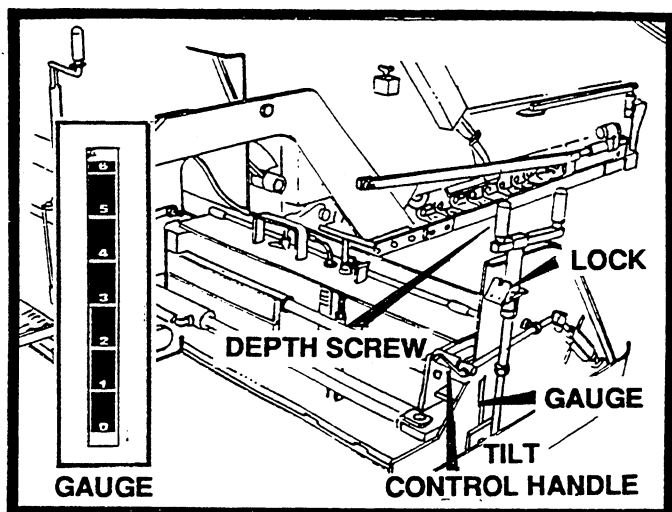

FIGURE 26

- When making a joint, endgate must set to '0' on scale or where it fits flush with bottom of screed.

NOTE: When making a joint, spray fuel oil on runner and jointer shoe.

- On first pass leave about 6 to 8 inches of unrolled asphalt where joint is being made. By doing this the joint shoe can be placed in position by using turnbuckle on endgate to hold it in place.
- In laying a joint, if the joint looks too high or too low, adjust main flight screw on screed about one (1) round at a time and allow 4 to 5 ft. of travel to correct itself. (Too much adjustment up or down may cause a roller coaster effect.)
- If making a cold joint, set endgate down about 1/4", this will give a nice even edge.

SETTING SCREED EXTENSIONS: (Used when paving over 8 feet)

The screed extensions should be heated before making adjustments with ratchet. (Ratchet shipped with machine, in tool box). When the adjustment is made the pressure on the rear edge of extended screed is the same as on the rear edge of main screed. The result of making this adjustment will be a smooth mat the length of the screed.

- Heat screed extension before making adjustment to extended width.

- Adjust tilt on rear edge of extension by turning T-handle counter-clockwise. This is done to give the same amount of compaction on extension and slickness as main screed.
- If drag occurs, then too much pressure is on the screed extension and the extension is carrying all the weight. Correct this by turning the T-handle clockwise until both the screed and the screed extension produce the same looking mat.

PAVER OPERATION:

- Follow start-up procedures. See Engine Start-Up, page 8.
- Position paver to start of mat. Adjust screed in accordance with Screed Leveling Instructions on pages 19 and 20.

NOTE: When material starts to discharge from under screed, the screed valve handle should be pushed forward into screed float position.

- Open hopper wings into working position. When first starting to pave allow only a partial load of asphalt to enter the hopper.

! CAUTION !

NEVER FOLD HOPPER WINGS FULLY IN WHEN HOPPER IS FULL OF ASPHALT.

- Switch toggle switches on to automatic conveyor and convey material back to screed. AUGERS ARE NOT NEEDED WHEN PAVING A BASIC 8 FOOT PULL.
- Open cut-off gates under auger and start paving. Move slowly at first so adjustments can be made to screed.

! CAUTION !

NEVER BACK UP WITH CUT-OFFS OPEN. CUT-OFFS ARE DESIGNED TO BREAK AWAY FROM CYLINDERS WHEN HITTING A MANHOLE OR OTHER HARD OBJECTS. THIS HAPPENS GOING FORWARD NOT IN REVERSE.

- To prevent excessive hand work, about 2 to 3 feet from end of pull, switch off conveyor toggles and shut cut-offs. Return paver back to starting position to begin next pull. Position and set screed end gate on joint side back to '0' or flush with bottom of main screed. Repeat process as done in first pull.

7. The paver can operate using one side only. Material from opposite side however, can not be augered to the working side. This is prevented by the auger center cover. It is possible to leave both cut-offs shut and open the end gates on screed. This method is generally used in doing pot holes and patching.

ROUTINE MAINTENANCE

GENERAL

Preventive maintenance on the Lee-Boy paver is a simple job that will provide years of trouble-free operation. Adjustments, also, are simple; they can be performed, in the field, with ordinary hand tools. Engine preventative maintenance, other than oil, air and fuel filter changes, is not covered in this section. Refer to engine operators manual for engine service information. (NOTE: For your convenience there is an oil drain hose located in the tool box.)

10 - HOUR OR DAILY ROUTINE MAINTENANCE

1. Cleaning the paver at the end of the working day while the machine is still hot is like putting money in the bank. A paver that is continuously left with mix stuffed in every corner is going to increase maintenance costs. Scrape off mix and spray fuel oil on the screed plate, hopper, etc., any place that has come in contact with the mix. Spray down the feeders while they are running. All cleaning should be performed while the machine is hot. (NOTE: For cold weather, keep conveyor flight chain properly oiled with fuel oil. This will prevent conveyor from sticking inside of conveyor pan. Neglect could result in conveyor bars bowing if conveyor does stick.)

! CAUTION !

IF MIX IS ALLOWED TO REMAIN IN THE MACHINE OVERNIGHT, POSSIBLE DAMAGE CAN RESULT ON START-UP THE NEXT DAY. POOR "HOUSE-KEEPING" WILL INCREASE MAINTENANCE COSTS.

2. Raise feeders (See Adjustments - To Raise Feeders) and clean mix off all flat surfaces. This operation is quick and simple when the paver is still hot. Immediately after raising feeders place the safety prop in position.

3. Fill fuel tank for engine and spray down system to keep condensation from forming.
4. Perform engine preventative maintenance as described in your engine operators manual. Any engine preventative maintenance should always begin with an oil check. Also, check oil level in oil bath air cleaner. (If Equipped.)

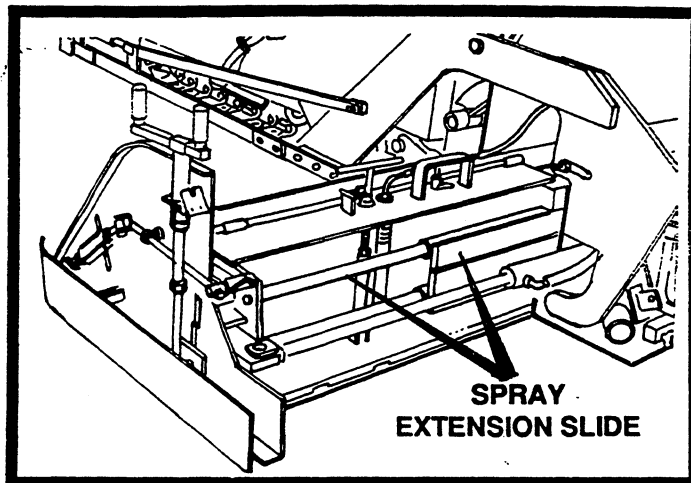

FIGURE 27

5. Spray thickness control screws with fuel oil to keep them working smoothly.
6. Grease extension slide with multi-purpose grease or spray with fuel oil at points shown in figure 27.

50 HOUR OR WEEKLY ROUTINE MAINTENANCE

1. Check hydraulic oil and add if necessary.

! CAUTION !

YOUR PAVER'S HYDRAULIC SYSTEM REQUIRES CLEAN, CONTAMINANT-FREE OIL. TAKE CARE WHEN WORKING WITH THE HYDRAULIC SYSTEM TO INSURE ITS COMPLETE CLEANLINESS. (TRACTOR "B" HYD.)

2. Check that battery electrolyte level is to the full indicator and add clean distilled water, if required. Use a battery hydrometer to measure specific gravity in each cell. A fully charged battery will read 1.265 specific gravity at 80 F. (27C.). At the same time check all battery connections and remove any corrosion that is present.

! DANGER !

DO NOT SMOKE WHEN OBSERVING BATTERY ELECTROLYTE LEVEL. THE FUMES CAN EXPLODE. ELECTROLYTE IS AN ACID WHICH CAN BURN IF IT CONTACTS SKIN OR EYES. IF CONTACT IS MADE, FLUSH AREA IMMEDIATELY WITH WATER.

3. Check air cleaner, if the engine is equipped with a dry type element. Improperly serviced air cleaners wear out engines—FAST! In just a few hours a small amount of dirt will wear out a set of piston rings! Refer to your engine's operators manual for service information. Also, perform any other engine preventative maintenance as described in the engine operators manual.

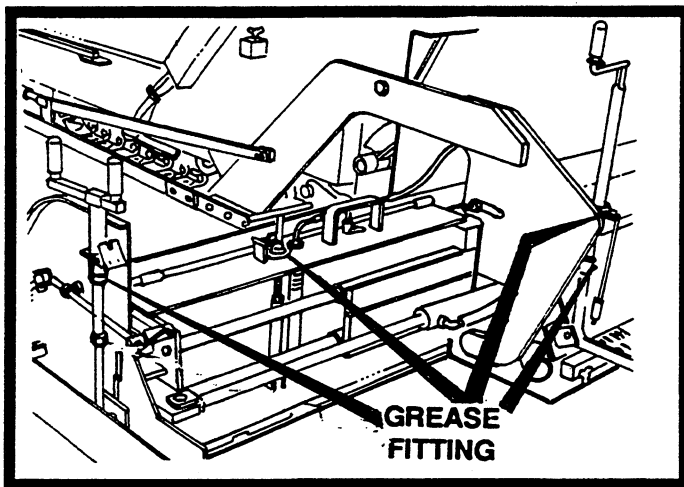

FIGURE 28

4. For both ends of the screed, grease the two grease fittings on the flight screw (the fitting on the depth screw and the fitting on the flange bearing) located on top of the extension screed. See figure 28.

100 HOUR OR MONTHLY ROUTINE MAINTENANCE

1. Check oil level in the torque hub by removing the plug at the 3 o'clock position. If oil comes out no oil is needed. Insert plug and tighten. If oil does not come out, remove the plug at the 12 o'clock position and fill torque hub with 90 wt. gear oil until oil starts to appear at the other hole. Replace both plugs and repeat process to other torque hub. See Figure 29.

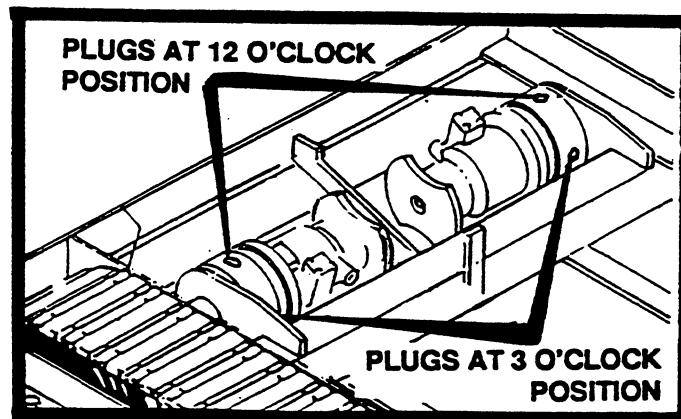

FIGURE 29

3. Replace dry type air filter, if equipped. Refer to your engine operators manual for service information.
4. Change engine oil. To assure complete removal of contaminants in the oil, perform the oil change while engine is warm.

After draining used oil, clean and reinstall drain plug and fill crankcase to the full mark with manufacturer's recommended oil. Change oil filter at every other oil change. (15 W 40 Motor Oil)

5. Change oil in oil bath air cleaner and rinse filter element in clean fuel to remove impurities. Also, perform any other engine preventative maintenance as described in the engine operators manual.

Check and adjust all chains, as required.

250 HOUR OR QUARTERLY ROUTINE MAINTENANCE

Perform the 250 hour preventative maintenance as described in the engine operators manual.

1. Change filter charge between valve and pump.

500 HOUR OR SEMI-ANNUAL ROUTINE MAINTENANCE

1. All bearings are sealed and have grease fittings. These should be greased with multi-purpose grease using a handgun. Be careful to avoid blowing the seals.
2. Perform the 500 hour preventative maintenance as described in the engine operators manual.

1000 HOUR OR ANNUAL ROUTINE MAINTENANCE

1. Drain and flush the hydraulic tanks. A drain plug is located on the bottom of each tank for this purpose. The recommended hydraulic oil is 0 - 210° Tractor Hyd. Tractor "B".
2. Perform the 1,000 hour preventative maintenance as described in the engine operators manual.
3. Anytime the paver has been repainted or the decals have been removed, damaged or can't be read, a new set of decals should be ordered and re-installed for safe operation.

NOTE

When performing any routine maintenance such as 50, 100, 250, 500 and 1000 hour, always include previous routine maintenance hours to the higher hourly schedule.

IMPORTANT NOTICE!!

The changing of oil and cleaning of the paver should only be done in a designated area that can contain the oil and chemicals involved in any maintenance requirement. These by products should be discarded in accordance with environmental regulations.

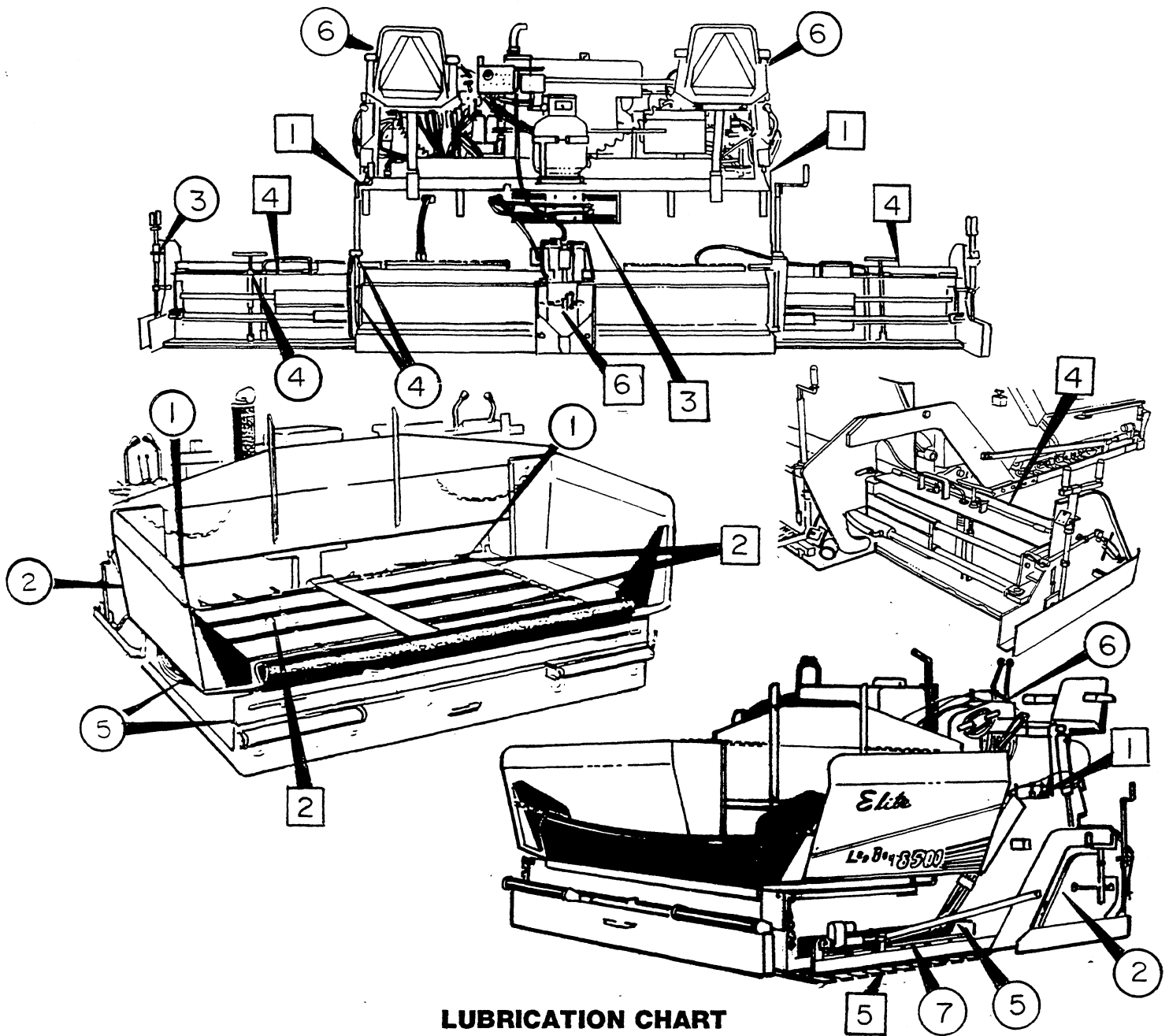

LUBRICATION CHART

Item No.	Description and Location	Interval
①	AUGER, each end of auger, (Best time at end of day)	Daily
②	FEEDER PIVOT, both sides, ahead of screed end (Must remove chain guard to grease)	Weekly
③	DEPTH SCREW, grease first in lock position, unlock turn 180° and grease	Weekly
④	FLANGE BEARING & FITTING on flight screw plus FLANGE BEARING on T-Handle of extension, both sides.	Weekly
⑤	PILLAR BEARINGS, axle	3 Months
⑥	DRIVE LEVEL, on pivot housing	Weekly
⑦	TRACK HOUSING, grease as specified on page 26.	A/R
①	FEEDER CHAIN, left and right sides	Daily
②	FEEDER AND AUGER, as shown	Daily
③	AUGER CHAIN, middle of paver	Daily
④	SCREED EXTENSIONS, left and right (clean surface)	Daily
⑤	TRACKS, between track pads	Daily
⑥	SCREED CROWN, on chain	Weekly
	LEGEND	
	○ GREASE WITH SHELL AVANIA EP GREASE 2 OR EQUIVALENT.	
	□ SPRAY WITH FUEL OIL OR CHAIN LUBE	

MAINTENANCE ADJUSTMENTS

TO RAISE FEEDERS

1. Fold hopper wings all the way in and pull bolts out. Grab top wings and pull out 5" or 6", then pull bottom handle out til wing knuckles out. To let wings down just pull on top of wing and let down to where bolts will go in. See figure 30.

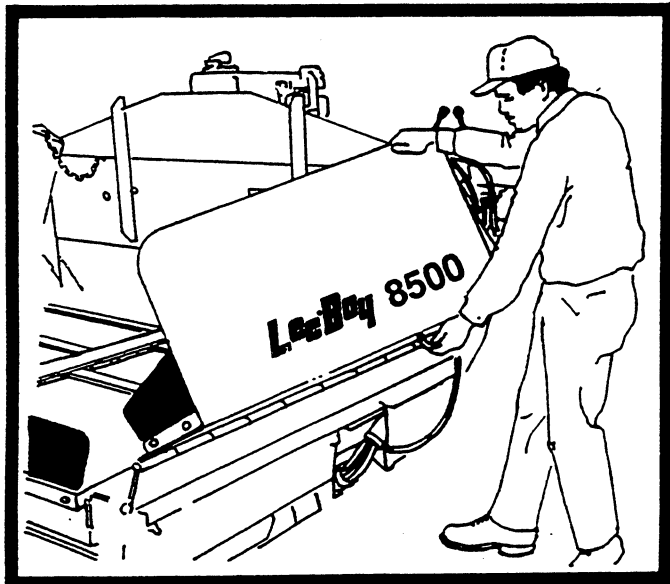

FIGURE 30

2. Raise feeders by pushing feeder lift valve forward. The location of this valve has purposely been placed in an inconvenient position to prevent the accidental raising of the feeders. See Figure 31.

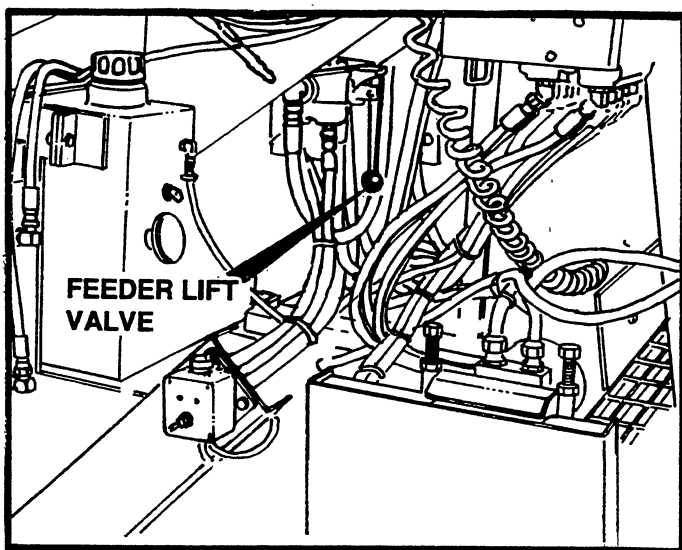

FIGURE 31

3. IMMEDIATELY AFTER RAISING FEEDERS, PLACE THE SAFETY PROP IN POSITION. See figure 32.

4. After the feeder is in position, lower the feeder onto the safety prop. This will provide an extra margin safety preventing safety prop from accidentally being dislodged.

! CAUTION !

BEFORE RAISING OR LOWERING FEEDERS, FOLD SIDES INTO THE FULL IN POSITION.

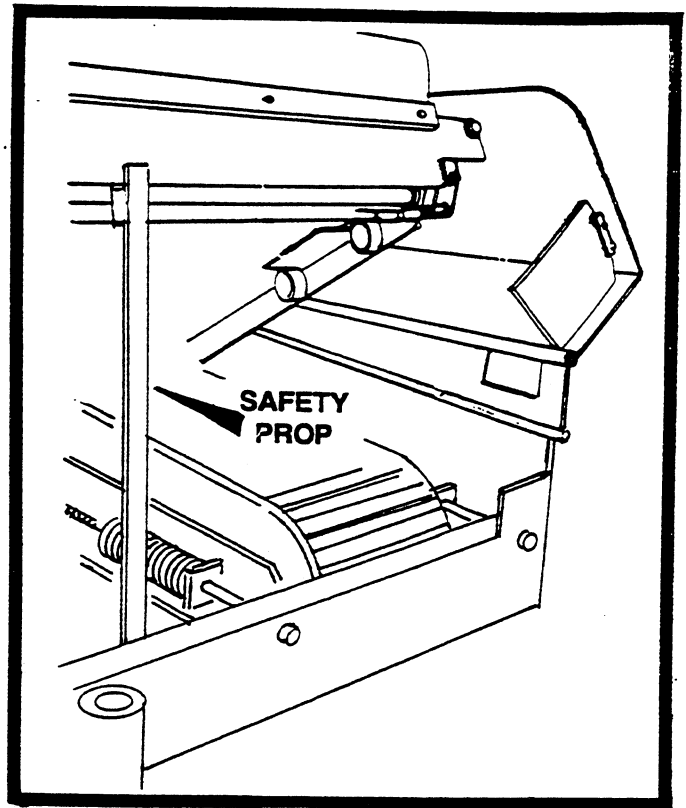

FIGURE 32

! DANGER !

USE EXTREME CAUTION WHEN WORKING UNDER FEEDERS. CLEAR AREA OF UNTRAINED PERSONNEL. PLACE SAFETY PROP INTO SUPPORT POSITION AND LOWER FEEDERS UNTIL SAFETY PROP IS UNDER LOAD AND FIRMLY WEDGED.

LOWERING FEEDER

1. Before lowering the feeder, make sure that the area under the feeder is clear of tools or foreign objects.
2. Release safety prop carefully. If feeder has dropped firmly down onto safety prop, it will be necessary to raise the feeder. After raising the feeder, turn engine off and release safety prop as instructed.
3. Lower feeder, but not under pressure. Allow feeder to come down with engine not running.
4. Fold side panels back with same in and out knuckle motion used to raise them.
5. Replace the hold down bolts on each side panel, and tighten.

! CAUTION !

NEVER PAVE WITH HOLD DOWN BOLTS OUT. HINGE FLAP MAY LIFT, LETTING ASPHALT GET INTO FLIGHT CHAIN.

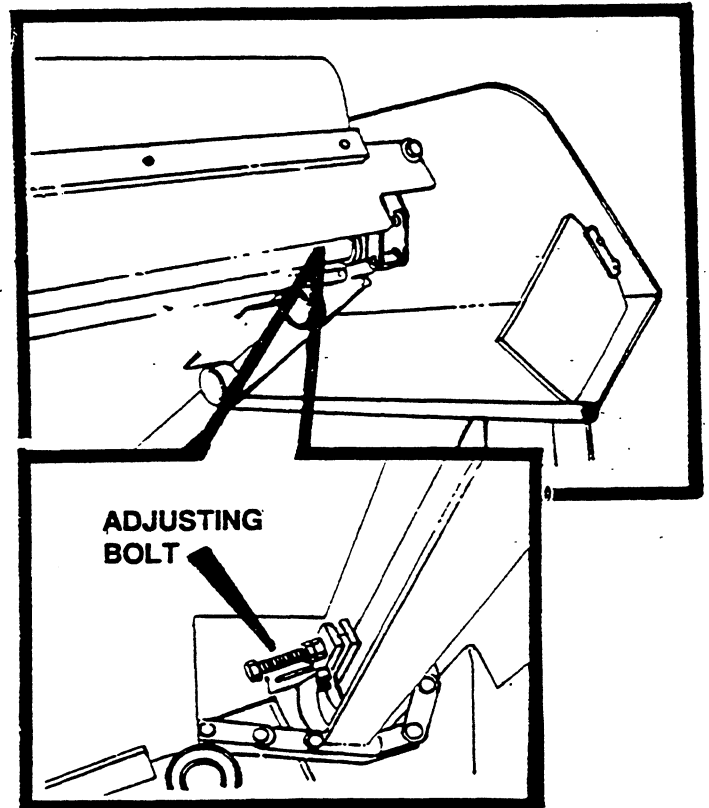

FIGURE 33

FEEDER FLIGHT CHAIN ADJUSTMENT

1. Raise feeders.
2. Secure safety prop to prevent feeders from accidentally lowering.
3. The feeder conveyor should run smooth when feeder chain is properly adjusted. These chains should be adjusted every 100 hrs., to maintain smooth operations. If irregular movement of the conveyor occurs, this is generally a sign that an adjustment is needed. Follow the procedures below in making this adjustment.
 - a. Refer to figure 33 and loosen the lock nut.
 - b. Turn adjustment bolts alternatively on both sides of the feeder. You can feel the pressure on the chain as you tighten the bolts. (We recommend turning one bolt one half turn then the other bolt one half turn. Continue alternating tightening until chains are tight).
 - c. After the feeder chain tension is set, tighten lock nuts.
 - d. If the adjustment bolts have been run out, it will be necessary to remove a link in the feeder chains and add a half link. This repair should bring the adjustment bolts back to full travel.

AUTOMATIC TRACK ADJUSTMENT

General

Hydraulic Adjustment Cylinders provide even tension on track which prevents excessive wear to paver undercarriage. This feature, however, will require the operator when backing with load to maintain at least one half throttle setting. Hydraulic pressure below one half throttle is not adequate to maintain track adjustment.

FAILURE TO MAINTAIN ADEQUATE THROTTLE SETTING MAY CAUSE IMPROPER ADJUSTMENT TO TRACK.

! CAUTION !

WHEN BACKING THIS MACHINE WITH LOAD, MAINTAIN AT LEAST A ONE HALF THROTTLE SETTING: FAILURE TO DO SO MAY CAUSE IMPROPER TRACK TENSION, RESULTING IN POOR PERFORMANCE AND DAMAGE.

DIRECTIONAL CONTROL ADJUSTMENT

GENERAL

There are two adjustments required to make the machine run straight. One is to the control cables, the other is to the adjustment screws located on each torque hub motor. To keep the machine running straight follow the instructions below.

FORWARD OR REARWARD (cable correction)

When starting forward with forward/reverse levers, push handles together. If machine veers left or right adjustment is required. Make adjustment to control cable clevis connection at the pump. This may be done by adjusting cable clevis. After adjustment, pumps should be in sequence.

FEEDER DRIVE CHAIN

1. Lower feeders.
2. Operate feeders.
3. Look at drive chain through the top of the frame. If drive chain has a whip in it, adjustment is necessary. See figure 35.
4. If adjustment is necessary, continue to operate feeders at fast speed and loosen the lock nuts on the chain adjustment. Turn the chain adjuster until the whip in the drive chain disappears.
5. Perform the same check on the opposite feeder chain.

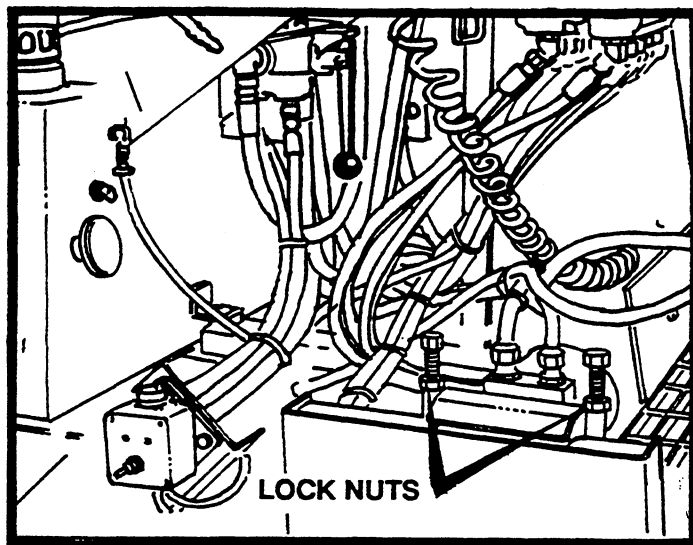

FIGURE 35

AUGER DRIVE CHAIN

1. The auger chains should be just snug, not loose. To snug up, loosen bolts in slots provided for takeup. See figure 36.
2. Use a pry bar under hydraulic motor and pry to tighten chain. Twist auger forward and rearward by hand to feel play in chain. (1/4" of play in chain is recommended.)

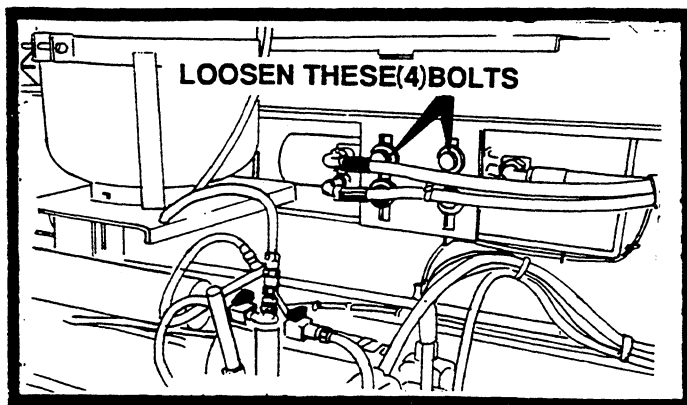

FIGURE 36

! DANGER !

DO NOT SUBSTITUTE FASTENERS OF ANY KIND UNLESS THEY ARE EQUAL IN SIZE AND GRADE AS ORIGINAL EQUIPMENT.

CONVEYOR LIMIT SWITCH

LIMIT SWITCH ADJUSTMENT

In order to have the 'off' and 'on' actuation of the conveyor start and stop occur at the right position, small adjustments may be necessary. These adjustments will be to the micro switch located on the conveyor flap. There are two positions of the conveyor flap, one upper, shutting the conveyor off, and one lower, turning the conveyor on. Read the following procedures carefully referring to the figures as needed.

1. See figure 37 and raise the conveyor flap 6 1/2" to 7" from bottom of Tank Mount Support. Secure conveyor flap so it remains in this position. If micro switch clicked "off" within the 6 1/2" to 7" limit, no further adjustment is required to the upper travel.
2. If micro switch did not click 'off', adjustment is needed. Remove the linkage attaching the actuator arm to the eyelet on the flap pivot housing. (See figure 37).

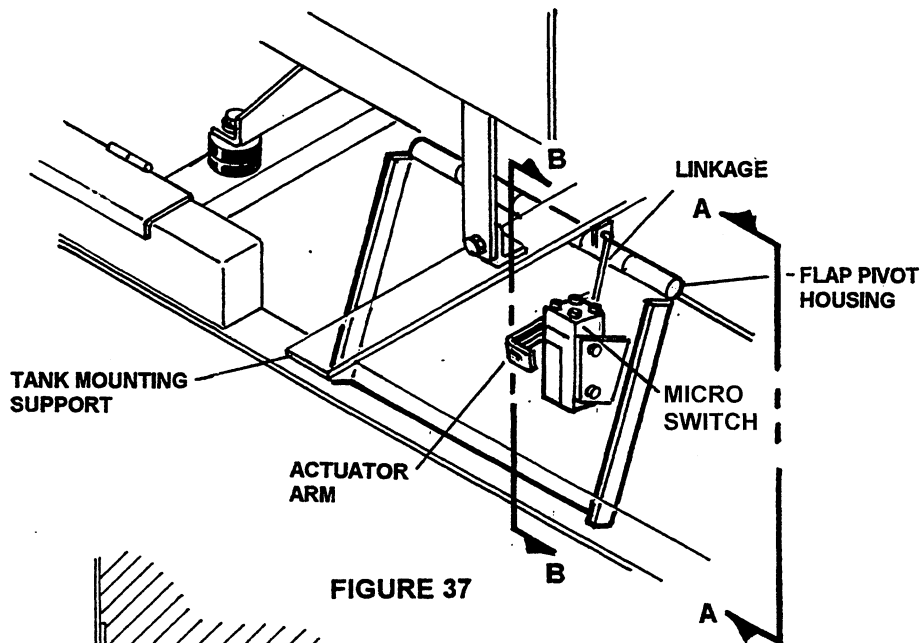
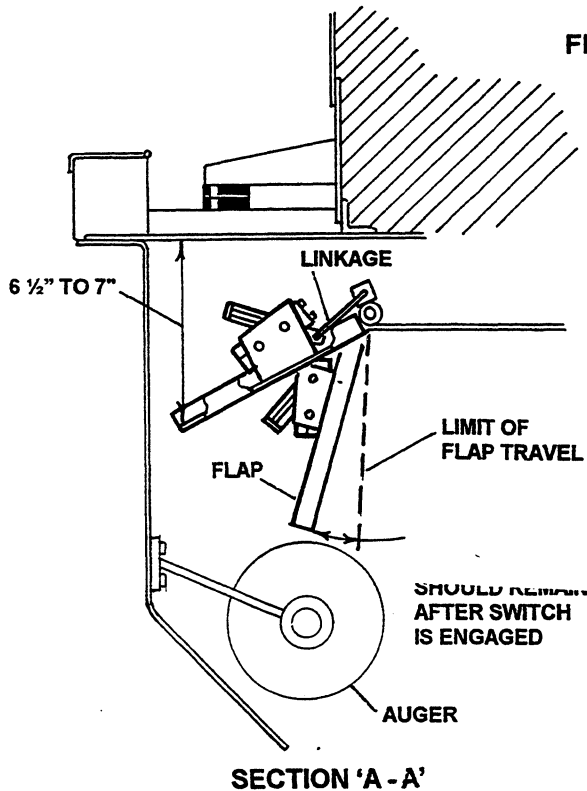
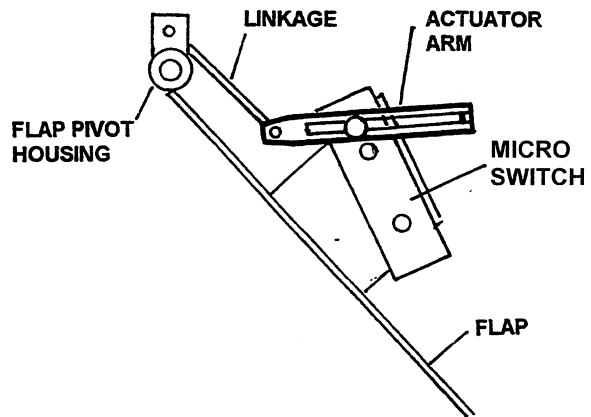

FIGURE 37



SECTION 'A - A'



SECTION 'B - B'

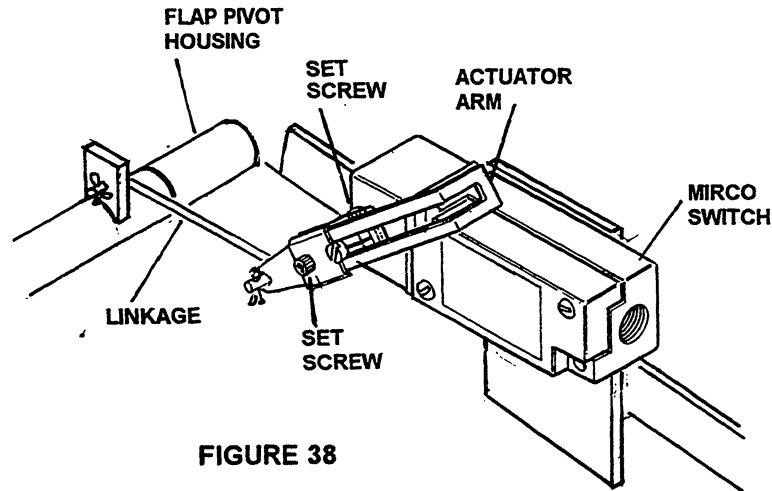

FIGURE 38

3. See figure 39 and loosen set screw on actuator arm. Reposition this arm by either rotating it clockwise or counterclockwise depending where the micro switch clicked "off" during the conveyor flaps upper travel.

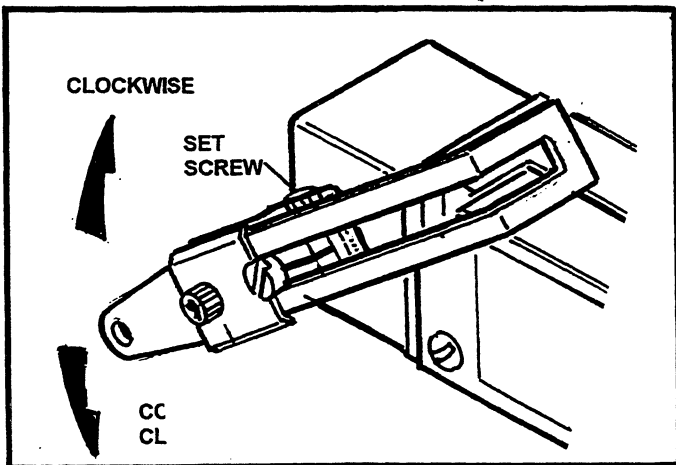

FIGURE 39

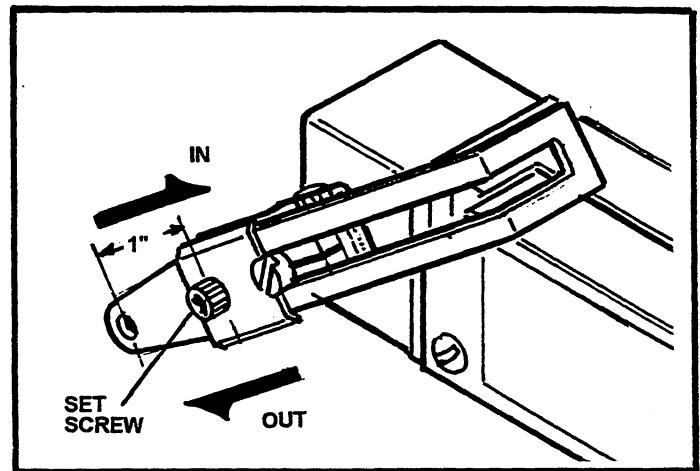

FIGURE 40

4. When the click 'off' occurs between the 6 ½" to 7" limit, tighten set screw and connect linkage. (See figure 39).
5. If the lower flap travel does not fall into the lower limits, loosen set screw on the actuator arm slightly. (The setting from the factory is 1" from the center of the set screw to the eyelet on the actuator arm). To help bring the travel limits into Tolerance, slide the actuator arm in the direction desired. This may require several adjustments before the correct position is obtained. When the actuator arm is determined to be correct, tighten set screw. No further adjustment is necessary. (See figure 38 & 40).

Trouble Shooting Guide

Problem	Probable Cause	Solution
Auger hanging up or will not turn	<ul style="list-style-type: none"> • Chain too loose • Chain broke • Bad motor • Asphalt set up around auger 	<ul style="list-style-type: none"> • Adjust • Replace • Replace • Keep clean and fuel oiled
Screed extensions hanging	<ul style="list-style-type: none"> • Asphalt set up around extension 	<ul style="list-style-type: none"> • Keep cleaned and fuel oiled
Screed extensions loose (work up and down)	<ul style="list-style-type: none"> • Out of adjustment 	<ul style="list-style-type: none"> • Adjust hold downs on extensions
Screed leaving streak down center of pavement	<ul style="list-style-type: none"> • Screed too flat (on leading edge) • Screed worn out • Extensions set too low 	<ul style="list-style-type: none"> • Crown leading edge of screed • Replace • Adjust Extension
Flight Screw Locking up	<ul style="list-style-type: none"> • Twisting screed too far • Screw Seized 	<ul style="list-style-type: none"> • Give screed time to react • Replace Screw
Breaking of flight screw bearings	<ul style="list-style-type: none"> • Loading and unloading 	<ul style="list-style-type: none"> • Check ramps for easy access
Flame coming out end of screed	<ul style="list-style-type: none"> • Raw gas from burners 	<ul style="list-style-type: none"> • Adjust burners in or out of hole. • Turn cutoff valve slowly to off, when flame goes out turn valve back on fully.
Hydraulic oil running out of breather cap	<ul style="list-style-type: none"> • Too full hydraulic oil • Air in bottom of tank • Oil over heated 	<ul style="list-style-type: none"> • Drain 5" to 6" from top of tank • Bleed if you don't have vent hose • Slow machine down about 10% to 15% • Check oil cooler & thermostat
Auger handles will not Stay locked in	<ul style="list-style-type: none"> • Detent worn out 	<ul style="list-style-type: none"> • Replace detent
Hydraulic pump cavitating or lost power	<ul style="list-style-type: none"> • Low hydraulic oil • Clogged filters • Suction hose loose • Charge pump worn 	<ul style="list-style-type: none"> • Fill • Replace • Retighten • Rebuild
Engine will not start (Diesel)	<ul style="list-style-type: none"> • Check Safety Switches Bad • Wires not making good connection on solenoid • Plug in switch box unplugged • Solenoid plunger sticking • Fuel solenoid coil burnt up • Blower belt broke 	<ul style="list-style-type: none"> • Replace • Make sure wires are tight • Plug back • Clean plunger • Replace coil • Replace Belt

Trouble Shooting Guide

Problem	Probable Cause	Solution
Machine will not run straight	<ul style="list-style-type: none"> • Quadco out of adjustment • Lee-Boy Drive Control 	<ul style="list-style-type: none"> • Adjust Cables
Machine will not pull on one or both sides	<ul style="list-style-type: none"> • Shifter out of adjustment • Keys sheared in bull gear (Transmission) • Transmission Gear stripped • Bad Drive motor 	<ul style="list-style-type: none"> • Readjust • Replace keys • Replace Gear • Replace
Tracks not running smooth	<ul style="list-style-type: none"> • Tracks too loose 	<ul style="list-style-type: none"> • Tighten tracks
Feeder does not work on one or both sides	<ul style="list-style-type: none"> • Switch on automatic flaps out of adjustment • Wires on solenoid loose - not making good connection • Plunger sticking valve • Solenoid coil burnt up • Switch worn out • Toggle switches bad • Relief in valve stuck • Feeder drive chain broke • Feeder drive motor bad 	<ul style="list-style-type: none"> • Adjust switch to where it clicks both ways • Adjust • Clean plunger, push manual . override • Replace coil • Replace switch • Replace • Take out, clean & install • Replace • Replace
Feeder flight bars hanging up	<ul style="list-style-type: none"> • Flight chains too loose • Feeder drive chain too loose 	<ul style="list-style-type: none"> • Adjust If adjusted all the way and a link is removed you must install a 1/2 link. • Adjust
Loss of power to drives Feeders or Augers	<ul style="list-style-type: none"> • Relief out of adjustment • Piston Groups worn in • Piggy back worn 	<ul style="list-style-type: none"> • Check pressure • Replace • Replace
Electric Screed don't work	<ul style="list-style-type: none"> • Check Fuse • Check wiring • Bad activator • Bad Switch 	<ul style="list-style-type: none"> • Replace • Make sure wires in tack • Replace • Replace

Hydraulic Pressures

Drive	• 3000PSI
Feeders	• 2400 PSI
Augers & Cyl.	• 2000 PSI

PARTS SECTION
(LIST OF ILLUSTRATIONS)

	PAGE
TRACK DRIVE ASSEMBLY	1
CONVEYOR DRIVE ASSEMBLY	3
HOPPER COMPONENTS	6
AUGER ASSEMBLY	8
CONVEYOR DRIVE, CUTOFF	10
HYDRAULIC COMPONENTS	12
MAIN VALVE AND SPRAYDOWN	14
RIGHT HAND DRIVE ASSEMBLY	16
PUMP COMPONENTS	18
ENGINE AND PUMPS	20
FILTER ASSEMBLY HATZ ENGINE	22
EXTENDABLE SCREED ASSEMBLY	24
BB EXTENSION SCREED ASSEMBLY	27
VIBRATOR ASSEMBLY	29
LEGEND SCREED ARMS	31
PROPANE HEATERS AND HOSES	33
JOINTER ASSEMBLY	35
UMBRELLA ASSEMBLY	37

MAJOR WEAR PARTS

PART NO.	DESCRIPTION
310080	FUEL FILTER HATZ
290030	HYDRAULIC FILTER
310070	OIL FILTER HATZ
320090	BELT, HATZ ENGINE
320360	BULB, CONTROL PANEL
320380	KEY, ENGINE
310060	AIR CLEANER HATZ ENGINE
870030	BEARING



PARTS INFORMATION

In order to expedite locating and shipping of parts you may need, please refer to the following information:

1. All parts must be ordered by a LeeBoy dealer.
2. The model and serial number of the unit should be given when ordering parts.
3. Parts should be ordered by part number and description.

688 North Highway 16 ~ Denver, North Carolina 28037
www.lee-boy.com ~ (704) 483-9721

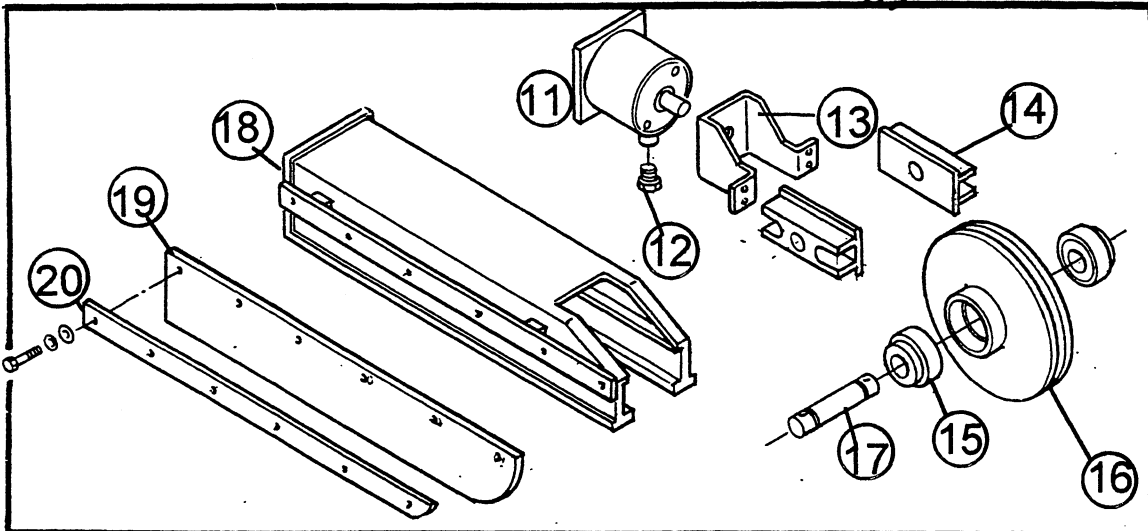
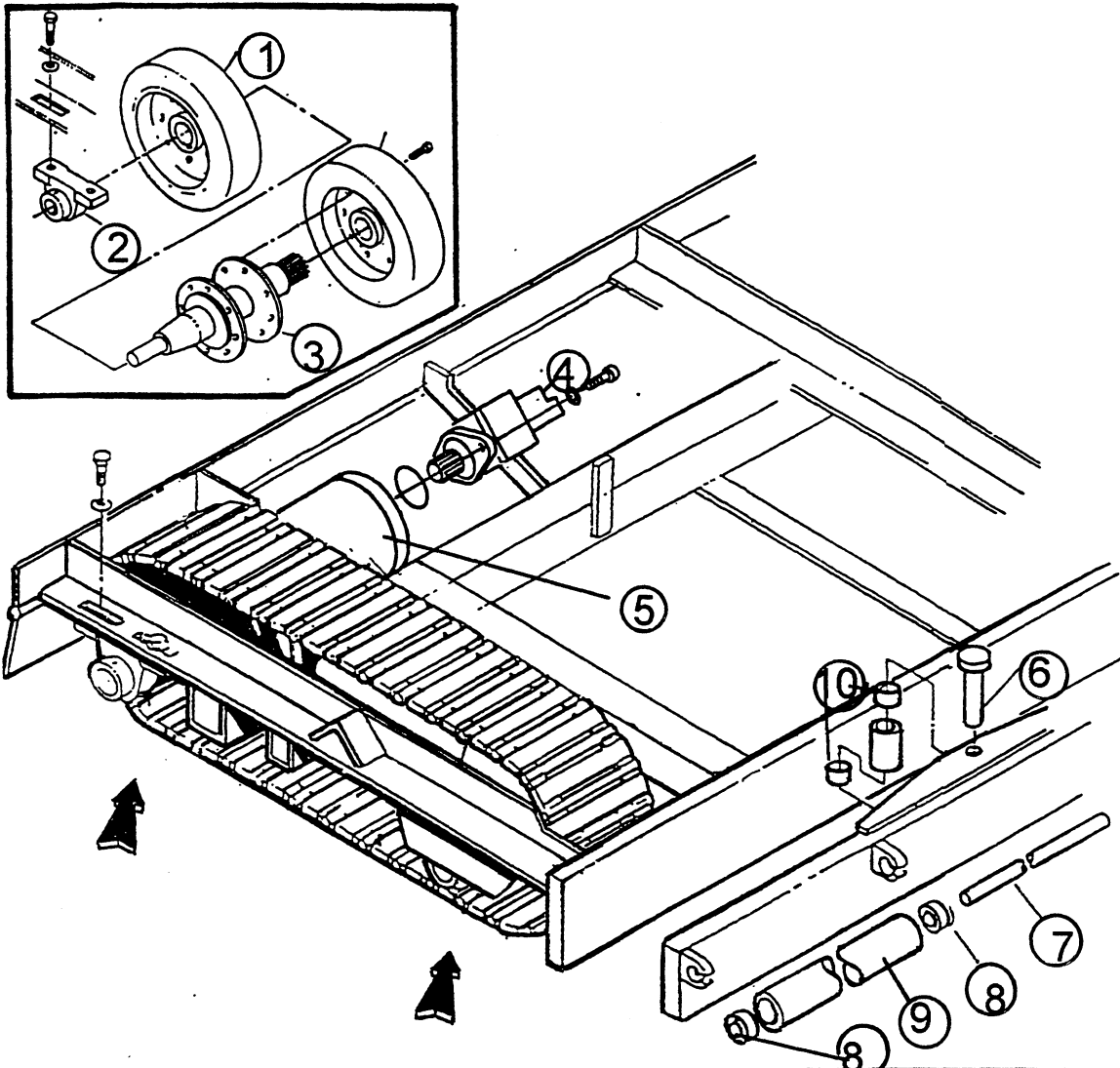

TRACK DRIVE ASSEMBLY



ITEM NO.	PART NO.	DESCRIPTION	QTY.
1	810286	MOLDED WHEEL & TIRE (6 X 16)	4
2	810140	BEARING, 2 1/4" PILLOW BLOCK	2
3	810285	REAR AXLE	2
4	811361	MOTOR	2
5	811360	TORQUE HUB, FINAL DRIVE (1000, 8000 & 8500 *	2
6	810081	PIN; PIVOT *	1
7	810122	SHAFT, PUSH ROLLER *	2
8	810110	BEARING, PUSH ROLLER (1 1/4")	4
9	810102	PUSH ROLLER, TRUCK WHEEL *	2
10	810070	BUSHING, TRACK IDLER / TRUCK HITCH	2
11	811331	HYD. CYL., TRACK TENSIONER	2
11A	851485	SEALKIT , TRACK TENSION CYLINDER	A/R
12	851644	BREATHER; CYLINDER	2
13	811333	YOKE, TRACK IDLER	2
14	811334	SIDE BLOCKS	4
15	420090	BEARING, 400 FRONT AXLE	4
16	811337	WHEEL, 7000 TRACK IDLER	2
17	811336	SHAFT, 7000 TRACK IDLER	2
18	811324	SIDE FRAME COMPLETE *	2
19	810020-8000	SHIELD, TRACK RUBBER GUARDS	4
20	810031-8000	CLAMP, TRACK RUBBER GUARD	4
21	811335	IDLER ASSY., INCLUDES #14 HTRU 17	A/R
22	811329-1	BOLT, TRACK IDLER YOKE	A/R

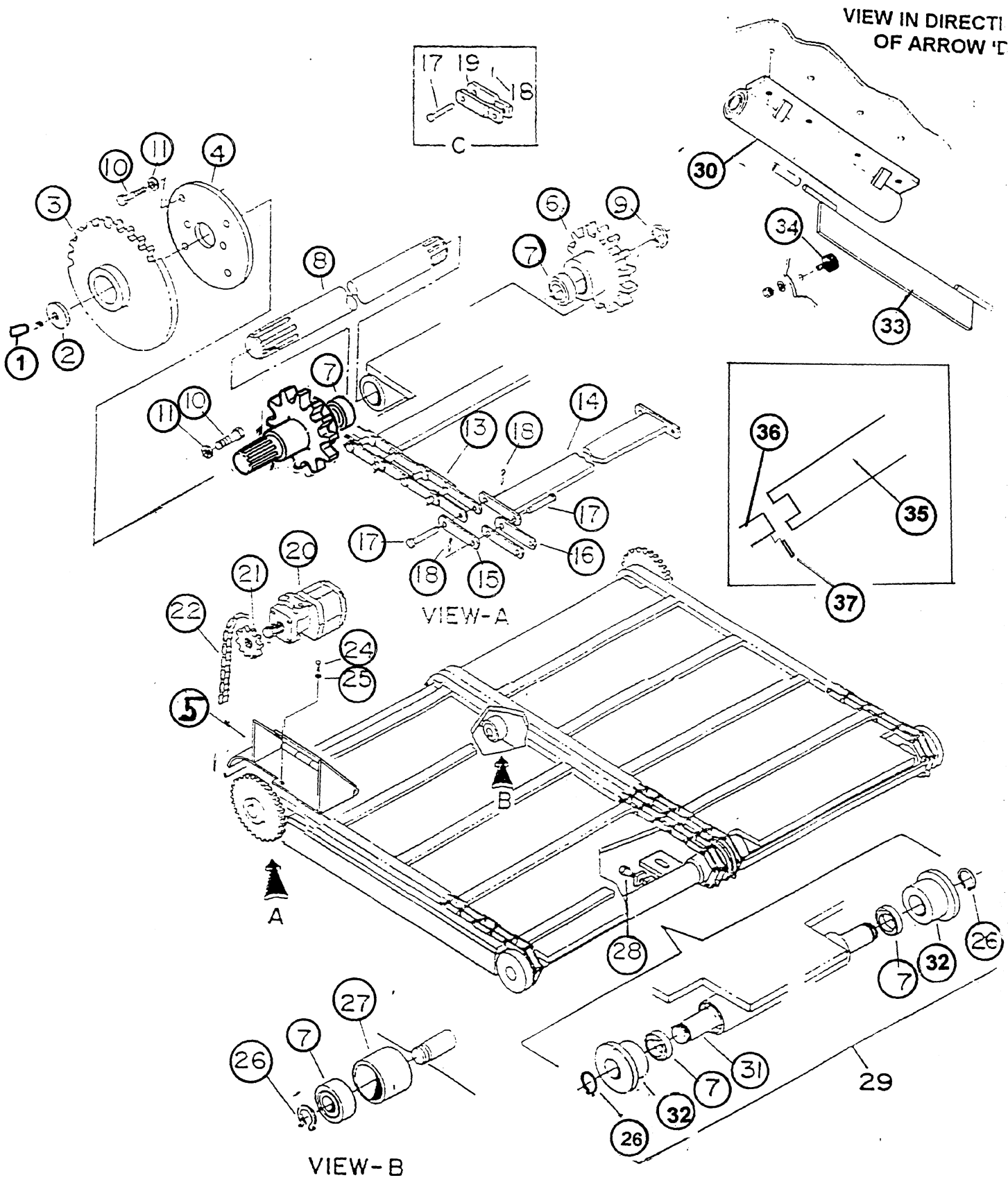

CONVEYOR DRIVE ASSEMBLY



ITEM NO.	PART NO.	DESCRIPTION	QTY.
	851626	CONVEYOR, WELDMENT ONLY	
	851627	8500 CONVEYOR PLATE WELDMENT	
1	851111	BOLT; TAPER HEAD 1/2IN	2
2	851112	WASHER;COUNTER SUNK 1/2	2
3	851473	SPROCKET; OUTER DRIVE [80]	2
4	851483	CONVEYOR MOUNTING PLATE WITH BEARING	2
5	850038	DEFLECTOR, L/R SPECIFY	2
6	850030	SPROCKET; INNER DRIVE C-188	2
6A	851474	SPROCKET; OUTER DR. C-188	2
7	851130	BEARING, AUGER, AXLE, IDLER	20
8	851116	DRIVE SHAFT, CONVEYOR	2
9	850040	SNAP RING, CONVEYOR DRIVE SHAFT *	2
10	850044	BOLT	A/R
11	860050	CONVEYOR CHAIN, 8000C (W / 10, 36-3/4" BARS)	2
12			
13	850070	MASTER LINK, CONVEYOR CHAIN (C-188) *	4
14	851118	CONVEYOR BAR,	A/R
15	850090	LINK PIN, CONVEYOR CHAIN (C-188)	A/R
16	850080	LINK BLOCK, (C-188)	A/R
17	850090	PIN	A/R
18	850100	PIN, COTTER	A/R
19	850215	HALF LINK, CONVEYOR CHAIN(C-188)	2
20	260130	HYD. MOTOR, MAIN AUGER (1200)	2
21	851120	SPROCKET,80 B8	2
22	851121	CHAIN, CONVEYOR DRIVE	2
23			
24		BOLT	6
25		WASHER;COUNTER SUNK 1/2	A/R
26	850040	SNAP RING, CONVEYOR DRIVE SHAFT *	A/R
27	850162	GUIDE ROLLER, CONVEYOR CHAIN	4
28	850170	BOLT, ADJUSTING	4

CONVEYOR DRIVE ASSEMBLY



ITEM NO.	PART NO.	DESCRIPTION	QTY.
29	851123	CHAIN GUIDE ASSY., CONVEYOR FRONT *	2
30	851651	TUBE ASSEMBLY [REAR]	2
31	850120	IDLER, CONVEYOR CHAIN	A/R
32	850120	GUIDE; CHAIN *	4
33	851128	SCRAPER; CONVEYOR	2
34	410070	STOP,RUBBER	2
35	851118A	CONVEYOR BAR, QUICK CHANGE	A/R
36	851118-2	TAB, WELDMENT (QUICK CHANGE FLIGHT BAR)	A/R
37	851118-1	PIN, ROLL PIN (3/8"x 2")	A/R

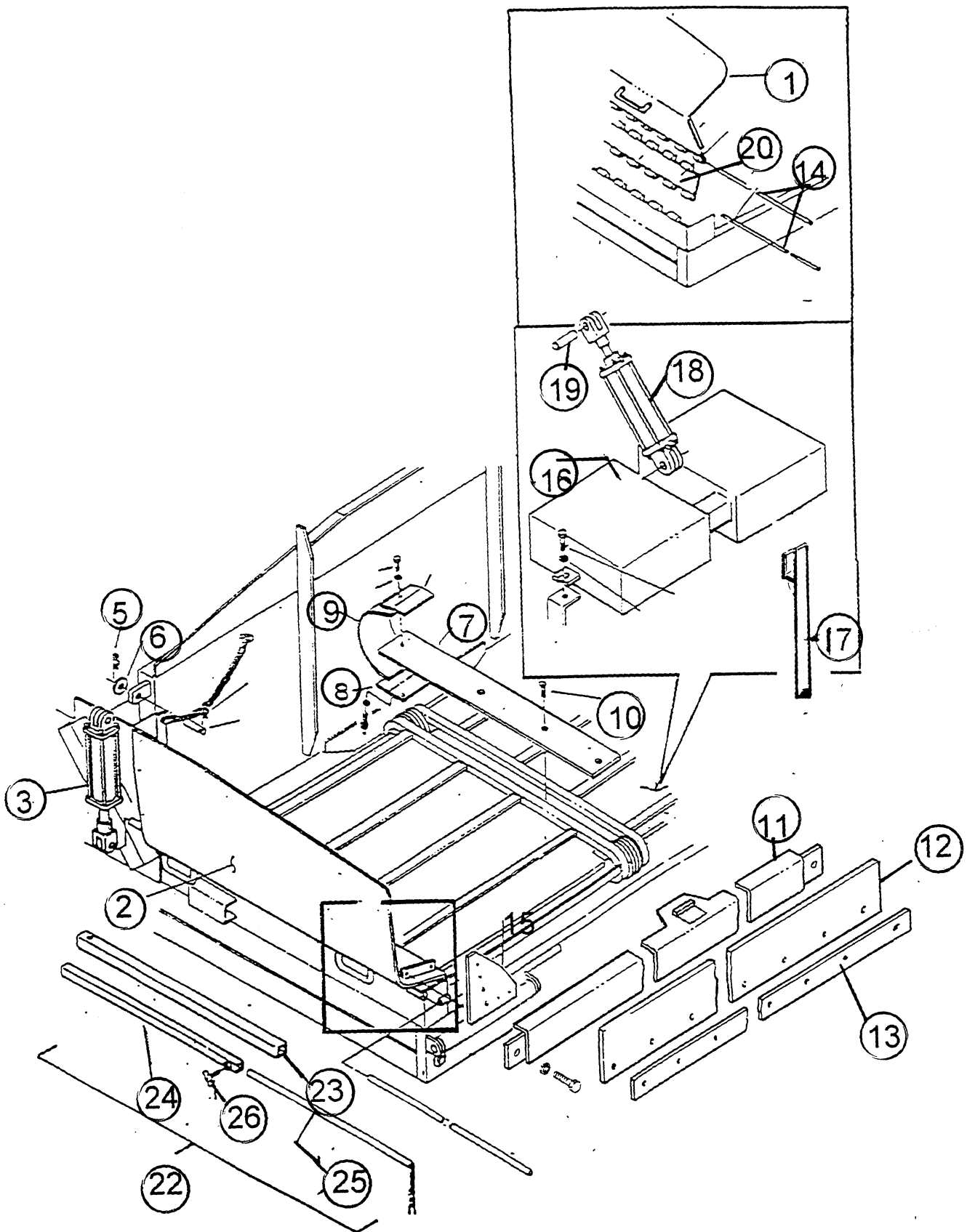

HOPPER COMPONENTS



ITEM NO.	PART NO.	DESCRIPTION	QTY.
1	840050	PANEL,HOPPER SIDE,R/H	1
2	840060	PANEL,HOPPER SIDE,L/H	1
3	840030	HYD. CYL., HOPPER WING (8000 / 8500)	2
3A	851484	UNIVERSAL SEAL KIT, CYLINDER	A/R
4	851132	PIN *	2
5	870307	CLIPS; (FOR PINS) *	4
6		WASHER, FLAT 1"	2
7	840043	SHIELD; CHAIN *	2
8	840166	HOLD DOWN *	1
9	840162	CENTER SHIELD, CONVEYOR REAR *	1
10	851134	SCREW; TAPER (3/8)	6
11	851135	SHIELD; FRONT SUPPORT *	1
12	851136A	SHIELD,FRONT HARD RUBBER	1
13	851137	REINFORCEMENT; SHIELD BAR *	1
14	840072	PIN, PIVOT SIDE PANEL	4
15	840090A	SHIELD, SIDE CORNER RUBBER	2
16	851140	BOTTOM TANK, HYD. OIL (8000C / 8500)	2
17	840021	SAFETY PROP, HOPPER	1
18	840020	HYD. CYL., HOPPER LIFT (8000 / 8500) (3X12) *	1
18A	870311	UNIVERSAL SEAL KIT, HOPPER WING	A/R
19	240030	PIN	2
20	840156	HINGED PANEL *L/H	1
21	840157	HINGED PANEL, R/H	1
22	920032	GUIDE BAR ASSEMBLY *	2
23	920041	BAR; GUIDE (OUTER) *	2
24	920051	HOUSING; GUIDE BAR (INNER) *	2
25	920061	ROD & CHAIN, GUIDE BAR *	2
26	920070	WINGBOLT, GUIDE BAR LOCK	2

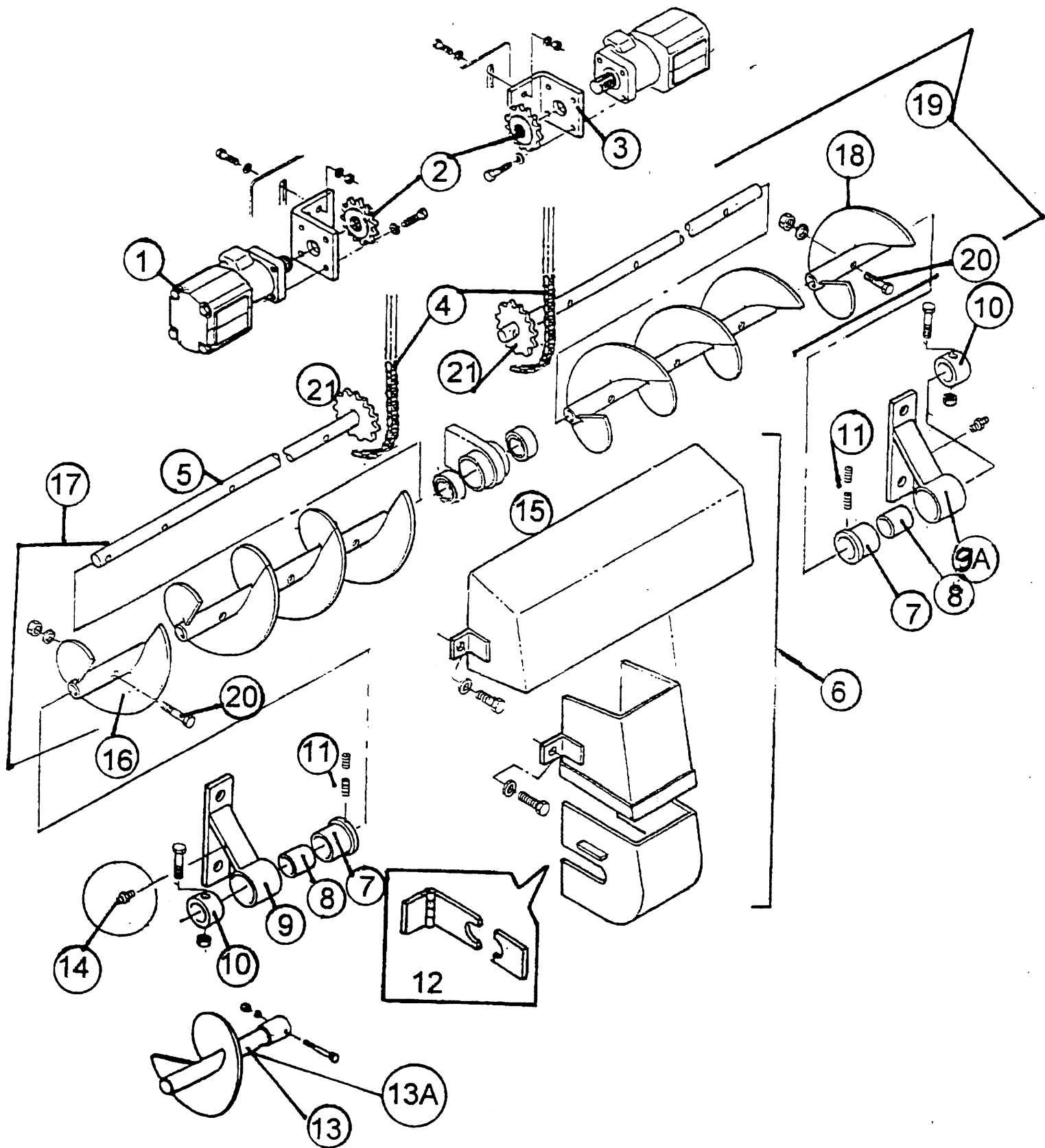

AUGER ASSEMBLY



ITEM NO.	PART NO.	DESCRIPTION	QTY.
1	860010	HYD. MOTOR, AUGER (ALL) / CONVEYOR (8000B)	2
2	860030	SPROCKET, AUGER DRIVE MOTOR (8000 / 8500)	2
3	860021	MOUNTING BRACKET, AUGER MOTOR *	2
4	860090	CHAIN, PAVER AUGER DRIVE	2
5	861130C	SHAFT W/ SPROCKET, CASTED AUGER	2
6	860043	COVER, AUGER CHAIN DRIVE (8000 / 8500)	1
7	851645	COLLAR, RETAINING CAP WITH BOLT	1
8	810070	BUSHING, TRACK IDLER / TRUCK HITCH	1
9	860051HDR	ENDMOUNT, R.H. AUGER	1
10	860051HDL	ENDMOUNT, L.H. AUGER	1
11	851645-1	SET SCREWS	2
12	860043-1	KIT, AUGER COVER CLOSING	2
13	860136	AUGER EXTENSION, R.H.	1
13A	860135	AUGER EXTENSION, L.H.	1
14	140610	GREASE FITTING	2
15	850130	BEARING	2
16	861140C	AUGER SECTION, R.H.	4
17	860083	AUGER ASSEMBLY, R.H.	1
18	861150C	AUGER SECTION, L.H.	4
19	860073	AUGER ASSY. L.H. (8000 & 8500)	1
20	861141	BOLT AND NUT, CASTED AUGER	8
21	860035	SPROCKET, AUGER SHAFT (WELD ON)	2
22	860012	SEAL KIT; HYD. MOTOR	2

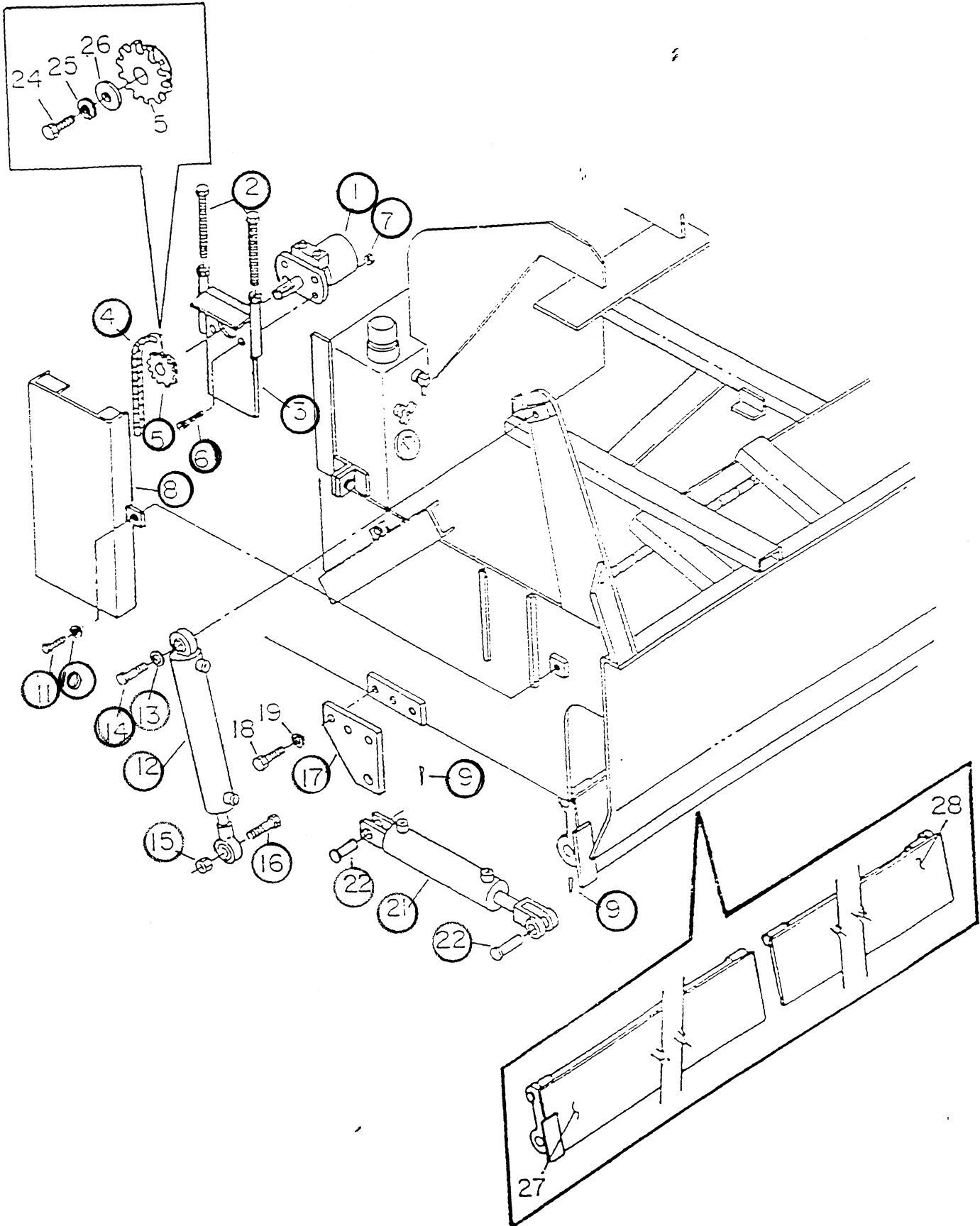

CONVEYOR DRIVE, CUTOFF



ITEM NO.		DESCRIPTION	QTY.
1	260130	MOTOR, HYDRAULIC CONVEYOR	2
2	851148	BOLT; ADJUSTER *	4
3	851149	MOUNT; ADJUSTABLE *	
4	851121	CHAIN, CONVEYOR DRIVE (8000 C & 8500)	2
5	851120	SPROCKET, CONVEYOR DRV. MTR. (8000C / 8500)	2
6	851150	BOLT, SHCS 1/2"	8
7		NUT, LOCK 1/2"	8
8	850041	Shield; Chain (Left or Right)	2
9		PIN, COTTER 3/16"x2 1/2"	4
10	860041	WASHER; LOCK (3/8	6
11		BOLT, HEX 3/8"x3/4"	6
12	851436	HYD. CYL., SCREED LIFT (1000C / 8000C / 8500)	2
12A	851484	UNIVERSAL SEAL KIT, SCREED LIFT CYLINDER	A/R
13		WASHER; LOCK (3/8	2
14		BOLT, HEX 1"x3" (FINE)	2
15		NUT, LOCK 1"	2
16		BOLT, HEX 5/8"x3 1/2" (FINE)	2
17	851152	MOUNT; CYLINDER *	2
18		BOLT, HEX 5/8"x3 1/2" (FINE)	6
19		WASHER, LOCK 5/8"	6
20			
21	910170	HYD. CYL., CUTOFF*	2
21A	870312	UNIVERSAL SEAL KIT, CUTOFF CYLINDER	A/R
22	240030	PIN	2
23			
24		BOLT 1/4"x1"	1
25	118-1	WASHER, LOCK (1/4")	1
26		WASHER, LOCK FENDER	1
27	851153	CUT-OFF LEFT SIDE *	1
28	851154	CUT-OFF RIGHT SIDE *	1

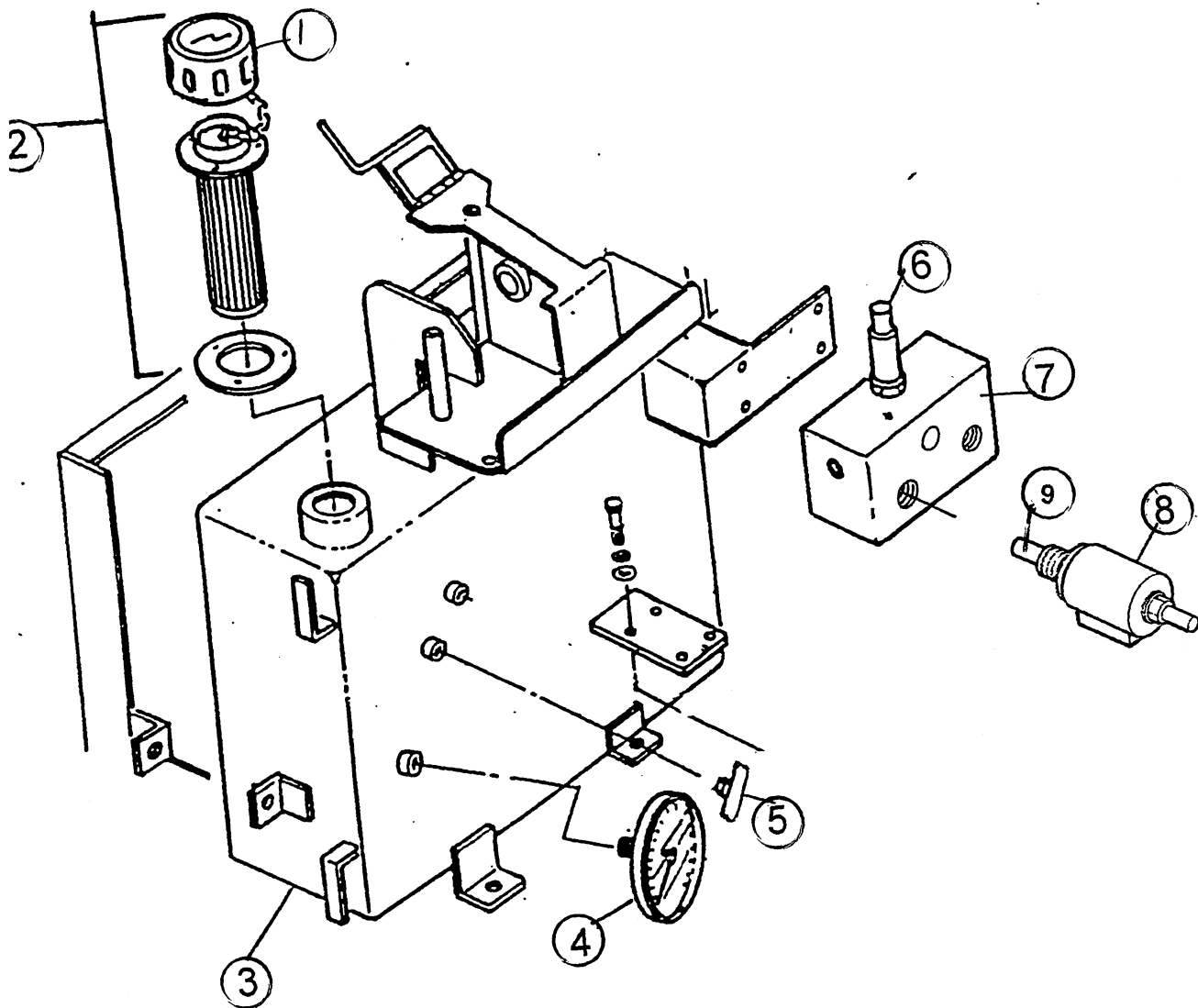

HYD. COMPONENTS



ITEM NO.	PART NO.	DESCRIPTION	QTY.
1	140030HL	LOCKABLE HYD. CAP	1
2	140030	CAP, FILLER STRAINER	1
2A	140030HL	HYD. TANK CAP, (LOCKABLE)	A/R
3	851233	TOP TANK ASSY., HYD. OIL (8500 LOW DECK) *	1
4	330040	GUAGE;TACK TEMP / HYD.OIL TEMP	1
5	910150	PETCOCK *	1
6	851628A-3	RELIEF VALVE,CONVEYOR MANIFOLD	1
7	851628A	MANIFOLD, CONVEYOR,(7000)	1
8	851628A-2	COIL,CONVEYOR MANIFOLD CARTILAGE VALVE	2
9	851628A-1	CARTRIDGEVALVE, CONVEYOR MANIFOLD	2

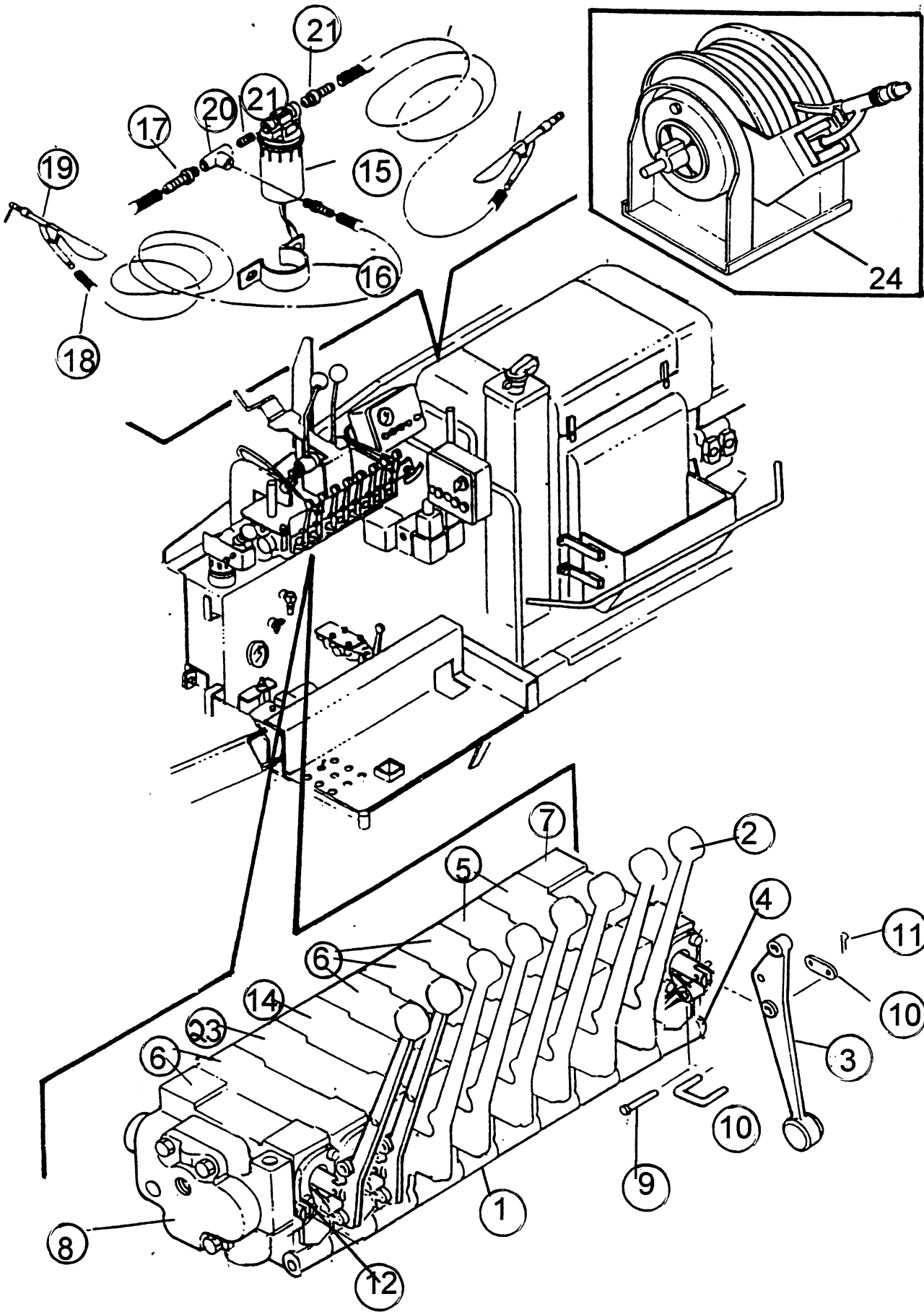

MAIN VALVE AND SPRAYDOWN



ITEM NO.	PART NO.	DESCRIPTION	QTY.
1	851161	VALVE ASSY., 8 SECTION W / FLOAT	1
2	910060	VALVE HANDLE, VERTICAL	8
3	910070	HANDLE, HORIZONTAL	0
4	901009	MAIN RELIEF VALVE, V-20 VALVE	1
5	910052	VALVE SECT., DETENTED (1000C,1200,8000C,8500)	2
6	910054	VALVE SECT., SPRING RET. (685,1200,8000C,8500)	5
7	910055	INLET COVER;V-20 (W/RELIEF)	1
8	910056	OUTLET COVER, V-20 (W / PB SLEEVE)	1
9	350080	PIN, CELVIS (1/4)	8
10	901010	LINK ASSY., VALVE LEVER	8
11	960019	PIN, COTTER (1/4)	8
12	910058	BRACKET;VALVE LEVER	8
13	901007	DETENT KIT;VALVE SPOOL	
14	141050	FLOAT KIT	
15	900010	PUMP, SPRAYDOWN (FLOJET) *	1
16	480260	BRACKET, PUMP (SPRAYDOWN)	1
17	920218	ADAPTER, 3/8" M.P.T. X 5/16" HOSE	3
18	920219	HOSE, FUEL WASHDOWN (5/16" I.D. X 15 FT. LONG	1
19	920220	HANDLE & NOZZLE, FUEL WASH-DOWN	2
20	920222	TEE; 3/8	1
21	920223	NIPPLE; 3/8	1
22	901210 A	TIPS, SPRAY HANDLE	2
23	910054FLS	FLOAT, ASSEMBLY SCREED	1
24	920200	HOSE REEL, MACHINE WASHDOWN	1
	910059	SEAL KIT;VALVE SPOOL	
	910062	SEAL KIT;VALVE SECTION	
	910065	KIT; SEAL (RELIEF VALVE) *	

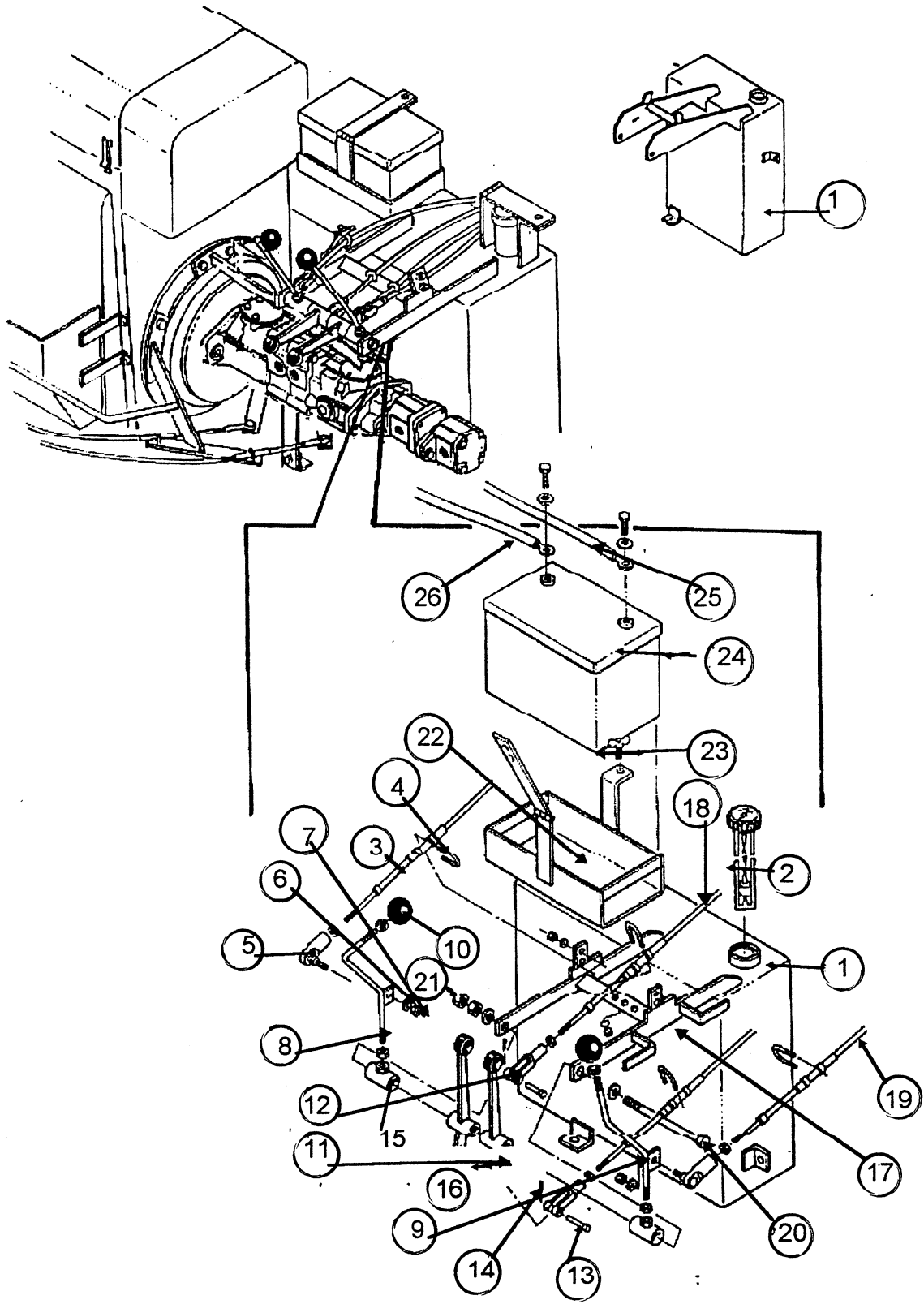

RIGHT HAND DRIVE ASSEMBLY



ITEM NO.	PART NO.	DESCRIPTION	QTY.
1	910009	FUEL TANK ASSY., 13 GAL. (1000B / 8000B) *	1
2	910010	FUEL CAP & GAUGE, 16" / 13 GAL. TANK	1
2A	140030FL	FUEL CAP, LOCKABLE	A/R
3	920140	CABLE, R.H. DRIVE / CONTROL (116" X 3" STROKE	1
4	350060	U-BOLTS, 3/8	3
5	920090	SPHERICAL ROD END, W / STUD	2
6	920072	LOCKWASHER, 3/8"	2
7	920093	NUT, 3/8"	2
8	920230	HANDLE; (R/H) (LEE-BOY) *	1
9	920228	HANDLE; DRIVE L/H (LEE-BOY) *	1
10	920225	KNOBS, ROUND	2
11	920210	CASTED HANDLE, R.H. CONTROL *	1
12	350050	CLEVIS, 1/4"	2
13	350080	PIN,(1/4)	2
14	960019	PIN, COTTER	2
15	350054	PIVOT; HANDLE *	2
16	350055	NUTS 1/2	2
17	350059	BRACKET; R/H DRIVE *	1
18	920140	CABLE, R.H. DRIVE / CONTROL (116" X 3" STROKE	1
19	920130	CABLE, R.H. CONTROL (123" X 3" STROKE)	1
20	920145	ROD FOR RIGHT HAND 5/8	1
21	920147	NUTS; JAM (5/8	2
22	920151	BOX; BATTERY *	1
23	920070	WING BOLT, (3/8)	3
24	920155	BATTERY, 12 VOLT 1000 CCA GROUP 31-5T	1
25	900147	CABLE, (-)	1
26	900148	CABLE, (+)	1

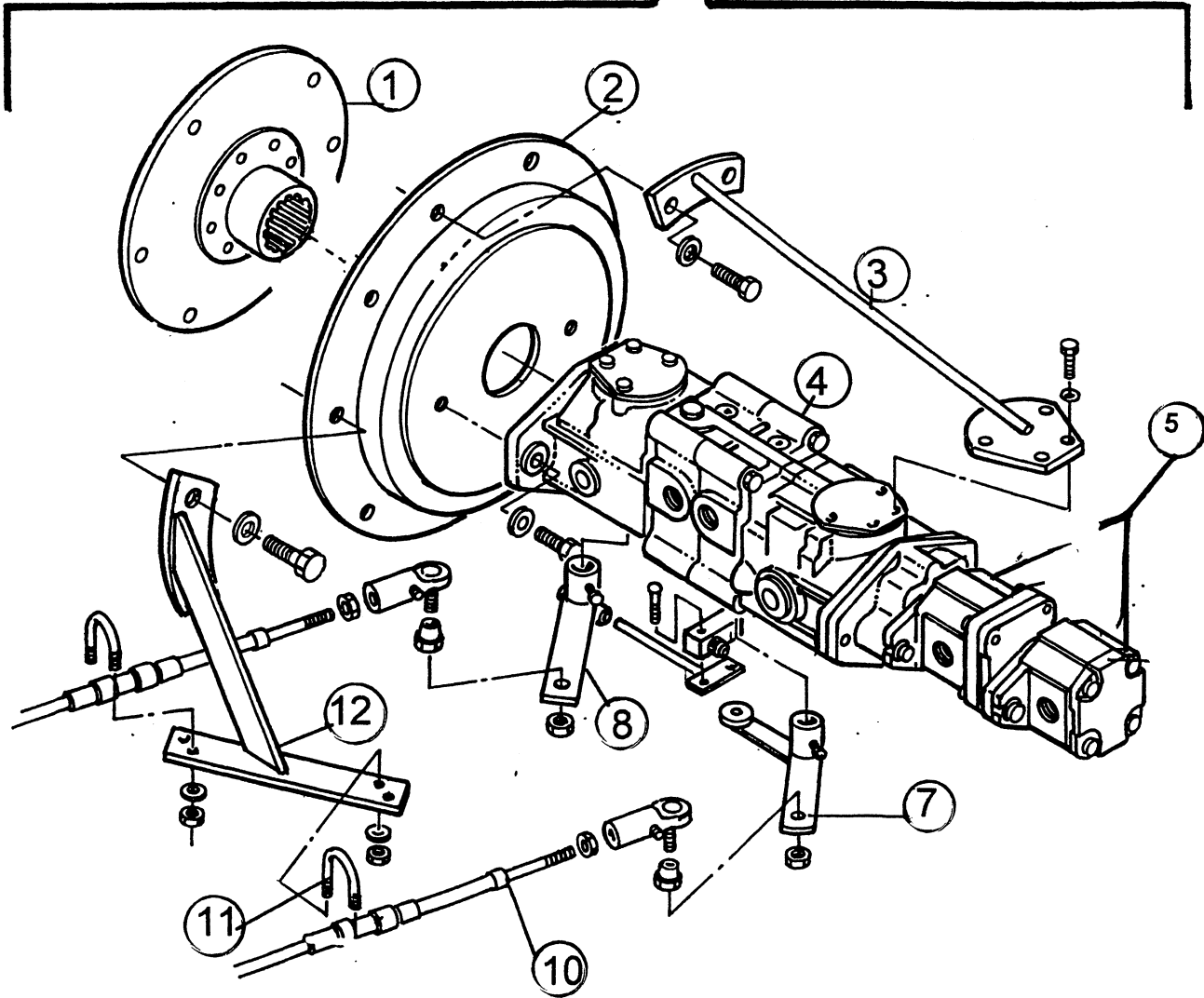
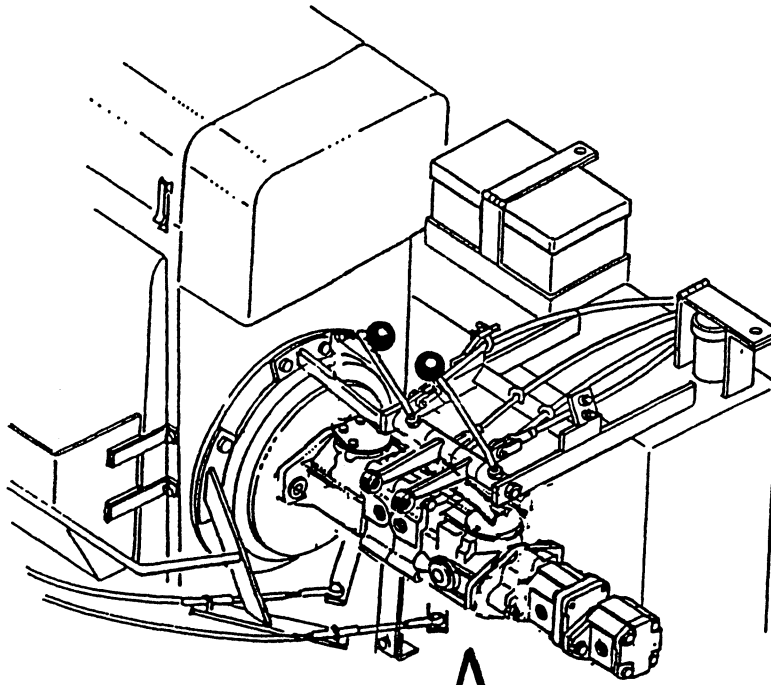

PUMP COMPONENTS



ITEM NO.	PART NO.	DESCRIPTION	QTY.
1	851479	PUMP DRIVE PLATE, FLYWHEEL	1
2	320200	COVER; PUMP PLATE	1
3	320224	BRACE; PUMP SUNSTRAND *	1
4	230237	PUMP DRIVE, SUNSTRAND	1
5	851160	TANDEM AUXILLARY PUMP, AUGERS & CONVEYORS *	1
6	320235	O-RING; PIGGYBACK *	1
7	900025	ARM; RIGHT DRIVE *	1
8	320245	ARM; LEFT DRIVE *	1
9	920090	SPHERICAL ROD END, W / STUD	2
10	920120	CABLE, R.H. DRIVE, AUGER & PUMP (104" X 3")	2
11	870289	3/8" WIRE ROPE CLAMP, SCREED LIFT CABLE	2
12	920125	BRACKET; PUMP CABLES *	1
13	320234	KIT; REBUILD *	1
14	320239	SEAL, INPUT SHAFT (SUNDSTRAND M46 / 435)	A/R
15	851495	INPUT SHAFT, SUNDSTRAND M91 *	A/R

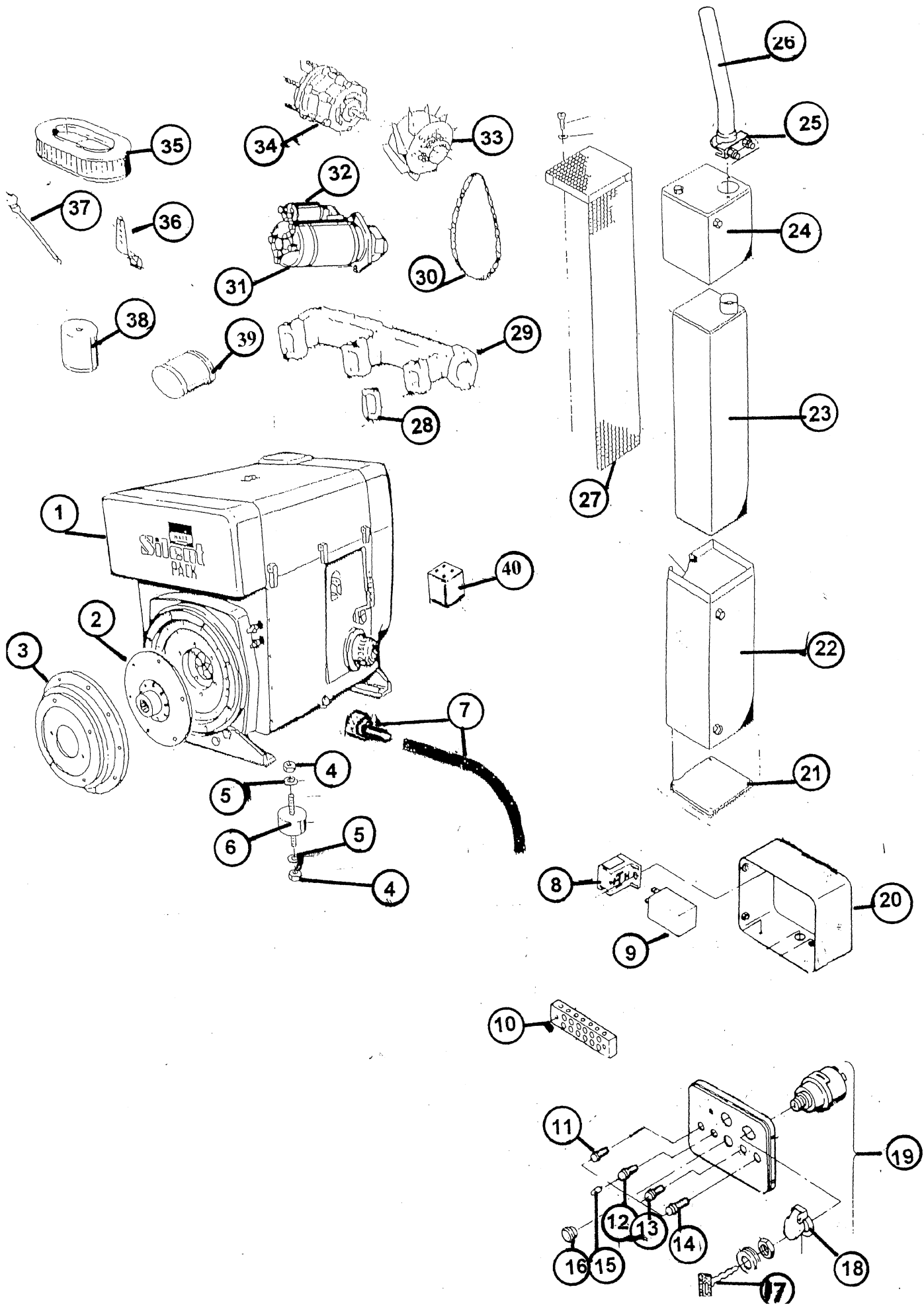

ENGINE COMPONENTS HATZ



ITEM NO.	PART NO.	DESCRIPTION	QTY.
1	320000	3 CYL. DIESEL ENG., HATZ 3L41C (SILENT-PAK)	1
2	851479	PUMP DRIVE PLATE, FLYWHEEL	2
3	320200	COVER; PUMP PLATE	1
4	320144	NUT, 10mm.	1
5	320142	WASHER, 10mm.	4
6	320140	MOUNTPAD, ENGINE HATZ	4
7	851497	HOSE & DRAIN FITTING, ENGINE OIL DRAIN	1
8	320330	MOUNT, STARTER RELAY	1
9	320320	RELAY, STARTER	1
10	320340	BLOCK; TERMINAL *	1
11	320383	INDICATOR LAMP, ENGINE TEMP	1
12	320385	INDICATOR LIGHT, AIR FILTER RESTRICTION	1
13	320384	INDICATOR LIGHT, ENG.OIL PRESS.	1
14	320386	INDICATOR LIGHT, BATTERY CHARGE	1
15	320360	LIGHT BULB, INDICATOR LAMP	4
16	320382	PLUGS *	1
17	320380	IGNITION KEY, HATZ DIESEL	1
18	320381	FLAP, IGNITION SWITCH	1
19	320390	IGNITION SWITCH, HATZ DIESEL	1
20	320375	INSTRUMENT BOX, W/ PANEL & SWITCH	1
21	HATO3878000	PLATE, MUFFLER BOTTOM	1
22	HAT00871801	COVER, MUFFLER BOTTOM	1
23	320422	MUFFLER, HATZ SILENT PACK	1
24	HATO1083000	COVER, MUFFLER TOP	1
25	320030	CLAMP, 2" EXH. PIPE	1
26	851164	PIPE EXT. MUFFLER *	1
27	320510	HEAT SHIELD, MUFFLER	1
28	320260	GASKET, EXH. MANIFOLD TO CYL. HEAD	3
29	320250	EXH. MANIFOLD, HATZ 3 CYL.	1
30	320090	BELT, ALTERNATOR / BLOWER	1
31	320270	STARTER MOTOR	1
32	320280	SOLENOID, STARTER	1
33	320290	BLOWER FAN	1
34	320300	ALTERNATOR, 12 VOLT	1
35	310060	ELEMENT, AIR FILTER	1
36	320120	LEVER, ENGINE THROTTLE	1
37	320110	DIPSTICK, ENGINE OIL LEVEL	1
38	310080	ELEMENT, FUEL FILTER	1
39	310070	ELEMENT, OIL FILTER	1
40	851567	SOLENOID, FUEL SHUT-OFF	1

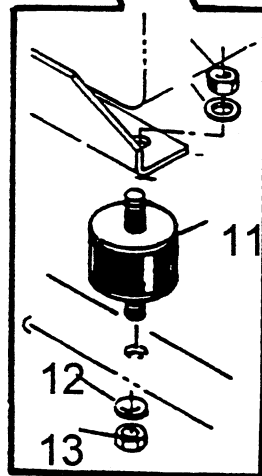
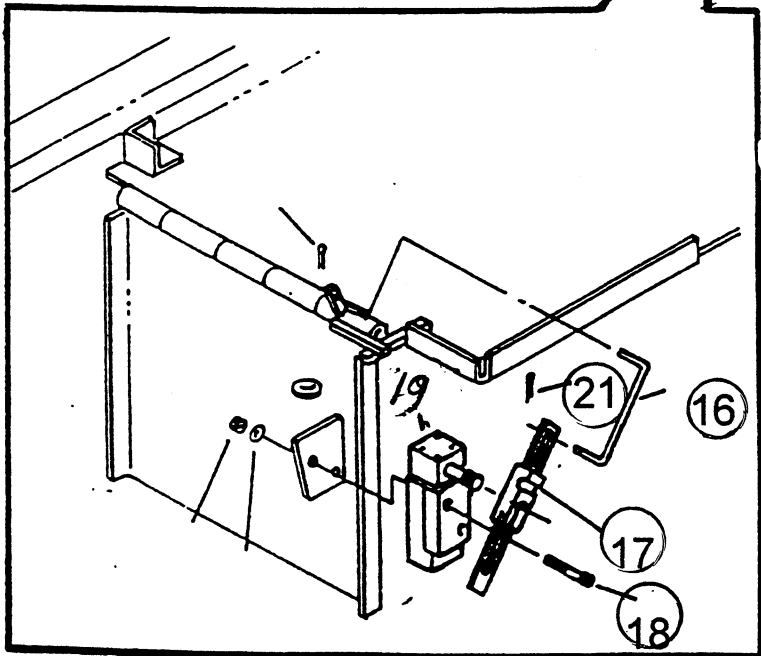
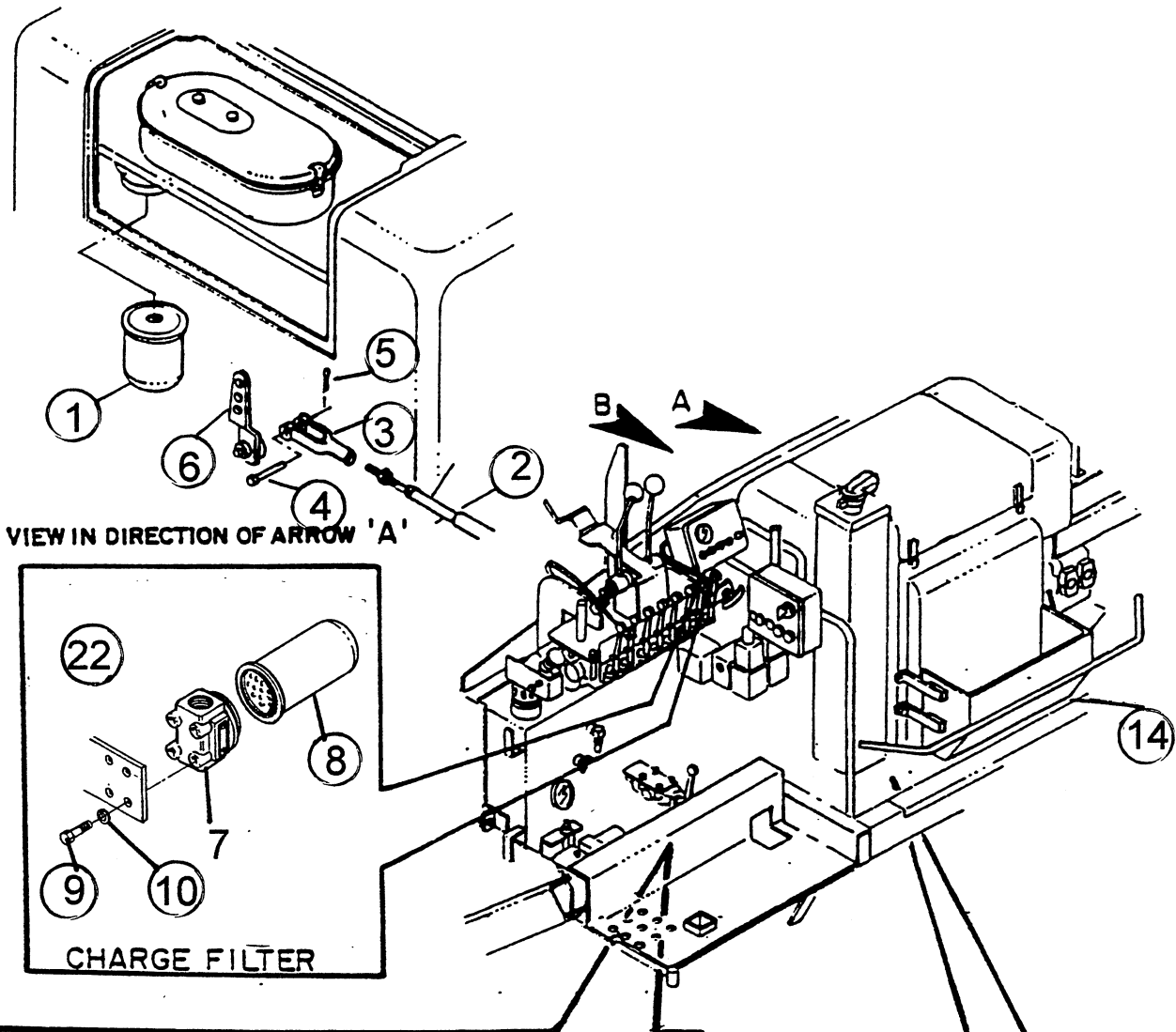

FILTER ASSEMBLY & ACCESSORIES HATZ *LeeBoy*

ITEM NO.	PART NO.	DESCRIPTION	QTY.
1	310080	ELEMENT, FUEL FILTER (HATZ DIESEL)	1
2	920161	CABLE, THROTTLE	1
3	350050	CLEVIS, 1/4"	1
4	350080	PIN, CLEVIS (1/4)	1
5	960019	PIN, COTTER (1/4)	1
6	320120	LEVER; THROTTLE *	1
7	290010	HEAD, CHARGE / RETURN FILTER *	1
8	290030	ELEMENT, CHARGE / RETURN FILTER	1
9	290032	BOLT, 3/8X1"	4
10	290034	WASHER, 3/8"	4
11	320140	ENGINE MOUNT;HATZ	4
12	320142	WASHER; LOCK (METRIC) *	4
13	320144	BOLT, 3/8X1"	4
14	320112	HEAT SHIELD	1
15			
16	900075	LINKAGE *	2
17	900060	ARM, AUTO. CONVEYOR SWITCH	2
18	900076	SCREWS *	4
19	900050	MIRCO SWITCH, AUTO. CONVEYORS	2
20			
21	900079	PIN; COTTER *	2
22	290025	HYDRAULIC FILTER, COMPLETE ASSEMBLY	1

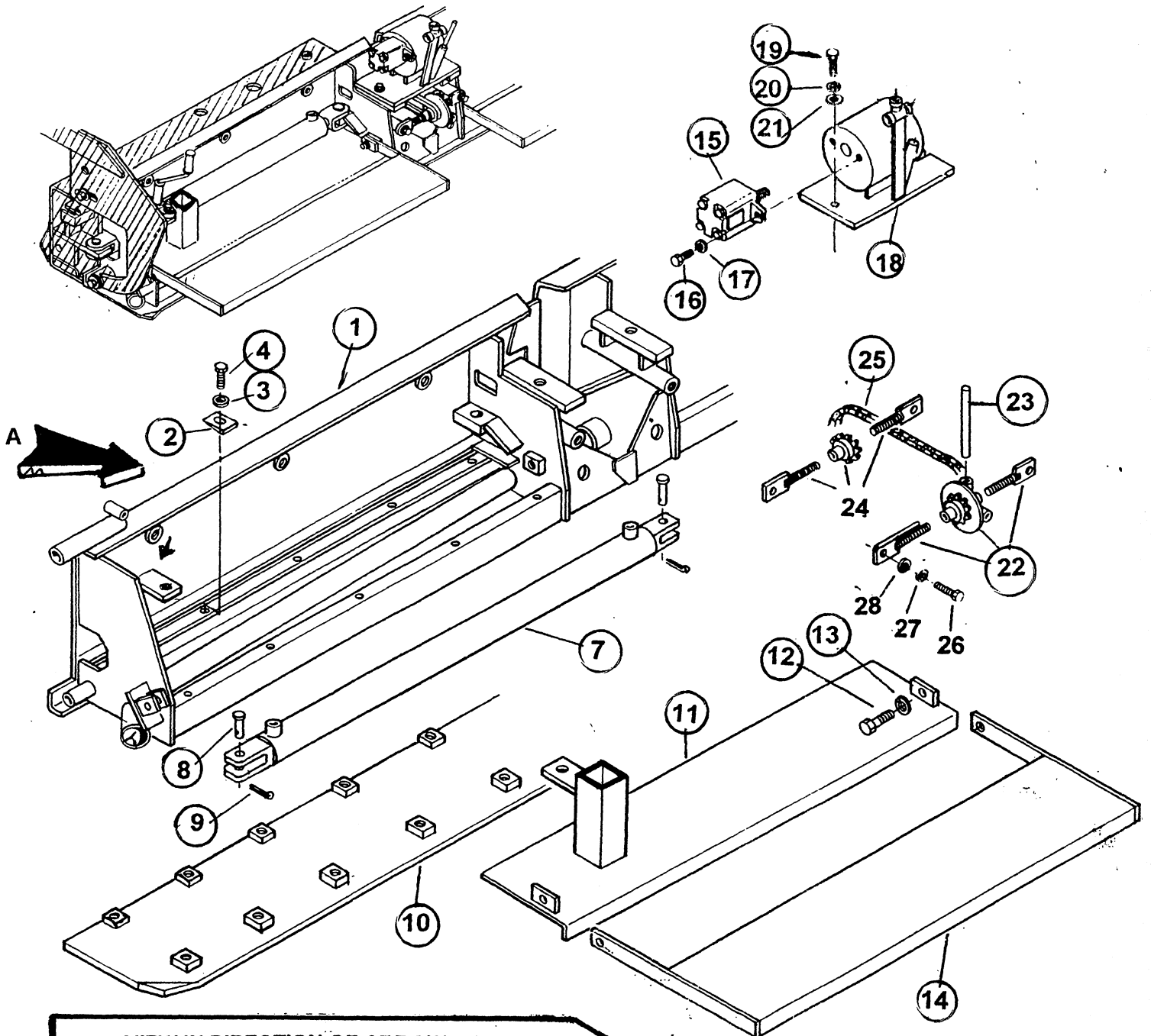

VIEW IN DIRECTION OF ARROW 'A'

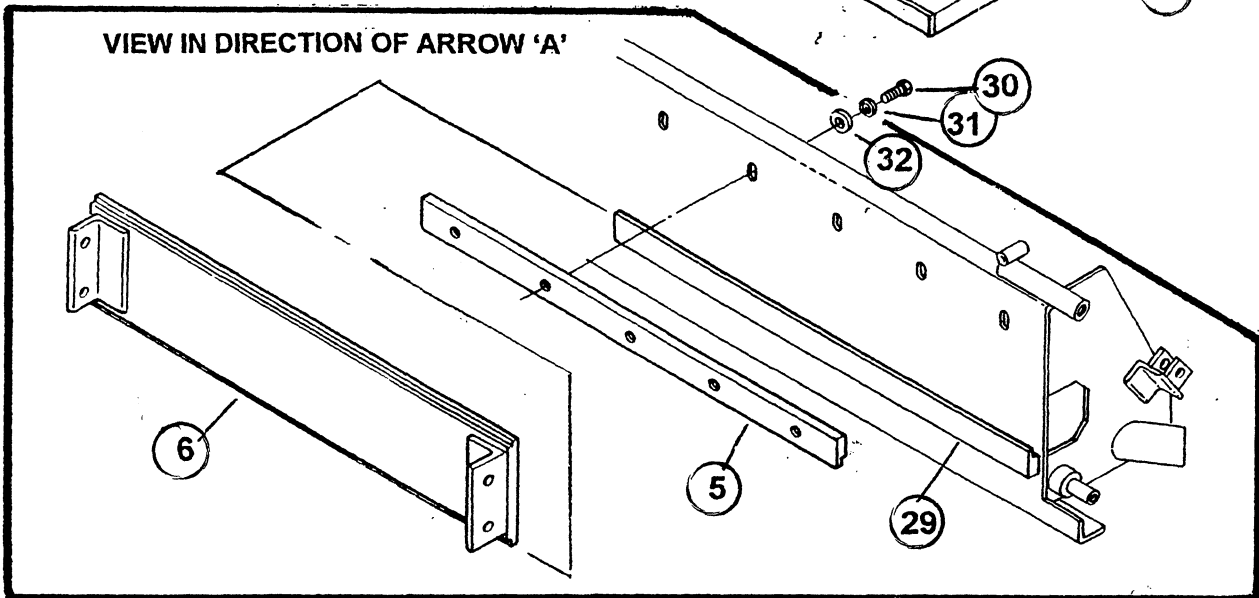

EXTENDABLE SCREED ASSEMBLY REAR



ITEM NO.	PART NO.	DESCRIPTION	QTY.
	851596	BB SCREED COMPLETE [1000C]	1
1	851597	BASE; SCREED BB	1
2	851205	WASHER; WEDGE *	20
3		BOLT, HEX 3/8"x3/4"	20
4		WASHER, LOCK 3/8"	20
5	851298	TOP GUIDE FOR SLIDE 8500	2
6	851552	8 EXTENSION MAIN SLIDE BB/DD	2
7	870140	HYD. CYL., SCREED EXT. *	2
8	240030	PIN, HYDRAULIC CYLINDER	2
9	870307	CLIPS; (FOR PINS) *	2
10	851598	BB WEARPLATE MAIN SCREED	1
11	851599	BB SCREED LID L OR R SPECIFY	2
12		BOLT, 7/16"	2
13		WASHER, LOCK	2
14	851554	WALKBOARD; 36X9 DD SCREED	2
15	870232	VIBRATOR ASSY., SCREED	1
16		BOLT, 7/16"	2
17		WASHER, LOCK 7/16"	2
18	870232	VIBRATOR ASSY., SCREED	1
19		BOLT, 5/8"x1 1/4"	2
20		WASHER, LOCK 5/8"	2
21		WASHER, FLAT 5/8"	2
22	870182	REAR TURNBUCKLE, CROWN & VALLEY *	1
23	851195	HANDLE; CRANK *	1
24	870172	FRONT TURNBUCKLE, CROWN & VALLEY *	1
25	870190	CHAIN, CROWN & VALLEY	1
26		BOLT, 5/8"x1 1/4"	2
27		WASHER, LOCK 5/8"	2
28		WASHER, FLAT 5/8"	2
29	851299	LOWER GUIDE FOR SLIDE	2

EXTENDABLE SCREED ASSEMBLY



ITEM NO.	PART NO.	DESCRIPTION	QTY.
30		BOLT, 1/2"x1 1/4"	10
31		LOCK WASHER, 1/2"	10
32		FLAT WASHER, HEAVY 1/2"	10
33	870312	UNIVERSAL SEAL KIT, 2 1/2" HYD. CYL. *	1



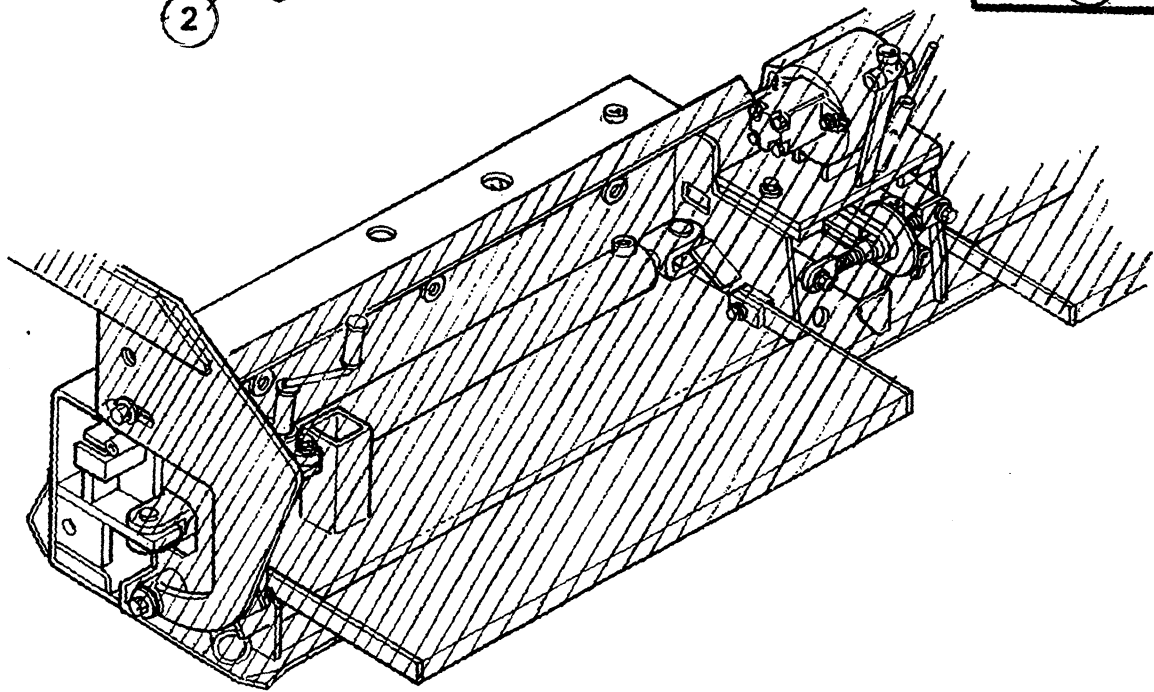
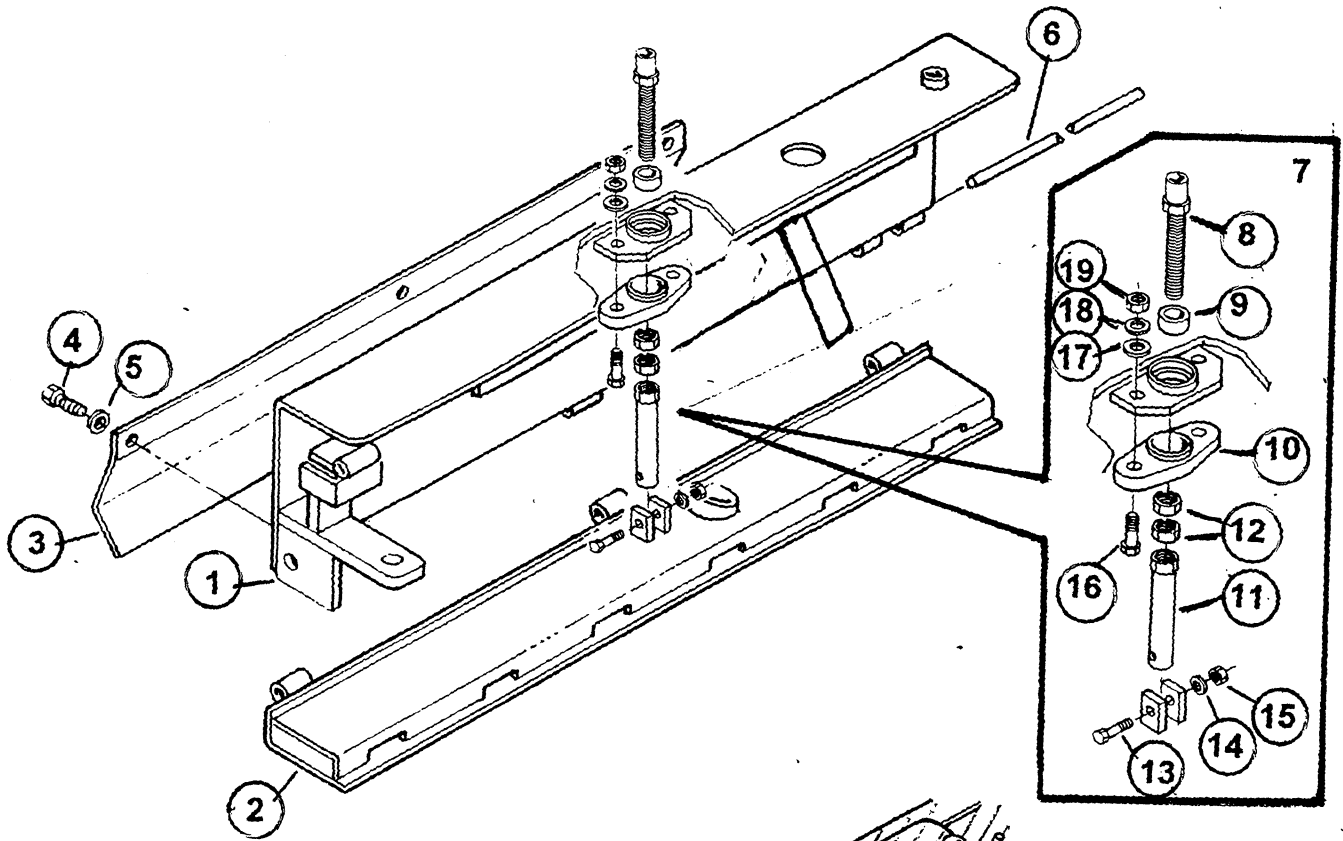

BB EXTENSION- SCREED ASSEMBLY



ITEM NO.	PART NO.	DESCRIPTION	QTY.
1	851600	EXTENSION; LEFT BB COMPLETE	1
1	851601	BB SCREED EXTENSION [RIGHT]	1
2	851602	SCREED, LOWER EXT. (SPECIFY LH. OR RH.)	1
3	851180	GUARD, EXT. (SPECIFY LH. OR RH.)	1
4		BOLT, 3/8"x1"	3
5		WASHER, LOCK 3/8"	3
6			
*7	851603	BB EXTENSION SCREW	1
8	851603	BB EXTENSION SCREW	1
9	851604	BUSHING FLANGE BEARING 1X3/4	1
10	870030	BEARING, SCREED FLIGHT SCREW*	1
11	851603	BB EXTENSION SCREW	1
12		NUT, JAM 3/4"	2
13	870279	BOLTS; SHOULDER *	2
14		WASHER, LOCK 3/8"	2
15		NUT, 3/8 LOCK	2
16		BOLT, 7/16"x2"	2
17		WASHER, FLAT 7/16"x2"	2
18		WASHER, LOCK 7/16"	2
19		NUT, 7/16"	2
*7		Comes complete with items 8,11,&12	

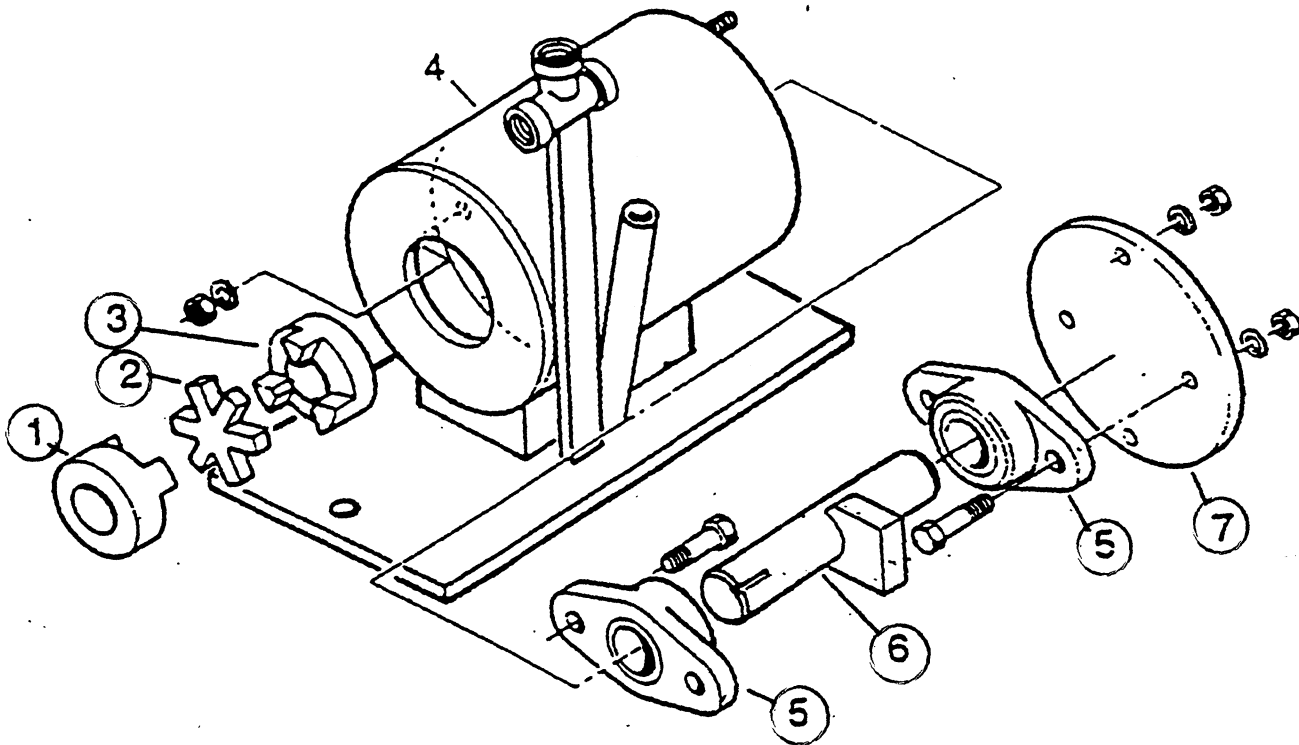

VIBRATOR ASSEMBLY



ITEM NO.	PART NO.	DESCRIPTION	QTY.
1	280030	COUPLING HALF, TACK PUMP MOTOR	1
2	280040	INSERT, 3-JAW COUPLING	1
3	880030	COUPLING HALF, 1" (VIBRATOR SHAFT)	1
4	880042	HOUSING; VIBRATOR ECCENTRIC *	1
5	250150	BEARING, CONVEYOR PULLEY/ VIBRATOR SHAFT	2
6	880062	SHAFT; VIBRATOR ECCENTRIC *	1
7	880071	PLATE; VIBRATOR HOUSING *	1

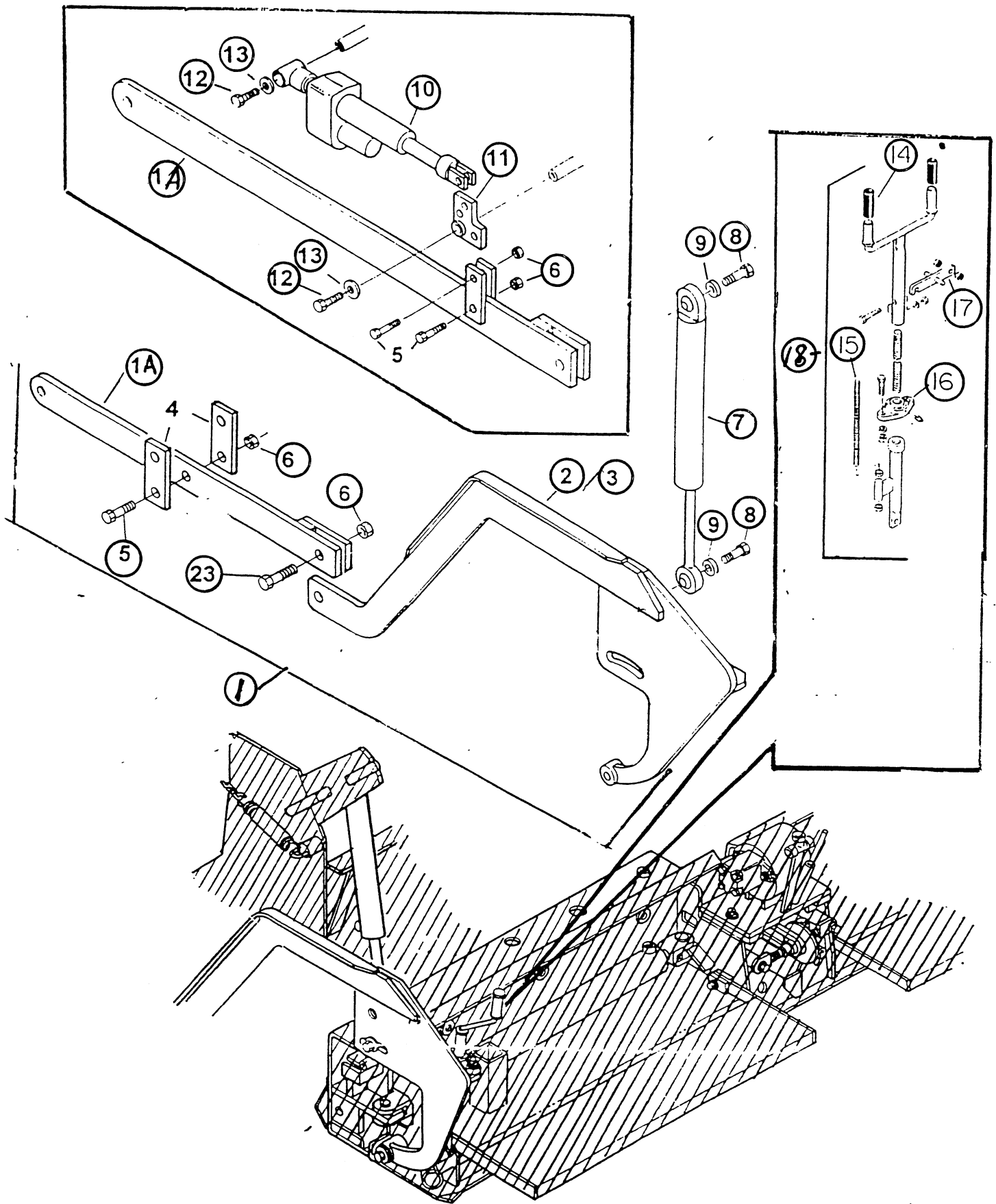

LEGEND SCREED ARMS



ITEM NO.	PART NO.	DESCRIPTION	QTY.
1	851556RA	PULL ARM, R/H ASSY. 7000 SCREED CPT.	1
	851556LA	PULL ARM, L/H ASSY. 7000 SCREED CPT.	1
2	851605LA	PULL ARM, L/H (REAR) 7000 BB SCREED	1
3	851605A	L/H OR R/H PULL ARM, FRONT	1
1A	85155A	PULL ARM, (FRONT)	2
4	851210	EARS; PIVOT *	4
5		BOLT, HEX 5/8"x2"	2
6		NUT, 5/8"x2"	2
7	851436	HYD. CYL., SCREED LIFT (1000C / 8000C / 8500)	2
8		BOLT, 1"x3"	2
9		WASHER, LOCK 1'	2
10	851518	6" ELECTRIC SCREW, SCREED (8000C / 8500)	2
11	851209	MOUNT; PIVOT *	2
12		BOLT, 3/8"x3/4"	2
13		WASHER, FENDER 3/8"	2
14	870276	HAND GRIP, FLIGHT / DEPTH SCREW *	2
15	851372	ROD GAUGE	2
16	870030	BEARING, SCREED FLIGHT SCREW*	2
17	851373	LOCK ARM	2
18	870042A	FLIGHT SCREW ASSY. SCREED	2
19	851484	UNIVERSAL SEAL KIT, 2" HYD. CYL.	A/R

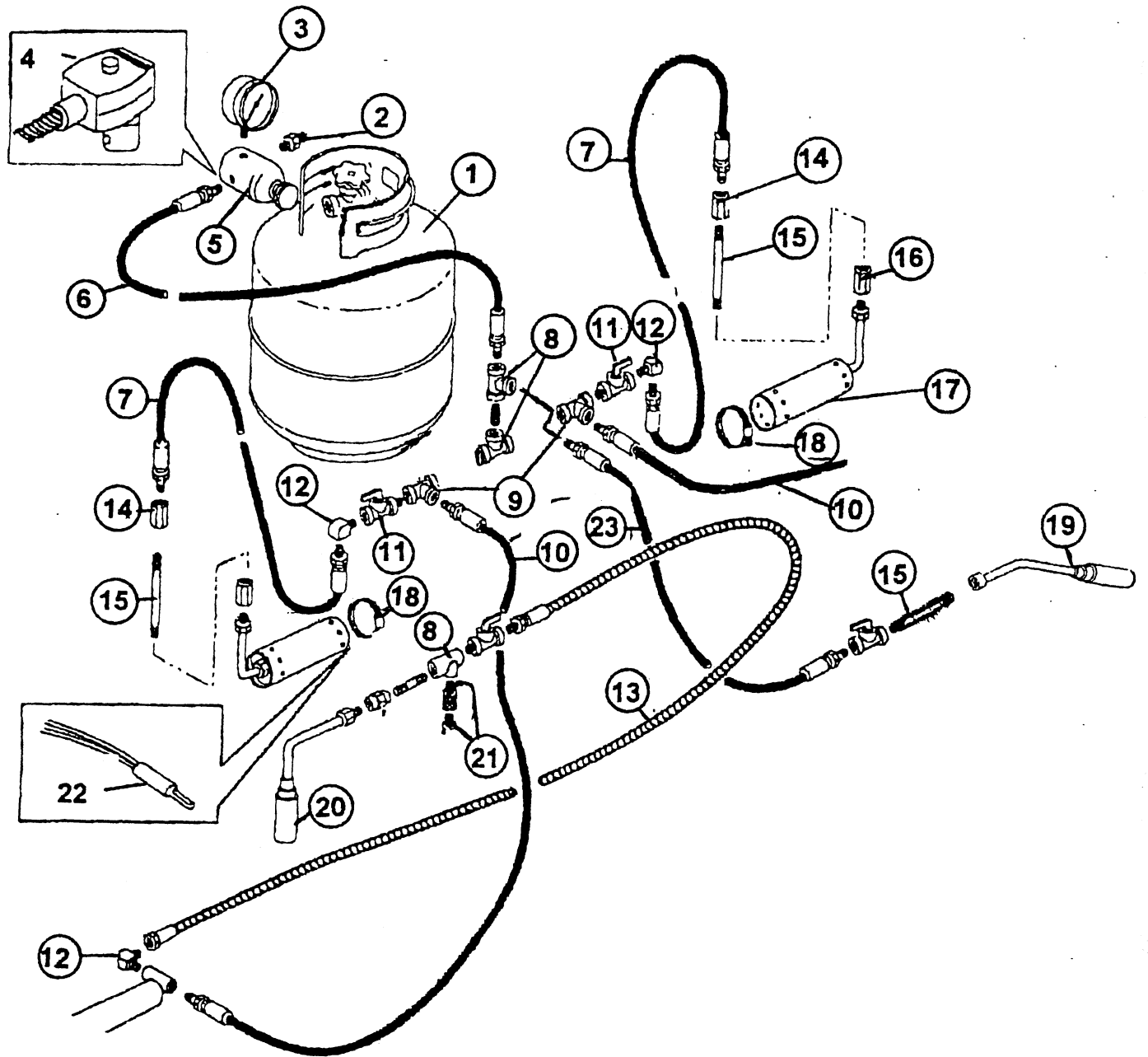

PROPANE HEATERS AND HOSES



ITEM NO.	PART NO.	DESCRIPTION	QTY.
1	230010	L.P.G. TANK, 20 LBS.	1
2	230030	ADAPTER;P.O.L.	1
3	230110	GUAGE, L.P.G. PRESS.	1
4	230300	SOLENOID VALVE, 12 VOLT L.P.G.	OPT.
5	230100	REGULATOR W / GUAGE, L.P.G.	1
6	230032	HOSE, L.P.G. REGULATOR TO TEE (7000/8000)	1
7	230034	HOSE, SCREED BURNER	2
8	230080	TEE, 1/4" PIPE	2
9	230081	TEE, 1/4" STREET	2
10	230038	HOSE, L.P.G. TEE TO SCREED EXTENSION	2
11	230070	VALVE, SELECTOR (CUTOFF)	5
12	230069	ADAPTER, HOSE TO PIPE(90 DEGREES)	3
13	851225	HOSE, SCREED EXTENSION BURNER *	2
14	230170	COUPLING, 1/4" PIPE	3
15	230999	PIPE NIPPLE, 1/4" X 6" *	3
16	230170	COUPLING, 1/4" PIPE	3
17	910025	BURNER, SCREED EXTENSION *	2
18	230240	HOSE CLAMP, 2 1/8" (SIZE 28)	2
19	230200	BURNER NOZZLE, IGNITER	1
20	230082	BURNER NOZZLE, SCREED EXTENSION (1200)	2
21	230084	QUICK DISCONNECT CPLG.	2
22	230024	IGNITER;CERAMIC HOT SURFACE*	2
23	230036	HOSE, IGNITER BURNER	1

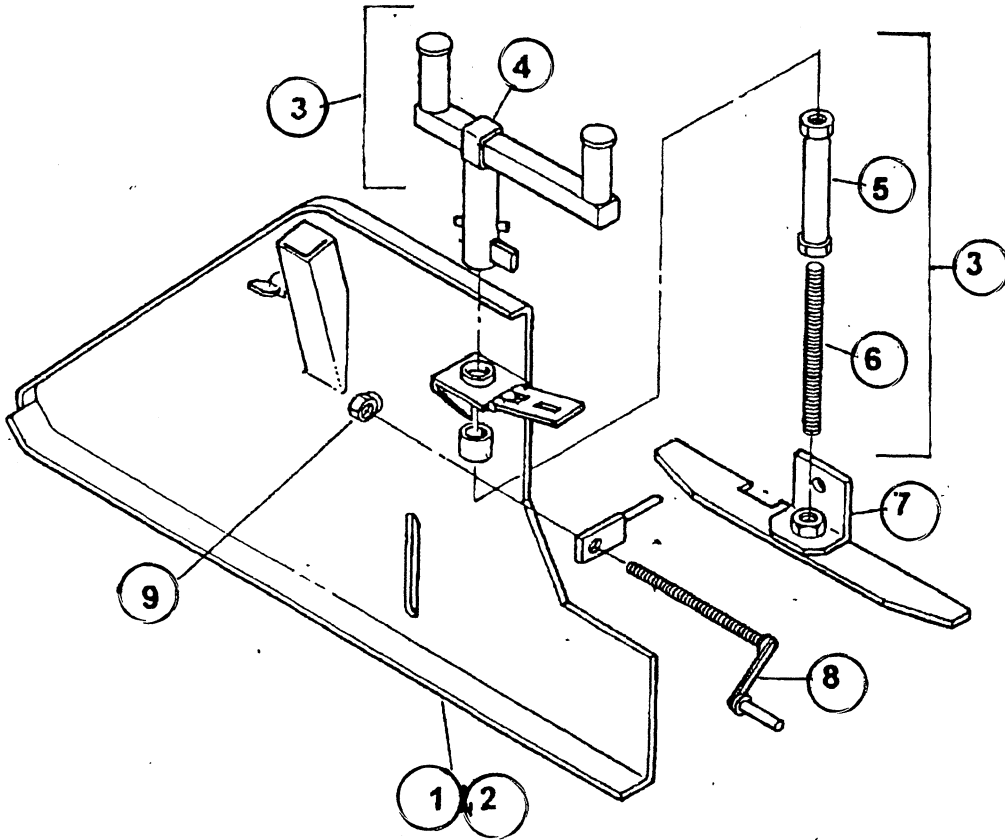
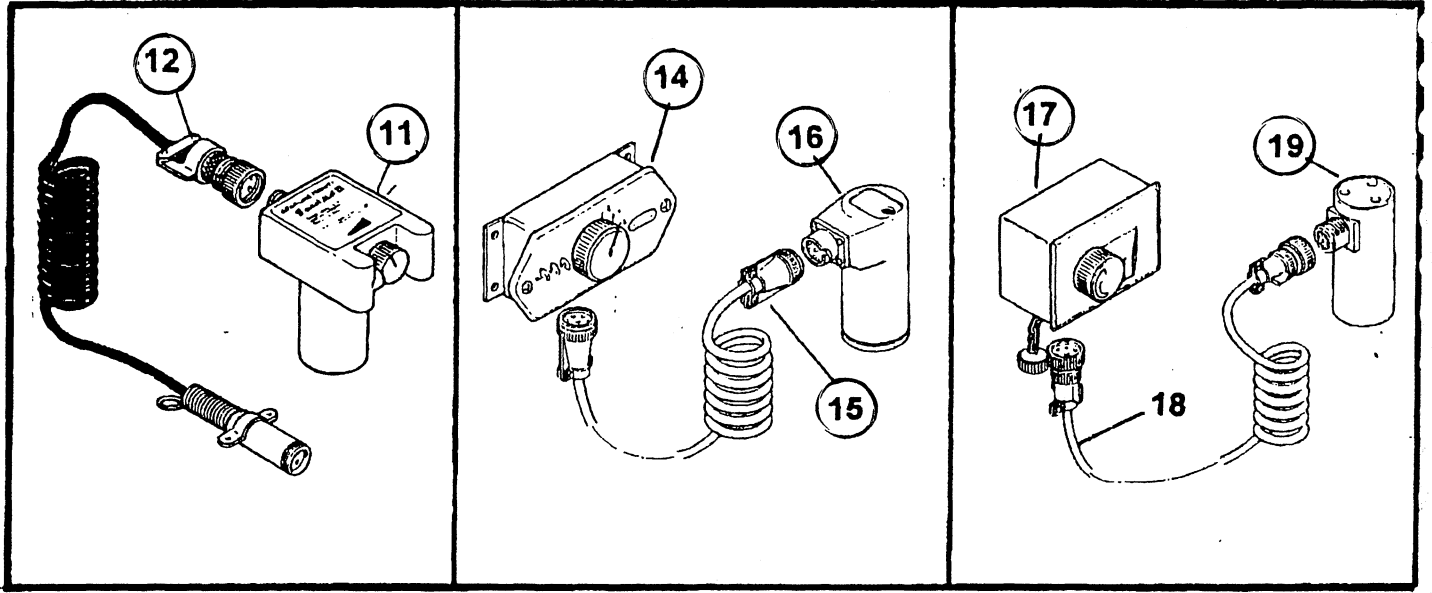

JOINTER ASSEMBLY



ITEM NO.	PART NO.	DESCRIPTION	QTY.
1	851682	JOINTER; ASSEMBLY [SHORT]	1
2	851683	JOINTER; ASSEMBLY [SHORT] R/H	1
3	890092	DEPTH SCREW ASSY., SCREED *	2
4	890092	HANDLE, DEPTH SCREW SLIDE TYPE	2
5		COMES AS # 3	
6		COMES AS # 3	
7	890132 R & L	BRACKET, DEPTH SCREW CONTROL	2
8	890081	TILT SCREW, JOINTER ASSY. *	2
9	890070	NUT *	2
10	851595	SONAMAT WIRING HARNESS (NOT SHOWN)	2
11	851592	SONIC SENSOR, AUTO-AUGER (O/S RAMSEY)	A/R
12	851593	CABLE, AUTO. AUGER SENSOR (O/S RAMSEY)	A/R
13	851594-7	KIT, SONIC AUGER	1
14	851690	CONTROL, AUTO AUGER SENSOR (N/S RAMSEY)	A/R
15	851691	CABLE, AUTO. AUGER SENSOR (N/S RAMSEY)	A/R
16	851692	SONIC SENSOR, AUTO AUGER (N/S RAMSEY)	A/R
17	851693	CONTROL, AUTO AUGER SENSOR (MOBA)	A/R
18	851694	CABLE, AUTO. AUGER SENSOR (MOBA)	A/R
19	851695	SONIC SENSOR, AUTO AUGER (N/S MOBA)	A/R

UMBRELLA

LeeBoy

ITEM NO.	PART NO.	DESCRIPTION	QTY.
1	920235	UMBRELLA (216 SQ. IN.) *	1

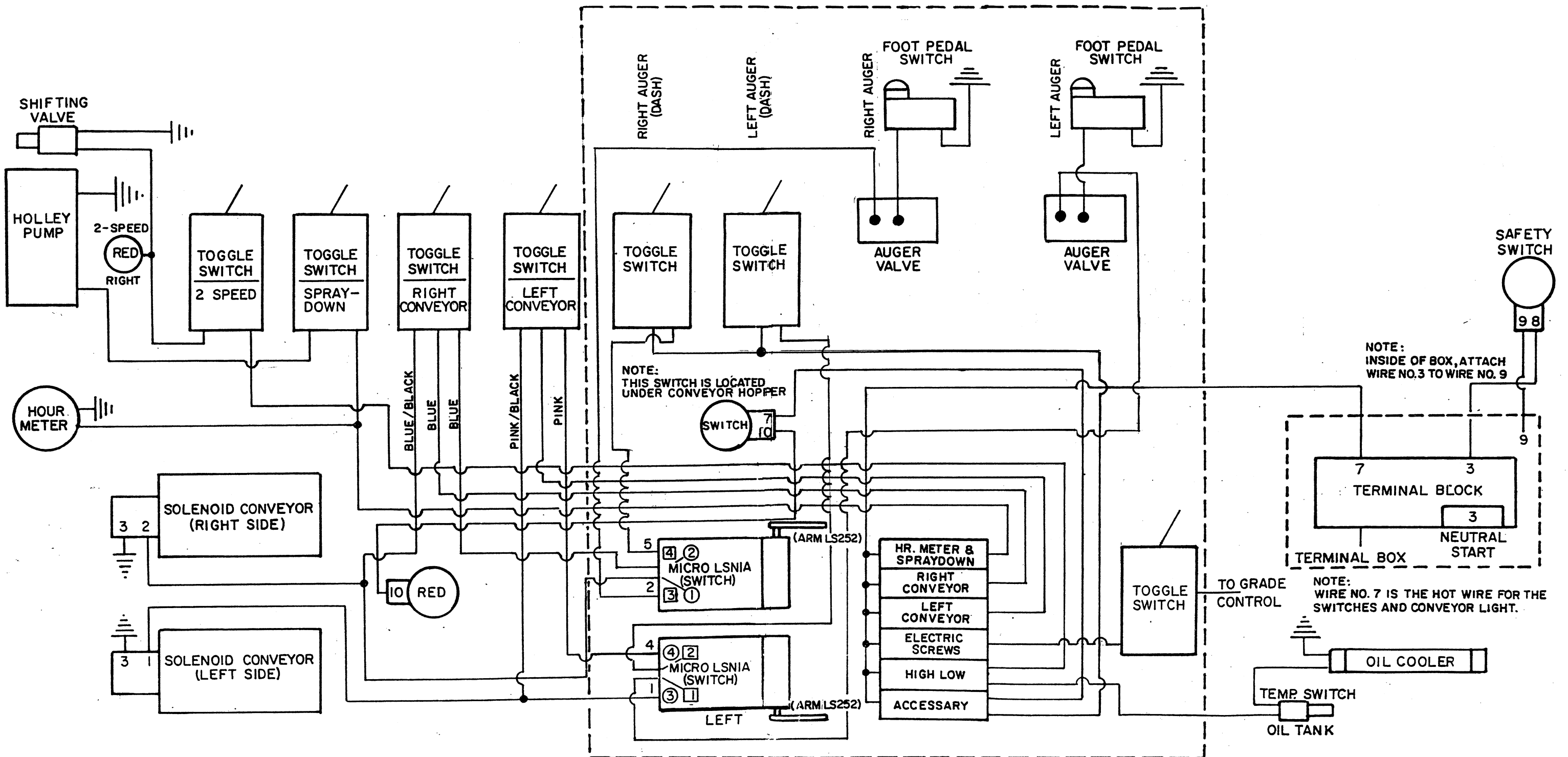

LEGEND
 ○ CONVEYOR (AUTOMATIC)
 □ AUGER (AUTOMATIC)

**ELECTRICAL DIAGRAM
 FOR 8500 PAVER**

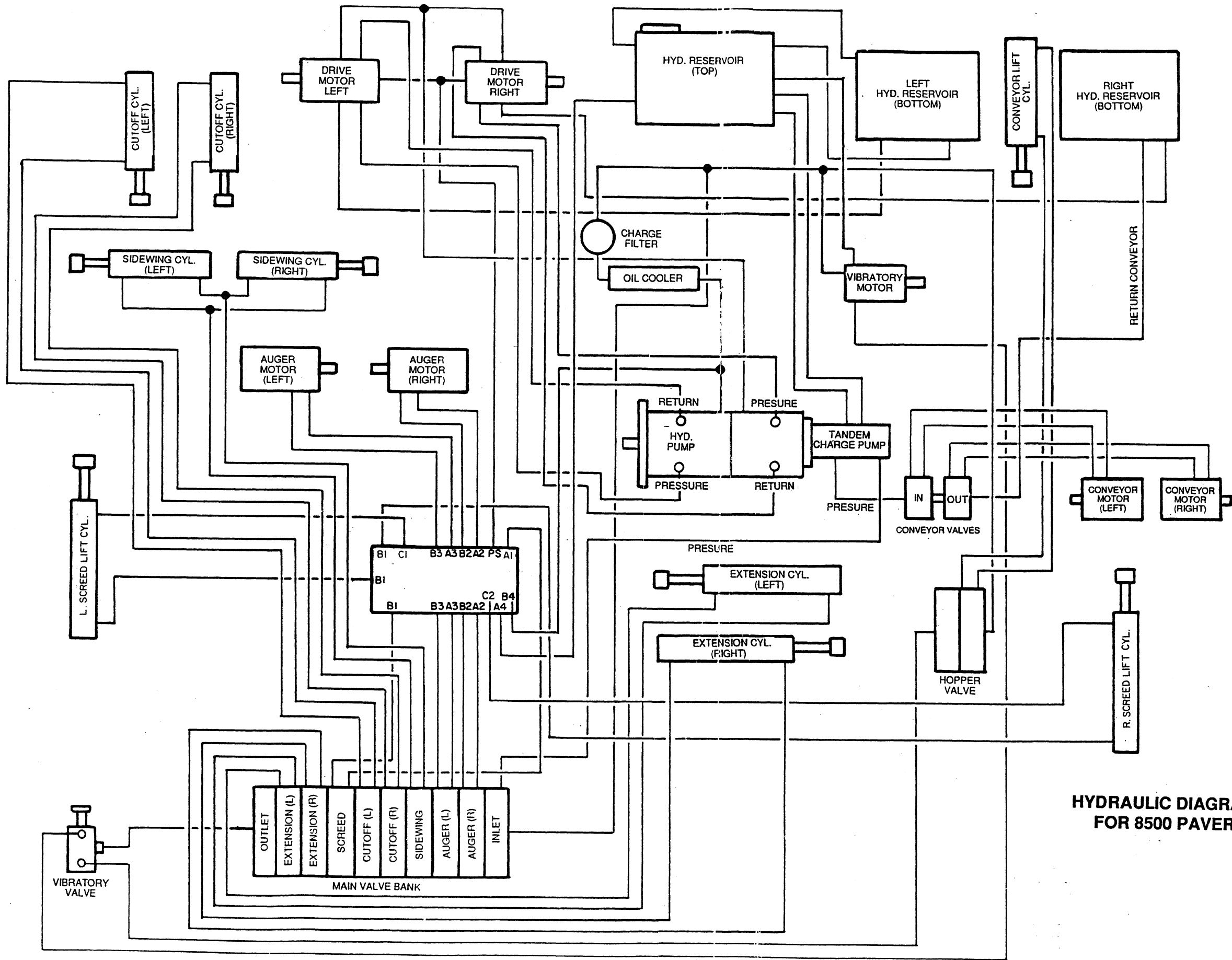

**HYDRAULIC DIAGRAM
FOR 8500 PAVER**