

# LeeBoy

## OPERATION, MAINTENANCE AND PARTS MANUAL

MODEL 8000 BH  
MANUAL NO. 8000295

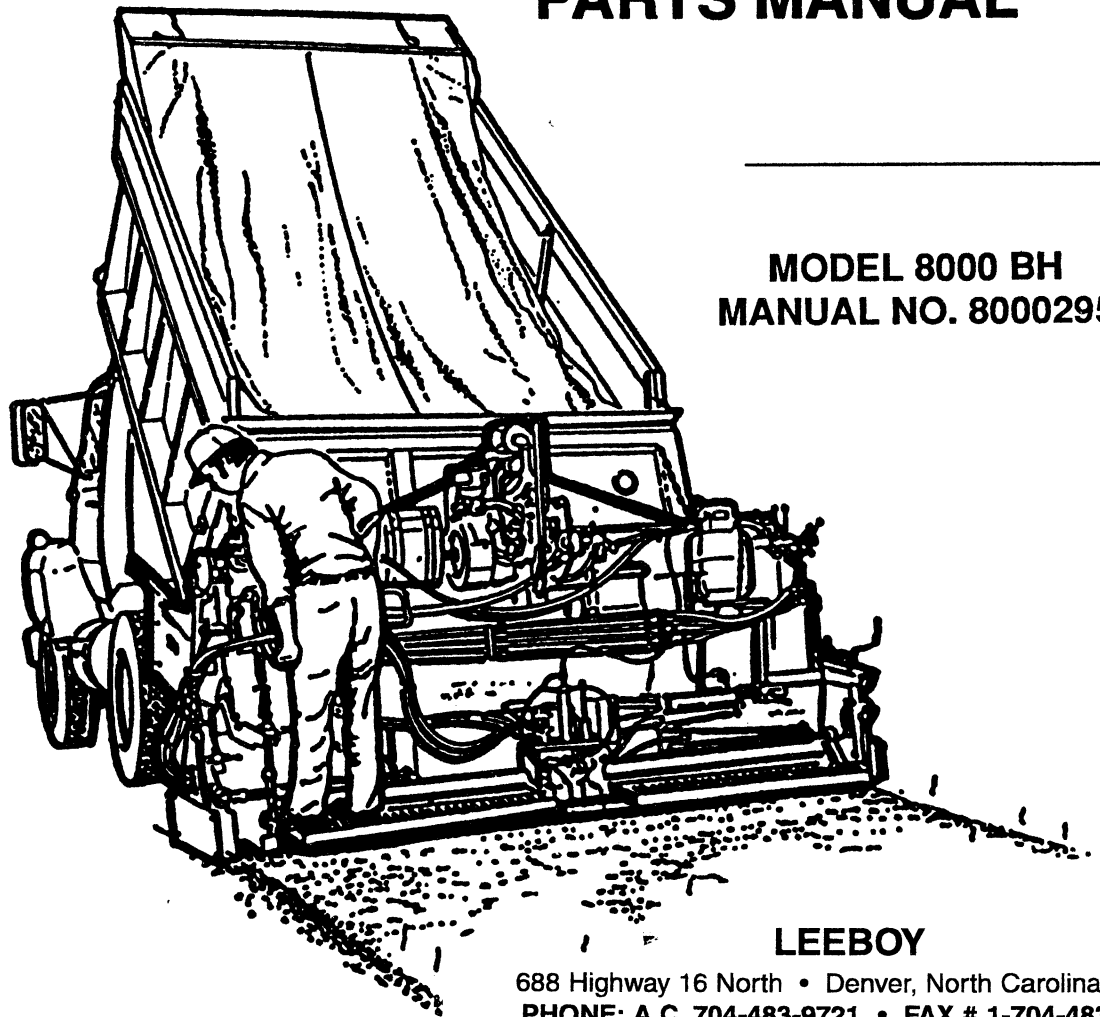

**LEEBOY**

688 Highway 16 North • Denver, North Carolina 28037  
PHONE: A.C. 704-483-9721 • FAX # 1-704-483-5802

## USER'S REFERENCE INFORMATION

DELIVER DATE _____	EQUIPMENT SERIAL NO. _____
TYPE ENGINE _____	ENGINE NO. _____
DEALER'S NAME & ADDRESS _____	EQUIPMENT HOURS _____
_____	
_____	
_____	
_____	

## SAFETY NOTICE

All danger points about the 8000B and 8000BH (High-Deck) are explained and labeled by decals to the best of our knowledge. If anyone in the field discovers anything omitted, please notify your closest dealer or factory.

## LIMITED WARRANTY

B.R. LEE INDUSTRIES, INC. warrants to the original customer that the equipment manufactured by B.R. Lee, Industries, Inc. to whom said equipment is sold as new shall be free from defects in material and workmanship for 90 days after the date of first use or delivery whichever comes first.

This warranty is limited to the following: If any part of the equipment becomes defective during the period described and is brought to an authorized B.R. Lee Industries, Inc. dealer, the dealer will, without charge, repair the part which has become defective or replace it without charge. B.R. Lee Industries, Inc. is not responsible for damaged or malfunction resulting from misuse, failure to follow recommended maintenance requirements, alteration, accident or fire.

**THIS WARRANTY IS IN LIEU OF ALL OTHER WARRANTIES OR REPRESENTATION OF ANY KIND WHATSOEVER, EXPRESSED OR IMPLIED, EXCEPT THAT OF TITLE. ACCORDINGLY, ALL IMPLIED WARRANTIES, INCLUDING ANY WARRANTY OF MERCHANTABILITY AND FITNESS FOR A PARTICULAR PURPOSE ARE HEREBY DISCLAIMED. B.R. LEE INDUSTRIES, INC. SHALL NOT BE RESPONSIBLE FOR LOSS OF TIME, LOST PROFITS, LOST USE, OR ANY OTHER CONSEQUENTIAL DAMAGES OR ANY INCIDENTAL DAMAGE.**

B.R. Lee Industries, Inc. does not authorize any person to amend or extend this limited warranty on its behalf.

# INDEX

GENERAL STATEMENT .....	1
IMPORTANT SAFETY INSTRUCTIONS .....	2
SAFETY PRECAUTIONS .....	3
OVERVIEW .....	4
SPECIFICATIONS .....	4
SAFETY PRECAUTIONS AND GENERAL INFORMATION .....	5
PRE-START INSPECTION .....	5
OPERATING SAFETY .....	5
STOPPING SAFETY .....	5
MAINTENANCE SAFETY .....	5
OPERATING CONTROLS AND DESCRIPTIONS .....	6 & 7
STARTING THE ENGINE .....	8
PRELIMINARY .....	8
DIESEL ENGINE/START-UP (QUADCO) .....	8
DIESEL ENGINE/START-UP (LEE-BOY) .....	8
STOPPING THE ENGINE .....	8
DIESEL ENGINE .....	8
PAVER DRIVING INSTRUCTIONS .....	9
TRUCK HITCH ATTACHMENT (OPTIONAL) .....	10
PAVING PREPARATION INSTRUCTIONS (LIGHTING BURNERS) .....	11
OPERATING FEEDER .....	12
OPERATION OF ELECTRIC FLIGHT SCREW .....	12
USE OF AUGER EXTENSIONS .....	12
OPERATION OF HYDRAULIC CUTOFFS .....	12A
AUTOMATIC AUGERS .....	12A
ELECTRIC SPRAYDOWN .....	12A

**\*MUST HAVE MODEL & SERIAL # TO PACK PARTS ORDER**

**INDEX**  
**(continued)**

LOADING AND UNLOADING .....	13
UNLOADING .....	13
LOADING .....	13
TIE DOWN PROCEDURE .....	14
STARTING TO PAVE .....	15
ADJUSTING CROWN CONTROL .....	18
ROUTINE MAINTENANCE .....	19
10 - HOUR OR DAILY ROUTINE MAINTENANCE .....	19
50 - HOUR OR WEEKLY ROUTINE MAINTENANCE .....	20
100 - HOUR OR MONTHLY ROUTINE MAINTENANCE .....	20
250 - HOUR OR QUARTERLY ROUTINE MAINTENANCE .....	21
500 - HOUR OR SEMI-ANNUAL ROUTINE MAINTENANCE .....	21
1000 - HOUR OR ANNUAL ROUTINE MAINTENANCE .....	21
LUBRICATION CHART .....	22
MAINTENANCE ADJUSTMENTS .....	23
RAISE FEEDERS .....	23
LOWER FEEDER .....	24
FEEDER FLIGHT CHAIN ADJUSTMENT .....	24
TRACK ADJUSTMENTS .....	25
FEEDER DRIVE CHAIN .....	25
AUGER DRIVE CHAIN .....	25
TROUBLE SHOOTING GUIDE 8000 .....	26 & 27
ELECTRICAL DIAGRAM .....	28
HYDRAULIC DIAGRAM 8000B AND 8000BH .....	29
PARTS LIST .....	30

**\*MUST HAVE MODEL & SERIAL # TO PACK PARTS ORDER**

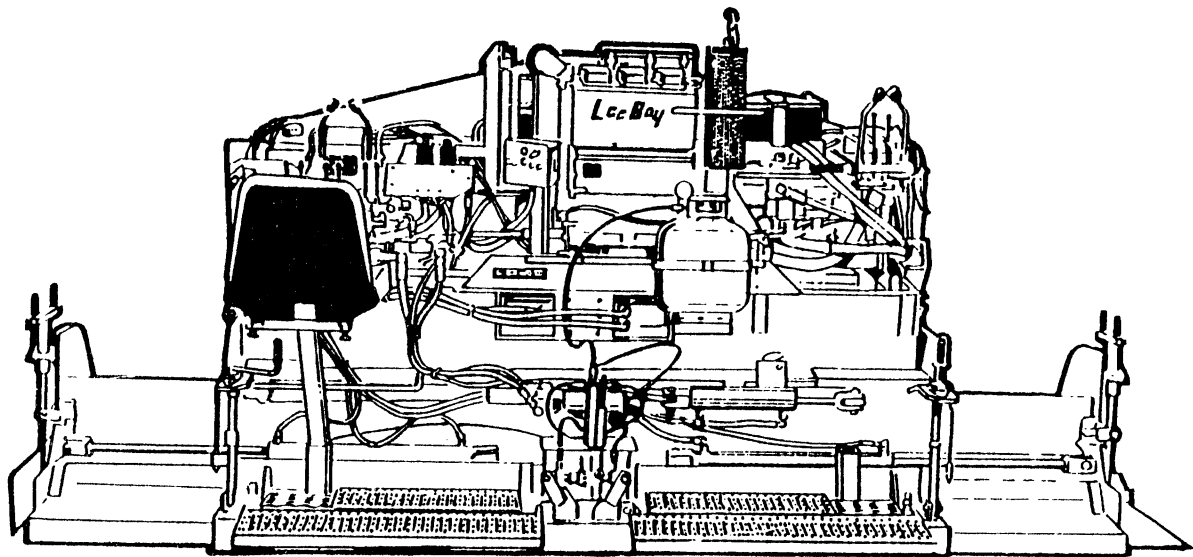

**MODEL  
8000 B /  
8000 BH  
ASPHALT PAVER  
OPERATORS,  
MAINTENANCE  
AND PARTS MANUAL**

This manual should be used with all related supplemental books, engine and transmission manuals, and parts books. Related Service Bulletins should be reviewed to provide information regarding some of the recent changes.

If any questions arise concerning this publication or others, contact your local Lee-Boy Distributor for the latest available information.

Contents of this manual are based on information in effect at the time of publication and are subject to change without notice.

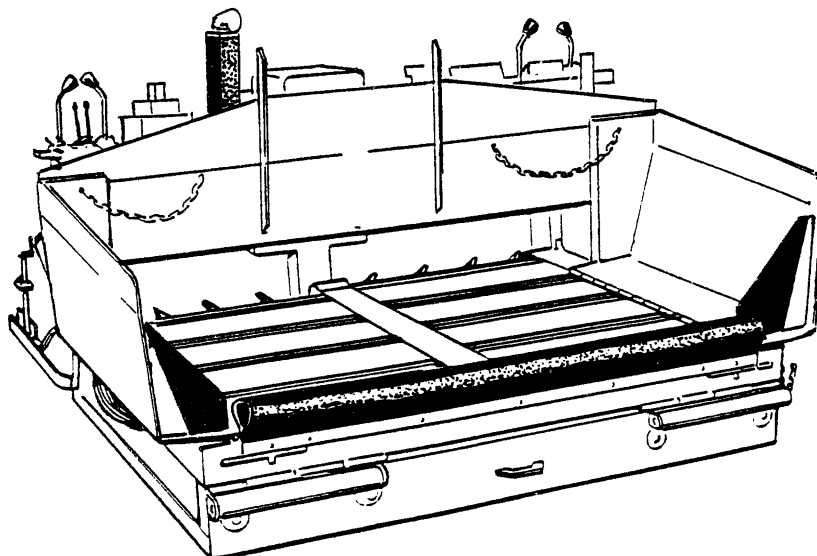

# IMPORTANT SAFETY INSTRUCTIONS

This manual provides important information to familiarize you with safer operating and maintenance procedures. Even though you may be familiar with similar equipment you **MUST** read and understand this manual before operating this unit.

Safety is everyone's business and is one of your primary concerns. Knowing the guidelines covered in the following paragraphs and in Section 1 will help provide for your safety, for the safety of those around you, and for the paver's proper operation.

LOOK FOR THESE SYMBOLS WHICH POINT OUT ITEMS OF EXTREME IMPORTANCE TO YOU AND YOUR CO-WORKERS SAFETY. READ AND UNDERSTAND THOROUGHLY. HEED THE WARNING AND FOLLOW THE INSTRUCTIONS.

## **! DANGER !**

**YOU MUST FOLLOW ALL DANGER SAFETY NOTES. IF YOU DO NOT FOLLOW THE INSTRUCTIONS, YOUR MISTAKE MIGHT LIKELY RESULT IN VERY SERIOUS INJURY OR DEATH.**

---

## **! WARNING !**

**WARNING** safety notes must **ALSO** be followed. Your mistake might result in **SERIOUS INJURY** to yourself or others.

---

## **! CAUTION !**

**CAUTION** safety notes are **ALSO** very important. They point out to you where your mistakes could cause **PHYSICAL HARM** to you or others, or damage to the machine.

---

# SAFETY PRECAUTIONS

If your paver has been repainted, it is extremely important that all the decals referring to cautions, warnings and danger be replaced in their proper locations. The illustrations on this page will aid you in determining the proper locations, however for additional help, you should refer to the part listing in the parts section of this manual and note the description column. Under this column a description on location is provided for each decal. If you still need more explicit instructions contact your dealer.

**! IMPORTANT ! ! IMPORTANT !**

It is the responsibility of the owner and operator to make sure that all decals are readable and located on paver as designated by manufacturer.

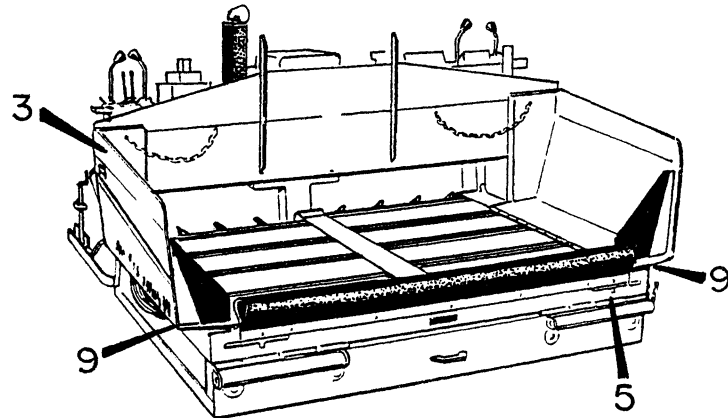
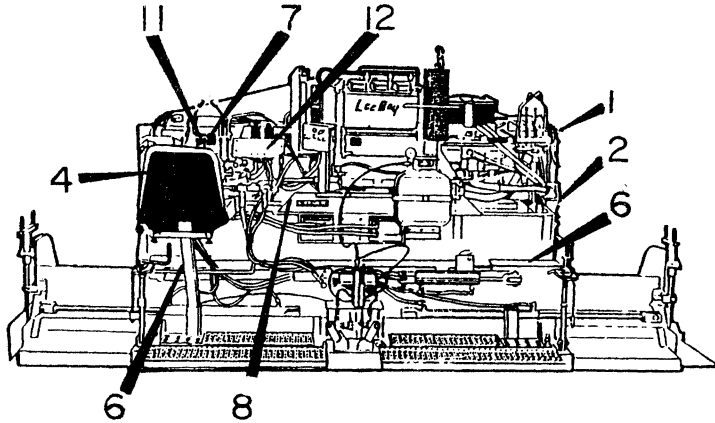

**DANGER**  
DO NOT FILL FUEL TANK WHILE ENGINE IS RUNNING OR SCREED IS BEING HEATED

1

**WARNING**  
**DO NOT USE**  
ELECTRIC SPRAY SYSTEM WHEN BURNERS ARE IN USE

2

**DANGER**  
**PINCH POINT**  
**CAUTION**  
DO NOT SPRAY FUEL OIL ON TIRES. WHEN SIDE WINGS ARE FOLDED OUT, DO NOT OPERATE HYDRAULICALLY. (ALWAYS SECURE SIDE WINGS BEFORE OPERATING)

3

**WARNING**  
HYDRAULIC OIL **ONLY**  
KEEP CLEAN

4

**SAFETY**  
**LIP PROP**

5

**DANGER**  
**PINCH POINT**

6

DO NOT OPERATE OR TOW THIS MACHINE WITHOUT FIRST FULLY UNDERSTANDING THE CONTENTS OF THE OPERATORS MANUAL.

7

**DANGER**  
Keep Hands & Clothing Clear of Augers & Conveyors

8

**DANGER**  
Always Keep Guidebar Latched While in Transit (Keep All Adjustments Tight)

9

**DANGER... DO NOT ATTEMPT TO SHIFT HIGH AN LOW GEAR LEVER UNLESS MACHINE IS SITTING LEVEL BY OPERATOR'S EYE.**

(Transmission Only)  
Shifter Handle

10

**WARNING**  
ALWAYS FOLD SIDEWINGS ON HOPPER OUT BEFORE RAISING CONVEYOR.

11

**IMPORTANT**  
WHEN CHANGING GEARS MOVE DRIVE LEVERS FORWARD AND REVERSE GENTLY, WHILE APPLYING ABOUT 15 LBS. PRESSURE ON SHIFTER HANDLE. THIS WILL ELIMINATE TRANSMISSION DAMAGE.

(Transmission Only)  
Shifter Bracket

12



## SAFETY PRECAUTIONS AND GENERAL INFORMATION

### PRE-START INSPECTION

INSPECT machine. Have any malfunctioning, broken or missing parts corrected or replaced before using. Hydraulic hoses should be checked daily for wear and leaks. Replace if damaged.

CHECK that all the instruction and safety labels are in place and readable. These are as important as any other equipment on the machine.

READ and FOLLOW all instruction decals.

WEAR OSHA required safety equipment when running the paver.

FILL the fuel tank with the engine off. Never fill near an open flame, when smoking or when screed heat is on.

CLEAR auger & feeders before starting engine. And make sure all covers and guards are in place.

### OPERATING SAFETY

ALWAYS make sure no person or object is in your line of travel BEFORE starting.

WORK slowly in tight areas.

DO NOT run engine in a closed building for long periods of time. NEVER spray fuel oil on or near screed while it is being heated.

AVOID steep hills if possible

DO NOT shift transmissions on steep grades.

ALWAYS look BEFORE changing your direction of travel.

DO NOT pave in high speed range, use it only for travel. Do not counter rotate machine in high range.

NEVER open a valve to burner unless a flame is present. Heat screed for no more than 5 minutes. Make sure all valves are closed after burner is turned off.

AVOID leaving engine running without operator present.

### STOPPING SAFETY

ALWAYS park the paver on solid, level ground, in low range. IF this is not possible, always park the paver at a right angle to the slope, lower screed when parked.

USE proper flags, barriers and warning devices especially when parking in areas of traffic.

### MAINTENANCE SAFETY

AVOID working on the paver with the engine running.

NEVER fill the fuel tank with the engine running.

DO NOT change the engine governor settings.

ALWAYS replace damaged or lost decals.

DISCONNECT battery cables when working on the electrical system, or when welding on the unit.

IF battery needs a charge be sure battery charger is off when making connections.

BE SURE the correct battery polarity is observed (negative (-) to negative (-) and positive (+) to positive (+)) when connecting a battery charger or jumper cable.

**! DANGER !**

**NEVER WORK UNDER HOPPER WITHOUT PLACING SAFETY PROP IN POSITION. SEE FIGURE 1**

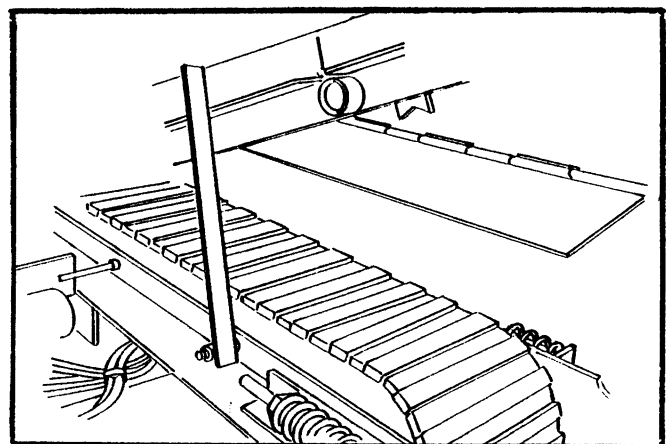
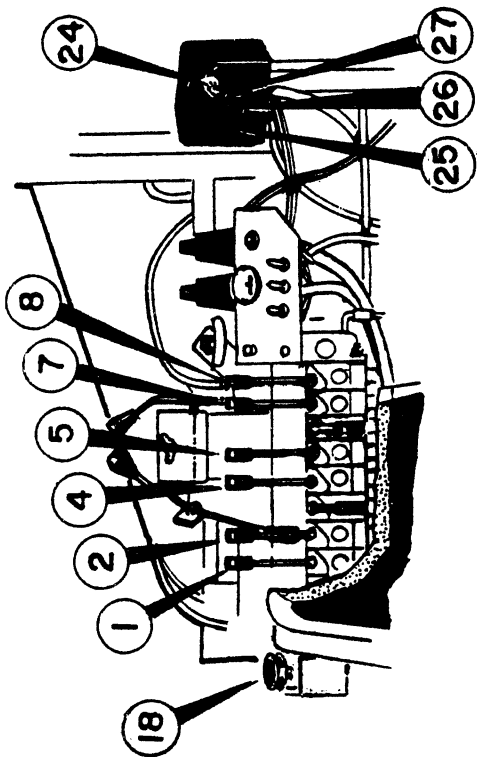
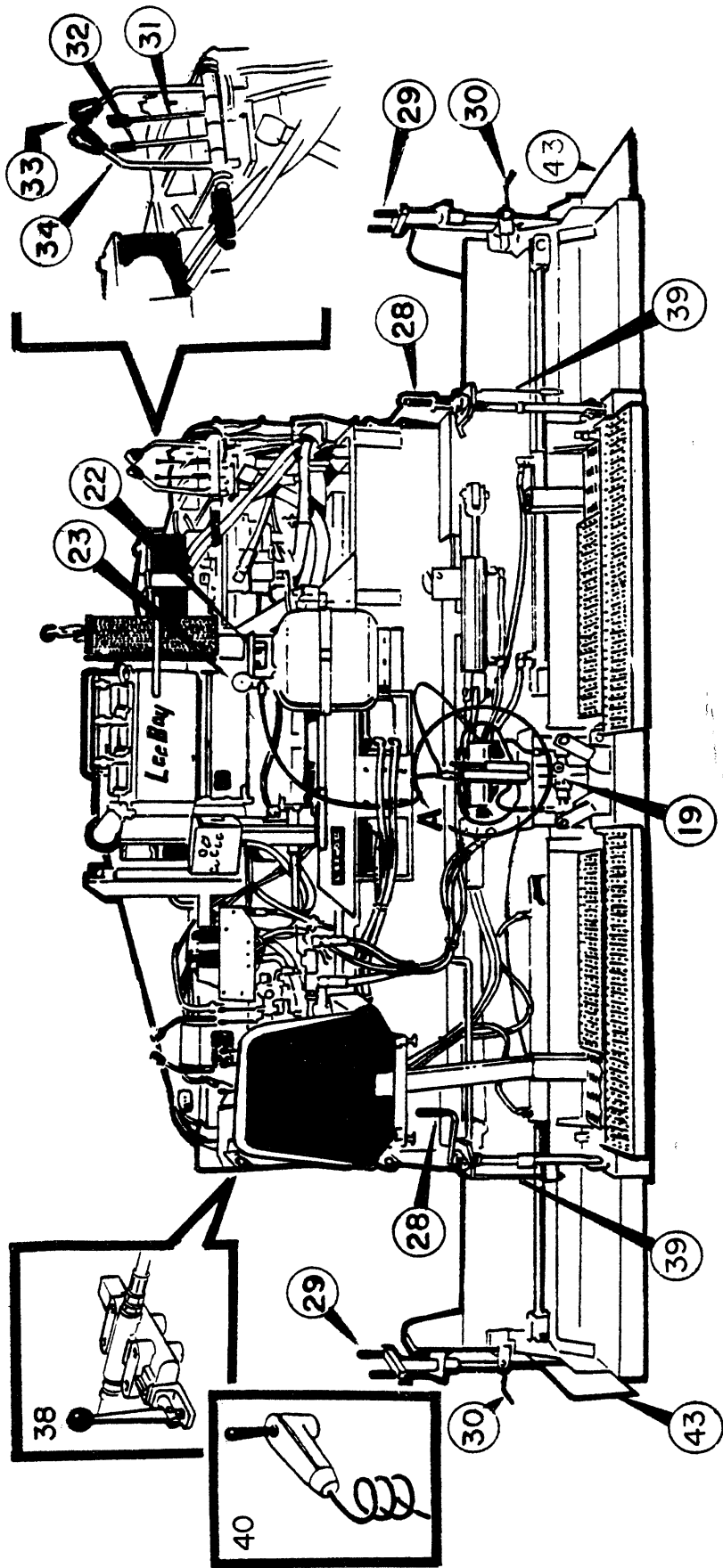
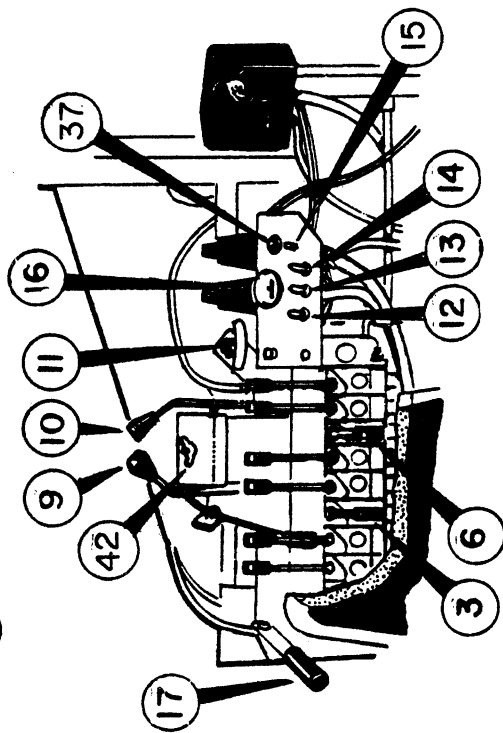

FIGURE 1



Auxiliary View of Main Control Group  
with Vibrator Valve, Item 18



Auxiliary View of Main Control Group  
with High and Low Gear, Handle, Item 17

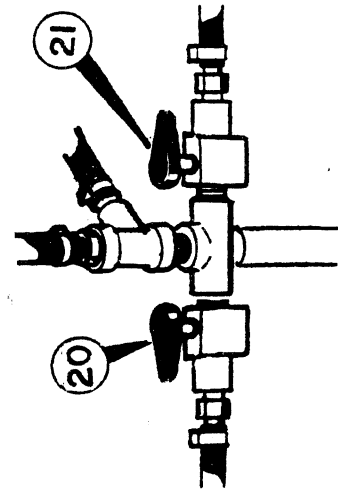

VIEW IN CIRCLE "A"

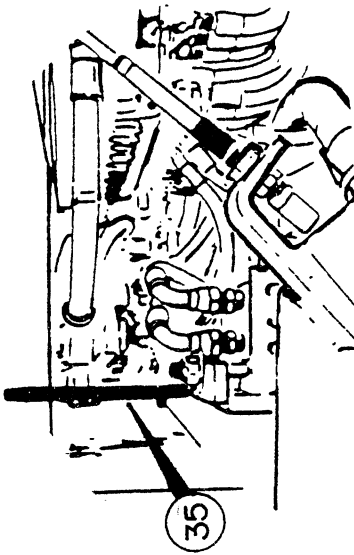

8000 B

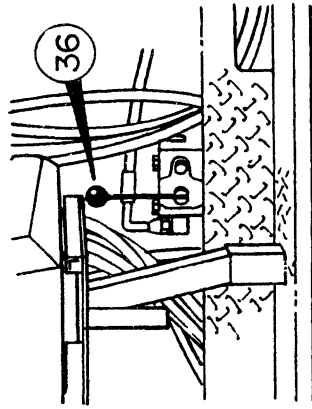

**OPERATING CONTROLS AND DESCRIPTION**

CONTROLS	DESCRIPTION
1. Screed Extension, Left	Extends and Retracts Left Screed Extend
2. Screed Extension, Right	Extends and Retracts Right Screed Extend
3. Screed Lift	Raises and Lowers Screed
4. Cut Off, Left	Stops Asphalt Flow Left Auger
5. Cut Off, Right	Stops Asphalt Flow Under Right Auger
6. Hopper Side Panel	Changes Angle of Hopper Side Panel
7. Auger, Left	Distributes Asphalt to Left Screed Extension
8. Auger, Right	Distributes Asphalt to Right Screed Extension
9. Drive, Left	Forward and Rearward Drive of Left Track
10. Drive, Right	Forward and Rearward Drive of Right Track
11. Throttle	Controls Engine Speed
12. Feeder, Left	Feeds Asphalt to Screed, Left Side
13. Feeder, Right	Feeds Asphalt to Screed, Right Side
14. Spray Down	Used for Cleaning
15. High and Low Gear, Toggle	Selects High and Low Gear (high travel, low paving)
16. Hour Meter	Indicates Hours on Machine
17. High and Low Gear, Handle	Selects High and Low Gear (high travel, low paving)
18. Vibrator	Helps Compact Asphalt
19. Crown and Valley Lever	Adjust The Crown or Valley Screed
20. Left Burner	Controls Flow of Propane to Left Screed Burner
21. Right Burner	Controls Flow of Propane to Right Screed Burner
22. Propane Tank Main Valve	Opens and Closes Propane Line Pressure
23. Propane Tank Pressure Regulator	Regulates Propane Pressure

CONTROLS	DESCRIPTION
24. Ignition	To Start Engine
25. Oil Warning Light	Indicates Low Oil Level
26. Air Filter Warning Light	Indicates Dirty Filter
27. Battery Discharge Light	Indicates Low or No Charge
28. Thickness Control Lever	Fine Control of Material Depth
29. End Gate Control Handle	Sets End Gate to Desired Depth
30. Tilt Control Handle (joint matching shoe)	Changes Pitch of End Gate
31. Lever, Screed Ext. Right	Extends and Contracts Screed, Right
32. Lever, Auger, Right	Distributes Asphalt to Right Screed Extension
33. Right Side Drive Control, Right	Forward and Rearward Drive of Right Track
34. Right Side Drive Control, Left	Forward and Rearward Drive of Left Track
35. Feeder Lift Lever (8000B)	Lifts Feeder (See Instructions, Page 23)
36. Feeder Lift Lever (8000BH)	Lifts Feeder (See Instructions, Page 23)
37. High/Low Speed Range and Adjust Feed Chain Light	Light Is On And Does Not Flash, Paver Is In High Range
38. Truck Hitch Lever	Extends and Contracts Truck Hitch Arms
39. Screed Level Indicator	Indicates Position of Screed
40. Screed Depth Remote Switch	Raises and Lowers Screed Varies Asphalt Thickness
41. Guide Bar (Not Shown)	Alignment of Paver to Paving Area
42. Speed Lock Control	Sets Drive Levers So Paver Maintains Even Speed and True Direction
43. Joint Matcher	Helps Even Asphalt Joint

## STARTING THE ENGINE

### PRELIMINARY

Before you start the engine:

- A. Check fuel level and check lines and tank for leaks.
- B. Check crankcase oil level.

## **! CAUTION !**

**FAILURE TO MAINTAIN CORRECT OIL LEVEL IS GREATEST SINGLE CAUSE OF ENGINE FAILURES.**

- C. Check hydraulic oil level. Oil level is determined by petcock on hydraulic oil tank.
- D. Make sure steering control levers are in neutral. Squeeze handles together on safety switches so machine will crank.
- E. Refer to engine operators manual for instructions when starting engine for first time. Follow engine manufacturer's recommendations for fuel and oil. (Quadco Only)

### DIESEL ENGINE/START-UP

(Quadco Control Drive Lever, See Figure 2)

1. Open throttle full.
2. Insert key and turn clockwise to start position.
3. Position Quadco drive levels to neutral and squeeze levers together until engaging starter.
4. When engine starts and is running smooth, throttle back to idle, allow to warm up.

### DIESEL ENGINE/START-UP

(Lee-Boy Drive Levers, See Figure 3)

1. Open throttle full.
2. Insert key and turn clockwise to start position.
3. Position Lee-Boy drive levers to neutral.
4. When engine starts and is running smooth, throttle back to idle, allow to warm up.

### NOTE

For your convenience, there is an extra key inside the switch box in case the original key is lost.

4. After engine start, warm up for several minutes before moving paver. This warm up will allow hydraulic oil to warm, providing for more efficient operation. In cold weather let hydraulic oil warm to 50° or 60° before moving.

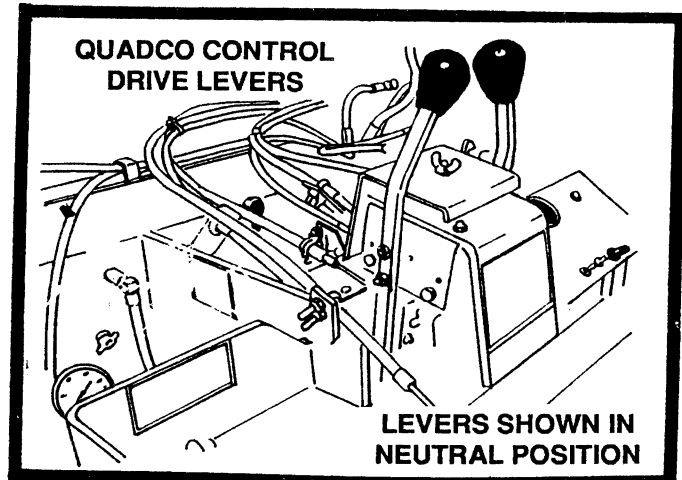

FIGURE 2

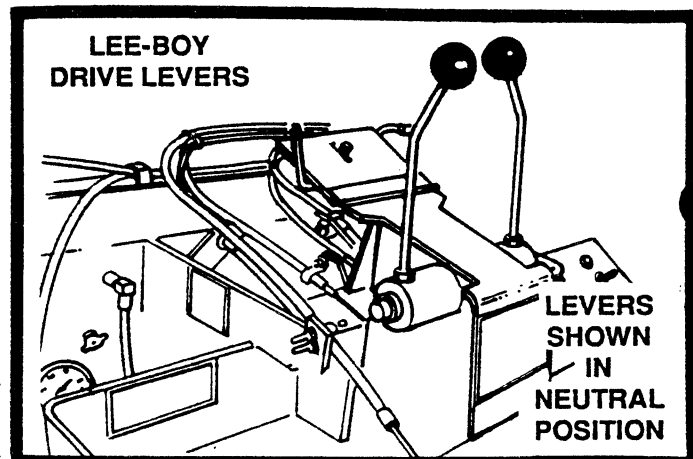

FIGURE 3

### NOTE

The use of starting additives, such as ether, is not recommended.

## STOPPING THE ENGINE

### DIESEL ENGINE

1. Throttle engine down.
2. Turn ignition key counter-clockwise (CCW) to the "off" Position and remove.
3. If for any reason the engine does not shut down when key is turned to "off". Take pin out of clevis on throttle, back of engine and push throttle control off.

## **! CAUTION !**

**DO NOT OPERATE THE STARTER LONGER THAN 30 SECONDS. IF THE ENGINE DOES NOT START, ALLOW THE STARTER TO COOL 2-3 MINUTES BEFORE TRYING AGAIN.**

## PAVER DRIVING INSTRUCTIONS

### GENERAL

The forward/reverse plus turning will require exact movement. The steering levers along with the inter-connected hydraulic components make possible the positive control necessary. The following procedures plus illustrations in figures 4.5 and 6 will provide a working knowledge of operating the paver through forward/rearward and turning requirements.

1. After the paver has been started and the motor is warmed up, paver movements may be made.
2. To drive the paver forward, push the steering levers together from the neutral position forward, likewise to drive to the rear, pull the steering levers toward the rear from the neutral position. Refer to figures 4 & 5.

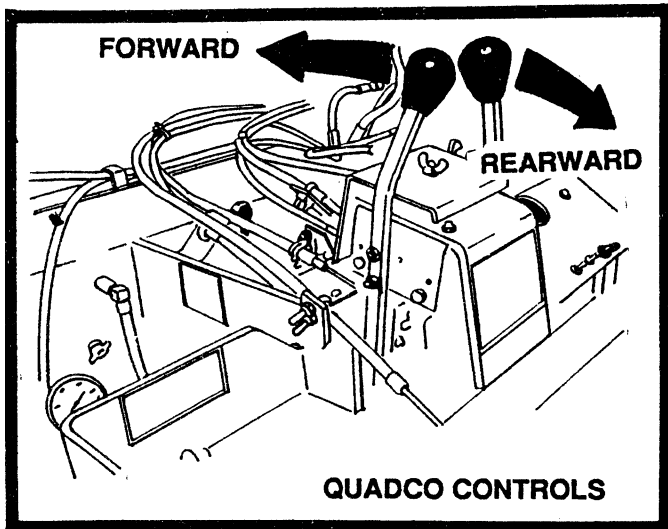

FIGURE 4

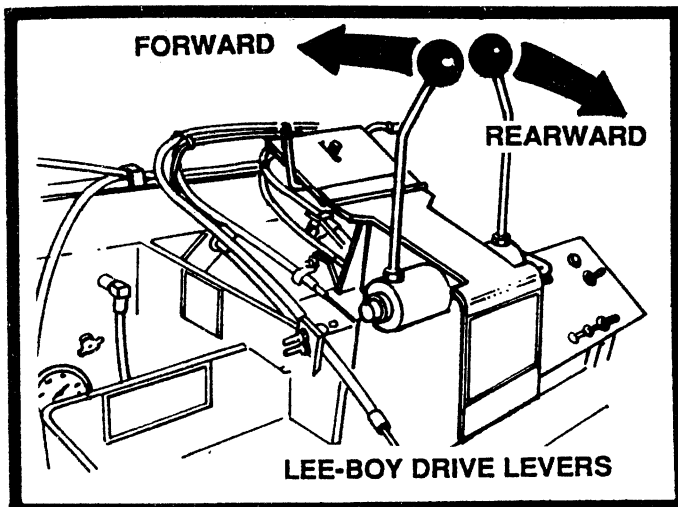

FIGURE 5

3. Depending on the direction of travel, turning the paver can be accomplished by pushing or pulling the steering lever on the inside of the turn toward the neutral position. Refer to figure 6.

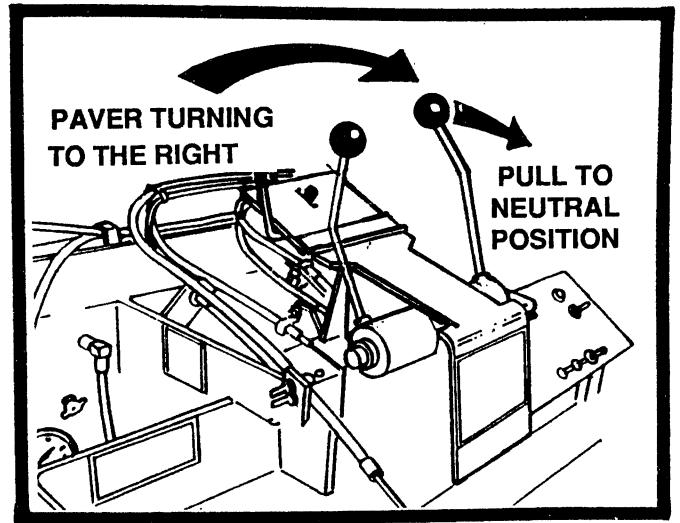

FIGURE 6

4. The traveling speed of the paver can vary greatly, depending on the steering lever position and the variable volume motor switch HI/LO position. The operator may make any combination of speed selection while moving.
5. When making forward/rearward or turns, always make these moves slowly. Move the steering levers slow and smoothly in the direction of intended travel.
6. When stopping, move both steering levers to the neutral position. See figure 7.
7. When paving, a constant speed is necessary to lay a even asphalt mat. Use the speed lock control to hold and retain steering levers in a fixed position.
8. To make a counter rotation movement, the steering levers are moved in opposite directions. The rotating speed can vary by the combination of HI/LO switch and steering lever positions.

### **! CAUTION !**

**NEVER SHIFT TWO SPEED TRANSMISSION WHILE MOVING OR ON INCLINE.**

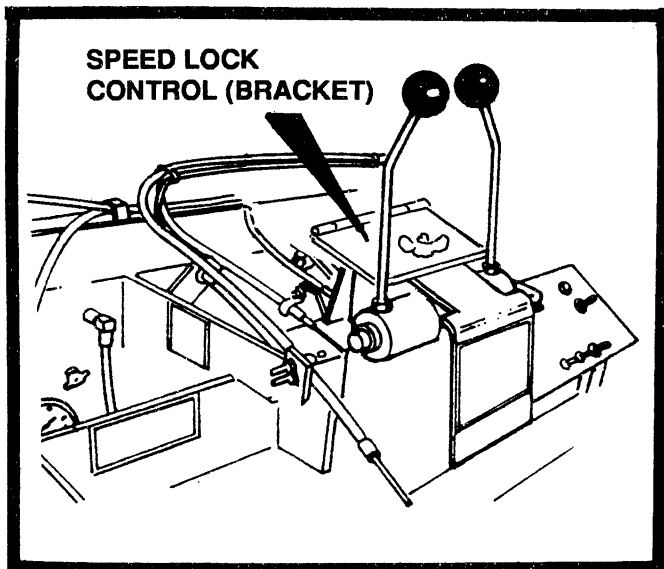

FIGURE 7

### TRUCK HITCH ATTACHMENT (OPTIONAL)

#### GENERAL

The truck hitch is an optional attachment to several "Lee-Boy" pavers. It was designed to improve the asphalt laying process. This is mainly accomplished by keeping the truck driver off his brakes, preventing excessive and uneven braking. See operating instruction below.

1. To connect truck hitch to rear of asphalt truck, extend the arm extensions of the truck hitch by pulling up on arm extension lever. See figure 8.

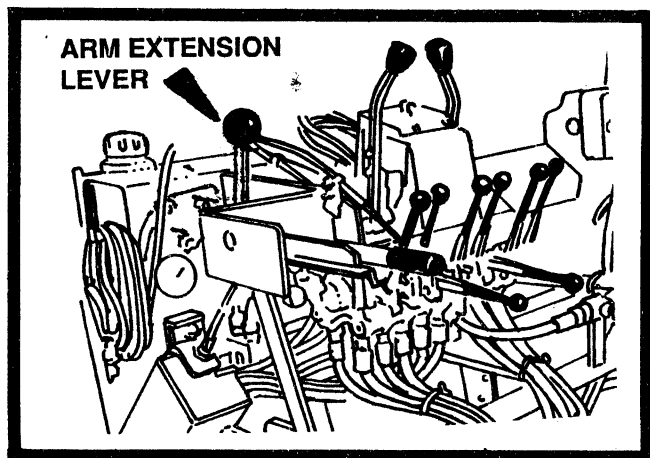

FIGURE 8

2. Drive paver slowly toward rear of truck until roll on hitch makes contact with rear tires of truck.
3. Retract the arm extensions until both guide rollers are fully locked into truck wheel rims.
4. May be necessary to adjust the roller guides to the inside of the wheel rims, initially. See figure 9.

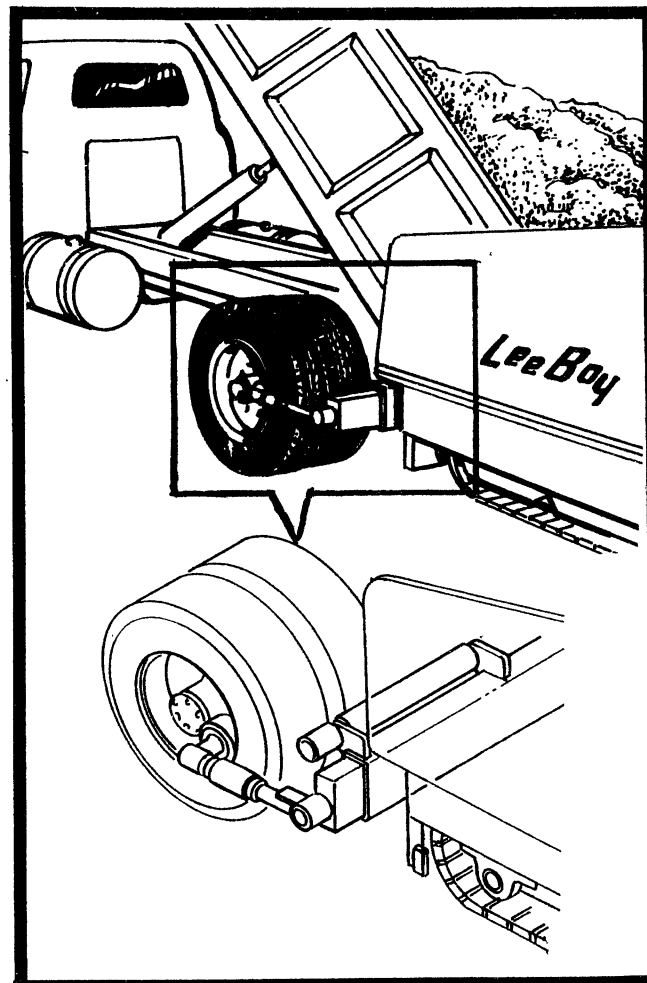

FIGURE 9

# PAVING PREPARATION INSTRUCTIONS

## LIGHTING BURNERS

### GENERAL

The heating of the screed will require extreme care. The propane gas used to heat the screed is a volatile combustible that if treated with respect will not present a problem. Follow the procedures below and refer to the illustration as required.

1. Turn main valve on the propane tank counter-clockwise to "on" position as shown in figure 10.

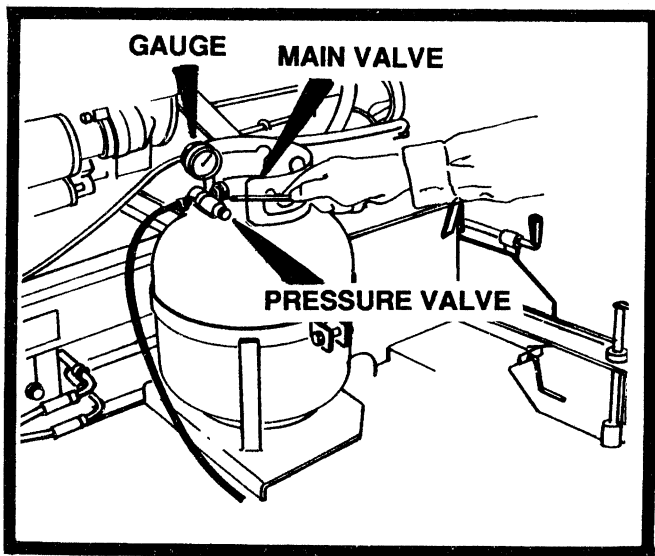

FIGURE 10

2. Adjust pressure valve in or out until gauge reads between 6 and 8 pounds as shown in figure 10.
3. Light ignitor as you open the ignitor valve. See figure 11.
4. Direct ignitor flame into hole in screed cover and turn burner valve to "on" position. When the burner is lit, follow same procedure for burner on opposite side as shown in figure 12.
5. Heat screed for no more than five to ten minutes before paving.
6. When turning off the burners, make sure that all valves are closed, including the main valve on the propane tank.

### **! CAUTION !**

**NEVER OPEN A VALVE TO BURNER UNLESS FLAME IS PRESENT. A BUILD UP OF UNBURNED GAS COULD RESULT IN A GAS EXPLOSION!**

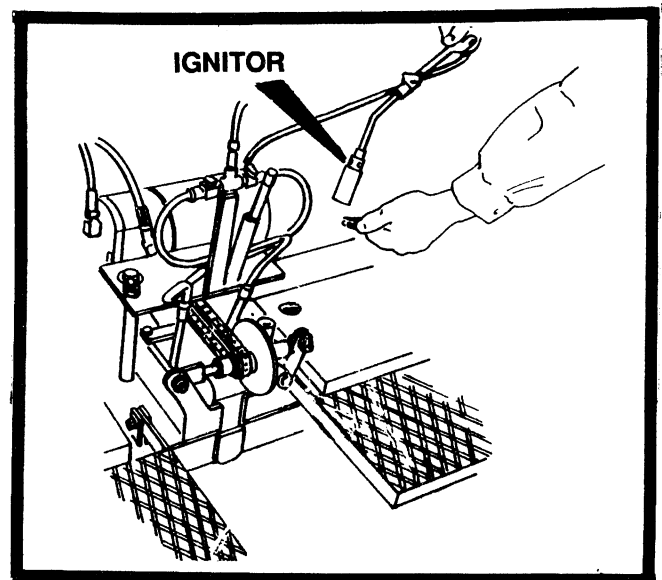

FIGURE 11

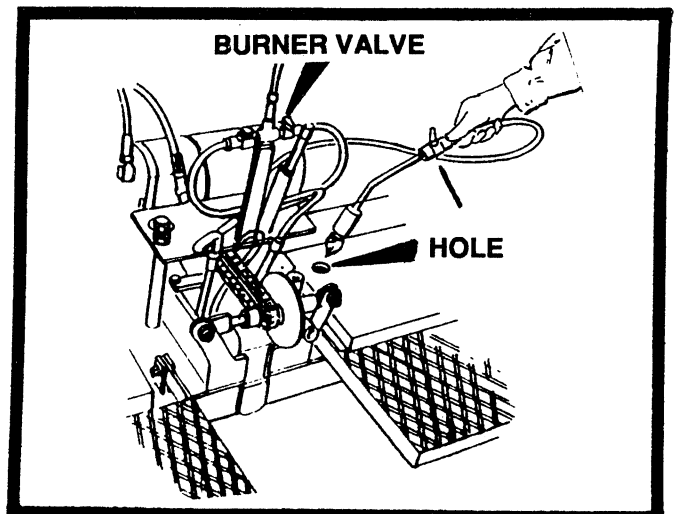

FIGURE 12

### NOTE

Heating the screed helps prevent hot mix from sticking to the cold screed plate and produces a smooth, tight mat surface. Heating should not only be performed at the beginning of the job, but also if the machine is idle for a long time between loads (allowing screed plate to cool).

### NOTE

If paving on a cool windy day it may be necessary to maintain low heat on the screed. To accomplish this, reduce the pressure on the propane tank from 6 - 8 pounds to 2 pounds. This will provide a low even heat that will not harm the screed. Do not attempt to regulate the burner with the burner valve.

### **! CAUTION !**

**IF FLAME COMES FROM END OF SCREED, SLOWLY TURN PETCOCK TO OFF. ALLOW FLAME TO GO OUT AND TURN PETCOCK BACK ON FULL.**

## **! CAUTION !**

**TOO MUCH HEAT FOR TOO LONG CAN WARP SCREED PLATE AND CAUSE MAT TEXTURE PROBLEMS. WARP SCREED SHOULD BE REPLACED.**

## **OPERATING FEEDER**

### **GENERAL**

The feeder is a very important part of the paver and for this reason close attention should be given on intergrading its operation into the total operation of the paver. Follow the procedure below.

1. Before raising or lowering feeders, fold sides in and out by hand. (The side rails have a double action motion causing the in and out movement.) Never use cylinder pressure to lower sides into place after lowering feeder, as this may bend sides or break the chains on the sides.
2. When lowering feeder, do not lower under pressure. Let the feeder down with engine shut off.
3. Do not let the paver set running with feeder on automatic any length of time, this may cause the hydraulic oil to over heat.
4. Spray the feeder drive chains periodically several times a day with diesel fuel.
5. When feeders are running and cutoffs are shut, there will be spillage the full width of the paver. This is normal and to help prevent this spillage, work feeders manually, when loading hopper and not paving.
6. When feeders light flashes on instrument console, this indicates that feeder flight chains need adjusting.

## **! CAUTION !**

**NEVER RAISE FEEDER WITH ASPHALT IN THE HOPPER.**

## **! DANGER !**

**NEVER WORK UNDER FEEDER WITH OUT MAKING SURE THAT FEEDER IS BEING SUPPORTED BY SAFETY PROP AND THAT ALL UNAUTHORIZED PERSONNEL ARE CLEAR OF THE AREA.**

## **OPERATION OF ELECTRIC FLIGHT SCREW**

### **GENERAL**

The electric flight screw is a added convenience to the operator, this will provide easier control of both sides of the screed.

1. Before paving, center the electric flight screw on both sides of the paver. See figure 13.
2. While paving, use the electric flight screws to make minor adjustments.

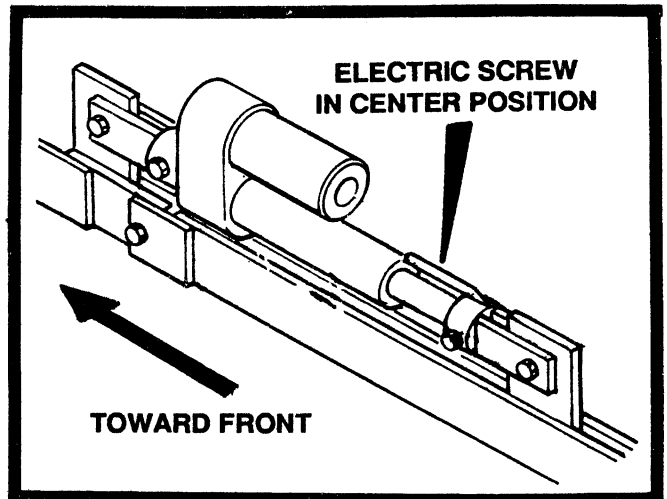

**FIGURE 13**

## **USE OF AUGER EXTENSIONS**

### **GENERAL**

The auger extensions should be attached to the main auger to increase the flow of asphalt. This will make it possible to lay asphalt at a higher rate. See auger extension attachment instruction below.

1. Identify the right and left auger extensions by looking for the L or R on the end of the auger extension shaft.
2. After identifying the right and left auger extension, extend the screed extension fully.
3. Shut off engine.
4. Remove bolt; nut cap on end of the main auger. Attach the correct side auger extension to the main auger with hardware just removed. Repeat this procedure for opposite side.

## OPERATION OF HYDRAULIC CUTOFFS

### GENERAL

The cutoffs are one of the most important functions of the paver, when used properly. Cutoffs are used primarily to control the flow of asphalt to the screed. Cutoffs can be used when making narrow passes, at the beginning and ending of each pass or pull. The cutoffs have been designed to break away if accidentally hits a man hole or ridge, this feature will prevent excessive damage to cutoff. (Tack underneath will break.)

1. Moving the hydraulic handle forward will increase asphalt flow to the screed pulling the handle back will decrease asphalt flow.

### NOTE

Always work cutoff valve handle one at a time when opening or closing. If both handles are worked together, normally one will open or close before the other.

2. Always pull valve handles to close. If handle is allowed to return to center position on its own, it may pass center and cause cutoff to drift open once pressure is lost.

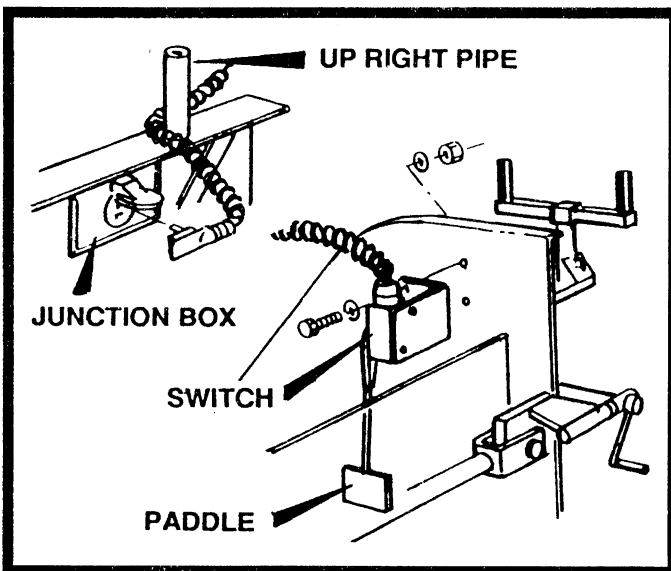

FIGURE 12A

## AUTOMATIC AUGER

### GENERAL

Automatic augers are used when laying mats wider than standard paving width. When used this will lessen the work load on the operator.

1. To install the paddle on the screed extension; extend the screed 6 inches and mount paddle on end gate as shown. Install the same way on left end gate. See figure 12A.
2. The routing of the electric cord is shown in figure 12A, for right side. The left side electric cord should be placed over top of screed lift bracket to the outlet box.
3. IMPORTANT: After the paddle on screed extension has been mounted DO NOT RETRACT SCREED FULLY, DAMAGE WILL OCCUR.

### **! CAUTION !**

WHEN USING AUGERS DO NOT TRY TO AUGER MATERIAL FROM ONE SIDE OF MACHINE TO THE OTHER SIDE. AUGER COVER IN CENTER BLOCKS THE FLOW. DAMAGE WILL RESULT IN BEARINGS AND COVER.

### NOTE

When paving basic width of machine augers are not required to run.

Continued next page...

## **ELECTRIC SPRAYDOWN**

### **GENERAL**

The spraydown on your machine is used to spray fuel oil on any part of the machine that comes in contact with the asphalt. Build-up of this material will cause damage to components. Spray the area often, the screed extension on top and bottom, augers and hoppers.

1. Unwrap the amount of hose needed and turn spray down switch on, pull wand handle and spray.
2. After spraying turn off spray down switch and rewrap hose.
3. **IMPORTANT:** When using spraydown consider the environment and do not allow fuel oil to run onto the ground.

### **! CAUTION !**

**IF SPRAY DOWN PUMP IS NOT TURNED OFF AFTER EACH USE, THE PUMP WILL RUN OVER BY PASS AND AFTER A PERIOD OF TIME WILL BURN UP MOTOR.**

## LOADING AND UNLOADING

### GENERAL

Trailers used to haul the paver should have ample capacity to carry the weight of the paver. Place the trailer in a clear, level area for loading or unloading.

Work slowly and carefully to avoid accidents. Keep the area clear.

### UNLOADING

1. Remove tie down equipment.
2. Start and warm up engine.
3. Set throttle at 1/2 operating RPM, shift transmission into low range. Set steering control levers so paver moves very slowly.
4. Make sure:
  - A. Screed position - UP
  - B. Extendable screed - IN
  - C. Gates below augers - CLOSED (Caution - Never back up with cutoff gates open.)
  - D. Speed range - LOW (Never shift Transmission on incline.)
5. Move the paver forward down the ramp as shown in figure 14.

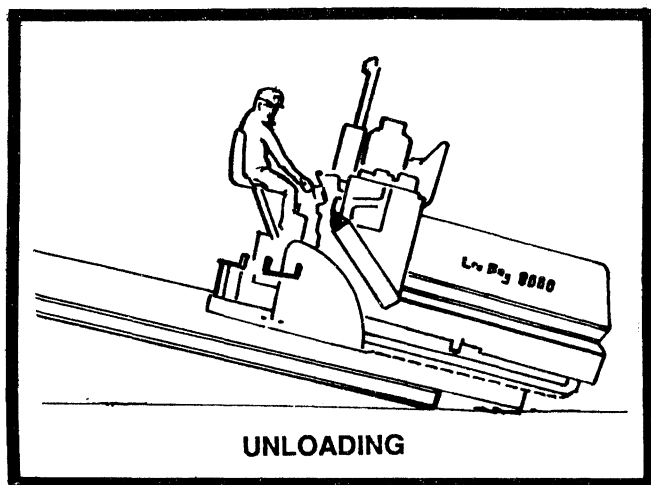

FIGURE 14

## **! DANGER !**

**MAKE SURE THE ENGINE IS RUNNING AT HIGH ENOUGH RPM'S TO PROVIDE THE HYDRAULIC PUMP WITH ENOUGH GALLONS PER MINUTE TO FUNCTION PROPERLY.**

### NOTE

A man should always be on the ground to assist the operator in the unloading function.

## **! CAUTION !**

**DO NOT LET THE SCREED STRIKE THE RAMP WHEN MOVING OFF THE RAMP. THIS CAN BREAK THE BEARINGS ON THE THICKNESS CONTROL SCREWS OR WELDS ON THE LEVELING ARMS. A LONGER RAMP OR BLOCKS MAY BE NECESSARY TO REDUCE THE ANGLE OF UNLOADING.**

### NOTE

If you have a problem unloading the paver - STOP — LOOK — THINK !

### LOADING

1. Move paver to base of ramp. Line up tracks with the ramp. Load paver screed end first. Set throttle at 1/2 operating RPM and steering control levers so paver moves very slowly onto the ramp.
2. Make sure:
  - A. Screed position is - UP
  - B. Extendable screed - IN
  - C. Gates below auger - CLOSED
  - D. Speed range - low (Never shift transmissions on grade).
3. With the steering control levers slowly guide the paver up the ramp. If the paver is loaded hopper first, the weight of the operator on the walkway will tend to tip the paver onto the screed. See figure 15.
4. When the paver has reached the desired position and is centered on the transport.
5. Lower screed to deck.
6. Shut down engine.
7. Secure paver to transport as directed by regulations.
8. Always have a helper on the ground who can assist the operator in moving the paver onto the transport.

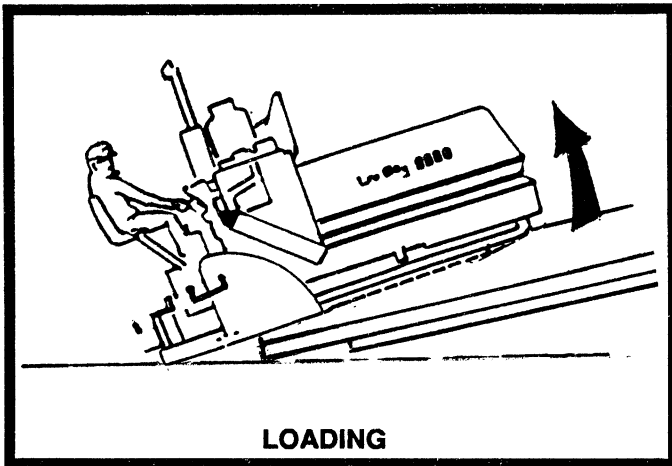

**LOADING**

**FIGURE 15**

### **TIE DOWN PROCEDURE**

1. Position paver on trailer centered from side to side.
2. Attach tie down chain to the hopper end of paver at the center hook provided.
3. On the rear of the paver attach a tie down chain through the crown control frame or if desired through the tie downs on each side of the paver.
4. Place chocks at wheels or tracks.
5. Make sure all chains are tight before moving.

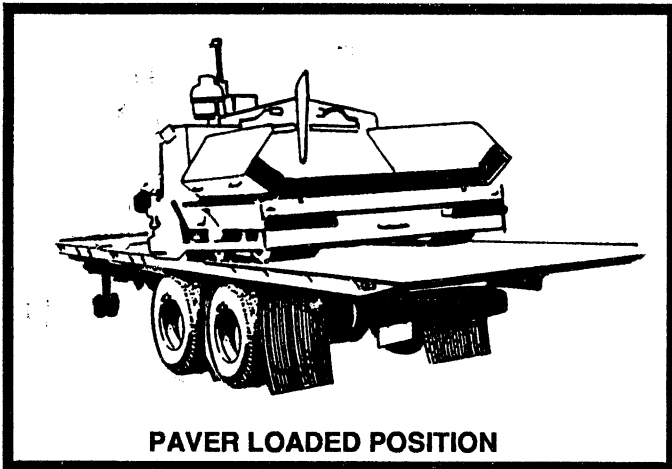

**PAVER LOADED POSITION**

**FIGURE 16**

## STARTING TO PAVE

### GENERAL

The paver is capable of placing bituminous base, binder and surface courses, lime or portland cement stabilized sub-base and graded aggregate materials up to a thickness of 6 inches. The paver has a production rate of 250 tons per hour.

Equipped with electric and manual thickness controls and a 8' to 13' wide screed, the paver can handle everything from driveways and small parking lots to large parking areas and secondary roads.

Before starting to pave, keep the following points in mind:

- A. Plan the project so that the narrowest passes are first, (the basic width of the paver) leaving the widest pass until last.
- B. Make sure to use a reference guideline. This can be a curb, gutter, adjacent mat or a string line. It is important that the first pass be straight as it will be the guideline for the following passes. Use the guidebar gauges as shown in Figure 17.
- C. Never run the paver through a pile of mix that has been dumped in front of the machine. Not only will this affect the level of the mat being laid but damage may result.

### NOTE

If paving on cool windy days it may be necessary to maintain low heat on the screed. To accomplish this, reduce the pressure on the propane tank from 6 - 8 pounds to 2 pounds. This will provide a low even heat that will not harm the screed. Do not attempt to regulate the burner with the burner valve.

### **! WARNING !**

**NEVER SPRAY DOWN PAVER WITH FUEL OIL WHILE BURNERS ARE LIT. A FIRE COULD CAUSE SERIOUS BURNS OR DEATH!**

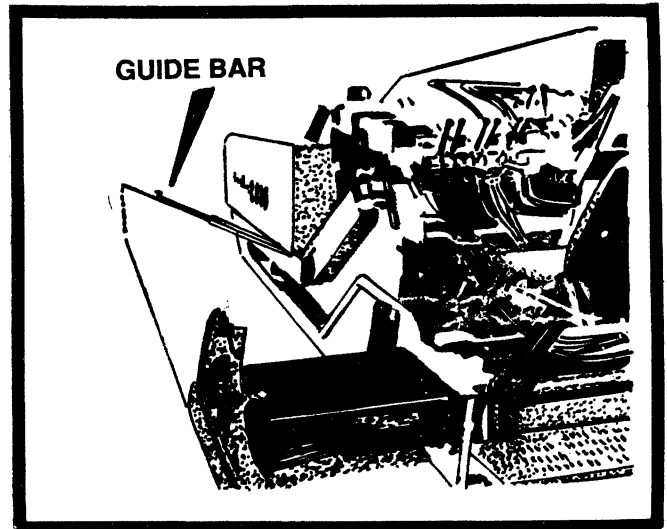

FIGURE 17

- D. It is the operators job to guide the truck up to the paver and signal driver when and how much to dump into hopper. Truck driver must maintain a light pressure on his brakes to keep truck from dumping material on the roadway in front of paver. See Figure 18.

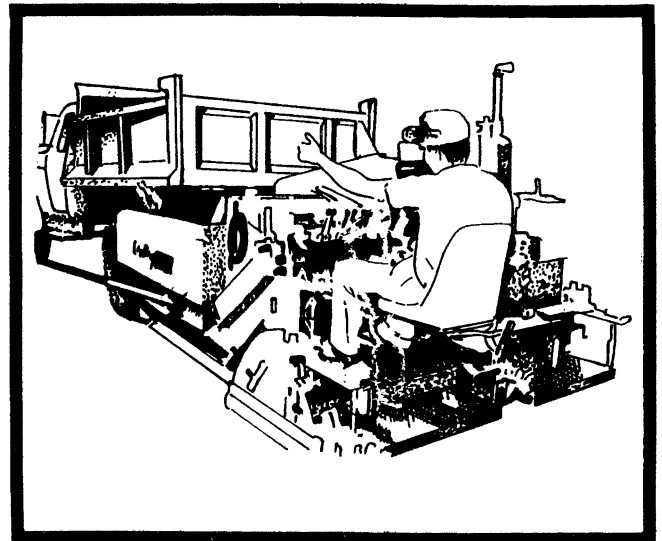

FIGURE 18

- E. Always pave in Low range.
- F. If paver is equipped with a truck hitch, refer to Truck Hitch Attachment instruction on page 10.

### **! DANGER !**

**BEFORE STARTING FORWARD WITH PAVER MAKE SURE NO ONE IS IN FRONT OF IT. THE LOW DECK PAVER WILL REQUIRE THE OPERATOR TO BE MORE ALERT.**

1. Raise screed and extend fully on both sides. Lubricate screed inserts with fuel oil and run the extendable screed in and out several times. Make sure end gate depth screw handles are locked after moving extensions to the desired depth. Spray the hopper, feeders and augers, auger gates of the screed plate with fuel oil as shown in Figure 19 and 20.

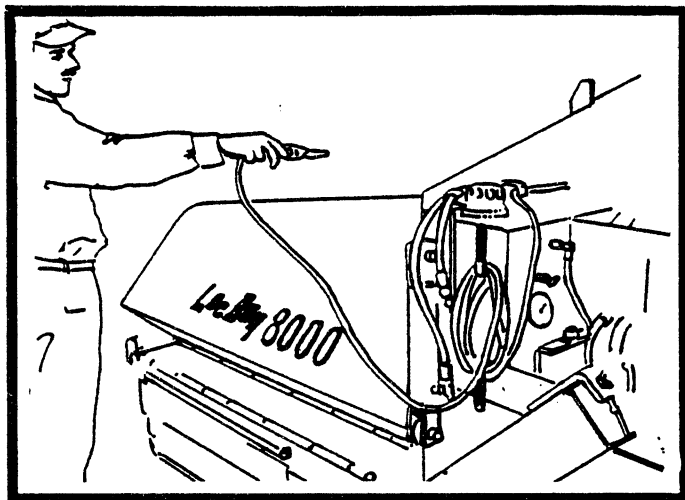

FIGURE 19

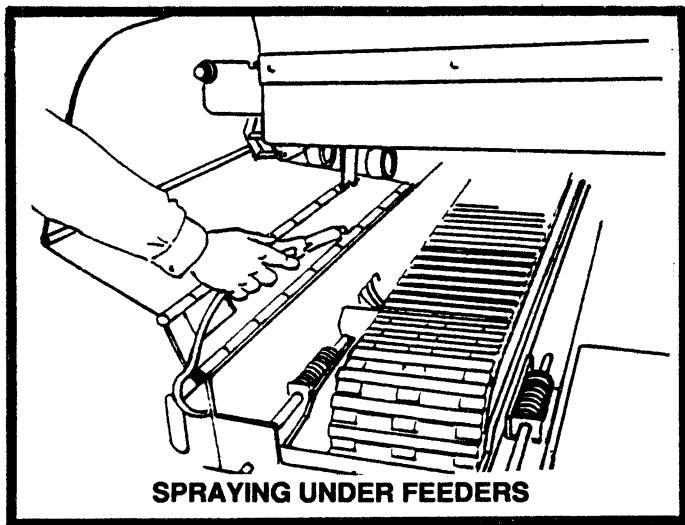

FIGURE 20

2. In figure 21 shows two methods of shifting the paver from HI to LOW gear. Item 17 High and Low gear, cable is used with the two speed transmission, push down to low gear, pull up to high gear. Item 15 High and Low, toggle is a toggle switch used with the Torque Hub, pull toggle switch down to low and push up to high gear. When the paver is equipped with torque hub, a high gear indicator light will be on steady, indicating that paver is in high gear. If this same indicator light is flashing, this means that the feeder chain will need adjusting.

**NOTE:**

Always stop two speed transmission paver before shifting gears. The torque hub paver may be shifted while moving. In both cases paving should only be done in low gear.

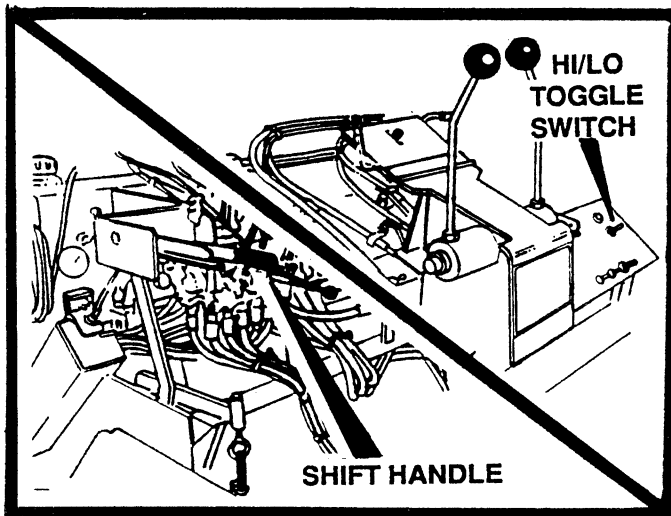

FIGURE 21

3. Light screed burners. Allow screed to heat for about 5 minutes. (After paving a short stretch, turn off screed heat; the mix will keep the screed hot.)
4. Move unit into paving position.
5. Place wood blocks under the screed as shown in Figure 22. These blocks should be slightly thicker (1/4 inch) than the finished (compacted) mat, to allow for reduction in thickness after rolling.

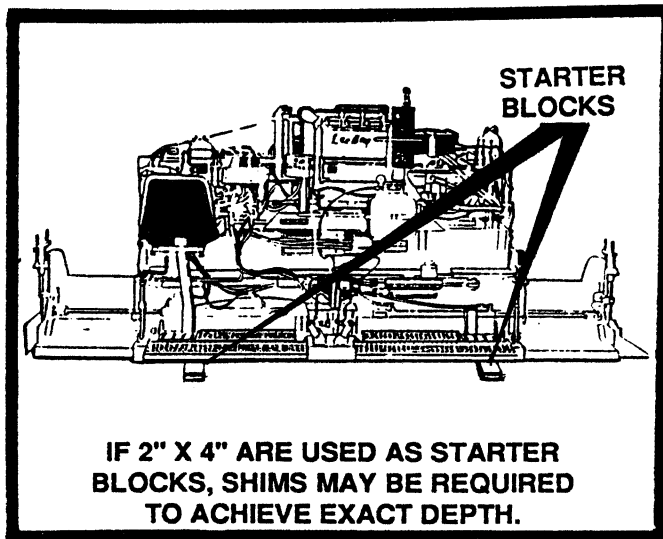

FIGURE 22

6. Adjust bottom of screed to lay flat on starting blocks. Turn flight screws one full turn toward thicker, this will lift the leading edge of the screed, preventing sag when leaving starting blocks. (Endgates can be used instead of starting blocks. Adjust end gates 1/8" to 1/4" shy of desired depth.) When paving at desired depth you should be able to feel free play in end gate. The free play indicates that the end gate is not carrying the load and that you are getting full compaction from screed.
7. Move forward get ready to make fine adjustments with thickness control screws. (Clockwise thicker paving, counter clockwise thinner).
8. Once the machine is paving the right depth desired. The runners on each end should be about 1/4" off the base to eliminate wear on the runners.

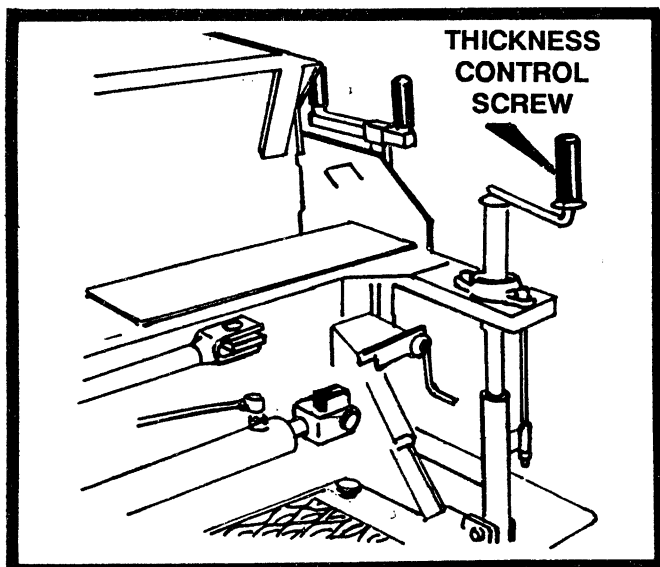

FIGURE 23

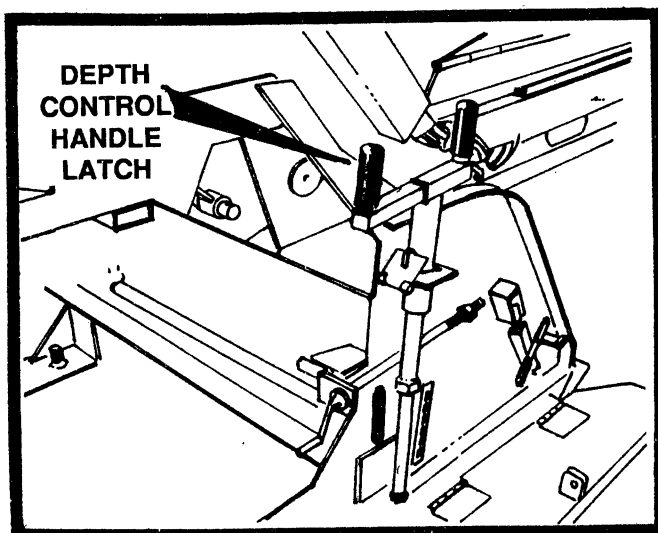

FIGURE 24

**NOTE**

Always make sure the depth control handles on the end gate are latched after each use to prevent damage when the extensions are retracted (See Figure 24).

Set crown control. The screed plate is a one-piece unit which is actually bent to provide the required crown setting. See Figure 25.

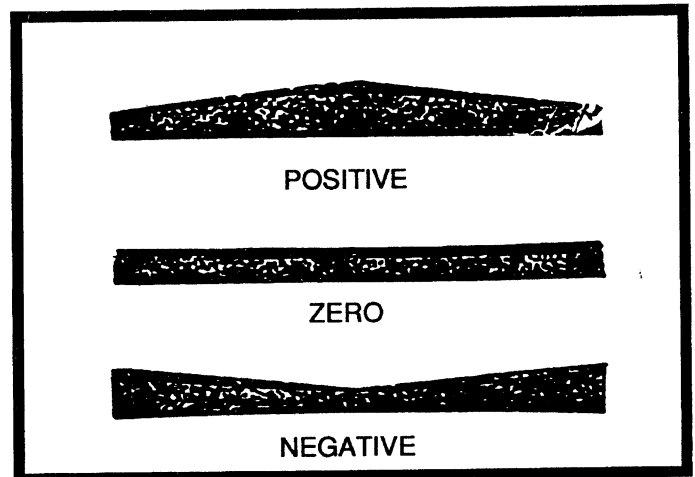

FIGURE 25

**NOTE**

Positive crown is when the middle of the mat is raised to permit water to drain to each side.

Negative crown is the lowering of the center of the screed plate. Negative crown might be used in an alley where drainage down the center of the alley is necessary.

Crown may be placed in the leading edge and/or the trailing edge of the screed plate. Crown in the leading edge aids material flow under the screed plate, only. Trailing edge crown puts a crown in the mat. As an example; trailing edge crown is 0, leading edge crown is 1/8". With this set-up there will not be any crown placed in the mat laid by the paver, however, material flow under the screed plate will be improved. Trailing edge crown is set at 0 when shipped from the factory. The chain connecting the leading and trailing edge crown control assures that the relationship of the edges remains constant as the trailing edge is changed to meet job conditions.

## ADJUSTING CROWN CONTROL:

- A. Loosen nut in slot under vibration motor as shown in Figure 26.

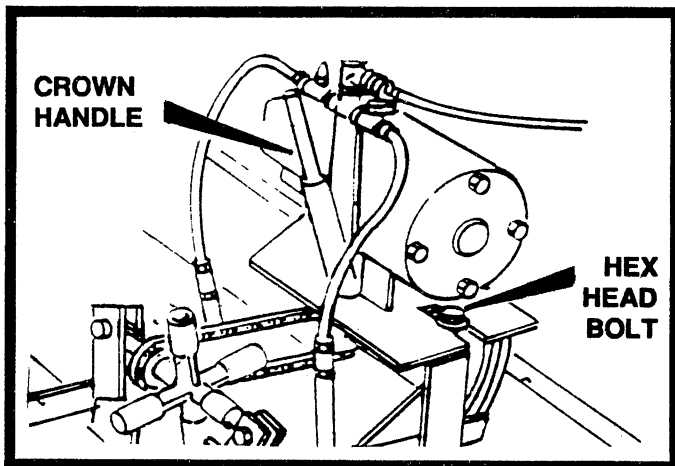

FIGURE 26

- B. Remove crown handle from holder and insert it into opening on control as shown in Figure 27.

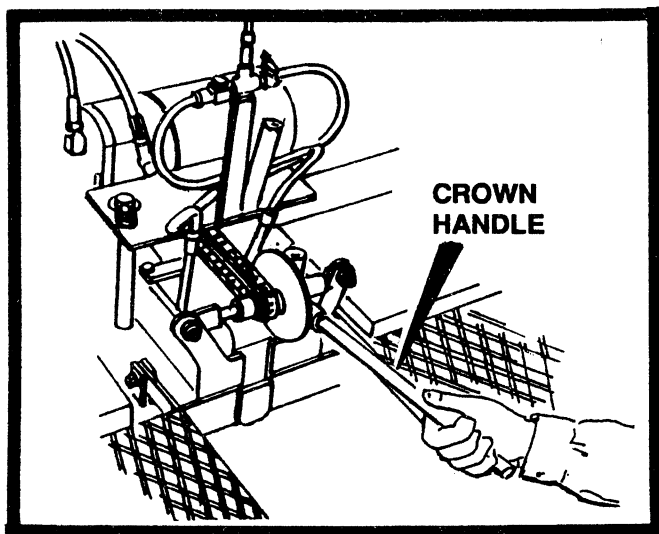

FIGURE 27

- C. Turn crown control -  
- down for positive crown  
- up for negative crown
- D. Re-tighten nut in slot under vibration motor.

### NOTE

If the job demands a specific amount of crown, it can be set by stretching a string line from one side of the screed to the other (along trailing edge). Turn crown control and measure from the center of screed plate to taut string line.

### NOTE

Regardless of the settings you have placed on the paver, the final judge of what you are doing is the mat itself. For instance, if you have set the crown on the screed, check the mat behind the paver to determine if you really are getting the crown you desire.

As you begin to pave, turn on the automatic feeders.

Begin paving the first pass following the guide line.

Reverse the paver and return to the starting point for the next pass. The depth control handle on the end gate (on the paved side) should be set so that the bottom of the end plate is about 1/4" below the screed plate if the adjacent mat has been rolled.

### NOTE

If possible, about 6 inches of the edge of the first pass should be left unrolled to allow a good joint to be made after the next pass is complete.

The second pass can be made with the truck backed up to the swivel front rollers of the paver as shown in Figure 28. The paver will push the truck; the driver should hold the truck brakes "on" *lightly* to keep the truck from moving away from the paver.

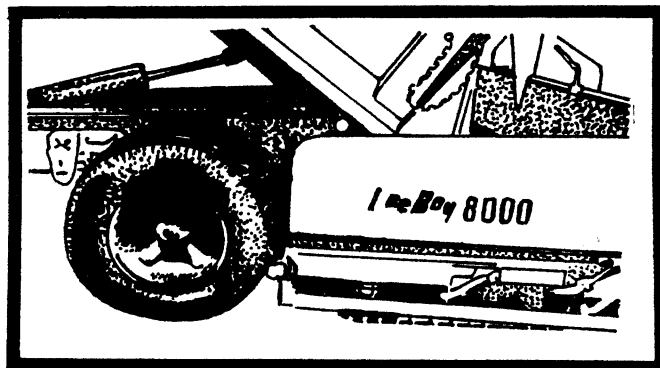

FIGURE 28

## ! CAUTION !

**TRUCK DRIVER SHOULD NOT HOLD BRAKES TOO TIGHTLY OR PAVES STEERING AND THE MAT WILL BE ADVERSELY AFFECTED.**

### NOTE

These paving directions are general in nature and cannot take into account unusual characteristics you will find on each job. It is therefore, the responsibility of the supervisor in charge to determine the exact paving pattern.

## ROUTINE MAINTENANCE

### GENERAL

Preventive maintenance on the Lee-Boy paver is a simple job that will provide years of trouble-free operation. Adjustments, also, are simple; they can be performed, in the field, with ordinary hand tools. Engine preventative maintenance, other than oil, air and fuel filter changes, is not covered in this section. Refer to engine operators manual for engine service information.

### 10 - HOUR OR DAILY ROUTINE MAINTENANCE

1. Cleaning the paver at the end of the working day while the machine is still hot is like putting money in the bank. A paver that is continuously left with mix stuffed in every corner is going to increase maintenance costs. Scrape off mix and spray fuel oil on the screed plate, hopper, etc., any place that has come in contact with the mix. Spray down the feeders while they are running. All cleaning should be performed while the machine is hot.

## ! CAUTION !

**IF MIX IS ALLOWED TO REMAIN IN THE MACHINE OVERNIGHT, POSSIBLE DAMAGE CAN RESULT ON START-UP THE NEXT DAY. POOR "HOUSE-KEEPING" WILL INCREASE MAINTENANCE COSTS.**

2. Raise feeders (See Adjustments - To Raise Feeders) and clean mix off all flat surfaces. This operation is quick and simple when the paver is still hot. **Immediately after raising feeders place the safety prop in position.**
3. Fill fuel tank for engine and spray down system to keep condensation from forming.
4. Perform engine preventative maintenance as described in your engine operators manual. Any engine preventative maintenance should always begin with an oil check. Also, check oil level in oil bath air cleaner. (If Equipped.)

5. There are five grease fittings that should be greased daily with a good grade of multipurpose grease. Two fittings are on the outside end of each auger and two on the conveyor pivot just ahead of the auger grease fitting. See figure 29.

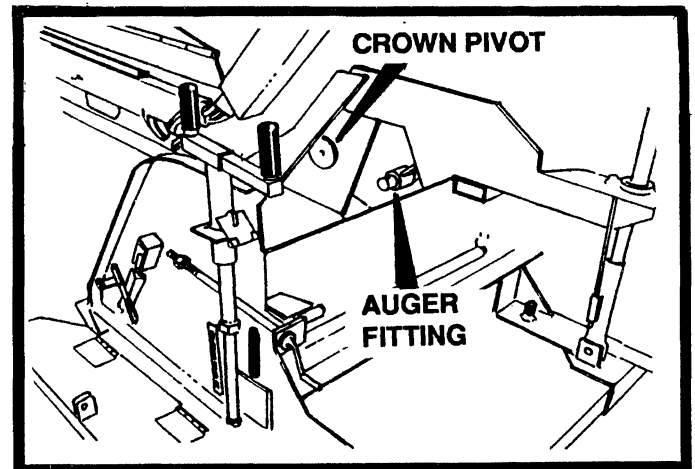

FIGURE 29

The center auger bearings are sealed for life.

The fifth grease fitting is on right, screed lift slide, behind the screed hoist cylinder. See figure 30.

Grease these fittings at the end of the day while the machine is still hot. This permits the bearings to be flushed of any asphalt or fines that may have worked into them.

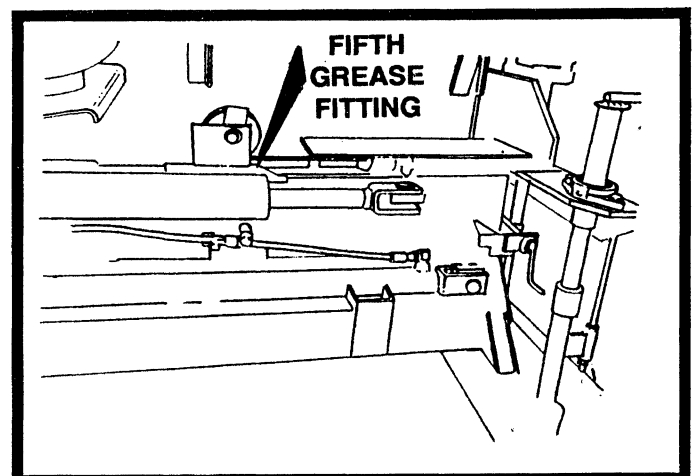

FIGURE 30

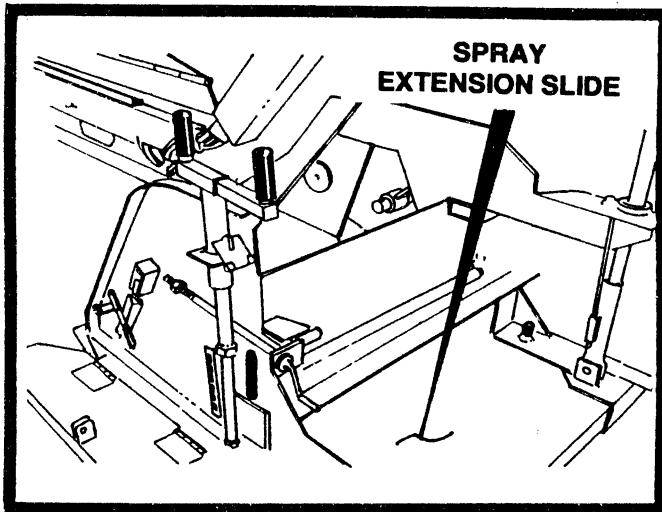

FIGURE 31

6. Spray thickness control screws with fuel oil to keep them working smoothly.
7. Grease extension slide with multi-purpose grease or spray with fuel oil at points shown in Figure 31.

**50 HOUR OR WEEKLY ROUTINE MAINTENANCE**

1. Check hydraulic oil and add if necessary.

**! CAUTION !**

**YOUR PAVER'S HYDRAULIC SYSTEM REQUIRES CLEAN, CONTAMINANT-FREE OIL. TAKE CARE WHEN WORKING WITH THE HYDRAULIC SYSTEM TO INSURE ITS COMPLETE CLEANLINESS. (15W 40 MOTOR OIL)**

2. Check that battery electrolyte level is to the full indicator and add clean distilled water, if required. Use a battery hydrometer to measure specific gravity in each cell. A fully charged battery will read 1.265 specific gravity at 80 F. (27C.). At the same time check all battery connections and remove any corrosion that is present.

**! DANGER !**

**DO NOT SMOKE WHEN OBSERVING BATTERY ELECTROLYTE LEVEL. THE FUMES CAN EXPLODE. ELECTROLYTE IS AN ACID WHICH CAN BURN IF IT CONTACTS SKIN OR EYES. IF CONTACT IS MADE, FLUSH AREA IMMEDIATELY WITH WATER.**

3. Check air cleaner, if the engine is equipped with a dry type element. Improperly serviced air cleaners wear out engines —FAST! In just a few hours a small amount of dirt will wear out a set of piston rings! Refer to your engine's operators manual for service information. Also perform any other engine preventative maintenance as described in the engine operators manual.
4. Clean screed insert. Remove screed insert by disconnecting extension cylinder and then pulling the screed straight out. See Figure 32. (When needed)

Remove asphalt that has accumulated inside screed.

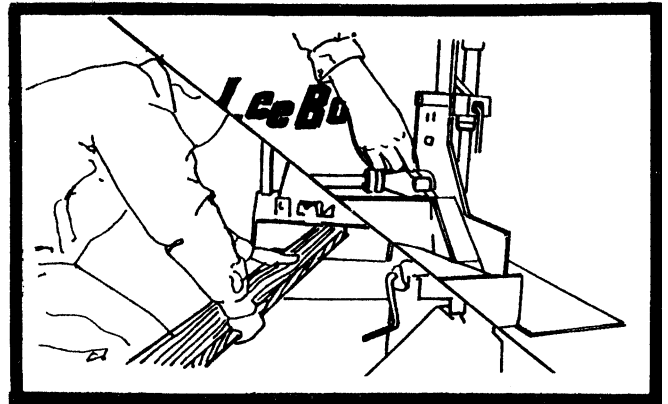

FIGURE 32

**100 HOUR OR MONTHLY ROUTINE MAINTENANCE**

1. Check oil level in the two transmission gear boxes as shown in Figure 33. If oil is required use 90 wt. gear oil. There is a dipstick provided to check oil level.

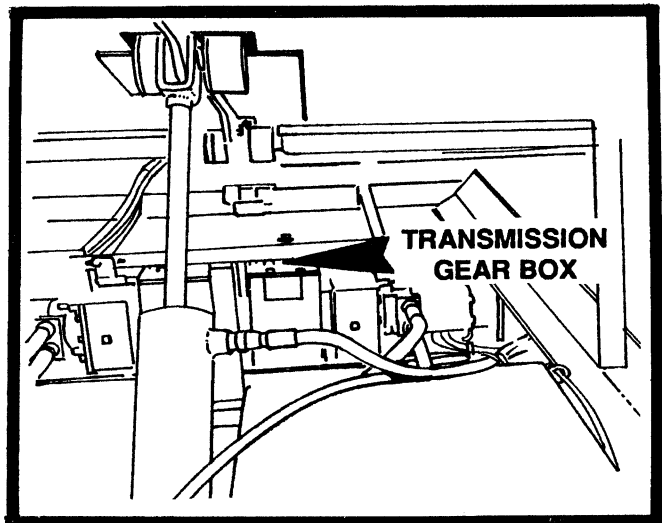

FIGURE 33

2. Check oil level in the torque hub by removing the plug at the 3 o'clock position. If oil comes out no oil is needed, insert plug and tighten. If oil does not come out, remove the plug at the 12 o'clock position and fill torque hub with **90 wt. gear oil** until oil starts to appear at the other hole. Replace both plugs and repeat process to other torque hub. See figure 34.

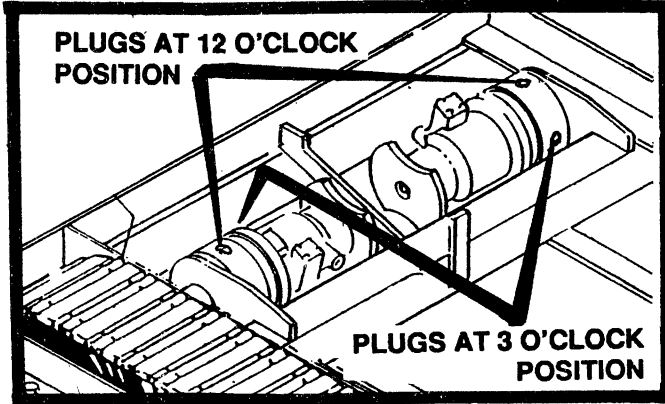

FIGURE 34

3. Replace dry type air filter, if equipped. Refer to your engine operators manual for service information.
4. Change engine oil. To assure complete removal of contaminants in the oil, perform the oil change while engine is warm.

After draining used oil, clean and reinstall drain plug and fill crankcase to the full mark with manufacturer's recommended oil. Change oil filter at every other oil change. (15 W 40 Motor Oil)

5. Change oil in oil bath air cleaner and rinse filter element in clean fuel to remove impurities. Also, perform any other engine preventative maintenance as described in the engine operators manual.
6. Check and adjust all chains, as required.
7. Grease conveyor bearing caps on rear of feeder. (outside)

### 250 HOUR OR QUARTERLY ROUTINE MAINTENANCE

Perform the 250 hour preventative maintenance as described in the engine operators manual.

1. Change filter charge between valve and pump.

### 500 HOUR OR SEMI-ANNUAL ROUTINE MAINTENANCE

1. All bearings are sealed and have grease fittings. These should be greased with multi-purpose grease using a handgun. Be careful to avoid blowing the seals.
2. Perform the 500 hour preventative maintenance as described in the engine operators manual.

### 1000 HOUR OR ANNUAL ROUTINE MAINTENANCE

1. Drain and flush the hydraulic tanks. A drain plug is located on the bottom of each tank for this purpose. The recommended hydraulic oil is 0 - 210° F SAE 10 W - 40 grade 46 oil.
2. Perform the 1,000 hour preventative maintenance as described in the engine operators manual.
3. Anytime the paver has been repainted or the decals have been removed, damaged or can't be read, a new set of decals should be ordered and re-installed for safe operation.

#### NOTE

When performing any routine maintenance such as 50, 100, 250, 500 and 1000 hour, always include previous routine maintenance hours to the higher hourly schedule.

#### IMPORTANT NOTICE!!

The changing of oil and cleaning of the paver should only be done in a designated area that can contain the oil and chemicals involved in any maintenance requirement. These by products should be discarded in accordance with environmental regulations.

**HYDRAULIC TANK**  
USE 15 W 40 S.A.E. MOTOR OIL

**ENGINE**  
USE 15 W 40 S.A.E. MOTOR OIL

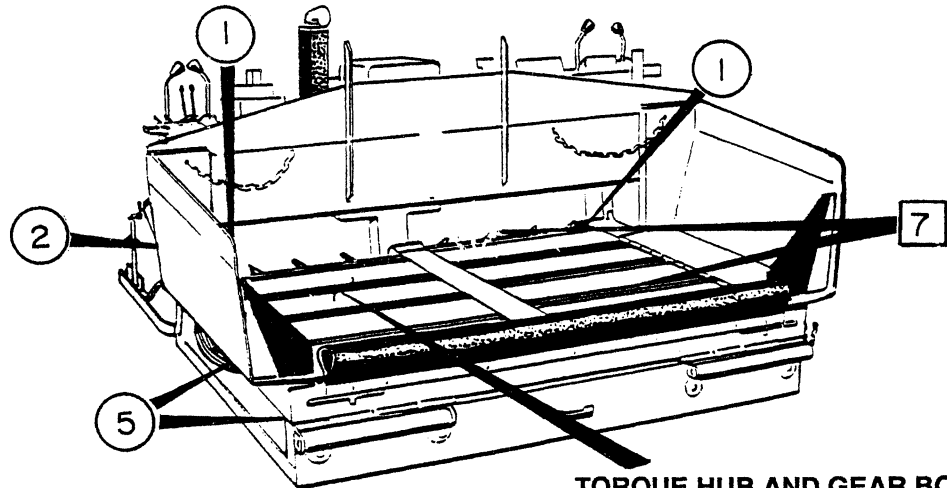
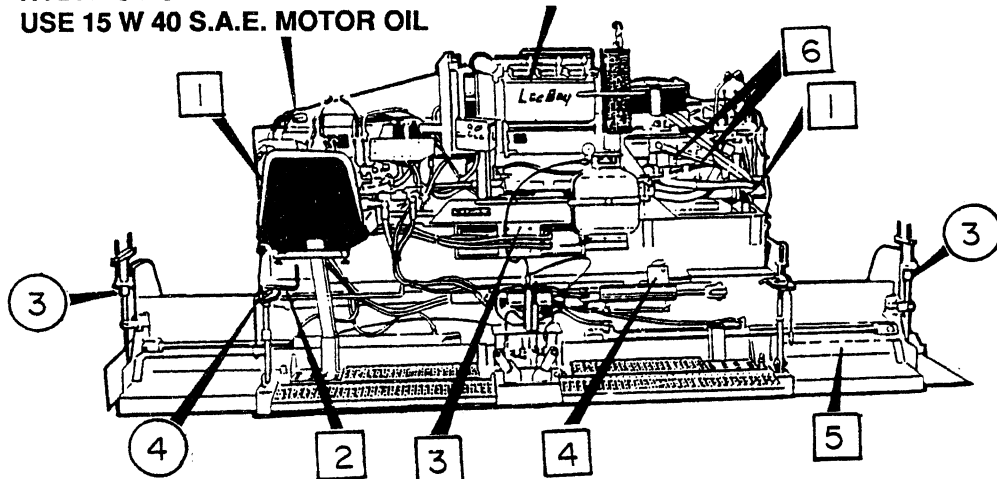

**TORQUE HUB AND GEAR BOX**  
USE 90 W GEAR OIL

### LUBRICATION CHART

Item No.	Description and Location	Interval
①	AUGER, each end of auger, (Best time at end of day)	Daily
②	FEEDER PIVOT, both sides, ahead of screed end	Weekly
③	DEPTH SCREW, grease first in lock position, unlock turn 180° and grease	Weekly
④	BEARING, on flight screw, both ends	Weekly
⑤	PILLAR BEARINGS, axle	3 Months
①	FEEDER CHAIN, left and right sides	Daily
②	PULLEY, screed lift, left side	Daily
③	AUGER CHAIN, middle of paver	Daily
④	PULLEY, screed lift, right side	Daily
⑤	SCREED EXTENSIONS, left and right (clean surface)	Daily
⑥	CABLE END, through out paver	Weekly
⑦	FEEDER AND AUGER, as shown	Daily

LEGEND      ○ GREASE WITH SHELL AVANIA EP GREASE 2 OR EQUIVALENT.  
                  □ SPRAY WITH FUEL OIL OR CHAIN LUBE

## MAINTENANCE ADJUSTMENTS

### TO RAISE FEEDERS

1. Fold hopper wings all the way in and pull bolts out. Grab top wings and pull out 5" or 6", then pull bottom handle out til wing knuckles in. To let wings down just pull on top of wing and let down to where bolts will go in. See figure 36.

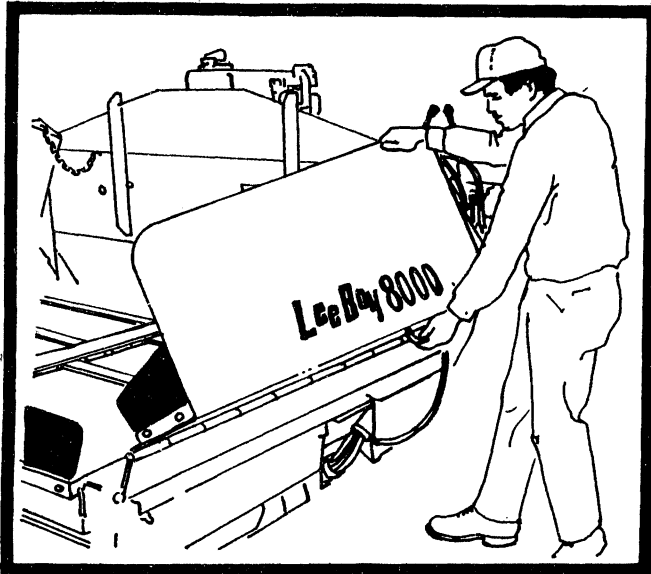

FIGURE 36

2. Raise feeders by pushing feeder lift valve forward. The location of this valve has purposely been placed in an inconvenient position to prevent the accidental raising of the feeders. See Figure 37.

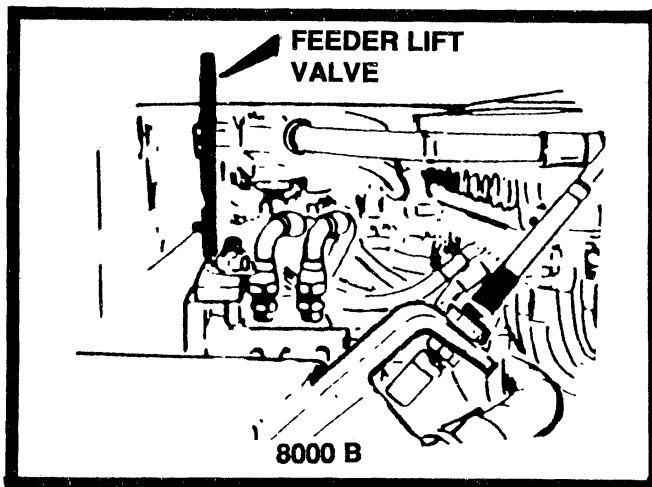

FIGURE 37

3. IMMEDIATELY AFTER RAISING FEEDERS, PLACE THE SAFETY PROP IN POSITION. See Figures 38 and 39.

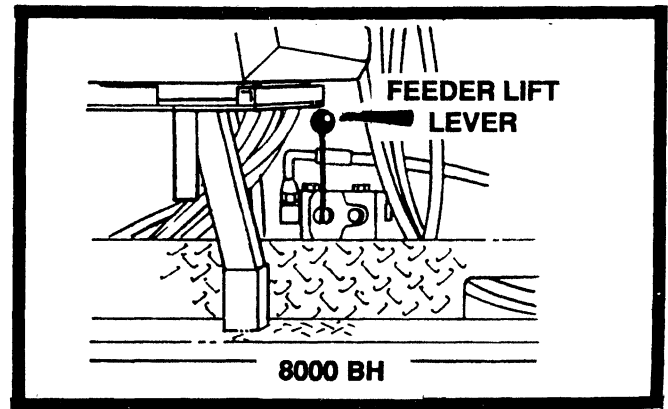

FIGURE 37

4. After the feeder is in position, lower the feeder onto the safety prop. This will provide an extra margin safety preventing safety prop from accidentally being dislodged.

**! CAUTION !**  
BEFORE RAISING OR LOWERING FEEDERS, FOLD SIDES INTO THE FULL IN POSITION.

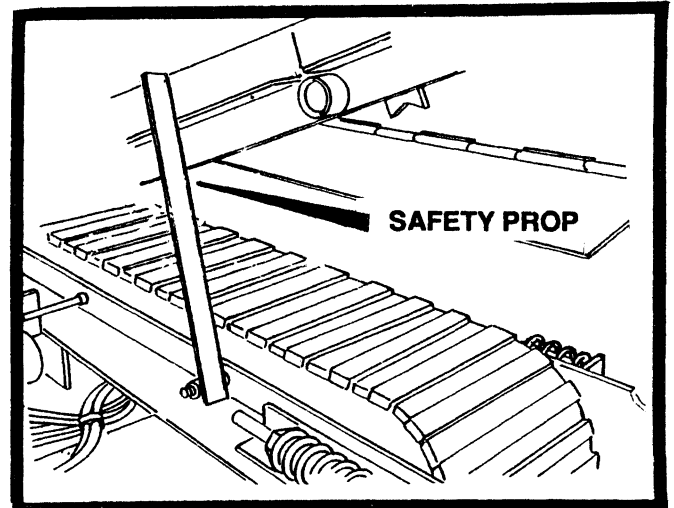

FIGURE 38

**! DANGER !**  
USE EXTREME CAUTION WHEN WORKING UNDER FEEDERS. CLEAR AREA OF UNTRAINED PERSONNEL. PLACE SAFETY PROP INTO SUPPORT POSITION AND LOWER FEEDERS UNTIL SAFETY PROP IS UNDER LOAD AND FIRMLY WEDGED.

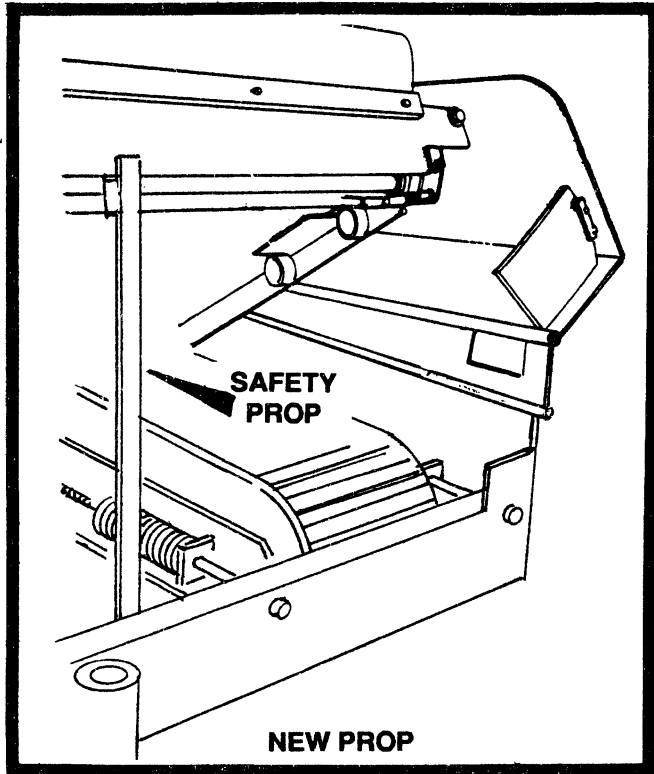

FIGURE 39

### LOWERING FEEDER

1. Before lowering the feeder, make sure that the area under the feeder is clear of tools or foreign objects.
2. Release safety prop carefully. This should only be done with a long probe such as a shovel or rake. If feeder has dropped firmly down onto safety prop it will be necessary to raise the feeder. After raising the feeder, turn engine off and release safety prop as instructed.
3. Lower feeder, but not under pressure. Allow feeder to come down with engine not running.
4. Fold side panels back with same in and out knuckle motion used to raise them.
5. Replace the four bolt-two on each side panel, and tighten.

### FEEDER FLIGHT CHAIN ADJUSTMENT

1. Raise feeders.
2. Secure safety prop to prevent feeders from accidentally lowering.
3. There is one feeder chain on each side of paver with 2 locking bolts and 2 adjusting bolts per feeder chain. When these adjustments require servicing a red light on the instrument panel will flash. Follow the procedures below in making this adjustment.
  - a. Loosen lock nuts on bottom side of feeder.
  - b. Turn adjusting bolts alternately until you feel the pressure of the chains tighten. (The correct way to tighten is to turn left bolt 1/2 turn, then right bolt 1/2 turn. Continue this sequence until chain is tight.)

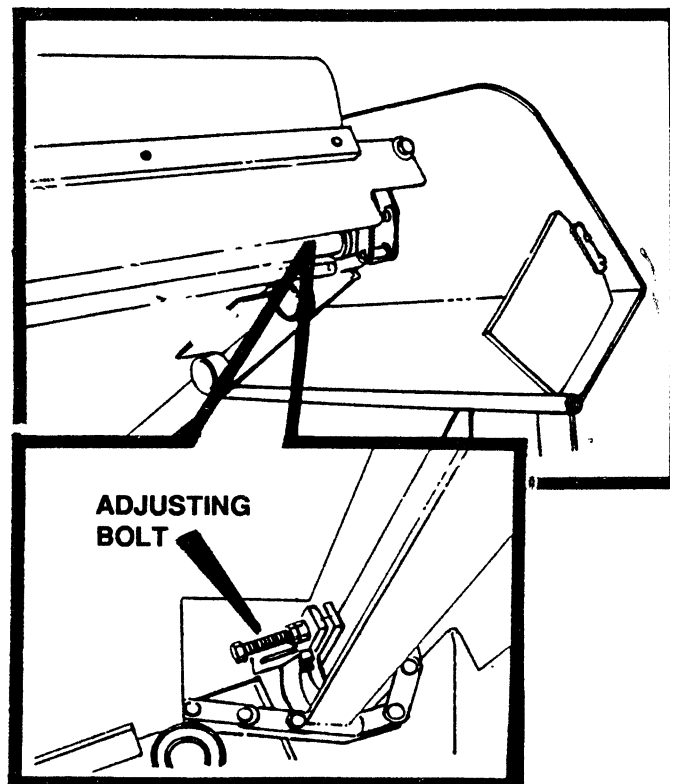

FIGURE 40

## TRACK ADJUSTMENTS

Tracks may be taken up through the adjustment on the front frame of the paver. To adjust crawlers, lay a straightedge on top of the track as shown in Figure 41.

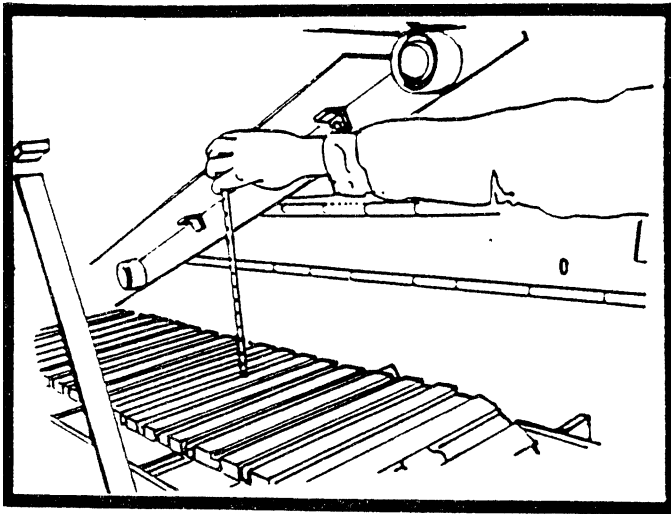

FIGURE 41

Measure the sag as shown. If sag is more than 1/2 inch, adjust the take-up. After taking up the slack make sure that the idler shaft is not cocked. Measure distance from shaft to front frame. Both measurements should be equal; if they are not, re-adjust. See Figure 42.

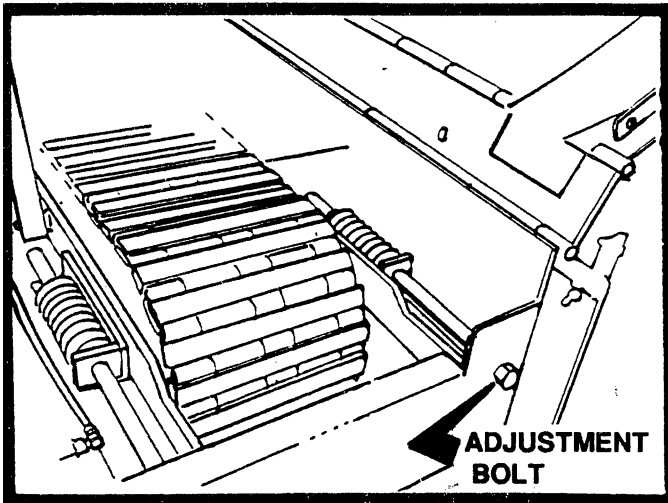

FIGURE 42

## FEEDER DRIVE CHAIN

1. Lower feeders.
2. Operate feeders.
3. Look at drive chain through the top of the frame. If drive chain has a whip in it, adjustment is necessary. See figure 43.

4. If adjustment is necessary, continue to operate feeders at fast speed and loosen the lock nuts on the chain adjustment. Turn the chain adjuster until the whip in the drive chain disappears.
5. Perform the same check on the opposite feeder.

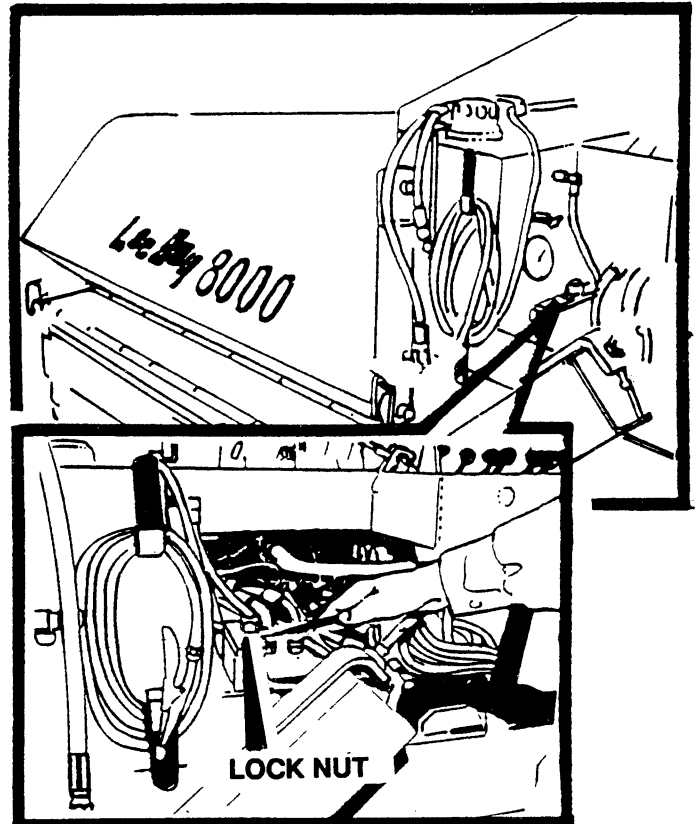

FIGURE 43

## AUGER DRIVE CHAIN

1. The auger chains should be just snug, not loose. To snug up, loosen bolts in slots provided for takeup. See figure 44.
2. Use a pry bar under hydraulic motor and pry to tighten chain. Feel the chain; if it is snug, retighten the lock bolts.

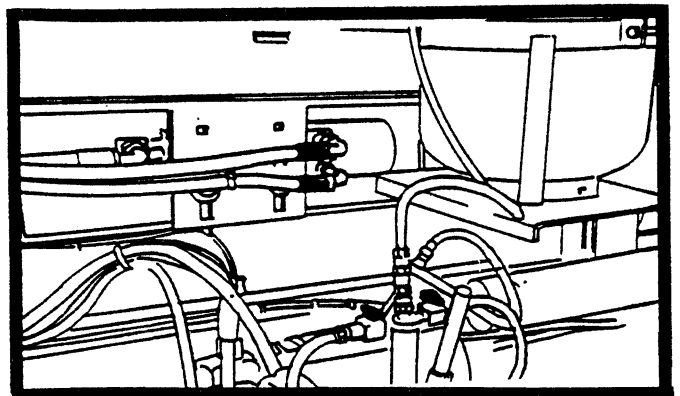

FIGURE 44

## Trouble Shooting Guide 8000

Problem	Probable Cause	Solution
Auger hanging up or will not turn	<ul style="list-style-type: none"> <li>• Chain too loose</li> <li>• Chain broke</li> <li>• Bad motor</li> <li>• Asphalt set up around auger</li> </ul>	<ul style="list-style-type: none"> <li>• Adjust Pg. 25</li> <li>• Replace</li> <li>• Replace</li> <li>• Keep clean and fuel oiled</li> </ul>
Screed extensions hanging	<ul style="list-style-type: none"> <li>• Asphalt set up around extension</li> </ul>	<ul style="list-style-type: none"> <li>• Keep cleaned and fuel oiled</li> </ul>
Screed extensions loose (work up and down)	<ul style="list-style-type: none"> <li>• Out of adjustment</li> </ul>	<ul style="list-style-type: none"> <li>• Adjust hold downs on extensions</li> </ul>
Screed leaving streak down center of pavement	<ul style="list-style-type: none"> <li>• Screed too flat (on leading edge)</li> <li>• Screed worn out</li> </ul>	<ul style="list-style-type: none"> <li>• Crown leading edge of screed</li> <li>• Replace</li> </ul>
Flight Screw Locking up	<ul style="list-style-type: none"> <li>• Twisting screed too far</li> </ul>	<ul style="list-style-type: none"> <li>• Give screed time to react</li> </ul>
Breaking of flight screw bearings	<ul style="list-style-type: none"> <li>• Loading and unloading</li> </ul>	<ul style="list-style-type: none"> <li>• Check ramps for easy access</li> </ul>
Flame coming out end of screed	<ul style="list-style-type: none"> <li>• Raw gas from burners</li> </ul>	<ul style="list-style-type: none"> <li>• Adjust burners in or out of hole.</li> <li>• Turn cutoff valve slowly to off, when flame goes out turn valve back on fully.</li> </ul>
Hydraulic oil running out of breather cap	<ul style="list-style-type: none"> <li>• Too full hydraulic oil</li> <li>• Air in bottom of tank</li> <li>• Oil over heated</li> </ul>	<ul style="list-style-type: none"> <li>• Drain 5" to 6" from top of tank</li> <li>• Bleed if you don't have vent hose</li> <li>• Slow machine down about 10% to 15%</li> </ul>
Auger handles will not Stay locked in	<ul style="list-style-type: none"> <li>• Detent worn out</li> </ul>	<ul style="list-style-type: none"> <li>• Replace detent</li> </ul>
Hydraulic pump cavitating or lost power	<ul style="list-style-type: none"> <li>• Low hydraulic oil</li> <li>• Clogged filters</li> <li>• Suction hose loose</li> <li>• Charge pump worn</li> </ul>	<ul style="list-style-type: none"> <li>• Fill</li> <li>• Replace</li> <li>• Retighten</li> <li>• Rebuild</li> </ul>
Engine will not start (Diesel)	<ul style="list-style-type: none"> <li>• Check Safety Switches Bad</li> <li>• Wires not making good connection on solenoid</li> <li>• Plug in switch box unplugged</li> <li>• Solenoid plunger sticking</li> <li>• Fuel solenoid coil burnt up</li> <li>• Blower belt broke</li> </ul>	<ul style="list-style-type: none"> <li>• Replace</li> <li>• Make sure wires are tight</li>   <li>• Plug back</li> <li>• Clean plunger</li> <li>• Replace coil</li> <li>• Replace Belt</li> </ul>

**NOTE:** Halz diesels are set up with a safety on starter, normally if the engine will not crank over it is the result of the starter relay. By pass this relay by finding terminal 50 on back of switch. Crimp new wire into this wire and run over to junction block, labeled No. 3. (Remove by pass relay.)

## Trouble Shooting Guide 8000

Problem	Probable Cause	Solution
Machine will not run straight	<ul style="list-style-type: none"> <li>• Quadco out of adjustment</li> <li>• Lee-Boy Drive Control</li> </ul>	<ul style="list-style-type: none"> <li>• Adjust Cables</li> </ul>
Machine will not pull on one or both sides	<ul style="list-style-type: none"> <li>• Shifter out of adjustment</li> <li>• Keys sheared in bull gear (Transmission)</li> <li>• Transmission Gear stripped</li> <li>• Bad Drive motor</li> </ul>	<ul style="list-style-type: none"> <li>• Readjust</li> <li>• Replace keys</li> <li>• Replace Gear</li> <li>• Replace</li> </ul>
Tracks not running smooth	<ul style="list-style-type: none"> <li>• Tracks too loose</li> <li>• Front idler out of line</li> </ul>	<ul style="list-style-type: none"> <li>• Tighten tracks Pg. 25</li> <li>• Readjust track</li> </ul>
Feeder does not work on one or both sides	<ul style="list-style-type: none"> <li>• Switch on automatic flaps out of adjustment</li> <li>• Wires on solenoid loose - not making good connection</li> <li>• Plunger sticking valve</li> <li>• Solenoid coil burnt up</li> <li>• Switch worn out</li> <li>• Toggle switches bad</li> <li>• Relief in valve stuck</li> <li>• Feeder drive chain broke</li> <li>• Feeder drive motor bad</li> </ul>	<ul style="list-style-type: none"> <li>• Adjust switch to where it clicks both ways</li> <li>• Adjust</li> <li>• Clean plunger</li> <li>• Replace coil</li> <li>• Replace switch</li> <li>• Replace</li> <li>• Take out, clean &amp; install</li> <li>• Replace</li> <li>• Replace</li> </ul>
Feeder flight bars hanging up	<ul style="list-style-type: none"> <li>• Flight chains too loose</li> <li>• Feeder drive chain too loose</li> </ul>	<ul style="list-style-type: none"> <li>• Adjust (See Pg. 24) If adjusted all the way and a link is removed you must install a 1/2 link.</li> <li>• Adjust (See Pg. 25)</li> </ul>
Loss of power to drives Feeders or Augers	<ul style="list-style-type: none"> <li>• Relief out of adjustment</li> <li>• Piston Groups worn in</li> <li>• Piggy back worn</li> </ul>	<ul style="list-style-type: none"> <li>• Check pressure</li> <li>• Replace</li> <li>• Replace</li> </ul>
Electric Screed don't work	<ul style="list-style-type: none"> <li>• Check Fuse</li> <li>• Check wiring</li> <li>• Bad actuator</li> </ul>	<ul style="list-style-type: none"> <li>• Replace</li> <li>• Make sure wires in tack</li> <li>• Replace</li> </ul>

### Hydraulic Pressures

Drive	• 2500 PSI
Feeders	• 2000 PSI
Augers & Cyl.	• 1800 PSI

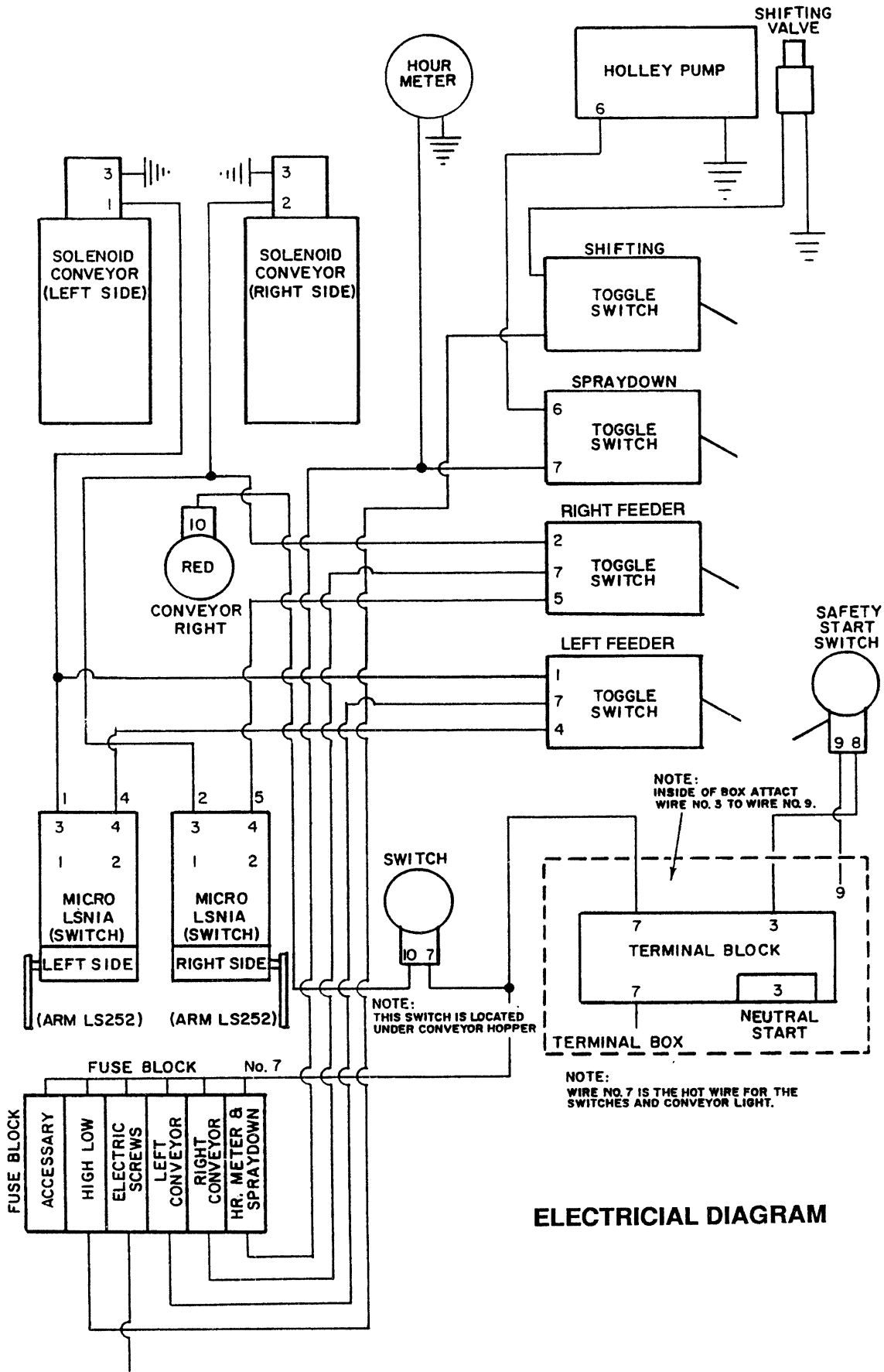

**ELECTRICIAL DIAGRAM**

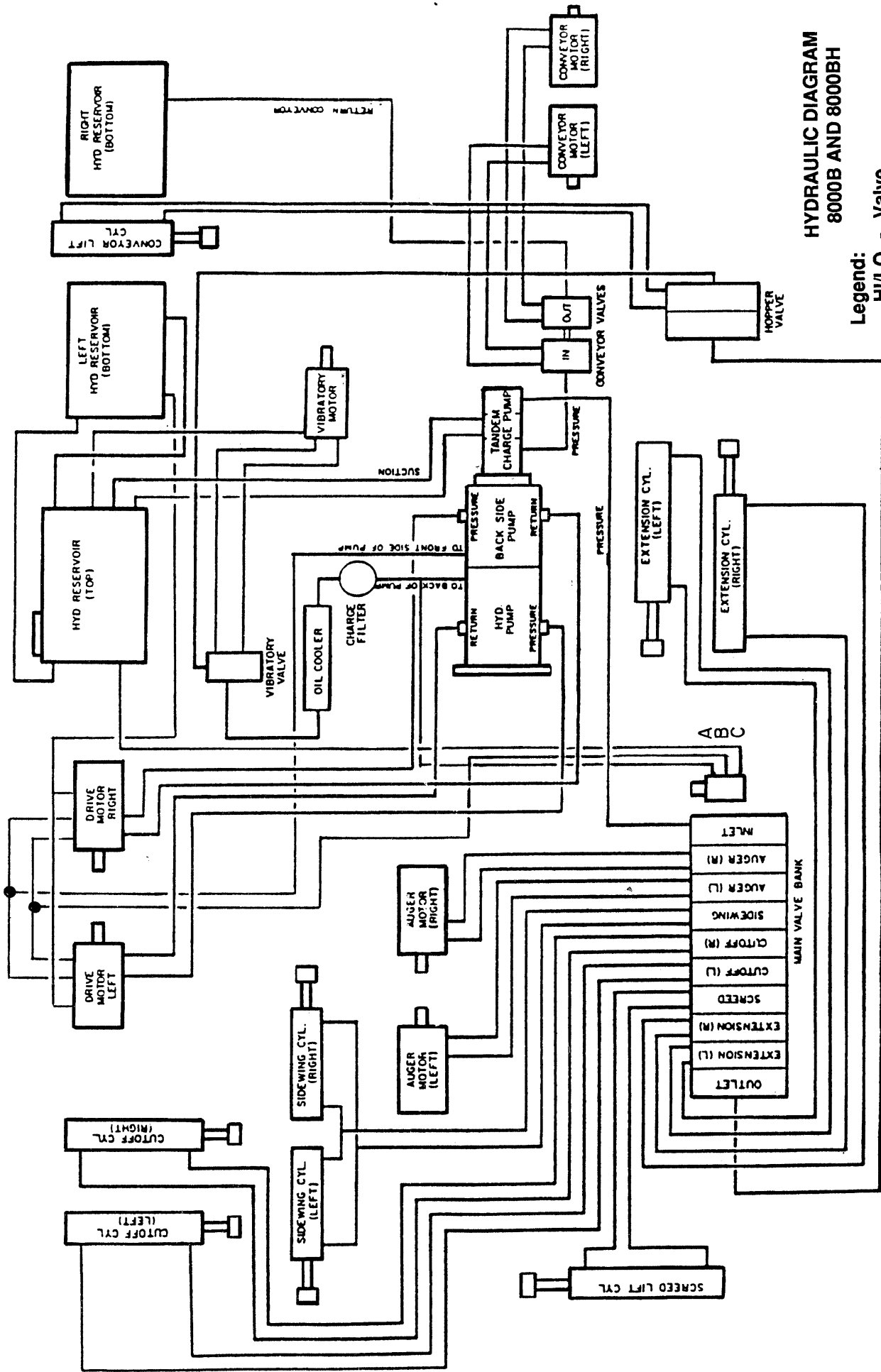

**HYDRAULIC DIAGRAM  
8000B AND 8000BH**

- Legend:**  
 HI/LO - Valve  
 A - Port, Charge  
 B - Port, Motor Hyd.  
 C - Port, Tank





# PARTS LIST

	Page #
TRACK DRIVE ASSEMBLY (with Box Transmission) .....	2
TRACK DRIVE ASSEMBLY (with Torque Hub) .....	4
RUBBER TIRE DRIVE ASSEMBLY .....	6
HOPPER COMPONENTS .....	8
CONVEYOR DRIVE ASSEMBLY .....	10
SCREED BACK ASSEMBLY .....	12 & 13
BASIC SCREED .....	14
AUGER ASSEMBLY .....	16
TRANSMISSION ASSEMBLY, Right hand Shown (from Serial no. 406B thru Present) .....	18
TRANSMISSION ASSEMBLY, Right Hand Shown (from Serial no. 282B thru 405B) .....	20
JOINTER ASSEMBLY .....	22
VIBRATOR ASSEMBLY .....	24
PROPANE HEATER ASSEMBLY & AUTOMATIC IGNITORS .....	26
TRUCK HITCH ASSEMBLY .....	28
SPECIAL COMPONENTS .....	30
ENGINE AND PUMP COMPONENTS .....	32
HYDRAULIC COMPONENTS .....	34
ELECTRICAL COMPONENTS .....	36
SAFETY & INFORMATIVE DECALS .....	38
SPROCKET DRIVE TRACK SYSTEM .....	40
HYD. COMPONENTS .....	42
SPECIAL COMPONENTS L/H SIDE (REAR) .....	44
MAIN VALVE .....	46
R/H DRIVE ASSEMBLY .....	48
PUMP COMPONENTS .....	50
FILTER LOCATION & ACCESSORIES (HATZ) .....	52
ENGINE COMPONENTS (HATZ) .....	54
DEUTZ COMPONENTS .....	56
DEUTZ ENGINE COMPONENTS .....	58
AUTOMATIC AUGER ELECTRICAL COMPONENTS .....	60
UMBRELLA .....	62

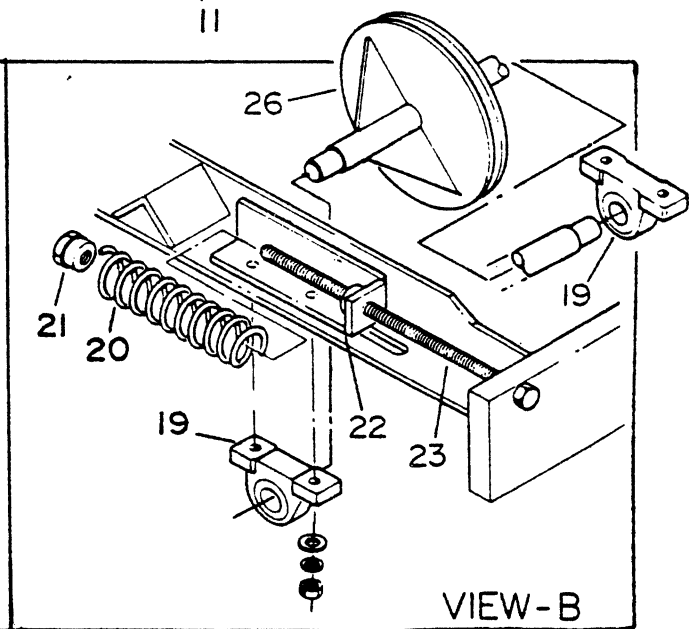
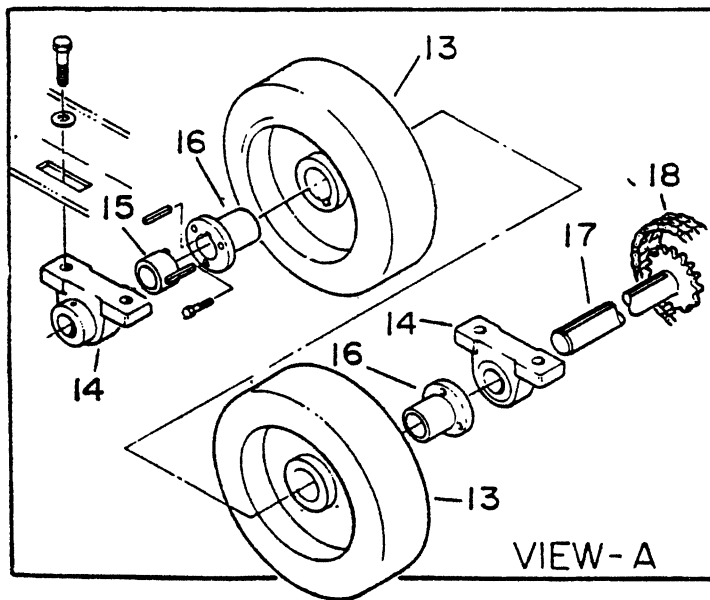
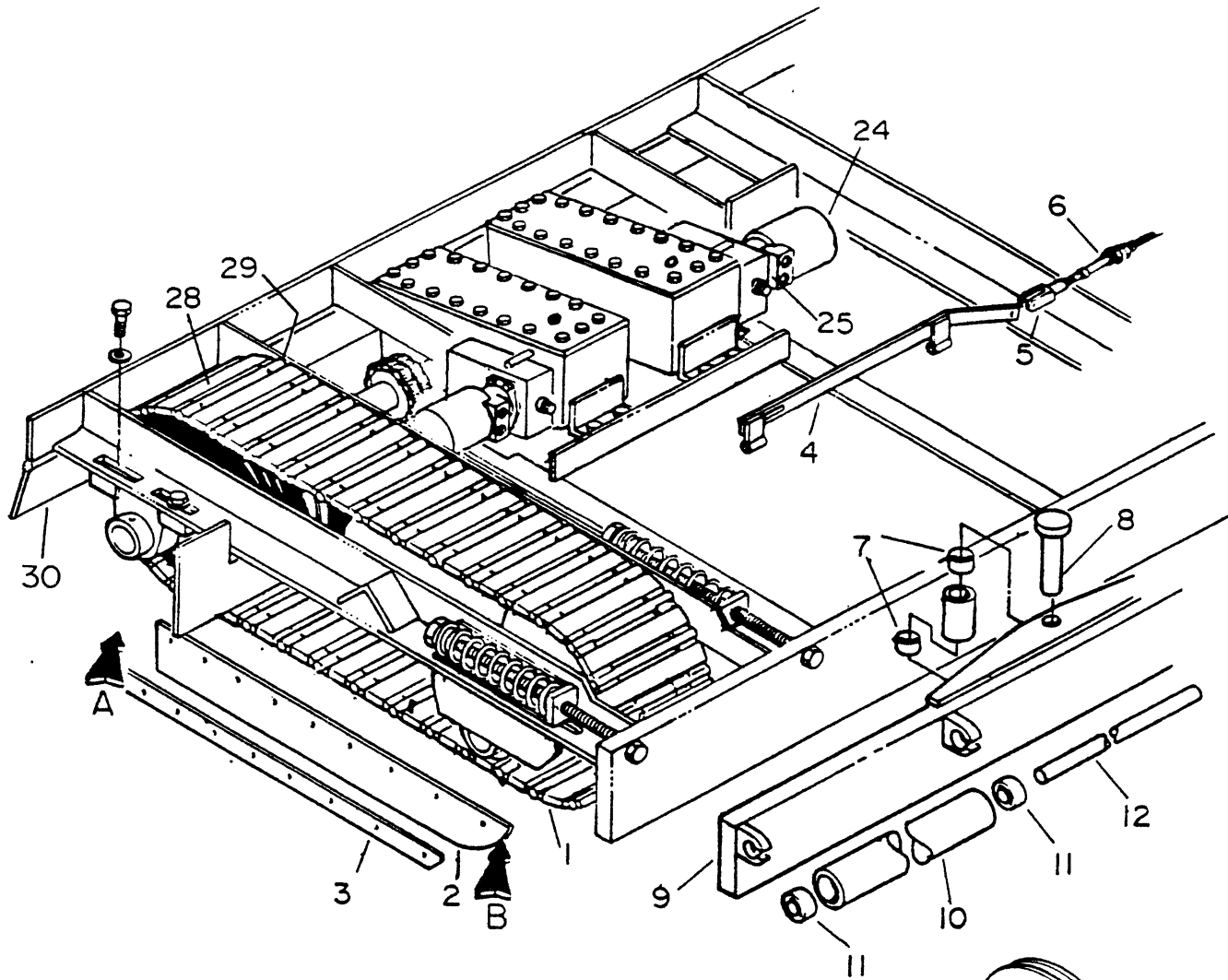

**TRACK DRIVE ASSEMBLY  
(With Box Transmission)**

ITEM NO.	PART NUMBER	DESCRIPTION	QTY.
1	810014	TRACK ASSEMBLY (Complete set)	2
2	810020	Shield	4
3	810031	Mount, shield	4
4	810042	Harness, shift	1
5	810050	Clevis, shift 3/8"	2
6	810060	Cable, shift 3" x 86"	1
7	810070	Bushing, oil lite	2
8	810081	Pin, pivot	1
9	810094	Bar, correction angle	1
10	810102	Roller, bumper	2
11	810110	Bearing, roller	4
12	810122	Shaft, bumper	2
13	810130	Tire, 6" x 16" (Molded)	4
14	810140	Bearing, pillowblock 2 1/4"	4
15	810151	Spacer	2
16	810160	Bushing, 2 1/4"	4
17	810172	Axle, rear 36" x 2 1/4"	2
18	810180	Chain, coupling (80)	2
19	810190	Bearing, pillowblock 2"	4
20	810200	Spring, adjustment	4
21	810210	Nut, backup	4
22	810222	Support, adjustment ( L or R, specify)	4
23	810232	Bolt, adjustment	4
24	810240	Motor, hydraulic drive	2
25	810250	Gasket, drive motor	2
26	810262	Idler, front 14 3/4"	2
27	810272	Roller, center (NS)	2
28	810281	Section, track	A/R
29	810291	Pin, master-track	A/R
30	811170	Cutoff, complete 94"	1
31	811172	Prop. Conv. (N/S)	1
32	810183	Double 80 Master Link, Chain Coupling (N/S)	2
<b>*WHEN ORDERING SEAL KITS GIVE TYPE OF MOTOR AND MODEL # OF MOTOR*</b>			
33	860020	<u>Seal Kit For Drive Motor</u> Kit, Seal (Drive Motor) (Ross) (MB12) (1 1/4" Spline)	1
34	870312	<u>Seal Kit For Cylinder</u> Kit, Seal (Cutoff Cylinder) (2 1/2" x 4") (Bobalee)	1

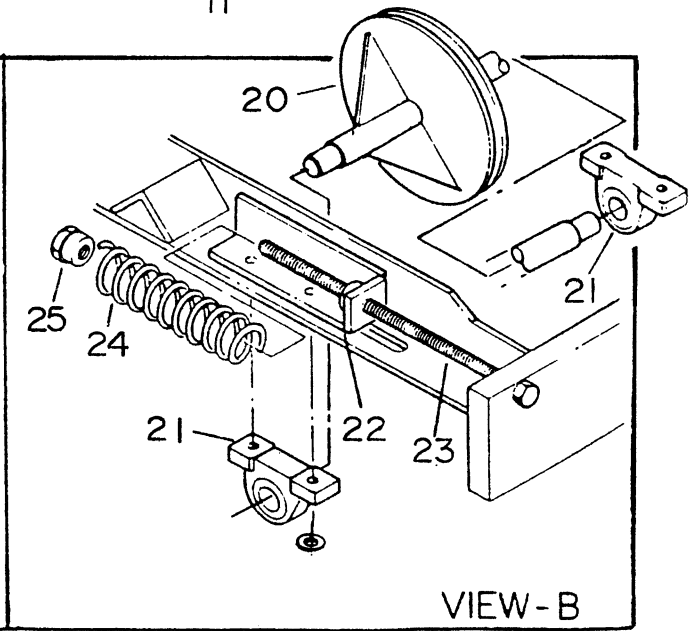
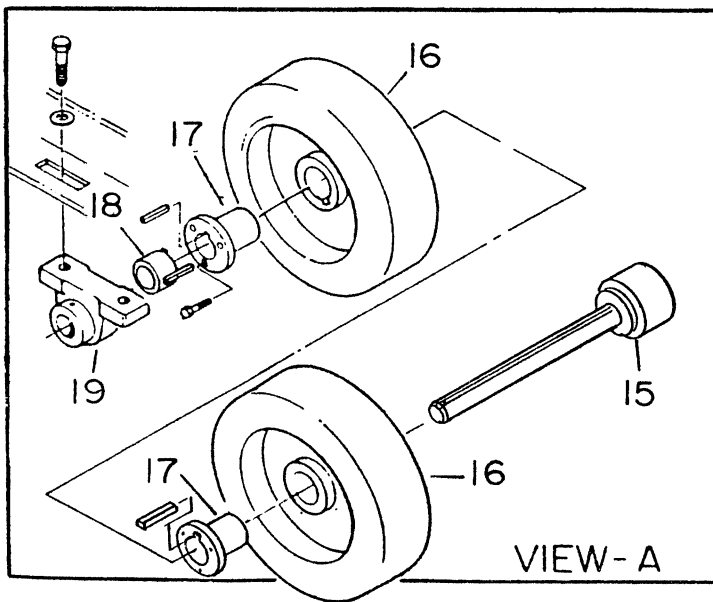
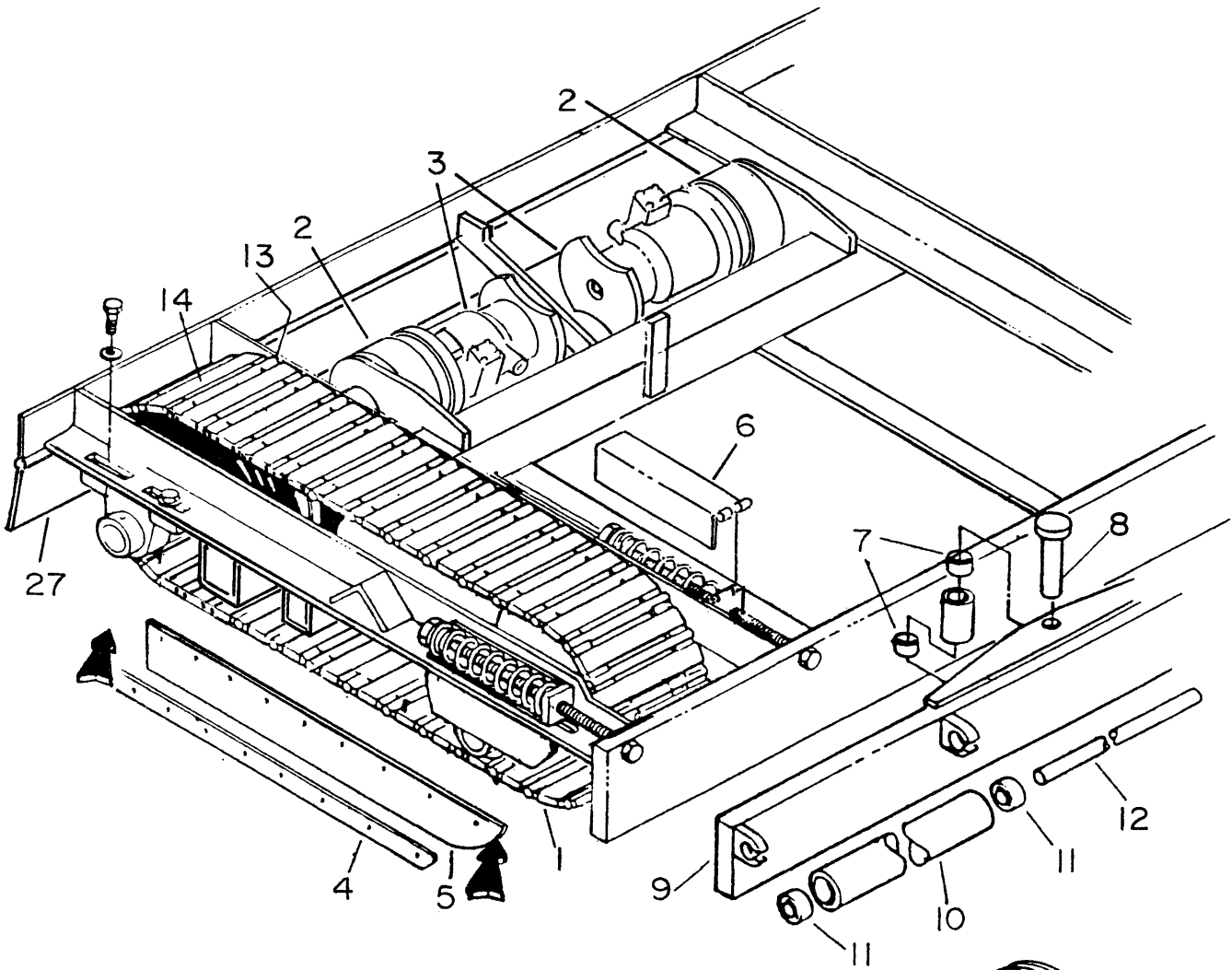

## TRACK DRIVE ASSEMBLY (With Torque Hub)

ITEM NO.	PART NUMBER	DESCRIPTION	QTY.
1	810014	TRACK ASSEMBLY (COMPLETE SET)	1
2	811020	Torque Hub	2
3	811030	Motor, Hydraulic	2
4	810031	Mount, Shield	4
5	810020	Shield-track guard (Rubber)	4
6	811060	Guard, Adjustment	4
7	810070	Bushing, Oil Lite 2"	2
8	810081	Pin, Pivot	1
9	810094	Bar, Correction Angle	1
10	810102	Roller, Bumper	2
11	810110	Bearing, Roller 1 1/4"	4
12	810122	Shaft. Bumper	2
13	810291	Pin, Master (Track)	A/R
14	810281	Section, Track	A/R
15	811150	Axle, rear	2
16	810130	Tire, 6" x 16" (Molded)	4
17	810160	Bushing, 2 1/4"	4
18	810151	Spacer	2
19	810140	Bearing, Pillow Block 2 1/4"	2
20	810262	Idler, Front new style 14 3/4"	2
21	810190	Bearing, Pillow Block 2"	4
22	810222	Support, Adjustment (L or R, Specify)	4
23	810232	Bolt, Adjustment	4
24	810200	Spring, Adjustment	4
25	810210	Nut, Backup	4
26	810272	Roller, center (NS)	2
27	811372	Cutoff, complete 94"	1
28	811172	Prop., Conv. - (N/S)	4
<b>*WHEN ORDERING SEAL KITS GIVE TYPE OF MOTOR AND MODEL # OF MOTOR*</b>			
		<b><u>Seal Kit For Drive Motor</u></b>	
29	870310	Seal Kit, (For Drive Motor) (Sunstrand M46) (N/S)	1
30	870312	Kit, Seal (Cutoff Cylinder) (2 1/2" x 4") (Bobalee) (N/S)	1
31	811365	Kit, Seal (Torque Hub) (N/S)	1
32	811366	O-ring (Torque Hub To Motor) (N/S)	1

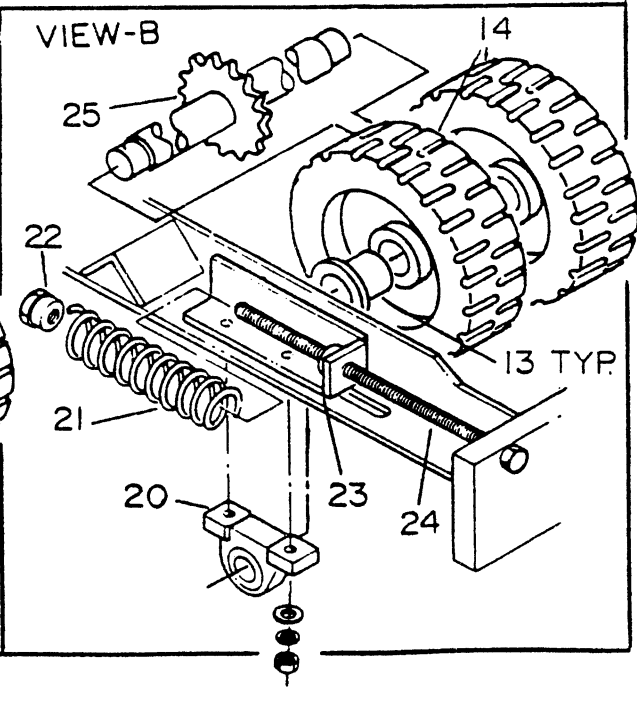
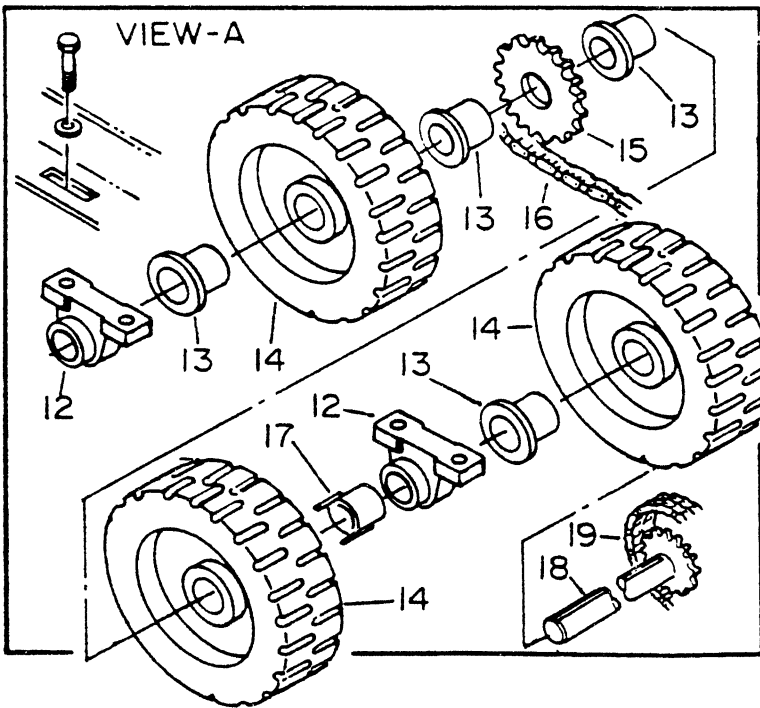
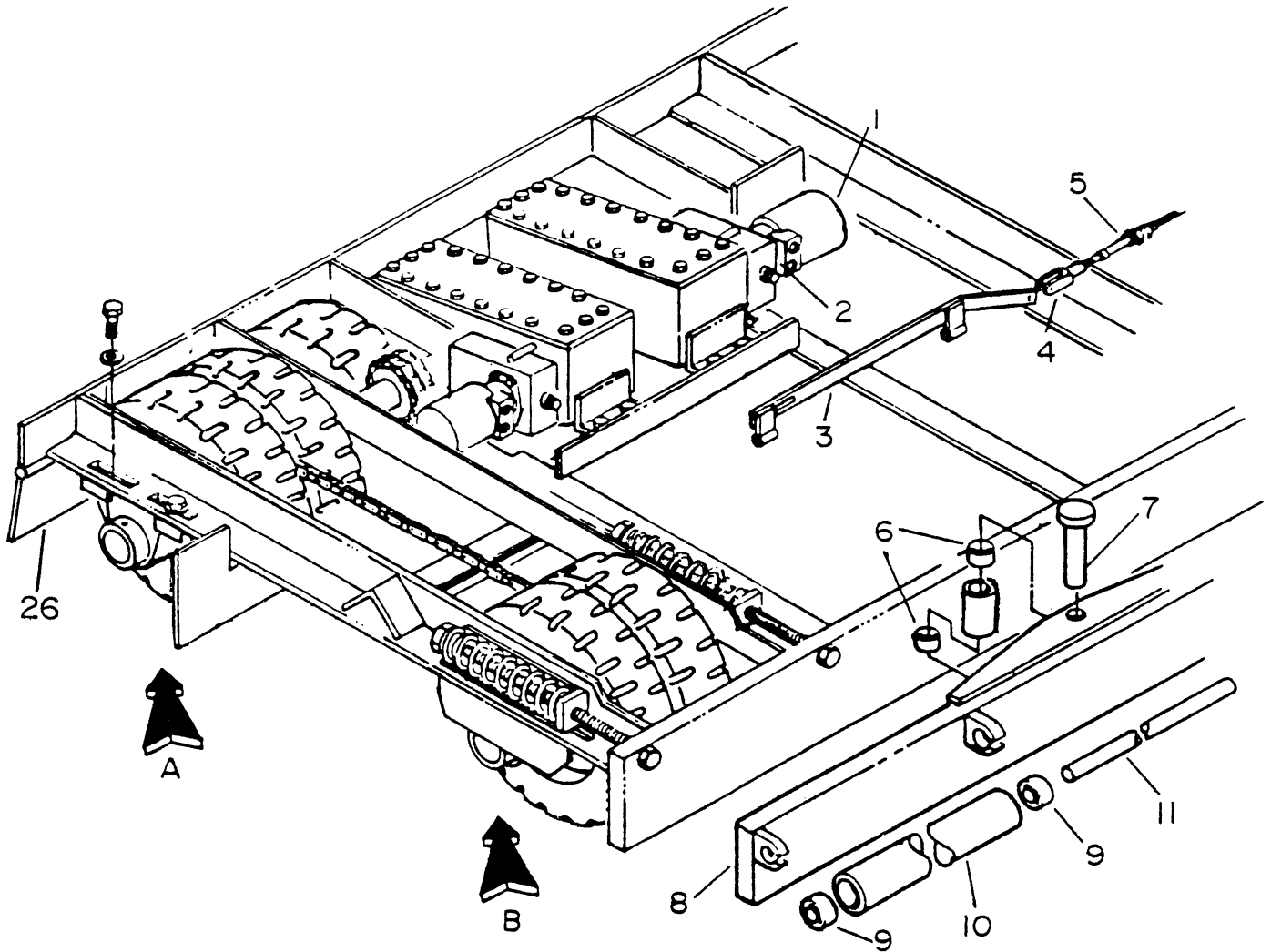

## RUBBER TIRE DRIVE ASSEMBLY

ITEM NO.	PART NUMBER	DESCRIPTION	QTY.
1	810240	Motor, hydraulic drive	2
2	810250	Gasket, drive motor	2
3	810042	Harness, shift	1
4	810050	Clevis, shift 3/8"	1
5	810060	Cable, shift 3" X 86"	1
6	810070	Bushing, oil lite 2"	2
7	810081	Pin, pivot	1
8	810094	Bar, correction angle	1
9	810110	Bearing, roller 1 1/4"	4
10	810102	Roller, bumper	2
11	810122	Shaft, bumper	2
12	810140	Bearing, pillowblock 2 1/4"	4
13	810160	Bushing, 2 1/4"	4
14	820140	Tire, lug 6" x 18" molded	10
15	820150	Sprocket, 80Q22	2
16	820160	Chain, transfer (80)	2
17	820170	Spacer	2
18	810172	Axle, rear 36" x 2 1/4"	2
19	810180	Chain coupling (Double 80)	2
20	810190	Bearing, pillowblock 2"	4
21	820182	Spring, adjustment	4
22	810210	Nut, backup	4
23	810222	Support, adjustment (L or R, specify)	4
24	810232	Bolt, adjustment	4
25	820252	Axle, front drive	2
26	811170	Cutoff, complete 94"	1
27	811172	Prop. Conv. N/S	1
28	810183	Double Master Link - N/S (Double 80)	2
<b>*WHEN ORDERING SEAL KITS GIVE TYPE OF MOTOR AND MODEL # OF MOTOR*</b>			
29	860020	<b><u>Seal Kit For Drive Motor</u></b> Kit, Seal (Drive Motor) (Ross) (MB12) (1 1/4" Spline)	1
30	870312	<b><u>Seal Kit For Cylinder</u></b> Kit, Seal (Cutoff Cylinder) (2 1/2" x 4") (Bobalee)	1

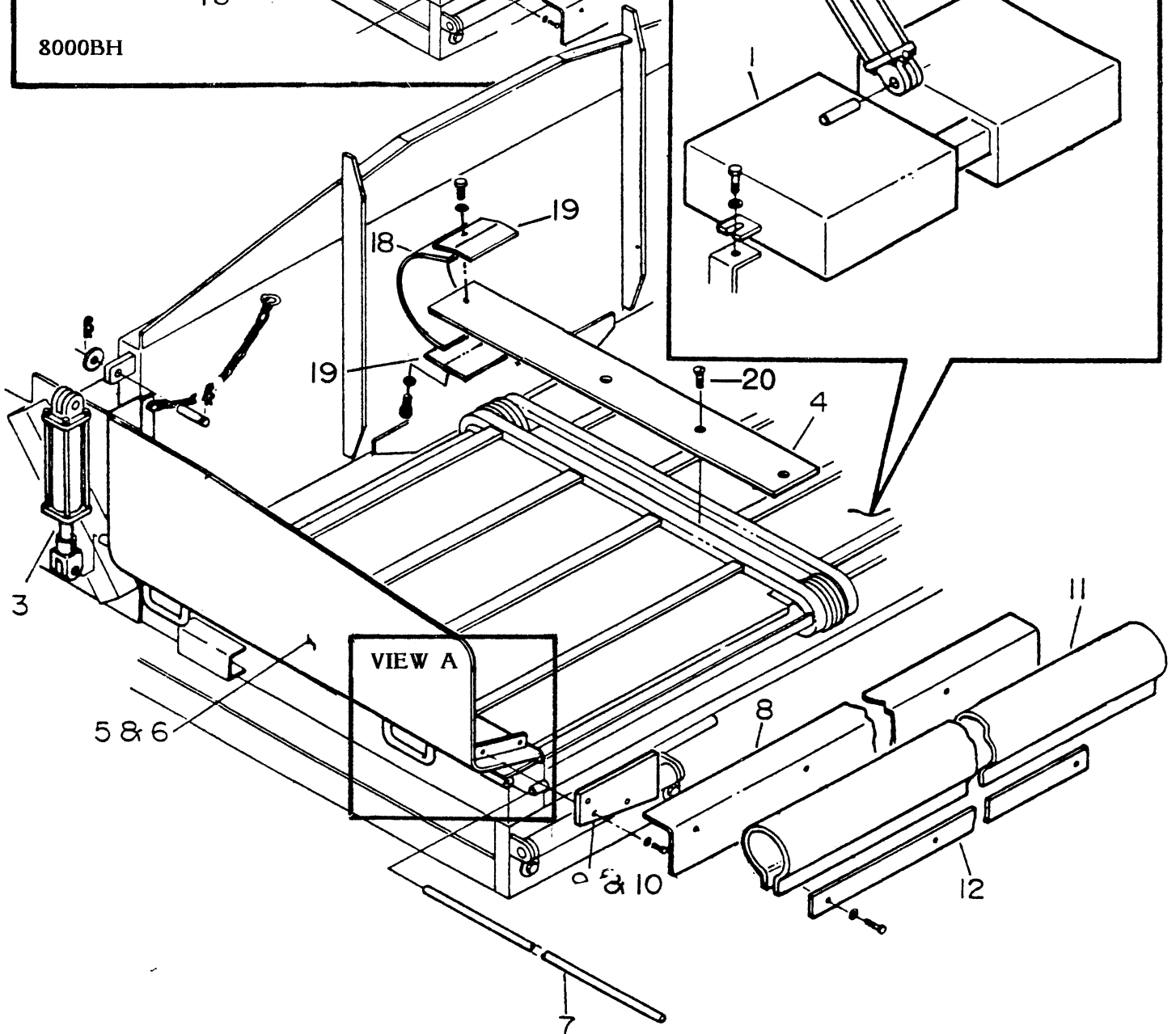
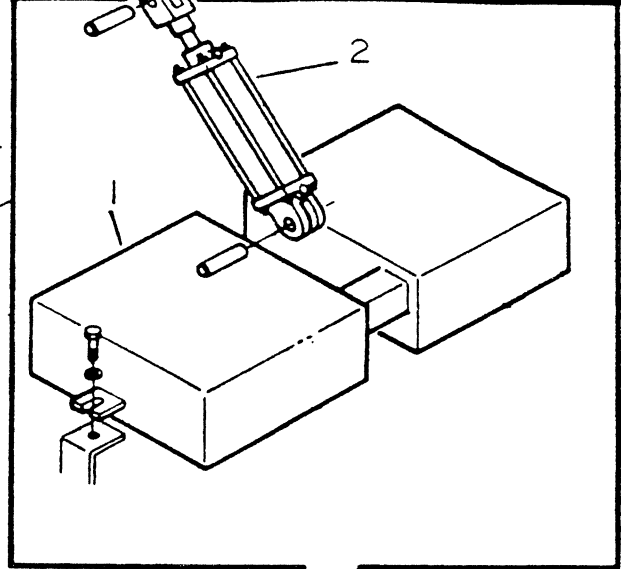
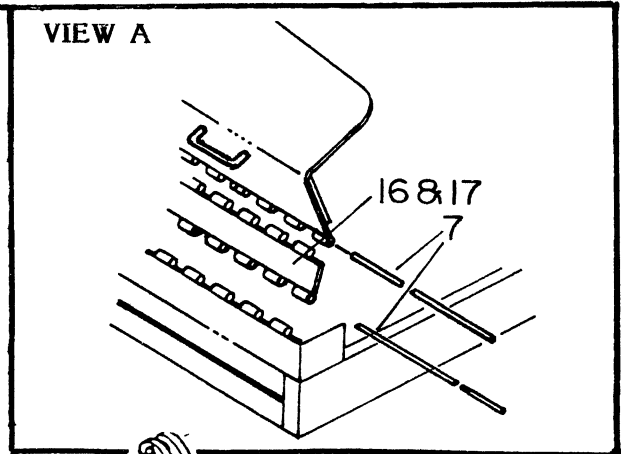
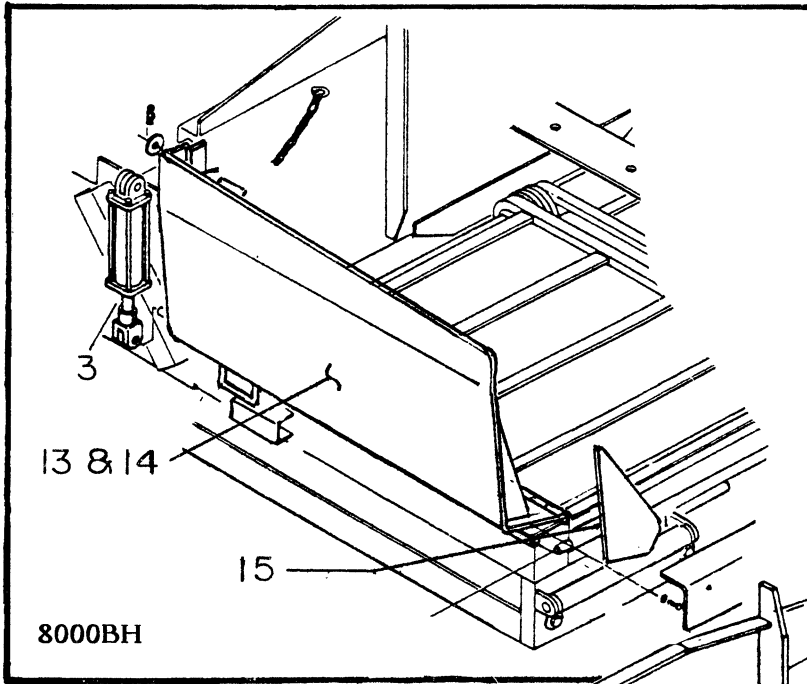

## HOPPER COMPONENTS



ITEM NO.	PART NUMBER	DESCRIPTION	QTY.
1	840017	Tank, hydraulic, (Bottom)	1
2	840020	Cylinder, lift 3" x 12"	1
3	840030	Cylinder, hopper side panel 2" x 7"	2
4	840043	Shield, chain	1
5	840054	Panel, hopper side R/H 9' (Shown)	1
6	840064	Panel, hopper side L/H 9'	1
7	840072	Pin, pivot side panel	2
8	840083	Shield, front support	1
9&10	840090	Shield, front panel (rubber) R/H & L/H	2
11	840110	Shield, front (rubber) (Hopper)	1
12	840122	Reinforcement, shield bar	1
*13	840134	* Panel, hopper side extended R/H 10' (Shown)	1
*14	840144	* Panel, hopper side extended L/H 10'	1
*15	840155	* Shield, Front Panel (Rubber) R/H & L/H	2
16	840156	Hinged Panel Complete for hopper wings R/H (Shown)	1
17	840157	Hinged Panel Complete for hopper wings L/H (N/S)	1
18	840162	Shield, Rubber	1
19	840166	Hold Down	2
20	851134	Screw, Taper	4
21	870313	Kit, Hopper Cylinder	1
		*HIGH DECK ONLY	

**NOTE:** Be sure when ordering part # 850054, Chain Assembly, that they are worn out and not adjusted all the way out. Conveyor 1/2 links, part # 850215, can be installed when chains are stretched out to where they can not be adjusted any more, for longer life.

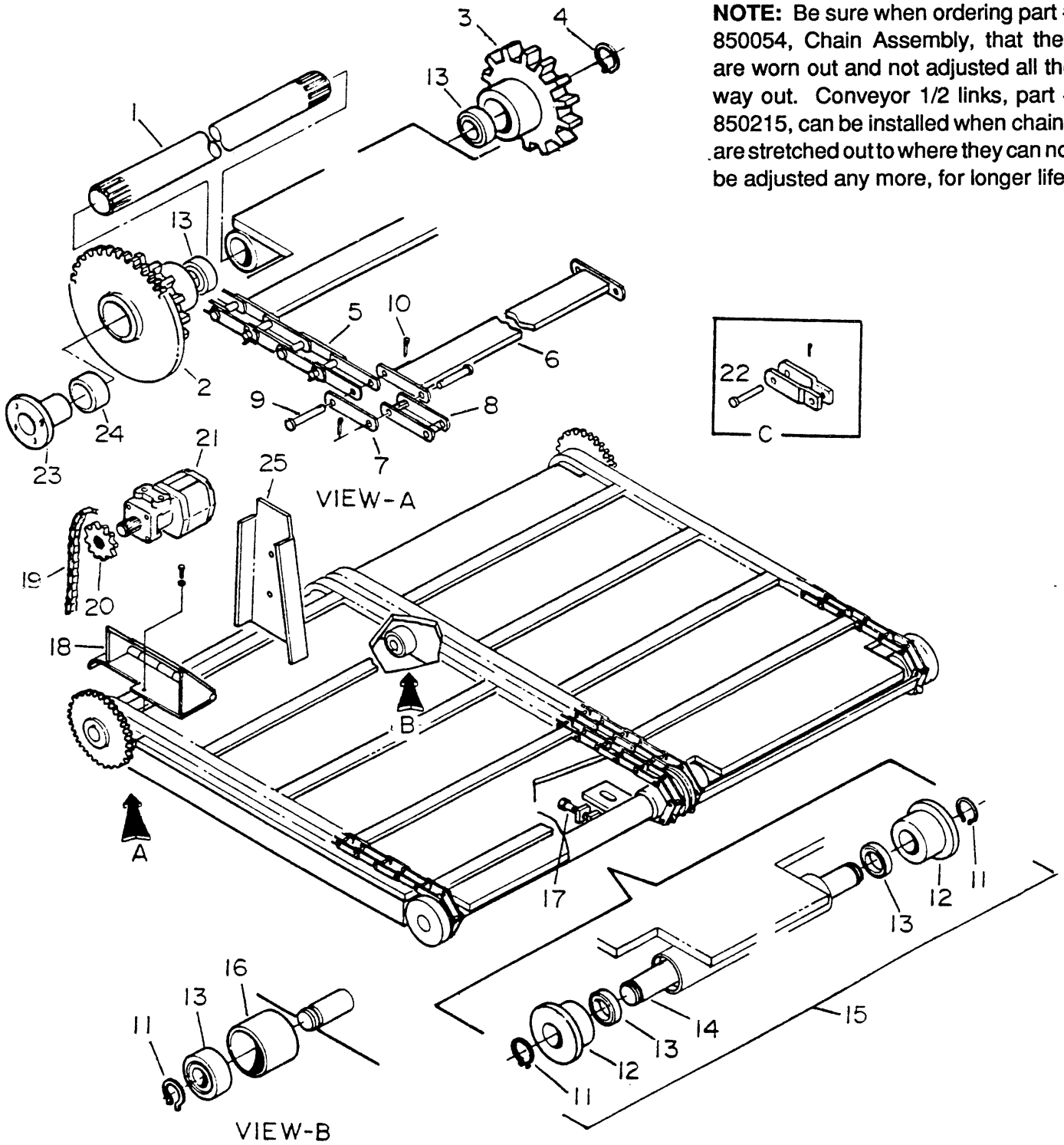

## CONVEYOR DRIVE ASSEMBLY



ITEM NO.	PART NUMBER	DESCRIPTION	QTY.
	850000	CONVEYOR ASSEMBLY COMPLETE	
1	850012	Shaft, drive	2
2	850020	Sprocket, outer drive	2
3	850030	Sprocket, inner drive	2
4	850040	Ring, snap	A/R
5	850054	Chain Assembly	A/R
6	850062	Bar, Conveyor	A/R
7	850070	Link, master C-188	A/R
8	850080	Link, Block (C-188)	A/R
9	850090	Pin, Chain link	A/R
10	850100	Pin, cotter	A/R
11	850040	Ring, snap	A/R
12	850120	Guide, chain	4
13	850130	Bearing	20
14	850142	Shaft, guide	2
15	850152	Chain Guide Assembly (Complete)	1
16	850162	Guide Roller	12
17	850170	Bolt, adjusting	4
18	850183	Deflector, L or R (specify)	2
19	850190	Chain, conveyor drive 60H	2
20	850200	Sprocket 60B10	2
21	850210	Hydraulic motor, conveyor drive	2
22	850215	Conveyor 1/2 Link	4
23	850232	Cap, conveyor pivot	2
24	850240	Bearing, conveyor pivot	2
25	850252	Cover, conveyor drive chain R or L (specify)	2
26	850254	Bottom Cover 1/2 Moon Shaped (N/S)	2
27	851127	Pans, Conveyor (N/S)	2
28	851128	Scraper, Conveyor (N/S)	2
29	851129	Stop, Rubber (Scrape)	2

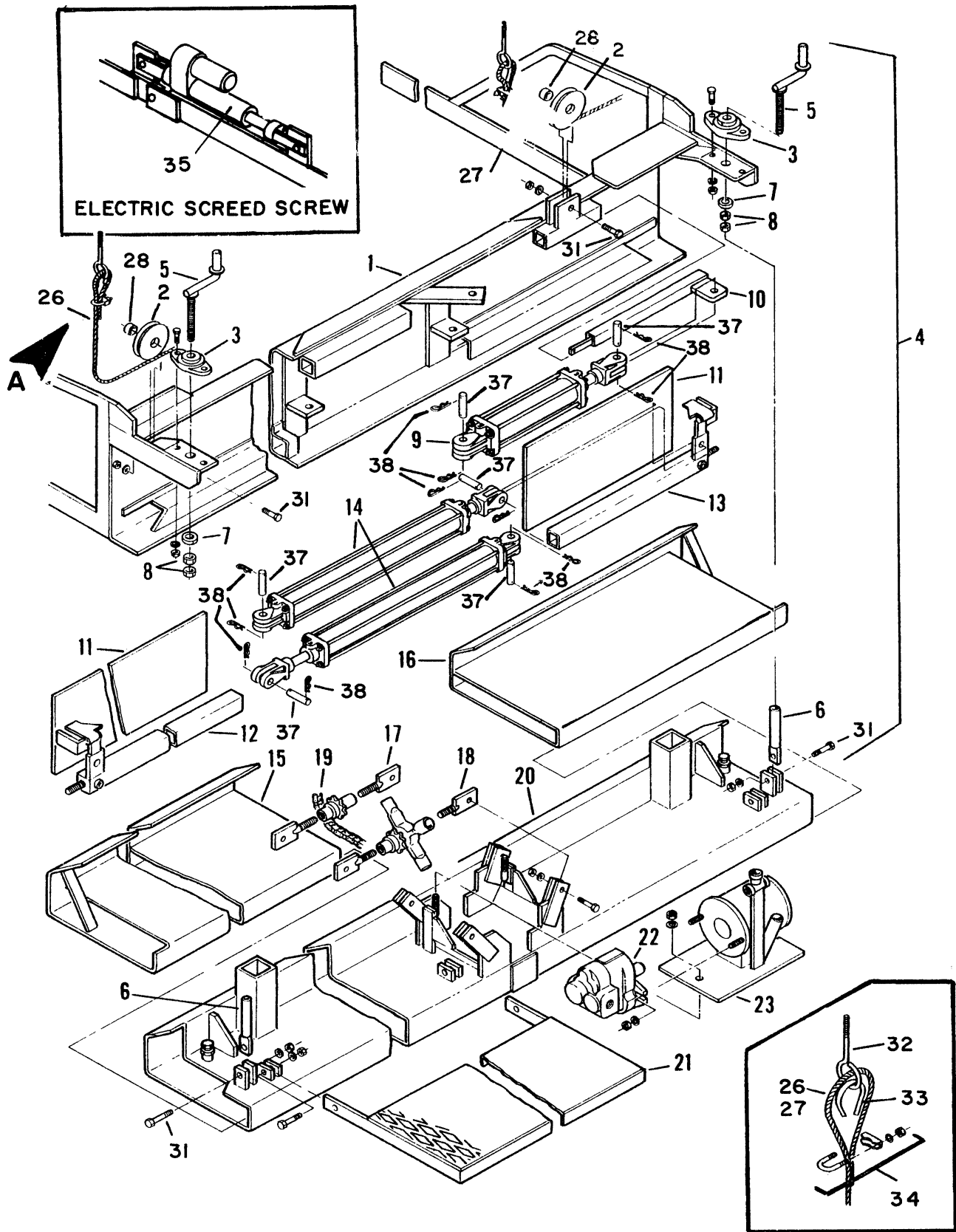

## SCREED BACK ASSEMBLY



ITEM NO.	PART NUMBER	DESCRIPTION	QTY.
1	870016	Screed back assy w/o cyl. (N/S) (Complete)	1
1	870014	SCREED BACK ASSEMBLY (Complete w/Cyl.) 8'	1
2	870020	Pulley, screed	2
3	870030	Bearing, screed flight screw	2
4	870042	Screw Assy., screed flight (Complete)	2
5	870052	Screw handle N/A Must buy Complete Screw Assy.	2
6	870062	Screw receiver N/A Must buy Complete Screw Assy.	2
7	870071	Spacer	2
8	870080	Nut	4
9	870090	Hydraulic cylinder, screed lift 3" x 10" (Old Style)	1
9A	870091	Hydraulic Cylinder, Screed Lift (2 1/2" x 12") (New Style)	1
10	870102	Guide arm, screed lift (Old Style)	1
10A	870103	Guide Arm, Screed Lift (Used with 2 1/2" x 12") (New Style)	1
11	870112	Guide plate, screed extension	2
12	870122	Guide arm, screed extension L/H	1
13	870132	Guide arm, screed extension R/H	1
14	870140	Hydraulic cylinder, screed extension 2 1/2" x 30"	2
15	870153	Inner extension, screed L/H	1
16	870163	Inner extension, screed R/H	1
17	870172	Turnbuckle, crown & valley front	1
18	870182	Turnbuckle, crown & valley rear	1
19	870190	Chain, crown & valley (for turnbuckle) #40	1
20	870204	Screed Complete 8'	1
21	870212	Walkboard 8' (Bolt On)	2
22	870220	Hydraulic motor, screed vibrator	1
23	870232	Eccentric & mounting pad, screed vibrator	1
24	870240	12" Screed extension plates (NS)	A/R
25	870250	6" Screed extension plates (NS)	A/R
26	870260	Cable, screed lift L/H	1
27	870270	Cable, screed lift R/H	1
28	870274	Bearing, Pulley	2
29	870276	Boots, Rubber (Handles) (N/S)	6
30	870278	Screed, Complete 9'0" x 17" (N/S) (Option)	1
31	870279	Bolts, Shoulder (For Pulley)	2
32	870284	Eyebolt, 6"	2
33	870286	Thimble, 3/8"	4
34	870289	U-Bolt, 3/8"	4
35	870302	Screw, Electric	2
36	870303	Walkboard 9' (N/S) (Option)	2
	870304	Walkboard 8' (Weld-On ) (N/S)	2
37	870305	Pins, Cylinders	6
38	870307	Clips, Pins	6

**SCREED BACK ASSEMBLY (Continued)**

ITEM NO.	PART NUMBER	DESCRIPTION	QTY.
39	900742	Screed, Complete Assembly 8000 (9' 0" x 17") W/Cylinders, Inserts and Crown - Valley	1
40	900743	Screed, Complete Assembly 8000 (9' 0" x 17") Includes Inserts and Crown - Valley W/O Cylinders	1

## BASIC SCREED

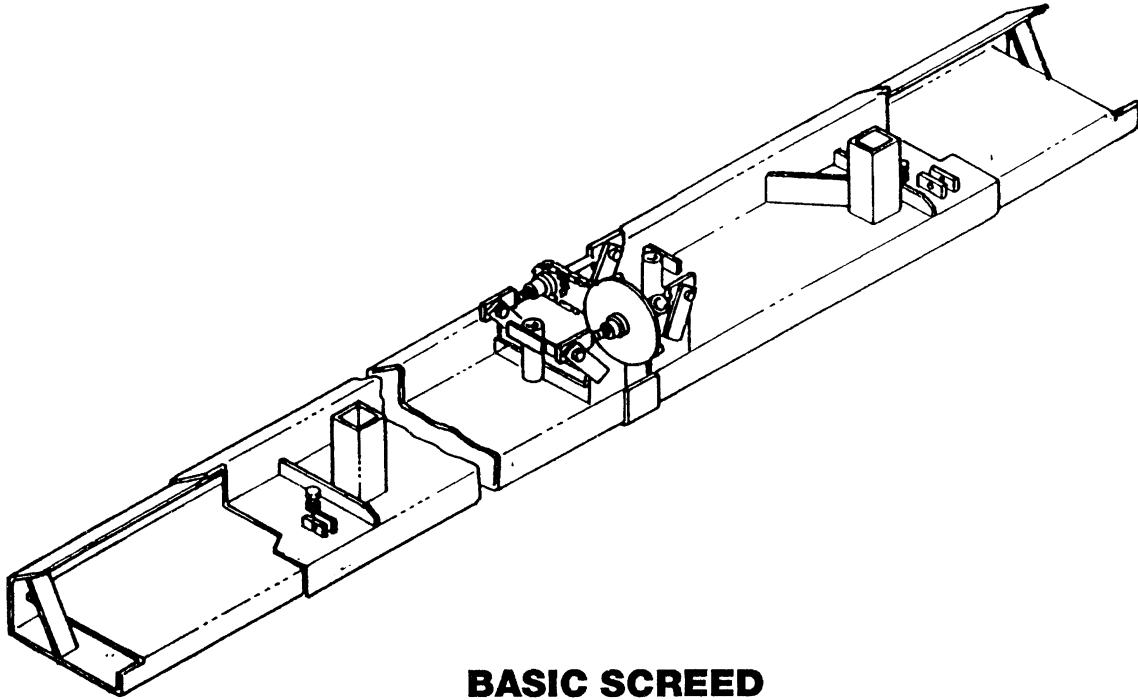

## BASIC SCREED

ITEM NO.	PART NO.	DESCRIPTION	QTY.
* NEED MODEL & SERIAL NUMBER WHEN PLACING ORDER *			
<u>ACCESSORIES</u>			
	870206	8' - 1000B & 8000 Extendable Screed	1
	870205	Kit, Stabilizer (Extendable Screed)	1
	870207	Plate, Wear (Extendable Screed)	1
	870204	Screed (8' 0" x 17") (8000)	1
	870278	Screed (9' 0" x 17") (8000)	1
	870280	Screed (8' 0" x 17") (AR235) (8000)	1
NOTE: SCREEDS CONSIST OF INSERTS AND CROWN & VALLEY			

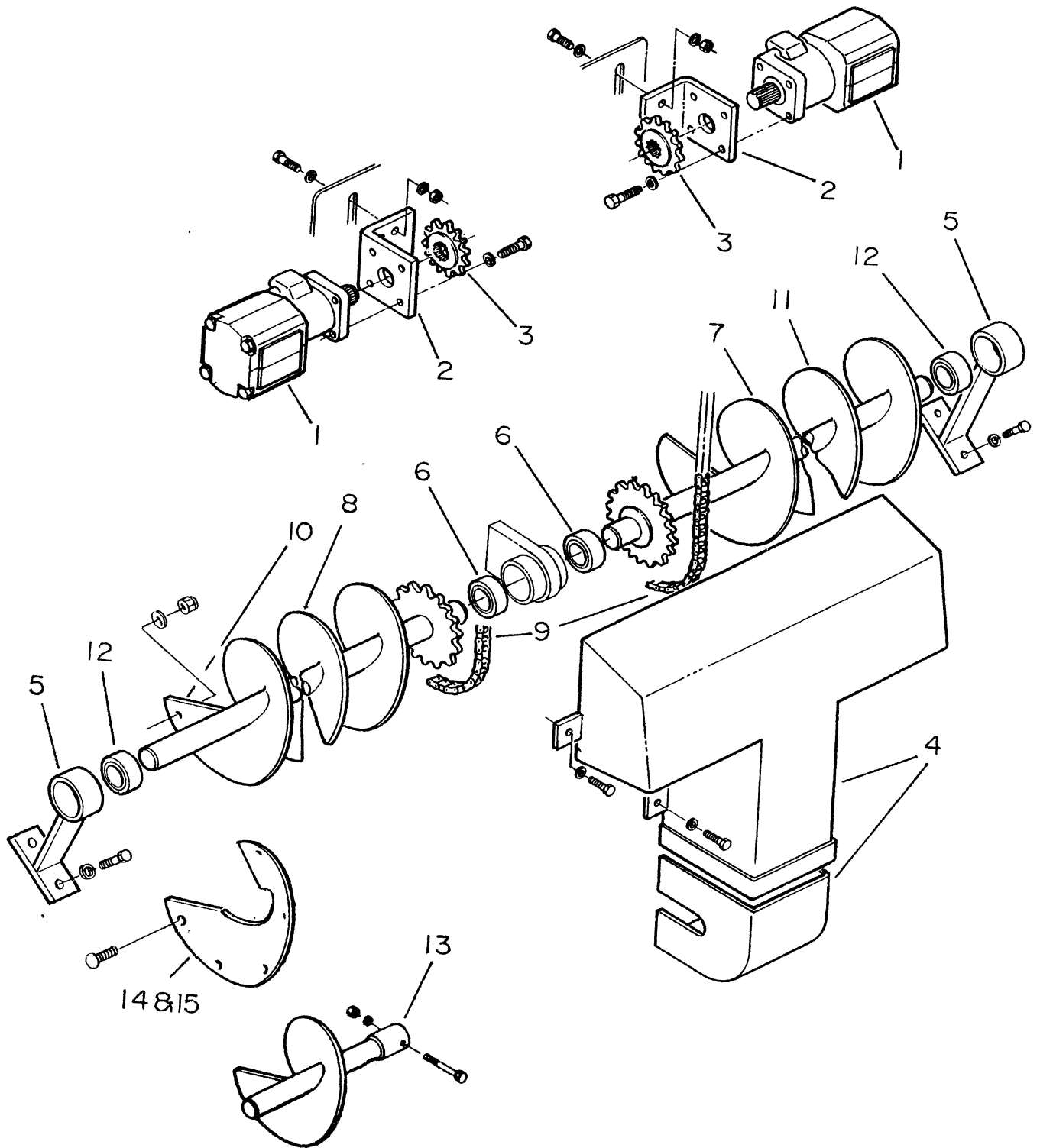

## AUGER ASSEMBLY



ITEM NO.	PART NUMBER	DESCRIPTION	QTY.
1	860010	Motor, hydraulic	2
2	860021	Support, motor	2
3	860030	Sprocket, motor drive (H60B14)	2
4	860043	Cover, auger drive chain	1
5	860051	Mount, auger end	2
6	850130	Bearing, auger inner	2
7	860073	Auger, L/H	1
8	860083	Auger, R/H	1
9	860090	Chain, Auger	2
10	860100	Flight, right auger (Older Model 8000) (Welds On)	A/R
11	860110	Flight, left auger (Older Model 8000) (Welds On)	A/R
12	860121	Spacer	2
13	860132	Auger, extension L/H or R/H (Specify)	1
14	861140	*Wear Plates (Right)	A/R
15	861150	*Wear Plates (Left)	A/R
16	860035	Sprocket, Auger (Welds On) 60A18	2
17	861152	Bolts & Nuts, wear plates (N/S)	A/R
		* 861140 & 861150 Are used only on augers with bolt on Wear Plates. 2 required per flight.	
<b>*WHEN ORDERING SEAL KITS GIVE TYPE OF MOTOR AND MODEL # OF MOTOR*</b>			
<b><u>Seal Kits For Auger Motor</u></b>			
18	860012	Kit, Seal (Auger Motor) (MG) (Newer Type Motors)	1
19	860014	Kit, Seal (Auger Motor) (MAG & MAC) (MAC500001 is used For Both Motors)	1
20	860016	Kit, Seal (Auger Motor) (Char-Lynn) (005 & 006 Use Same Seal Kit) (Older Model Motors)	1
21	860018	Kit, Seal (Auger Motor) (Char-Lynn) (007 & 008 Use Same Seal Kit) (Older Model Motors)	

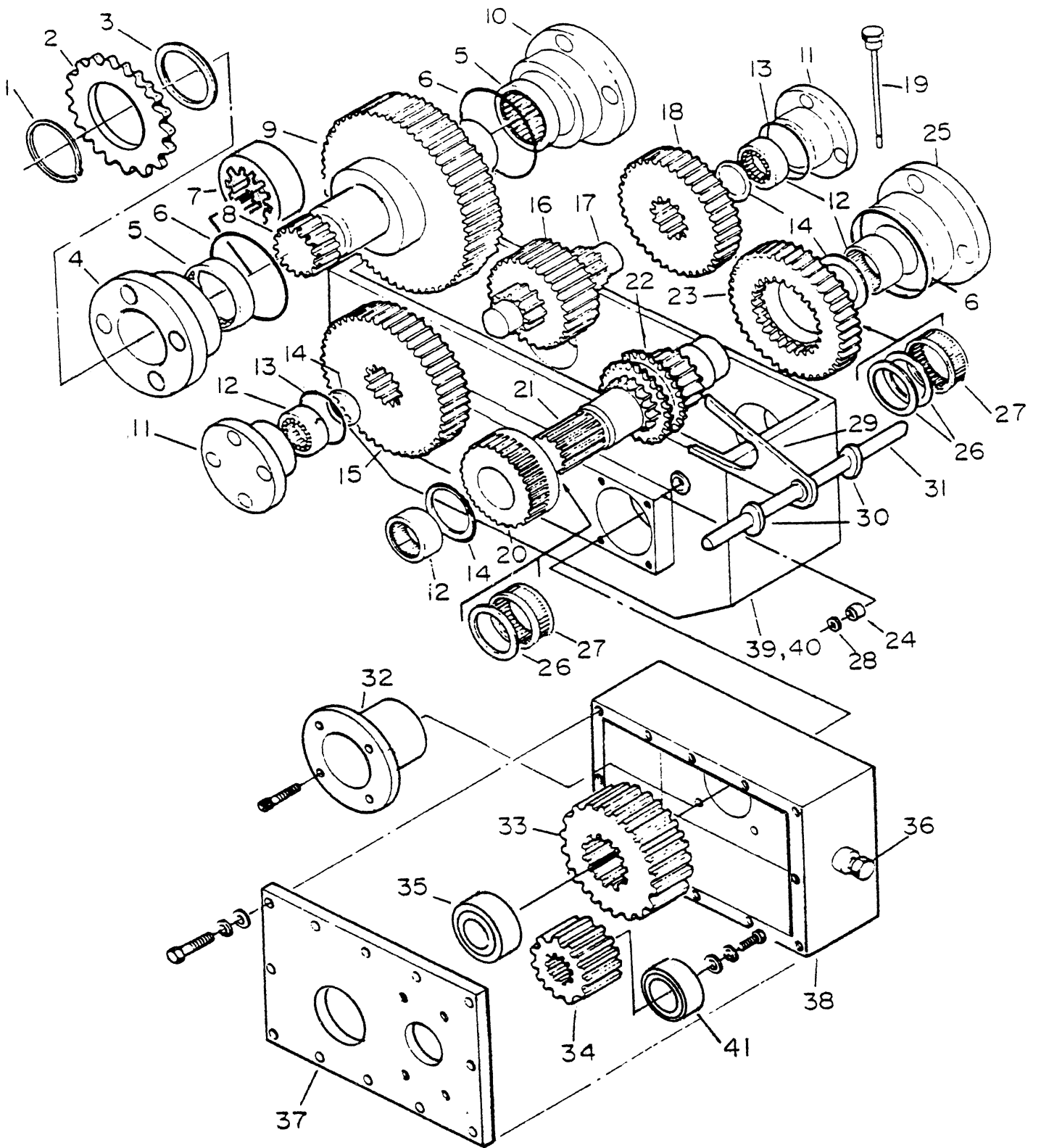

**TRANSMISSION ASSEMBLY**  
**Right Hand Shown (From Serial No. 406 B thru Present)**

ITEM NO.	PART NUMBER	DESCRIPTION	QTY.
	830004	RH Transmission	
	830005	LH Transmission	
1	830010	Snap, ring	1
2	830020	Sprocket, output (80S22)	1
3	830030	Seal, rear	1
4	830041	Cap, rear seal	1
5	830050	Bearing, rear	2
6	830060	O-Ring, front & rear	3
7	831424	Spacer, bull gear	2
8	831082	Shaft, rear	1
9	* 831092	*Gear, bull (Sold in match sets) (Use Part # 831455)	1
10	830101	Cap, plain	1
11	830111	Cap, plain center	2
12	830120	Bearing, front & center	4
13	830130	O-Ring, center cap	2
14	830140	Spacer	A/R
15	* 831151	*Gear, low (center shaft) (Sold in match sets) (Use Part # 831450)	1
16	* 831161	*Gear, intermediate (Sold in match sets) (Use Part # 831455)	1
17	830171	Shaft, center	1
18	* 831181	*Gear, high (center shaft)(Sold in match sets) (Use Part # 831460)	1
19	830191	Stick, dip	1
20	* 831201	*Gear, low (front shaft)(Sold in match sets) (Use Part # 831450)	1
21	831211	Shaft, front	1
22	830221	Gear, clutch	1
23	* 831231	*Gear, high (front shaft)(Sold in match sets) (Use Part # 831460)	1
24	830240	Bushing, Bronze	1
25	830251	Cap, plain	1
26	830260	Spacer, inner gear	3
27	830270	Bearing, inner gear	2
28	830280	Seal, shifter	2
29	830291	Fork, shifter	1
30	830300	Collar, shifter fork	2
31	830311	Shaft, shifter	1
32	830321	Cap, front (bored)	1
33	* 831331	*Gear, input (Sold in match sets) (Use Part # 831465)	1
34	* 831341	*Gear, driver (Sold in match sets) (Use Part # 831465)	1
35	831410	Bearing, input	1
36	830360	Plug	1
37	831371	Plate, side	1
38	830382	Housing, side box	1
39	830393	Housing, main gear box	1
40	830402	Plate, top cover (NS)	1
41	831420	Bearing, (For Driver Gear)	1
42	831421	Allen bolts N/S	
* GROUPS SOLD IN MATCH SETS ONLY			
43	* 831450	Low Gear, (For Centershaft) & Low Gear, (For Frontshaft) Set • Item #15 & #20	
44	* 831455	Bull & Intermediate Gear (set) #9 & #16	
45	* 831460	High Gear, (For Centershaft) & High Gear, (For Frontshaft) Set • Item #18 & #23	
46	* 831465	Input & Driver Gear (Set) Item #33 & #34	

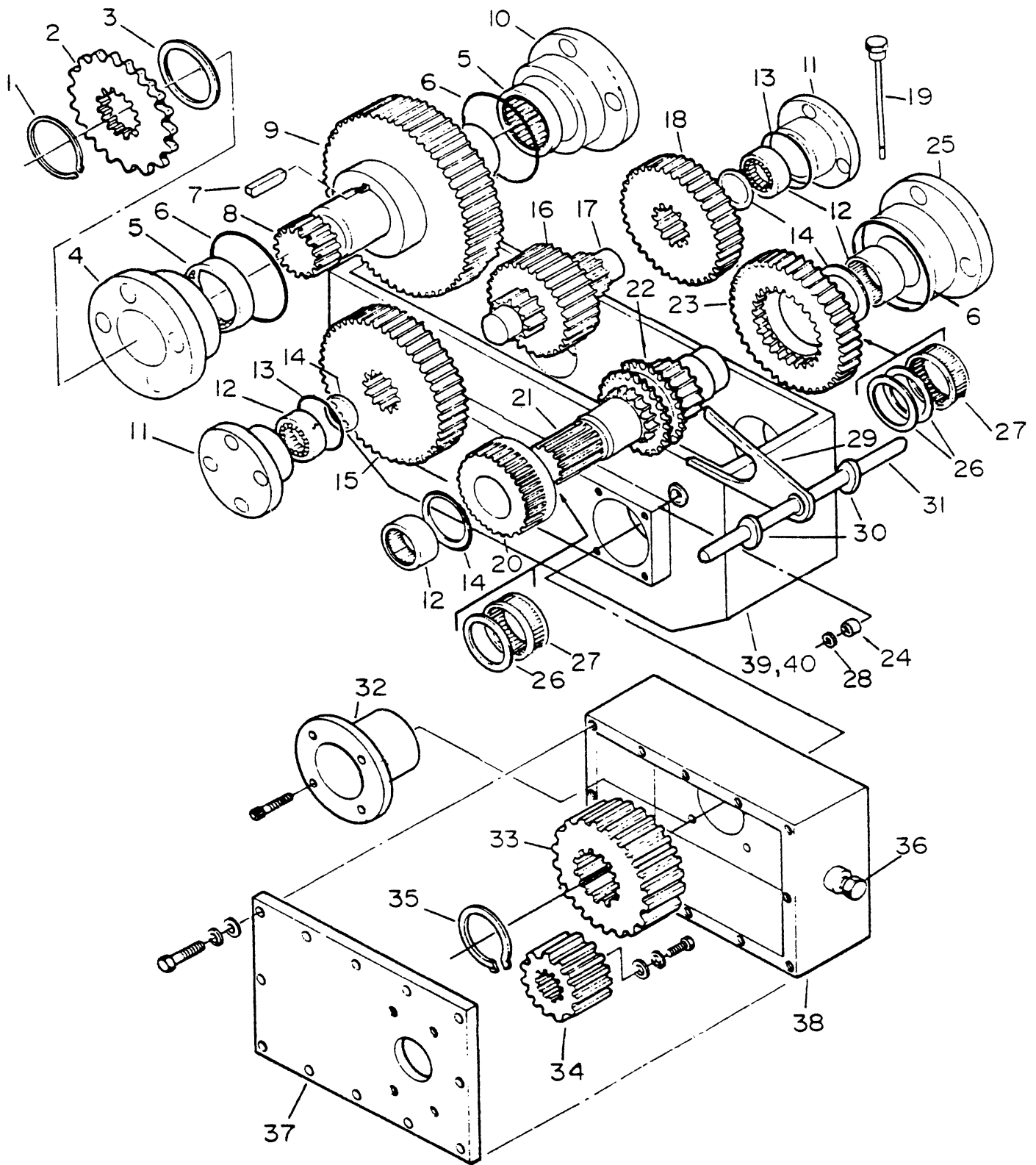

**TRANSMISSION ASSEMBLY**  
**Right Hand Shown (From Serial No. 282 B thru 405 B)**

ITEM NO.	PART NUMBER	DESCRIPTION	QTY.
	830007	RH, Trans.	
	830008	LH, Trans.	
1	830010	Ring, snap	1
2	830020	Sprocket, output (80S22)	1
3	830030	Seal, rear	1
4	830041	Cap, rear seal	1
5	830050	Bearing, rear	2
6	830060	O-Ring, rear	3
7	830071	Key, 1/2 harden	2
8	830082	Shaft, rear	1
9	* 830092	*Gear, bull (Sold in match sets) (Use Part # 831470)	1
10	830101	Cap, plain (rear)	1
11	830111	Cap, plain center	2
12	830120	Bearing, Front & center	4
13	830130	O-Ring center cap	2
14	830140	Spacer, center	A/R
15	* 830151	*Gear, low (center shaft) (Sold in match sets) (Use Part # 830450))	1
16	* 830161	*Gear, intermediate (Sold in match sets) (Use Part # 831470)	1
17	830171	Shaft, center	1
18	* 830181	*Gear, high (center shaft)(Sold in match sets) (Use Part # 830460)	1
19	830191	Stick, dip	1
20	* 830201	*Gear, low (front shaft)(Sold in match sets) (Use Part # 830450)	1
21	830211	Shaft, front	1
22	830221	Gear, clutch	1
23	* 830231	*Gear, high (front shaft)(Sold in match sets) (Use Part # 830460)	1
24	830240	Bronze Bushing	1
25	830251	Cap, plain (front)	3
26	830260	Spacer, inner gear	3
27	830270	Bearing, inner gear	2
28	830280	Seal, shifter	2
29	830291	Fork, shifter	1
30	830300	Collar, shifter fork	2
31	830311	Shaft, shifter	1
32	830321	Cap, front (bored)	1
33	* 830331	*Gear, input (Sold in match sets) (Use Part # 830465)	1
34	* 830341	*Gear, driver (Sold in match sets) (Use Part # 830465)	1
35	830350	Ring, snap	1
36	830360	Plug	1
37	830371	Plate, side	1
38	830382	Housing, side box	1
39	830393	Housing, main gear box	1
40	830402	Plate, top cover (not shown)	1
41	831420	Bearing, (For Driver Gear)	1
42	831421	Allen bolts N/S	
* GROUPS SOLD IN MATCH SETS ONLY			
43	* 830450	Low Gear, (For Centershaft) & Low Gear, (For Frontshaft) Set • Item #15 & #20	
44	* 830455	Bull & Intermediate Gear (Set) Item #9 & #16	
45	* 830460	High Gear, (For Centershaft) & High Gear, (For Frontshaft) Set • Item #18 & #23	
46	* 830465	Input & Driver Gear (Set) Item #33 & #34	
47	*831470	*Kit* Heavy Duty Bull And Intermediate Gear, Rear Shaft & Spacer Set - Item #6,7 & 14. (Note: When replacing these items, do not install snap ring on rear shaft, on Models that have the chain going down to gearbox.)	

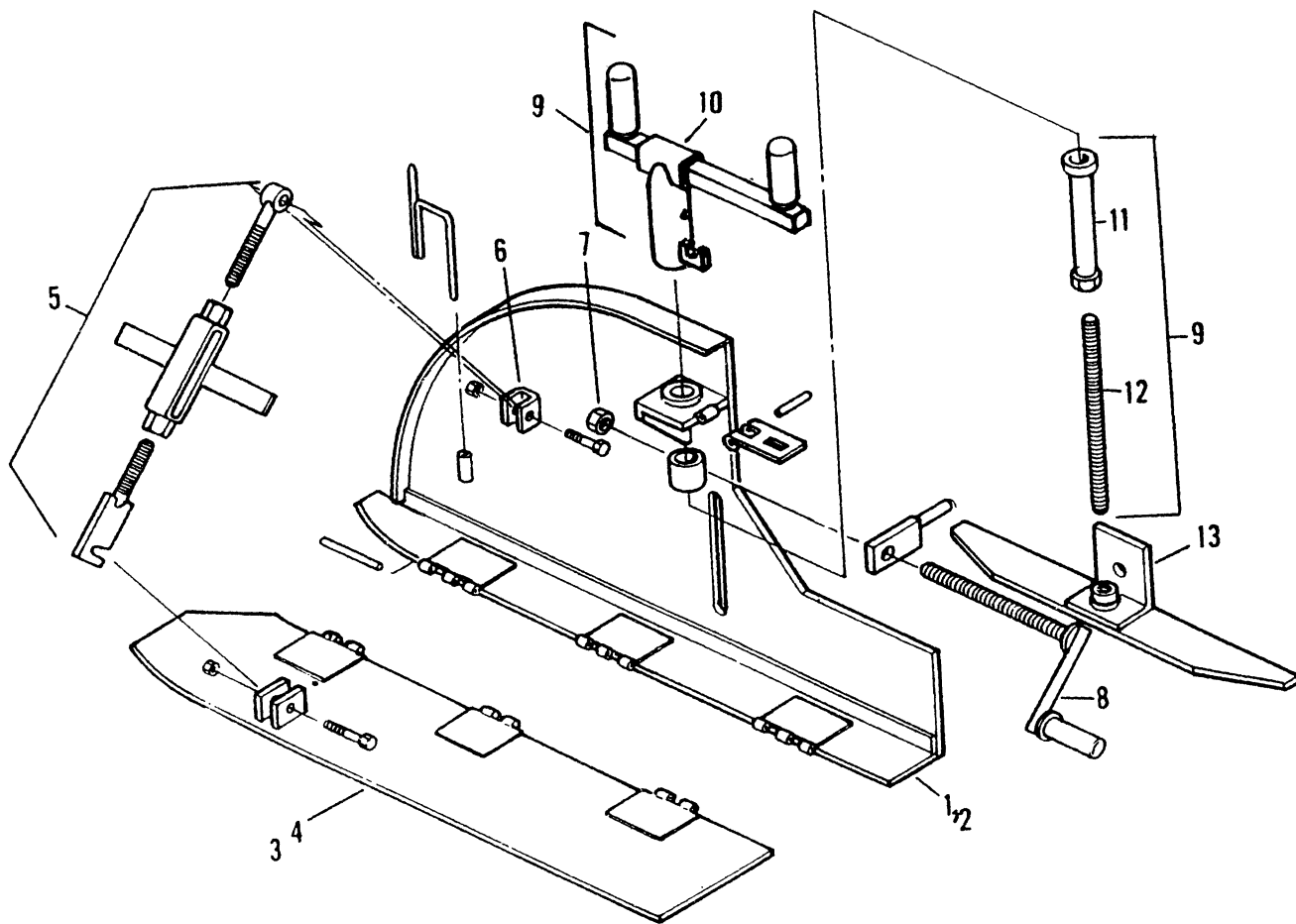

# JOINTER ASSEMBLY



ITEM NO.	PART NO.	DESCRIPTION	QTY.
	890001	Jointer Assy. cpt., L/H (Shown)	1
	890002	Jointer Assy. cpt., R/H	1
1	890011	Jointer, Guide Support, L/H	1
2	890021	Jointer, Guide Support, R/H	1
3	890031	Jointer Guide, L/H	1
4	890041	Jointer Guide, R/H	1
5	890051	Turnbuckle Assy.	2
6	890060	Bracket	2
7	890070	Nut	2
8	890081	Tilt Screw, Jointer	2
9	890092	Depth Screw (Complete)	2
10	890102	Handle, Depth Screw sliding type (Use Part #890092)	N/A
11	890111	Receiver, Depth Screw (Use Part #890092)	N/A
12	890121	Screw	1
13	890132	Bracket, Depth Screw control	1
14	870276	Boot Rubber (handles) (N/S)	A/R

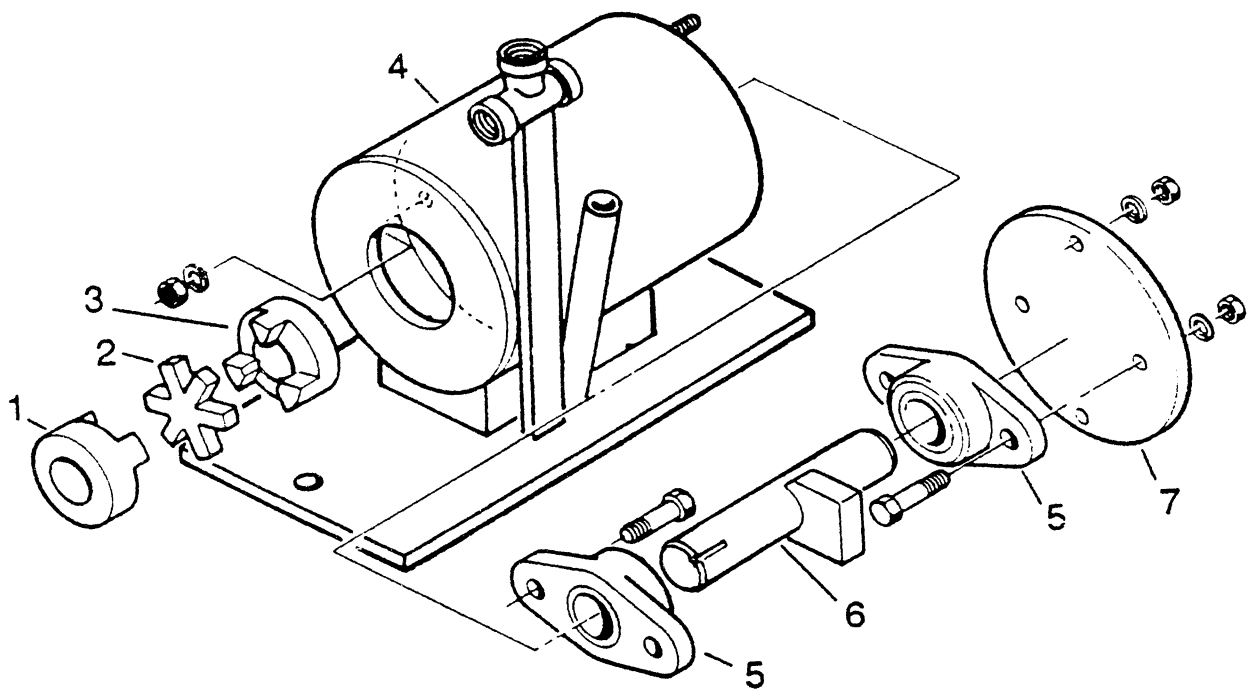

## **VIBRATOR ASSEMBLY**

ITEM NO.	PART NUMBER	DESCRIPTION	QTY.
1	280030	Coupling, Vibrator Motor	1
2	280040	Insert, Coupling	1
3	880030	Coupling, Vibrator Eccentric	1
4	880042	Housing, Vibrator Eccentric	1
5	250150	Bearing	2
6	880062	Shaft, Vibrator Eccentric	1
7	880071	Plate, Vibrator Housing	1

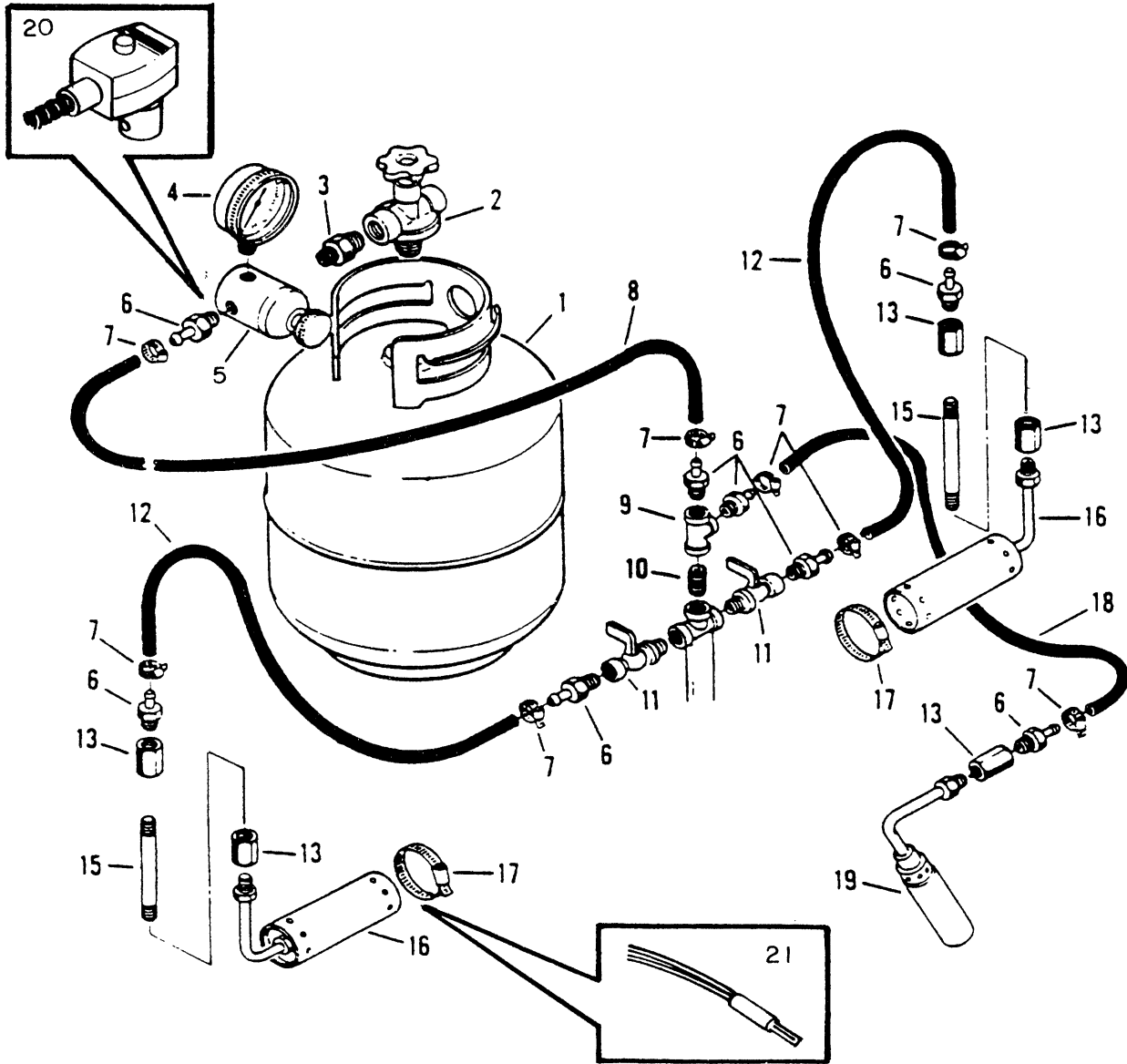

**PROPANE HEATER ASSEMBLY  
& AUTOMATIC IGNITORS**



<b>ITEM NO.</b>	<b>PART NO.</b>	<b>DESCRIPTION</b>	<b>QTY.</b>
1	230010	Tank, Propane (Complete)	1
2	230020	Valve, Propane Tank (N/A Comes With Tank)	N/A
3	230030	Adaptor, P.O.L. (N/A Comes With Regulator)	N/A
4	230110	Gauge, Gas Pressure	1
5	230100	Regulator, Propane (Complete)	1
6	230150	Adaptor, Hose to Pipe	8
7	230160	Clamp, Hose	8
8	230000	Hose	1
9	230080	Tee, Pipe	1
10	230140	Nipple, Pipe	1
11	230070	Valve, Cutoff	3
12	230000	Hose	1
13	230170	Adaptor, Pipe to Burner Nozzle	6
14			
15	230999	Nipple, Pipe	3
16	230191	Burner Nozzle, Screed (BP6)	2
17	230240	Clamp, Nozzle Holder	2
18	230000	Hose	1
19	230200	Burner Nozzle, Ignitor (BP4)	1
<b><u>AUTOMATIC IGNITORS (BURNERS)</u></b>			
20	230022	Valve, Electric	1
21	230024	Heaters, 12 VDC	2
22	900122	Button, Preheat (N/S)	1
23	500040	Switch, Toggle (N/S)	1
24	910025	Burner, Screed (BP5) (N/S) (Older Model 500 & 800 Pavers) (N/S)	2

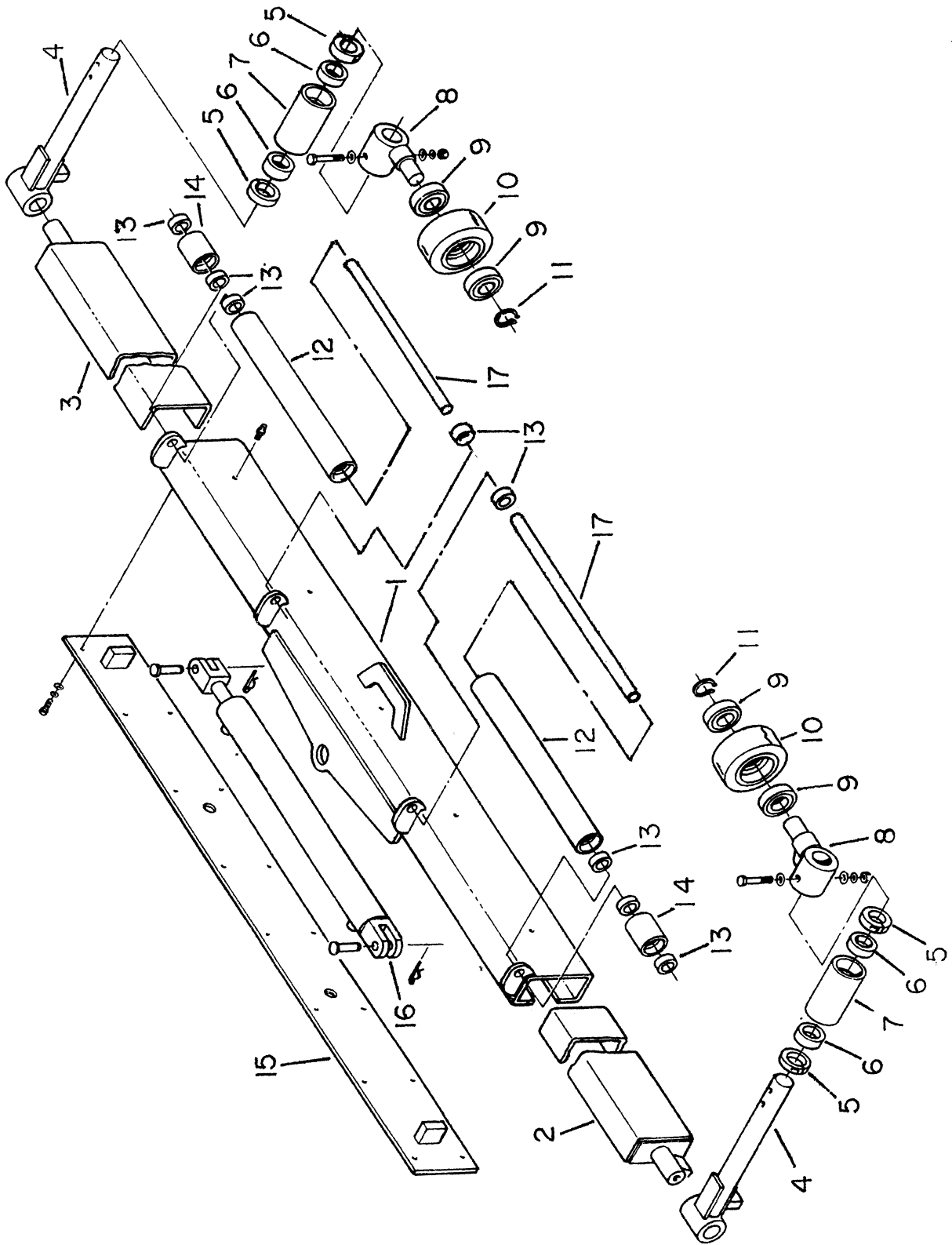

## **TRUCK HITCH ASSEMBLY**

ITEM NO.	PART NUMBER	DESCRIPTION	QTY.
	930010	TRUCK HITCH ASSEMBLY	1
1	930015	Support, pivot bar	1
2	930020	Arm Extension, R/H	1
3	930025	Arm Extension, L/H	1
4	930030	Guide, wheel pivot arm	2
5	930035	Collar, lock	4
6	810070	Bushing, tire roller	4
7	930040	Roller	2
8	930045	Axle, guide wheel	2
9	930050	Bearing, guide wheel	4
10	930055	Wheel, guide	2
11	850040	Ring, snap	2
12	810102	Roller, bumper	2
13	810110	Bearing, roller	8
14	930060	Roller Extension, bumper	2
15	930065	Cover, back panel	1
16	930070	Cylinder, arm extension	1
17	930075	Shaft, bumper roller	2

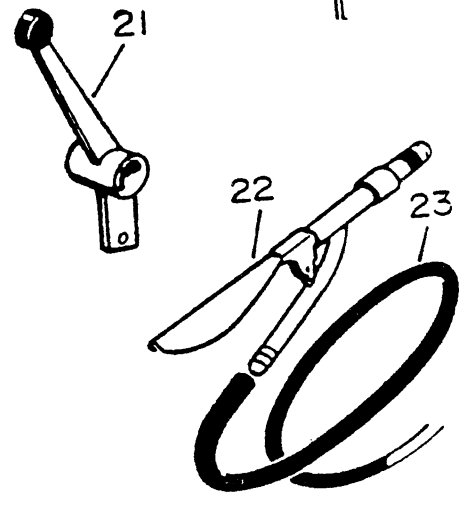
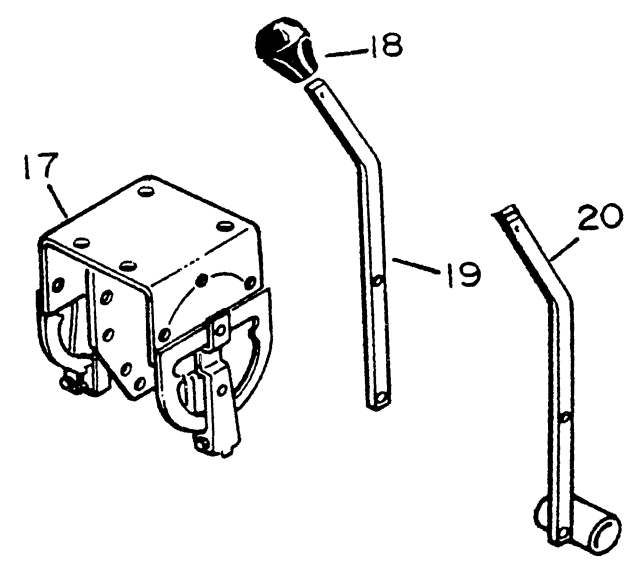
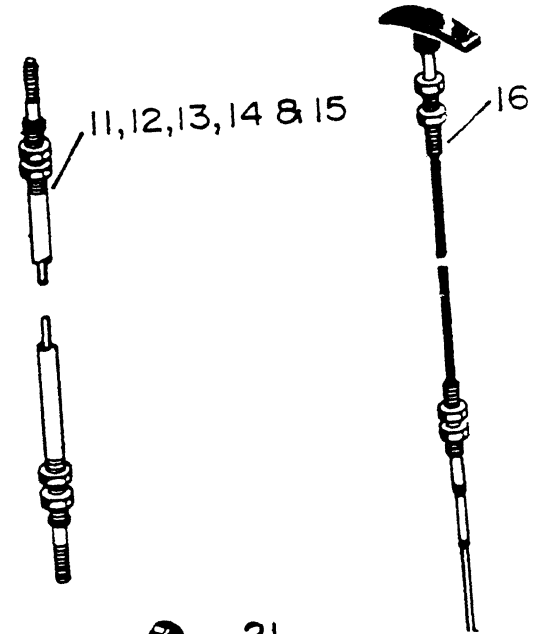
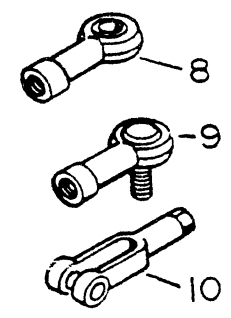
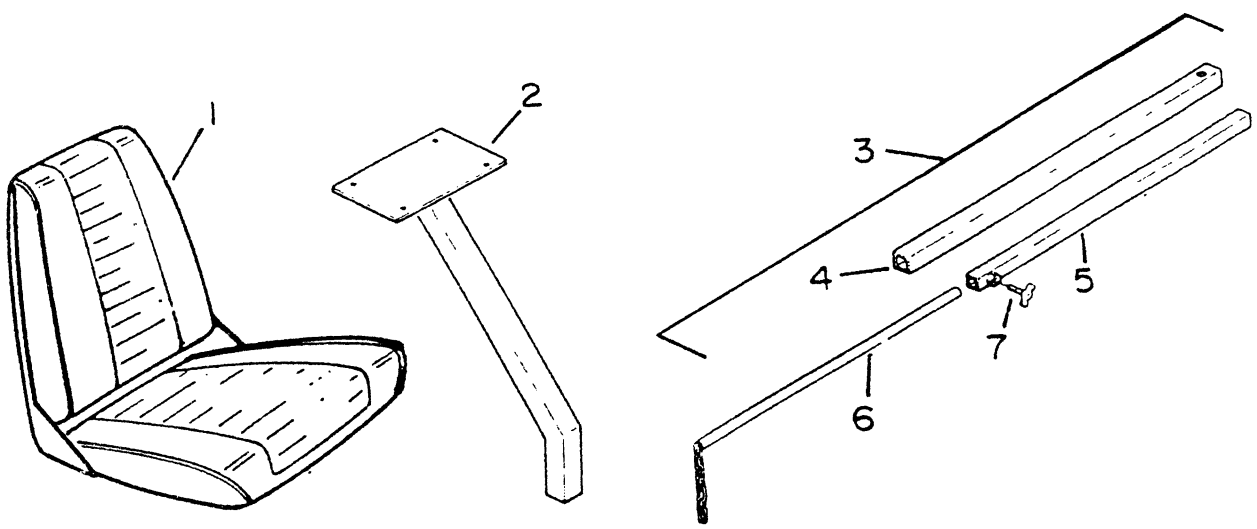

## SPECIAL COMPONENTS

ITEM NO.	PART NUMBER	DESCRIPTION	QTY.
1	360010	Seat	1
2	920022	Support, seat	1
2B	920024	Support, seat (HD) N/S	1
3	920032	Guide bar assembly	1
4	920041	Bar, guide (outer)	1
5	920051	Bar, guide (inner)	1
6	920061	Bar, guide (rod)	1
7	920070	Lock, guide bar adjuster	1
8	920080	Rodend, spherical	4
9	920090	Rodend, spherical, with stud	2
10	350050	Clevis, yoke 1/4"	4
11	920110	Cable, R/H drive (116 x 5) Quadco	1
12	920120	Cable, pump (104 x 3)	1
13	920130	Cable, Extension (123 x 3)	1
14	920140	Cable, auger (116 x 3) Drive Cable (L/B Controls)	1
15	920150	Cable, Throttle (Deutz)	1
16	920160	Cable, throttle (Hatz)	1
17	920172	Control, quadco (R or L- specify)	@1
18	920180	Knob	4
19	920192	Lever, quadco (R or L - specify)	@1
20	920202	Lever, right hand steering, R or L - specify	@1
21	920210	Lever, right hand auger and extension	2
22	920220	Handle, spray down	1
23	920000	Hose	1
24	920225	Knob, Round (L/B) N/S	4
25	920228	Handles, Dr. (L/H) (L/B) N/S	2
26	920230	Handles, Dr. (R/H) (L/B) N/S	2
27	901210A	Tips, Spray Handle	1

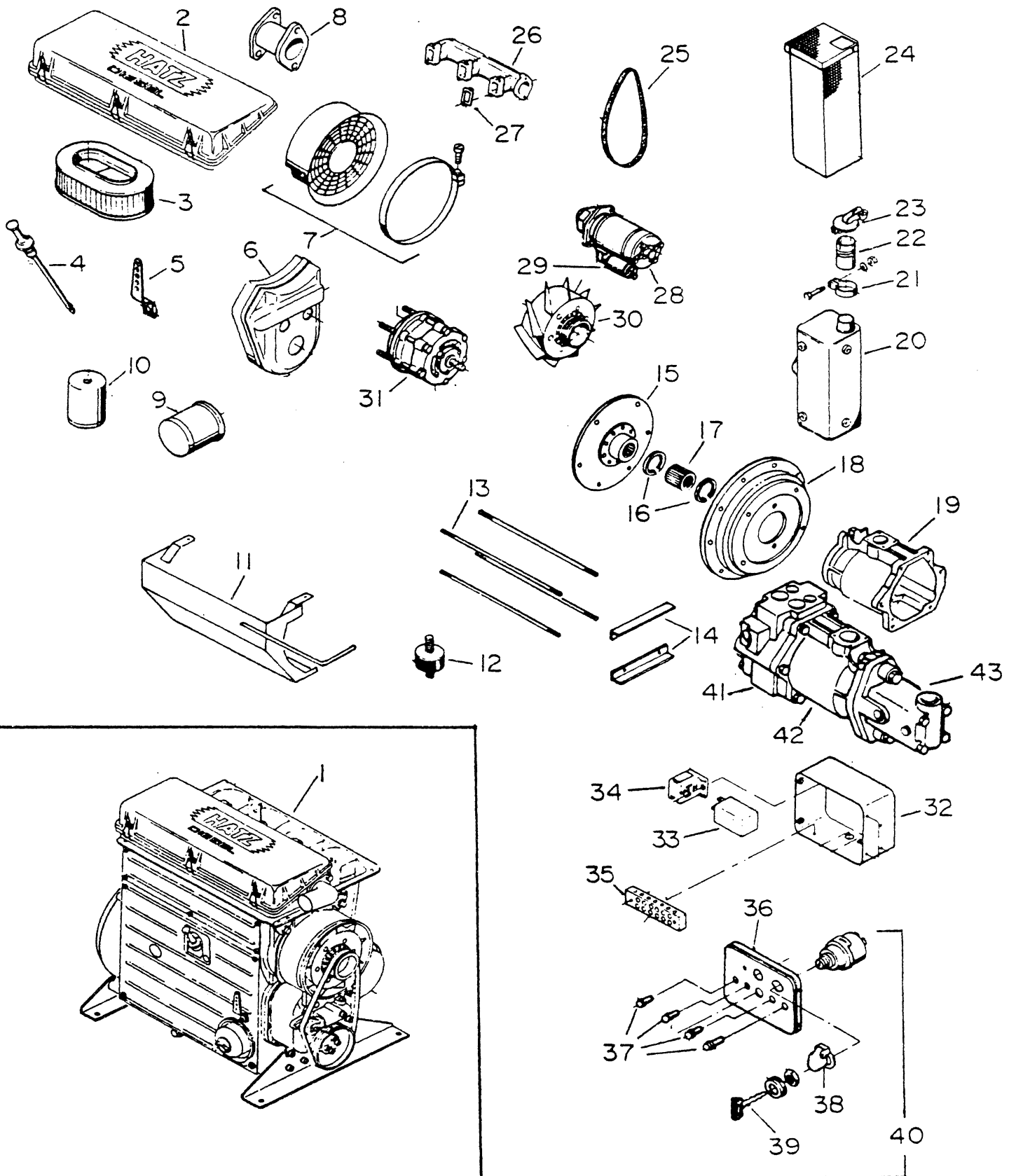

## ENGINE AND PUMP COMPONENTS

ITEM NO.	PART NUMBER	DESCRIPTION	QTY.
1	320000	Engine, Hatz diesel ( )	1
2	320100	Cover, filter-Specify 2,3, or 4 cyl.	1
3	310060	Cleaner, air	1
4	320110	Stick, dip	1
5	320120	Lever, throttle	1
6	320080	Shroud, lower belt	1
7	320070	Shroud, upper belt	1
8	320131	Pipe, exhaust extension	1
9	310070	Filter, oil	1
10	310080	Filter, fuel	1
11	320112	Shield, heat	1
12	320140	Mount, engine	4
13	320150	Brace, pump	4
14	320161	Brace, pump alignment	1
15	320170	Coupling, inner drive pump	1
16	320180	Snap ring	2
17	320190	Coupling, pump shaft	1
18	320200	Cover, pump plate	1
19	320210	Housing, pump	1
20	320040	Muffler	1
21	320220	Clamp, muffler	1
22	320230	Pipe, muffler extension	1
23	320010	Cap, rain	1
24	320240	Shield, muffler	1
25	320090	Belt, blower	1
26	320250	Manifold, exhaust - specify 2, 3, or 4 cyl.	1
27	320260	Gasket, manifold	4
28	320270	Starter	1
29	320280	Solenoid, starter	1
30	320290	Blower	1
31	320300	Alternator, Hatz	1
32	320310	Housing, control box	1
33	320320	Relay	
34	320330	Holder, relay	
35	320340	Terminal	1
36	320350	Cover, control box	
37	320360	Bulbs, indicator	1
38	320370	Cover, ignition	1
39	320380	Key (new style keys-Teeth on both Sides)	1
40	320390	Ignition Assembly	1
41	320400	Transmission cpt.	1
42	320405	Pump section, (variable volume)	2
43	320410	Double vane pump	1
44	320362	Complete Idiot light	
45	320376	Hatz key, old style-teeth on one side #285 or #14610	
46	320426	Diode, switch N/S	
47	320416	Transmission (cpt.) Sunstrand N/S	
48	320418	Pump, Section (Sunstrand N/S)	
49	320420	Pump, Double Vane (Sunstrand N/S)	
50	320422	Muffler, Silent Pack (Hatz) N/S	
51	320424	Rain Cap, Silent Pack (Hatz) N/S	

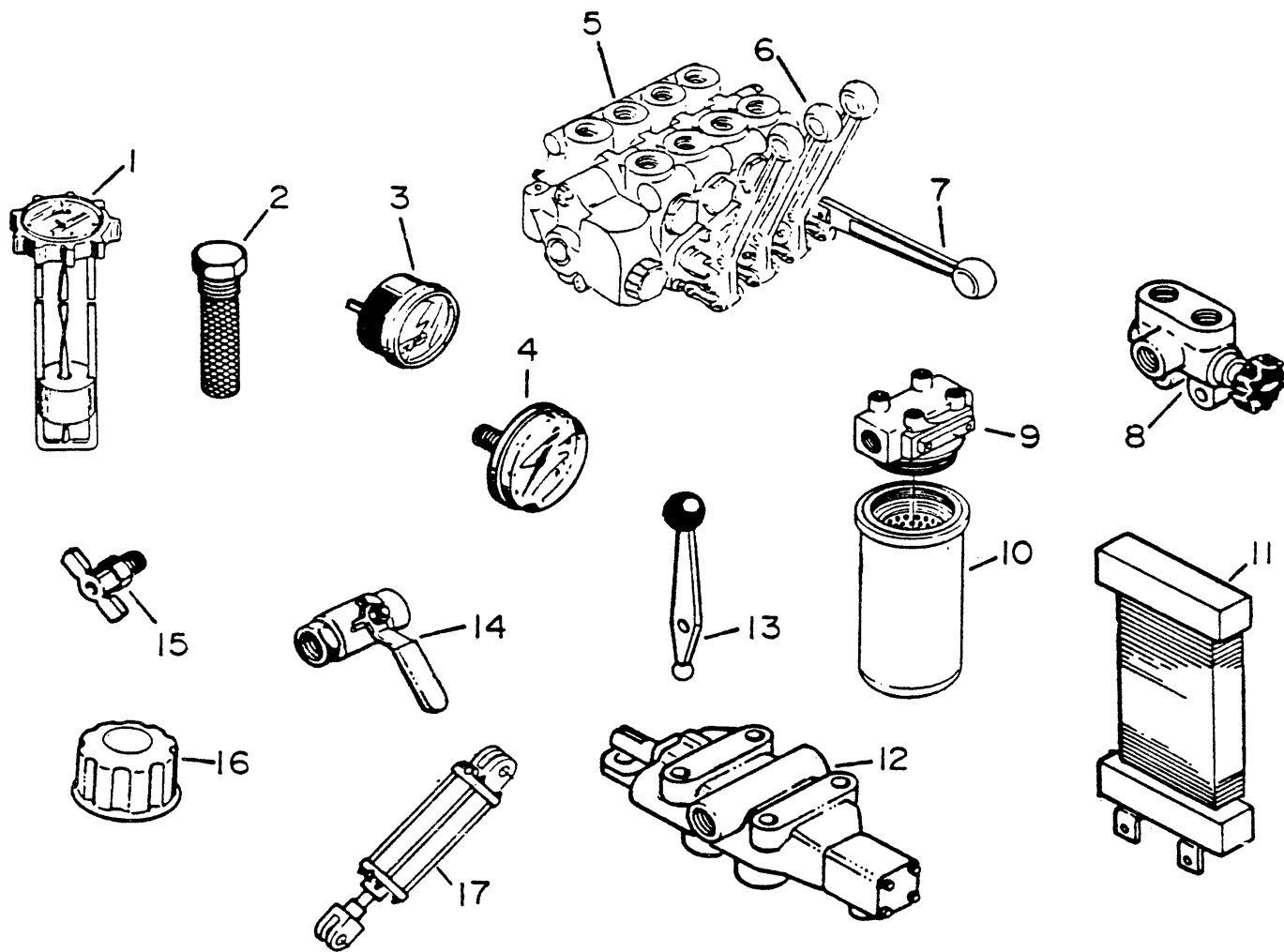

## **HYDRAULIC COMPONENTS**

ITEM NO.	PART NUMBER	DESCRIPTION	QTY.
1	910010	Gauge, Fuel	1
2	910020	Strainer, Suction	1
3	330030	Gauge, Hyd. Pressure	
4	330040	Gauge, Temperature	1
5	910050	Valve, Series	A/R
5A	910059	Seal Kit, Spool	
5B	910062	Seal Kit, Section	
6	910060	Handle, Vertical	A/R
7	910070	Handle, Horizontal	A/R
8	910080	Valve, Selector	1
8A	910085	Seal, Kit Selector	
9	290010	Filter, Head (Must buy complete assembly) (When ordering this part use part #290025)	1
10	290030	Element, Filter	1
11	910110	Cooler, Oil	1
12	910120	Valve, Monoblock	1
12A	910126	Seal Kit, 400 Valve	
13	910130	Lever	1
14	910140	Valve, Vibrator Ball	1
15	910150	Petcock	1
16	910160	Cap, Breather	1
17	910170	Cylinder, Cutoff 2-1/2" x 4" (8000 Rubber Tire & Elites & 1000B Models)	2
18	910172	Cylinder, Cutoff (Torque Hub- N/S) 2-1/2" x 4" (8000 & 1000 with Torque Hub)	
19	910176	Relief, Sidewing (N/S)	
20	290025	Assembly Complete Hydraulic Filter With Head Item #9 & #10	
21	901009	Relief, Main Valve	
22	910065	Relief, Seal Kit	

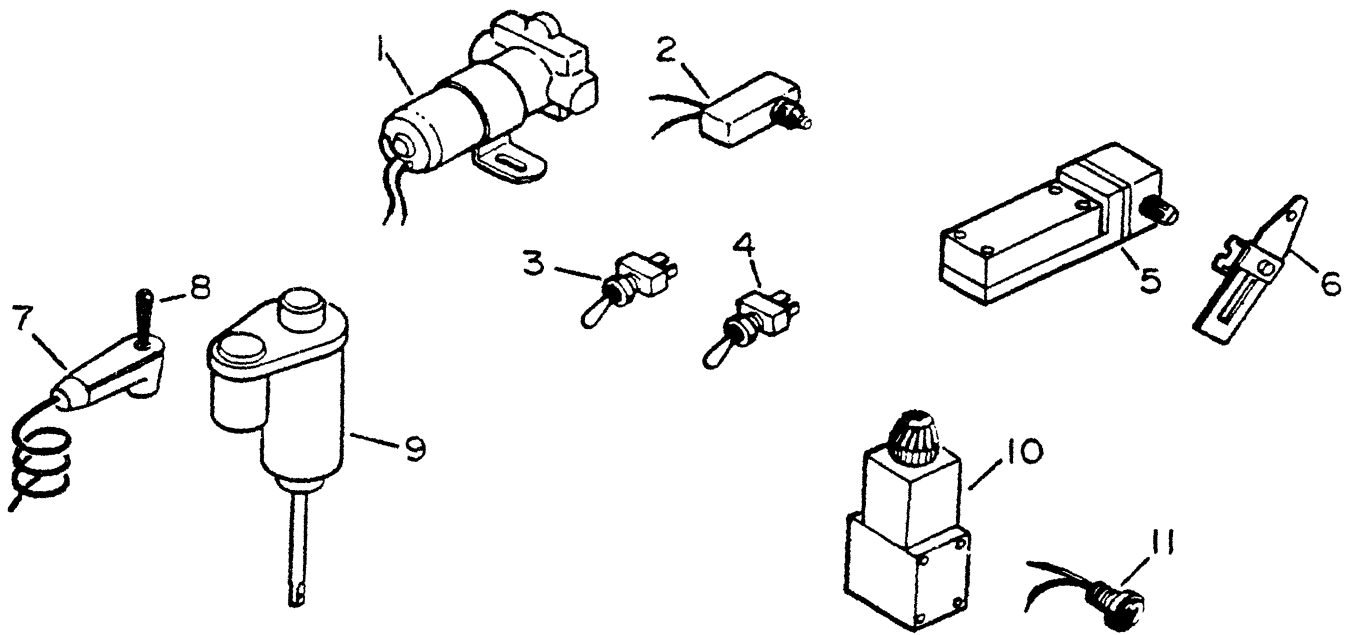

**SAFETY DECALS AND INFORMATIVE  
DECALS/8000 B & BH**



ITEM NO.	PART NUMBER	DESCRIPTION	QTY.
	940000-0	Decal kit, complete (8000 BH, 8000 B & 8000) Consists of small decals & big orange stripes decals	1
	940000-00	Decal Kit, consists of small decals; big orange decals NOT included	1
1	940001-1	Located in the upper RH corner of fuel tank	1
2	940001-2	Located just below fuel tank mount	1
3	940001-3	Located on the upper rear of side panels	2
4	940001-4	Located on the Hyd. tank, LH top	1
5	940001-5	Located under the feeder on the right side	1
6	940001-6	Located on the flat surface of guard plate	2
7	940001-7	Located on the front of drive lever controls	1
8	940001-8	Located on both sides of auger back top	2
9	940001-9	Located on the front lower edge of hopper	2
10	940001-10	Located on the shifter handle	1
11	940001-11	Located in front of the Conveyor lift valve	1
12	940001-12	Located on shifter bracket (Gearbox only)	1
13	940002-1	Located in front center of paver	1
14	940002-2	Located underneath feeders by the track adj.	2
15	940002-3	Located left of center on top of door	1
16	940002-4	Located on flat surface, just ahead of the flight screw	2
17	940002-5	Located on hopper sides 4" in and about 8" down from the top rear	2
18	940002-6	Located on the face of plate guard in front of the valve handle	1
19	940002-7	Located under the hopper on gearbox	1
20	940003-1	Located on the motor shield	1
21	940003-2	Located on both hopper sides, 1 1/2" up from the edge	2
22	940003-3	Located on the center of hose containment guards	2
23	940003-4	Located behind the "B" on decal no. 21	2
24	940004-1	Located on both cutoff ends	2
25	940004-2	Located on the instrument panel, so the arrows point to the correct component	
26	940004-3	Located on the drive controls with the "N" by the notch, showing position of neutral	1
27	940004-4	Located on the face plate, up from the valve	1
28	940004-5	Located on the face plate ahead of right hand drive controls	1
29	940004-6	Decal Automatic Burner Instructions (N/S)	
30	940004-8	Elite Decal (N/S)	

# SPROCKET DRIVE TRACK SYSTEM

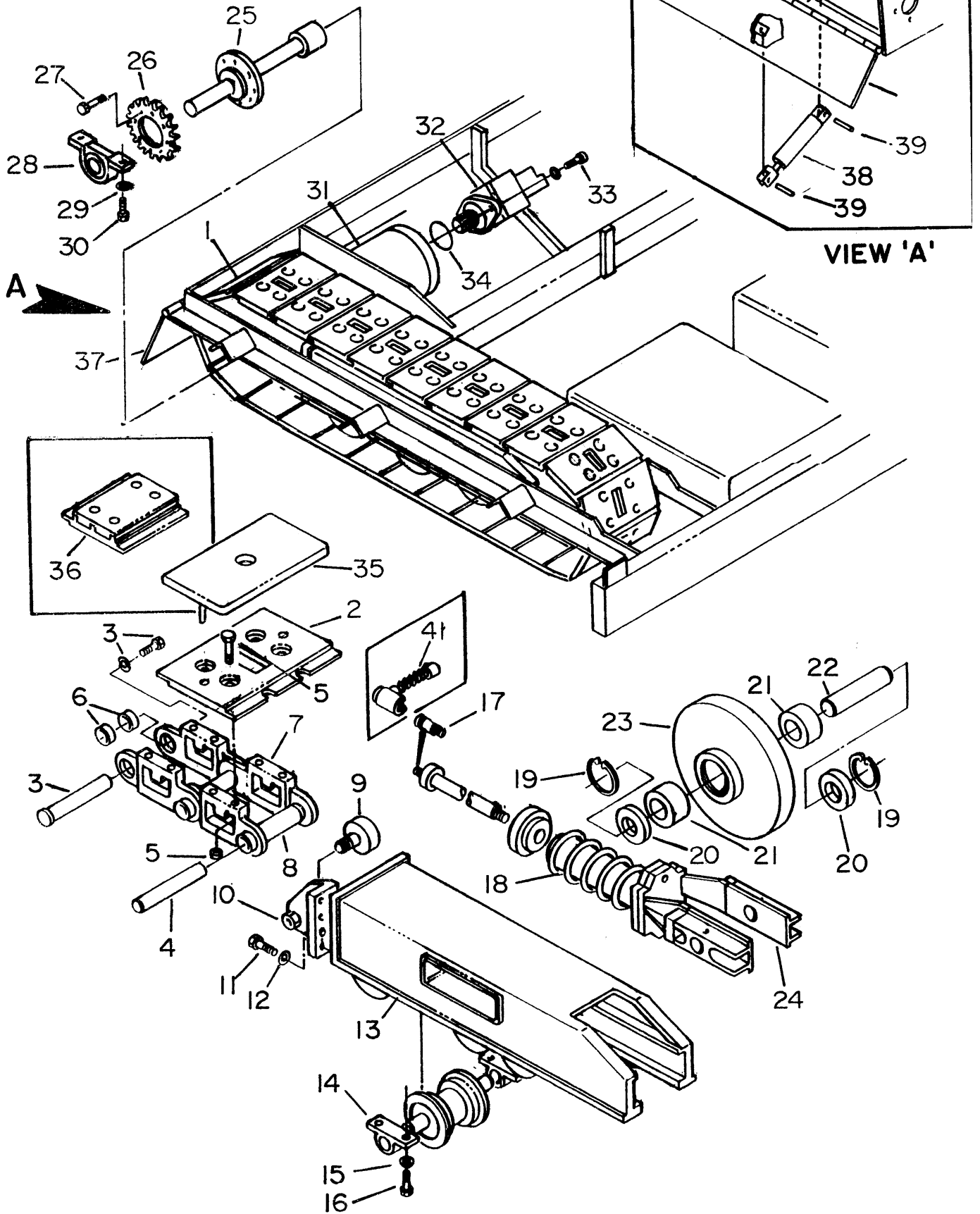

# SPROCKET DRIVE TRACK SYSTEM



ITEM NO.	PART NUMBER	DESCRIPTION	QTY.
1	811300	Track, Complete	2
	811302	Chains, B O Rail (Not Shown)	2
2	811304	Pads, Track	A/R
3	811306	Pins, Master (Complete)	A/R
4	811307	Pins, Plain	A/R
5	811308	Bolts, Pads	A/R
6	811310	Spacers	A/R
7	811312	Links	A/R
8	811314	Bushings	A/R
9	811316	Roller, Stabilizer	2
10	811318	Nut, Roller Stabilizer	2
11	811320	Bolts, Roller Stabilizer	6
12	811322	Lockwasher, Roller Stabilizer	6
13	811324	Side Frame, Complete (R/H Shown)	1
14	811326	Roller, Complete	8
15	811328	Lockwasher, Roller	A/R
16	811330	Bolts, Roller	A/R
17	811332	Nipple, Grease	2
18	811334	Cylinder, Grease	2
19	811336	Snap Ring, Idler	4
20	811338	Seal, Idler	4
21	811340	Bearing, Idler	4
22	811342	Axle, Idler	2
23	811344	Idler, Complete	2
24	811346	Yoke, Idler	2
25	811348	Axle, Main	2
26	811350	Sprocket, Drive	2
27	811352	Bolts, Sprocket	A/R
28	810140	Bearing, (2 1/4")	2
29	811356	Lockwashers	4
30	811358	Bolts	4
31	811360	Torque Hub	2
32	811362	Motor, Drive	2
33	811364	Bolts & Lockwashers	4
34	811366	Gasket	2
35	811368	Poly Pad, (Bolt On) (12")	A/R
35A	811369	Poly Pad, (Bolt On) (14")	A/R
36	811370	Poly Shoe, Complete	A/R
37	811372	Cutoff, Complete	1
38	811374	Cutoff, Cylinder	2
39	811376	Pins, Cylinder	4
40	811378	Seal Kit, Grease Cylinder (N/S)	2
41	811380	Track, Adjuster Tool	1
42	811302	Chain, Rails	

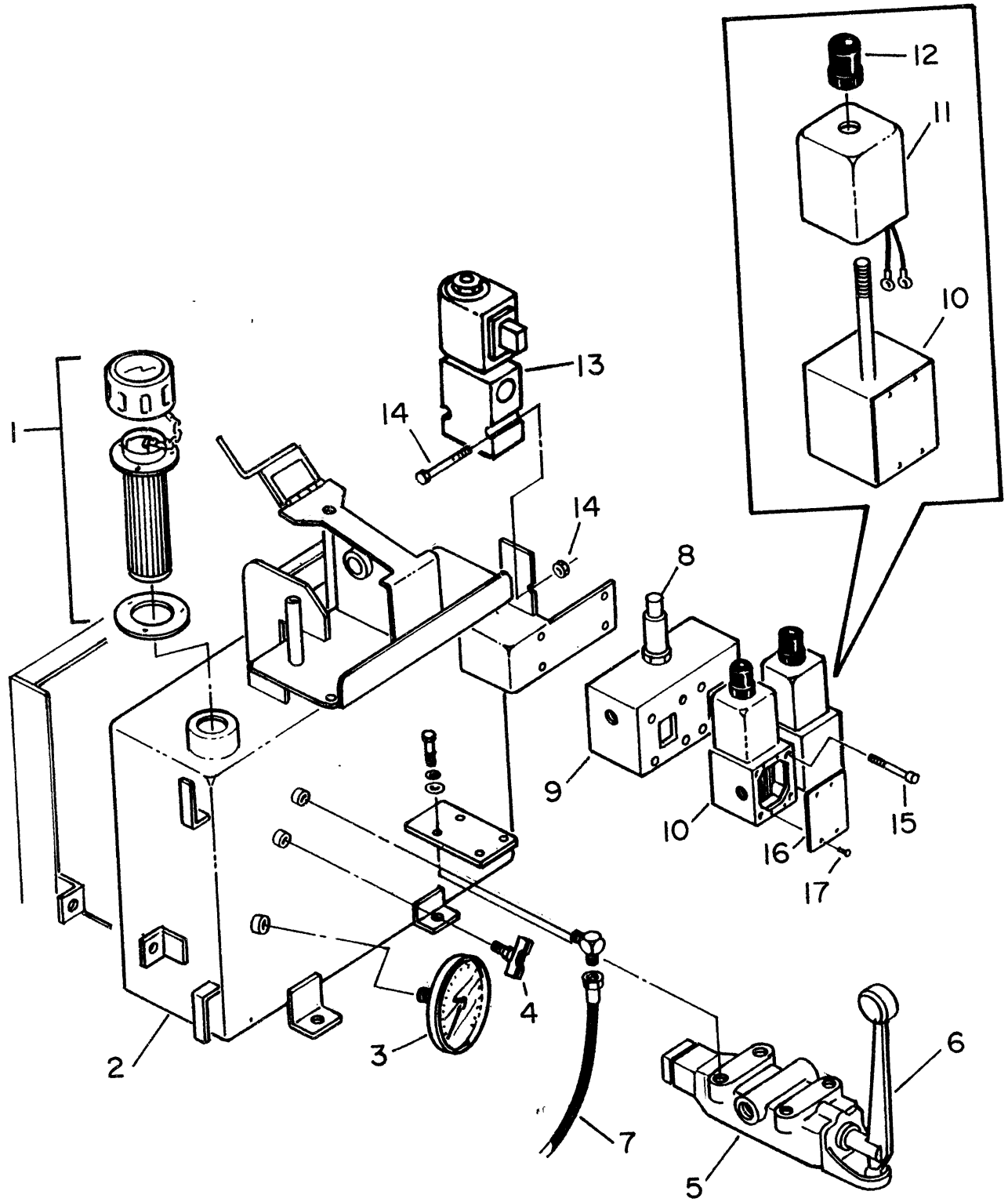

## HYD. COMPONENTS



ITEM NO.	PART NO.	DESCRIPTION	QTY.
1	910160	Cap, Breather Oil	1
2	840014	Tank, Hyd. (Top)	
3	330040	Gauge, Temp.	1
4	910150	Petcock	1
5	910120	Valve, Conveyor	1
6	910130	Lever, Conveyor	1
7	910135	Hose, Vent	1
8	900092	Relief, Conv.	1
9	900094	Manifold, Conv.	1
10	900100	Valve, Conv. Complete	2
11	900125	Coil	1
12	900097	Nut	1
13	900140	Valve, 2 Speed	1
14	900098	Bolt & Nut	2
15	900099	Bolts, Valve	4
16	900143	Plate, Valve	1
17	900145	Screws, Plate	4
18	910122	Valve Block, Sidewings (N/S)	

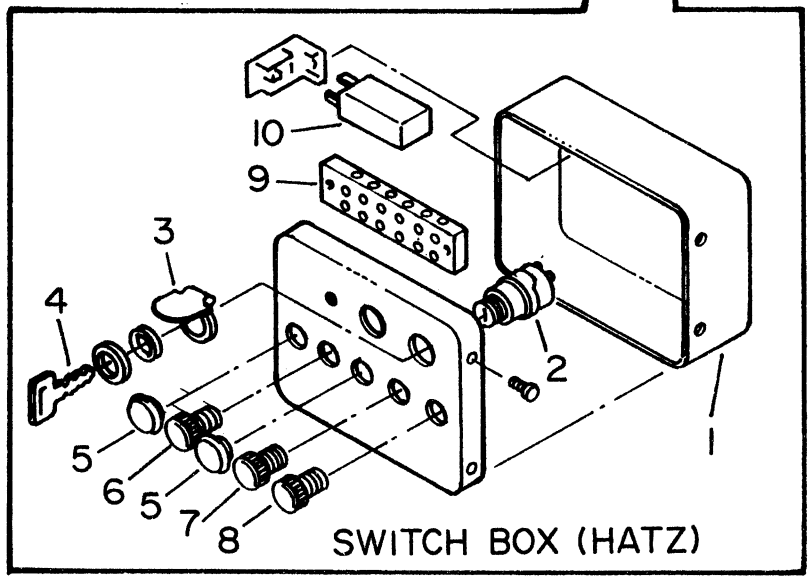
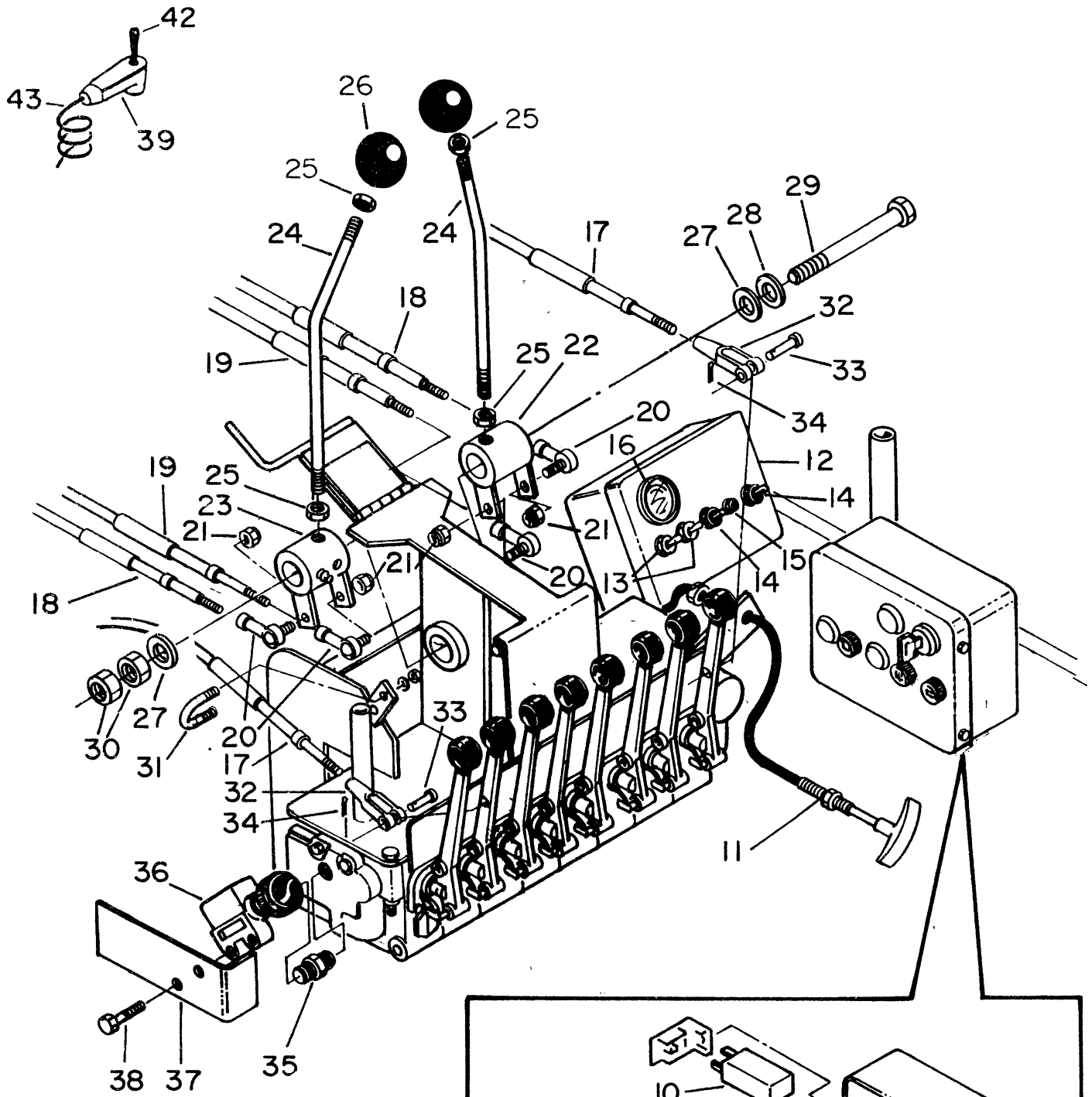

**SPECIAL COMPONENTS L/H SIDE (REAR)**



ITEM NO.	PART NO.	DESCRIPTION	QTY.
1	320425	Switchbox, Complete Hatz	1
2	320390	Switch, Hatz	
3	320370	Cover Only, Switch	1
4	320380	Keys, Hatz	1
5	320382	Plugs	
6	320384	Light, Indicator	
7	320385	Light, Indicator	
8	320386	Light, Indicator	
9	320340	Block	
10	320320	Relay	1
11	920160	Cable, Throttle Hatz	1
12	920165	Dash, Complete	
13	900030	Switch, Toggle, Conv.	2
14	500040	Switch, Toggle, 2 Speed & Spraydown	2
15	900120	Light, Conv.	1
16	900130	Meter, Hour	1
17	920140	Cable, Auger (116 x 3)	1
18	920140	Cable, Drive R/H (116 x 3)	2
19	920120	Cable, Pump (104 x 3)	2
20	920090	Rodend, Spherical, with Stud	4
21	920092	Nut, 3/8 Fine Thread	4
22	920094	Pivot, R/H	1
23	920096	Pivot, L/H	1
24	920097	Handle, Drive	2
25	920098	Nuts, Jam	4
26	920225	Knob	
27	920226	Washer, Flat 5/8"	2
28	920227	Washer, Bevel	2
29	920229	Bolt 5/8" x 7 1/2"	1
30	920231	Nuts, Jam	2
31	900713	U-Bolts, 3/8	6
32	350050	Clevis, Yoke	2
33	850099	Pin, Clevis	2
34	850100	Pin, Cotter	2
35	920233	Coupler	1
36	910080	Valve, Vibrator	1
37	920234	Shield	
38	920237	Bolts	
39	920238	Control, Remote (Electric Flight Screw)	1
40	900020	Switch, Safety (Mounted at controls) (N/S)	1
41	900029	Bracket, (Safety Switch) (At Controls)	1
42	900080	Switch, Remote (Only)	1
43	900082	Cord, Remote	1

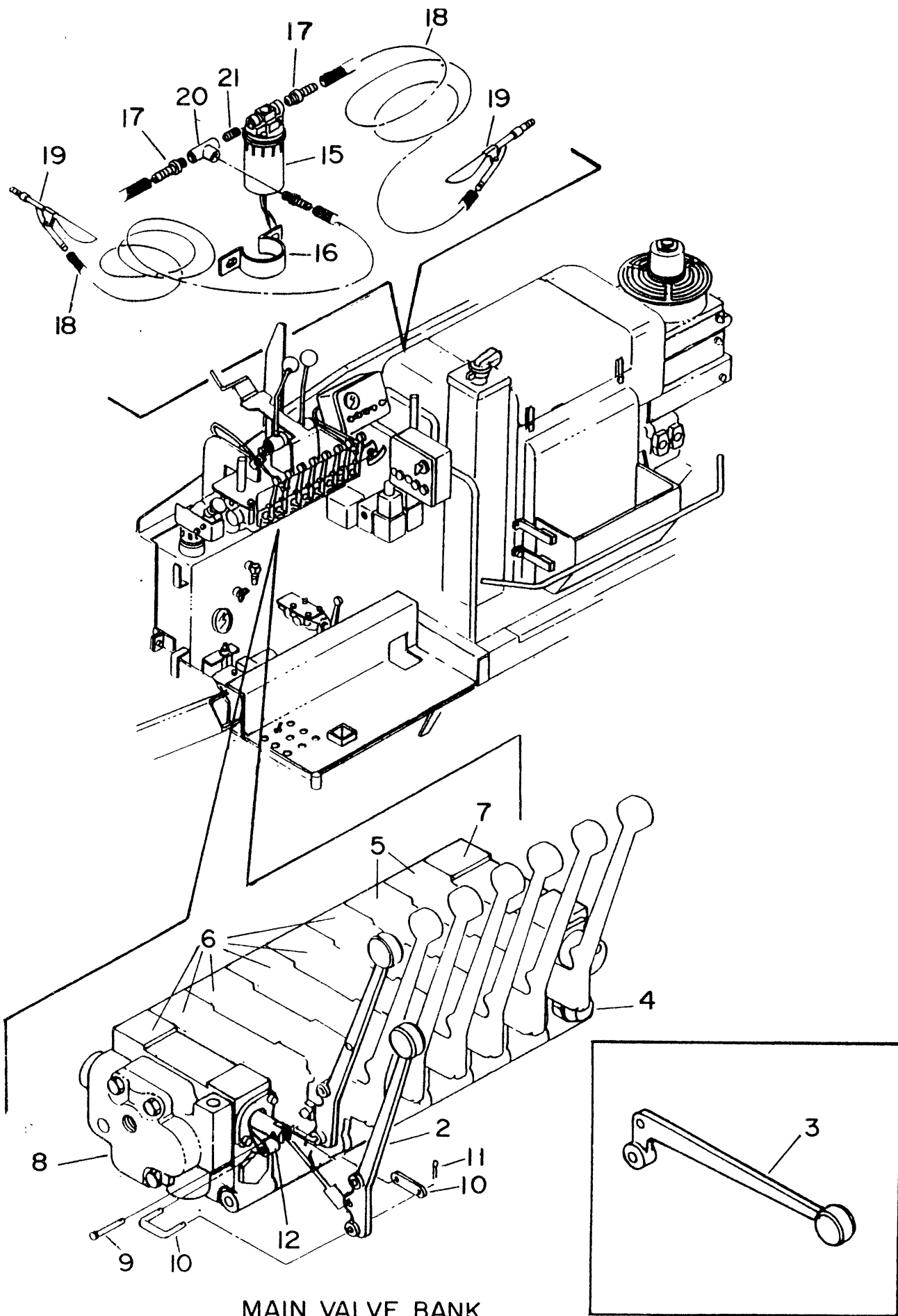

MAIN VALVE BANK  
 ITEM No. 1

# MAIN VALVE



ITEM NO.	PART NO.	DESCRIPTION	QTY.
1	910050	Valve, Main	
2	910060	Handle, Vertical	
3	910070	Handle, Horizontal	
4	901009	Valve, Relief (Main)	
5	910052	Section, Valve (Augers) (Detented)	
6	910054	Section, Valve (Cylinders) (Spring Return)	
7	910055	Cover, Inlet	
8	910056	Cover, Power Beyond	
9	850099	Pin, Clevis (1/4")	
10	901010	Link, Handle	
11	850100	Pin, Cotter (1/4")	
12	910058	Bracket, Handle (Aluminum)	
13	901007	Detent Kit (N/S)	
14			
15	900010	Pump, Spraydown (Flojet)	
16	900012	Bracket, Pump (Spraydown)	
17	920218	Coupling, Hose	
18	920219	Hose, (15' 5/16")	
19	920220	Handle, Spraydown	
20	920222	Tee, 3/8"	
21	920223	Nipple, 3/8"	
22	901210A	Tips, Spray Handle (N/S)	
		<b><u>SEAL KITS FOR VALVES</u></b>	
	910059	Kit, Seal (Spool) (Gresen V-20) K6125B	
	910062	Kit, Seal (Section) (Gresen V-20) K6121	
	910065	Kit, Seal (Relief Valve) (Gresen V-20)	

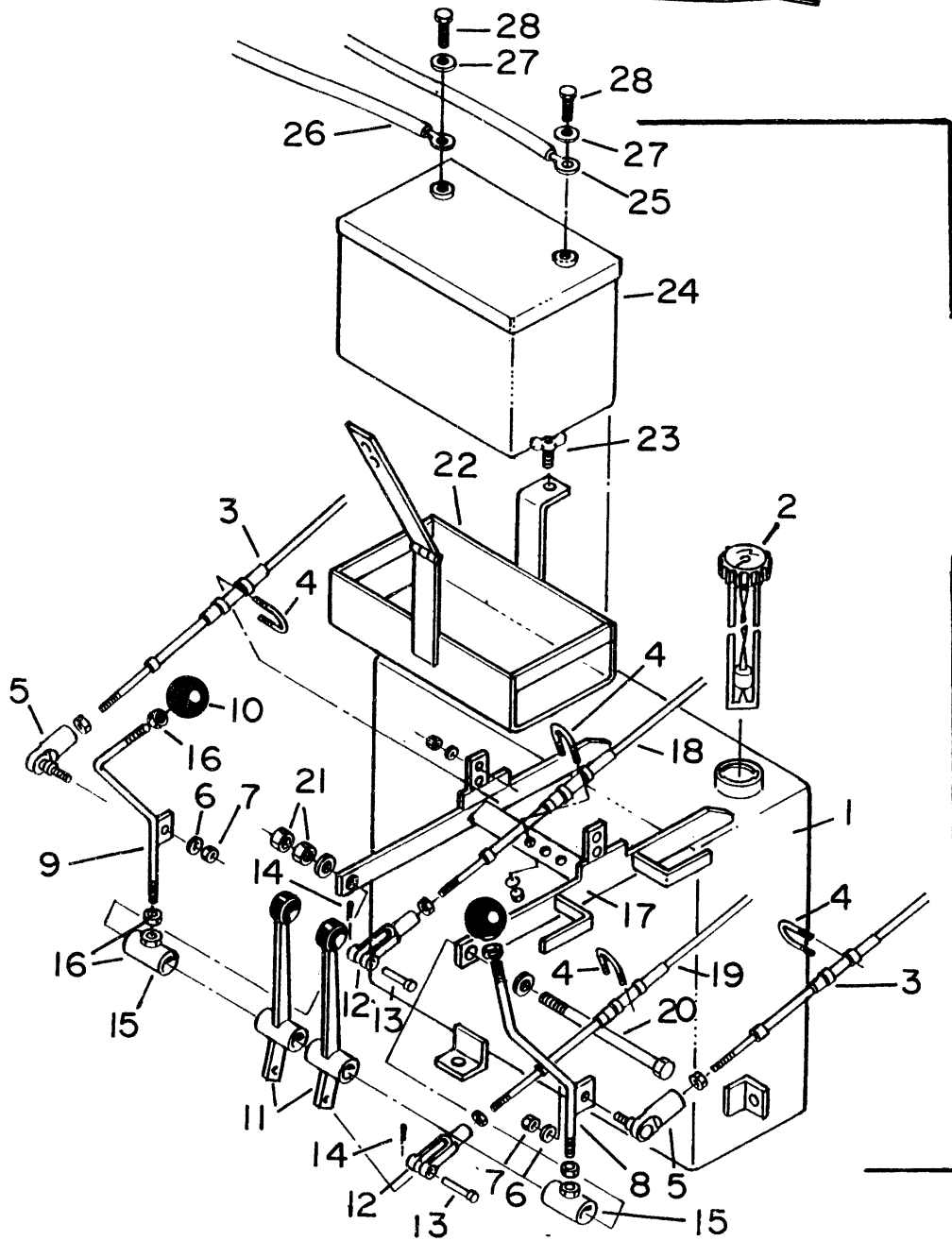
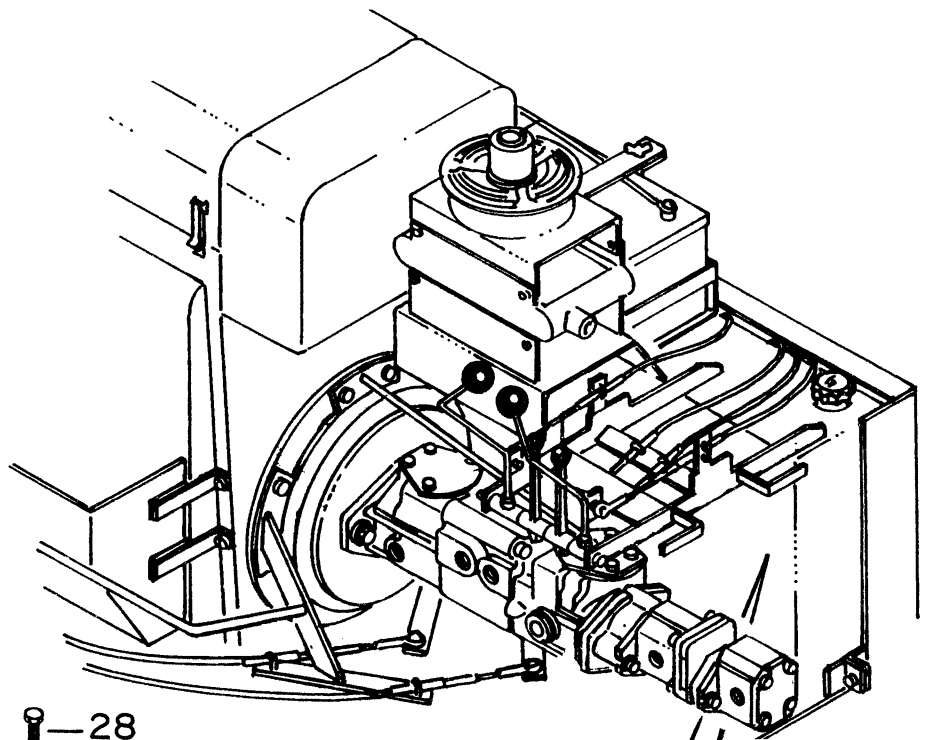

## R/H DRIVE ASSEMBLY



ITEM NO.	PART NO.	DESCRIPTION	QTY.
1	910009	Fuel Tank, (Complete	
2	910010	Gauge, Fuel	
3	920140	Cable, R/H Drive (116" x 3") (Older Units With Quadco Take 116" x 5" Cable Part # 920110)	
4	900713	U-Bolts, 3/8"	
5	920090	Rodend, Spherical With Stud, 3/8" Fine Thread	
6	920072	Lockwasher, 3/8"	
7	920093	Nut, 3/8"	
8	920230	Handle, (R/H) (Lee-Boy)	
9	920228	Handle, (L/H) (Lee-Boy)	
10	920225	Knobs, Round	
11	920210	Handles, (Right Extension) (Right Auger) (Casted)	
12	350050	Clevis, Yoke 1/4"	
13	850099	Pins, (1/4")	
14	910057	Pin, Cotter	
15	350054	Pivot, Handle	
16	350055	Nuts, 1/2"	
17	350059	Bracket, R/H Drive	
18	920140	Cable, R/H Auger (116" x 3")	
19	920130	Cable, R/H Extension (123" x 3")	
20	920145	Rod, For R/H Drive Handle (5/8")	
21	920147	Nuts, Jam (5/8")	
22	920151	Box, Battery	
23	920070	Bolt, (3/8") Wing	
24	920155	Battery	
25	900147	Cable, (-) (Battery)	
26	900148	Cable, (+) (Battery)	

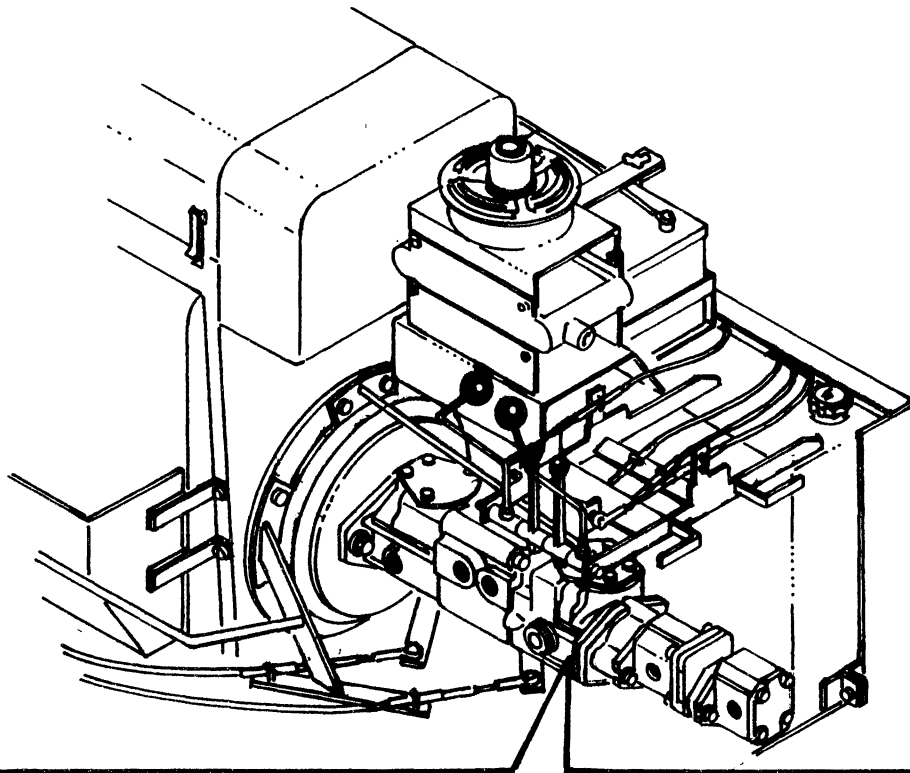

PUMP COMPONENTS

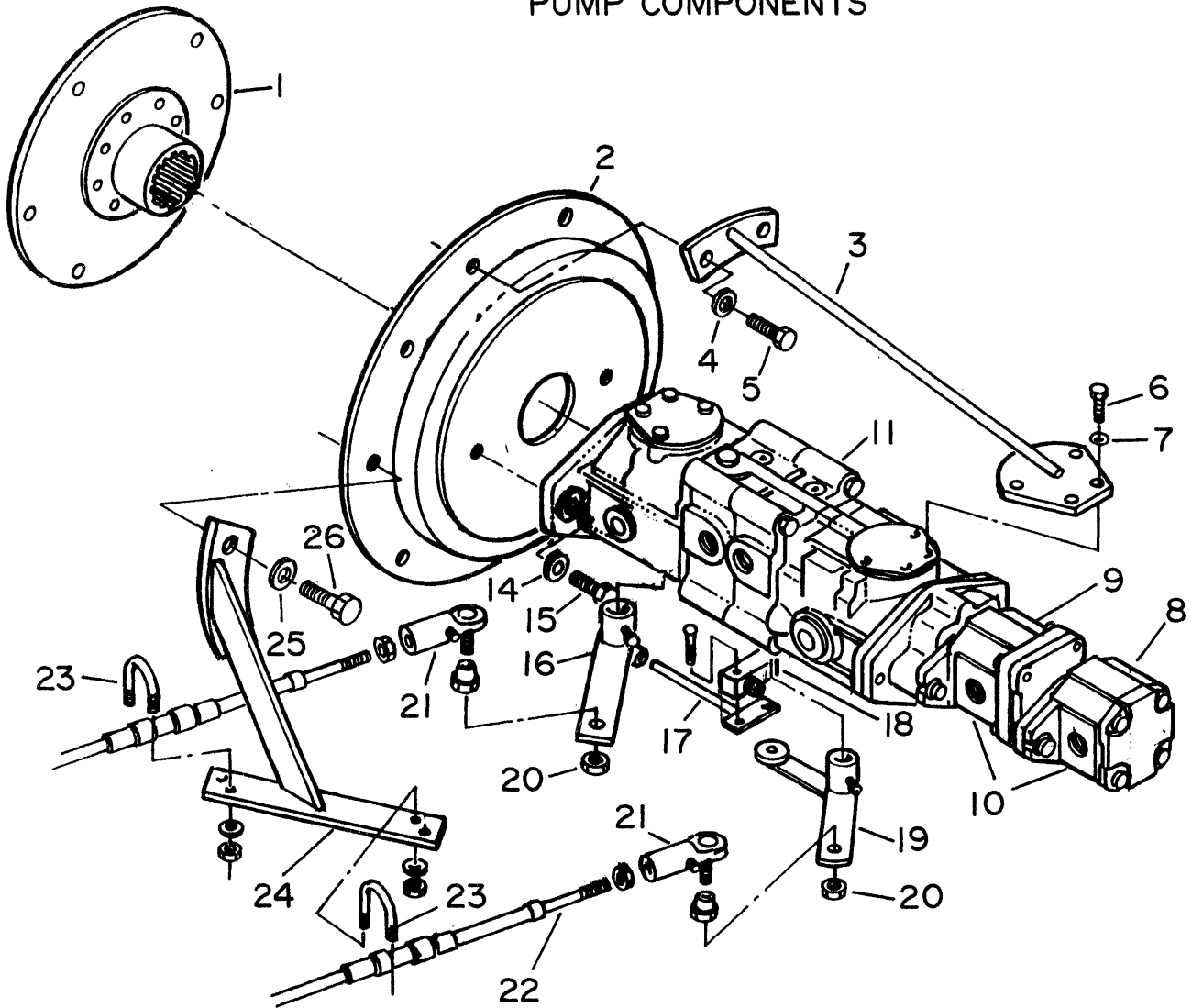

# PUMP COMPONENTS



ITEM NO.	PART NO.	DESCRIPTION	QTY.
1	320170	Coupling, Inner Drive	1
2	320200	Cover, Pump Plate	1
3	320224	Brace, Pump (Sunstrand)	1
4	320226	Washer, Lock	2
5	320227	Bolt	2
6	320228	Bolt	8
7	320229	Washer, Lock	8
8	320420	Pump, Double Gear (Conv. & Augers)	1
9	320234	Kit, Rebuild (Main Pump) (N/S)	1
10	320235	O-Ring, (Piggyback to Main Pump) (N/S)	1
11	320237	Pump, L & R Drive (Sunstrand)	1
12	320239	Seal, Front (Sunstrand) (N/S)	1
13	320241	O-Ring, Front (Sunstrand) (N/S)	1
14	320242	Washer	2
15	320243	Bolt	2
16	320245	Arm, Left Drive	1
17	320246	Arm, Safety Switch	1
18	900022	Switch, Safety (Neutral) (New Style)	1
	900020	Switch, Safety (Neutral) (Old Style)	1
19	900025	Arm, Right Drive	1
20	900027	Nut	2
21	920090	Rodend, Spherical With Stud	2
22	920120	Cable, Pump (104" x 3")	2
23	900713	U-Bolt, (3/8")	2
24	920125	Bracket, Pump Cables	1
25	320226	Washer, Lock	2
26	320227	Bolt	2

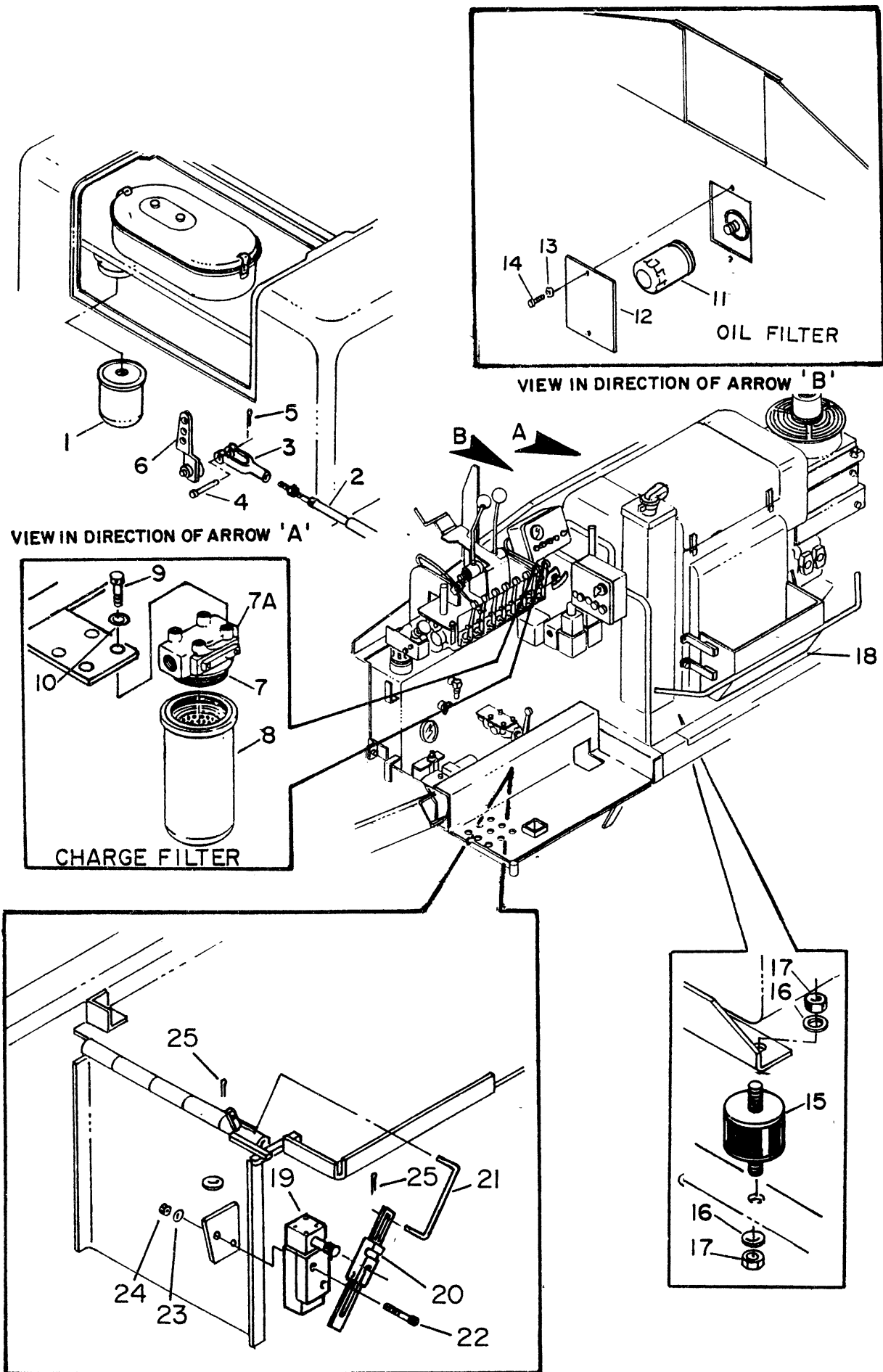

**FILTER LOCATION & ACCESSORIES  
(HATZ)**



ITEM NO.	PART NO.	DESCRIPTION	QTY.
1	310080	Filter, Fuel (Hatz)	1
2	920160	Cable, Throttle (36" x 3") (T-Handle)	1
3	350050	Clevis, Yoke (1/4")	1
4	850099	Pin, Clevis (1/4")	1
5	910057	Pin, Cotter (1/16")	1
6	350056	Arm, Adjustment	1
7	290010	Filter, Head (For Charge Filter) (Must buy complete assembly When ordering this part use part # 290025)	1
7A	290012	Gauge, Head	1
8	290030	Filter, Hydraulic (Charge)	1
9	290032	Bolt 3/8" x 1"	4
10	290034	Washer 3/8"	4
11	310070	Filter, Oil	1
12	310075	Cover, Access Oil Filter	1
13	290032	Bolt 3/8" x 1"	2
14	290034	Washer, Lock 3/8"	2
15	320140	Mount, Engine (Hatz)	4
16	320142	Washer, Lock (metric)	4
17	320144	Nut (metric)	4
18	320112	Shield, Heat	1
19	900050	Switch, Micro	1
20	900060	Arm, Micro	1
21	900075	Linkage	1
22	900076	Screws	
23	900077	Lock Washer	
24	900078	Nut	
25	900079	Pin, Cotter	
26	290025	Assembly Complete Hydraulic Filter With Head Item #7 & #8	

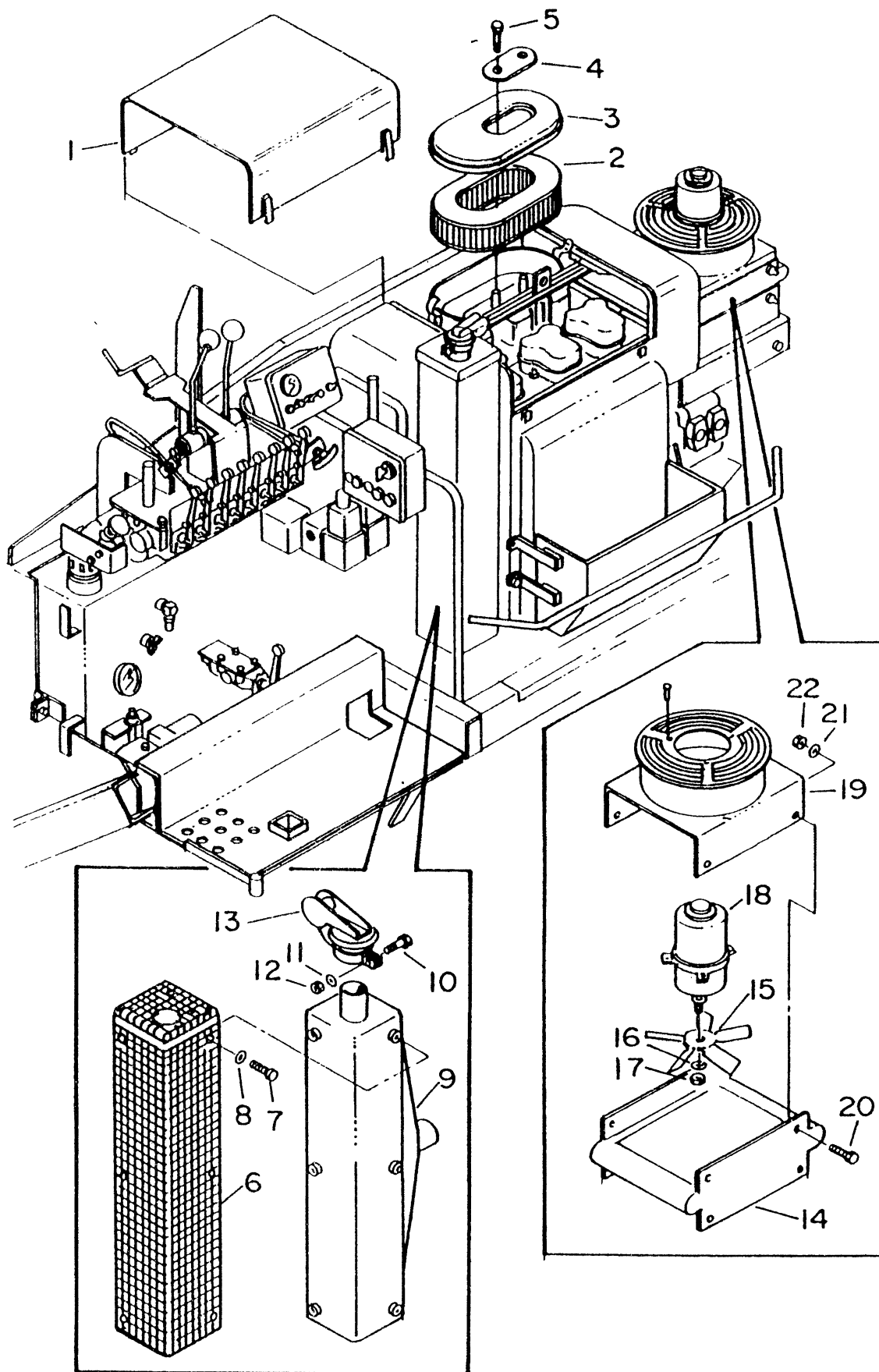

**ENGINE COMPONENTS  
(HATZ)**



<b>ITEM NO.</b>	<b>PART NO.</b>	<b>DESCRIPTION</b>	<b>QTY.</b>
1	320500	Cover, Engine Access	1
2	310060	Filter, Air Cleaner	1
3	320504	Cover, Air Cleaner	1
4	320506	Bracket, Hold Down Filter	1
5	320508	Bolt	2
6	320510	Shield, Muffler	1
7	320512	Screw	3
8	320514	Washer, Lock	3
9	320516	Muffler	1
10	320518	Screw	1
11	320520	Washer, Lock	1
12	320522	Nut	1
13	320524	Cap, Exhaust	1
14	320526	Cooler, Oil (When ordering this part use part #320529)	1
15	320528	Fan	1
16	320530	Washer, Lock	1
17	320532	Nut, Hex	1
18	320534	Motor, Electric Fan	1
19	320536	Shroud, Fan (When ordering this part use part #320529)	1
20	320538	Bolt	4
21	320540	Washer, Lock	4
22	320542	Nut, Hex	4
23	320529	Oil Cooler Assembly Complete With Fan & Motor	

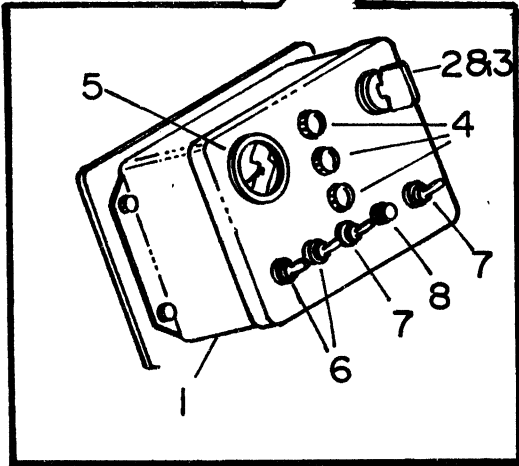
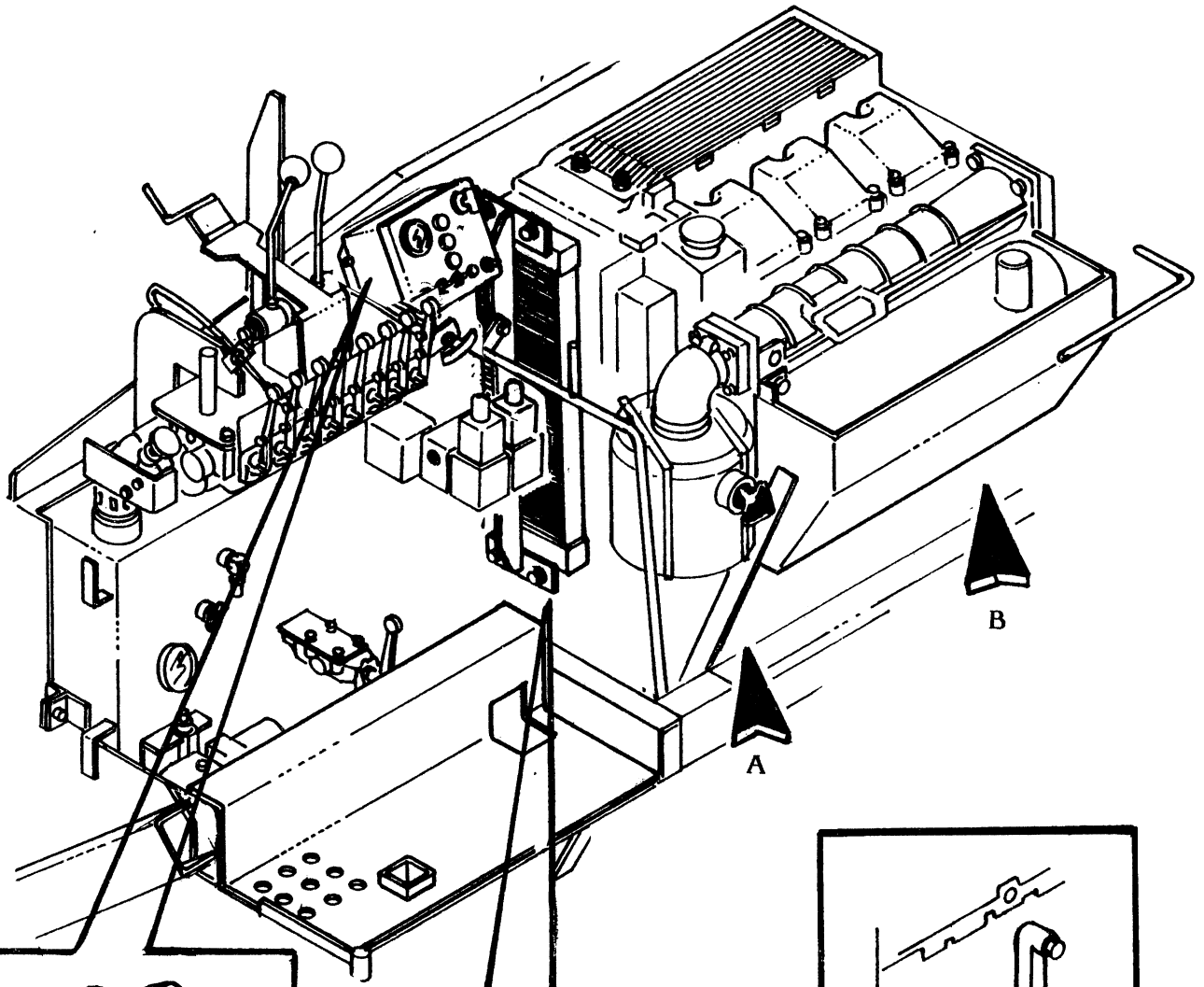

DEUTZ SWITCHBOX

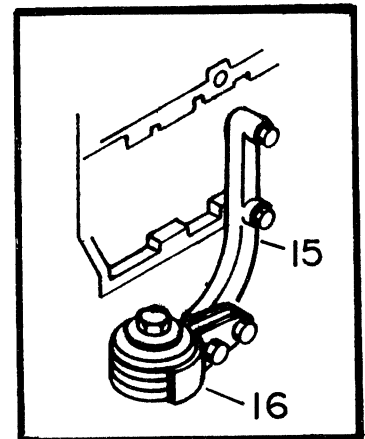
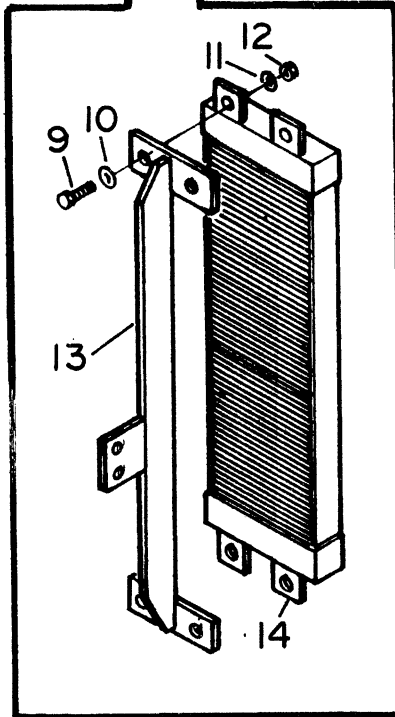

VIEW AND DIRECTION OF ARROW A

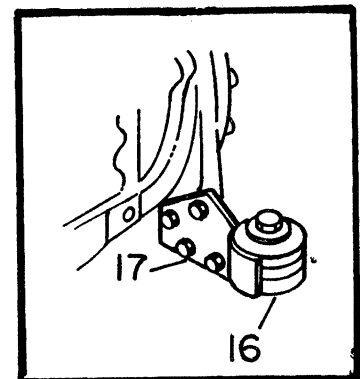

VIEW AND DIRECTION OF ARROW B

**DEUTZ COMPONENTS**

<b>ITEM NO.</b>	<b>PART NO.</b>	<b>DESCRIPTION</b>	<b>QTY.</b>
1	900154	Dash, Complete	1
2	900156	Switch, Deutz	1
3	900158	Key, Deutz	1
4	900160	Light, Idiot	1
5	900130	Meter, Hour	1
6	900030	Switch Conveyor	1
7	500040	Switch, 2-Speed & Spraydown	1
8	900120	Light, 2-Speed	
9	900145	Bolt	
10	900155	Washer, Flat	
11	900157	Washer, Lock	
12	900159	Nut, Hex	
13	900161	Mount, Oil Cooler	
14	910110	Cooler, Oil	
15	900164	Arm, Motor Mount	
16	900166	Mount, Rubber (Deutz)	
17	900168	Plate, Mount	

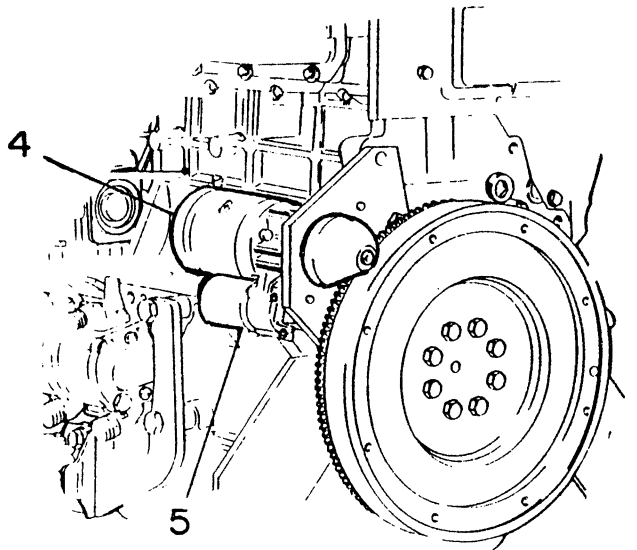
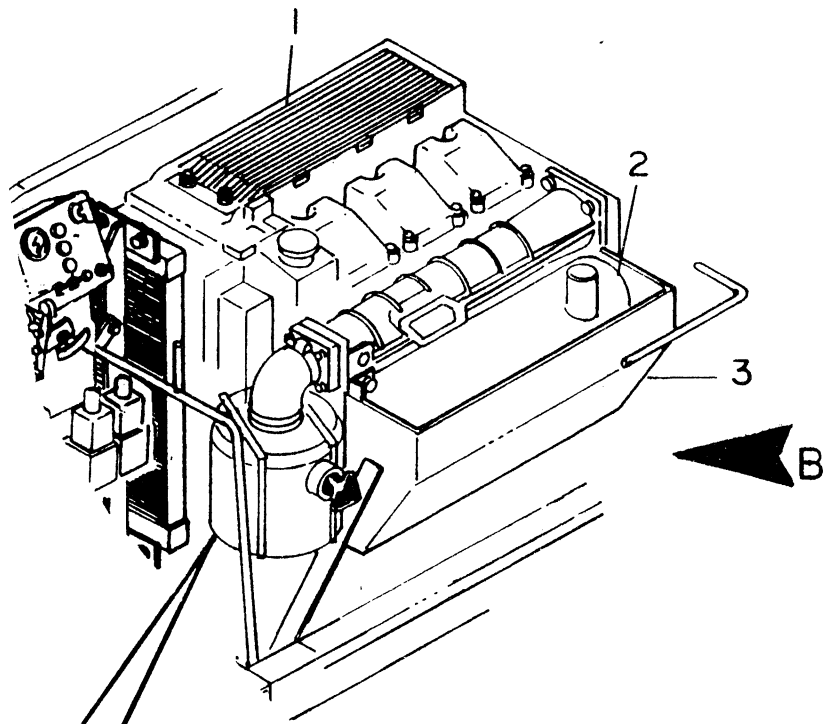

VIEW IN DIRECTION OF ARROW 'B'

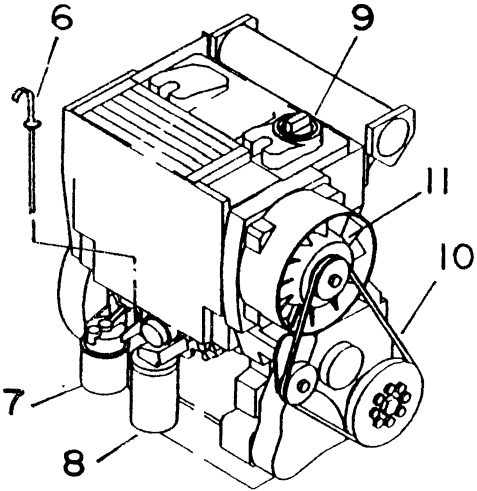

VIEW IN DIRECTION OF ARROW 'A'

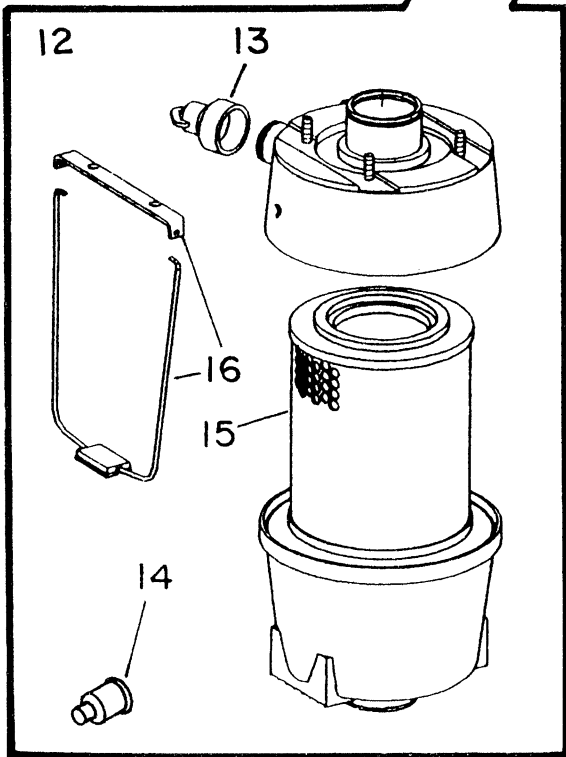

**DEUTZ ENGINE COMPONENTS**

<b>ITEM NO.</b>	<b>PART NO.</b>	<b>DESCRIPTION</b>	<b>QTY.</b>
1	950026	Cooler, Engine Oil	1
2	950025	Muffler, Engine	1
3	950027	Shield, Muffler	1
4	950004	Starter, Engine	1
5	950005	Solenoid	1
6	950006	Stick, Dip	1
7	950010	Filter, Fuel	1
8	950020	Filter, Oil	1
9	950007	Cap, Oil Fill	1
10	950008	Belt	1
11	950009	Alternator	1
12	950012	Assembly, Air Cleaner	1
13	950014	Cap,(Rubber)	1
14	950016	Gauge, Pop-Off	1
15	950000	Filter, Element	1
16	950018	Bracket, Hold-Down	2
17	950021	Horn, Air Breather	1
<b>*NOTE: ANY OTHER ENGINE COMPONENTS CALL IN PART NUMBER OUT OF ENGINE PARTS BOOK THAT CAME WITH MACHINE.*</b>			

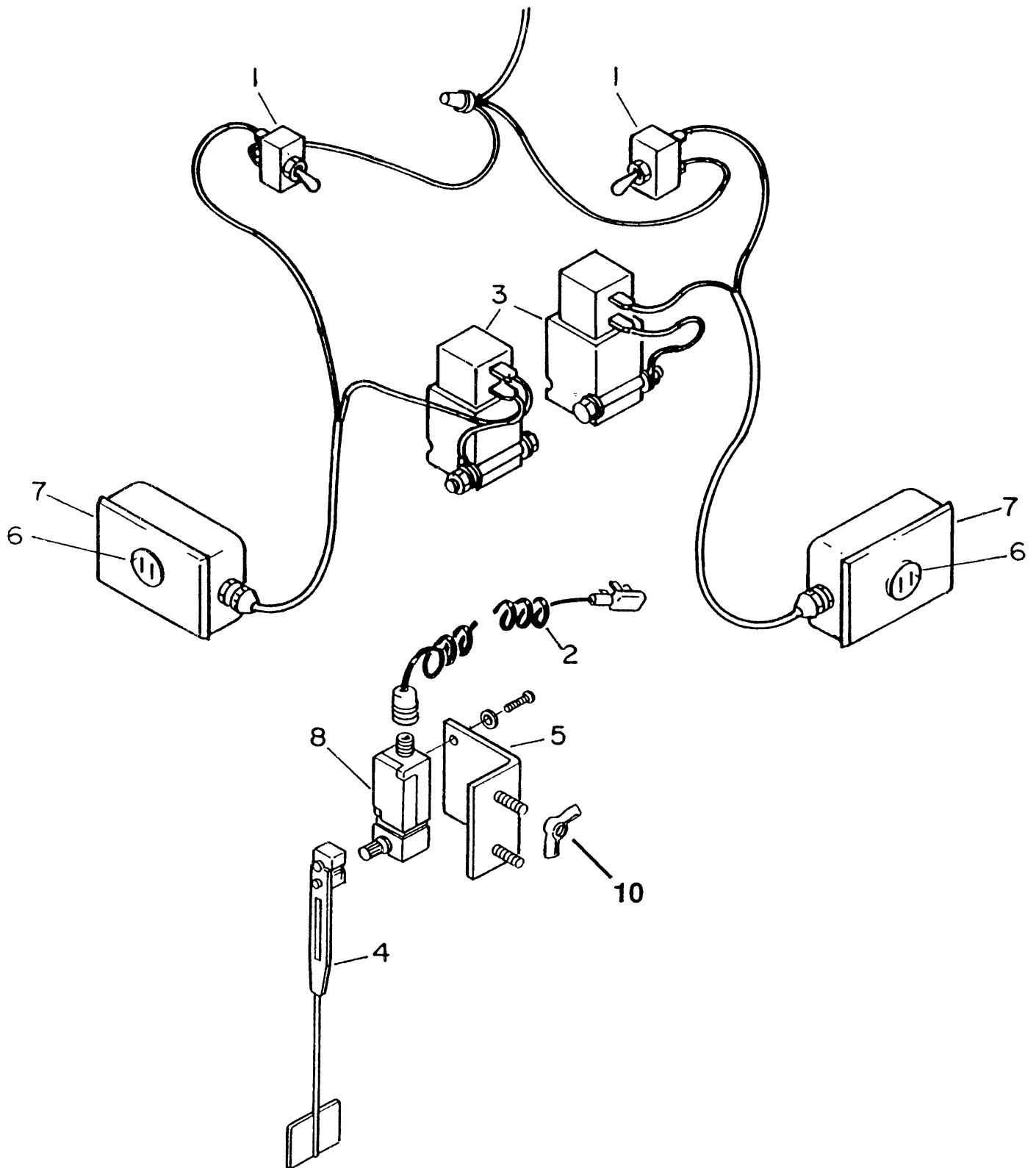

**AUTOMATIC AUGER ELECTRICAL  
COMPONENTS**



ITEM NO.	PART NO.	DESCRIPTION	QTY.
1	500040	Switch, toggle	2
2	900142	Cord, stretch	2
3	900132	Valve	2
4	900146	Paddle	2
5	900150	Bracket, Switch	2
6	900151	Receptacle	2
7	900153	Cover, outlet	2
8	900135	Switch, automatic auger	2
9	940520	Manifold, Auto Augers (Both valves in one block) (N/S)	1
10	940522	Nut, Wing	

# UMBRELLA

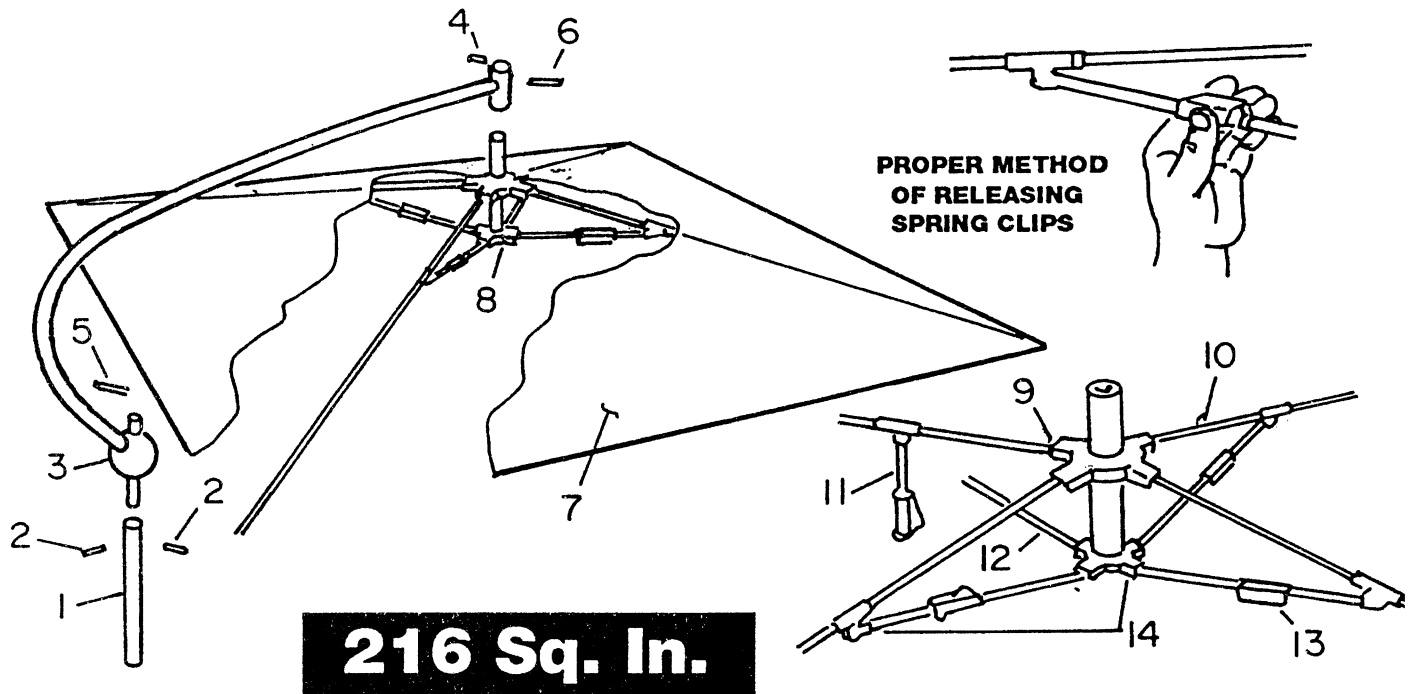

PROPER METHOD  
OF RELEASING  
SPRING CLIPS

**216 Sq. In.**

## ASSEMBLY INSTRUCTIONS

1. Install Umbrella Mounting bracket (See bracket mounting instructions furnished with each bracket).
2. Insert ball stud on (#3) curved shaft into (#1) umbrella support shaft, align holes, and drive (#2) 3/16" x 1" spiral spring pins into position. Install (#5) locking handle.
3. Place (#7) canvas cover over (#8) umbrella frame assembly and hook corners to bows — tie each bow securely with tie straps.
4. Insert (#8) umbrella frame assembly with canvas in place into tube on (#3) curved shaft and insert (#6) bolt. Tighten snugly with nut (#4).
5. Install complete umbrella into clamp on umbrella mounting bracket.

Each bow may be raised individually until locked into open position. Each bow has two positions in which it can be locked open. This is to allow for arc stretch in canvas.

\* Part No. varies with color.

**UMBRELLA**



<b>ITEM NO.</b>	<b>PART NO.</b>	<b>DESCRIPTION</b>	<b>QTY.</b>
	920235	Umbrella	1