

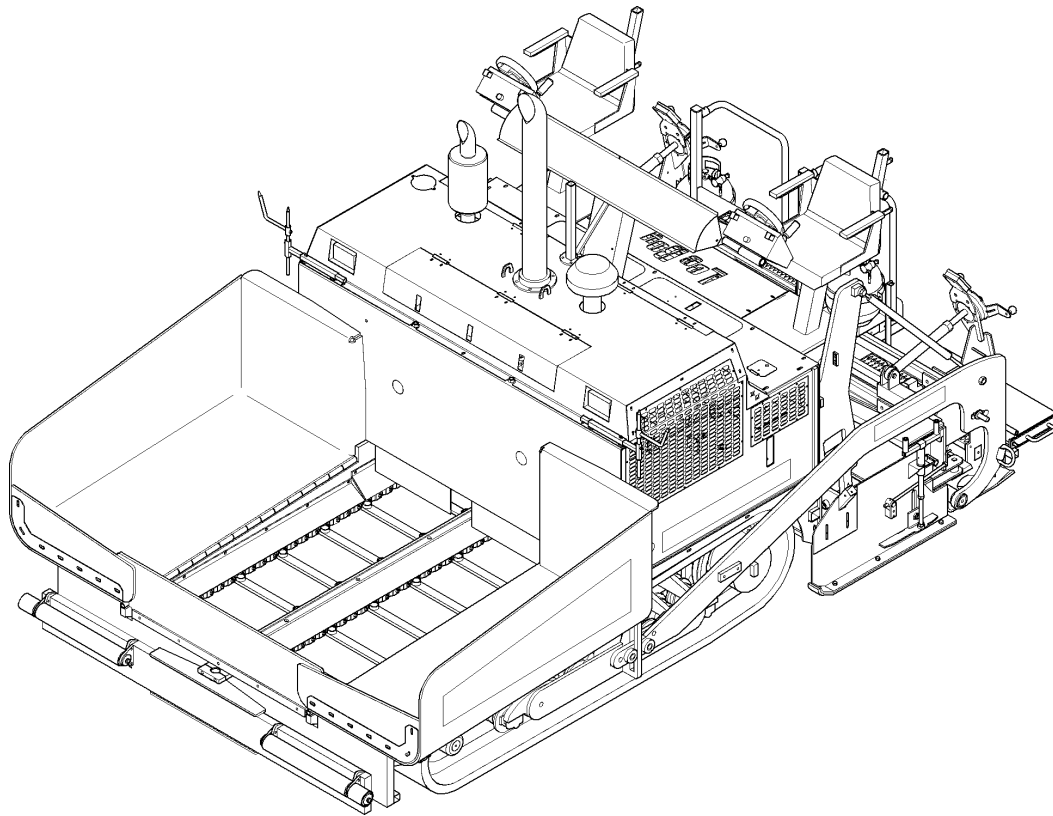

OPERATIONS, SERVICE AND PARTS MANUAL



8816 CONVEYOR PAVER

Manual No. 981620

LIMITED WARRANTY POLICY AND PROCEDURES

EFFECTIVE FOR UNITS SHIPPED AFTER DECEMBER 1, 2001

WARRANTY

1. If a defect in material or workmanship is found and the authorized dealer is notified during the warranty period, LeeBoy will repair or replace any part or component of the unit or part that fails to conform to the warranty during the warranty period.
2. The warranty date will begin upon the completion of the warranty form by the initial customer and will expire after twelve (12) months have passed. The Warranty Card should be filled out within (10) days of delivery of the unit.
3. Engines are warranted by their manufacturers and may have warranty coverage that differs from that of LeeBoy.
4. Replacement parts furnished by LeeBoy are covered for the remainder of the warranty period applicable to the unit or component in which such parts are installed.
5. LeeBoy has the right to repair any component or part before replacing it with a new part.
6. All new replacement parts purchased by a LeeBoy dealer will carry a six (6) month warranty. Remanufactured parts purchased by a LeeBoy dealer will carry a ninety (90) day warranty.

ITEMS NOT COVERED

LeeBoy is not responsible for the following:

1. Charges for travel time, mileage, or overtime.
2. Charges related to transporting the product to and from the place at which warranty work is performed.
3. Airfreight charges related to transporting repair parts to the place at which warranty work is performed.
4. All used units or used parts of any kind.
5. Repairs due to normal wear and tear, or brought about by abuse or lack of maintenance of the equipment, except for premature failures, conveyor chains, polytrack pads, and track rails.

6. Attachments not manufactured or installed by LeeBoy.
7. Liability for incidental or consequential damages of any type including, but not limited to lost profits or expenses of acquiring replacement equipment.
8. Miscellaneous charges.

LIMITATIONS

LeeBoy has no obligation under this warranty for:

1. Any defects caused by misuse, misapplication, negligence, accident or failure to maintain or use in accordance with the most current operating instructions.
2. Unauthorized alterations.
3. Defects or failures caused by any replacement parts or attachments not manufactured by or approved by LeeBoy.
4. Failure to conduct normal maintenance and operating service, including without limitation, providing lubricants, coolant, fuel, tune-ups, inspections or adjustments.
5. Unreasonable delay, as established by LeeBoy, in making the applicable units or parts available upon notification of a service notice ordered by LeeBoy.
6. The warranty responsibility on all engines rests with the respective manufacturer.
7. LeeBoy may have support agreements with some engine manufacturers for warranty and parts support.

OTHER WARRANTIES

THE FOREGOING WARRANTY IS EXCLUSIVE AND IN LIEU OF ALL OTHER EXPRESSED STATUTORY AND IMPLIED WARRANTIES APPLICABLE TO UNITS ENGINES, OR PARTS WITHOUT LIMITATION, ALL IMPLIED WARRANTIES OF MERCHANTABILITY OR FITNESS FOR ANY PARTICULAR USE OR PURPOSE. IN NO EVENT, WHETHER AS A RESULT OF BREACH OF CONTRACT OR WARRANTY, OR ALLEGED NEGLIGENCE OR LIABILITY WITHOUT FAULT, SHALL LEEBOY BE LIABLE FOR SPECIAL, INCIDENTAL OR CONSEQUENTIAL DAMAGES, INCLUDING WITHOUT LIMITATION, LOSS OF PROFIT OR REVENUE, COST OF CAPITAL, COST OF SUBSTITUTED EQUIPMENT, FACILITIES OR SERVICES DOWNTIME COSTS, LABOR COSTS OR CLAIMS OF CUSTOMERS, PURCHASERS OR LESSEES FOR SUCH DAMAGES.

USER'S REFERENCE GUIDE

DELIVERY DATE _____

UNIT SERIAL NUMBER _____

ENGINE TYPE _____

ENGINE NUMBER _____

DEALER'S NAME AND ADDRESS

PHONE NUMBER _____

EQUIPMENT HOURS _____

SERVICE MANAGER _____

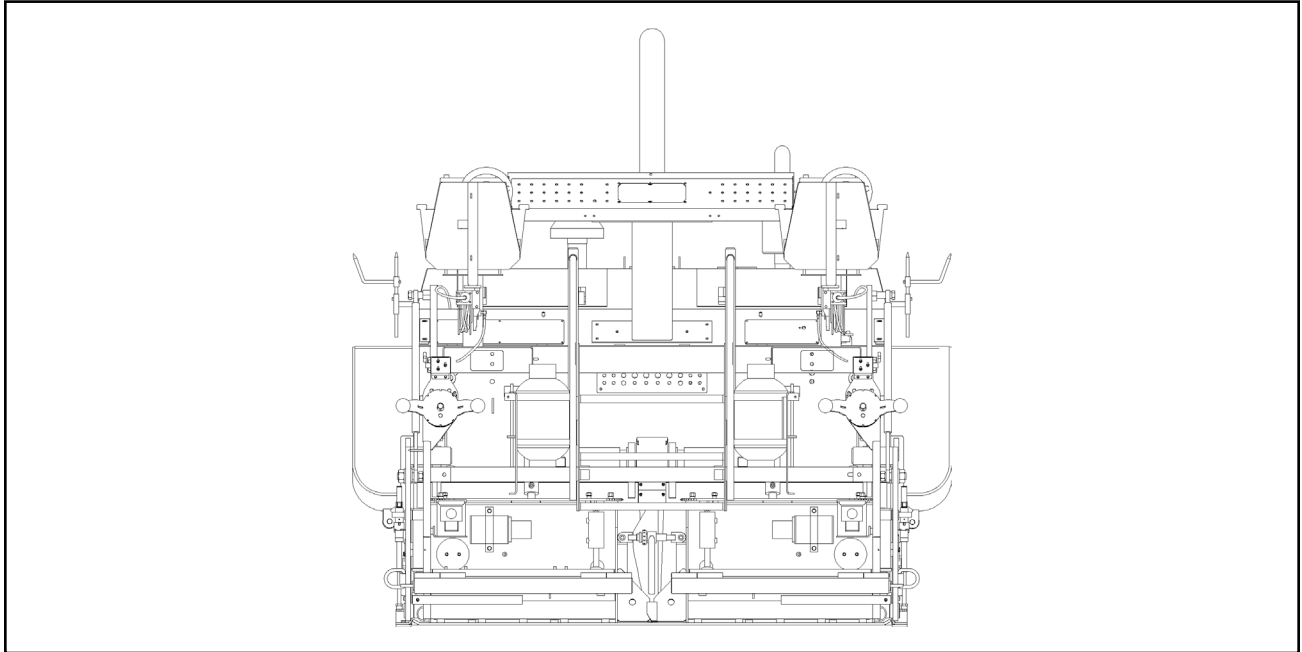
**MODEL 8816 CONVEYOR PAVER
OPERATORS, MAINTENANCE AND PARTS MANUAL****REAR VIEW**

This manual should be used with all related supplemental books, engine and transmission manuals, and parts books. Related Service Bulletins should be reviewed to provide information regarding some of the recent changes.

If any questions arise concerning this publication or others, contact your local

LeeBoy Distributor for the latest available information.

Contents of this manual are based on information in effect at the time of publication and are subject to change without notice.

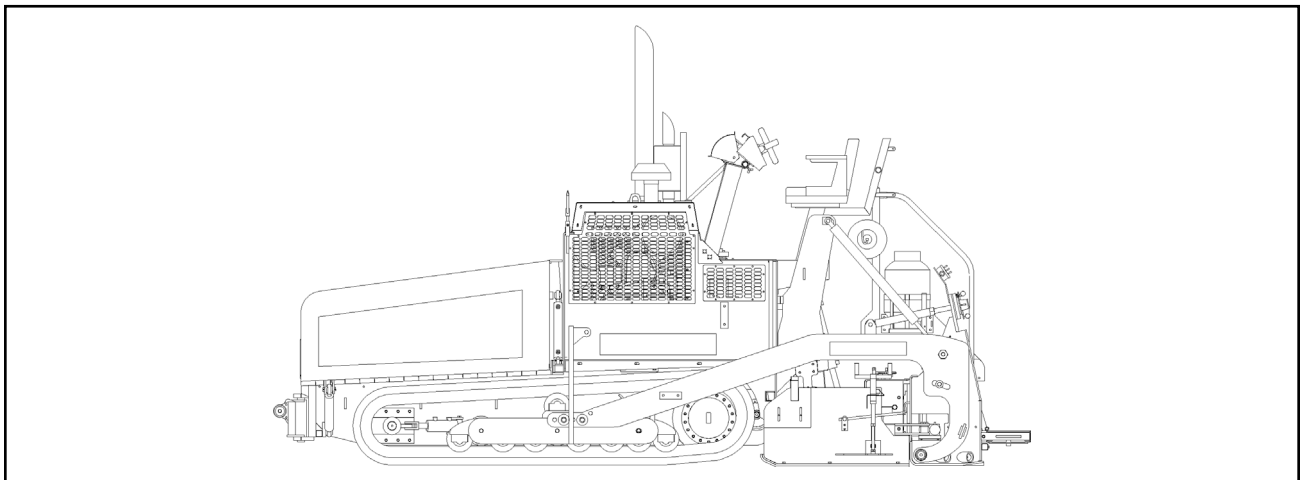
**SIDE VIEW**

IMPORTANT

SAFETY INSTRUCTIONS

This manual provides important information to familiarize you with safe operating and maintenance procedures. Even though you may be familiar with similar equipment, you **MUST** read and understand this manual before operating this unit.

Safety is everyone's business and is one of your primary concerns. Knowing the guidelines covered in the following paragraphs and in Section 1 will help

provide for your safety, for the safety of those around you, and for the paver's proper operation.

LOOK FOR THESE SYMBOLS WHICH POINT OUT ITEMS OF EXTREME IMPORTANCE TO YOU AND YOUR COWORKERS SAFETY. READ AND UNDERSTAND THOROUGHLY. HEED THE WARNING AND FOLLOW THE INSTRUCTIONS.

DANGER

YOU MUST FOLLOW ALL DANGER SAFETY NOTES. IF YOU DO NOT FOLLOW THE INSTRUCTIONS, YOUR MISTAKE MIGHT LIKELY RESULT IN VERY SERIOUS INJURY OR DEATH.

WARNING

WARNING safety notes must ALSO be followed. Your mistake might result in SERIOUS INJURY to yourself or others.

CAUTION

CAUTION safety notes are ALSO very important. They point out to you where your mistakes could cause PHYSICAL HARM to you or others, or damage to the machine.

SAFETY PRECAUTIONS

If your paver has been repainted, it is extremely important that all the decals referring to cautions, warnings, and danger be replaced in their proper locations. The illustrations on this page will aid you in determining the proper locations. However for additional help, you should refer to the parts listing in the parts section of this manual and note the description column.

Under this column a description on location is provided for each decal. If you still need more explicit instructions, contact your dealer.

NOTE

It is the responsibility of the owner and operator to make sure that all decals are readable and located on paver as designated by the manufacturer.

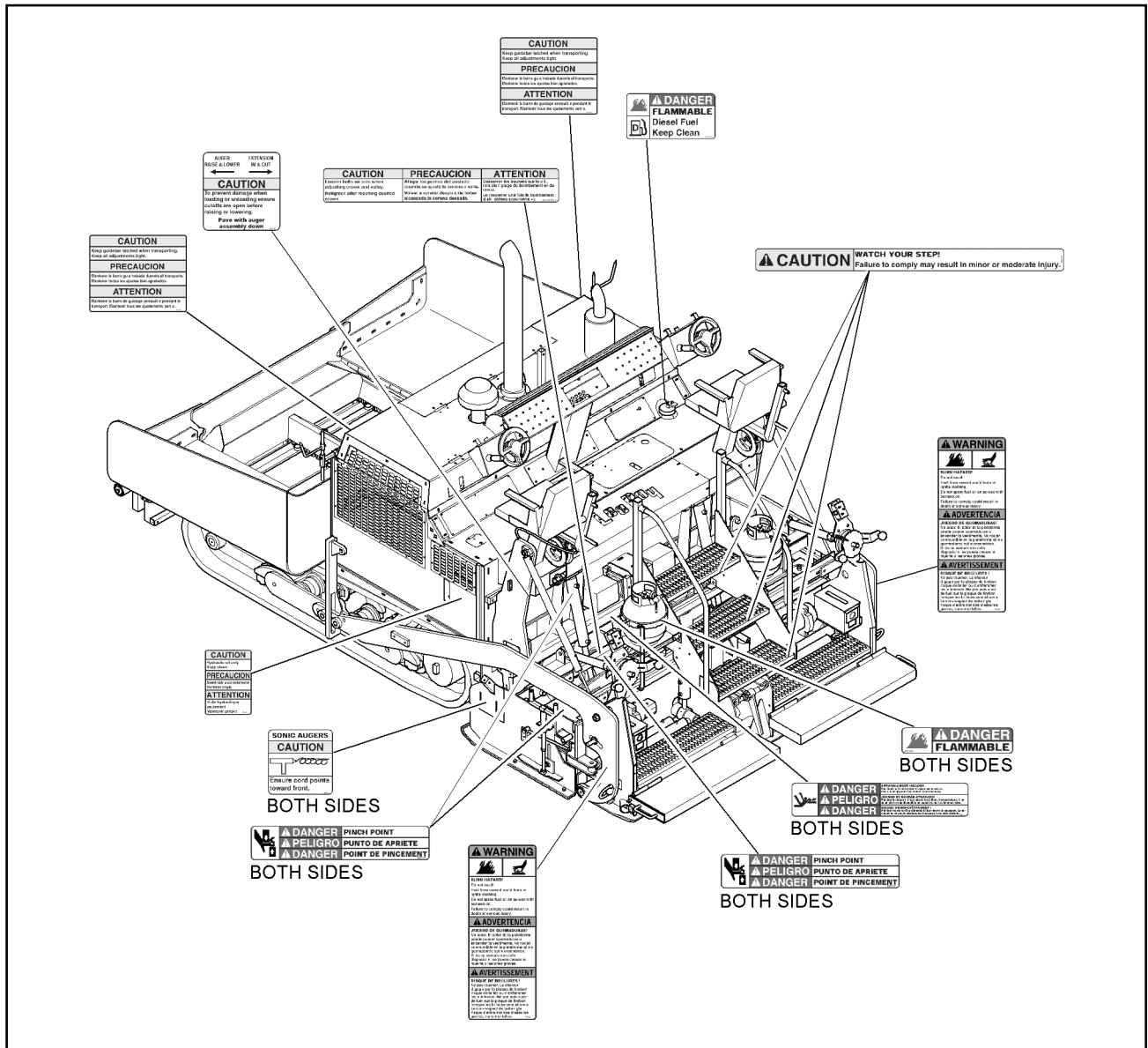

8816 DECALS and DECAL LOCATIONS

8816 CONVEYOR PAVER



PRE-START INSPECTION

INSPECT machine. Have any malfunctioning, broken or missing parts corrected or replaced before using. Hydraulic hoses should be checked daily for wear and leaks. Replace if damaged.

CHECK that all the instruction and safety labels are in place and readable. These are as important as any other equipment on the machine.

READ and FOLLOW all instruction decals.

WEAR OSHA required safety equipment when running the paver.

FILL the fuel tank with the engine off. Never fill fuel tank near an open flame, when smoking, or when screed heat is on.

CLEAR auger & feeders before starting engine. Make sure all covers and guards are in place.

OPERATING SAFETY

ALWAYS make sure no person or object is in your line of travel BEFORE starting.

WORK slowly in tight areas.

DO NOT run engine in a closed building for long periods of time. NEVER spray cleaning solvent or release agent on or near screed while it is being heated.

AVOID steep hills if possible.

ALWAYS look BEFORE changing your direction of travel.

NEVER open a valve to burner unless a flame is present. Heat screed for no more than 15 minutes. Make sure all valves are closed before propane is turned on.

AVOID leaving engine running without operator present.

STOPPING SAFETY

ALWAYS park the paver on solid, level ground in low range. If this is not possible, always park the paver at a right angle to the slope. Lower screed when parked.

USE proper flags, barriers and warning devices especially when parking in areas of traffic.

MAINTENANCE SAFETY

NEVER work on the paver with the engine running.

NEVER fill the fuel tank with the engine running.

DO NOT change the engine governor settings.

ALWAYS replace damaged or lost decals.

DISCONNECT battery cables when working on the electrical system or when welding on the unit.

IF battery needs a charge, be sure battery charger is off when making connections.

BE SURE the correct battery polarity is observed (negative (-) to negative (-) and positive (+) to positive (+)), when connecting a battery charger or jumper cable.



TABLE OF CONTENTS

	Page
GENERAL INFORMATION1-2
SPECIFICATIONS1-2
CONTROLS AND OPERATING INSTRUCTIONS1-2
MAINTENANCE PROCEDURES1-2
NAMEPLATE1-2

Section 1 INTRODUCTION



GENERAL INFORMATION

This manual contains Specification information, Controls and Operating Procedures, Maintenance and Repair Procedures and Parts Lists for the Model 8816 Conveyor Paver.

SPECIFICATIONS

Refer to Section 2 - SPECIFICATIONS in this manual for all major system specifications and for typical torque value tables.

CONTROLS AND OPERATING INSTRUCTIONS

Refer to Section 3 - OPERATION.

The operator of this equipment should READ, UNDERSTAND, and FOLLOW the operating instructions, Cautions, and Warnings provided in the front of this manual and in the OPERATION section.

WARNING: Do not attempt to operate the Model 8816 Conveyor Paver unless fully trained in the machine operation, only authorized personnel should operate the Model 8816 Conveyor Paver. All instructions provided in this manual and on the machine decals must be followed to prevent damage to the equipment and/or injury to operating personnel.



MAINTENANCE PROCEDURES

Refer to Section 4 - MAINTENANCE in this manual for all maintenance and repair procedures.

CAUTION: All maintenance instructions provided in this manual should be followed to insure safety of the personnel performing the maintenance and to prevent damage to the machine.



NAMEPLATE

The Nameplate, (see Figure 1-1), contains the serial number and basic data used to identify the specific model on the conveyor paver.

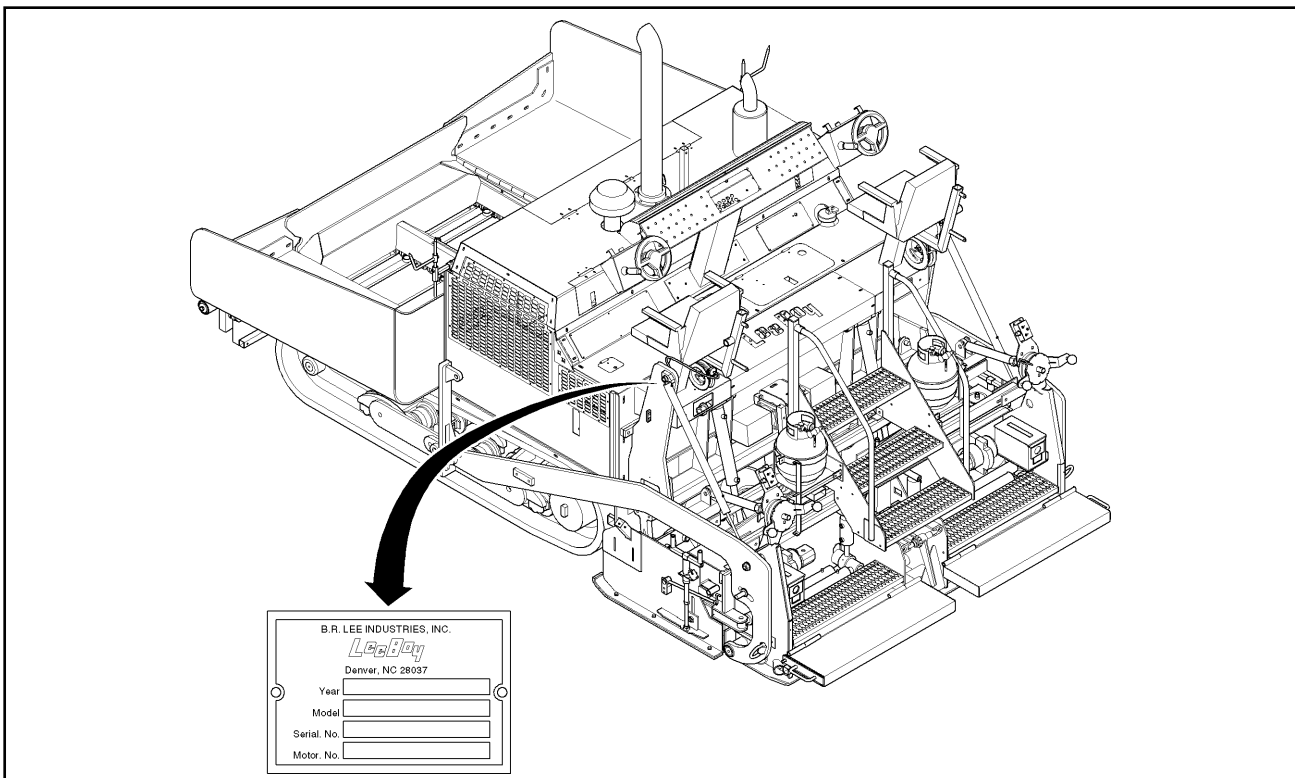

FIGURE 1-1. NAME PLATE

TABLE OF CONTENTS

	Page
GENERAL INFORMATION	2-2
TABLE 2-1. ENGINE SPECIFICATIONS	2-2
TABLE 2-2. ELECTRICAL SPECIFICATIONS.	2-2
TABLE 2-3. DIMENSION SPECIFICATIONS	2-3
TABLE 2-4. PERFORMANCE SPECIFICATIONS.	2-3
TABLE 2-5. MACHINE SYSTEM CAPACITY SPECIFICATIONS.	2-4
TABLE 2-6. SCREED.	2-4
TABLE 2-7. WASHDOWN SYSTEM.	2-4
TABLE 2-8. HYDRAULIC SYSTEM.	2-5
TABLE 2-9. MACHINE HYDRAULIC PRESSURES.	2-5
TABLE 2-10. TYPES OF LUBRICANTS.	2-5
TABLE 2-11. TORQUE SPECIFICATIONS FOR STANDARD INCH FASTENERS.	2-6
TABLE 2-12. TORQUE SPECIFICATIONS FOR METRIC FASTENERS	2-7

Section 2 SPECIFICATIONS



GENERAL INFORMATION

The specifications provided in this section are applicable to the Model 8816 Conveyor Paver. Included in this section are machine weights, dimensions, performance, and torque values for both metric and standard inch fasteners.

TABLE 2-1. ENGINE SPECIFICATIONS

ITEM	CHARACTERISTIC
ENGINE	
Model and Manufacturer	130 HP (97 kW) Cummins
Type	4 Cycle diesel
Number of Cylinders	Four
Bore & Stroke	4.02 in. (102 mm) x 4.72 in. (120 mm)
Engine Oil Type	10W-40
Capacity	11.5 Quarts (10.9 liter)
ENGINE COOLING SYSTEM	
Type	Water Cooled
ENGINE FUEL	
Type Used	Diesel Fuel
Fuel Capacity	30 gallons (111 liters)
FUEL FILTER	
Type	Cummins

TABLE 2-2. ELECTRICAL SPECIFICATIONS

ITEM	CHARACTERISTIC
BATTERY	
Number Per Machine	Two maintenance free
Ampere Hour Rating	670 CCA
Voltage	12 Volts
ALTERNATOR	
Voltage	12 Volt, negative ground
Output Amperage	50 Amps
Fan Belt Tension	Belt tension mechanism keeps serpentine belt under tension at all times
STARTER	
Manufacturer	(See Engine Starter plate)
Voltage and Type	12 Volt, negative ground
Rating	2.7 kW

TABLE 2-3. DIMENSION SPECIFICATIONS [See Figure 2-1]

ITEM	SPECIFICATION
DIMENSIONS	
Overall Length	17' (5.18 m)
Overall Height	9' (2.74 m)
Overall Width (hopper wings in)	8' 6" (2.59 m)
Overall Width (hopper wings out)	10' (3.05 m)
Weight	25,000 lbs (11,3384 kg)

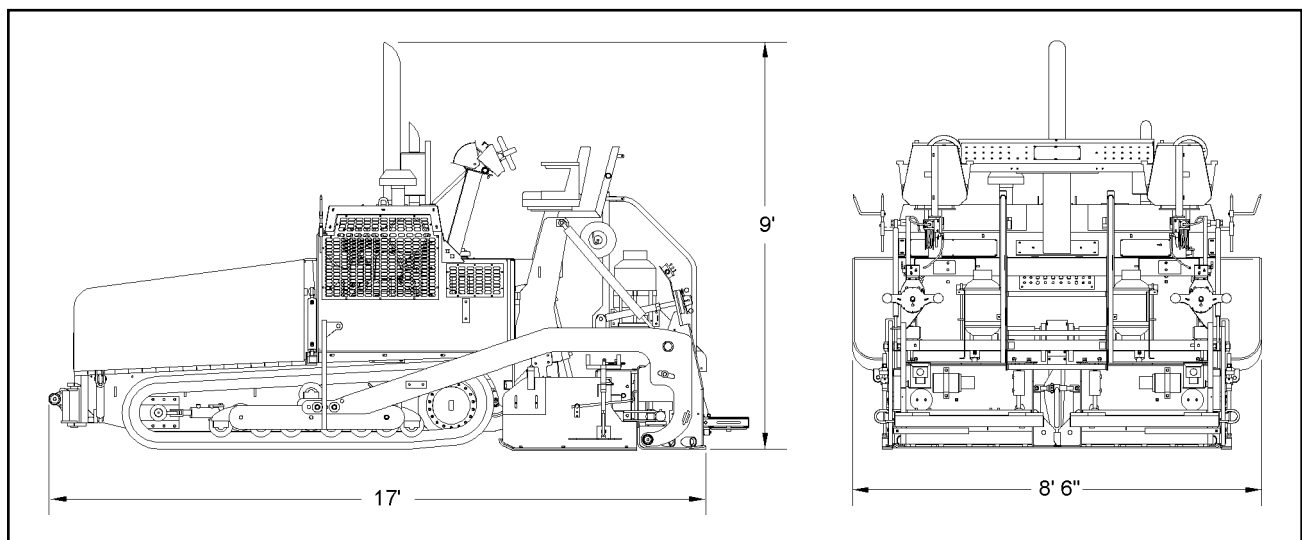

FIGURE 2-1. OUTLINE DIMENSIONAL DRAWING

TABLE 2-4. PERFORMANCE SPECIFICATIONS

ITEM	SPECIFICATION
SPEED	
Travel	0 - 360 FPM (0 - 0.109 KPM)
Paving	0 - 140 FPM (0 - 0.043 KPM)
EFFECTIVE COVERAGE	
Basic Screed Width	8 ft. (2.44 m)
Maximum Screed Width	15 ft. 6 in. (4.75 m)

Section 2 SPECIFICATIONS



TABLE 2-5. MACHINE SYSTEM CAPACITY SPECIFICATIONS

ITEM	SPECIFICATION
SYSTEM CAPACITIES	
Fuel	30 gallons (111 liters)
Engine Lubrication Oil	12 quarts (11.35 liters) (with lubrication oil filter)
Hydraulic Oil Reservoir	50 gallons (189 liters)
Torque Hubs	32 ounces (0.355 liters) each
Propane	Two (2) 20 lb tanks

TABLE 2-6. SCREED

ITEM	SPECIFICATION
Heat	Four 54,000 BTU propane burners on main screed Each extension has one 54,000 BTU propane burner
Extensions	Two 45 inch hydraulically operated extensions
Vibration	Two hydraulic vibrators producing 3400 vibrations per minute
Crown/Invert	Adjustable, at least 2 inches of crown and 1-1/2 inches of valley Includes a level indicator

TABLE 2-7. WASHDOWN SYSTEM

ITEM	SPECIFICATION
Components	Electric pump with two (2) hose reels with a 15 foot x 5/16 inch hose

TABLE 2-8. HYDRAULIC SYSTEM

ITEM	SPECIFICATION
Drives and Conveyor/Auger	Variable volume hydraulic proportional pump for each
Fumes and Vibrator	Constant volume pump
All other Hydraulic Functions	Pressure comp pump
Hydraulic Oil Reservoir w/oil cooler50 gallons [189 liters]

TABLE 2-9. MACHINE HYDRAULIC PRESSURES

ITEM	SPECIFICATION
Drive3300 PSI (228 Bar)
Conveyors/Auger3300 PSI (228 Bar)
Cylinders1800 PSI (124 Bar)
Vibrator/Blower1800 PSI (124 Bar)
Track Tension900 PSI (62 Bar)
Track Tension (Relieving)1200 PSI (83 Bar)
Charge Pressure200/250 PSI (14/17 Bar)

TABLE 2-10. TYPES OF LUBRICANTS

ITEM	SPECIFICATION
Engine Oil10W-40
Hydraulic OilAW #68
Torque Hub Grease90 WT Gear Lub
GreaseShell Avania EP Grease or Equivalent
Chain LubChain Lub

Section 2 SPECIFICATIONS



TABLE 2-11. TORQUE SPECIFICATIONS FOR STANDARD INCH FASTENERS

WARNING: The following Table lists torque values for standard hardware and are intended as a guide for average application involving typical stresses and machined surfaces. Values are based on physical limitations of clean, plated and lubricated hardware. In all cases, when an individual torque value is specified, it should be followed instead of values given in this table.



CAUTION: Replace original equipment with hardware of equal grade.



		CAPSCREWS: SAE GRADE 5				CAPSCREWS: SAE GRADE 8			
SIZE	THREAD	TORQUE FT. LBS.		TORQUE N•m		TORQUE FT. LBS.		TORQUE N•m	
		Dry	Lubed	Dry	Lubed	Dry	Lubed	Dry	Lubed
1/4	20 UNC	8	6	11	9	12	9	16	12
	28 UNF	10	7	13	10	14	10	19	14
5/16	18 UNC	17	13	24	18	25	18	33	25
	24 UNF	19	14	26	20	27	20	37	28
3/8	16 UNC	31	23	42	31	44	33	59	44
	24 UNF	35	26	47	36	49	37	67	50
7/16	14 UNC	49	37	67	50	70	52	95	71
	20 UNF	55	41	75	56	78	58	105	79
1/2	13 UNC	75	57	100	77	105	80	145	110
	20 UNF	85	64	115	86	120	90	165	120
9/16	12 UNC	110	82	145	110	155	115	210	155
	18 UNF	120	91	165	125	170	130	230	175
5/8	11 UNC	150	115	205	155	210	160	285	215
	18 UNF	170	130	230	175	240	180	325	245
3/4	10 UNC	265	200	360	270	375	280	510	380
	16 UNF	295	225	405	300	420	315	570	425
7/8	9 UNC	430	320	580	435	605	455	820	615
	14 UNF	475	355	640	480	670	500	905	680
1	8 UNC	645	485	875	655	910	680	1230	925
	14 NF	720	540	980	735	1020	765	1380	1040
1-1/8	7 UNC	795	595	1080	805	1290	965	1750	1310
	12 UNF	890	670	1210	905	1440	1080	1960	1470
1-1/4	7 UNC	1120	840	1520	1140	1820	1360	2460	1850
	12 UNF	1240	930	1680	1260	2010	1500	2730	2050
1-3/8	6 UNC	1470	1100	1990	1490	2380	1780	3230	2420
	12 UNF	1670	1250	2270	1700	2710	2040	3680	2760
1-1/2	6 UNC	1950	1460	2640	1980	3160	2370	4290	3210
	12 UNF	2190	1650	2970	2230	3560	2670	4820	3620

TABLE 2-12. TORQUE SPECIFICATIONS FOR METRIC FASTENERS

WARNING: The following Table lists torque values for standard hardware and are intended as a guide for average application involving typical stresses and machined surfaces. Values are based on physical limitations of clean, plated and lubricated hardware. In all cases, when an individual torque value is specified, it should be followed instead of values given in this table.



CAUTION: Replace original equipment with hardware of equal grade.



NOMINAL SIZE & PITCH	CLASS 8.8 [GRADE 5 EQUIVALENT]				CLASS 10.9 [GRADE 8 EQUIVALENT]			
	TORQUE FT. LBS.		TORQUE N•m		TORQUE FT. LBS.		TORQUE N•m	
	Dry	Lubed	Dry	Lubed	Dry	Lubed	Dry	Lubed
M4 x 0.7	2.27	1.70	3.07	2.30	2.27	2.31	4.17	3.13
M5 x 0.8	4.58	3.43	6.20	4.65	6.22	4.67	8.43	6.33
M6 x 1	7.75	5.83	10.5	7.90	10.60	7.97	14.3	10.8
M8 x 1.25	18.89	14.17	25.6	19.2	18.95	19.26	34.8	26.1
M10 x 1.25	39.11	29.52	53.0	40.1	53.87	40.59	73.0	55.0
M12 x 1.75	64.94	48.71	88.0	66.0	88.56	66.42	120.0	90.0
M14 x 2	103.32	77.49	140.0	105.0	140.22	107.01	190.0	145.0
M16 x 2	162.36	121.77	220.0	165.0	221.40	166.05	300.0	225.0
M20 x 2.5	317.34	236.16	430.0	320.0	428.04	321.03	580.0	435.0
M24 x 3	516.12	409.59	740.0	555.0	754.38	557.19	1010.0	755.0
M27 x 3	797.04	597.78	1080.0	810.0	1084.86	811.80	1470.0	1100.0
M30 x 3.5	1084.86	811.80	1470.0	1100.0	1476.00	1107.00	2000.0	1500.0

TABLE OF CONTENTS

	Page
GENERAL INFORMATION	3-2
OPERATING CONTROLS, INDICATORS, AND GAUGES	3-2
OPERATION	3-18
SAFETY	3-18
Operating Safety	3-18
Stopping Safety	3-18
Maintenance Safety	3-18
PRE-START INSPECTION	3-18
STARTING THE ENGINE	3-18
Preliminary	3-18
Engine Start-up	3-19
Stopping the Engine	3-19
PAVER DRIVING INSTRUCTIONS	3-19
General	3-19
Electronic Control Steering Box	3-19
PAVER PREPARATION INSTRUCTIONS	3-20
Burner Ignition Procedures	3-20
General	3-20
TRUCK HITCH ATTACHMENT	3-21
GENERAL	3-21
OPERATING FEEDER	3-21
GENERAL	3-21
OPERATING TOW POINT CYLINDERS	3-22
GENERAL	3-22
OPERATING HYDRAULIC CUTOFF GATES	3-22
GENERAL	3-23
ELECTRIC SPRAY DOWN	3-23
GENERAL	3-23
AUGERS	3-23
SONIC AUGERS	3-23
General	3-23
Operating From Left Operators Seat	3-24
Operating From Right Operators Seat	3-25
Manual Operation	3-25
Raising and Lowering Augers	3-26
Auger/Conveyor and Drive Micros	3-26
LOADING AND UNLOADING	3-27
GENERAL	3-27
UNLOADING	3-27
LOADING	3-27
TIE DOWN PROCEDURE	3-29
PAVING PREPARATION INSTRUCTIONS	3-29
STARTING TO PAVE	3-30
GENERAL	3-30
SETTING SCREED TO PAVE	3-30
SETTING SCREED ENDGATES	3-32
SETTING SCREED EXTENSIONS	3-32
PAVER OPERATION	3-33

Section 3 OPERATION



GENERAL INFORMATION

This section provides the Operating Instructions for the Model 8816 Conveyor Paver.

It is important to read, understand, and follow all "Precautions Operating Instructions and Warnings" written in this manual before starting or operating the machine.

DANGER: Failure to observe the "Operating Precautions and Warning Instructions" provided in this manual can cause serious injury or death. Only authorized personnel, who are fully trained in the machine operation, can operate the Model 8816 Conveyor Paver.



This machine should be kept in good mechanical condition at all times.

WARNING: Do not operate a machine needing repairs. Put an information tag on the instrument panel that says, "DO NOT OPERATE". Remove the key from the ignition switch. Repair all damage at once. Minor damage can result in major system failures.



OPERATING CONTROLS, INDICATORS, AND GAUGES

Operating controls for the Model 8816 Conveyor Paver are shown in Figures 3-1 through 3-5 and listed in Table 3-1.

WARNING: Do not start or operate the Model 8816 Conveyor Paver before reading, understanding, and following all information given in this section and shown on the machine. The operators must read and understand the function of all controls, indicators, and gauges before starting the engine. Serious injury or death can result if these procedures are not followed.



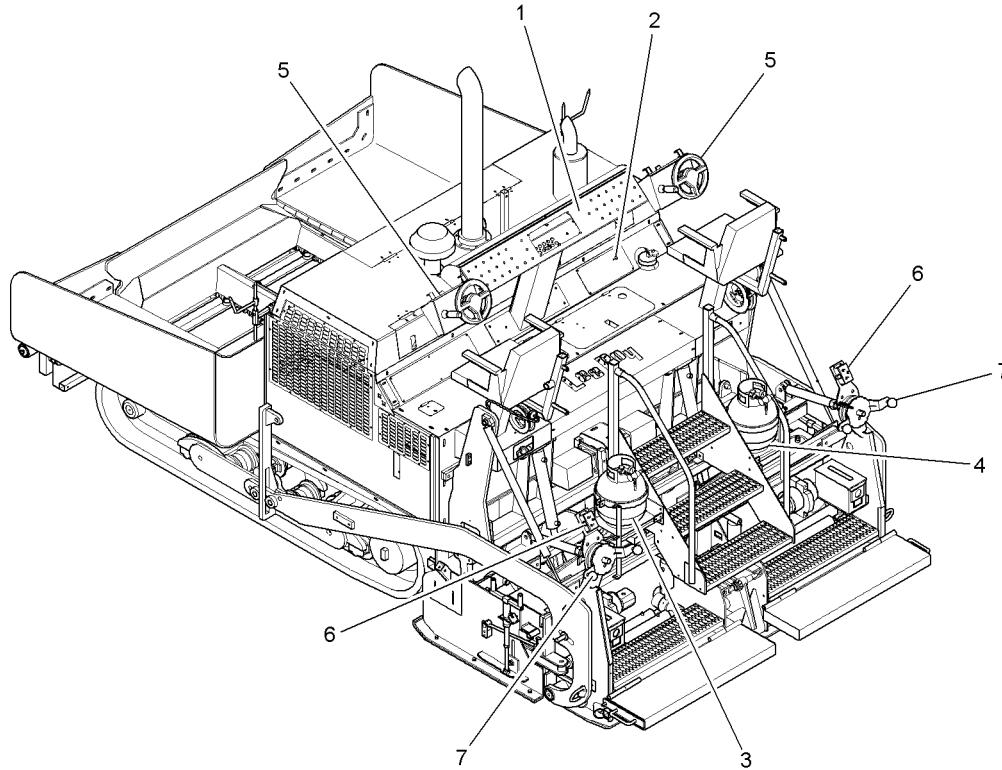

FIGURE 3-1. LOCATION OF CONTROLS

TABLE 3-1. OPERATING CONTROLS, INDICATORS, AND GAUGES

FIG. REF	ITEM NO.	CONTROL NAME	TYPE	FUNCTION
3-1	1	Instrument (Dash) Panel		Contains switches, indicators, and gauges (see Figure 3-2).
3-1	2	Master Switch	Manual rotary 2-position switch	Disconnects battery in OFF position. Connects battery in ON position. (Ground) NOTE: Always turn switch to OFF position at the end of the day or when welding.
3-1	3	Left Burner Control		Controls flow of propane to left screed burners.
3-1	4	Right Burner Control		Controls flow of propane to right screed burners.
3-1	5	Steering And Speed Control Modules		Contains the controls for Steering and Speed Control (see Figure 3-3).
3-1	6	Left And Right Auger Boxes		Contains Auger, Conveyor, Extension, and slope controls.
3-1	7	Flight Screw		Manually adjusts material depth.

Section 3 OPERATION

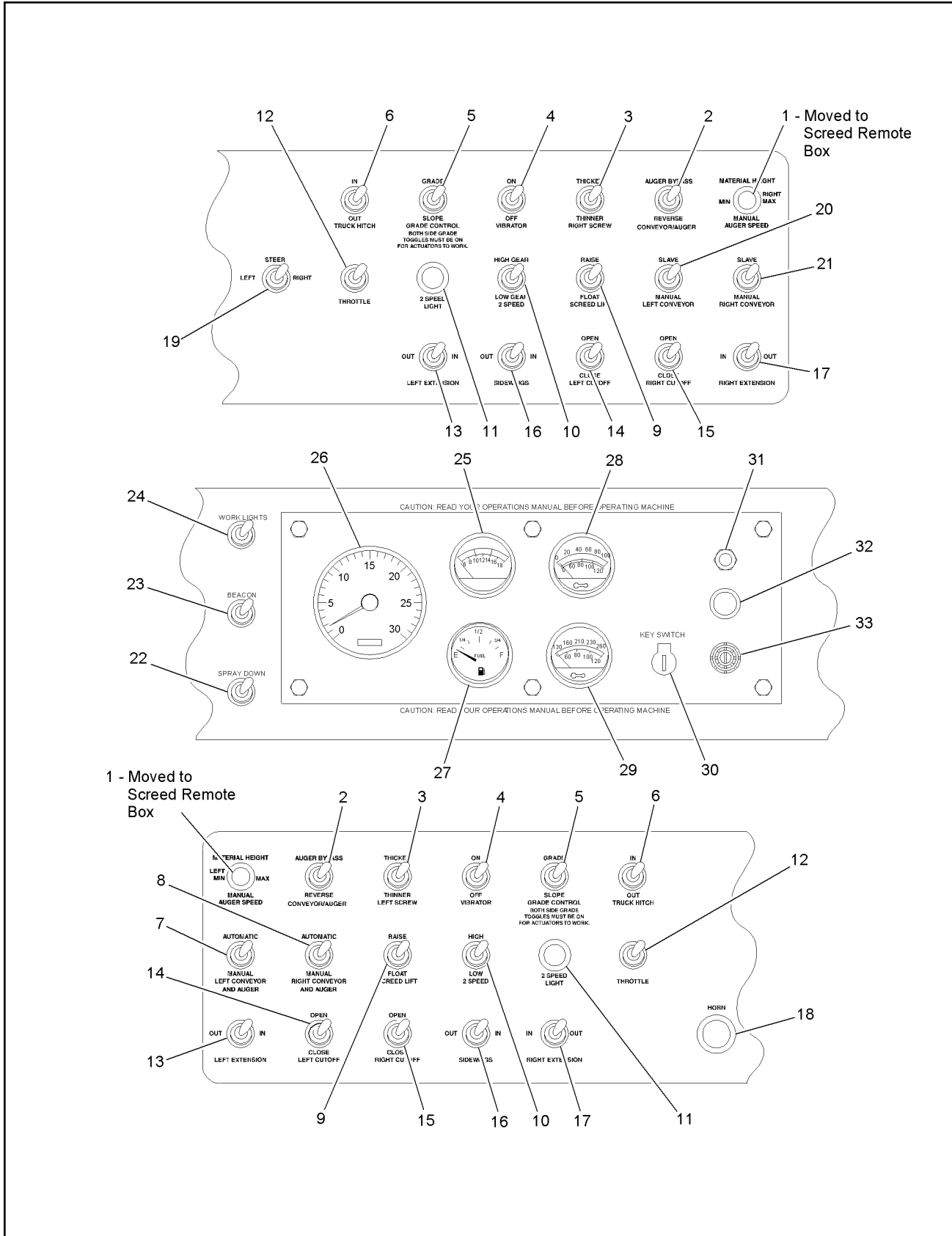

FIGURE 3-2. INSTRUMENT (DASH) PANEL CONTROLS, INDICATORS, AND GAUGES

TABLE 3-1. OPERATING CONTROLS, INDICATORS, AND GAUGES (CONTINUED)

FIG. REF	ITEM NO.	CONTROL NAME	TYPE	FUNCTION
3-2	1	RIGHT and LEFT MATERIAL HEIGHT and MANUAL AUGER SPEED Switch		NOT USED
3-2	2	AUGER BYPASS and REVERSE CONVEYOR/AUGER Switch	3-Position toggle switch	<p>Conveyor/Auger Switch is used for filling hopper as full as you want and keeps augers from augering material out on each end. For normal operation, the switch should be in the center position.</p> <p>In the AUGER BYPASS (Up) position stops the auger from turning.</p> <p>In the REVERSE (Down) position reverses the auger/conveyor rotation.</p>
3-2	3	RIGHT and LEFT SCREW THICKER/ THINNER Switch	3-Position toggle switch	<p>Sets the thickness of the asphalt.</p> <p>Place switch in THICKER position for thicker asphalt.</p> <p>Place switch in THINNER position for thinner asphalt.</p> <p>NOTE: The GRADE CONTROL switch (Item 5) on both the left and right dash must be set to GRADE to turn power on.</p> <p>NOTE: Control functions only when joystick is forward.</p>

Section 3 OPERATION



TABLE 3-1. OPERATING CONTROLS, INDICATORS, AND GAUGES (CONTINUED)

FIG. REF	ITEM NO.	CONTROL NAME	TYPE	FUNCTION
3-2	4	VIBRATOR ON/OFF Switch	2-Position toggle switch	Turns the screed vibrator on or off. In ON position helps compact material. NOTE: Control functions only when joystick is forward.
3-2	5	GRADE CONTROL Switch	2-Position toggle switch	When switch is in the GRADE position, power is present only when the joystick is in the FORWARD position. In the SLOPE position of the GRADE Control switch, all power is turned off. NOTE: When running Automatic Grade Controls turn power off with this switch at the end of mat being laid.
3-2	6	TRUCK HITCH IN/OUT (Optional Switch)	3-Position toggle switch (momentary)	Used to engage the truck hitch to the truck wheels. Set switch to IN position to engage the hitch. Set switch to the OUT position to release the hitch from the truck wheels.
3-2	7	LEFT CONVEYOR AND AUGER AUTOMATIC/MANUAL Switch	3-Position stays in AUTO or MANUAL position	Selects automatic or manual override for left conveyor. Center is OFF position. For automatic operation set switch to AUTOMATIC position. Conveyor can be operated from left or right side dash. MANUAL position provides MANUAL override (Potentiometer controls speed). NOTE: All other auger switches must also be in the ON position.
3-2	8	RIGHT CONVEYOR AND AUGER AUTOMATIC/MANUAL Switch	3-Position stays in AUTO or MANUAL position	Selects automatic or manual override for right conveyor. Center is OFF position. For automatic operation set switch to AUTOMATIC position. Conveyor can be operated from left or right side dash. MANUAL position provides MANUAL override (Potentiometer controls speed). NOTE: All other auger switches must also be in the ON position.

TABLE 3-1. OPERATING CONTROLS, INDICATORS, AND GAUGES (CONTINUED)

FIG. REF	ITEM NO.	CONTROL NAME	TYPE	FUNCTION
3-2	9	SCREED LIFT RAISE/FLOAT Switch	3-Position toggle switch	<p>Used to raise or float the screed. Center position is HOLD. Spring loaded to Center in Raise. Detents in for Float. Center holds the screed position. To raise the screed, set switch to RAISE position. To float the screed, set switch to FLOAT position.</p> <p>NOTE: Switch must be in FLOAT to pave.</p> <p>NOTE: Either left or right side can run independently.</p> <p>NOTE: Run from one side at a time. The other side needs to be in center position or screed will not Raise.</p>
3-2	10	2-SPEED HIGH/LOW Switch	2-Position toggle switch	<p>Used to change machine speed. Place switch in LOW position for work. HIGH is only used for travel. For low speed operation both left and right switches must be in LOW. Place switch in HIGH position for travel. (When in TRAVEL red 2-SPEED LIGHT (Item 11) will illuminate.)</p> <p>IMPORTANT: High speed is only for traveling. Never pave in high speed.</p>
3-2	11	2-SPEED LIGHT		<p>Illuminates to indicate when 2-SPEED switch is in the HIGH position.</p>
3-2	12	THROTTLE Switch	3-Position toggle switch	<p>Used to set the engine RPM. Push THROTTLE up for higher RPM. Push THROTTLE down for lower RPM.</p>

Section 3 OPERATION



TABLE 3-1. OPERATING CONTROLS, INDICATORS, AND GAUGES (CONTINUED)

FIG. REF	ITEM NO.	CONTROL NAME	TYPE	FUNCTION
3-2	13	LEFT EXTENSION OUT/IN Switch	3-Position toggle switch	Used to move the left extension in or out. Push switch to OUT position to move left extension out. Push switch to IN position to move left extension in. NOTE: LEFT EXTENSION switch also located on Auger Box on left side of machine.
3-2	14	LEFT CUTOFF OPEN/CLOSE Switch	3-Position toggle switch	Used to open or close the left cutoff. Set switch to the OPEN position to open left cutoff. Set switch to CLOSE position to close left cutoff. NOTE: Cutoff can be operated from either side of the dash.
3-2	15	RIGHT CUTOFF OPEN/CLOSE Switch	3-Position toggle switch	Used to open or close the right cutoff. Set switch to the OPEN position to open right cutoff. Set switch to CLOSE position to close right cutoff. NOTE: Cutoff can be operated from either side of the dash.
3-2	16	SIDE WINGS OUT/IN Switch	3-Position toggle switch	Used to move the side wings in or out. Push switch to OUT position to move side wings out. Push switch to IN position to move side wings in.
3-2	17	RIGHT EXTENSION IN/OUT Switch	3-Position toggle switch	Used to move the right extension in or out. Push switch to OUT position to move right extension out. Push switch to IN position to move right extension in. NOTE: RIGHT EXTENSION switch also located on Auger Box on right side of machine.

TABLE 3-1. OPERATING CONTROLS, INDICATORS, AND GAUGES (CONTINUED)

FIG. REF	ITEM NO.	CONTROL NAME	TYPE	FUNCTION
3-2	18	HORN Switch	Push button switch	Press button to sound the horn.
3-2	19	STEER LEFT/RIGHT Switch	2-Position toggle switch	<p>Select the operable steering control.</p> <p>Set switch to LEFT when steering from the left side of the machine.</p> <p>Set switch to RIGHT when steering from the right side of the machine.</p> <p>NOTE: Steering can only be performed from one side at a time, depending on the position of the LEFT/RIGHT switch.</p>
3-2	20	LEFT CONVEYOR SLAVE/MANUAL Switch	3-Position center return toggle switch From Manual Position	<p>Selects slave or manual operation of left auger.</p> <p>Center position for Off.</p> <p>SLAVE POSITION FOR AUTOMATIC operation.</p> <p>MANUAL position provides manual override (momentary).</p> <p>NOTE: If running from right side, leave switches on left side in AUTO position at all times.</p> <p>NOTE: In order for sonic augers or manual to work, both LEFT and RIGHT CONVEYOR switches must be in the SLAVE position and the LEFT and RIGHT CONVEYOR AND AUGER switches on the left side dash must be in the AUTOMATIC position, plus the LEFT and RIGHT AUGER Switch on Lower Screed Remote Boxes have to be on.</p>

Section 3 OPERATION



TABLE 3-1. OPERATING CONTROLS, INDICATORS, AND GAUGES (CONTINUED)

FIG. REF	ITEM NO.	CONTROL NAME	TYPE	FUNCTION
3-2	21	RIGHT CONVEYOR SLAVE/MANUAL Switch	3-Position automatic center return toggle switch From Manual Position	<p>Selects slave or manual operation of right auger.</p> <p>Center position for Off.</p> <p>SLAVE position for Automatic Operation.</p> <p>MANUAL position provides manual override (momentary).</p> <p>NOTE: If running from right side, leave switches on left side in AUTO position at all times.</p> <p>NOTE: In order for sonic augers or manual to work, both LEFT and RIGHT CONVEYOR switches must be in the SLAVE position and the LEFT and RIGHT CONVEYOR AND AUGER switches on the left side dash must be in the AUTOMATIC position, plus the LEFT and RIGHT AUGER switches on Lower Screed Remote Boxes have to be on.</p>
3-2	22	SPRAY DOWN Switch	2-Position toggle switch	<p>Used to turn on the Spray Down System.</p> <p>Set switch to SPRAY DOWN position to turn spray system on. (Pump tied in to separate tank than Engine)</p>
3-2	23	BEACON Switch	2-Position toggle switch	<p>Used to turn the beacon light on or off.</p> <p>Set switch to BEACON position to turn the Beacon light on.</p>
3-2	24	WORK LIGHTS Switch	2-Position toggle switch	<p>Used to turn the work lights on or off.</p> <p>Set switch to WORK LIGHTS position to turn the work lights on.</p>
3-2	25	Voltmeter		Indicates battery voltage.
3-2	26	Tachometer		Indicates engine speed (2250 max).
3-2	27	Fuel Gauge		Indicates amount of fuel in fuel tank.

TABLE 3-1. OPERATING CONTROLS, INDICATORS, AND GAUGES (CONTINUED)

FIG. REF	ITEM NO.	CONTROL NAME	TYPE	FUNCTION
3-2	28	Oil Pressure Gauge		Indicates oil pressure.
3-2	29	Water Temperature Gauge		Indicates engine water temperature.
3-2	30	KEY Switch	Key operated rotary 3-position switch	<p>Controls starting, stopping, and running of engine.</p> <p>Vertical position is OFF. Turn right one notch for power.</p> <p>Far right is the START position. After engine starts release switch, which will automatically return to the power position.</p> <p>NOTE: Engine will not start unless speed control is in NEUTRAL.</p> <p>NOTE: If equipped with Intake heaters Switch must be on, Press heater button for 20 seconds. Engine will not stay running, so turn keyswitch OFF and start up after Murphy shutdown resets.</p>
3-2	31	Reset Switch		Use Reset Switch to reset Ignition Circuit. Circuit will overload if continuous cranking of motor occurs without starting.
3-2	32	Red Indicator Light		Indicates that power is on to panel. When key is in the ON position, light will illuminate on a 12 sec delay.
3-2	33	Speaker		Audible signal works with Red Indicator Light. When key is in the ON position, audible signal will sound on a 12 sec delay.

Section 3 OPERATION

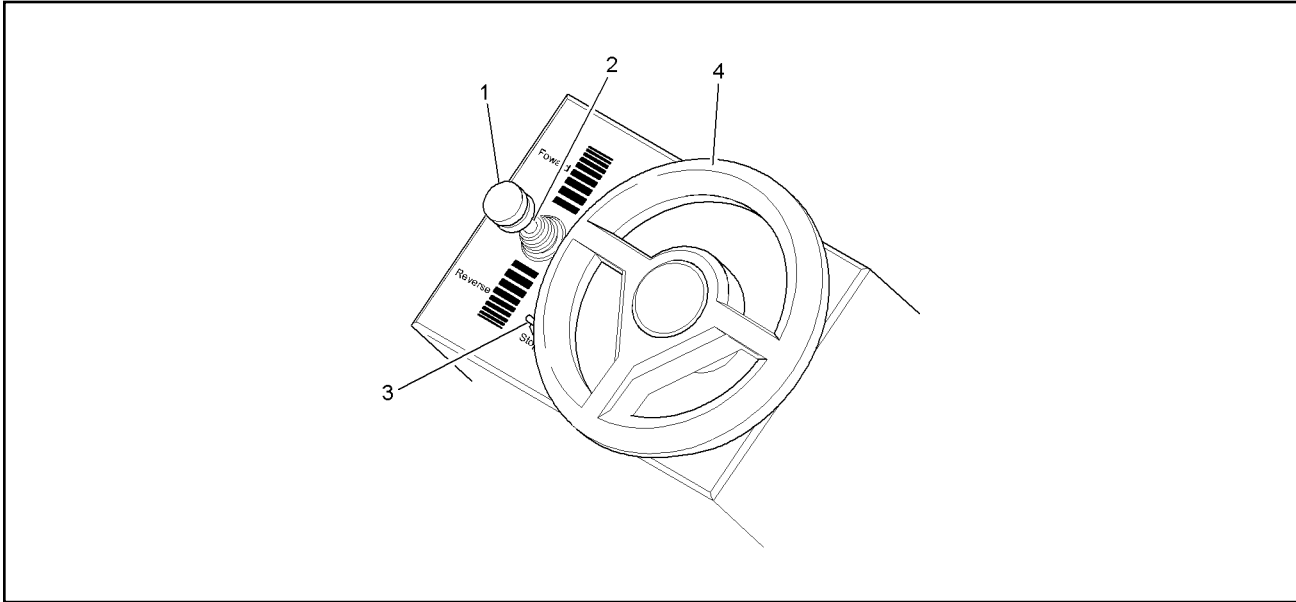

FIGURE 3-3. STEERING AND SPEED CONTROL MODULE

TABLE 3-1. OPERATING CONTROLS, INDICATORS, AND GAUGES (CONTINUED)

FIG. REF	ITEM NO.	CONTROL NAME	TYPE	FUNCTION
3-3	1	Joystick Electronic Steering		Lever controls the speed and direction of travel forward and reverse. Moving joystick forward moves machine forward. The further forward the faster the speed. Moving joystick backward moves machine backward. The further backward the faster the speed. When joystick is centered, the machine is in neutral.
3-3	2	Neutral Lock		This locks the lever in neutral. Pull up on the bottom of the knob to unlock.
3-3	3	RUN/STOP Switch	2-Position toggle switch	Controls stopping the machine while traveling. When switch is set to STOP the machine stops (pauses). When switch is set to RUN the machine resumes its prior speed.
3-3	4	RIGHT STEER/ LEFT STEER Wheel	Rotary control or steering wheel	Used to steer the machine. Rotate wheel slowly toward LEFT STEER to move to the left. Rotate wheel slowly toward RIGHT STEER to move to the right. NOTE: All the way Left or Right machine will Counter Rotate.

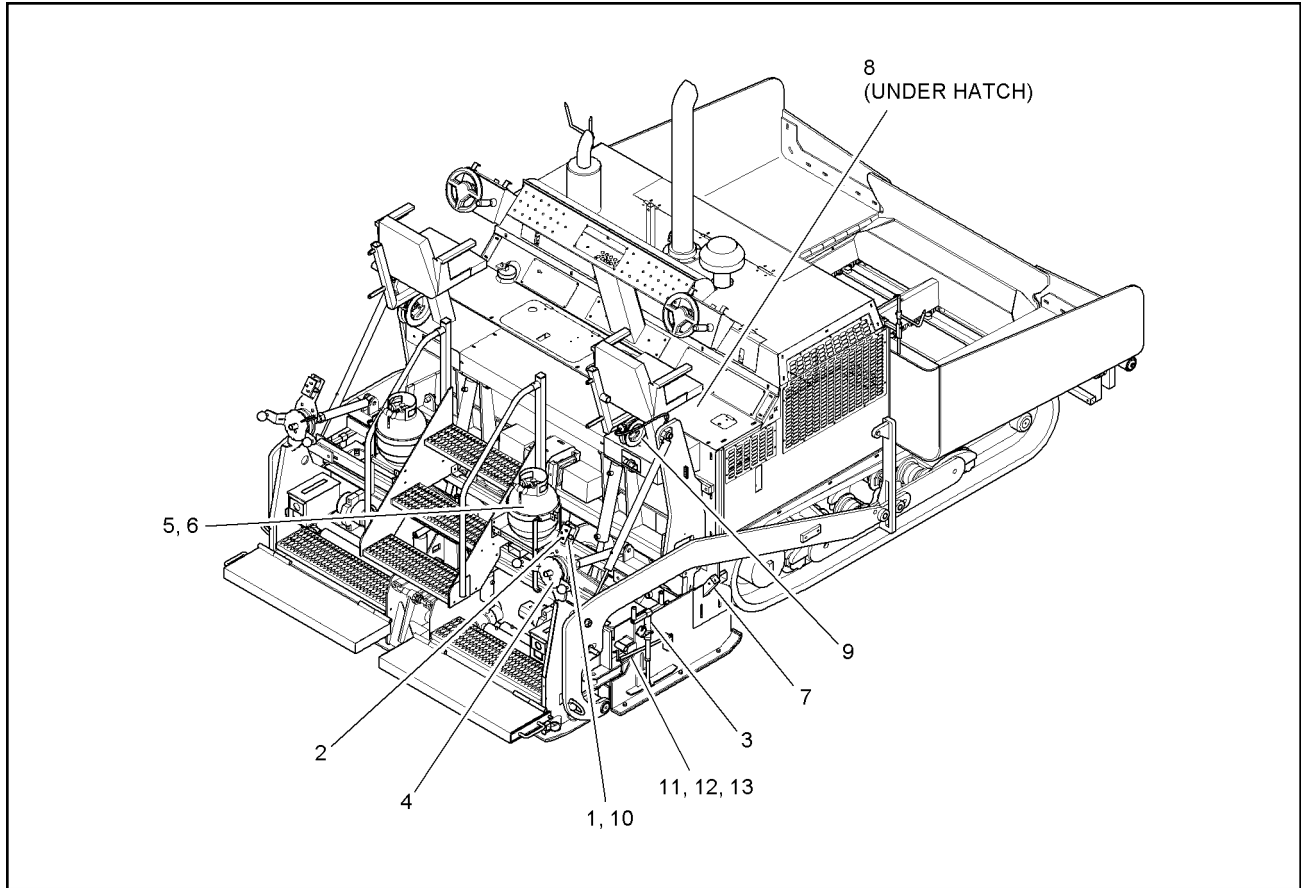

FIGURE 3-4. RIGHT SIDE CONTROLS

TABLE 3-1. OPERATING CONTROLS, INDICATORS, AND GAUGES (CONTINUED)

FIG. REF	ITEM NO.	CONTROL NAME	TYPE	FUNCTION
3-4	1	Sonic Auger Adjustment		Adjusts the height of material at End Gate Sensor (item 7) mounted on End Gate. Controls AUGER SPEED in manual.
3-4	2	Right Auger Box		Contains toggle switches for RIGHT EXTENSION IN/OUT, SLOPE RAISE/LOWER, LEFT AUGER ON/OFF, and AUGER MATERIAL HEIGHT MIN/MAX, MANUAL AUGER SPEED. NOTE: Auger toggle should be left in ON position at all times. Auger and screed extensions can be operated by a person standing on Lower walkway. Left Auger box is identical and located on left side of the machine.

Section 3 OPERATION



TABLE 3-1. OPERATING CONTROLS, INDICATORS, AND GAUGES (CONTINUED)

FIG. REF	ITEM NO.	CONTROL NAME	TYPE	FUNCTION
3-4	3	Depth Screw		This control sets the depth of the End Gate.
3-4	4	Flight Screw		This lever controls the depth of the asphalt.
3-4	5	Propane Tank Pressure Regulator		Regulates propane pressure. NOTE: Pressure should be 15 lbs.
3-4	6	Propane Tank Main Valve		Opens and closes propane tank pressure.
3-4	7	Sonic Auger Sensor		Used for adjusting the height of material at End Gate. Connected to Sonic Auger Adjustment (Item 1). (Keep End clean)
3-4	8	Conveyor Drive Chain Adjustment		Screws with jam nuts for adjusting the conveyor chain tension.
3-4	9	Spray Down Hose		Used to lubricate and keep asphalt from hardening on the machine.
3-4	10	Speed and Pile Height	Potentiometer	Adjust thickness of material.
3-4	11	Tilt Screw		Used to adjust the tilt on End Gate.
3-4	12	Adjustment Screw Vertical Height Not Shown		Adjusts the front of the extension to provide the best mat. Up or down and can level extension at wide widths.
3-4	13	Adjustment Screw Matt Texture Rougher or Smoother Not Shown		Adjusts the other end of the front of the extension. Tilt Rougher or Smoother.

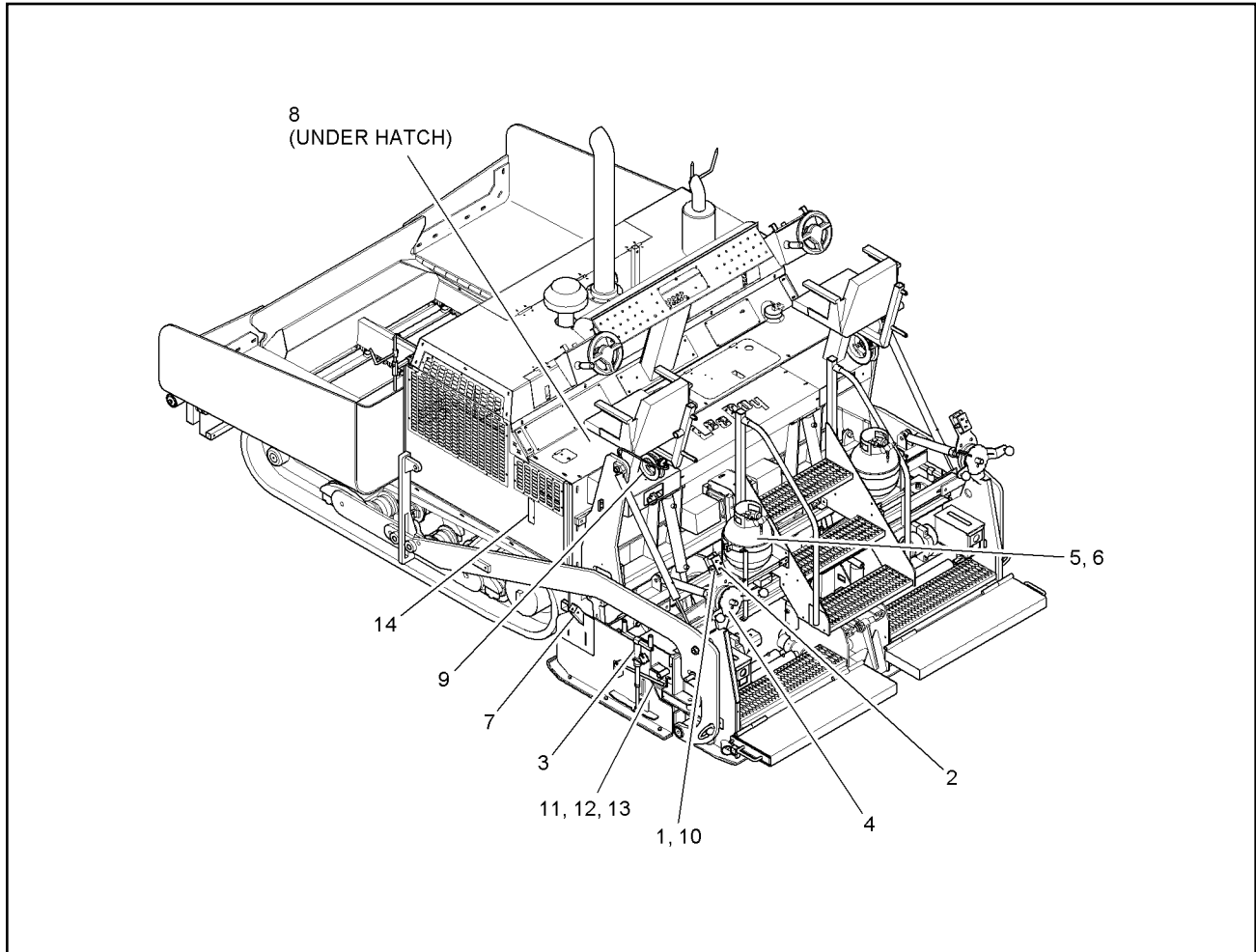

FIGURE 3-5. LEFT SIDE CONTROLS

TABLE 3-1. OPERATING CONTROLS, INDICATORS, AND GAUGES (CONTINUED)

FIG. REF	ITEM NO.	CONTROL NAME	TYPE	FUNCTION
3-5	1	Sonic Auger Adjustment Left		Adjusts the height of material at End Gate Sensor (Item 7) mounted on End Gate. Controls AUGER SPEED in manual.
3-5	2	Left Auger Box		Contains toggle switches for LEFT EXTENSION IN/OUT, SLOPE RAISE/LOWER, LEFT AUGER ON/OFF, and AUGER MATERIAL HEIGHT MIN/MAX, MANUAL AUGER SPEED. NOTE: Auger toggle should be left in ON position at all times. Auger and screed extensions can be operated by a person standing on Lower walkway. Right Auger box is identical and located on right side of the machine.

Section 3 OPERATION



TABLE 3-1. OPERATING CONTROLS, INDICATORS, AND GAUGES (CONTINUED)

FIG. REF	ITEM NO.	CONTROL NAME	TYPE	FUNCTION
3-5	3	Depth Screw		This control sets the depth of the End Gate.
3-5	4	Flight Screw		This lever controls the depth of the asphalt.
3-5	5	Propane Tank Pressure Regulator		Regulates propane pressure. NOTE: Pressure should be 15 lbs.
3-5	6	Propane Tank Main Valve		Opens and closes propane tank pressure.
3-5	7	Sonic Auger Sensor		Used for adjusting the height of material at End Gate. Connected to Sonic Auger Adjustment (Item 1). Keep End Clean.
3-5	8	Conveyor Drive Chain Adjustment		Screws with jam nuts for adjusting the conveyor drive chain tension.
3-5	9	Spray Down Hose		Used to lubricate and keep asphalt from hardening on the machine.
3-5	10	Speed and Pile Height	Potentiometer	Adjust thickness of material in End Gate.
3-5	11	Tilt Screw		Used to adjust the tilt on End Gate.
3-5	12	Adjustment Screw		Adjusts the front of the extension to provide the best mat. Up or down and can level extension at wide widths.
3-5	13	Adjustment Screw		Adjusts the other end of the front of the extension. Tilt Rougher/Smother.
3-5	14	Temperature Gauge		Monitors the temperature of the hydraulic fluid.
3-5	14	Hydraulic Oil Level/ Temperature Check Point		Used to check oil level in hydraulic oil tank.

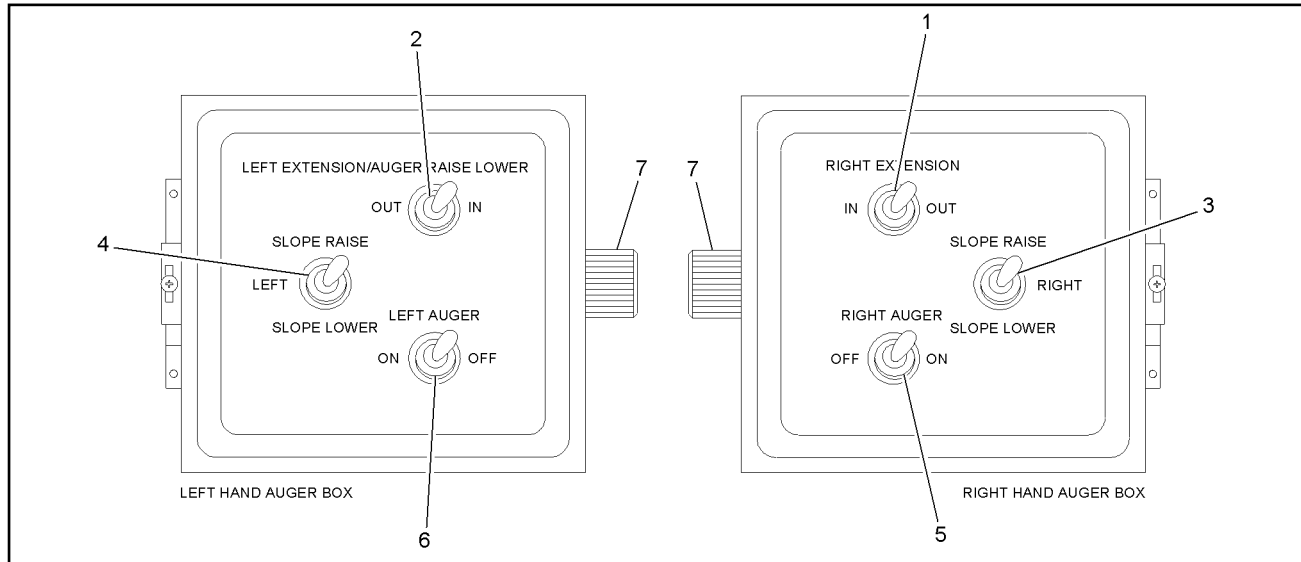

FIGURE 3-6. LEFT AND RIGHT AUGER BOXES

TABLE 3-1. OPERATING CONTROLS, INDICATORS, AND GAUGES (CONTINUED)

FIG. REF	ITEM NO.	CONTROL NAME	TYPE	FUNCTION
3-6	1	RIGHT EXTENSION IN/OUT	3-position toggle switch	IN position moves extension in. OUT position moves extension out. Center position stops movement.
3-6	2	LEFT EXTENSION/AUGER RAISE LOWER IN/OUT	3-position toggle switch	IN position moves extension in. OUT position moves extension out. Center position stops movement. Also used to Raise & Lower Augers for loading. (Must select extension or auger Raise & Lower at selector.)
3-6	3	RIGHT SLOPE RAISE and LOWER	3-position toggle switch	Up position raises slope. Down position lowers slope. Center position stops movement.
3-6	4	LEFT SLOPE RAISE and LOWER	3-position toggle switch	Up position raises slope. Down position lowers slope. Center position stops movement.
3-6	5	RIGHT AUGER OFF/ON	2-position toggle switch	Turns the right auger on or off. Leave on.
3-6	6	LEFT AUGER OFF/ON	2-position toggle switch	Turns the left auger on or off.
3-6	7	AUGER MATERIAL HEIGHT - MANUAL AUGER SPEED	Rotary control	When the LEFT CONVEYOR AND AUGER (7, Figure 3-2) and RIGHT CONVEYOR AND AUGER (8, Figure 3-2) are in AUTOMATIC position, this control controls the amount of material in extension. In MANUAL position, controls the speed of augers. NOTE: The augers will not run at "0" position.

Section 3 OPERATION



OPERATION

SAFETY

Operating Safety

Always make sure no person or object is in the line of travel before starting.

Work slowly in tight areas.

Do not run engine in a closed building for long periods of time. Never spray cleaning solvent on or near screed while it is being heated.

Avoid steep hills if possible.

Always look before changing the direction of travel.

Never open a valve to burner unless a flame is present. Do not heat screed for more than 15 minutes. Make sure all valves are closed before propane is turned off.

Avoid leaving engine running without operator present.

Stopping Safety

Always park the Paver on solid, level ground in low range. If this is not possible, always park the paver at a right angle to the slope. Lower screed when parked.

Use proper flags, barriers and warning devices, especially when parking in areas of traffic.

Maintenance Safety

Never work on the paver with the engine running.

Never fill the fuel tank with the engine running.

Do not change the engine governor settings.

Always replace damaged or lost decals.

Disconnect battery cables using the DISCONNECT switch when working on the electrical system or when welding on the unit.

If battery needs a charge, be sure battery charger is off when making connections.

Be sure the correct battery polarity is observed (negative (-) to negative (-) and positive (+) to positive (+)) when connecting a battery charger or jumper cable.

Work slowly in tight areas.

Do not run engine in a closed building for long periods of time.

Never spray cleaning solvent or release agent on or near screed while it is being heated.

PRE-START INSPECTION

Inspect machine. Have any malfunctioning, broken or missing parts corrected or replaced before using. Hydraulic hoses should be checked daily for wear and leaks. Replace if damaged.

Check that all the instruction and safety labels are in place and readable. These are as important as any other equipment on the machine.

Read and Follow all instruction decals.

Wear OSHA required safety equipment when running the paver.

Fill the fuel tank with the engine off. Never fill fuel tank near an open flame, when smoking, or when screed heat is on. (Fill at end of day to keep condensation out.)

Before starting engine, clear auger & feeders. Make sure all covers and guards are in place.

STARTING THE ENGINE

Preliminary

Before starting the engine:

1. Check fuel level.
2. Check fuel lines, and tank for leaks.
3. Check crankcase oil level.

CAUTION: Failure to maintain correct engine oil level is the greatest single cause of engine failures.



4. Check hydraulic oil level. Oil level is determined by sight gauge on the hydraulic tank on the left side of unit. (AW #68 Hydraulic Oil)
5. Make sure joystick (Figure 3-7, Item 1) is in neutral position.
6. Refer to engine operator's manual for instructions when starting engine for the first time. Follow engine manufacturer's recommendations for fuel and oil.

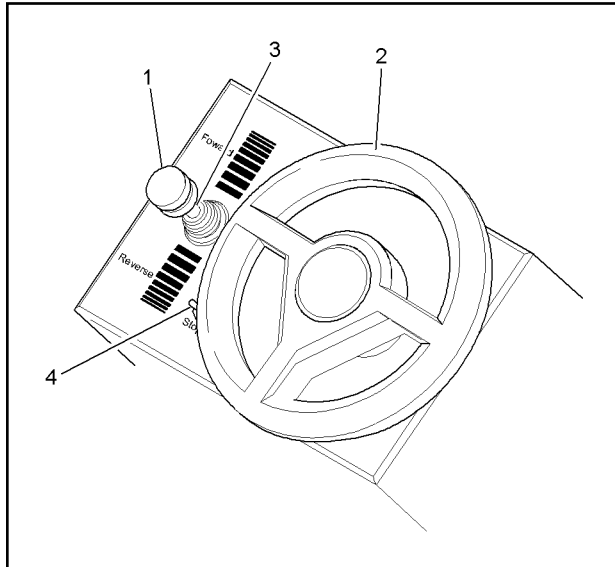



FIGURE 3-7. SPEED AND STEERING CONTROL BOX

Engine Start-Up

NOTE: Joystick (Figure 3-7, Item 1) must be in neutral position to start engine.

1. Position joystick to neutral.
2. Throttle at Idle or 1/2 by pressing and holding THROTTLE switch in the up or down position.

CAUTION:  The use of starting additives, such as ether, is not recommended if equipped with Intake Heaters.

CAUTION:  Do not operate the starter longer than 10-15 seconds. If the engine does not start, allow the starter to cool 2-3 minutes.

3. Insert key into the ignition switch on instrument panel and turn key clockwise (CW) to start position.
4. When engine starts and is running smooth, throttle back to idle by pressing and holding either THROTTLE switch on the dash panel in the down position until idle speed is reached. Never work both switches at one time.

NOTE: Allow engine to warm up for several minutes before moving paver. The warm up will give the hydraulic oil time to warm, providing for more efficient operation. In cold weather let hydraulic oil warm to 50°F (10°C) or 60°F (16°C) before moving.

NOTE: For convenience, there is an extra key inside the switch box in case the original key is lost.

Stopping the Engine

1. Throttle back to idle by pressing and holding either THROTTLE switch in the down position until idle speed is reached.
2. Turn ignition key on instrument panel counter-clockwise (CCW) to the OFF position and remove key.

PAVER DRIVING INSTRUCTIONS

General

The Electronic Control Steering Box

To drive the machine, check that the steering wheel (Figure 3-7, Item 2) is centered so the machine will go straight ahead. Lift up on the neutral latch (3) on joystick (1). Push the joystick (lever) forward slowly to reach the desired speed and turn the steering wheel (2) slowly to make turns as desired. The more you move the joystick the faster the travel speed.

NOTE: To stop machine, pull joystick back to the neutral position.

1. After the paver has been started and the engine is warmed up, paver movements may be made.
2. To drive machine forward lift up on the neutral lock (3) on joystick (1) and push joystick forward to reach desired speed. To move in reverse pull the joystick backward to reach desired speed. Place joystick in neutral to stop machine.

NOTE: To slow the unit, move joystick closer to neutral or in neutral to stop.

3. To steer the unit, turn the steering wheel (2) in the travel direction desired. The further the wheel is turned, the more the machine turns. Slow and easy adjustments are required.

CAUTION:  Turning the wheel too far Left or Right will make machine Counter Rotate.

4. The RUN/STOP toggle switch (4) on steering box will stop machine when set to the STOP position. When the machine is stopped with the toggle switch, the machine will resume travel at the last speed of travel when the switch is set to the RUN position.

Section 3 OPERATION



PAVER PREPARATION INSTRUCTIONS

Burner Ignition Procedures

General

WARNING: Propane gas used to heat the screed is volatile and combustible. Use extreme care and follow the instructions.



The heating of the screed requires extreme care. The propane gas used to heat the screed is volatile and combustible. When treated with respect the propane will not present a problem. Follow the procedures below and refer to Figure 3-8 as required.

1. Check that all burner valves are turned off (see Figure 3-9).

CAUTION: Never open a valve to a burner unless flame is present. A buildup of unburned gas could result in a gas explosion.



2. Use ignitor burner to light main burners manually. Hold ignitor burner at end of main burner and turn valve on. Repeat this procedure for opposite side.

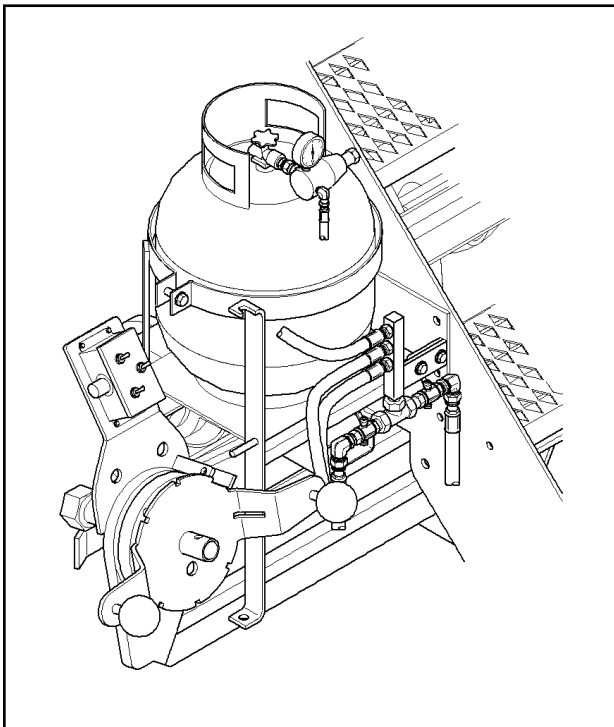

FIGURE 3-8. PROPANE TANK WITH REGULATOR

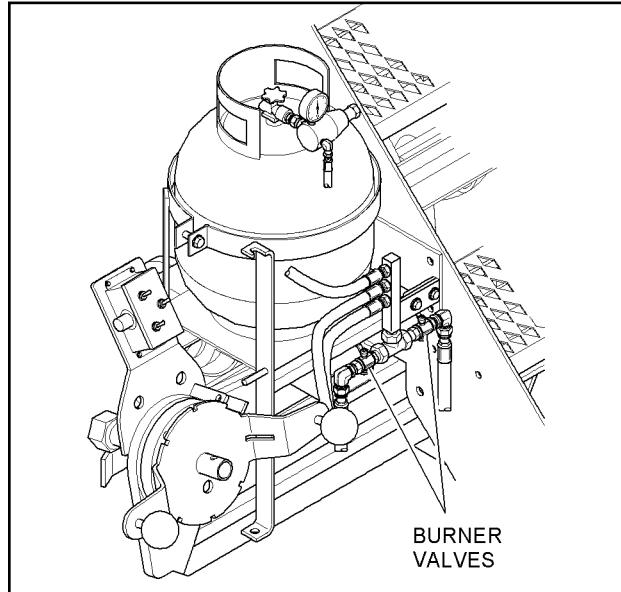

FIGURE 3-9. BURNER VALVES

3. Extension burners are lit manually by Left or Right ignitor as main burners. Turn "on" valve for extension burner and use lighter to light.

NOTE: You do not have to disconnect to light. (see Figure 3-10).

4. After screed has heated for about 15 minutes, turn the burners off by rotating the burner valves to the "off" position.

NOTE: Heating the screed helps prevent hot mix from sticking to the cold screed plate and produces a smooth, tight mat surface. Heating should not only be performed at the beginning of the job, but also if the machine is idle for a long time between loads (allowing screed plate to cool).

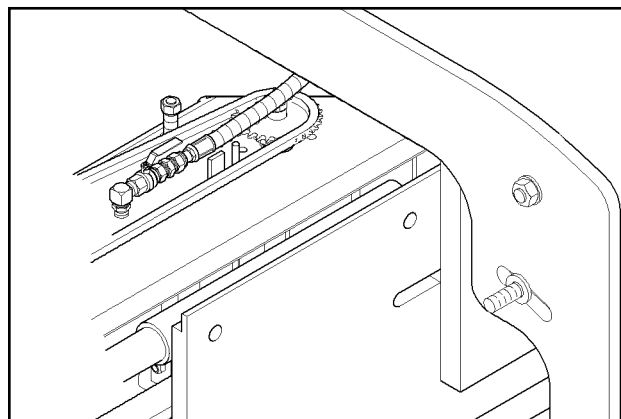

FIGURE 3-10. EXTENSION BURNER ON AND OFF VALVE CONNECTOR

NOTE: If paving on a cool windy day, it may be necessary to maintain low heat on the screed. To accomplish this, reduce the pressure on the propane tank from 15 lbs. (1 bar) to 6 lbs. (0.41 bar). This will provide a low even heat that will not harm the screed. Do not attempt to regulate the burner with the burner valve.

CAUTION: Too much heat for too long can warp screed plate and cause mat texture problems. A warped screed plate should be replaced.



TRUCK HITCH ATTACHMENT (OPTIONAL)

GENERAL

The truck hitch is an optional attachment. It was designed to improve the asphalt laying process. This is mainly accomplished by keeping the truck driver off his brakes, preventing excessive and uneven braking. To engage the hitch with the rear wheels of the asphalt truck, proceed as follows:

1. Extend the arm extensions of the truck hitch by setting the TRUCK HITCH switch to the OUT position to extend the hitch arms.

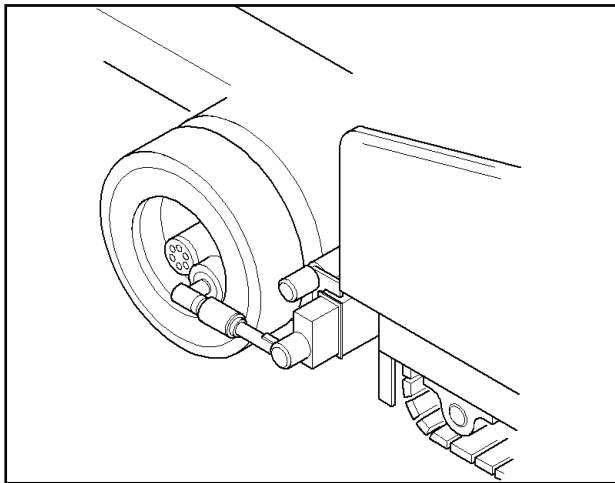

FIGURE 3-11. TRUCK HITCH

2. Slowly back rear of truck until roll on hitch makes contact with the rear tires of the truck
3. Retract the arm extension by setting the TRUCK HITCH switch to the IN position to retract the hitch arms until both guide rollers are fully locked into truck wheel rims.
4. It may be necessary to adjust the roller guides to the inside of the wheel rims, initially.

OPERATING FEEDER

GENERAL

The feeder (conveyor) is a very important part of the paver and for this reason close attention should be given on integrating its operation into the total operation of the paver. Use the following procedure for operating the feeder.

1. Spray the feeder drive chains periodically. Spray several times a day with cleaning solvent or release agent.
2. Irregular movement of the feeder conveyor indicates that a problem may exist with the feeder chain. To eliminate this problem an adjustment to the feeder chain may be necessary. Refer to the paragraph CONVEYOR FLIGHT CHAIN ADJUSTMENT procedure in Chapter 4.

CAUTION: Never work on conveyors with engine running.



CAUTION: Never let paver sit with conveyors turning. Turn OFF when not using.



CAUTION: To prevent flight chains from sticking, lubricate them sufficiently at the end of the day.



Section 3 OPERATION



OPERATING TOW POINT CYLINDERS

GENERAL

The Tow Point Cylinders are an added convenience to the operator. A gauge is located on both sides of the paver. These gauges will provide the operator with quick reference to the height of the screed. Refer to Figure 3-12 and use the following procedures:

1. Before paving, center the Tow Point by referring to the screed elevation gauge on each side of the paver. Raise or lower until rod end is flush with 0 on Decal.
2. While paving, refer to both gauges and make minor adjustment to the screed by using the Tow Point adjustment.

NOTE: Mostly used with Automatic Grade Controls. All 8816's are pre-wired for Grade Controls.

NOTE: For Tow Point Screws to work both side Grade Switches on dash must be on and joystick forward with engine running.

NOTE: Never let End Gates carry the weight of screed.

OPERATING HYDRAULIC CUTOFF GATES

GENERAL

The cutoff gates are one of the most important functions of the paver, when used properly. Cutoffs are used primarily to control the flow of asphalt to the screed. Cutoffs can be used when making passes, at the beginning and ending of each pass or pull.

NOTE: The RIGHT CUTOFF OPEN/CLOSE switch and the LEFT CUTOFF OPEN/CLOSE switch control the right and left cutoffs.

1. Moving the switches to the OPEN positions increases asphalt flow to the screed. Moving the switches to the CLOSE positions decreases asphalt flow to the screed.

NOTE: Always work cutoff switches one at a time when opening or closing. If both switches are worked together, normally one will open or close before the other.

NOTE: When loading machine, running over curbs, or manholes, always make sure cutoffs are all the way open. When loading be sure that augers are in the raised position or cutoff may be damaged (see Figure 3-13).

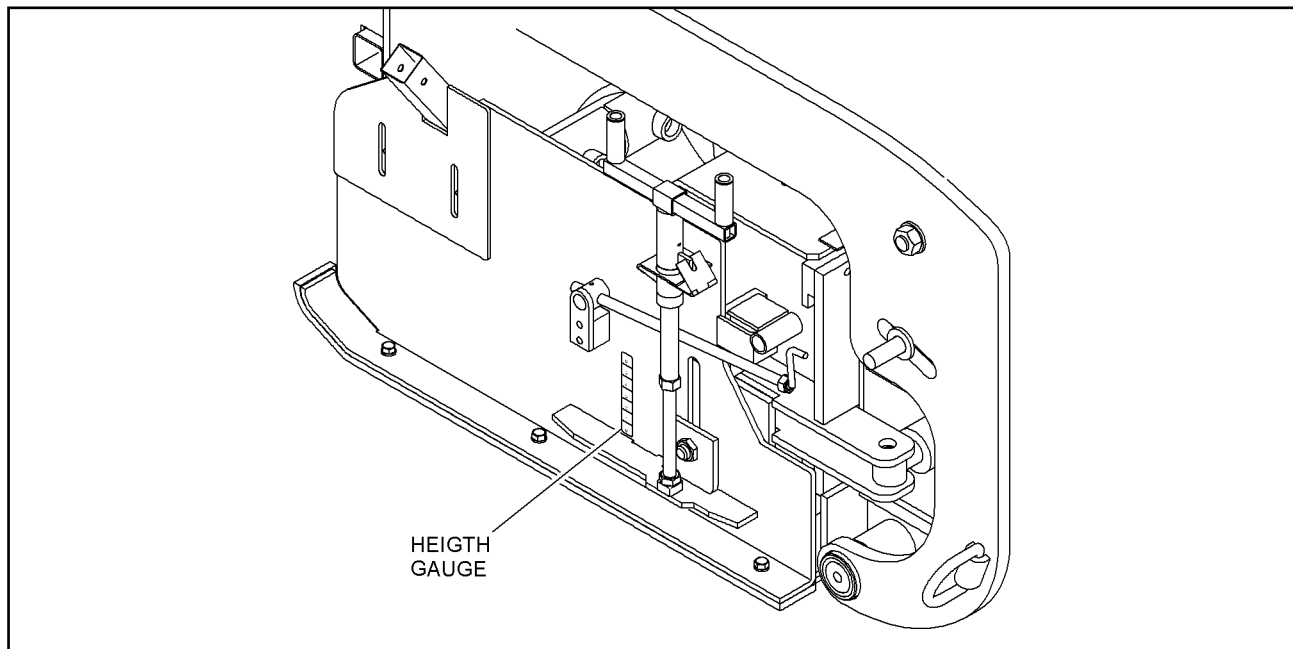

FIGURE 3-12. DEPTH SCREWS AND SCREED HEIGHT GAUGES

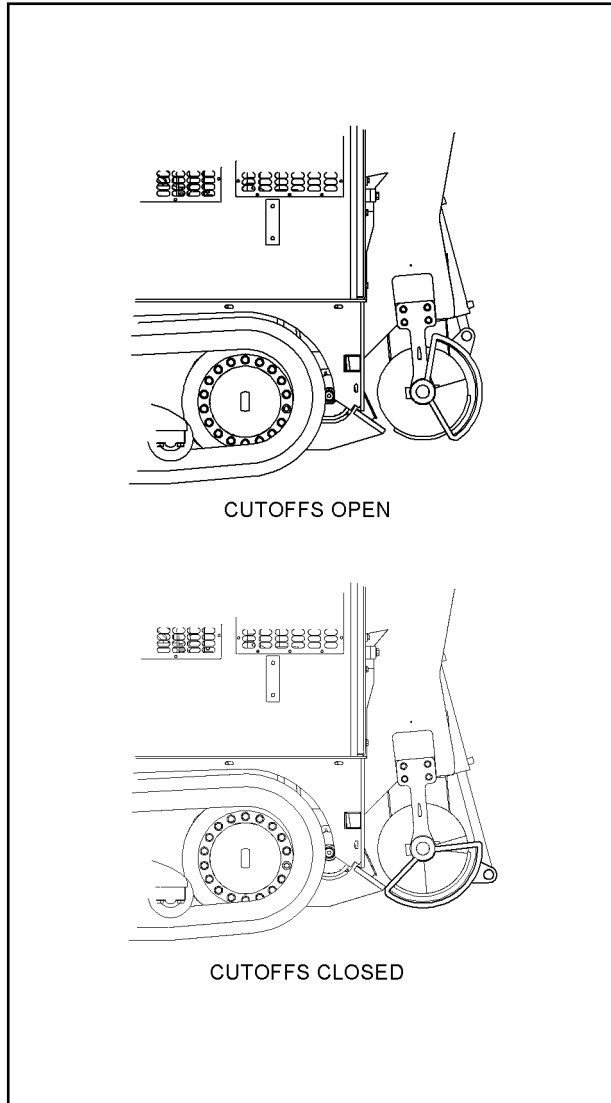

FIGURE 3-13. CUTOFFS OPEN AND CLOSED

ELECTRIC SPRAY DOWN

GENERAL

The spray down on your machine (see Figure 3-14) is used to spray cleaning solvent on any part of the machine that comes in contact with the asphalt. Build-up of asphalt will cause damage to components. Spray all areas of machine that have direct contact with asphalt.

NOTE: When using spray down consider the environment and do not allow cleaning solvent to run onto the ground.

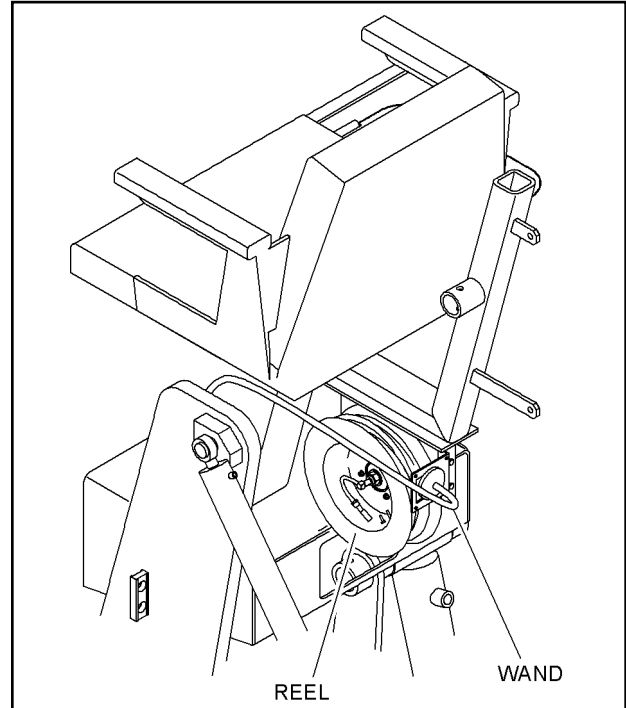

FIGURE 3-14. SPRAY DOWN HOSE AND WAND

CAUTION: Never use spray down when burners are lit.



1. Unroll the amount of hose needed and set SPRAY DOWN switch to SPRAY DOWN (up) position. Squeeze the wand handle and spray. Release wand handle when done spraying.
2. After spraying set SPRAY DOWN switch to the OFF (down) position and rewind hose.

AUGERS

SONIC AUGERS

General

The sonic augers are most often used when paving 10 ft. or wider where augers are capable of running material over top of endgates, causing extra handwork.

The sonic auger gauges the amount of material that is in the extensions. To operate the sonic augers the LEFT AUGER AND RIGHT AUGER toggle switches on the left side dash must be set to the AUTOMATIC position and the LEFT AUGER and RIGHT AUGER toggle switches on the right side dash must be set to the SLAVE position. In addition the LEFT AUGER switch and the RIGHT

Section 3 OPERATION



AUGER switch, located on the Remote Screenshot boxes, must be set to the ON position. The sonic will turn the auger OFF and ON, automatically. To override the automatics, the LEFT AUGER and RIGHT AUGER toggle switches must be set to MANUAL and the augers controlled manually from the dash or from screenshot using OFF on switch or potentiometer.

Operating from Left Operators Seat

NOTE: An operator can operate the Auger and Conveyor from either side.

CAUTION: To prevent damage, point sensor cord toward front of machine.



1. Attach Auger sensors to the endgates and plug cords in tight.
2. Set the LEFT AUGER switch and the RIGHT AUGER switch, located on the Remote Screenshot boxes, to the ON position (see Figures 3-15 and 3-16).
3. Set the LEFT AUGER AND RIGHT AUGER toggle switches on the left side dash to the AUTOMATIC position.
4. Set the LEFT AUGER AND RIGHT AUGER toggle switches on the right side dash to the SLAVE position. (Right side does not need to be turned off when operating from the left side unless for safety purposes.)

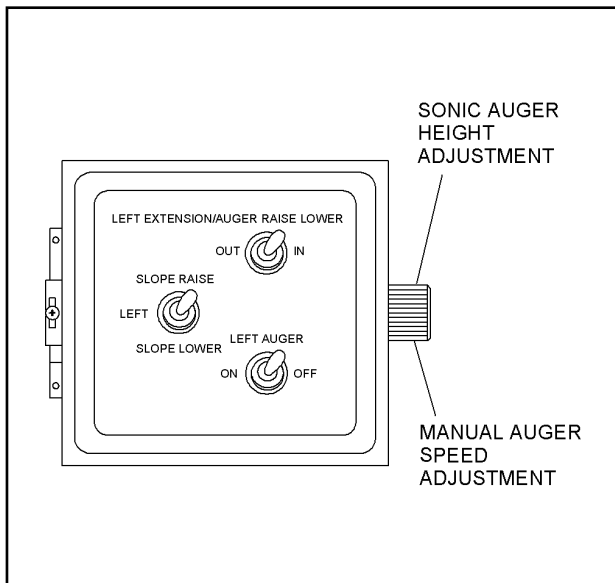

FIGURE 3-15. LEFT SIDE SONIC AUGER HEIGHT ADJUSTMENT

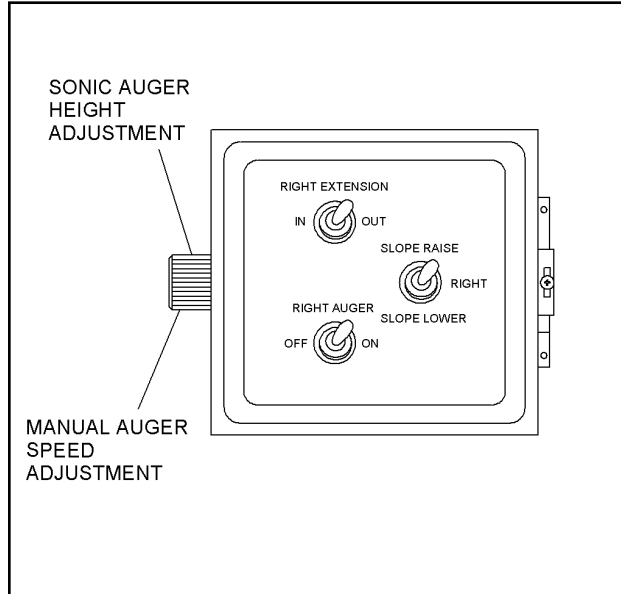

FIGURE 3-16. RIGHT SIDE SONIC AUGER HEIGHT ADJUSTMENT

NOTE: The sonic auger adjustment dial adjusts the amount of material needed or selects in manual auger speed.

5. Adjust height of material at endgate with the sonic auger adjustment (see Figures 3-15 and 3-16). Turn the dial to the 2:00 clock position, once material is to the endgate. Use the knob to adjust material height. Keep the extension full. Be careful not to over run the extension with the material or material will spill around front of Endgate.

CAUTION: If augers do not turn and conveyors do, ensure both left and right AUGER BYPASS switches are in center position.



NOTE: When running material through augers manually, try to pave so material flow to extension is adequate and maintained. Potentiometer on Remote Screenshot Box controls auger speed in manual.

6. When paver stops, set the LEFT AUGER AND RIGHT AUGER SWITCHES on either side of dash to the "Off" (center) position or at Remote Screenshot Boxes.

Operating from Right Operators Seat

NOTE: An operator can operate the Auger and conveyor from either side.

CAUTION: To prevent damage, point sensor cord toward front of machine.



1. Attach Auger sensors to the endgates and plug cords in tight.
2. Set the LEFT AUGER switch and the RIGHT AUGER switch, located on the Remote Screed boxes, to the ON position (see Figure 3-15 AND 3-16).
3. Set both the LEFT CONVEYOR AND AUGER and the RIGHT CONVEYOR AND AUGER toggle switches on the left side dash to the AUTOMATIC position. (Left side does not need to be turned off when operating from the right side unless for safety purposes.)
4. Set the LEFT AUGER and RIGHT AUGER toggle switches on the right side dash to the SLAVE position.

NOTE: The sonic auger adjustment dial adjusts the amount of material needed or selects in manual auger speed.

5. Adjust height of material at endgate with the sonic auger adjustment (see Figures 3-15 and 3-16). Turn the dial to the 2:00 clock position, once material is to the endgate. Use the knob to adjust material height. Keep the extension full. Be careful not to over run the extension with the material or material will spill around front of Endgate.

CAUTION: If augers do not turn and conveyors do, ensure both left and right AUGER BYPASS switches are in center position.



NOTE: When running material through augers manually, try to pave so material flow to extension is adequate and maintained.

6. When paver stops, set the LEFT AUGER and RIGHT AUGER SWITCHES on the dash to the "Off" (center) position. To prevent hydraulic oil from overheating while waiting on material or hand work, turn conveyor and augers OFF.

Manual Operation

NOTE: An operator can operate the Auger and conveyor from either side.

1. Set the LEFT AUGER switch and the RIGHT AUGER switch, located on the sonic auger boxes, to the ON position (see Figure 3-15 AND 3-16).
2. Set both the LEFT CONVEYOR AND AUGER and the RIGHT CONVEYOR AND AUGER toggle switches on the left side dash to the MANUAL position.
3. Set the LEFT AUGER and RIGHT AUGER toggle switches on the right side dash to the SLAVE position.

NOTE: The sonic auger adjustment dial adjusts the amount of material needed in AUTO position. In MANUAL position the dial controls the speed of conveyor and auger.

CAUTION: If augers do not turn and conveyors do, ensure both left and right AUGER BYPASS switches are in center position.



NOTE: When running material through augers manually, try to pave so material flow to extension is adequate and maintained. Potentiometer on Remote Screed Box controls auger speed in manual.

4. When paver stops, set the LEFT AUGER and RIGHT AUGER switches on either side of dash to the "Off" (center) position or at Remote Screed Boxes.

NOTE: For your convenience there is a Decal located on each Compartment Door of Hood explaining Conveyor Operation in English and Spanish.

Section 3 OPERATION



Raising and Lowering Augers

The augers can be raised or lowered using the manual valve,(see Figure 3-17). This valve is located under the seat on the left side of the machine. When raising or lowering the Augers, this valve must be set to the AUGER RAISE AND LOWER position, then the left Extension toggle will raise or lower the Auger Assembly.

NOTE: To prevent damage when loading or unloading the machine cutouts must be in the open position and Augers raised.

Auger/Conveyor and Drive Micros

The Right Auger/Conveyor micros are shown in Figure 3-18 and the Left Auger micros and Drive micros are shown in Figure 3-19.

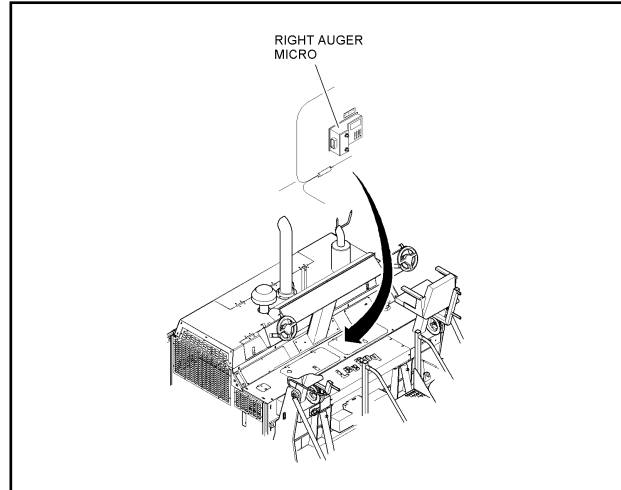

FIGURE 3-18. RIGHT AUGER MICROS

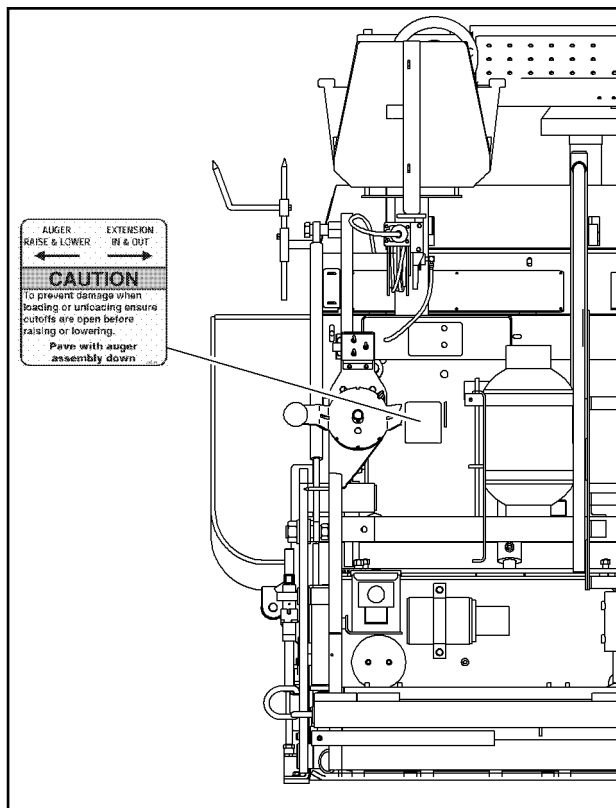

FIGURE 3-17. MANUAL RAISE/LOWER VALVE

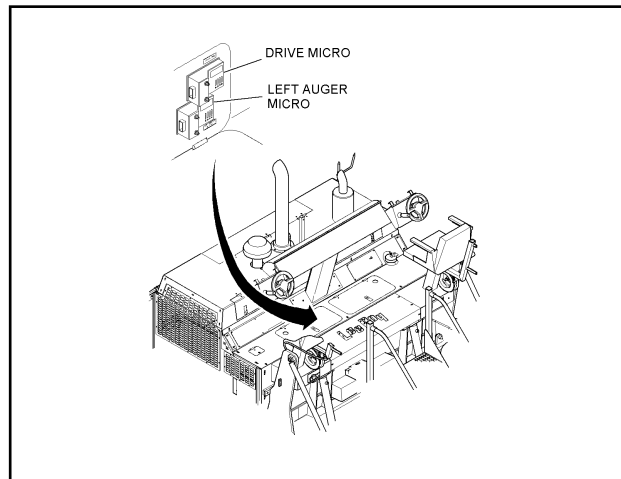

FIGURE 3-19. LEFT AUGER MICROS AND DRIVE MICROS

LOADING AND UNLOADING

GENERAL

Trailers used to haul the paver should have ample capacity to carry the weight of the paver. Place the trailer in a clear, level area for loading or unloading.

WARNING: Work slowly and carefully to avoid accidents. Keep the area clear.



UNLOADING

1. Remove tie down equipment.
2. Start and warm up engine.
3. Set throttle at 1/2 operating RPM. Set steering control lever so paver moves very slowly.
4. Make sure:
 - a. Screed position - UP
 - b. Extendible screed - IN
 - c. Gates below augers - Make sure they are open and augers raised

NOTE: A person should always be on the ground to assist the operator in the unloading procedure.

WARNING: Make sure engine is operating at a high enough RPM so that the hydraulic pump is providing sufficient flow to operate all functions properly.



CAUTION: Do not let the screed, auger, or cutoffs strike the ramp when moving off the ramp. This can cause damage to bearings on the thickness control screws, welds on the leveling arms, auger damage, and cutoff damage.



CAUTION: Be sure auger and cutoffs are in raised position. (see Figure 3-13)



NOTE: If you have a problem unloading the paver - STOP - LOOK - THINK.

5. Move paver forward down the ramp as shown in Figure 3-20.

LOADING

CAUTION: Paver must be loaded screed end first to prevent damage. (see Figure 3-21)



1. Move paver to base of ramp. Line up tracks with the ramp.
2. Make sure of the following:
 - a. Screed position is - UP
 - b. Extendible screed - IN
 - c. Gates below auger - Make sure they are open and augers raised

NOTE: Always have a helper on the ground that can assist the operator in moving the paver onto the transport.

CAUTION: To prevent an excessive jolt to the undercarriage and throughout the paver, reduce traveling speeds to a minimum before the paver tracks come in contact with loading ramps or an abrupt change in the surface. If encountered, the track drive sprocket or possible other components may be damaged because of the excessive jolt.



3. Load paver screed end first. Set throttle at 1/2 operating RPM and steering control lever so paver moves very slowly onto the ramp.
4. With the steering control lever slowly guide the paver up the ramp.
5. Place paver in center of trailer or desired position.
6. Lower screed to deck.
7. Shut down engine.
8. Secure paver to transport as directed by regulations.

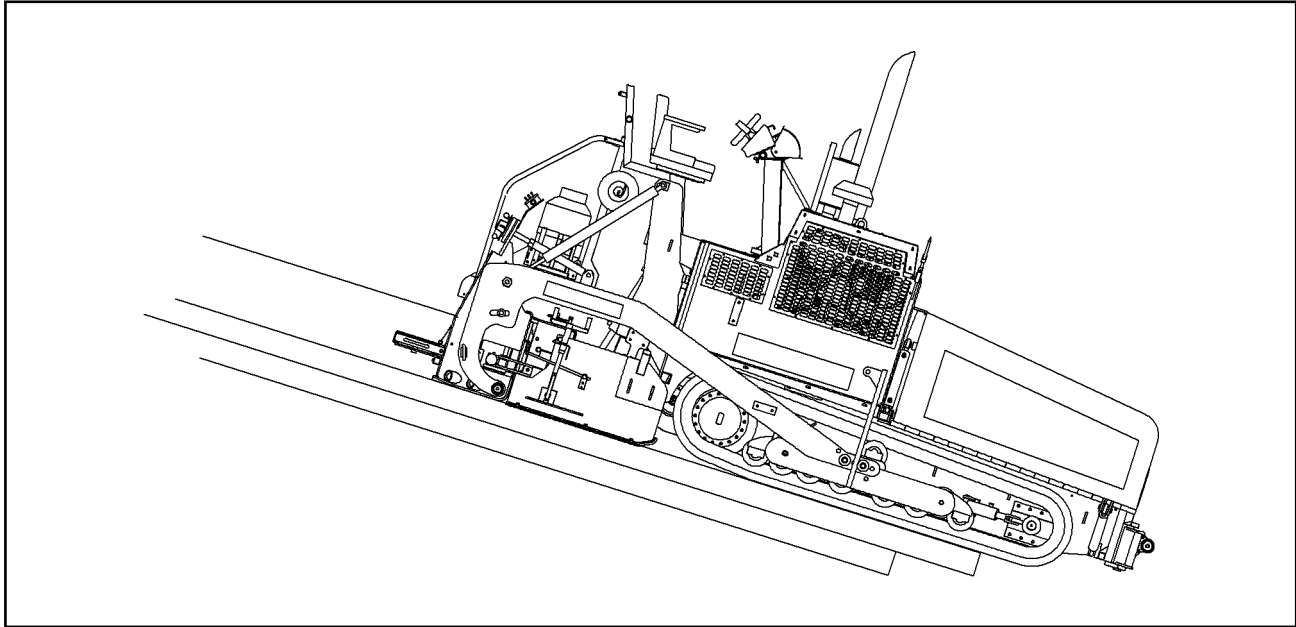

FIGURE 3-20. UNLOADING AND LOADING

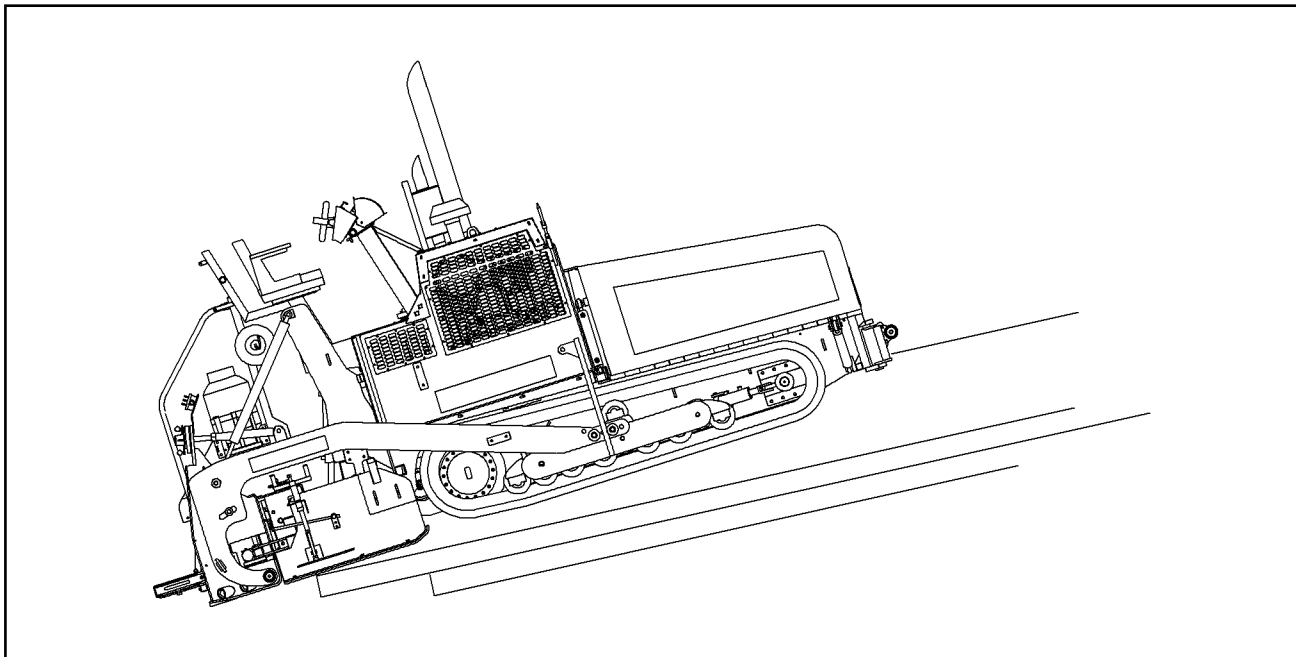

FIGURE 3-21. INCORRECT LOADING POSITION

TIE DOWN PROCEDURE

1. Position paver on trailer centered from side to side (see Figure 3-22).
2. Attach tie down chain to the hopper end of paver at the D-rings (see Figure 3-23).
3. Attach tie down chain to the screed end of paver at the D-rings.
4. Place chocks at wheels or tracks.
5. Make sure all chains are tight before moving.

PAVING PREPARATION INSTRUCTIONS

To prevent costly down time, the paver should be checked thoroughly before each use. Use the list below to assist in checking out the paver.

1. Check engine oil (see engine manual), hydraulic oil, torque hub oil and diesel fuel.
2. Refer to Lubrication Chart in Section 4 - MAINTENANCE and lubricate as specified. (Some area or weather conditions may require extra lubrication).

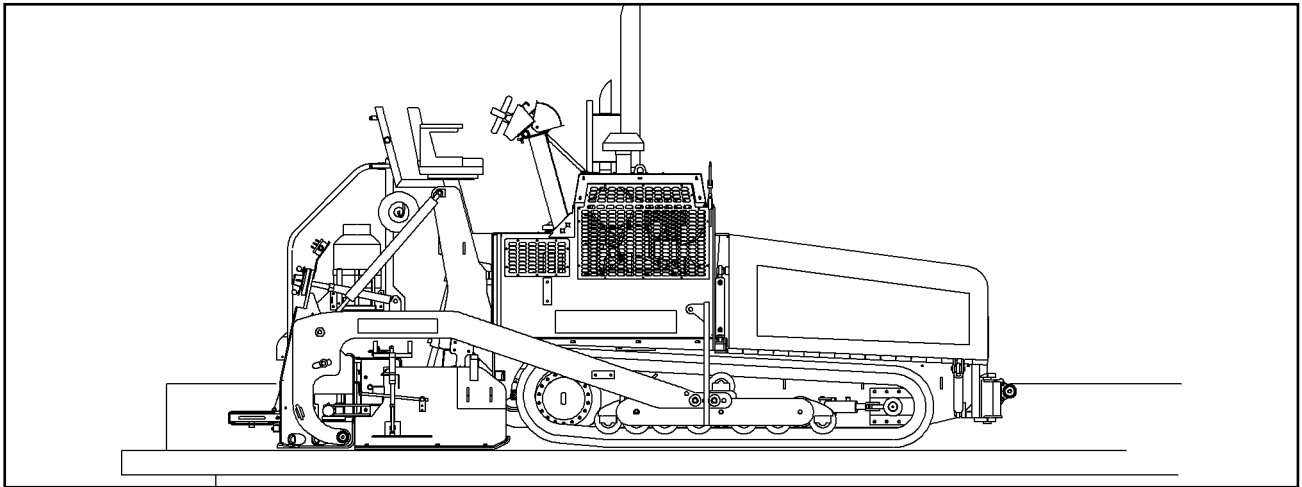

FIGURE 3-22. PAVER ON TRANSPORT

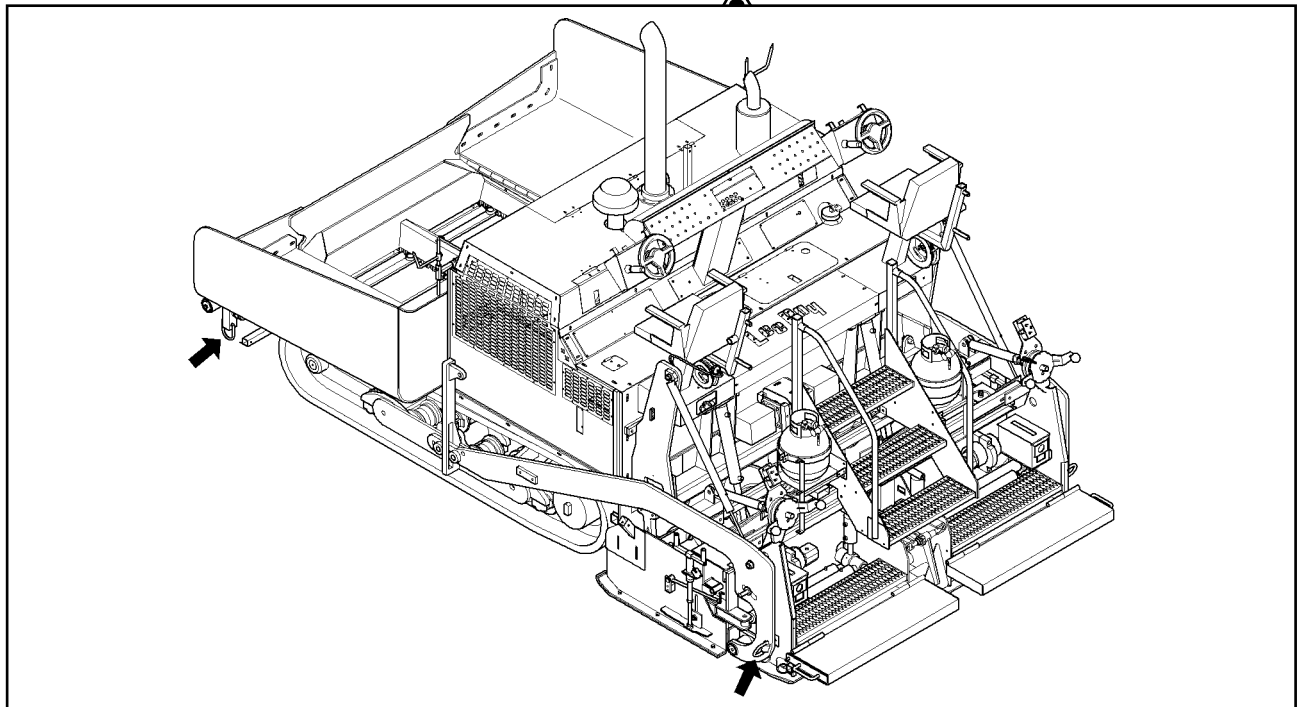

FIGURE 3-23. TIE DOWN POINTS

Section 3 OPERATION



3. Check hydraulic hoses, fittings, pumps, and motors for leaks, excessive wear, or damage.
4. Check the engine safety switch (the engine should only start when the joystick forward/reverse lever is in the neutral position) (see Figure 3-3).
5. Check all electrical functions before distributing asphalt.
6. Spray cleaning solvent on any part of the paver that comes in contact with asphalt.
7. Check burner ignition.

5. Always pave in low range.

NOTE: If paving on cool windy days, it may be necessary to maintain low heat on the screed. To accomplish this reduce the pressure on the propane tank from 15 lbs. (1 bar) to 6 lbs. (0.41 bar). This will provide a low even heat that will not harm the screed. Do not attempt to regulate the burner with the burner valve.

WARNING: Before starting forward with paver make certain that no one is in front of the paver.



STARTING TO PAVE

GENERAL

The paver is capable of placing bituminous base, binder and surface courses, lime or Portland cement stabilized sub-base and graded aggregate materials up to a thickness of 6 inches (20 cm). This paver has a production rate of approximately 250 tons per hour.

This paver is equipped with electric over hydraulic and manual thickness controls and an 8 ft to 15.6 ft (2.44 m to 4.74 m) wide screed. The paver can handle everything such as driveways and small parking lots to large parking areas and secondary roads.

Before starting to pave, keep the following points in mind:

1. Plan the project so that the narrowest passes are first, (the basic width of the paver) leaving the widest pass until last.
2. Make sure to use a reference guideline. This can be a curb, gutter, adjacent mat or a string line. It is important that the first pass be straight. It will be the guideline for the following passes
3. Never run the paver through a pile of mix that has been dumped in front of the machine. Not only will this effect the level of the mat being laid but damage may result.
4. It is the operator's job to guide the truck up to the paver and signal the driver when and how much to dump into the hopper. Truck drivers must maintain a light pressure on his brakes to keep truck from dumping material on the roadway.

NOTE: If the paver is equipped with a truck hitch, the truck driver will not be required to maintain pressure on the brake. Refer to the paragraph **TRUCK HITCH ATTACHMENT** in this chapter for using the truck hitch.

SETTING SCREED TO PAVE

1. Move to the starting position.
2. Extend the screed to the desired width.
3. To set depth, place screed on starter blocks (see Figure 3-24).
4. Level screed with flight screws until neutral position is felt. (Neutral position is when the pressure on the flight screw is the same when screwing either clockwise or counterclockwise.)
5. Set the left or right **SCREED LIFT** switch to the **FLOAT** position. This will remove the hydraulic pressure from the cylinder, allowing screed to float.

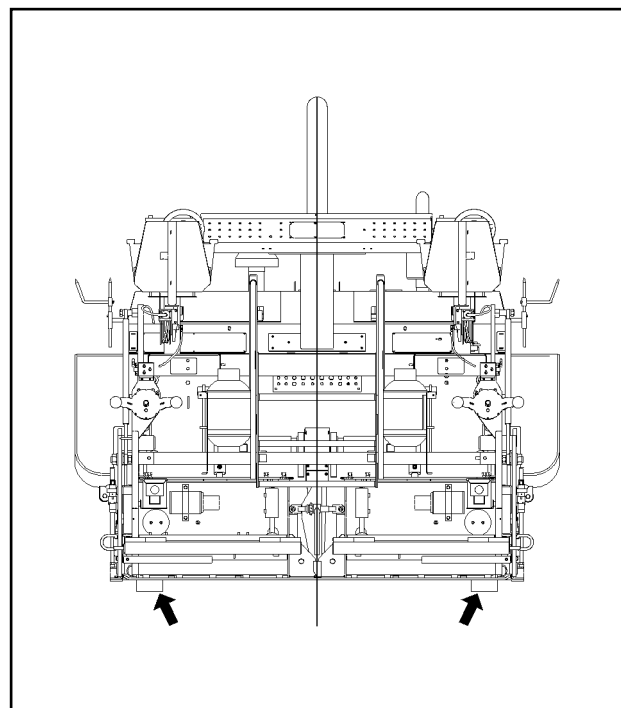

FIGURE 3-24. STARTER BLOCKS

6. Turn flight screw about one complete turn clockwise.
7. To obtain the crown or valley desired refer to Figure 3-25, and loosen hex head nut and two (2) bolts on the slope supports on the right side of the screed. Using the crown handle, depending on the requirement push down for positive crown or pull up for negative valley.

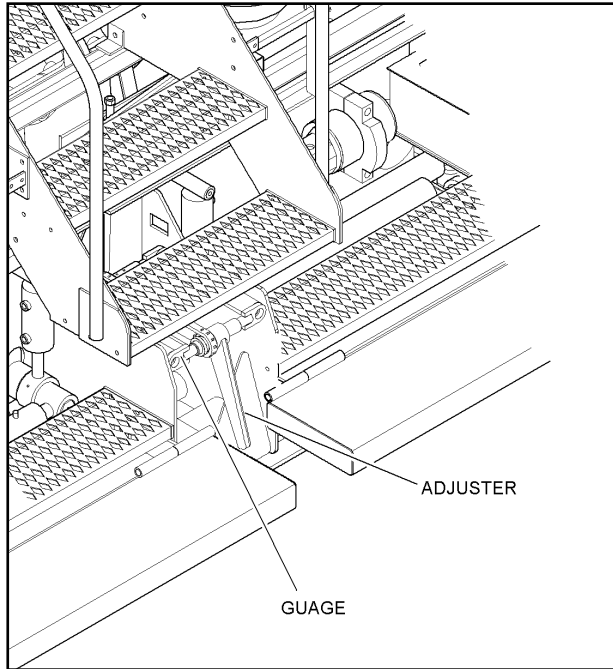

FIGURE 3-25. CROWN ADJUSTMENT LOCATION

8. Use the gauge located on rear of crown adjuster to indicate when screed is level.
9. Set crown control. The screed plate is a one-piece unit that is actually bent to provide the required crown setting (see Figure 3-26).
10. To get exact crown or valley, measure the distance between a flat level surface to the center bottom portion of screed (see Figure 3-26). Make adjustments with crown and valley control.

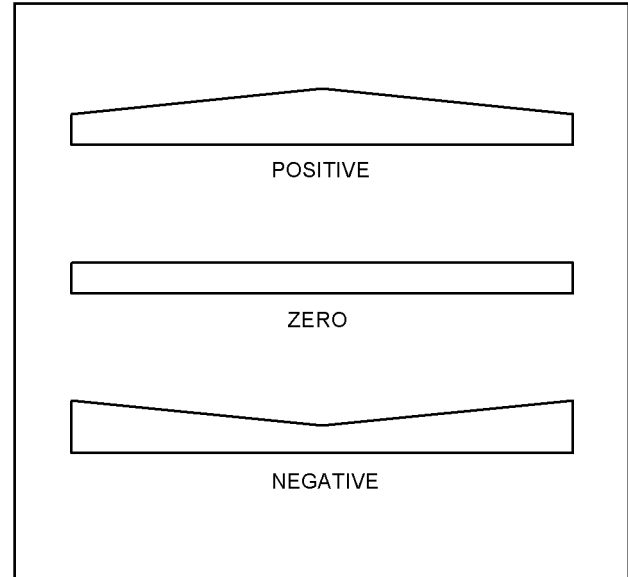

FIGURE 3-26. CROWN SETTINGS

NOTE: Positive crown is when the middle of the mat is raised to permit water to drain to each side. Negative crown is the lowering of the center of the screed plate. Negative crown might be used in an alley where drainage down the center of the alley is necessary.

Crown may be placed in the leading edge and/or the trailing edge of the screed plate. Crown in the leading edge aids material flow under the screed plate only. Trailing edge crown puts a crown in the mat. As an example: trailing edge crown is 0, leading edge crown is 1/8". With this set-up there will not be any crown placed in the mat laid by the paver, however, material flow under the screed plate will be improved.

Trailing edge crown is set at 0 when shipped from the factory. The chain connecting the leading and trailing edge crown control assures that the relationship of the edges remains constant as the trailing edge is changed to meet job conditions.

Section 3 OPERATION



SETTING SCREED ENDGATES

1. On first pass unlock depth screws and lower endgate to about ¼ inch (0.6 cm) of desired depth. This should provide a nice square edge (see Figure 3-27).

NOTE: Most people run Endgates within 1/4" of flush.

2. The scale located on each endgate will show proper setting or depth.
3. Tilt adjusters on endgate are to be set so front of endgate tilts down slightly when screed is lifted. This will allow the endgate to set itself to grade.

NOTE: When paving never let end gate carry the weight of the screed. This will cause screed compaction to vary.

4. During operation, if endgate starts to dig in at front, adjust the tilt so the endgate tilts back.
5. When making a joint, endgate must be set to '0' on scale or where it fits flush with bottom of screed.

NOTE: Keep shoe clean. When making a joint, spray cleaning solvent on runners.

6. On first pass leave about 6 to 8 inches (15 to 20 cm) of unrolled asphalt where joint is being made.
7. In laying a joint, if the joint looks too high or too low, adjust main flight screw on screed about one (1) turn at a time and allow 4 to 5 ft. (1.2 to 1.4 m) of travel to correct itself. (Too much adjustment up or down may cause a roller coaster effect.)
8. If making a cold joint, set endgate down about ¼ inch (0.6 cm), this will give a nice even edge.

SETTING SCREED EXTENSIONS (Used when paving over 8 ft. [2.4 m])

The screed extensions should be heated before making adjustments. Use the wrench provided to make adjustments. When the adjustment is made the pressure on the rear edge of extended screed is the same as on the rear edge of main screed. The result of making this adjustment will be a smooth mat the length of the screed.

1. Heat screed extension before making adjustment to extended width.

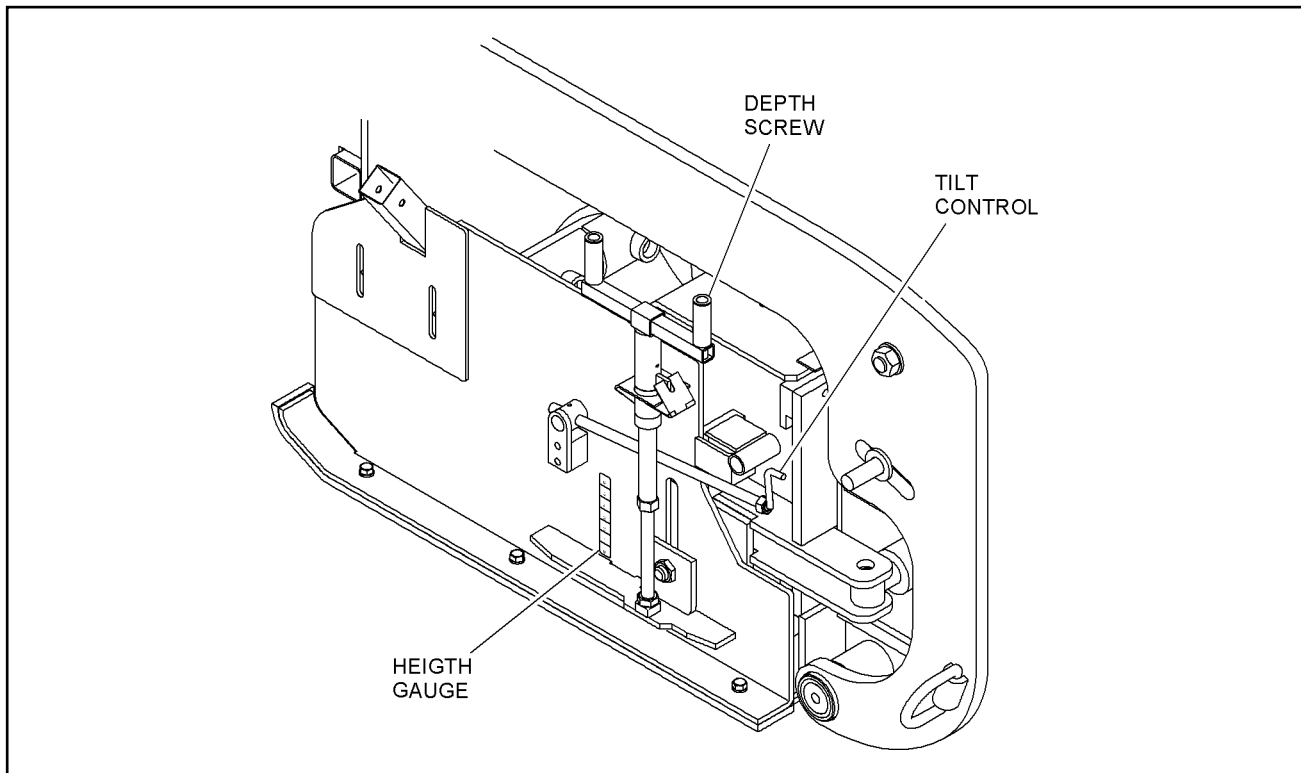

FIGURE 3-27. END GATES

2. Adjust tilt on rear edge of extension by turning adjustment counterclockwise. This is done to give the same amount of compaction on extension and slickness as main screed.
3. If drag occurs in center of screed, then too much pressure is on the screed extension and the extension is carrying all the weight. Correct this by turning the adjustment clockwise until both the screed and the screed extension produce the same mat texture.
6. Open cut-off gates behind auger and start paving. Move slowly at first so adjustments can be made to screed.
7. To prevent excessive handwork, several feet from the end of the pull, Set both the LEFT CONVEYOR AND AUGER and RIGHT CONVEYOR AND AUGER switches to the "Off" (center) position and set LEFT CUTOFF and RIGHT CUTOFF switches to the CLOSE position. Return paver back to starting position to begin next pull. Position and set screed endgate on joint side back to 0 inches or flush with bottom of main screed. Repeat process as done in first pull.

PAVER OPERATION

1. Follow start-up procedures. See ENGINE START-UP.
2. Position paver to start of mat. Adjust screed in accordance with Screed Leveling Instructions.
3. When material starts to discharge from under screed, the SCREED LIFT switches on the dash should be set to the FLOAT position (only from side operating).
4. Open hopper wings into working position. When first starting to pave allow only a partial load of asphalt to enter the hopper.
8. The paver can operate using one side only. However, material from opposite side cannot be augered to the working side. The auger center cover prevents this. It is possible to leave both cut-offs shut and open the end gates on screed. This method is generally used in doing potholes and patching.

CAUTION: Never fold hopper wings fully in when hopper is full of asphalt.



5. Set the LEFT CONVEYOR and RIGHT CONVEYOR switches to the AUTOMATIC position and convey material back to screed. Run from one side only, either the left operator's side or the right.

TABLE OF CONTENTS

	Page
GENERAL INFORMATION	3
ROUTINE MAINTENANCE	3
GENERAL INFORMATION	3
MACHINE LUBRICATION	3
MAINTENANCE SCHEDULE	6
General Information	6
10 Hour or Daily Routine Maintenance	6
After The First 50 Hours and Weekly Routine Maintenance	7
100 Hour or Monthly Routine Maintenance	8
250 Hour or Quarterly Routine Maintenance	8
500 Hour or Semi-Annual Routine Maintenance	8
1000 Hour or Annual Routine Maintenance	9
MAINTENANCE ADJUSTMENTS	9
CONVEYOR FLIGHT CHAIN ADJUSTMENT	9
AUTOMATIC TRACK ADJUSTMENT	10
General	10
CONVEYOR DRIVE CHAIN ADJUSTMENT	10
TORQUE HUB HYDRAULIC MOTOR ADJUSTMENT	10
AUGER DRIVE CHAIN ADJUSTMENT	10
TRACK TENSION PRESSURE	12
PRESSURE CHECK	12
TRACK TENSION RELEASE	12
SCREED EXTENSION TOP GUIDE ADJUSTMENT	12
BATTERY SERVICING	13
ENGINE MAINTENANCE	14
GENERAL INFORMATION	14
ENGINE LUBRICATION OIL	14
Changing the Engine Lubrication Oil	14
Older models	15
New Models	15
Changing The Engine Lubrication Oil Filter	16
FUEL SYSTEM	16
FUEL TANK	16
ENGINE FUEL FILTERS	16
ENGINE AIR FILTER	17
HYDRAULIC SYSTEM	18
GENERAL INFORMATION	18
CHECKING THE HYDRAULIC OIL LEVEL AND ADDING HYDRAULIC OIL TO THE HYDRAULIC OIL RESERVOIR	18
Changing the Hydraulic Oil	19
Changing the Hydraulic Oil Return Filter Element	19
REMOVAL AND INSTALLATION PROCEDURES	20
REPLACING 2-SPEED MOTOR	20
Removal	20
Installation	20
REPLACING DRIVE TORQUE HUB	20
Removal	20
Installation	21
REPLACING TRACK SPROCKET	21
Removal	21
Install	21
REPLACING FRONT IDLER OR BUSHING	21
Removal	21
Installing Front Idler After Replacing Bushings	21
Installing New Front Idler	22

TABLE OF CONTENTS

	Page
ADJUSTING TRACK TENSION	22
REPLACING REAR CONVEYOR SHAFT, BEARINGS, AND SPROCKETS	22
Removal	22
Installation	22
REPLACING FRONT CONVEYOR SHAFT, BEARINGS, AND SPROCKETS	22
Removal	22
Installation	23
REPLACING CONVEYOR WEAR PLATE	23
Removal	23
Installation	23
REPLACING CONVEYOR DRIVE MOTOR	23
Removal	23
Installation	23
REPLACING CONVEYOR TORQUE HUB	23
Removal	23
Installation	24
REPLACING CUTOFF ASSEMBLY	24
Removal	24
Installation	24
REPLACING INNER AUGER DRIVE SHAFT	24
Removal	24
Installation	24
REPLACING AUGER MOTOR	25
Removal	25
Installation	25
REMOVING REAR HOPPER WING CYLINDERS	25
Removal	25
Installation	25
REPLACING HOOD, PUMPS, AND DOUBLE PUMP DRIVE	25
Removing Hood	25
Removing Pumps	26
Removing Pump Drive	26
Removing Inner Drive Coupling	26
Installing Drive Coupling	26
Installing Pump Drive	26
Installing Pumps	26
Installing Piggyback Pumps	26
Installing Hood	26
REPLACING SCREED EXTENSION WEARPLATES	27
Removal	27
Installation	27
REPLACING SCREED MAIN WEARPLATES	27
Removal	27
Installation	27
AUGER CONVEYOR HEIGHT MIN/MAX PILE HEIGHT POD CALIBRATION	27
CALIBRATION PROCEDURE	27
SCHEMATICS	28
TROUBLESHOOTING	59
GENERAL	59
STEERING CONTROL SYSTEM TROUBLESHOOTING GUIDE	62
FAULT CODES	62
Description of Blink Code Algorithm	62
Blink Code Translation	63
STEERING SYSTEM WIRING	64
Wiring Guidelines	64

GENERAL INFORMATION

This section gives the necessary procedures for routine and general maintenance on the Model 8816 Conveyor Paver.

Follow all the Maintenance Schedules and Maintenance Procedures to maintain the machine in top operating order.

ROUTINE MAINTENANCE

GENERAL INFORMATION

MAINTENANCE must be a planned program that includes periodic machine inspection and lubrication procedures.

The MAINTENANCE program must be done, based on the machine "Operating Hours", recorded on the hourmeter, or based on the "Periodic Schedule", which is done at time intervals of weekly, monthly, or yearly.

MACHINE LUBRICATION

Proper lubrication is necessary to maintain the machine at top efficiency. Refer to the lubrication information in Table 4-1 Lubrication Chart. All lubrication points are shown in Figure 4-1.

Section 4 MAINTENANCE

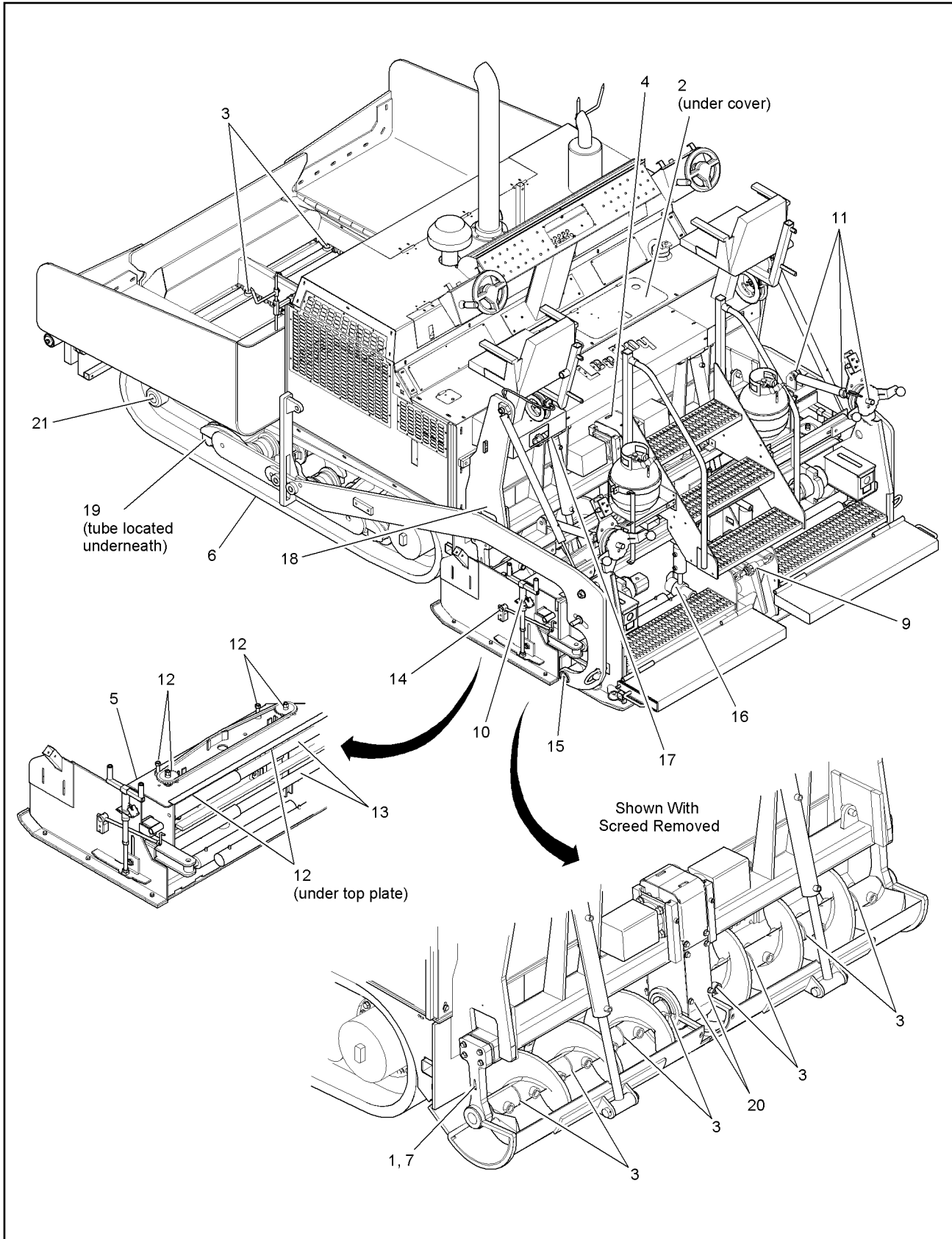

FIGURE 4-1. LUBRICATION POINTS

TABLE 4-1. LUBRICATION CHART

ITEM NO.	TYPE LUB	DESCRIPTION AND LOCATION	INTERVAL
1	A	AUGER, grease fitting on end mount. (End of Day)	Daily
2	A	CONVEYOR CHAIN, left and right side	Daily
3	B	CONVEYOR AND AUGER, as shown	Daily
4	B	AUGER CHAIN, middle of paver	Daily
5	B	SCREED EXTENSIONS, left and right (clean surface)	Daily
6	B	TRACKS, between track pads	Weekly
7	B	CUTOFF PIVOT AT AUGERS	Daily
8	B	SPRAY ANY PART OF MACHINE THAT CONTACTS ASPHALT	Daily
9	A/B	SCREED CROWN, on chain and turnbuckles	Weekly
10	A	DEPTH SCREW (grease first in lock position, unlock and turn 180° and grease)	Weekly
11	A	MAIN FLIGHT SCREWS BALL SOCKET & NUT	Weekly
12	A	ALL SCREWS ON EXTENSION AND BEARING	Weekly
13	A	TUBES AT CHROME ROD EXTENSIONS	Weekly
14	A	TILT SCREWS	Weekly
15	A	SCREED PIVOT	Weekly
16	A	SLOPE CYLINDER PIVOT	Weekly
17	A	CUTOFF CYLINDER ROD ENDS	Weekly
18	A	AUGER RAISE AND LOWER SLIDES	Weekly
19	A	FRONT AND REAR CONVEYOR IDLER & DRIVE TUBES	250 HRS
20	A	GREASE FITTING ON REAR AUGER BEARINGS	Daily
21	B	IDLER OIL, check level	Monthly

LEGEND

- A GREASE WITH SHELL AVANIA EP GREASE 2 OR EQUIVALENT
- B SPRAY WITH FUEL OIL OR CHAIN LUBE

Section 4 MAINTENANCE



MAINTENANCE SCHEDULE

General Information

The Maintenance Schedule lists the recommended time intervals between machine maintenance inspections and lubrication procedures. Table 4-1 gives inspection and lubrication information for the Model 8816 Conveyor Paver.

The "Hour" and "Periodic" time periods list most service intervals. The maintenance schedule begins with ten hours, or daily, maintenance intervals and continues through the 1,000 hours, or annual, maintenance schedule intervals.

NOTE: If the machine is operated more than ten hours per day, follow the "Hour" schedule. If the machine is operated less than ten hours per day, follow the "Periodic" schedules, where they apply.

Preventive maintenance on the 8816 Conveyor Paver will provide years of trouble-free operation. Adjustment can be performed in the field with ordinary hand tools. Engine preventative maintenance, other than oil, air, and fuel filter changes is not covered in this section. Refer to engine operator's manual for engine service information.

NOTE: For your convenience there is an oil drain hose located inside of right hand side cover on machine. Remove small access cover and stick hose thru hole in side. (Later Models).

IMPORTANT NOTICE!

The changing of oil and cleaning of the paver should only be done in a designated area that can contain the oil and chemicals involved in any maintenance requirement. These by-products should be discarded in accordance with environmental regulations.

CAUTION: Do not substitute fasteners of any kind unless the fasteners are equal in size and grade as original equipment.



NOTE: When performing any routine maintenance such as 50, 100, 250, 500, and 1000 hours, always include previous routine maintenance hours to the higher hourly schedule.

10 Hour or Daily Routine Maintenance

1. Cleaning the paver at the end of the working day while the machine is still hot is very important. A paver that is continuously left with mix stuffed in every corner is going to increase maintenance costs. Scrape off mix and spray cleaning solvent or release agent on the screed plate, hopper, etc., any place that has come in contact with the mix. Spray down the conveyors while they are running. All cleaning should be performed while the machine is hot.

NOTE: For cold weather, keep conveyor flight chains properly oiled with cleaning solvent or release agent. This will prevent conveyor bars from sticking. Neglect could result in conveyor bar damage/or drive chain failure.

CAUTION: If mix is allowed to remain in the machine overnight, possible damage can result on start-up the next day. Poor housekeeping will increase maintenance costs.



2. Keep the fuel tank full to keep condensation from forming. Fill at end of day.
3. Perform engine preventative maintenance as described in your engine operator's manual. Any engine preventative maintenance should always begin with an oil check.
4. Lubricate thickness control screws with grease or anti-seize to keep the control screws working smoothly.
5. Grease extension slides with multipurpose grease or spray with cleaning solvent or anti-seize at points shown (see Figure 4-2).

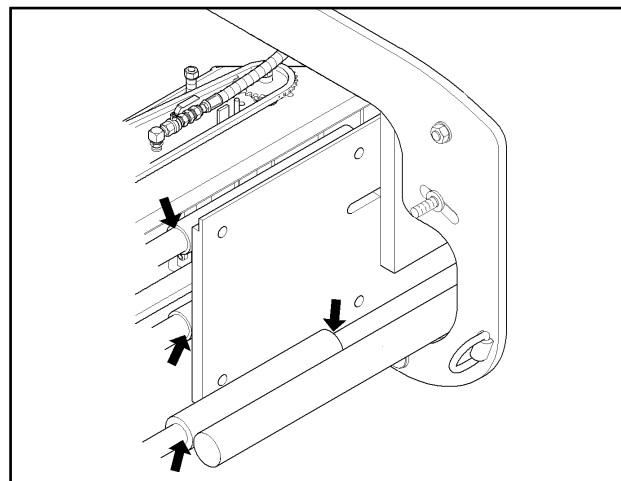

FIGURE 4-2. EXTENSION SLIDE LUBRICATION

After The First 50 Hour and Weekly Routine Maintenance

1. Check hydraulic oil and add if necessary.
2. Adjust conveyor chains (see CONVEYOR DRIVE CHAIN ADJUSTMENT). After adjustment, drag chains should be about 1/2" from rear square tubing of main frame. Do not let chains run more than 2" below main frame sides.

CAUTION: The paver hydraulic system requires clean, contaminant free oil. Take care when working with the hydraulic system to insure it is completely clean. (Use AW #68 Hydraulic Oil.)



3. To fill, remove top of return filter and pour thru, located on top of reservoir. If you have a hydraulic or air pump, you can fill at charge filter. (Remove cap and fill.)

WARNING: Do not smoke when observing battery electrolyte level. The fumes can explode. Electrolyte is an acid that can burn if it contacts skin or eyes. If contact is made, flush area immediately with water.



4. Check all battery connections and remove any corrosion that is present. (Check cables daily.)
5. Check air cleaner, if the engine is equipped with a dry type element. Improperly serviced air cleaners wear out engines--FAST! In just a few hours a small amount of dirt will wear out a set of piston rings! Refer to your engine operator's manual for service information. Also, perform any other engine preventative maintenance as described in the engine operator's manual.
6. For both sides of the screed, lubricate all grease fittings on the flight screw, the fitting on the depth screw, and the fittings on the flange bearings located on top of the extension screed (see Figure 4-3). Grease nuts on extension screws.
7. Change engine oil and filters. Use drain hose on right side of machine where access hole is located (later models).
8. Check auger chains, lubricate, and adjust.

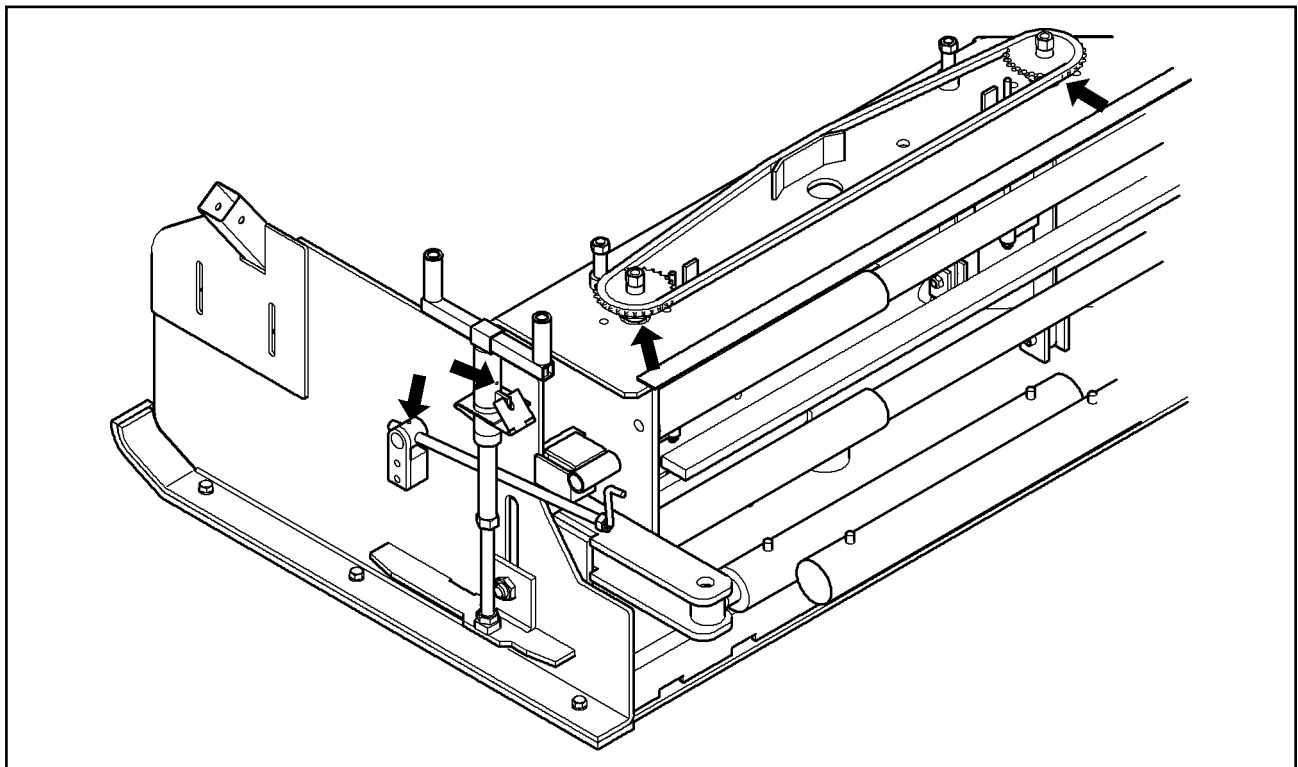

FIGURE 4-3. SCREED ASSOCIATED LUBRICATION POINT LOCATIONS

Section 4 MAINTENANCE



100 Hour or Monthly Routine Maintenance

1. Check oil level in the torque hub, by removing the plug at the 3 o'clock position. If oil comes out, no oil is needed. Insert plug and tighten. If oil does not come out, remove the plug at the 12 o'clock position and fill torque hub with 90-wt. gear oil until oil starts to appear at the other hole. Replace both plugs and repeat process on other torque hub (see Figure 4-4).
2. Replace dry type air filter, if equipped. Refer to your engine operator's manual for service information.
3. Change engine oil. To assure complete removal of contaminants in the oil, perform the oil change while engine is warm.

After draining used oil, clean and reinstall drain plug and fill crankcase to the full mark with manufacturer's recommended oil. Change oil filter at every other oil change (15W-40 Motor Oil).

4. Change engine oil and filters.
5. Perform any other engine preventative maintenance as described in the engine operator's manual.
6. Check and adjust all chains, as required (see MAINTENANCE ADJUSTMENT).

250 Hour or Quarterly Routine Maintenance

1. Perform the 250-hour preventative maintenance as described in the engine operator's manual.
2. Change charge filter for main pumps.
3. Change return filter on hydraulic tank.

500 Hour or Semi-Annual Routine Maintenance

1. All bearings are sealed and have grease fittings. These should be greased with multi-purpose grease using a hand grease gun. Be careful to avoid blowing the seals.

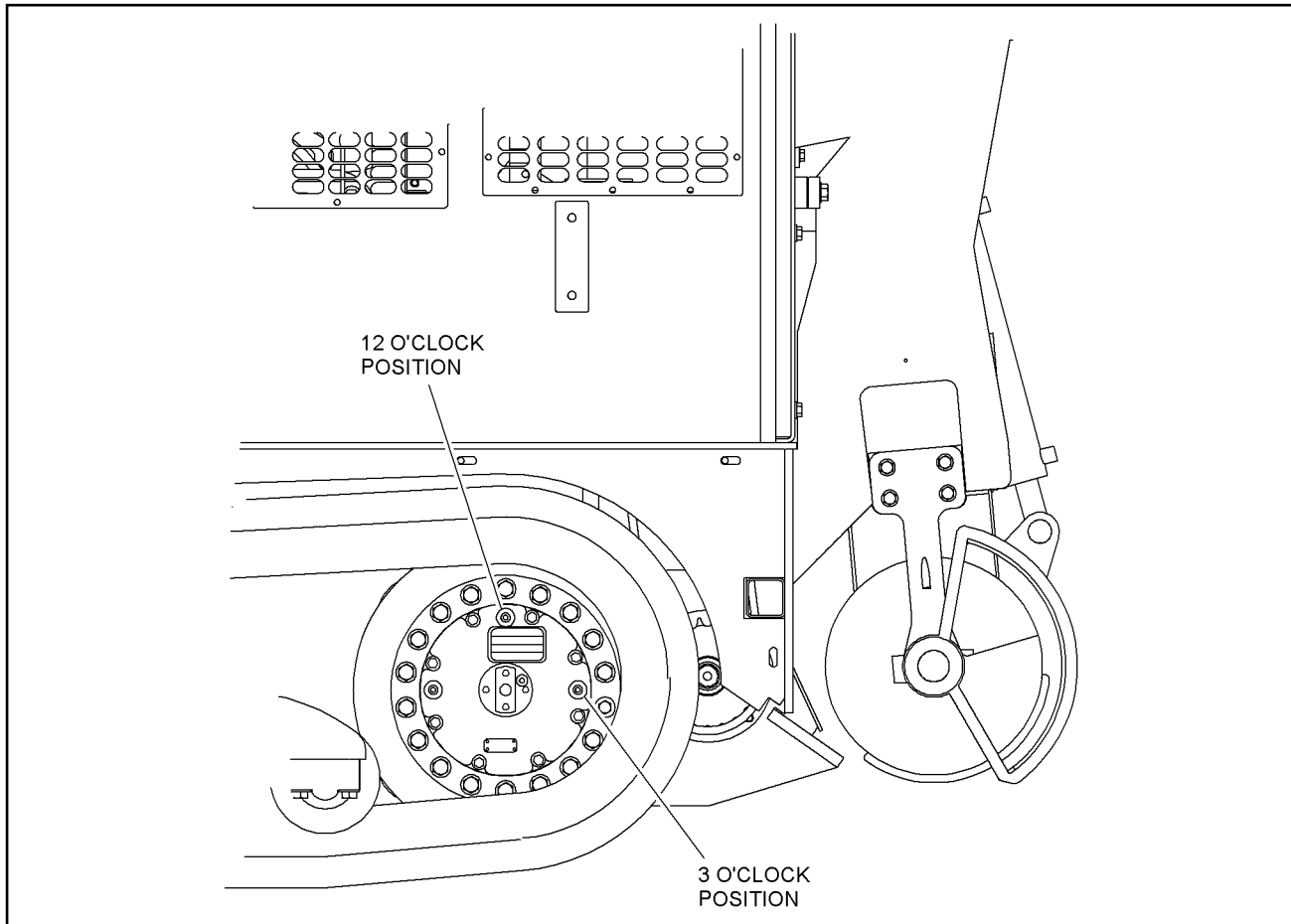

FIGURE 4-4. TORQUE HUB LUBRICATION

2. Perform the 500-hour preventative maintenance as described in the engine operator's manual.
3. Drain the hydraulic tank. A drain plug is located on the bottom of the tank for this purpose. The recommended hydraulic oil is AW #68 Hydraulic Oil.
4. Change oil in conveyor torque hubs, use 90 wt.
5. Change oil in drive torque hubs, use 90 wt.
3. Anytime the paver has been repainted or the decals have been removed, damaged or can't be read, a new set of decals should be ordered and reinstalled for safe operation.
4. Change oil in conveyor torque hubs, use 90 wt.
5. Change oil in drive torque hubs, use 90 wt.

1000 Hour or Annual Routine Maintenance

1. Drain the hydraulic tank. A drain plug is located on the bottom of the tank for this purpose. The recommended hydraulic oil is AW #68 Hydraulic Oil.
2. Perform the 1,000-hour preventative maintenance as described in the engine operator's manual.

MAINTENANCE ADJUSTMENTS

CONVEYOR FLIGHT CHAIN ADJUSTMENT

Use the following procedure to make adjustment:

NOTE: Front of machine must be run up on ramps to perform this adjustment.

1. Loosen the locknut and the bolt holding the Adjustment Roller Assembly.

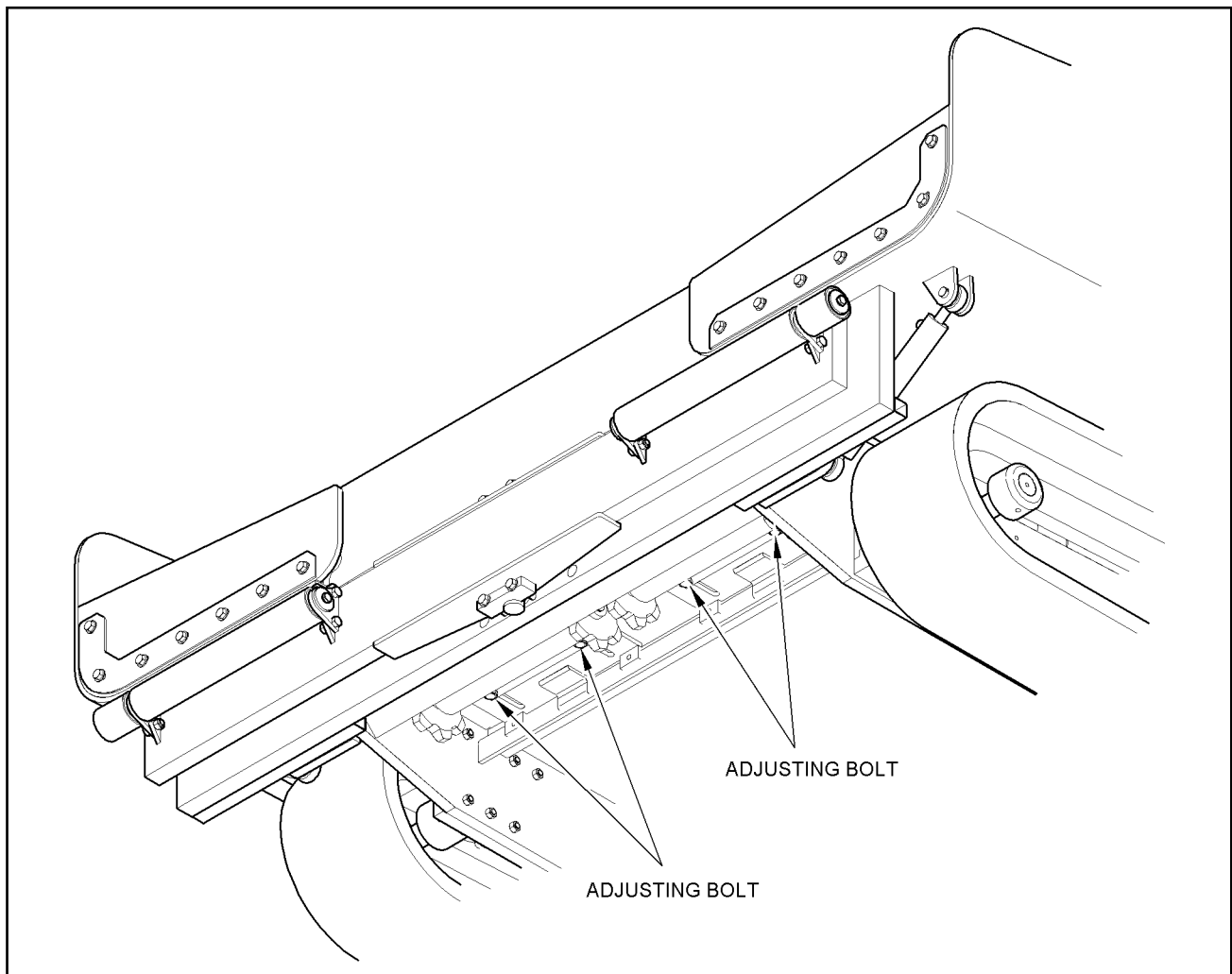

FIGURE 4-5. ADJUSTING BOLT

Section 4

MAINTENANCE



2. Turn adjustment bolts alternately on both sides of the conveyor. The pressure on the chain will be noticeable as the bolts are tightened. (LeeBoy recommends turning one bolt one half turn, then the other bolt one half turn. Continue alternating tightening until chains are tight).

NOTE: When correctly adjusted, drag chains should be ½" away from rear frame square tube.

3. After the conveyor chain tension is set, tighten locknuts.
4. If the adjustment bolts have been run out, it will be necessary to remove a link in the conveyor chains. This repair should bring the adjustment bolts back to full travel.
5. Repeat steps 1 through 4 for the opposite side.
6. Grease front and rear conveyor tubes by removing plug and installing a grease fitting to fill tube. This will grease between the two bearings on each side of tube. After filling reinstall plug.

NOTE: If conveyor bar is damaged, the complete link with bar must be removed.

AUTOMATIC TRACK ADJUSTMENT

General

NOTE: Failure to maintain adequate throttle setting may cause improper adjustment to tracks.

NOTE: When first starting machine for the day, let engine warm up. Before moving rev engine full (for proper track tension) and then throttle back to at least one-half throttle.

CAUTION: When backing this machine with load, maintain at least a one-half throttle setting. Failure to do so may cause improper track tension, resulting in poor performance and damage.



Hydraulic adjustment cylinders are automatic and provide even tension on track that prevents excessive wear to paver undercarriage. This feature, however, will require the operator when backing with load to maintain at least one-half throttle setting. Hydraulic pressure below one-half

throttle is not adequate to maintain track adjustment.

Track Tension Pressure 900 psi.

Track Tension Relieving 1500 psi.

CONVEYOR DRIVE CHAIN ADJUSTMENT

1. Operate conveyors.
2. Look at drive chain from side of machine at rear of track. If drive chain has excessive loose motion in it, adjustment is necessary.
3. If adjustment is necessary, continue to operate conveyors at fast speed and loosen the jam nuts (Figure 4-6, Item 2) on the chain adjusters. Turn the chain adjusters (1) until the whip in the drive chain disappears. Do not over tighten. Leave about ¼" of slack in chain.
4. Once adjusted, tighten jam nuts.
5. Perform the same check on the opposite conveyor drive chain.
6. Keep chains clean from buildup, adjusted properly, and lubricated.

TORQUE HUB HYDRAULIC MOTOR ADJUSTMENT

NOTE: The high gear adjustment screw is located on bottom of drive motor.

Tracking adjustment on the high side gear is performed by adjustment screw on bottom of hydraulic motor. The adjustment on the motor for the fast track must be screwed in to equalize track speed.

NOTE: High gear operation requires the 2-SPEED HIGH/LOW switch on either side of the dash panel to be in the HIGH position.

1. With paver running, set either 2-SPEED HIGH/LOW switch to the HIGH position. Red 2-SPEED LIGHT will be illuminated.
2. Adjust screw on bottom of hydraulic motor.
3. Finalize adjustment by making one-quarter turns at a time until correct adjustment is made.

AUGER DRIVE CHAIN ADJUSTMENT

1. The auger chains should be just snug, not loose. To check, remove top part of auger cover. To tighten chains, loosen horizontal bolts (Figure 4-7, Items 1 & 2) in slots provided for taking play out of forward and rear motion.

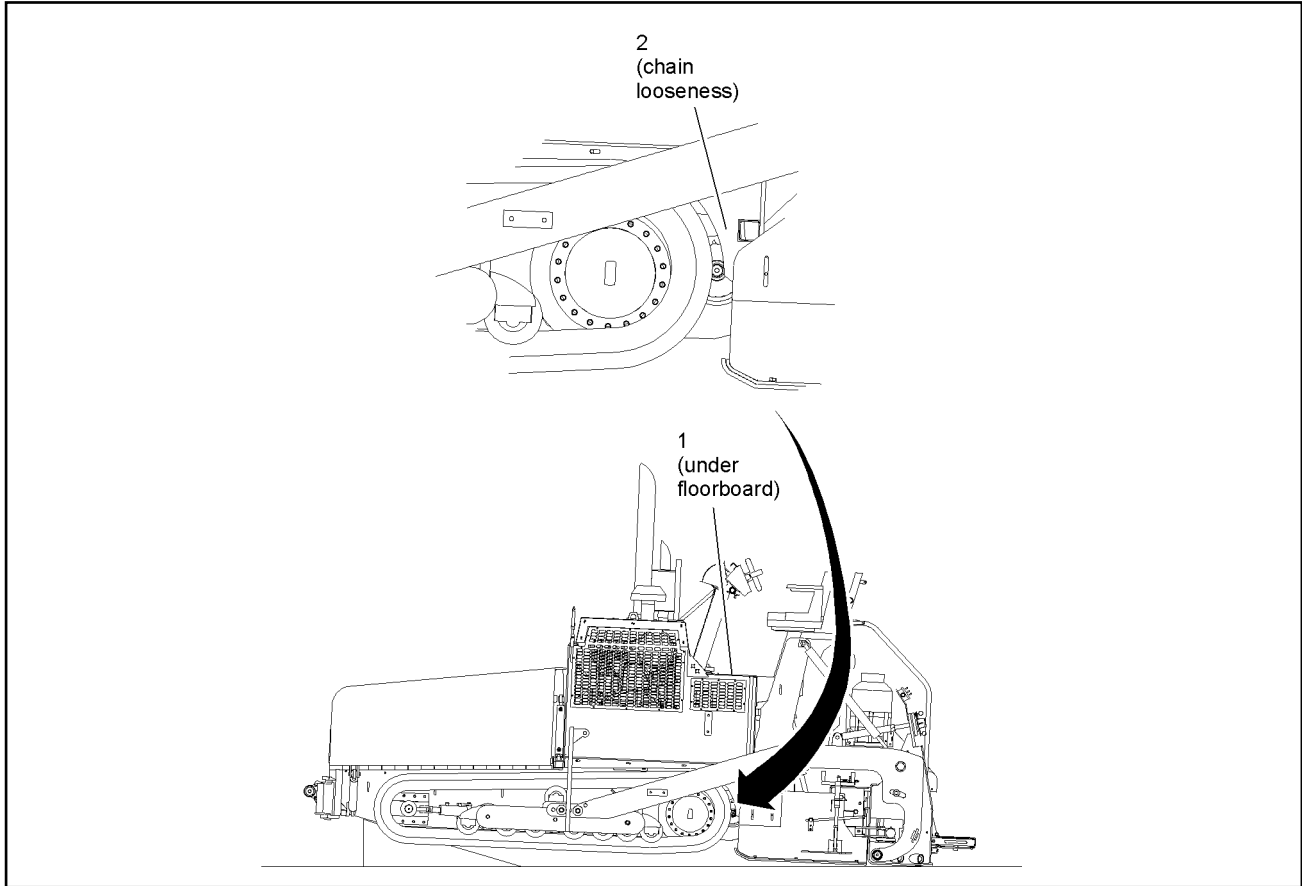

FIGURE 4-6. CONVEYOR CHAIN ADJUSTING BOLTS

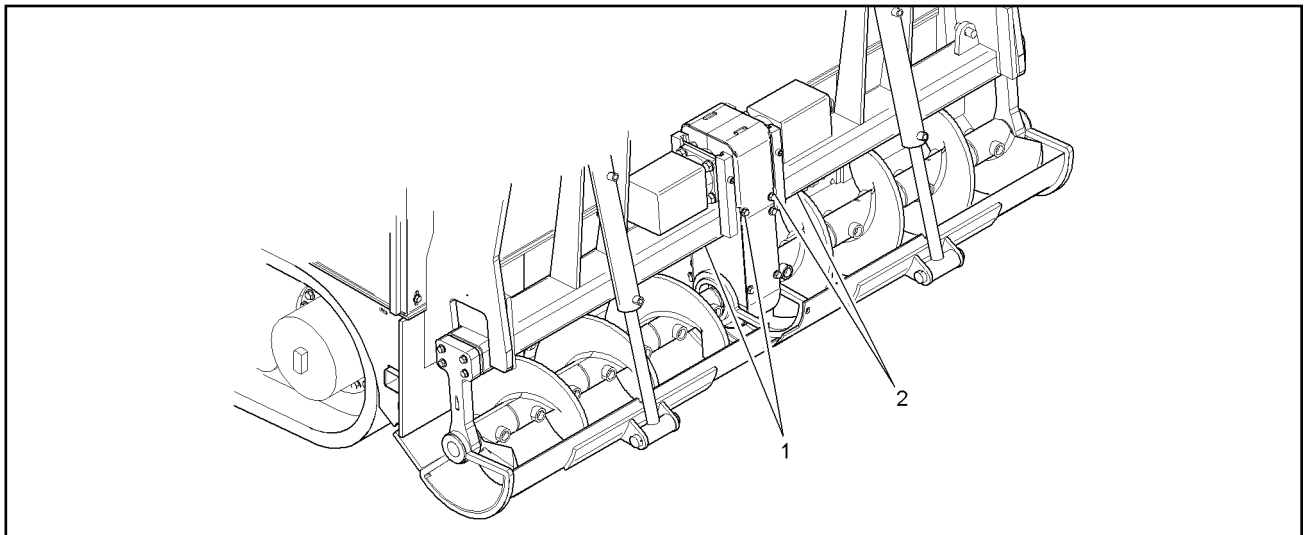

FIGURE 4-7. AUGER CHAIN ADJUSTING BOLTS

2. To adjust chains for the right auger, use bolts (2). For left auger adjustment use bolts (1). Loosen jam nuts and turn adjuster counterclockwise to tighten chain.
3. Use bolt to adjust tension on chain.
4. Once adjusted, tighten jam nuts on adjustment bolts (see Figure 4-7). Once chain adjusters are tight, snug up horizontal adjusters and then jam nuts.

Section 4 MAINTENANCE



TRACK TENSION PRESSURE

PRESSURE CHECK

All part item numbers in the following procedure refer to the parts list for the SPROCKET DRIVE TRACK SYSTEM and the associated drawing in the parts manual.

NOTE: Relief pressure is set at 1500 PSI to release pressure on idler. Pressure reducing valve is set at 900 PSI for track tension.

1. To check pressure, connect a 2000 PSI gauge at one of the hoses going to the track tension cylinder.

TRACK TENSION RELEASE

1. Locate manifold top right of hydraulic manifold on tank to release track tension.

CAUTION: Do not tamper with adjustment part of relief cartridge.



2. Back relief cartridge out of the aluminum block about three turns or until pressure release is heard. Do not tamper with adjustment for tension.

3. Make sure cartridge is tightened before moving machine.

NOTE: Track tension is controlled by a pressure-compensating pump. The pump is operating all cylinders. A pressure-reducing valve is installed in the track tension manifold to reduce pressure to 900 PSI.

SCREED EXTENSION TOP GUIDE ADJUSTMENT

1. Using the screed LEFT EXTENSION and RIGHT EXTENSION IN/OUT switches, run the screed extension out by setting switches to the OUT position.
2. Locate the nine ½" bolts that hold top guide on.
3. Loosen bolts holding guide and drive guide down tight against slide by using a blunt punch. Use a jack, and raise extension up so that it fits the bottom guide level. Adjust top guide.
4. Run extension out and grease slide with multi-purpose grease before working.

NOTE: Slide should be greased daily to prevent wear.

5. Tighten the nine ½" bolts securing guides to a torque of 75 ft. lbs. (100 N.m).

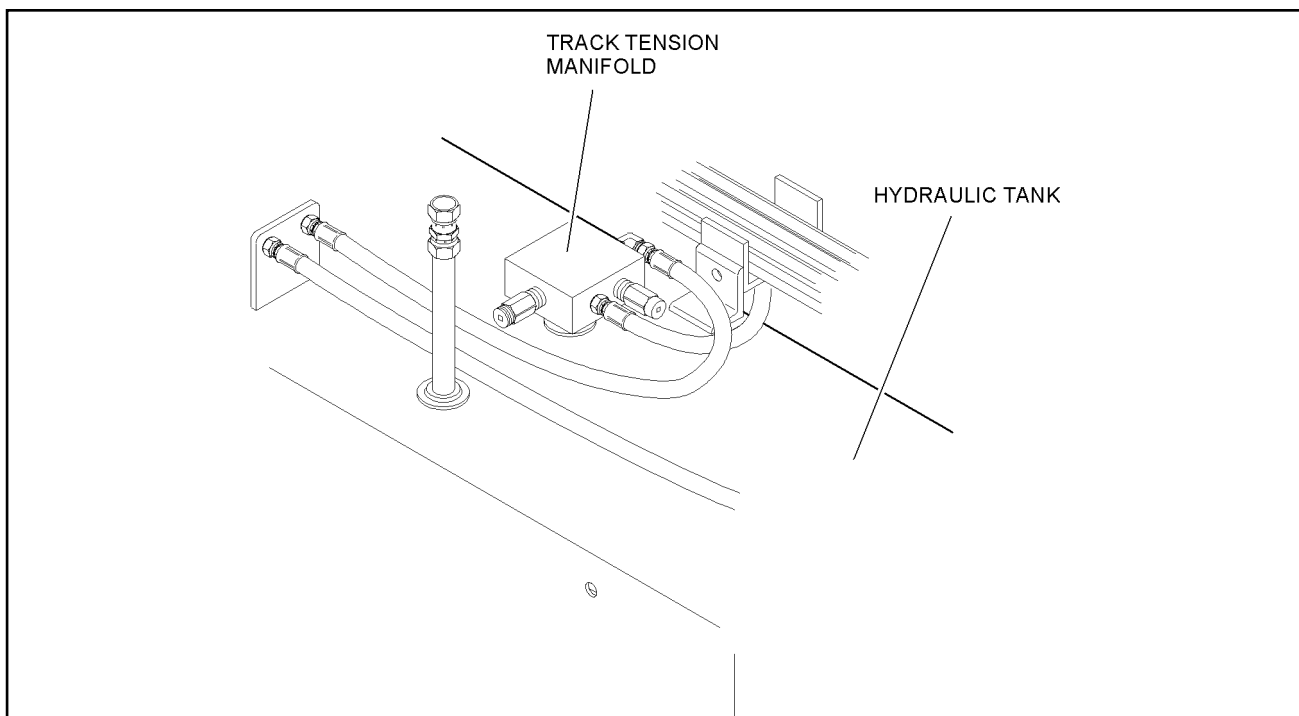

FIGURE 4-8 TRACK TENSION MANIFOLD

BATTERY SERVICING

WARNING: Batteries contain sulfuric acid and normally produce explosive gases which can cause serious injury. Therefore, do not allow flames or sparks to come near the battery. When charging or working near a battery, always shield your face and protect your eyes. In case of acid contact with skin or eyes, flush immediately with water for a minimum of 15 minutes and get prompt medical attention. If acid is swallowed, call a physician immediately.



The paver electrical system is a 12-volt negative ground system. Keep sparks and flames away from

the batteries as electrolyte gas is highly flammable.

NOTE: When replacing the batteries, discard the old batteries properly. Open cover at front of hood standing in hopper to access batteries

CAUTION: When servicing the electrical system or welding on the machine, always turn the MASTER switch to the OFF position to disconnect the ground from the batteries to prevent damage to the machine electrical system.



Before connecting the batteries, turn off the Master Switch, located underneath the main dash panel. Be certain that the terminals and battery posts are

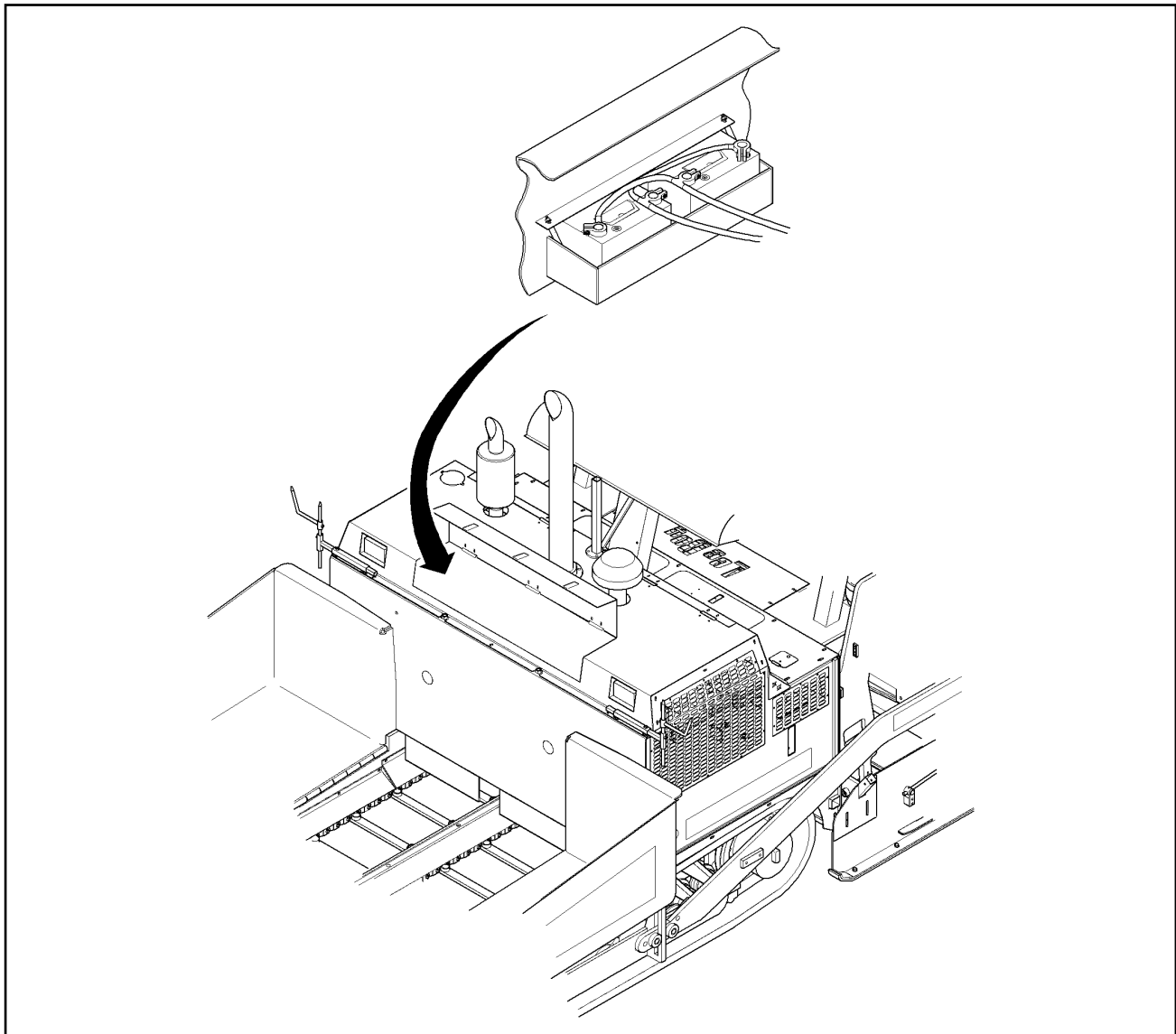

FIGURE 4-9 BATTERY

Section 4

MAINTENANCE



thoroughly cleaned and that the battery cable terminals are tight. Dirty or loose connections can create high electrical resistance and permit arcing, which will quickly burn and pit terminals and posts.

NOTE: The electrical system is a negative ground system. Connect the positive (+) cable to the positive (+) post of both batteries. Connect the ground cable to the negative (-) post of both batteries. It is advisable to disconnect the negative (-) cable first and connect it last. Reversed polarity can damage the electrical system.

Keep the battery clean by washing it off whenever dirt builds up is excessive. If corrosion is present around terminal connections, remove them and wash with ammonia solution or a solution consisting of 1/4 lb. (0.11 kg) baking soda added to one quart of warm water. Make certain the vent caps are tight to prevent solution from entering the cells. After cleaning, pour clean water over the battery and surrounding area to wash the solution away. Check vent cap breather openings to make sure they are open.

Be sure to keep the battery fully charged during cold weather to keep it from freezing. Freezing weather has little affect on a fully charged battery.

When connecting a booster battery, if necessary for cold weather starting, connect one end of the first jumper cable to the positive (+) terminal of the dead battery and the other end to the positive (+) terminal of the booster battery. Connect one end of the second jumper cable to the negative (-) terminal of the booster battery and the other end to the frame of the machine with the dead battery.

The alternator supplies electrical current for charging the battery and ample electrical power to the electronic controls. The built-in regulator in the alternator controls the voltage output. If for any reason the wires must be disconnected from the alternator, mark them so that they can be reconnected properly. Use the following precautions to prevent damage to the alternator and/or regulator:

1. An alternator is never to be polarized. Never ground any alternator terminals or circuits.
2. Always disconnect the battery before disconnecting or connecting the alternator. Never disconnect the alternator with it operating. Be certain the wiring is properly connected before connecting the battery.

3. Always connect a booster battery in the proper polarity. Negative (-) to negative (-) and positive (+) to positive (+).

ENGINE MAINTENANCE

GENERAL INFORMATION

The following engine maintenance information will cover engine general maintenance procedures most often required.

For additional, very specific, engine maintenance information, see the current "OPERATION AND MAINTENANCE MANUAL" - Cummins engine.

ENGINE LUBRICATION OIL

Checking the Engine Lubrication Oil Level

The engine lubrication oil must be kept at a level above the "ADD" mark, but not above the "FULL" mark, on the engine lubrication oil dipstick.

To accurately check the engine lubrication oil level, put the machine in a "level" position and stop the engine. Clean the area around the engine lubrication oil dipstick before removing the dipstick from the engine. Wait five minutes, after engine shutdown, before removing the dipstick from the engine and checking the oil level.

NOTE: The above procedure will help to remove the possibility of filling the engine with too much lubrication oil, by allowing the oil to return to the oil pan.

WARNING: Stop the engine before checking the engine lubrication oil level. With the engine running, hot oil can be thrown causing serious injury.



Changing the Engine Lubrication Oil

The engine lubrication oil must be changed according to the interval given in the current Cummins Diesel engine "OPERATION AND MAINTENANCE MANUAL".

NOTE: The color of the engine lubrication oil can not be used as an indication of the need for a engine lubrication oil change. The use of an engine lubrication oil "analysis service" is the only alternate reason for not following the required engine lubrication oil change schedule.

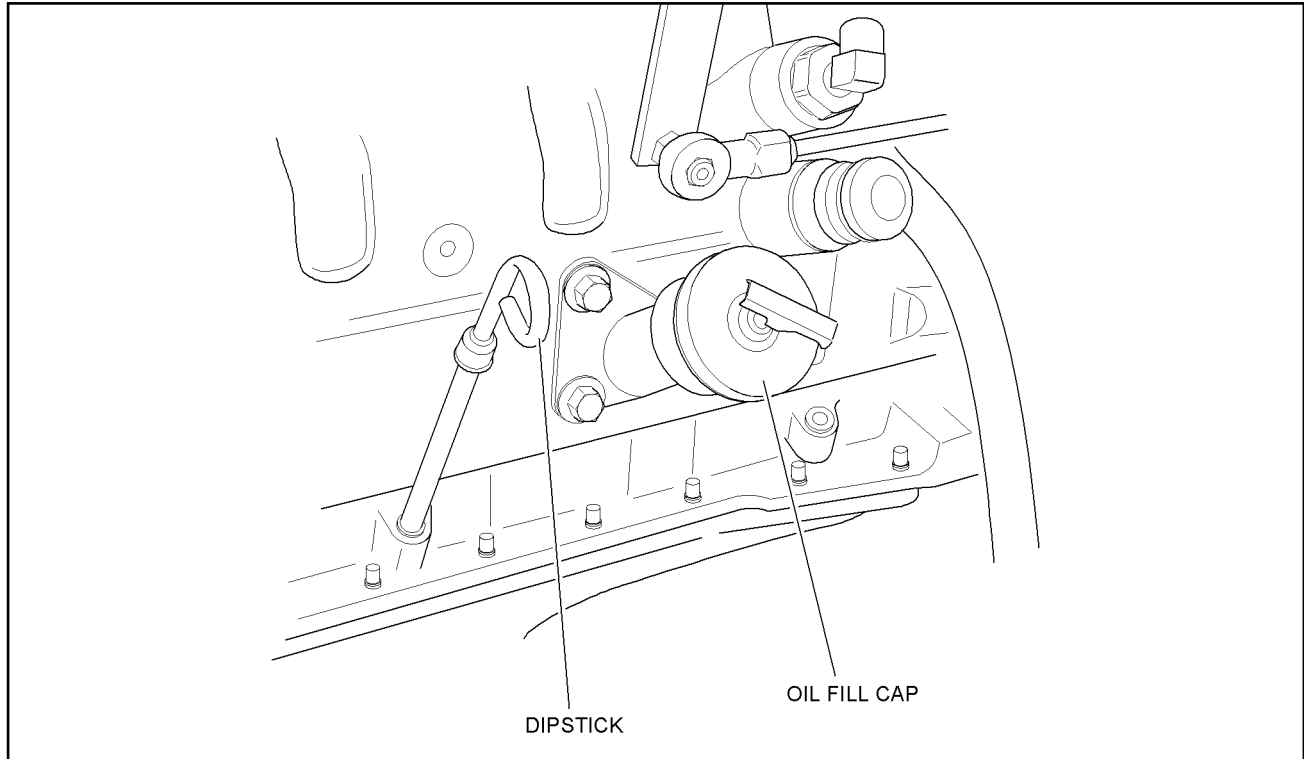

FIGURE. 4-10 ENGINE OIL CAP AND DIPSTICK

WARNING: Do not change the engine lubrication oil when the engine and lubrication oil are hot. Change when warm only. Hot oil can cause serious injury.



CAUTION: Do not change the engine lubrication oil with the engine "running". Serious engine damage, or failure will occur. Clean the area around the engine lubrication oil dipstick and oil filler cap before removing the dipstick, or oil filler cap.



Older models

With the engine "stopped", and the engine lubrication oil "warm", proceed as follows:

1. Clean the area around the engine lubrication oil drain plug found on the engine oil pan.
2. Place a container, having a capacity sufficient to hold the drained oil, directly under the engine lubrication oil drain plug.
3. Carefully remove the engine lubrication oil drain plug.
4. Drain all of the engine lubrication oil into the container.

5. Clean, install and carefully tighten the lubrication oil drain plug.

CAUTION: Do not overtighten the drain plug.



6. Fill the engine with 12 qts (11.3 liters) of 15W-40 oil.
7. Install the engine lubrication oil dipstick.

New Models

NOTE: New models have oil drain hose installed to make changing oil easier.

1. Remove access cover on right side.
2. Locate oil drain hose and stick thru hole in side.
3. Remove cap on end of hose and drain into container sufficiently large to hold the oil.
4. Install cap back on hose and slide hose back inside.
5. Fill the engine with 12 qts (11.3 liters) of 15W-40.
6. Install the engine lubrication oil dipstick.

Section 4

MAINTENANCE



CAUTION: Do not start the engine before changing the engine lubrication oil filter. Follow the procedures given in this section and in the current Cummins engine manual.



Changing The Engine Lubrication Oil Filter

The engine lubrication oil filter must be changed when the engine lubrication oil is changed.

WARNING: Do not change the engine lubrication oil when the engine and lubrication oil are hot. Change when warm only. Hot oil can cause serious injury.



CAUTION: Do not change the engine lubrication oil filter with the engine running. Serious engine damage, or failure, will occur.



With the engine "stopped" and filled with new engine lubrication oil, proceed as follows:

1. Wipe the area around the engine lubrication oil filter element and its mounting base, with a clean cloth.
2. Place a container under the filter element.
3. Use a filter removal wrench to loosen and remove the filter element by turning it in a counterclockwise direction of rotation. Drain and discard the removed filter element.

NOTE: Be sure the used rubber gasket is removed and discarded with the filter element.

4. Wipe the inside area of the lubrication oil filter head using a clean lint free cloth.
5. Put clean engine lubrication oil on the rubber gasket area of the new filter element. Fill the new filter element with correct, new, and clean oil.
6. Install the new filter element onto the filter head. Carefully tighten the filter element, by hand only.

NOTE: Tighten the filter element as directed on the filter element, by the filter manufacturer.

FUEL SYSTEM

FUEL TANK

The fuel level is indicated on the dash panel FUEL gauge and indicates the amount of fuel in the tank. Fill the fuel tank "FULL". Also fill the tank, to "FULL", before the machine is stored for the night to reduce the accumulation of moisture, in the tank, from condensation.

WARNING: The operator must be off of the machine while fuel is added. No smoking while filling the fuel tank. All fuels for internal combustion engines are flammable. Fill the fuel tank only in a designated area with good ventilation. Have a fire extinguisher available.



Never fill the tank near an open flame, or near equipment that can create sparks. Never check fuel level or check for fuel leaks with an open flame.

ENGINE FUEL FILTERS

The fuel filter elements must be replaced as directed in the current Cummins engine manual. Replace the fuel filters using the following "general" procedure and very specific information given in the current engine manual.

WARNING: Diesel fuel is very flammable. Use extra caution.



Do not change the fuel filters with the machine running.

Do not change the fuel filters in an area near an open flame.

Do not smoke while changing the two fuel filters.

Do not spill fuel.

1. Stop the engine.
2. Put a container under the fuel filter, before removing the filter element.
3. Wipe the area around the fuel filter element and the element mounting head, using a clean lint free cloth.
4. Use a filter removal wrench to loosen and remove the element, by turning the element in a counterclockwise direction. Drain and discard the removed element.

5. Wipe the inside area of the filter head with a clean "lint free" cloth. Fill the "new" fuel filter element completely full of the correct and clean fuel. Put clean fuel on the element rubber gasket.
6. Install the "new" fuel filter element onto the filter head. Carefully tighten the element by hand only.
7. Repeat the above procedure for second fuel filter.

CAUTION:  Tighten the fuel strainers or the fuel filter elements as directed on the filter element, by the filter manufacturer. Do not overtighten the fuel filter elements onto the filter heads.

8. Start the engine and check for ANY fuel leaks.

WARNING:  Stop the engine immediately if any fuel leakage is noted. Do not start the engine until the leakage problem is corrected.

ENGINE AIR FILTER

The engine inlet air filter assembly uses a replaceable filter element.

CAUTION:  The air filter element should be replaced one time for each 100 hours of machine operation, or monthly, for a machine which is operated under "normal" conditions, or more often for a machine that is operated under "very severe conditions". Never operate the engine without an air cleaner element installed. Do not service the air cleaner element while the engine is "running".

Use the following procedures to service the air cleaner element:

1. Remove the rear cover air filter.
2. Remove the primary and secondary elements and discard.
3. Clean the inside of the air cleaner body with a clean cloth.

CAUTION:  Severe engine damage can occur if engine is operated without air filter properly installed.

4. Carefully install the new air filter elements into the canister.
5. Install the rear covers on the canister.
6. Check all the clamps for intake air at filter and turbo to make sure everything is tight and in contact.

Section 4 MAINTENANCE



HYDRAULIC SYSTEM

GENERAL INFORMATION

The hydraulic motors and the hydraulic cylinders use the same hydraulic oil reservoir and hydraulic oil supply.

CHECKING THE HYDRAULIC OIL LEVEL AND ADDING HYDRAULIC OIL TO THE HYDRAULIC OIL RESERVOIR

Check the hydraulic reservoir oil level, one time each day, by the sight glass on the reservoir. Check the oil level when the hydraulic oil is at "normal" operating temperature only.

WARNING: Do not loosen, or remove, the hydraulic oil reservoir filler cap when the hydraulic oil is "HOT". Always loosen the filler cap slowly to relieve any pressure in the hydraulic oil reservoir. Only loosen the filler cap when the oil is at a "WARM" temperature.



CAUTION: Never start engine with return filter head top off.



CAUTION: Do not over fill the hydraulic oil reservoir.



Do not use unfiltered hydraulic oil. The new hydraulic oil must be filtered before it enters the hydraulic oil reservoir. Keep the oil level of the hydraulic oil reservoir, at the correct level. An air space is designed into the hydraulic oil reservoir and allows for oil expansion, at warm temperatures. The hydraulic oil reservoir will have a low pressure in it at system operating temperatures.

NOTE: Located at side of charge filter is a cap on a number 10 JIC fitting (see Figure 4-8). This cap can be removed and hydraulic oil can be pumped in with a pump to get proper oil level.

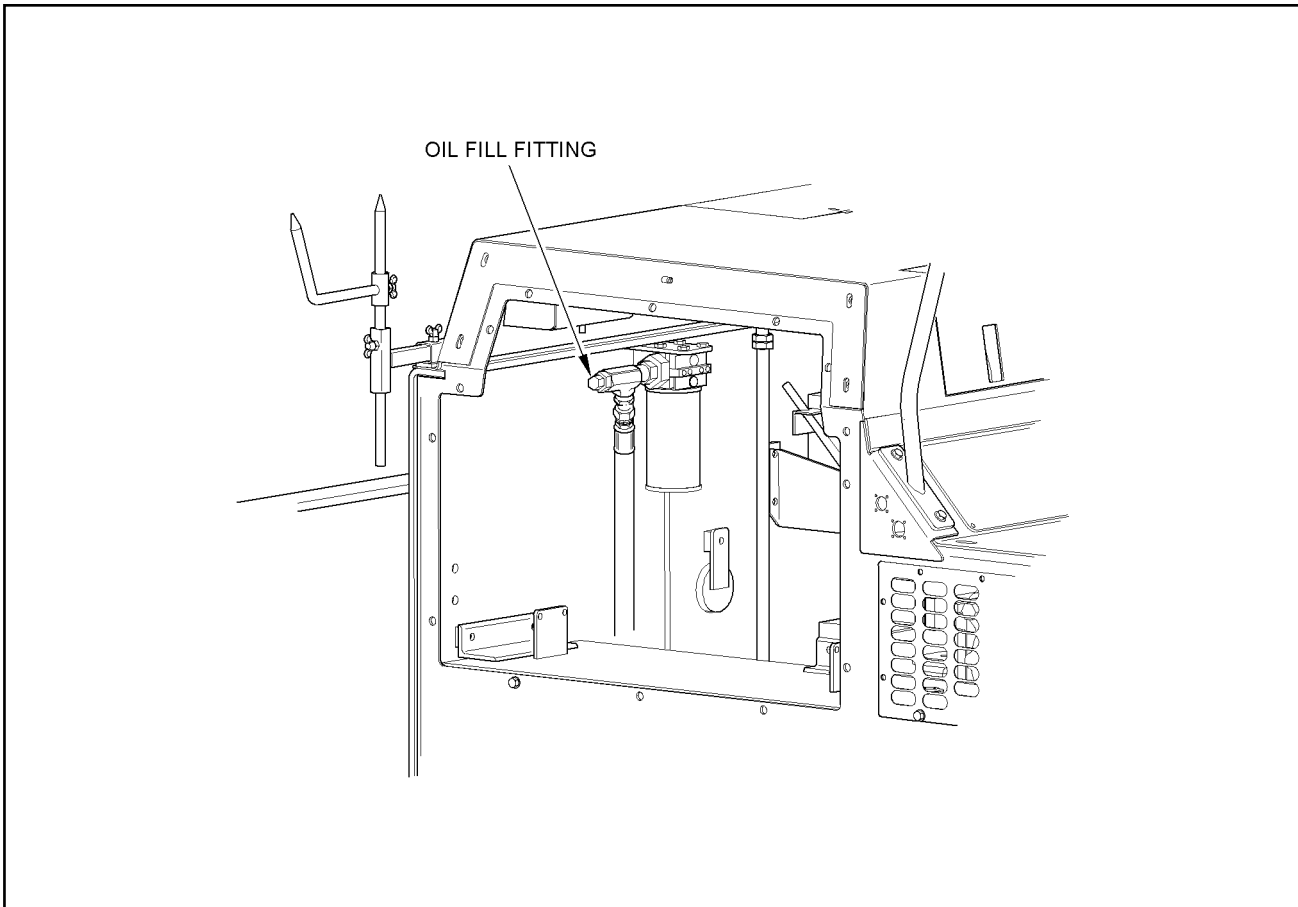



FIGURE. 4-11 OIL FILL FITTING ON CHARGE FILTER

Changing the Hydraulic Oil

Changing the hydraulic oil removes the accumulation of dirt, water and mechanical wear particles from the hydraulic oil reservoir and system. The chemical structure of the hydraulic oil also changes after continuous use in the system and new, clean, and filtered oil is a must to help insure further correct operation of the hydraulic system.

 **CAUTION:** Hydraulic oil which has oxidized or which contains contamination, of any type, can shorten the expected service life of any, or all, of the components in the hydraulic system.

Use the following procedures to change the hydraulic oil in the hydraulic oil tank (see Figure 4-9).

1. Stop the engine. Allow the hydraulic oil to cool, until it is at a warm temperature only. Slowly loosen, and then remove, the hydraulic oil reservoir filler cap (2). Put a CLEAN, lint free cloth over the reservoir fill tube opening and secure in place with tape.

 **WARNING:** Do not drain the hydraulic oil from the reservoir when it is "HOT". Hot hydraulic oil can cause serious injury. Drain at a warm temperature only.

2. Carefully remove the drain plug from the hydraulic tank. Use a drain collection device, of sufficient capacity to collect the hydraulic oil. Allow all of the hydraulic oil to drain from the reservoir and into the container.

 **CAUTION:** Do not fill the hydraulic oil reservoir with new hydraulic oil until the strainer has been serviced.

3. Install the hydraulic oil reservoir drain plug, and tighten securely.
4. Carefully remove the cloth from the hydraulic oil reservoir fill tube opening.
5. Remove the strainer on the tank.
6. Fill hydraulic oil tank with the correct, filtered hydraulic oil until tank is full.

CAUTION: Do not overfill the hydraulic oil reservoir with oil.



NOTE: Cold oil level should be about ½" to ¾" below full level on sight gauge.

CAUTION: Never let tank run dry. Pump damage will occur.



7. Install the hydraulic oil reservoir filler cap onto the reservoir filler neck and tighten securely.
8. Start the engine using the correct procedures given in Section 3 - OPERATION of this manual. Check the hydraulic system for any leaks.

WARNING: Do not use the hands on any hydraulic hose, fitting or system component to check the system for possible leaks. Serious injury can result from an oil leak under high pressure. Oil can be injected under the skin by high pressure. Protect the eyes by wearing safety glasses.



CAUTION: Stop the engine immediately if any hydraulic leak is noted. Do not start the engine until any problem noted has been corrected.



Changing the Hydraulic Oil Return Filter Element

The oil strainer is mounted in the oil filler opening under the filler cap.

 **WARNING:** Do not REMOVE the hydraulic oil CAP from the reservoir when it is "HOT". Hot hydraulic oil can cause serious injury. Allow hydraulic oil to cool down to a warm temperature.

1. Remove the hydraulic oil filler cap (2).
2. Remove the three screws securing the element, then remove the element.
3. Install the new element, Place the spring in the head.
4. Fill the hydraulic oil reservoir with the correct, filtered hydraulic oil until proper level is in sight gauge before fill cover is placed on.

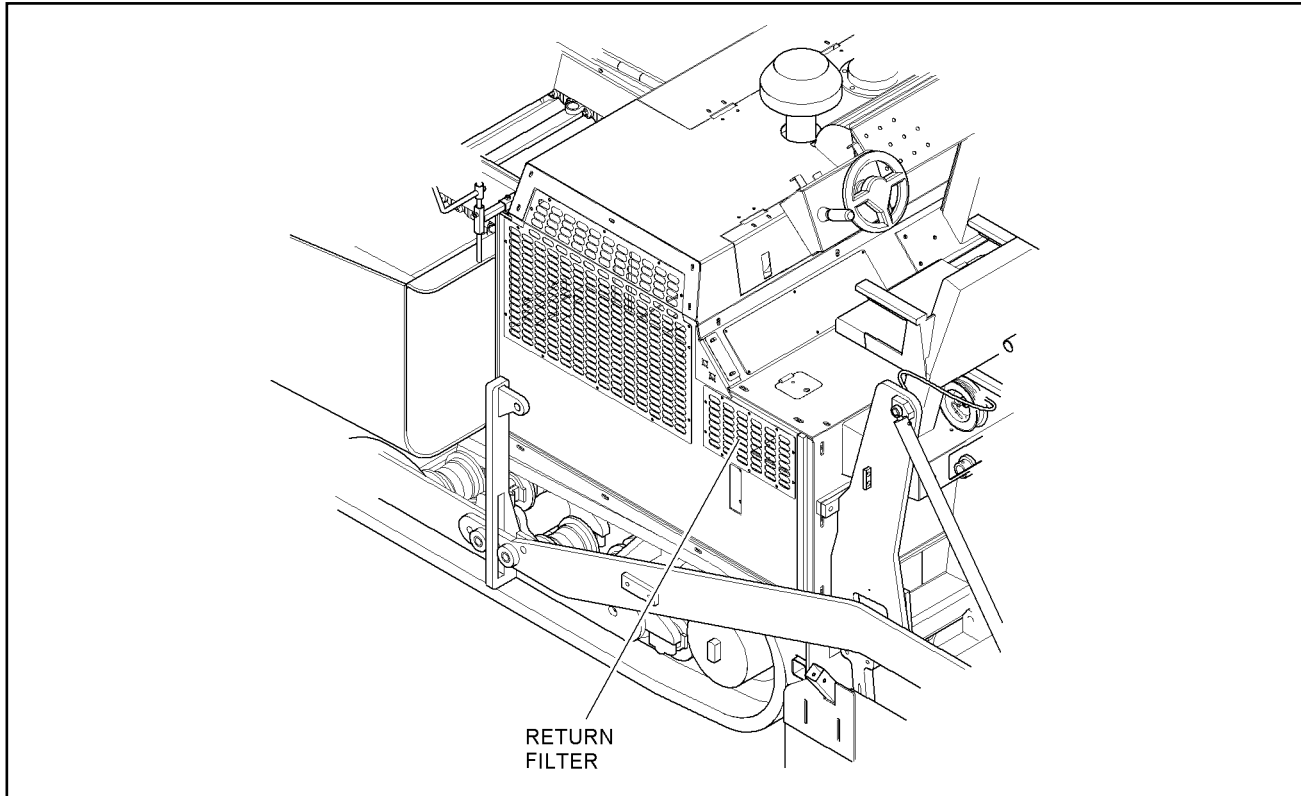

FIGURE 4-12 HYDRAULIC OIL TANK

Note: On earlier models, return filter cap is screwed on.

CAUTION: Do not overfill the hydraulic oil reservoir with oil.



5. Check the oil level in the hydraulic oil reservoir, again. Add oil if needed.
6. Install the hydraulic oil reservoir filler cap onto the reservoir filler neck and tighten securely.

REMOVAL AND INSTALLATION PROCEDURES

REPLACING 2-SPEED MOTOR

Removal

1. Drive machine on to ramp to access underside.
2. Label and disconnect all hydraulic hoses. Plug and cap fittings.
3. Remove two bolts holding motor to torque hub.
4. Slide motor out of torque hub.

Installation

1. Lubricate O-ring and install on motor.
2. Slide motor into torque hub.
3. Attach motor to torque hub with two bolts. Torque bolts to 120 ft. lbs. (311 N.m).
4. Clean all hoses and fitting and reconnect hoses.
5. Fill oil tank through the charge filter fill port. This will charge motor back with oil.
6. Start engine and let run for about 10 minutes before moving the machine. This will prevent damage to the new motor due to a dry start.
7. After completing installation, check hydraulic oil level.

REPLACING DRIVE TORQUE HUB

Removal

1. Drive machine on to ramp in order to access underside.
2. Remove track master pin at bottom rear of sprocket. Release track tension by screwing relief cartridge out of manifold about three turns. Drive machine forward to disconnect track from the top of the sprocket.

3. Follow directions for removing 2-speed drive motor.
4. Jack machine sprocket up out of track for removal.
5. Remove bolts holding sprocket on.
6. Slide sprocket off out of the way.
7. Use a hoist to hold torque hub from falling.
8. Remove bolts from rear of torque hub. Slide torque hub out with hoist.

Installation

1. Use hoist to place torque hub back to frame.
2. Place loctite on bolts and install bolts for holding torque hub in place. Torque bolts to 180 ft. lbs. (244 N.m).
3. Slide sprocket on to torque hub.
4. Place loctite on bolts and install bolts holding sprocket on. Torque bolts to 180 ft. lbs. (244 N.m).
5. Follow directions on installing 2-speed drive motor.
6. Lower machine so that sprocket goes back into track chain. Drive machine forward to rotate track onto top of the sprocket.
7. Place master pin back in track. (Loctite bolt.)
8. Tighten relief cartridge in manifold.

NOTE: Rotate torque hub so that the fill plug is at 12 o'clock and one of the oil level plugs is at 3 o'clock or 9 o'clock.

9. Fill torque hub with 90 WT gear oil. Oil level is to center of torque hub.

REPLACING TRACK SPROCKET

Removal

1. Rotate track master pin to bottom of sprocket.
2. Release track tension by screwing relief cartridge out of manifold about three turns.
3. Remove track master pin at bottom rear of sprocket. Drive machine forward to disconnect track from the top of the sprocket.
4. Jack machine sprocket up out of track for removal.
5. Remove bolts holding sprocket.
6. Slide sprocket off and replace.

Installation

1. Slide sprocket back in place.
2. Place loctite on bolts and install bolts holding sprocket.
3. Lower machine so that sprocket goes back into track chain. Drive machine forward to rotate track onto top of the sprocket.
4. Place master pin back in track and loctite bolts.
5. Tighten relief cartridge in manifold.

REPLACING FRONT IDLER OR BUSHING

Removal

NOTE: Idler can be removed without taking the track apart. Use comalongs to hold the track forward. Remove tension cylinder top guide and removed idler.

1. Rotate track so that master pin is at rear bottom of front idler.
2. Loosen track by screwing tension relief cartridge out about three turns.
3. Remove master pin.
4. Back machine up so that track does not lay on idler.
5. Remove complete idler by removing top guide on slide and disconnect cylinder.
6. Lift idler out and replace or install new bushing.

NOTE: Rebuild of bushing and seals can be done without taking idler off machine.

7. Remove hub cap at end and slide idler wheel off. Repair and reinstall.

Installing Front Idler After Replacing Bushings

1. Slide idler wheel back on to idler shaft.
2. Place hub cap back on by using a bolt screwed into idler axle to act like a press. Align roll pin hole in cap and axle.
3. Drive roll pin in.
4. Fill with 90 WT gear oil.
5. Place master pin back in track.
6. Tighten track tension relief cartridge.

Section 4

MAINTENANCE



Installing New Front Idler

1. Place new idler with slide block back in bottom guide.
2. Lubricate slide.
3. Place top guide against idler slide snug. Snug bolts then tap guide down. Once snug, torque bolts to 180 ft. lbs. (244 N.m).
4. Connect cylinder.
5. Place master pin back in track.
6. Tighten track tension relief cartridge.

ADJUSTING TRACK TENSION

1. Locate main electrical valve, left side of machine, remove slotted cover.

NOTE: Tension manifold is located at screed end of electrical valve.

NOTE: The following adjustment should only be performed if track jumps in reverse.

2. Tension is adjusted to 900 PSI. If adjustment is needed, adjust pressure-reducing valve, located on side toward screed. Screw in for more tension and out for less tension. Too much pressure will cause premature wear on the chains, idler and sprockets.

CAUTION: Do not screw out below the 900 PSI or all pressure will be lost to tank, causing a heat problem.



3. Relieving pressure is set to 1500 PSI. This adjustment is located on side of tension manifold toward outside of left side. If adjustment is needed, screw in for more pressure and out for less. If track jumps in reverse, adjust relieving pressure.

REPLACING REAR CONVEYOR SHAFT, BEARINGS, AND SPROCKETS

Removal

1. Place machine over a pit or on a ramp.
2. Disconnect main conveyor chains underneath the equipment. Disconnect any link. Rotate chains out of the way of the assembly.
3. Remove chain from torque hub to conveyor sprocket.
4. Remove track pads at rear of sprocket, so that sprocket will slide off.

5. Remove bolt and washers holding sprocket on.
6. Remove sprocket and bearing from frame side.
7. Remove inner snap ring at inner sprocket. (Later models have bolts)
8. Shaft and outer conveyor sprocket should slide out through frame side.

NOTE: Rear tube can be removed for changing inner bearings.

NOTE: Replaced bearings in tubes must have inner seals removed so that grease can enter into the bearing area from grease fitting.

9. Replace bad or damaged parts.

Installation

1. Place conveyor shaft into inner conveyor sprocket.
2. Place snap ring on shaft. (Later models have bolts)

NOTE: Outer conveyor sprocket must be aligned with inner sprocket.

3. Rotate outer sprocket on shaft until properly aligned.
4. Reinstall outer bearing and outer sprocket.
5. Locktite bolt and torque to 180 ft. lbs. (244 N.m).
6. Place conveyor and drive chains back on and adjust.
7. Grease bearings by removing plugs in tubes and place grease fitting in tubes, then grease. Fitting applies grease in between two bearings on each side. When finished, remove fittings and reinstall plugs in tubes.

REPLACING FRONT CONVEYOR SHAFT, BEARINGS, AND SPROCKETS

Removal

1. Place machine over a pit or on a ramp.
2. Disconnect main conveyor chains underneath the equipment. Disconnect any link. Rotate chains out of the way of the assembly.
3. Loosen idler adjust bolts and remove hold down bolts. Assembly will come out at this time.

4. Remove damaged or worn parts and reinstall.

NOTE: Replaced bearings in tubes must have inner seals removed so that grease can enter into the bearing area from grease fitting.

Installation

1. Reverse removal procedure and place back in machine.
2. Connect main conveyor chains and adjust tension. Make sure all hold down bolts are torqued to 180 ft. lbs. (244 N.m). Tighten jam nuts on adjuster bolts.
3. Grease bearings by removing plugs in tubes and place grease fitting in tubes, then grease. Fitting applies grease in between two bearings on each side. When finished, remove fittings and reinstall plugs in tubes.

REPLACING CONVEYOR WEAR PLATE

Removal

1. Place machine over a pit or on a ramp.
2. Remove all guards over conveyor floor and front lip panel.
3. Remove main conveyor chains from machine.
4. Remove front conveyor idlers from machine.
5. Remove bolts from rear tube assemblies and let assembly be held only by outer bearing.
6. Remove 16 bolts that holds floor into frame.
7. Lift wear plate out of machine with hoist.

Installation

1. Clean frame where conveyor plate lays.
2. Place new conveyor plate in frame.
3. Loctite the sixteen 5/8" bolts and tighten conveyor plate to frame. Torque bolts to 180 ft. lbs. (244 N.m).
4. Place rear drive assembly back in place.
5. Loctite bolts and torque to 180 ft. lbs. (244 N.m).
6. Tighten adjuster against assembly to keep from slipping.
7. Place front idler assemblies back in place.

8. Place main conveyor chains in and adjust chain tension. Once adjusted, torque all idler hold down bolts to 180 ft. lbs. (244 N.m).
9. Adjust tension bolts tight against assembly when done and lock jam nuts.
10. Place all guards over conveyor chains and front lip panel.
11. Grease bearings (idler and drive tubes) by removing plugs in tubes. Place grease fitting in tubes, then grease. Fittings applies grease in between two bearings on each side. When finished put plugs back in tubes.

NOTE: Replaced bearings in tubes must have inner seals removed so that grease can enter into the bearing area from grease fitting.

REPLACING CONVEYOR DRIVE MOTOR

Removal

1. Remove hydraulic hoses from motor.
2. Remove two bolts holding hydraulic motor in torque hub.
3. Slide drive motor out of torque hub.

Installation

1. Check O-ring on new or repaired drive motor. Lubricate O-ring before installing.
2. Slide new or repaired drive motor into torque hub.
3. Secure with two bolts.
4. Reconnect hydraulic hoses to motor.
5. Check for leaks.

REPLACING CONVEYOR TORQUE HUB

Removal

1. Remove hydraulic hoses from motor.
2. Remove two bolts holding hydraulic motor in torque hub.
3. Slide drive motor out of torque hub.
4. Loosen adjusting bolts on torque hub slide.
5. Disconnect chain from torque hub to conveyor drive sprocket.
6. Slide torque hub up and out.

Section 4

MAINTENANCE



7. Remove sprocket mounted on torque hub.
8. Remove bolts in slide mount to remove from torque hub.

Installation

1. Replace or repair torque hub.
2. Place slide mount back on torque hub.
3. Loctite bolts and tighten.
4. Grease splines before installing sprocket.
5. Slide sprocket back on to torque hub shaft.
6. Loctite and tighten bolt holding sprocket.
7. Grease slide then slide torque hub back into slide holders.
8. Place chain back on sprocket and adjust for ¼" slack.
9. Check O-ring on new or repaired drive motor. Lubricate O-ring before installing.
10. Slide new or repaired drive motor into torque hub.
11. Secure with two bolts.
12. Reconnect hydraulic hoses to motor.
13. Fill torque hub with 90 wt. gear oil. Fill through top plug until oil runs out of plug at 3 o'clock or 9 o'clock position. Once filled reinstall seal plugs and tighten.
14. Check for leaks.

REPLACING CUTOFF ASSEMBLY

Removal

1. Remove stub shaft sliding into outer end of auger tube assembly by removing the last bolt holding auger sections.
2. Remove auger end mount holder by removing the four top bolts.
3. Remove two inner auger section bolts.
4. Disconnect cutoff cylinder cutoff and auger assembly will slide off of inner drive shaft for replacement.

NOTE: If inner cutoff pivot mount (with 4 bolts) is ok, auger assembly does not need to come out. Just remove outer stub shaft, cylinder, and 4 inner pivot mount bolts, holding cutoff on, and remove cutoff.

Installation

1. Clean area at auger cover where inner pivot rotates.
2. Grease and slide inner cutoff pivot mount back on. Slide auger assembly onto inner drive shaft and place bolts through auger sections with teflon washers between sections and auger tube.
3. Bolt auger end mount back on with four ½" bolts.
4. Grease bushing inside and on side where cutoff pivots.
5. Slide outer stub shaft back in.
6. Slide new cutoff on to outer bushing and start 4 bolts at inner pivot.
7. Connect cylinder back to cutoff.
8. Close cylinder hydraulically until cutoff assembly closes shut against frame.
9. Tighten 4 inner bolts in cutoff to hold in place.

REPLACING INNER AUGER DRIVE SHAFT

Removal

1. Remove stub shaft sliding into outer end of auger tube assembly by removing the last bolt holding auger sections.
2. Remove auger end mount holder by removing the four top bolts.
3. Remove two inner auger section bolts.
4. Disconnect cutoff cylinder, cutoff and auger assembly will slide off of inner drive shaft.
5. Remove auger cover that covers chains.
6. Disconnect chains by loosening adjuster that pushes up on auger motor slide and the horizontal adjuster pushing in on slide.
7. Remove trunion cap at bottom of auger bearing. This will let inner drive shaft or bearing to be replaced.

Installation

1. Place new shaft with sprocket or bearing back in machine. Torque trunion cap to 40-50 ft-lbs.

NOTE: If trunion clamp is too tight, bearing will fail.

2. Clean area at auger cover where inner pivot rotates.

- Grease and slide inner cutoff pivot mount back on machine.
- Slide auger assembly on inner drive shaft and place bolts through auger sections with teflon washers between section and auger tube.
- Bolt auger end mount back on with four 1/2" bolts.
- Grease bushing inside and on side where cutoff pivots.
- Slide cutoff on to outer bushing and start 4 bolts at inner pivot.
- Place stub shaft back into outer end of auger tube using the one auger section bolt.
- Connect cylinder back to cutoff.
- Close cylinder hydraulically until cutoff assembly closes shut against frame.
- Tighten inner 4 bolts in cutoff to hold in place.
- Place chains back on and adjust for 1/4" slack in chain.
- Before installing covers spray chains well with chain lube.

WARNING: Do not allow hands or clothing near chain or auger while engine is running.



- Slotted area in top of auger cover is there for spraying through top to lubricate chains while augers are rotating.

REPLACING AUGER MOTOR

Removal

- Remove covers over chains.
- Loosen auger motor and remove chain.
- Label and disconnect hydraulic hoses and plug fittings.
- Auger motor mount with motor will slide up and out of slide holder for motor replacement or repair.
- Slide sprocket off and remove mount.

Installation

- Place auger motor mount and sprocket on to motor.
- Place loctite on bolts and tighten.

- Connect chain, adjust for 1/4" slack in chain and lubricate with chain lube.
- Connect hydraulic hoses and check for leaks.

NOTE: If auger bypass manifold was removed, when reinstalling, use small amount of grease to hold O-rings in grooves. Slide bolts through mounting holes and start in threads of motor before touching manifold to motor. This will eliminate O-ring damage.

REMOVING REAR HOPPER WING CYLINDERS

Removal

- Fold hopper wing all the way in.
- Prop wing closed so that wing will not fall open after cylinder is disconnected.
- Open front cover on hood to access round cover at bolt location at rod end of cylinder.
- Remove top bolt through opening.
- Fold cylinder out and disconnect hoses.
- Disconnect mount at blind end of cylinder and slide cylinder off.

Installation

- Slide cylinder on bottom mount.
- Loctite bolts and attach cylinder to mount.
- Clean hydraulic hoses and connect to cylinder.
- Extend cylinder so that bolt in rod end lines up with mount.
- Loctite bolt and tighten.
- Attach round cover in hole with bolt and close hood.

REPLACING HOOD, PUMPS, AND DOUBLE PUMP DRIVE

Removing Hood

- Remove muffler.
- Disconnect air breather boot from turbo.
- Disconnect hose from blower to chrome stack.
- Loosen jam nuts on front bolts and remove front, rear, and side bolts attaching hood.
- Unplug front work lights and beacon.
- Remove bracket from dash to hood.

Section 4

MAINTENANCE



7. Remove chrome stack and attach lift chains to D rings to lift hood.

Removing Pumps

1. Turn all valves off on hydraulic tank.
2. Tag and disconnect hydraulic hoses on pumps that are to be removed.
3. Rear piggyback pumps must be removed before main drive or conveyor pump can be removed from pump drive.
4. Disconnect wires at EDC's if removing drive or conveyor pumps.

WARNING: Pumps and pump drive are very heavy. Use hoist to lift pumps or pump drive.



5. Attach hoist to pump being removed.
6. Remove bolts holding main pumps to pump drive and slide out faulty pump.

Removing Pump Drive

1. Attach hoist to pump drive.
2. After all pumps have been removed, remove 12 bolts that hold pump drive to engine.

WARNING: Pump drive is very heavy. Use hoist to lift drive.



3. Slide pump drive out of splined coupling on engine.

Removing Inner Drive Coupling

1. Any time pump drive is removed, check drive coupling for wear or damage.
2. Remove all bolts and pull coupling out of flywheel.

Installing Drive Coupling

1. Clean flywheel and threaded bolt holes with ether. This will provide a clean surface for loctite to seal.
2. Install new drive coupling in flywheel.
3. Loctite bolts and torque to specifications located in manual.
4. Insert grease in coupling splines and on pump drive splines.

Installing Pump Drive

1. Be sure splines are greased.
2. Slide pump drive into drive coupling.
3. Torque bolts to specifications in manual.

Installing Pumps

1. Grease splines on pump and pump drive.
2. Place O-rings or gaskets on pumps and slide pumps into pump drive.
3. Loctite and torque pump bolts to specifications in manual.
4. After installing pumps fill pump drive with 80W-90 Gear oil. Check level with dip stick.

Installing Piggyback Pumps

1. Check O-rings and place piggyback pumps into main pumps.
2. Torque bolts to specification in manual.
3. Connect all wires to proper locations as marked.
4. Be sure hoses and fittings are clean then reconnect all hoses.
5. When all hoses are connected, turn all valves back on.

NOTE: Before starting engine and checking for leaks, drive and conveyor pumps must be charged with oil to prevent damage from dry startup.

6. Fill oil tank through the charge filter fill port. This will charge pumps back with oil.

Installing Hood

1. Lift hood into position then bolt hood back onto machine.
2. Lock the front three bolts with the jam nuts.
3. Fasten brace between hood and dash.
4. Connect lights and beacon wires.
5. Connect air breather boot to turbo and tighten.
6. Bolt chrome stack to hood and connect blower hose.
7. Slide muffler back onto exhaust manifold.
8. Start engine and let run for about 10 minutes before moving the machine. This will prevent damage to the new pump due to a dry start.
9. After completing installation, check hydraulic oil level.

REPLACING SCREED EXTENSION WEARPLATES

Removal

1. Run extension out fully.
2. Remove endgate by disconnecting tilt screw and loosen lock on the 7/8" jam nut.
3. Remove jam nut. Endgate will drop forward out of slot and slide off of stud.
4. Remove bolts out of lower adjustment screws on top of wearplate.
5. Remove burner.
6. Lower screed to ground and pull front pivot pin out.
7. Lift screed and wearplate should be disconnected.

Installation

1. Clean all areas where new wearplate will be attached.
2. Place new wearplate in position with floor jack or by lowering screed to floor and slide pivot pin in.
3. Attach adjustment screws to new wearplate.
4. Connect burner.
5. Place endgate back on.
6. Adjust 7/8" nut so that endgate will move up and down freely, then lock in place with jam nut.
7. Connect tilt screw.

REPLACING SCREED MAIN WEARPLATES

Removal

1. Remove walkboards.
2. Remove screed lids.

NOTE: Once walkboards are removed lids will slide out.

3. Remove or torch the 20 bolts holding wearplate to screed frame.
4. Before raising screed off of wearplate, clamp center of crown gussets so that screed frame stays flat.
5. Raise screed off of wearplate.

Installation

1. Clean screed frame.
2. Set screed frame down on to new wearplate letting cylinders carry most of weight. This will let plate be moved for alignment of bolts.
3. Place 5 bolts in front left side first.
4. Rotate crown in and out so that five bolts in right side line up.

NOTE: May need to clamp or pry around to line up.

5. Once these bolts are in place, bolt rear of plate up to frame assembly.
6. Once bolts are started, lift screed and set on three 2" x 4" boards to hold flat. Place one board at each end and one in the center.
7. Let screed all the way down and torque bolts from center out, 2 on left side then 2 on right side until all bolts are torque to 80 ft. lbs. (N.m).
8. Install screed lids and walkboards.

AUGER CONVEYOR HEIGHT MIN/MAX PILE HEIGHT POD CALIBRATION

If the pile height knob is turned to "Full Max Pile Height" and Auger/Conveyor stops turning, then calibration of POD needs to be performed.

CALIBRATION PROCEDURE

1. Turn pile height knob to center position.
2. Crank engine and turn conveyor on at side needing to be recalibrated.
3. While conveyor is turning, unplug pile height POD at weather pack connector and plug back in. This tells micro to go to calibrate.
4. Turn pile height knob all the way counterclockwise for about 3 seconds, then turn fully clockwise for an additional 3 seconds. POD should be calibrated.
5. Test to make sure calibration is correct by turning POD all the way clockwise. If conveyor and Auger stays on, it is calibrated. If not recalibrate by performing steps 1 through 4.

Section 4 MAINTENANCE



SCHEMATICS

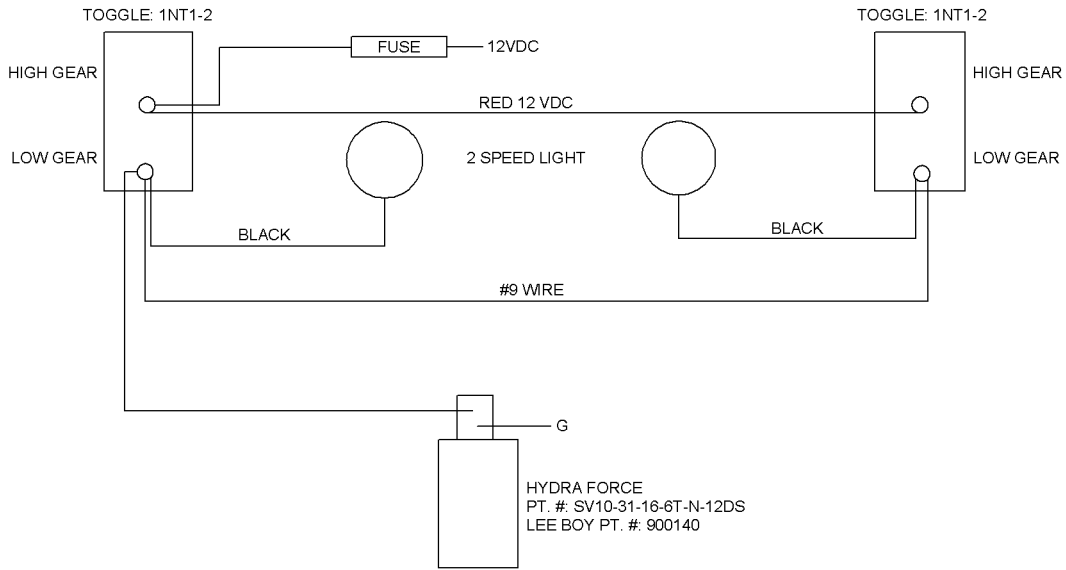

2-SPEED ELECTRICAL SCHEMATIC

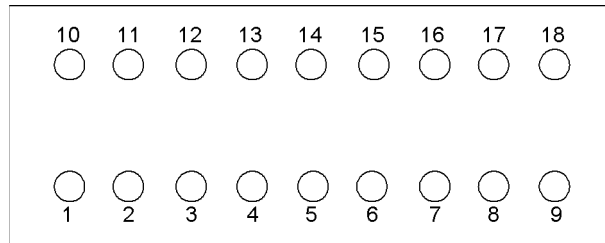

- 1 LEFT EXTENSION
- 2 LEFT CUTOFF
- 3 RIGHT CUTOFF
- 4 SIDEWINGS
- 5 RIGHT EXTENSION
- 6 LEFT CONVEYOR / AUGER MICRO
- 7 RIGHT CONVEYOR / AUGER MICRO
- 8 SCREED LIFT
- 9 2 SPEED
- 10 TOW POINT
- 11 THOTTLE
- 12 HORN / SPRAYDOWN
- 13 WORKLITES / BEACON
- 14 OPEN
- 15 LEFT AUGER / REVERSE
- 16 RIGHT AUGER / REVERSE
- 17 ELECTRONIC STEER
- 18 OPEN

8816 FUSE BLOCK

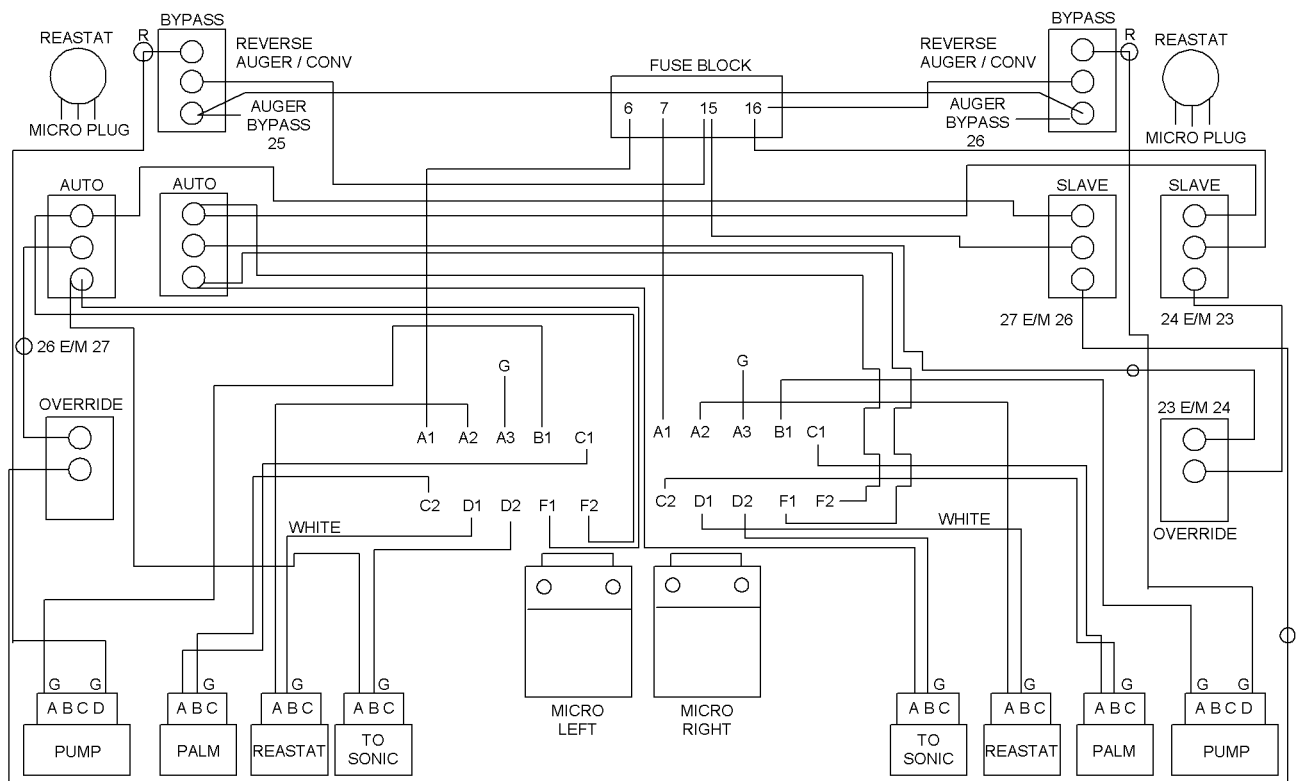

NOTE: R @ BYPASS SWITCH = RESISTOR 300 OHM

COMPLETE CONVEYOR ELECTRICAL SCHEMATIC

Section 4 MAINTENANCE

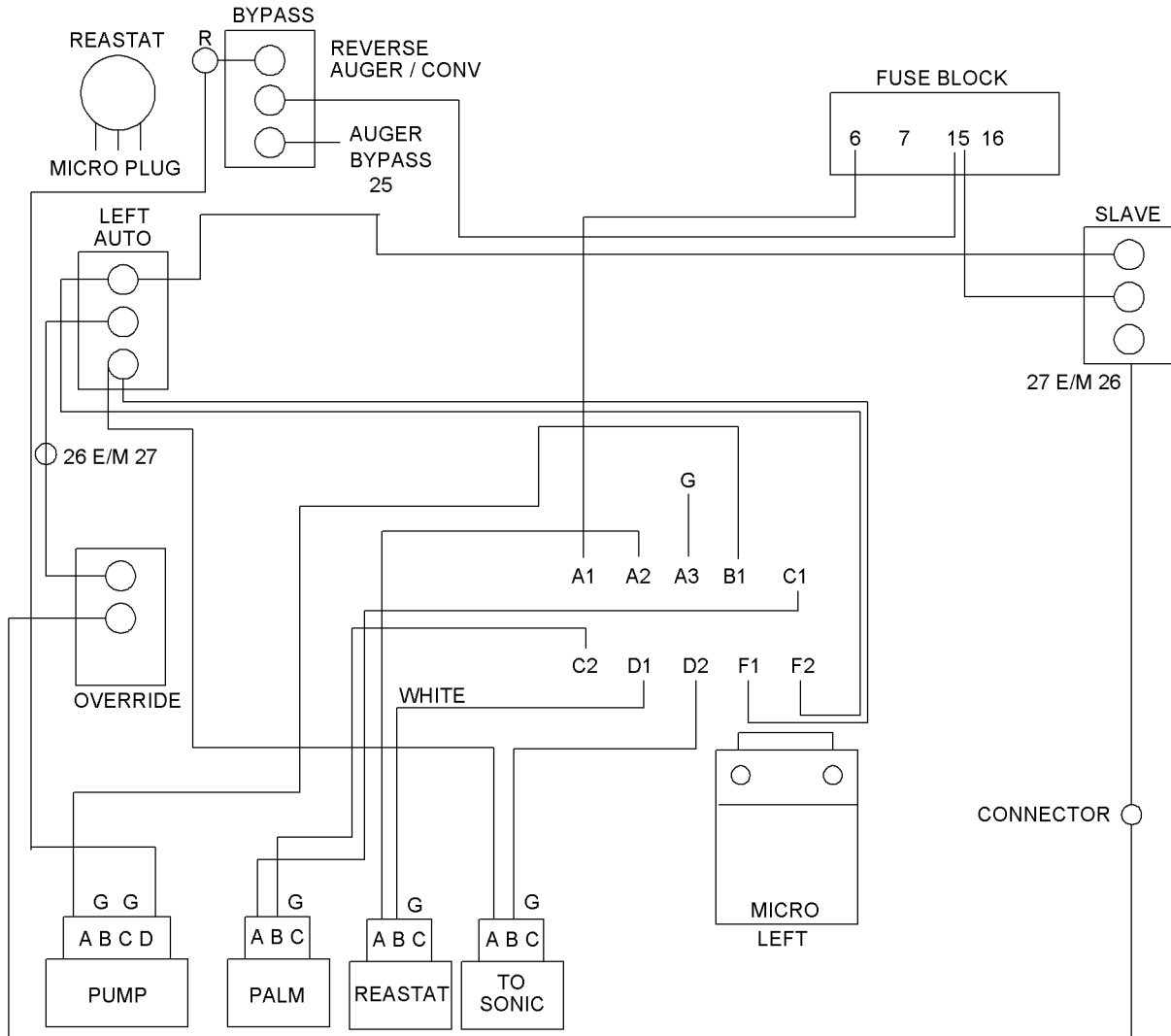

NOTE: E/M EARLIER MODELS
NOTE: R @ BYPASS SWITCH = RESISTOR 300 OHM

LEFT CONVEYOR ELECTRICAL SCHEMATIC

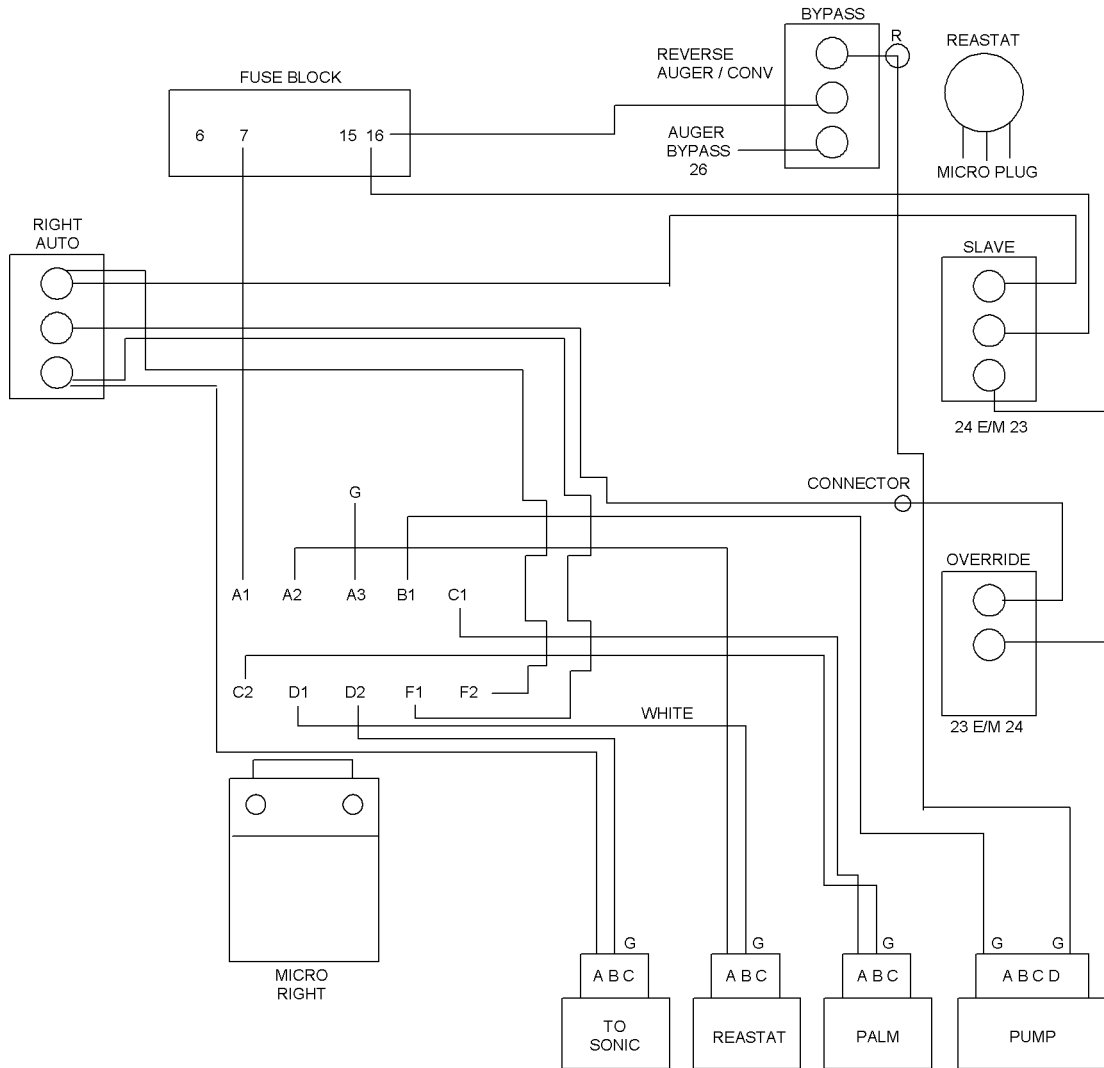

NOTE: R @ BYPASS SWITCH = RESISTOR 300 OHM

RIGHT CONVEYOR ELECTRICAL SCHEMATIC

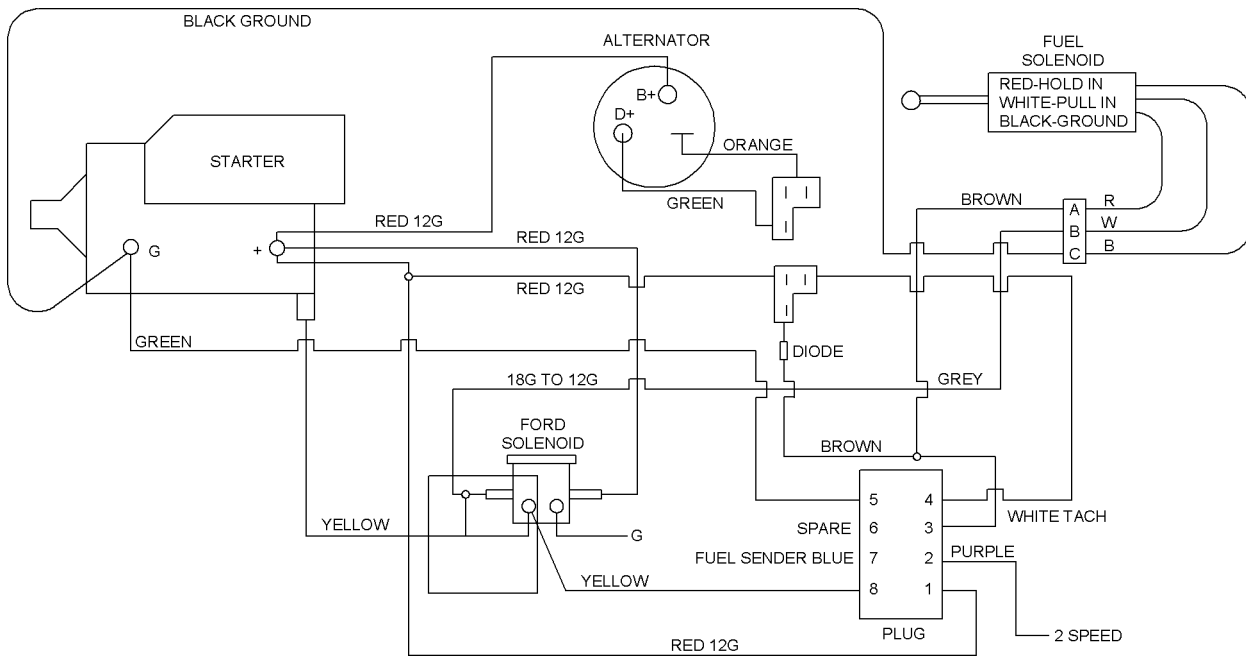

CUMMINGS ENGINE ELECTRICAL SCHEMATIC

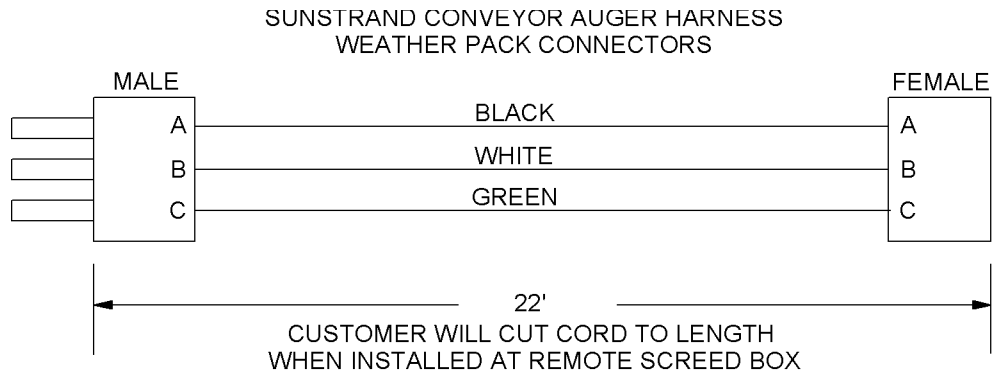

EXTENDED PILE HEIGHT HARNESS REMOTE BOX

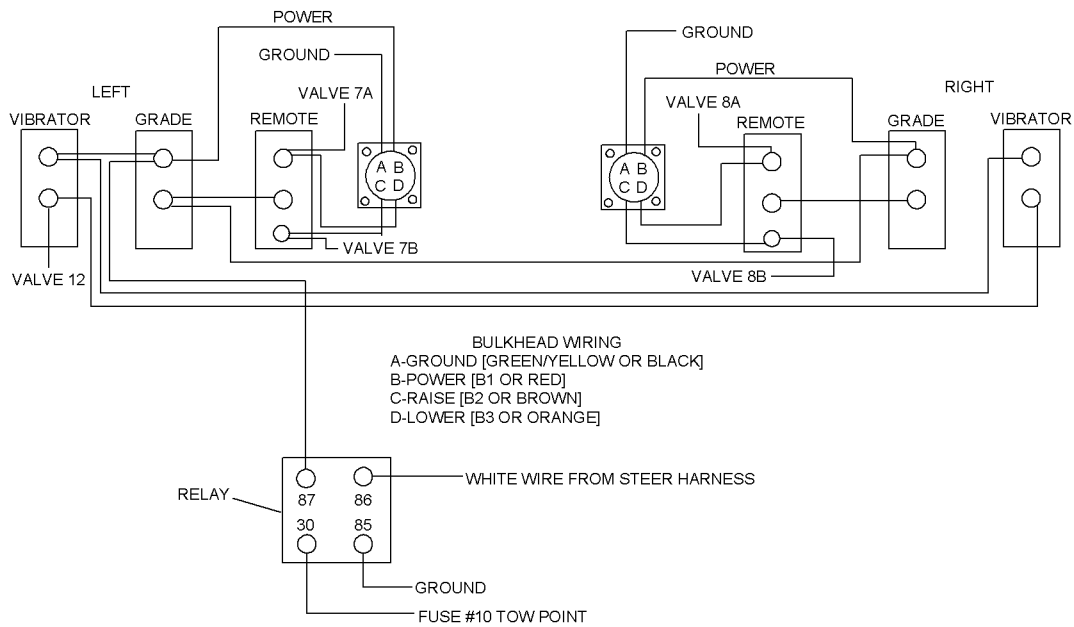

GRADE AND VIBRATOR RELAY ELECTRICAL SCHEMATIC

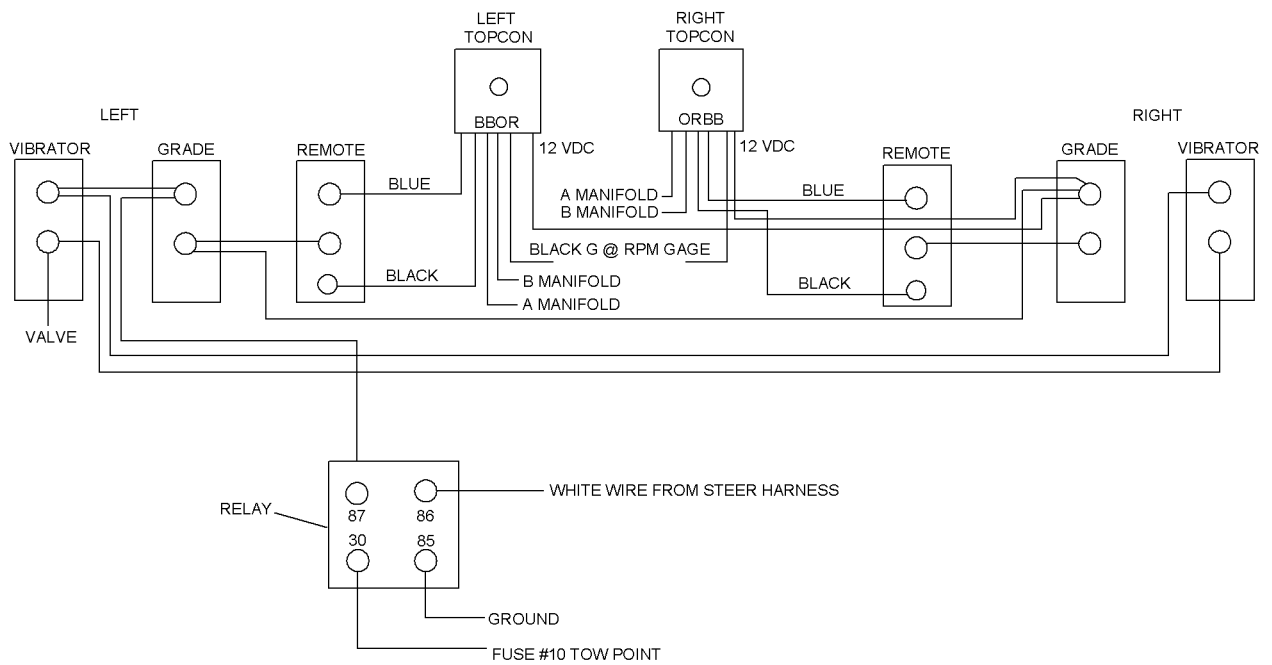

GRADE AND VIBRATOR RELAY TOPCON ELECTRICAL SCHEMATIC

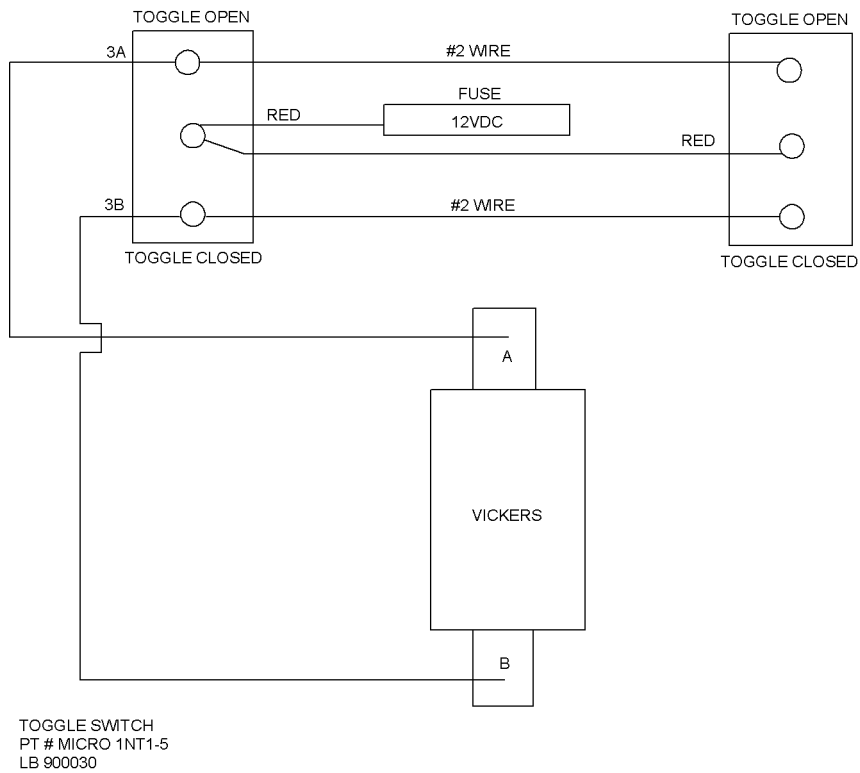

LEFT CUTOFF ELECTRICAL SCHEMATIC

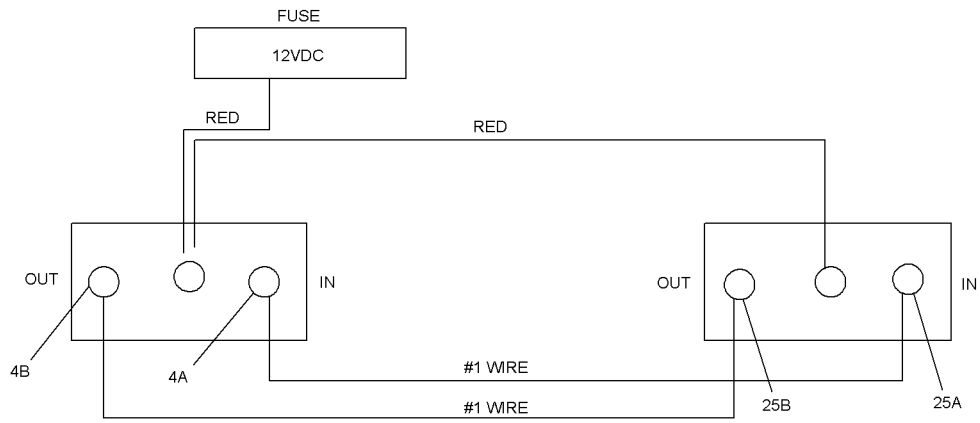

TOGGLE SWITCH
PT #. MICRO 1NT1-5
LB PT # 900030

LEFT EXTENSION SHOP ELECTRICAL SCHEMATIC

Section 4 MAINTENANCE

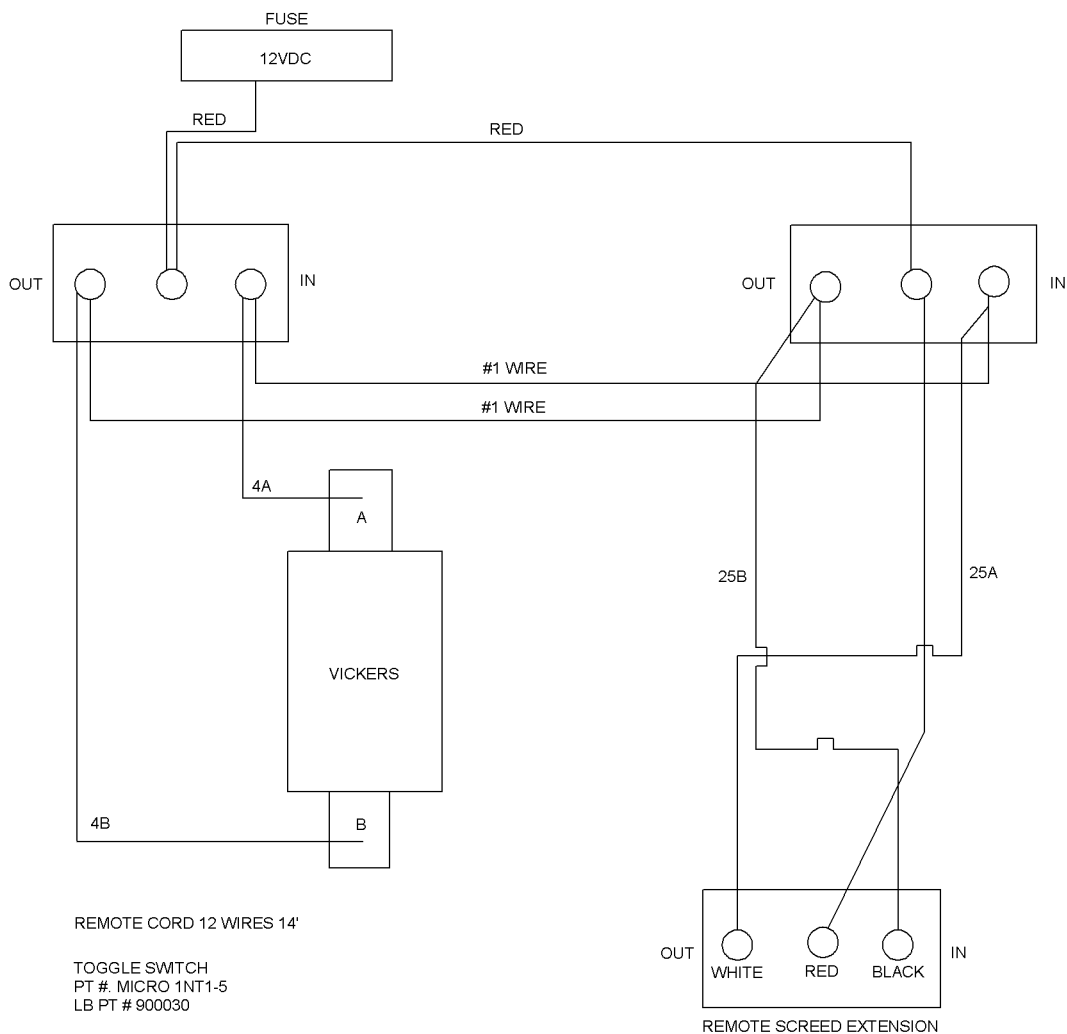

LEFT EXTENSION ELECTRICAL SCHEMATIC

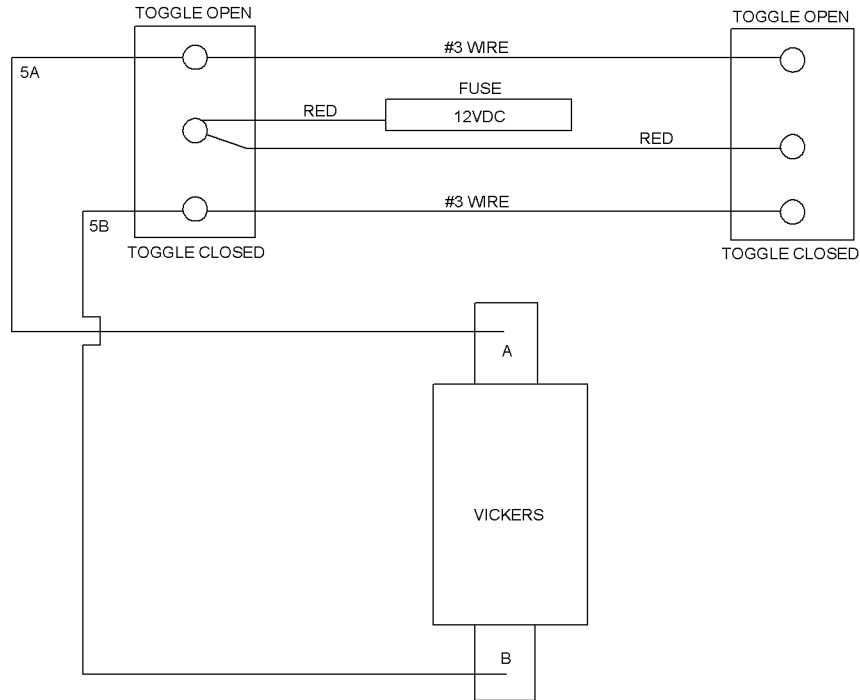

TOGGLE SWITCH
MICRO PT # 1NT1-7
LB #

RIGHT CUTOFF ELECTRICAL SCHEMATIC

Section 4 MAINTENANCE

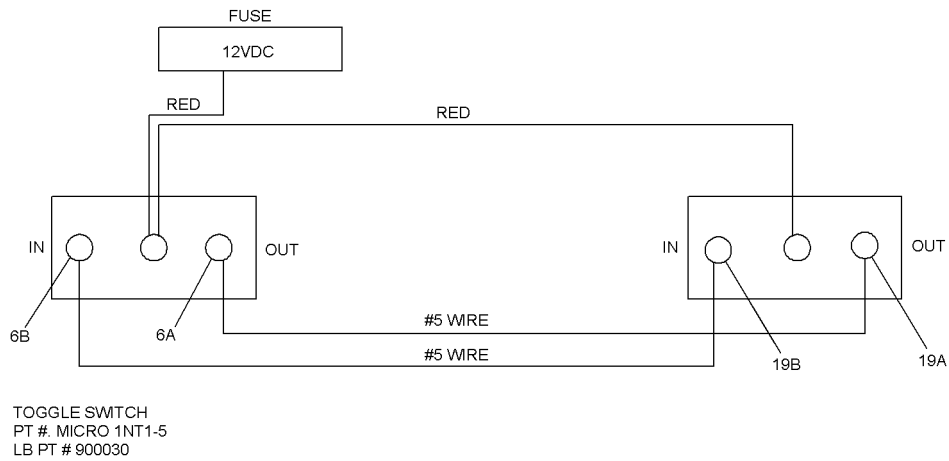

RIGHT EXTENSION SHOP ELECTRICAL SCHEMATIC

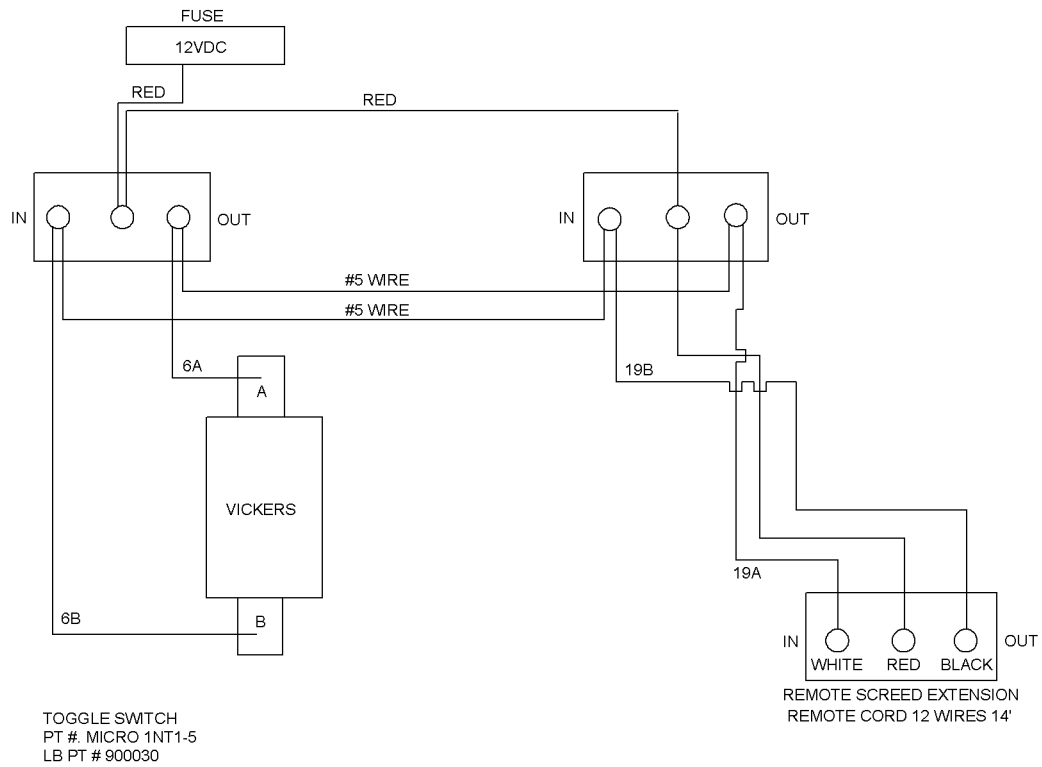

RIGHT EXTENSION ELECTRICAL SCHEMATIC

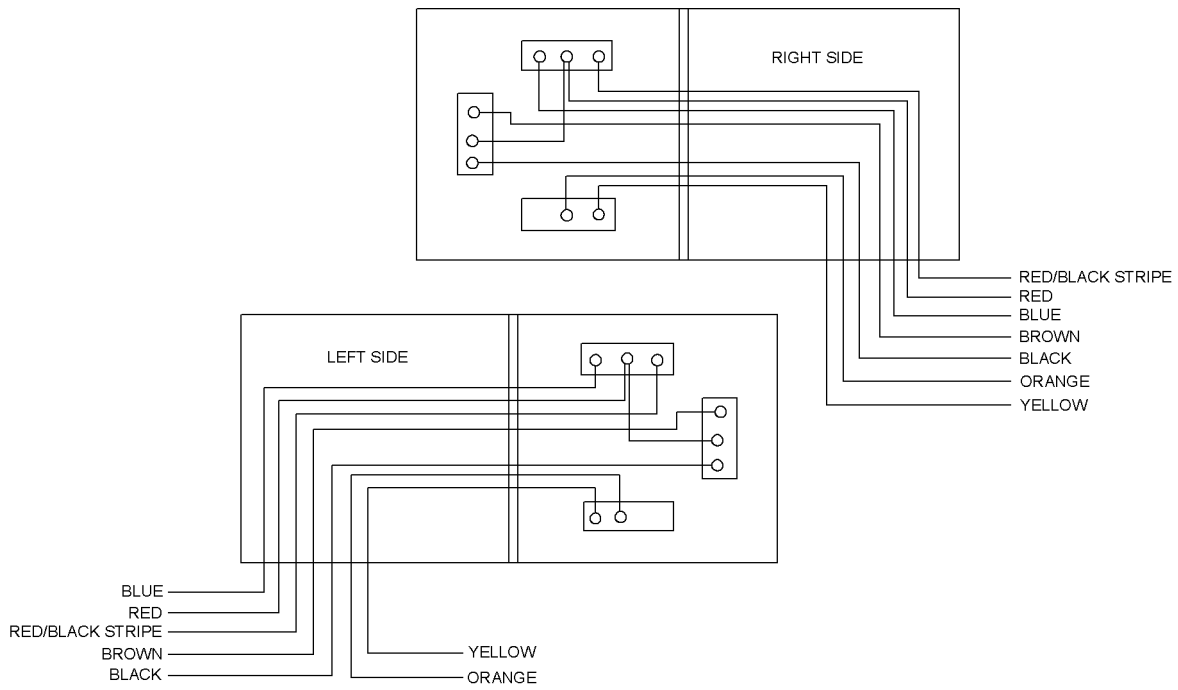

REMOTE SCREED BOX ELECTRICAL SCHEMATIC

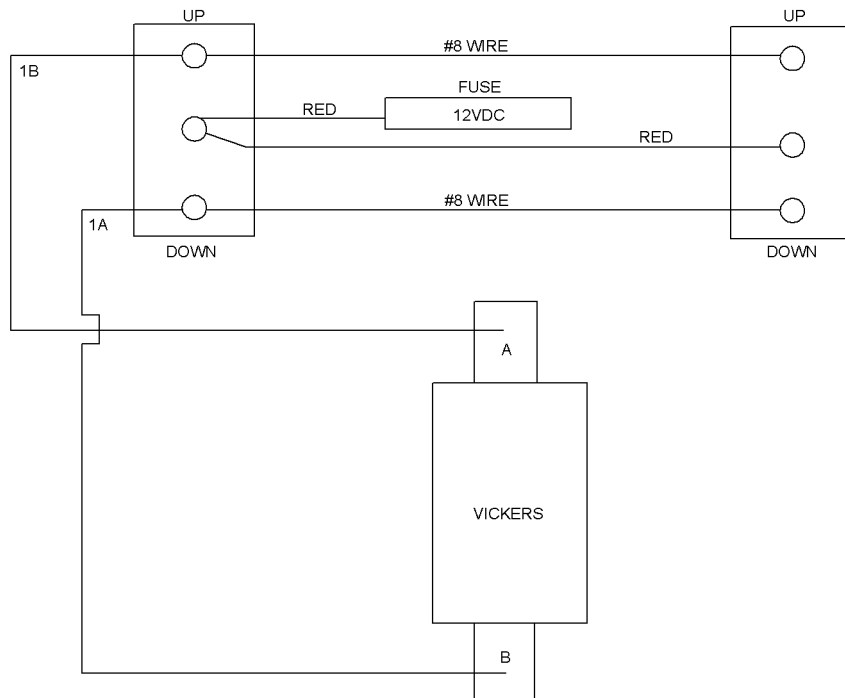

TOGGLE SWITCH
MICRO PT # 1NT1-7
LB #

SCREED LIFT ELECTRICAL SCHEMATIC

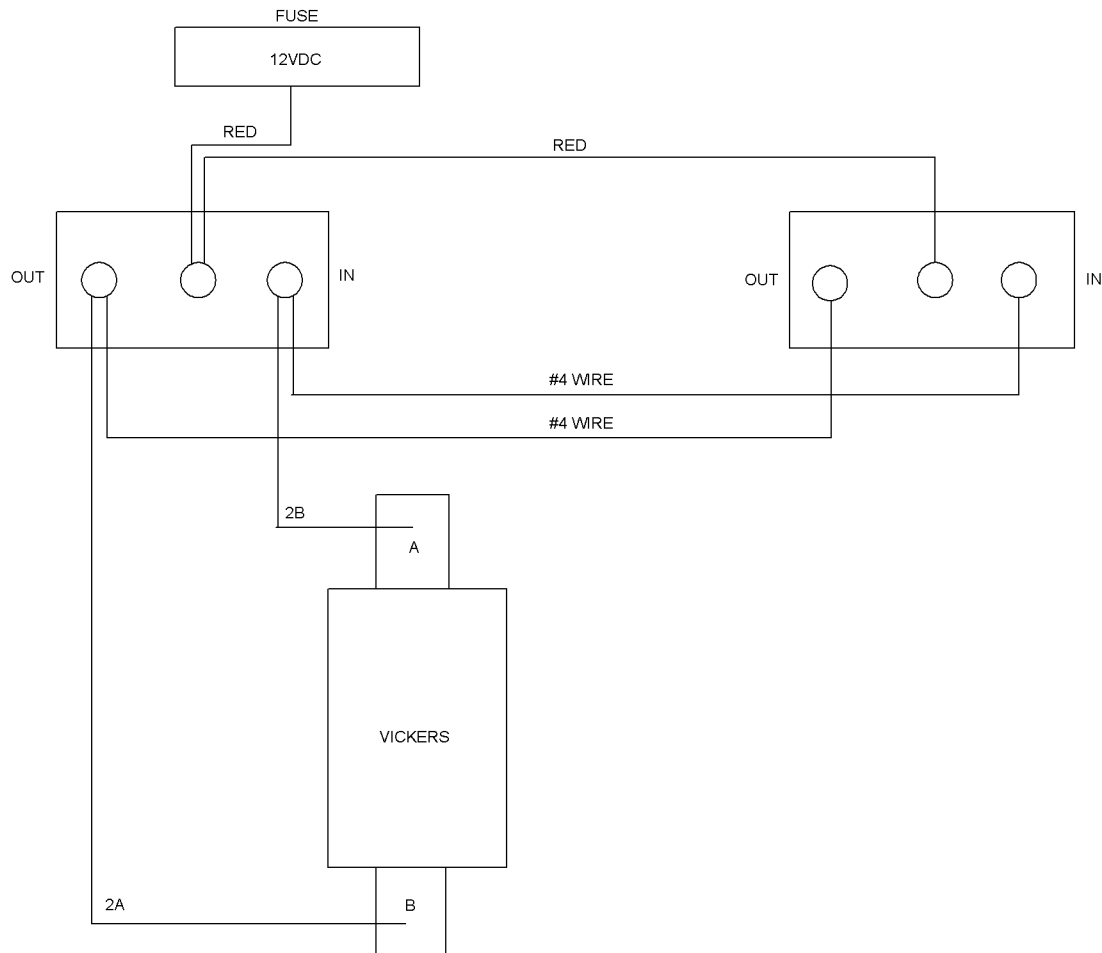

TOGGLE SWITCH
PT #. MICRO 1NT1-5
LB PT # 900030

SIDEWING ELECTRICAL SCHEMATIC

JUNCTION BOX PART #: 1090784
 SUNSTRAND HARNESS PART #:
 DATE: 5/16/02

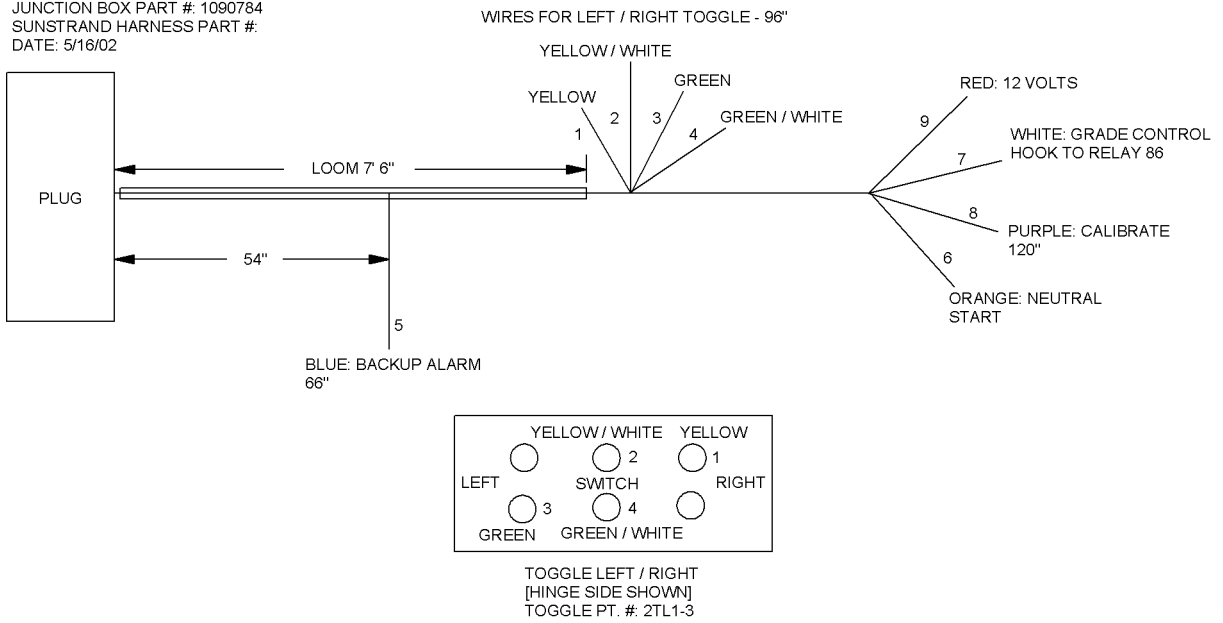

SUNSTRAND HARNESS ELECTRICAL SCHEMATIC

Section 4 MAINTENANCE

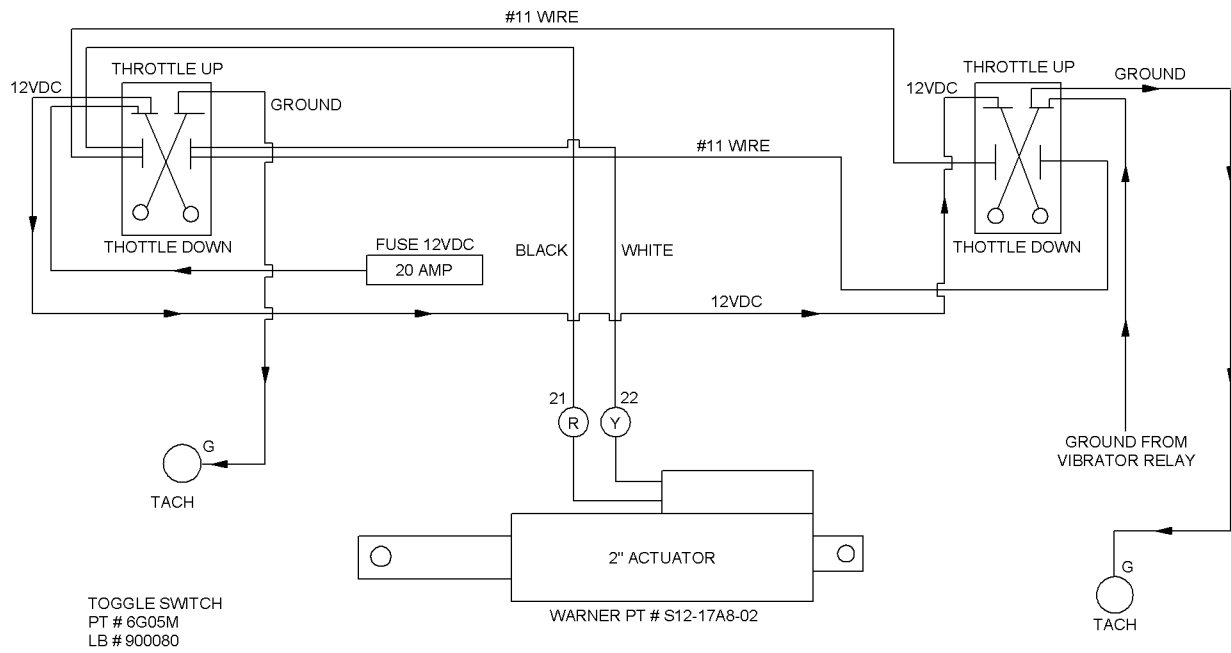

THROTTLE ELECTRICAL SCHEMATIC

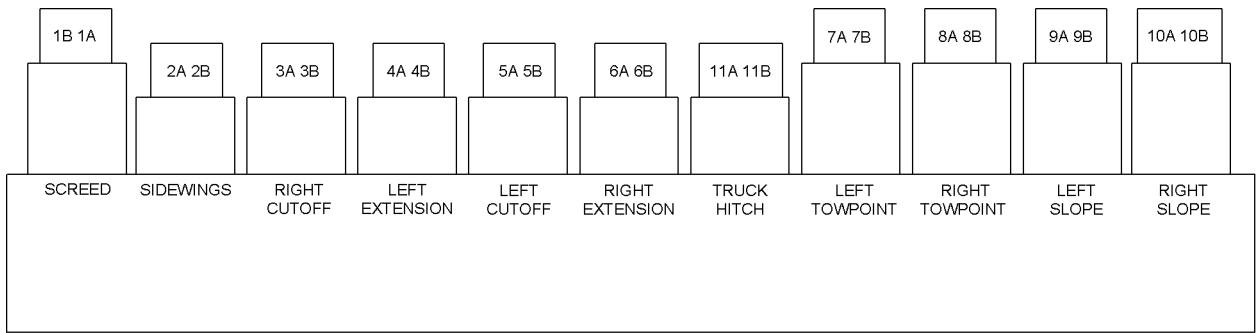

THRU SLOTTED PANEL

VALVE MANIFOLD ELECTRICAL LAYOUT

Section 4 MAINTENANCE

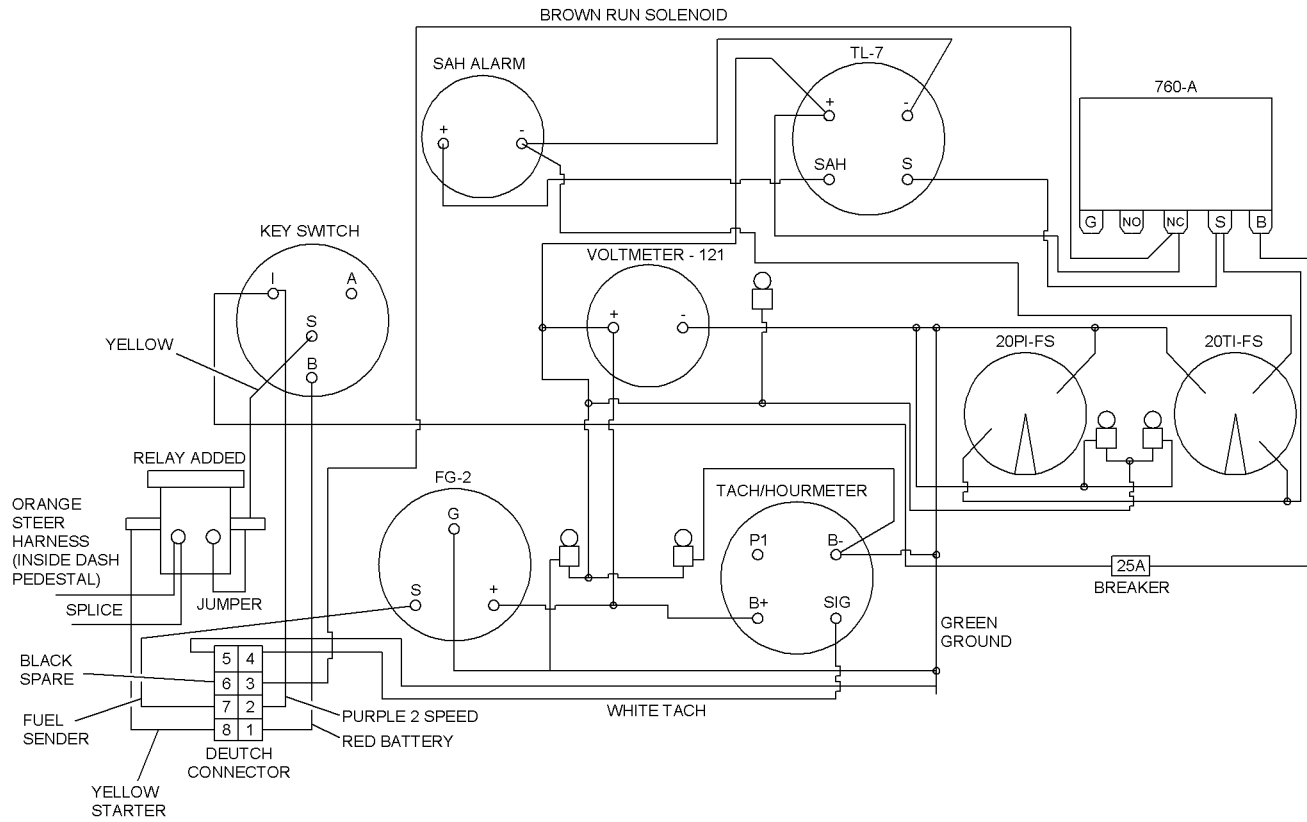

MURPHY PANEL ELECTRICAL SCHEMATIC

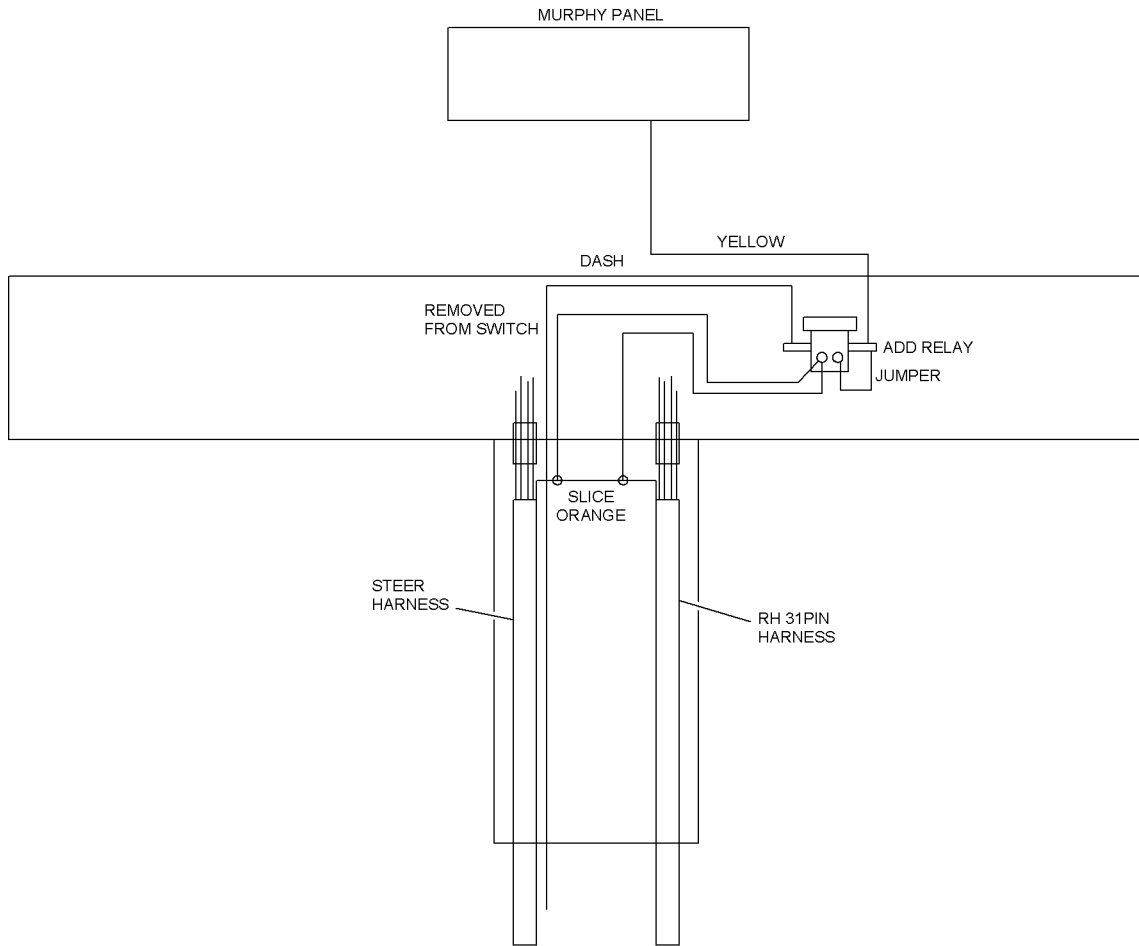

REMOVE PEDESTAL COVER ON BACK SIDE HOLDING MAIN DASH.
 LOCATE STEER HARNESS WIRES.
 ORANGE WIRE JUMPS OVER INTO HARNESS GOING DOWN TO RIGHT HAND 31 PIN CONNECTOR.
 SPLICE INTO ORANGES WIRE AT TOP OF LOOP.
 RUN WIRE OFF OF EACH SIDE OF SPLICE UP TO RELAY TERMINAL LIKE SHOWN.
 HEAT SHRINK AT SPLICES TO PROTECT.
 REMOVE YELLOW WIRE OFF AT KEY SWITCH AND RUN OVER TO RELAY AS SHOWN (ADD TO WIRES AS NEEDED).
 RUN WIRES TO LEFT HAND LARGE TERMINAL.
 RUN ANOTHER YELLOW WIRE FROM RIGHT TERMINAL OF RELAY BACK TO KEY SWITCH.
 JUMPER ON RELAY FROM RIGHT LARGE TERMINAL TO SMALL RIGHT TERMINAL.1

STARTER PROTECTION ELECTRICAL SCHEMATIC

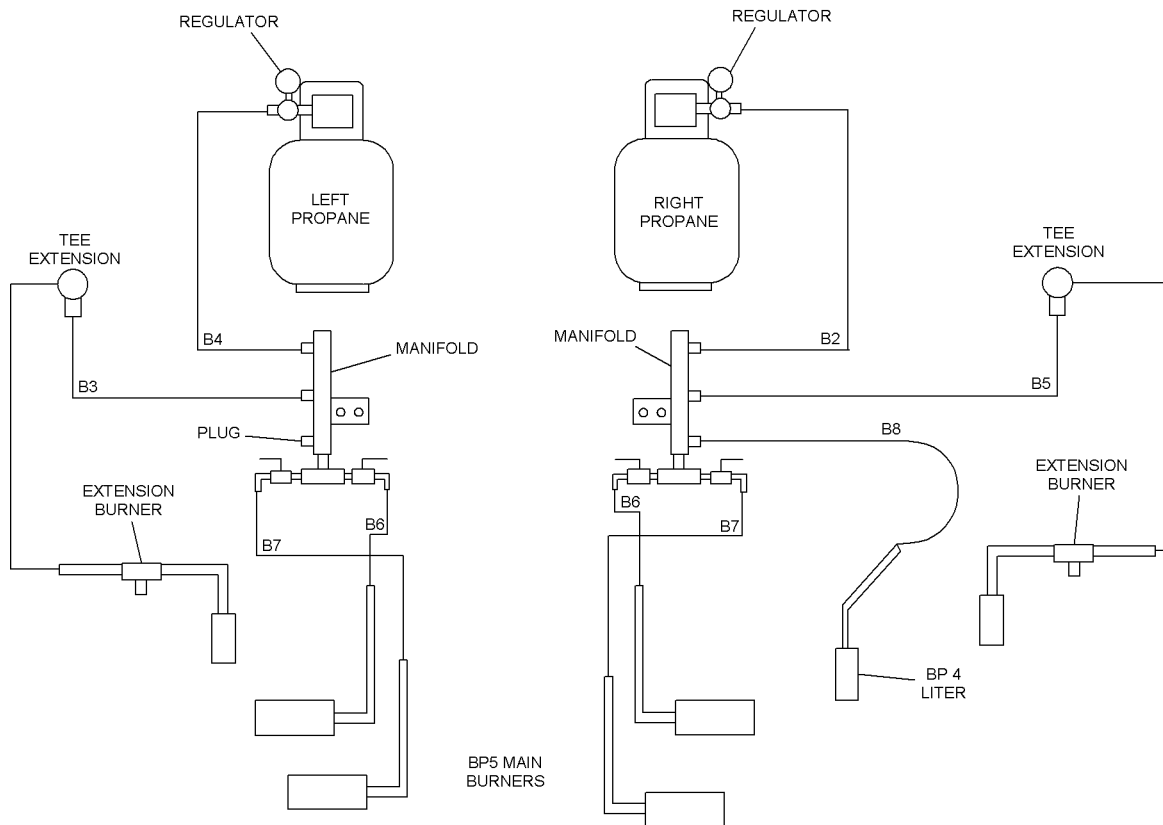

BURNER HYDRAULIC SCHEMATIC

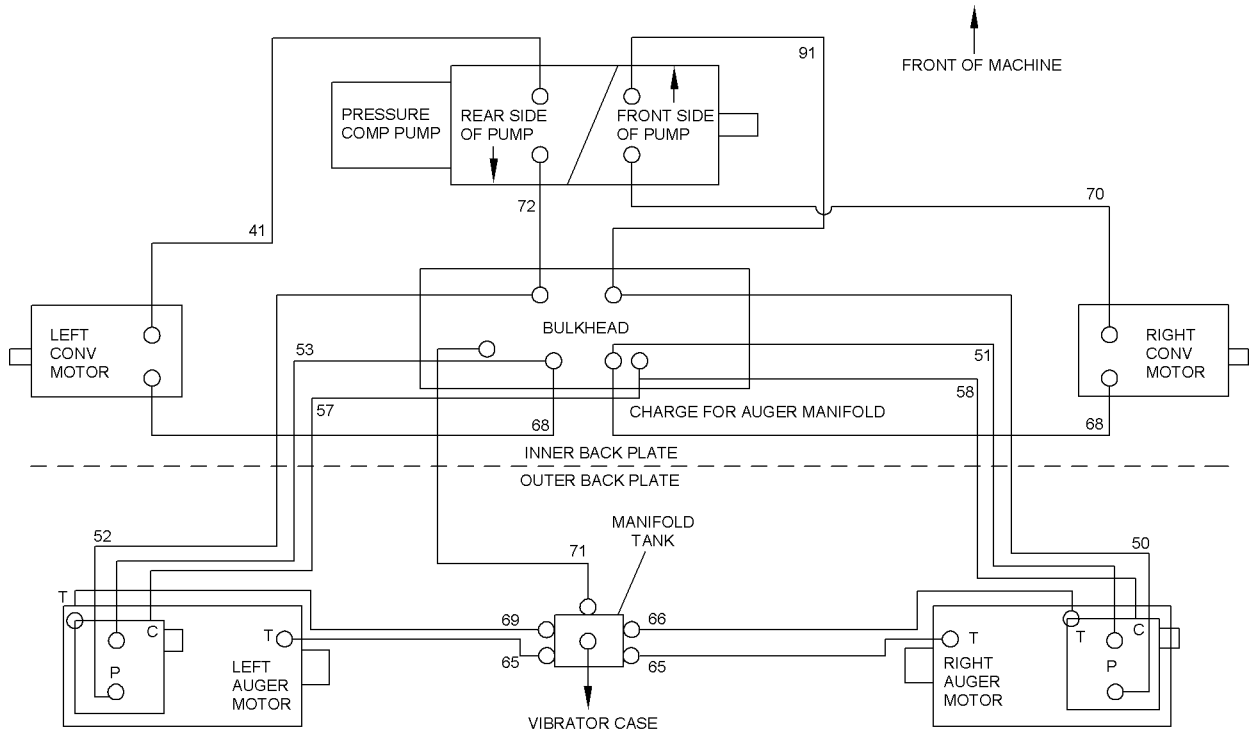

CONVEYOR PUMP HYDRAULIC SCHEMATIC

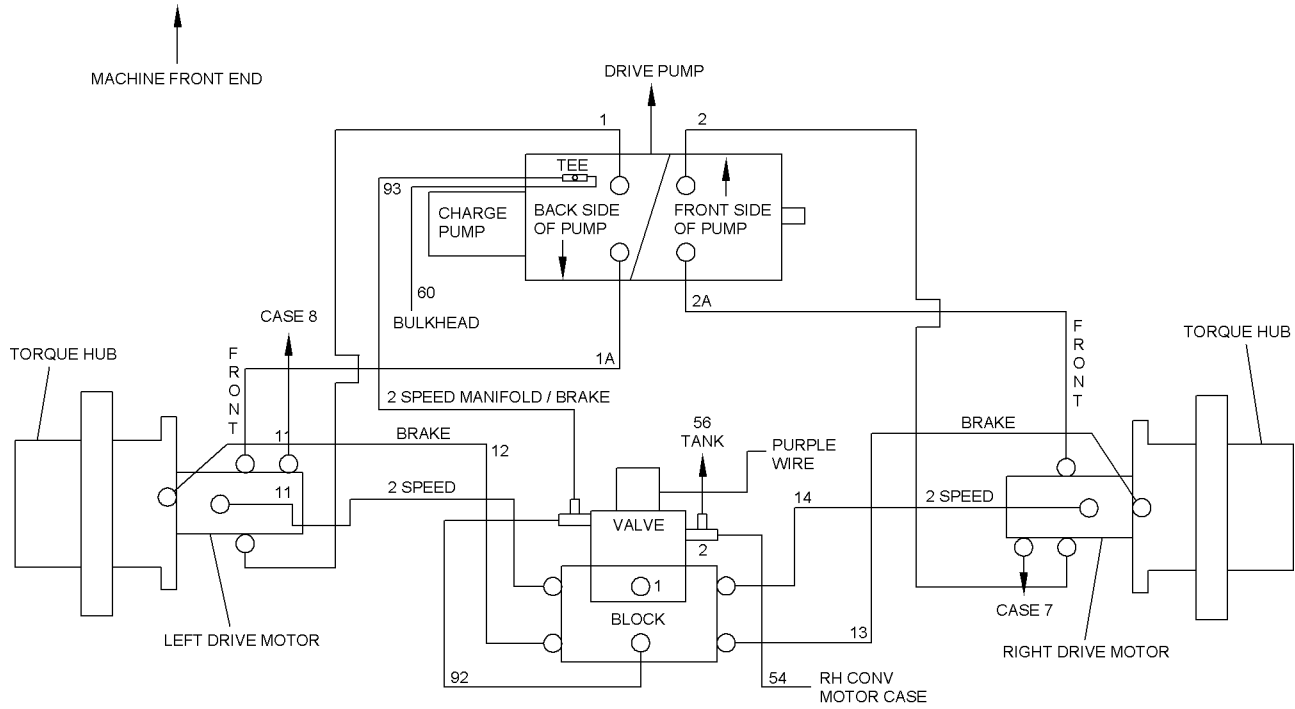

LEFT AND RIGHT DRIVE MOTOR HYDRAULIC SCHEMATIC

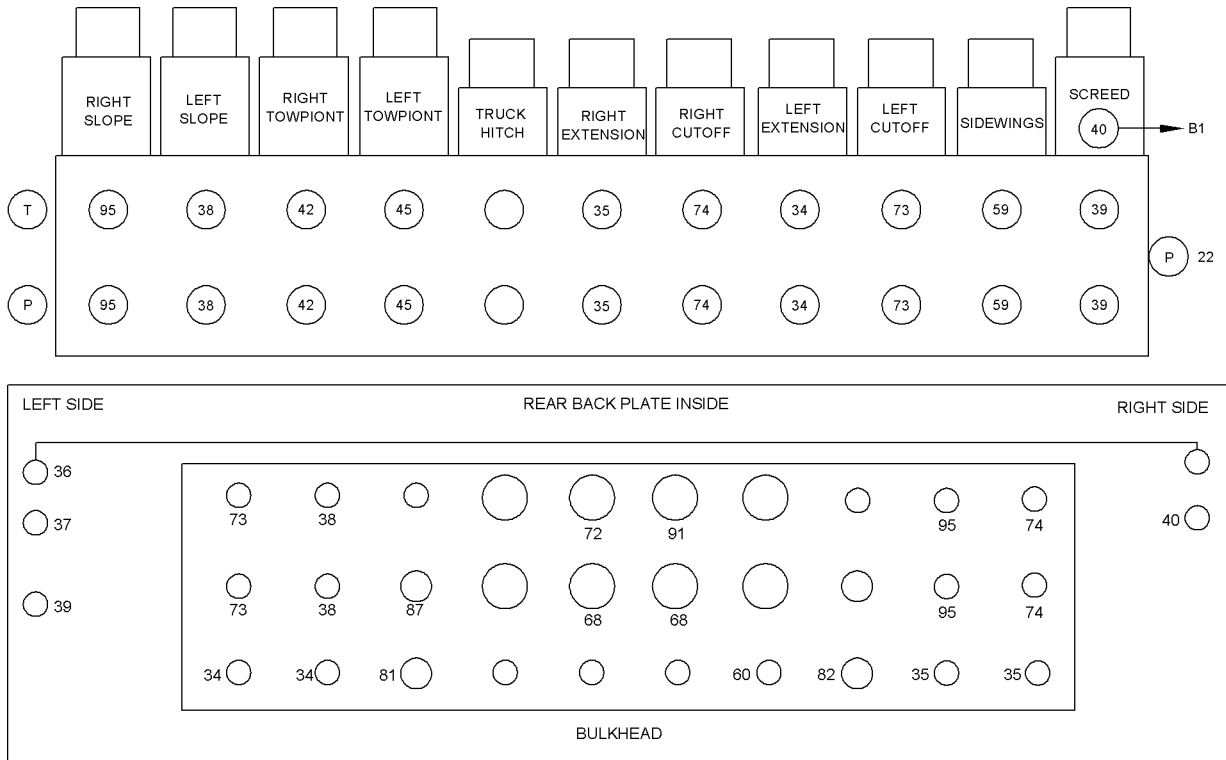

MANIFOLD TO BULKHEAD HYDRAULIC LAYOUT

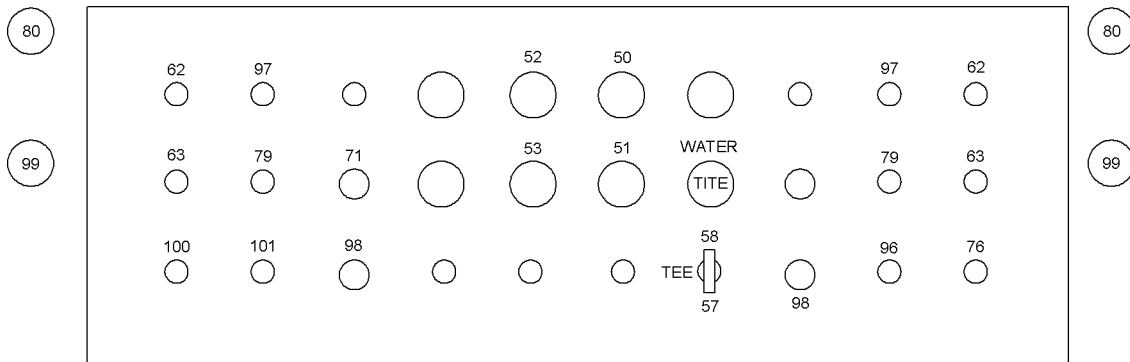

- 50-C1 PORT ON RIGHT AUGER MANIFOLD
- 51-A1 PORT ON RIGHT AUGER MANIFOLD
- 52-C1 PORT ON LEFT MANIFOLD
- 53-A1 PORT ON LEFT MANIFOLD
- 57/58 CHARGE PRESSURE FOR AUGER MANIFOLD
- 62- RIGHT AND LEFT CUTOFF CYLINDER TOP
- 63- RIGHT AND LEFT CUTOFF CYLINDER BOTTOM
- 71- FRONT PORT ON TANK MANIFOLD
- 76- RIGHT EXTENSION REAR PORT
- 79- LEFT AND RIGHT SLOPE BOTTOM
- 80- TOP OF LEFT AND RIGHT SCREED LIFT CYLINDER
- 96- RIGHT EXTENSION FRONT PORT
- 97- LEFT AND RIGHT SLOPE TOP
- 98- LEFT AND RIGHT VIBRATOR MOTOR TOP PORT
- 99- LEFT AND RIGHT BOTTOM SCREED LIFT CYLINDER
- 100- FRONT PORT ON SELECTOR VALVE AUGER LIFT
- 101- REAR PORT ON SELECTOR VALVE AUGER LIFT

OUTSIDE BULKHEAD HYDRAULIC LAYOUT



OUTSIDE BULKHEAD TO SCREED HYDRAULIC SCHEMATIC

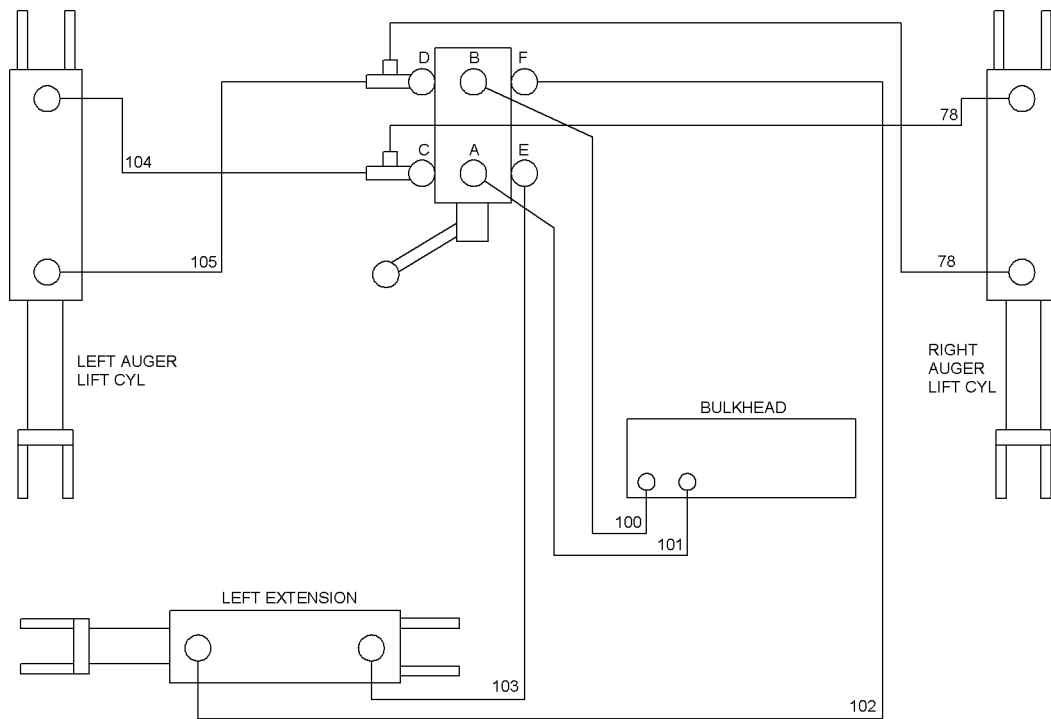

SELECTOR VALVE AUGER RAISE HYDRAULIC SCHEMATIC

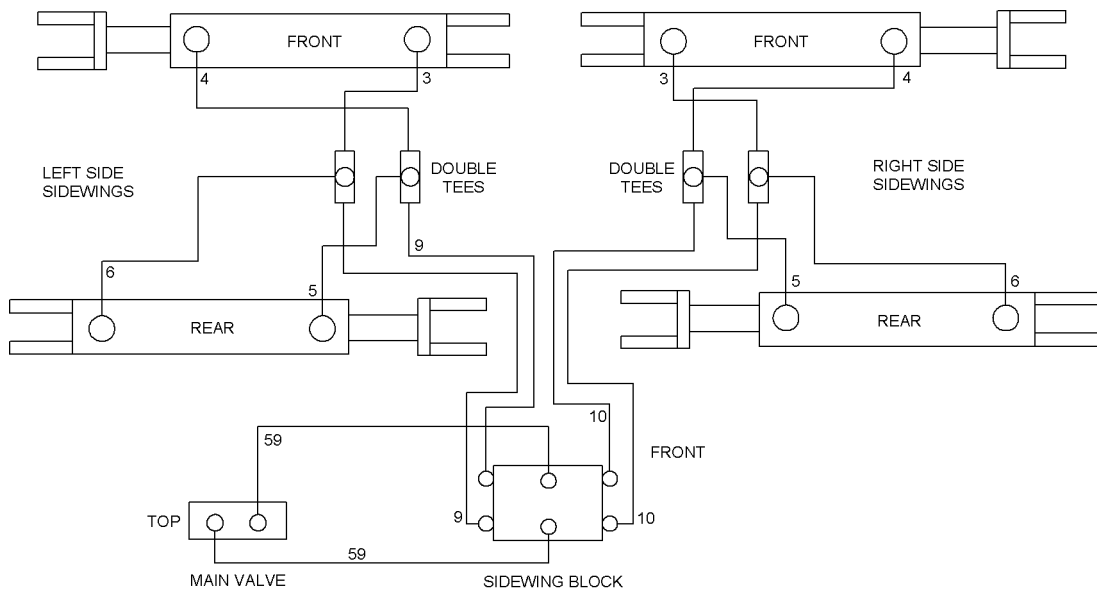

SIDEWING HYDRAULIC SCHEMATIC

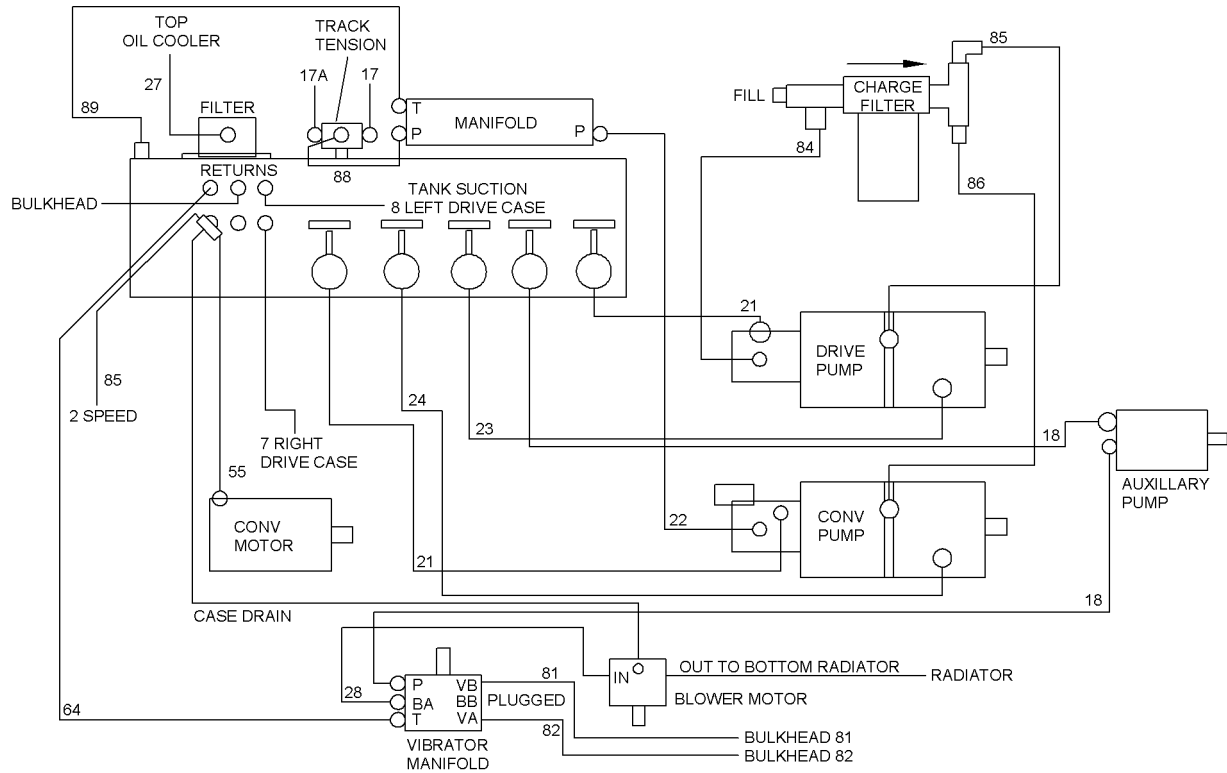

TANK AND CASE HYDRAULIC SCHEMATIC

TROUBLESHOOTING

GENERAL

The troubleshooting chart below identifies the most common symptoms of failure. Use this chart to help identify the failed component. A separate Troubleshooting guide is provided for

troubleshooting the steering system. This also includes a Wiring Diagram (see Figure 4-12) and a Troubleshooting Logic Procedure (see Figure 4-13).

TROUBLESHOOTING CHART

SYMPTOM	CAUSE	REMEDY
Engine does not start	Defective batteries or low battery charge MASTER switch not in ON position Insufficient fuel supply Fault in engine Safety switch faulty Wires not making good connection on solenoid Plug in switch box unplugged Solenoid plunger sticking Fuel solenoid coil defective Starter or solenoid faulty Neutral switch defective Cummins starter relay faulty	Replace or charge battery as applicable. Set switch to the ON position. Fill fuel tank. Refer to Cummins engine manual. Replace. Make sure wires are tight. Plug back in. Clean plunger. Replace coil. Replace or rebuild. Replace. Replace.
Engine cuts off and will not start (Turns over but will not start)	Low fuel Faulty fuel solenoid	Add fuel to fuel tank. Replace solenoid.
Low battery	Faulty alternator	Replace or rebuild.
Machine will not move	RUN/STOP switch faulty STEER LEFT/RIGHT switch on dash in incorrect position Electrical cord faulty Check that LEDs on steer micro are providing correct display	Check RUN/STOP switch. Check that STEER LEFT/RIGHT switch is in the direction of the box being used. Check electrical cord. Check that lights illuminate as follows: Two green lights illuminated all the time. One yellow light flashing one time per second. Status light not illuminated. If status light is flashing check error code list.

Section 4 MAINTENANCE



TROUBLESHOOTING CHART (Continued)

SYMPTOM	CAUSE	REMEDY
Machine will not run straight	One of the hydraulic drive motors is out of adjustment Steering control not centered Travel pump defective	Readjust motors. Center steering control. Replace pump or rebuild.
Machine does not change speed when 2-SPEED HIGH/LOW SWITCH is toggled	Defective switch Defective solenoid Defective drive motor	Replace switch. Replace solenoid. Replace drive motor.
Tracks not running smooth	Tracks too loose Too low engine RPM to hold track tension Track rollers worn Track tension pressure.	Tighten tracks Rev engine to full RPM and throttle back to one-half. Replace. Check pressure. Pressure should be set to 900 PSI.
Machine will not pull on one or both sides	Faulty hydraulic motor Pump pressure too low Faulty torque hub	Adjust Pump pressure should be 3000 PSI. Rebuild or replace.
Engine runs but no hydraulics	Engine rpm too low Pump drive coupling faulty Defective pump	Increase engine speed. Replace. Replace.
Auger hanging up or will not turn	Chain too loose Chain broke Faulty motor Solenoid valve defective Asphalt set up around auger	Adjust. Replace. Replace. Replace solenoid. Keep clean and oiled.
Screed extensions binding	Asphalt set up around extension	Keep clean and oiled.
Screed extension loose (work up and down)	Out of adjustment	Adjust hold downs on extensions.
Screed leaving streak down center of pavement	No lead crown in screed Screed worn out Extensions set too low Screed not heated properly	Crown leading edge of screed. Replace. Adjust extension. Always start out in the morning with extensions all the way up, no down pressure. Set propane pressure at 15 PSI for about 5 to 8 minutes.
Screed leaving ripples	Extension set too low Extensions work up and down Extension rod bushings worn	Readjust extensions. Adjust top guide. Replace bushings.

TROUBLESHOOTING CHART (Continued)

SYMPTOM	CAUSE	REMEDY
Flight screw locking up	Twisting screed too far Screw seized	Give screed time to react. Replace screw.
Flight screw bearing damage	Twisting screed too far Loading and unloading	Give screed time to react. Check ramps for easy access.
Flame coming out of end of screed	Raw gas from burners	Adjust burners in or out of hole. Turn cutoff valve slowly to OFF, when flame goes out turn valve back on fully.
Hydraulic oil running out of breather cap	Hydraulic oil tank overfilled Air in bottom of tank Oil over heated	Drain 5 to 6 in. (12.7 to 15 cm) from top of tank. Bleed if you don't have vent hose. Slow paver down about 10% to 15%. Check oil cooler and thermostat.
Hydraulic pump cavitating or lost power	Low level in hydraulic tank Clogged filters Suction hose loose Charge pump worn	Fill. Replace. Retighten. Rebuild.
Feeder does not work on one or both sides	Defective AUTOMATIC/MANUAL switch Solenoid defective Feeder drive chain broken Defective conveyor motor Rear conveyor shaft broken	Replace switch. Replace solenoid. Repair chain. Replace motor. Replace conveyor shaft.
Feeder flight bars hang up	Flight chains too loose	Adjust. If adjusted all the way and a link is removed you must install a ½ link.
	Feeder drive chain too loose	Adjust every 100 hours.
Loss of power to drives feeder or augers	Relief out of adjustment Piston groups worn out. Auxiliary pump worn out	Check pressure. Drive - 3000 PSI, feeders 2400 PSI, augers and cylinders 2000 PSI. Replace. Replace.
Electric screed does not work	Defective SCREED LIFT RAISE/FLOAT switch Defective solenoid	Replace switch. Replace solenoid.

Section 4

MAINTENANCE



STEERING CONTROL SYSTEM TROUBLESHOOTING GUIDE

This section outlines a strategy that can be used to solve problems in the control system. A common technique used in problem solving is exchanging components. However, a very important element necessary to the timely and successful conclusion of this activity is the correct selection of the malfunctioning component. A thorough understanding of the entire system and an elimination process leading to the malfunctioning component is absolutely necessary before starting the exchange activity.

Reduce the random exchange of components by carefully analyzing the symptoms and then conducting tests to determine which of the elements in the system is likely to be the problem. The technician should use the flow chart below as a guide to locate the problem.

Since it is new, the electronic controller is often the first component targeted for exchange. However, the malfunction of an electronic controller is extremely rare and, therefore, it should be the last component considered for replacement. In fact, the electronic controller has an internal ability to diagnose itself and the connections attached to it. This information can be very helpful in finding the problem area. If the electronic controller is responding to commands and not giving diagnostics that indicate an internal problem, the likelihood that the problem is internal to the electronic controller is remote.

FAULT CODES

When the controller detects a fault condition, it signals the specific fault using the red status LED. Under normal conditions with no error present, the red LED is off and the yellow LED blinks at a 0.5 Hz rate. If no application code is loaded in the controller, the red LED is off and the yellow LED blinks at a 10 Hz rate. All other errors (those specific to the application) are decoded by observing "blink codes" generated by the red LED.

Description of Blink Code Algorithm

If the yellow LED blinks at an unvarying 0.5 Hz rate and the red LED is blinking, the cause of the fault can be decoded from the red LED alone as follows: the red LED will flash a four bit sequence, followed by a pause, followed by the four bit sequence, the pause, and so on. The long flash, symbolized by a "-", lasts approximately one second. The short flash, symbolized by a ".", lasts approximately one-half second. The pause between the four-bit sequence lasts approximately 3.5 seconds. If more than one fault exists, each fault will be displayed in sequence before being repeated.

FAULT CODE CHART

Yellow LED (Mode)	Red LED (Status)	System Status:
10 Hz blink rate	Off	No application loaded
0.5 Hz blink rate	Off	Application loaded and no error
0.5 Hz blink rate	4 bit blink code to describe fault	Application loaded and error

Blink Code Translation

Fault Code	Flash Bit Sequence	Device at Fault	Cause of Fault	Machine Response
1	..._	Speed pot, unidirectional command input	Voltage signal is out of range or input is uncalibrated.	No output from the speed pot will cause machine to stop.
2	..._	Max speed pot, unidirectional command input	Voltage signal is out of range or input is uncalibrated.	No output from the max speed pot. Machine will stop.
3	.._..	FNR pot Bi-directional command input	Voltage signal is out of range or input is uncalibrated.	FNR command will return to neutral and machine will stop.
4	..._.	Steer pot Bi-directional command input	Voltage signal is out of range or input is uncalibrated.	Machine will steer straight at any handle setting.
5	..._.	FNR Object	RPM below 200, or no RPM at all.	Machine will revert to neutral causing the machine to stop.
7	..._.	Left Valve	Uncalibrated.	Machine will revert to neutral causing the machine to stop.
8	..._.	Right Valve	Uncalibrated.	Machine will revert to neutral causing the machine to stop.
9	..._.	Right Valve Forward Coil	Open or Short.	Machine will revert to neutral causing the machine to stop.
10	..._.	Right Valve Reverse Coil	Open or Short.	Machine will revert to neutral causing the machine to stop.
11	..._.	Left Valve Forward Coil	Open or Short.	Machine will revert to neutral causing the machine to stop.
12	..._.	Left Valve Reverse Coil	Open or Short.	Machine will revert to neutral causing the machine to stop.

"."= short flash = 0

"_" = long flash = 1

Section 4 MAINTENANCE



STEERING SYSTEM WIRING

Wiring Guidelines

1. Protect all wires from mechanical abuse. Wire can be run in flexible metal or plastic conduits.
2. Use 85°C wire with abrasion resistant insulation. 105°C wire should be considered near hot surfaces.
3. Use #18 gauge wire or greater. #14 or #16 wire is preferred.
4. Separate high current wires such as solenoids, lights, alternators, or fuel pumps from control wires.
5. Run wires along the inside of, or close to, metal machine frame surfaces where possible. This simulates a shield, which will minimize the effects of EMI/RFI radiation.
6. Do not run the wires near sharp metal corners. Consider running the wire through a grommet when rounding a corner.
7. Do not run wires near hot machine members.

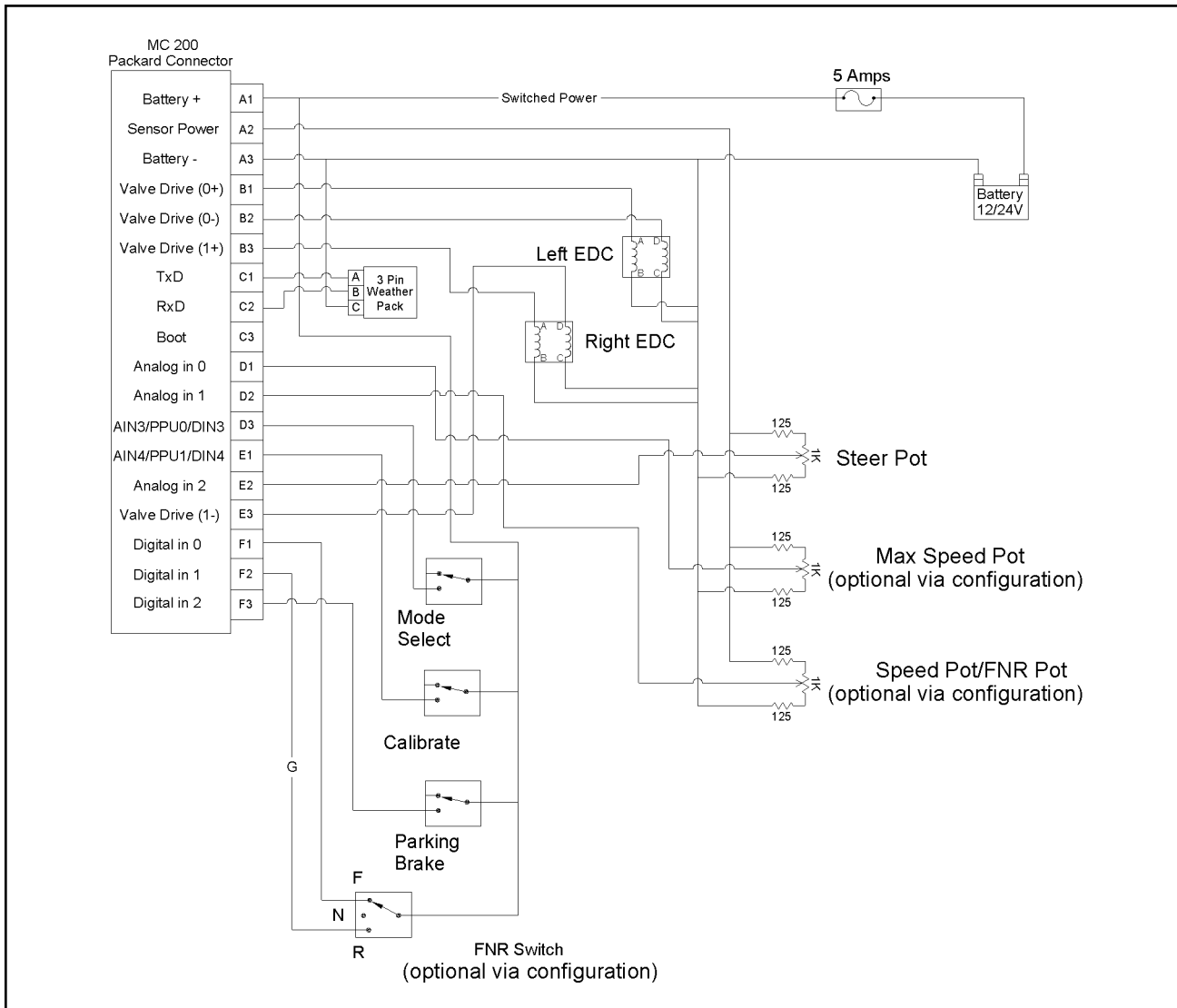
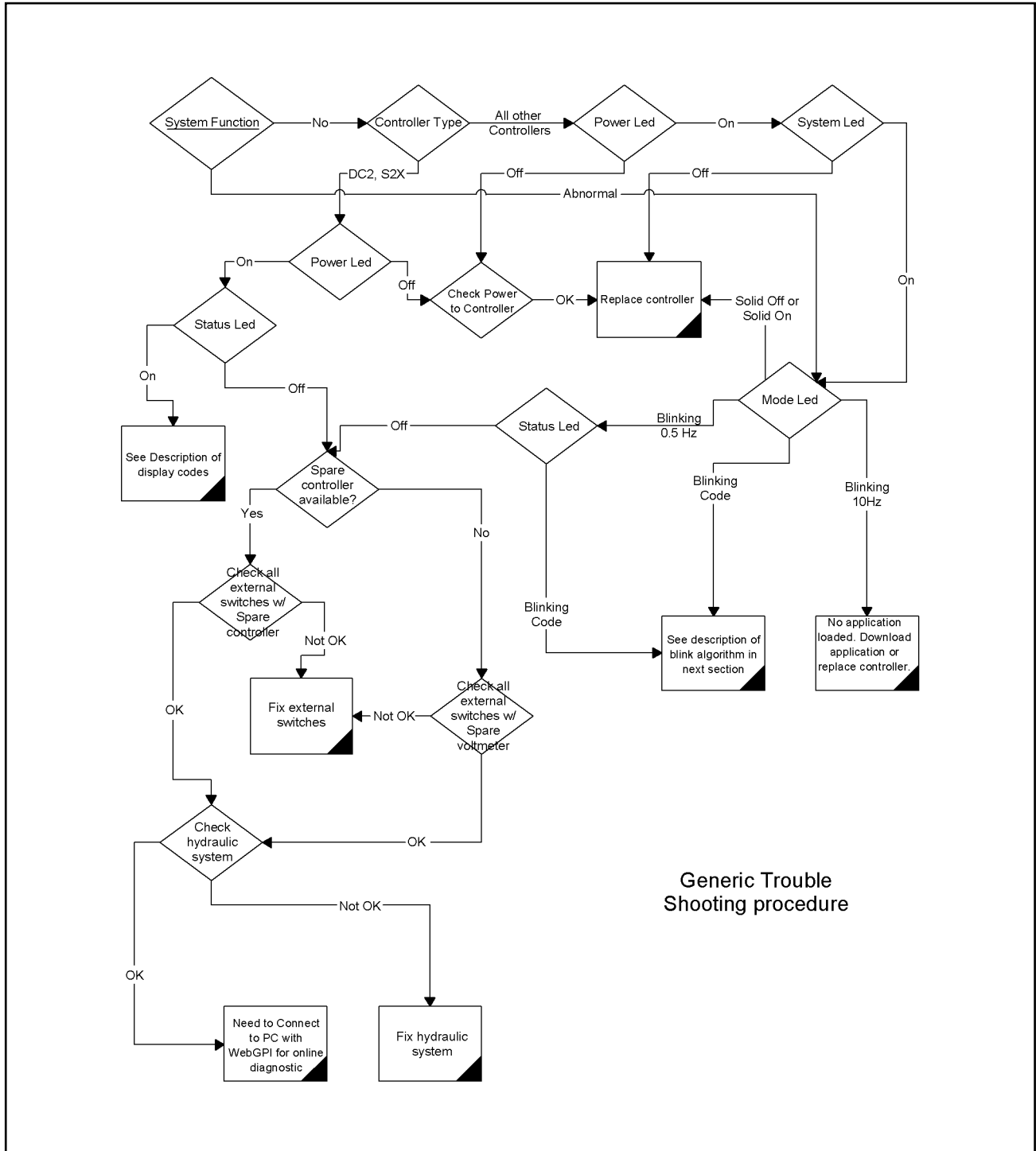

FIGURE 4-13 STEERING WIRING DIAGRAM



Generic Trouble Shooting procedure

FIGURE 4-14 STEERING TROUBLESHOOTING GUIDE



ILLUSTRATED PARTS LIST

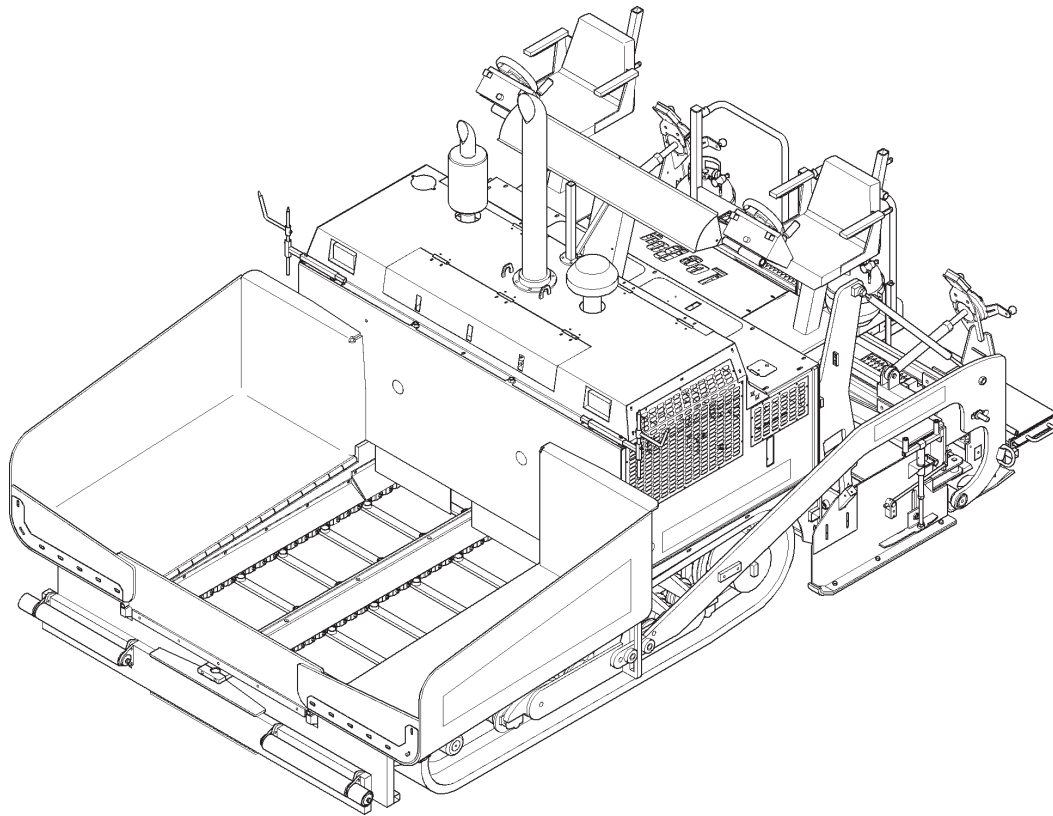

8816 CONVEYOR PAVER

Manual No. 981620

TABLE OF CONTENTS

	Page
INTRODUCTION	IPL-3
NUMERICAL INDEX	IPL-3
EQUIPMENT DESIGNATOR INDEX	IPL-3
DETAILED PARTS LIST	IPL-3
FIGURE 1 - LPG TANKS AND STAIRWAY REMOVAL	IPL-4
FIGURE 2 - FLIGHT SCREW ASSEMBLY, RH	IPL-6
FIGURE 3 - FLIGHT SCREW ASSEMBLY, LH	IPL-10
FIGURE 4 - SCREED ARM REMOVAL, LH	IPL-14
FIGURE 5 - SCREED ARM REMOVAL, RH	IPL-16
FIGURE 6 - END GATE REMOVAL, LH	IPL-18
FIGURE 7 - END GATE REMOVAL, RH	IPL-20
FIGURE 8 - EXTENSION REMOVAL, LH	IPL-22
FIGURE 9 - EXTENSION REMOVAL, RH	IPL-24
FIGURE 10 - WALKBOARD & CROWN ADJUSTMENT REMOVAL	IPL-26
FIGURE 11 - SLIDE ASSEMBLY, RH	IPL-30
FIGURE 12 - SLIDE ASSEMBLY, LH	IPL-32
FIGURE 13 - VIBRATOR REMOVAL, LH	IPL-34
FIGURE 14 - VIBRATOR REMOVAL, RH	IPL-38
FIGURE 15 - STAIRWAY ASSEMBLY	IPL-42
FIGURE 16 - SCREED ARM ASSEMBLY	IPL-44
FIGURE 17 - END GATE ASSEMBLY	IPL-46
FIGURE 18 - EXTENSION ASSEMBLY	IPL-48
FIGURE 19 - VIBRATOR ASSEMBLY	IPL-54
FIGURE 20 - BURNER ASSEMBLY	IPL-56
FIGURE 21. OPERATORS PLATFORM	IPL-60
FIGURE 22. REAR AUGER ASSEMBLY	IPL-64
FIGURE 23. FLOOR BOARD ASSEMBLY	IPL-68
FIGURE 24. HOODS AND COVERS	IPL-72
FIGURE 25. TANKS	IPL-80
FIGURE 26. DRIVE CONVEYOR	IPL-84
FIGURE 27. HOPPER WINGS	IPL-86
FIGURE 28. CONVEYOR ASSEMBLYS	IPL-90
FIGURE 29. PUSHBAR	IPL-94
FIGURE 30. TRACK ASSEMBLY LH	IPL-98
FIGURE 31. DASHBOARD COMPONENTS	IPL-104
FIGURE 32. HYDRAULIC COMPONENTS	IPL-108
FIGURE 33. ENGINE COMPONENTS	IPL-110
FIGURE 34. HYDRAULIC PUMPS	IPL-114
FIGURE 35. TRUCK HITCH ASSEMBLY	IPL-116
FIGURE 36. PAVER GRADE CONTROLS SPECTRA PHYSICS	IPL-120
FIGURE 37. PAVER LEVELING CONTROL	IPL-122
FIGURE 38. MAIN HARNESS WIRING	IPL-126
INDEX BY PART DESCRIPTION	IPL-128

**This Page
Intentionally
Left Blank**



ILLUSTRATED PARTS LIST

ILLUSTRATED PARTS LIST

1. Introduction

This Illustrated Parts List (IPL), as part of the Component Maintenance Manual, is intended for use in identifying and requisitioning replacement parts.

2. Numerical Index

A numerical index is provided to supplement the detailed parts list. Part number arrangement begins at the extreme left-hand position and continues from left to right, one position at a time. The order of precedence is as follows: Letters A through Z; Numerals 0 through 9. The alpha "O" shall be considered as a numeric zero. Each part number provides a reference to its appearance in the IPL by figure and item number.

3. Equipment Designator Index

If equipment designators are used in place of part numbers at any place in the IPL, an Equipment Designator Index is provided listing all equipment designators listed in the illustrated parts list.

4. Detailed Parts List

A. How to Use the IPL

- (1) The figure number refers to the corresponding illustration.
- (2) The item number corresponds to the item number shown for the part in the illustration.
- (3) If standard parts (those with AN, MS, NAF, NAS. prefixes) are used the standard part number is listed in the part number column.
- (4) Part quantities listed are for one component or subcomponent. For example, if the parts list shows two platform assemblies, the quantities shown for the parts in the platform assembly is for one platform assembly.
- (5) Attaching parts are captioned ATTACHING PARTS and are listed immediately following the part(s) attached. The -----*----- symbol follows the last item of the attaching parts group. The quantity listed for the attaching parts is the quantity required to attach one item.
- (6) Parts with item numbers preceded with a dash are not illustrated.

- (7) If a company other than Leeboy is referred to as the original manufacturer of some of the parts, these parts may carry the original manufacturers part number or a Leeboy part number. These manufacturers are identified by an appropriate vendor code following the nomenclature. If the part number in the part number column is a Leeboy part number, the original manufacturer's part number is given after his vendor code. Vendor codes are in accordance with the current issue of Cataloging Handbook "Commercial and Government Entity" (H4-1 and H4-2) and are preceded by the capital letter "V".
- (8) When a Vendor Code cannot be obtained from the H4-1 and H4-2 Cataloging Handbook, the manufacturer's full name and address is included in the parts list. Government standard parts, such as, AN, MS, NAF, and NAS parts are not identified with a Vendor Code.

B. General System of Assembly Order - Detailed Parts List

The indenture system used in the Detailed Parts List shows relationship of parts and assemblies to next higher assemblies or installations, as follows:

1 2 3 4 5 6 7

Installation

- Detail parts for installation
- Assembly
- Attaching parts for assemblies
- -----*-----
- Detail parts for assembly
- Sub-assembly
- Attaching parts for sub-assembly
- -----*-----
- Detail parts for sub-assembly
- Assembly
- Attaching parts for sub-sub-assembly
- -----*-----
- Detail parts for sub-sub-assembly

ILLUSTRATED PARTS LIST

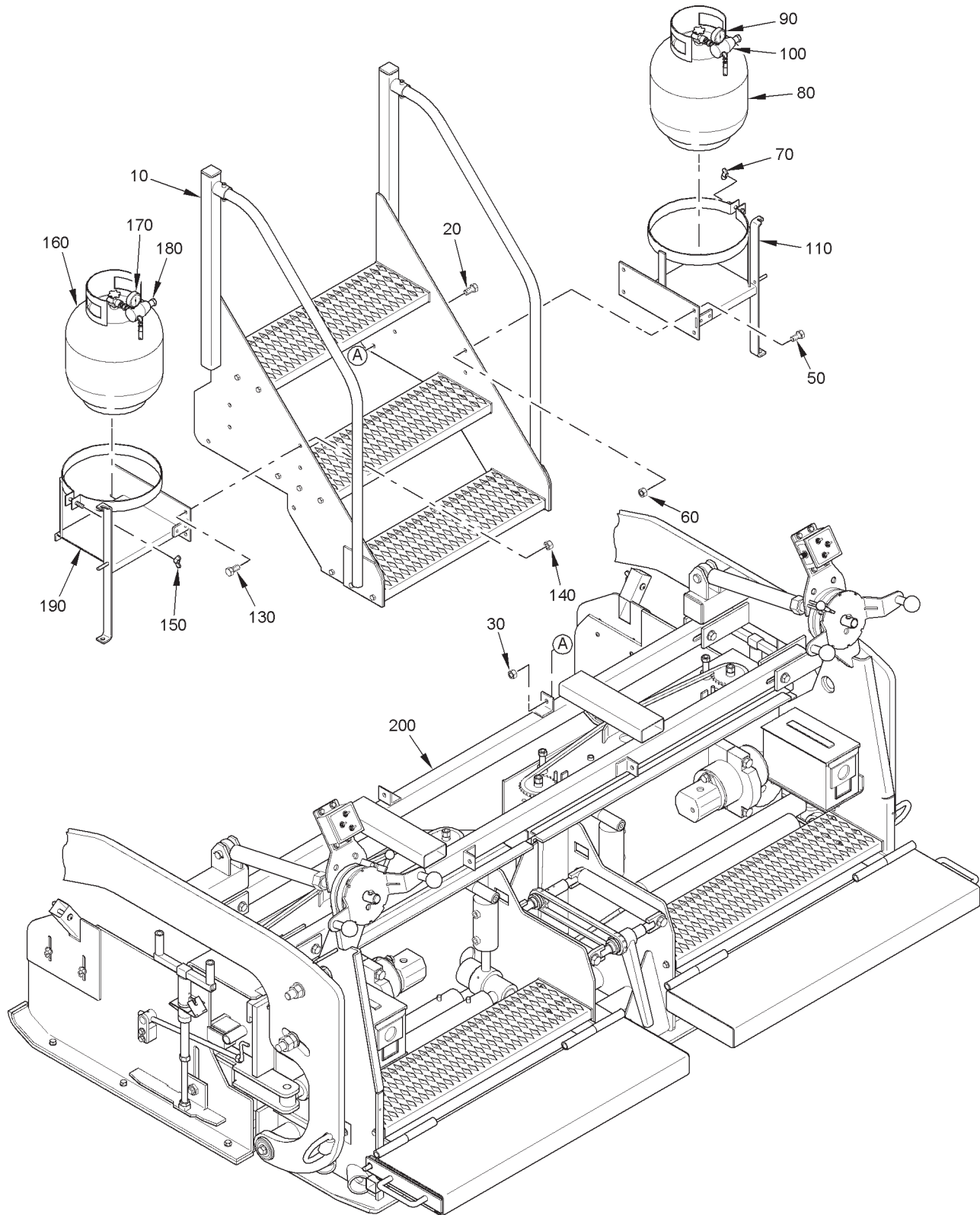

FIGURE 1. LPG TANKS AND STAIRWAY REMOVAL

FIGURE 1. LPG TANKS AND STAIRWAY REMOVAL

FIG ITEM	PART NUMBER	NOMENCLATURE							UNITS PER ASSY
		1	2	3	4	5	6	7	
1		LPG TANKS AND STAIRWAY REMOVAL							
-1	980501	MFG, SCREED 8816							REF
-2	AG32222	DECAL KIT, 8816, DECORATIVE							1
-4	859782	DECAL KIT, 8816, WARNINGS							1
10	980444	• ASSEMBLY, STAIRWAY (SEE FIG 15 FOR BREAKDOWN)							1
-11	859766	DASH DECAL							1
		ATTACHING PARTS							
20	102-405-1A	• CAPSCREW, 1/2" - 13 X 1 HEX							4
30	116-5	• NUT, 1/2" - 13 HEX							4
		-----*-----							
-40	853941	• ASSEMBLY, LPG BOTTLE HOLDER							1
		ATTACHING PARTS							
50	102-405-1A	• CAPSCREW, 1/2" - 13 X 1 HEX							4
60	116-5	• NUT, 1/2" - 13 HEX							4
		-----*-----							
70	920070	•• NUT, 3/8" - 16 WING							1
80	230010	•• TANK, L.P.G., 20 LBS							1
90	230110	•• GAUGE, PRESSURE, L.P.G.							1
100	982515	•• REGULATOR, L.P.G.,							1
110	853941	•• L.P.G. BOTTLE HOLDER ASSEMBLY							1
-120	853941	• ASSEMBLY, LPG BOTTLE HOLDER							1
		ATTACHING PARTS							
130	102-405-1A	• CAPSCREW, 1/2" - 13 X 1 HEX							4
140	116-5	• NUT, 1/2" - 13 HEX							4
		-----*-----							
150	920070	•• NUT, 3/8" - 16 WING							1
160	230010	•• TANK, L.P.G., 20 LBS							1
170	230110	•• GAUGE, PRESSURE, L.P.G.							1
180	982515	•• REGULATOR, L.P.G.,							1
190	853941	•• L.P.G. BOTTLE HOLDER ASSEMBLY							1
200	1NONUMBER200	•• FRAME ASSEMBLY							REF

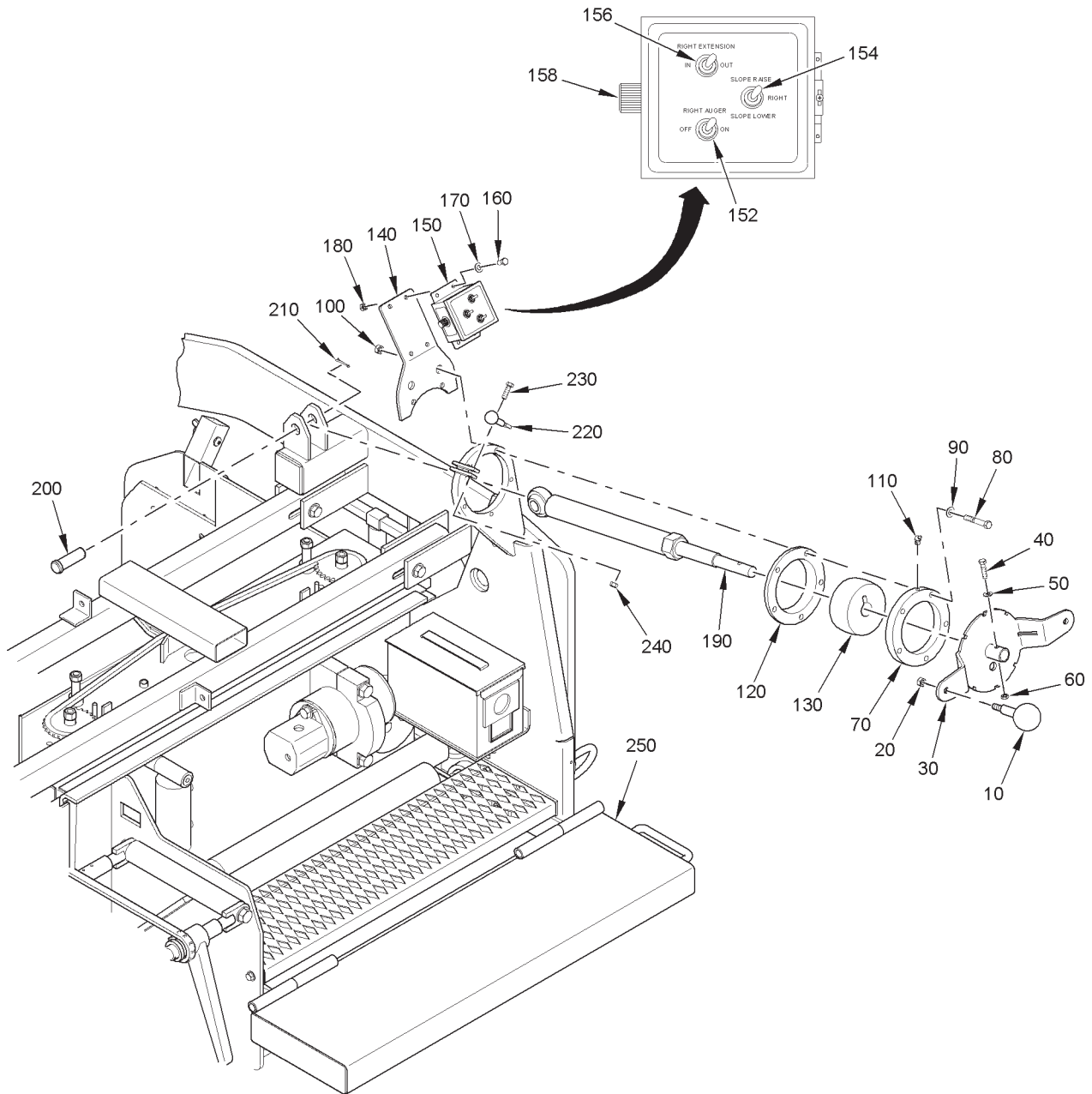

FIGURE 2. FLIGHT SCREW ASSEMBLY, RH

FIGURE 2. FLIGHT SCREW ASSEMBLY, RH

FIG ITEM	PART NUMBER	NOMENCLATURE							UNITS PER ASSY
		1	2	3	4	5	6	7	
2									
-1	1NONUMBER100	FLIGHT SCREW ASSEMBLY, RH							REF
10	981574	• KNOB, REVOLVING BALL							2
		ATTACHING PARTS							
20	116-3	• NUT, 3/8" - 16 HEX							1
		-----*-----							
30	981453	• HANDLE, FLIGHT SCREW							1
		ATTACHING PARTS							
40	102-207-1A	• CAPSCREW, 3/8" - 16 X 1.5 HEX							1
50	119-3	• FLAT WASHER, 3/8" SAE							1
60	116-3	• NUT, 3/8" - 16 HEX							1
		-----*-----							
70	981332	• BAR, TOP FLIGHT MOUNT							1
-72	982583	• SHIM, FLIGHT SCREW							1
		ATTACHING PARTS							
80	102-312-1A	• CAPSCREW, 7/16" - 14 X 2.75 HEX							5
90	119-4	• FLAT WASHER, 7/16" SAE							5
100	116-4	• NUT, 7/16" - 14 HEX							5
		-----*-----							
110	140610	• FITTING, GREASE, 1/4"-28							1
120	981331	• BAR, BOTTOM FLIGHT MOUNT							1
130	981328	• BEARING, FLIGHT SCREW PIVOT							1
140	981454	• BRACKET							1
150	984534R	• EXTENSION/AUGER CONTROLLER ENCLOSURE, ELECTRICAL, 3 SWITCHES							1
152	900030	• SWITCH, TOGGLE							1
154	851393	• SWITCH, TOGGLE							1
156	900030	• SWITCH, TOGGLE							1
158	980640-01	• POTENTIOMETER							1

**This Page
Intentionally
Left Blank**

FIGURE 2. FLIGHT SCREW ASSEMBLY, RH (CONTINUED)

FIG ITEM	PART NUMBER	NOMENCLATURE							UNITS PER ASSY
		1	2	3	4	5	6	7	
2									
		ATTACHING PARTS							
160	102-204-1A	• CAPSCREW, 3/8" - 16 X 0.75 HEX							4
170	119-3	• FLAT WASHER, 3/8" SAE							4
180	116-3	• NUT, 3/8" - 16 HEX							4
		-----*							
190	984559	• KIT, LOWER FLIGHT SCREW ASSEMBLY							1
		ATTACHING PARTS							
200	240030	• PIN, CLEVIS							1
210	81019	• PIN, COTTER, 0.156" X 2.50"							1
		-----*							
220	981487	• HANDLE, LOCK							1
		ATTACHING PARTS							
230	102-206-1A	• CAPSCREW, 3/8" - 16 X 1.25 HEX							1
240	116-3	• NUT, 3/8" - 16 HEX							1
		-----*							
250	2NONUMBER250	• FRAME ASSEMBLY							REF

ILLUSTRATED PARTS LIST

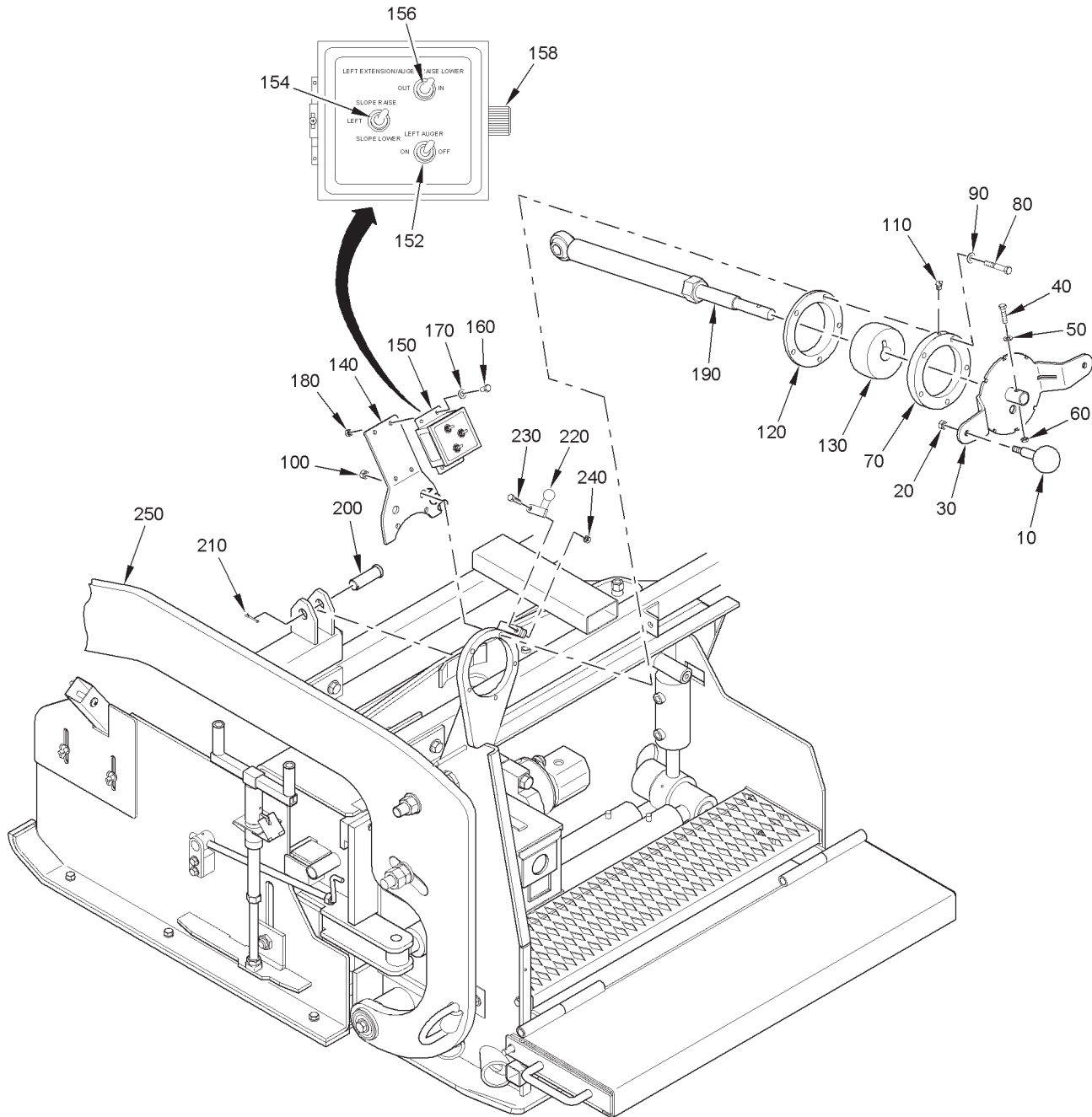

FIGURE 3. FLIGHT SCREW ASSEMBLY, LH

FIGURE 3. FLIGHT SCREW ASSEMBLY, LH

FIG ITEM	PART NUMBER	NOMENCLATURE							UNITS PER ASSY
		1	2	3	4	5	6	7	
3									
-1	2NONUMBER250	FLIGHT SCREW ASSEMBLY, LH							REF
10	981574	• KNOB, REVOLVING BALL							2
		ATTACHING PARTS							
20	116-3	• NUT, 3/8" - 16 HEX							1
		-----*-----							
30	981453	• HANDLE, FLIGHT SCREW							1
		ATTACHING PARTS							
40	102-207-1A	• CAPSCREW, 3/8" - 16 X 1.5 HEX							1
50	119-3	• FLAT WASHER, 3/8" SAE							1
60	116-3	• NUT, 3/8" - 16 HEX							1
		-----*-----							
70	981332	• BAR, TOP FLIGHT MOUNT							1
-72	982583	• SHIM, FLIGHT SCREW							1
		ATTACHING PARTS							
80	102-312-1A	• CAPSCREW, 7/16" - 14 X 2.75 HEX							5
90	119-4	• FLAT WASHER, 7/16" SAE							5
100	116-4	• NUT, 7/16" - 14 HEX							5
		-----*-----							
110	140610	• FITTING, GREASE, 1/4"-28							1
120	981331	• BAR, BOTTOM FLIGHT MOUNT							1
130	981328	• BEARING, FLIGHT SCREW PIVOT							1
140	981454	• BRACKET							1
150	984534L	• EXTENSION/AUGER CONTROLLER ENCLOSURE, ELECTRICAL, 3 SWITCHES							1
152	900030	• SWITCH, TOGGLE							1
154	900030	• SWITCH, TOGGLE							1
156	900030	• SWITCH, TOGGLE							1
158	980640-1	• POTENTIOMETER							1

**This Page
Intentionally
Left Blank**

FIGURE 3. FLIGHT SCREW ASSEMBLY, LH (CONTINUED)

FIG ITEM	PART NUMBER	NOMENCLATURE							UNITS PER ASSY
		1	2	3	4	5	6	7	
3									
		ATTACHING PARTS							
160	102-204-1A	• CAPSCREW, 3/8" - 16 X 0.75 HEX							4
170	119-3	• FLAT WASHER, 3/8" SAE							4
180	116-3	• NUT, 3/8" - 16 HEX							4
		-----*-----							
190	981451	• KIT, LOWER FLIGHT SCREW ASSEMBLY							1
		ATTACHING PARTS							
200	240030	• PIN, CLEVIS							1
210	81019	• PIN, COTTER, 0.156" X 2.50"							1
		-----*-----							
220	981487	• HANDLE, LOCK							1
		ATTACHING PARTS							
230	102-206-1A	• CAPSCREW, 3/8" - 16 X 1.25 HEX							1
240	116-3	• NUT, 3/8" - 16 HEX							1
		-----*-----							
250	3NONUMBER250	• FRAME ASSEMBLY							REF

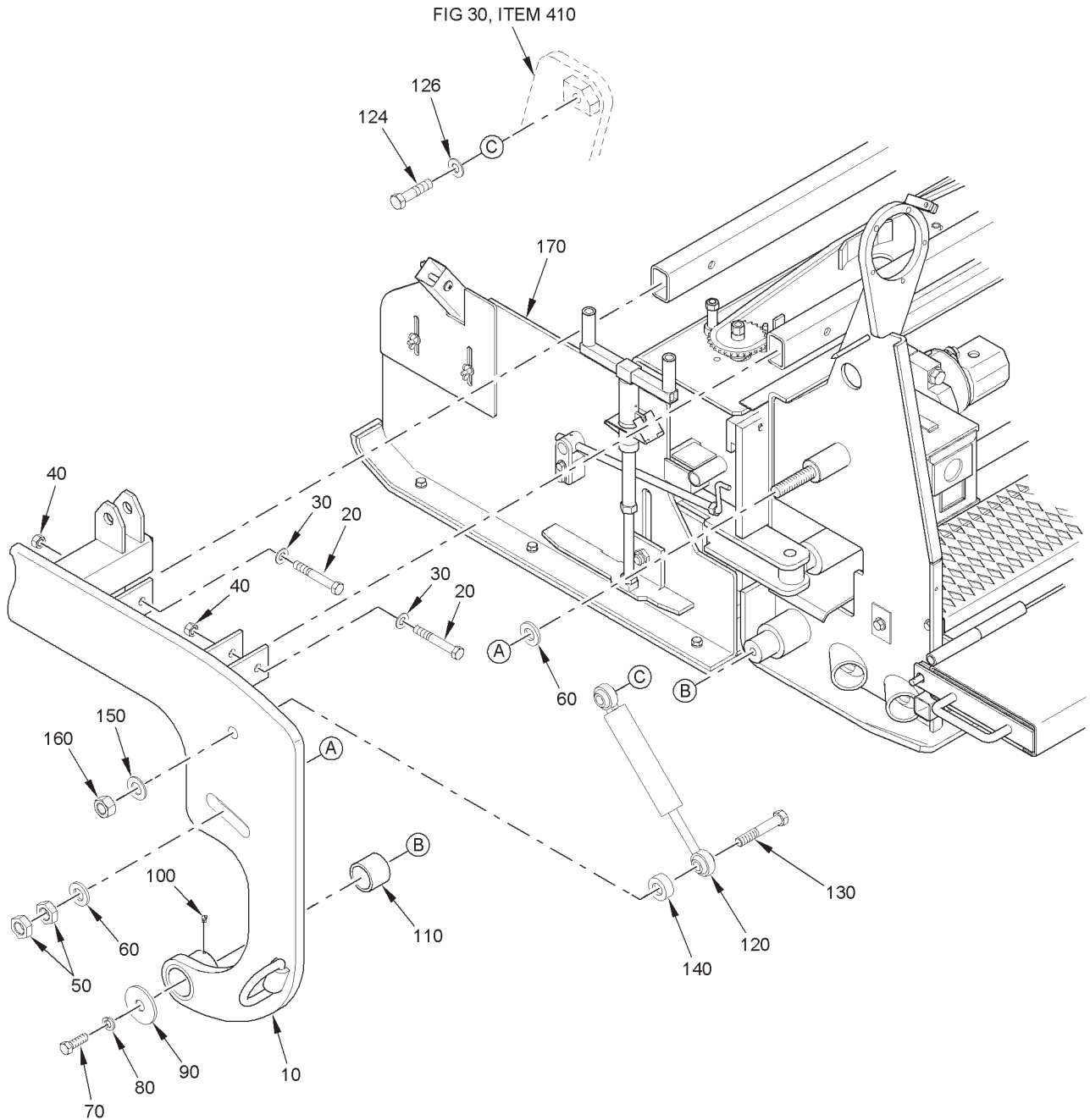

FIGURE 4. SCREED ARM REMOVAL, LH

FIGURE 4. SCREED ARM REMOVAL, LH

FIG ITEM	PART NUMBER	NOMENCLATURE							UNITS PER ASSY
		1	2	3	4	5	6	7	
4									
-1	3NONUMBER250	SCREED ARM REMOVAL, LH							REF
10	980393L	• SCREED ARM							1
		ATTACHING PARTS							
20	102-619-1A	• CAPSCREW, 5/8" - 11 X 4.5 HEX							2
30	119-7	• FLAT WASHER, 5/8" SAE							2
40	116-7	• NUT, 5/8" - 11 HEX							2
50	115-10-1	• NUT, 1" - HEX JAM							2
60	119-10	• FLAT WASHER, 1" SAE							2
70	102-609-1A	• CAPSCREW, 5/8" - 11 X 2 HEX							1
80	119-7	• FLAT WASHER, 5/8" SAE							1
90	982038	• FLAT WASHER, 3/4" ID X 3" OD X 1/4"							1
		-----*-----							
100	140610	• FITTING, GREASE, 1/4"-28							1
110	810070	• BEARING RING, INNER							1
120	980980	• HYDRAULIC CYLINDER, SCREED LIFT 8816							1
-122	980980-01	• SEAL KIT							1
		ATTACHING HARDWARE							
124	110-409-1A	• CAPSCREW, 1/2" - 13 - 2.0 HEX							1
126	119-5	• FLAT WASHER, 1/2" SAE							1
		ATTACHING PARTS							
130	102-925-1A	• CAPSCREW, 1" - 8 X 6.0 HEX							1
140	982092	• BUSHING, 1"							1
150	119-10	• FLAT WASHER, 1" SAE							1
160	116-10	• NUT, 1" - 8 HEX LOCK							1
		-----*-----							
170	980456L	• END GATE LH							AR

ILLUSTRATED PARTS LIST

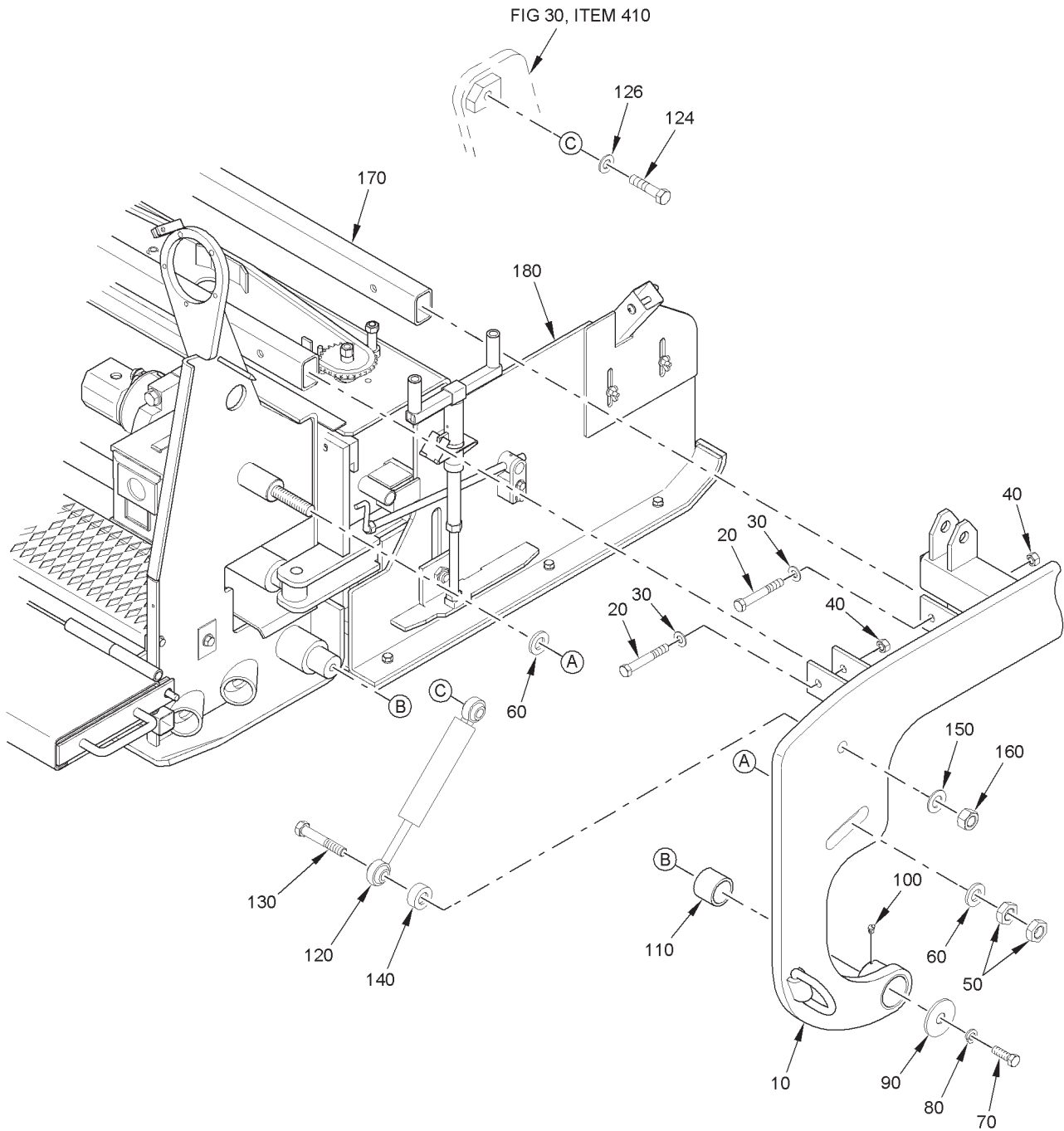

FIGURE 5. SCREED ARM REMOVAL, RH

FIGURE 5. SCREED ARM REMOVAL, RH

FIG ITEM	PART NUMBER	NOMENCLATURE	UNITS PER ASSY
5			
-1	4NONUMBER170	SCREED ARM REMOVAL, RH	REF
10	980393R	• SCREED ARM (REFER TO FIGURE 16 FOR BREAKDOWN)	1
		ATTACHING PARTS	
20	102-619-1A	• CAPSCREW, 5/8" - 11 X 4.5 HEX	2
30	119-7	• FLAT WASHER, 5/8" SAE	2
40	116-7	• NUT, 5/8" - 11 HEX	2
50	115-10-1	• NUT, 1" - HEX JAM	2
60	119-10	• FLAT WASHER, 1" SAE	2
70	102-609-1A	• CAPSCREW, 5/8" - 11 X 2 HEX	1
80	119-7	• FLAT WASHER, 5/8" SAE	1
90	982038	• FLAT WASHER, 3/4" ID X 3" OD X 1/4"	1
		-----*-----	
100	140610	• FITTING, GREASE, 1/4"-28	1
110	810070	• BUSHING	1
120	980980	• HYDRAULIC CYLINDER, SCREED LIFT 8816	1
-122	980980-01	• SEAL KIT	1
		ATTACHING HARDWARE	
124	110-409-1A	• CAPSCREW, 1/2" - 13 - 2.0 HEX	1
126	119-5	• FLAT WASHER, 1/2" SAE	1
		ATTACHING PARTS	
130	102-925-1A	• CAPSCREW, 1" - 8 X 6.0 HEX	1
140	982092	• BUSHING, 1"	1
150	119-10	• FLAT WASHER, 1" SAE	1
160	116-10	• NUT, 1" - 8 HEX LOCK	1
		-----*-----	
170	980443	• TUBE, CROSS BRACE	1
180	980456R	• END GATE RH	AR

ILLUSTRATED PARTS LIST

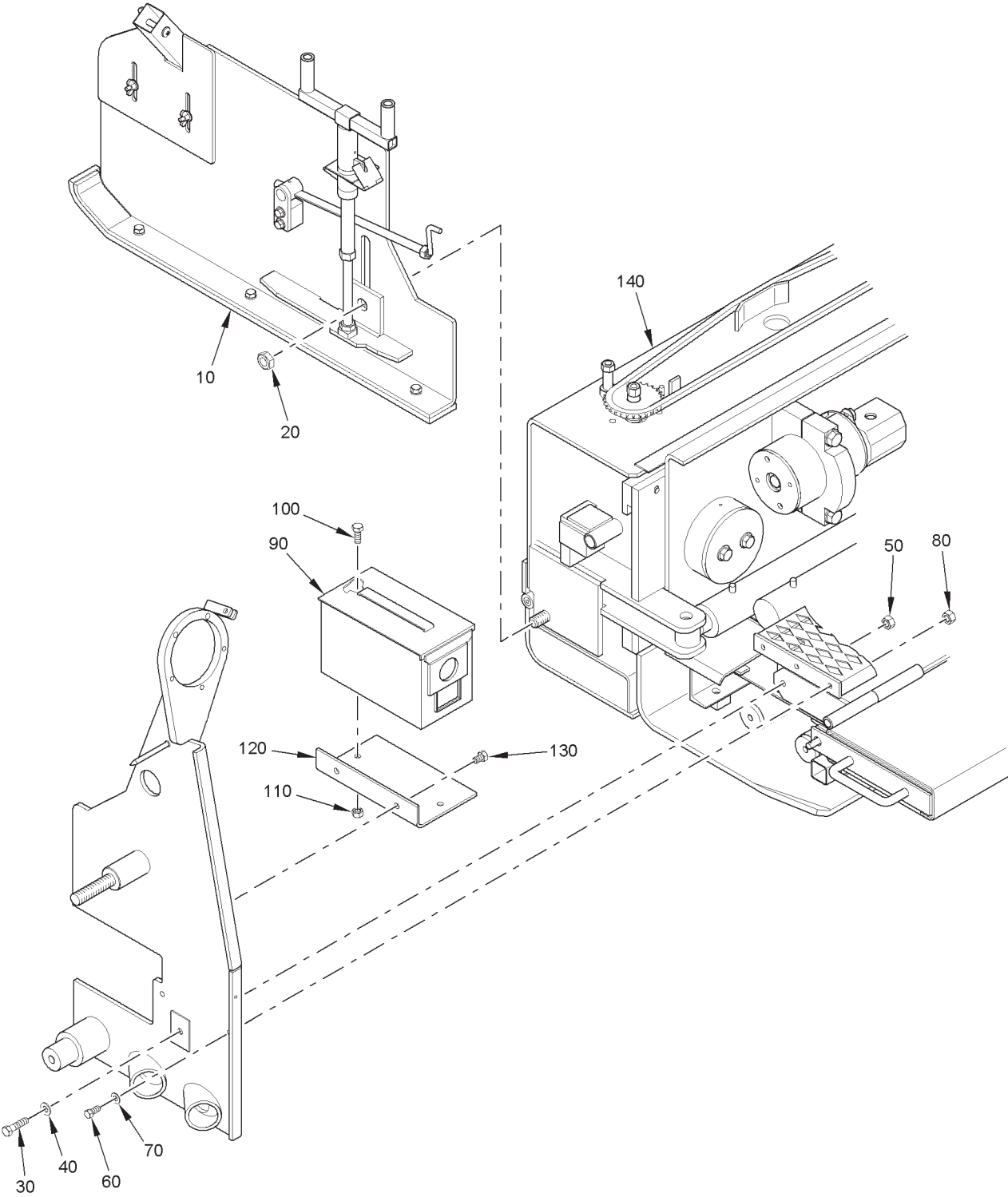

FIGURE 6. END GATE REMOVAL, LH

FIGURE 6. END GATE REMOVAL, LH

FIG ITEM	PART NUMBER	NOMENCLATURE							UNITS PER ASSY
		1	2	3	4	5	6	7	
6									
-1	5NONUMBER180	END GATE REMOVAL, LH							REF
10	980456L	• END GATE ASSEMBLY (SEE FIG 17 FOR BREAKDOWN)							1
		ATTACHING PARTS							
20	116-9	• NUT, 7/8" - 9 HEX							1
		-----*-----							
30	102-409-1A	• BOLT, 1/2" - 13 X 2.0 HEX							1
40	119-5	• FLAT WASHER, 1/2" SAE							1
50	116-5	• NUT, 1/2" - 13 HEX							1
60	102-305-1A	• BOLT, 7/16" - 14 X 1.0 HEX							2
70	119-4	• FLAT WASHER, 7/16" SAE							2
80	116-4	• NUT, 7/16" - 14 HEX							2
90	851169	• TOOL BOX							1
		ATTACHING PARTS							
100	102-305-1A	• CAPSCREW, 7/16" - 14 X 1.0 HEX							2
110	116-4	• NUT, 7/16" - 14 HEX							2
		-----*-----							
120	980429	• PLATE, TOOL BOX TRAY							1
		ATTACHING PARTS							
130	102-404-1A	• CAPSCREW, 1/2" - 13 X 0.75 HEX							2
		-----*-----							
140	6NONUMBER140	• FRAME ASSEMBLY							REF

ILLUSTRATED PARTS LIST

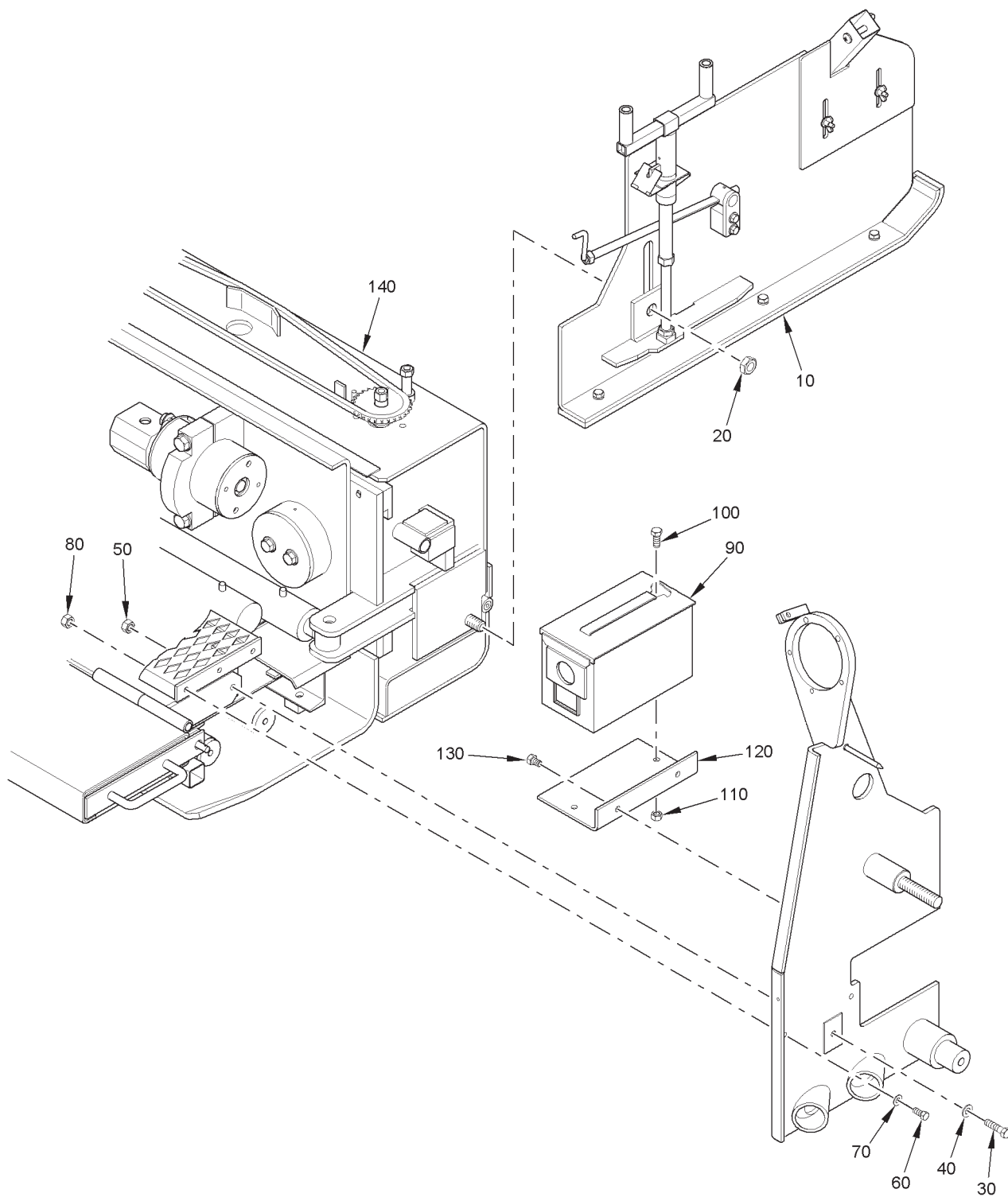

FIGURE 7. END GATE REMOVAL, RH

FIGURE 7. END GATE REMOVAL, RH

FIG ITEM	PART NUMBER	NOMENCLATURE							UNITS PER ASSY
		1	2	3	4	5	6	7	
7									
-1	6NONUMBER140	END GATE REMOVAL, RH							REF
10	980456R	• END GATE ASSEMBLY (SEE FIG 17 FOR BREAKDOWN)							1
		ATTACHING PARTS							
20	116-9	• NUT, 7/8" - 9 HEX							1
		-----*-----							
30	102-409-1A	• BOLT, 1/2" - 13 X 2.0 HEX							1
40	119-5	• FLAT WASHER, 1/2" SAE							1
50	116-5	• NUT, 1/2" - 13 HEX							1
60	102-305-1A	• BOLT, 7/16" - 14 X 1.0 HEX							2
70	119-4	• FLAT WASHER, 7/16" SAE							2
80	116-4	• NUT, 7/16" - 14 HEX							2
90	851169	• TOOL BOX							1
		ATTACHING PARTS							
100	102-305-1A	• CAPSCREW, 7/16" - 14 X 1.0 HEX							2
110	116-4	• NUT, 7/16" - 14 HEX							2
		-----*-----							
120	980429	• PLATE, TOOL BOX TRAY							1
		ATTACHING PARTS							
130	102-404-1A	• CAPSCREW, 1/2" - 13 X 0.75 HEX							2
		-----*-----							
140	7NONUMBER140	• FRAME ASSEMBLY							REF

ILLUSTRATED PARTS LIST

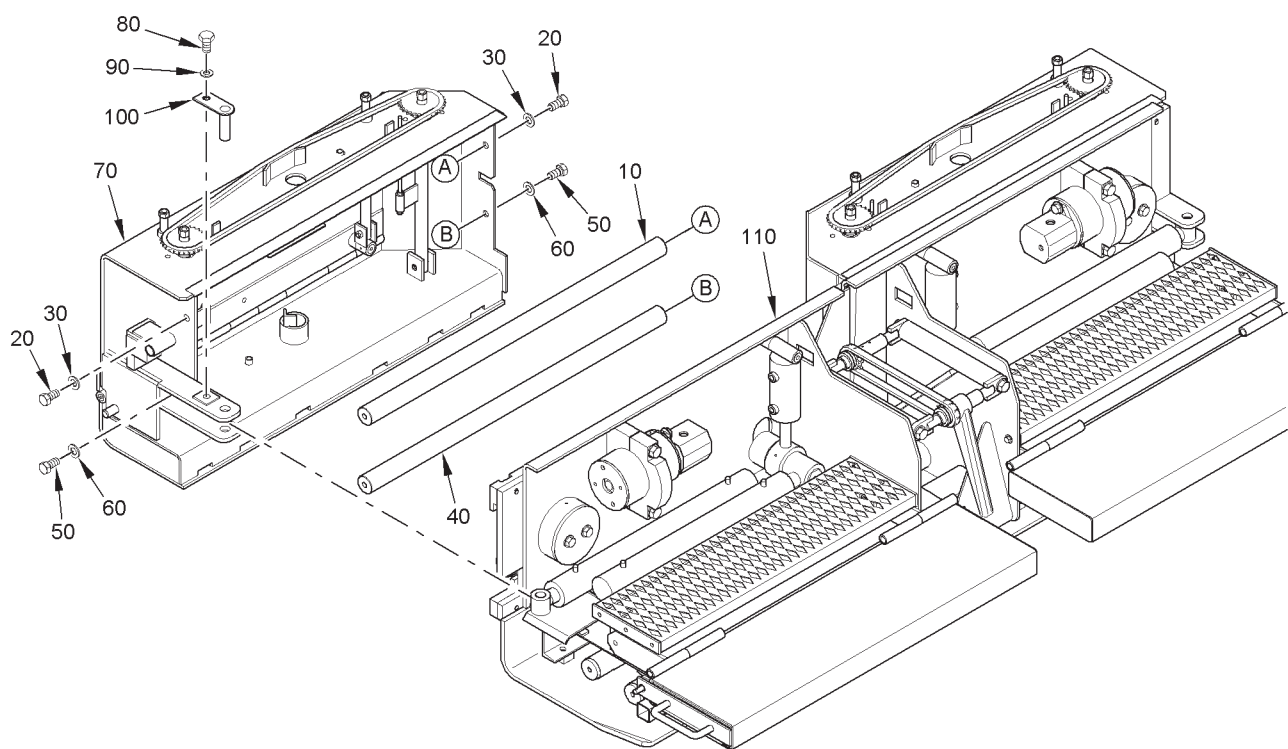

FIGURE 8. EXTENSION REMOVAL, LH

FIGURE 8. EXTENSION REMOVAL, LH

FIG ITEM	PART NUMBER	NOMENCLATURE							UNITS PER ASSY
		1	2	3	4	5	6	7	
8									
-1	7NONUMBER140	EXTENSION REMOVAL, LH							REF
10	980228	• ROD, EXTENSION							1
		ATTACHING PARTS							
20	102-707-1A	• CAPSCREW, 3/4" - 10 X 1.5 HEX							2
30	119-8	• FLAT WASHER, 3/4" SAE							2
		-----*							
40	980228	• ROD, EXTENSION							1
		ATTACHING PARTS							
50	102-707-1A	• CAPSCREW, 3/4" - 10 X 1.5 HEX							2
60	119-8	• FLAT WASHER, 3/4" SAE							2
		-----*							
70	980233L	• EXTENSION ASSEMBLY, LH (SEE FIG 18 FOR BREAKDOWN)							1
		ATTACHING PARTS							
80	102-705-1A	• CAPSCREW, 3/4" - 10 X 1.0 HEX							1
90	119-8	• FLAT WASHER, 3/4" SAE							1
100	984575	• PIN ASSEMBLY, SCREED EXTENSION							1
		-----*							
110	8NONUMBER110	• FRAME ASSEMBLY							REF

ILLUSTRATED PARTS LIST

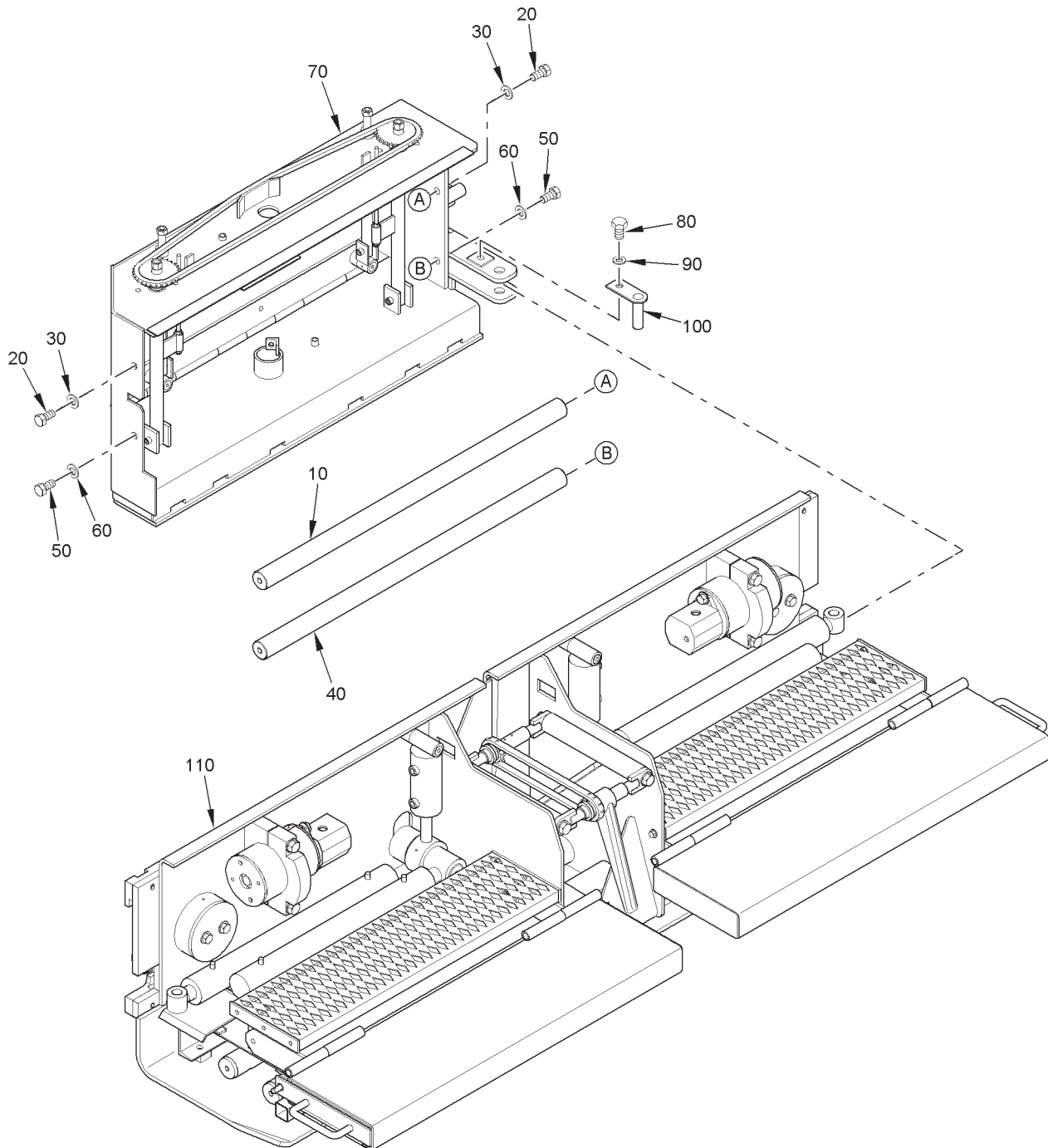

FIGURE 9. EXTENSION REMOVAL, RH

FIGURE 9. EXTENSION REMOVAL, RH

FIG ITEM	PART NUMBER	NOMENCLATURE							UNITS PER ASSY
		1	2	3	4	5	6	7	
9									
-1	8NONUMBER110	EXTENSION REMOVAL, RH							REF
10	980228	• ROD, EXTENSION							1
		ATTACHING PARTS							
20	102-707-1A	• CAPSCREW, 3/4" - 10 X 1.5 HEX							2
30	119-8	• FLAT WASHER, 3/4" SAE							2
		-----*							
40	980228	• ROD, EXTENSION							1
		ATTACHING PARTS							
50	102-707-1A	• CAPSCREW, 3/4" - 10 X 1.5 HEX							2
60	119-8	• FLAT WASHER, 3/4" SAE							2
		-----*							
70	980233R	• EXTENSION ASSEMBLY, RH (SEE FIG 18 FOR BREAKDOWN)							1
		ATTACHING PARTS							
80	102-705-1A	• CAPSCREW, 3/4" - 10 X 1.0 HEX							1
90	119-8	• FLAT WASHER, 3/4" SAE							1
100	984575	• PIN ASSEMBLY, SCREED EXTENSION							1
		-----*							
110	9NONUMBER110	• FRAME ASSEMBLY							REF

ILLUSTRATED PARTS LIST

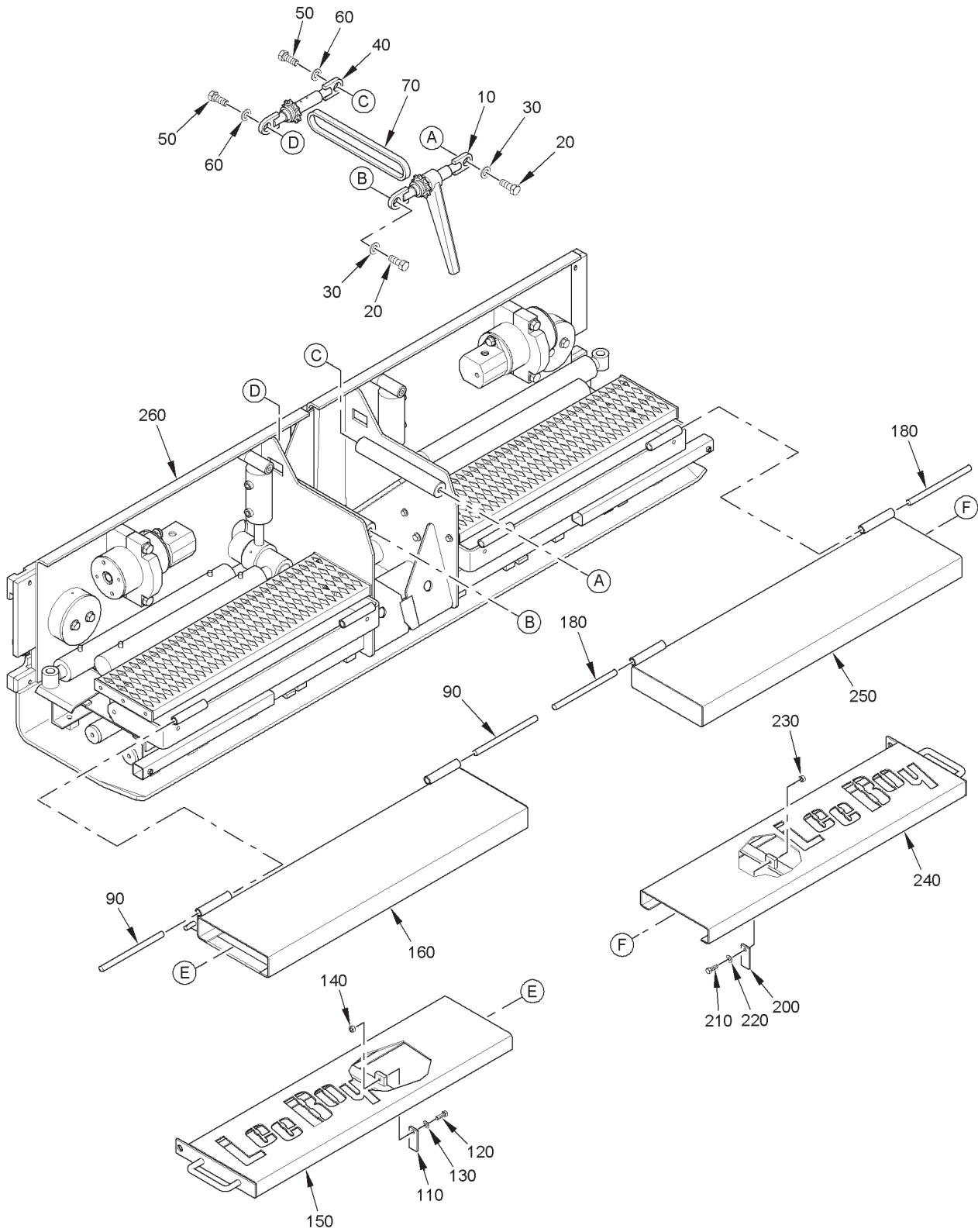

FIGURE 10. WALKBOARD & CROWN ADJUSTMENT REMOVAL

FIGURE 10. WALKBOARD & CROWN ADJUSTMENT REMOVAL

FIG ITEM	PART NUMBER	NOMENCLATURE							UNITS PER ASSY
		1	2	3	4	5	6	7	
10									
-1	9NONUMBER110	WALKBOARD & CROWN ADJUSTMENT REMOVAL							REF
10	983157	• TURNBUCKLE ASSEMBLY, WITH RATCHET							1
		ATTACHING PARTS							
20	102-709-1A	• CAPSCREW, 3/4" - 10 X 2.0 HEX							2
30	119-8	• FLAT WASHER, 3/4" SAE							2
		-----*-----							
40	980182	• CROWN AND VALLEY ADJUSTMENT ASSEMBLY							1
		ATTACHING PARTS							
50	102-709-1A	• CAPSCREW, 3/4" - 10 X 2.0 HEX							2
60	119-8	• FLAT WASHER, 3/4" SAE							2
		-----*-----							
70	981020	• CHAIN							1
-80	980426L	• WALKBOARD ASSEMBLY, LH COMPLETE							1
		ATTACHING PARTS							
90	980427	• HINGE PIN, WALKBOARD							2
		-----*-----							
-100	856743L	•• WALKBOARD EXTENSION ASSEMBLY, LH							1
110	856742	••• PLATE, STOP							1
		ATTACHING PARTS							
120	102-306-1A	••• CAPSCREW, 7/16" - 14 X 1.25 HEX							1
130	119-4	••• FLAT WASHER, 7/16" SAE							1
140	116-4	••• NUT, 7/16" - 14 HEX							1
		-----*-----							
150	856735L	••• WALKBOARD PLATE WELDMENT, LH							1

- ITEM NOT ILLUSTRATED

**This Page
Intentionally
Left Blank**

FIGURE 10. WALKBOARD & CROWN ADJUSTMENT REMOVAL (CONTINUED)

FIG ITEM	PART NUMBER	NOMENCLATURE							UNITS PER ASSY
		1	2	3	4	5	6	7	
10									
160	980425L	•• WALKBOARD EXTENSION WELDMENT, LH DECK							1
-170	980426R	• WALKBOARD ASSEMBLY, RH COMPLETE							1
		ATTACHING PARTS							
180	980427	• HINGE PIN, WALKBOARD							2
		-----*							
-190	856743R	•• WALKBOARD EXTENSION ASSEMBLY, RH							1
200	856742	••• PLATE, STOP							1
		ATTACHING PARTS							
210	102-306-1A	••• CAPSCREW, 7/16" - 14 X 1.25 HEX							1
220	119-4	••• FLAT WASHER, 7/16" SAE							1
230	116-4	••• NUT, 7/16" - 14 HEX							1
		-----*							
240	856735R	••• WALKBOARD PLATE WELDMENT, RH							1
250	980425R	•• WALKBOARD EXTENSION WELDMENT, RH DECK							1
260	10NONUMBER260	• FRAME ASSMEBLY							REF

- ITEM NOT ILLUSTRATED

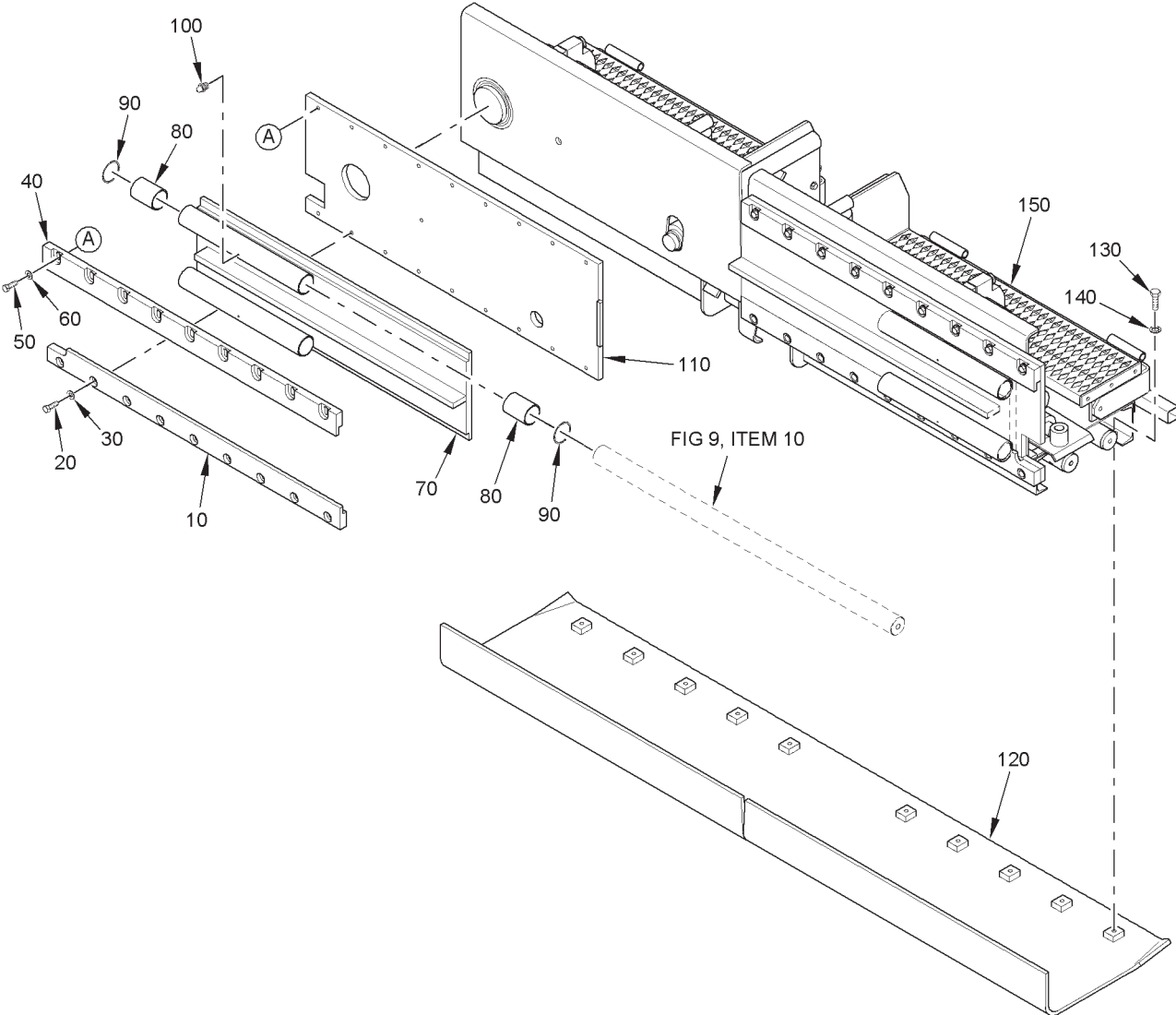

FIGURE 11. SLIDE ASSEMBLY, RH

FIGURE 11. SLIDE ASSEMBLY, RH

FIG ITEM	PART NUMBER	NOMENCLATURE							UNITS PER ASSY
		1	2	3	4	5	6	7	
11									
-1	10NONUMBER260	SLIDE ASSEMBLY, RH							REF
10	980244R	• BAR, RH EXTENSION RAIL							1
		ATTACHING PARTS							
20	102-407-1A	• CAPSCREW, 1/2" - 13 X 1.5 HEX							9
30	119-5	• FLAT WASHER, 1/2" SAE							9
		-----*							
40	980259	• BAR, EXTENSION RAIL							1
		ATTACHING PARTS							
50	102-407-1A	• CAPSCREW, 1/2" - 13 X 1.5 HEX							9
60	119-5	• FLAT WASHER, 1/2" SAE							9
		-----*							
70	980225	• SLIDE ASSEMBLY, EXTENSION							1
80	980360	• BUSHING, SLIDE							4
		ATTACHING PARTS							
90	980380	• SNAP RING							1
		-----*							
100	140610	• GREASE FITTING 1/4" - 28 SCREW							2
110	980243	• PLATE, SIDE MOUNT							1
120	980209	• PLATE ASSEMBLY, MAIN WEAR, 8816							1
		ATTACHING PARTS							
130	102-304-1A	• CAPSCREW, 7/16" - 14 X 0.75 HEX							10
140	119-4	• FLAT WASHER, 7/16" SAE							10
		-----*							
150	11NONUMBER150	• FRAME ASSEMBLY							REF

ILLUSTRATED PARTS LIST

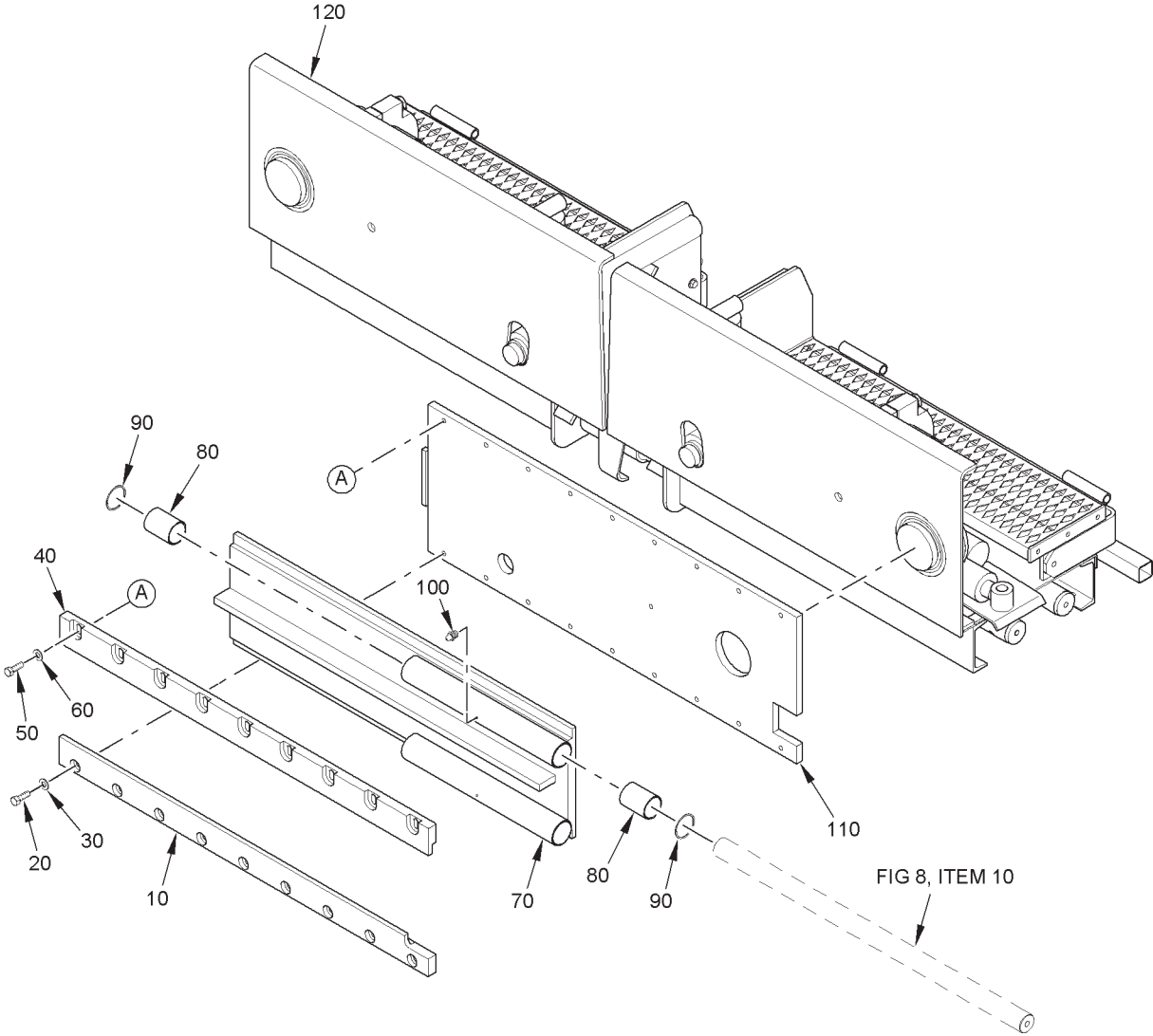

FIGURE 12. SLIDE ASSEMBLY, LH

FIGURE 12. SLIDE ASSEMBLY, LH

FIG ITEM	PART NUMBER	NOMENCLATURE							UNITS PER ASSY
		1	2	3	4	5	6	7	
12									
-1	11NONUMBER150	SLIDE ASSEMBLY, LH							REF
10	980244L	• BAR, LH EXTENSION RAIL							1
		ATTACHING PARTS							
20	102-407-1A	• CAPSCREW, 1/2" - 13 X 1.5 HEX							9
30	119-5	• FLAT WASHER, 1/2" SAE							9
		-----*							
40	980259	• BAR, EXTENSION RAIL							1
		ATTACHING PARTS							
50	102-407-1A	• CAPSCREW, 1/2" - 13 X 1.5 HEX							9
60	119-5	• FLAT WASHER, 1/2" SAE							9
		-----*							
70	980225	• SLIDE ASSEMBLY, EXTENSION							1
80	980360	• • BUSHING, SLIDE							4
		ATTACHING PARTS							
90	980380	• • SNAP RING							1
		-----*							
100	140610	• • GREASE FITTING 1/4" - 28 SCREW							2
110	980243	• PLATE, SIDE MOUNT							1
120	12NONUMBER120	• FRAME ASSEMBLY							REF

ILLUSTRATED PARTS LIST

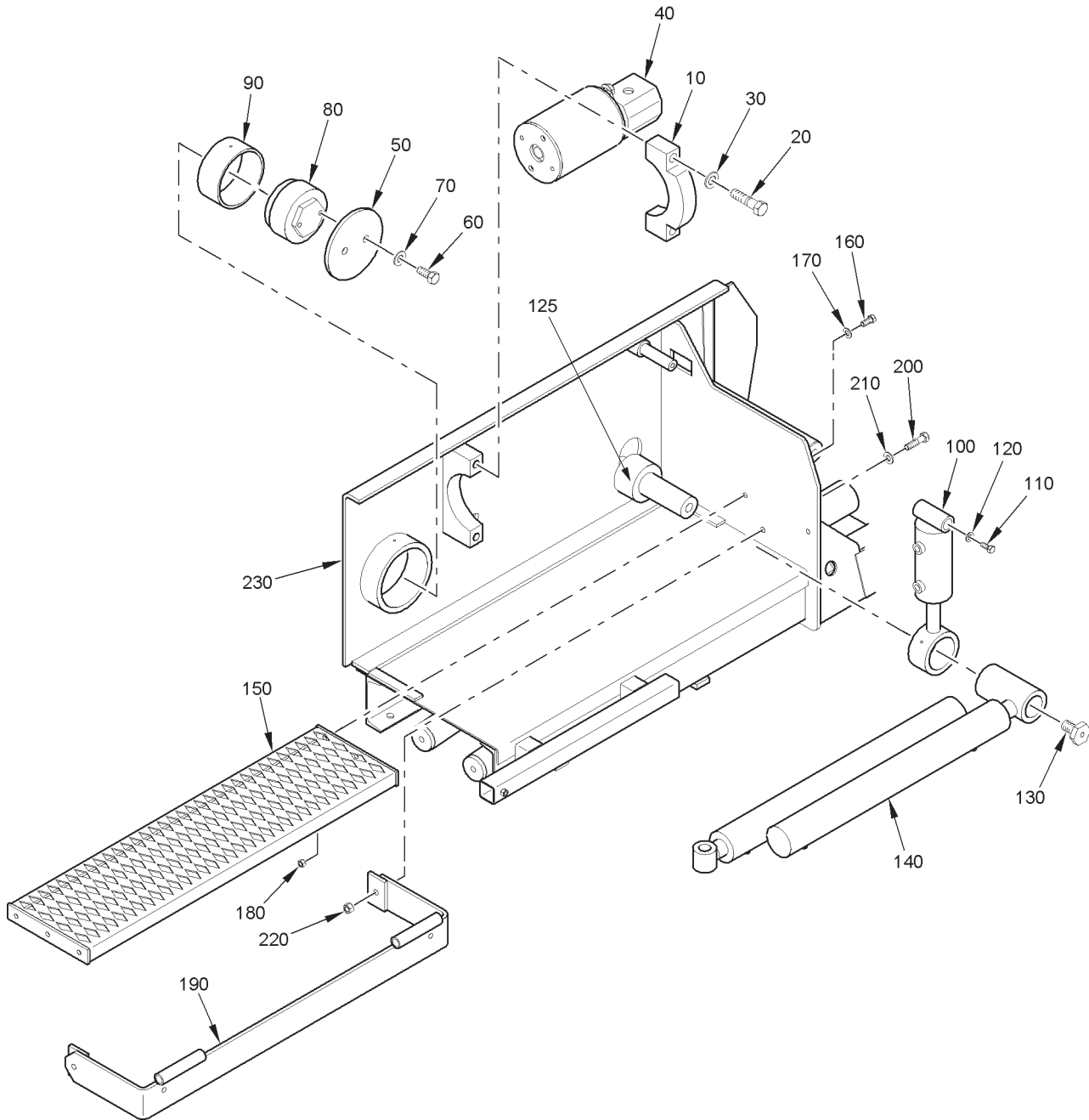

FIGURE 13. VIBRATOR REMOVAL, LH

FIGURE 13. VIBRATOR REMOVAL, LH

FIG ITEM	PART NUMBER	NOMENCLATURE							UNITS PER ASSY
		1	2	3	4	5	6	7	
13									
-1	12NONUMBER120	VIBRATOR REMOVAL, LH							REF
10	980416	• CLAMP							1
		ATTACHING PARTS							
20	102-713-1A	• CAPSCREW, 3/4" - 10 X 3.0 HEX							2
30	119-8	• FLAT WASHER, 3/4" SAE							2
		-----*							
40	854662	• VIBRATOR ASSEMBLY, SCREED (SEE FIG 19 FOR BREAKDOWN)							1
50	980254	• COVER PLATE, PIVOT							1
		ATTACHING PARTS							
60	102-607-1A	• CAPSCREW, 5/8" - 11 X 1.5 HEX							2
70	119-7	• FLAT WASHER, 5/8" SAE							2
		-----*							
80	980232	• BAR, PIVOT							1
90	980370	• BUSHING, PIVOT MOUNT							1
100	980420	• HYDRAULIC CYLINDER, SCREED SLOPE							1
-102	981050-01	• SEAL KIT							1
		ATTACHING PARTS							
110	102-307-1A	• CAPSCREW, 7/16" - 14 X 1.5 HEX							1
120	119-4	• FLAT WASHER, 7/16" SAE							1
125	980256	SHAFT, CYLINDER MOUNT							1
		-----*							
130	980256	• END CAP, CYLINDER MOUNT SHAFT							1
140	981050	• HYDRAULIC CYLINDER, SCREED EXTENSION LH							1
-142	981050-01	• SEAL KIT							1

**This Page
Intentionally
Left Blank**

FIGURE 13. VIBRATOR REMOVAL, LH (CONTINUED)

FIG ITEM	PART NUMBER	NOMENCLATURE							UNITS PER ASSY
		1	2	3	4	5	6	7	
13									
150	980428	• WALKBOARD, LID COVER							1
		ATTACHING PARTS							
160	102-307-1A	• CAPSCREW, 7/16" - 14 X 1.5 HEX							2
170	119-4	• FLAT WASHER, 7/16" SAE							2
180	116-4	• NUT, 7/16" - 14 HEX							2
		-----*							
190	980424	• BAR, WALKBOARD, HINGE MOUNT							1
		ATTACHING PARTS							
200	102-409-1A	• CAPSCREW, 1/2" - 13 X 2.0 HEX							1
210	119-5	• FLAT WASHER, 1/2" SAE							1
220	116-5	• NUT, 1/2" - 13 HEX							1
		-----*							
230	13NONUMBER230	• FRAME ASSEMBLY							REF

ILLUSTRATED PARTS LIST

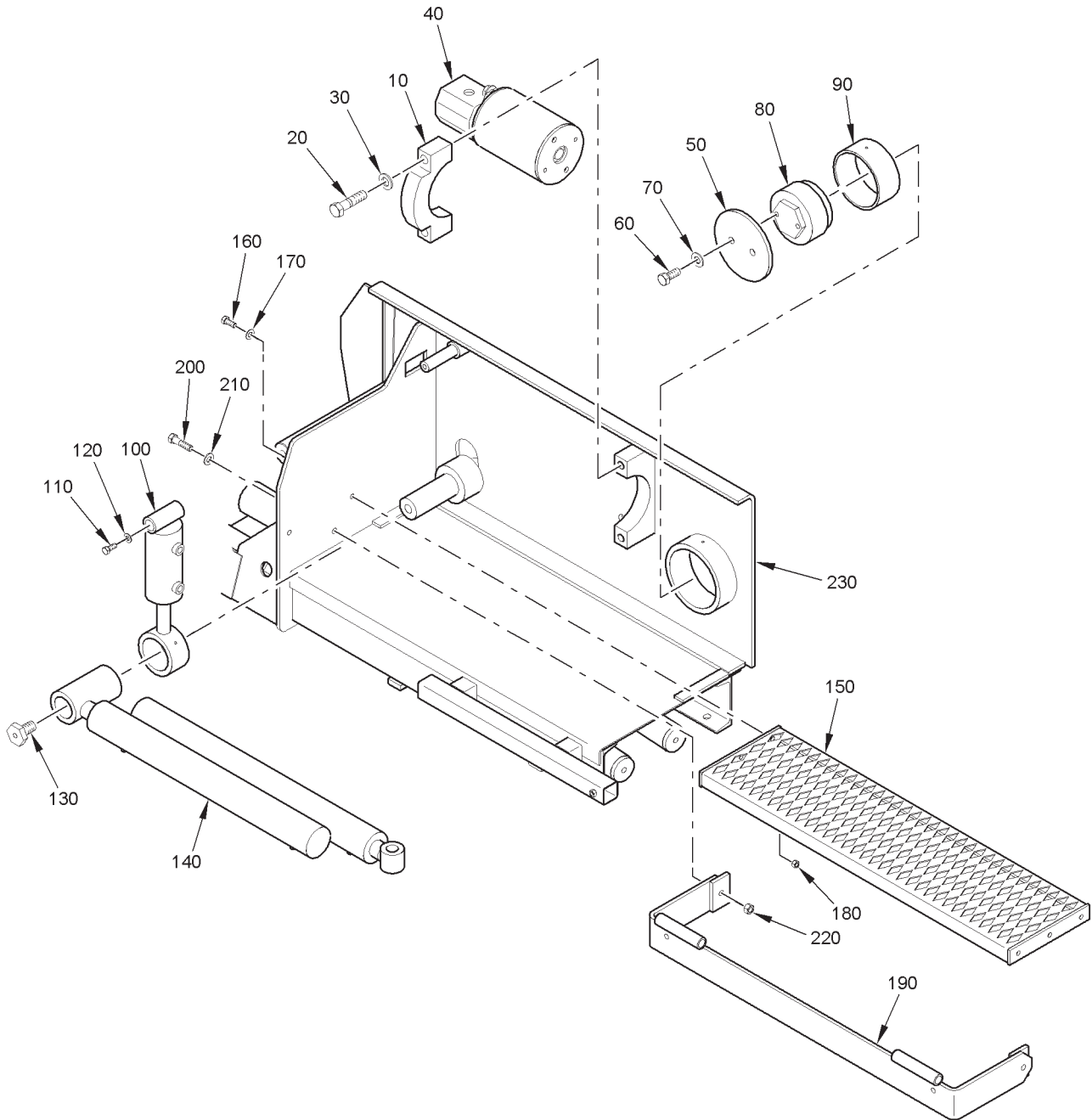

FIGURE 14. VIBRATOR REMOVAL, RH

FIGURE 14. VIBRATOR REMOVAL, RH

FIG ITEM	PART NUMBER	NOMENCLATURE							UNITS PER ASSY
		1	2	3	4	5	6	7	
14									
-1	13NONUMBER230	VIBRATOR REMOVAL, RH							REF
10	980416	• CLAMP							1
		ATTACHING PARTS							
20	102-713-1A	• CAPSCREW, 3/4" - 10 X 3.0 HEX							2
30	119-8	• FLAT WASHER, 3/4" SAE							2
		-----*							
40	854662	• VIBRATOR ASSEMBLY, SCREED							1
50	980254	• COVER PLATE, PIVOT							1
		ATTACHING PARTS							
60	102-607-1A	• CAPSCREW, 5/8" - 11 X 1.5 HEX							2
70	119-7	• FLAT WASHER, 5/8" SAE							2
		-----*							
80	980232	• BAR, PIVOT							1
90	980370	• BUSHING, PIVOT MOUNT							1
100	980420	• HYDRAULIC CYLINDER, SCREED SLOPE							1
-102	980420-01	• SEAL KIT							1
		ATTACHING PARTS							
110	102-307-1A	• CAPSCREW, 7/16" - 14 X 1.5 HEX							1
120	119-4	• FLAT WASHER, 7/16" SAE							1
		-----*							
130	980256	• END CAP, CYLINDER MOUNT SHAFT							1
140	980430	• HYDRAULIC CYLINDER, SCREED EXTENSION RH							1
-142	981050-01	• SEAL KIT							1

**This Page
Intentionally
Left Blank**

FIGURE 14. VIBRATOR REMOVAL, RH (CONTINUED)

FIG ITEM	PART NUMBER	NOMENCLATURE							UNITS PER ASSY
		1	2	3	4	5	6	7	
14									
150	980428	• WALKBOARD, LID COVER							1
		ATTACHING PARTS							
160	102-307-1A	• CAPSCREW, 7/16" - 14 X 1.5 HEX							2
170	119-4	• FLAT WASHER, 7/16" SAE							2
180	116-4	• NUT, 7/16" - 14 HEX							2
		-----*							
190	980424	• BAR, WALKBOARD, HINGE MOUNT							1
		ATTACHING PARTS							
200	102-409-1A	• CAPSCREW, 1/2" - 13 X 2.0 HEX							1
210	119-5	• FLAT WASHER, 1/2" SAE							1
220	116-5	• NUT, 1/2" - 13 HEX							1
		-----*							
230	14NONUMBER230	• FRAME ASSEMBLY							REF

ILLUSTRATED PARTS LIST

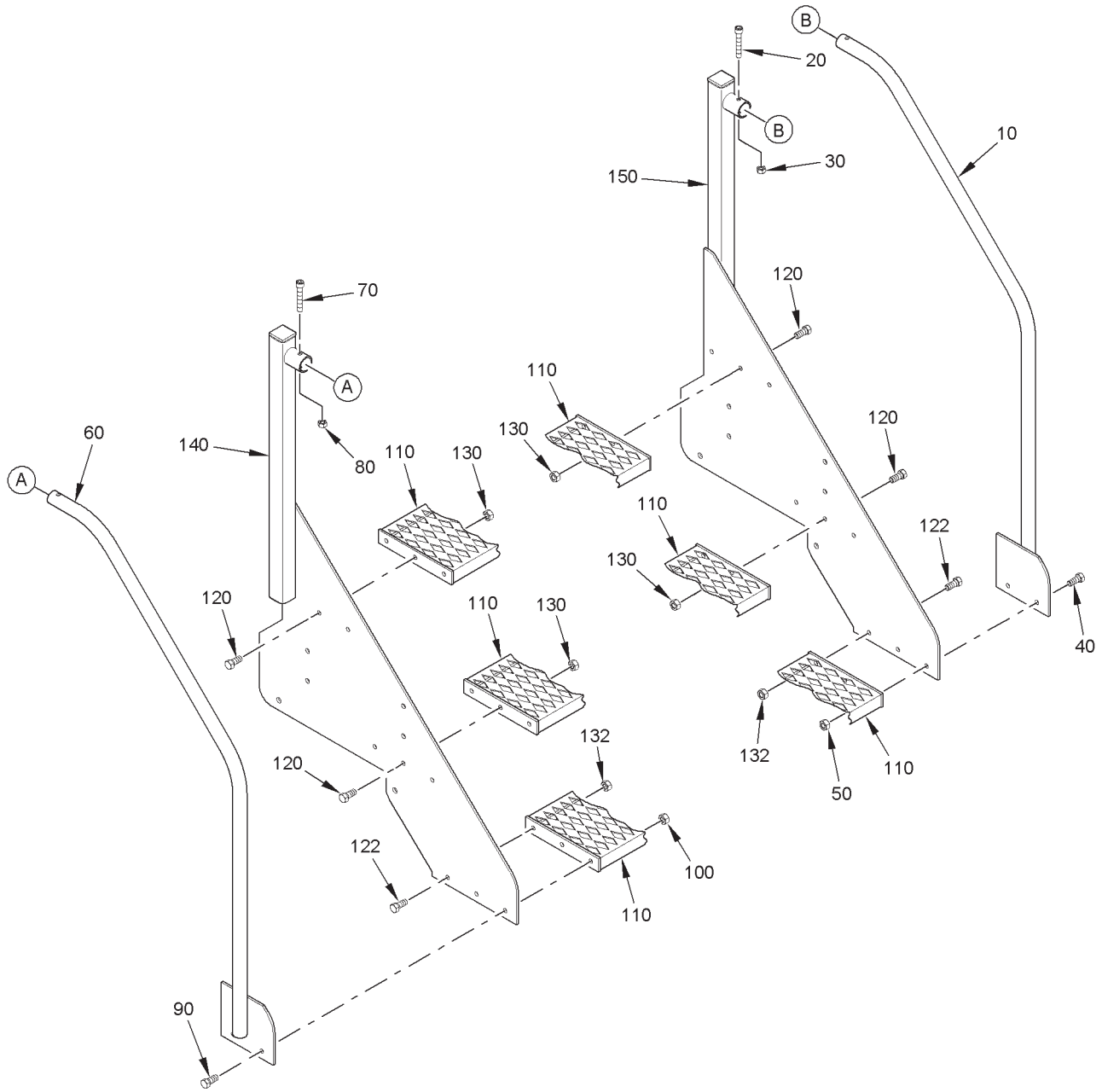

FIGURE 15. STAIRWAY ASSEMBLY

FIGURE 15. STAIRWAY ASSEMBLY

FIG ITEM	PART NUMBER	NOMENCLATURE							UNITS PER ASSY
		1	2	3	4	5	6	7	
15									
-1	980444	STAIRWAY ASSEMBLY (SEE FIG 1 FOR NHA)							REF
10	984407	• HAND RAIL ASSEMBLY, RH							1
		ATTACHING PARTS							
20	102-210-1A	• CAPSCREW, 3/8" - 16 X 2.25 HEX							1
30	116-3	• NUT, 3/8" - 16 HEX							1
40	102-305-1A	• CAPSCREW, 7/16" - 14 X 1.0 HEX							2
50	116-4	• NUT, 7/16" - 14 HEX							2
		-----*-----							
60	984406	• HAND RAIL ASSEMBLY, LH							1
		ATTACHING PARTS							
70	102-210-1A	• CAPSCREW, 3/8" - 16 X 2.25 HEX							1
80	116-3	• NUT, 3/8" - 16 HEX							1
90	102-305-1A	• CAPSCREW, 7/16" - 14 X 1.0 HEX							2
100	116-4	• NUT, 7/16" - 14 HEX							2
		-----*-----							
110	980452	• WALKBOARD ASSEMBLY, STAIRWAY							3
		ATTACHING PARTS							
120	102-305-1A	• CAPSCREW, 7/16" - 14 X 1.0 HEX							6
122	102-305-1A	• CAPSCREW, 7/16" - 14 X 1.0 HEX							2
130	116-4	• NUT, 7/16" - 14 HEX							6
132	116-4	• NUT, 7/16" - 14 HEX							2
		-----*-----							
140	984408	• STEP ASSEMBLY, LH SIDE							1
150	984409	• STEP ASSEMBLY, RH SIDE							1

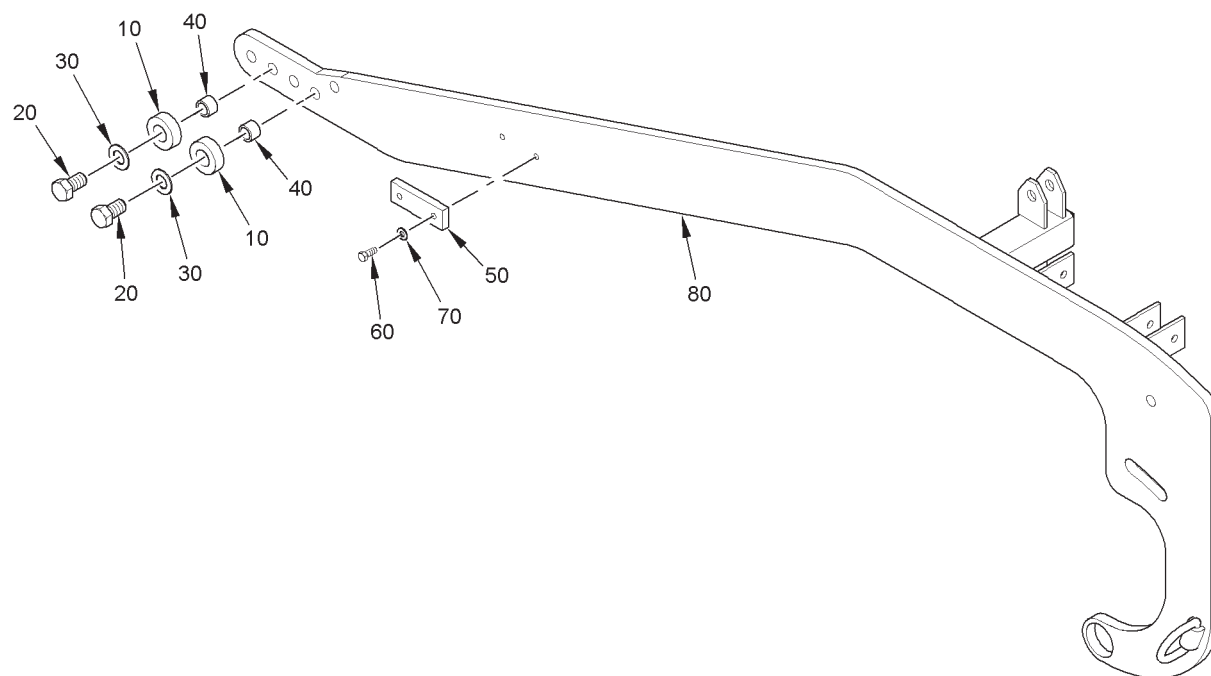

FIGURE 16. SCREED ARM ASSEMBLY

FIGURE 16. SCREED ARM ASSEMBLY

FIG ITEM	PART NUMBER	NOMENCLATURE							UNITS PER ASSY
		1	2	3	4	5	6	7	
16									
-1	980341	SCREED ARM ASSEMBLY (SEE FIG 5 FOR NHA)							REF
10	980439	• STOP BAR, SCREED ARM							2
		ATTACHING PARTS							
20	102-909-1A	• CAPSCREW, 1.0" - 8 X 2.0 HEX							1
30	120-10	• FLAT WASHER, 1.0" SAE							1
		-----*							
40	980441	• STOP TUBE, ARM INNER ROLLER							2
50	855568	• PLATE, TAPPED							1
		ATTACHING PARTS							
60	102-406-1A	• CAPSCREW, 1/2" - 13 X 1.25 HEX							2
70	119-5	• FLAT WASHER, 1/2" SAE							2
		-----*							
80	981503	• CYLINDER, HYD.							1
82	240030	• PIN, CLEVIS							2
84	81019	• PIN, COTTER							2
-86	851484	• SEAL KIT							1
100	980393L	• SCREED ARM WELDMENT, LH							1
-110	980393R	• SCREED ARM WELDMENT, RH							1

- ITEM NOT ILLUSTRATED

ILLUSTRATED PARTS LIST

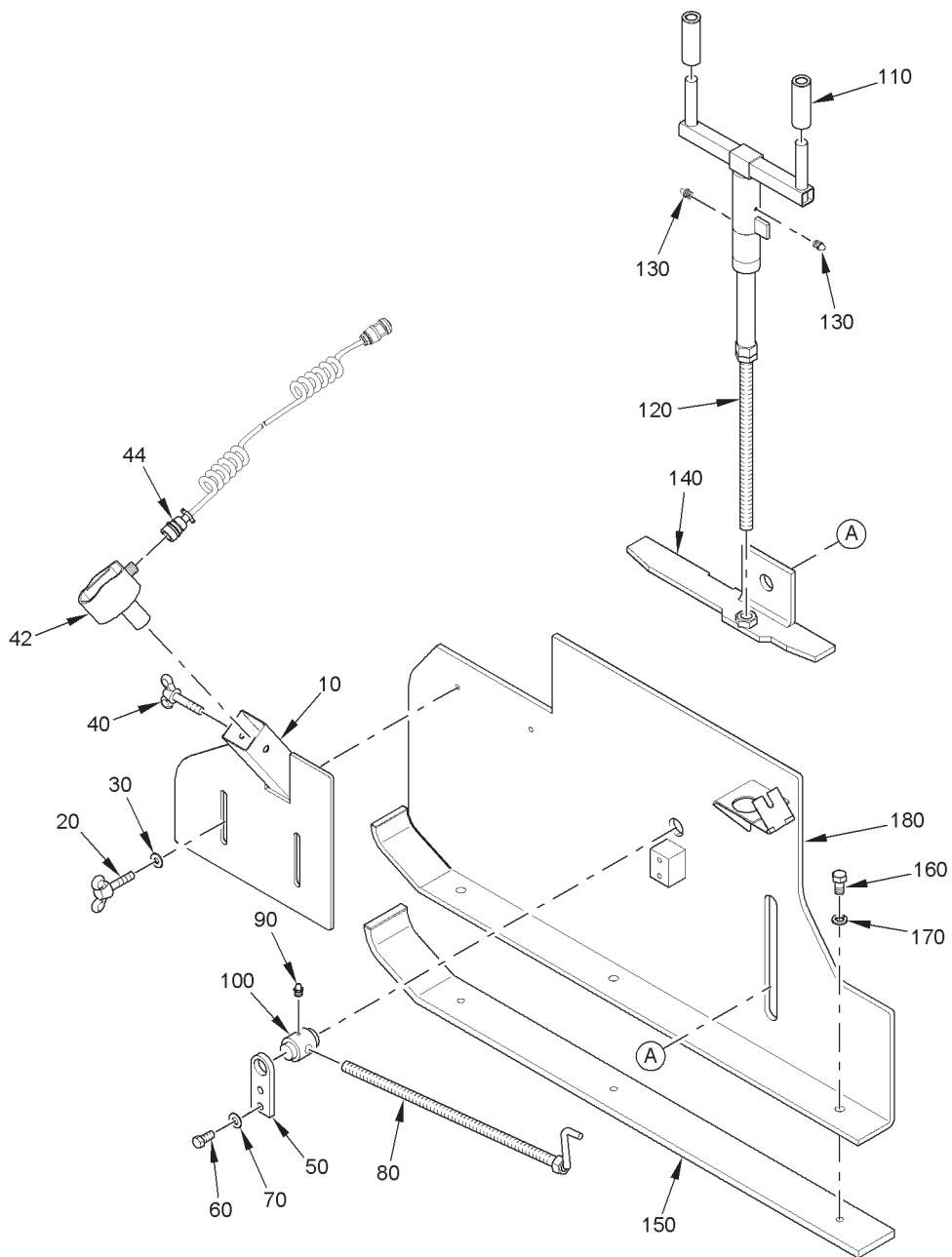

FIGURE 17. END GATE ASSEMBLY

FIGURE 17. END GATE ASSEMBLY

FIG ITEM	PART NUMBER	NOMENCLATURE							UNITS PER ASSY
		1	2	3	4	5	6	7	
17									
-1	980456L	END GATE ASSEMBLY (SEE FIG 6 FOR NHA)							REF
-2	980456R	END GATE ASSEMBLY (SEE FIG 6 FOR NHA)							REF
10	984287	• MOUNT ASSEMBLY, SONIC AUGER, LH							1
-11	984288	• MOUNT ASSEMBLY, SONIC AUGER, RH							1
		ATTACHING PARTS							
20	920070	• WING BOLT, 3/8"-11 X 2.0							2
30	930019	• WASHER, FLAT, 3/8" SAE							2
		-----*-----							
40	920070	• WING BOLT, 3/8"-11 X 2.0							1
42	980540	• SONIC AUGER SENSOR							2
44	980550	• SONIC AUGER CORD							2
50	980458	• BAR, TILT SCREW HOLDDOWN							1
		ATTACHING PARTS							
60	102-305-1A	• SCREW, HEX, 7-16-14 X 1"							
70	119-4	• WASHER, FLAT, 7/16" SAE							
		-----*-----							
80	981099	• TILT SCREW							1
90	140610	• GREASE FITTING, 1/4-28							1
100	980457	• SHAFT, TILT SCREW SWIVEL							1
110	870276	• HAND GRIP, FLIGHT/DEPTH SCREW							2
120	983515	• SCREW ASSEMBLY, DEPTH							1
130	140610	• GREASE FITTING, 1/4-28							2
140	855262L	• BOTTOM BRACKET, LH SCREW							1
-141	855262R	• BOTTOM BRACKET, RH SCREW							1
150	980466	• BOTTOM BAR, END GATE							1
		ATTACHING PARTS							
160	102-405-1A	• SCREW, HEX CAP, 1/2-13 X 1"							3
170	118-5	• WASHER, LOCK, 1/2"							3
		-----*-----							
180	17NONUMBER180	• GATE WELDMENT							

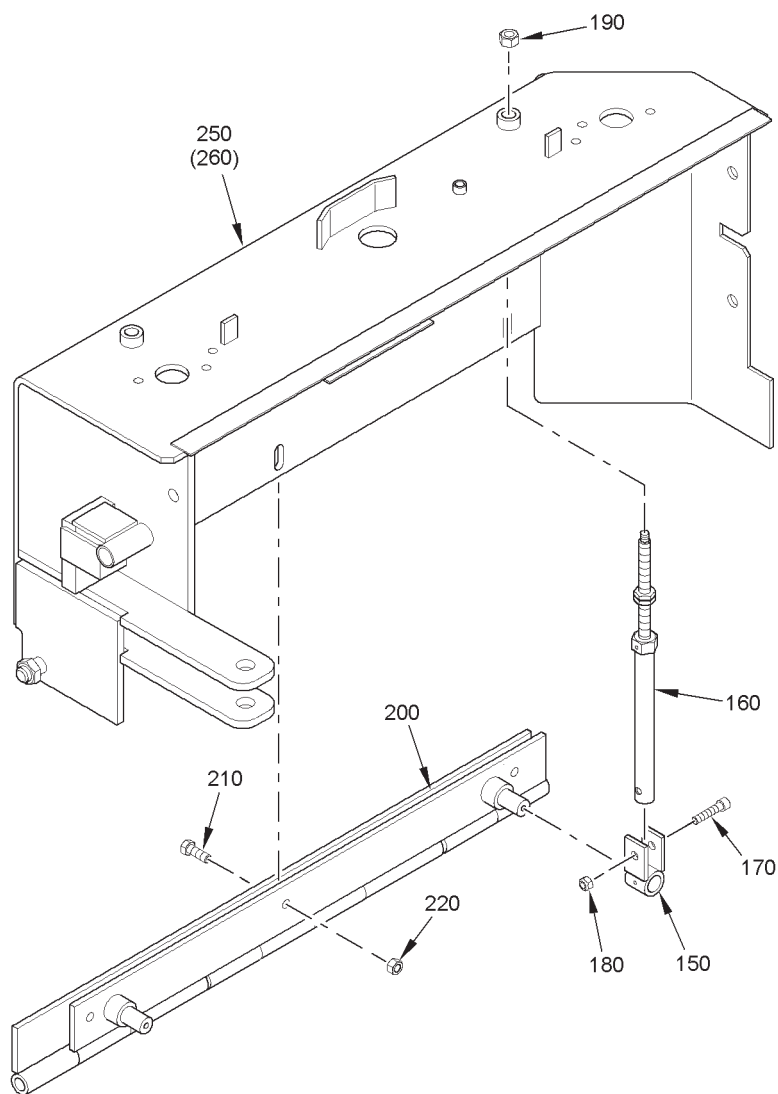

FIGURE 18. EXTENSION ASSEMBLY (Sheet 1 of 2)

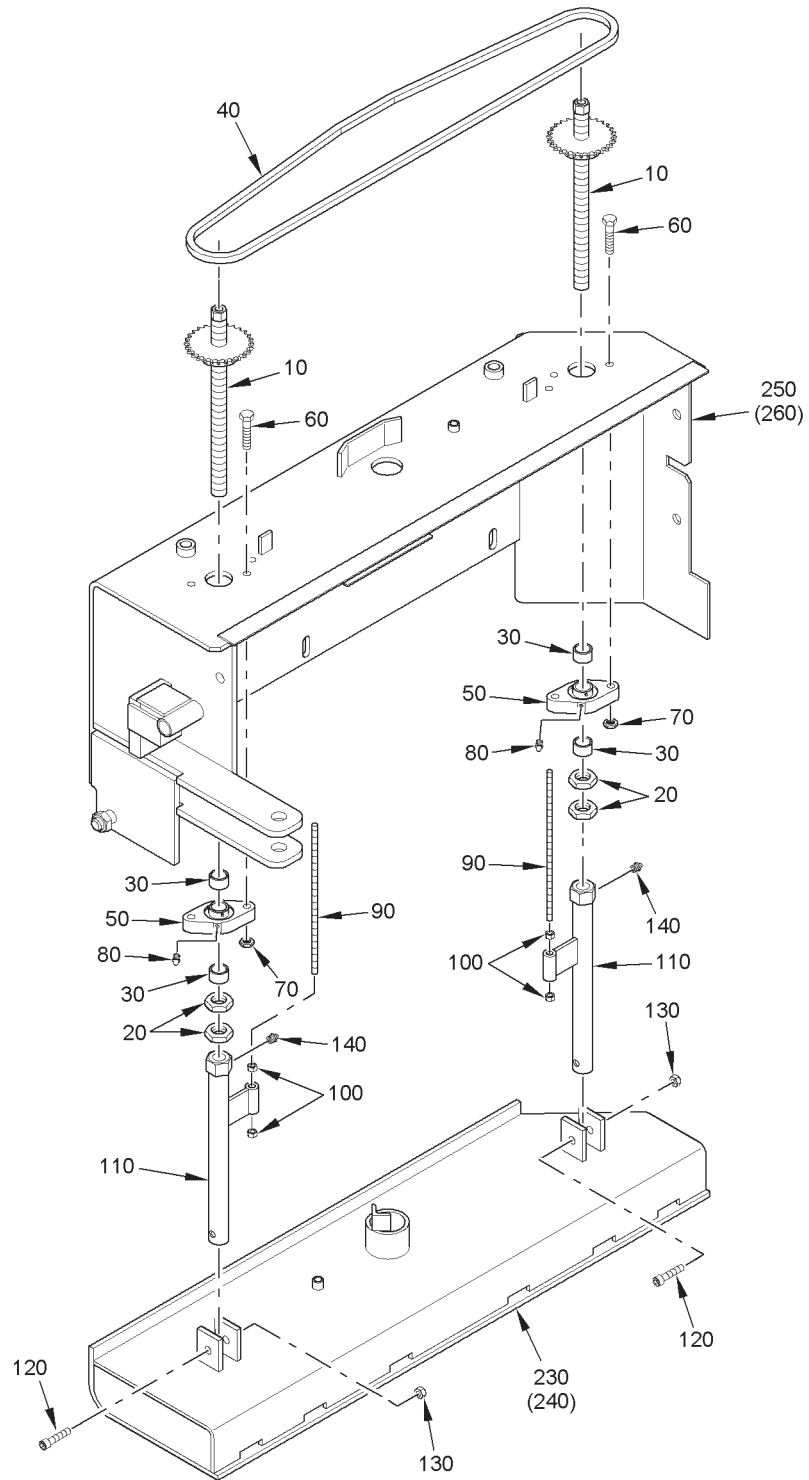

FIGURE 18. EXTENSION ASSEMBLY (Sheet 2 of 2)

**This Page
Intentionally
Left Blank**

FIGURE 18. EXTENSION ASSEMBLY

FIG ITEM	PART NUMBER	NOMENCLATURE							UNITS PER ASSY
		1	2	3	4	5	6	7	
18									
-1	980233L	EXTENSION ASSEMBLY LH (SEE FIG 8 FOR NHA)							REF
-2	980233R	• EXTENSION ASSEMBLY RH (SEE FIG 9 FOR NHA)							REF
10	980261-01	• ADJUSTER ASSEMBLY, UPPER TILT							2
20	116-10-1	• NUT, JAM, 1"-8							4
30	851186	• SPACER							4
40	981030	• CHAIN, #40R164							1
50	870030	• BEARING BLOCK							2
		ATTACHING PARTS							
60	102-310-1A	• SCREW, HEX HEAD CAP, 7/16"-14 X 2-1/4"							2
70	143-4	• NUT, SELF-LOCKING, 7/16"-14							2
		-----*-----							
80	140610	• GREASE FITTING, 1/4"-28							2
90	851372	• GAUGE ROD, FLIGHT SCREW LEVEL							2
		ATTACHING PARTS							
100	115-3	• NUT, HEX, 3/8"-24							2
		-----*-----							
110	984621	• ADJUSTER ASSEMBLY, LOWER TILT							2
		ATTACHING PARTS							
120	102-412-1A	• SCREW, HEX HEAD CAP, 1/2"-13 X 2-3/4"							1
130	143-5	• NUT, LOCK, 1/2"-13							1
		-----*-----							
140	140610	• GREASE FITTING, 1/4"-28							1
150	854047	• BUSHING, CURBER FLIGHT SCREW BOTTOM							1
160	981994	• ADJUSTER ASSEMBLY, EXTENSION							2

**This Page
Intentionally
Left Blank**

FIGURE 18. EXTENSION ASSEMBLY (CONTINUED)

FIG ITEM	PART NUMBER	NOMENCLATURE							UNITS PER ASSY
		1	2	3	4	5	6	7	
18									
		ATTACHING PARTS							
170	870279	• SHOULDER SCREW, SOCKET HEAD CAP, 3/8"-16							1
180	143-3	• NUT, LOCK, 3/8"-16							1
190	143-5	• NUT, LOCK, 1/2"-13							1
		-----*							
200	984576	• HINGE							1
		ATTACHING PARTS							
210	102-409-1A	• SCREW, HEX HEAD CAP, 1/2"-13 X 2							3
220	143-5	• NUT, LOCK, 1/2"-13							3
		-----*							
230	980235L	• BOTTOM ASSEMBLY, LEFT-HAND EXTENSION							1
-240	980235R	• BOTTOM ASSEMBLY, RIGHT-HAND EXTENSION							1
250	980233L	• EXTENSION ASSEMBLY, LEFT-HAND							1
-260	980233R	• EXTENSION ASSEMBLY, RIGHT-HAND							1

- ITEM NOT ILLUSTRATED

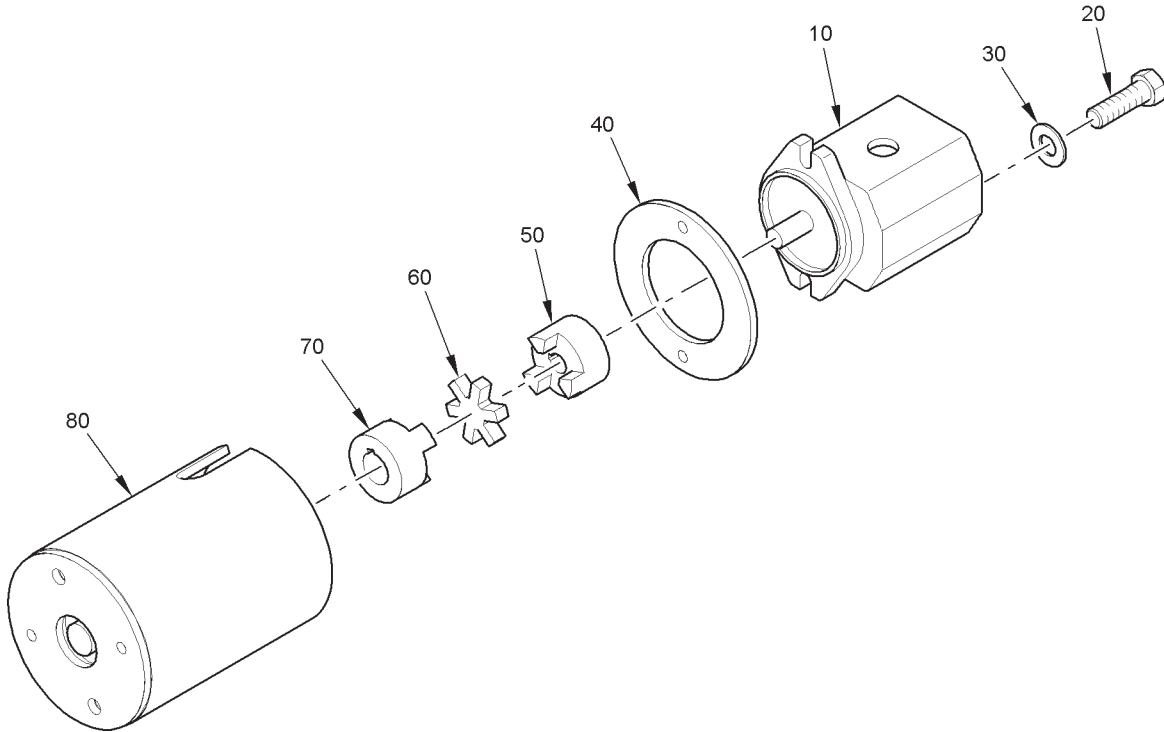

FIGURE 19. VIBRATOR ASSEMBLY

FIGURE 19. VIBRATOR ASSEMBLY

FIG ITEM	PART NUMBER	NOMENCLATURE							UNITS PER ASSY
		1	2	3	4	5	6	7	
19									
-1	854662	VIBRATOR ASSEMBLY (SEE FIG 13 FOR NHA)							REF
10	983405	• HYDRAULIC MOTOR, SCREED VIBRATOR.							1
		ATTACHING PARTS							
20	102-609-1A	• CAPSCREW, 5/8" - 11 X 2.0 HEX							2
30	118-7	• LOCK WASHER, 5/8" SAE							2
		-----*							
40	854667	• WELD RING, VIBRATOR MOTOR							1
50	280030	• COUPLING HALF, VIBRATOR/TACK PUMP							1
60	280040	• INSERT, 3-JAW COUPLING							1
70	880030	• COUPLING HALF, 1"							1
80	855535	• VIBRATOR							1

ILLUSTRATED PARTS LIST

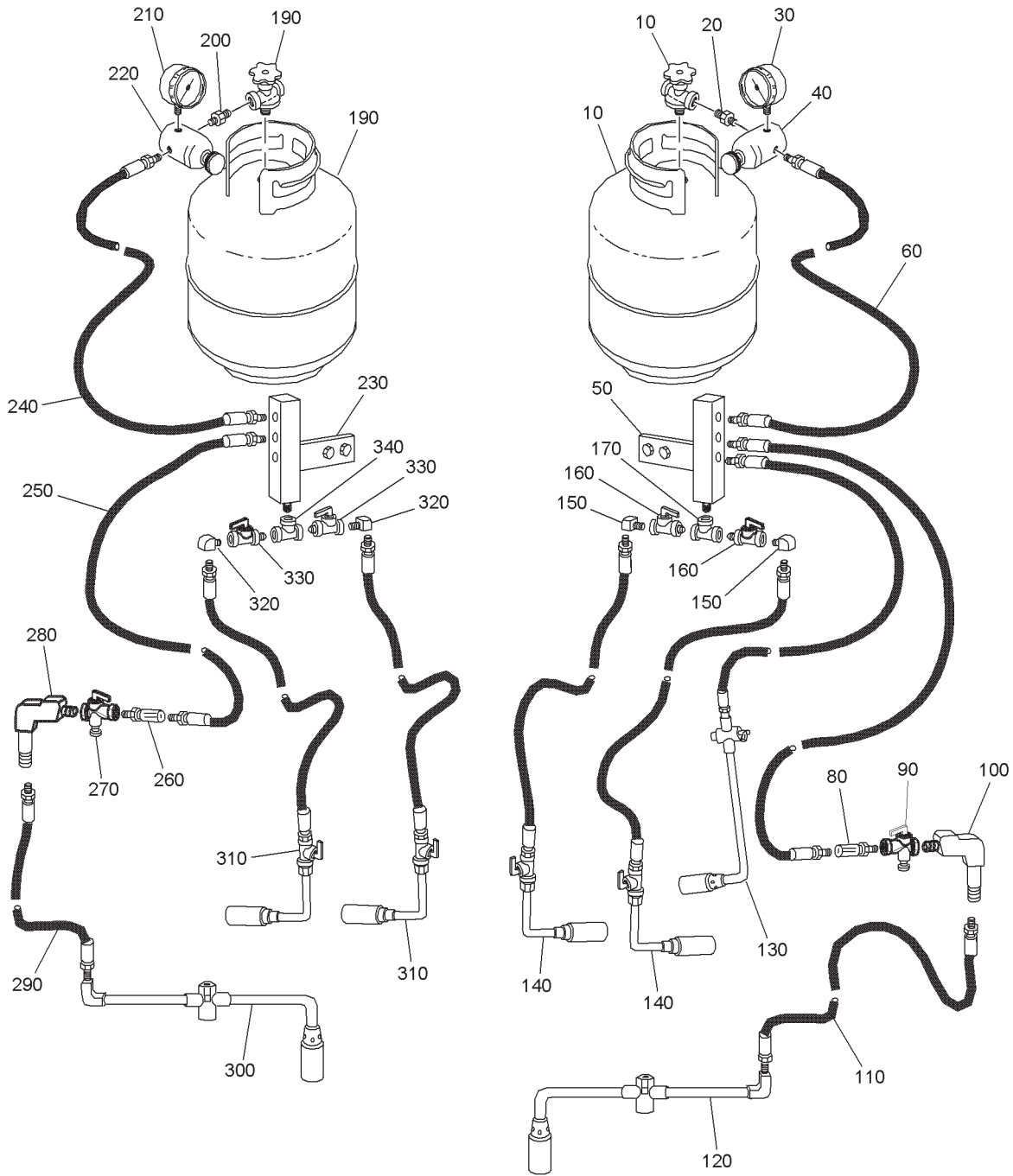

FIGURE 20. BURNER ASSEMBLY

FIGURE 20. BURNER ASSEMBLY

FIG ITEM	PART NUMBER	NOMENCLATURE							UNITS PER ASSY
		1	2	3	4	5	6	7	
20									
-1	TBD	BURNER ASSEMBLY, FOUR-WAND (SEE FIG 1 FOR NHA)							REF
10	230010	• TANK, L.P.G., 20 LBS. (INCLUDES SHUTOFF VALVE)							1
20	230030	• POL ADAPTER, LPG TANK							1
30	230110	• GAUGE, PRESSURE							1
40	982515	• REGULATOR, PRESSURE							1
50	550108	• BRACKET, BURNER							1
60	985108-22	• HOSE ASSEMBLY 22"							1
70	985108-53	• HOSE ASSEMBLY 53"							1
80	985109	• ELBOW, 90-DEGREE, 04FEM, 04JAC							1
90	248672	• TEE, 1/4" BRASS							1
100	230083	• ELBOW, 90-DEGREE							1
110	985108-48	• HOSE ASSEMBLY							1
120	230250	• ADAPTER							1
130	230070	• SHUTOFF VALVE, BRASS							1
140	237826	• ELBOW, 90-DEGREE							1
150	230950	• PIPE NIPPLE, 1/4 X 2							1
160	985109	• ELBOW, 90-DEGREE, 04FEM, 04JAC							1
170	985108-24	• HOSE ASSEMBLY 24"							1
180	983437	• BURNER WAND EXTENSION ASSEMBLY							1
190	851183	• QUICK DISCONNECT, 1/4" MALE							1
200	230170	• COUPLING, 1/4" PIPE BRASS							1
210	99609	• PIPE, NIPPLE 1/4" X 4							1
220	982502	• BURNER, ASSEMBLY IGNITER							1
221	985108-54	• HOSE ASSEMBLY 54"							1
230	982504	• BURNER, ASSEMBLY MAIN							1
231	985108-52	• HOSE ASSEMBLY 52"							1
240	982504	• BURNER, ASSEMBLY MAIN							1
241	985108-43.5	• HOSE ASSEMBLY 43-1/2"							1
250	2515508	• ELBOW, 90-DEGREE							2
260	230070	• SHUTOFF VALVE, BRASS							2
270	248672	• T-FITTING, FEMALE							1
280	230010	• TANK, L.P.G., 20 LBS. (INCLUDES SHUTOFF VALVE)							1

NP = NOT PROCURABLE

**This Page
Intentionally
Left Blank**

FIGURE 20. BURNER ASSEMBLY (CONTINUED)

FIG ITEM	PART NUMBER	NOMENCLATURE							UNITS PER ASSY
		1	2	3	4	5	6	7	
20									
290	230030	• POL ADAPTER, LPG TANK							1
300	230110	• GAUGE, PRESSURE							1
310	982515	• REGULATOR, PRESSURE							1
320	550108	• BRACKET, BURNER							1
330	985108-20	• HOSE ASSEMBLY 20"							1
340	985108-55	• HOSE ASSEMBLY 55"							1
350	985109	• ELBOW, 90-DEGREE, 04FEM, 04JAC							1
360	248672	• TEE, 1/4" BRASS							1
370	230083	• ELBOW, 90-DEGREE							1
380	985108-48	• HOSE ASSEMBLY							1
390	230250	• ADAPTER							1
400	230070	• SHUTOFF VALVE, BRASS							1
410	237826	• ELBOW, 90-DEGREE							1
420	230950	• PIPE NIPPLE, 1/4 X 2							1
430	985109	• ELBOW, 90-DEGREE, 04FEM, 04JAC							1
440	985108-24	• HOSE ASSEMBLY 24"							1
450	983437	• BURNER WAND							1
460	851183	• QUICK DISCONNECT, 1/4" MALE							1
470	230170	• COUPLING, 1/4" PIPE BRASS							1
480	99609	• PIPE, NIPPLE 1/4" X 4							1
490	982502	• BURNER, ASSEMBLY IGNITER							1
491	985108-54	• HOSE ASSEMBLY 54"							1
500	982504	• BURNER, ASSEMBLY MAIN							1
501	985108-52	• HOSE ASSEMBLY 52"							1
510	982504	• BURNER, ASSEMBLY MAIN							1
511	985108-43.5	• HOSE ASSEMBLY 43-1/2"							1
520	2515508	• ELBOW, 90-DEGREE							2
530	230070	• SHUTOFF VALVE, BRASS							2
540	248672	• T-FITTING, FEMALE							1

NP = NOT PROCURABLE

ILLUSTRATED PARTS LIST

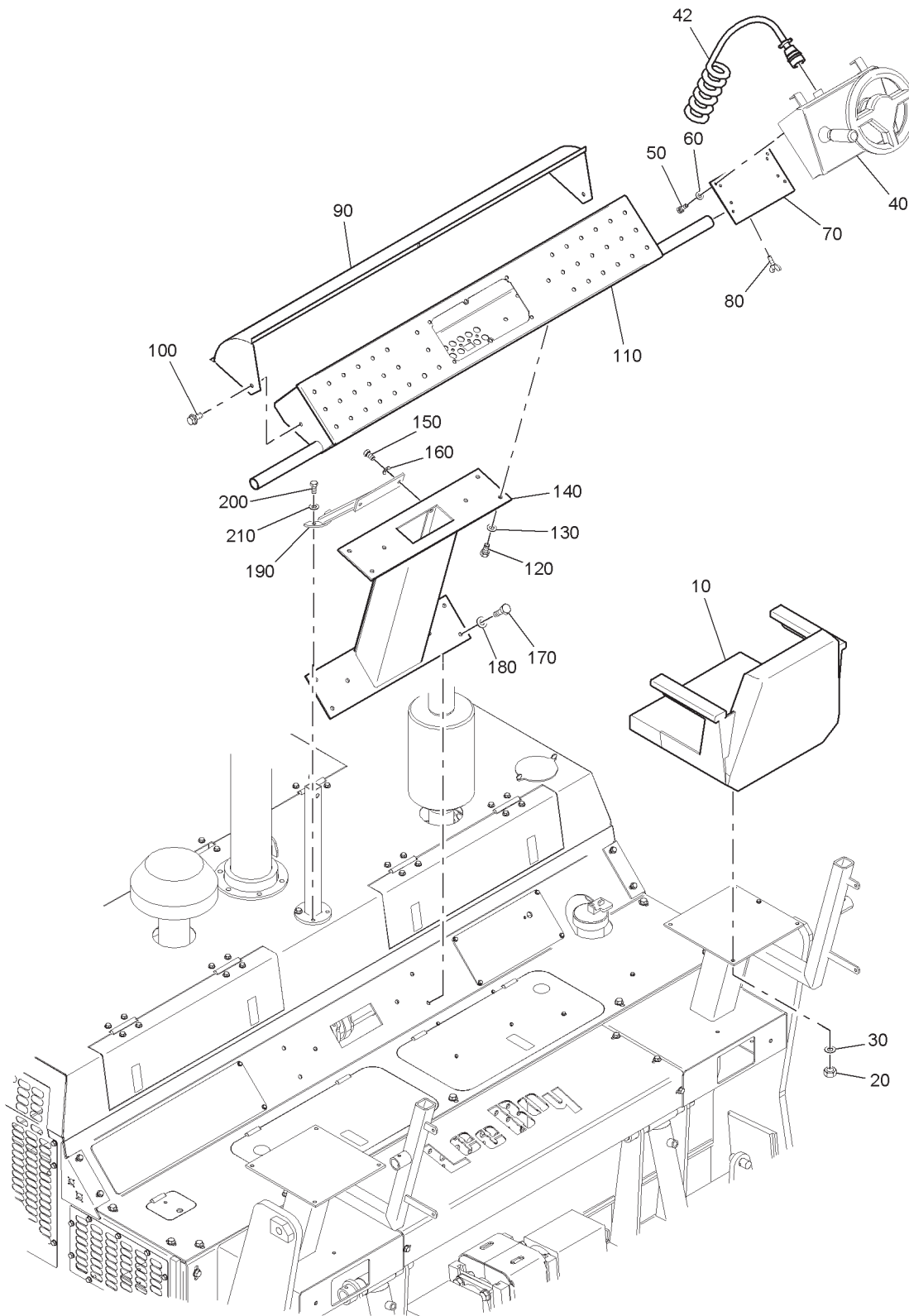

FIGURE 21. OPERATORS PLATFORM

FIGURE 21. OPERATORS PLATFORM

FIG ITEM	PART NUMBER	NOMENCLATURE							UNITS PER ASSY
		1	2	3	4	5	6	7	
21									
-1	TBD	OPERATOR'S PLATFORM							REF
10	360010	• SEAT ASSEMBLY, OPERATOR'S							2
		ATTACHING PARTS							
20	116-2	• NUT, 5/16" - 18 HEX							4
30	118-2	• LOCKWASHER, 5/16"							4
		-----*							
40	981913	• STEERING BOX, SUNDSTRAND WHEEL							2
42	851548	• COILED CORD, ELECTRONIC							2
		ATTACHING PARTS							
50	102-105-1A	• SCREW, 5/16" - 18 X 1.0 HEX CAP							4
60	119-2	• WASHER, 5/16" FLAT							4
		-----*							
70	980274	• STEERING MOUNT ASSEMBLY, ELECTRONIC							2
		ATTACHING PARTS							
80	920070	• WING BOLT							2
		-----*							
90	854632	• COVER ASSEMBLY, DASH VANDALISM							1
		ATTACHING PARTS							
100	102-409-1A	• SCREW, 1/2" - 13 X 1.0 HEX CAP							2
		-----*							
110	980333	• CONTROL BOX, 8816 DASH							1
-120	859766	• DECAL, 8816, DASH							1

NP = NOT PROCURABLE
 - ITEM NOT ILLUSTRATED

**This Page
Intentionally
Left Blank**

FIGURE 21. OPERATORS PLATFORM (CONTINUED)

FIG ITEM	PART NUMBER	NOMENCLATURE							UNITS PER ASSY
		1	2	3	4	5	6	7	
21									
		ATTACHING PARTS							
120	102-305-1A	• SCREW, 7/16" - 14 X 1.0 HEX CAP							6
130	119-4	• WASHER, 7/16" FLAT							6
		-----*							
140	980104	• SUPPORT ASSEMBLY, CONTROL DECK							1
		ATTACHING PARTS							
150	102-209-1A	• SCREW, 3/8" - 16 X 2.0 HEX CAP							2
160	119-3	• WASHER, 3/8" FLAT							2
170	102-408-1A	• SCREW, 1/2" - 13 X 1.75 HEX CAP							6
180	119-5	• WASHER, 1/2" FLAT							6
		-----*							
190	984971	• BRACE ASSEMBLY, DASH							1
		ATTACHING PARTS							
200	102-209-1A	• SCREW, 3/8" - 16 X 2.0 HEX CAP							2
210	119-3	• WASHER, 3/8" FLAT							2
		-----*							

NP = NOT PROCURABLE
 - ITEM NOT ILLUSTRATED

ILLUSTRATED PARTS LIST

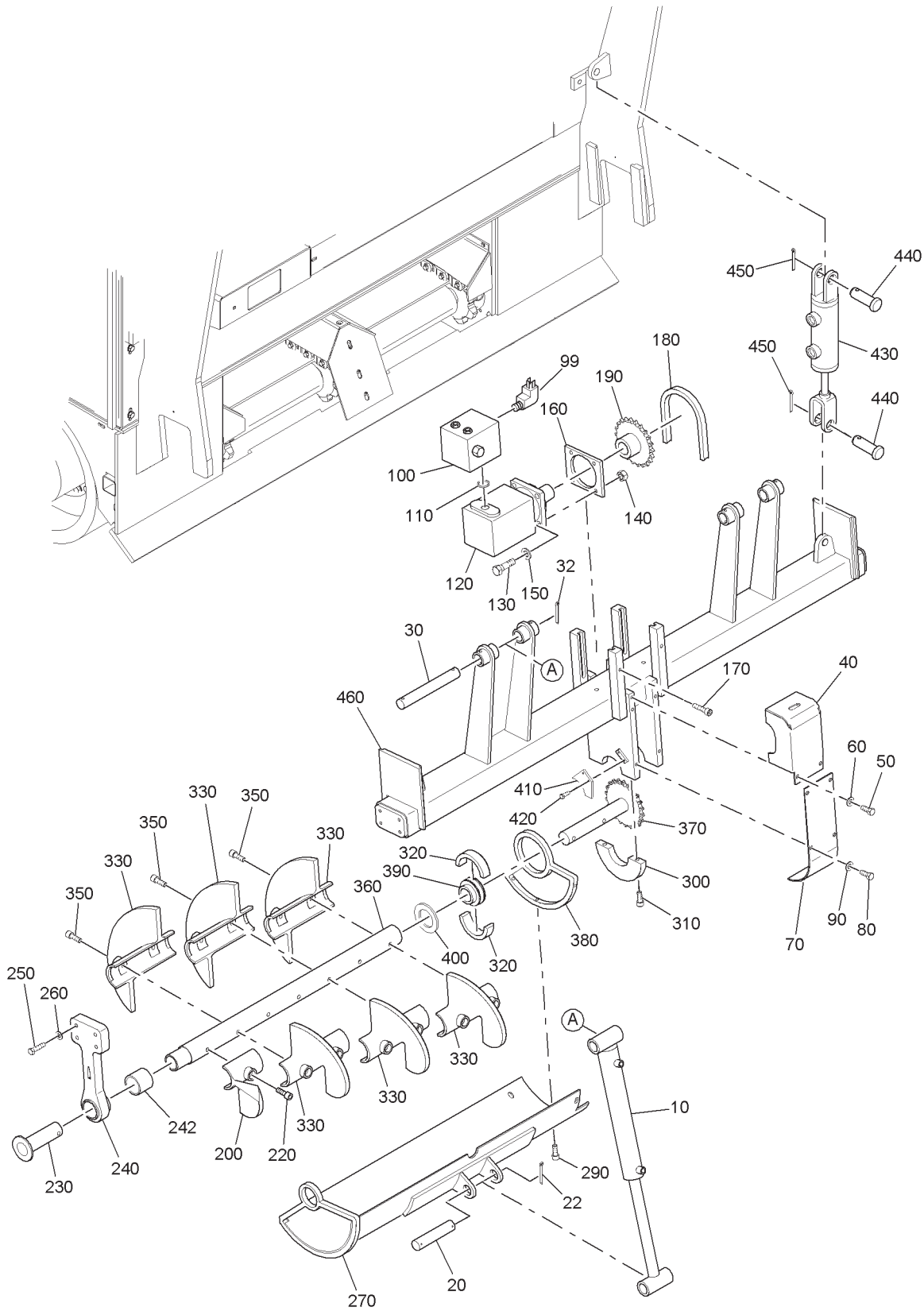

FIGURE 22. REAR AUGER ASSEMBLY

FIGURE 22. REAR AUGER ASSEMBLY

FIG ITEM	PART NUMBER	NOMENCLATURE							UNITS PER ASSY
		1	2	3	4	5	6	7	
22									
-1	TBD	REAR AUGER ASSEMBLY							REF
10	131090	• HYDRAULIC CYLINDER, 685 FRONT BLADE LIFT							2
-11	130050-1	• SEAL KIT							1
		ATTACHING PARTS							
20	980737	• PIN, CYLINDER							1
22	81019	• PIN, COTTER							2
30	858693	• PIN, CYLINDER							1
32	81019	• PIN, COTTER							2
		-----*							
40	980336	• COVER, AUGER CHAIN TOP							2
		ATTACHING PARTS							
50	102-409-1A	• SCREW, 1/2" - 13 X 2.0 HEX CAP							2
60	119-5	• WASHER, 1/2" FLAT							2
		-----*							
70	980128	• COVER, AUGER CHAIN BOTTOM							2
		ATTACHING PARTS							
80	102-409-1A	• SCREW, 1/2" - 13 X 2.0 HEX CAP							4
90	119-5	• WASHER, 1/2" FLAT							4
-97	980520-02	SEAL KIT							1
-98	980520-01	CARTRIDGE, VALVE							1
		-----*							
99	321330	• COIL ONLY							1
100	980520	• BLOCK							2
110	984994	• O-RING							2
120	980230	• HYDRAULIC MOTOR, 8816 AUGER DRIVE							2
		ATTACHING PARTS							
130	102-711-1A	• SCREW, 3/4" - 10 X 2.5 HEX CAP							4
140	116-8	• NUT, 3/4" - 10 HEX							4
150	119-8	• WASHER, 3/4" FLAT							4

NP = NOT PROCURABLE
- ITEM NOT ILLUSTRATED

NOTE: AUGER RH SIDE CONSISTS OF SIX 1/2 FLIGHTS PN980240 AND ONE BLANK OUTSIDE PN981742 AND ONE INSIDE FLIGHT PN980270.

ILLUSTRATED PARTS LIST



FIGURE 22. REAR AUGER ASSEMBLY (CONTINUED)

FIG ITEM	PART NUMBER	NOMENCLATURE							UNITS PER ASSY
		1	2	3	4	5	6	7	
22									
160	980127	• MOUNTING PLATE, MOTOR							2
		ATTACHING PARTS							
170	102-409-1A	• SCREW, 1/2" - 13 X 2.0 HEX CAP							2
		-----*							
180	851121	• DRIVE CHAIN, 8000C CONVEYOR							2
190	980188	• SPROCKET ASSEMBLY, AUGER DRIVE							2
-191	108-404-1A	• SCREW, 1/2" - 13 X 1", SET							2
200	980270	• QUARTER SECTION, LEFT-HAND AUGER FLIGHT							1
-210	980260	• QUARTER SECTION, RIGHT-HAND AUGER FLIGHT							1
-211	981742	• BLANK FLIGHT							3
		ATTACHING PARTS							
220	110-507-1A	• SCREW, 9/16" - 12 X 1.5 SOCKET HEAD CAP							1
		-----*							
230	980148	• SHAFT CAP, AUGER							2
240	980112	• SUPPORT, AUGER							2
242	980123	• BUSHING, AUGER HANGER							2
		ATTACHING PARTS							
250	102-409-1A	• SCREW, 1/2" - 13 X 2.0 HEX CAP							4
260	119-5	• WASHER, 1/2" FLAT							4
		-----*							
270	980138L	• CUTOFF ASSEMBLY, LEFT							1
-280	980138R	• CUTOFF ASSEMBLY, RIGHT							1
		ATTACHING PARTS							
290	102-305-1A	• SCREW, 7/16" - 14 X 1.0 HEX CAP							4
		-----*							

NP = NOT PROCURABLE
 - ITEM NOT ILLUSTRATED

FIGURE 22. REAR AUGER ASSEMBLY (CONTINUED)

FIG ITEM	PART NUMBER	NOMENCLATURE	UNITS PER ASSY
22			
300	980335	• BEARING SUPPORT, AUGER	2
		ATTACHING PARTS	
310	110-406-1A	• SCREW, 1/2" - 13 X 1.25 SOCKET HEAD CAP	2
		-----*-----	
320	980115	• PIVOT, CUTOFF	4
330	980250	• HALF-SECTION, LEFT-HAND AUGER FLIGHT	6
-340	980240	• HALF-SECTION, RIGHT-HAND AUGER FLIGHT	6
		ATTACHING PARTS	
350	110-419	• CAP SCREW, 1/2" - 13 X 4-1/2" SOCKET HEAD	2
-351	143-5	• LOCK NUT, 1/2" - 13 HEX	2
-352	980963	• WASHER, TEFLON	2
		-----*-----	
360	980121	• SHAFT, AUGER	2
370	980131	• SPROCKET ASSEMBLY, AUGER	2
380	980117	• CUTOFF ARM, INSIDE	2
390	420090	• BEARING, 400 FRONT AXLE/7000	2
400	984543	• WASHER, THRUST	2
410	984393	• STOP BRACKET, AUGER CUTOFF	2
		ATTACHING PARTS	
420	102-205-1A	• SCREW, 3/8" - 16 X 1.0 HEX CAP	2
		-----*-----	
430	981502	• CYLINDER, HYD	2
-432	870312	• SEAL KIT	1
440	240030	• PIN, CLEVIS	2
450	81019	• PIN, COTTER	2
460	980149	• AUGER ASSEMBLY, 8816	1

NP = NOT PROCURABLE
- ITEM NOT ILLUSTRATED

NOTE: AUGER LH SIDE CONSISTS OF SIX 1/2 FLIGHTS PN980250 AND ONE BLANK INSIDE PN981742 AND ONE BLANK OUTSIDE PN981742.

ILLUSTRATED PARTS LIST

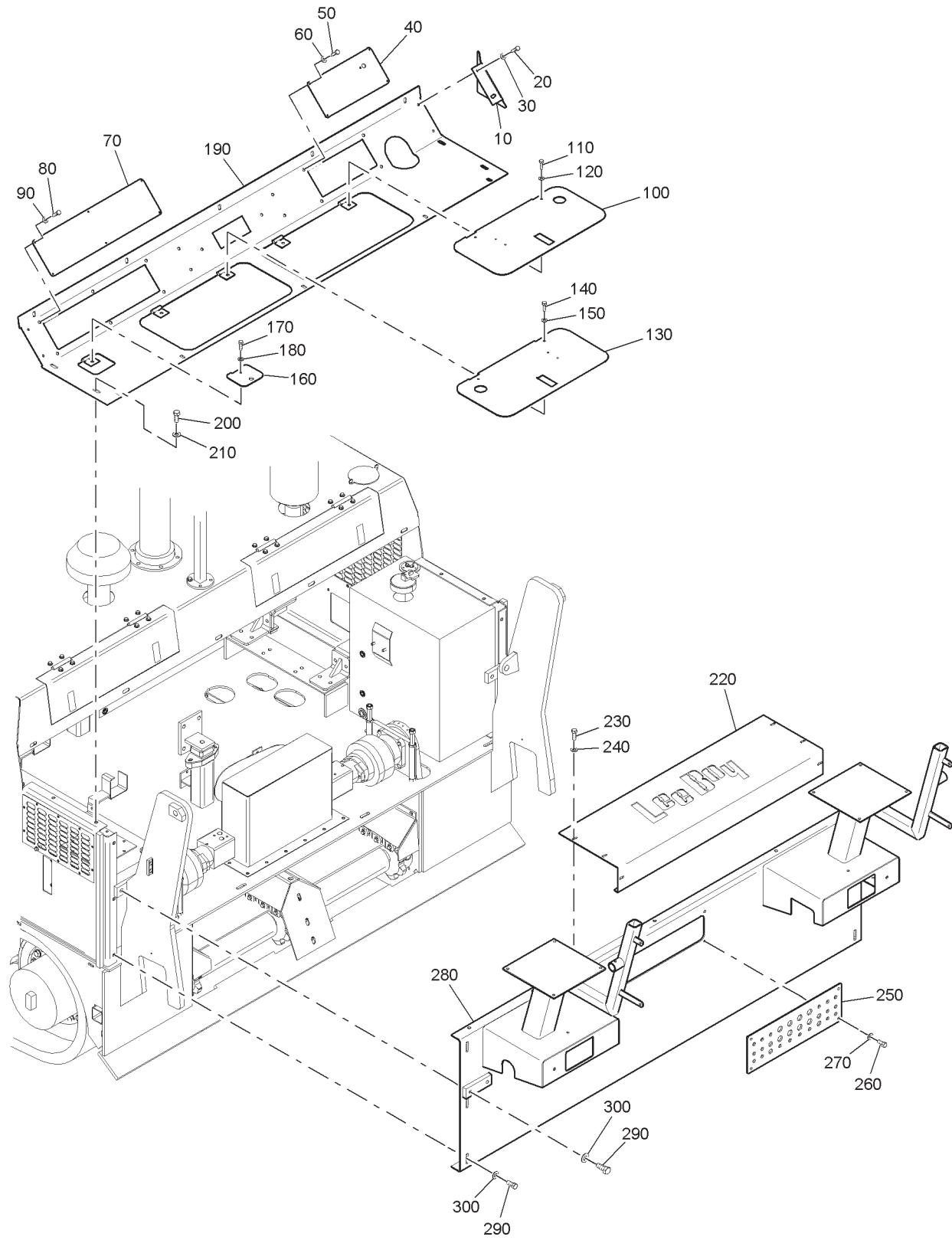

FIGURE 23. FLOOR BOARD ASSEMBLY

FIGURE 23. FLOOR BOARD ASSEMBLY

FIG ITEM	PART NUMBER	NOMENCLATURE							UNITS PER ASSY
		1	2	3	4	5	6	7	
23									
-1	TBD	FLOOR BOARD ASSEMBLY							REF
10	980953R	• ANGLE PLATE. RH							1
-11	980953L	• ANGLE PLATE. LH							1
		ATTACHING PARTS							
20	102-206-1A	• SCREW, 3/8" - 16 X 1.25 HEX CAP							2
30	119-3	• WASHER, 3/8" FLAT							2
		-----*-----							
40	980294	• WIREWAY COVER							1
		ATTACHING PARTS							
50	102-105-1A	• SCREW, 5/16" - 16 X 1.0 HEX CAP							4
60	119-2	• WASHER, 5/16" FLAT							4
		-----*-----							
70	980291	• WIREWAY COVER							1
		ATTACHING PARTS							
80	102-105-1A	• SCREW, 5/16" - 18 X 1.0 HEX CAP							6
90	119-2	• WASHER, 5/16" FLAT							6
		-----*-----							
100	980288R	• PLATE, FLOORBOARD, RH							1
		ATTACHING PARTS							
110	102-105-1A	• SCREW, 5/16" - 18 X 1.0 HEX CAP							6
120	119-2	• WASHER, 5/16" FLAT							6
		-----*-----							

NP = NOT PROCURABLE
 - ITEM NOT ILLUSTRATED

ILLUSTRATED PARTS LIST



FIGURE 23. FLOOR BOARD ASSEMBLY (CONTINUED)

FIG ITEM	PART NUMBER	NOMENCLATURE							UNITS PER ASSY
		1	2	3	4	5	6	7	
23									
130	980288L	• PLATE, FLOORBOARD, LH							1
		ATTACHING PARTS							
140	102-105-1A	• SCREW, 5/16" - 18 X 1.0 HEX CAP							6
150	119-2	• WASHER, 5/16" FLAT							6
		-----*							
160	980736	• PLATE, HYDRAULIC ACCESS							1
		ATTACHING PARTS							
170	102-105-1A	• SCREW, 5/16" - 18 X 1.0 HEX CAP							1
180	119-2	• WASHER, 5/16" FLAT							1
		-----*							
190	980292	• FLOORBOARD							1
		ATTACHING PARTS							
200	102-407-1A	• SCREW, 1/2" - 13 X 1.5 HEX CAP							13
210	119-5	• WASHER, 1/2" FLAT							13
		-----*							
220	980101	• PLATE, REAR COVER							1
		ATTACHING PARTS							
230	100-206-1A	• SCREW, 3/8" - 16 X 1.25 HEX CAP, FINE THREAD							6
240	119-3	• WASHER, 3/8" FLAT							6
		-----*							

NP = NOT PROCURABLE
 - ITEM NOT ILLUSTRATED

FIGURE 23. FLOOR BOARD ASSEMBLY (CONTINUED)

FIG ITEM	PART NUMBER	NOMENCLATURE							UNITS PER ASSY
		1	2	3	4	5	6	7	
23									
250	980286	• PLATE, HYDRAULIC OUTPUT							1
		ATTACHING PARTS							
260	100-206-1A	• SCREW, 3/8" - 16 X 1.25 HEX CAP, FINE THREAD							4
270	119-3	• WASHER, 3/8" FLAT							4
		-----*							
280	3NONUMBER280	• REAR PLATE, WELDMENT							1
		ATTACHING PARTS							
290	102-609-1A	• SCREW, 5/8" - 11 X 2.0 HEX CAP							10
300	119-7	• WASHER, 5/8" FLAT							10
		-----*							

NP = NOT PROCURABLE
 - ITEM NOT ILLUSTRATED

ILLUSTRATED PARTS LIST

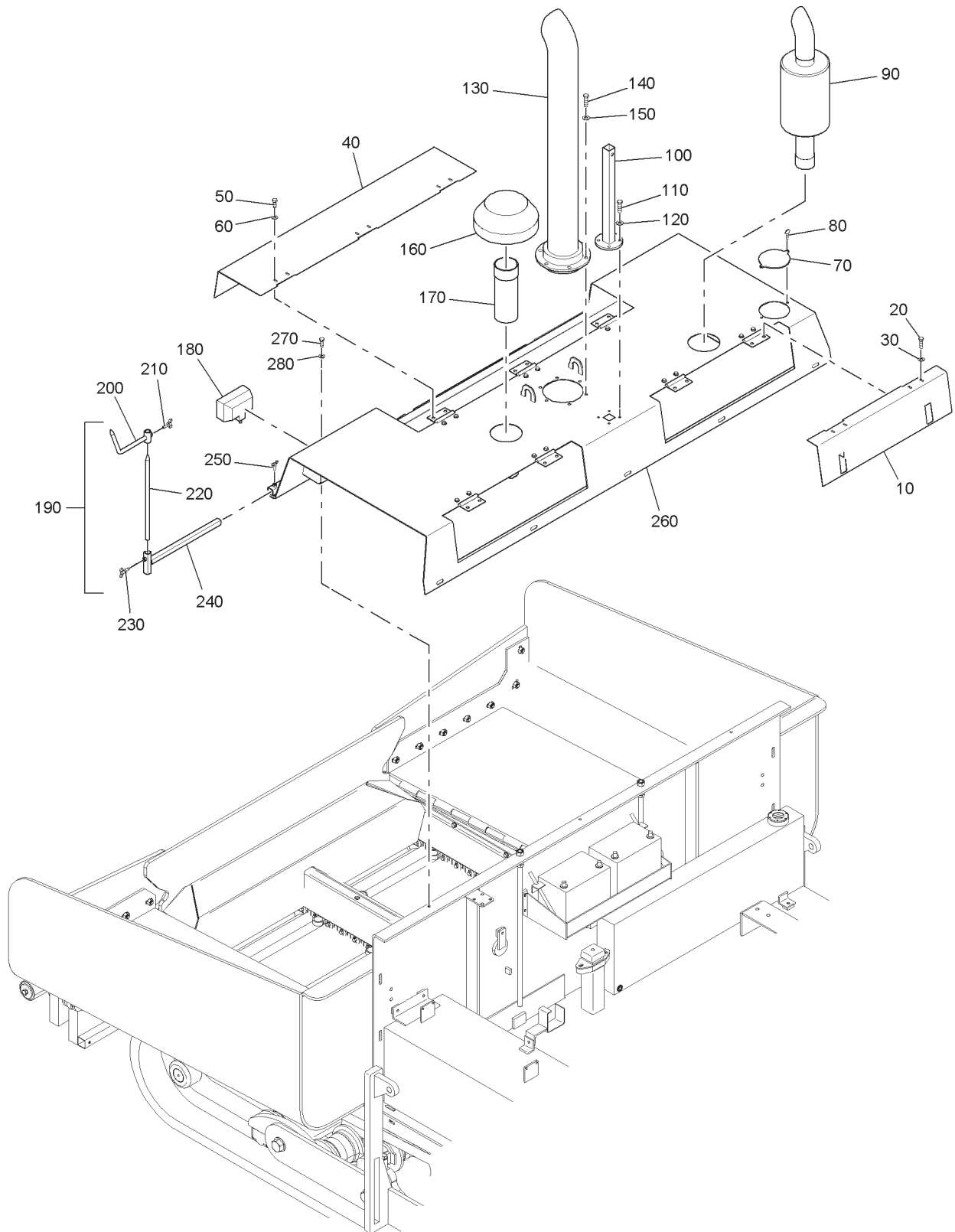

FIGURE 24. HOODS AND COVERS (Sheet 1 of 3)

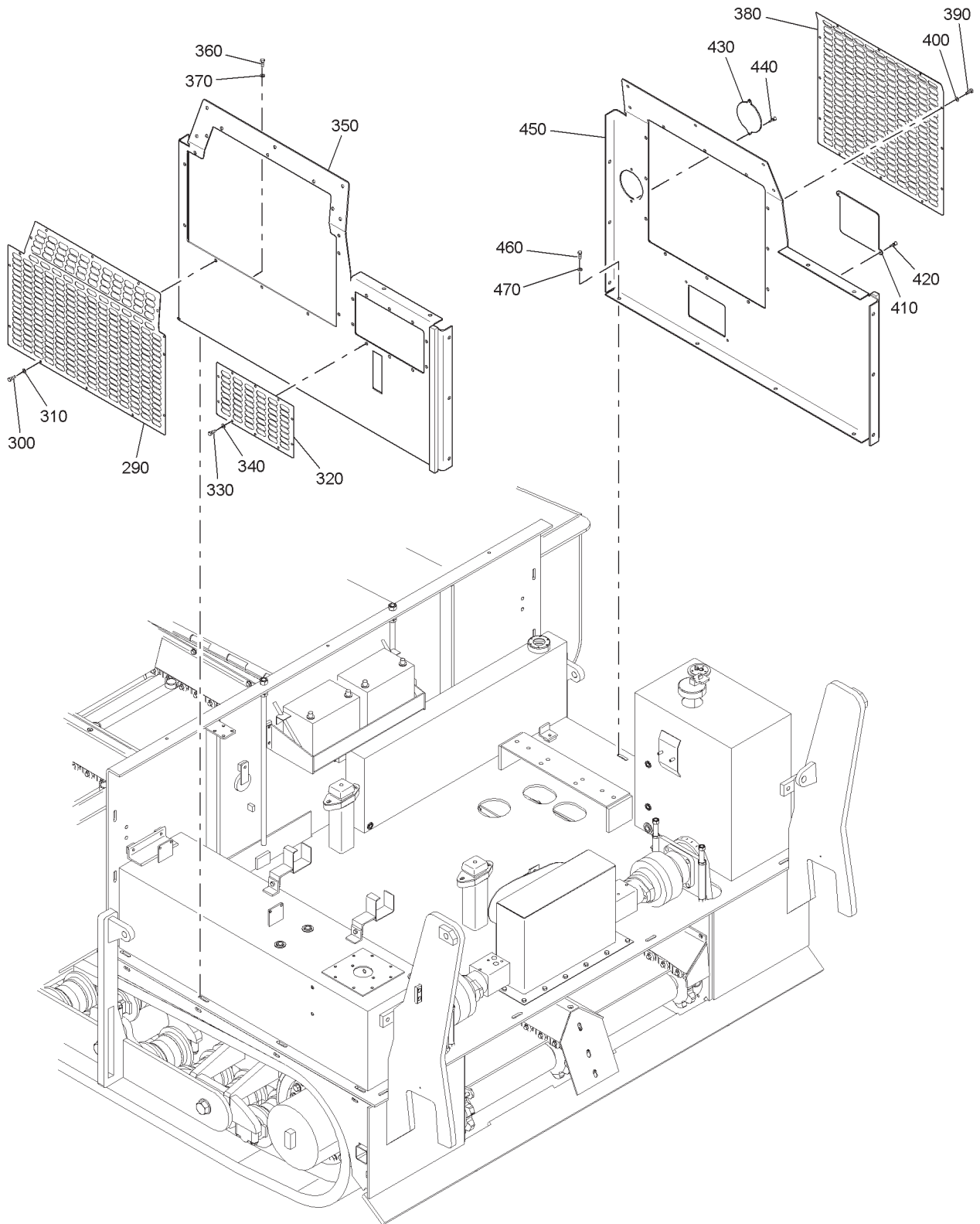
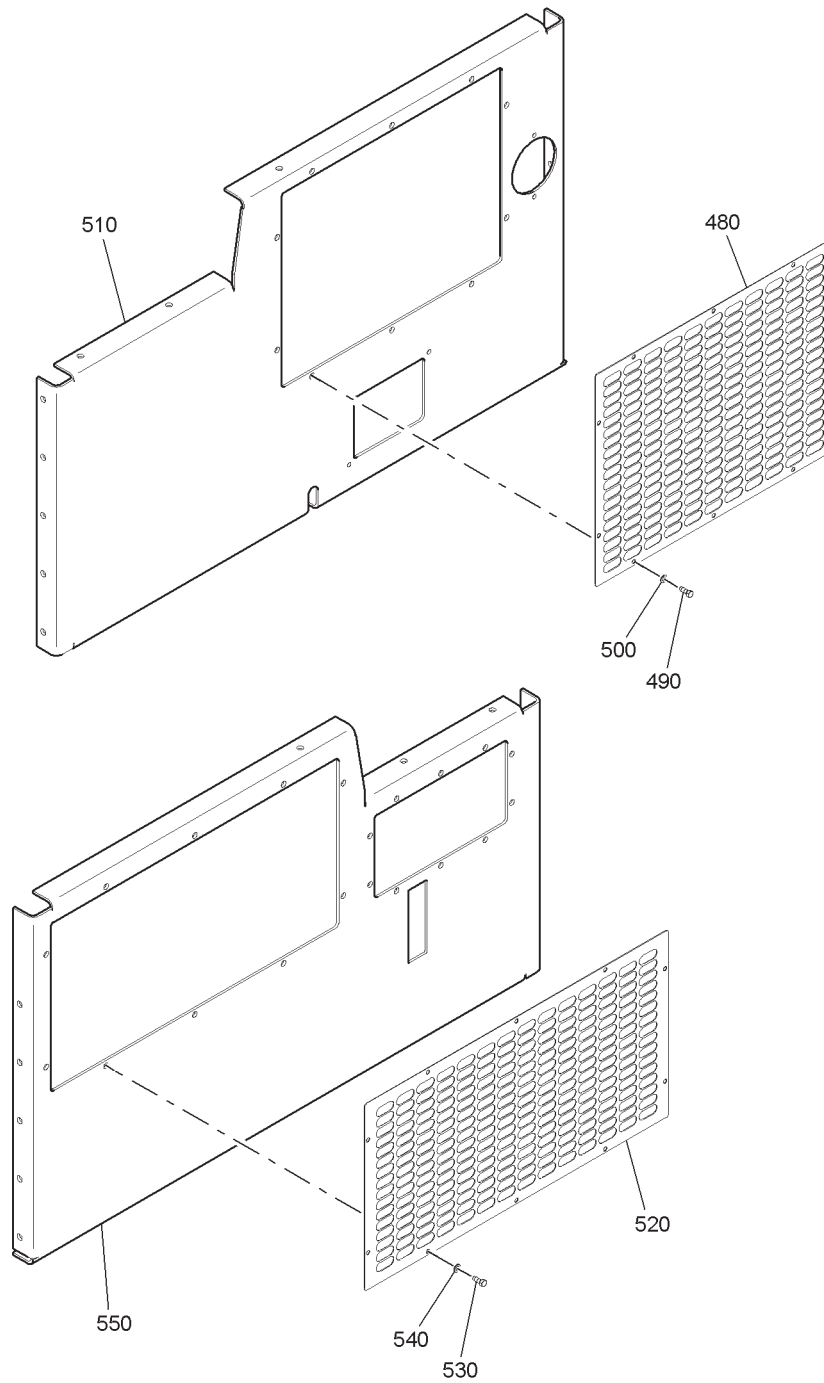

FIGURE 24. HOODS AND COVERS (Sheet 2 of 3)

ILLUSTRATED PARTS LIST



ALTERNATE CONFIGURATION

FIGURE 24. HOODS AND COVERS (Sheet 3 of 3)

FIGURE 24. HOODS AND COVERS

FIG ITEM	PART NUMBER	NOMENCLATURE							UNITS PER ASSY
		1	2	3	4	5	6	7	
24									
-1	TBD	HOODS AND COVERS							REF
10	980307	• ENGINE COVER, REAR ACCESS							2
		ATTACHING PARTS							
20	102-105-1A	• SCREW, 5/16" - 16 X 1.0 HEX CAP							4
30	119-2	• WASHER, 5/16" FLAT							4
		-----*							
40	980308	• ENGINE COVER, FRONT ACCESS							1
		ATTACHING PARTS							
50	102-105-1A	• SCREW, 5/16" - 16 X 1.0 HEX CAP							6
60	119-2	• WASHER, 5/16" FLAT							6
		-----*							
70	980285	• CITRUS COVER							1
		ATTACHING PARTS							
80	920070	• CAP SCREW, 7/16" - 14 X 1.25 HEX CAP, THUMB							2
		-----*							
90	984441	• MUFFLER							1
100	980376	• BEACON LIGHT MOUNT ASSEMBLY							1
-101	211748-02	• STROBE LIGHT, AMBER							1
		ATTACHING PARTS							
110	102-209-1A	• SCREW, 3/8" - 16 X 2.0 HEX CAP							4
120	119-3	• WASHER, 3/8" FLAT							4
		-----*							

NP = NOT PROCURABLE
 - ITEM NOT ILLUSTRATED

ILLUSTRATED PARTS LIST



FIGURE 24. HOODS AND COVERS (CONTINUED)

FIG ITEM	PART NUMBER	NOMENCLATURE							UNITS PER ASSY
		1	2	3	4	5	6	7	
24									
130	980860	• EXHAUST STACK							1
		ATTACHING PARTS							
140	102-409-1A	• SCREW, 1/2" - 13 X 2.0 HEX CAP							6
150	119-5	• WASHER, 1/2" FLAT							6
		-----*							
160	38467	• AIR BREATHER COVER							1
170	981523	• INTERMEDIATE PIPE, AIR BREATHER							1
180	160040A	• WORK LIGHT							2
190	980373	• SIGHT GAUGE ASSEMBLY							2
200	980365	•• BAR, ROUND BENT							1
210	920070	•• SCREW, 7/16" - 14 X 1.25 HEX CAP, WING							1
220	980366	•• BAR, ROUND							1
230	920070	•• SCREW, 7/16" - 14 X 1.25 HEX CAP, WING							1
240	980382	•• MOUNT, SIGHT GAUGE							1
250	920070	•• SCREW, 7/16" - 14 X 1.25 HEX CAP, WING							1
260	980313	• HOOD							1
		ATTACHING PARTS							
270	102-405-1A	• SCREW, 1/2" - 13 X 1.0 HEX CAP							3
280	119-5	• WASHER, 1/2" FLAT							3
		-----*							
290	980283	• VENT, SIDE COVER							1
		ATTACHING PARTS							
300	102-105-1A	• SCREW, 5/16" - 16 X 1.0 HEX CAP							14
310	119-2	• WASHER, 5/16" FLAT							14
		-----*							

NP = NOT PROCURABLE
 - ITEM NOT ILLUSTRATED

FIGURE 24. HOODS AND COVERS (CONTINUED)

FIG ITEM	PART NUMBER	NOMENCLATURE							UNITS PER ASSY
		1	2	3	4	5	6	7	
24									
320	982270	• VENT, HYDRAULIC, HIGH FLOW, SM							1
		ATTACHING PARTS							
330	102-105-1A	• SCREW, 5/16" - 16 X 1.0 HEX CAP							10
340	119-2	• WASHER, 5/16" FLAT							10
		-----*							
350	980281L	• PLATE, LH SIDE							1
		ATTACHING PARTS							
360	102-407-1A	• CAP SCREW, 1/2" - 13 X 1.5 HEX CAP							7
370	119-5	• WASHER, 1/2" FLAT							7
		-----*							
380	980282	• VENT, RADIATOR COVER							1
		ATTACHING PARTS							
390	102-105-1A	• SCREW, 5/16" - 16 X 1.0 HEX CAP							12
400	119-2	• WASHER, 5/16" FLAT							12
		-----*							
410	980284	• COVER, SIDE							1
		ATTACHING PARTS							
420	920070	• WING BOLT 3/8"							2
		-----*							
430	980285	• CITRUS COVER							1
		ATTACHING PARTS							
440	920070	• SCREW, 7/16" - 14 X 1.25 HEX CAP, THUMB							2
		-----*							

NP = NOT PROCURABLE
 - ITEM NOT ILLUSTRATED

**This Page
Intentionally
Left Blank**

FIGURE 24. HOODS AND COVERS (CONTINUED)

FIG ITEM	PART NUMBER	NOMENCLATURE							UNITS PER ASSY
		1	2	3	4	5	6	7	
24									
450	980281R	• PLATE, RH SIDE							1
		ATTACHING PARTS							
460	102-407-1A	• SCREW, 1/2" - 13 X 1.5 HEX CAP							7
470	119-5	• WASHER, 1/2" FLAT							7
		-----*							
		ALTERNATE CONFIGURATION							
480	982269R	• VENT, RADIATOR COVER							1
		ATTACHING PARTS							
490	102-205-1A	• SCREW, 3/8" - 16 X 1.0 HEX CAP							10
500	119-3	• WASHER, 3/8" FLAT							10
		-----*							
510	982268R	• PLATE, RH SIDE							1
520	982269L	• VENT, SIDE COVER							1
		ATTACHING PARTS							
530	102-205-1A	• SCREW, 3/8" - 16 X 1.0 HEX CAP							10
540	119-3	• WASHER, 3/8" FLAT							10
		-----*							
550	982268L	•• PLATE, LH SIDE							1

NP = NOT PROCURABLE
 - ITEM NOT ILLUSTRATED

ILLUSTRATED PARTS LIST

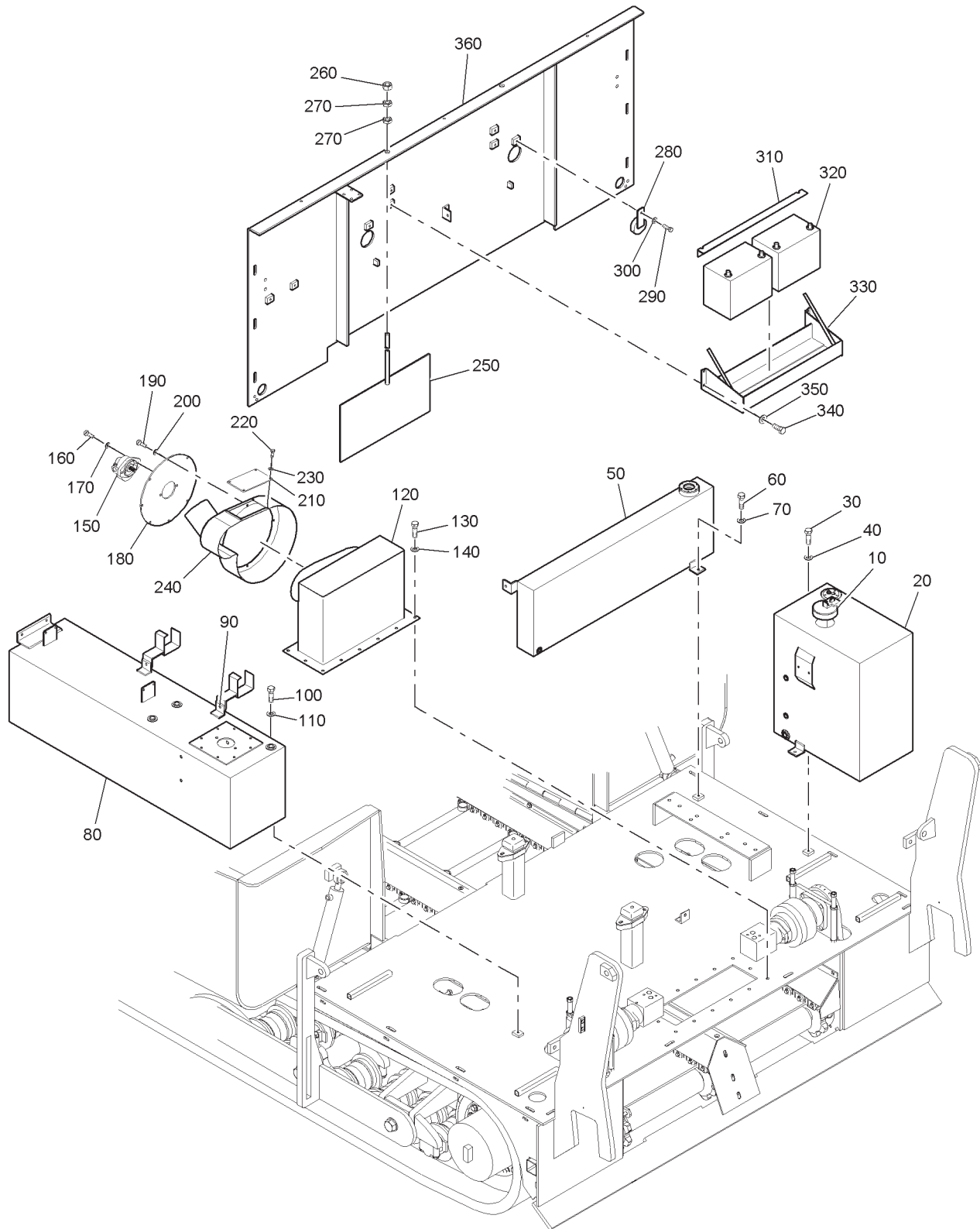

FIGURE 25. TANKS

FIGURE 25. TANKS

FIG ITEM	PART NUMBER	NOMENCLATURE							UNITS PER ASSY
		1	2	3	4	5	6	7	
25									
-1	TBD	TANKS							REF
10	982033	• CAP, FUEL, LOCKABLE							1
20	980176	• ASSY, FUEL TANK							1
-21	900010	SPRAYDOWN PUMP							1
		ATTACHING PARTS							
30	100-206-1A	• SCREW, 3/8"- 16 X 1.25 HEX CAP, FINE THREAD							2
40	119-3	• WASHER, 3/8" FLAT							2
		-----*-----							
50	980172	• ASSY, CITRUS TANK							1
		ATTACHING PARTS							
60	100-206-1A	• SCREW, 3/8"- 16 X 1.25 HEX CAP, FINE THREAD							2
70	119-3	• WASHER, 3/8" FLAT							2
		-----*-----							
80	980174	• ASSEMBLY, HYDRAULIC TANK							1
90	102-205-1A	• SCREW, 3/8" - 16 X 1.0 HEX CAP							2
		ATTACHING PARTS							
100	100-206-1A	• SCREW, 3/8"- 16 X 1.25 HEX CAP, FINE THREAD							4
110	119-3	• WASHER, 3/8" FLAT							4
		-----*-----							
120	980713	• EXHAUST FAN HOUSING ASSEMBLY							1

NP = NOT PROCURABLE
 - ITEM NOT ILLUSTRATED

ILLUSTRATED PARTS LIST



FIGURE 25. TANKS (CONTINUED)

FIG ITEM	PART NUMBER	NOMENCLATURE							UNITS PER ASSY
		1	2	3	4	5	6	7	
25									
		ATTACHING PARTS							
130	102-306-1A	• SCREW, 7/16" - 14 X 1.25 HEX CAP							14
140	119-4	• WASHER, 7/16" FLAT							14
		-----*							
150	980590	• MOTOR, HYDRAULIC							1
		ATTACHING PARTS							
160	102-207-1A	• SCREW, 3/8" - 16 X 1.5 HEX CAP							2
170	119-3	• WASHER, 3/8" FLAT							2
		-----*							
180	980705	• MOUNTING PLATE, HYDRAULIC MOTOR							1
		ATTACHING PARTS							
190	102-5-1A	• SCREW, 1/4" - 20 X 0.5 HEX CAP							8
200	119-1	• WASHER, 1/4" FLAT							8
		-----*							
210	981731	• COVER, HOOD EXHAUST MOTOR							1
		ATTACHING PARTS							
220	102-5-1A	• CAP SCREW, 1/4" - 20 X 1" HEX							4
230	119-1	• WASHER, 1/4" FLAT							4
		-----*							
240	980707	• HOOD, EXHAUST MOTOR							1
250	980169	• FLOWGATE							1

NP = NOT PROCURABLE
 - ITEM NOT ILLUSTRATED

FIGURE 25. TANKS (CONTINUED)

FIG ITEM	PART NUMBER	NOMENCLATURE							UNITS PER ASSY
		1	2	3	4	5	6	7	
25									
		ATTACHING PARTS							
260	117-8	• NUT, 3/4", HEX HEAVY							1
270	116-8-1	• NUT, 3/4", HEX, JAM							2
		-----*							
280	980388	• COVER, ACCESS							2
		ATTACHING PARTS							
290	100-206-1A	• SCREW, 3/8" - 16 X 1.25 HEX CAP, FINE THREAD							1
300	119-3	• WASHER, 3/8" FLAT							1
		-----*							
310	856985	• HOLDDOWN, BATTERY							1
320	920152	• BATTERY							2
330	980595	• BATTERY TRAY							1
		ATTACHING PARTS							
340	100-206-1A	• SCREW, 3/8" - 16 X 1.25 HEX CAP, FINE THREAD							4
350	119-3	• WASHER, 3/8" FLAT							4
		-----*							
360	980086	• PLATE, HOPPER BACK							1

NP = NOT PROCURABLE
 - ITEM NOT ILLUSTRATED

ILLUSTRATED PARTS LIST

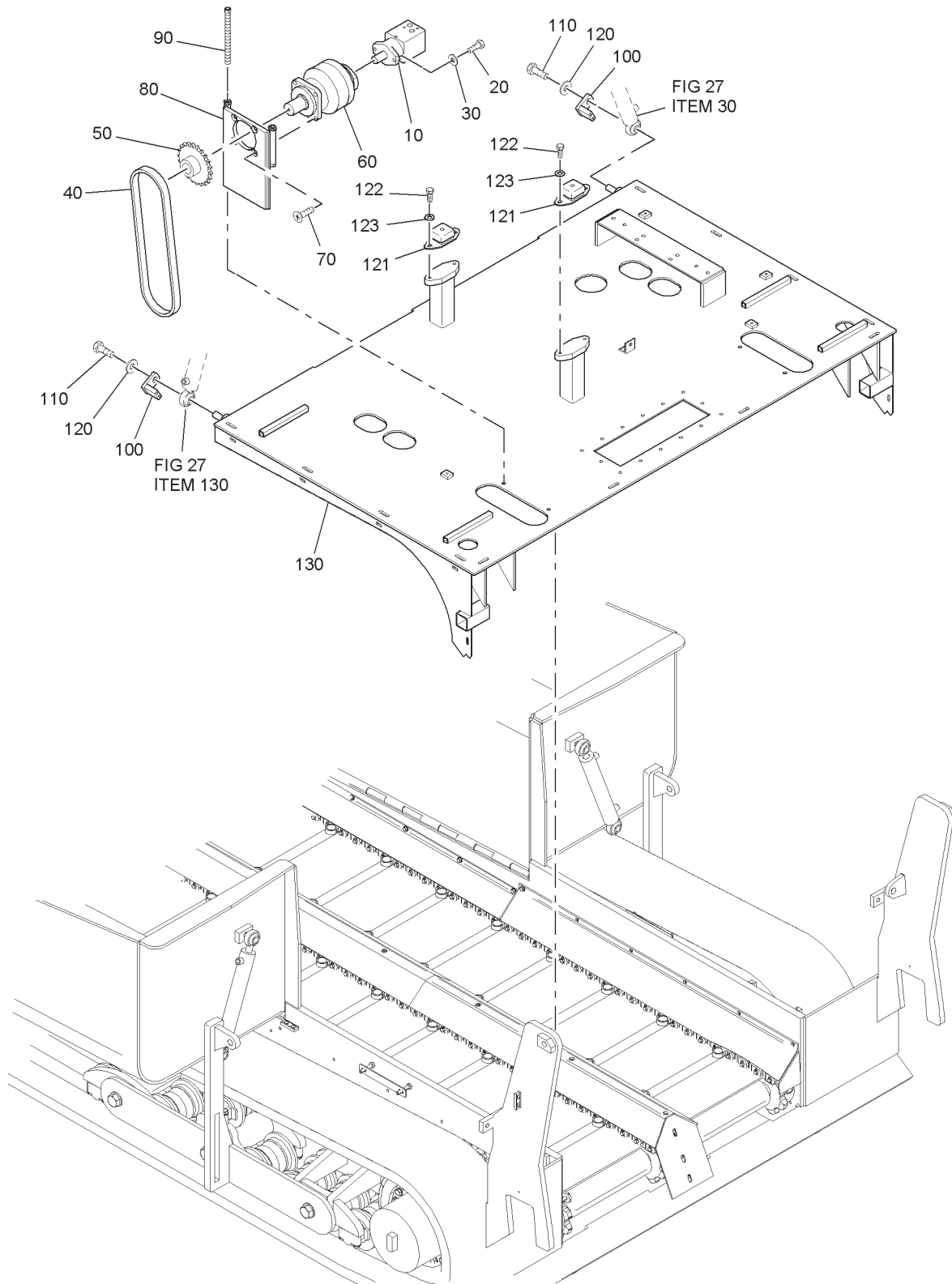

FIGURE 26. DRIVE CONVEYOR

FIGURE 26. DRIVE CONVEYOR

FIG ITEM	PART NUMBER	NOMENCLATURE							UNITS PER ASSY
		1	2	3	4	5	6	7	
26									
-1	TBD	DRIVE CONVEYOR							REF
10	980210	• HYDAULIC MOTOR, CONVEYOR DRIVE							2
		ATTACHING PARTS							
20	100-406-1A	• SCREW, 1/2"- 13 X 1.25 HEX CAP							2
30	119-5	• WASHER, 1/2" FLAT							2
		-----*							
40	980220	• CHAIN, CONVEYOR							2
50	980165	• SPROCKET, CONVEYOR DRIVE							2
60	980200	• TORQUE HUB, CONVEYOR DRIVE							2
		ATTACHING PARTS							
70	108-606-1A	• SCREW, 5/8" - 16 X 1.25 SET							2
		-----*							
80	980109	• SLIDE, CONVEYOR ADJUSMENT							2
90	980106	• ASSEMBLY, CONVEYOR DRIVE ADJUSMENT							4
100	980157	• RETAINER, HYDRAULIC CYLINDER							2
		ATTACHING PARTS							
110	102-908-1A	• SCREW, 1.0" - 8 X 1.75 HEX CAP							1
120	119-10	• WASHER, 1.0" FLAT							1
		-----*							
121	320140-1	• MOUNTING PAD							2
		ATTACHING HARDWARE							
122	100-406-1A	• CAP SCREW, 1/2" - 13 X 1.25							2
123	119-5	• WASHER, 1/2" FLAT							2
		-----*							
130	980085	• MOUNTING PLATE, WELDMENT							1

NP = NOT PROCURABLE
 - ITEM NOT ILLUSTRATED

ILLUSTRATED PARTS LIST

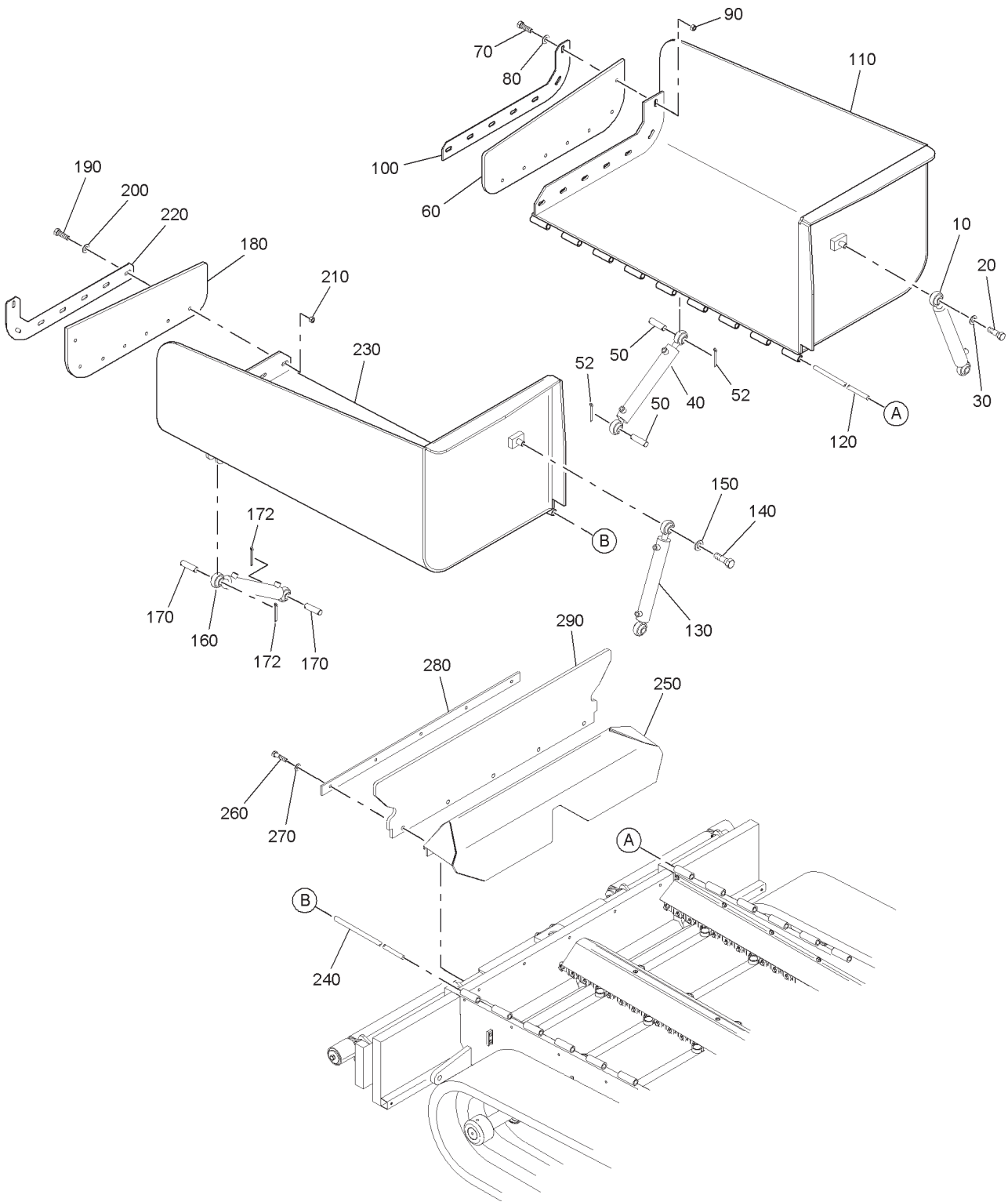

FIGURE 27. HOPPER WINGS

FIGURE 27. HOPPER WINGS

FIG ITEM	PART NUMBER	NOMENCLATURE							UNITS PER ASSY
		1	2	3	4	5	6	7	
27									
-1	TBD	HOPPER WINGS							REF
10	851436	• HYDAULIC CYLINDER							1
-11	851484	• SEAL KIT							1
		ATTACHING PARTS							
20	102-807-1A	• SCREW, 7/8" - 9 X 1.5 HEX CAP							1
30	119-9	• WASHER, 7/8" FLAT							1
		-----*							
40	851436	• HYDAULIC CYLINDER							1
-41	851484	• SEAL KIT							1
		ATTACHING PARTS							
50	980166	• PIN, CYLINDER							2
52	81019	• PIN, COTTER							2
		-----*							
60	980047	• FLASHING, HOPPER CORNER							1
		ATTACHING PARTS							
70	102-609-1A	• SCREW, 5/8"- 11 X 2.0 HEX CAP							7
80	119-7	• WASHER, 5/8" FLAT							7
90	116-7	• NUT, 5/8" HEX							7
		-----*							
100	980332	• PLATE, SIDEWING RUBBER SHEILD							1
110	980037R	• SIDEWING, HOPPER RH							1
		ATTACHING PARTS							
120	980042	• BAR, ROUND SIDEWING HINGE							1
		-----*							
130	851436	• HYDAULIC CYLINDER							1
-131	851484	• SEAL KIT							1

NP = NOT PROCURABLE
 - ITEM NOT ILLUSTRATED

ILLUSTRATED PARTS LIST



FIGURE 27. HOPPER WINGS CONTINUED)

FIG ITEM	PART NUMBER	NOMENCLATURE							UNITS PER ASSY
		1	2	3	4	5	6	7	
27									
		ATTACHING PARTS							
140	102-807-1A	• SCREW, 7/8" - 9 X 1.5 HEX CAP							1
150	119-9	• WASHER, 7/8" FLAT							1
		-----*							
160	851436	• HYDAULIC CYLINDER							1
-161	851484	• SEAL KIT							1
		ATTACHING PARTS							
170	980166	• PIN, CYLINDER							2
172	81019	• PIN, COTTER							2
		-----*							
180	980047	• FLASHING, HOPPER CORNER							1
		ATTACHING PARTS							
190	102-609-1A	• SCREW, 5/8" - 11 X 2.0 HEX CAP							7
200	116-7	• WASHER, 5/8" FLAT							7
210	119-7	• NUT, 5/8" HEX							7
		-----*							
220	980332	• PLATE, SIDEWING RUBBER SHEILD							1
230	980037L	• SIDEWING, HOPPER LH							1
		ATTACHING PARTS							
240	980042	• BAR, ROUND SIDEWING HINGE							1
		-----*							
250	981069	• CHAINGAURD, FRONT							1
		ATTACHING PARTS							
260	102-410-1A	• SCREW, 1/2" - 13 X 2.25 HEX CAP							5
270	116-5	• NUT, 1/2" HEX							5
		-----*							

NP = NOT PROCURABLE
 - ITEM NOT ILLUSTRATED

FIGURE 27. HOPPER WINGS (CONTINUED)

FIG ITEM	PART NUMBER	NOMENCLATURE							UNITS PER ASSY
		1	2	3	4	5	6	7	
27									
280	980278	• BAR, FRONT RUBBER MOUNT							1
290	980046	• FLASHING, HOPPER FRONT							1

NP = NOT PROCURABLE
 - ITEM NOT ILLUSTRATED

ILLUSTRATED PARTS LIST

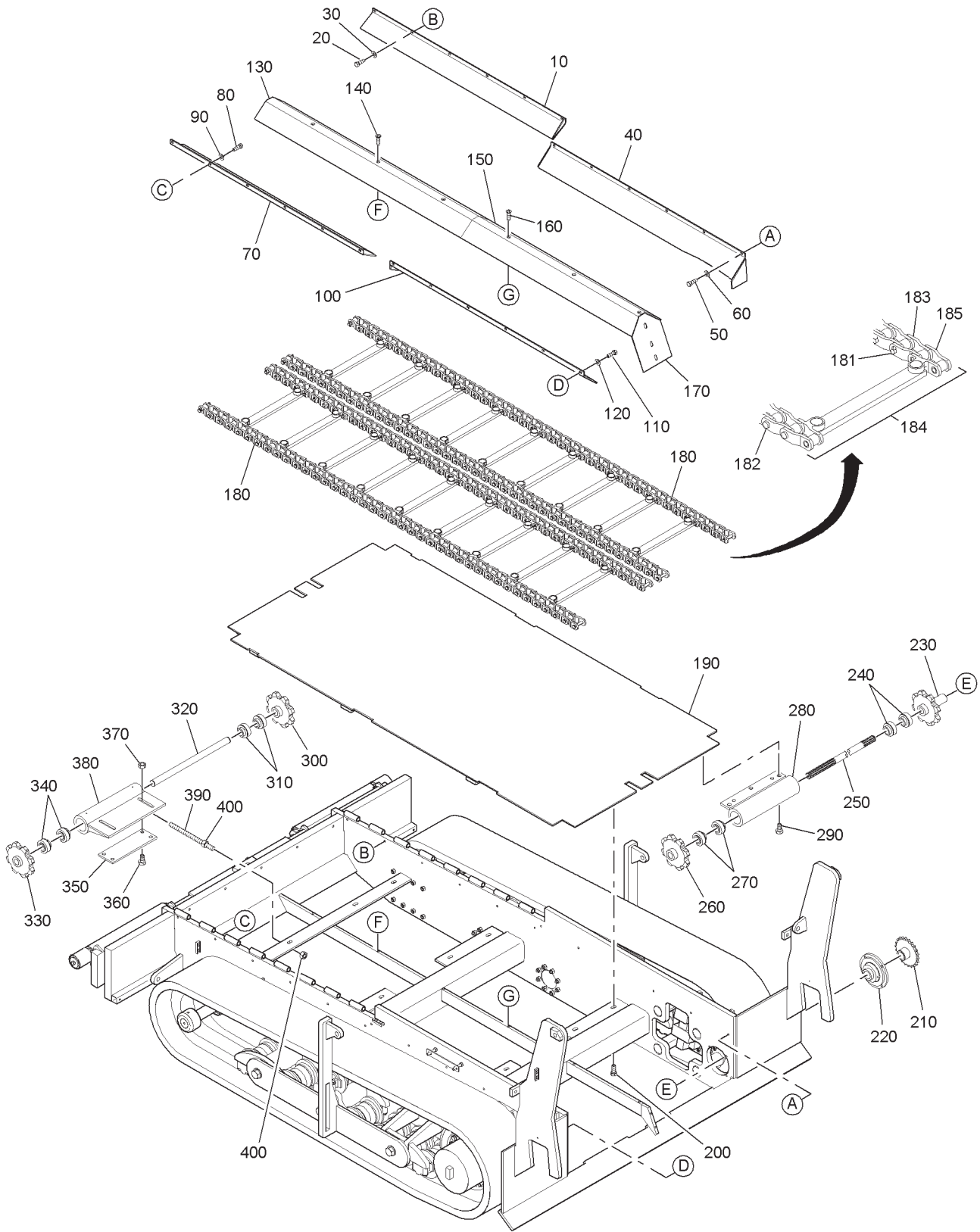

FIGURE 28. CONVEYOR ASSEMBLYS

FIGURE 28. CONVEYOR ASSEMBLY

FIG ITEM	PART NUMBER	NOMENCLATURE							UNITS PER ASSY
		1	2	3	4	5	6	7	
28									
-1	TBD	CONVEYOR ASSEMBLY							REF
10	980044R	• CHAIN GUARD, FRONT, RH							1
		ATTACHING PARTS							
20	102-410-1A	• SCREW, 1/2" - 13 X 2.25 HEX CAP							6
30	119-5	• WASHER, 1/2" FLAT							6
		-----*							
40	980098R	• CHAIN GUARD, REAR, RH							1
		ATTACHING PARTS							
50	102-410-1A	• SCREW, 1/2" - 13 X 2.25 HEX CAP							6
60	119-5	• WASHER, 1/2" FLAT							6
		-----*							
70	980044L	• CHAIN GUARD, FRONT, LH							1
		ATTACHING PARTS							
80	102-410-1A	• SCREW, 1/2" - 13 X 2.25 HEX CAP							6
90	119-5	• WASHER, 1/2" FLAT							6
		-----*							
100	980098L	• CHAIN GUARD, REAR, LH							1
		ATTACHING PARTS							
110	102-410-1A	• SCREW, 1/2" - 13 X 2.25 HEX CAP							6
120	119-5	• WASHER, 1/2" FLAT							6
		-----*							
130	980079	• CHAIN GUARD, FRONT, CENTER							1

NP = NOT PROCURABLE
 - ITEM NOT ILLUSTRATED

ILLUSTRATED PARTS LIST



FIGURE 28. CONVEYOR ASSEMBLY (CONTINUED)

FIG ITEM	PART NUMBER	NOMENCLATURE							UNITS PER ASSY
		1	2	3	4	5	6	7	
28									
		ATTACHING PARTS							
140	102-408-1A	• SCREW, 1/2" - 13 X 1.75 HEX CAP							4
		-----*							
150	980099	• CHAIN GUARD, REAR, CENTER							1
		ATTACHING PARTS							
160	102-408-1A	• SCREW, 1/2" - 13 X 1.75 HEX CAP							3
		-----*							
170	980087	• CHAIN GUARD, REAR							1
180	980680	• CHAIN ASSEMBLY, CONVEYOR							2
181	980730	• PIN, COTTER							A/R
182	980720	• PIN, LINK							A/R
183	980700	• LINK, CHAIN							A/R
184	980690	• DRAG BAR ASSY, COMPLETE							A/R
185	980690-01	• LINK, DRAG BAR							A/R
190	984979	• CONVEYOR FLOOR							1
		ATTACHING PARTS							
200	102-408-1A	• SCREW, 1/2" - 13 X 1.75 HEX CAP							12
		-----*							
210	980062	• SPROCKET, CONVEYOR, REAR							2
220	851483	• MOUNTING PLATE, CONVEYOR							2
230	980153	• SPROCKET, REAR AXLE HOUSING							2
240	850130	• BEARING, REAR AXLE HOUSING							4
250	980151	• DRIVE SHAFT, REAR AXLE HOUSING							2
260	980295	• SPROCKET, REAR AXLE HOUSING							2
270	850130	• BEARING, REAR AXLE HOUSING							4
280	980066	• REAR AXLE HOUSING							2
		ATTACHING PARTS							
290	102-608-1A	• SCREW, 5/8"- 13 X 1.75 HEX CAP							4
		-----*							

NP = NOT PROCURABLE
 - ITEM NOT ILLUSTRATED

FIGURE 28. CONVEYOR ASSEMBLY (CONTINUED)

FIG ITEM	PART NUMBER	NOMENCLATURE	UNITS PER ASSY
28			
300	980298	• SPROCKET, FRONT AXLE HOUSING	2
310	850130	• BEARING, FRONT AXLE HOUSING	4
320	854618	• DRIVE SHAFT, FRONT AXLE HOUSING	2
330	980298	• SPROCKET, FRONT AXLE HOUSING	2
340	850130	• BEARING, FRONT AXLE HOUSING	4
350	982183	• PLATE, FRONT AXLE HOUSING	2
		ATTACHING PARTS	
360	102-608-1A	• SCREW, 5/8" - 11 X 1.75 HEX CAP	2
370	116-7	• NUT, 5/8" HEX	2
		-----*	
380	980069	• FRONT AXLE HOUSING	
		ATTACHING PARTS	
390	983592	• SCREW, 5/8" - 11 X THREADED ROD	2
400	116-7	• NUT, 5/8" HEX	4

NP = NOT PROCURABLE
 - ITEM NOT ILLUSTRATED

ILLUSTRATED PARTS LIST

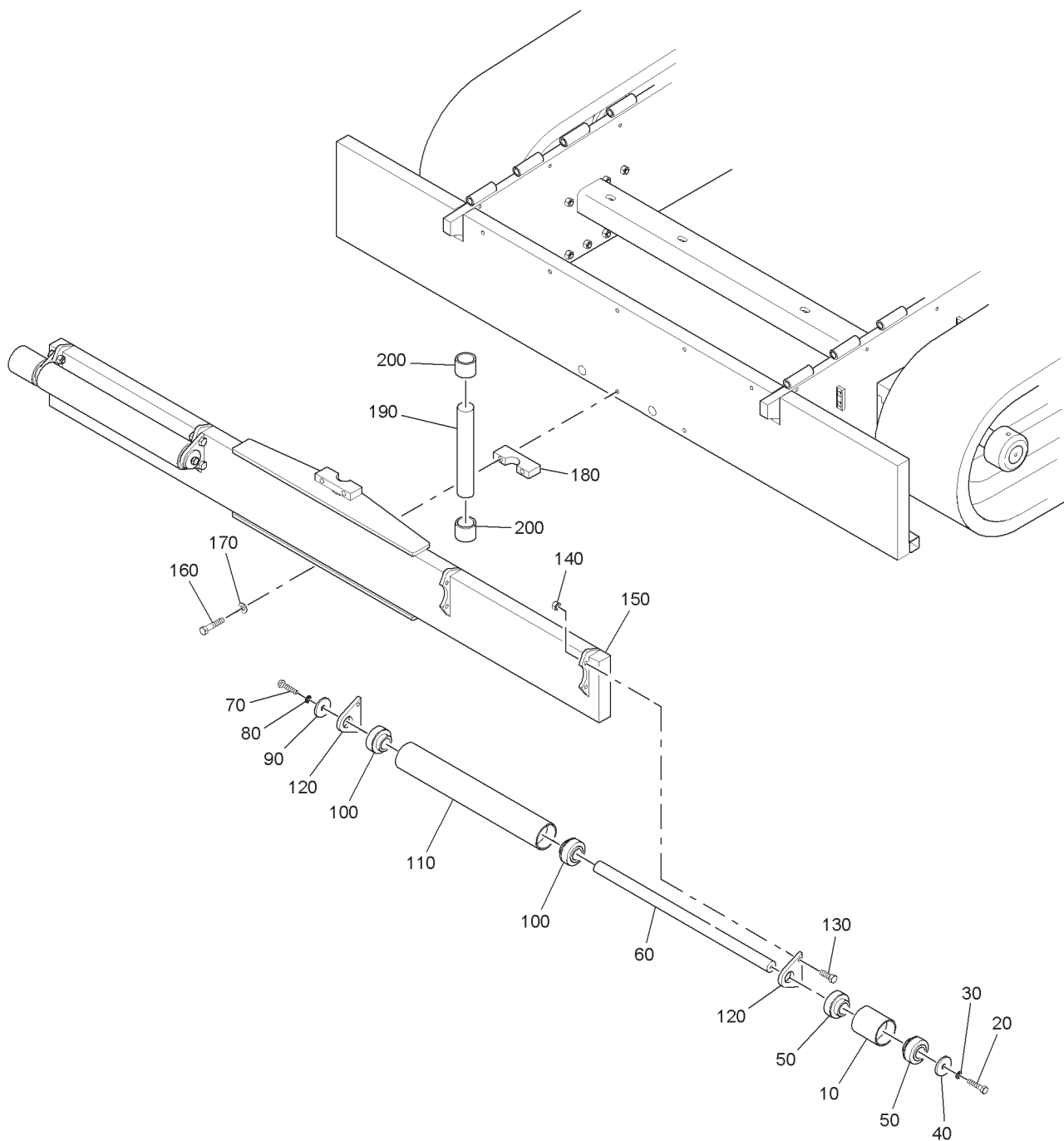

FIGURE 29. PUSHBAR

FIGURE 29. PUSHBAR

FIG ITEM	PART NUMBER	NOMENCLATURE							UNITS PER ASSY
		1	2	3	4	5	6	7	
29									
-1	TBD	PUSHBAR							REF
10	980036	• PIPE, PUSHBAR ROLLER							1
		ATTACHING PARTS							
20	102-410-1A	• SCREW, 1/2" - 13 X 2.25 HEX CAP							1
30	118-5	• WASHER, 1/2" FLAT, LOCK							1
40	240391	• WASHER, SCREED SWIVEL MOUNT							1
		-----*							
50	850130	• BEARING							2
60	980034	• SHAFT, PUSHBAR ROLLER							1
		ATTACHING PARTS							
70	102-410-1A	• SCREW, 1/2" - 13 X 2.25 HEX CAP							1
80	118-5	• WASHER, 1/2" FLAT, LOCK							1
90	240391	• WASHER, SCREED SWIVEL MOUNT							1
		-----*							
100	850130	• BEARING							2
110	980033	• PIPE, PUSHBAR ROLLER							1
120	980787	• ARM, PUSH BLOCK							2
		ATTACHING PARTS							
130	102-608-1A	• SCREW, 5/8" - 13 X 1.75 HEX CAP							2
140	116-7	• NUT, 5/8" HEX							2
		-----*							
150	980027	• ASSEMBLY, PUSH BAR MOUNT							1

NP = NOT PROCURABLE
 - ITEM NOT ILLUSTRATED

**This Page
Intentionally
Left Blank**

FIGURE 29. PUSHBAR (CONTINUED)

FIG ITEM	PART NUMBER	NOMENCLATURE							UNITS PER ASSY
		1	2	3	4	5	6	7	
29									
		ATTACHING PARTS							
160	102-613-1A	• SCREW, 5/8" - 13 X 3.0 HEX CAP							4
170	119-7	• WASHER, 5/8" FLAT							4
		-----*							
180	853345	• MOUNTING BLOCK							2
190	856954	• BAR, PUSH BAR PIN							1
200	810070	• BEARING, PUSH BAR PIN							2

NP = NOT PROCURABLE
 - ITEM NOT ILLUSTRATED

ILLUSTRATED PARTS LIST

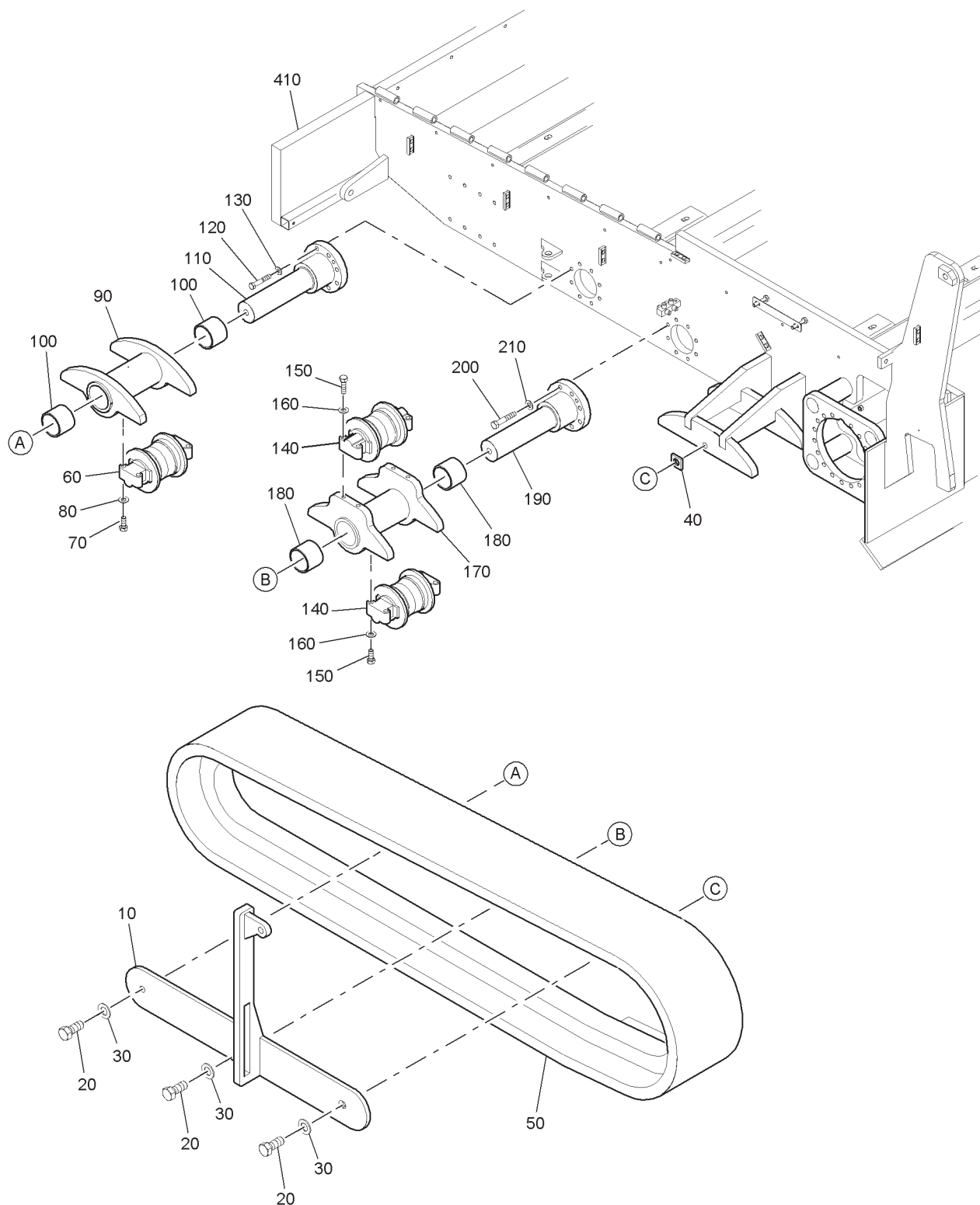

FIGURE 30. TRACK ASSEMBLY LH (Sheet 1 of 2)

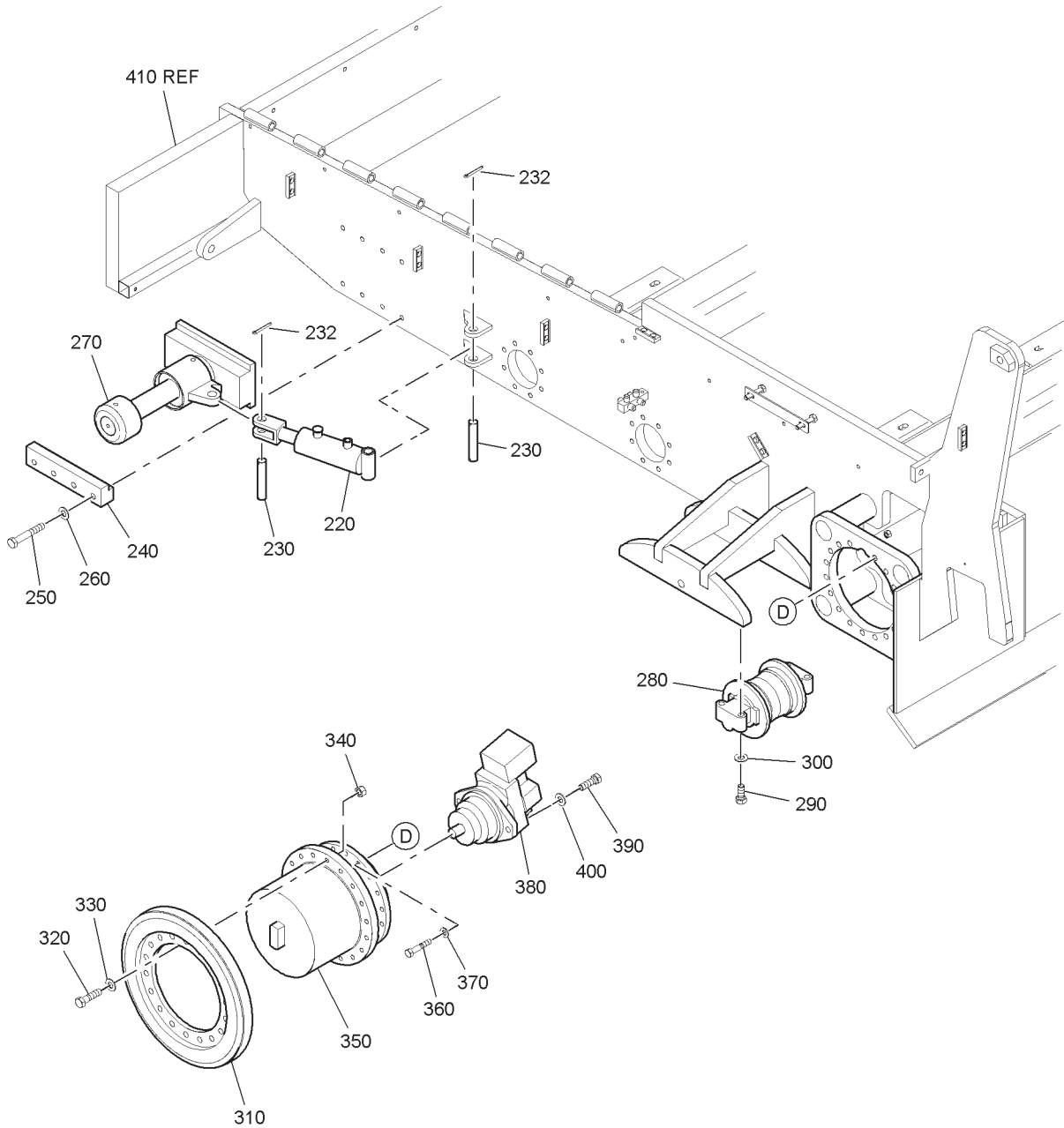

FIGURE 30. TRACK ASSEMBLY LH (Sheet 2 of 2)

**This Page
Intentionally
Left Blank**

FIGURE 29. TRACK ASSEMBLY

FIG ITEM	PART NUMBER	NOMENCLATURE							UNITS PER ASSY
		1	2	3	4	5	6	7	
30									
-1	1NONUMBER1	TRACK ASSEMBLY, LH							REF
-2	2NONUMBER2	TRACK ASSEMBLY, RH							REF
10	981420L	• PULL ARM, LH							1
11	981420R	• PULL ARM, RH							1
		ATTACHING PARTS							
20	100-909-1A	• SCREW, 1.0" - 8 X 2.0 HEX CAP, FINE THREAD							3
30	119-10	• WASHER, 1.0" FLAT							3
40	982125	• SHIM							1
		-----*-----							
50	980160	• TRACK							1
60	980100	• ASSEMBLY, BOGIE WHEEL							2
		ATTACHING PARTS							
70	100-613-1A	• SCREW, 5/8" - 13 X 3.0 HEX CAP							4
80	119-7	• WASHER, 5/8" FLAT							4
		-----*-----							
90	980076`	• ASSEMBLY, BOGIE ROLLER							1
100	980170	• BUSHING, BOGIE ROLLER							2
110	980019	• ASSEMBLY, BOGIE SHAFT							1
		ATTACHING PARTS							
120	100-611-1A	• SCREW, 5/8" - 11 X 2.5 HEX CAP, FINE THREAD							10
130	119-7	• WASHER, 5/8" FLAT							10
		-----*-----							

NP = NOT PROCURABLE
 - ITEM NOT ILLUSTRATED

ILLUSTRATED PARTS LIST



FIGURE 29. TRACK ASSEMBLY (CONTINUED)

FIG ITEM	PART NUMBER	NOMENCLATURE							UNITS PER ASSY
		1	2	3	4	5	6	7	
30									
140	980100	• ASSEMBLY, BOGIE WHEEL							3
		ATTACHING PARTS							
150	100-613-1A	• SCREW, 5/8" - 13 X 3.0 HEX CAP							4
160	119-7	• WASHER, 5/8" FLAT							4
		-----*							
170	980075	• ASSEMBLY, IDLER BOGIE ROLLER							1
180	980170	• BUSHING, BOGIE ROLLER							2
190	980019	• ASSEMBLY, BOGIE SHAFT							1
		ATTACHING PARTS							
200	100-611-1A	• SCREW, 5/8" - 11 X 2.5 HEX CAP, FINE THREAD							10
210	119-7	• WASHER. 5/8" FLAT							10
		-----*							
220	980150	• HYDRAULIC CYLINDER, TRACK TENSION							1
-222	980150-01	• SEAL KIT							1
		ATTACHING PARTS							
230	240030	• PIN, CLEVIS							2
232	81019	• PIN, COTTER							4
		-----*							
240	980056	• BAR, IDLER SIDE TAPPED							2
		ATTACHING PARTS							
250	100-614-1A	• SCREW, 5/8" - 11 X 3.25 HEX CAP, FINE THREAD							4
260	119-7	• WASHER, 5/8" FLAT							4
		-----*							
270	984346	• ASSEMBLY, FRONT IDLER W/ BLOCK							1

NP = NOT PROCURABLE
 - ITEM NOT ILLUSTRATED

FIGURE 29. TRACK ASSEMBLY (CONTINUED)

FIG ITEM	PART NUMBER	NOMENCLATURE							UNITS PER ASSY
		1	2	3	4	5	6	7	
30									
280	980100	• ASSEMBLY, BOGIE WHEEL							3
		ATTACHING PARTS							
290	100-613-1A	• SCREW, 5/8" - 13 X 3.0 HEX CAP							4
300	119-7	• WASHER, 5/8" FLAT							4
		-----*							
310	980140	• SPROCKET, TRACK							1
		ATTACHING PARTS							
320	100-613-1A	• SCREW, 5/8" - 13 X 3.0 HEX CAP							18
330	119-7	• WASHER, 5/8" FLAT							18
340	116-7	• NUT, 5/8" HEX							18
		-----*							
350	980110	• TORQUE HUB, TRACK DRIVE							1
		ATTACHING PARTS							
360	100-M16 X 55-1A	• SCREW, M16 X 55 HEX CAP							18
370	119-5	• WASHER, 1/2" FLAT							18
		-----*							
380	980120	• HYDRAULIC MOTOR, PROPULSION							1
		ATTACHING PARTS							
390	100-M16 X 55-1A	• SCREW, M16 X 55 HEX CAP							18
400	119-5	• WASHER, 1/2" FLAT							18
		-----*							
410	983629	• ASSEMBLY, FRAME							1

NP = NOT PROCURABLE
 - ITEM NOT ILLUSTRATED

ILLUSTRATED PARTS LIST

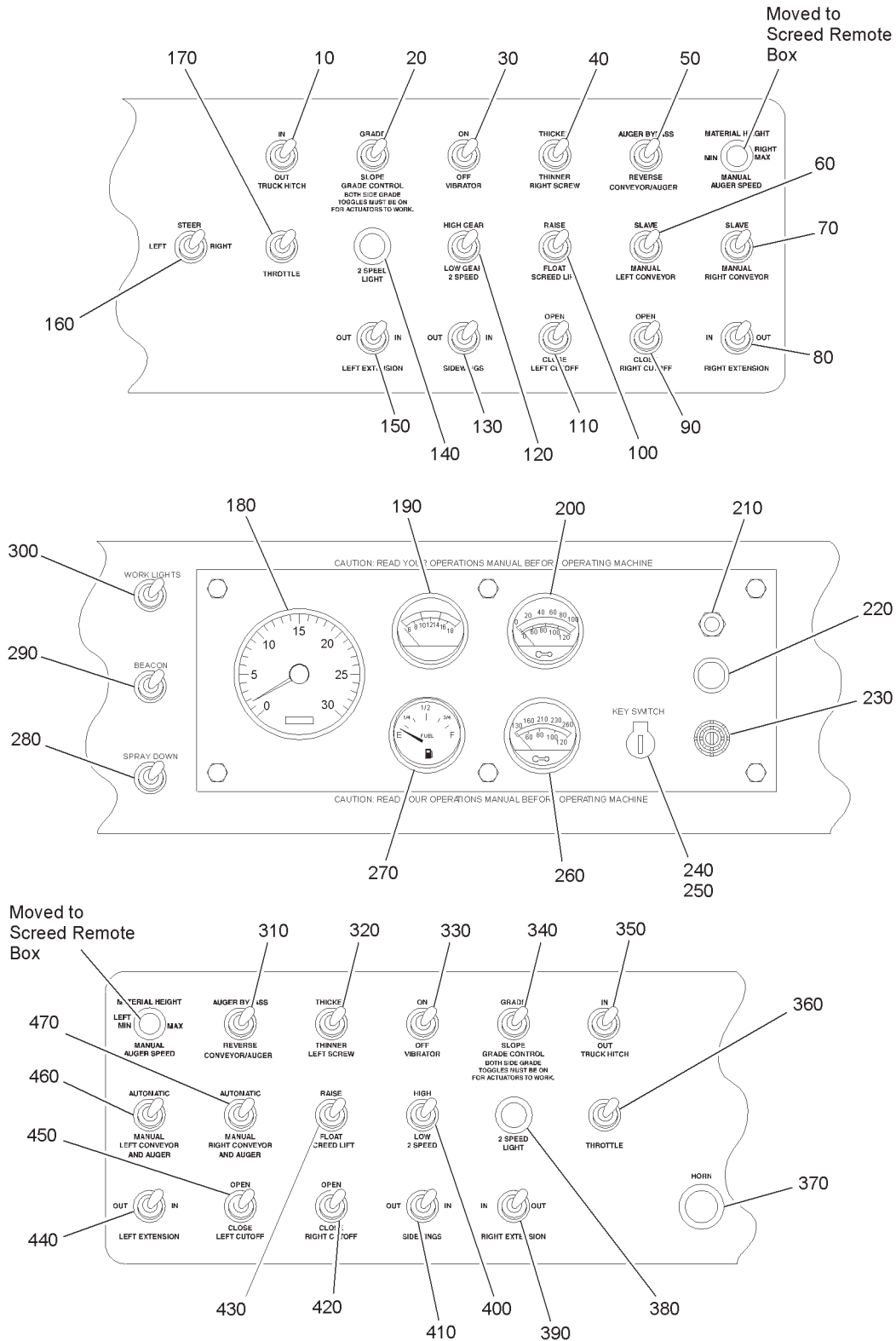

FIGURE 31. DASHBOARD COMPONENTS

FIGURE 31. DASHBOARD COMPONENTS

FIG ITEM	PART NUMBER	NOMENCLATURE							UNITS PER ASSY
		1	2	3	4	5	6	7	
31									
-1	TBD	DASHBOARD COMPONENTS							REF
10	851392	• SWITCH, TOGGLE - TRUCK HITCH							1
20	851391	• SWITCH, TOGGLE, SPST. 2 POS - GRADE CONTROL							1
30	851391	• SWITCH, TOGGLE, SPST. 2 POS - VIBRATOR							1
40	900080	• SWITCH, TOGGLE - RIGHT SCREW							1
50	900030	• SWITCH, TOGGLE - AUTO CONVEYOR							1
60	900030	• SWITCH, TOGGLE - MANUAL LEFT CONVEYOR							1
70	900030	• SWITCH, TOGGLE - MANUAL RIGHT CONVEYOR							1
80	851392	• SWITCH, TOGGLE - RIGHT EXTENSION							1
90	851392	• SWITCH, TOGGLE - RIGHT CUTOFF							1
100	900030	• SWITCH, TOGGLE -SCREED LIFT							1
110	851392	• SWITCH, TOGGLE - LEFT CUTOFF							1
120	851391	• SWITCH, TOGGLE, SPST. 2 POS - 2 SPEED							1
130	851392	• SWITCH, TOGGLE - SIDEWINGS							1
140	900120	• INDICATOR LIGHT (RED), HIGH							1
150	851392	• SWITCH, TOGGLE - LEFT EXTENSION							1
160	851394	• SWITCH, TOGGLE, 8500 ELITE III							1
170	900080	• SWITCH, TOGGLE - THROTTLE							1
180	140370	• GAUGE, TACHOMETER/HOURMETER							1
190	140390	• GAUGE, VOLTMETER							1
200	140410	• GAUGE, ENGINE OIL PRESSURE							1
210	140430	• CIRCUIT BREAKER, INSTRUMENT							1
220	140440	• WARNING LIGHT							1
230	140450	• WARNING BUZZER							1
240	36145	• SWITCH, IGNITION, 3 POS, 10 AMP							1
250	36145-01	• KEY, IGNITION (FOR SWITCH 36145 ONLY)							1
260	140400	• GAUGE, WATER TEMPERATURE							1
270	140380	• GAUGE, FUEL LEVEL							1
280	851391	• SWITCH, TOGGLE, SPST. 2 POS - SPRAYDOWN							1
-281	140470	RELAY, ENGINE SHUTDOWN							1
-282	859791	DECAL KIT, 8816							1

NP = NOT PROCURABLE

- ITEM NOT ILLUSTRATED

**This Page
Intentionally
Left Blank**

FIGURE 31. DASHBOARD COMPONENTS (CONTINUED)

FIG ITEM	PART NUMBER	NOMENCLATURE	UNITS PER ASSY
31			
290	851391	• SWITCH, TOGGLE, SPST. 2 POS - BEACON	1
300	851391	• SWITCH, TOGGLE, SPST. 2 POS - WORKLIGHTS	1
310	851390	• SWITCH, TOGGLE, AUTO CONVEYOR	1
320	900080	• SWITCH, TOGGLE, LEFT SCREW	1
330	851391	• SWITCH, TOGGLE, SPST. 2 POS - VIBRATOR	1
340	851391	• SWITCH, TOGGLE, SPST. 2 POS - GRADE CONTROL	1
350	851392	• SWITCH, TOGGLE - TRUCK HITCH	1
360	900080	• SWITCH, TOGGLE, - THROTTLE	1
370	900122	• SWITCH, PUSH BUTTON - HORN	1
380	900120	• INDICATOR LIGHT (RED), HIGH	1
390	851392	• SWITCH, TOGGLE, RIGHT EXTENSION	1
400	851391	• SWITCH, TOGGLE, SPST. 2 POS - 2 SPEED	1
410	851392	• SWITCH, TOGGLE - SIDEWINGS	1
420	851392	• SWITCH, TOGGLE - RIGHT CUTOFF	1
430	900030	• SWITCH, TOGGLE - SCREED LIFT	1
440	851392	• SWITCH, TOGGLE - LEFT EXTENSION	1
450	851392	• SWITCH, TOGGLE - LEFT CUTOFF	1
460	900030	• SWITCH, TOGGLE - LEFT CONVEYOR AND AUGER	1
470	900030	• SWITCH, TOGGLE - RIGHT CONVEYOR AND AUGER	1

NP = NOT PROCURABLE
 - ITEM NOT ILLUSTRATED

ILLUSTRATED PARTS LIST

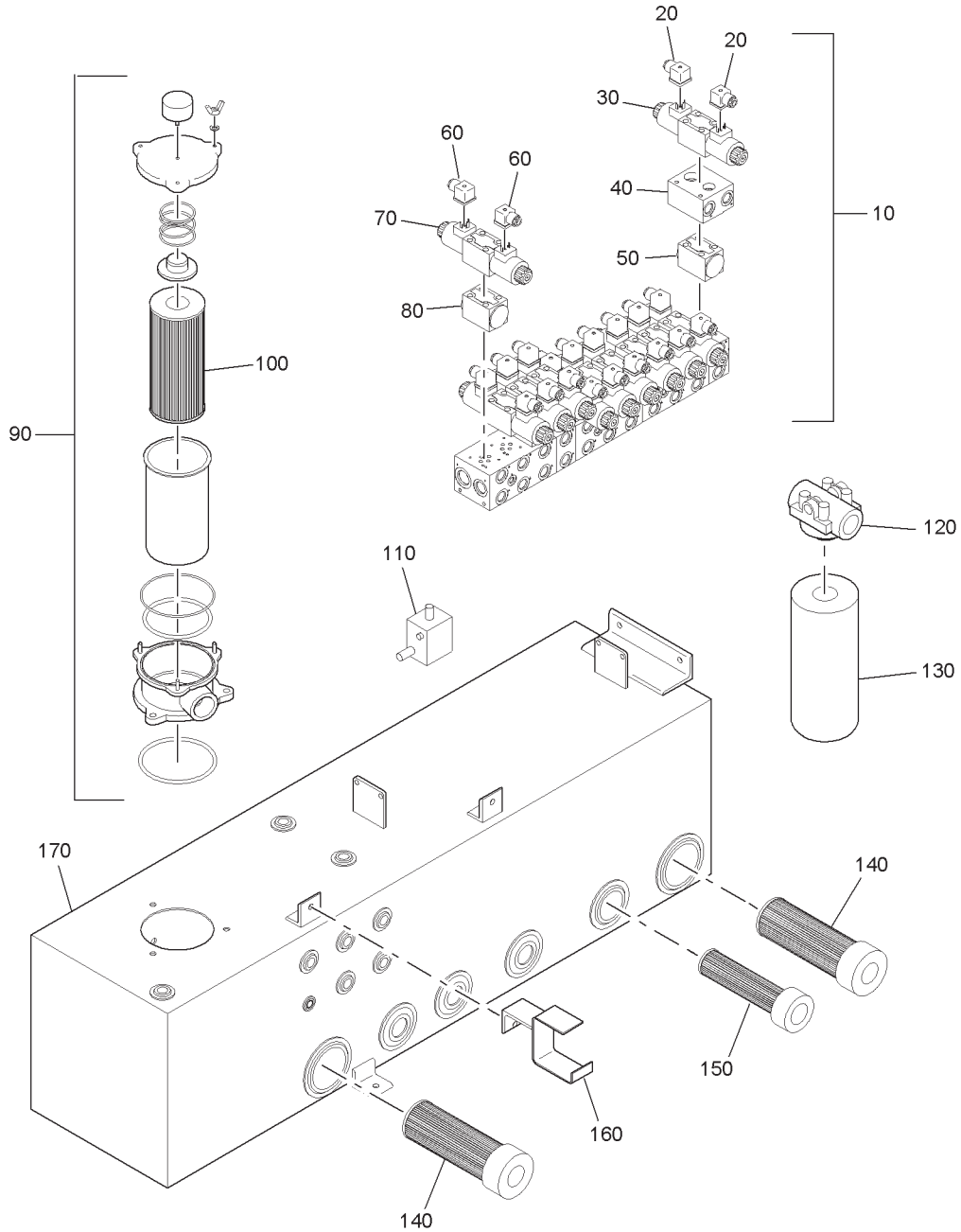

FIGURE 32. HYDRAULIC COMPONENTS

FIGURE 32. HYDRAULIC COMPONENTS

FIG ITEM	PART NUMBER	NOMENCLATURE							UNITS PER ASSY
		1	2	3	4	5	6	7	
32									
-1	TBD	HYDRAULIC COMPONENTS							REF
10	980440	• MANIFOLD ASSEMBLY, MAIN VALVE BANK							1
20	851532	•• DEN CONNECTOR							2
30	980440-04	•• VALVE ASSEMBLY							1
40	980440-01	•• VICKERS FLOW DIVIDE							1
50	980440-03	•• LOAD CHECK VALVE							1
60	851532	•• DEN CONNECTOR							2
70	980440-05	•• COIL, 12V SOLENOID							1
80	980440-02	•• VALVE, CHECK							1
90	982940	• FILTER HOUSING ASSEMBLY, HYDRAULIC							1
100	982941	•• FILTER ELEMENT, HYDRAULIC							1
110	981070	• TRACK TENSIONER, W/ REDUCING							1
120	981918	• HEAD, HYDRAULIC CHARGE/RETURN FILTER							1
130	981917	• FILTER ELEMENT, HYDRAULIC CHARGE							1
140	980630	• STRAINER, HYDRAULIC SUCTION							2
150	980560	• STRAINER, HYDRAULIC SUCTION							1
160	981605	• BRACKET, WIREHOLDER							2
170	980174	• HYDRAULIC TANK							1

NP = NOT PROCURABLE

- ITEM NOT ILLUSTRATED

ILLUSTRATED PARTS LIST

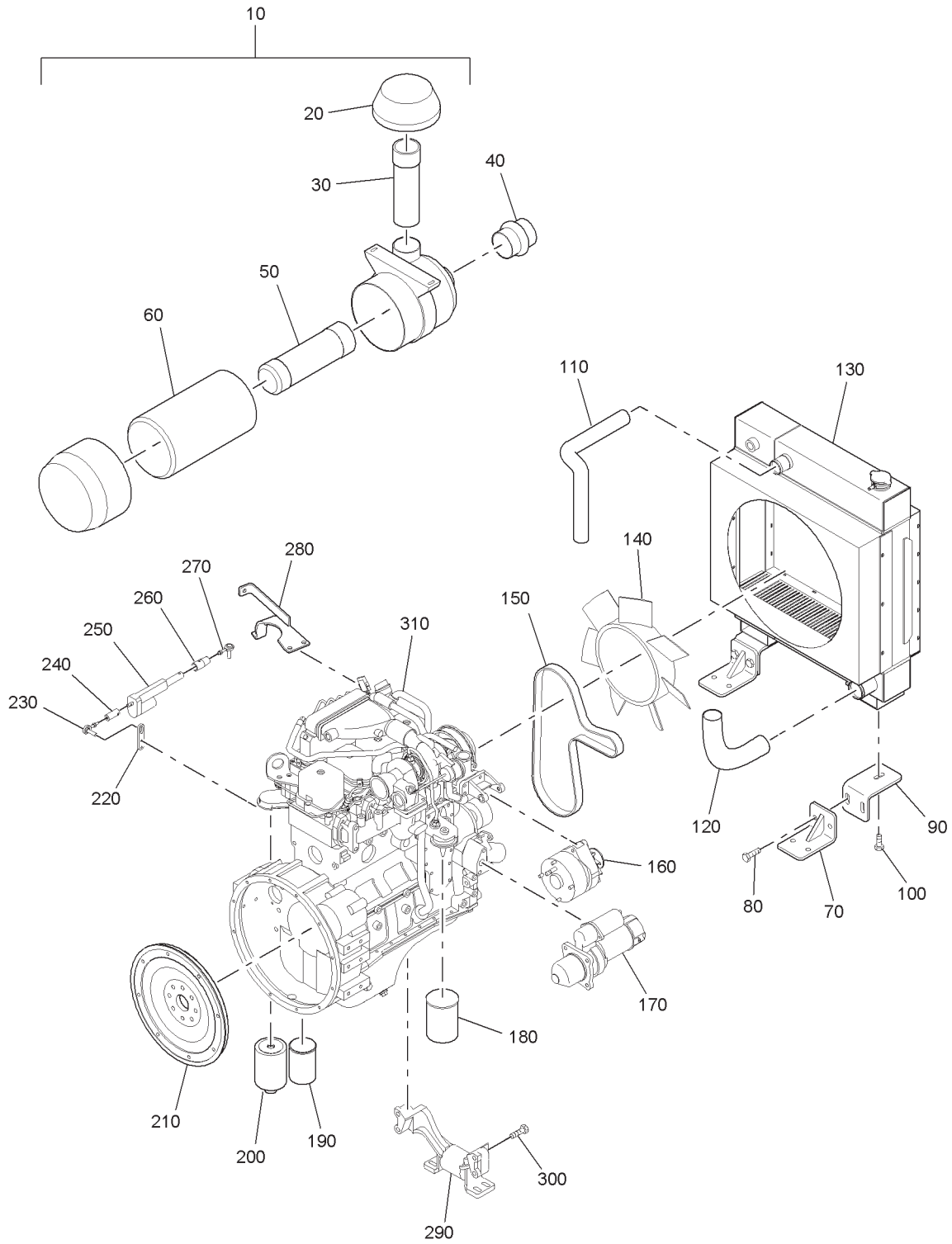

FIGURE 33. ENGINE COMPONENTS

FIGURE 33. ENGINE COMPONENTS

FIG ITEM	PART NUMBER	NOMENCLATURE	UNITS PER ASSY
33			
-1	TBD	ENGINE COMPONENTS	REF
10	980450	• AIR CLEANER ASSEMBLY	1
20	38467	•• AIR CLEANER HOOD	REF
30	981523	•• AIR CLEANER PIPE	REF
40	8535211370	•• AIR CLEANER END CAP	1
50	981520	• FILTER, INNER AIR	1
60	981519	• FILTER, OUTER AIR	1
70	981705	• MOUNTING BRACKET	2
		ATTACHING PARTS	
80	102-406-1A	• SCREW, 1/2" - 13 X 1.25 HEX CAP	2
		-----*-----	
90	981704	• MOUNTING BRACKET	1
		ATTACHING PARTS	
100	104-407-1A	• SCREW, 1/2"- 13 X 1.5 FLAT HEAD	2
		-----*-----	
-101	981937	• INLINE FUEL FILTER	1
110	170071A	• UPPER RADIATOR HOSE	1
120	170100A	• LOWER RADIATOR HOSE	1
130	980280	• RADIATOR ASSEMBLY	1
140	983454	• FAN, RADIATOR	1
150	160200	• BELT, SERPENTINE	1
160	160220	• ALTERNATER	1
170	160310	• SOLENOID ASSEMBLY	1
180	160180	• FILTER, OIL	1
190	160170	• FILTER, FUEL SECONDARY	1
200	160160	• FILTER, FUEL PRIMARY	1
210	P86879B	• PUMP DRIVE PLATE, FLYWHEEL	1
220	980338	• BRACKET, REAR, ELECTRIC SCREW	1

NP = NOT PROCURABLE
 - ITEM NOT ILLUSTRATED

**This Page
Intentionally
Left Blank**

FIGURE 33. ENGINE COMPONENTS (CONTINUED)

FIG ITEM	PART NUMBER	NOMENCLATURE							UNITS PER ASSY
		1	2	3	4	5	6	7	
33									
230	982157	• LINKAGE, THROTTLE							1
240	980318	• CONNECTOR, REAR, ELECTRIC SCREW							1
250	320130	• ELECTRIC SCREW							1
260	980317	• CONNECTOR, FRONT, ELECTRIC SCREW							1
270	982157	• LINKAGE, THROTTLE							1
280	985002	• BRACKET, FRONT, ELECTRIC SCREW							1
290	160270	• BRACKET, ENGINE MOUNT							1
-291	980620-02	• SWITCH, FUEL SHUTOFF							1
		ATTACHING PARTS							
300	104-407-1A	• SCREW, 1/2" - 13 X 1.5 HEX CAP							4
		-----*							
310	980620	• ENGINE, CUMMINS							

NP = NOT PROCURABLE

- ITEM NOT ILLUSTRATED

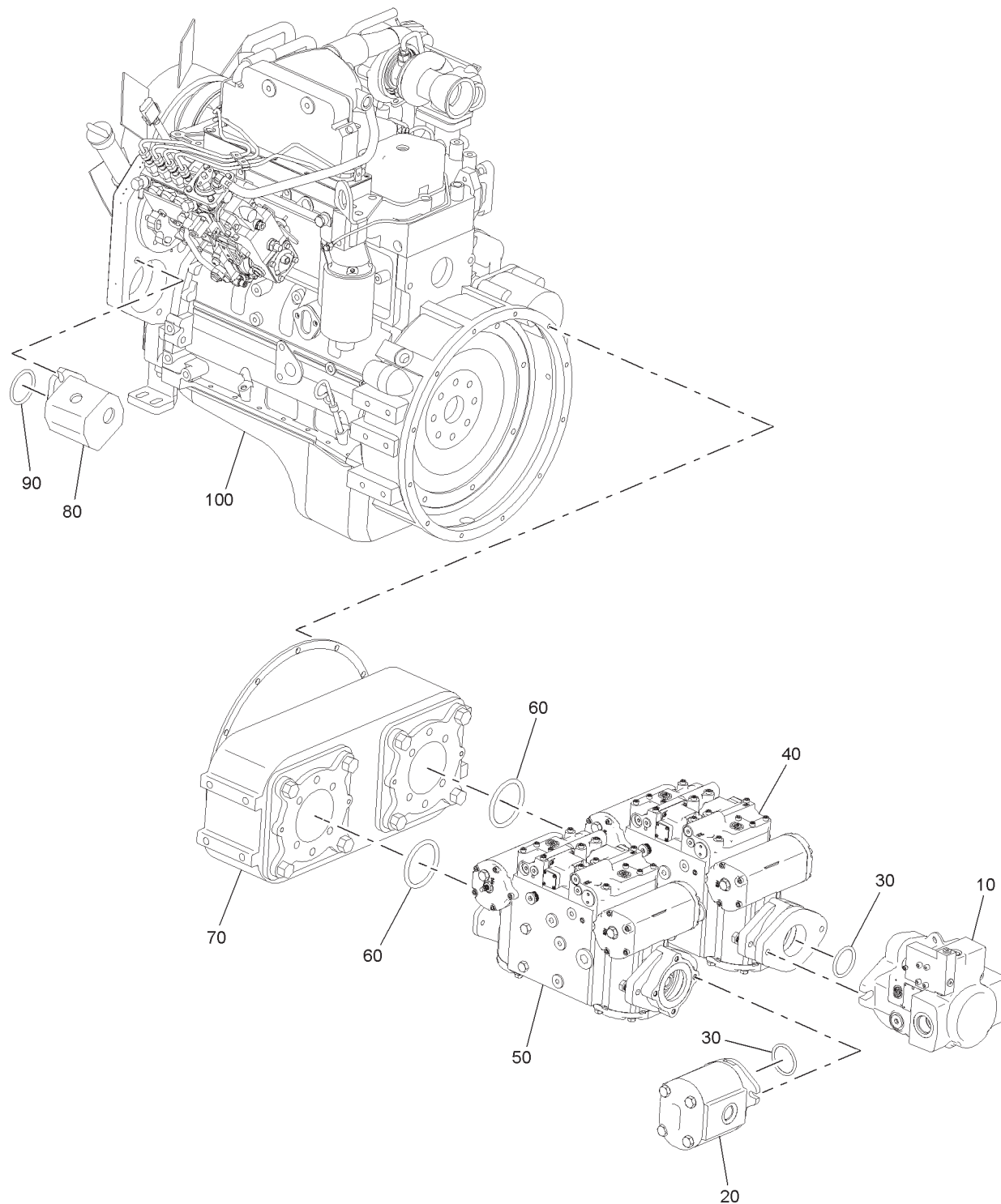

FIGURE 34. HYDRAULIC PUMPS

FIGURE 34. HYDRAULIC PUMPS

FIG ITEM	PART NUMBER	NOMENCLATURE							UNITS PER ASSY
		1	2	3	4	5	6	7	
34									
-1	TBD	HYDRAULIC PUMPS							REF
10	980490	• PUMP, PRESSURE COMP.							1
20	980500	• PUMP, VARIABLE CHARGE							1
30	984993	• O-RING							2
40	980470	• PUMP, VARIABLE AUGER/CONVEYOR							1
50	980470	• PUMP, VARIABLE AUGER/CONVEYOR							1
60	984992	• O-RING							2
70	980400	• PUMP, DOUBLE DRIVE							1
80	980510	• PUMP, FAN DRIVE							1
90	984991	• O-RING							1
100	980620	• ENGINE, CUMMINS 4 CYL TURBO							1

NP = NOT PROCURABLE

- ITEM NOT ILLUSTRATED

ILLUSTRATED PARTS LIST

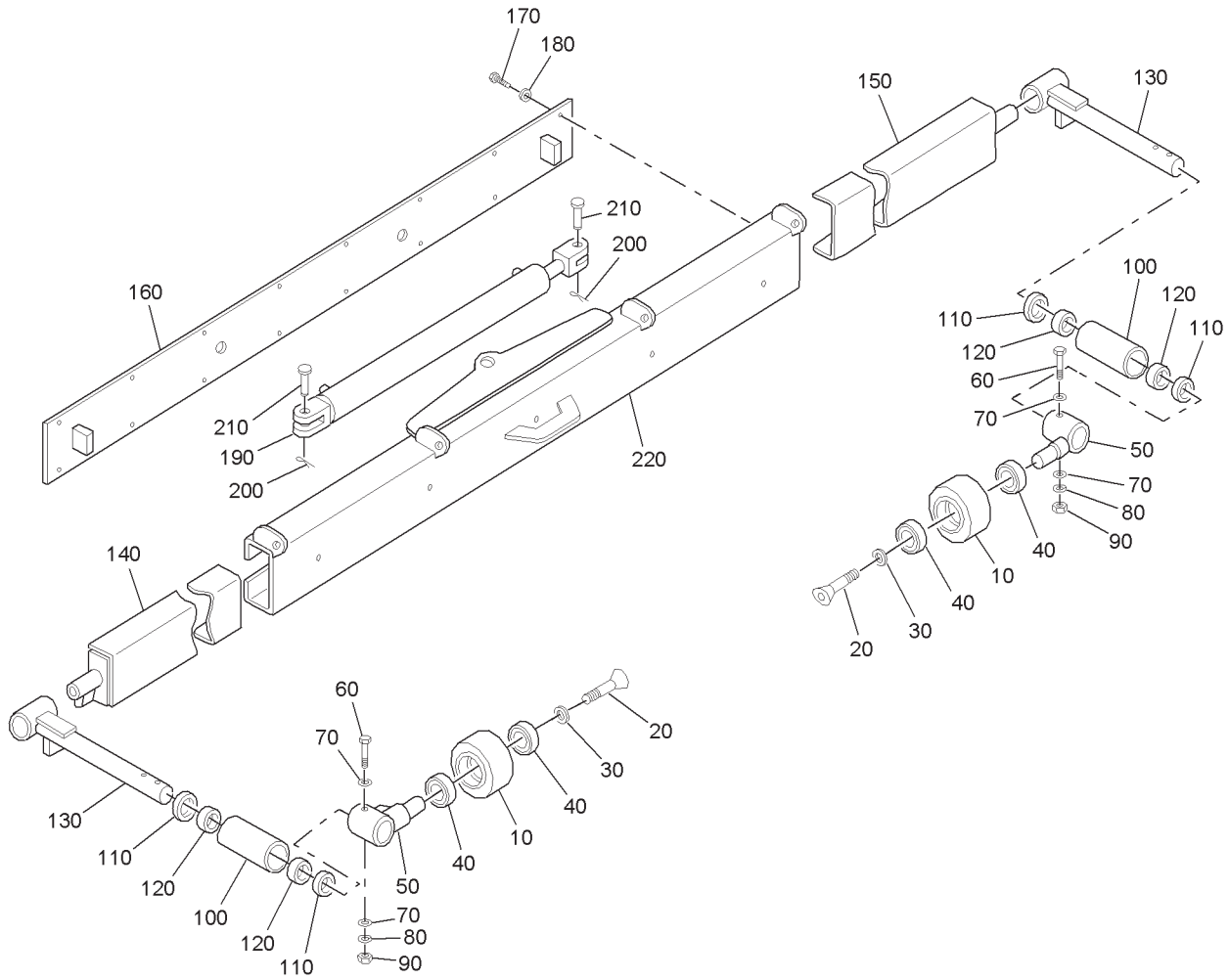

FIGURE 35. TRUCK HITCH ASSEMBLY

FIGURE 35. TRUCK HITCH ASSEMBLY

FIG ITEM	PART NUMBER	NOMENCLATURE							UNITS PER ASSY
		1	2	3	4	5	6	7	
35									
-1	TBD	TRUCK HITCH ASSEMBLY							REF
10	930055	• GUIDE WHEEL, TRUCK HITCH							2
		ATTACHING PARTS							
20	851111	• SCREW, 1/2" - 13 X 2.0 HEX CAP, FLAT HEAD							1
30	851112	• WASHER, 1/2" FLAT							1
		-----*							
40	930050	• BEARING, TRUCK HITCH ROLLER							4
50	930045	• AXLE, GUIDE WHEEL							2
		ATTACHING PARTS							
60	102-615-1A	• SCREW, 5/8" - 11 X 3.5 HEX CAP							1
70	120-7	• WASHER, 5/8" FLAT							2
80	118-7	• WASHER, 5/8" FLAT LOCK							1
90	115-7	• NUT, 5/8" HEX							1
		-----*							
100	930040	• ROLLER							2
		ATTACHING PARTS							
110	620400	• COLLAR, LOCK							2
120	810070	• BUSHING, TRACK IDLER/TRUCK HITCH							2
		-----*							
130	930030	• GUIDE, WHEEL PIVOT ARM							2
140	930020	• ARM EXTENSION, LH							1
150	930025	• ARM EXTENSION, RH							1
160	930065	• COVER, BACK PANEL							1

NP = NOT PROCURABLE
 - ITEM NOT ILLUSTRATED

**This Page
Intentionally
Left Blank**

FIGURE 35. TRUCK HITCH ASSEMBLY (CONTINUED)

FIG ITEM	PART NUMBER	NOMENCLATURE							UNITS PER ASSY
		1	2	3	4	5	6	7	
35									
		ATTACHING PARTS							
170	102-203-1A	• SCREW, 3/8" - 16 X 0.5 HEX CAP							16
180	118-3	• WASHER, 3/8" FLAT							16
		-----*							
190	930070	• CYLINDER, ARM EXTENSION							1
192	851481	• SEAL KIT							1
		ATTACHING PARTS							
200	930039	• PIN, COTTER							2
210	210060	• PIN, CLEVIS							2
		-----*							
220	982178	• WELDMENT, TRUCK HITCH							1

NP = NOT PROCURABLE
 - ITEM NOT ILLUSTRATED

ILLUSTRATED PARTS LIST

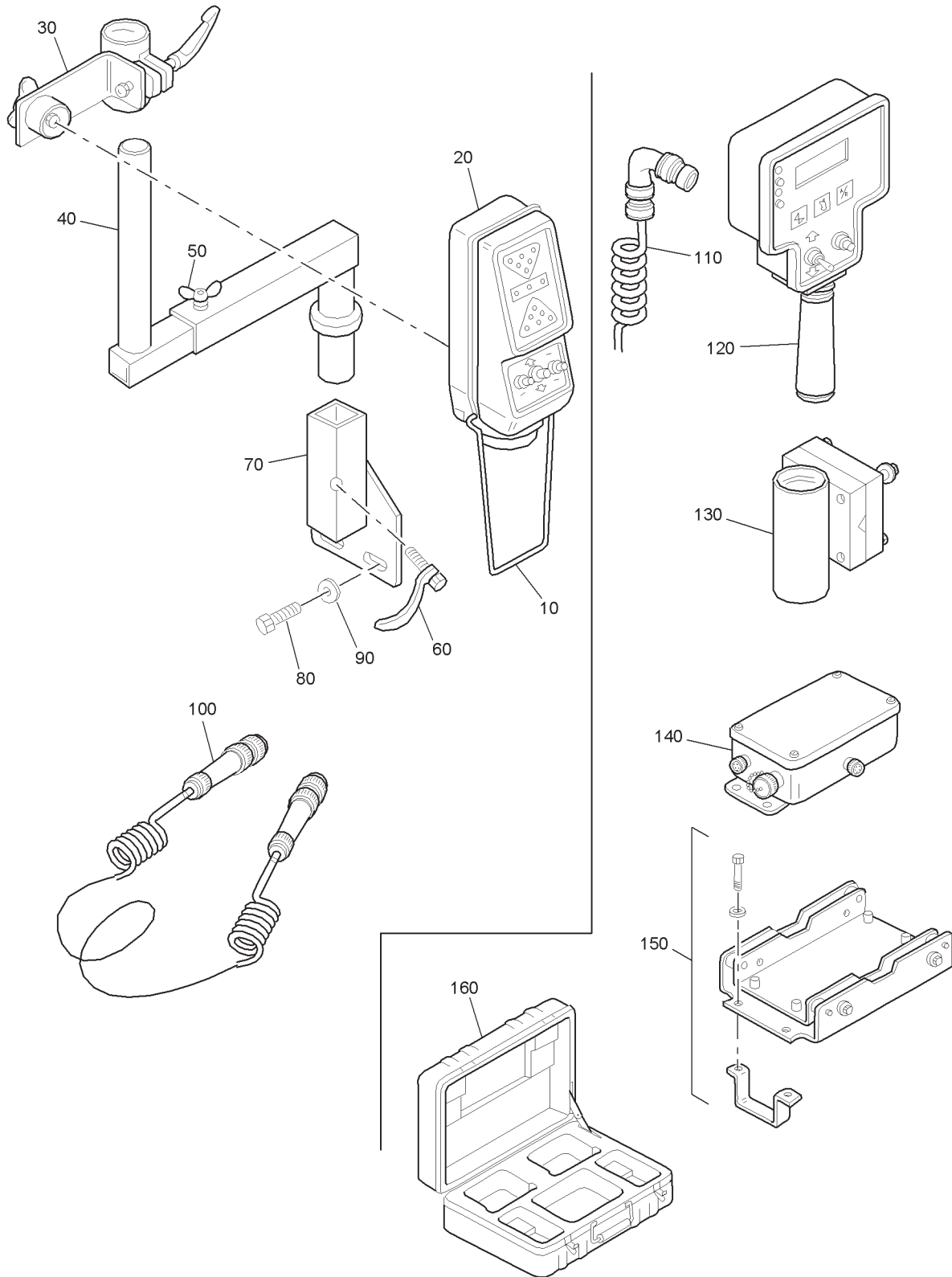

FIGURE 36. PAVER GRADE CONTROLS SPECTRA PHYSICS

FIGURE 36. PAVER GRADE CONTROLS SPECTRA PHYSICS

FIG ITEM	PART NUMBER	NOMENCLATURE							UNITS PER ASSY
		1	2	3	4	5	6	7	
36									
-1	TBD	PAVER GRADE CONTROLS SPECTRA PHYSICS							REF
10	4956S-01	• BAIL WIRE							1
20	851422	• SONIC TRACER							1
30	851631	• BRACKET, TRACER							1
40	851423	• Z BRACKET ARM, 1.75"							1
		ATTACHING PARTS							
50	920070	• WINGBOLT, 3/8"							1
		-----*-----							
60	300060	• HANDLE, BOLT							1
70	851575	• MOUNT, PIVOT							1
		ATTACHING PARTS							
80	102-606-1A	• SCREW, 5/8" - 11 X 1.0 HEX CAP							2
90	119-7	• WASHER. 5/8" FLAT							2
		-----*-----							
100	982019	• COILED CORD, TRACER/SLOPE							1
110	851630	• COILED CORD, R-25 REMOTE							1
120	851426	• UNIVERSAL REMOTE							1
130	851687	• BRACKET, REMOTE							1
140	851430	• SLOPE MODULE, SCREED							1
150	851425	• SHOCK MOUNT, SLOPE							1
160	851265	• CASE, SONIC TRACKER							1

NP = NOT PROCURABLE
 - ITEM NOT ILLUSTRATED

ILLUSTRATED PARTS LIST

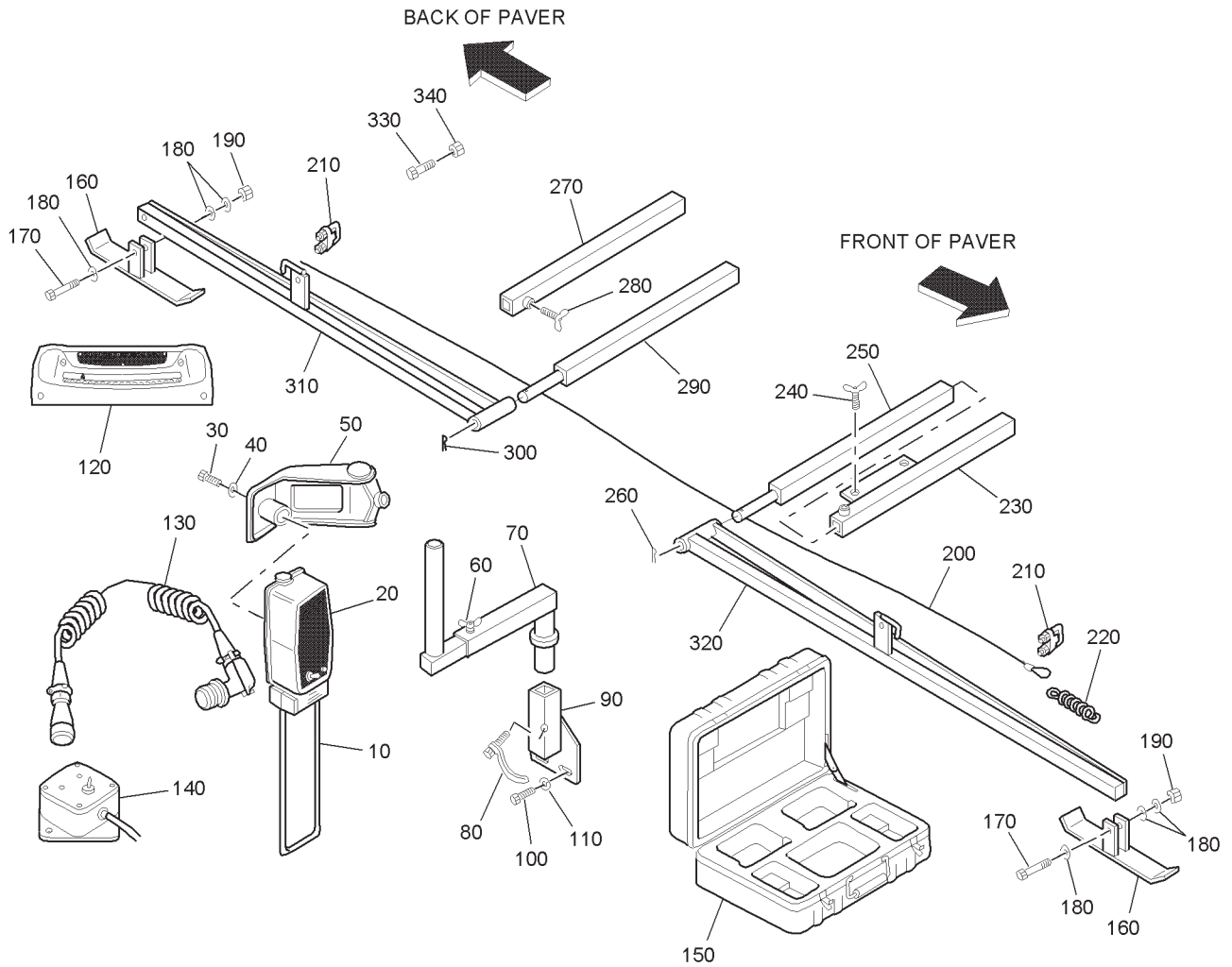

FIGURE 37. PAVER LEVELING CONTROL

FIGURE 37. PAVER LEVELING CONTROL

FIG ITEM	PART NUMBER	NOMENCLATURE	UNITS PER ASSY
37			
-1	TBD	PAVER LEVELING CONTROL	REF
10	851581	• BAIL WIRE, TEMPERATURE	1
20	851579	• SONIC TRACER	1
		ATTACHING PARTS	
30	102-617-1A	• SCREW, 5/8" - 11 X 4.0 HEX CAP	1
40	119-7	• WASHER. 5/8" FLAT	1
		-----*-----	
50	851578	• BRACKET, TRACER	1
60	920070	• WINGBOLT, 3/8"	1
70	9090-1125	• Z BRACKET ARM	1
		ATTACHING PARTS	
80	300060	• HANDLE, BOLT	1
		-----*-----	
90	851575	• MOUNT, PIVOT	2
		ATTACHING PARTS	
100	102-606-1A	• SCREW, 5/8" - 11 X 1.0 HEX CAP	2
110	119-7	• WASHER. 5/8" FLAT	2
		-----*-----	
120	851421	• SLOPE METER	1
130	851574	• COILED CORD, TRACER/SLOPE	1
140	851580	• A/M/ MODULE & CABLE ASSEMBLY	1
150	851265	• CASE, SONIC TRACKER	1
160	851249	• SKID	2

NP = NOT PROCURABLE
 - ITEM NOT ILLUSTRATED

ILLUSTRATED PARTS LIST



FIGURE 37. PAVER LEVELING CONTROL (CONTINUED)

FIG ITEM	PART NUMBER	NOMENCLATURE							UNITS PER ASSY
		1	2	3	4	5	6	7	
37									
		ATTACHING PARTS							
170	102-411-1A	• SCREW, 1/2" - 13 X 2.5 HEX CAP							1
180	119-5	• WASHER, 1/2" FLAT							3
190	143-5	• NUT, 1/2" HEX LOCK							1
		-----*							
200	851246	• CABLE 1 1/16"							1
		ATTACHING PARTS							
210	851244	• CLAMP U-BOLT							2
		-----*							
220	851245	• SPRING, TENSION							1
230	851241	• HOUSING, REAR SLIDE BAR							2
		ATTACHING PARTS							
240	920070	• WINGBOLT, 3/8"							1
		-----*							
250	851242	• BAR, ADJUSTABLE SLIDE							1
		ATTACHING PARTS							
260	930039	• PIN, COTTER							1
		-----*							
270	851243	• HOUSING, FRONT SLIDE BAR							1
		ATTACHING PARTS							
280	920070	• WINGBOLT, 3/8"							1

NP = NOT PROCURABLE
 - ITEM NOT ILLUSTRATED

FIGURE 37. PAVER LEVELING CONTROL (CONTINUED)

FIG ITEM	PART NUMBER	NOMENCLATURE	UNITS PER ASSY
37			
290	851242	• BAR, ADJUSTABLE SLIDE	1
		ATTACHING PARTS	
300	930039	• PIN, COTTER	1
		-----*	
310	851248	• SUPPORT, ARM SKID (FRONT)	1
320	851247	• SUPPORT, ARM SKID (REAR)	1
330	102-709-1A	• SCREW, 3/4" - 15 - 2.0 HEX	1
340	119-8	• WASHER, 3/4" - FLAT	1

NP = NOT PROCURABLE
 - ITEM NOT ILLUSTRATED

VIEW FROM BEHIND (UNDER) MAIN DASH ASSEMBLY

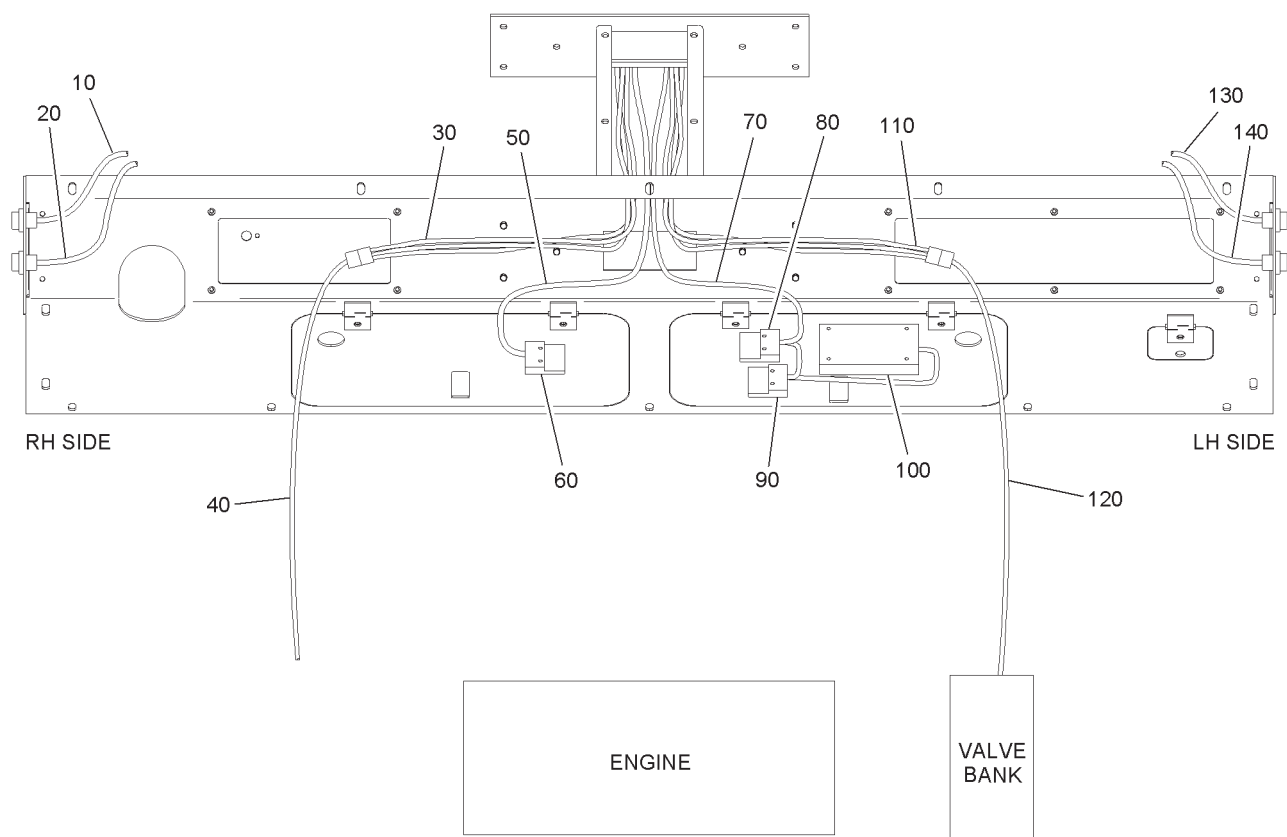

FIGURE 38. MAIN HARNESS WIRING

FIGURE 38. MAIN HARNESS WIRING

FIG ITEM	PART NUMBER	NOMENCLATURE							UNITS PER ASSY
		1	2	3	4	5	6	7	
38									
-1	980640	MAIN HARNESS WIRING							REF
10	851629	• SPECTRA CONTROL WIRING							1
20	980550	• AUGER SENSOR WIRING							1
30	983008	• WIRE HARNESS, DASH, RIGHT							1
40	982742	• WIRE HARNESS, AUXILLARY							1
50	980975	• WIRE HARNESS, PROPEL							1
60	980530	• MICRO CONTROLLER, RH							1
70	980975	• WIRE HARNESS, PROPEL							1
80	851547	• MICRO CONTROLLER, ELECTRONIC							1
90	851547	• MICRO CONTROLLER, ELECTRONIC							1
100	852090	• JUNCTION BOX, ELECTRONIC, STEERING							1
110	982943	• WIRE HARNESS, DASH, LEFT							1
120	982741	• WIRE HARNESS, HYDRAULICS							1
130	851629	• SPECTRA CONTROL WIRING							1
140	980550	• AUGER SENSOR WIRING							1

NP = NOT PROCURABLE
 - ITEM NOT ILLUSTRATED

ILLUSTRATED PARTS LIST



INDEX BY PART DESCRIPTION

FIG ITEM	PART NUMBER.	NOMENCLATURE 123456	PAGE
140	851580	• A/M/ MODULE & CABLE ASSEMBLY	IPL-123
120	230250	• ADAPTER	IPL-57
390	230250	• ADAPTER	IPL-59
160	981994	• ADJUSTER ASSEMBLY, EXTENSION	IPL-51
110	984621	• ADJUSTER ASSEMBLY, LOWER TILT	IPL-51
10	980261-01	• ADJUSTER ASSEMBLY, UPPER TILT	IPL-51
160	38467	• AIR BREATHER COVER	IPL-76
10	980450	• AIR CLEANER ASSEMBLY	IPL-111
40	8535211370	• AIR CLEANER END CAP	IPL-111
20	38467	• AIR CLEANER HOOD	IPL-111
30	981523	• AIR CLEANER PIPE	IPL-111
160	160220	• ALTERNATER	IPL-111
-11	980953L	• ANGLE PLATE. LH	IPL-69
10	980953R	• ANGLE PLATE. RH	IPL-69
140	930020	• ARM EXTENSION, LH	IPL-117
150	930025	• ARM EXTENSION, RH	IPL-117
120	980787	• ARM, PUSH BLOCK	IPL-95
90	980076	• ASSEMBLY, BOGIE ROLLER	IP-101
110	980019	• ASSEMBLY, BOGIE SHAFT	IP-101
190	980019	• ASSEMBLY, BOGIE SHAFT	IPL-102
60	980100	• ASSEMBLY, BOGIE WHEEL	IP-101
140	980100	• ASSEMBLY, BOGIE WHEEL	IPL-102
280	980100	• ASSEMBLY, BOGIE WHEEL	IPL-103
90	980106	• ASSEMBLY, CONVEYOR DRIVE ADJUSMENT	IPL-85
410	983629	• ASSEMBLY, FRAME	IPL-103
270	984346	• ASSEMBLY, FRONT IDLER W/ BLOCK	IPL-102
80	980174	• ASSEMBLY, HYDRAULIC TANK	IPL-81
170	980075	• ASSEMBLY, IDLER BOGIE ROLLER	IPL-102
-40	853941	• ASSEMBLY, LPG BOTTLE HOLDER	IPL-5
-120	853941	• ASSEMBLY, LPG BOTTLE HOLDER	IPL-5
150	980027	• ASSEMBLY, PUSH BAR MOUNT	IPL-95
10	980444	• ASSEMBLY, STAIRWAY (SEE FIG 15 FOR BREAKDOWN)	IPL-5
50	980172	• ASSY, CITRUS TANK	IPL-81
20	980176	• ASSY, FUEL TANK	IPL-81
460	980149	• AUGER ASSEMBLY, 8816	IPL-67
20	980550	• AUGER SENSOR WIRING	IPL-127
140	980550	• AUGER SENSOR WIRING	IPL-127
50	930045	• AXLE, GUIDE WHEEL	IPL-117
10	4956S-01	• BAIL WIRE	IPL-121
10	851581	• BAIL WIRE, TEMPERATURE	IPL-123
250	851242	• BAR, ADJUSTABLE SLIDE	IPL-124
290	851242	• BAR, ADJUSTABLE SLIDE	IPL-125
120	981331	• BAR, BOTTOM FLIGHT MOUNT	IPL-7
120	981331	• BAR, BOTTOM FLIGHT MOUNT	IPL-11
40	980259	• BAR, EXTENSION RAIL	IPL-31
40	980259	• BAR, EXTENSION RAIL	IPL-33
280	980278	• BAR, FRONT RUBBER MOUNT	IPL-89
240	980056	• BAR, IDLER SIDE TAPPED	IPL-102
10	980244L	• BAR, LH EXTENSION RAIL	IPL-33
80	980232	• BAR, PIVOT	IPL-35
80	980232	• BAR, PIVOT	IPL-39
190	856954	• BAR, PUSH BAR PIN	IPL-97
10	980244R	• BAR, RH EXTENSION RAIL	IPL-31
220	980366	• BAR, ROUND	IPL-76
200	980365	• BAR, ROUND BENT	IPL-76
120	980042	• BAR, ROUND SIDEWING HINGE	IPL-87
240	980042	• BAR, ROUND SIDEWING HINGE	IPL-88
50	980458	• BAR, TILT SCREW HOLDDOWN	IPL-47
70	981332	• BAR, TOP FLIGHT MOUNT	IPL-7

INDEX BY PART DESCRIPTION CONT..

FIG ITEM	PART NUMBER.	NOMENCLATURE 123456	PAGE
70	981332	• BAR, TOP FLIGHT MOUNT	IPL-11
190	980424	• BAR, WALKBOARD, HINGE MOUNT	IPL-37
190	980424	• BAR, WALKBOARD, HINGE MOUNT	IPL-41
320	920152	• BATTERY	IP-83
330	980595	• BATTERY TRAY	IP-83
100	980376	• BEACON LIGHT MOUNT ASSEMBLY	IPL-75
50	850130	• BEARING	IPL-95
100	850130	• BEARING	IPL-95
50	870030	• BEARING BLOCK	IPL-51
110	810070	• BEARING RING, INNER	IPL-15
300	980335	• BEARING SUPPORT, AUGER	IPL-67
390	420090	• BEARING, 400 FRONT AXLE/7000	IPL-67
130	981328	• BEARING, FLIGHT SCREW PIVOT	IPL-7
130	981328	• BEARING, FLIGHT SCREW PIVOT	IPL-11
310	850130	• BEARING, FRONT AXLE HOUSING	IPL-93
340	850130	• BEARING, FRONT AXLE HOUSING	IPL-93
200	810070	• BEARING, PUSH BAR PIN	IPL-97
240	850130	• BEARING, REAR AXLE HOUSING	IPL-92
270	850130	• BEARING, REAR AXLE HOUSING	IPL-92
40	930050	• BEARING, TRUCK HITCH ROLLER	IPL-117
150	160200	• BELT, SERPENTINE	IPL-111
-211	981742	• BLANK FLIGHT	IPL-66
100	980520	• BLOCK	IPL-65
30	102-409-1A	• BOLT, 1/2" - 13 X 2.0 HEX	IPL-19
30	102-409-1A	• BOLT, 1/2" - 13 X 2.0 HEX	IPL-21
60	102-305-1A	• BOLT, 7/16" - 14 X 1.0 HEX	IPL-19
60	102-305-1A	• BOLT, 7/16" - 14 X 1.0 HEX	IPL-21
230	980235L	• BOTTOM ASSEMBLY, LEFT-HAND EXTENSION	IPL-53
-240	980235R	• BOTTOM ASSEMBLY, RIGHT-HAND EXTENSION	IPL-53
150	980466	• BOTTOM BAR, END GATE	IPL-47
140	855262L	• BOTTOM BRACKET, LH SCREW	IPL-47
-141	855262R	• BOTTOM BRACKET, RH SCREW	IPL-47
190	984971	• BRACE ASSEMBLY, DASH	IPL-63
140	981454	• BRACKET	IPL-7
140	981454	• BRACKET	IPL-11
50	550108	• BRACKET, BURNER	IPL-57
320	550108	• BRACKET, BURNER	IPL-59
290	160270	• BRACKET, ENGINE MOUNT	IPL-113
280	985002	• BRACKET, FRONT, ELECTRIC SCREW	IPL-113
220	980338	• BRACKET, REAR, ELECTRIC SCREW	IPL-111
130	851687	• BRACKET, REMOTE	IPL-121
50	851578	• BRACKET, TRACER	IPL-123
30	851631	• BRACKET, TRACER	IPL-121
160	981605	• BRACKET, WIREHOLDER	IPL-109
-1	TBD	• BURNER ASSEMBLY, FOUR-WAND (SEE FIG 1 FOR NHA)	IPL-57
450	983437	• BURNER WAND	IPL-59
180	983437	• BURNER WAND EXTENSION ASSEMBLY	IPL-57
220	982502	• BURNER, ASSEMBLY IGNITER	IPL-57
490	982502	• BURNER, ASSEMBLY IGNITER	IPL-59
230	982504	• BURNER, ASSEMBLY MAIN	IPL-57
240	982504	• BURNER, ASSEMBLY MAIN	IPL-57
500	982504	• BURNER, ASSEMBLY MAIN	IPL-59
510	982504	• BURNER, ASSEMBLY MAIN	IPL-59
110	810070	• BUSHING	IPL-17
140	982092	• BUSHING, 1"	IPL-15
140	982092	• BUSHING, 1"	IPL-17
242	980123	• BUSHING, AUGER HANGER	IPL-66
100	980170	• BUSHING, BOGIE ROLLER	IP-101
180	980170	• BUSHING, BOGIE ROLLER	IPL-102

ILLUSTRATED PARTS LIST



INDEX BY PART DESCRIPTION CONT..

FIG ITEM	PART NUMBER.	NOMENCLATURE 123456	PAGE
150	854047	• BUSHING, CURBER FLIGHT SCREW BOTTOM	IPL-51
90	980370	• BUSHING, PIVOT MOUNT	IPL-35
90	980370	• BUSHING, PIVOT MOUNT	IPL-39
80	980360	• BUSHING, SLIDE	IPL-31
80	980360	• BUSHING, SLIDE	IPL-33
120	810070	• BUSHING, TRACK IDLER/TRUCK HITCH	IPL-117
200	851246	• CABLE 1 1/16"	IPL-124
122	100-406-1A	• CAP SCREW, 1/2" - 13 X 1.25	IPL-85
360	102-407-1A	• CAP SCREW, 1/2" - 13 X 1.5 HEX CAP	IPL-77
350	110-419	• CAP SCREW, 1/2" - 13 X 4-1/2" SOCKET HEAD	IPL-67
220	102-5-1A	• CAP SCREW, 1/4" - 20 X 1" HEX	IPL-82
80	920070	• CAP SCREW, 7/16" - 14 X 1.25 HEX CAP, THUMB	IPL-75
10	982033	• CAP, FUEL, LOCKABLE	IPL-81
130	102-925-1A	• CAPSCREW, 1" - 8 X 6.0 HEX	IPL-15
130	102-925-1A	• CAPSCREW, 1" - 8 X 6.0 HEX	IPL-17
20	102-909-1A	• CAPSCREW, 1.0" - 8 X 2.0 HEX	IPL-45
124	110-409-1A	• CAPSCREW, 1/2" - 13 - 2.0 HEX	IPL-15
124	110-409-1A	• CAPSCREW, 1/2" - 13 - 2.0 HEX	IPL-17
130	102-404-1A	• CAPSCREW, 1/2" - 13 X 0.75 HEX	IPL-19
130	102-404-1A	• CAPSCREW, 1/2" - 13 X 0.75 HEX	IPL-21
20	102-405-1A	• CAPSCREW, 1/2" - 13 X 1 HEX	IPL-5
50	102-405-1A	• CAPSCREW, 1/2" - 13 X 1 HEX	IPL-5
130	102-405-1A	• CAPSCREW, 1/2" - 13 X 1 HEX	IPL-5
60	102-406-1A	• CAPSCREW, 1/2" - 13 X 1.25 HEX	IPL-45
20	102-407-1A	• CAPSCREW, 1/2" - 13 X 1.5 HEX	IPL-31
50	102-407-1A	• CAPSCREW, 1/2" - 13 X 1.5 HEX	IPL-31
20	102-407-1A	• CAPSCREW, 1/2" - 13 X 1.5 HEX	IPL-33
50	102-407-1A	• CAPSCREW, 1/2" - 13 X 1.5 HEX	IPL-33
200	102-409-1A	• CAPSCREW, 1/2" - 13 X 2.0 HEX	IPL-37
200	102-409-1A	• CAPSCREW, 1/2" - 13 X 2.0 HEX	IPL-41
80	102-705-1A	• CAPSCREW, 3/4" - 10 X 1.0 HEX	IPL-23
80	102-705-1A	• CAPSCREW, 3/4" - 10 X 1.0 HEX	IPL-25
20	102-707-1A	• CAPSCREW, 3/4" - 10 X 1.5 HEX	IPL-23
50	102-707-1A	• CAPSCREW, 3/4" - 10 X 1.5 HEX	IPL-23
20	102-707-1A	• CAPSCREW, 3/4" - 10 X 1.5 HEX	IPL-25
50	102-707-1A	• CAPSCREW, 3/4" - 10 X 1.5 HEX	IPL-25
20	102-709-1A	• CAPSCREW, 3/4" - 10 X 2.0 HEX	IPL-27
50	102-709-1A	• CAPSCREW, 3/4" - 10 X 2.0 HEX	IPL-27
20	102-713-1A	• CAPSCREW, 3/4" - 10 X 3.0 HEX	IPL-35
20	102-713-1A	• CAPSCREW, 3/4" - 10 X 3.0 HEX	IPL-39
160	102-204-1A	• CAPSCREW, 3/8" - 16 X 0.75 HEX	IPL-9
160	102-204-1A	• CAPSCREW, 3/8" - 16 X 0.75 HEX	IPL-13
230	102-206-1A	• CAPSCREW, 3/8" - 16 X 1.25 HEX	IPL-9
230	102-206-1A	• CAPSCREW, 3/8" - 16 X 1.25 HEX	IPL-13
40	102-207-1A	• CAPSCREW, 3/8" - 16 X 1.5 HEX	IPL-7
40	102-207-1A	• CAPSCREW, 3/8" - 16 X 1.5 HEX	IPL-11
20	102-210-1A	• CAPSCREW, 3/8" - 16 X 2.25 HEX	IPL-43
70	102-210-1A	• CAPSCREW, 3/8" - 16 X 2.25 HEX	IPL-43
60	102-607-1A	• CAPSCREW, 5/8" - 11 X 1.5 HEX	IPL-35
60	102-607-1A	• CAPSCREW, 5/8" - 11 X 1.5 HEX	IPL-39
70	102-609-1A	• CAPSCREW, 5/8" - 11 X 2 HEX	IPL-15
70	102-609-1A	• CAPSCREW, 5/8" - 11 X 2 HEX	IPL-17
20	102-609-1A	• CAPSCREW, 5/8" - 11 X 2.0 HEX	IPL-55
20	102-619-1A	• CAPSCREW, 5/8" - 11 X 4.5 HEX	IPL-15
20	102-619-1A	• CAPSCREW, 5/8" - 11 X 4.5 HEX	IPL-17
130	102-304-1A	• CAPSCREW, 7/16" - 14 X 0.75 HEX	IPL-31
100	102-305-1A	• CAPSCREW, 7/16" - 14 X 1.0 HEX	IPL-19
100	102-305-1A	• CAPSCREW, 7/16" - 14 X 1.0 HEX	IPL-21
40	102-305-1A	• CAPSCREW, 7/16" - 14 X 1.0 HEX	IPL-43

INDEX BY PART DESCRIPTION CONT..

FIG ITEM	PART NUMBER.	NOMENCLATURE 123456	PAGE
90	102-305-1A	• CAPSCREW, 7/16" - 14 X 1.0 HEX	IPL-43
120	102-305-1A	• CAPSCREW, 7/16" - 14 X 1.0 HEX	IPL-43
122	102-305-1A	• CAPSCREW, 7/16" - 14 X 1.0 HEX	IPL-43
120	102-306-1A	• CAPSCREW, 7/16" - 14 X 1.25 HEX	IPL-27
210	102-306-1A	• CAPSCREW, 7/16" - 14 X 1.25 HEX	IPL-29
110	102-307-1A	• CAPSCREW, 7/16" - 14 X 1.5 HEX	IPL-35
160	102-307-1A	• CAPSCREW, 7/16" - 14 X 1.5 HEX	IPL-37
110	102-307-1A	• CAPSCREW, 7/16" - 14 X 1.5 HEX	IPL-39
160	102-307-1A	• CAPSCREW, 7/16" - 14 X 1.5 HEX	IPL-41
80	102-312-1A	• CAPSCREW, 7/16" - 14 X 2.75 HEX	IPL-7
80	102-312-1A	• CAPSCREW, 7/16" - 14 X 2.75 HEX	IPL-11
-98	980520-01	• CARTRIDGE, VALVE	IPL-65
160	851265	• CASE, SONIC TRACKER	IPL-121
150	851265	• CASE, SONIC TRACKER	IPL-123
70	981020	• CHAIN	IPL-27
180	980680	• CHAIN ASSEMBLY, CONVEYOR	IPL-92
130	980079	• CHAIN GUARD, FRONT, CENTER	IPL-91
70	980044L	• CHAIN GUARD, FRONT, LH	IPL-91
10	980044R	• CHAIN GUARD, FRONT, RH	IPL-91
170	980087	• CHAIN GUARD, REAR	IPL-92
150	980099	• CHAIN GUARD, REAR, CENTER	IPL-92
100	980098L	• CHAIN GUARD, REAR, LH	IPL-91
40	980098R	• CHAIN GUARD, REAR, RH	IPL-91
40	981030	• CHAIN, #40R164	IPL-51
40	980220	• CHAIN, CONVEYOR	IPL-85
250	981069	• CHAINGUARD, FRONT	IPL-88
210	140430	• CIRCUIT BREAKER, INSTRUMENT	IPL-105
70	980285	• CITRUS COVER	IPL-75
430	980285	• CITRUS COVER	IPL-77
10	980416	• CLAMP	IPL-35
10	980416	• CLAMP	IPL-39
210	851244	• CLAMP U-BOLT	IPL-124
99	321330	• COIL	IPL-65
70	980440-05	• COIL, 12V SOLENOID	IPL-109
42	851548	• COILED CORD, ELECTRONIC	IPL-61
110	851630	• COILED CORD, R-25 REMOTE	IPL-121
130	851574	• COILED CORD, TRACER/SLOPE	IPL-123
100	982019	• COILED CORD, TRACER/SLOPE	IPL-121
110	620400	• COLLAR, LOCK	IPL-117
260	980317	• CONNECTOR, FRONT, ELECTRIC SCREW	IPL-113
240	980318	• CONNECTOR, REAR, ELECTRIC SCREW	IPL-113
110	980333	• CONTROL BOX, 8816 DASH	IPL-61
-1	TBD	• CONVEYOR ASSEMBLY	IPL-91
190	984979	• CONVEYOR FLOOR	IPL-92
70	880030	• COUPLING HALF, 1"	IPL-55
50	280030	• COUPLING HALF, VIBRATOR/TACK PUMP	IPL-55
200	230170	• COUPLING, 1/4" PIPE BRASS	IPL-57
470	230170	• COUPLING, 1/4" PIPE BRASS	IPL-59
90	854632	• COVER ASSEMBLY, DASH VANDALISM	IPL-61
50	980254	• COVER PLATE, PIVOT	IPL-35
50	980254	• COVER PLATE, PIVOT	IPL-39
280	980388	• COVER, ACCESS	IP-83
70	980128	• COVER, AUGER CHAIN BOTTOM	IPL-65
40	980336	• COVER, AUGER CHAIN TOP	IPL-65
160	930065	• COVER, BACK PANEL	IPL-117
210	981731	• COVER, HOOD EXHAUST MOTOR	IPL-82
410	980284	• COVER, SIDE	IPL-77
40	980182	• CROWN AND VALLEY ADJUSTMENT ASSEMBLY	IPL-27
380	980117	• CUTOFF ARM, INSIDE	IPL-67

ILLUSTRATED PARTS LIST



INDEX BY PART DESCRIPTION CONT..

FIG ITEM	PART NUMBER.	NOMENCLATURE 123456	PAGE
270	980138L	• CUTOFF ASSEMBLY, LEFT	IPL-66
-280	980138R	• CUTOFF ASSEMBLY, RIGHT	IPL-66
190	930070	• CYLINDER, ARM EXTENSION	IPL-119
430	981502	• CYLINDER, HYD	IPL-67
80	981503	• CYLINDER, HYD.	IPL-45
-11	85976	• DASH DECAL	IPL-5
-1	TBD	• DASHBOARD COMPONENTS	IPL-105
-282	859791	• DECAL KIT, 8816	IPL-105
-2	AG32222	• DECAL KIT, 8816, DECORATIVE	IPL-5
-4	859782	• DECAL KIT, 8816, WARNINGS	IPL-5
-120	859766	• DECAL, 8816, DASH	IPL-61
20	851532	• DEN CONNECTOR	IPL-109
60	851532	• DEN CONNECTOR	IPL-109
184	980690	• DRAG BAR ASSY, COMPLETE	IPL-92
180	851121	• DRIVE CHAIN, 8000C CONVEYOR	IPL-66
-1	TBD	• DRIVE CONVEYOR	IPL-85
320	854618	• DRIVE SHAFT, FRONT AXLE HOUSING	IPL-93
250	980151	• DRIVE SHAFT, REAR AXLE HOUSING	IPL-92
100	230083	• ELBOW, 90-DEGREE	IPL-57
370	230083	• ELBOW, 90-DEGREE	IPL-59
140	237826	• ELBOW, 90-DEGREE	IPL-57
410	237826	• ELBOW, 90-DEGREE	IPL-59
250	2515508	• ELBOW, 90-DEGREE	IPL-57
520	2515508	• ELBOW, 90-DEGREE	IPL-59
80	985109	• ELBOW, 90-DEGREE, 04FEM, 04JAC	IPL-57
160	985109	• ELBOW, 90-DEGREE, 04FEM, 04JAC	IPL-57
350	985109	• ELBOW, 90-DEGREE, 04FEM, 04JAC	IPL-59
430	985109	• ELBOW, 90-DEGREE, 04FEM, 04JAC	IPL-59
250	320130	• ELECTRIC SCREW	IPL-113
130	980256	• END CAP, CYLINDER MOUNT SHAFT	IPL-35
130	980256	• END CAP, CYLINDER MOUNT SHAFT	IPL-39
10	980456L	• END GATE ASSEMBLY (SEE FIG 17 FOR BREAKDOWN)	IPL-19
10	980456R	• END GATE ASSEMBLY (SEE FIG 17 FOR BREAKDOWN)	IPL-21
-1	980456L	• END GATE ASSEMBLY (SEE FIG 6 FOR NHA)	IPL-47
-2	980456R	• END GATE ASSEMBLY (SEE FIG 6 FOR NHA)	IPL-47
170	980456L	• END GATE LH	IPL-15
-1	5NONUMBER180	• END GATE REMOVAL, LH	IPL-19
-1	6NONUMBER140	• END GATE REMOVAL, RH	IPL-21
180	980456R	• END GATE RH	IPL-17
-1	TBD	• ENGINE COMPONENTS	IPL-111
40	980308	• ENGINE COVER, FRONT ACCESS	IPL-75
10	980307	• ENGINE COVER, REAR ACCESS	IPL-75
310	980620	• ENGINE, CUMMINS	IPL-113
100	980620	• ENGINE, CUMMINS 4 CYL TURBO	IPL-115
120	980713	• EXHAUST FAN HOUSING ASSEMBLY	IPL-81
130	980860	• EXHAUST STACK	IPL-76
-1	980233L	• EXTENSION ASSEMBLY LH (SEE FIG 8 FOR NHA)	IPL-51
-2	980233R	• EXTENSION ASSEMBLY RH (SEE FIG 9 FOR NHA)	IPL-51
250	980233L	• EXTENSION ASSEMBLY, LEFT-HAND	IPL-53
70	980233L	• EXTENSION ASSEMBLY, LH	IPL-23
70	980233R	• EXTENSION ASSEMBLY, RH	IPL-25
-260	980233R	• EXTENSION ASSEMBLY, RIGHT-HAND	IPL-53
-1	7NONUMBER140	• EXTENSION REMOVAL, LH	IPL-23
-1	8NONUMBER110	• EXTENSION REMOVAL, RH	IPL-25
150	984534R	• EXTENSION/AUGER CONTROLLER ENCLOSURE,	IPL-7
150	984534L	• EXTENSION/AUGER CONTROLLER ENCLOSURE, ELEC. 3 SWITCHES	IPL-11
140	983454	• FAN, RADIATOR	IPL-111
100	982941	• FILTER ELEMENT, HYDRAULIC	IPL-109
130	981917	• FILTER ELEMENT, HYDRAULIC CHARGE	IPL-109

INDEX BY PART DESCRIPTION CONT..

FIG ITEM	PART NUMBER.	NOMENCLATURE 123456	PAGE
90	982940	• FILTER HOUSING ASSEMBLY, HYDRAULIC	IPL-109
200	160160	• FILTER, FUEL PRIMARY	IPL-111
190	160170	• FILTER, FUEL SECONDARY	IPL-111
50	981520	• FILTER, INNER AIR	IPL-111
180	160180	• FILTER, OIL	IPL-111
60	981519	• FILTER, OUTER AIR	IPL-111
110	140610	• FITTING, GREASE, 1/4"-28	IPL-7
110	140610	• FITTING, GREASE, 1/4"-28	IPL-11
100	140610	• FITTING, GREASE, 1/4"-28	IPL-15
100	140610	• FITTING, GREASE, 1/4"-28	IPL-17
60	980047	• FLASHING, HOPPER CORNER	IPL-87
180	980047	• FLASHING, HOPPER CORNER	IPL-88
180	980047	• FLASHING, HOPPER CORNER	IPL-88
290	980046	• FLASHING, HOPPER FRONT	IPL-89
60	119-10	• FLAT WASHER, 1" SAE	IPL-15
150	119-10	• FLAT WASHER, 1" SAE	IPL-15
60	119-10	• FLAT WASHER, 1" SAE	IPL-17
150	119-10	• FLAT WASHER, 1" SAE	IPL-17
30	120-10	• FLAT WASHER, 1.0" SAE	IPL-45
126	119-5	• FLAT WASHER, 1/2" SAE	IPL-15
126	119-5	• FLAT WASHER, 1/2" SAE	IPL-17
40	119-5	• FLAT WASHER, 1/2" SAE	IPL-19
40	119-5	• FLAT WASHER, 1/2" SAE	IPL-21
30	119-5	• FLAT WASHER, 1/2" SAE	IPL-31
60	119-5	• FLAT WASHER, 1/2" SAE	IPL-31
30	119-5	• FLAT WASHER, 1/2" SAE	IPL-33
60	119-5	• FLAT WASHER, 1/2" SAE	IPL-33
210	119-5	• FLAT WASHER, 1/2" SAE	IPL-37
210	119-5	• FLAT WASHER, 1/2" SAE	IPL-41
70	119-5	• FLAT WASHER, 1/2" SAE	IPL-45
90	982038	• FLAT WASHER, 3/4" ID X 3" OD X 1/4"	IPL-15
90	982038	• FLAT WASHER, 3/4" ID X 3" OD X 1/4"	IPL-17
30	119-8	• FLAT WASHER, 3/4" SAE	IPL-23
60	119-8	• FLAT WASHER, 3/4" SAE	IPL-23
90	119-8	• FLAT WASHER, 3/4" SAE	IPL-23
30	119-8	• FLAT WASHER, 3/4" SAE	IPL-25
60	119-8	• FLAT WASHER, 3/4" SAE	IPL-25
90	119-8	• FLAT WASHER, 3/4" SAE	IPL-25
30	119-8	• FLAT WASHER, 3/4" SAE	IPL-27
60	119-8	• FLAT WASHER, 3/4" SAE	IPL-27
30	119-8	• FLAT WASHER, 3/4" SAE	IPL-35
30	119-8	• FLAT WASHER, 3/4" SAE	IPL-39
50	119-3	• FLAT WASHER, 3/8" SAE	IPL-7
170	119-3	• FLAT WASHER, 3/8" SAE	IPL-9
50	119-3	• FLAT WASHER, 3/8" SAE	IPL-11
170	119-3	• FLAT WASHER, 3/8" SAE	IPL-13
30	119-7	• FLAT WASHER, 5/8" SAE	IPL-15
80	119-7	• FLAT WASHER, 5/8" SAE	IPL-15
30	119-7	• FLAT WASHER, 5/8" SAE	IPL-17
80	119-7	• FLAT WASHER, 5/8" SAE	IPL-17
70	119-7	• FLAT WASHER, 5/8" SAE	IPL-35
70	119-7	• FLAT WASHER, 5/8" SAE	IPL-39
130	119-4	• FLAT WASHER, 7/16" SAE	IPL-27
220	119-4	• FLAT WASHER, 7/16" SAE	IPL-29
90	119-4	• FLAT WASHER, 7/16" SAE	IPL-7
90	119-4	• FLAT WASHER, 7/16" SAE	IPL-11
70	119-4	• FLAT WASHER, 7/16" SAE	IPL-19
70	119-4	• FLAT WASHER, 7/16" SAE	IPL-21
140	119-4	• FLAT WASHER, 7/16" SAE	IPL-31

ILLUSTRATED PARTS LIST



INDEX BY PART DESCRIPTION CONT..

FIG ITEM	PART NUMBER.	NOMENCLATURE 123456	PAGE
120	119-4	• FLAT WASHER, 7/16" SAE	IPL-35
170	119-4	• FLAT WASHER, 7/16" SAE	IPL-37
120	119-4	• FLAT WASHER, 7/16" SAE	IPL-39
170	119-4	• FLAT WASHER, 7/16" SAE	IPL-41
-1	2NONUMBER250	• FLIGHT SCREW ASSEMBLY, LH	IPL-11
-1	1NONUMBER100	• FLIGHT SCREW ASSEMBLY, RH	IPL-7
-1	TBD	• FLOOR BOARD ASSEMBLY	IPL-69
190	980292	• FLOORBOARD	IPL-70
250	980169	• FLOWGATE	IPL-82
150	11NONUMBER150	• FRAME ASSEMBLY	IPL-31
120	12NONUMBER120	• FRAME ASSEMBLY	IPL-33
230	13NONUMBER230	• FRAME ASSEMBLY	IPL-37
230	14NONUMBER230	• FRAME ASSEMBLY	IPL-41
200	1NONUMBER200	• FRAME ASSEMBLY	IPL-5
250	2NONUMBER250	• FRAME ASSEMBLY	IPL-9
250	3NONUMBER250	• FRAME ASSEMBLY	IPL-13
140	6NONUMBER140	• FRAME ASSEMBLY	IPL-19
140	7NONUMBER140	• FRAME ASSEMBLY	IPL-21
110	8NONUMBER110	• FRAME ASSEMBLY	IPL-23
110	9NONUMBER110	• FRAME ASSEMBLY	IPL-25
260	10NONUMBER260	• FRAME ASSEMBLY	IPL-29
380	980069	• FRONT AXLE HOUSING	IPL-93
180	17NONUMBER180	• GATE WELDMENT	IPL-47
90	851372	• GAUGE ROD, FLIGHT SCREW LEVEL	IPL-51
200	140410	• GAUGE, ENGINE OIL PRESSURE	IPL-105
270	140380	• GAUGE, FUEL LEVEL	IPL-105
30	230110	• GAUGE, PRESSURE	IPL-57
300	230110	• GAUGE, PRESSURE	IPL-59
90	230110	• GAUGE, PRESSURE, L.P.G.	IPL-5
170	230110	• GAUGE, PRESSURE, L.P.G.	IPL-5
180	140370	• GAUGE, TACHOMETER/HOURMETER	IPL-105
190	140390	• GAUGE, VOLTMETER	IPL-105
260	140400	• GAUGE, WATER TEMPERATURE	IPL-105
100	140610	• GREASE FITTING 1/4" - 28 SCREW	IPL-31
100	140610	• GREASE FITTING 1/4" - 28 SCREW	IPL-33
80	140610	• GREASE FITTING, 1/4"-28	IPL-51
140	140610	• GREASE FITTING, 1/4"-28	IPL-51
90	140610	• GREASE FITTING, 1/4"-28	IPL-47
130	140610	• GREASE FITTING, 1/4"-28	IPL-47
10	930055	• GUIDE WHEEL, TRUCK HITCH	IPL-117
130	930030	• GUIDE, WHEEL PIVOT ARM	IPL-117
330	980250	• HALF-SECTION, LEFT-HAND AUGER FLIGHT	IPL-67
-340	980240	• HALF-SECTION, RIGHT-HAND AUGER FLIGHT	IPL-67
110	870276	• HAND GRIP, FLIGHT/DEPTH SCREW	IPL-47
60	984406	• HAND RAIL ASSEMBLY, LH	IPL-43
10	984407	• HAND RAIL ASSEMBLY, RH	IPL-43
60	300060	• HANDLE, BOLT	IPL-121
80	300060	• HANDLE, BOLT	IPL-123
30	981453	• HANDLE, FLIGHT SCREW	IPL-7
30	981453	• HANDLE, FLIGHT SCREW	IPL-11
220	981487	• HANDLE, LOCK	IPL-9
220	981487	• HANDLE, LOCK	IPL-13
120	981918	• HEAD, HYDRAULIC CHARGE/RETURN FILTER	IPL-109
200	984576	• HINGE	IPL-53
90	980427	• HINGE PIN, WALKBOARD	IPL-27
180	980427	• HINGE PIN, WALKBOARD	IPL-29
310	856985	• HOLDDOWN, BATTERY	IP-83
260	980313	• HOOD	IPL-76
240	980707	• HOOD, EXHAUST MOTOR	IPL-82

INDEX BY PART DESCRIPTION CONT..

FIG ITEM	PART NUMBER.	NOMENCLATURE 123456	PAGE
-1	TBD	• HOODS AND COVERS	IPL-75
-1	TBD	• HOPPER WINGS	IPL-87
110	985108-48	• HOSE ASSEMBLY	IPL-57
380	985108-48	• HOSE ASSEMBLY	IPL-59
330	985108-20	• HOSE ASSEMBLY 20"	IPL-59
60	985108-22	• HOSE ASSEMBLY 22"	IPL-57
170	985108-24	• HOSE ASSEMBLY 24"	IPL-57
440	985108-24	• HOSE ASSEMBLY 24"	IPL-59
241	985108-43.5	• HOSE ASSEMBLY 43-1/2"	IPL-57
511	985108-43.5	• HOSE ASSEMBLY 43-1/2"	IPL-59
231	985108-52	• HOSE ASSEMBLY 52"	IPL-57
501	985108-52	• HOSE ASSEMBLY 52"	IPL-59
70	985108-53	• HOSE ASSEMBLY 53"	IPL-57
221	985108-54	• HOSE ASSEMBLY 54"	IPL-57
491	985108-54	• HOSE ASSEMBLY 54"	IPL-59
340	985108-55	• HOSE ASSEMBLY 55"	IPL-59
270	851243	• HOUSING, FRONT SLIDE BAR	IPL-124
230	851241	• HOUSING, REAR SLIDE BAR	IPL-124
10	851436	• HYDAULIC CYLINDER	IPL-87
40	851436	• HYDAULIC CYLINDER	IPL-87
130	851436	• HYDAULIC CYLINDER	IPL-87
160	851436	• HYDAULIC CYLINDER	IPL-88
10	980210	• HYDAULIC MOTOR, CONVEYOR DRIVE	IPL-85
-1	TBD	• HYDRAULIC COMPONENTS	IPL-109
10	131090	• HYDRAULIC CYLINDER, 685 FRONT BLADE LIFT	IPL-65
140	981050	• HYDRAULIC CYLINDER, SCREED EXTENSION LH	IPL-35
140	980430	• HYDRAULIC CYLINDER, SCREED EXTENSION RH	IPL-39
120	980980	• HYDRAULIC CYLINDER, SCREED LIFT 8816	IPL-15
120	980980	• HYDRAULIC CYLINDER, SCREED LIFT 8816	IPL-17
100	980420	• HYDRAULIC CYLINDER, SCREED SLOPE	IPL-35
100	980420	• HYDRAULIC CYLINDER, SCREED SLOPE	IPL-39
220	980150	• HYDRAULIC CYLINDER, TRACK TENSION	IPL-102
120	980230	• HYDRAULIC MOTOR, 8816 AUGER DRIVE	IPL-65
380	980120	• HYDRAULIC MOTOR, PROPULSION	IPL-103
10	983405	• HYDRAULIC MOTOR, SCREED VIBRATOR.	IPL-55
-1	TBD	• HYDRAULIC PUMPS	IPL-115
170	980174	• HYDRAULIC TANK	IPL-109
140	900120	• INDICATOR LIGHT (RED), HIGH	IPL-105
380	900120	• INDICATOR LIGHT (RED), HIGH	IPL-107
-101	981937	• INLINE FUEL FILTER	IPL-111
60	280040	• INSERT, 3-JAW COUPLING	IPL-55
170	981523	• INTERMEDIATE PIPE, AIR BREATHER	IPL-76
100	852090	• JUNCTION BOX, ELECTRONIC, STEERING	IPL-127
250	36145-01	• KEY, IGNITION (FOR SWITCH 36145 ONLY)	IPL-105
190	981451	• KIT, LOWER FLIGHT SCREW ASSEMBLY	IPL-13
190	984559	• KIT, LOWER FLIGHT SCREW ASSEMBLY	IPL-9
10	981574	• KNOB, REVOLVING BALL	IPL-7
10	981574	• KNOB, REVOLVING BALL	IPL-11
110	853941	• L.P.G. BOTTLE HOLDER ASSEMBLY	IPL-5
190	853941	• L.P.G. BOTTLE HOLDER ASSEMBLY	IPL-5
183	980700	• LINK, CHAIN	IPL-92
185	980690-01	• LINK, DRAG BAR	IPL-92
230	982157	• LINKAGE, THROTTLE	IPL-113
270	982157	• LINKAGE, THROTTLE	IPL-113
50	980440-03	• LOAD CHECK VALVE	IPL-109
-351	143-5	• LOCK NUT, 1/2" - 13 HEX	IPL-67
30	118-7	• LOCK WASHER, 5/8" SAE	IPL-55
30	118-2	• LOCKWASHER, 5/16"	IPL-61
120	170100A	• LOWER RADIATOR HOSE	IPL-111

ILLUSTRATED PARTS LIST



INDEX BY PART DESCRIPTION CONT..

FIG ITEM	PART NUMBER.	NOMENCLATURE 123456	PAGE
1		• LPG TANKS AND STAIRWAY REMOVAL	IPL-5
-1	980640	• MAIN HARNESS WIRING	IPL-127
10	980440	• MANIFOLD ASSEMBLY, MAIN VALVE BANK	IPL-109
-1	980501	• MFG, SCREED 8816	IPL-5
80	851547	• MICRO CONTROLLER, ELECTRONIC	IPL-127
90	851547	• MICRO CONTROLLER, ELECTRONIC	IPL-127
60	980530	• MICRO CONTROLLER, RH	IPL-127
150	980590	• MOTOR, HYDRAULIC	IPL-82
10	984287	• MOUNT ASSEMBLY, SONIC AUGER, LH	IPL-47
-11	984288	• MOUNT ASSEMBLY, SONIC AUGER, RH	IPL-47
70	851575	• MOUNT, PIVOT	IPL-121
90	851575	• MOUNT, PIVOT	IPL-123
240	980382	• MOUNT, SIGHT GAUGE	IPL-76
180	853345	• MOUNTING BLOCK	IPL-97
90	981704	• MOUNTING BRACKET	IPL-111
70	981705	• MOUNTING BRACKET	IPL-111
121	320140-1	• MOUNTING PAD	IPL-85
220	851483	• MOUNTING PLATE, CONVEYOR	IPL-92
180	980705	• MOUNTING PLATE, HYDRAULIC MOTOR	IPL-82
160	980127	• MOUNTING PLATE, MOTOR	IPL-66
130	980085	• MOUNTING PLATE, WELDMENT	IPL-85
90	984441	• MUFFLER	IPL-75
160	116-10	• NUT, 1" - 8 HEX LOCK	IPL-15
160	116-10	• NUT, 1" - 8 HEX LOCK	IPL-17
50	115-10-1	• NUT, 1" - HEX JAM	IPL-15
50	115-10-1	• NUT, 1" - HEX JAM	IPL-17
30	116-5	• NUT, 1/2" - 13 HEX	IPL-5
60	116-5	• NUT, 1/2" - 13 HEX	IPL-5
140	116-5	• NUT, 1/2" - 13 HEX	IPL-5
50	116-5	• NUT, 1/2" - 13 HEX	IPL-19
50	116-5	• NUT, 1/2" - 13 HEX	IPL-21
220	116-5	• NUT, 1/2" - 13 HEX	IPL-37
220	116-5	• NUT, 1/2" - 13 HEX	IPL-41
270	116-5	• NUT, 1/2" HEX	IPL-88
190	143-5	• NUT, 1/2" HEX LOCK	IPL-124
140	116-8	• NUT, 3/4" - 10 HEX	IPL-65
260	117-8	• NUT, 3/4", HEX HEAVY	IP-83
270	116-8-1	• NUT, 3/4", HEX, JAM	IP-83
20	116-3	• NUT, 3/8" - 16 HEX	IPL-7
60	116-3	• NUT, 3/8" - 16 HEX	IPL-7
180	116-3	• NUT, 3/8" - 16 HEX	IPL-9
240	116-3	• NUT, 3/8" - 16 HEX	IPL-9
20	116-3	• NUT, 3/8" - 16 HEX	IPL-11
60	116-3	• NUT, 3/8" - 16 HEX	IPL-11
180	116-3	• NUT, 3/8" - 16 HEX	IPL-13
240	116-3	• NUT, 3/8" - 16 HEX	IPL-13
30	116-3	• NUT, 3/8" - 16 HEX	IPL-43
80	116-3	• NUT, 3/8" - 16 HEX	IPL-43
70	920070	• NUT, 3/8" - 16 WING	IPL-5
150	920070	• NUT, 3/8" - 16 WING	IPL-5
20	116-2	• NUT, 5/16" - 18 HEX	IPL-61
40	116-7	• NUT, 5/8" - 11 HEX	IPL-15
40	116-7	• NUT, 5/8" - 11 HEX	IPL-17
90	115-7	• NUT, 5/8" HEX	IPL-117
90	116-7	• NUT, 5/8" HEX	IPL-87
370	116-7	• NUT, 5/8" HEX	IPL-93
400	116-7	• NUT, 5/8" HEX	IPL-93
140	116-7	• NUT, 5/8" HEX	IPL-95
340	116-7	• NUT, 5/8" HEX	IPL-103

INDEX BY PART DESCRIPTION CONT..

FIG ITEM	PART NUMBER.	NOMENCLATURE 123456	PAGE
210	119-7	• NUT, 5/8" HEX	IPL-88
140	116-4	• NUT, 7/16" - 14 HEX	IPL-27
230	116-4	• NUT, 7/16" - 14 HEX	IPL-29
100	116-4	• NUT, 7/16" - 14 HEX	IPL-7
100	116-4	• NUT, 7/16" - 14 HEX	IPL-11
80	116-4	• NUT, 7/16" - 14 HEX	IPL-19
110	116-4	• NUT, 7/16" - 14 HEX	IPL-19
80	116-4	• NUT, 7/16" - 14 HEX	IPL-21
110	116-4	• NUT, 7/16" - 14 HEX	IPL-21
180	116-4	• NUT, 7/16" - 14 HEX	IPL-37
180	116-4	• NUT, 7/16" - 14 HEX	IPL-41
50	116-4	• NUT, 7/16" - 14 HEX	IPL-43
100	116-4	• NUT, 7/16" - 14 HEX	IPL-43
130	116-4	• NUT, 7/16" - 14 HEX	IPL-43
132	116-4	• NUT, 7/16" - 14 HEX	IPL-43
20	116-9	• NUT, 7/8" - 9 HEX	IPL-19
20	116-9	• NUT, 7/8" - 9 HEX	IPL-21
100	115-3	• NUT, HEX, 3/8"-24	IPL-51
20	116-10-1	• NUT, JAM, 1"-8	IPL-51
130	143-5	• NUT, LOCK, 1/2"-13	IPL-51
190	143-5	• NUT, LOCK, 1/2"-13	IPL-53
220	143-5	• NUT, LOCK, 1/2"-13	IPL-53
180	143-3	• NUT, LOCK, 3/8"-16	IPL-53
70	143-4	• NUT, SELF-LOCKING, 7/16"-14	IPL-51
-1	TBD	• OPERATOR'S PLATFORM	IPL-61
90	984991	• O-RING	IPL-115
60	984992	• O-RING	IPL-115
30	984993	• O-RING	IPL-115
110	984994	• O-RING	IPL-65
-1	TBD	• PAVER GRADE CONTROLS SPECTRA PHYSICS	IPL-121
-1	TBD	• PAVER LEVELING CONTROL	IPL-123
100	984575	• PIN ASSEMBLY, SCREED EXTENSION	IPL-23
100	984575	• PIN ASSEMBLY, SCREED EXTENSION	IPL-25
210	210060	• PIN, CLEVIS	IPL-119
200	240030	• PIN, CLEVIS	IPL-9
200	240030	• PIN, CLEVIS	IPL-13
82	240030	• PIN, CLEVIS	IPL-45
440	240030	• PIN, CLEVIS	IPL-67
230	240030	• PIN, CLEVIS	IPL-102
84	81019	• PIN, COTTER	IPL-45
22	81019	• PIN, COTTER	IPL-65
32	81019	• PIN, COTTER	IPL-65
450	81019	• PIN, COTTER	IPL-67
52	81019	• PIN, COTTER	IPL-87
172	81019	• PIN, COTTER	IPL-88
232	81019	• PIN, COTTER	IPL-102
200	930039	• PIN, COTTER	IPL-119
260	930039	• PIN, COTTER	IPL-124
300	930039	• PIN, COTTER	IPL-125
181	980730	• PIN, COTTER	IPL-92
210	81019	• PIN, COTTER, 0.156" X 2.50"	IPL-9
210	81019	• PIN, COTTER, 0.156" X 2.50"	IPL-13
30	858693	• PIN, CYLINDER	IPL-65
50	980166	• PIN, CYLINDER	IPL-87
170	980166	• PIN, CYLINDER	IPL-88
20	980737	• PIN, CYLINDER	IPL-65
182	980720	• PIN, LINK	IPL-92
150	230950	• PIPE NIPPLE, 1/4 X 2	IPL-57
420	230950	• PIPE NIPPLE, 1/4 X 2	IPL-59

ILLUSTRATED PARTS LIST



INDEX BY PART DESCRIPTION CONT..

FIG ITEM	PART NUMBER.	NOMENCLATURE 123456	PAGE
210	99609	• PIPE, NIPPLE 1/4" X 4	IPL-57
480	99609	• PIPE, NIPPLE 1/4" X 4	IPL-59
110	980033	• PIPE, PUSHBAR ROLLER	IPL-95
10	980036	• PIPE, PUSHBAR ROLLER	IPL-95
320	980115	• PIVOT, CUTOFF	IPL-67
120	980209	• PLATE ASSEMBLY, MAIN WEAR, 8816	IPL-31
130	980288L	• PLATE, FLOORBOARD, LH	IPL-70
100	980288R	• PLATE, FLOORBOARD, RH	IPL-69
350	982183	• PLATE, FRONT AXLE HOUSING	IPL-93
360	980086	• PLATE, HOPPER BACK	IP-83
160	980736	• PLATE, HYDRAULIC ACCESS	IPL-70
250	980286	• PLATE, HYDRAULIC OUTPUT	IPL-71
350	980281L	• PLATE, LH SIDE	IPL-77
550	982268L	• PLATE, LH SIDE	IPL-79
220	980101	• PLATE, REAR COVER	IPL-70
450	980281R	• PLATE, RH SIDE	IPL-79
510	982268R	• PLATE, RH SIDE	IPL-79
110	980243	• PLATE, SIDE MOUNT	IPL-31
110	980243	• PLATE, SIDE MOUNT	IPL-33
100	980332	• PLATE, SIDEWING RUBBER SHEILD	IPL-87
220	980332	• PLATE, SIDEWING RUBBER SHEILD	IPL-88
110	856742	• PLATE, STOP	IPL-27
200	856742	• PLATE, STOP	IPL-29
50	855568	• PLATE, TAPPED	IPL-45
120	980429	• PLATE, TOOL BOX TRAY	IPL-19
120	980429	• PLATE, TOOL BOX TRAY	IPL-21
20	230030	• POL ADAPTER, LPG TANK	IPL-57
290	230030	• POL ADAPTER, LPG TANK	IPL-59
158	980640-01	• POTENTIOMETER	IPL-7
158	980640-1	• POTENTIOMETER	IPL-11
10	981420L	• PULL ARM, LH	IP-101
11	981420R	• PULL ARM, RH	IP-101
210	P86879B	• PUMP DRIVE PLATE, FLYWHEEL	IPL-111
70	980400	• PUMP, DOUBLE DRIVE	IPL-115
80	980510	• PUMP, FAN DRIVE	IPL-115
10	980490	• PUMP, PRESSURE COMP.	IPL-115
40	980470	• PUMP, VARIABLE AUGER/CONVEYOR	IPL-115
50	980470	• PUMP, VARIABLE AUGER/CONVEYOR	IPL-115
20	980500	• PUMP, VARIABLE CHARGE	IPL-115
-1	TBD	• PUSHBAR	IPL-95
200	980270	• QUARTER SECTION, LEFT-HAND AUGER FLIGHT	IPL-66
-210	980260	• QUARTER SECTION, RIGHT-HAND AUGER FLIGHT	IPL-66
190	851183	• QUICK DISCONNECT, 1/4" MALE	IPL-57
460	851183	• QUICK DISCONNECT, 1/4" MALE	IPL-59
130	980280	• RADIATOR ASSEMBLY	IPL-111
-1	TBD	• REAR AUGER ASSEMBLY	IPL-65
280	980066	• REAR AXLE HOUSING	IPL-92
280	3NONUMBER280	• REAR PLATE, WELDMENT	IPL-71
100	982515	• REGULATOR, L.P.G.,	IPL-5
180	982515	• REGULATOR, L.P.G.,	IPL-5
40	982515	• REGULATOR, PRESSURE	IPL-57
310	982515	• REGULATOR, PRESSURE	IPL-59
-281	140470	• RELAY, ENGINE SHUTDOWN	IPL-105
100	980157	• RETAINER, HYDRAULIC CYLINDER	IPL-85
10	980228	• ROD, EXTENSION	IPL-23
40	980228	• ROD, EXTENSION	IPL-23
10	980228	• ROD, EXTENSION	IPL-25
40	980228	• ROD, EXTENSION	IPL-25
100	930040	• ROLLER	IPL-117

INDEX BY PART DESCRIPTION CONT..

FIG ITEM	PART NUMBER.	NOMENCLATURE 123456	PAGE
10	980393L	• SCREED ARM	IPL-15
10	980393R	• SCREED ARM (REFER TO FIGURE 16 FOR BREAKDOWN)	IPL-17
-1	980341	• SCREED ARM ASSEMBLY (SEE FIG 5 FOR NHA)	IPL-45
-1	3NONUMBER250	• SCREED ARM REMOVAL, LH	IPL-15
-1	4NONUMBER170	• SCREED ARM REMOVAL, RH	IPL-17
100	980393L	• SCREED ARM WELDMENT, LH	IPL-45
-110	980393R	• SCREED ARM WELDMENT, RH	IPL-45
120	983515	• SCREW ASSEMBLY, DEPTH	IPL-47
110	102-908-1A	• SCREW, 1.0" - 8 X 1.75 HEX CAP	IPL-85
20	100-909-1A	• SCREW, 1.0" - 8 X 2.0 HEX CAP, FINE THREAD	IP-101
200	102-407-1A	• SCREW, 1/2" - 13 X 1.5 HEX CAP	IPL-70
-191	108-404-1A	• SCREW, 1/2" - 13 X 1", SET	IPL-66
270	102-405-1A	• SCREW, 1/2" - 13 X 1.0 HEX CAP	IPL-76
100	102-409-1A	• SCREW, 1/2" - 13 X 1.0 HEX CAP	IPL-61
80	102-406-1A	• SCREW, 1/2" - 13 X 1.25 HEX CAP	IPL-111
310	110-406-1A	• SCREW, 1/2" - 13 X 1.25 SOCKET HEAD CAP	IPL-67
460	102-407-1A	• SCREW, 1/2" - 13 X 1.5 HEX CAP	IPL-79
300	104-407-1A	• SCREW, 1/2" - 13 X 1.5 HEX CAP	IPL-113
170	102-408-1A	• SCREW, 1/2" - 13 X 1.75 HEX CAP	IPL-63
140	102-408-1A	• SCREW, 1/2" - 13 X 1.75 HEX CAP	IPL-92
160	102-408-1A	• SCREW, 1/2" - 13 X 1.75 HEX CAP	IPL-92
200	102-408-1A	• SCREW, 1/2" - 13 X 1.75 HEX CAP	IPL-92
50	102-409-1A	• SCREW, 1/2" - 13 X 2.0 HEX CAP	IPL-65
80	102-409-1A	• SCREW, 1/2" - 13 X 2.0 HEX CAP	IPL-65
170	102-409-1A	• SCREW, 1/2" - 13 X 2.0 HEX CAP	IPL-66
250	102-409-1A	• SCREW, 1/2" - 13 X 2.0 HEX CAP	IPL-66
140	102-409-1A	• SCREW, 1/2" - 13 X 2.0 HEX CAP	IPL-76
20	851111	• SCREW, 1/2" - 13 X 2.0 HEX CAP, FLAT HEAD	IPL-117
260	102-410-1A	• SCREW, 1/2" - 13 X 2.25 HEX CAP	IPL-88
20	102-410-1A	• SCREW, 1/2" - 13 X 2.25 HEX CAP	IPL-91
50	102-410-1A	• SCREW, 1/2" - 13 X 2.25 HEX CAP	IPL-91
80	102-410-1A	• SCREW, 1/2" - 13 X 2.25 HEX CAP	IPL-91
110	102-410-1A	• SCREW, 1/2" - 13 X 2.25 HEX CAP	IPL-91
20	102-410-1A	• SCREW, 1/2" - 13 X 2.25 HEX CAP	IPL-95
70	102-410-1A	• SCREW, 1/2" - 13 X 2.25 HEX CAP	IPL-95
170	102-411-1A	• SCREW, 1/2" - 13 X 2.5 HEX CAP	IPL-124
20	100-406-1A	• SCREW, 1/2" - 13 X 1.25 HEX CAP	IPL-85
100	104-407-1A	• SCREW, 1/2" - 13 X 1.5 FLAT HEAD	IPL-111
190	102-5-1A	• SCREW, 1/4" - 20 X 0.5 HEX CAP	IPL-82
130	102-711-1A	• SCREW, 3/4" - 10 X 2.5 HEX CAP	IPL-65
330	102-709-1A	• SCREW, 3/4" - 15 - 2.0 HEX	IPL-125
170	102-203-1A	• SCREW, 3/8" - 16 X 0.5 HEX CAP	IPL-119
420	102-205-1A	• SCREW, 3/8" - 16 X 1.0 HEX CAP	IPL-67
490	102-205-1A	• SCREW, 3/8" - 16 X 1.0 HEX CAP	IPL-79
530	102-205-1A	• SCREW, 3/8" - 16 X 1.0 HEX CAP	IPL-79
90	102-205-1A	• SCREW, 3/8" - 16 X 1.0 HEX CAP	IPL-81
20	102-206-1A	• SCREW, 3/8" - 16 X 1.25 HEX CAP	IPL-69
230	100-206-1A	• SCREW, 3/8" - 16 X 1.25 HEX CAP, FINE THREAD	IPL-70
260	100-206-1A	• SCREW, 3/8" - 16 X 1.25 HEX CAP, FINE THREAD	IPL-71
290	100-206-1A	• SCREW, 3/8" - 16 X 1.25 HEX CAP, FINE THREAD	IP-83
340	100-206-1A	• SCREW, 3/8" - 16 X 1.25 HEX CAP, FINE THREAD	IP-83
160	102-207-1A	• SCREW, 3/8" - 16 X 1.5 HEX CAP	IPL-82
150	102-209-1A	• SCREW, 3/8" - 16 X 2.0 HEX CAP	IPL-63
200	102-209-1A	• SCREW, 3/8" - 16 X 2.0 HEX CAP	IPL-63
110	102-209-1A	• SCREW, 3/8" - 16 X 2.0 HEX CAP	IPL-75
30	100-206-1A	• SCREW, 3/8" - 16 X 1.25 HEX CAP, FINE THREAD	IPL-81
60	100-206-1A	• SCREW, 3/8" - 16 X 1.25 HEX CAP, FINE THREAD	IPL-81
100	100-206-1A	• SCREW, 3/8" - 16 X 1.25 HEX CAP, FINE THREAD	IPL-81
50	102-105-1A	• SCREW, 5/16" - 16 X 1.0 HEX CAP	IPL-69

ILLUSTRATED PARTS LIST



INDEX BY PART DESCRIPTION CONT..

FIG ITEM	PART NUMBER.	NOMENCLATURE 123456	PAGE
20	102-105-1A	• SCREW, 5/16" - 16 X 1.0 HEX CAP	IPL-75
50	102-105-1A	• SCREW, 5/16" - 16 X 1.0 HEX CAP	IPL-75
300	102-105-1A	• SCREW, 5/16" - 16 X 1.0 HEX CAP	IPL-76
330	102-105-1A	• SCREW, 5/16" - 16 X 1.0 HEX CAP	IPL-77
390	102-105-1A	• SCREW, 5/16" - 16 X 1.0 HEX CAP	IPL-77
50	102-105-1A	• SCREW, 5/16" - 18 X 1.0 HEX CAP	IPL-61
80	102-105-1A	• SCREW, 5/16" - 18 X 1.0 HEX CAP	IPL-69
110	102-105-1A	• SCREW, 5/16" - 18 X 1.0 HEX CAP	IPL-69
140	102-105-1A	• SCREW, 5/16" - 18 X 1.0 HEX CAP	IPL-70
170	102-105-1A	• SCREW, 5/16" - 18 X 1.0 HEX CAP	IPL-70
80	102-606-1A	• SCREW, 5/8" - 11 X 1.0 HEX CAP	IPL-121
100	102-606-1A	• SCREW, 5/8" - 11 X 1.0 HEX CAP	IPL-123
360	102-608-1A	• SCREW, 5/8" - 11 X 1.75 HEX CAP	IPL-93
290	102-609-1A	• SCREW, 5/8" - 11 X 2.0 HEX CAP	IPL-71
190	102-609-1A	• SCREW, 5/8" - 11 X 2.0 HEX CAP	IPL-88
120	100-611-1A	• SCREW, 5/8" - 11 X 2.5 HEX CAP, FINE THREAD	IP-101
200	100-611-1A	• SCREW, 5/8" - 11 X 2.5 HEX CAP, FINE THREAD	IPL-102
250	100-614-1A	• SCREW, 5/8" - 11 X 3.25 HEX CAP, FINE THREAD	IPL-102
60	102-615-1A	• SCREW, 5/8" - 11 X 3.5 HEX CAP	IPL-117
30	102-617-1A	• SCREW, 5/8" - 11 X 4.0 HEX CAP	IPL-123
390	983592	• SCREW, 5/8" - 11 X THREADED ROD	IPL-93
130	102-608-1A	• SCREW, 5/8" - 13 X 1.75 HEX CAP	IPL-95
70	100-613-1A	• SCREW, 5/8" - 13 X 3.0 HEX CAP	IP-101
150	100-613-1A	• SCREW, 5/8" - 13 X 3.0 HEX CAP	IPL-102
290	100-613-1A	• SCREW, 5/8" - 13 X 3.0 HEX CAP	IPL-103
320	100-613-1A	• SCREW, 5/8" - 13 X 3.0 HEX CAP	IPL-103
160	102-613-1A	• SCREW, 5/8" - 13 X 3.0 HEX CAP	IPL-97
70	108-606-1A	• SCREW, 5/8" - 16 X 1.25 SET	IPL-85
70	102-609-1A	• SCREW, 5/8" - 11 X 2.0 HEX CAP	IPL-87
290	102-608-1A	• SCREW, 5/8" - 13 X 1.75 HEX CAP	IPL-92
120	102-305-1A	• SCREW, 7/16" - 14 X 1.0 HEX CAP	IPL-63
290	102-305-1A	• SCREW, 7/16" - 14 X 1.0 HEX CAP	IPL-66
130	102-306-1A	• SCREW, 7/16" - 14 X 1.25 HEX CAP	IPL-82
440	920070	• SCREW, 7/16" - 14 X 1.25 HEX CAP, THUMB	IPL-77
210	920070	• SCREW, 7/16" - 14 X 1.25 HEX CAP, WING	IPL-76
230	920070	• SCREW, 7/16" - 14 X 1.25 HEX CAP, WING	IPL-76
250	920070	• SCREW, 7/16" - 14 X 1.25 HEX CAP, WING	IPL-76
20	102-807-1A	• SCREW, 7/8" - 9 X 1.5 HEX CAP	IPL-87
140	102-807-1A	• SCREW, 7/8" - 9 X 1.5 HEX CAP	IPL-88
220	110-507-1A	• SCREW, 9/16" - 12 X 1.5 SOCKET HEAD CAP	IPL-66
160	102-405-1A	• SCREW, HEX CAP, 1/2"-13 X 1"	IPL-47
210	102-409-1A	• SCREW, HEX HEAD CAP, 1/2"-13 X 2	IPL-53
120	102-412-1A	• SCREW, HEX HEAD CAP, 1/2"-13 X 2-3/4"	IPL-51
60	102-310-1A	• SCREW, HEX HEAD CAP, 7/16"-14 X 2-1/4"	IPL-51
60	102-305-1A	• SCREW, HEX, 7-16-14 X 1"	IPL-47
360	100-M16 X 55-1A	• SCREW, M16 X 55 HEX CAP	IPL-103
390	100-M16 X 55-1A	• SCREW, M16 X 55 HEX CAP	IPL-103
192	851481	• SEAL KIT	IPL-119
-86	851484	• SEAL KIT	IPL-45
-11	851484	• SEAL KIT	IPL-87
-41	851484	• SEAL KIT	IPL-87
-131	851484	• SEAL KIT	IPL-87
-161	851484	• SEAL KIT	IPL-88
-432	870312	• SEAL KIT	IPL-67
-11	130050-1	• SEAL KIT	IPL-65
-222	980150-01	• SEAL KIT	IPL-102
-102	980420-01	• SEAL KIT	IPL-39
-97	980520-02	• SEAL KIT	IPL-65
-122	980980-01	• SEAL KIT	IPL-15

INDEX BY PART DESCRIPTION CONT..

FIG ITEM	PART NUMBER.	NOMENCLATURE 123456	PAGE
-122	980980-01	• SEAL KIT	IPL-17
-102	981050-01	• SEAL KIT	IPL-35
-142	981050-01	• SEAL KIT	IPL-35
-142	981050-01	• SEAL KIT	IPL-39
10	360010	• SEAT ASSEMBLY, OPERATOR'S	IPL-61
230	980148	• SHAFT CAP, AUGER	IPL-66
360	980121	• SHAFT, AUGER	IPL-67
125	980256	• SHAFT, CYLINDER MOUNT	IPL-35
60	980034	• SHAFT, PUSHBAR ROLLER	IPL-95
100	980457	• SHAFT, TILT SCREW SWIVEL	IPL-47
40	982125	• SHIM	IP-101
-72	982583	• SHIM, FLIGHT SCREW	IPL-7
-72	982583	• SHIM, FLIGHT SCREW	IPL-11
150	851425	• SHOCK MOUNT, SLOPE	IPL-121
170	870279	• SHOULDER SCREW, SOCKET HEAD CAP, 3/8"-16	IPL-53
130	230070	• SHUTOFF VALVE, BRASS	IPL-57
260	230070	• SHUTOFF VALVE, BRASS	IPL-57
400	230070	• SHUTOFF VALVE, BRASS	IPL-59
530	230070	• SHUTOFF VALVE, BRASS	IPL-59
230	980037L	• SIDEWING, HOPPER LH	IPL-88
110	980037R	• SIDEWING, HOPPER RH	IPL-87
190	980373	• SIGHT GAUGE ASSEMBLY	IPL-76
160	851249	• SKID	IPL-123
70	980225	• SLIDE ASSEMBLY, EXTENSION	IPL-31
70	980225	• SLIDE ASSEMBLY, EXTENSION	IPL-33
-1	11NONUMBER150	• SLIDE ASSEMBLY, LH	IPL-33
-1	10NONUMBER260	• SLIDE ASSEMBLY, RH	IPL-31
80	980109	• SLIDE, CONVEYOR ADJUSTMENT	IPL-85
120	851421	• SLOPE METER	IPL-123
140	851430	• SLOPE MODULE, SCREED	IPL-121
90	980380	• SNAP RING	IPL-31
90	980380	• SNAP RING	IPL-33
170	160310	• SOLENOID ASSEMBLY	IPL-111
44	980550	• SONIC AUGER CORD	IPL-47
42	980540	• SONIC AUGER SENSOR	IPL-47
20	851422	• SONIC TRACER	IPL-121
20	851579	• SONIC TRACER	IPL-123
30	851186	• SPACER	IPL-51
10	851629	• SPECTRA CONTROL WIRING	IPL-127
130	851629	• SPECTRA CONTROL WIRING	IPL-127
-21	900010	• SPRAYDOWN PUMP	IPL-81
220	851245	• SPRING, TENSION	IPL-124
370	980131	• SPROCKET ASSEMBLY, AUGER	IPL-67
190	980188	• SPROCKET ASSEMBLY, AUGER DRIVE	IPL-66
50	980165	• SPROCKET, CONVEYOR DRIVE	IPL-85
210	980062	• SPROCKET, CONVEYOR, REAR	IPL-92
300	980298	• SPROCKET, FRONT AXLE HOUSING	IPL-93
330	980298	• SPROCKET, FRONT AXLE HOUSING	IPL-93
230	980153	• SPROCKET, REAR AXLE HOUSING	IPL-92
260	980295	• SPROCKET, REAR AXLE HOUSING	IPL-92
310	980140	• SPROCKET, TRACK	IPL-103
-1	980444	• STAIRWAY ASSEMBLY (SEE FIG 1 FOR NHA)	IPL-43
40	981913	• STEERING BOX, SUNDSTRAND WHEEL	IPL-61
70	980274	• STEERING MOUNT ASSEMBLY, ELECTRONIC	IPL-61
140	984408	• STEP ASSEMBLY, LH SIDE	IPL-43
150	984409	• STEP ASSEMBLY, RH SIDE	IPL-43
10	980439	• STOP BAR, SCREED ARM	IPL-45
410	984393	• STOP BRACKET, AUGER CUTOFF	IPL-67
40	980441	• STOP TUBE, ARM INNER ROLLER	IPL-45

ILLUSTRATED PARTS LIST



INDEX BY PART DESCRIPTION CONT..

FIG ITEM	PART NUMBER.	NOMENCLATURE 123456	PAGE
150	980560	• STRAINER, HYDRAULIC SUCTION	IPL-109
140	980630	• STRAINER, HYDRAULIC SUCTION	IPL-109
-101	211748-02	• STROBE LIGHT, AMBER	IPL-75
140	980104	• SUPPORT ASSEMBLY, CONTROL DECK	IPL-63
310	851248	• SUPPORT, ARM SKID (FRONT)	IPL-125
320	851247	• SUPPORT, ARM SKID (REAR)	IPL-125
240	980112	• SUPPORT, AUGER	IPL-66
-291	980620-02	• SWITCH, FUEL SHUTOFF	IPL-113
240	36145	• SWITCH, IGNITION, 3 POS, 10 AMP	IPL-105
370	900122	• SWITCH, PUSH BUTTON - HORN	IPL-107
154	851393	• SWITCH, TOGGLE	IPL-7
152	900030	• SWITCH, TOGGLE	IPL-7
156	900030	• SWITCH, TOGGLE	IPL-7
152	900030	• SWITCH, TOGGLE	IPL-11
154	900030	• SWITCH, TOGGLE	IPL-11
156	900030	• SWITCH, TOGGLE	IPL-11
50	900030	• SWITCH, TOGGLE - AUTO CONVEYOR	IPL-105
460	900030	• SWITCH, TOGGLE - LEFT CONVEYOR AND AUGER	IPL-107
110	851392	• SWITCH, TOGGLE - LEFT CUTOFF	IPL-105
450	851392	• SWITCH, TOGGLE - LEFT CUTOFF	IPL-107
150	851392	• SWITCH, TOGGLE - LEFT EXTENSION	IPL-105
440	851392	• SWITCH, TOGGLE - LEFT EXTENSION	IPL-107
60	900030	• SWITCH, TOGGLE - MANUAL LEFT CONVEYOR	IPL-105
70	900030	• SWITCH, TOGGLE - MANUAL RIGHT CONVEYOR	IPL-105
470	900030	• SWITCH, TOGGLE - RIGHT CONVEYOR AND AUGER	IPL-107
90	851392	• SWITCH, TOGGLE - RIGHT CUTOFF	IPL-105
420	851392	• SWITCH, TOGGLE - RIGHT CUTOFF	IPL-107
80	851392	• SWITCH, TOGGLE - RIGHT EXTENSION	IPL-105
40	900080	• SWITCH, TOGGLE - RIGHT SCREW	IPL-105
430	900030	• SWITCH, TOGGLE - SCREED LIFT	IPL-107
130	851392	• SWITCH, TOGGLE - SIDEWINGS	IPL-105
410	851392	• SWITCH, TOGGLE - SIDEWINGS	IPL-107
170	900080	• SWITCH, TOGGLE - THROTTLE	IPL-105
10	851392	• SWITCH, TOGGLE - TRUCK HITCH	IPL-105
350	851392	• SWITCH, TOGGLE - TRUCK HITCH	IPL-107
100	900030	• SWITCH, TOGGLE - SCREED LIFT	IPL-105
360	900080	• SWITCH, TOGGLE, - THROTTLE	IPL-107
160	851394	• SWITCH, TOGGLE, 8500 ELITE III	IPL-105
310	851390	• SWITCH, TOGGLE, AUTO CONVEYOR	IPL-107
320	900080	• SWITCH, TOGGLE, LEFT SCREW	IPL-107
390	851392	• SWITCH, TOGGLE, RIGHT EXTENSION	IPL-107
120	851391	• SWITCH, TOGGLE, SPST. 2 POS - 2 SPEED	IPL-105
400	851391	• SWITCH, TOGGLE, SPST. 2 POS - 2 SPEED	IPL-107
290	851391	• SWITCH, TOGGLE, SPST. 2 POS - BEACON	IPL-107
20	851391	• SWITCH, TOGGLE, SPST. 2 POS - GRADE CONTROL	IPL-105
340	851391	• SWITCH, TOGGLE, SPST. 2 POS - GRADE CONTROL	IPL-107
280	851391	• SWITCH, TOGGLE, SPST. 2 POS - SPRAYDOWN	IPL-105
30	851391	• SWITCH, TOGGLE, SPST. 2 POS - VIBRATOR	IPL-105
330	851391	• SWITCH, TOGGLE, SPST. 2 POS - VIBRATOR	IPL-107
300	851391	• SWITCH, TOGGLE, SPST. 2 POS - WORKLIGHTS	IPL-107
80	230010	• TANK, L.P.G., 20 LBS	IPL-5
160	230010	• TANK, L.P.G., 20 LBS	IPL-5
10	230010	• TANK, L.P.G., 20 LBS. (INCLUDES SHUTOFF VALVE)	IPL-57
280	230010	• TANK, L.P.G., 20 LBS. (INCLUDES SHUTOFF VALVE)	IPL-57
-1	TBD	• TANKS	IPL-81
90	248672	• TEE, 1/4" BRASS	IPL-57
360	248672	• TEE, 1/4" BRASS	IPL-59
270	248672	• T-FITTING, FEMALE	IPL-57
540	248672	• T-FITTING, FEMALE	IPL-59

INDEX BY PART DESCRIPTION CONT..

FIG ITEM	PART NUMBER.	NOMENCLATURE 123456	PAGE
80	981099	• TILT SCREW	IPL-47
90	851169	• TOOL BOX	IPL-19
90	851169	• TOOL BOX	IPL-21
60	980200	• TORQUE HUB, CONVEYOR DRIVE	IPL-85
350	980110	• TORQUE HUB, TRACK DRIVE	IPL-103
50	980160	• TRACK	IP-101
-1	1NONUMBER1	• TRACK ASSEMBLY, LH	IP-101
-2	2NONUMBER2	• TRACK ASSEMBLY, RH	IP-101
110	981070	• TRACK TENSIONER, W/ REDUCING	IPL-109
-1	TBD	• TRUCK HITCH ASSEMBLY	IPL-117
170	980443	• TUBE, CROSS BRACE	IPL-17
10	983157	• TURNBUCKLE ASSEMBLY, WITH RATCHET	IPL-27
120	851426	• UNIVERSAL REMOTE	IPL-121
110	170071A	• UPPER RADIATOR HOSE	IPL-111
30	980440-04	• VALVE ASSEMBLY	IPL-109
80	980440-02	• VALVE, CHECK	IPL-109
320	982270	• VENT, HYDRAULIC, HIGH FLOW, SM	IPL-77
380	980282	• VENT, RADIATOR COVER	IPL-77
480	982269R	• VENT, RADIATOR COVER	IPL-79
290	980283	• VENT, SIDE COVER	IPL-76
520	982269L	• VENT, SIDE COVER	IPL-79
80	855535	• VIBRATOR	IPL-55
-1	854662	• VIBRATOR ASSEMBLY (SEE FIG 13 FOR NHA)	IPL-55
40	854662	• VIBRATOR ASSEMBLY, SCREED	IPL-39
40	854662	• VIBRATOR ASSEMBLY, SCREED	IPL-35
-1	12NONUMBER120	• VIBRATOR REMOVAL, LH	IPL-35
-1	13NONUMBER230	• VIBRATOR REMOVAL, RH	IPL-39
40	980440-01	• VICKERS FLOW DIVIDE	IPL-109
-1	9NONUMBER110	• WALKBOARD & CROWN ADJUSTMENT REMOVAL	IPL-27
-80	980426L	• WALKBOARD ASSEMBLY, LH COMPLETE	IPL-27
-170	980426R	• WALKBOARD ASSEMBLY, RH COMPLETE	IPL-29
110	980452	• WALKBOARD ASSEMBLY, STAIRWAY	IPL-43
-100	856743L	• WALKBOARD EXTENSION ASSEMBLY, LH	IPL-27
-190	856743R	• WALKBOARD EXTENSION ASSEMBLY, RH	IPL-29
160	980425L	• WALKBOARD EXTENSION WELDMENT, LH DECK	IPL-29
250	980425R	• WALKBOARD EXTENSION WELDMENT, RH DECK	IPL-29
150	856735L	• WALKBOARD PLATE WELDMENT, LH	IPL-27
240	856735R	• WALKBOARD PLATE WELDMENT, RH	IPL-29
150	980428	• WALKBOARD, LID COVER	IPL-37
150	980428	• WALKBOARD, LID COVER	IPL-41
230	140450	• WARNING BUZZER	IPL-105
220	140440	• WARNING LIGHT	IPL-105
120	119-10	• WASHER, 1.0" FLAT	IPL-85
30	119-10	• WASHER, 1.0" FLAT	IP-101
280	119-5	• WASHER, 1/2" FLAT	IPL-76
30	851112	• WASHER, 1/2" FLAT	IPL-117
180	119-5	• WASHER, 1/2" FLAT	IPL-63
60	119-5	• WASHER, 1/2" FLAT	IPL-65
90	119-5	• WASHER, 1/2" FLAT	IPL-65
260	119-5	• WASHER, 1/2" FLAT	IPL-66
210	119-5	• WASHER, 1/2" FLAT	IPL-70
150	119-5	• WASHER, 1/2" FLAT	IPL-76
370	119-5	• WASHER, 1/2" FLAT	IPL-77
470	119-5	• WASHER, 1/2" FLAT	IPL-79
30	119-5	• WASHER, 1/2" FLAT	IPL-85
123	119-5	• WASHER, 1/2" FLAT	IPL-85
30	119-5	• WASHER, 1/2" FLAT	IPL-91
60	119-5	• WASHER, 1/2" FLAT	IPL-91
90	119-5	• WASHER, 1/2" FLAT	IPL-91

ILLUSTRATED PARTS LIST



INDEX BY PART DESCRIPTION CONT..

FIG ITEM	PART NUMBER.	NOMENCLATURE 123456	PAGE
120	119-5	• WASHER, 1/2" FLAT	IPL-91
370	119-5	• WASHER, 1/2" FLAT	IPL-103
400	119-5	• WASHER, 1/2" FLAT	IPL-103
180	119-5	• WASHER, 1/2" FLAT	IPL-124
30	118-5	• WASHER, 1/2" FLAT, LOCK	IPL-95
80	118-5	• WASHER, 1/2" FLAT, LOCK	IPL-95
200	119-1	• WASHER, 1/4" FLAT	IPL-82
230	119-1	• WASHER, 1/4" FLAT	IPL-82
340	119-8	• WASHER, 3/4" - FLAT	IPL-125
150	119-8	• WASHER, 3/4" FLAT	IPL-65
180	118-3	• WASHER, 3/8" FLAT	IPL-119
160	119-3	• WASHER, 3/8" FLAT	IPL-63
210	119-3	• WASHER, 3/8" FLAT	IPL-63
30	119-3	• WASHER, 3/8" FLAT	IPL-69
240	119-3	• WASHER, 3/8" FLAT	IPL-70
270	119-3	• WASHER, 3/8" FLAT	IPL-71
120	119-3	• WASHER, 3/8" FLAT	IPL-75
500	119-3	• WASHER, 3/8" FLAT	IPL-79
540	119-3	• WASHER, 3/8" FLAT	IPL-79
40	119-3	• WASHER, 3/8" FLAT	IPL-81
70	119-3	• WASHER, 3/8" FLAT	IPL-81
110	119-3	• WASHER, 3/8" FLAT	IPL-81
170	119-3	• WASHER, 3/8" FLAT	IPL-82
300	119-3	• WASHER, 3/8" FLAT	IP-83
350	119-3	• WASHER, 3/8" FLAT	IP-83
60	119-2	• WASHER, 5/16" FLAT	IPL-61
60	119-2	• WASHER, 5/16" FLAT	IPL-69
90	119-2	• WASHER, 5/16" FLAT	IPL-69
120	119-2	• WASHER, 5/16" FLAT	IPL-69
150	119-2	• WASHER, 5/16" FLAT	IPL-70
180	119-2	• WASHER, 5/16" FLAT	IPL-70
30	119-2	• WASHER, 5/16" FLAT	IPL-75
60	119-2	• WASHER, 5/16" FLAT	IPL-75
310	119-2	• WASHER, 5/16" FLAT	IPL-76
340	119-2	• WASHER, 5/16" FLAT	IPL-77
400	119-2	• WASHER, 5/16" FLAT	IPL-77
200	116-7	• WASHER, 5/8" FLAT	IPL-88
300	119-7	• WASHER, 5/8" FLAT	IPL-71
80	119-7	• WASHER, 5/8" FLAT	IPL-87
170	119-7	• WASHER, 5/8" FLAT	IPL-97
80	119-7	• WASHER, 5/8" FLAT	IP-101
130	119-7	• WASHER, 5/8" FLAT	IP-101
160	119-7	• WASHER, 5/8" FLAT	IPL-102
260	119-7	• WASHER, 5/8" FLAT	IPL-102
300	119-7	• WASHER, 5/8" FLAT	IPL-103
330	119-7	• WASHER, 5/8" FLAT	IPL-103
70	120-7	• WASHER, 5/8" FLAT	IPL-117
80	118-7	• WASHER, 5/8" FLAT LOCK	IPL-117
130	119-4	• WASHER, 7/16" FLAT	IPL-63
140	119-4	• WASHER, 7/16" FLAT	IPL-82
30	119-9	• WASHER, 7/8" FLAT	IPL-87
150	119-9	• WASHER, 7/8" FLAT	IPL-88
30	930019	• WASHER, FLAT, 3/8" SAE	IPL-47
70	119-4	• WASHER, FLAT, 7/16" SAE	IPL-47
170	118-5	• WASHER, LOCK, 1/2"	IPL-47
40	240391	• WASHER, SCREED SWIVEL MOUNT	IPL-95
90	240391	• WASHER, SCREED SWIVEL MOUNT	IPL-95
-352	980963	• WASHER, TEFLON	IPL-67
400	984543	• WASHER, THRUST	IPL-67

INDEX BY PART DESCRIPTION CONT..

FIG ITEM	PART NUMBER.	NOMENCLATURE 123456	PAGE
210	119-7	• WASHER. 5/8" FLAT	IPL-102
90	119-7	• WASHER. 5/8" FLAT	IPL-121
40	119-7	• WASHER. 5/8" FLAT	IPL-123
110	119-7	• WASHER. 5/8" FLAT	IPL-123
40	854667	• WELD RING, VIBRATOR MOTOR	IPL-55
220	982178	• WELDMENT, TRUCK HITCH	IPL-119
80	920070	• WING BOLT	IPL-61
420	920070	• WING BOLT 3/8"	IPL-77
20	920070	• WING BOLT, 3/8"-11 X 2.0	IPL-47
40	920070	• WING BOLT, 3/8"-11 X 2.0	IPL-47
50	920070	• WINGBOLT, 3/8"	IPL-121
60	920070	• WINGBOLT, 3/8"	IPL-123
240	920070	• WINGBOLT, 3/8"	IPL-124
280	920070	• WINGBOLT, 3/8"	IPL-124
40	982742	• WIRE HARNESS, AUXILLARY	IPL-127
110	982943	• WIRE HARNESS, DASH, LEFT	IPL-127
30	983008	• WIRE HARNESS, DASH, RIGHT	IPL-127
120	982741	• WIRE HARNESS, HYDRAULICS	IPL-127
50	980975	• WIRE HARNESS, PROPEL	IPL-127
70	980975	• WIRE HARNESS, PROPEL	IPL-127
70	980291	• WIREWAY COVER	IPL-69
40	980294	• WIREWAY COVER	IPL-69
180	160040A	• WORK LIGHT	IPL-76
70	9090-1125	• Z BRACKET ARM	IPL-123
40	851423	• Z BRACKET ARM, 1.75"	IPL-121