

LeeBoy

OPERATIONS, SERVICE AND PARTS MANUAL

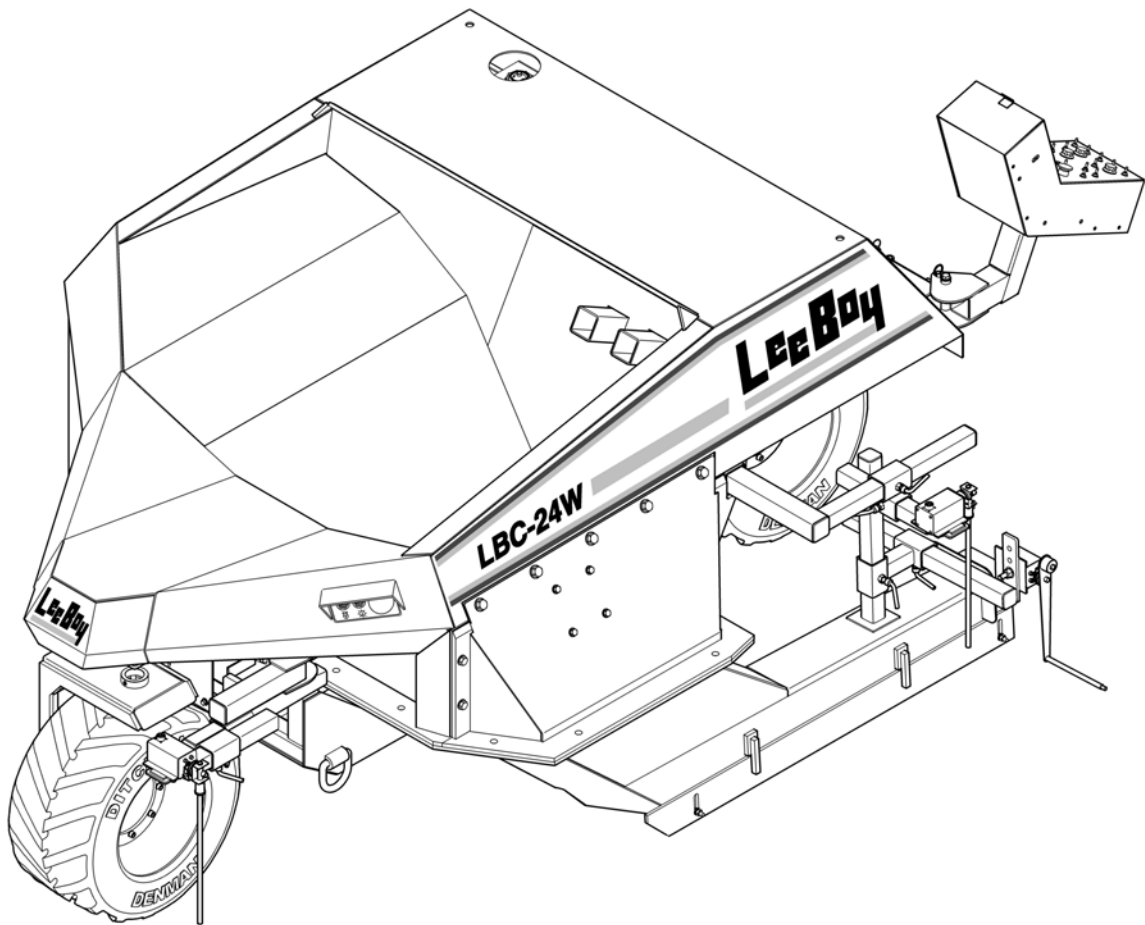

LBC-24W Curber

Manual No. 986621-01

For Units with Serial No. 41933 and higher

Published 09-31-06

USERS' REFERENCE GUIDE

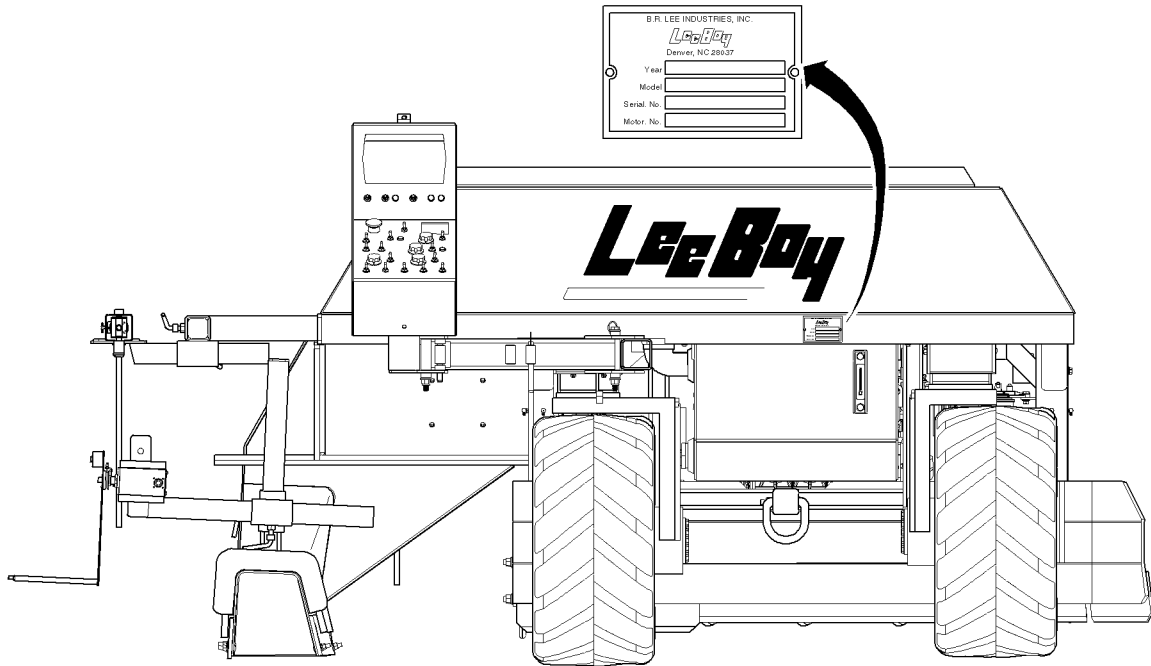

DELIVERY DATE _____

UNIT SERIAL NUMBER _____

ENGINE TYPE _____

ENGINE NUMBER _____

DEALER'S NAME AND ADDRESS

PHONE NUMBER _____

EQUIPMENT HOURS _____

SERVICE MANAGER _____



LIMITED WARRANTY POLICY AND PROCEDURES

WARRANTY

1. If a defect in material or workmanship is found and the authorized dealer is notified during the warranty period, LeeBoy will repair or replace any part of component of the unit or part that fails to conform to the warranty during the warranty period.
2. The warranty date will begin upon the completion of the warranty form by the initial customer and will expire after twelve (12) months have passed. The Warranty Card should be filled out within ten (10) days of delivery of the unit.
3. Engines are warranted by their manufacturers and may have warranty coverage that differs from that of LeeBoy.
4. Replacement parts furnished by LeeBoy are covered for the remainder of the warranty period applicable to the unit or component in which such parts are installed.
5. LeeBoy has the right to repair any component or part before replacing it with a new part.
6. All new replacement parts purchased by a LeeBoy dealer will carry a six (6) month warranty. Remanufactured parts purchased by a LeeBoy dealer will carry a ninety (90) day warranty.

ITEMS NOT COVERED

LeeBoy is not responsible for the following:

1. Charges for travel time, mileage, or overtime.
2. Charges related to transporting the product to and from the place at which warranty work is performed.
3. Airfreight charges related to transporting repair parts to the place at which warranty work is performed.
4. All used units or used parts of any kind.
5. Repairs due to normal wear and tear, or brought about by abuse or lack of maintenance of the equipment, except for premature failures, conveyor chains, polytrack pads, and track rails.
6. Attachments not manufactured or installed by LeeBoy.

7. Liability for incidental or consequential damages of any type including, but not limited to lost profits or expenses of acquiring replacement equipment.
8. Miscellaneous charges.

LIMITATIONS

LeeBoy has no obligation under this warranty for:

1. Any defects caused by misuse, misapplication, negligence, accident or failure to maintain or use in accordance with the most current operating instructions.
2. Unauthorized alterations.
3. Defects or failures caused by any replacement parts or attachments not manufactured by or approved by LeeBoy.
4. Failure to conduct normal maintenance and operating service, including without limitation, providing lubricants, coolant, fuel, tune-ups, inspections or adjustments.
5. Unreasonable delay, as established by LeeBoy, in making the applicable units or parts available upon notification of a service notice ordered by LeeBoy.
6. The warranty responsibility on all engines and/or truck chassis rests with the respective manufacturer.
7. LeeBoy may have support agreements with some engine and/or truck chassis manufacturers for warranty and parts support.

OTHER WARRANTIES

THE FOREGOING WARRANTY IS EXCLUSIVE AND IN LIEU OF ALL OTHER EXPRESSED STATUTORY AND IMPLIED WARRANTIES APPLICABLE TO UNITS, ENGINES, OR PARTS WITH LIMITATION, ALL IMPLIED WARRANTIES OF MERCHANTABILITY OR FITNESS FOR ANY PARTICULAR USE OR PURPOSE. IN NO EVENT, WHETHER AS A RESULT OF BREACH OF CONTRACT OR WARRANTY, OR ALLEGED NEGLIGENCE OR LIABILITY WITHOUT FAULT, SHALL LEEBOY BE LIABLE FOR SPECIAL, INCIDENTAL OR CONSEQUENTIAL DAMAGES, INCLUDING WITHOUT LIMITATION, LOSS OF PROFIT OR REVENUE, COST OF CAPITAL, COST OF SUBSTITUTED EQUIPMENT, FACILITIES OR SERVICES, DOWNTIME COSTS, LABOR COSTS OR CLAIMS OF CUSTOMERS, PURCHASERS OR LESSEES FOR SUCH DAMAGES.

LBC-24W CONCRETE CURBER OPERATIONS, SERVICE AND PARTS MANUAL

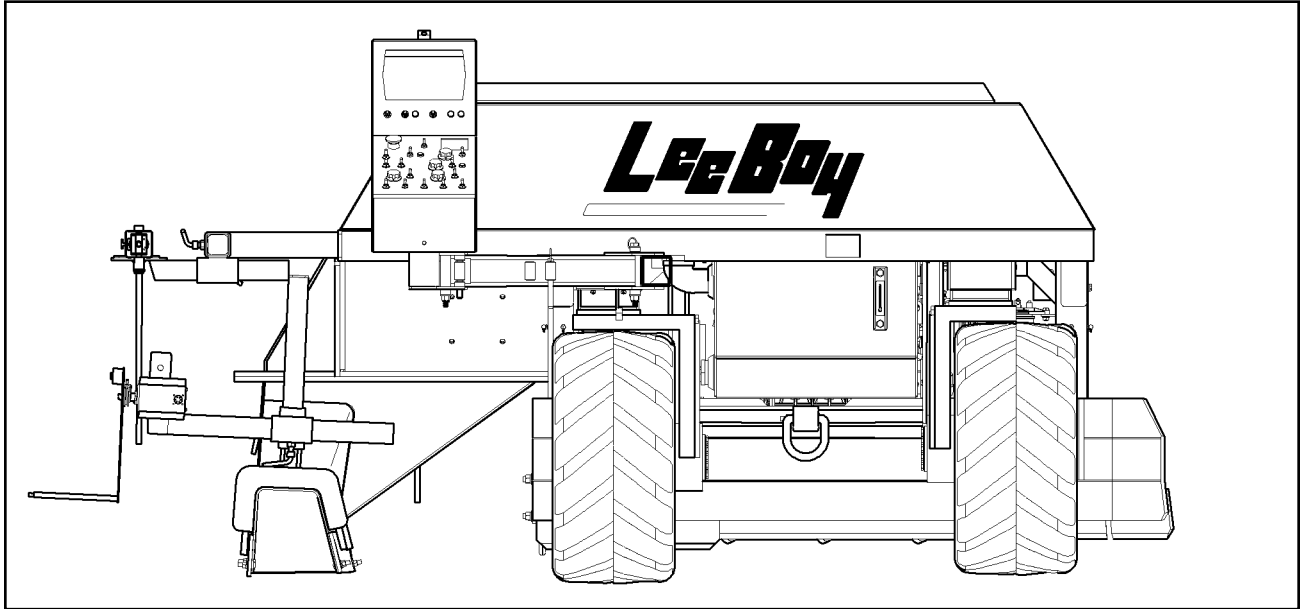

REAR VIEW

This manual should be used with all related supplemental books, engine manual, and parts book. Related Service Bulletins should be reviewed to provide information regarding some of the recent changes.

If any questions arise concerning this publication or others, contact your local LeeBoy Distributor for the latest available information.

Contents of this manual are based on information in effect at the time of publication and are subject to change without notice.

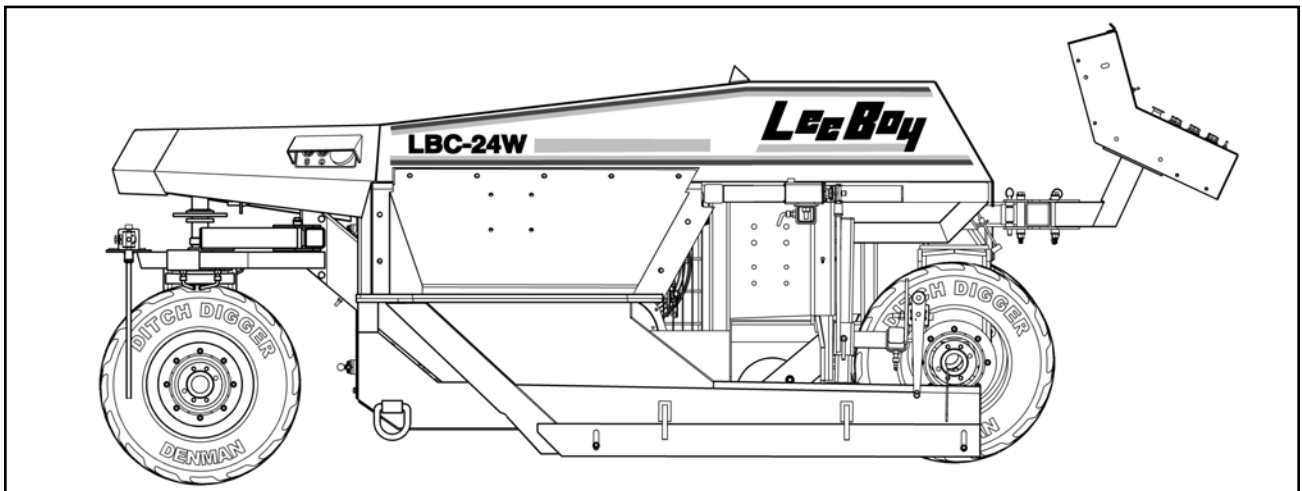

SIDE VIEW



TABLE OF CONTENTS

	Page
INTRODUCTION & SAFETY	
FORWARD	1-2
RECEIVING THE LBC-24W CURBER	1-2
OVERVIEW OF THE MANUAL	1-3
PRECAUTIONARY INSTRUCTIONS	1-4
SAFETY DECALS	1-5
SAFETY	1-6
SPECIFICATIONS	
GENERAL INFORMATION	2-2
SPECIFICATIONS	2-9
OPERATION	
GENERAL INFORMATION	3-2
OPERATING CONTROLS, INDICATORS, AND GAUGES	3-2
PRELIMINARY PROCEDURES	3-9
BREAK-IN PROCEDURES	3-9
PRE-START INSPECTION	3-10
ENGINE OPERATION	3-10
DRIVING THE MACHINE	3-12
SURFACE PREPARATION	3-12
MACHINE PREPARATION	3-13
USING THE TOP-CON SYSTEM	3-14
OPERATING THE MACHINE	3-17
TRANSPORTING THE LBC-24W CURBER	3-18
MAINTENANCE	
GENERAL INFORMATION	4-3
ROUTINE MAINTENANCE	4-3
MAINTENANCE SCHEDULE	4-7
CHECKS AND ADJUSTMENTS	4-7
ENGINE MAINTENANCE	4-8
FUEL SYSTEM	4-8
RADIATOR AND COOLANT SYSTEM	4-10
BATTERY MAINTENANCE	4-11
ELECTRICAL SYSTEM	4-12
STEERING CALIBRATION	4-14
HYDRAULIC SYSTEM	4-14
TIRES AND WHEELS	4-16
STORAGE	4-17
DECAL INSTALLATION	4-18
TROUBLESHOOTING	4-19
SCHEMATICS	4-31
ILLUSTRATED PARTS LIST	SECTION 5



Section 1 INTRODUCTION & SAFETY

TABLE OF CONTENTS

	Page
FORWARD	1-2
RECEIVING THE LBC-24W CURBER	1-2
OVERVIEW OF THE MANUAL	1-3
GENERAL INFORMATION	1-3
INTRODUCTION AND SAFETY	1-3
SPECIFICATIONS	1-3
OPERATION	1-3
MAINTENANCE AND TROUBLESHOOTING	1-3
PRECAUTIONARY INSTRUCTIONS	1-4
MATERIAL SAFETY DATA SHEETS	1-4
SAFETY DECALS	1-5
SAFETY	1-6
PRE-START INSPECTION	1-6
EMERGENCY STOP	1-6
OPERATING SAFETY	1-7
STOPPING SAFETY	1-7
GENERAL MAINTENANCE SAFETY	1-7
BATTERY SAFETY	1-7
TIRE SAFETY	1-7
HANDLING FLUIDS SAFELY	1-8
TRANSPORT	1-8
STORAGE	1-8

Section 1

INTRODUCTION & SAFETY



FORWARD

The LeeBoy LBC-24W Concrete Curb and Gutter machine is a maneuverable, compact machine that enhances job-site productivity, speed and quality. Steering controls turn a smooth radius as tight as 24 inches eliminating time-consuming hand forming. The LBC-24W is designed to cost-effectively slipform curbs and gutters, alley ribbons and sidewalks. The hydrostatic variable speed drive, superior visibility and electronic controls enable a one person operation. The LBC-24W can be used on soil or pavement using a string line or manual controls. Pouring molds can be replaced quickly and easily with the quick-change mold system.

This manual contains the correct operation and routine maintenance procedures needed by the owner/operator for the safe and efficient use of the Leeboy LBC-24W Curber. In order to maximize the performance and efficiency of the Curber, it is VERY IMPORTANT that the owner/operator and maintenance personnel read this manual thoroughly before operating or servicing the machine.

Always keep this manual in a convenient place for instant reference and NEVER attempt to make repairs or adjustments that you do not fully understand. If you require additional information or service, contact your authorized Leeboy dealer. Always give your dealer the Serial Number of your machine when ordering parts or when requesting service or other information.

The technical information found in this manual was correct at the time it was approved for publication. However, due to a continuous program of research and development, some procedures, specifications and parts may be altered in a constant effort to update and improve our products.

Leeboy reserves the right to make design or specification changes without prior notification and to make improvements without incurring an obligation to add them to any machine in existence. Please contact your local authorized Leeboy dealer if you require further assistance.

RECEIVING THE LBC-24W CURBER

The Curber was inspected thoroughly at the factory. However, road hazards or vandalism may occur during transport and result in damage. Inspect the machine as outlined below and perform necessary repairs before placing the machine in service.

1. Check engine oil level as shown in the manufacturer's manual.
2. Check fuel tank, cooling system, engine oil, and hydraulic reservoir for proper levels and contaminants. If contaminants are suspected, flush and fill the system.
3. Read this manual and understand the contents.
4. Check all hydraulic functions and repair or adjust as necessary. Have any repairs or adjustments performed by a qualified mechanic or consult the local dealer.
5. Check for missing parts. If parts are missing or Curber is damaged, consult the local dealer.

OVERVIEW OF THE MANUAL

GENERAL INFORMATION

This manual contains a description of the Curber and its major components, specification information, a description of the controls, operating procedures, maintenance and replacement procedures, and parts lists for the Model LBC-24W Curber.

INTRODUCTION AND SAFETY

Important Safety precautions related to specific areas of the machine and workplace are included to insure your safety, the safety of those around you, and the correct operation of the machine.

SPECIFICATIONS

Refer to SPECIFICATIONS, Section 2 in this manual, for all major system specifications and detailed information on this machine's components and controls.

OPERATION

Refer to OPERATION, Section 3 in this manual, for information needed to operate the Model LBC-24W Curber safely. The operator of this equipment should READ, UNDERSTAND, and FOLLOW the operating instructions. Cautions are provided in the front of this manual and in the OPERATION section.

CAUTION:  Do not attempt to operate the Model LBC-24W Curber unless fully trained in machine operation. Only authorized personnel should operate the Model LBC-24W Curber. All instructions provided in this manual, and on the machine decals must be followed to prevent damage to the equipment and/or injury to operating personnel.

MAINTENANCE AND TROUBLESHOOTING

Refer to MAINTENANCE, Section 4 of this manual, for all maintenance and repair procedures, as well as charts and tables containing important machine-specific information.

CAUTION:  All maintenance instructions provided in this manual should be followed to insure the safety of the personnel performing the maintenance and to prevent damage to the machine.

Section 1

INTRODUCTION & SAFETY



PRECAUTIONARY INSTRUCTIONS

This manual provides important information to familiarize you with safe operating and maintenance procedures. Even though you may be familiar with similar equipment, you **MUST** read and understand this manual before operating this unit.

Safety is everyone's business and is one of your primary concerns. Knowing the guidelines covered in the following paragraphs and throughout Section 1 will help provide for your safety, the safety of those around you, and the machine's proper operation.

LOOK FOR THESE SYMBOLS WHICH POINT OUT ITEMS OF EXTREME IMPORTANCE TO YOU AND YOUR COWORKERS. READ AND UNDERSTAND THE WARNINGS. HEED AND FOLLOW THE INSTRUCTIONS.

Note the use of the words **DANGER**, **WARNING**, **CAUTION** and **ATTENTION** with the message. The appropriate word for each message has been selected using the following guidelines:

DANGER: An immediate and specific hazard which **WILL** result in severe personal injury or death if the proper precautions are not taken.



WARNING: A specific hazard or unsafe practice which **COULD** result in severe personal injury or death if proper precautions are not taken.



CAUTION: Unsafe practices which **COULD** result in personal injury if proper practices are not taken, or as a reminder of good safety practices.



ATTENTION: Equipment on the machine could be damaged through improper performance of an operation, maintenance or repair procedure.



MATERIAL SAFETY DATA SHEETS

In addition, some machines use or contain hazardous chemicals which may require a specific Material Safety Data Sheet (MSDS). If such information is necessary for the safe operation of this machine, those MSDSs are included on the following pages.

SAFETY DECALS

KNOW and UNDERSTAND the content and position of each safety decal.

KEEP the safety decals and signs CLEAN and legible.

REPLACE safety decals and signs that are missing or have become illegible. When replacing or painting machine parts, REPLACE safety decals as necessary. Refer to Decal Installation in Section 4, Maintenance.

OBTAIN replacement decals or signs from your dealer. Refer to the Illustrated Parts List in this manual for a list of part numbers.

The illustrations on this page will aid you in determining the proper location of decals. If you need more explicit instructions for their placement, contact your dealer.

NOTE: It is the responsibility of the owner and operator to make sure that all decals are readable and located on the machine as designated by the manufacturer.

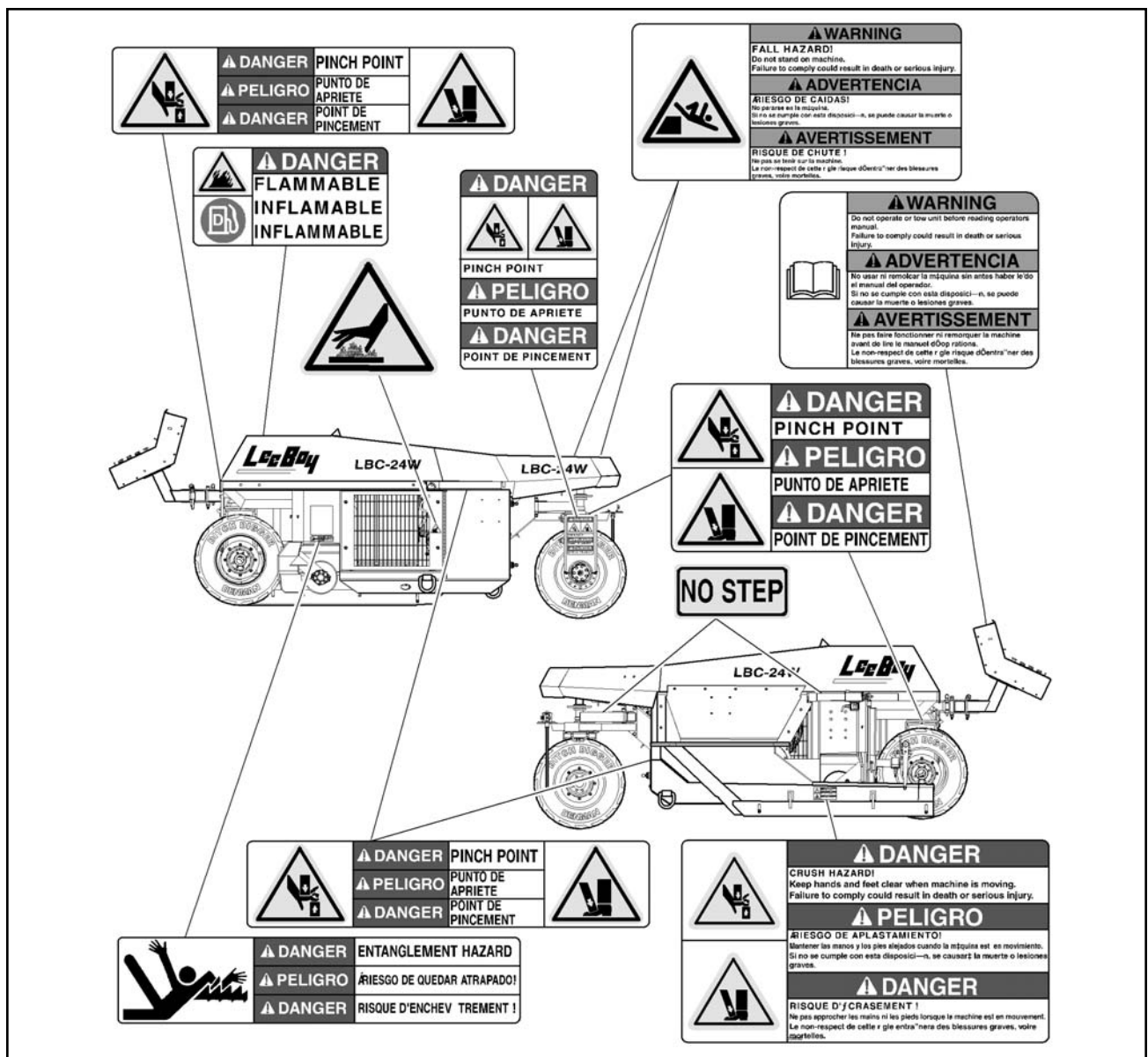

FIGURE 1-1. DECALS AND DECAL LOCATIONS

Section 1 INTRODUCTION & SAFETY



SAFETY

PRE-START INSPECTION

INSPECT machine. Have any malfunctioning, broken or missing parts corrected or replaced before using the machine.

READ and UNDERSTAND the operator's manual as well as all instruction and safety decals.

Have a FIRST AID KIT available and know how to use it.

Have a charged FIRE EXTINGUISHER within reach. Have the correct type for your situation:

TYPE A: Wood, paper, textile, rubbish.

TYPE B: Flammable liquid.

TYPE C: Electrical equipment.

CHECK hydraulic hoses daily for wear and leaks. Replace if damaged.

CHECK engine, transmission, and hydraulic oil levels. Fill to the correct level as necessary.

FILL the fuel tank with the engine off. NEVER fill fuel tank near an open flame, or when smoking.

CHECK for frayed or worn electrical wires and loose or corroded connections.

CHECK tires for wear, cuts, and damage.

INSPECT wheels for loose, damaged, or missing hardware. TIGHTEN as necessary. Refer to the Bolt Torque Charts in Section 4.

CHECK pedals and levers for freedom of movement.

CHECK steps and supports for damage. Repair as necessary.

MAKE SURE all lights, reflectors and other protective devices are clean and operate correctly.

CHECK that all safety decals and signs are in place and readable. These are as important as any other equipment on the machine.

EMERGENCY STOP

Locate the EMERGENCY STOP buttons located on the Main Control Panel at the rear of the machine, and on the Remote Controls at the left front of the machine. In the event of an emergency, push the button to shut down all machine operations. Refer to Engine Start Up in OPERATION for procedures to re-start the engine.

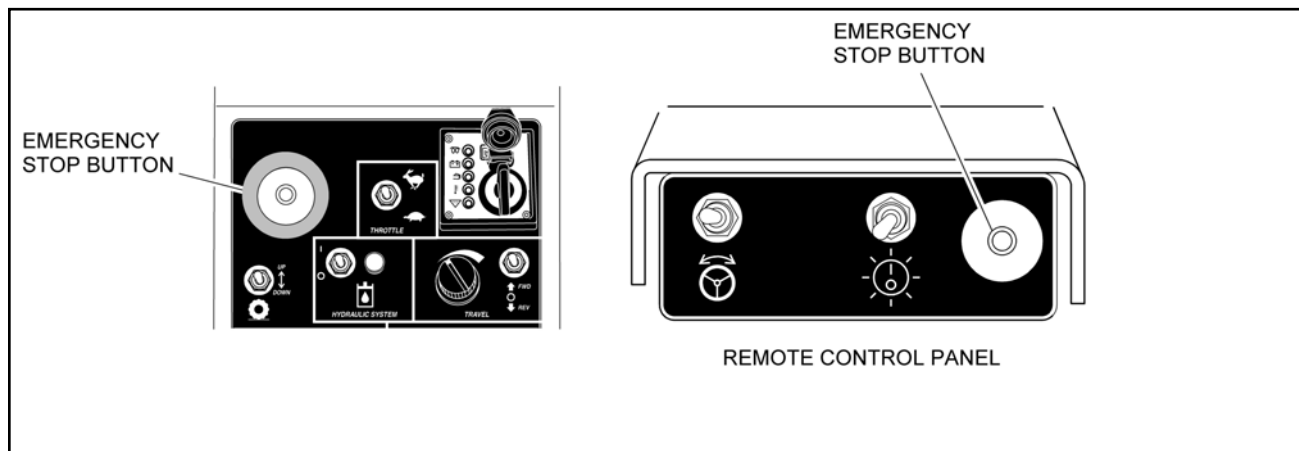

FIGURE 1-2. EMERGENCY STOP BUTTONS



OPERATING SAFETY

WEAR OSHA required safety equipment when operating the machine.

WEAR appropriate ear protection when exposed to loud noise.

DO NOT wear loose fitting clothing, rings or wrist watches that could catch on moving parts.

ALWAYS make sure no person or object is in your line of travel BEFORE starting.

DO NOT allow riders on the machine.

KNOW and UNDERSTAND the job site traffic flow patterns. Work SLOWLY in tight areas and when turning.

DRIVE at speeds compatible with road, weather, and job site conditions.

AVOID steep hills, rough terrain, and sharp turns if possible.

ALWAYS look BEFORE changing your direction of travel.

DO NOT run engine in a closed building for long periods of time.

DO NOT start engine by shorting across starter terminals. Machine will start in gear if normal circuitry is bypassed.

DO NOT leave the engine running without operator present.

STOPPING SAFETY

ALWAYS park the machine on solid, level ground. If this is not possible, always park at a right angle to the slope.

USE proper flags, barriers and warning devices especially when parking in areas of traffic.

GENERAL MAINTENANCE SAFETY

NEVER work on the machine with the engine running.

DO NOT change the engine governor settings.

DO NOT work under the machine unless the machine is supported by approved jacks and jack stands.

ALWAYS replace damaged or lost decals.

REINSTALL safety devices, guards or shields after servicing or adjusting the machine.

CLEAN the service area. KEEP tools and parts off the floor. BE SURE electrical outlets and tools are properly grounded. USE adequate light for the job.

BATTERY SAFETY

DISCONNECT battery cables when working on the electrical system or when welding on the unit.

IF battery needs a charge, be sure battery charger is off when making connections.

BE SURE the correct battery polarity is observed [negative (-) to negative (-) and positive (+) to positive (+)], when connecting a battery charger or jumper cable.

DO NOT tip batteries more than 45 degrees. Electrolyte solution is caustic and explosive.

TIRE SAFETY

DO NOT change tires unless the machine is supported by approved jacks and jack stands.

DO NOT inflate tires. Tires are filled with silicone.

DO NOT hammer on rims with steel hammers. Use rubber, lead, plastic or brass faced mallets.

DO NOT mount a tire without the proper equipment and experience.

Section 1

INTRODUCTION & SAFETY



HANDLING FLUIDS SAFELY

NEVER fill the fuel tank with the engine running.

DO NOT smoke while refueling the machine.

DO NOT fill fuel tank to capacity. Allow room for expansion.

DO NOT use hands to find hydraulic leaks. High-pressure fluid can penetrate the skin, causing severe injury.

TRANSPORT

FOLLOW all local regulations regarding transporting equipment on public roads and highways.

KNOW and USE all required signal devices, including tail lights, slow moving vehicle signs, and warning beacons. Provide an escort when necessary.

BE SURE the lights and reflectors are clean, in good repair and can be seen clearly by all overtaking and oncoming traffic.

Refer to OPERATION, Section 3, for more detailed instructions.

STORAGE

STORE the machine in an area away from human activity.

BE SURE the unit is stored in an area that is firm, level and free of debris.

STORE the machine inside a building, or cover it with a weather-proof tarpaulin and support the wheels securely.

Refer to MAINTENANCE, Section 4, for more detailed instructions.



TABLE OF CONTENTS

	Page
GENERAL INFORMATION	2-2
ENGINE	2-2
Air Cleaner	2-2
Filters	2-3
Radiator	2-3
ELECTRICAL SYSTEM	2-3
HYDRAULIC SYSTEM	2-4
DRIVE SYSTEM	2-5
Brakes	2-5
Steering	2-5
HOPPER	2-6
MOLDS	2-6
CONTROL SENSORS	2-7
COMPUTER CONTROL SYSTEM	2-7
LEVELING BLADE AND AUGER	2-8
AUXILIARY HYDRAULIC PORTS	2-8
OPTIONS	2-8
SPECIFICATIONS	2-9
TABLE 2-1. ENGINE SPECIFICATIONS	2-9
TABLE 2-2. ELECTRICAL SPECIFICATIONS	2-9
TABLE 2-3. MACHINE DIMENSIONS	2-9
TABLE 2-4. DRIVE SYSTEM SPECIFICATIONS	2-10
TABLE 2-5. MACHINE CONTROLS	2-10
TABLE 2-6. POUR PERFORMANCE	2-10
TABLE 2-7. MACHINE SYSTEM CAPACITIES	2-10
TABLE 2-8. FUEL AND LUBRICANT SPECIFICATIONS	2-10

Section 2 SPECIFICATIONS



GENERAL INFORMATION

The descriptions and specifications given in this section are applicable to the LBC-24W Curber. This section contains a description of how the major components operate. It also includes the hydraulic, electrical, performance, and fluid specifications used on this machine.

ENGINE

The LBC-24W Curber uses a Kubota four-cylinder diesel engine to drive the hydraulic pump. The engine is mounted inside the engine compartment located underneath the hopper. The engine is accessed through the engine compartment door and by lifting the hopper.

A fuel pump mounted on the engine draws diesel fuel from the fuel tank. The fuel tank is mounted at the right rear of the machine with a fill cap at the top rear (Figure 2-1). The fuel tank has a shutoff valve installed on the fuel outlet to shut off the fuel during service.

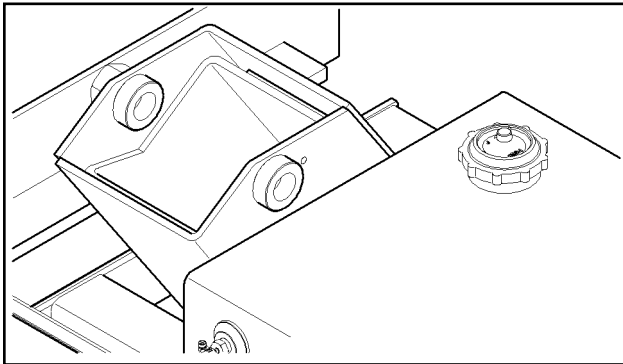

FIGURE 2-1. FUEL SUPPLY

Air Cleaner

An air cleaner is mounted on top of the engine and filters intake air before use by the engine. The air cleaner removes fine particles such as dust, sand, chaff and lint from the air (Figure 2-2).

As air is taken into the air cleaner assembly, a cyclone type action deposits some of the fine particles in the evacuator mounted on the bottom of the air cleaner housing. The evacuator is held closed during engine operation by suction. When the engine is shut off the weight of the debris helps to open the rubber flaps allowing the debris to fall out. The rubber flaps can also be squeezed together for cleaning.

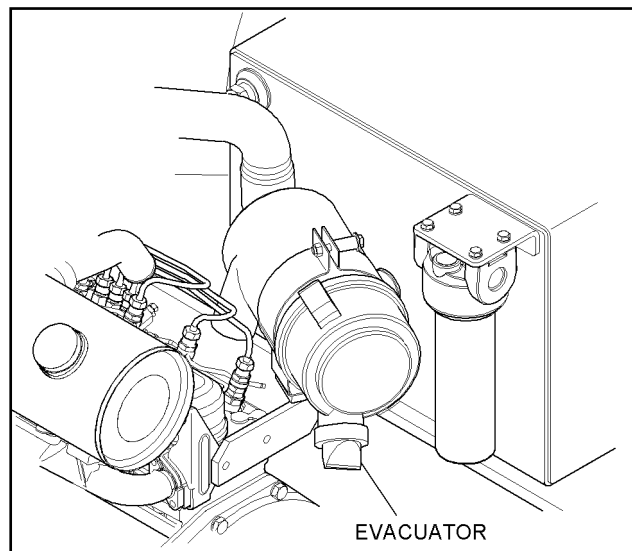

FIGURE 2-2. AIR CLEANER ASSEMBLY

Filters

A fuel filter removes contaminants from the diesel fuel before the fuel flows to the injection pump for injection into the engine combustion chamber. See Figures 2-3 and 2-4 for location of engine fuel and oil filters.

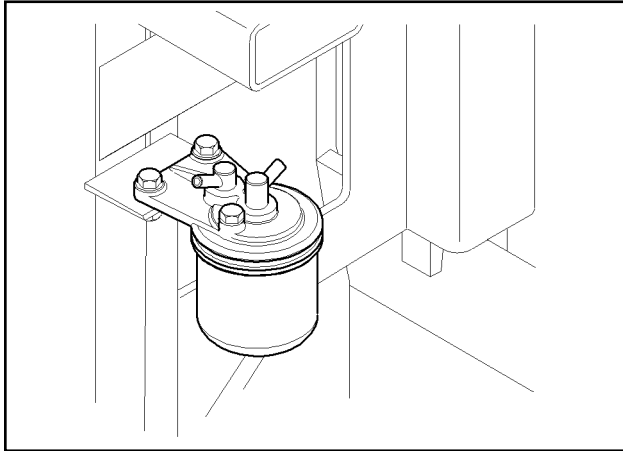

FIGURE 2-3. FUEL FILTER

Radiator

A radiator mounted at the right side of the Curber cools the engine. As coolant flows through the radiator, airflow from the engine driven fan removes heat from the coolant.

Refer to the engine manufacturer's manual for a complete description of the engine.

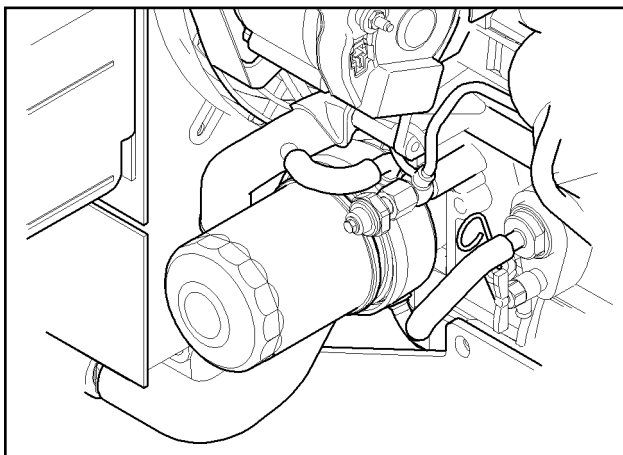

FIGURE 2-4. ENGINE OIL FILTER

ELECTRICAL SYSTEM

The electrical system is powered by a 12-volt battery mounted in the battery compartment located inside the front access door of the machine (Figure 2-5).

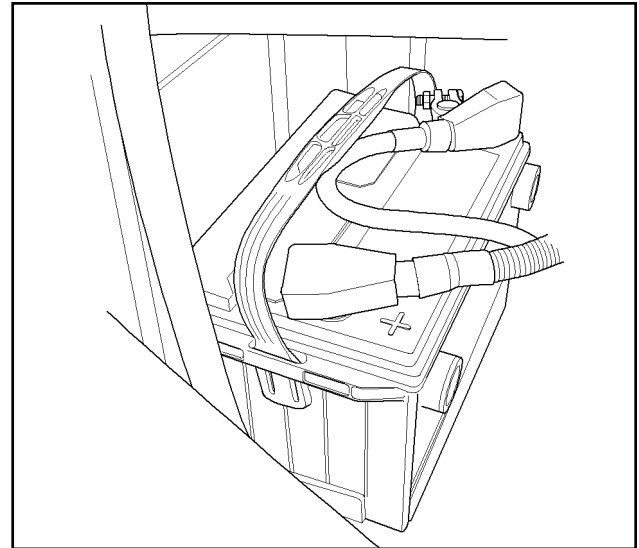

FIGURE 2-5. BATTERY

The battery is 12 volts DC and maintained at 950 cold cranking amperes (CCA). An engine-mounted alternator keeps the battery charged during normal operation.

A warning light mounted on the control panel warns the operator if the battery rate falls to a critical level (Figure 2-6).

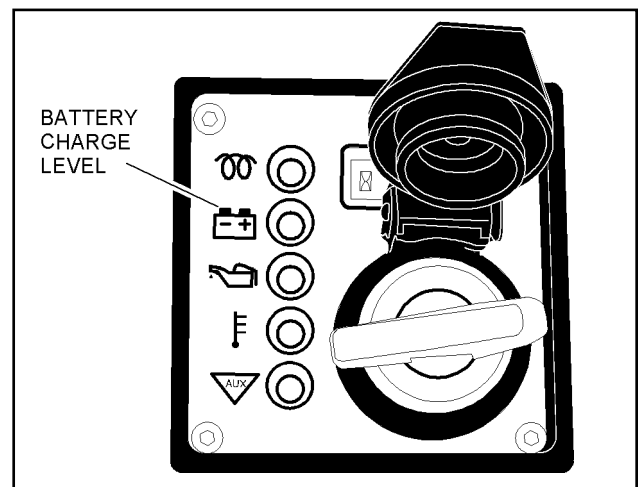

FIGURE 2-6. WARNING LIGHTS

Section 2 SPECIFICATIONS



HYDRAULIC SYSTEM

The hydraulic system includes a hydraulic pump driven by the engine (Figure 2-7). The pump is mounted on the rear of the engine. This variable displacement pump provides hydraulic pressure and flow to operate all the hydraulic components used to control the Curber functions.

The pump draws hydraulic oil from the reservoir (Figure 2-8) and delivers pressurized oil flow to the hydraulic control valve mounted inside the front access door.

The hydraulic reservoir has a sight and temperature gauge installed to check and monitor hydraulic oil conditions (Figure 2-8).

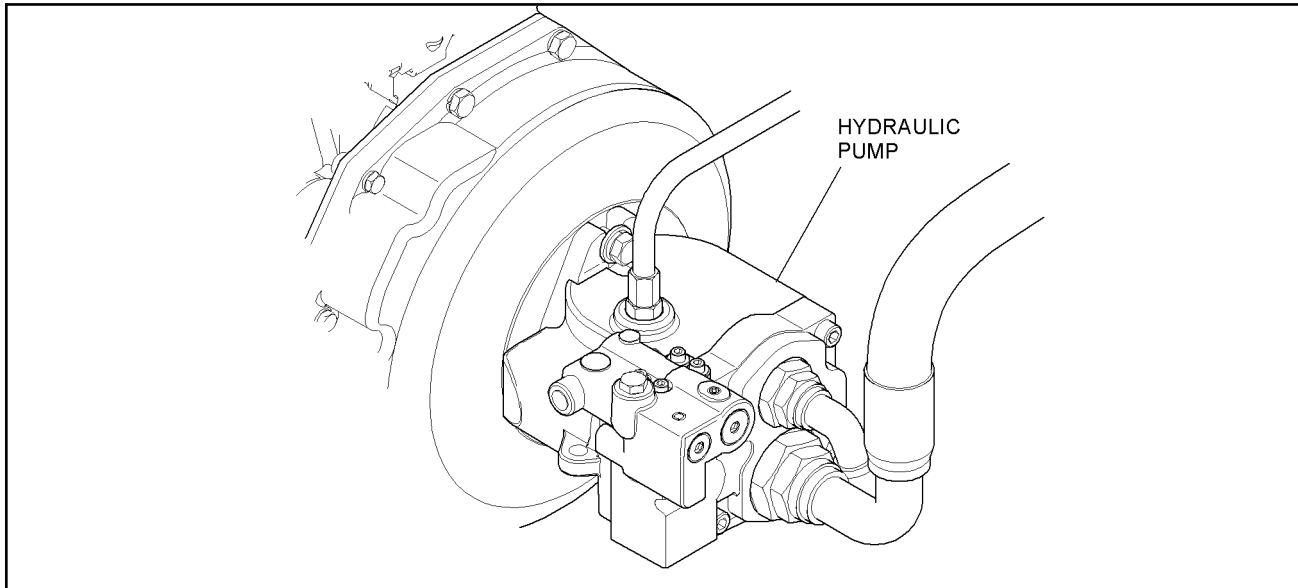

FIGURE 2-7. HYDRAULIC PUMP

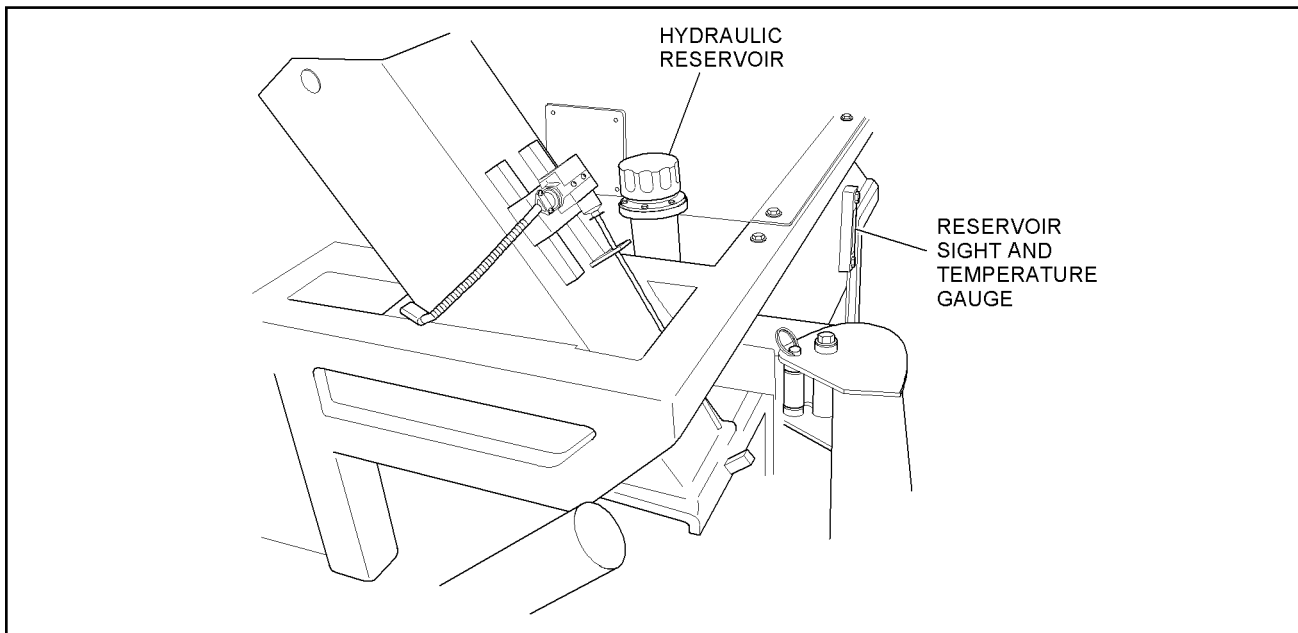

FIGURE 2-8. HYDRAULIC RESERVOIR

DRIVE SYSTEM

The LBC-24W drive system includes three hydrostatic variable speed hydraulic motors, control valve assembly, electronic flow control valve, combiner/divider assembly, and a counterbalance valve.

The drive motors are mounted for all wheel drive. The hydraulic oil pressure to the motors is divided and maintained for smooth operation of the drive wheels.

The drive direction and speed are controlled using a Forward/Reverse Toggle Switch, Drive Torque Adjustment Knob, and Variable Drive Low/High Knob all mounted on the control panel (Figure 2-9).

Brakes

Machine braking is controlled by the flow of hydraulic oil in the drive system. When the drive switch is returned to neutral from forward or reverse position, the flow of hydraulic oil to the drive motor

stops rotating the drive motors allowing the machine to slow and stop.

Steering

The front drive wheel is also used for steering the machine. A hydraulic cylinder mounted between the Curber frame and swiveling wheel mount allows the machine to be turned from left to right. The control valve controls the hydraulic cylinder. A Left/Right Toggle Switch mounted on the control panel (Figure 2-9) allows the operator to manually steer the machine.

The steering can also be controlled by the Top-Con Computer Control System (Figure 2-9). A Steering Computer ON/OFF Toggle Switch mounted on the control panel activates computer controlled steering. Steering sensors located on the left side of the Curber monitor the steering path and send signals to the computer for steering correction. These sensors are selected using the Steering Selector Switch mounted on the control panel.

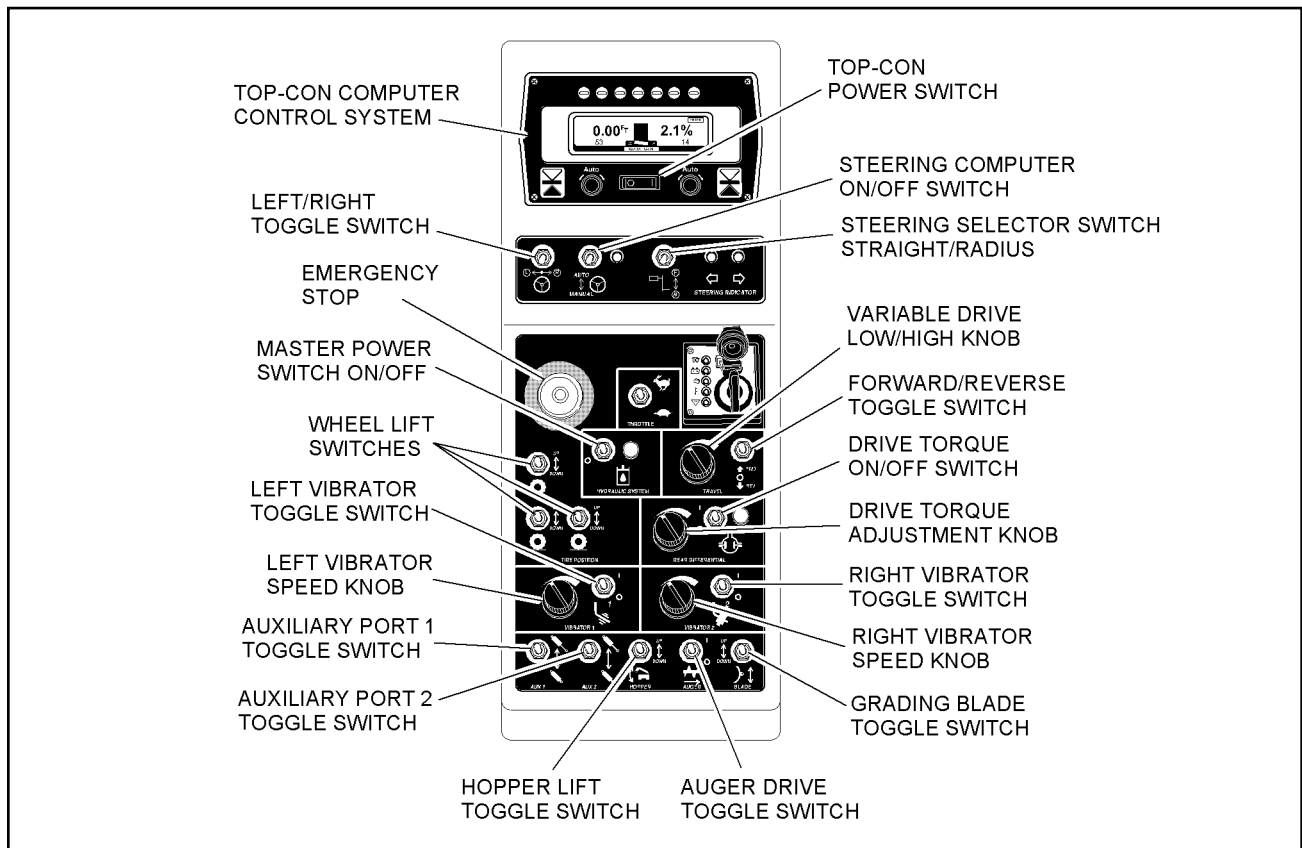

FIGURE 2-9. CONTROL PANEL

Section 2 SPECIFICATIONS



HOPPER

The hopper is mounted on the top of the machine above the mold. The hopper holds the concrete used to form curbs (Figure 2-10).

Dual hydraulically operated vibrators keep the concrete flowing from the hopper to the mold. The operation of the vibrators is controlled by Left and Right Vibrator Toggle Switches mounted on the control panel (Figure 2-9). Left and Right Vibrator Speed Knobs, mounted on the Main Control Panel, control vibrator speed.

MOLDS

Molds mounted on the lower rear section of the hopper determine the final shape and size of the curb (Figure 2-11).

Weights mounted on the rear of the mold help stabilize the mold during curbing operations. Two weights are used when curbing and finishing are being performed at the same time. One weight may be removed during curbing only operations. The operator will make this decision based on the consistency of the concrete being used.

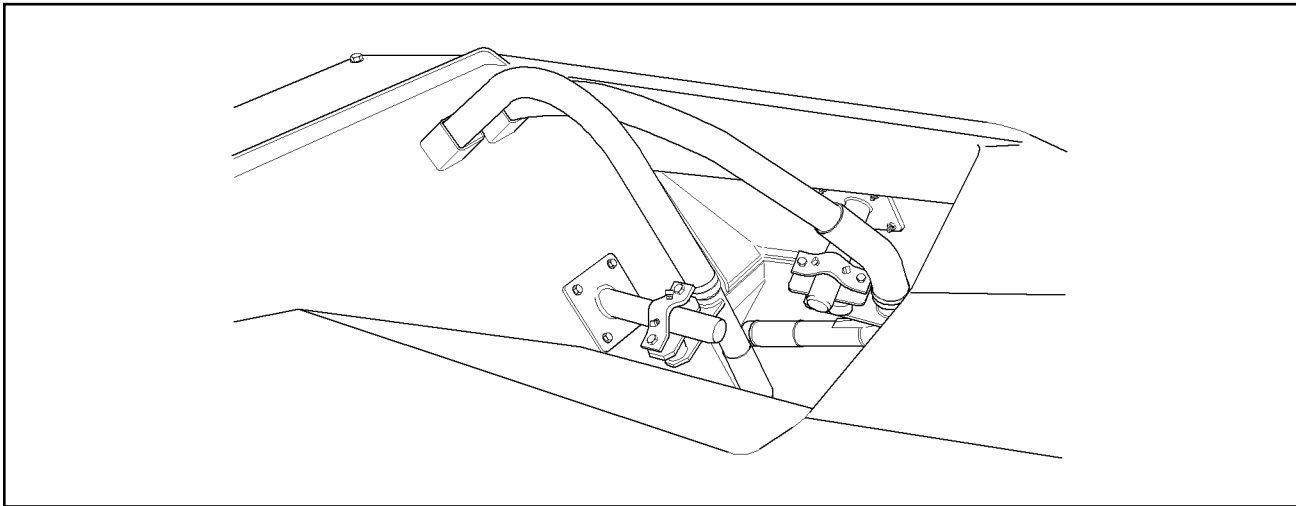

FIGURE 2-10. HOPPER

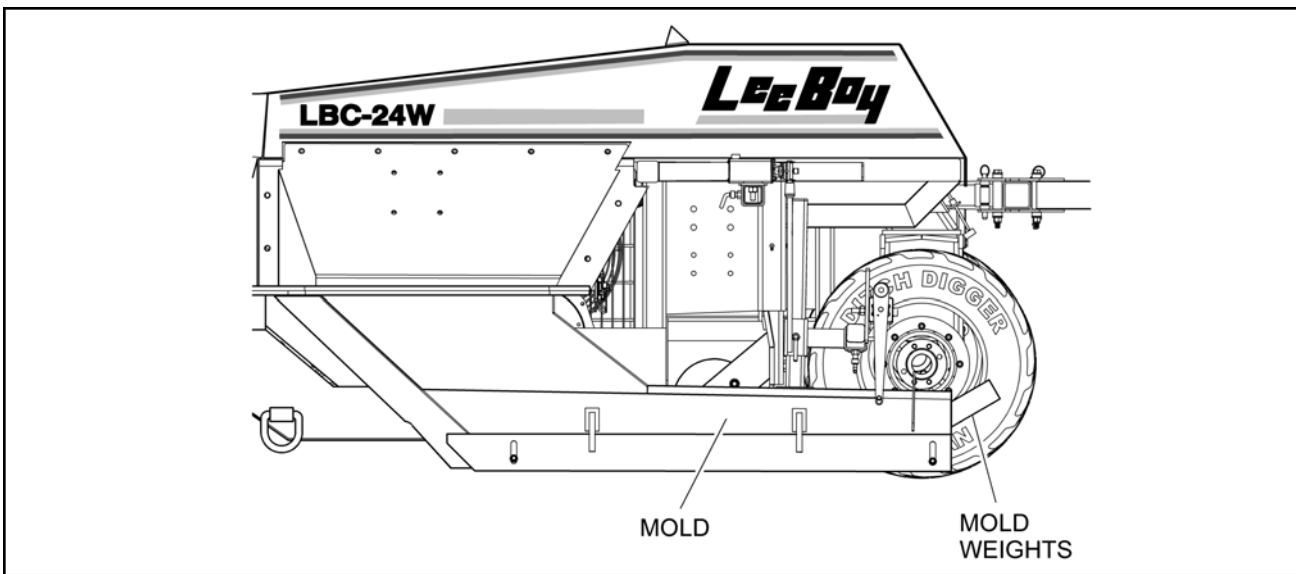

FIGURE 2-11. MOLD

CONTROL SENSORS

The machine can be placed in an automatic mode allowing the Top-Con computer system to control curbing functions. Refer to USING THE TOP-CON SYSTEM in Section 3. Once the curbing parame-

ters are set and the computer system is activated, control sensors mounted on the left side of the machine send signals to the computer indicating the need for steering, height, and slope adjustments (Figure 2-12).

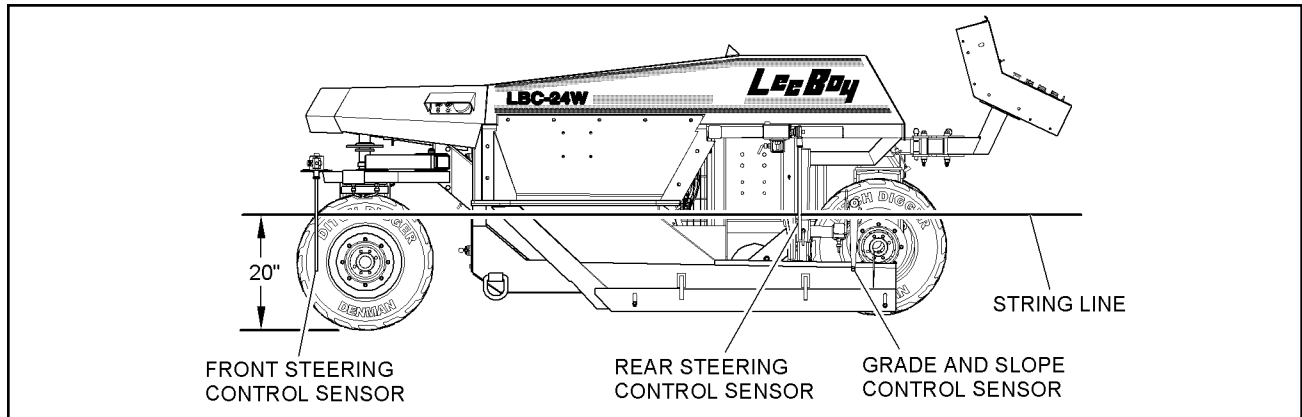

FIGURE 2-12. CONTROL SENSORS

COMPUTER CONTROL SYSTEM

All curbing operations can be preset and performed using the Top-Con computer control system. The computer system is used in conjunction with the control sensors, and is pre-set, adjusted, and monitored using the controls and monitoring screen mounted on the control panel (Figure 2-13).

The sensors ride on a string line installed on the perimeter of the curbing area (Figure 2-12). The sensors signal the computer system when steering, height and slope adjustments are necessary.

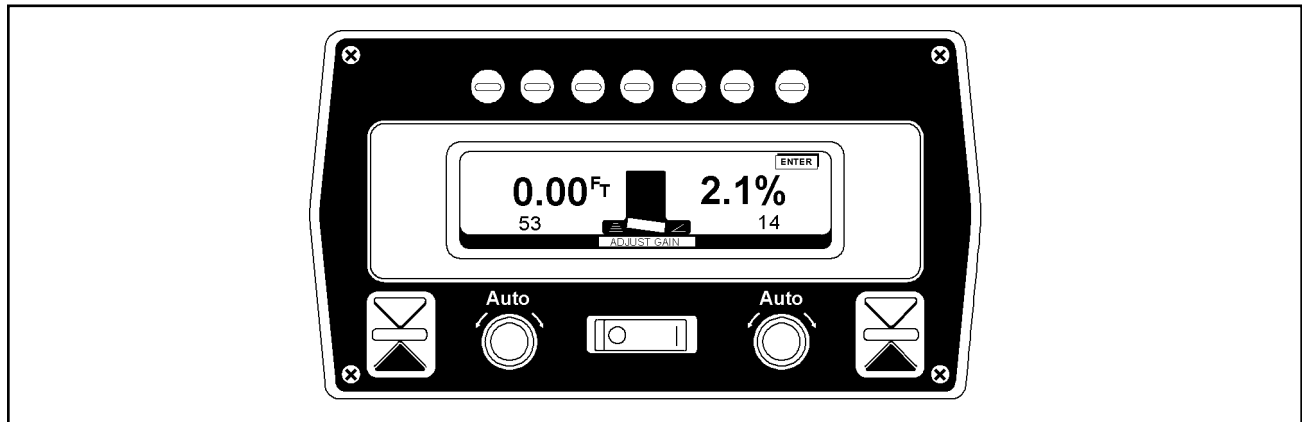

FIGURE 2-13. TOP-CON CONTROL SYSTEM

Section 2

SPECIFICATIONS



LEVELING BLADE AND AUGER

An auger and leveling blade are installed to the front of the rear traction wheels. The leveling blade is intended as a device to provide a level operating surface for the traction wheels. The auger is driven by a hydraulic motor and controlled by the Auger Drive Toggle Switch mounted on the control panel (Figure 2-9). The Grading Blade Switch, mounted on the Main Control Panel, controls the height of the leveling blade.

Curbing surfaces should be pre-graded and level before curbing operations are performed. The leveling blade is used to remove imperfections in the road surface providing a level operating surface for the machine. The auger removes graded material from underneath the machine (Figure 2-14).

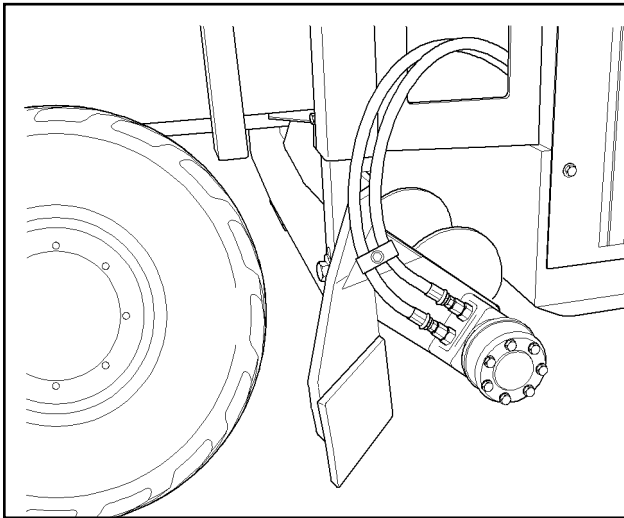

FIGURE 2-14. AUGER AND LEVELING BLADE

AUXILIARY HYDRAULIC PORTS

Two auxiliary hydraulic quick connect ports are provided for the installation of optional equipment such as a driveway cutter installed in the mold or a vector thrust cylinder used in cornering. The auxiliary ports are located on the left side of the machine between the rear of the mold and the Curber.

The auxiliary ports are controlled by Auxiliary Port 1 and Auxiliary Port 2 toggle switches mounted on the control panel (Figure 2-9).

OPTIONS

- Washdown System
- Driveway Cutter
- Vector Thrust Cylinder

SPECIFICATIONS

Tables 2-1 through 2-8 list the engine and system specifications for the LBC-24W Curber. Additional maintenance specification charts can be found in Section 4, MAINTENANCE.

TABLE 2-1. ENGINE SPECIFICATIONS

ITEM	SPECIFICATION
Model	Kubota Diesel Turbo V1505T
Horsepower	44 HP (33 KW)

NOTE: See the engine manufacturer's manual for additional information and specifications.

TABLE 2-2. ELECTRICAL SPECIFICATIONS

ITEM	SPECIFICATION
Battery	12 VDC Maintenance Free
Cold Cranking Amps (CCA)	950 CCA
System Voltage	12 VDC
Charging System	Alternator 12 VDC, 40 Amps

TABLE 2-3. MACHINE DIMENSIONS (SEE FIGURE 2-15)

ITEM	SPECIFICATION
Overall Weight	7,500 pounds (3400 kg)
Overall Length	9 feet 6 inches (2.9 m)
Overall Width	6 feet 4 inches (1.9 m) with 12 inch mold
Overall Height	4 feet (1.2 m)

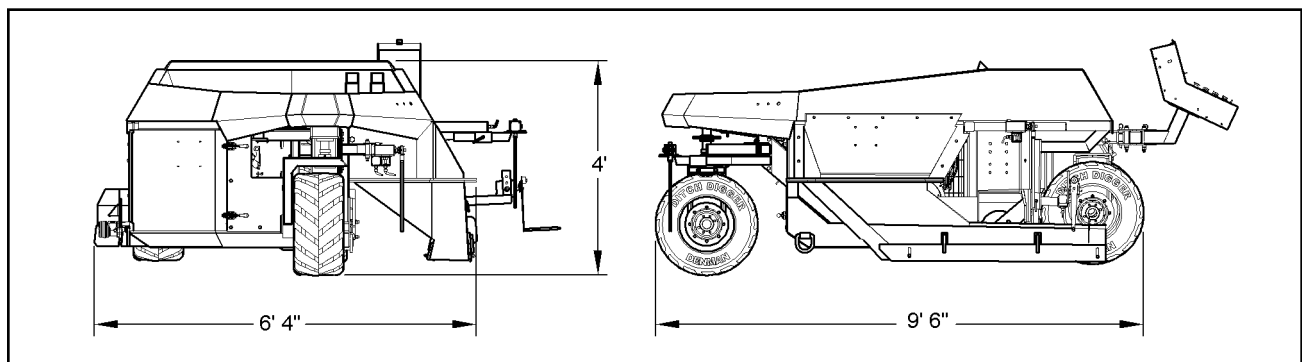

FIGURE 2-15. MACHINE DIMENSIONS

Section 2 SPECIFICATIONS



TABLE 2-4. DRIVE SYSTEM SPECIFICATIONS

ITEM	SPECIFICATION
Steering	Hydraulic Cylinder
Tires	26x12x12 (Silicone Filled)
Comer Gear Box	6:1 Ratio
Radiator/Oil Cooler	Flow-Thru
HYDRAULIC SYSTEM	
Pump Model and Manufacturer	Sauer/Danfoss Series 45
Pump Displacement	2.74 cu. in. (45 cc)
Auger Motor Model and Manufacturer	Sauer/Danfoss Series DS (200 cc)
Drive Motor Model and Manufacturer	Sauer/Danfoss Series OMH (315 cc)

TABLE 2-5. MACHINE CONTROLS

ITEM	SPECIFICATION
Controls	Top-Con Electronic Control System
Vibration	(2) Minnich (up to 10,000 VPM)
Drive system	Hydrostatic

TABLE 2-6. POUR PERFORMANCE

ITEM	SPECIFICATION
Mold Width	48 inches (1.2 m) maximum
Mold Height	24 inches (0.61 m) maximum
Minimum Radius	24 inches (0.61 m)
Minimum Clearance	2 inches (5.1 cm)
Grading Width	5 feet (1.5 m)

TABLE 2-7. MACHINE SYSTEM CAPACITIES

ITEM	SPECIFICATION
Fuel	20 gallons (75.7 L)
Hydraulic	20 gallons (75.7 L)

TABLE 2-8. FUEL AND LUBRICANT SPECIFICATIONS

ITEM	SPECIFICATION
Engine Oil	See engine manufacturer's manual
Hydraulic Oil	AW32
Coolant	50/50 water/ethylene glycol or propylene glycol
Fuel	Diesel, local low-sulfur blend
Grease	Shell Avania EP Grease
Gear Oil	50W Gear Lubricant

TABLE OF CONTENTS

	Page
GENERAL INFORMATION	3-2
OPERATING CONTROLS, INDICATORS, AND GAUGES	3-2
TABLE 3-1. MAIN CONTROL PANEL	3-4
TABLE 3-2. IGNITION SWITCH PANEL	3-7
TABLE 3-3. REMOTE CONTROLS	3-8
PRELIMINARY PROCEDURES	3-9
ADJUSTING CONTROL PEDESTAL	3-9
BREAK-IN PROCEDURES	3-9
PRE-START INSPECTION	3-10
ENGINE OPERATION	3-10
STARTING THE ENGINE	3-10
Preliminary	3-10
Engine Start Up	3-10
Engine Warm Up	3-10
Cold Weather Engine Start Up	3-11
Cold Weather Engine Warm Up	3-11
Using Booster Battery - 12 Volt System	3-11
STOPPING THE ENGINE	3-11
EMERGENCY STOPPING	3-11
ADJUSTING ENGINE FOR HIGH ELEVATION	3-12
DRIVING THE MACHINE	3-12
MANUAL DIRECTIONAL CONTROL	3-12
TRAVEL SPEEDS	3-12
THROTTLE CONTROL	3-12
BRAKING	3-12
PARKING THE MACHINE	3-12
SURFACE PREPARATION	3-12
MACHINE PREPARATION	3-13
MOLD INSTALLATION	3-13
INITIAL SETUP	3-13
USING THE TOP-CON SYSTEM	3-14
BASIC OPERATION	3-14
CONTROL MODE	3-14
Menu Selection Soft Keys	3-15
SETUP MODE	3-16
Adjust Valve Offsets	3-16
Measurement Units	3-17
Check Hourmeters	3-17
Adjust LED Brightness	3-17
System Test	3-17
Beeper On/Off	3-17
OPERATING THE MACHINE	3-17
TRANSPORTING THE LBC-24W CURBER	3-18

Section 3 OPERATION



GENERAL INFORMATION

This section provides the Operating instructions for the LBC-24W Curber. Before starting or operating the machine, it is important to READ, UNDERSTAND, and FOLLOW all Operating instructions, Danger, Warning, and Caution messages in this manual as well as all Safety information contained in Section 1 of this manual.

DANGER:  Failure to observe the Operating instructions, Danger, Warning, and Caution messages in this manual can cause serious injury or death. Only authorized personnel, who are fully trained in the machine operation, can operate the LBC-24W Curber.

This machine should be kept in good mechanical condition at all times.

WARNING:  Do not operate a machine needing repair. Put an information tag on the instrument panel that says, "DO NOT OPERATE". Remove the key from the ignition switch. Repair all damage at once. Minor damage can result in major system failures.

OPERATING CONTROLS, INDICATORS, AND GAUGES

WARNING:  Do not start or operate the LBC-24W Curber before reading, understanding, and following all information given in this section and shown on the machine. The operator must read and understand the function of all controls, indicators, and gauges before starting the engine. Serious injury or death can result if these procedures are not followed.

The operating controls for the LBC-24W Curber are shown in Figures 3-1, 3-2, and 3-3. Their functions are listed in Tables 3-1, 3-2, and 3-3. The controls and indicators are mounted on the Main Control Panel at the rear of the machine. Remote controls are mounted on the left side front of the machine.

The Main Control Panel located on the control pedestal contains indicator lamps for monitoring engine operation, ignition switch, system control switches, throttle control, and the Top-Con computer control system (Figure 3-1).

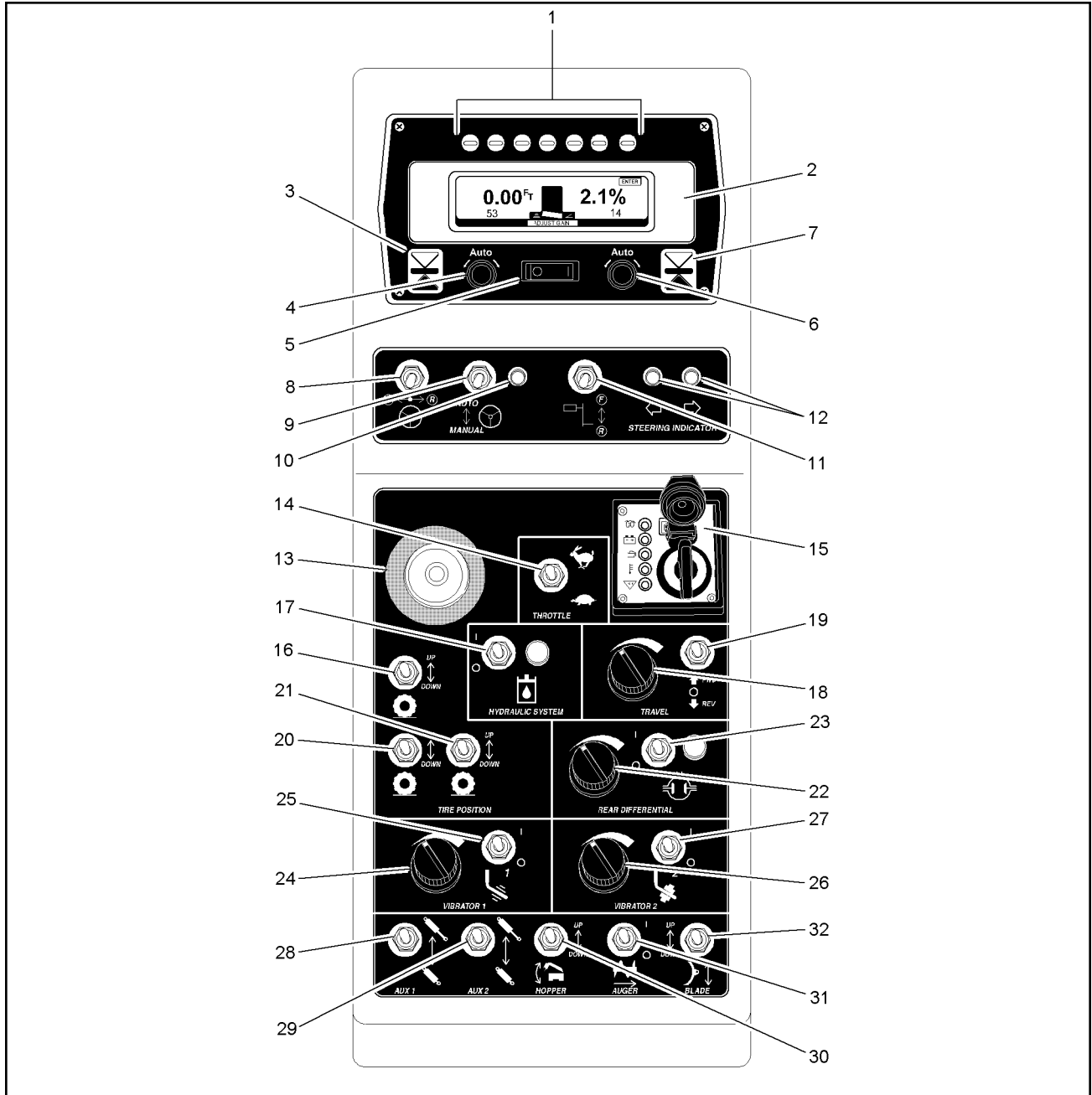

FIGURE 3-1. MAIN CONTROL PANEL

Section 3 OPERATION



TABLE 3-1. MAIN CONTROL PANEL

FIG REF	ITEM	CONTROL NAME	TYPE	FUNCTION
3-1	1	Menu Selection Keys	Touch screen button	Used to select various menu options available when the Top-Con computer is activated.
3-1	2	Display Screen	Display screen	Displays menus and options available when the Top-Con computer is activated.
3-1	3	Left Gain Arrow	Indicator lights Yellow - Down Green - no change Red - Up	Indicates operation in AUTO mode. Flashes red to indicate gain adjustment for the left side of the machine. Flashes green to indicate operation at preset value. Flashes yellow to indicate decrease adjustment left side.
3-1	4	Curb Side Auto	Rotating knob	When the GAIN key is selected on the display screen menu the operator uses this knob to make adjustments to the left elevation valve. The gain setting is displayed on the display above the knob. Adjustments can be made while the machine is under full automatic control. The Top-Con system must be activated and GAIN touch screen button pressed.
3-1	5	Top-Con Power	ON/OFF two-position rocker switch	Power switch for the Top-Con System Five.
3-1	6	Cross Slope Side Auto	Rotating knob	When the GAIN key is selected on the display screen menu the operator uses this knob to make adjustments to the right slope valve. The gain setting is displayed on the display above the knob. Adjustments can be made while the machine is under full automatic control. The Top-Con system must be activated and GAIN touch screen button pressed.
3-1	7	Right Gain Arrow	Indicator lights Yellow - Down Green - no change Red - Up	Indicates operation in AUTO mode. Flashes red to indicate gain adjustment for the right side of the machine. Flashes green to indicate operation at preset value. Flashes yellow to indicate decrease adjustment right side.
3-1	8	Steering Switch	Left/Neutral/Right momentary three-position toggle switch	Used to manually control machine steering.
3-1	9	Steering Computer Switch	ON/OFF two-position toggle switch	Used to activate computer controlled steering.
3-1	10	Steering Computer Light	Indicator light	When illuminated indicates computer steering is selected.

TABLE 3-1. MAIN CONTROL PANEL (CONTINUED)

FIG REF	ITEM	CONTROL NAME	TYPE	FUNCTION
3-1	11	Steering Sensor Selector Switch	Front/Neutral/Rear three-position toggle switch	Switch used in conjunction with the Steering Computer switch to activate the steering sensing system.
3-1	12	Turn Indicators	Indicator lights	Both lights are on when machine is going straight.
3-1	13	Emergency Stop	ON/OFF push/pull knob	When pushed all machine operations stop. Used as a safety device to stop machine in an emergency situation. Pull to reset.
3-1	14	Throttle	Up/Detented Center/Down three-position toggle switch	Push up in gradual momentary adjustments to increase engine speed (RPM). Push down to decrease engine speed (RPM). Holding the switch in the up or down position will increase or decrease engine speed to its maximum/minimum.
3-1	15	Ignition Switch Panel	Key switch & indicator lights	See Items 1 - 7 for Figure 3-2 in left column.
3-1	16	Front Wheel Lift Switch	Up/Neutral/Down momentary three-position toggle switch	Used to lift and lower the front of the hopper.
3-1	17	Master Power Switch	ON/OFF two position toggle switch & indicator light	Used to activate power to the hydraulic clutch and Top-Con control system. Indicator light illuminates when system is activated.
3-1	18	Variable Drive Control	Low-to-high rotating knob	Used to control variable drive speed available to the three wheel drive motors.
3-1	19	Forward/Reverse Switch	Forward/Neutral/Reverse three-position On/Off/On toggle switch	Used to shift the drive motor direction from forward to reverse. Hold switch in the forward or reverse position for manual driving.
3-1	20	Left Lift	Up/Down momentary three-position toggle switch	Used manually to lift and lower the left side of the machine for leveling.
3-1	21	Right Lift	Up/Down momentary three-position toggle switch	Used manually to lift and lower the right side of the machine for leveling.
3-1	22	Drive Torque Adjustment	Low-to-high rotating knob	Used to control torque available from the left rear wheel drive motor.
3-1	23	Drive Torque Switch and Light	ON/OFF two-position toggle switch & power indicator light	Used for optional equipment installation.
3-1	24	Left Vibratory Speed Control	MIN - MAX rotating knob	Used to control vibration emitted by the hopper left vibrator.
3-1	25	Left Vibrator Switch	ON/OFF two-position toggle switch	Used to activate the hopper left vibrator.
3-1	26	Right Vibratory Speed Control	MIN - MAX rotating knob	Used to control vibration emitted by the hopper right vibrator.

Section 3 OPERATION



TABLE 3-1. MAIN CONTROL PANEL (CONTINUED)

FIG. REF	ITEM	CONTROL NAME	TYPE	FUNCTION
3-1	27	Right Vibrator Switch	Two-position toggle switch	Used to activate the hopper right vibrator.
3-1	28	Auxiliary-1 Port	Three-position toggle switch	Used to control optional equipment or tools installed in the auxiliary 1 hydraulic port.
3-1	29	Auxiliary-2 Port	Three-position toggle switch	Used to control optional equipment or tools installed in the auxiliary 2 hydraulic port.
3-1	30	Hopper Lift Switch	Up/Neutral/Down momentary three-position toggle switch	Used to lift and lower the hopper for maintenance, service, or installation of a mold.
3-1	31	Auger Drive Switch	ON/OFF two-position toggle switch	Used to activate the auger drive.
3-1	32	Grading Blade Switch	Up/Neutral/Down momentary three-position toggle switch	Used to lift and lower the grading blade.

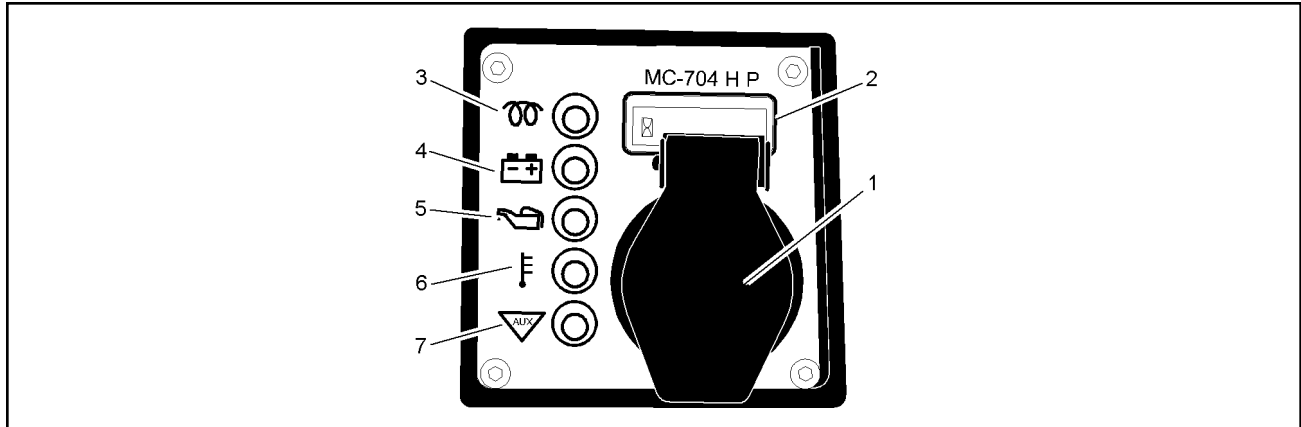

FIGURE 3-2. IGNITION SWITCH PANEL

The ignition switch panel is mounted on the control panel (Figure 3-1, item 15).

TABLE 3-2. IGNITION SWITCH PANEL

FIG REF	ITEM	CONTROL NAME	TYPE	FUNCTION
3-2	1	Ignition Switch Panel	Four-position key switch OFF-GLOW PLUGS-RUN- START	Used to activate switched power circuit and start the engine.
3-2	2	Hour Meter	LCD display	Activated by the switched power circuit of the ignition switch.
3-2	3	Glow Plugs	Indicator light	When the ignition switch is placed in the GP position, indicator light flashes until glow plugs reach operating temperature. When light stops flashing engine can be started.
3-2	4	Battery	Indicator light	Illuminates when ignition is in the RUN position without starting engine to test operation. Illuminates during engine operation to indicate low battery charge or low charging rate.
3-2	5	Engine Oil	Indicator light	Illuminates when ignition is in the RUN position without starting engine to test operation. Illuminates during engine operation to indicate low engine oil pressure.
3-2	6	Temperature	Indicator light	Illuminates when ignition is in the RUN position without starting engine to test operation. Illuminates during engine operation to indicate high engine coolant temperature.
3-2	7	AUX	Option	Used to install optional equipment or warning device.

Section 3 OPERATION

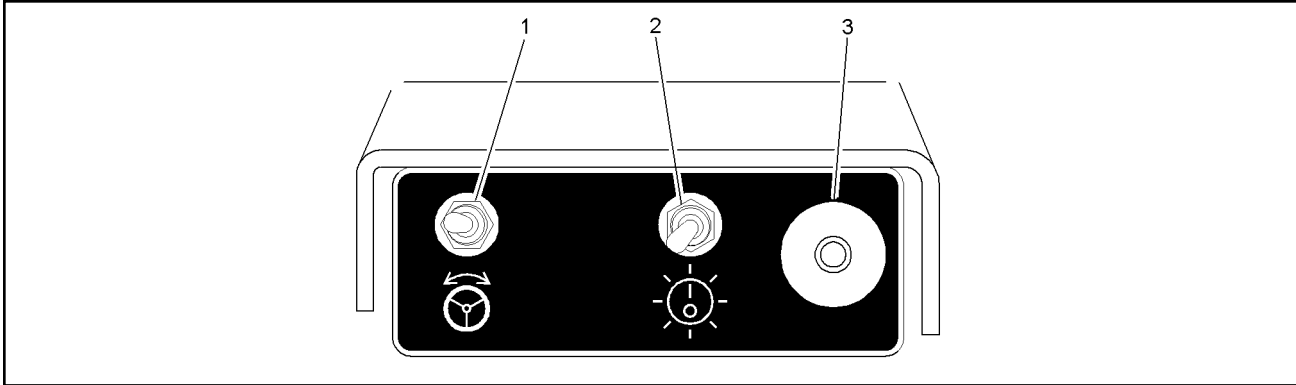

FIGURE 3-3. REMOTE CONTROLS

The remote controls are mounted on the left side front of the machine.

TABLE 3-3. REMOTE CONTROLS

FIG. REF	ITEM	CONTROL NAME	TYPE	FUNCTION
3-3	1	Remote Steering	Right/Left momentary three-position toggle switch	Allows the operator to remotely steer the Curber from the left front of the machine.
3-3	2	Remote Power	ON/OFF two-position toggle switch	Allows the operator to remotely control system power from the left front of the machine.
3-3	3	Emergency Stop	ON/OFF push/pull knob	When pushed all machine operations stop. Used as a safety device to stop machine in case of an emergency situation. Pull to reset.

PRELIMINARY PROCEDURES

Before starting or operating the machine, it is important to READ, UNDERSTAND, and FOLLOW all Operating instructions, Danger, Warning, and Caution messages in this section, as well as all Safety information contained in Section 1 of this manual.

Recommended fluid types and required quantities are listed in Specifications, Section 2 of this manual.

ADJUSTING CONTROL PEDESTAL

Adjust the control pedestal by removing the lock pins (Figure 3-4) and moving the pedestal to the desired position. After placing the pedestal in position insert lock pins.

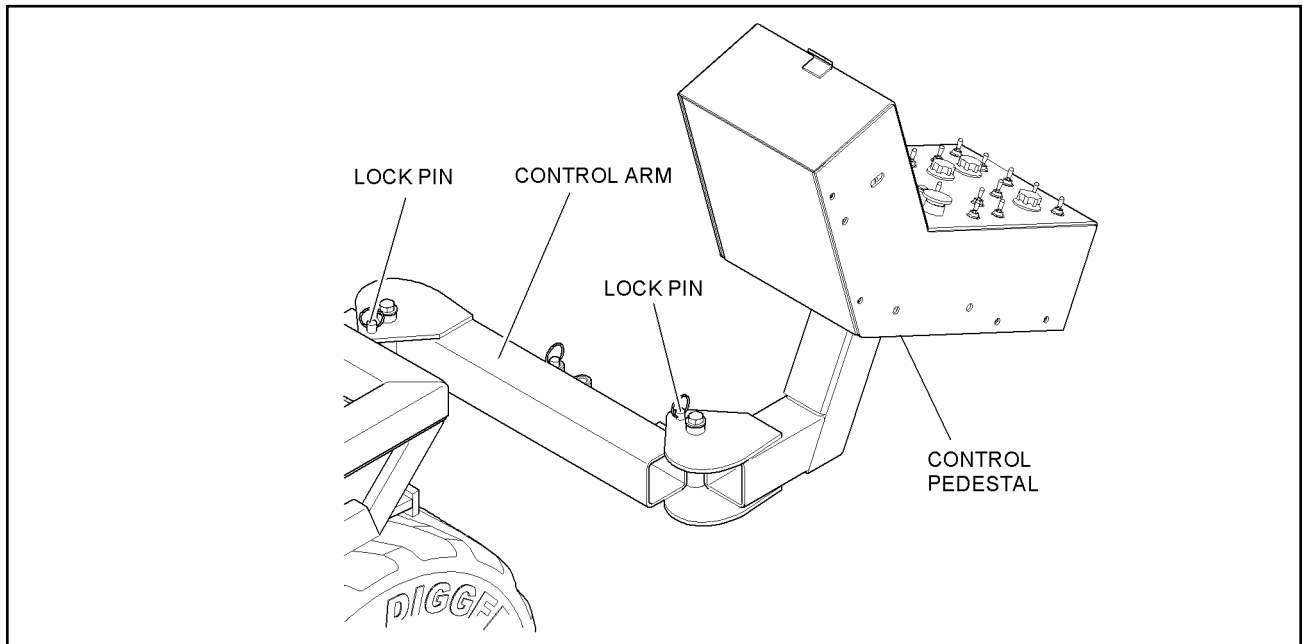

FIGURE 3-4. CONTROL PEDESTAL

BREAK-IN PROCEDURES

NOTE: Make every effort to become familiar with the feel and sound of the machine.

1. Observe engine operation carefully.
2. Check the engine oil and coolant frequently.
3. Operate engine at normal loads.
4. Check indicators and gauges frequently during operation.
5. Avoid excessive engine idling.
6. Perform 10 hour or daily service.
7. Watch for fluid leaks and repair immediately.
8. Check and tighten wheel bolts. Tighten to 35 - 40 ft. lbs. (60 - 68 Nm).
9. Perform service intervals as indicated in Section 4.
10. Check engine manufacturer's manual for additional information of engine break-in.

Section 3 OPERATION



PRE-START INSPECTION

INSPECT machine. Have any malfunctioning, broken or missing parts repaired or replaced before using the Curber.

CHECK hydraulic hoses daily for wear and leaks. Replace if damaged.

CHECK that all the instruction and safety labels are in place and readable. These are as important as any other equipment on the machine.

READ and FOLLOW all instruction decals.

WEAR OSHA required safety equipment when running the Curber.

CHECK engine, and hydraulic oil levels. Fill to the correct level as necessary.

FILL the fuel tank with the engine off. NEVER fill fuel tank near an open flame or when smoking.

CHECK for frayed or worn electrical wires and loose or corroded connections.

CHECK tires for wear, cuts, and damage. INSPECT wheels for loose, damaged, or missing hardware.

CHECK controls for freedom of movement.

CHECK supports for damage. Repair as necessary.

ENGINE OPERATION

STARTING THE ENGINE

Preliminary

Before starting the engine:

1. Check the fuel level. Fill fuel tank daily to avoid condensation.
2. Check the fuel lines and tank for leaks.
3. Check the engine oil level.

ATTENTION: Failure to maintain correct engine oil level is the greatest single cause of engine failures.



4. Check the hydraulic oil level.

Refer to engine manufacturer's manual for instructions when starting engine for the first time. Follow engine manufacturer's recommendations for fuel and oil.

Engine Start Up

CAUTION:



Place the FORWARD/REVERSE switch (Figure 3-1, item 19) in neutral to prevent the machine from moving during start up. The operator or other personnel could be injured if the machine runs into them.

1. Make sure that the auger switch (Figure 3-1, item 31) is in the OFF position.
2. Place the Master Power switch (Figure 3-1, item 17) in the OFF position (Green light OFF).
3. Place throttle control to 1/3 position.
4. Place ignition switch in the GP (glow plug) position until the GP light (Figure 3-2, item 3) stops flashing.

ATTENTION: Do not operate the starter longer than 20 seconds. If the engine does not start, allow the starter to cool for 2 to 3 minutes.



5. Turn ignition switch to START position. Release key when engine starts.
6. Run engine at 1/3 speed for 30 seconds.
7. Check indicator and gauge operation. All indicator lights (Figure 3-2) should be OFF.
8. Turn the Master Power switch (Figure 3-1, item 17) ON.

Engine Warm Up

NOTE: Allow the engine to warm up for several minutes before moving the Curber. The warm up will give the hydraulic oil time to warm, providing for more efficient operation.

1. Start engine and run at 1/3 throttle for several minutes. Do not accelerate rapidly during warm-up.
2. Operate engine at less-than-normal load and speed until engine reaches normal operating temperatures.

Cold Weather Engine Start Up

CAUTION:  The improper use of starting aids (starting fluid) can cause severe engine damage and personal injury. Read and understand the engine manufacturer's manual before attempting to start the engine using cold weather starting aids. Engines equipped with glow plugs and some turbocharged engines will be damaged when using starting fluid for starting purposes.

See the engine manufacturer's manual for information on cold weather starting, starting aids, and other engine operation information.

Cold Weather Engine Warm Up (40°F or below)

NOTE: If hydraulic oil is cold, hydraulic components move slowly. Do not attempt machine operations until hydraulic components operate normally.

1. Run engine at 1/3 throttle for five minutes.
2. Operate all hydraulic components before moving machine.

Using Booster Battery - 12 Volt System

1. Make sure the FORWARD/REVERSE switch (Figure 3-1, item 19) is in neutral before using booster battery to start the engine.

CAUTION:  A charging battery produces explosive gases. Keep flames and sparks away from battery area. Charge battery in a well ventilated area.

NOTE: The electrical system is 12 volts with negative (-) ground. Use only 12-volt booster battery.

CAUTION:  Improperly connected jumper cables can produce sparks and explosion. Make sure negative terminals are connected and positive terminals are connected. Never connect negative terminal to a positive terminal. Do not allow vehicles to touch.

2. Connect the positive (red) jumper cable to the positive battery post on the booster battery and machine battery.
3. Connect the negative jumper cable to the booster battery negative post and a good ground (frame, bracket or support) away from the battery and moving engine components.
4. After starting, remain at the control pedestal and have a helper remove the jumper cables from the machine.

STOPPING THE ENGINE

1. Park machine on a level surface.
2. Place FORWARD/REVERSE switch in the neutral position.
3. Lower all equipment to ground level.
4. Run engine at 1/2 speed without load for 3 to 5 minutes.
5. Place throttle in low idle.
6. Place ignition switch in the OFF position and remove key.

EMERGENCY STOPPING

1. In an emergency, push the red EMERGENCY STOP button (Figure 3-1, item 13, or Figure 3-3, item 3).
2. After emergency is cleared, pull the EMERGENCY STOP button to reset.
3. Refer to ENGINE START UP on the previous page for control settings before re-starting the engine and resuming operations.

Section 3 OPERATION



ADJUSTING ENGINE FOR HIGH ELEVATION

ATTENTION: Do not change engine settings to compensate for elevation. An authorized service dealer must service the injection pump.



Refer to the engine manufacturer's manual for information on engine specifications and settings. See the local authorized dealer for engine settings and modifications.

DRIVING THE MACHINE

Before operating on public roads, check state and local laws that may apply to construction equipment. Additional lights, mirrors, SMV emblems, or reflectors may be required.

MANUAL DIRECTIONAL CONTROL

NOTE: The Curber can be manually operated in the forward and reverse directions to align the machine for operation, or to transport the machine on and off a trailer. Refer to *Operating the Machine*, in this section, for information on machine setup and automatic operation.

The LBC-24W Curber is equipped with forward/reverse variable speed, hydrostatic, hydraulic motors. The three hydraulic motors operate at the same time.

A control knob (Figure 3-1, item 18) controls the hydraulic motor torque and speed. A drive switch (Figure 3-1, item 19) controls hydraulic flow and direction of flow to the motors.

1. To move forward, push the FORWARD/REVERSE switch in the FORWARD position.
2. Advance control knob to walking speed (RPM).
3. Place the FORWARD/REVERSE switch in the REVERSE position to move the machine in reverse.

TRAVEL SPEEDS

Increasing throttle (Figure 3-1, item 14) and increasing variable drive (Figure 3-1, item 18) will increase travel speeds.

THROTTLE CONTROL

The throttle control is mounted on the Main Control Panel. It is used to control the engine speed (RPM).

Push the switch up in momentary adjustments to increase engine speed. Push the switch down to decrease engine speed. Holding the switch in position will increase or decrease engine speed to its maximum/minimum.

BRAKING

Braking on the LBC-24W Curber occurs when automatic operation is released by placing the Top-Con Power switch (Figure 3-1, item 5) in the OFF position and reducing engine speed using the throttle control.

PARKING THE MACHINE

Before leaving the machine, perform the following procedures:

1. Park machine on a level surface.
2. Return FORWARD/REVERSE switch to neutral position.
3. Lower all equipment to ground level.
4. Place variable speed control (Figure 3-1, item 18) in the low position.
5. Idle engine for 3 - 5 minutes at ½ speed (RPM).
6. Place throttle control at low idle.
7. Place ignition switch in the OFF position and remove key.
8. Block the wheels or use wheel chocks.

SURFACE PREPARATION

The curbing surface must be graded to specifications before attempting to operate the LBC-24W Curber on the curb installation surface. The leveling blade and auger on the Curber act as devices for removing small imperfections in the curbing surface for machine operations.

The curbing surface and boundaries should be marked and a string line installed for Curber setup and operation.

MACHINE PREPARATION

NOTE: See Section 3, Operating Controls, Indicators, and Gauges, earlier in this section, for location and illustration of controls and functions.

This manual does not attempt to teach actual curbing operations. A qualified operator trained in all types of curbing operation should do curbing. The operator must thoroughly understand the mechanical characteristics of the Curber and varying elements and terrain for safe operation. The operator must also understand concrete consistency, slump, grade, line setting, finishing and application.

MOLD INSTALLATION

WARNING: Do not work underneath a raised hopper without engaging the safety support (Figure 3-5). During installation of molds stay clear of the hopper. Serious injury can occur if the hopper falls while service is being performed underneath. To engage the safety support, remove the cotter pin from the back of the locking pin. Raise the inner part of the support and line up the holes with those on the outer section. Insert locking pin and attach the cotter pin.



The various molds should be installed and machine prepared before aligning machine for operation. The mold can be removed and replaced as follows.

1. Select the appropriate mold for curb installation.
2. Using the HOPPER LIFT switch (Figure 3-1, item 30) lift the hopper high enough for mold installation.
3. Make sure all wiring harnesses and auxiliary port hydraulic hoses are moved out of the mold installation area.

ATTENTION: If the hopper vibrators are installed during mold installation, be careful not to damage the vibrator during mold installation.

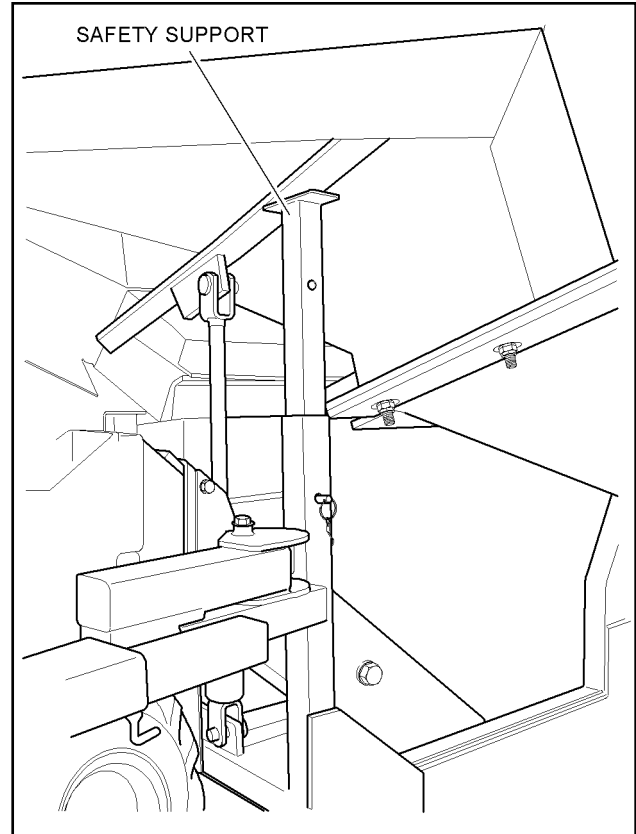

FIGURE 3-5. SAFETY SUPPORT

4. Position the mold underneath the hopper and slowly lower the hopper while positioning the mold for installation of the mounting bolts and nuts. Secure the mold to the hopper with mounting bolts and nuts.

INITIAL SETUP

The Curber uses three sensors during automatic operation to guide the computer in curb installation.

The sensor arms can be adjusted by releasing the adjustment lock (Figure 3-6) and moving the arm in or out. After positioning tighten adjustment lock.

The machine should be aligned with the string line and the sensors adjusted with an equal amount of travel in both directions.

Section 3 OPERATION

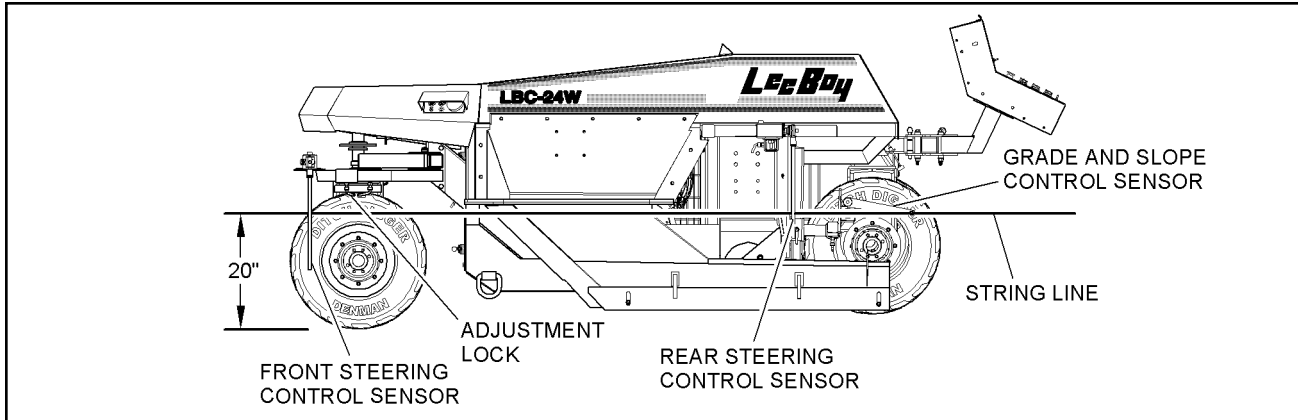

FIGURE 3-6. CURBING SENSORS

USING THE TOP-CON SYSTEM

BASIC OPERATION

Turn the Control Box on by placing the Top-Con Power switch (Figure 3-7 and Figure 3-1, item 5) in the ON position and turn the key to start the engine. The standard control screen (Figure 3-8) allows the operator to select either Control, or Setup. The adjustments and settings will appear as set the last time the control box was shut off. To work in the

modes (Figure 3-8), press the function button directly above the desired display.

CONTROL MODE

The control screen allows the operator to control the machine using dual elevation or a combination of elevation and slope control. The screen is split into two separate displays (Figure 3-9). The left display indicates elevation, the right screen indicates either elevation or slope, as shown on the display.

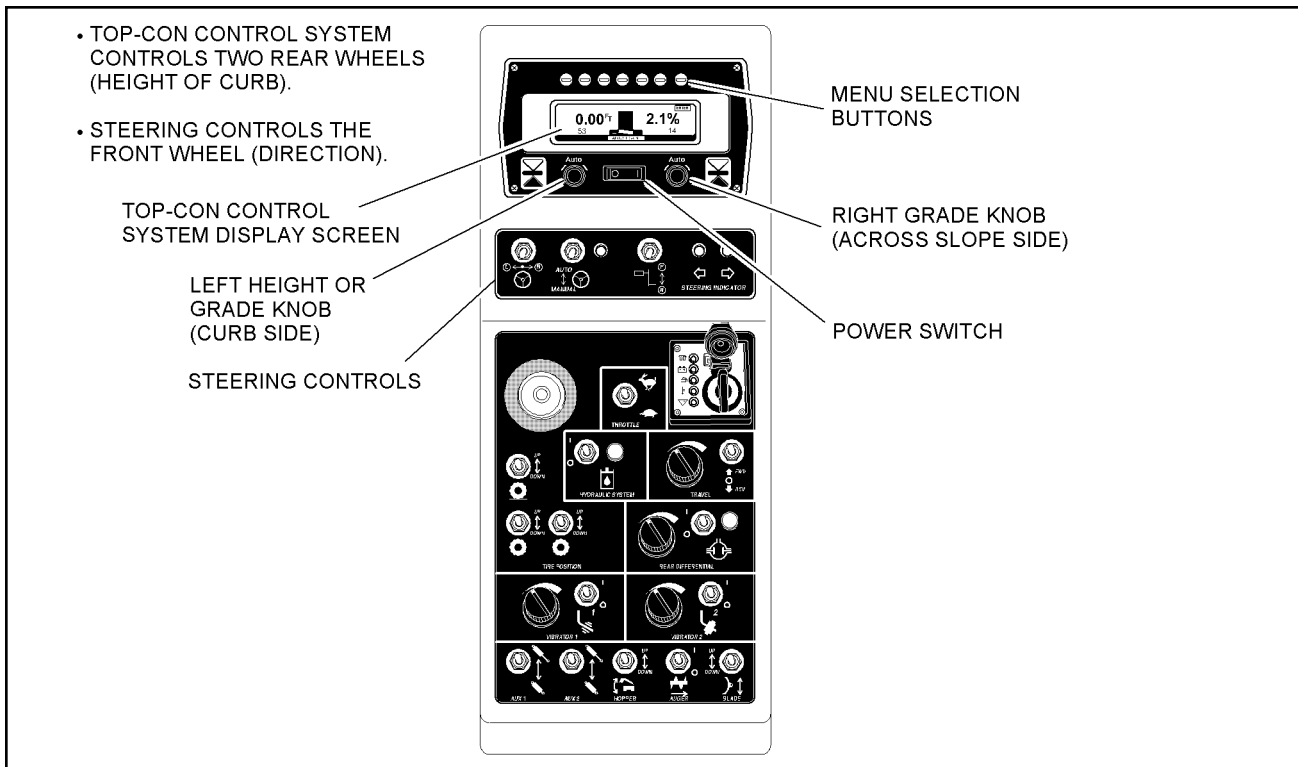

FIGURE 3-7. CONTROL PANEL

In the center of the display (Figure 3-10) is a symbol of the blade showing elevation and slope. The symbol indicates the direction of slope. On either side of the blade symbol is a symbol indicating left side (slope) control or right side (tilt) control.

Menu Selection Soft Keys (see Figure 3-9)

MENU Key - Selecting MENU changes the display back to the Main Control selection screen.

SET Key - SET has two functions. The first function changes the reference number on the display to a desired value. Using SET will not change the grade or elevation, only the reference number on the display. The desired setting can be set by turning the left grade knob.

The second function is used to calibrate the slope sensor. The operator starts by setting the machine on a known grade slope and using the right grade knob to adjust the slope display to the known slope setting. After making the changes to the settings, select ENTER. If EXIT is selected the settings will not be saved.

AUTO Key - There are two AUTO keys, a left key and a right key. When the appropriate key is selected the red arrow symbol directly above the grade knob will begin to flash. This indicates that the system's AUTO modes are armed and can be activated by switching the single remote switch on, giving the operator a single switch to control both left and right grades.

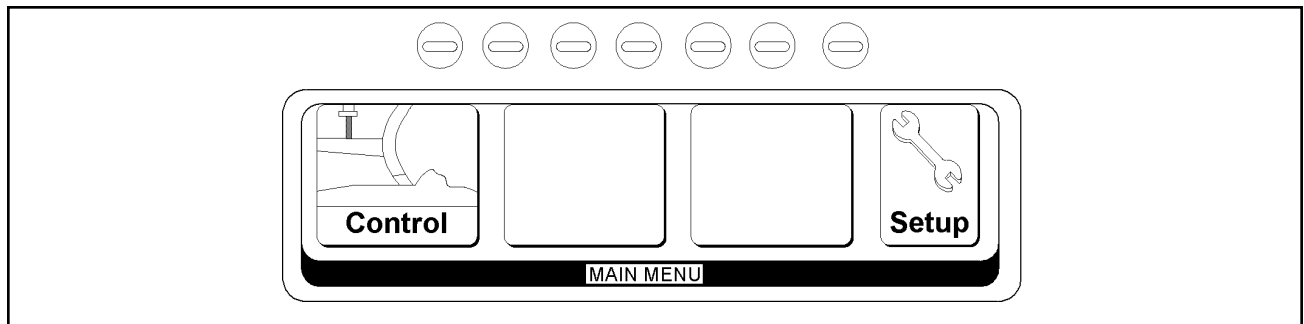

FIGURE 3-8. BASIC OPERATION

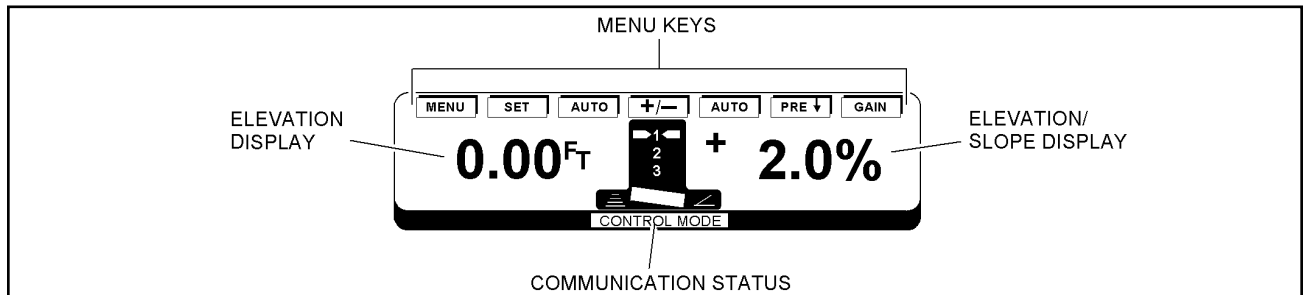

FIGURE 3-9. CONTROL MODE

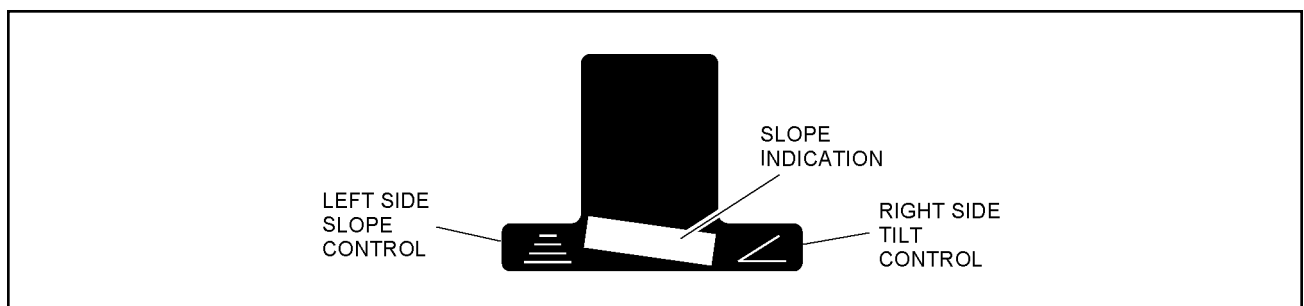

FIGURE 3-10. ELEVATION/SLOPE INDICATION

Section 3 OPERATION



+/- Key - The +/- key allows the operator to change direction of slope with a single push of a button.

GAIN Key - Selecting the GAIN key allows the operator to adjust left or right control valves while under full automatic control. The right knob makes adjustments to the right slope valve and the left knob makes adjustments to the left elevation valve. The number displayed below the elevation or slope display number is the gain setting. In Figure 3-12 the elevation gain is 53 and the slope gain is 14.

SETUP MODE

The SETUP menu (Figure 3-13) is where machine setup is performed. The manufacturer has set the maximum voltage setting for the largest valve being used in the Top-Con system.

Use the right grade knob to move through the menu. Press ENTER to make a menu selection.

Adjust Valve Offsets

This sets the minimum signal (voltage) required to operate the hydraulic valves. Start by raising the

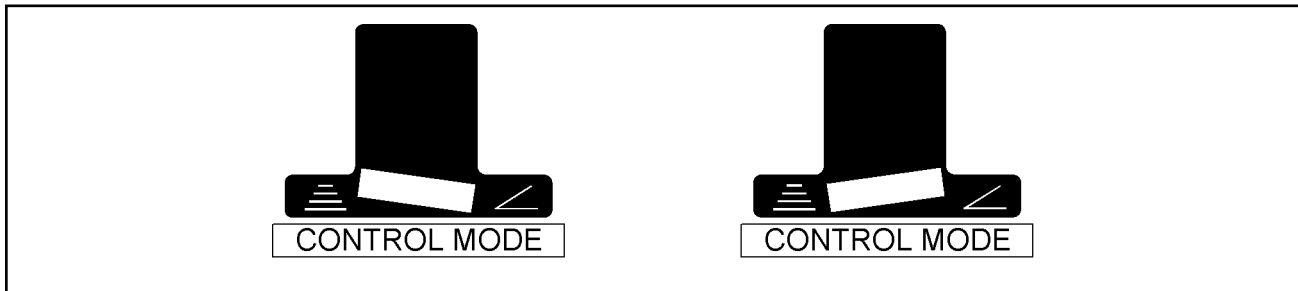

FIGURE 3-11. SLOPE DIRECTION

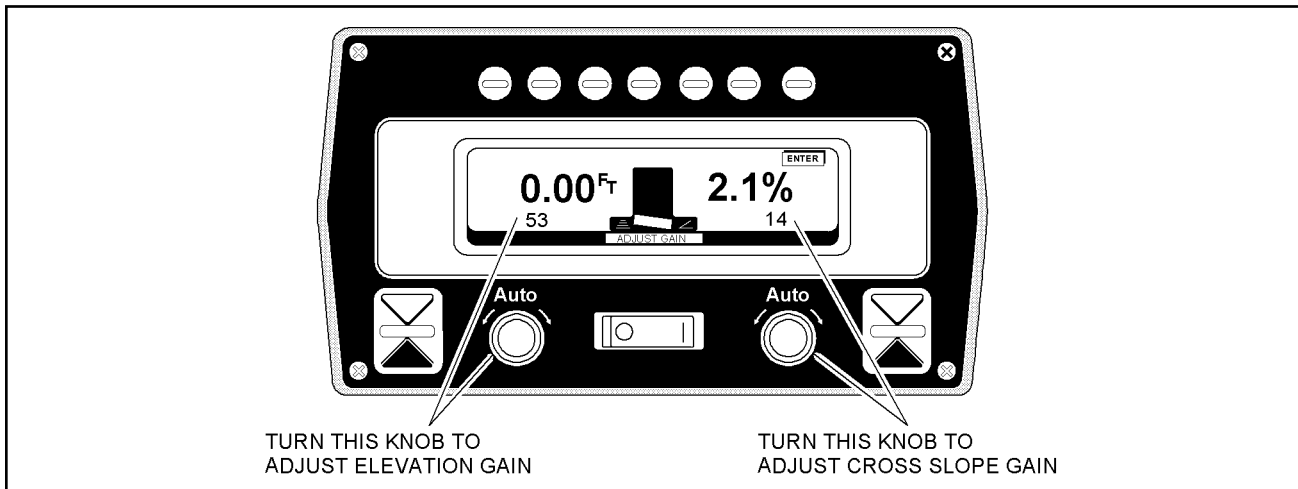

FIGURE 3-12. ELEVATION AND SLOPE GAIN

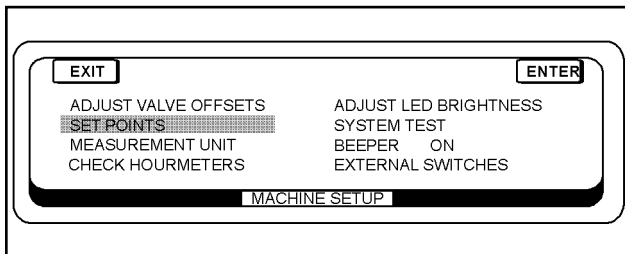

FIGURE 3-13. SET-UP MENU

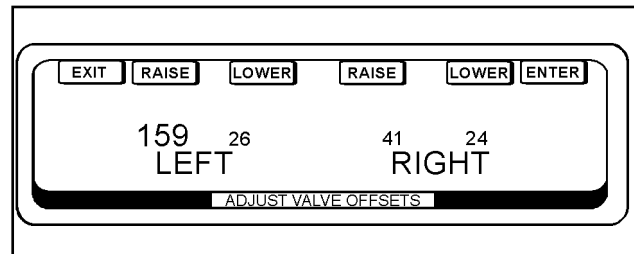

FIGURE 3-14. ADJUST VALVE OFF-SET

blade off the ground (Figure 3-1, item 32). With the engine at full throttle, select either the RAISE or LOWER key (Figure 3-14) for the left elevation valve. Using the left rotary knob, dial the number to 0. Slowly increase the number until the blade just begins to move.

Set the other signal for the left elevation valve, and the signals for the right elevation valve in the same manner. In Figure 3-14, 159 and 26 represent the voltage being used to raise and lower the left side (grade), while 41 and 24 represent the voltage used to raise and lower the right side (slope or tilt).

Select ENTER to save the changes. Selecting EXIT will not save any changes.

Measurement Units

This menu selection changes the elevation units from feet to meters.

Check Hourmeters

The system has two hourmeters. The system will display both Hours On and Hours Automatic.

Adjust LED Brightness

By following the on-screen directions, the operator can adjust the Back Light as well as the Brightness of the LED screen.

System Test

Any time the operator sees “Comm Error”, they should enter the System Test mode. If a sensor is not functioning, the message following the sensor description will indicate ERROR.

Beeper On/Off

The system has a built-in audible feature that will sound when an elevation reference is lost. The operator can turn the Beeper on or off, using this menu selection.

OPERATING THE MACHINE

1. After the machine is in position and aligned for operation, add or remove mold weights for the type of curb to be installed. Install both weights for curb installation and finishing. Depending on the consistency of the concrete, the operator may choose to remove one weight when performing curb-only installations.

2. Using switches 24 through 27 (Figure 3-1), adjust the speed for the left and right hopper vibrators.
3. Travel speed (Figure 3-1, item 18) and vibrator speeds need to be coordinated. If travel speed is too fast relative to vibrator speed, breaks in the concrete will occur. If travel speed is too slow, the concrete will extrude past the molds and raise the hopper.
4. Place the Master Power switch (Figure 3-1, item 17) in the ON position and turn the key to start the engine.
5. Place the Top-Con Power switch (Figure 3-1, item 5) in the ON position.
6. Enter control function.
7. Set elevation and slope using the Top-Con controls.
8. Turn ON steering computer (Figure 3-1, item 9) and push the steering sensor selector switch (Figure 3-1, item 11) up for straight or down for tight radius.
9. If necessary, engage the leveling blade and auger to remove surface imperfections during curbing operation.
10. Position concrete supply vehicle and test concrete consistency and slump.

CAUTION: Beware of workers and other personnel in the area. In case of emergency press the EMERGENCY STOP button (Figure 3-1, item 13, or Figure 3-3, item 3). Pull the button up to resume operation.



11. Begin curbing operation while making minute adjustments to height, steering, elevation gain, and elevation/slope gain using the Top-Con control console.
12. After curbing operation is complete, place Master Power switch (Figure 3-1, item 17) in the OFF position and turn the ignition key OFF.
13. Thoroughly clean the Curber after curbing operations and transport to storage facility.

Section 3 OPERATION



TRANSPORTING THE LBC-24W CURBER

When transporting the machine on a flat bed vehicle, the vehicle must be capable of carrying the machine safely in all driving situations.

1. Clean the machine using a pressure washer. Remove all loose gravel, mud or debris from wheels, frame, and molds.
2. Make sure the combined height of the truck, trailer and loaded Curber meet height restrictions for the local area, including bridges, overpasses, and overhead obstructions.
3. Park the transport vehicle on a level surface and set the park brake.
4. Install chocks or blocks against truck and trailer wheels.
5. Use a ramp or loading dock. Make sure the ramp weight capacity will support the machine and has a low angle of rise to the trailer bed.
6. Load the machine on the trailer bed by driving straight on, centered on the trailer. The Curber centerline must be over the centerline of the trailer.
7. Block the Curber wheels in both directions to prevent rolling.

CAUTION:



Secure the machine with chains, cables, and binders of sufficient strength to prevent the machine from moving or breaking loose during travel.

ATTENTION:



Fasten chains or cables to machine frame. Do not place chains or cables over or against hydraulic lines, hoses or electrical harnesses.

8. Secure the machine to the trailer using the tie-downs located at three places, one on either side at the front and one between the rear wheels of the machine frame. See Figure 3-15.
9. Idle the engine at 1/2 speed (RPM) for 3 to 5 minutes.
10. Place engine throttle at slow idle.
11. Place ignition switch in the OFF position and remove the key.

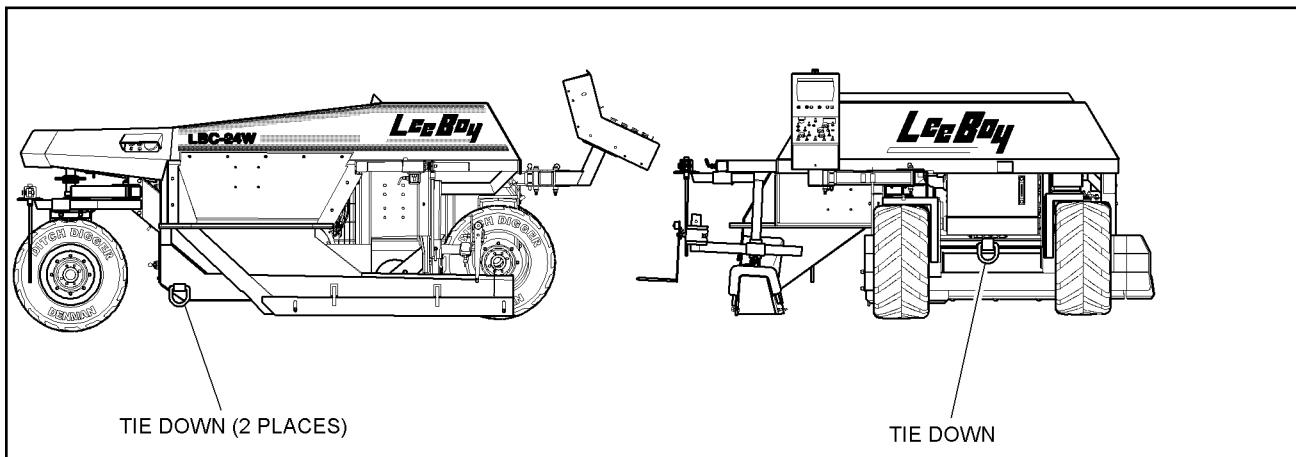

FIGURE 3-15. TIE DOWN POINTS

TABLE OF CONTENTS

	Page
GENERAL INFORMATION	4-3
ROUTINE MAINTENANCE	4-3
GENERAL INFORMATION	4-3
MACHINE LUBRICATION	4-3
TABLE 4-1. MAINTENANCE INTERVAL CHART	4-4
TABLE 4-2. TORQUE SPECIFICATIONS FOR STANDARD INCH FASTENERS	4-5
TABLE 4-3. TORQUE SPECIFICATIONS FOR METRIC FASTENERS	4-6
MAINTENANCE SCHEDULE	4-7
GENERAL INFORMATION	4-7
PREPARING THE MACHINE FOR MAINTENANCE	4-7
CHECKS AND ADJUSTMENTS	4-7
CHECKING OIL LINES AND FITTINGS	4-7
CHECKING AIR INTAKE HOSES	4-7
CHECKING AND ADJUSTING THE DRIVE BELT	4-7
ENGINE MAINTENANCE	4-8
GENERAL INFORMATION	4-8
CHECKING ENGINE SPEED	4-8
FUEL SYSTEM	4-8
CHANGING ENGINE FUEL FILTER	4-8
CLEANING AND CHECKING FUEL FILLER CAP	4-9
CHECKING ENGINE AIR CLEANER ASSEMBLY	4-9
REPLACING ENGINE AIR FILTER ELEMENTS	4-9
RADIATOR AND COOLANT SYSTEM	4-10
CHECKING RADIATOR AND COOLANT LEVEL	4-10
DRAINING, FLUSHING, AND FILLING ENGINE COOLANT SYSTEM	4-10
BATTERY MAINTENANCE	4-11
CLEAN AND TIGHTEN BATTERY TERMINALS	4-12
CHECKING BATTERY ELECTROLYTE LEVEL	4-12
ELECTRICAL SYSTEM	4-12
FUSES	4-12
TABLE 4-4. BLADE TYPE FUSE CODES	4-13
STEERING CALIBRATION	4-14
HYDRAULIC SYSTEM	4-14
CHECKING HYDRAULIC OIL LEVEL	4-14
CHANGING LOW-PRESSURE HYDRAULIC FILTER	4-14
CHANGING HIGH-PRESSURE HYDRAULIC FILTER	4-15
CHECKING AND CLEANING HYDRAULIC RESERVOIR FILLER CAP	4-16
DRAINING, FLUSHING, AND FILLING HYDRAULIC OIL RESERVOIR	4-16
TIRES AND WHEELS	4-16
CHANGING TIRES	4-16
TORQUE HUBS	4-16

Section 4 MAINTENANCE



TABLE OF CONTENTS (CONTINUED)

	Page
STORAGE	4-17
PREPARING THE MACHINE FOR LONG-TERM STORAGE	4-17
PERIODIC MAINTENANCE DURING STORAGE	4-17
REMOVING THE MACHINE FROM STORAGE	4-18
DECAL INSTALLATION	4-18
TROUBLESHOOTING	4-19
GENERAL INFORMATION	4-19
TROUBLESHOOTING CHARTS	4-19
SCHEMATICS	4-31
MAIN DIAGRAM, POSITIVE FEEDS/ENGINE	4-31
FRONT WHEEL HEIGHT, AUXILIARY 1 & 2, AUGER LIFT, AND HOPPER LIFT	4-32
PLUS 1 CONTROLS	4-33
TOPCON CONTROLS	4-34
HYDRAULIC SCHEMATIC	4-35

GENERAL INFORMATION

This section gives the necessary procedures for routine and general maintenance on the LBC-24W Curber. Before starting any Maintenance program on the machine, it is important to READ, UNDERSTAND, and FOLLOW all Maintenance instructions, Danger, Warning, and Caution messages in this section, as well as all Safety information contained in Section 1 of this manual.

DANGER: Failure to observe the Maintenance instructions, Danger, Warning, and Caution messages in this manual can cause serious injury or death.



NOTE: By following a careful service and maintenance program for your machine, you will insure many years of trouble free operation.

PROPERLY MAINTAINED EQUIPMENT IS SAFE EQUIPMENT! The user of this product is responsible for inspecting the machine daily, and for having parts replaced or repaired when continued use would cause damage or excessive wear to other parts. General daily inspection of the machine should include inspection for missing guards, loose bolts, fluid leaks, worn or damaged hoses and debris or dirt accumulations which could cause a potential service or safety problem.

ROUTINE MAINTENANCE

GENERAL INFORMATION

Maintenance must be a planned program that includes periodic machine inspection and lubrication procedures.

The maintenance program must be done based on the machine's "Operating Hours", recorded on the hour meter, or on a "Periodic Schedule", which is done at daily, weekly, monthly, or yearly intervals.

ATTENTION: When performing routine maintenance such as 50, 100, 250, 500, or 1000 hours, always include previous routine maintenance hours to the higher hourly schedule.



Table 4-1, Maintenance Interval Chart, lists recommended maintenance procedures and time intervals between machine maintenance inspections and lubrication procedures. Tables 4-2 and 4-3 list recommended torque values for fittings and fasteners commonly used on this machine.

MACHINE LUBRICATION

Proper lubrication is necessary to maintain the machine at top efficiency. Refer to the lubrication information in Table 4-1, Maintenance Interval Chart. All lubrication points are shown in Figure 4-1.

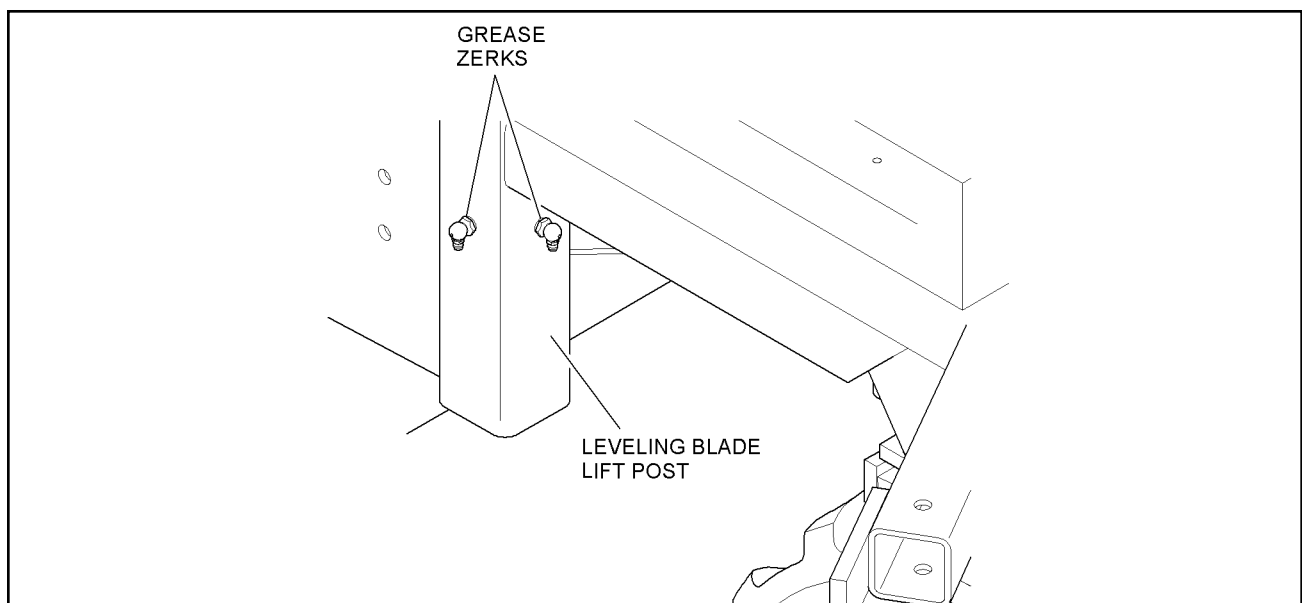

FIGURE 4-1. LUBRICATION POINTS

Section 4 MAINTENANCE



TABLE 4-1. MAINTENANCE INTERVAL CHART

8 HOURS or DAILY		
Engine Oil Level	Check	See engine manufacturer's manual
Engine Coolant	Check	50/50 Antifreeze
Engine Air Filter (Primary)	Check	986775-05
Engine Air Filter (Secondary)	Check	986775-06
Engine Fuel Filter	Check	986775-07
Hydraulic Oil	Check	AW32
Hydraulic Filter (Low Pressure)	Check	983835-01
Hydraulic Filter (High Pressure)	Check	983976-01
FIRST 50 HOURS		
Torque Hubs	Check	50W Gear Lubricant
Engine Oil	Replace	See engine manufacturer's manual
Engine Oil Filter	Replace	986775-04
50 HOURS or WEEKLY		
Engine Air Filter (Primary)	Check	986775-05
Engine Air Filter (Secondary)	Check	986775-06
Levelling Blade Zerk	Lubricate	Shell Avania EP Grease
FIRST 100 HOURS		
Hydraulic Oil	Replace	AW32
Hydraulic Filter (Low Pressure)	Replace	983835-01
Hydraulic Filter (High Pressure)	Replace	983976-01
Hydraulic Strainer	Clean	33148
100 HOURS or MONTHLY		
Engine Belt	Check	986775-15
Engine Air Filter (Primary)	Replace	986775-05
Steering Pivots	Check	Multi-Service Grease
250 HOURS or QUARTERLY		
Engine Air Filter (Secondary)	Replace	986775-06
Engine Oil	Replace	See engine manufacturer's manual
Engine Oil Filter	Replace	986775-04
500 HOURS or SEMI-ANNUALLY		
Engine Fuel Filter	Replace	986775-07
Engine Coolant	Replace	50/50 Antifreeze
Hydraulic Oil	Replace	AW32
Hydraulic Filter (Low Pressure)	Replace	983835-01
Hydraulic Filter (High Pressure)	Replace	983976-01
Hydraulic Strainer	Replace	33148
Steering Bearings	Re-Pack	Wheel Bearing Grease
Torque Hubs	Check and Fill	50W Gear Lubricant

TABLE 4-2. TORQUE SPECIFICATIONS FOR STANDARD INCH FASTENERS

The following table lists torque values for standard fasteners and is intended as a guide for average application involving typical stresses and machined surfaces. Values are based on physical limitations of clean, plated and lubricated hardware. Check tightness of bolts periodically, using this table as a guide. When using locking fasteners, increase torque values by 5%.

CAUTION: Always replace original equipment with hardware of equal grade. When an individual torque value is specified, it should be followed instead of values given in this table.



SIZE	THREAD	CAP SCREWS: SAE GRADE 5				CAP SCREWS: SAE GRADE 8			
		TORQUE FT. LBS.		TORQUE N.m		TORQUE FT. LBS.		TORQUE N.m	
		Dry	Lubed	Dry	Lubed	Dry	Lubed	Dry	Lubed
1/4	20 UNC	8	6	11	9	12	9	16	12
	28 UNF	10	7	13	10	14	10	19	14
5/16	18 UNC	17	13	24	18	25	18	33	25
	24 UNF	19	14	26	20	27	20	37	28
3/8	16 UNC	31	23	42	31	44	33	59	44
	24 UNF	35	26	47	36	49	37	67	50
7/16	14 UNC	49	37	67	50	70	52	95	71
	20 UNF	55	41	75	56	78	58	105	79
1/2	13 UNC	75	57	100	77	105	80	145	110
	20 UNF	85	64	115	86	120	90	165	120
9/16	12 UNC	110	82	145	110	155	115	210	155
	18 UNF	120	91	165	125	170	130	230	175
5/8	11 UNC	150	115	205	155	210	160	285	215
	18 UNF	170	130	230	175	240	180	325	245
3/4	10 UNC	265	200	360	270	375	280	510	380
	16 UNF	295	225	405	300	420	315	570	425
7/8	9 UNC	430	320	580	435	605	455	820	615
	14 UNF	475	355	640	480	670	500	905	680
1	8 UNC	645	485	875	655	910	680	1230	925
	14 NF	720	540	980	735	1020	765	1380	1040
1-1/8	7 UNC	795	595	1080	805	1290	965	1750	1310
	12 UNF	890	670	1210	905	1440	1080	1960	1470
1-1/4	7 UNC	1120	840	1520	1140	1820	1360	2460	1850
	12 UNF	1240	930	1680	1260	2010	1500	2730	2050
1-3/8	6 UNC	1470	1100	1990	1490	2380	1780	3230	2420
	12 UNF	1670	1250	2270	1700	2710	2040	3680	2760
1-1/2	6 UNC	1950	1460	2640	1980	3160	2370	4290	3210
	12 UNF	2190	1650	2970	2230	3560	2670	4820	3620

Section 4 MAINTENANCE



TABLE 4-3. TORQUE SPECIFICATIONS FOR METRIC FASTENERS

The following table lists torque values for metric fasteners and is intended as a guide for average application involving typical stresses and machined surfaces. Values are based on physical limitations of clean, plated and lubricated hardware. Check tightness of bolts periodically, using this table as a guide. When using locking fasteners, increase torque values by 5%.

CAUTION: Always replace original equipment with hardware of equal grade. When an individual torque value is specified, it should be followed instead of values given in this table.



NOMINAL SIZE & PITCH	CLASS 8.8 (GRADE 5 EQUIVALENT)				CLASS 10.9 (GRADE 8 EQUIVALENT)			
	TORQUE FT. LBS.		TORQUE N.m.		TORQUE FT. LBS		TORQUE N.m	
	Dry	Lubed	Dry	Lubed	Dry	Lubed	Dry	Lubed
M4 x 0.7	2.27	1.70	3.07	2.30	2.27	2.31	4.17	3.13
M5 x 0.8	4.58	3.43	6.20	4.65	6.22	4.67	8.43	6.33
M6 x 1	7.75	5.83	10.5	7.90	10.60	7.97	14.3	10.8
M8 x 1.25	18.89	14.17	25.6	19.2	18.95	19.26	34.8	26.1
M10 x 1.25	39.11	29.52	53.0	40.1	53.87	40.59	73.0	55.0
M12 x 1.75	64.94	48.71	88.0	66.0	88.56	66.42	120.0	90.0
M14 x 2	103.32	77.49	140.0	105.0	140.22	107.01	190.0	145.0
M16 x 2	162.36	121.77	220.0	165.0	221.40	166.05	300.0	225.0
M20 x 2.5	317.34	236.16	430.0	320.0	428.04	321.03	580.0	435.0
M24 x 3	516.12	409.59	740.0	555.0	754.38	557.19	1010.0	755.0
M27 x 3	797.04	597.78	1080.0	810.0	1084.86	811.80	1470.0	1100.0
M30 x 3.5	1084.86	811.80	1470.0	1100.0	1476.00	1107.00	2000.0	1500.0

MAINTENANCE SCHEDULE

GENERAL INFORMATION

Preventive maintenance on the LBC-24W Curber will provide years of trouble-free operation. Adjustments can be performed in the field with ordinary hand tools. Engine preventive maintenance, other than oil, air, and fuel filter changes, is not covered in this section. Refer to the engine manufacturer's manual for engine service information.

NOTE: Changing oil and cleaning the machine should only be done in an area designed to contain the oil and chemicals involved in any maintenance requirement. Discard these by-products in accordance with environmental regulations.

CAUTION: Do not substitute fasteners of any kind unless the fasteners are equal in size and grade to original equipment. See Tables 4-5 and 4-6 for torque specifications.



ATTENTION: When performing routine maintenance such as 50, 100, 250, 500, or 1000 hours, always include previous routine maintenance hours to the higher hourly schedule.



PREPARING THE MACHINE FOR MAINTENANCE

When performing maintenance, perform the following steps before leaving the operator's position, unless the maintenance procedure instructs otherwise.

1. Park the machine on a flat even surface.
2. Lower all attachments to ground level.
3. Place transmission in neutral.
4. Run engine at 1/2 speed (RPM) without load for 3 to 5 minutes.
5. Reduce engine speed (RPM) to slow idle.
6. Place ignition switch in the OFF position.

WARNING: If maintenance must be performed with engine running, do not leave machine unattended.



CHECKS AND ADJUSTMENTS

1. Check for loose, damaged, missing or corroded parts. Repair or replace as required.
2. Check for damaged, loose, or missing decals. Replace decals as required.

CHECKING OIL LINES AND FITTINGS

1. Refer to PREPARING MACHINE FOR MAINTENANCE and park machine.
2. Check the machine for indications of oil leakage around oil lines, hoses, and fittings.
3. Tighten fittings as necessary. Replace hoses and fittings as needed.

CHECKING AIR INTAKE HOSES

Check air intake hoses from the engine to the air cleaner assembly. Check for cracked, dry rotted, loose, worn, or damaged hoses, tubes, and clamps. Tighten, repair, or replace parts as needed.

CHECKING AND ADJUSTING THE DRIVE BELT

NOTE: Refer to the engine manufacturer's manual for additional information on checking and adjusting drive belts.

1. Inspect the belt frequently and replace the belt if stretched, cracked, or dry rotted.
2. Check the belt tension (Figure 4-2). See the engine manufacturer's manual for tension specifications.
3. If belt is not within specifications, replace the belt.

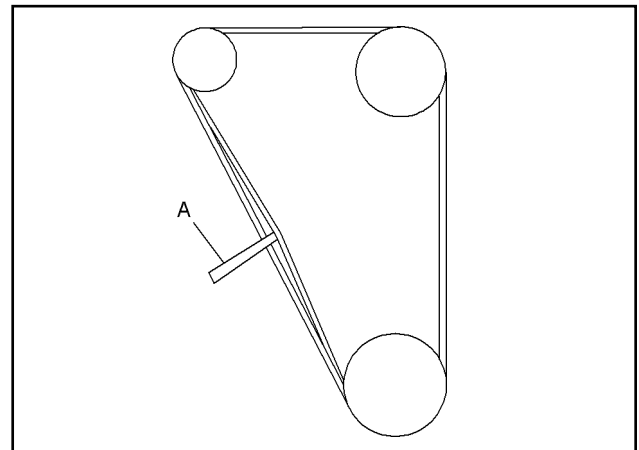

FIGURE 4-2. FAN BELT ADJUSTMENT

Section 4 MAINTENANCE



ENGINE MAINTENANCE

GENERAL INFORMATION

Refer to the engine manufacturer's manual for additional information on engine service. Use manufacturer's recommendations for engine oil and filter replacement.

The engine lubrication oil must be kept at a level above the "ADD" mark, but not above the "FULL" mark, on the engine lubrication oil dipstick.

WARNING: Stop the engine before checking the engine lubrication oil level. With the engine running, hot oil can be thrown causing serious injury.



To accurately check the engine lubrication oil level, park the machine in a level position and stop the engine. Clean the area around the engine lubrication oil dipstick before removing the dipstick from the engine. Wait five minutes, after engine shutdown, before removing the dipstick from the engine and checking the oil level. Remove the filler cap and add oil as necessary.

NOTE: The above procedure will allow the oil to return to the oil pan and help remove the possibility of filling the engine with too much lubrication oil.

WARNING: Stop the engine before checking the engine lubrication oil level. With the engine running, hot oil can be thrown causing serious injury.



CHECKING ENGINE SPEED

Refer to the engine manufacturer's manual for additional information on engine service. Use manufacturer's recommendations for engine speed and adjustments.

FUEL SYSTEM

Keep the fuel tank full to prevent condensation from forming. Fill the fuel tank at the end of each day.

WARNING: Diesel fuel is highly explosive. Do not expose fuel to sparks or flames. Do not smoke while performing maintenance on the engine fuel system.



CHANGING ENGINE FUEL FILTER

Refer to the engine manufacturer's manual for additional information on engine service. Use manufacturer's recommendations for engine fuel filter replacement and bleeding the fuel system.

1. Refer to PREPARING MACHINE FOR MAINTENANCE and park the machine.
2. Allow the engine to cool completely.
3. Locate the fuel filter (Figure 4-3) located on the right side of the Curber.

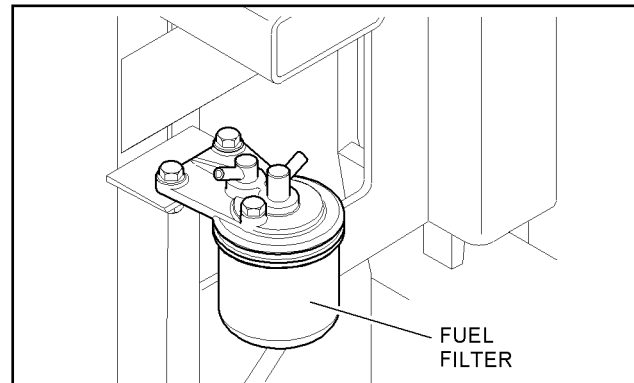

FIGURE 4-3. FUEL FILTER

WARNING: Wear eye protection and chemical resistant gloves when using solvent for cleaning purposes. Some solvents can cause skin irritation and eye damage.



WARNING: Wear eye protection when using compressed air for drying or cleaning components. Never point the nozzle at another individual. Use a safety reduction valve to reduce air pressure to a safe level. Compressed air can cause serious personal injury if misused.



4. Using solvent, thoroughly clean the area surrounding the fuel filter. Dry with compressed air.
5. Turn the fuel filter counterclockwise to remove. Clean the mounting surface and remove any loose filter seals in the filter head-mounting surface.
6. Fill the replacement fuel filters with clean diesel fuel.
7. Lightly lubricate the secondary filter seal with clean engine oil. Turn the filter clockwise until seal contacts filter head. Tighten filter 1/2 to 3/4 additional turn.
8. Using the priming plunger and instructions in the engine manufacturer's manual, fill the filters with fuel and bleed the fuel system.
9. Start engine and check for leaks. Tighten or replace filter as necessary.

CLEANING AND CHECKING FUEL FILLER CAP

WARNING: Wear eye protection and chemical resistant gloves when using solvent for cleaning purposes. Some solvents can cause skin irritation and eye damage.



WARNING: Wear eye protection when using compressed air for drying or cleaning components. Never point the nozzle at another individual. Use a safety reduction valve to reduce air pressure to a safe level. Compressed air can cause serious personal injury if misused.



1. Remove filler cap and inspect for damage. Check cap for dirt and clogging.
2. Using solvent, clean cap thoroughly and dry with compressed air.
3. Check cap for free air flow. Replace if necessary.
4. Install cap.

CHECKING ENGINE AIR CLEANER ASSEMBLY

ATTENTION: Do not open the air cleaner assembly unless the air filter restriction gauge indicates an air filter restriction, or engine operation indicates possible air filter restriction.



Check the air cleaner for restriction. If necessary, replace the air filter element.

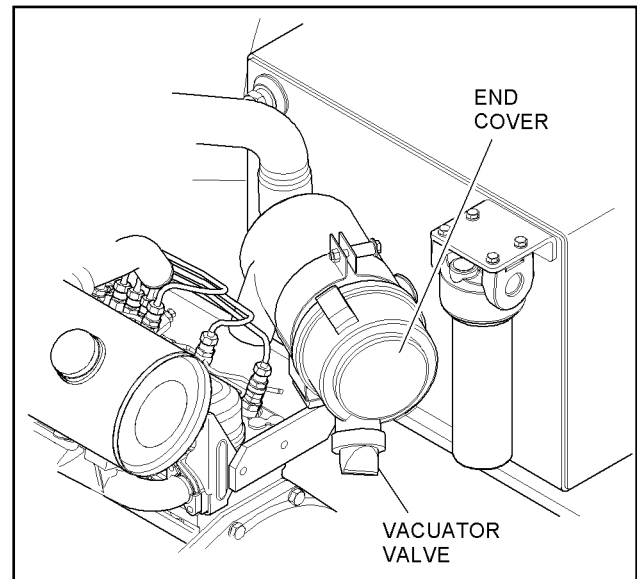

FIGURE 4-4. AIR CLEANER ASSEMBLY

REPLACING ENGINE AIR FILTER ELEMENTS

1. Refer to PREPARING MACHINE FOR MAINTENANCE and park machine.
2. Thoroughly clean air cleaner assembly.
3. Remove the air cleaner end cover by releasing two spring clips.
4. Remove the filter element (Figure 4-4).
5. Clean the air cleaner housing thoroughly. Dry using lint-free cloths.
6. Inspect hose clamps and tighten as necessary.
7. Install filter element.
8. Pinch the vacuator valve together and remove dirt from the valve.
9. Install end cover and secure with spring clips. Make sure vacuator valve is located on the bottom of the end cover after installation.

Section 4

MAINTENANCE



RADIATOR AND COOLANT SYSTEM

CHECKING RADIATOR AND COOLANT LEVEL

ATTENTION: Check the coolant freeze protection level before the start of cold weather. Check with the local authorized dealer for information of freeze protection.



CAUTION: Hot engine coolant can cause serious personal injury. Shut off engine. Do not remove radiator filler cap until it is cool enough to touch with bare hands. Slowly loosen filler cap to first stop to relieve pressure before removing cap completely.



1. Refer to PREPARING MACHINE FOR MAINTENANCE and park the machine.
2. Shut down engine and allow radiator to cool.
3. Open the right hand engine compartment door.
4. Inspect radiator for leaks, dents, cracks and damaged cooling fins. Repair or replace if necessary.
5. Inspect radiator cap for wear and damage. Perform pressure/temperature test if necessary. Replace cap as necessary.
6. Check coolant level in radiator recovery reservoir located on the left side of the radiator.
7. Add coolant to the reservoir as needed to the cold level when the engine is cold and to the hot level when the engine is hot.

DRAINING, FLUSHING, AND FILLING ENGINE COOLANT SYSTEM

See the engine manufacturer's manual for information on draining and replacing engine coolant, coolant levels, and coolant specifications. Use engine manufacturer's recommendations for coolant service.

The Curber is filled with a 50/50 mixture of antifreeze and water at the factory with protection to -34°F (-37°C). Some geographical areas may require special antifreeze or coolant practices. Contact the local authorized dealer for additional information.

CAUTION: Hot engine coolant can cause serious personal injury. Shut off engine. Do not remove radiator filler cap until it is cool enough to touch with bare hands. Slowly loosen filler cap to first stop to relieve pressure before removing cap completely.



1. Refer to PREPARING MACHINE FOR MAINTENANCE and park the machine.
2. Shut down engine and remove ignition key.
3. Allow engine to completely cool before removing radiator cap.

NOTE: Dispose of used coolant properly. Check with local environmental officials for information on disposal procedures. Coolant is extremely poisonous and will cause death if ingested by people or animals.

4. Open radiator petcock and drain coolant into a suitable container. Dispose of coolant properly.
5. Open engine block drain plugs (see engine manufacturer's manual). Drain coolant into a suitable container.
6. Using a good quality coolant system flush product, flush the cooling system using the product directions.
7. Close petcock and engine drains. Fill radiator to full level with 50/50 mixture of antifreeze and water. Contact the local authorized dealer for information on local coolant protection levels.
8. Start engine and run for 15 to 30 minutes to purge air from the engine block. Check coolant recovery tank and fill as necessary.
9. Check recovery tank frequently for proper coolant level.

BATTERY MAINTENANCE

WARNING: Batteries contain sulfuric acid and normally produce explosive gases that can cause serious injury.



Therefore, do not allow flames or sparks to come near the battery. When charging or working near a battery, always shield your face and protect your eyes. In case of acid contact with skin or eyes, flush immediately with water for a minimum of 15 minutes and get prompt medical attention. If acid is swallowed, call a physician immediately.

WARNING: When servicing a battery, always remove the ground cable first followed by the positive cable.



Generally, if the negative cable is grounded during removal, sparks will not occur. If the positive cable is grounded during removal, sparks will occur and could ignite explosive gases.

NOTE: When replacing the battery, discard the old battery properly.

ATTENTION: When servicing the electrical system or welding on the machine, always turn the Master Power switch OFF to disconnect the ground from the battery to prevent damage to the machine's electrical system.



ATTENTION: The electrical system is a negative ground system. Connect the positive (+) cable to the positive (+) post of battery. Connect the ground cable to the negative (-) post of battery. It is advisable to disconnect the negative (-) cable first and connect it last. Reversed polarity can damage the electrical system.



The Curber's electrical system is a 12-volt negative ground system. To access the battery, release the clips on the engine compartment door. Remove the five bolts from the battery panel behind the front steering tire.

Be certain that the terminals and battery posts are thoroughly cleaned and that the battery cable terminals are tight. Dirty or loose connections can create high electrical resistance and permit arcing, which will quickly burn and pit terminals and posts.

Keep the battery clean by washing it off whenever dirt build-up is excessive. If corrosion is present around terminal connections, remove them and wash with ammonia solution or a solution consisting of 1/4 lb. (0.11 kg) baking soda added to one quart of warm water. Make certain the vent caps are tight to prevent solution from entering the cells. After cleaning, pour clean water over the battery and surrounding area to wash the solution away. Check vent cap breather openings to make sure they are open.

Be sure to keep the battery fully charged during cold weather to keep it from freezing. Freezing weather has little affect on a fully charged battery.

When connecting a booster battery, if necessary for cold weather starting, connect one end of the first jumper cable to the positive (+) terminal of the dead battery and the other end to the positive (+) terminal of the booster battery. Connect one end of the second jumper cable to the negative (-) terminal of the booster battery and the other end to the frame of the machine with the dead battery.

The alternator supplies electrical current for charging the battery and ample electrical power to the electronic controls. The built-in regulator in the alternator controls the voltage output. If for any reason the wires must be disconnected from the alternator, mark them so that they can be reconnected properly. Use the following precautions to prevent damage to the alternator and/or regulator:

1. Never polarize an alternator. Never ground any alternator terminals or circuits.
2. Always disconnect the battery before disconnecting or connecting the alternator. Never disconnect the alternator with it operating. Be certain the wiring is properly connected before connecting the battery.
3. Always connect a booster battery in the proper polarity [negative (-) to negative (-) and positive (+) to positive (+)].

Section 4

MAINTENANCE



CLEAN AND TIGHTEN BATTERY TERMINALS

1. Disconnect battery clamps, grounded clamp first.
2. Clean terminals with a stiff brush or battery service tool.
3. Apply grease at the base of the battery terminal to prevent gas from escaping.
4. Install and tighten battery clamps, grounded clamp last.

CHECKING BATTERY ELECTROLYTE LEVEL

ATTENTION: If water is added to battery during freezing weather the battery must be charged immediately to prevent freezing. Charge battery using a battery charger or by running the engine.



1. If using serviceable battery, fill each cell to specified range with distilled water. Do not overfill.
2. Push battery box in and install lock bolt.
3. Check battery charge and charging rate.
4. Shut down engine and remove ignition key.
5. Using a multimeter, check the battery charge by placing the positive (red) multimeter lead on the positive (+) battery terminal and the negative (black) multimeter lead on the grounded (-) battery terminal. With the multimeter set at the 12 VDC setting the battery must show a charge of at least 12 volts. If necessary, charge the battery or perform a load test.
6. Start the engine. With an operator in the operator's position, check the battery charge level, the multimeter should read at least 13.5 volts. If multimeter does not indicate minimum charge, check the machine charging system.

ELECTRICAL SYSTEM

WARNING:



When servicing the electrical system, always remove the ground cable first followed by the positive cable from the battery. Generally, if the negative cable is grounded during removal, sparks will not occur. If the positive is grounded during removal, sparks will occur and could ignite explosive gases.

When battery is connected, follow these rules:

1. Disconnect negative (-) battery cable when working on or near the alternator.
2. Do not attempt to polarize alternator.
3. Make sure alternator wires are correctly connected before connecting battery terminals.
4. Do not ground alternator output terminal.
5. Do not disconnect or connect alternator wires while battery is connected or while alternator is operating.
6. Connect battery or booster battery in the correct polarity [positive (+) to positive (+) and negative (-) to negative (-)].
7. Do not disconnect battery when engine is running and alternator is charging.
8. Disconnect battery cables before connecting battery charger to battery.

FUSES

The fuse block is mounted inside the engine compartment front access door.

CAUTION:



Replace fuses and circuit breakers with correct amperage to prevent damage from system overload.

TABLE 4-4. BLADE TYPE FUSE CODES

NUMBER	AMPERAGE RATING	CIRCUIT
1	7.5	Steering Switches
2	5	Auger Lift, Hopper Lift
3	5	Steering Computer Power
4	7.5	Top-Con Power
5	5	Front Wheel Alignment
6	5	Rear Wheel Height Adjustment
7	5	Auxiliary Part
8	40	Main Power
9	70	Glow Plug

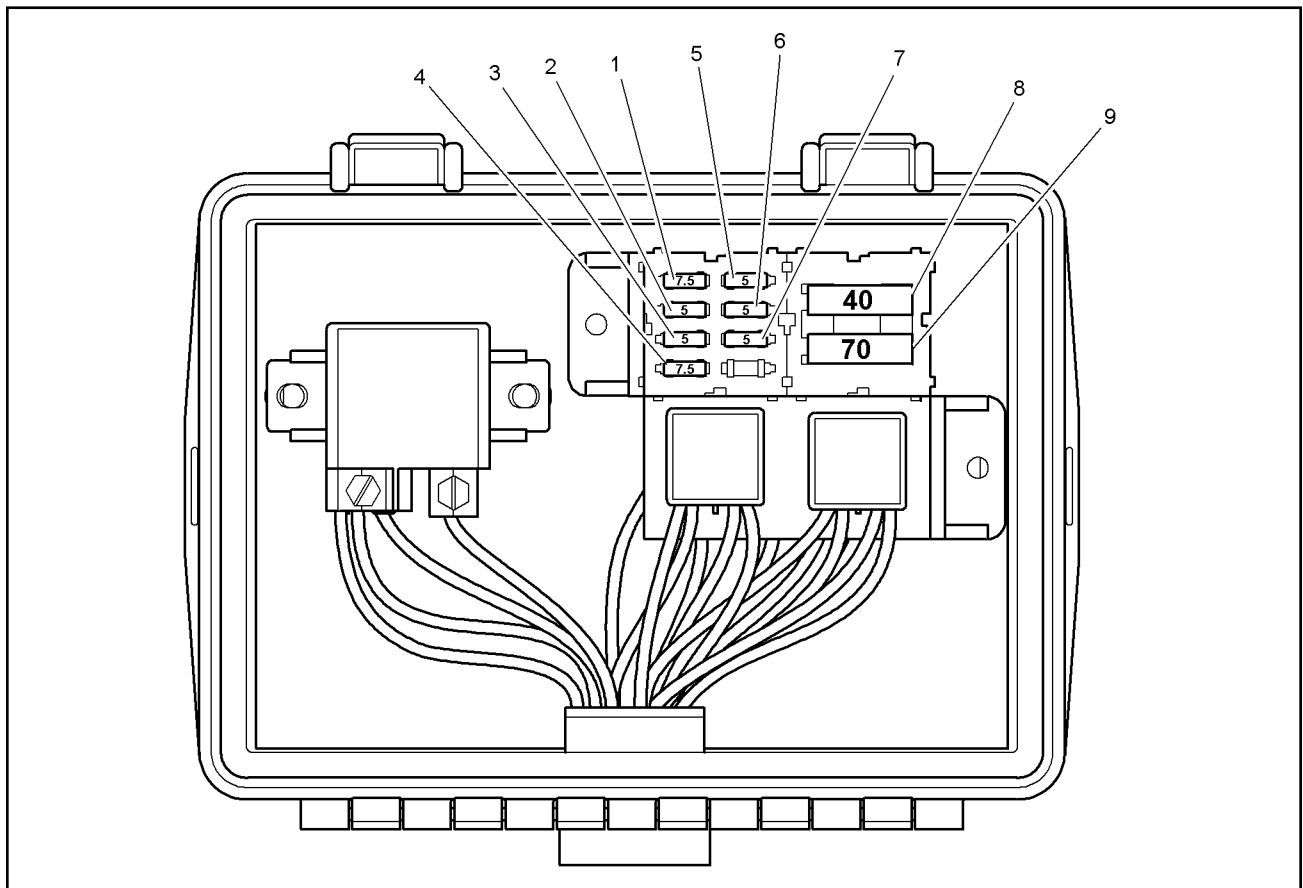

FIGURE 4-5. FUSE BLOCK

Section 4 MAINTENANCE



STEERING CALIBRATION

If any of the steering sensors are replaced because of damage or malfunction, the Top-Con system must be re-calibrated. To do so, follow the steps listed below. See Figure 4-6.

1. Start the engine.
2. Turn the Master Power switch ON.
3. Turn the Steering Computer OFF.
4. Walk to the front of the machine and make sure that the front wheel is straight ahead. Be sure the line sensor wands are straight up and down.
5. Move the Steering Selector switch up and down 3 times within 3 seconds. The turn indicator lights will blink simultaneously, indicating that the system is ready to calibrate.
6. Turn the Steering Computer ON then OFF to save the settings. Both turn lights should go out indicating that the steering sensor is calibrated in a straight position.

HYDRAULIC SYSTEM

CHECKING HYDRAULIC OIL LEVEL

1. Refer to PREPARING MACHINE FOR MAINTENANCE and park machine.
2. Make sure all cylinders are retracted.
3. Wait ten minutes for oil to drain after engine has been shut down.
4. Check hydraulic tank sight gauge. The hydraulic oil level should be in the upper half of the sight gauge but never above the upper fill line.
5. Add AW32 hydraulic oil as needed.

CHANGING LOW-PRESSURE HYDRAULIC FILTER

1. Refer to PREPARING MACHINE FOR MAINTENANCE and park machine.
2. Allow the engine to cool completely.
3. Locate the hydraulic filter on the right side of the Curber (Figure 4-7).

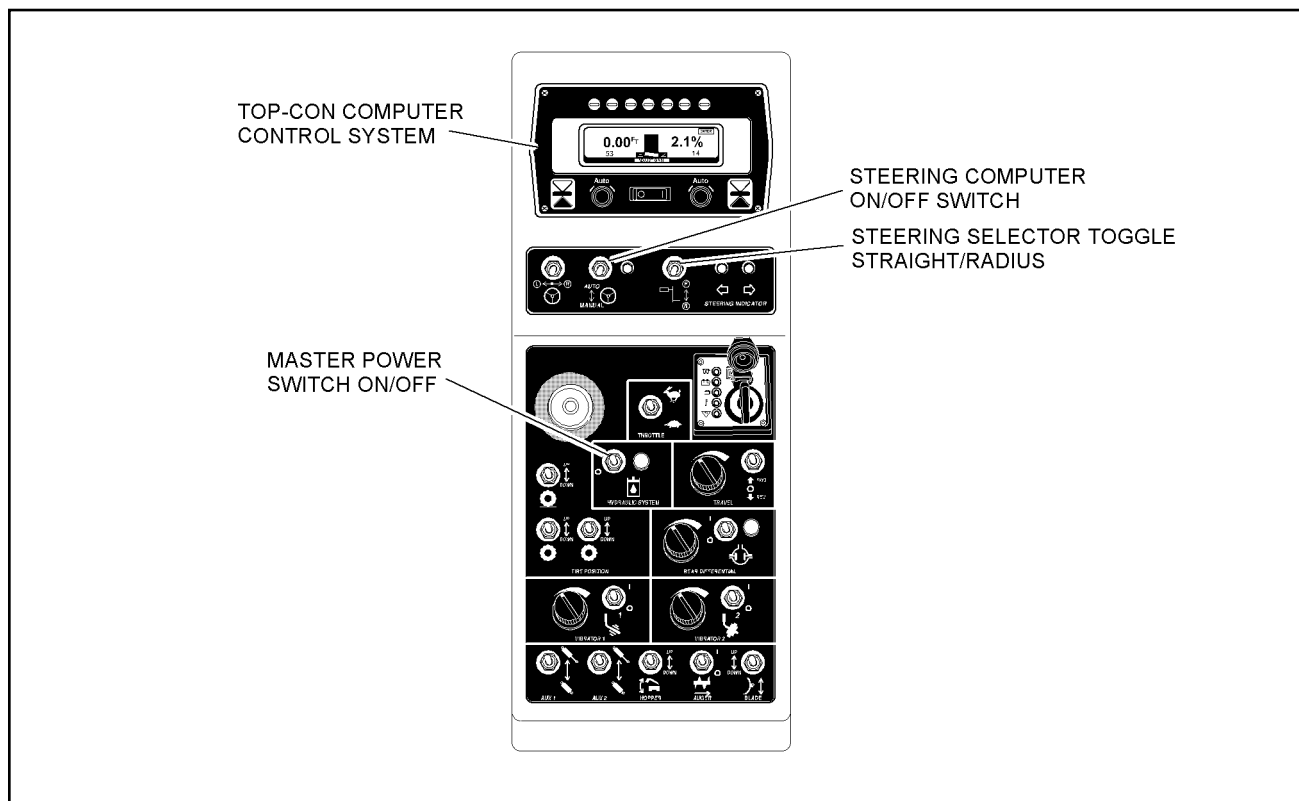
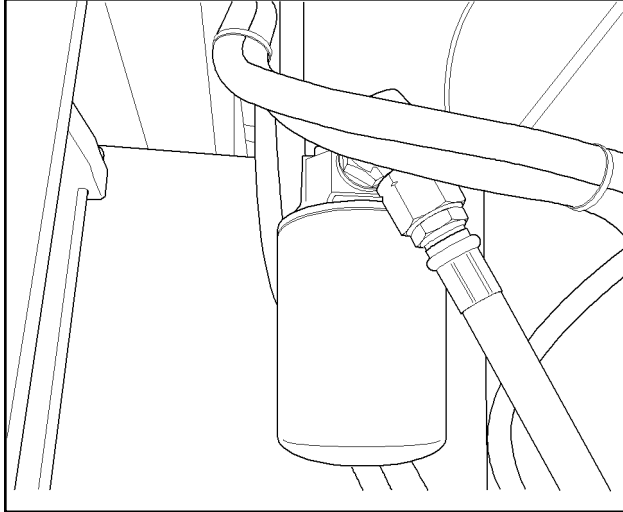

FIGURE 4-6. STEERING CALIBRATION

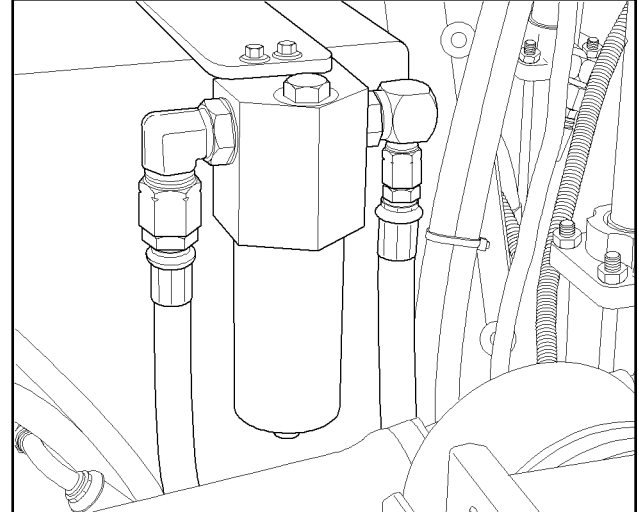

**FIGURE 4-7. LOW-PRESSURE
HYDRAULIC FILTER**

4. Thoroughly clean the filter and filter head.
5. Remove the hydraulic reservoir filler cap.
6. Turn the filter counterclockwise to remove. Clean the mounting surface and remove any loose filter seals in the filter head-mounting surface.
7. Lightly lubricate the filter seal with clean hydraulic oil.
8. Turn the filter clockwise until the seal contacts the mounting surface. Tighten the filter 1/2 to 3/4 additional turn.
9. Start engine and check for leaks. Tighten or replace filter as necessary.

CHANGING HIGH-PRESSURE HYDRAULIC FILTER

1. Refer to PREPARING MACHINE FOR MAINTENANCE and park machine.
2. Allow the engine to cool completely.
3. Locate the high-pressure hydraulic filter (Figure 4-8) inside the engine compartment.
4. Thoroughly clean the filter and filter head with a lint-free cloth.
5. Remove the hydraulic reservoir filler cap.
6. Turn the filter bowl counterclockwise to remove. Clean the mounting surface using a lint-free cloth, and remove any loose filter seals in the filter head-mounting surface.
7. Drain and remove the filter element from the filter bowl.



**FIGURE 4-8. HIGH-PRESSURE
HYDRAULIC FILTER**

8. Using solvent, thoroughly clean the bowl. Dry using compressed air.

WARNING: Wear eye protection and chemical resistant gloves when using solvent for cleaning purposes. Some solvent can cause skin irritation and eye damage.



WARNING: Wear eye protection when using compressed air for drying or cleaning components. Never point the nozzle at another individual. Use a safety reduction valve to reduce air pressure to a safe level. Compressed air can cause serious personal injury if misused.



9. Lightly lubricate the filter bowl seal with clean hydraulic oil.
10. Place element into bowl.
11. Install bowl on filter head and turn clockwise until the seal contacts the mounting surface. Tighten the filter 1/2 to 3/4 additional turn. Tighten filter bowl to 45 ft. lbs. (60.8 Nm) torque.
12. Check hydraulic level in reservoir and fill with AW32 as necessary.
13. Start engine and check for leaks. Tighten or replace filter as necessary.

Section 4

MAINTENANCE



CHECKING AND CLEANING HYDRAULIC RESERVOIR FILLER CAP

WARNING: Wear eye protection and chemical resistant gloves when using solvent for cleaning purposes. Some solvents can cause skin irritation and eye damage.



WARNING: Wear eye protection when using compressed air for drying or cleaning components. Never point the nozzle at another individual. Use a safety reduction valve to reduce air pressure to a safe level. Compressed air can cause serious personal injury if misused.



1. Remove filler cap and inspect for damage. Check cap for dirt and clogging.
2. Using solvent, clean cap thoroughly and dry with compressed air.
3. Check cap for free air flow. Replace if necessary.
4. Install cap.

DRAINING, FLUSHING, AND FILLING HYDRAULIC OIL RESERVOIR

1. Refer to PREPARING MACHINE FOR MAINTENANCE and park machine.
2. Remove reservoir filler cap.
3. Remove drain plug and drain the hydraulic oil into a suitable container. Dispose of oil properly.
4. Flush hydraulic reservoir completely.
5. Install drain plug.
6. Replace the suction filter.
7. Replace high-pressure filter.
8. Fill hydraulic oil reservoir to proper level.
9. Install filler cap.
10. Start engine and operate hydraulic control levers several times. Check hydraulic oil sight gauge and fill as necessary.

TIRES AND WHEELS

Check tires and wheels for cuts, bubbles, damaged rims, or missing wheel bolts or nuts.

The tires on the LBC-24W Curber are filled with silicone. A plug (Figure 4-9) is inserted into the tire to fill the hole used to fill the tires with silicone. This plug is normal and should not be removed.

ATTENTION: The tires should be serviced by a professional tire service center capable of repairing and filling tires with silicone.



CHANGING TIRES

DANGER: Do not work underneath a raised machine without adequate support such as jack stands. Serious injury or death can occur if the machine falls while service is being performed underneath.



1. Loosen, but do not remove, the wheel bolts. Use an allen wrench for an M-10 bolt.
2. Raise and block the machine.
3. Remove bolts and tire.
4. Install replacement tire on the machine; tighten lug nuts alternately in a star pattern 35 to 40 ft. lbs. (60 to 68 Nm).

TORQUE HUBS

Check the oil level in the torque hubs after the first 50 hours of service, then every 500 hours or semi-annually.

1. Remove the plug at the 3 o'clock position.
2. If oil comes out, no oil is needed. Insert plug and tighten.
3. If oil does not come out, remove plug at the 12 o'clock position and fill with 50W gear lubricant until oil starts to appear at the 3 o'clock position.
4. Replace both plugs and repeat process on other torque hubs.

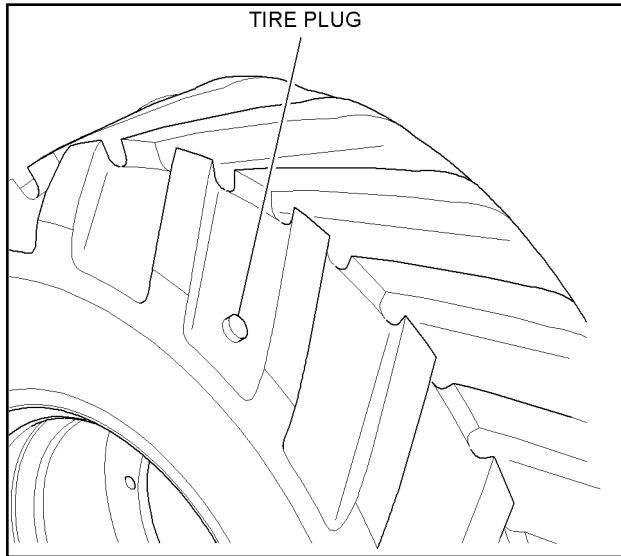

FIGURE 4-9. TIRE PLUG

STORAGE

PREPARING THE MACHINE FOR LONG-TERM STORAGE

A stored machine requires as much periodic maintenance as a machine at work. Stored units must receive periodic scheduled maintenance.

1. Inspect the machine thoroughly and repair worn or damaged parts.
2. Retract all hydraulic cylinders, if possible.
3. Shut down engine and remove ignition key.
4. Remove alternator belt.
5. Remove the battery and store in a cool, dry place.
6. Check air filter restriction gauge. Clean the air cleaner assembly and precleaner. Replace air filter elements if restricted.
7. Clean the machine. Paint chipped or rusty areas to prevent rusting. Replace worn or damaged decals.
8. Place a "DO NOT OPERATE" tag on the steering wheel.

ATTENTION: Some rust inhibitors can destroy painted surfaces. Do not spray rust inhibitor on painted surfaces.



9. Coat exposed cylinder rods with rust inhibitor.
10. Lubricate all grease points. Refer to MAINTENANCE SCHEDULE earlier in this section.
11. Check engine oil level and fill as necessary.
12. Check hydraulic oil sight gauge and fill as necessary.
13. Perform specific gravity test on engine coolant. Drain and replace or fill coolant reservoir as needed to prevent freeze damage.
14. If possible, raise and support machine with tires off the ground or park machine on a hard surface to prevent tires from freezing to ground.
15. Store machine in a dry, protected area. If stored outside, cover with waterproof material.

PERIODIC MAINTENANCE DURING STORAGE

If a unit will not be used for more than two months, refer to Table 4-1, Maintenance Interval Chart, and follow procedures for 100-Hours interval, as well as these preventive maintenance procedures:

1. Keep battery fully charged and check the level of the electrolyte regularly.
2. Check for water in hydraulic fluid. Any machine that is stored for an extended period in a climate that has a wide range of temperatures and/or humidity, will develop condensation on the inside of the tank walls. Check the hydraulic fluid on a regular basis for possible moisture contamination.

ATTENTION: Hydraulic oil that is contaminated, must be drained, the filter elements replaced and the tank refilled with LeeBoy approved fluid. Failure to do this could result in premature failure of the pumps and/or motors.



3. Start and run the engine until it is warm. Cycle all hydraulic and/or hydrostatic functions until all components are warm and the hydraulic fluid is up to operating temperature.
4. After the machine is warmed up, grease all pivot points.

Section 4

MAINTENANCE



REMOVING THE MACHINE FROM STORAGE

1. Follow steps above in Periodic Maintenance During Storage.
2. Refer to Table 4-1, Maintenance Interval Chart. Check all fluid levels, belt tensions, and bolt torques.
3. Replace alternator belt.
4. Replace battery. Refer to Battery maintenance earlier in this section for additional instructions.
5. Clean grease or rust inhibitor from all exposed cylinder rods, seals, and o-rings.

DECAL INSTALLATION

1. Be sure that the installation area is clean and dry. Use hot soapy water and dry the area thoroughly before installing decals.
2. Determine the exact position by taking measurements and test fitting before you remove the backing paper.
3. For decals with no top protection paper, determine the decal location and remove the smallest portion of the split backing paper.
4. Align the decal over the specified area and carefully press the small portion with the exposed adhesive backing into place.
5. Peel back the remaining paper and carefully smooth the remaining portion of the decal in place.
6. Small air pockets can be pierced with a pin and smoothed out using the piece of decal backing paper.
7. If the decal has a protective top paper, use hot soapy water on the surface to which the decal is being applied. Leave wet. After determining the location, remove the backing paper and soak the decal in clean soapy water before application. This will help prevent air bubbles in the finished decal.
8. Smooth the decal into place with a sponge and check for air bubbles. Small air pockets may be pierced with a pin and smoothed out. When the decal is completely smoothed out, carefully remove the top paper.

TROUBLESHOOTING

GENERAL INFORMATION

The troubleshooting chart below identifies the most common symptoms of failure. Use this chart to help identify the failed component.

NOTE: The following troubleshooting solutions include common problems encountered with diesel engines. For additional information and troubleshooting procedures, see the engine manufacturer's manual.

TROUBLESHOOTING CHARTS

ENGINE PROBLEMS

SYMPTOM	CAUSE	REMEDY
Engine cranks but does not start or starts hard.	Fuel tank empty.	Check fuel level and fill as required.
	Fuel shut-off valve closed.	Open valve.
	Water in fuel or water frozen in fuel lines. Water frozen in fuel filter.	Thaw and/or drain water from fuel tank sump. Thaw ice in fuel lines and drain. Install new fuel filter.
	Fuel tank cap vent clogged.	Remove cap. Listen for air entering tank suddenly. Clean or replace cap.
	Debris or dirt in fuel.	Drain small amount of fuel from tank sump into clean container. Inspect for debris. Drain and flush fuel system and change fuel filter.
	Wrong grade fuel for low ambient temperature.	Fuel "jelled" in tank or lines. Warm machine. Drain fuel system and change fuel filter. Refill tank with correct fuel.
	Air entering suction side of fuel system.	Check for bubbles in fuel filter. Tighten connections. Inspect fuel lines for damage.
	Fuel transfer pump malfunctions.	Repair or replace fuel transfer pump.
	Air filter elements restricted with dirt, snow, or water.	Clean or replace filter elements.
	Injection pump malfunctions.	See your authorized dealer.
	Injection nozzle(s) malfunctions.	See your authorized dealer.
	Worn piston rings or low compression.	See your authorized dealer.
	Blown head gasket.	See your authorized dealer.

Section 4 MAINTENANCE



TROUBLESHOOTING CHARTS

ENGINE PROBLEMS (Continued)

SYMPTOM	CAUSE	REMEDY
Engine cranks slowly.	Wrong weight oil for low ambient temperature.	Drain and refill with correct weight oil. Change oil filter.
	Loose or dirty connections at battery.	Clean battery posts and cable ends. Reinstall cables.
	Loose or dirty connections at starter.	Clean connections at start relay and starter.
	Battery cables damaged or broken.	Replace cables.
	Battery discharged or failing to take a charge.	Disconnect battery from machine. Recharge battery. Replace battery if it fails to charge. Check alternator output (12 volts), wiring for shorting to ground, and alternator belt tension. Repair or replace components as required.
	Starter motor malfunctions. Seized bushings, bent armature shaft, worn bushings, and armature "dragging".	Check starter current draw. See your authorized dealer for starter repair.
Engine surges or stalls frequently.	Air entering suction side of fuel system.	Check fuel filter for air bubbles. Tighten fittings and connections. Inspect lines for damage.
	Fuel tank cap vent clogged.	Remove cap. Listen for air entering tank suddenly. Clean or replace cap.
	Water or debris in fuel.	Drain water from sump in fuel tank. Check drained fuel for debris. Drain and flush fuel system. Replace fuel filter.
	Fuel "jelled" due to low ambient temperature.	Drain fuel system. Refill engine with correct grade fuel. Replace fuel filter.
	Fuel filter clogged.	Check for debris in fuel system. Replace filter.
	Return line from injection pump to tank restricted.	Check line for kinks or damage. Check line for debris. Clean with compressed air.
	Air filter elements clogged.	Clean or replace air filter elements.
	Fuel transfer pump clogged.	Repair or replace pump. See your authorized dealer.
	Injection pump or nozzle(s) malfunctions.	See your authorized dealer.
	Basic engine malfunction. Leaking head gasket, sticking or burnt valves, valve clearance or valve timing incorrect, or worn or broken piston rings.	Refer to Kubota engine manual.

TROUBLESHOOTING CHARTS

ENGINE PROBLEMS (Continued)

SYMPTOM	CAUSE	REMEDY
Engine missing, operating erratically, or operating poorly at slow speed.	Air entering suction side of fuel system.	Check fuel filter for air bubbles. Tighten fittings. Inspect lines for damage.
	Water or debris in fuel.	Drain water from sump in fuel tank. Check drained fuel for debris. Drain and flush fuel system. Replace fuel filter.
	Fuel tank cap vent clogged.	Remove cap. Listen for air entering tank suddenly. Clean or replace cap.
	Return line from injection pump to tank restricted.	Check line for kinks or damage. Check line for debris. Clean with compressed air.
	Slow idle speed set too low.	Check for bent, worn, or loose speed control linkage. Repair as needed. Adjust linkage and reset slow idle speed.
	Fuel transfer pump malfunctions.	Repair or replace fuel transfer pump.
	Injection pump or nozzle(s) malfunctions.	See your authorized dealer.
	Incorrect valve clearance.	Adjust clearance.
	Basic engine malfunction: leaking head gasket, sticking or burnt valves, valve clearance or valve timing incorrect, or worn or broken piston rings.	Refer to Kubota engine manual.
Engine not developing full power.	Fuel filter clogged.	Check for debris in fuel system. Replace filter.
	Air filter elements clogged.	Clean or replace air filter elements.
	Water in fuel or wrong grade of fuel used.	Drain water from fuel tank sump or drain and flush fuel tank and refill with correct fuel. Replace fuel filter.
	Exhaust system restriction.	Check condition of muffler interior.
	Fast idle speed set too low.	Check for bent, worn, or loose speed control linkage. Repair as needed. Adjust linkage and reset fast idle speed.
	Incorrect valve clearance.	Adjust clearance.
	Fuel line or injection pump line restricted.	Clear restriction with compressed air. Replace line.
	Park brake dragging.	Adjust linkage. Check park brake disc for warping or scoring. Check park brake cable for binding. Overheating of park brake disc indicates dragging. Repair or replace park brake disc and/or park brake cable as required.

Section 4 MAINTENANCE



TROUBLESHOOTING CHARTS

ENGINE PROBLEMS (Continued)

SYMPTOM	CAUSE	REMEDY
Engine not developing full power (continued).	Service brakes dragging.	Check brake linkage for damage. Check brake valve for leakage. Check brake discs for warping or scoring. Dragging brakes could cause overheating of transmission/hydraulics or engine.
	Fuel shut-off cable binding or linkage out of adjustment.	Free cable or replace it. Check linkage for worn or damaged parts. Replace damaged parts and/or adjust linkage.
	Fuel transfer pump malfunctions.	Repair or replace fuel transfer pump.
	Injection pump or nozzle(s) malfunctions.	See your authorized dealer.
	Internal hydraulic system leakage.	Repair linkage. See your authorized dealer.
	Turbocharger gasket leakage.	Repair or replace. See your authorized dealer.
	Basic engine malfunction. Leaking head gasket, sticking or burnt valves, valve clearance or valve timing incorrect, or worn or broken piston rings.	Refer to Kubota engine manual.
Engine emits excessive black or gray exhaust smoke.	Restricted air filter element.	Check. Clean or replace air filter elements.
	Incorrect grade of fuel.	Drain and flush fuel tank and fill with correct grade of fuel. Replace fuel filter.
	Engine overloaded.	Remove load. Run at fast idle to clear the engine.
	Turbocharger gasket leakage.	Repair or replace. See your authorized dealer.
	Incorrect injection pump timing.	Repair or replace pump. See your authorized dealer.
	Excessive fuel delivery. Injection pump or nozzle(s) malfunctions.	See your authorized dealer.
Excessive blue or white exhaust smoke.	Engine will not start.	Cranking speed too slow.
	Incorrect grade of fuel used.	Drain and flush fuel tank and refill with correct grade of fuel. Replace fuel filter.
	Injection pump or nozzle(s) malfunctions.	See your authorized dealer.
	Basic engine malfunction: excessive oil consumption.	Refer to Kubota engine manual.

TROUBLESHOOTING CHARTS

ENGINE PROBLEMS (Continued)

SYMPTOM	CAUSE	REMEDY
Abnormal engine noise (rattle, knock, or squeal).	Low engine oil level.	Fill reservoir to correct level.
	Too lightweight engine oil used for high ambient temperatures.	Drain and refill reservoir with correct weight oil.
	Fuel in engine oil.	Drain and refill reservoir with correct oil. Check fuel system to find leakage and repair leaks.
	Loose or worn hydraulic pump drive coupling.	Repair or replace damaged coupling.
	Injection pump timing incorrect.	See your authorized dealer.
	Turbocharger bearing or turbine damaged.	Remove turbo air inlet hose and check vertical movement of shaft. Repair or replace shaft. See your authorized dealer.
	Excessive valve clearance.	Adjust clearance.
	Internal engine component wear.	Refer to Kubota engine manual.
Low engine oil pressure (oil pressure indicator light ON, red STOP light flashing, or alarm ON).	Low oil level.	Check oil level. Fill reservoir to correct level. Check for leaks. Repair leaks.
	Low viscosity (using winter oil in summer).	Drain, flush, and fill reservoir with correct weight oil.
	Oil diluted with fuel.	Drain and refill reservoir with correct oil. Check fuel system to find leakage and repair leaks.
	Oil pressure sensor faulty.	Replace oil pressure sensor.
	Oil pressure control valve faulty.	Repair or replace valve. See your authorized dealer.
	Oil pump intake screen clogged.	See your authorized dealer.
	Loose oil pump drive gear or worn pump housing.	See your authorized dealer.
	Internal engine component wear.	Refer to Kubota engine manual.
Engine overheats.	Low coolant level.	Fill radiator with coolant to correct level and check for leaks.
	Loose, worn, or broken fan belt.	Tighten or replace fan belt. Refer to Kubota engine manual.
	Worn pulley grooves, allowing belt slippage.	Replace pulleys and belt. Refer to Kubota engine manual.
	Radiator dirty or clogged.	Check airflow. Clean radiator and recheck airflow.
	Radiator shroud missing or damaged.	Replace radiator shroud. Refer to Kubota engine manual.
	Engine overloaded.	Reduce load. Operate in lower gear.
	Radiator cap not sealing.	Replace radiator cap.
	Fan on backwards or damaged.	Inspect and reinstall or replace fan. Refer to Kubota engine manual.

Section 4 MAINTENANCE



TROUBLESHOOTING CHARTS

ENGINE PROBLEMS (Continued)

SYPTOM	CAUSE	REMEDY
Engine overheats (continued).	Injection pump timing incorrect.	See your authorized dealer.
	Thermostats stuck or missing.	Replace thermostats. Refer to Kubota engine manual.
	Cooling system interior coated with lime deposits.	Flush the cooling system with cleaner. Refill with water/antifreeze solution.
	Water pump leaking.	Repair or replace water pump. Refer to Kubota engine manual.
	Excessive fuel delivery or injection pump malfunctions.	See your authorized dealer.
Oil in coolant or coolant in oil.	Leaking cylinder head gasket or liner packings. Cracked cylinder or block.	Refer to Kubota engine manual.
Excessive Fuel Consumption.	Air system restricted.	Clean or replace air filter elements.
	Fuel system leakage.	Refer to Kubota engine manual.
	Incorrect grade of fuel.	Drain and flush fuel tank and refill with correct grade of fuel. Replace fuel filter.

TROUBLESHOOTING CHARTS

STARTER MOTOR PROBLEMS

SYMPTOM	CAUSE	REMEDY
Starter motor will not turn.	Battery not charged or bad.	Charge or replace battery.
	Battery connections.	Clean and tighten battery connections at battery and starter solenoid.
	Starter motor.	Listen for starter solenoid to click when key is placed in the start position. If solenoid clicks, repair or replace starter motor.
	Starter solenoid.	Check for 12 volts at small solenoid connections when key is placed in the start position. If 12 volts is present, replace solenoid.
	Start relay.	Listen for relay to click when key is placed in the start position. If relay does not click, check wiring. Repair or replace as necessary.
	Start system circuit breaker.	Check for 12 volts at both sides of the circuit breaker. If 12 volts is not present on either side, check wiring. If 12 volts is available on one side, replace circuit breaker.
	Key switch.	Check for 12 volts at ignition switch terminal "st" when key is placed in start position. If 12 volts is available, check wiring harness.
	Neutral start switch on pump.	Check for 12 volts on both sides of switch with machine in neutral. If 12 volts is available, check wiring harness. If 12 volts is available on one side only replace switch.
	Major engine malfunction.	See authorized dealer.
	Auger motor switch is ON.	Turn auger motor switch OFF.
Starter solenoid chatters.	Bad connections at battery or solenoid.	Clean and tighten connections.
	Battery discharged or bad.	Charge or replace battery.
	Bad solenoid.	Replace solenoid.
Starter motor turns but will not crank engine.	Starter pinion gear not engaging flywheel ring gear.	Pinion shift mechanism jammed. Repair or replace starter motor.
	Pinion gear teeth broken.	Repair or replace starter motor.
	Flywheel ring gear teeth broken.	Replace ring gear.

Section 4 MAINTENANCE



TROUBLESHOOTING CHARTS

STARTER MOTOR PROBLEMS (Continued)

SYMPTOM	CAUSE	REMEDY
Starter motor continues to turn after engine starts.	Starter solenoid stuck.	Gently tap solenoid. Replace solenoid.
	Starter pinion gear not disengaging from flywheel.	Gently tap starter motor. Repair or replace starter motor.
	Ignition switch malfunction.	Check for 12 volts at "st" terminal with ignition switch in the ON position. If 12 volts available, replace ignition switch.
Excessive noise when cranking engine.	Broken teeth on flywheel ring gear or starter pinion gear.	Replace starter motor or ring gear.
	Major engine malfunction.	See authorized dealer.

TROUBLESHOOTING CHARTS

HYDRAULIC SYSTEM PROBLEMS

SYMPTOM	CAUSE	REMEDY
No hydraulic power.	Low hydraulic/transmission oil level.	Add oil to the hydraulic oil reservoir to the correct level.
	Hydraulic filter clogged.	Replace filter element.
	Hydraulic pumps or pump drive coupling damaged or excessive leakage in hydraulic system.	See your authorized dealer.
	Master Power switch is OFF.	Turn Master Power switch ON.
All hydraulic functions slow.	Low oil level.	Add oil to the hydraulic oil reservoir to the correct level.
	Air in hydraulic oil (foamy appearance).	Inspect suction side hoses and fittings to pump for leakage. Tighten fittings or replace hoses and fittings as required.
	Engine rpm low.	Inspect speed control linkage for damage. Repair or replace parts as required and adjust linkage.
	Hydraulic filter clogged.	Replace filter element.
	Low pump flow or excessive leakage in system.	See your authorized dealer.
Hydraulic functions make "chattering" noise.	Low oil level.	Add oil to the hydraulic oil reservoir to the correct level.
	Hydraulic filter restricted.	Replace filter element.
	Hydraulic filter relief valve stuck open or setting is too low.	See your authorized dealer.
Hydraulic functions drift or settle.	Cylinder or control valve leakage.	See your authorized dealer.
	Control valve linkage binding or out of adjustment.	Repair and/or adjust linkage.
Hydraulics overheat.	Excessive load.	Reduce load.
	Oil cooler clogged.	Clean oil cooler and measure air flow.
	Low oil level.	Fill the hydraulic oil reservoir to the correct level.
	Using low viscosity oil in summer.	Drain, flush, and fill the hydraulic oil reservoir with the correct oil. Replace the oil filter.
	Transmission or hydraulic internal leakage.	See your authorized dealer.
	Hydraulic system overheating due to internal leakage.	Check for clogged hydraulic oil cooler. See your authorized dealer.

Section 4 MAINTENANCE



TROUBLESHOOTING CHARTS

HYDRAULIC SYSTEM PROBLEMS (Continued)

SYMPTOM	CAUSE	REMEDY
Foaming oil.	Oil level is too high or too low.	Adjust oil level to full mark on dipstick.
	Incorrect type of oil.	Drain, flush, and fill the hydraulic oil reservoir with the correct oil. Replace the oil filter.
	Pump suction screen restricted.	Clean the screen.
	Air leakage on suction side of pump.	Tighten fittings and inspect hoses for damage. Replace damaged hoses.
Excessive hydraulic pump noise.	Low oil level.	Fill the hydraulic oil reservoir to the correct level.
	Transmission or hydraulic filter restricted.	Replace filter.
	Aeration of oil - suction side leaking.	Tighten fittings and inspect hoses for damage. Replace damaged hoses.
	Worn pump, loose pump drive coupling, loose pump attaching hardware, leakage in hydraulic system (pump remains in stroke), or misalignment between pump and engine.	See your authorized dealer.

TROUBLESHOOTING CHARTS

ELECTRICAL PROBLEMS

SYMPTOM	CAUSE	REMEDY
Battery uses too much water.	Battery overcharged.	With battery fully charged, check alternator-charging rate. Repair or replace alternator.
	Cracked or broken battery case.	Replace battery.
Cracked battery case.	Battery hold down clamps too tight, loose or missing.	Replace battery and install hold down clamps properly.
	Frozen battery.	Replace battery. Keep battery fully charged during cold weather.
Low battery output.	Low water level.	Fill with distilled water and charge.
	Corroded or loose battery cable connections.	Clean and tighten all connections.
	Broken or loose battery posts.	Replace battery.
	Loose, slipping alternator belt.	Replace alternator belt.
	Low alternator output.	Test and replace alternator.
Alternator warning light stays on or voltmeter shows low charge.	Alternator drive belt loose or broken.	Tighten or replace drive belt.
	Alternator.	Load test alternator and replace as necessary.
Alternator charging rate too high (battery hot or boiling).	Alternator.	Load test alternator and replace as necessary.
Noisy alternator.	Alternator bearings.	Remove alternator belt and turn alternator by hand. If pulley turns rough, repair or replace alternator.
	Worn drive belt.	Check and replace belt.
	Internal alternator malfunction.	Repair or replace alternator.

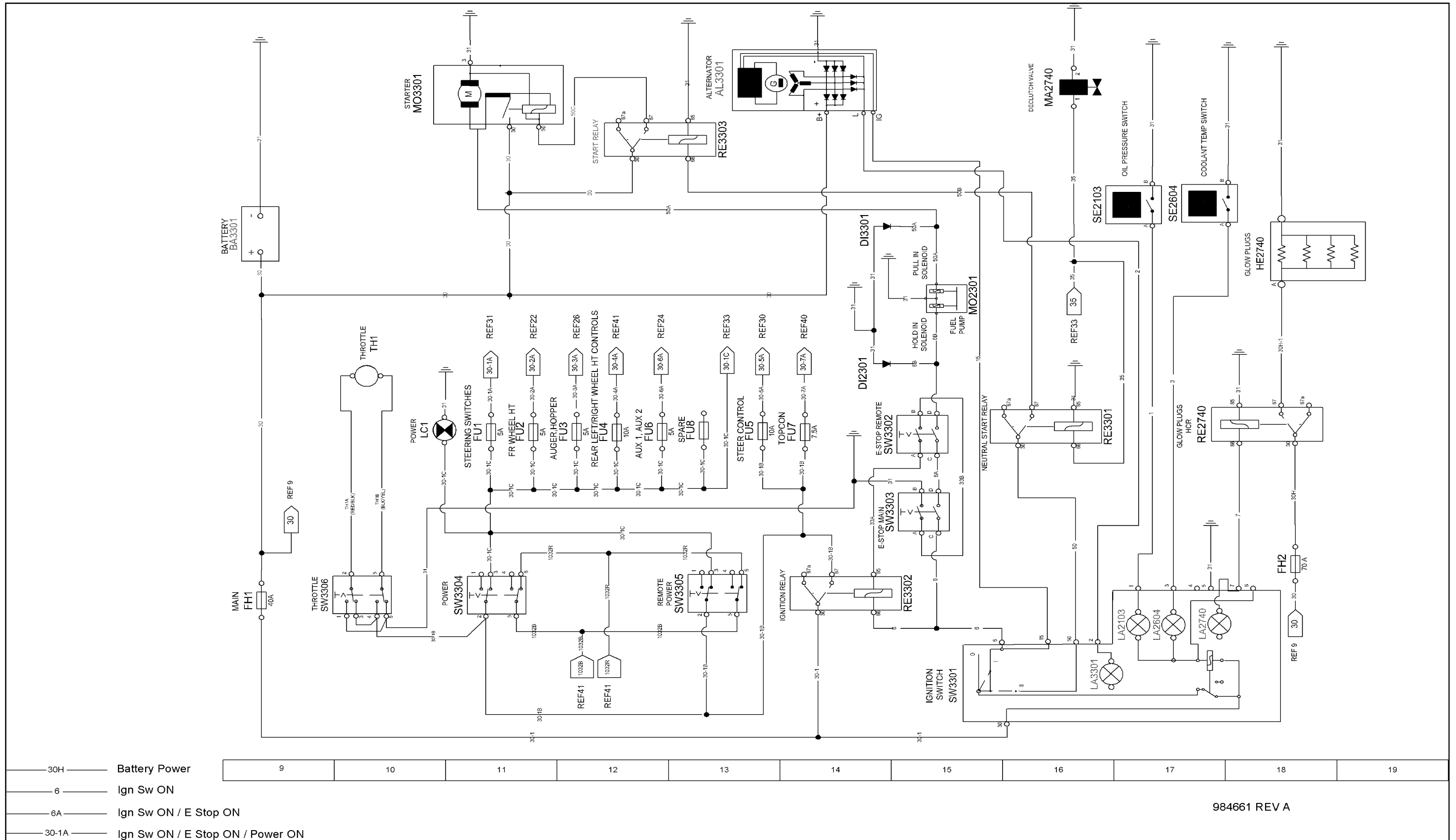

FIGURE 4-10. MAIN DIAGRAM, POSITIVE FEEDS/ENGINE

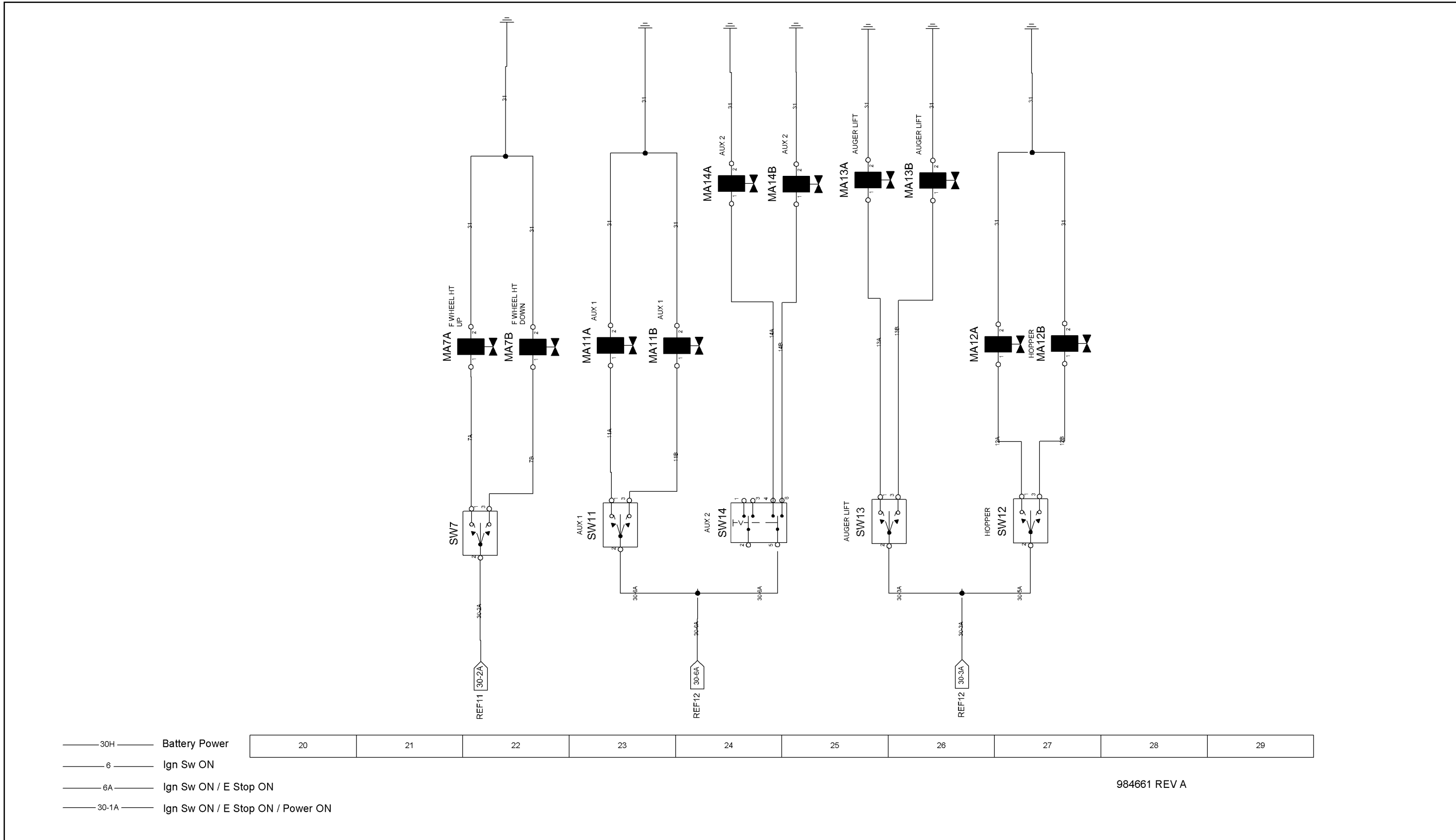
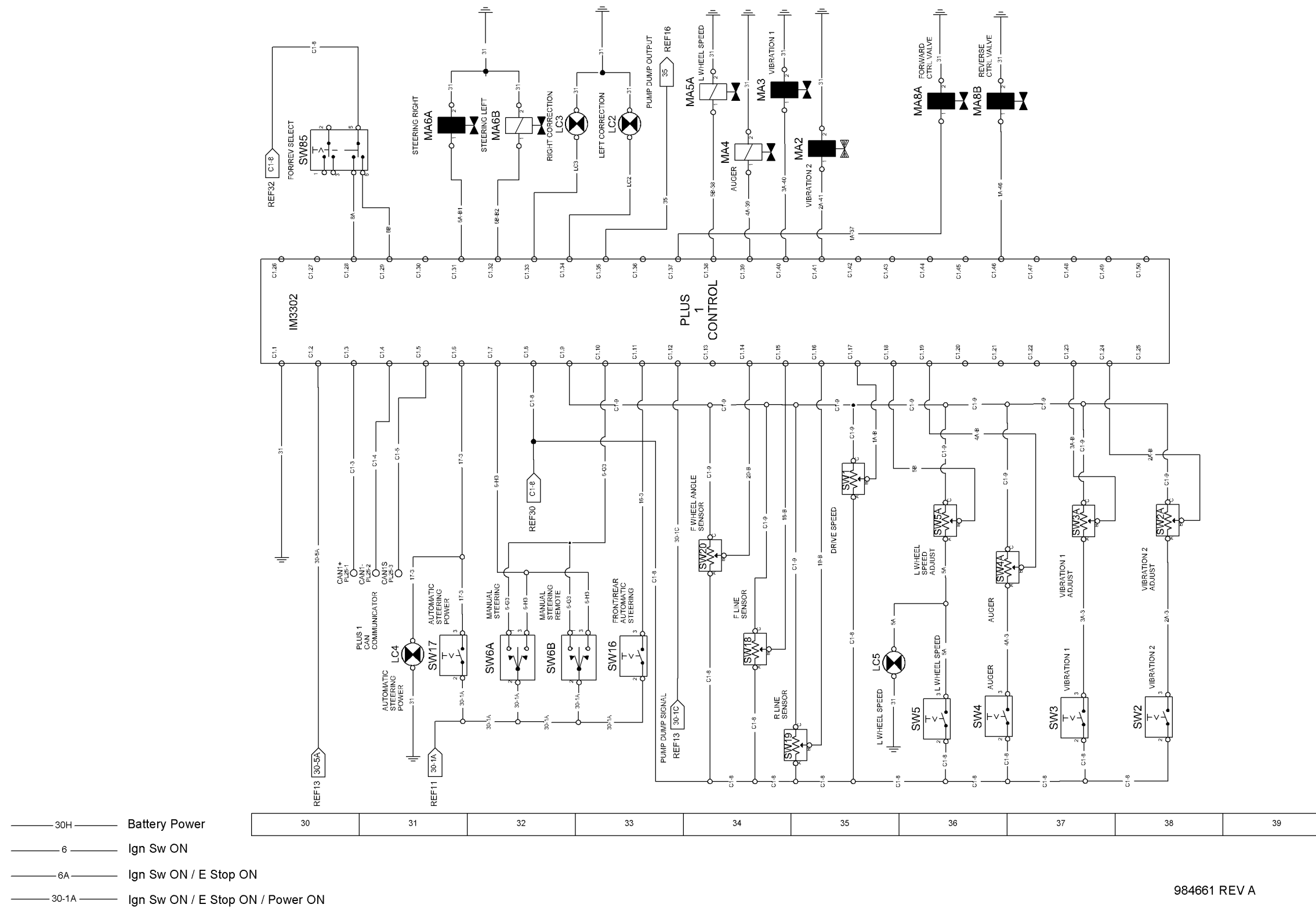

FIGURE 4-11. FRONT WHEEL HEIGHT, AUXILIARY 1 & 2, AUGER LIFT, AND HOPPER LIFT



984661 REV A

FIGURE 4-12. PLUS 1 CONTROLS

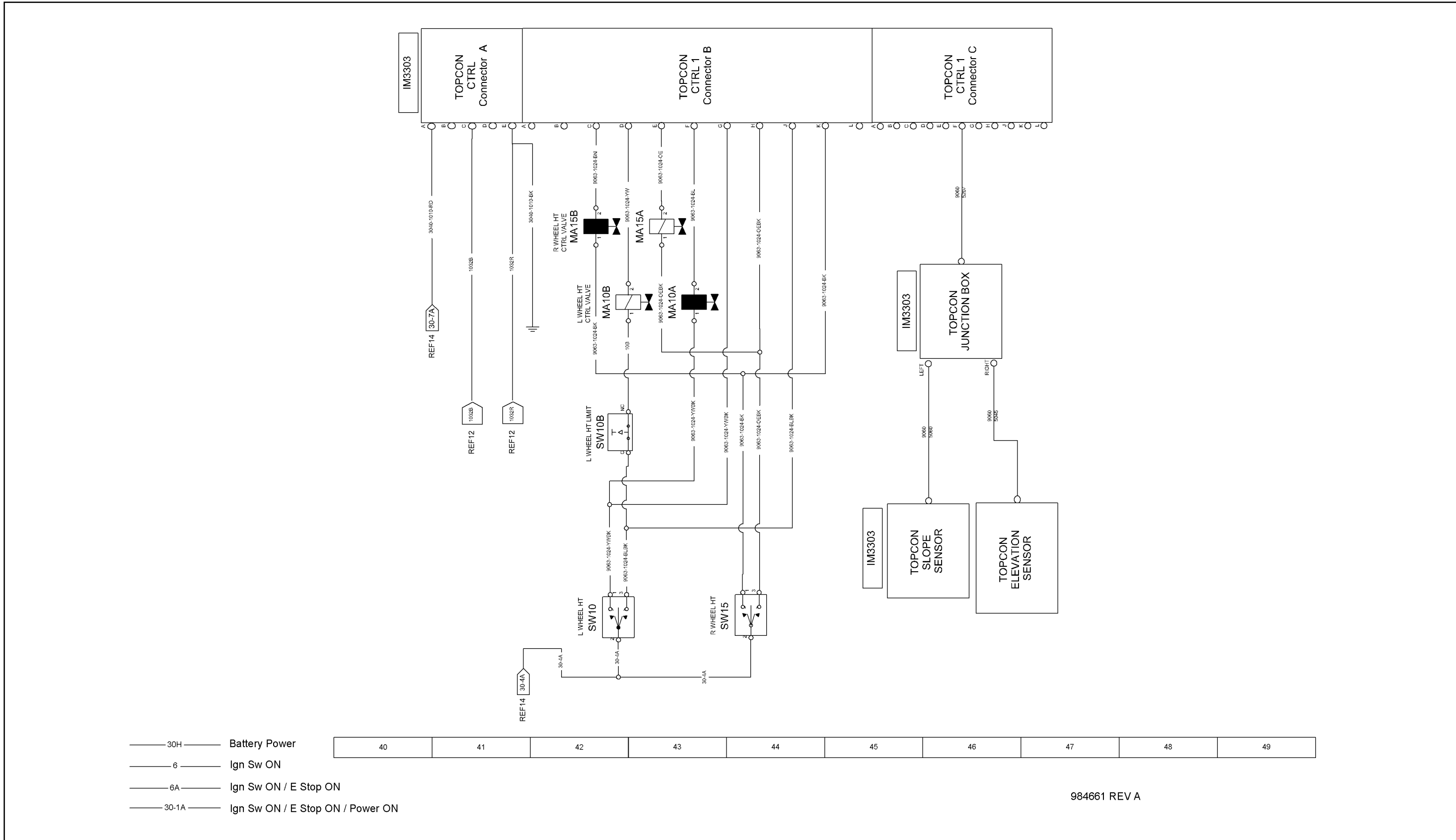

FIGURE 4-13. TOPCON CONTROLS

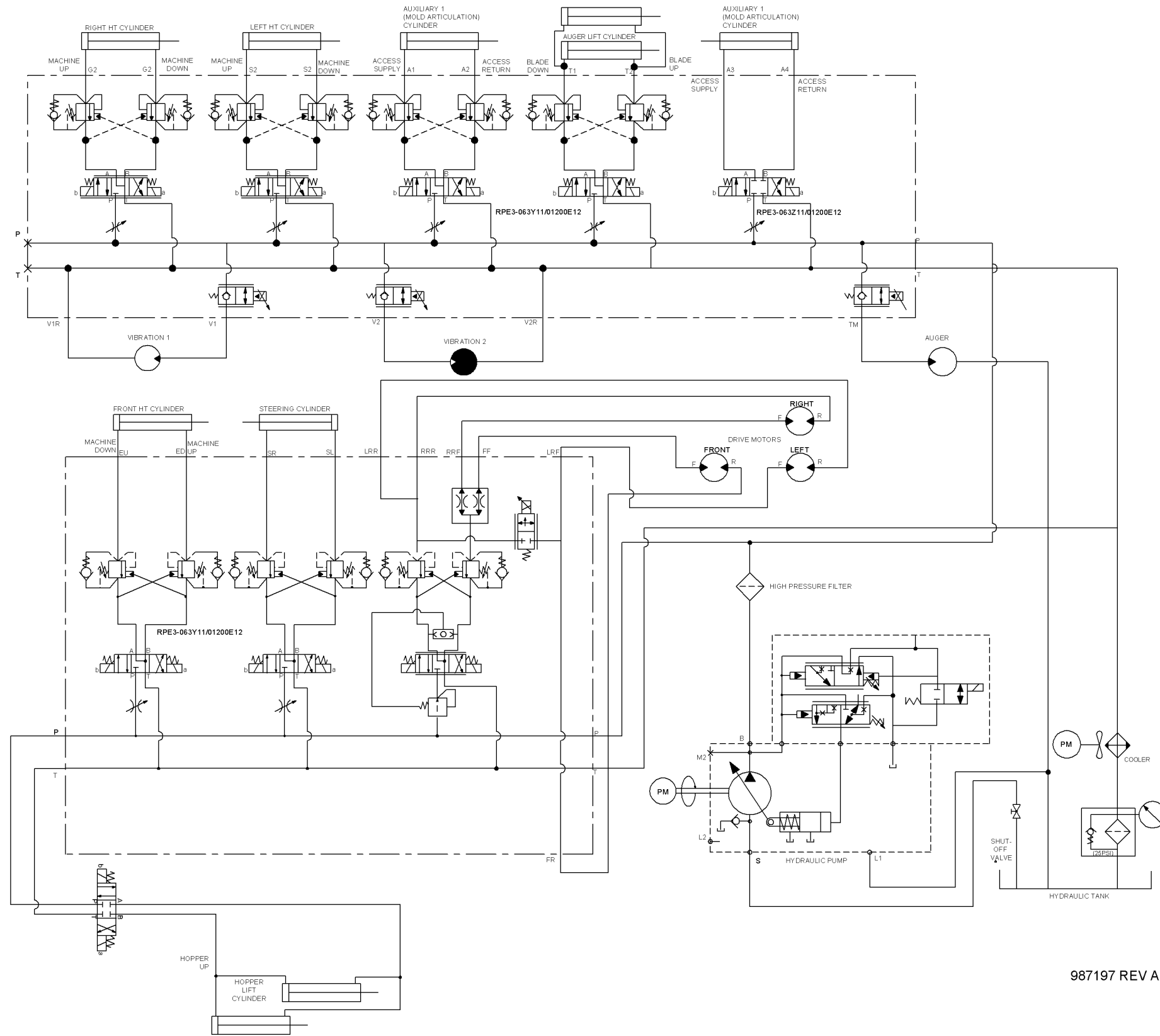

FIGURE 4-14. HYDRAULIC SCHEMATIC

TABLE OF CONTENTS

	Page
INTRODUCTION	IPL-3
GENERAL INFORMATION	IPL-3
ILLUSTRATED PARTS LIST	IPL-3
HOW TO USE THE IPL	IPL-3
GENERAL SYSTEM OF ASSEMBLY ORDER - ILLUSTRATED PARTS LIST	IPL-3
ALPHABETICAL INDEX	IPL-3
EQUIPMENT DESIGNATOR INDEX	IPL-3
FIGURE 1. TOP ASSEMBLY	IPL-4
FIGURE 2. ELECTRICAL GROUP	IPL-6
FIGURE 3. CONTROL CONSOLE	IPL-14
FIGURE 4. HYDRAULIC GROUP	IPL-22
FIGURE 5. VALVE ASSEMBLY	IPL-28
FIGURE 6. VALVE ASSEMBLY, REAR MANIFOLD	IPL-30
FIGURE 7. MOLD GROUP	IPL-32
FIGURE 8. COVER GROUP	IPL-34
FIGURE 9. FRAME ASSEMBLY	IPL-36
FIGURE 10. LEFT AND RIGHT WHEEL LIFT GROUP	IPL-38
FIGURE 11. WHEEL LIFT, FRONT	IPL-40
FIGURE 12. LEFT REAR TIRE, WHEEL & TORQUE HUB	IPL-42
FIGURE 13. RIGHT REAR TIRE & WHEEL & TORQUE HUB	IPL-44
FIGURE 14. FRONT TIRE, WHEEL & TORQUE HUB	IPL-46
FIGURE 15. ENGINE & FUEL FILTER	IPL-48
FIGURE 16. ENGINE COOLING SYSTEM	IPL-54
FIGURE 17. FUEL TANK	IPL-56
FIGURE 18. HYDRAULIC TANK	IPL-58
FIGURE 19. AUGER	IPL-60
FIGURE 20. SENSOR ARM	IPL-64
FIGURE 21. CONTROL PEDESTAL & TOW RING	IPL-66
FIGURE 22. ACCESS DOOR & COVER	IPL-68
ALPHABETICAL INDEX	IPL-73



Section 5 ILLUSTRATED PARTS LIST

INTRODUCTION

GENERAL INFORMATION

This Illustrated Parts List (IPL), as part of the Operations, Service and Parts Manual, is intended for use in identifying and requisitioning replacement parts.

ILLUSTRATED PARTS LIST

How to Use the IPL

- (1) The figure number refers to the corresponding illustration.
- (2) The item number corresponds to the item number shown for the part in the illustration.
- (3) If standard parts (those with AN, MS, NAF, NAS prefixes) are used the standard part number is listed in the part number column.
- (4) Part quantities listed are for one component or subcomponent. For example, if the parts list shows two platform assemblies, the quantities shown for the parts in the platform assembly is for one platform assembly.
- (5) Attaching parts are captioned ATTACHING PARTS and are listed immediately following the part(s) attached. The -----*----- symbol follows the last item of the attaching parts group. The quantity listed for the attaching parts is the quantity required to attach one item.
- (6) Parts with item numbers preceded with a dash are not illustrated.
- (7) If a company other than Leeboy is referred to as the original manufacturer of some of the parts, these parts may carry the original manufacturer's part number or a Leeboy part number. These manufacturer's are identified by an appropriate vendor code following the nomenclature. If the part number in the part number column is a Leeboy part number, the original manufacturer's part number is given after his vendor code. Vendor codes are in accordance with the current issue of Cataloging Handbook "Commercial and Government Entity" (H4-1 and H4-2) and are preceded by the capital letter "V".
- (8) When a Vendor Code cannot be obtained from the H4-1 and H4-2 Cataloging Handbook, the manufacturer's full name and address is included in the parts list. Government standard parts, such as, AN, MS, NAF, and NAS parts are not identified with a Vendor Code.

General System of Assembly Order - Illustrated Parts List

The indenture system used in the Illustrated Parts List shows relationship of parts and assemblies to next higher assemblies or installations, as follows:

1 2 3 4 5 6 7

Installation

- Detail parts for installation
- Assembly
- Attaching parts for assemblies
- -----*-----
- • Detail parts for assembly
- • Sub-assembly
- • Attaching parts for sub-assembly
- • -----*-----
- • • Detail parts for sub-assembly
- • • Assembly
- • • Attaching parts for sub-sub-assembly
- • • -----*-----
- • • • Detail parts for sub-sub-assembly

ALPHABETICAL INDEX

An alphabetical index is provided to supplement the Illustrated Parts List. Each index entry provides a reference to its appearance in the IPL by item number, part number, and page number.

EQUIPMENT DESIGNATOR INDEX

If equipment designators are used in place of part numbers at any place in the IPL, an Equipment Designator Index is provided listing all equipment designators listed in the Illustrated Parts List.

Section 5 ILLUSTRATED PARTS LIST

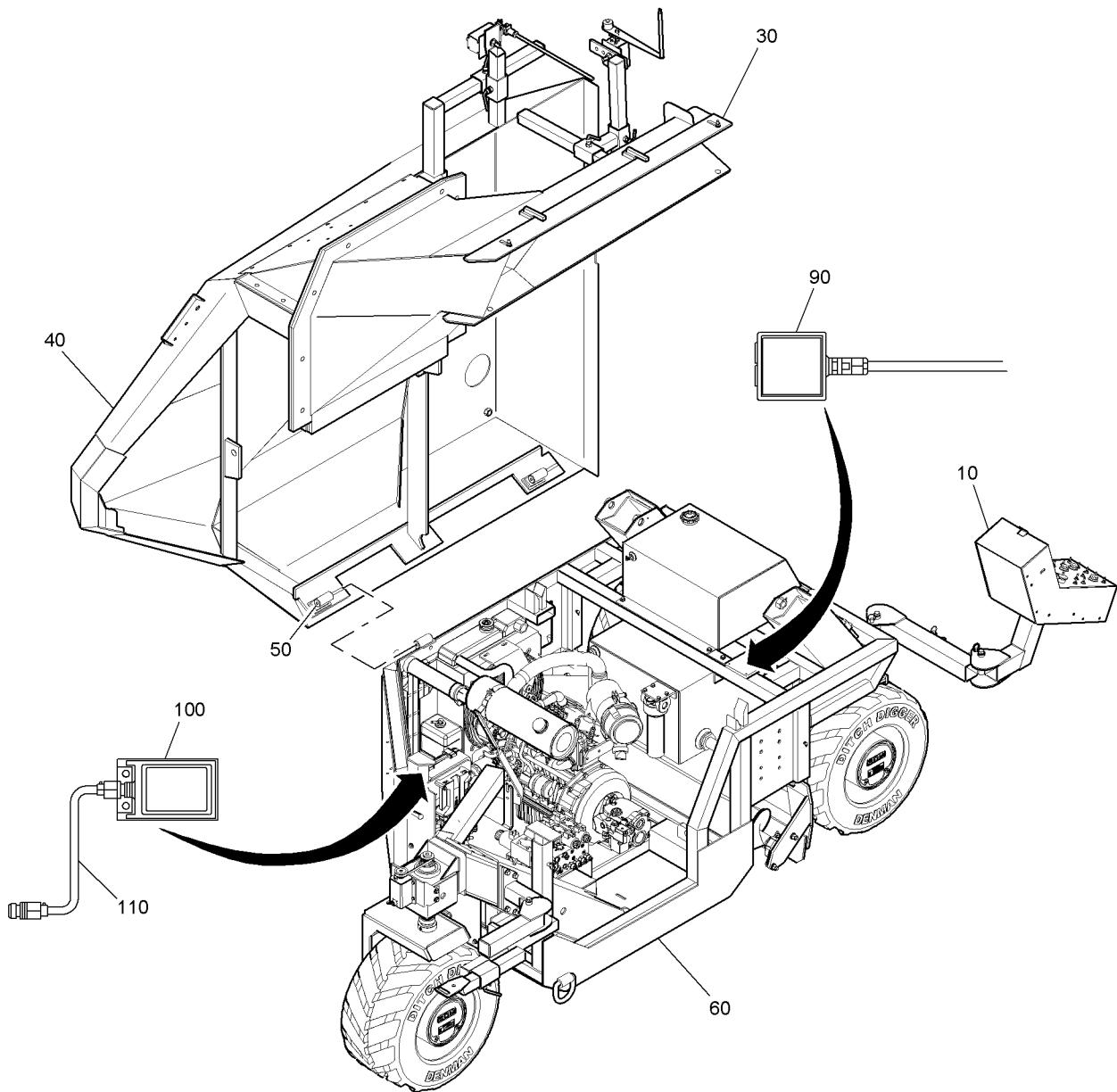

FIGURE 1. TOP ASSEMBLY



Section 5 ILLUSTRATED PARTS LIST

TABLE 1. TOP ASSEMBLY

ITEM NO.	PART NO.	DESCRIPTION	QTY.
1			
-1	983700	LBC24W44 CURBER	1
10	987198	*GROUP, ELECTRICAL (See Fig 2 for Breakdown)	1
-20	987197	*GROUP, HYDRAULIC (See Fig 4 for Breakdown)	1
30	986878-06	*GROUP, MOLD (See Fig 7 for Breakdown)	1
40	987344	*GROUP, COVER (See Fig 8 for Breakdown)	1
		ATTACHING PARTS	
50	984080	*HINGE, MALE	2
		-----*	
60	984190	*GROUP, FRAME (See Fig 9 for Breakdown)	1
-70	983607	*KIT, DECAL, SAFETY/OPS	1
-80	984600	*KIT, DECAL, LOGO	1
90	984199-08	*J-BOX, TOPCON	1
100	984199-06	*SENSOR, SLOPE, TOPCON	1
110	984199-03	*HARNES, SLOPE SENSOR, TOPCON	1

- ITEM NOT ILLUSTRATED

Section 5 ILLUSTRATED PARTS LIST

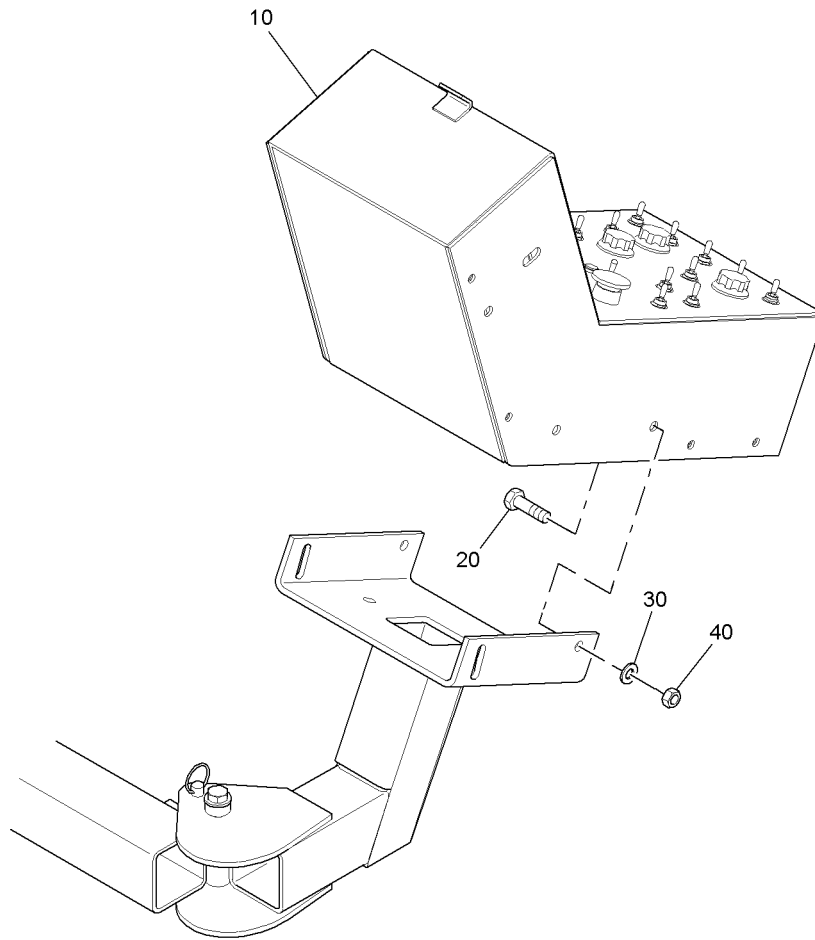

FIGURE 2. ELECTRICAL GROUP (1 OF 4)



Section 5 ILLUSTRATED PARTS LIST

TABLE 2. ELECTRICAL GROUP (1 OF 4)

ITEM NO.	PART NO.	DESCRIPTION	QTY.
2			
-1	987198	GROUP, ELECTRICAL, CURBER (See Fig 1 for NHA)	1
10	987335	*GROUP, CONTROL CONSOLE (See Fig 3 for Breakdown)	1
		ATTACHING PARTS	
20	102-205-1A	*CSHH, .375-16 X 1.00, GR5	4
30	118-3	*WASHER, LOCK, .375	4
40	116-3	*NUT, HEX, .375-16	4
		-----*	

- ITEM NOT ILLUSTRATED

Section 5 ILLUSTRATED PARTS LIST

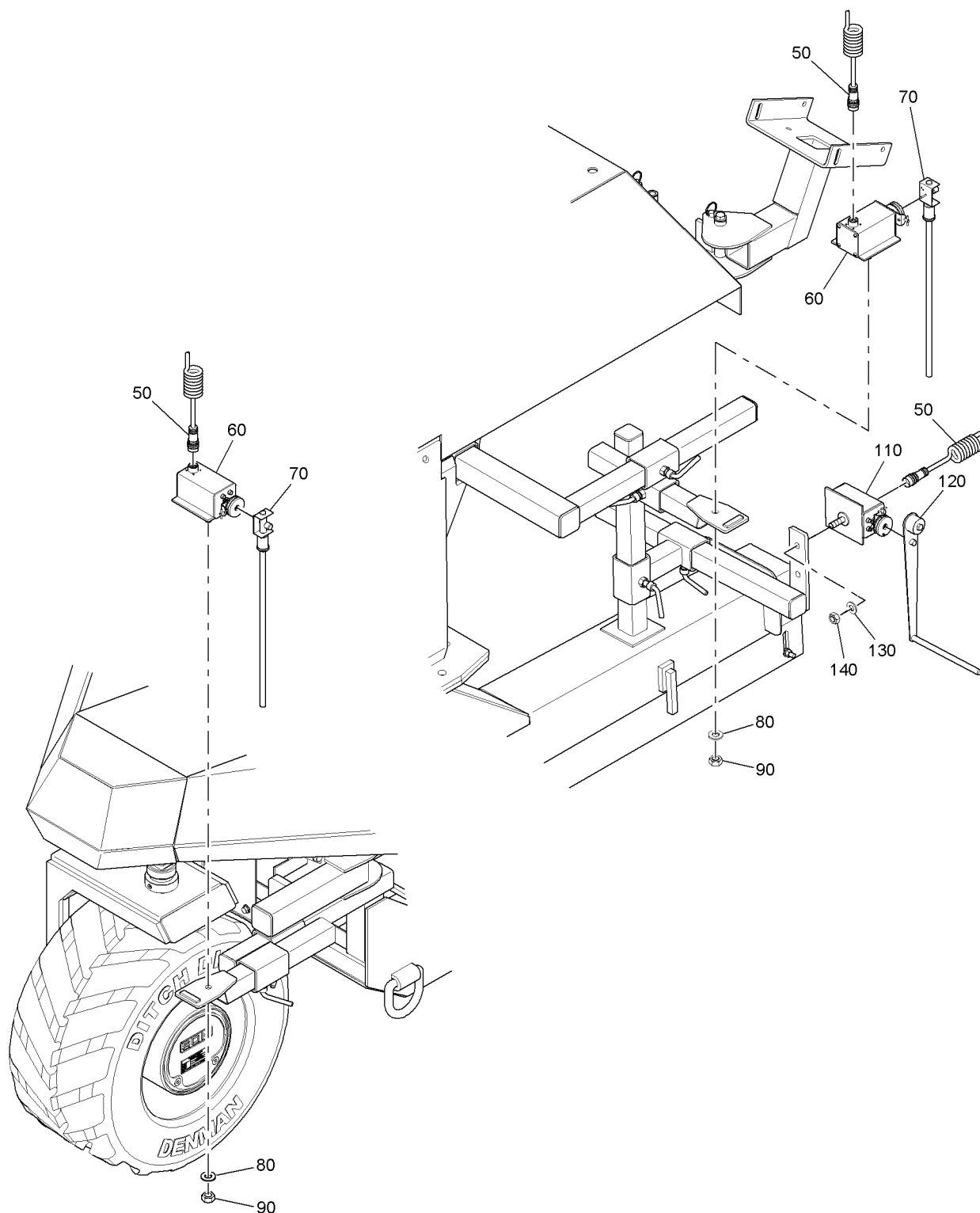

FIGURE 2. ELECTRICAL GROUP (2 OF 4)



Section 5 ILLUSTRATED PARTS LIST

TABLE 2. ELECTRICAL GROUP (2 OF 4)

ITEM NO.	PART NO.	DESCRIPTION	QTY.
50	983050	*COILED CORD, 6S16S 1.5 TO 7.5 FT.	4
60	985921	*SENSOR, ROTATING, STRING LINE	1
70	985922	*SENSOR, WAND	1
		ATTACHING PARTS	
80	118-5	*WASHER, LOCK, .500	1
90	116-5	*NUT, HEX, .500-13	1
		-----*	
-100	984200	*KIT, RS485 WAND SENSOR, TOPCON	1
110	984199-09	**SENSOR, ROTATING, STRING LINE	1
120	984199-10	**ARM, SENSOR, MOLD	1
		ATTACHING PARTS	
130	118-5	*WASHER, LOCK, .500	1
140	116-5	*NUT, HEX, .500-13	1
		-----*	

- ITEM NOT ILLUSTRATED

Section 5 ILLUSTRATED PARTS LIST

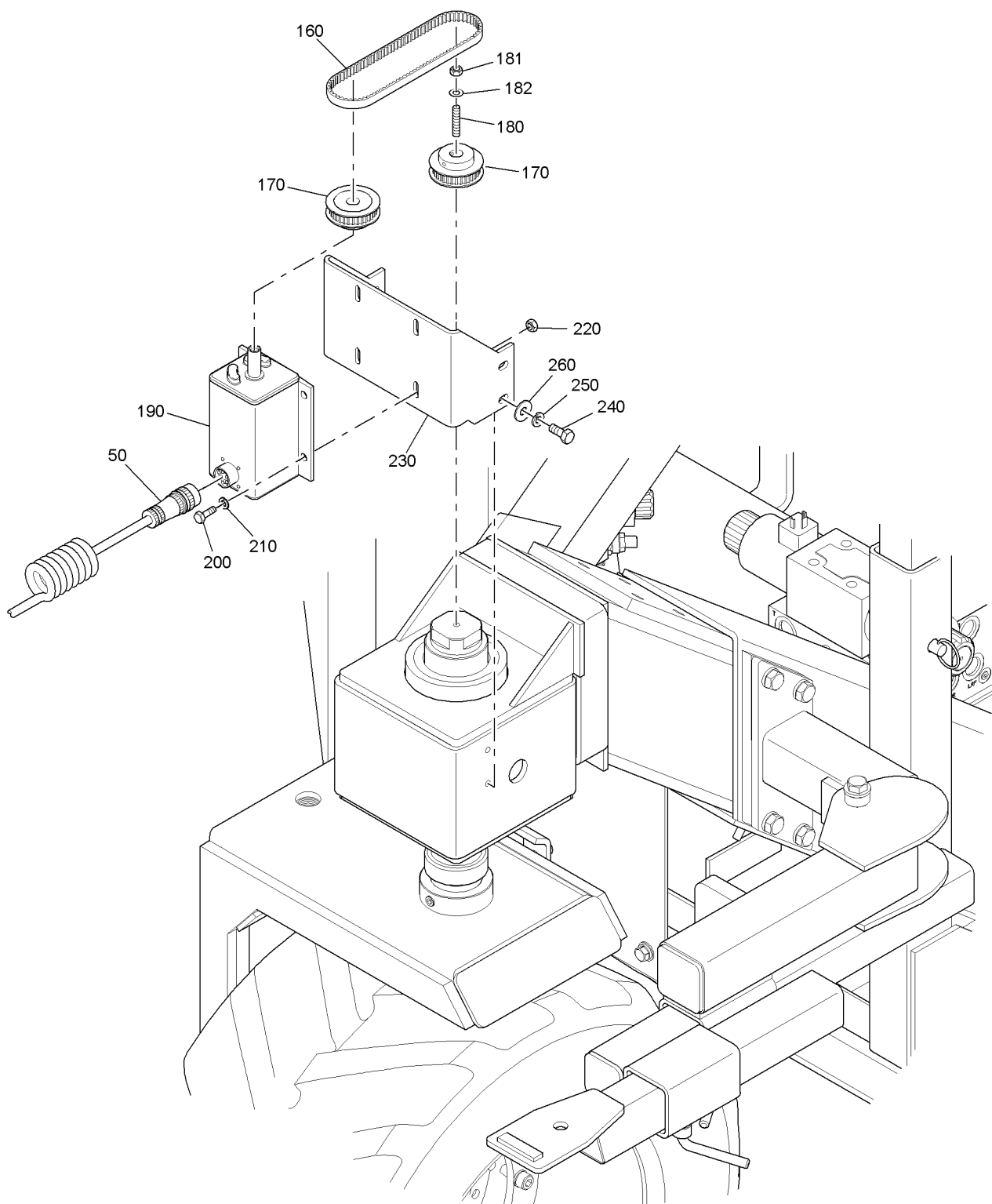

FIGURE 2. ELECTRICAL GROUP (3 OF 4)



Section 5 ILLUSTRATED PARTS LIST

TABLE 2. ELECTRICAL GROUP (3 OF 4)

ITEM NO.	PART NO.	DESCRIPTION	QTY.
50	983050	*COILED CORD, 6S16S 1.5 TO 7.5 FT.	4
-150	985928	*GROUP, FRONT WHEEL SENSOR	1
160	987048	**BELT, GEAR, XL, 85 TOOTH	1
170	985916	**PULLEY, GEARBELT, STEERING	2
		ATTACHING PARTS	
180	22025	*THD'D ROD, .312-18 X 2.50,GR5	1
181	143-2	*NUT, LOCK, .312-18	1
182	119-2	*WASHER, FLAT, SAE, .312	1
		-----*	
190	985915	**SENSOR, ROTATION	1
		ATTACHING PARTS	
200	102-7-1A	*CSHH, .250-20 X 1.50, GR5	4
210	118-1	*WASHER, LOCK, .250	4
220	116-1	*NUT, HEX, .250-20	4
		-----*	
230	987251	**BRACKET, PULLEY MOTOR	1
		ATTACHING PARTS	
240	80206	*CSHH, .312-18 X 1.25, GR5	4
250	118-2	*WASHER, LOCK, .312	4
260	119-2	*WASHER, FLAT, SAE, .312	4
		-----*	

- ITEM NOT ILLUSTRATED

Section 5 ILLUSTRATED PARTS LIST

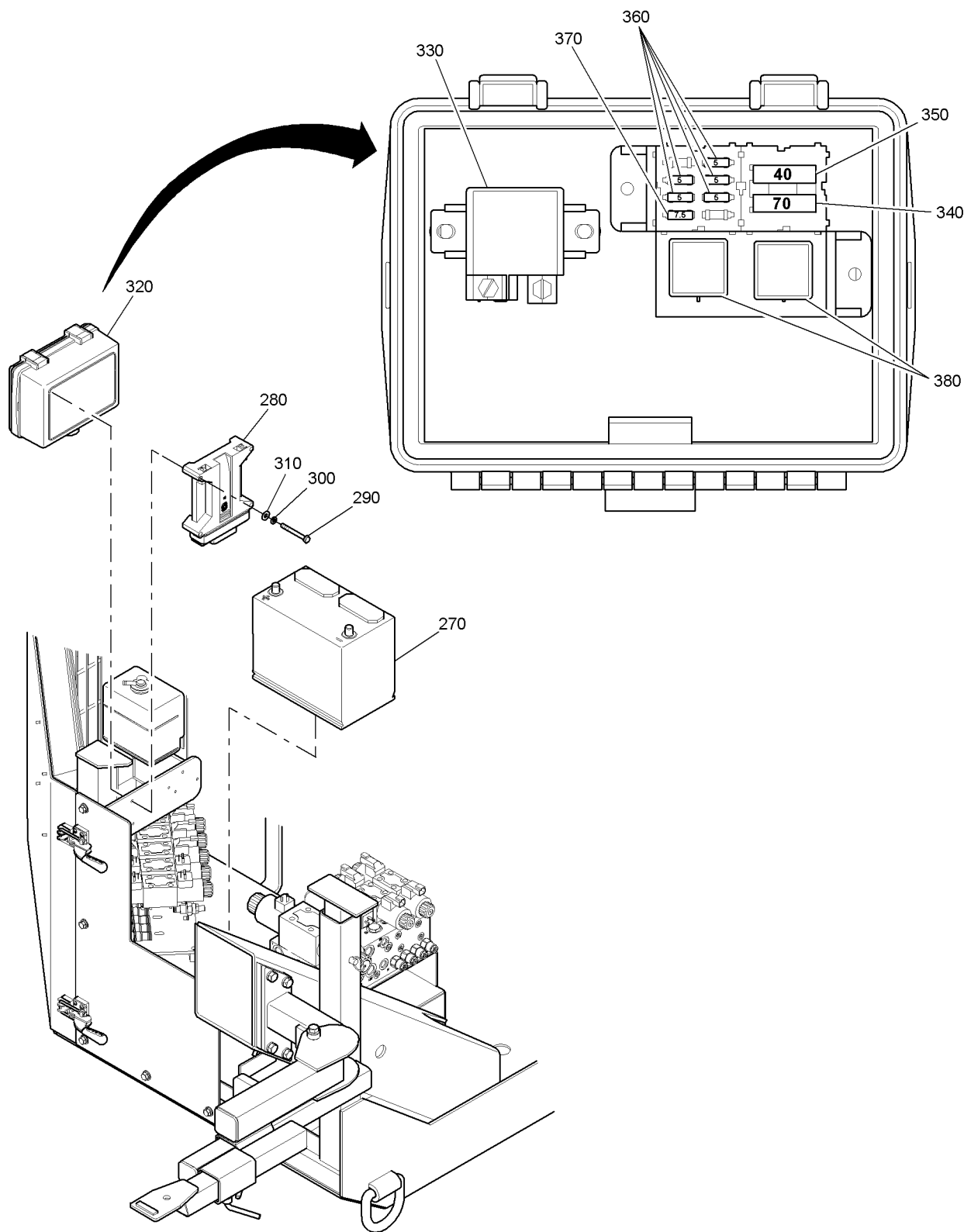

FIGURE 2. ELECTRICAL GROUP (4 OF 4)



Section 5 ILLUSTRATED PARTS LIST

TABLE 2. ELECTRICAL GROUP (4 OF 4)

ITEM NO.	PART NO.	DESCRIPTION	QTY.
270	314230	*BATTERY, 12 VOLT 650 CCA	1
280	985925	*MICRO PROCESSOR, PLUS 1, CURBER	1
		ATTACHING PARTS	
290	102-11-1A	*CSHH, .250-20 X 2.50	2
300	118-1	*WASHER, LOCK, .250	2
310	119-1	*WASHER, FLAT, SAE, .250	2
		-----*	
320	985913	*ASSEMBLY, FUSEBOX, CURBER	1
330	984155	**RELAY, 75 AMP, 12VDC	1
340	984673	**FUSE, 70 AMP, (MAXI)	1
350	984674	**FUSE, 40 AMP, (MAXI)	1
360	985747	**FUSE, 5 AMP, ATM(MINI)	5
370	984676	**FUSE, 7.5 AMP, ATM(MINI)	1
380	36085	**RELAY, 12VDC, CUBE, UNSEALED	2
-390	986044	*RELAY MOUNT, STARTER, W/M	1
-400	984662	*HARNESS, FRAME, CURBER - See Section 4 for Schematic	1
-410	984663	*HARNESS, ENGINE, CURBER - See Section 4 for Schematic	1
-420	984664	*HARNESS, PEDESTAL, CURBER - See Section 4 for Schematic	1
-430	984685	*HARNESS, FUSE BLOCK, CURBER - See Section 4 for Schematic	1

- ITEM NOT ILLUSTRATED

Section 5 ILLUSTRATED PARTS LIST

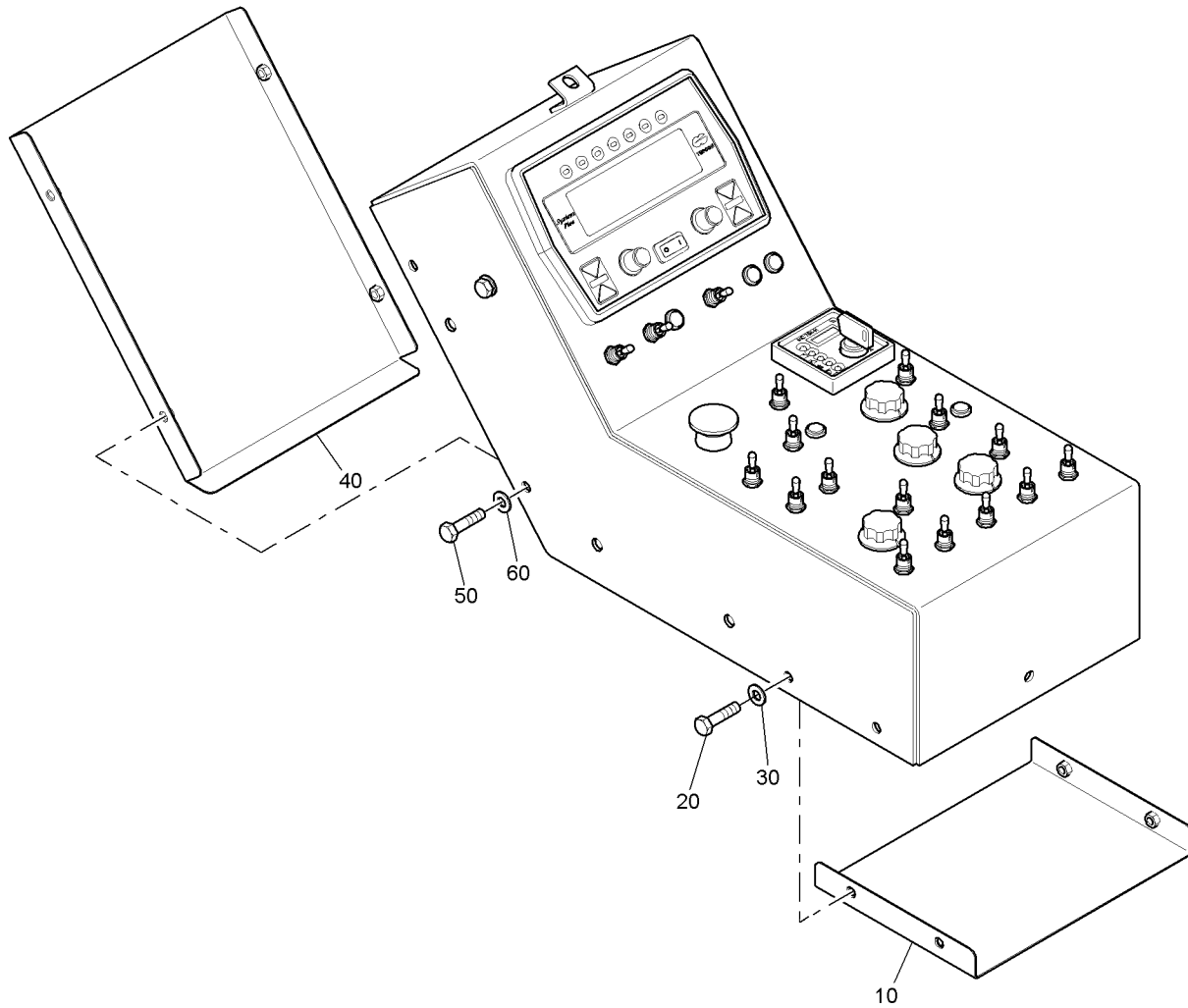

FIGURE 3. CONTROL CONSOLE (1 OF 3)



Section 5 ILLUSTRATED PARTS LIST

TABLE 3. CONTROL CONSOLE (1 OF 4)

ITEM NO.	PART NO.	DESCRIPTION	QTY.
3			
-1	987335	GROUP, CONTROL CONSOLE, CURBER (See Fig 2 for NHA)	1
10	984722	*ACCESS PANEL, BOTTOM	1
		ATTACHING PARTS	
20	102-05-1A	*CSHH, .250-20 X 1.00	4
30	118-1	*WASHER, LOCK, .250	4
		-----*	
40	984723	*ACCESS PANEL REAR	1
		ATTACHING PARTS	
50	102-05-1A	*CSHH, .250-20 X 1.00	4
60	118-1	*WASHER, LOCK, .250	4
		-----*	

- ITEM NOT ILLUSTRATED

Section 5 ILLUSTRATED PARTS LIST

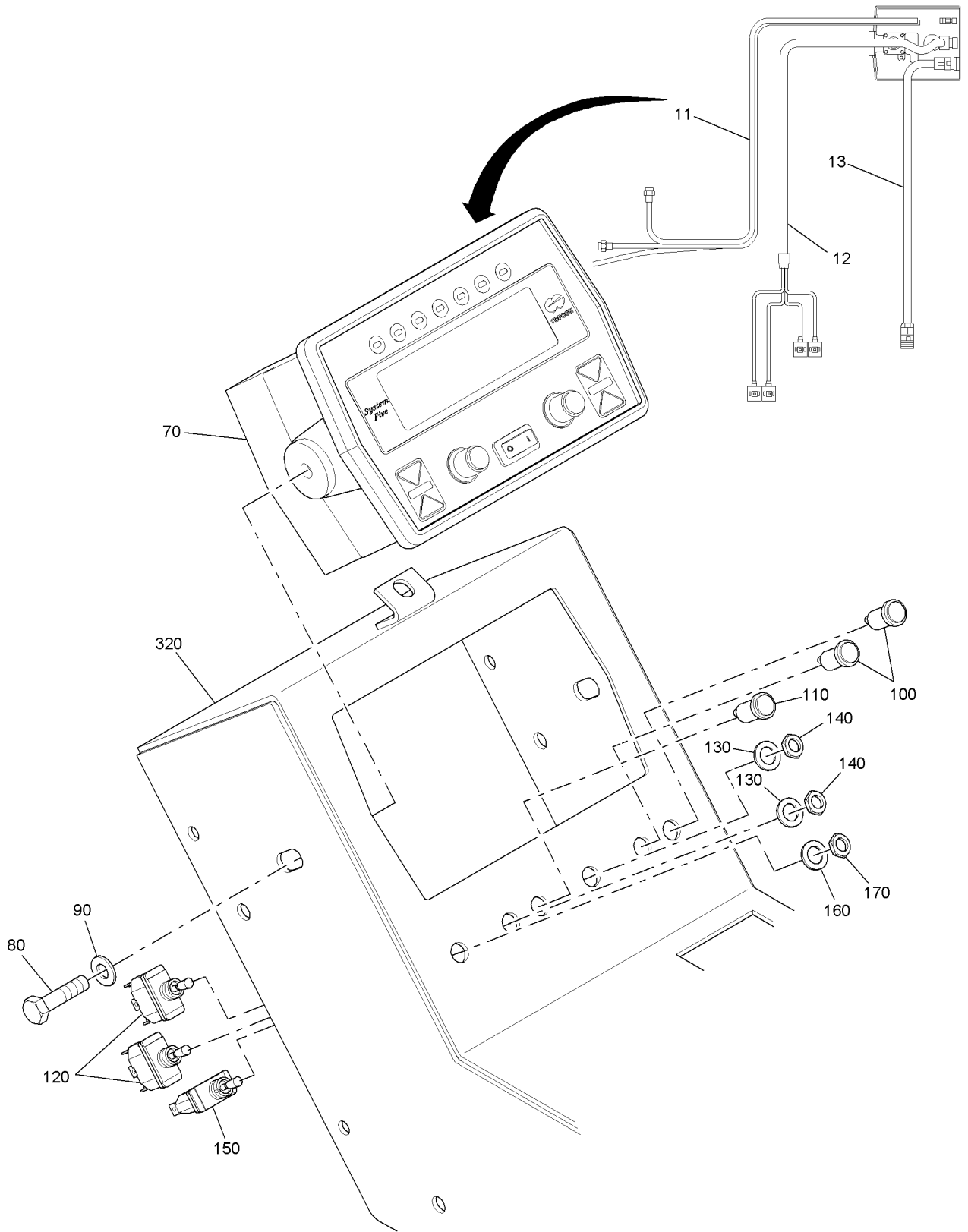

FIGURE 3. CONTROL CONSOLE (2 OF 3)



Section 5 ILLUSTRATED PARTS LIST

TABLE 3. CONTROL CONSOLE (2 OF 4)

ITEM NO.	PART NO.	DESCRIPTION	QTY.
11	984199-03	HARNESS, SLOPE SENSOR, TOPCON	1
12	984199-04	HARNESS, VALVE BLOCK, TOPCON	1
13	983414-08	HARNESS, COIL, TOPCON	1
70	984199	*KIT, CON-TEC, BASE CONTROL, TOPCON	1
		ATTACHING PARTS	
80	102-202-1A	*CSHH, .375-16 X .50, GR5	2
90	119-3	*WASHER, FLAT, SAE, .375	2
		-----*-----	
100	31986	*LIGHT, BLUE, DASH	2
110	31985	*LIGHT, GREEN, DASH	3
120	851391	*SWITCH, TOGGLE, SPST	6
		ATTACHING PARTS	
130	119-5	*WASHER, FLAT, SAE, .500	1
140	987906	*NUT, TOGGLE SWITCH	1
		-----*-----	
150	851392	*SWITCH, TOGGLE, 3-POS, SPDT	7
		ATTACHING PARTS	
160	119-5	*WASHER, FLAT, SAE, .500	1
170	987906	*NUT, TOGGLE SWITCH	1
		-----*-----	

- ITEM NOT ILLUSTRATED

Section 5 ILLUSTRATED PARTS LIST

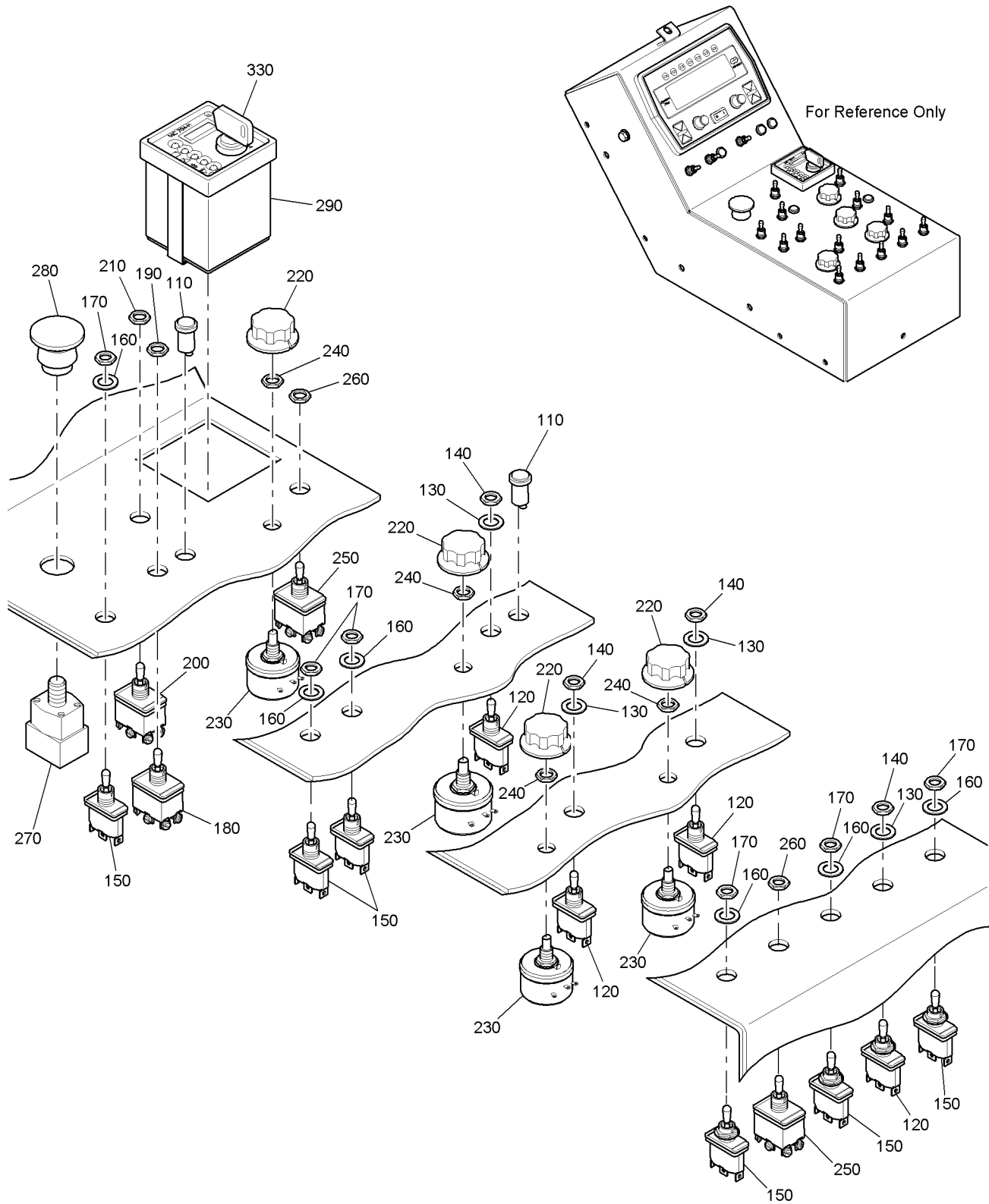

FIGURE 3. CONTROL CONSOLE (3 OF 3)



Section 5 ILLUSTRATED PARTS LIST

TABLE 3. CONTROL CONSOLE (3 OF 4)

ITEM NO.	PART NO.	DESCRIPTION	QTY.
110	31985	*LIGHT, GREEN, DASH	3
120	851391	*SWITCH, TOGGLE, SPST	6
		ATTACHING PARTS	
130	119-5	*WASHER, FLAT, SAE, .500	1
140	987906	*NUT, TOGGLE SWITCH	1
		-----*-----	
150	851392	*SWITCH, TOGGLE, 3-POS, SPDT	7
		ATTACHING PARTS	
160	119-5	*WASHER, FLAT, SAE, .500	1
170	987906	*NUT, TOGGLE SWITCH	1
		-----*-----	
180	72086	*SWITCH, TOGGLE, DPDT	1
		ATTACHING PARTS	
190	987906	*NUT, TOGGLE SWITCH	1
		-----*-----	
200	37521	*SWITCH, TOGGLE, DPDT, 3-POS	1
		ATTACHING PARTS	
210	987906	*NUT, TOGGLE SWITCH	1
		-----*-----	
220	72055	*KNOB, 0.25 SHAFT, POTENTIOMETER	4
230	72857	*POTENTIOMETER, 50 OHM, 25 WATT	4
		ATTACHING PARTS	
240	987906	*NUT, TOGGLE SWITCH	1
		-----*-----	
250	851390	*SWITCH, TOGGLE, DPDT	2
		ATTACHING PARTS	
260	987906	*NUT, TOGGLE SWITCH	1
		-----*-----	

- ITEM NOT ILLUSTRATED



Section 5 ILLUSTRATED PARTS LIST

TABLE 3. CONTROL CONSOLE (4 OF 4)

ITEM NO.	PART NO.	DESCRIPTION	QTY.
270	981507	*SWITCH, EMERGENCY STOP (Includes 981510)	1
280	981510	*KNOB, EMERGENCY SWITCH	1
290	984145	*SWITCH, IGNITION	1
-300	985385	*DECAL, CURBER PANEL, BOTTOM	1
-310	985386	*DECAL, CURBER PANEL, TOP	1
320	987308	*CONTROL PANEL, CURBER	1
330	984145-01	KEY, FOR SWITCH, IGNITION	A/R

- ITEM NOT ILLUSTRATED

Section 5 ILLUSTRATED PARTS LIST

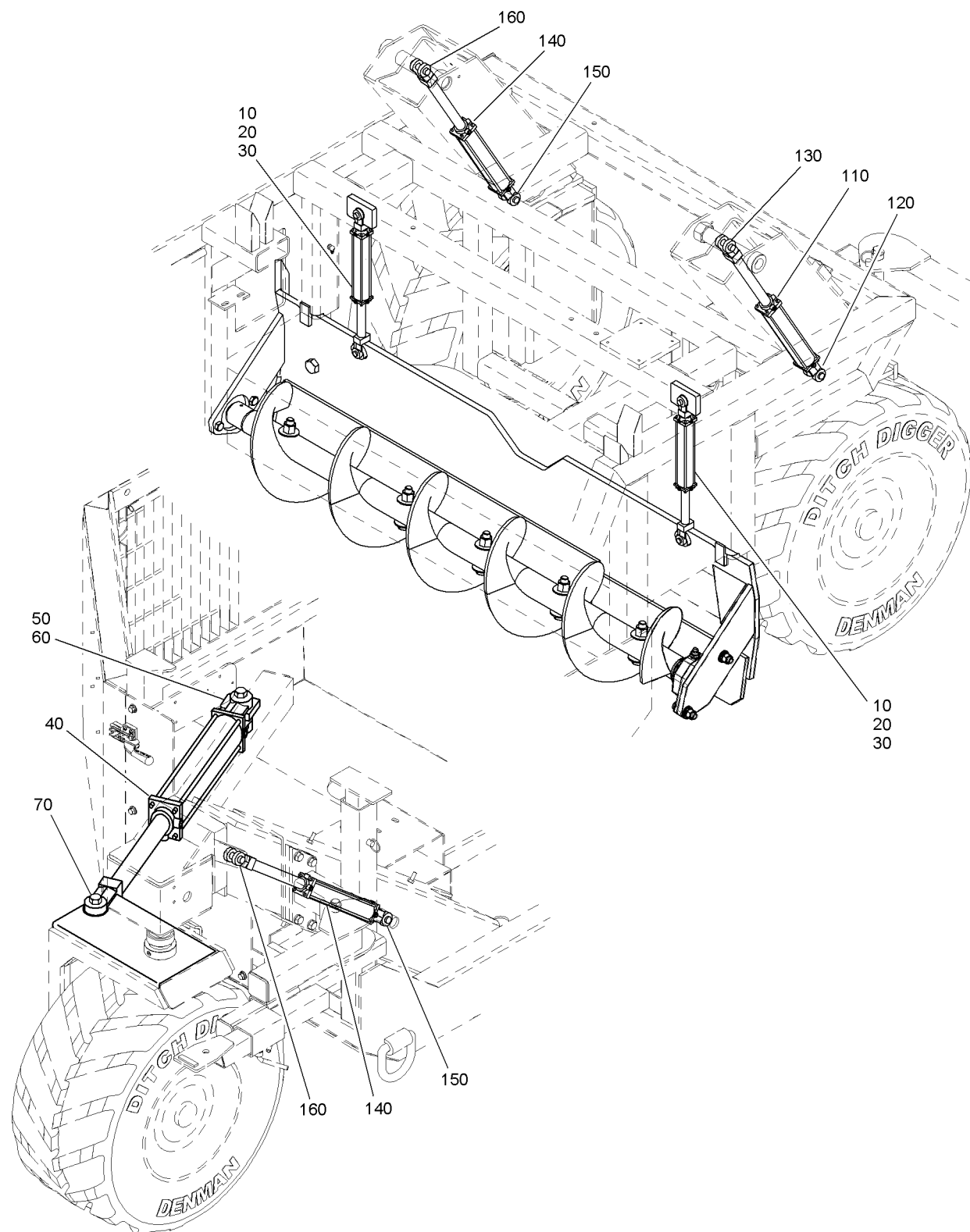

FIGURE 4. HYDRAULIC GROUP (1 OF 3)

TABLE 4. HYDRAULIC GROUP (1 OF 3)

ITEM NO.	PART NO.	DESCRIPTION	QTY.
4			
-1	987197	GROUP, HYDRAULIC (See Fig 1 for NHA)	1
10	983979	*CYLINDER, HYDRAULIC, 2.50 X 4.00 X 1.125 ROD	2
		ATTACHING PARTS	
20	210060	*PIN, CLEVIS, 1.00 X 2.625 W/1.5 HD	2
30	80336	*PIN, COTTER, .188 X 1.50	2
		-----*-----	
40	983981	*CYLINDER, HYDRAULIC, 2.50 X 16.00 X 1.125 ROD	1
		ATTACHING PARTS	
50	210060	*PIN, CLEVIS, 1.00 X 2.625 W/1.5 HD	1
60	80336	*PIN, COTTER, .188 X 1.50	1
70	100-913-1A	*CSHH, 1.00-14 X 3.00, GR5	1
		-----*-----	
110	983980	*CYLINDER, HYDRAULIC, 2.50 X 10.00 X 1.125 ROD	1
		ATTACHING PARTS	
120	81184	*CSHH, 1.00-8 X 8.00, GR5	1
130	102-921-1A	*CSHH, 1.00-8 X 5.00, GR5	1
		-----*-----	
140	985351	*CYLINDER, HYDRAULIC, 2.50 X 8.00 X 1.125 ROD	2
		ATTACHING PARTS	
150	81184	*CSHH, 1.00-8 X 8.00, GR5	1
160	102-921-1A	*CSHH, 1.00-8 X 5.00, GR5	1
		-----*-----	

- ITEM NOT ILLUSTRATED

Section 5 ILLUSTRATED PARTS LIST

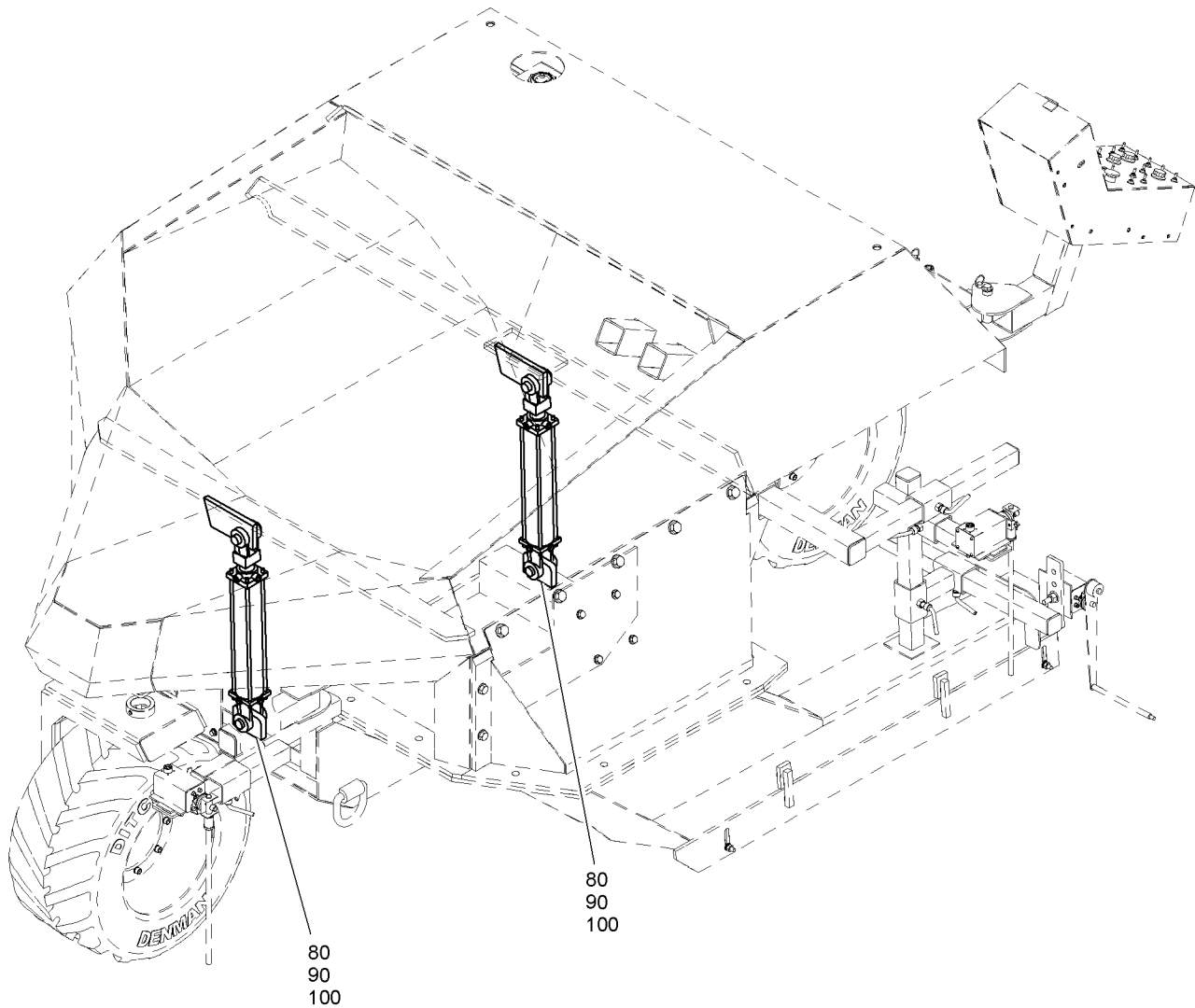

FIGURE 4. HYDRAULIC GROUP (2 OF 3)



Section 5 ILLUSTRATED PARTS LIST

TABLE 4. HYDRAULIC GROUP (2 OF 3)

ITEM NO.	PART NO.	DESCRIPTION	QTY.
80	870091	*CYLINDER, HYDRAULIC, 2.50 X 12.00 X 1.125 ROD	2
		*ATTACHING PARTS	
90	210060	*PIN, CLEVIS, 1.00 X 2.625 W/1.5 HD	2
100	80336	*PIN, COTTER, .188 X 1.50	2
		-----*	

- ITEM NOT ILLUSTRATED

Section 5 ILLUSTRATED PARTS LIST

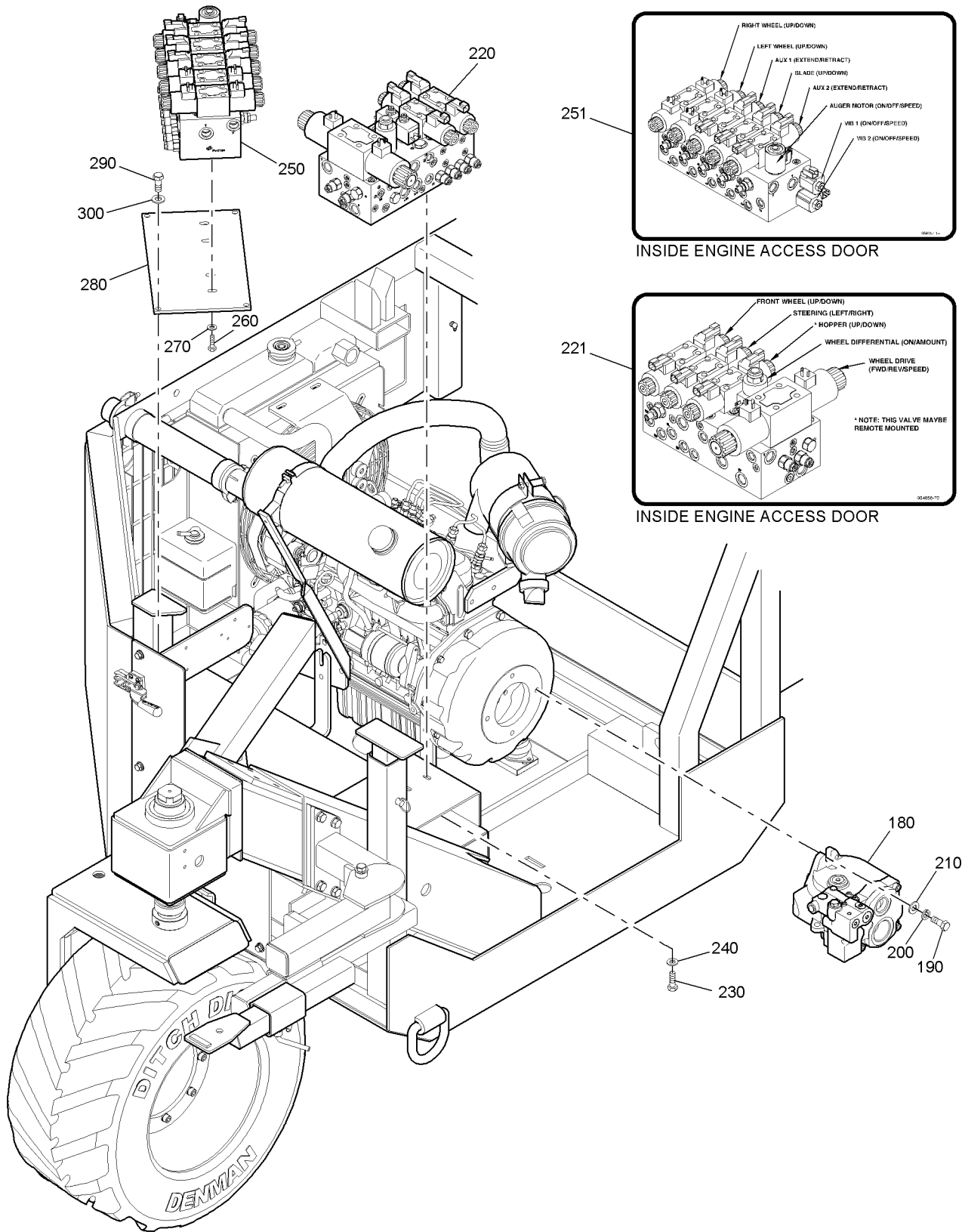

FIGURE 4. HYDRAULIC GROUP (3 OF 3)

TABLE 4. HYDRAULIC GROUP (3 OF 3)

ITEM NO.	PART NO.	DESCRIPTION	QTY.
-170	984081	*VIBRATOR, HYD, CURVED (See Fig 8 for Breakdown)	1
180	984655	*PUMP, HYDRAULIC	1
		ATTACHING PARTS	
190	102-406-1A	*CSHH, .500-13 X 1.250, GR5	2
200	118-5	*WASHER, LOCK, .500	2
210	119-5	*WASHER, FLAT, SAE, .500	2
		-----*-----	
220	984656	*VALVE, HYDRAULIC, DRIVE MANIFOLD (See Fig 5 for Breakdown)	1
221	984656-23	*DECAL, CURBER, HYD DRIVE (Inside Engine Access Door)	1
		ATTACHING PARTS	
230	102-205-1A	*CSHH, .375-16 X 1.00, GR5	4
240	118-3	*WASHER, LOCK, .375	4
		-----*-----	
250	984657	*VALVE, HYDRAULIC, MANIFOLD, REAR (See Fig 6 for Breakdown)	1
251	984657-14	*DECAL, VLV, CURBER ACCESSORY (Inside Engine Access Door)	1
		ATTACHING PARTS	
260	102-205-1A	*CSHH, .375-16 X 1.00, GR5	4
270	119-3	*WASHER, FLAT, SAE, .375	4
		-----*-----	
280	987330	*PLATE, REAR MANIFOLD	1
		ATTACHING PARTS	
290	102-305-1A	*CSHH, .375-16 X 1.00, GR5	4
300	118-3	*WASHER, LOCK, .375	4
		-----*-----	
-310	987088	*VIBRATOR, HYD, STR (See Fig 8 for Breakdown)	1
-320	987199	*KIT, FITT/HOSE, CURBER	1

- ITEM NOT ILLUSTRATED

Section 5 ILLUSTRATED PARTS LIST

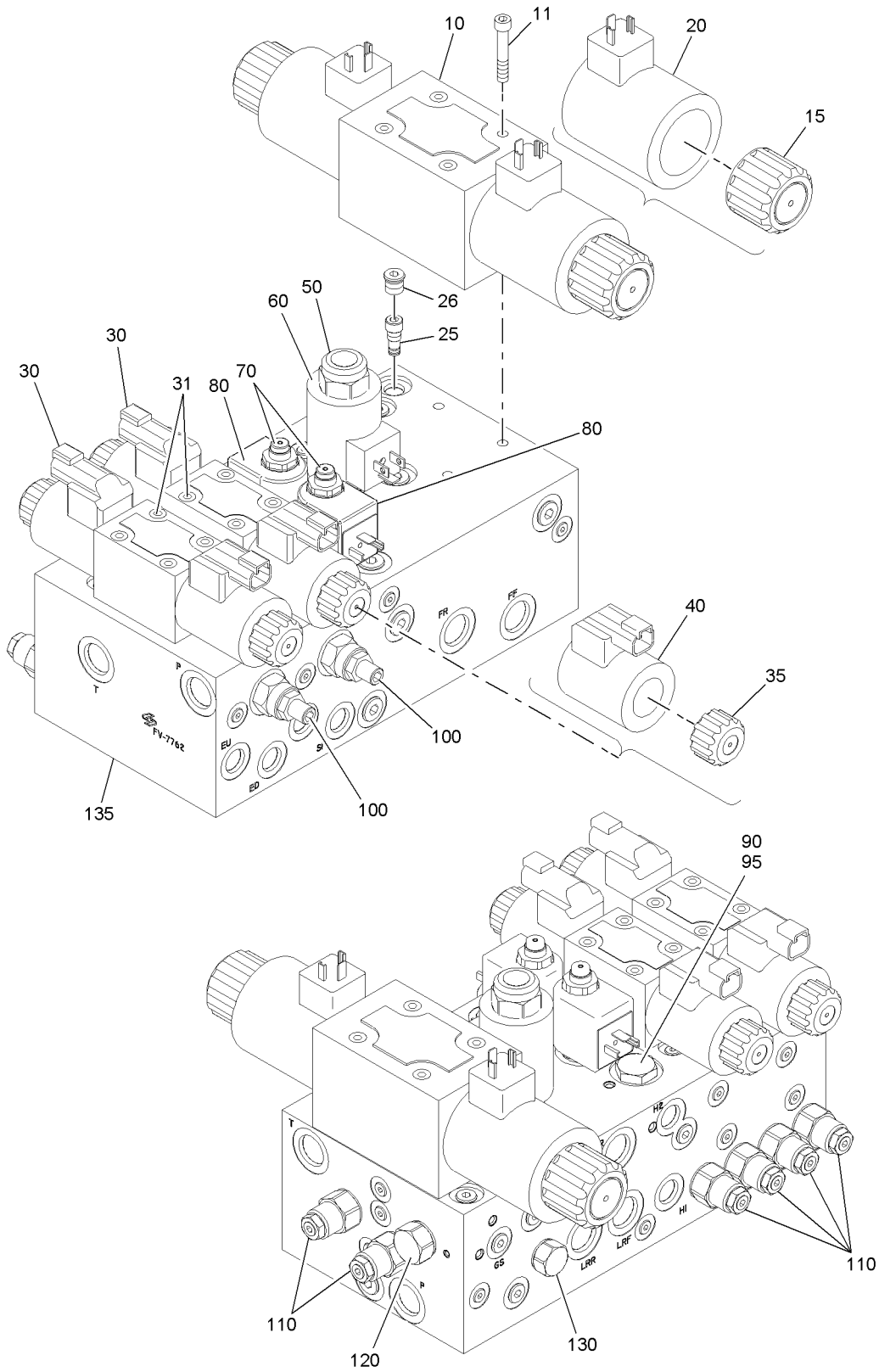

FIGURE 5. VALVE ASSEMBLY

TABLE 5. VALVE ASSEMBLY

ITEM NO.	PART NO.	DESCRIPTION	QTY.
5			
-1	984656	VALVE, HYD, DRIVE MANIFOLD (See Fig 4 for NHA)	1
10	984656-11	*D05 PROPORTIONAL DCV	1
11	984656-22	**CSSH, 25-20 X 1.50	4
15	984656-24	**NUT, KNULE, D05 VALVE	2
20	984656-26	**COIL, D05 VALVE	2
25	984656-10	*VLV, SHUTTLE	1
26	984656-17	**PLUG, SAE04	1
30	984656-06	*VLV, D03 SOLENOID	2
31	984656-18	**CSSH, 10-24 X 1.75	8
35	984656-25	**NUT, KNULE, D03 VALVE	4
40	984656-27	**COIL, SOLENOID VALVE	4
50	984656-13	*VLV, BI-DIR. PROPORTIONAL FLOW CONTROL	1
-55	984656-28	**NUT, HEX, COIL ZL70	2
60	984656-14	**COIL, CURBER MANIFOLD	2
70	984656-04	*VLV, SOLENOID	2
-75	984657-15	**NUT, HEX, SOLENOID COIL	4
80	984656-12	**COIL, VLV, 12 VDC DIN, CURBER MANIFOLD	4
90	984656-07	*VLV, CHECK	1
95	984656-08	*PISTON, SINGLE PILOT	1
100	984656-05	*VLV, NEEDLE	2
110	984656-02	*VLV, COUNTERBALANCE	6
120	984656-09	*ELEMENT, LOGIC, N.O.	1
130	984656-03	*FLOW DIVIDER/COMBINER	1
135	984656-01	*VALVE BODY	1
-140	984656-15	*PLUG, SAE02	20
-150	984656-16	*PLUG, SAE06	9
-160	984656-17	*PLUG, SAE04	5
-170	984656-19	*PLUG, MB700-070	4
-180	984656-20	*ORIFICE, REMOVABLE	2
-190	984656-21	*PLUG, 5MM EXPANSION	1

- ITEM NOT ILLUSTRATED

Section 5 ILLUSTRATED PARTS LIST

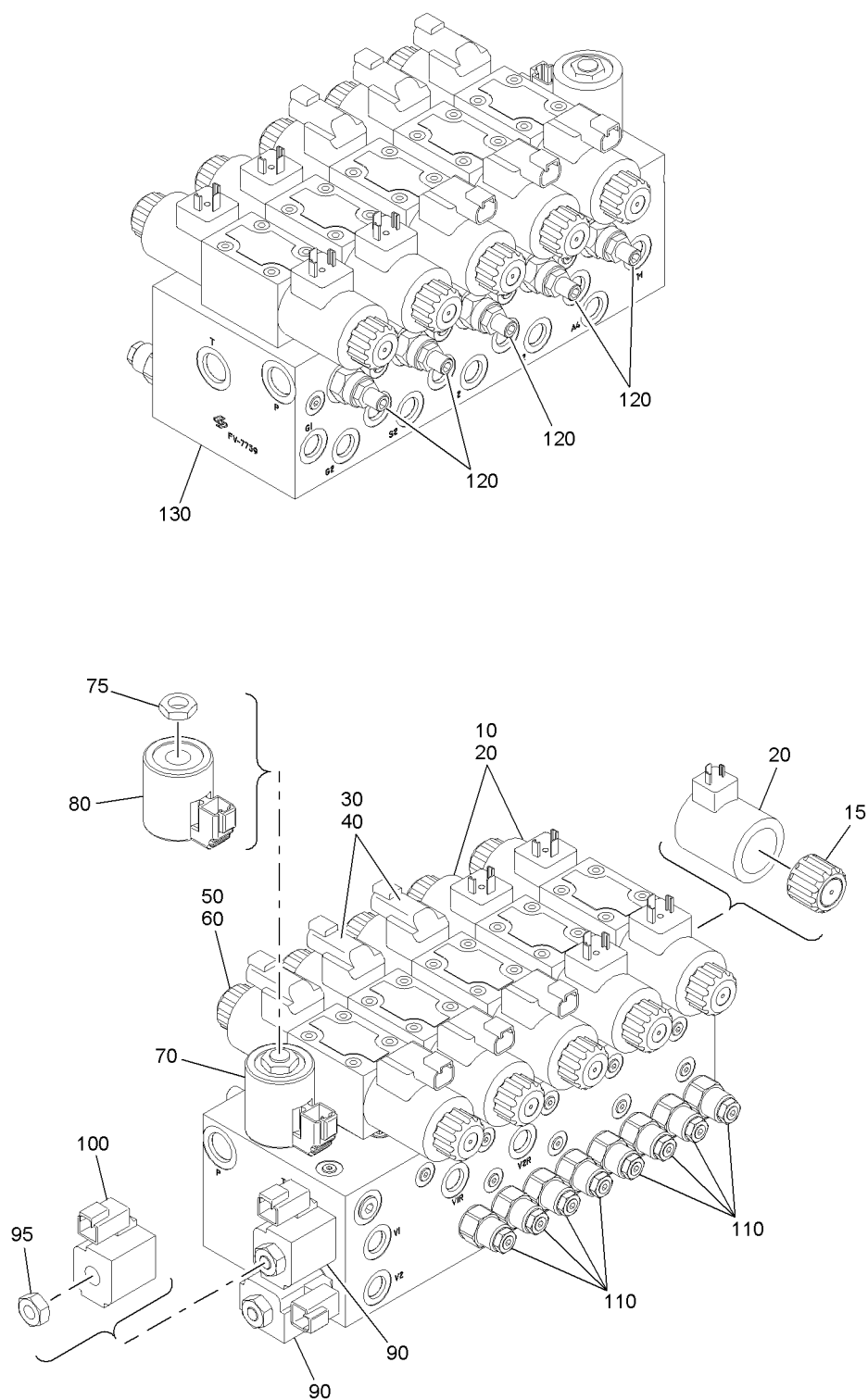

FIGURE 6. VALVE ASSEMBLY, REAR MANIFOLD

TABLE 6. VALVE ASSEMBLY, REAR MANIFOLD

ITEM NO.	PART NO.	DESCRIPTION	QTY.
6			
-1	984657	VALVE, HYD, MANIFOLD, REAR (See Fig 4 for NHA)	1
10	984657-08	*VLV, D03 PROPORTIONAL	2
-11	984657-11	**CSSH, 10-24 X 1.75	8
15	984656-25	**NUT, KNULE, D03 VALVE	4
20	984657-16	**COIL, SOLENOID, D03, PROPORTIONAL	4
30	984657-10	*VLV, D03 SOLENOID	2
-31	984657-11	**CSSH, 10-24 X 1.75	8
-35	984656-25	**NUT, KNULE, D03 VALVE	4
40	984656-27	**COIL, SOLENOID VALVE	4
50	984657-10	*VLV, D03 SOLENOID	1
-51	984657-11	**CSSH, 10-24 X 1.75	4
-55	984656-25	**NUT, KNULE, D03 VALVE	2
60	984656-27	**COIL, SOLENOID VALVE	2
70	984657-05	*VLV, SOLENOID	1
75	984657-15	**NUT, HEX, SOLENOID COIL	2
80	984657-07	**COIL, 12 VDC W/DEUTSCH CONNECTORS	2
90	984657-04	*CONTROL, FLOW, NORM CLOSED PROP	2
95	984657-15	**NUT, HEX, SOLENOID COIL	4
100	984657-06	**COIL, 12 VDC DEUTSCH	4
110	984657-02	*VLV, COUNTERBALANCE	8
120	984657-03	*VLV, NEEDLE	5
130	984657-01	*VALVE BODY	1
-140	984657-12	*PLUG, SAE06	1
-150	984657-13	*PLUG, SAE02	24

- ITEM NOT ILLUSTRATED

Section 5 ILLUSTRATED PARTS LIST

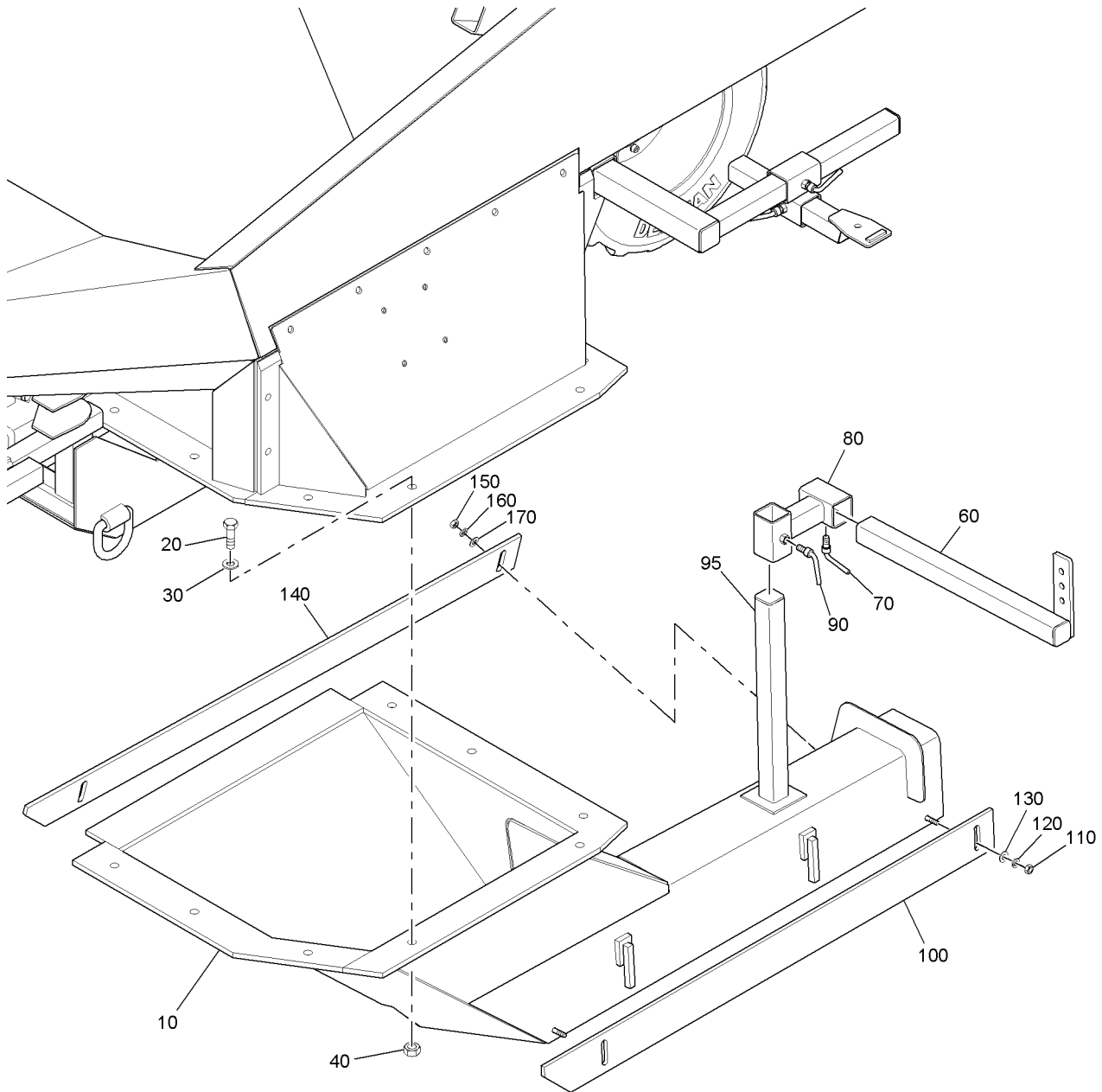

FIGURE 7. MOLD GROUP

TABLE 7. MOLD GROUP

ITEM NO.	PART NO.	DESCRIPTION	QTY.
7			
-1	986878-06	GROUP, MOLD, CURBER (See Fig 1 for NHA)	1
10	987406	*STANDARD MOLD	1
		ATTACHING PARTS	
20	102-607-1A	*CSHH, .625-11 X 1.50, GR5	8
30	118-7	*WASHER, LOCK, .625	8
40	116-7	*NUT, HEX, .625-11	8
		-----*-----	
-50	987409	*GROUP, ATTACH ARM	1
60	987429	**HORIZONTAL, ATTACH, ARM	1
70	984740	**LOCK, ARM, W/M	1
80	987373	**CONNECT, SENSOR COVER	1
90	984740	**LOCK, ARM, W/M	1
95	987415	**ATTACH, VERT. ARM, W/M	1
100	987412	*SLIDE, MOLD FRONT	1
		ATTACHING PARTS	
110	115-3	*NUT, HEX, .375-24	2
120	118-3	*WASHER, LOCK, .375	2
130	119-3	*WASHER, FLAT, SAE, .375	2
		-----*-----	
140	987413	SLIDE, MOLD BACK	1
		ATTACHING PARTS	
110	115-3	*NUT, HEX, .375-24	2
120	118-3	*WASHER, LOCK, .375	2
130	119-3	*WASHER, FLAT, SAE, .375	2
		-----*-----	

- ITEM NOT ILLUSTRATED

Section 5 ILLUSTRATED PARTS LIST

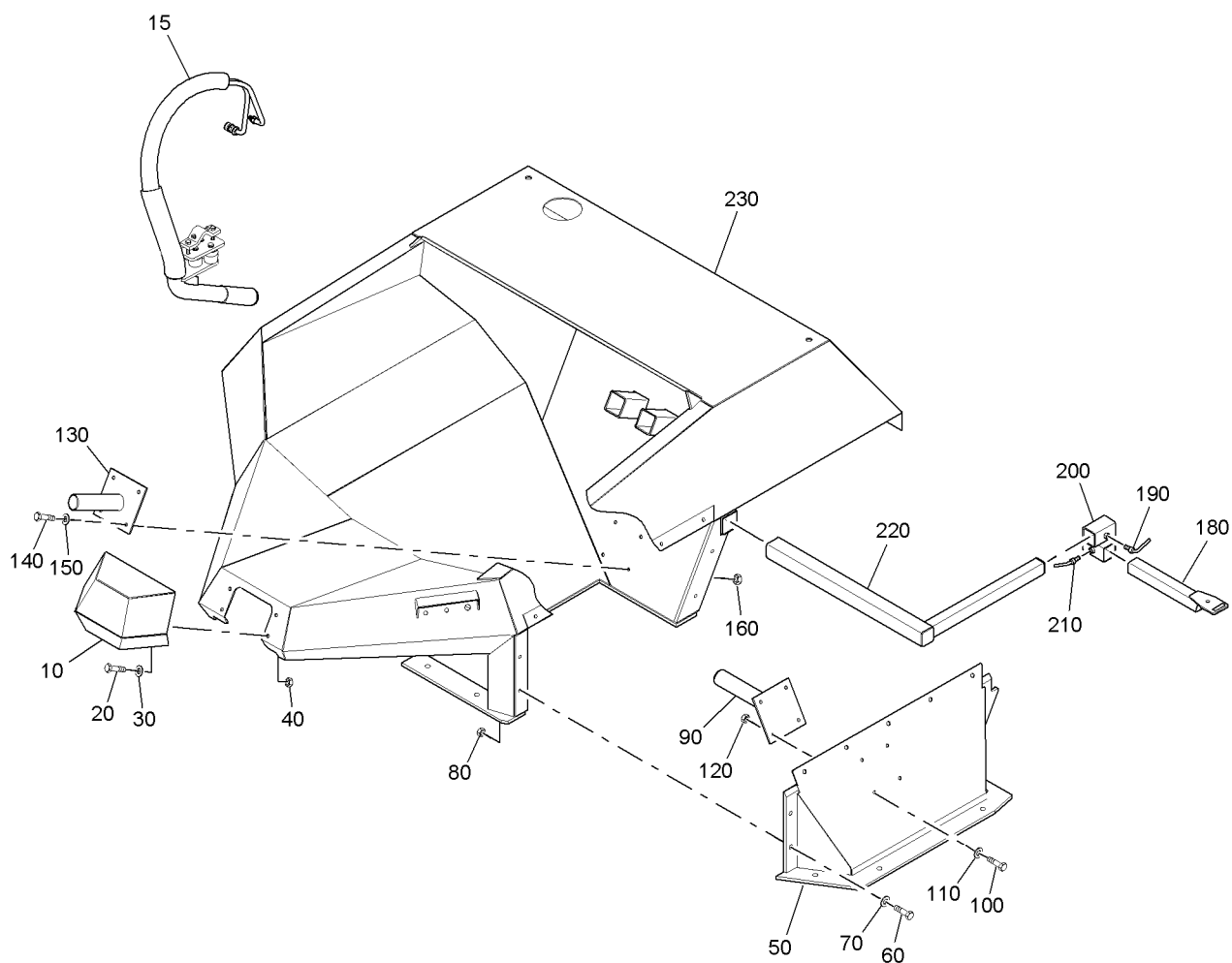

FIGURE 8. COVER GROUP

TABLE 8. COVER GROUP

ITEM NO.	PART NO.	DESCRIPTION	QTY.
8			
-1	987344	GROUP, COVER, CURBER (See Fig 1 for NHA)	1
10	987275	*GROUP, NOSE COVER	1
15	984081	*VIBRATOR, HYD, CURVED, 10,500 VPM (Part of Hyd Grp)	REF
-16	987088	*VIBRATOR, HYD, STR, 10,500 VPM (Part of Hyd Grp)	REF
20	102-105-1A	*CSHH, .312-18 X 1.00, GR5	2
30	118-2	*WASHER, LOCK, .312	2
40	116-2	*NUT, HEX, .312-18	2
		-----*-----	
50	985259	*PANEL, EXTENSION, HOPPER	1
		ATTACHING PARTS	
60	102-405-1A	*CSHH, .500-13 X 1.00, GR5	9
70	118-5	*WASHER, LOCK, .500	9
80	116-5	*NUT, HEX, .500-13	9
		-----*-----	
90	985266	*MOUNT, VIBRATOR, ANGLE	1
		ATTACHING PARTS	
100	102-203-1A	*CSHH, .375-16 X .75, GR5	4
110	118-3	*WASHER, LOCK, .375	4
120	116-3	*NUT, HEX, .375-16	4
		-----*-----	
130	984076	*MOUNTING BRACKET, W/M	1
		ATTACHING PARTS	
140	102-203-1A	*CSHH, .375-16 X .75, GR5	4
150	118-3	*WASHER, LOCK, .375	4
160	116-3	*NUT, HEX, .375-16	4
		-----*-----	
-170	987369	*GROUP, SENSOR ARM COVER	1
180	985932	**FRONT, STRINGLINE SENSOR, MOUNTING ARM	1
190	984740	**LOCK, ARM, W/M	1
200	987509	**CONNECT SENSOR, W/M	1
210	984740	**LOCK, ARM, W/M	1
220	987370	**ARM1, SENSOR COVER, W/M	1
230	983703	*TOP, COVER/CHUTE, W/M	1

- ITEM NOT ILLUSTRATED

Section 5 ILLUSTRATED PARTS LIST

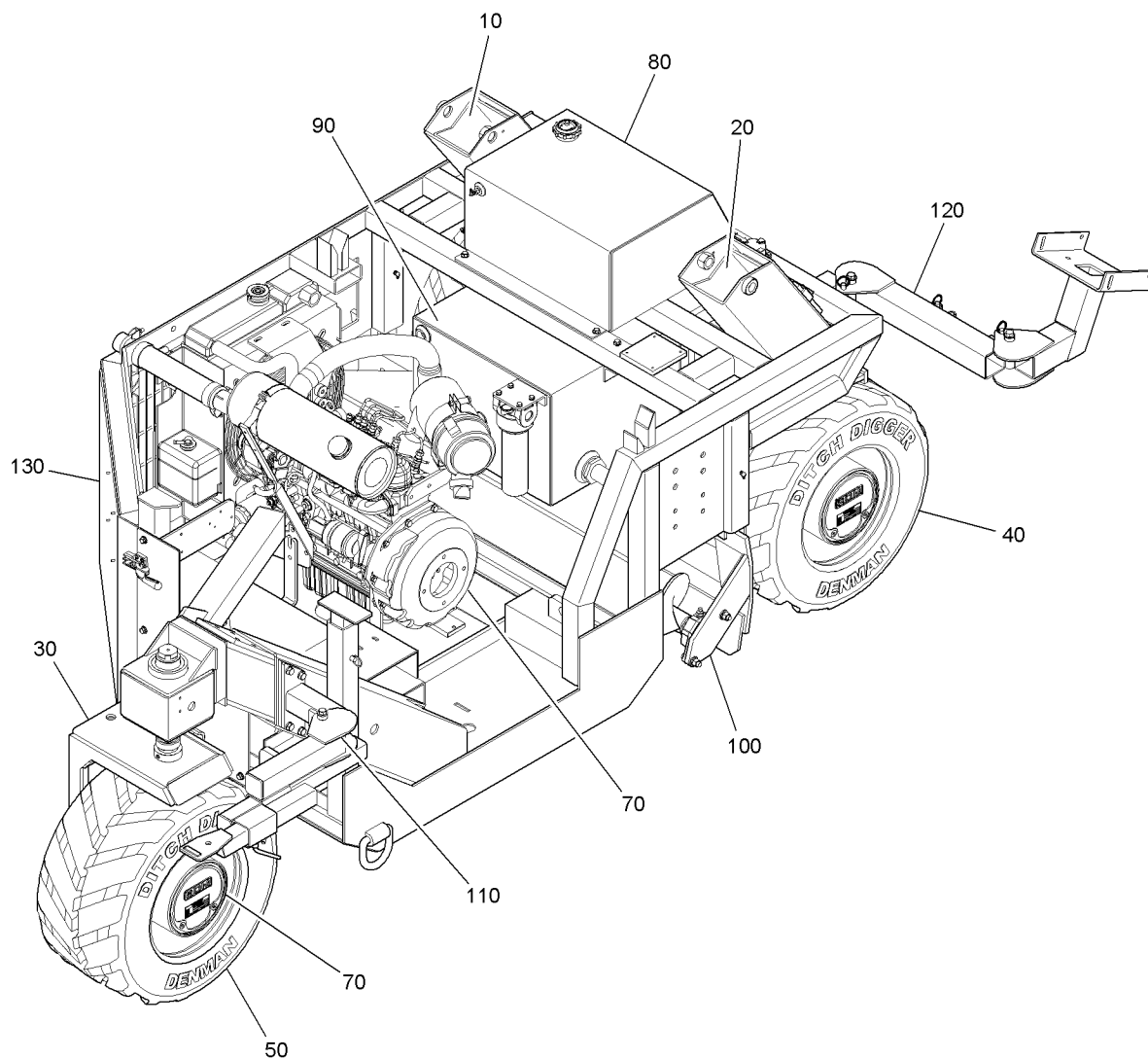

FIGURE 9. FRAME ASSEMBLY

TABLE 9. FRAME ASSEMBLY

ITEM NO.	PART NO.	DESCRIPTION	QTY.
9			
-1	984190	GROUP, FRAME, CURBER (See Fig 1 for NHA)	1
10	983819	GROUP, WHEEL LIFT, RIGHT REAR (See Fig 10 for Breakdown)	1
20	983820	GROUP, WHEEL LIFT, LEFT REAR (See Fig 10 for Breakdown)	1
30	983821	GROUP, WHEEL LIFT, FRONT (See Fig 11 for Breakdown)	1
40		GROUP, LEFT REAR TIRE, WHEEL AND TORQUE HUB (See Fig 12 for Breakdown)	1
50		GROUP, RIGHT REAR TIRE, WHEEL AND TORQUE HUB (See Fig 13 for Breakdown)	1
60		GROUP, FRONT TIRE, WHEEL AND TORQUE HUB (See Fig 14 for Breakdown)	1
70	984157	GROUP, ENGINE, KUBOTA (See Fig 15 for Breakdown)	1
80	984780	GROUP, FUEL TANK (See Fig 17 for Breakdown)	1
90	984778	GROUP, HYDRAULIC TANK (See Fig 18 for Breakdown)	1
100	985319	GROUP, AUGER (See Fig 19 for Breakdown)	1
110	985370	GROUP, SENSOR ARM (See Fig 20 for Breakdown)	1
120		GROUP, CONTROL PEDESTAL & TOW RING (See Fig 21 for Breakdown)	1
130		GROUP, ACCESS DOOR AND COVER (See Fig 22 for Breakdown)	2

- ITEM NOT ILLUSTRATED

Section 5 ILLUSTRATED PARTS LIST

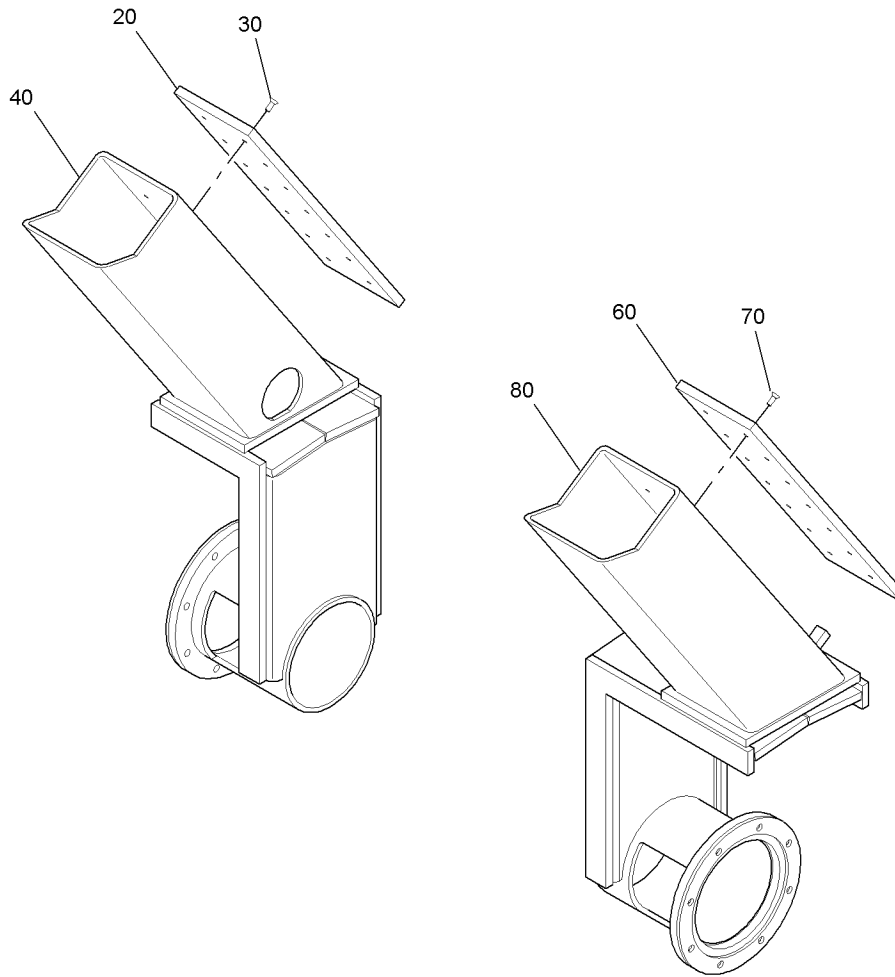

FIGURE 10. LEFT AND RIGHT WHEEL LIFT GROUP



Section 5 ILLUSTRATED PARTS LIST

TABLE 10. LEFT AND RIGHT WHEEL LIFT GROUP

ITEM NO.	PART NO.	DESCRIPTION	QTY.
10			
-1		LEFT AND RIGHT WHEEL LIFT GROUP	
-10	983819	GROUP, WHEEL LIFT, RIGHT REAR (See Fig 9 for NHA)	1
20	983872	*WEAR PLATE, REAR WHEEL LIFT	1
		ATTACHING PARTS	
30	81238	*CSFHS, .250-20 X 1.00	14
		-----*-----	
40	983875	*WHEEL LIFT, RIGHT REAR, W/M	1
-50	983820	GROUP, WHEEL LIFT, LEFT REAR (See Fig 9 for NHA)	1
60	983872	*WEAR PLATE, REAR WHEEL LIFT	1
		ATTACHING PARTS	
70	81238	*CSFHS, .250-20 X 1.00	14
		-----*-----	
80	983886	*WHEEL LIFT, LEFT REAR, W/M	1

- ITEM NOT ILLUSTRATED

Section 5 ILLUSTRATED PARTS LIST

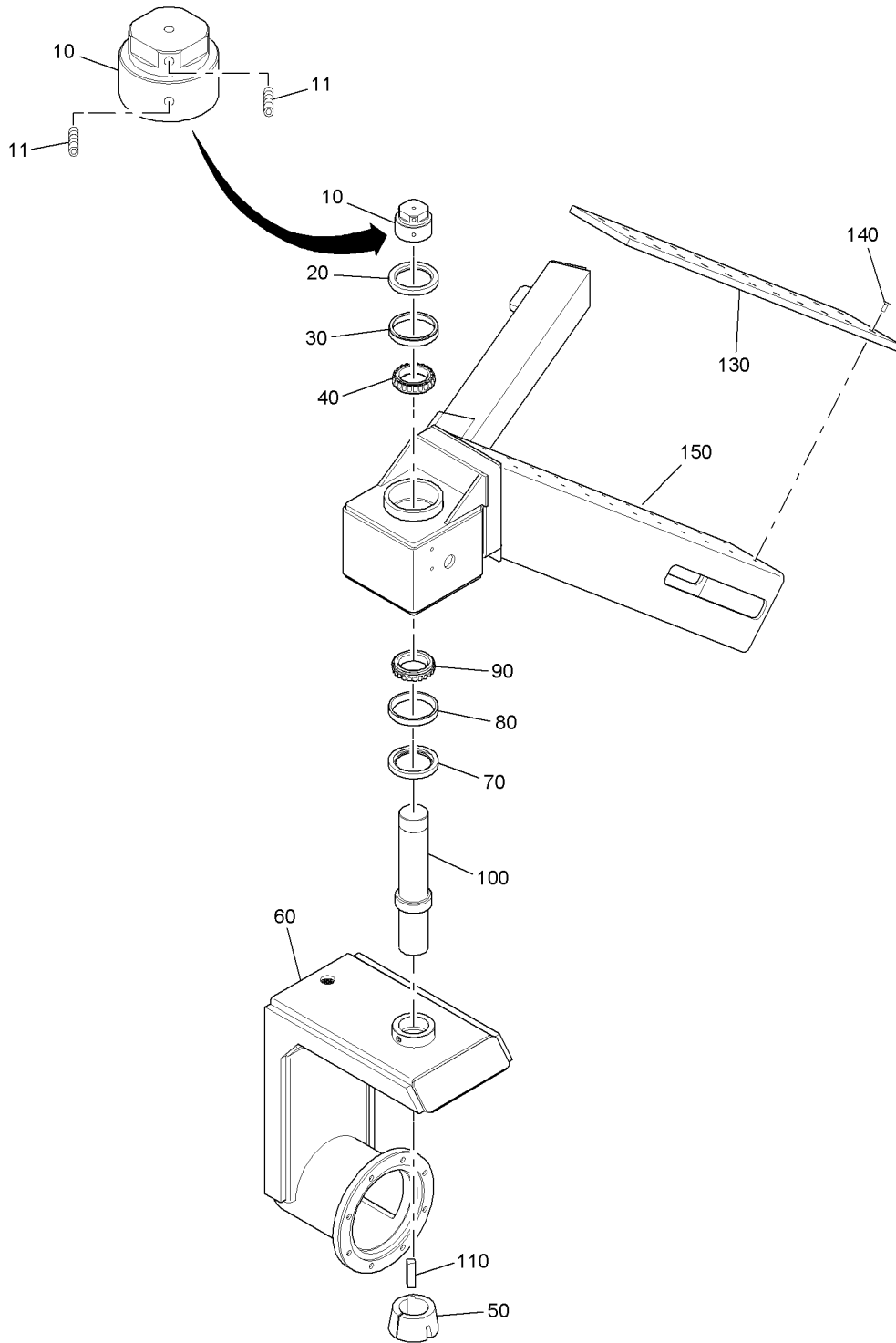

FIGURE 11. WHEEL LIFT, FRONT

TABLE 11. WHEEL LIFT, FRONT

ITEM NO.	PART NO.	DESCRIPTION	QTY.
11			
-1	983821	GROUP, WHEEL LIFT, FRONT (See Fig 9 for NHA)	1
10	987130	*SPINDLE NUT, MODIFIED	1
11	80392	*SET SCREW, .250-20 X .500	2
20	210240	*SEAL	1
30	210190	*BEARING CUP	1
40	210180	*BEARING CONE	1
50	983894	*BUSHING, TAPER, FRONT WHEEL LIFT	1
60	983914	*FOOT, WHEEL LIFT, FRONT, W/M	1
70	210240	*SEAL	1
80	210190	*BEARING CUP	1
90	210180	*BEARING CONE	1
100	987131	*STEERING PIN, FRONT WHEEL LIFT	1
110	129-413	*KEYSTOCK, SQ, 0.500 X 2.00	1
-120	300109	*HOUSING, YOKE SHAFT	1
130	983891	*WEAR PLATE, FRONT WHEEL LIFT	1
		ATTACHING PARTS	
140	102-7-1A	*CSHH, .250-20 X 1.50,GR5	22
		-----*-----	
150	983895	*WHEEL LIFT, FRONT	1

- ITEM NOT ILLUSTRATED

Section 5 ILLUSTRATED PARTS LIST

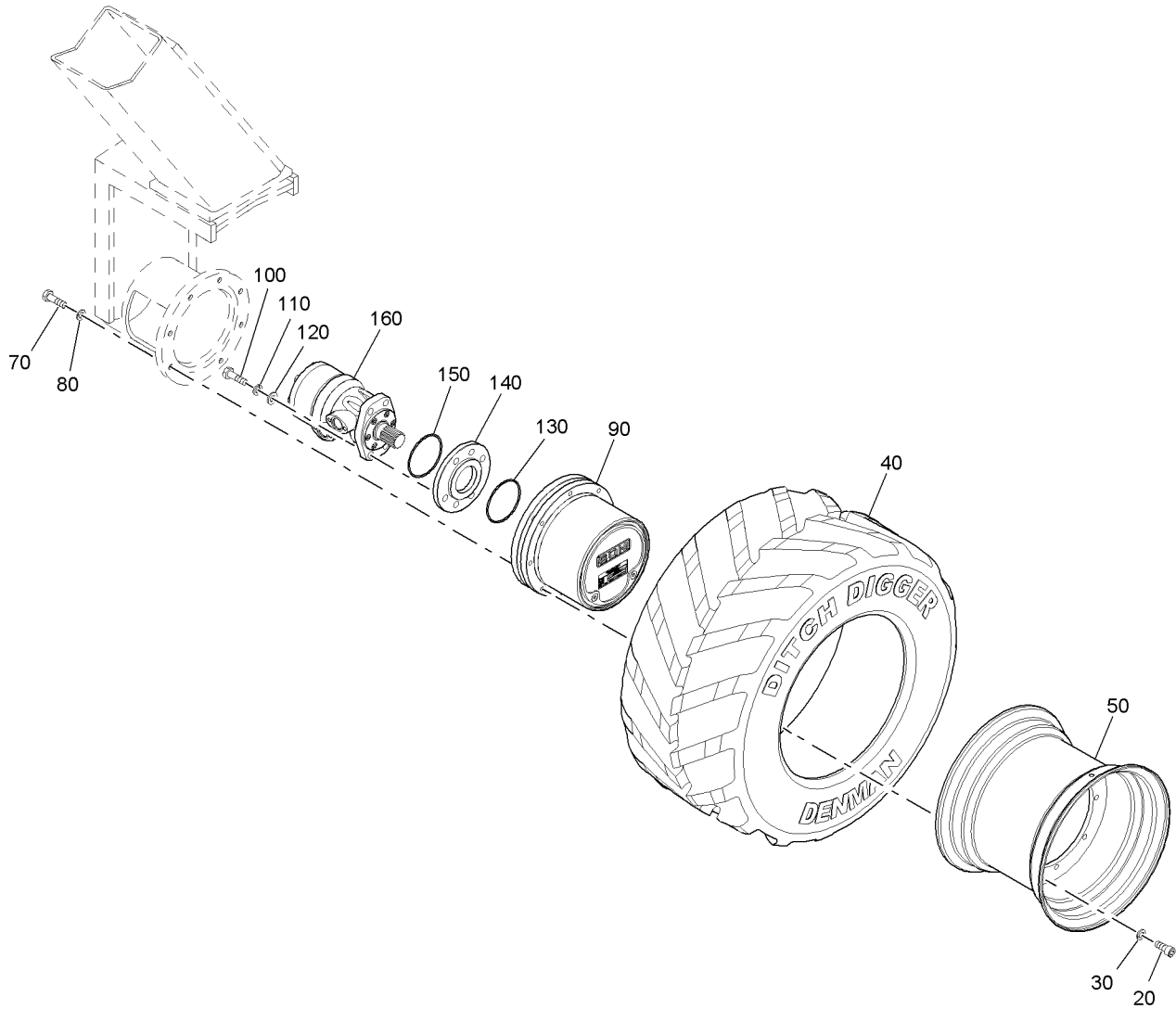

FIGURE 12. LEFT REAR TIRE, WHEEL & TORQUE HUB

TABLE 12. LEFT REAR TIRE, WHEEL & TORQUE HUB

ITEM NO.	PART NO.	DESCRIPTION	QTY.
12			
-1		LEFT REAR TIRE, WHEEL AND TORQUE HUB (See Fig 9 for NHA)	
-10	984131	GROUP, TIRE AND WHEEL LEFT	1
		ATTACHING PARTS	
20	80516	*CSHH, M10-1.50 X 30MM	8
30	118-M10	*WASHER, LOCK, 10MM	8
		-----*	
40	984034	*TIRE, DITCH DIGGER (Not Sold Separately)	REF
50	984035	*STANDARD WHEEL (Not Sold Separately)	REF
-60	984733	GROUP, TORQUE HUB/MOTOR	3
		ATTACHING PARTS	
70	80516	*CSHH, M10-1.50 X 30MM	8
80	118-M10	*WASHER, LOCK, 10MM	8
		-----*	
90	983873	*TORQUE HUB, 6.09:1, COMER	1
		ATTACHING PARTS	
100	80990	*CSHH, M10-1.50 X 35MM	4
110	118-M10	*WASHER, LOCK, 10MM	4
120	80474	*WASHER, FLAT, M10	4
		-----*	
130	984753	*SEAL, O-RING	1
140	984732	*PLATE, SPACER, TORQUE HUB	1
150	984753	*SEAL, O-RING	1
160	985382	*MOTOR, HYD, DRIVE, CURBER	1

- ITEM NOT ILLUSTRATED

Section 5 ILLUSTRATED PARTS LIST

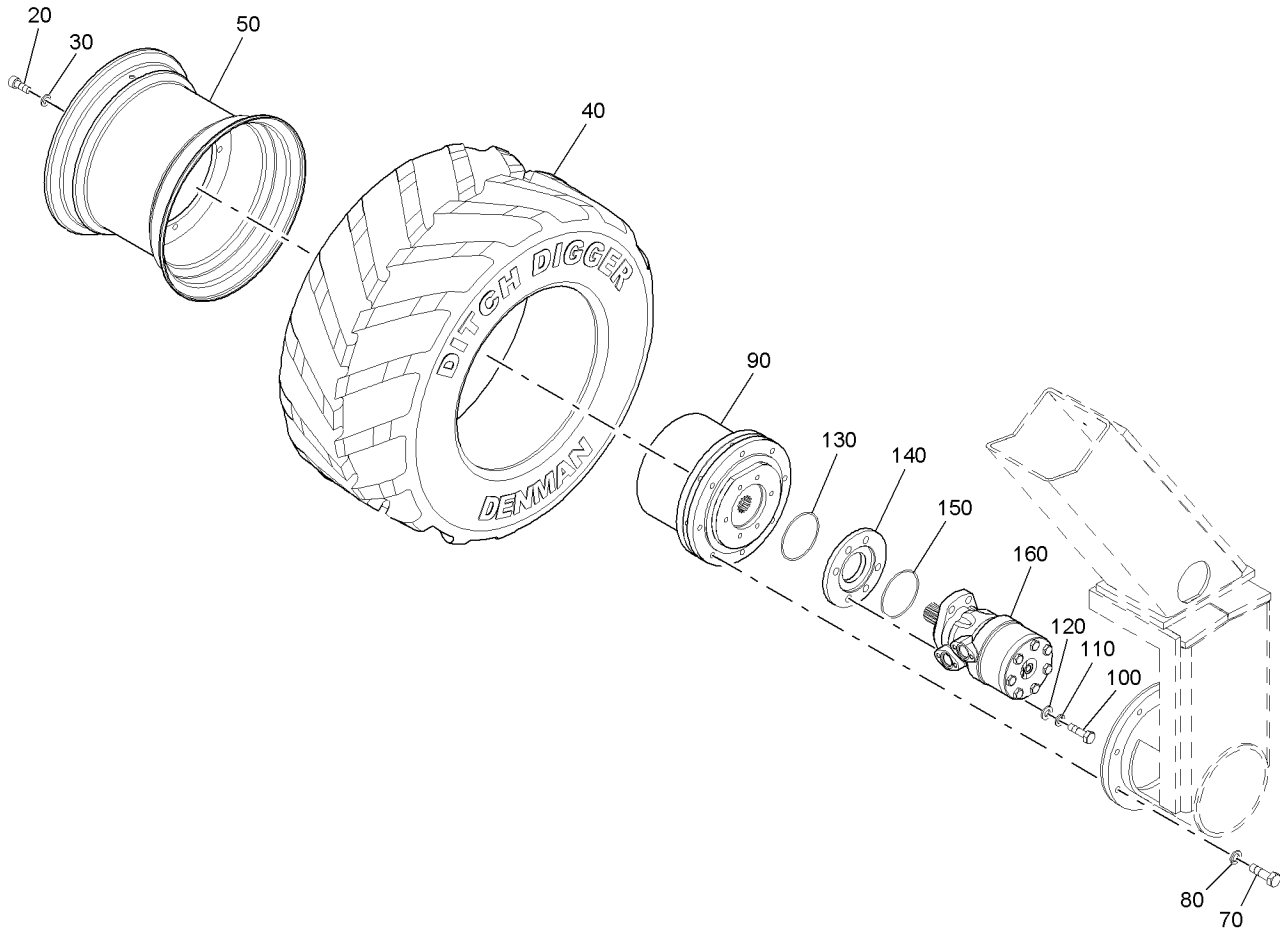

FIGURE 13. RIGHT REAR TIRE & WHEEL & TORQUE HUB

TABLE 13. RIGHT REAR TIRE & WHEEL & TORQUE HUB

ITEM NO.	PART NO.	DESCRIPTION	QTY.
13			
-1		RIGHT REAR TIRE, WHEEL AND TORQUE HUB (See Fig 9 for NHA)	
-10	984033	GROUP, TIRE AND WHEEL RIGHT	1
		ATTACHING PARTS	
20	80516	*CSHH, M10-1.50 X 30MM	8
30	118-M10	*WASHER, LOCK, 10MM	8
		-----*	
40	984034	*TIRE, DITCH DIGGER (Not Sold Separately)	REF
50	984035	*STANDARD WHEEL (Not Sold Separately)	REF
-60	984733	GROUP, TORQUE HUB/MOTOR	3
		ATTACHING PARTS	
70	80516	*CSHH, M10-1.50 X 30MM	8
80	118-M10	*WASHER, LOCK, 10MM	8
		-----*	
90	983873	*TORQUE HUB, 6.09:1, COMER	1
		ATTACHING PARTS	
100	80990	*CSHH, M10-1.50 X 35MM	4
110	118-M10	*WASHER, LOCK, 10MM	4
120	80474	*WASHER, FLAT, M10	4
		-----*	
130	984753	*SEAL, O-RING	1
140	984732	*PLATE, SPACER, TORQUE HUB	1
150	984753	*SEAL, O-RING	1
160	985382	*MOTOR, HYD, DRIVE, CURBER	1

- ITEM NOT ILLUSTRATED

Section 5 ILLUSTRATED PARTS LIST

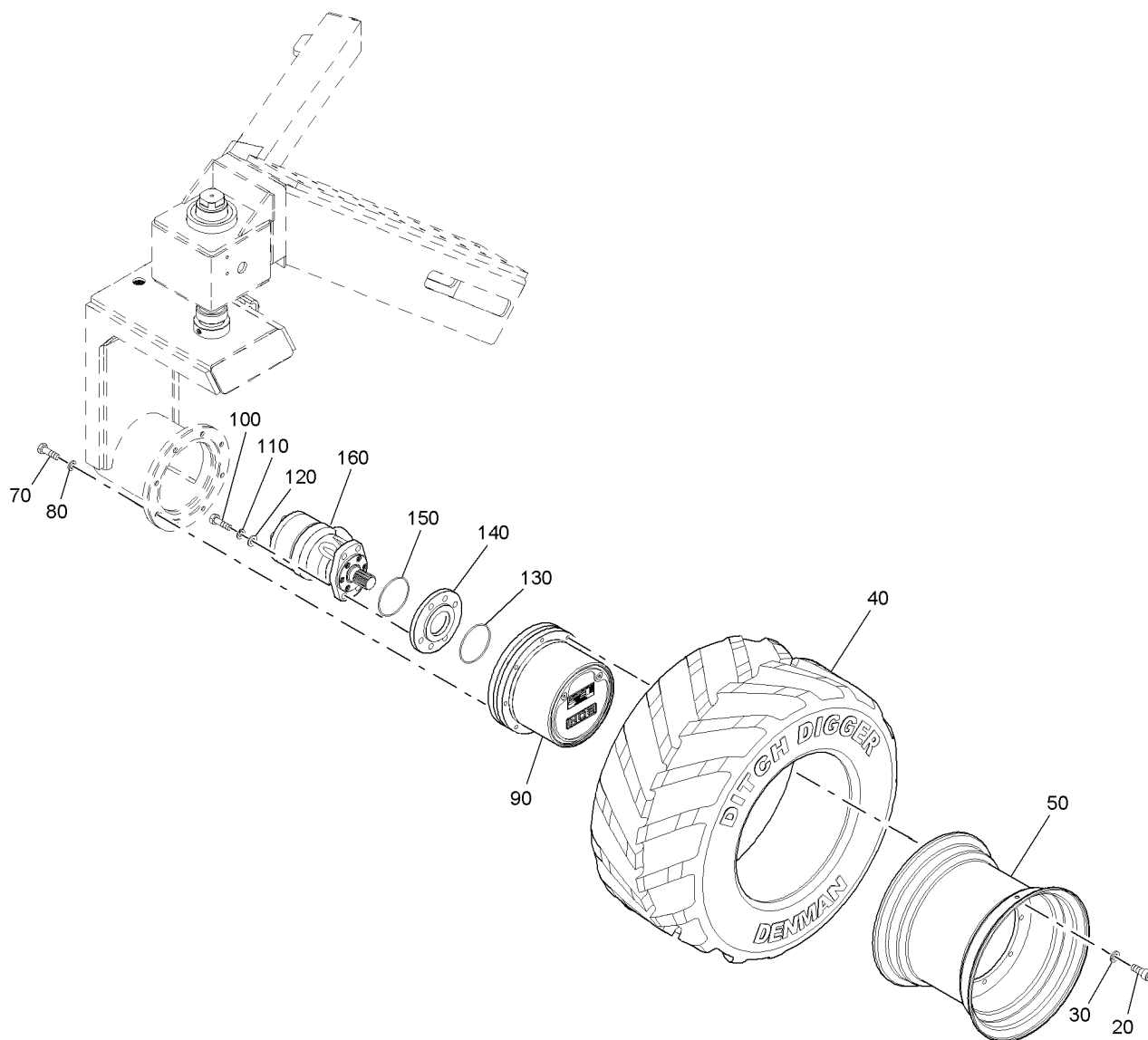

FIGURE 14. FRONT TIRE, WHEEL & TORQUE HUB

TABLE 14. FRONT TIRE, WHEEL & TORQUE HUB

ITEM NO.	PART NO.	DESCRIPTION	QTY.
14			
-1		FRONT TIRE, WHEEL AND TORQUE HUB (See Fig 9 for NHA)	
-10	984131	GROUP, TIRE AND WHEEL LIFT	1
		ATTACHING PARTS	
20	80516	*CSHH, M10-1.50 X 30MM	8
30	118-M10	*WASHER, LOCK, 10MM	8
		-----*-----	
40	984034	*TIRE, DITCH DIGGER (Not Sold Separately)	REF
50	984035	*STANDARD WHEEL (Not Sold Separately)	REF
-60	984733	GROUP, TORQUE HUB/MOTOR	3
		ATTACHING PARTS	
70	80516	*CSHH, M10-1.50 X 30MM	8
80	118-M10	*WASHER, LOCK, 10MM	8
		-----*-----	
90	983873	*TORQUE HUB, 6.09:1, COMER	1
		ATTACHING PARTS	
100	80990	*CSHH, M10-1.50 X 35MM	4
110	118-M10	*WASHER, LOCK, 10MM	4
120	80474	*WASHER, FLAT, M10	4
		-----*-----	
130	984753	*SEAL, O-RING	1
140	984732	*PLATE, SPACER, TORQUE HUB	1
150	984753	*SEAL, O-RING	1
160	985382	*MOTOR, HYD, DRIVE, CURBER	1

- ITEM NOT ILLUSTRATED

TABLE 15. ENGINE & FUEL FILTER (1 OF 3)

ITEM NO.	PART NO.	DESCRIPTION	QTY.
15			
-1	984157	GROUP, ENGINE, KUBOTA & FUEL FILTER (See Fig 9 for NHA)	1
5		ENGINE COOLING SYSTEM (See Figure 16 for Breakdown)	1
-10	987250	*GROUP, EXHAUST, CURBER	1
		ATTACHING PARTS	
20	100-205-1A	*CSHH, .375-24 X 1.00, GR5	2
30	118-3	*WASHER, LOCK .375	2
		-----*	
40	987378	**PIPE, FLEX, MUFFLER	1
		ATTACHING PARTS	
50	71172	**CLAMP, MUFFLER, 2"	2
		-----*	
60	987436	**EXHAUST ELBOW, CURBER	1
		ATTACHING PARTS	
70	71172	**CLAMP, MUFFLER, 2"	1
		-----*	
80	700530	**MUFFLER, 635B W/LOMBARDINI	1
90	36573	**CLAMP, AIR CLEANER MOUNT, 6"ID	1
		ATTACHING PARTS	
100	100-203-1A	**CSHH, .375-24 X .75, GR5	2
110	119-3	**WASHER, FLAT, .375	2
111	143-3	**NUT, LOCK, .375	2
		-----*	
120	987442	**MUFFLER BRACKET, CURBER, W/M	1

- ITEM NOT ILLUSTRATED

TABLE 15. ENGINE & FUEL FILTER (2 OF 3)

ITEM NO.	PART NO.	DESCRIPTION	QTY.
130	986775	*ENGINE, KUBOTA, CURBER, 44HP	1
131	38778-1	**ELEMENT, OIL FILTER, ENGINE KUBOTA	1
132	38385-01	**ELEMENT, AIR FILTER, PRIMARY	1
133	38385-02	**ELEMENT, AIR FILTER, SECONDARY	1
-134	986775-17	**BELL HOUSING, KUBOTA	1
-137	986775-12	**GRP, ELEC THROTTLE, ARM/BASE (Includes items 230 & 400)	1
-138	986775-13	**DIPSTICK, KUBOTA CURBER	1
139	986775-16	**BRACKET, ENGINE MOUNT	4
		ATTACHING PARTS	
140	102-506-1A	*CSHH, .562-12 X 1.250, GR5	4
150	118-6	*WASHER, LOCK, .562	4
151	119-6	*WASHER, FLAT, .562	4
		-----*-----	
160	986775-14	**ENGINE MOUNT	4
		ATTACHING PARTS	
170	102-105-1A	*CSHH, .312-18 X 1.00, GR5	2
180	119-2	*WASHER, FLAT, .312	2
		-----*-----	
190	38845-1	**FILTER ELEMENT, FUEL (Filter Only)	1
200	100-205-1A	*CSHH, .375-24 X 1.00, GR5	2
210	115-3	*NUT, HEX, .375-24	2

- ITEM NOT ILLUSTRATED

Section 5 ILLUSTRATED PARTS LIST

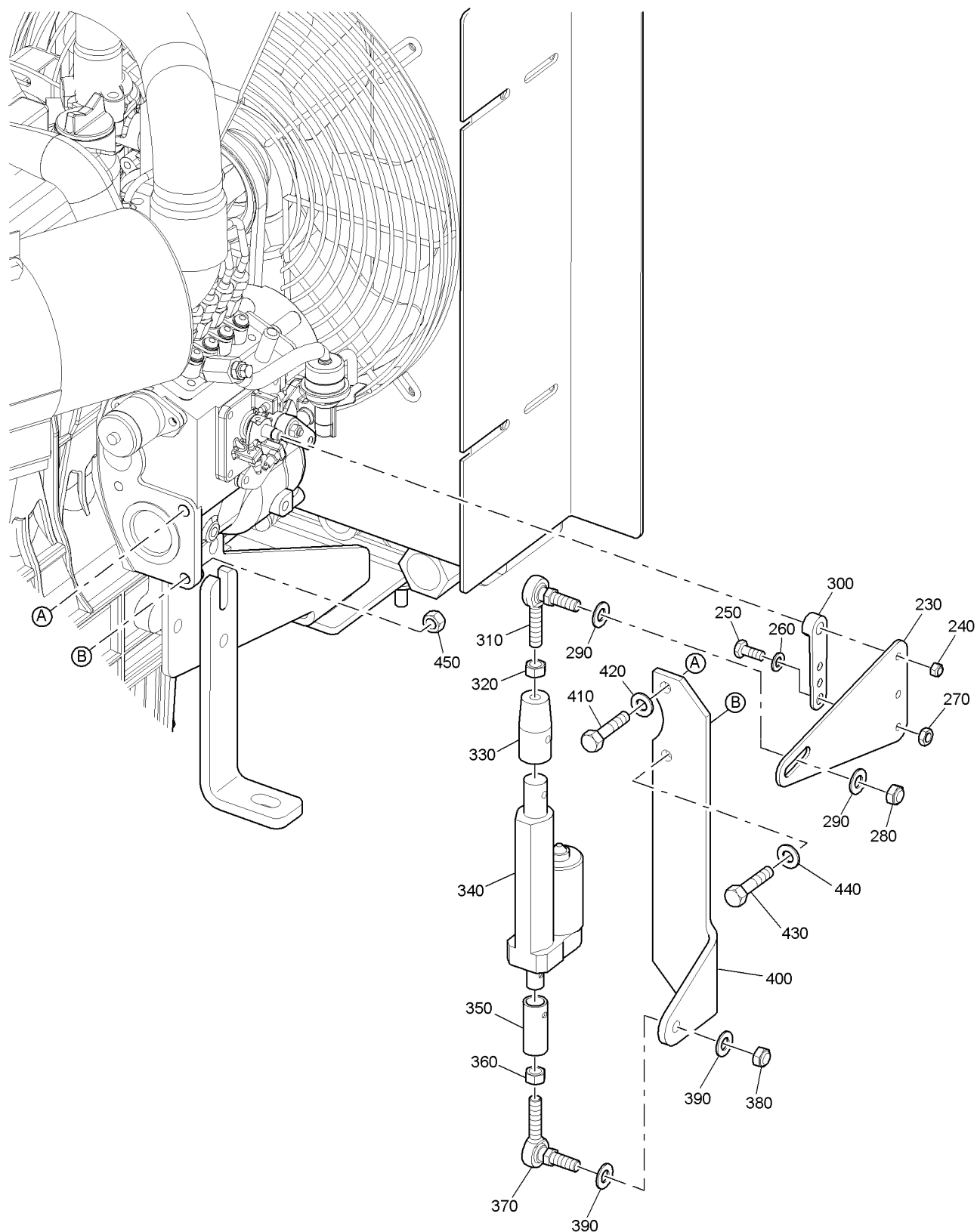

FIGURE 15. ENGINE & FUEL FILTER (2 OF 2)

FIGURE 15. ENGINE & FUEL FILTER (3 OF 3)

ITEM NO.	PART NO.	DESCRIPTION	QTY.
230	986775-11	**ARM, ELECTRIC ACTUATOR	1
		ATTACHING PARTS	
240	80453	*NUT, HEX, M06-1.00	1
250	102-5-1A	*CSHH, .250-20 X 1.00, GR5	2
260	871070928	*WASHER, FLAT, .250-20	2
270	80350	*NUT, LOCK, .250-20	2
280	80370	*NUT, FLEXLOC, .375-24, FULL, LT	1
290	80142	*WASHER, FLAT, USS, .375	2
		-----*-----	
300	986775-18	**THROTTLE LEVER, KUBOTA	1
310	982157	**BALL JOINT, 3/8 - 24 MALE, W/STUD	1
320	80056	**NUT, HEX, .375-24	1
330	980317	**ADAPTER, THROTTLE ACTUATOR, ROD	1
340	23252	**ACTUATOR, EMULSION/THROTTLE	1
350	980318	**ADAPTER, THROTTLE/ACTUATOR, BASE	1
360	80056	**NUT, HEX, .375-24	1
370	982157	**BALL JOINT, 3/8 - 24 MALE, W/STUD	1
380	80370	**NUT, FLEXLOC, .375-24, FULL, LT	1
390	80142	**WASHER, FLAT, USS, .375	2
400	986775-10	**BASE, ELECTRIC ACTUATOR	1
		ATTACHING PARTS	
410	81132	*CSHH, M10-1.25 X 25 MM	1
420	118-M10	*WASHER, LOCK, 10MM	1
430	102-107-1A	*CSHH, .312-18 X 1.50, GR5	1
440	81283	*WASHER, .313 x 1.25, SS	1
450	143-2	*NUT, LOCK, .312-18	1
		-----*-----	

- ITEM NOT ILLUSTRATED

Section 5 ILLUSTRATED PARTS LIST

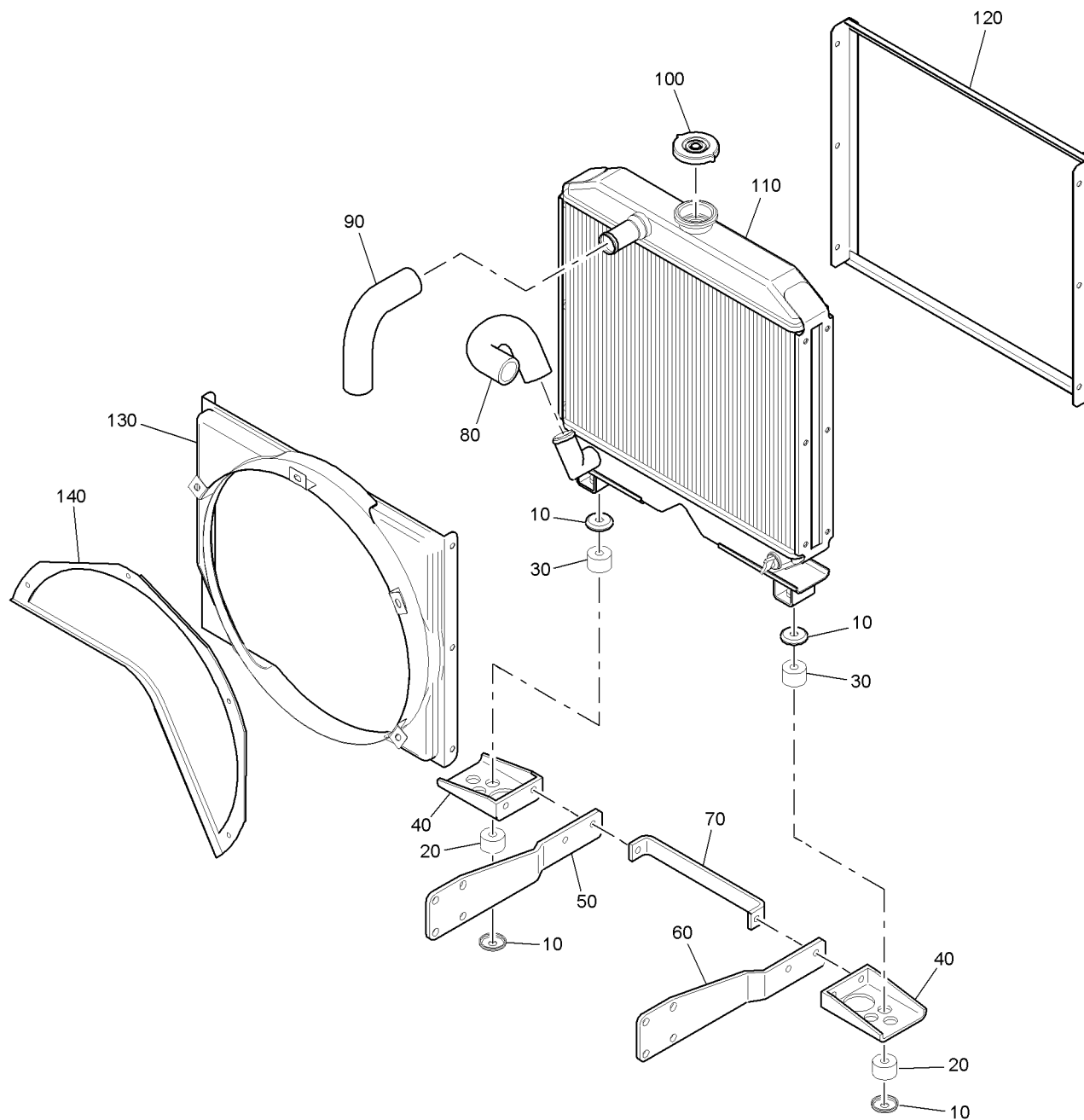

FIGURE 16. ENGINE COOLING SYSTEM

TABLE 16. ENGINE COOLING SYSTEM

ITEM NO.	PART NO.	DESCRIPTION	QTY.
16			
-1		ENGINE COOLING SYSTEM (See Fig 15 for NHA)	
10	984814	*WASHER, VIBRATION ISOLATOR	4
20	984813	*ISOLATOR, VIBRATION, LOWER	2
30	984812	*ISOLATOR, VIBRATION, UPPER	2
40	984811	*MOUNTING BRACKET, ISOLATOR	2
50	984808	*MOUNTING BRACKET, LOWER LEFT	1
60	984809	*MOUNTING BRACKET, LOWER RIGHT	1
70	984810	*MOUNTING BRACKET, CROSS BRACE	1
80	986775-02	*HOSE, RADIATOR, LOWER, KUBOTA	1
90	986775-01	*HOSE, RADIATOR, UPPER, KUBOTA	1
100	986775-03	*PRESSURE CAP, RADIATOR , KUBOTA	1
110	984802	*RADIATOR	1
120	984807	*GUARD, RADIATOR	1
130	984816	*SHROUD, FAN	1
140	984818	*GUARD, FAN	1
-150	986775-15	*BELT, FAN, KUBOTA ENGINE	1

- ITEM NOT ILLUSTRATED

Section 5 ILLUSTRATED PARTS LIST

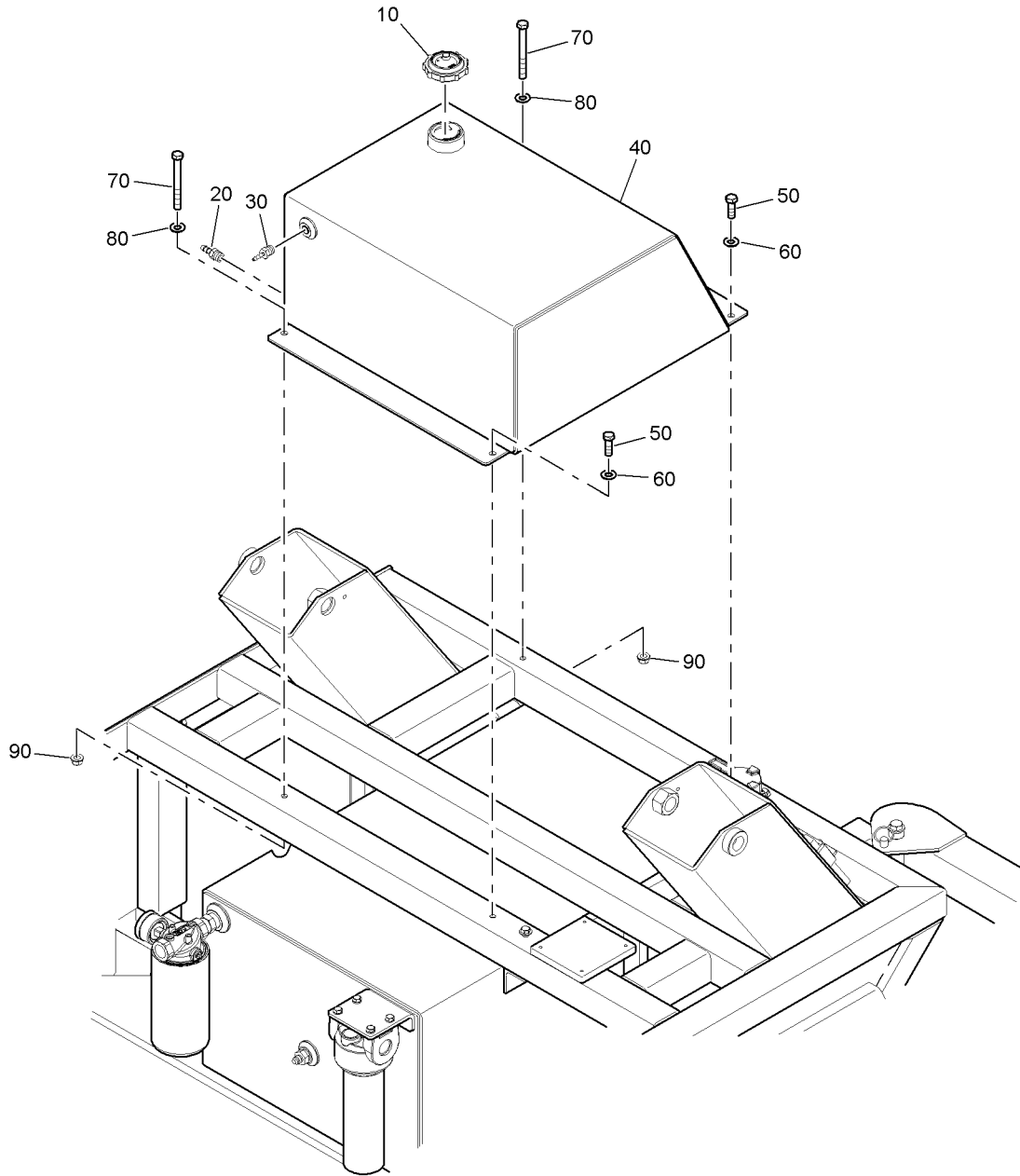

FIGURE 17. FUEL TANK



Section 5 ILLUSTRATED PARTS LIST

TABLE 17. FUEL TANK

ITEM NO.	PART NO.	DESCRIPTION	QTY.
18			
-1	984780	GROUP, FUEL TANK (See Fig 9 for NHA)	1
10	330010	*CAP, FUEL, W/GAUGE	1
20	984117	*BRASS HOSE BARB, 5/16 I.D.	1
30	984118	*BRASS HOSE BARB, 3/16 I.D.	1
40	983817	*FUEL TANK, W/M	1
		ATTACHING PARTS	
50	102-205-1A	*CSHH, .375-16 X 1.00, GR5	2
60	119-3	*WASHER, FLAT, SAE, .375	2
70	102-205-1A	*CSHH, .375-16 X 1.25, GR5	2
80	119-3	*WASHER, FLAT, SAE, .375	2
90	116-3	*NUT, HEX, .375-16	2
		-----*	

- ITEM NOT ILLUSTRATED

Section 5 ILLUSTRATED PARTS LIST

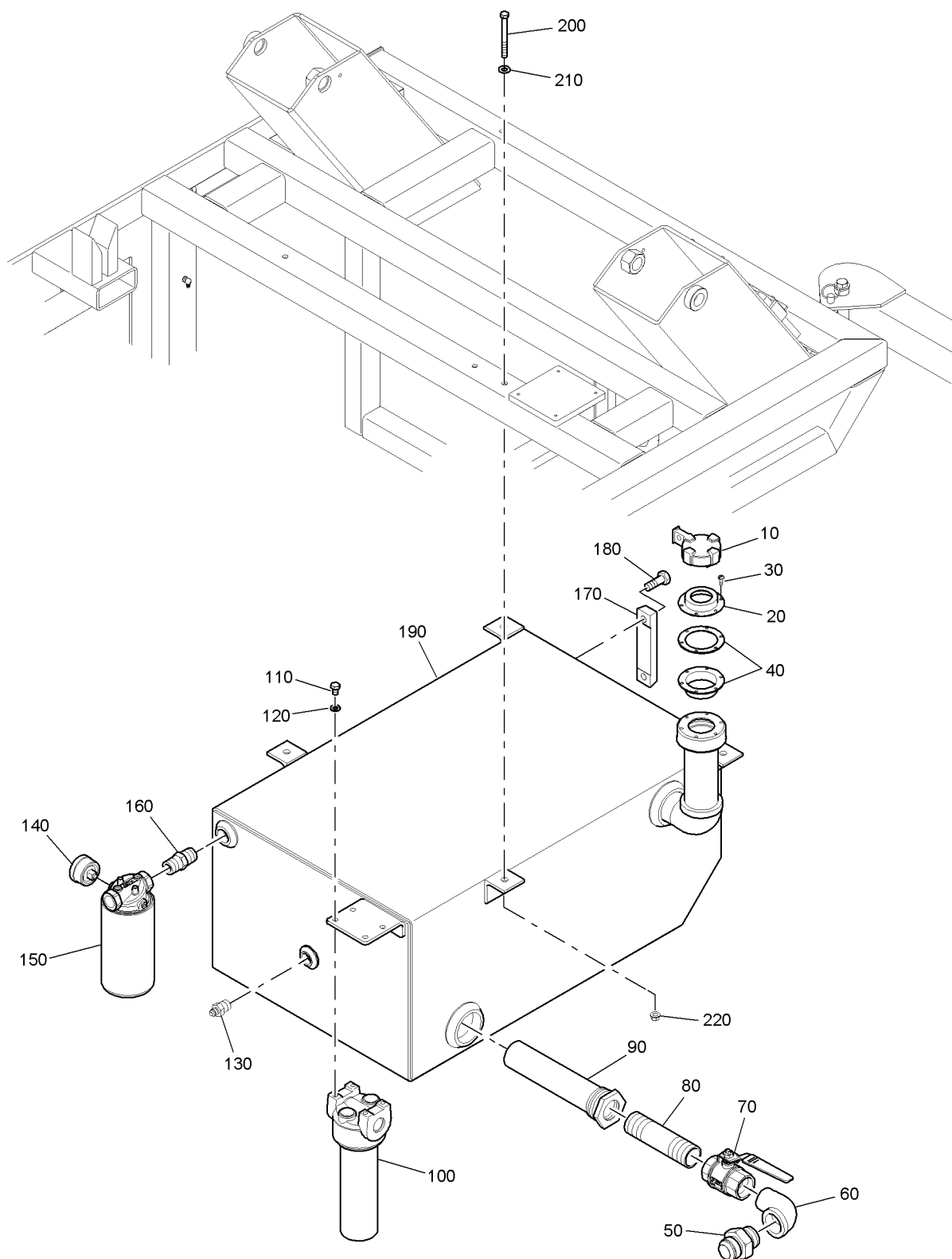

FIGURE 18. HYDRAULIC TANK

TABLE 18. HYDRAULIC TANK

ITEM NO.	PART NO.	DESCRIPTION	QTY.
19			
-1	984778	GROUP, HYD TANK (See Fig 9 for NHA)	1
10	140030HL	*CAP, HYD OIL TANK (LOCKABLE)	1
20	140030FN	*FILLER NECK, HYD OIL/FUEL CAP	1
		ATTACHING PARTS	
30	102-203-1A	*CSHH, .375-16 X .75, GR5	6
		-----*-----	
40	140030GK	*STRAINER & GASKET KIT	1
50	36431	*FITTING, STR, 20MJ-20MP	1
60	99529	*ELBOW PIPE 90 1.250 STRGGT. MI	1
70	38399	*VALVE, BALL, 1.25 NPT BRONZE	1
80	99724	*PIPE, NIPPLE, 1.25 X 6.00	1
90	33148	*STRAINER, SUCTION	1
100	983976	*FILTER, HIGH PRESS	1
-105	984137	**ELEMENT, FILTER, HIGH PRESSURE (Element only)	1
		ATTACHING PARTS	
110	102-105-1A	*CSHH, .312-18 X 1.00, GR5	4
120	118-2	*WASHER, LOCK, .312	4
		-----*-----	
130	34082	*FITTING, STR. 06MJ-08MP	1
140	72543-01	*GAUGE, RETURN LINE FILTER IND	1
150	X259	*FILTER ASSY	1
160	X394	*FITTING, STR. 12MJ-12MP	1
170	500070	*GAUGE, SIGHT LEVEL/TEMP, HYD OIL	1
		ATTACHING PARTS	
180	102-407-1A	*CSHH, .500-13 X 1.50, GR5	2
		-----*-----	
190	983818	*HYDRAULIC TANK	1
		ATTACHING PARTS	
200	102-211-1A	*CSHH, .375-16 X 2.50	2
210	119-3	*WASHER, FLAT, SAE, .375	2
220	116-3	*NUT, HEX, .375-16	2

- ITEM NOT ILLUSTRATED

Section 5 ILLUSTRATED PARTS LIST

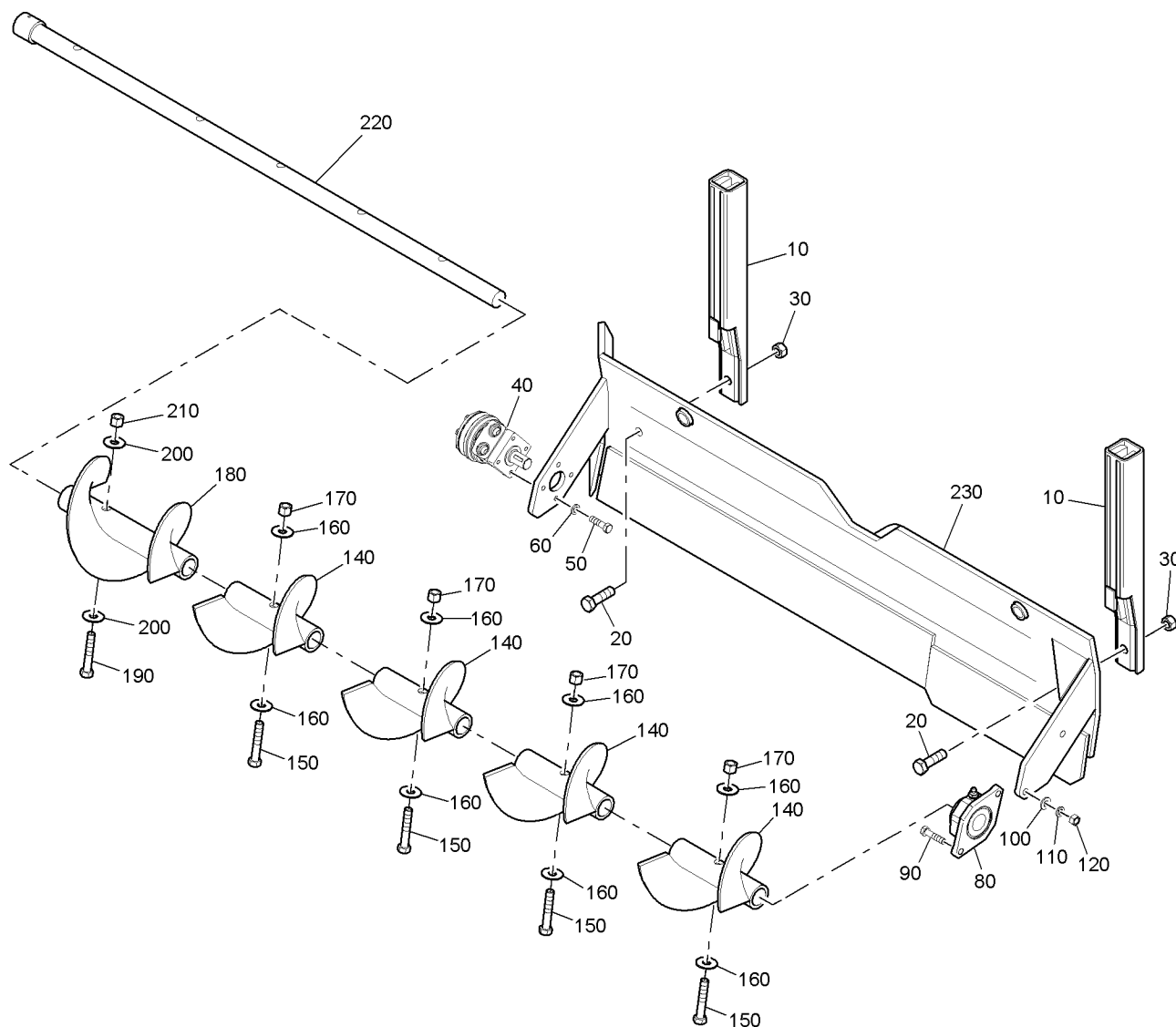

FIGURE 19. AUGER

TABLE 19. AUGER (1 OF 2)

ITEM NO.	PART NO.	DESCRIPTION	QTY.
20			
-1	985319	GROUP, AUGER (See Fig 9 for NHA)	1
10	985318	*LEG AUGER, W/M	2
		ATTACHING PARTS	
20	102-711-1A	*CSHH, .750-10 X 2.50, GR5	1
30	116-8	*NUT, HEX, .750-10	1
		-----*-----	
40	985364	*MOTOR, HYD, AUGERS, CURBER	1
		ATTACHING PARTS	
50	102-408-1A	*CSHH, .500-13 X 1.75, GR5	4
60	118-5	*WASHER, LOCK, .500	4
-70		NOT USED	
		-----*-----	
80	73018	*BEARING, FLANGE, 2-BOLT, 1.50	1
		ATTACHING PARTS	
90	102-409-1A	*CSHH, .500-13 X 2.00, GR5	2
100	119-5	*WASHER, FLAT, SAE, .500	2
110	118-5	*WASHER, LOCK, .500	2
120	116-5	*NUT, HEX, .500-13	2
		-----*-----	
-130	987395	*GROUP, AUGERS & SHAFT, CURBER	1
140	860110C	**AUGER SECTION LH CASTED YELLOW	4
		ATTACHING PARTS	
150	102-615-1A	**CSHH, .625-11 X 3.50, GR5	1
160	119-7	**WASHER, FLAT, SAE, .625	2
170	116-7	**NUT, HEX, .625-11	1
		-----*-----	

- ITEM NOT ILLUSTRATED



Section 5 ILLUSTRATED PARTS LIST

TABLE 19. AUGER (2 OF 2)

ITEM NO.	PART NO.	DESCRIPTION	QTY.
180	987333	**AUGER, 9"ODX14"LG	1
		ATTACHING PARTS	
190	102-615-1A	**CSHH, .625-11 X 3.50, GR5	1
200	119-7	**WASHER, FLAT, SAE, .625	2
210	116-7	**NUT, HEX, .625-11	1
		-----*-----	
220	987357	**CUTTER, AUGER, W/M	1
230	985317	*BLADE, AUGER, W/M	1

- ITEM NOT ILLUSTRATED

Section 5 ILLUSTRATED PARTS LIST

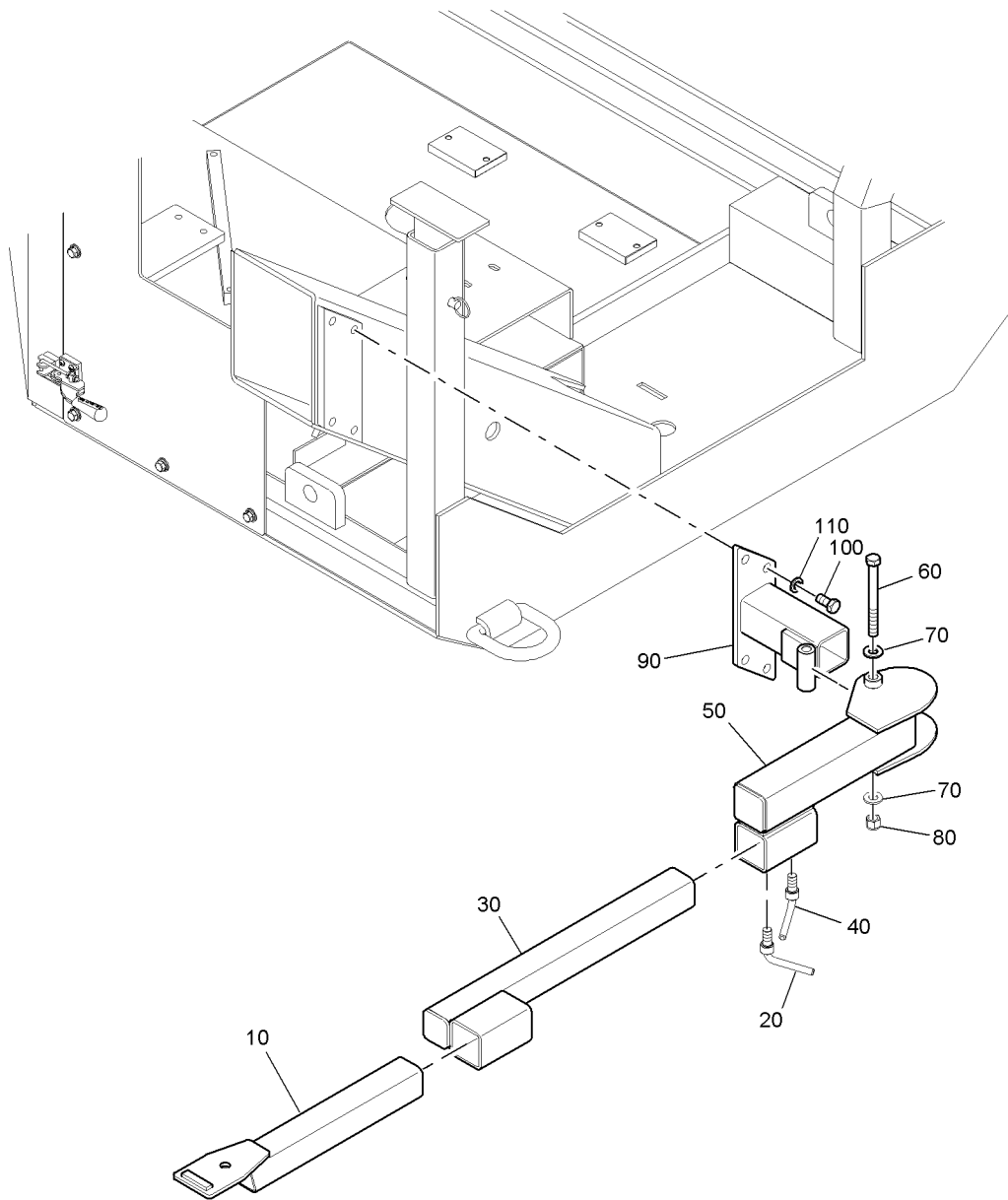

FIGURE 20. SENSOR ARM



Section 5 ILLUSTRATED PARTS LIST

TABLE 20. SENSOR ARM

ITEM NO.	PART NO.	DESCRIPTION	QTY.
21			
-1	985370	GROUP, SENSOR ARM (See Fig 9 for NHA)	1
10	985932	*FRONT, STRINGLINE SENSOR, MOUNTING ARM	1
20	984740	*LOCK, ARM, W/M	1
30	985378	*EXTENSION ARM, W/M	1
40	984740	*LOCK, ARM, W/M	1
50	985375	*PIVOT ARM, W/M	1
		ATTACHING PARTS	
60	102-421-1	*CSHH, .500-13 X 5.00, GR5	1
70	119-5	*WASHER, FLAT, SAE, .500	2
80	143-5	*NUT, LOCK, .500-13	1
		-----*-----	
90	985371	*STATIONARY ARM, W/M	1
		ATTACHING PARTS	
100	102-405-1A	*CSHH, .500-13 X 1.00, GR5	4
110	118-5	*WASHER, LOCK, .500	4
		-----*-----	

- ITEM NOT ILLUSTRATED

Section 5 ILLUSTRATED PARTS LIST

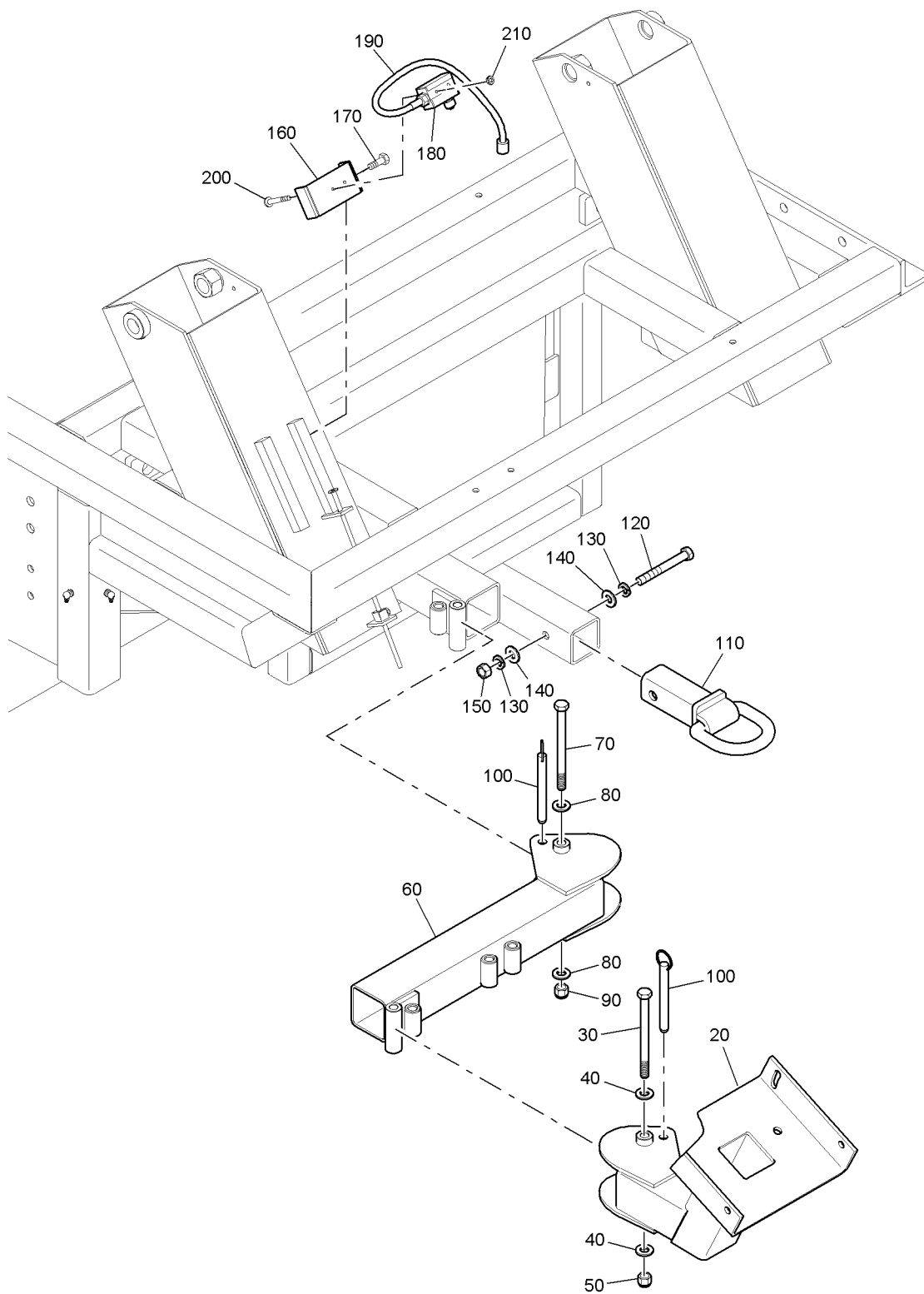

FIGURE 21. CONTROL PEDESTAL & TOW RING

TABLE 21. CONTROL PEDESTAL & TOW RING

ITEM NO.	PART NO.	DESCRIPTION	QTY.
22			
-1		GROUP, CONTROL PEDESTAL & TOW RING	1
-10	987356	GROUP, CONTROL PEDESTAL (See Fig 9 for NHA)	1
20	987309	*ARM, SWITCH PANEL PEDESTAL	1
		ATTACHING PARTS	
30	80467	**CSHH, .500-13 X 6.00, GR5	1
40	119-5	**WASHER, FLAT, SAE, .500	2
50	143-5	**NUT, LOCK, .500-13	1
		-----*	
60	984707	*ARM, INTERMEDIATE	1
		ATTACHING PARTS	
70	80467	**CSHH, .500-13 X 6.00, GR5	1
80	119-5	**WASHER, FLAT, SAE, .500	2
90	143-5	**NUT, LOCK, .500-13	1
		-----*	
100	985384	PIN, QUICK RELEASE	2
110	987364	TOW HOOK, D-RING	1
		ATTACHING PARTS	
120	102-421-1	*CSHH, .500-13 X 5.00, GR5	1
130	118-5	*WASHER, LOCK, .500	2
140	119-5	*WASHER, FLAT, SAE, .500	2
150	116-5	*NUT, HEX, .500-13	1
		-----*	
160	983825	MOUNT, LIMIT SWITCH, W/M (Part of Frame Grp)	1
170	80221	BOLT, 3/8" X 1 HEX (Part of Frame Grp)	1
		-----*	
180	984065	SWITCH, LIMIT (Part of Electrical Grp)	1
190	984837	HARNESS, FT WHEEL, HT (Part of Electrical Grp)	1
200	81079	MACH SCREW, PH, #10-24 X 2.50	2
210	80824	NUT, HEX, #10-24	2
		-----*	

- ITEM NOT ILLUSTRATED

Section 5 ILLUSTRATED PARTS LIST

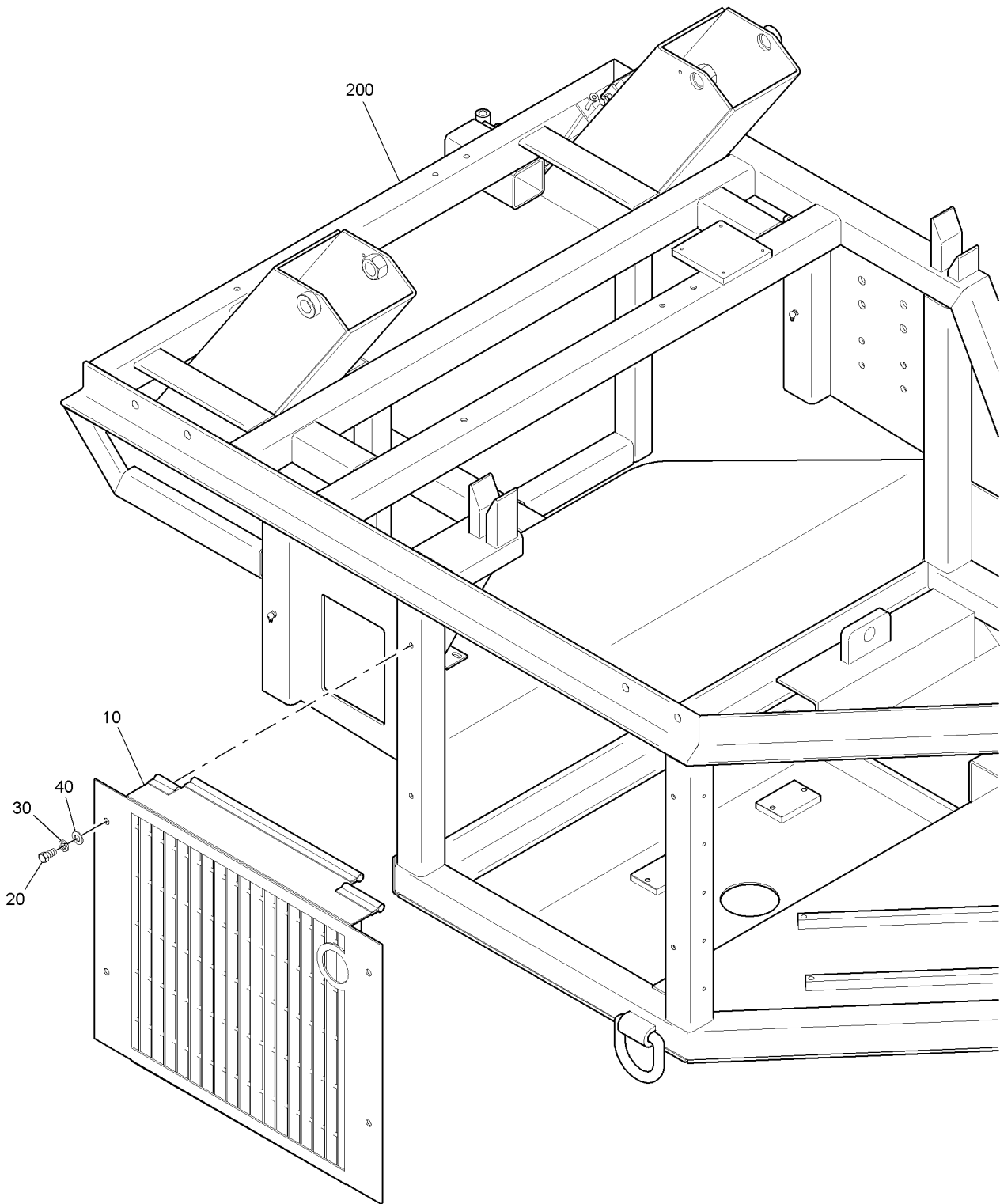

FIGURE 22. ACCESS DOOR & COVER (1 OF 2)



Section 5 ILLUSTRATED PARTS LIST

TABLE 22. ACCESS DOOR & COVER (1 OF 2)

ITEM NO.	PART NO.	DESCRIPTION	QTY.
23			
-1		GROUP, ACCESS DOOR AND COVER (See Fig 9 for NHA)	
10	985900	INST, GRILL LIGHT & HIGH FLOW	1
		ATTACHING PARTS	
20	102-203-1A	*CSHH, .375-16 X .75, GR5	4
30	118-3	*WASHER, LOCK, .375	4
40	119-3	*WASHER, FLAT, SAE, .375	4
		-----*	
-50	984827	*GRILLE	1
200	984184	FRAME, CURBER, W/M	1

- ITEM NOT ILLUSTRATED

Section 5 ILLUSTRATED PARTS LIST

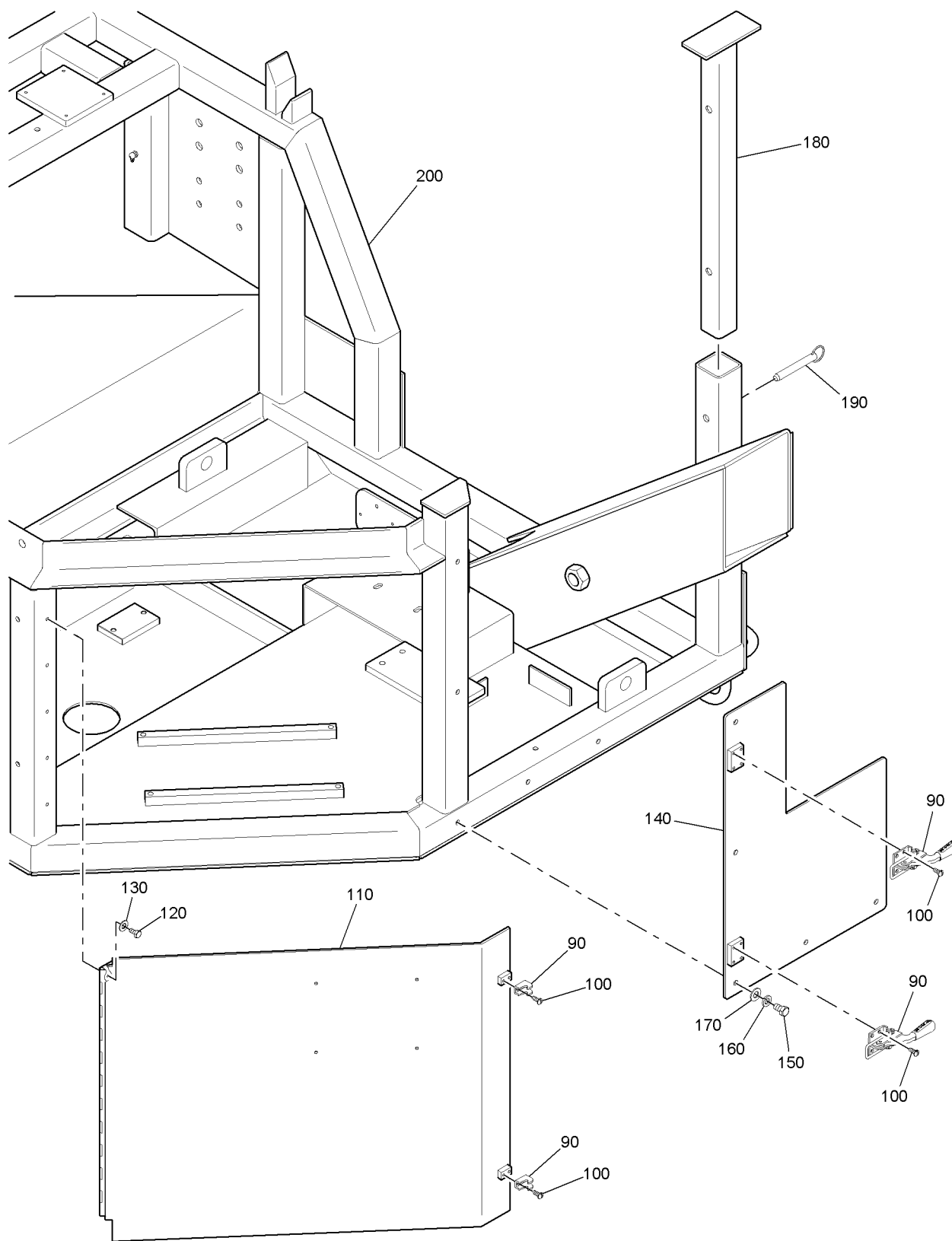

FIGURE 22. ACCESS DOOR & COVER (2 OF 2)



Section 5 ILLUSTRATED PARTS LIST

TABLE 22. ACCESS DOOR & COVER (2 OF 2)

ITEM NO.	PART NO.	DESCRIPTION	QTY.
90	983955	CLAMP, PULL ACTION, ACCESS DOOR	2
		ATTACHING PARTS	
100	102-1-1A	*CSHH, .250-20 X .500	12
		-----*-----	
110	984647	ACCESS DOOR (Part of Frame Grp)	1
		ATTACHING PARTS	
120	102-1-1A	*CSHH, .250-20 X .500	5
130	118-1	*WASHER, LOCK, .250	5
		-----*-----	
140	983830	ACCESS COVER, W/M	1
		ATTACHING PARTS	
150	102-205-1A	*CSHH, .375-16 X 1.00, GR5	5
160	118-3	*WASHER, LOCK, .375	5
170	119-3	*WASHER, FLAT, SAE, .375	5
		-----*-----	
180	985394	SAFETY TUBE	1
190	985384	**PIN, QUICK RELEASE	2
200	984184	FRAME, CURBER, W/M	1

- ITEM NOT ILLUSTRATED

ITEM NO.	PART NO.	DESCRIPTION	IPL PG.
A			
140	983830	ACCESS COVER, W/M	71
110	984647	ACCESS DOOR	71
40	984723	ACCESS PANEL REAR	15
10	984722	ACCESS PANEL, BOTTOM	15
340	23252	ACTUATOR, EMULSION/THROTTLE	53
330	980317	ADAPTER, THROTTLE ACTUATOR, ROD	53
350	980318	ADAPTER, THROTTLE/ACTUATOR, BASE	53
230	986775-11	ARM, ELECTRIC ACTUATOR	53
60	984707	ARM, INTERMEDIATE	67
120	984199-10	ARM, SENSOR, MOLD	9
20	987309	ARM, SWITCH PANEL PEDESTAL	67
220	987370	ARM1, SENSOR COVER, W/M	35
320	985913	ASSEMBLY, FUSEBOX, CURBER	13
95	987415	ATTACH, VERT. ARM, W/M	33
140	860110C	AUGER SECTION LH CASTED YELLOW	61
180	987333	AUGER, 9"ODX14"LG	63
B			
310	982157	BALL JOINT, 3/8 - 24 MALE, W/STUD	53
370	982157	BALL JOINT, 3/8 - 24 MALE, W/STUD	53
400	986775-10	BASE, ELECTRIC ACTUATOR	53
270	314230	BATTERY, 12 VOLT 650 CCA	13
40	210180	BEARING CONE	41
90	210180	BEARING CONE	41
30	210190	BEARING CUP	41
80	210190	BEARING CUP	41
80	73018	BEARING, FLANGE, 2-BOLT, 1.50	61
134	986775-17	BELL HOUSING, KUBOTA	51
150	986775-15	BELT, FAN, KUBOTA ENGINE	55
160	987048	BELT, GEAR, XL, 85 TOOTH	11
230	985317	BLADE, AUGER, W/M	63
170	80221	BOLT, 3/8" X 1 HEX	67
139	986775-16	BRACKET, ENGINE MOUNT	51
230	987251	BRACKET, PULLEY MOTOR	11
30	984118	BRASS HOSE BARB, 3/16 I.D.	57
20	984117	BRASS HOSE BARB, 5/16 I.D.	57
50	983894	BUSHING, TAPER, FRONT WHEEL LIFT	41
C			
10	330010	CAP, FUEL, W/GAUGE	57
10	140030HL	CAP, HYD OIL TANK (LOCKABLE)	59
90	36573	CLAMP, AIR CLEANER MOUNT, 6" ID	49
50	71172	CLAMP, MUFFLER, 2"	49
70	71172	CLAMP, MUFFLER, 2"	49

Section 5

ALPHABETICAL INDEX



ITEM NO.	PART NO.	DESCRIPTION	IPL PG.
90	983955	CLAMP, PULL ACTION, ACCESS DOOR	71
100	984657-06	COIL, 12 VDC DEUTSCH	31
80	984657-07	COIL, 12 VDC W/DEUTSCH CONNECTORS	31
60	984656-14	COIL, CURBER MANIFOLD	29
20	984656-26	COIL, D05 VALVE	29
40	984656-27	COIL, SOLENOID VALVE	29, 31
60	984656-27	COIL, SOLENOID VALVE	31
20	984657-16	COIL, SOLENOID, D03, PROPORTIONAL	31
80	984656-12	COIL, VLV, 12 VDC DIN, CURBER MANIFOLD	29
50	983050	COILED CORD, 6S16S 1.5 TO 7.5 FT.	9, 11
200	987509	CONNECT SENSOR, W/M	35
80	987373	CONNECT, SENSOR COVER	33
320	987308	CONTROL PANEL, CURBER	21
90	984657-04	CONTROL, FLOW, NORM CLOSED PROP	31
30	81238	CSFHS, .250-20 X 1.00	39
70	81238	CSFHS, .250-20 X 1.00	39
100	102-1-1A	CSHH, .250-20 X .500	71
120	102-1-1A	CSHH, .250-20 X .500	71
20	102-05-1A	CSHH, .250-20 X 1.00	15
50	102-05-1A	CSHH, .250-20 X 1.00	15
250	102-5-1A	CSHH, .250-20 X 1.00, GR5	53
140	102-7-1A	CSHH, .250-20 X 1.50, GR5	41
200	102-7-1A	CSHH, .250-20 X 1.50, GR5	11
290	102-11-1A	CSHH, .250-20 X 2.50, GR5	13
20	102-105-1A	CSHH, .312-18 X 1.00, GR5	35
110	102-105-1A	CSHH, .312-18 X 1.00, GR5	59
170	102-105-1A	CSHH, .312-18 X 1.00, GR5	51
240	80206	CSHH, .312-18 X 1.25, GR5	11
430	102-107-1A	CSHH, .312-18 X 1.50, GR5	53
80	102-202-1A	CSHH, .375-16 X .50, GR5	17
20	102-203-1A	CSHH, .375-16 X .75, GR5	69
30	102-203-1A	CSHH, .375-16 X .75, GR5	59
100	102-203-1A	CSHH, .375-16 X .75, GR5	35
140	102-203-1A	CSHH, .375-16 X .75, GR5	35
20	102-205-1A	CSHH, .375-16 X 1.00, GR5	7
50	102-205-1A	CSHH, .375-16 X 1.00, GR5	57
150	102-205-1A	CSHH, .375-16 X 1.00, GR5	71
230	102-205-1A	CSHH, .375-16 X 1.00, GR5	27
260	102-205-1A	CSHH, .375-16 X 1.00, GR5	27
290	102-205-1A	CSHH, .375-16 X 1.00, GR5	27
70	102-206-1A	CSHH, .375-16 X 1.25, GR5	57
200	102-211-1A	CSHH, .375-16 X 2.50, GR5	59
100	100-203-1A	CSHH, .375-24 X .75, GR5	49



Section 5 ALPHABETICAL INDEX

ITEM NO.	PART NO.	DESCRIPTION	IPL PG.
20	100-205-1A	CSHH, .375-24 X 1.00, GR5	49
200	100-205-1A	CSHH, .375-24 X 1.00, GR5	51
60	102-405-1A	CSHH, .500-13 X 1.00, GR5	35
100	102-405-1A	CSHH, .500-13 X 1.00, GR5	65
190	102-406-1A	CSHH, .500-13 X 1.25, GR5	27
180	102-407-1A	CSHH, .500-13 X 1.50, GR5	59
50	102-408-1A	CSHH, .500-13 X 1.75, GR5	61
90	102-409-1A	CSHH, .500-13 X 2.00, GR5	61
60	102-421-1	CSHH, .500-13 X 5.00, GR5	65
120	102-421-1	CSHH, .500-13 X 5.00, GR5	67
30	80467	CSHH, .500-13 X 6.00, GR5	67
70	80467	CSHH, .500-13 X 6.00, GR5	67
140	102-506-1A	CSHH, .562-12 X 1.25, GR5	51
20	102-607-1A	CSHH, .625-11 X 1.50, GR5	33
150	102-615-1A	CSHH, .625-11 X 3.50, GR5	61
190	102-615-1A	CSHH, .625-11 X 3.50, GR5	63
20	102-711-1A	CSHH, .750-10 X 2.50, GR5	61
70	100-913-1A	CSHH, 1.00-14 X 3.00, GR5	23
130	102-921-1A	CSHH, 1.00-8 X 5.00, GR5	23
160	102-921-1A	CSHH, 1.00-8 X 5.00, GR5	23
120	81184	CSHH, 1.00-8 X 8.00, GR5	23
150	81184	CSHH, 1.00-8 X 8.00, GR5	23
410	81132	CSHH, M10-1.25 X 25 MM	53
20	80516	CSHH, M10-1.50 X 30MM	43, 45, 47
70	80516	CSHH, M10-1.50 X 30MM	43, 45, 47
100	80990	CSHH, M10-1.50 X 35MM	43, 45, 47
11	984657-11	CSSH, 10-24 X 1.75	31
31	984656-18	CSSH, 10-24 X 1.75	29
31	984657-11	CSSH, 10-24 X 1.75	31
51	984657-11	CSSH, 10-24 X 1.75	31
11	984656-22	CSSH, 25-20 X 1.50	29
220	987357	CUTTER, AUGER, W/M	63
110	983980	CYLINDER, HYDRAULIC, 2.50 X 10.00 X 1.125 ROD	23
80	870091	CYLINDER, HYDRAULIC, 2.50 X 12.00 X 1.125 ROD	25
40	983981	CYLINDER, HYDRAULIC, 2.50 X 16.00 X 1.125 ROD	23
10	983979	CYLINDER, HYDRAULIC, 2.50 X 4.00 X 1.125 ROD	23
140	985351	CYLINDER, HYDRAULIC, 2.50 X 8.00 X 1.125 ROD	23
D			
10	984656-11	D05 PROPORTIONAL DCV	29
300	985385	DECAL, CURBER PANEL, BOTTOM	21
310	985386	DECAL, CURBER PANEL, TOP	21
221	984656-23	DECAL, CURBER, HYD DRIVE	27
251	984657-14	DECAL, VLV, CURBER ACCESSORY	27
138	986775-13	DIPSTICK, KUBOTA CURBER	51

Section 5

ALPHABETICAL INDEX



ITEM NO.	PART NO.	DESCRIPTION	IPL PG.
E			
60	99529	ELBOW PIPE 90 1.250 STRGGT. MI	59
132	38385-01	ELEMENT, AIR FILTER, PRIMARY	51
133	38385-02	ELEMENT, AIR FILTER, SECONDARY	51
105	984137	ELEMENT, FILTER, HIGH PRESSURE	59
120	984656-09	ELEMENT, LOGIC, N.O.	29
131	38778-1	ELEMENT, OIL FILTER, ENGINE KUBOTA	51
1		ENGINE COOLING SYSTEM	55
5		ENGINE COOLING SYSTEM	49
160	986775-14	ENGINE MOUNT	51
130	986775	ENGINE, KUBOTA, CURBER, 44HP	51
60	987436	EXHAUST ELBOW, CURBER	49
30	985378	EXTENSION ARM, W/M	65
F			
20	140030FN	FILLER NECK, HYD OIL/FUEL CAP	59
150	X259	FILTER ASSY	59
190	38845-1	FILTER ELEMENT, FUEL	51
100	983976	FILTER, HIGH PRESS	59
130	34082	FITTING, STR. 06MJ-08MP	59
160	X394	FITTING, STR. 12MJ-12MP	59
50	36431	FITTING, STR, 20MJ-20MP	59
130	984656-03	FLOW DIVIDER/COMBINER	29
60	983914	FOOT, WHEEL LIFT, FRONT, W/M	41
200	984184	FRAME, CURBER, W/M	69, 71
1		FRONT TIRE, & WHEEL AND TORQUE HUB	47
10	985932	FRONT, STRINGLINE SENSOR, MOUNTING ARM	65
180	985932	FRONT, STRINGLINE SENSOR, MOUNTING ARM	35
40	983817	FUEL TANK, W/M	57
350	984674	FUSE, 40 AMP, (MAXI)	13
360	985747	FUSE, 5 AMP, ATM(MINI)	13
370	984676	FUSE, 7.5 AMP, ATM(MINI)	13
340	984673	FUSE, 70 AMP, (MAXI)	13
G			
140	72543-01	GAUGE, RETURN LINE FILTER IND	59
170	500070	GAUGE, SIGHT LEVEL/TEMP, HYD OIL	59
50	984827	GRILLE	69
50	987409	GROUP, ATTACH ARM	33
1		GROUP, ACCESS DOOR AND COVER	69
130		GROUP, ACCESS DOOR AND COVER	37
1	985319	GROUP, AUGER	61
100	985319	GROUP, AUGER	37
130	987395	GROUP, AUGERS & SHAFT, CURBER	61
10	987335	GROUP, CONTROL CONSOLE	7



Section 5 ALPHABETICAL INDEX

ITEM NO.	PART NO.	DESCRIPTION	IPL PG.
1	987335	GROUP, CONTROL CONSOLE, CURBER	15
10	987356	GROUP, CONTROL PEDESTAL	67
1		GROUP, CONTROL PEDESTAL & TOW RING	67
120		GROUP, CONTROL PEDESTAL & TOW RING	37
40	987344	GROUP, COVER	5
1	987344	GROUP, COVER, CURBER	35
10	987198	GROUP, ELECTRICAL	5
1	987198	GROUP, ELECTRICAL, CURBER	7
70	984157	GROUP, ENGINE, KUBOTA	37
1	984157	GROUP, ENGINE, KUBOTA & FUEL FILTER	49
1	984157	GROUP, ENGINE, KUBOTA & FUEL FILTER	49
10	987250	GROUP, EXHAUST, CURBER	49
60	984190	GROUP, FRAME	5
1	984190	GROUP, FRAME, CURBER	37
60		GROUP, FRONT TIRE, WHEEL AND TORQUE HUB	37
150	985928	GROUP, FRONT WHEEL SENSOR	11
1	984780	GROUP, FUEL TANK	57
80	984780	GROUP, FUEL TANK	37
1	984778	GROUP, HYD TANK	59
1	987197	GROUP, HYDRAULIC	23
20	987197	GROUP, HYDRAULIC	5
90	984778	GROUP, HYDRAULIC TANK	37
40		GROUP, LEFT REAR TIRE, WHEEL AND TORQUE HUB	37
30	986878-06	GROUP, MOLD	5
1	986878-06	GROUP, MOLD, CURBER	33
10	987275	GROUP, NOSE COVER	35
50		GROUP, RIGHT REAR TIRE, WHEEL AND TORQUE HUB	37
1	985370	GROUP, SENSOR ARM	65
110	985370	GROUP, SENSOR ARM	37
170	987369	GROUP, SENSOR ARM COVER	35
10	984131	GROUP, TIRE AND WHEEL LEFT	43, 47
10	984033	GROUP, TIRE AND WHEEL RIGHT	45
60	984733	GROUP, TORQUE HUB/MOTOR	43, 45, 47
1	983821	GROUP, WHEEL LIFT, FRONT	41
30	983821	GROUP, WHEEL LIFT, FRONT	37
20	983820	GROUP, WHEEL LIFT, LEFT REAR	37
50	983820	GROUP, WHEEL LIFT, LEFT REAR	39
10	983819	GROUP, WHEEL LIFT, RIGHT REAR	37, 39
460	986775-12	GRP, ELEC THROTTLE, ARM/BASE	53
137	986775-12	GRP, ELECTRICAL THROTTLE, ARM/BASE	51
140	984818	GUARD, FAN	55
120	984807	GUARD, RADIATOR	55

Section 5

ALPHABETICAL INDEX



ITEM NO.	PART NO.	DESCRIPTION	IPL PG.
H			
13	983414-08	HARNESS, COIL, TOPCON	17
410	984663	HARNESS, ENGINE, CURBER	13
400	984662	HARNESS, FRAME, CURBER	13
190	984837	HARNESS, FT WHEEL, HT	67
430	984685	HARNESS, FUSE BLOCK, CURBER	13
420	984664	HARNESS, PEDESTAL, CURBER	13
11	984199-03	HARNESS, SLOPE SENSOR, TOPCON	17
110	984199-03	HARNESS, SLOPE SENSOR, TOPCON	5
12	984199-04	HARNESS, VALVE BLOCK, TOPCON	17
50	984080	HINGE, MALE	5
60	987429	HORIZONTAL, ATTACH, ARM	33
80	986775-02	HOSE, RADIATOR, LOWER, KUBOTA	55
90	986775-01	HOSE, RADIATOR, UPPER, KUBOTA	55
120	300109	HOUSING, YOKE SHAFT	41
190	983818	HYDRAULIC TANK	59
I			
10	985900	INST, GRILL LIGHT & HIGH FLOW	69
20	984813	ISOLATOR, VIBRATION, LOWER	55
30	984812	ISOLATOR, VIBRATION, UPPER	55
J			
90	984199-08	J-BOX, TOPCON	5
K			
330	984145-01	KEY, FOR SWITCH, IGNITION	21
110	129-413	KEYSTOCK, SQ, 0.500 X 2.00	41
70	984199	KIT, CON-TEC, BASE CONTROL, TOPCON	17
80	984600	KIT, DECAL, LOGO	5
70	983607	KIT, DECAL, SAFETY/OPS	5
320	987199	KIT, FITT/HOSE, CURBER	27
100	984200	KIT, RS485 WAND SENSOR, TOPCON	9
220	72055	KNOB, 0.25 SHAFT, POTENTIOMETER	19
280	981510	KNOB, EMERGENCY SWITCH	21
L			
1	983700	LBC24W44 CURBER	5
1		LEFT AND RIGHT WHEEL LIFT GROUP	39
1		LEFT REAR TIRE, WHEEL AND TORQUE HUB	43
10	985318	LEG AUGER, W/M	61
100	31986	LIGHT, BLUE, DASH	17
110	31985	LIGHT, GREEN, DASH	17, 19
20	984740	LOCK, ARM, W/M	65
40	984740	LOCK, ARM, W/M	65
70	984740	LOCK, ARM, W/M	33
90	984740	LOCK, ARM, W/M	33



Section 5 ALPHABETICAL INDEX

ITEM NO.	PART NO.	DESCRIPTION	IPL PG.
190	984740	LOCK, ARM, W/M	35
210	984740	LOCK, ARM, W/M	35
M			
200	81079	MACH SCREW, PH, #10-24 X 2.50	67
280	985925	MICRO PROCESSOR, PLUS 1, CURBER	13
40	985364	MOTOR, HYD, AUGERS, CURBER	61
160	985382	MOTOR, HYD, DRIVE, CURBER	43, 45, 47
160	983825	MOUNT, LIMIT SWITCH, W/M	67
90	985266	MOUNT, VIBRATOR, ANGLE	35
70	984810	MOUNTING BRACKET, CROSS BRACE	55
40	984811	MOUNTING BRACKET, ISOLATOR	55
50	984808	MOUNTING BRACKET, LOWER LEFT	55
60	984809	MOUNTING BRACKET, LOWER RIGHT	55
130	984076	MOUNTING BRACKET, W/M	35
120	987442	MUFFLER BRACKET, CURBER, W/M	49
80	700530	MUFFLER, 635B W/LOMBARDINI	49
N			
280	80370	NUT, FLEXLOC, .375-24, FULL, LT	53
380	80370	NUT, FLEXLOC, .375-24, FULL, LT	53
210	80824	NUT, HEX, #10-24	67
220	116-1	NUT, HEX, .250-20	11
40	116-2	NUT, HEX, .312-18	35
40	116-3	NUT, HEX, .375-16	7
90	116-3	NUT, HEX, .375-16	57
120	116-3	NUT, HEX, .375-16	35
160	116-3	NUT, HEX, .375-16	35
220	116-3	NUT, HEX, .375-16	59
110	115-3	NUT, HEX, .375-24	33
210	115-3	NUT, HEX, .375-24	51
320	80056	NUT, HEX, .375-24	53
360	80056	NUT, HEX, .375-24	53
80	116-5	NUT, HEX, .500-13	35
90	116-5	NUT, HEX, .500-13	9
120	116-5	NUT, HEX, .500-13	61
140	116-5	NUT, HEX, .500-13	9
150	116-5	NUT, HEX, .500-13	67
40	116-7	NUT, HEX, .625-11	33
170	116-7	NUT, HEX, .625-11	61
210	116-7	NUT, HEX, .625-11	63
30	116-8	NUT, HEX, .750-10	61
55	984656-28	NUT, HEX, COIL ZL70	29
240	80453	NUT, HEX, M06-1.00	53
75	984657-15	NUT, HEX, SOLENOID COIL	29, 31

Section 5

ALPHABETICAL INDEX



ITEM NO.	PART NO.	DESCRIPTION	IPL PG.
95	984657-15	NUT, HEX, SOLENOID COIL	31
15	984656-25	NUT, KNULE, D03 VALVE	31
35	984656-25	NUT, KNULE, D03 VALVE	29, 31
55	984656-25	NUT, KNULE, D03 VALVE	31
15	984656-24	NUT, KNULE, D05 VALVE	29
270	80350	NUT, LOCK, .250-20	53
111	143-2	NUT, LOCK, .312-18	49
181	143-2	NUT, LOCK, .312-18	11
450	143-2	NUT, LOCK, .312-18	53
50	143-5	NUT, LOCK, .500-13	67
80	143-5	NUT, LOCK, .500-13	65
90	143-5	NUT, LOCK, .500-13	67
140	987906	NUT, TOGGLE SWITCH	17, 19
170	987906	NUT, TOGGLE SWITCH	17, 19
190	987906	NUT, TOGGLE SWITCH	19
210	987906	NUT, TOGGLE SWITCH	19
240	987906	NUT, TOGGLE SWITCH	19
260	987906	NUT, TOGGLE SWITCH	19
O			
180	984656-20	ORIFICE, REMOVABLE	29
P			
50	985259	PANEL, EXTENSION, HOPPER	35
20	210060	PIN, CLEVIS, 1.00 X 2.625 W/1.5 HD	23
50	210060	PIN, CLEVIS, 1.00 X 2.625 W/1.5 HD	23
90	210060	PIN, CLEVIS, 1.00 X 2.625 W/1.5 HD	25
30	80336	PIN, COTTER, .188 X 1.50	23
60	80336	PIN, COTTER, .188 X 1.50	23
100	80336	PIN, COTTER, .188 X 1.50	25
100	985384	PIN, QUICK RELEASE	67
190	985384	PIN, QUICK RELEASE	71
40	987378	PIPE, FLEX, MUFFLER	49
80	99724	PIPE, NIPPLE, 1.25 X 6.00	59
95	984656-08	PISTON, SINGLE PILOT	29
50	985375	PIVOT ARM, W/M	65
280	987330	PLATE, REAR MANIFOLD	27
140	984732	PLATE, SPACER, TORQUE HUB	43, 45, 47
190	984656-21	PLUG, 5MM EXPANSION	29
170	984656-19	PLUG, MB700-070	29
140	984656-15	PLUG, SAE02	29
150	984657-13	PLUG, SAE02	31
26	984656-17	PLUG, SAE04	29
160	984656-17	PLUG, SAE04	29
140	984657-12	PLUG, SAE06	31



Section 5 ALPHABETICAL INDEX

ITEM NO.	PART NO.	DESCRIPTION	IPL PG.
150	984656-16	PLUG, SAE06	29
230	72857	POTENTIOMETER, 50 OHM, 25 WATT	19
100	986775-03	PRESSURE CAP, RADIATOR , KUBOTA	55
170	985916	PULLEY, GEARBELT, STEERING	11
180	984655	PUMP, HYDRAULIC	27
R			
110	984802	RADIATOR	55
390	986044	RELAY MOUNT, STARTER, W/M	13
380	36085	RELAY, 12VDC, CUBE, UNSEALED	13
330	984155	RELAY, 75 AMP, 12VDC	13
1		RIGHT REAR TIRE, WHEEL AND TORQUE HUB	45
S			
180	985394	SAFETY TUBE	71
20	210240	SEAL	41
70	210240	SEAL	41
130	984753	SEAL, O-RING	43, 45, 47
150	984753	SEAL, O-RING	43, 45, 47
60	985921	SENSOR, ROTATING, STRING LINE	9
110	984199-09	SENSOR, ROTATING, STRING LINE	9
190	985915	SENSOR, ROTATION	11
100	984199-06	SENSOR, SLOPE, TOPCON	5
70	985922	SENSOR, WAND	9
11	80392	SET SCREW, .250-20 X .500	41
130	984816	SHROUD, FAN	55
140	987413	SLIDE, MOLD BACK	33
100	987412	SLIDE, MOLD FRONT	33
10	987130	SPINDLE NUT, MODIFIED	41
10	987406	STANDARD MOLD	33
50	984035	STANDARD WHEEL	43, 45, 47
90	985371	STATIONARY ARM, W/M	65
100	987131	STEERING PIN, FRONT WHEEL LIFT	41
40	140030GK	STRAINER & GASKET KIT	59
90	33148	STRAINER, SUCTION	59
270	981507	SWITCH, EMERGENCY STOP	21
290	984145	SWITCH, IGNITION	21
180	984065	SWITCH, LIMIT	67
150	851392	SWITCH, TOGGLE, 3-POS, SPDT	17, 19
180	72086	SWITCH, TOGGLE, DPDT	19
250	851390	SWITCH, TOGGLE, DPDT	19
200	37521	SWITCH, TOGGLE, DPDT, 3-POS	19
120	851391	SWITCH, TOGGLE, SPST	17, 19

Section 5

ALPHABETICAL INDEX



ITEM NO.	PART NO.	DESCRIPTION	IPL PG.
T			
180	22025	THD'D ROD, .312-18 X 2.50,GR5	11
300	986775-18	THROTTLE LEVER, KUBOTA	53
40	984034	TIRE, DITCH DIGGER	43, 45, 47
230	983703	TOP, COVER/CHUTE, W/M	35
90	983873	TORQUE HUB, 6.09:1, COMER	43, 45, 47
110	987364	TOW HOOK, D-RING	67
V			
130	984657-01	VALVE BODY	31
135	984656-01	VALVE BODY	29
70	38399	VALVE, BALL, 1.25 NPT BRONZE	59
1	984656	VALVE, HYD, DRIVE MANIFOLD	29
1	984657	VALVE, HYD, MANIFOLD, REAR	31
220	984656	VALVE, HYDRAULIC, DRIVE MANIFOLD	27
250	984657	VALVE, HYDRAULIC, MANIFOLD, REAR	27
170	984081	VIBRATOR, HYD, CURVED	27
15	984081	VIBRATOR, HYD, CURVED 10,500 VPM	35
310	987088	VIBRATOR, HYD, STR	27
16	987088	VIBRATOR, HYD, STR, 10,500 VPM	35
50	984656-13	VLV, BI-DIR. PROP FLOW CONTROL	29
90	984656-07	VLV, CHECK	29
110	984656-02	VLV, COUNTERBALANCE	29
110	984657-02	VLV, COUNTERBALANCE	31
10	984657-08	VLV, D03 PROPORTIONAL	31
30	984656-06	VLV, D03 SOLENOID	29
30	984657-10	VLV, D03 SOLENOID	31
50	984657-10	VLV, D03 SOLENOID	31
100	984656-05	VLV, NEEDLE	29
120	984657-03	VLV, NEEDLE	31
25	984656-10	VLV, SHUTTLE	29
70	984656-04	VLV, SOLENOID	29
70	984657-05	VLV, SOLENOID	31
W			
440	81283	WASHER, .313 x 1.25, SS	53
260	871070928	WASHER, FLAT, .250-20	53
120	80474	WASHER, FLAT, M10	43, 45, 47
310	119-1	WASHER, FLAT, SAE, .250	13
182	119-2	WASHER, FLAT, SAE, .312	11
260	119-2	WASHER, FLAT, SAE, .312	11
180	119-2	WASHER, FLAT, SAE, .312	51
40	119-3	WASHER, FLAT, SAE, .375	69
60	119-3	WASHER, FLAT, SAE, .375	57
80	119-3	WASHER, FLAT, SAE, .375	57



Section 5 ALPHABETICAL INDEX

ITEM NO.	PART NO.	DESCRIPTION	IPL PG.
90	119-3	WASHER, FLAT, SAE, .375	17
110	119-3	WASHER, FLAT, SAE, .375	49
130	119-3	WASHER, FLAT, SAE, .375	33
170	119-3	WASHER, FLAT, SAE, .375	71
210	119-3	WASHER, FLAT, SAE, .375	59
270	119-3	WASHER, FLAT, SAE, .375	27
40	119-5	WASHER, FLAT, SAE, .500	67
70	119-5	WASHER, FLAT, SAE, .500	65
80	119-5	WASHER, FLAT, SAE, .500	67
100	119-5	WASHER, FLAT, SAE, .500	61
130	119-5	WASHER, FLAT, SAE, .500	17, 19
140	119-5	WASHER, FLAT, SAE, .500	67
160	119-5	WASHER, FLAT, SAE, .500	17, 19
210	119-5	WASHER, FLAT, SAE, .500	27
150	119-6	WASHER, FLAT, SAE, .562	51
160	119-7	WASHER, FLAT, SAE, .625	61
200	119-7	WASHER, FLAT, SAE, .625	63
290	80142	WASHER, FLAT, USS, .375	53
390	80142	WASHER, FLAT, USS, .375	53
30	118-1	WASHER, LOCK, .250	15
60	118-1	WASHER, LOCK, .250	15
130	118-1	WASHER, LOCK, .250	71
210	118-1	WASHER, LOCK, .250	11
300	118-1	WASHER, LOCK, .250	13
30	118-2	WASHER, LOCK, .312	35
120	118-2	WASHER, LOCK, .312	59
250	118-2	WASHER, LOCK, .312	11
30	118-3	WASHER, LOCK, .375	7, 49, 69
110	118-3	WASHER, LOCK, .375	35
120	118-3	WASHER, LOCK, .375	33
150	118-3	WASHER, LOCK, .375	35
160	118-3	WASHER, LOCK, .375	71
240	118-3	WASHER, LOCK, .375	27
300	118-3	WASHER, LOCK, .375	27
60	118-5	WASHER, LOCK, .500	61
70	118-5	WASHER, LOCK, .500	35
80	118-5	WASHER, LOCK, .500	9
110	118-5	WASHER, LOCK, .500	61, 65
130	118-5	WASHER, LOCK, .500	9, 67
200	118-5	WASHER, LOCK, .500	27
150	118-6	WASHER, LOCK, .562	35
30	118-7	WASHER, LOCK, .625	51
30	118-M10	WASHER, LOCK, 10MM	43, 45, 47

Section 5

ALPHABETICAL INDEX



ITEM NO.	PART NO.	DESCRIPTION	IPL PG.
80	118-M10	WASHER, LOCK, 10MM	43, 45, 47
110	118-M10	WASHER, LOCK, 10MM	43, 45, 47
420	118-M10	WASHER, LOCK, 10MM	53
10	984814	WASHER, VIBRATION ISOLATOR	55
130	983891	WEAR PLATE, FRONT WHEEL LIFT	41
20	983872	WEAR PLATE, REAR WHEEL LIFT	39
60	983872	WEAR PLATE, REAR WHEEL LIFT	39
150	983895	WHEEL LIFT, FRONT	41
80	983886	WHEEL LIFT, LEFT REAR, W/M	39
40	983875	WHEEL LIFT, RIGHT REAR, W/M	39



Sauer-Danfoss
US Company
All Products

Warranty
Policies and
Procedures

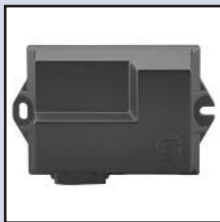



Sauer-Danfoss (US) Company All Product Warranty Policies and Procedures

WARRANTY

Sauer-Danfoss (US) Company ("Sauer-Danfoss") warrants for the applicable Warranty Period referred to below to the original equipment manufacturer or authorized distributor purchasing a Sauer-Danfoss Product ("Buyer") that the product will be free from defects in material and workmanship at the time of shipment from Sauer-Danfoss, and will conform to the drawings and specifications that apply to the product under Sauer-Danfoss' sale agreement with Buyer.

Duration of warranty is printed in the section "WARRANTY PERIODS" (the "Warranty Period"). During the Warranty Period, Sauer-Danfoss shall repair or replace those products or their parts found by Sauer-Danfoss to be defective in material or workmanship at time of original shipment, provided that Sauer-Danfoss or its authorized representative is first advised in writing within the applicable Warranty Period of Buyer's contention of such defect, and that the product or, if applicable, the part in question is made available for inspection by Sauer-Danfoss or its authorized representative.

To facilitate inspection, Sauer-Danfoss may request return of the product and/or part Buyer contends to be defective. If so requested, Buyer will return the item to a Sauer-Danfoss Authorized Service Center or Factory Repair Facility ("Service Center").

Product or parts failures or malfunctions that are not attributable to defects in material and/or workmanship, and which are not covered by the said warranty include, but are not limited to:

- Inadequate, contaminated, or improper fluid.
- Accident, abuse, or neglect.
- Stripped keyways, or splines stripped or worn on external shaft end.
- Improper mounting of external pulleys, gears, etc.
- Operating above those speeds, pressures, or temperatures recommended by Sauer-Danfoss.
- Operating with improper electrical inputs (voltage, polarity, current, etc.).
- Repairs by personnel other than as authorized by Sauer-Danfoss.
- Use of the product in a manner or for a purpose not originally intended for by Sauer-Danfoss.
- Use of parts other than Genuine Sauer-Danfoss Parts in any repairs.

Sauer-Danfoss shall not be liable for labor costs or any other expenses incurred in removing or reinstalling products or parts.

THE WARRANTIES SET FORTH HEREIN ARE IN LIEU OF AND TO THE EXCLUSION OF ALL OTHER WARRANTIES, WHETHER EXPRESSED, IMPLIED, OR STATUTORY OR OTHERWISE, INCLUDING SPECIFICALLY, BUT NOT BY WAY OF LIMITATION, ANY IMPLIED WARRANTIES OF MERCHANTABILITY OR FITNESS FOR A PARTICULAR PURPOSE.

Sauer-Danfoss' liability, whether of warranty, negligence, or otherwise, is limited to the repair or replacement as herein provided or, at Sauer-Danfoss' sole option, to a refund of the purchase price. **THIS SHALL BE SAUER-DANFOSS' MAXIMUM LIABILITY AND UNDER NO CIRCUMSTANCES SHALL SAUER-DANFOSS BE LIABLE FOR ANY INDIRECT, SPECIAL, INCIDENTAL, CONSEQUENTIAL, OR OTHER SIMILAR DAMAGES FROM ANY SOURCE WHATSOEVER (INCLUDING, SPECIFICALLY, BUT NOT LIMITED TO LOSS OF PROFIT, LOSS OF BUSINESS, OR ANY OTHER FINANCIAL LOSS BY BUYER OR ANY THIRD PARTY).**

If Buyer grants warranty on Sauer-Danfoss products of greater scope than the warranties provided by Sauer-Danfoss herein, or extends any Warranty Period beyond the applicable period described in "WARRANTY PERIODS," Buyer does so at its sole risk and expense. Buyer will indemnify and hold Sauer-Danfoss harmless from any claims of any party based on such greater warranty or period, and any expenses incurred in the defense of such claims. This warranty only applies to original-equipment manufacturers or authorized distributors, and by its terms does not extend to any person buying the product for personal, family, or household use. If Buyer extends its own warranty to its customer, and if the *Magnuson-Moss Warranty Improvement Act* (Pub. L. 93-637) or similar state laws should apply, Buyer assumes all responsibility for compliance with such laws and will indemnify and hold Sauer-Danfoss harmless from any claims of any party based on a violation of such laws and any expenses incurred in the defense of any such claims.



Sauer-Danfoss (US) Company All Product Warranty Policies and Procedures

WARRANTY PERIODS

New products

The Warranty Period is limited to the earlier of:

- (i) 24 consecutive months (2 years) from the date of first use of the product, or
- (ii) 36 consecutive months (3 years) from the date of original shipment of the product from Sauer-Danfoss.

Rebuilt products

If a product is rebuilt by a Service Center during the original new product Warranty Period, warranty on the rebuilt item shall be as set forth herein and shall continue for the balance of the original Warranty Period, or for a period equal to 50% of the original new product Warranty Period, whichever is later.

Service parts

The Warranty Period for Service Parts shall be 12 consecutive months (1 year) from date of original shipment of such service parts from Sauer-Danfoss.

REPAIR PROCEDURES

- A. Major warranty repairs must be made by a Service Center and shall be obtained in accordance with all procedures set forth herein. To reduce unnecessary machine down time and freight costs, minor repairs may be performed in the field per the procedures in the applicable Sauer-Danfoss Service Manual, without affecting the product's warranty.
- B. By forwarding a product to a Service Center for repair, Buyer acknowledges the Service Center's expertise and technical ability to determine by inspection whether a product was defective in material and/or workmanship when shipped from Sauer-Danfoss.
- C. If upon receipt and inspection of the item, Sauer-Danfoss, in its sole discretion, determines that the product or part is defective in materials or workmanship, Sauer-Danfoss will, upon request, reimburse Buyer for its reasonable charges in returning the item via surface transportation, and will repair or replace the product or part at no charge to Buyer. If a product is returned to Sauer-Danfoss for warranty consideration and upon inspection and testing is found not to be defective, an inspection or repair charge will be assessed for this examination or repair even though the product is within the Warranty Period.
- D. A Purchase Order must be supplied to the Service Center for all products returned for repair.
- E. Damage or losses incurred during shipping and handling of products is the responsibility of Buyer.
- F. Products submitted for repair may be updated at the Service Center's sole discretion, but no changes will be made that will detrimentally affect the form, fit, or function of the product. Sauer-Danfoss reserves the right to make changes in the design of its products at any time without incurring any obligation to make equivalent changes in products previously manufactured or shipped.
- G. The Service Center has no responsibility for the return of customer's fittings, couplings, hoses, etc. attached to or included with products.
- H. Upon inspection or repair of each product, an "Inspection Report" will be completed by the Service Center. This document reports the reason for malfunction and the condition of the hardware. A copy is available to Buyer upon request.
- I. Products returned containing other than "Genuine" Sauer-Danfoss Parts will have those parts replaced with Genuine Sauer-Danfoss Parts. A charge will be assessed for all non-Sauer-Danfoss Parts replaced during repair.
- J. A "Rebuilt" tag or stamp will be attached to each repaired product. This applies to all products that are repaired except for Buyer production line rejects. Production line rejects will be repaired and returned without this tag or stamp.
- K. All repaired products will be tested and painted or refinished. The product will be assigned a new serial number or date code, except for Buyer production line rejects, which will retain original serial number.
- L. The Service Center may, at its option, "Drop Ship" or ship to a location other than Buyer's place of business if requested by Buyer.



OUR PRODUCTS

Hydrostatic transmissions
Hydraulic power steering
Electric power steering
Closed and open circuit axial piston pumps and motors
Gear pumps and motors
Bent axis motors
Radial piston motors
Orbital motors
Transit mixer drives
Planetary compact gears
Proportional valves
Directional spool valves
Cartridge valves
Hydraulic integrated circuits
Hydrostatic transaxles
Integrated systems
Fan drive systems
Electrohydraulic controls
Digital electronics and software
Battery powered inverter
Sensors

Sauer-Danfoss Hydraulic Power Systems – Market Leaders Worldwide

Sauer-Danfoss is a comprehensive supplier providing complete systems to the global mobile market.

Sauer-Danfoss serves markets such as agriculture, construction, road building, material handling, municipal, forestry, turf care, and many others.

We offer our customers optimum solutions for their needs and develop new products and systems in close cooperation and partnership with them.

Sauer-Danfoss specializes in integrating a full range of system components to provide vehicle designers with the most advanced total system design.

Sauer-Danfoss provides comprehensive worldwide service for its products through an extensive network of Authorized Service Centers strategically located in all parts of the world.

Sauer-Danfoss (US) Company
2800 East 13th Street
Ames, IA 50010, USA
Phone: +1 515 239-6000, Fax: +1 515 239 6618

Sauer-Danfoss (Neumünster) GmbH & Co. OHG
Postfach 2460, D-24531 Neumünster
Krokamp 35, D-24539 Neumünster, Germany
Phone +49 4321 871-0, Fax: +49 4321 871 122

Sauer-Danfoss (Nordborg) A/S
DK-6430 Nordborg, Denmark
Phone: +45 7488 4444, Fax: +45 7488 4400



Series 45
Frame K and L
Open Circuit
Axial Piston Pumps

Service Manual

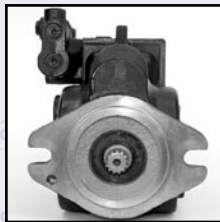

Displ

Pis

plate

Tapered Roller
Bearing

Tapered Roller
Bearing

Valve Plate

Cylinder Block Kit

Shaft Seal

INTRODUCTION

Using this manual4
 Safety precautions4
 Unintended machine movement.....4
 Flammable cleaning solvents4
 Fluid under pressure4
 Personal safety4
 Symbols used in Sauer-Danfoss literature.....5
 General description6
 Pump and control sectional view6
 The system circuit7
 Pictorial circuit diagram.....7

TECHNICAL SPECIFICATIONS

General specifications8
 Type of mounting.....8
 Auxiliary mounting pad options.....8
 Control options8
 Port options.....8
 Direction of rotation.....8
 Installation position.....8
 Technical specifications8
 Ratings8
 Hydraulic parameters.....9
 Inlet pressure9
 Pressure compensator valve setting9
 Case pressure.....9
 Hydraulic fluid9
 Temperature range19
 Fluid viscosity9
 Viscosity limits.....9
 Filtration9

FEATURES

Displacement limiter.....10
 Auxiliary mounting pads10
 Input shafts.....10
 Displacement limiter10
 Auxiliary mounting pads.....10
 Control options12
 Cross-section PC control.....12
 Operation12
 General.....12
 PC control.....12
 Cross-section pump12
 Cross-section LS control13
 LS control13
 Typical load-sensing control valve.....13

© 2001 Sauer-Danfoss. Sauer-Danfoss accepts no responsibility for possible errors in catalogs, brochures and other printed material. Sauer-Danfoss reserves the right to alter its products without prior notice. This also applies to products already ordered provided that such alterations can be made without subsequent changes being necessary in specifications already agreed. All trademarks in this material are properties of their respective owners. Sauer-Danfoss and the Sauer-Danfoss logotype are trademarks of the Sauer-Danfoss Group. All rights reserved. Printed in U.S.A. (0402H)

PRESSURE MEASUREMENT	Port locations and gauge installation	14
	Required tools	14
	Gauge and port information.....	14
	Gauge port locations, radial ported units	14
	Gauge port locations, axial ported units	14
INITIAL START-UP PROCEDURES	General	15
	Start-up procedure	15
FLUID AND FILTER MAINTENANCE	Recommendations.....	16
	Fluid and filter change interval	16
TROUBLESHOOTING	Excessive noise and / or vibration	17
	Actuator response is sluggish.....	17
	System operating hot	18
	Low pump output flow	18
	Pressure or flow instability	18
	System pressure not reaching PC setting.....	19
	High inlet vacuum.....	19
ADJUSTMENTS	PC control.....	20
	PC control adjustment	20
	LS / PC control	21
	LS control adjustment	21
MINOR REPAIR	Shaft seal replacement.....	22
	Removal	22
	Installation	22
	Shaft seal and retaining ring.....	22
	Auxiliary pads	23
	Removal	23
	Auxiliary mounting pads.....	23
	Installation	23
	Control.....	24
	Disassembly	24
	Inspection	24
	Control assembly	24
	Reassembly.....	25
Control assembly	25	
Plug and fitting sizes and torques.....	26	
Plug locations, sizes, and torques	26	

USING THIS MANUAL

This manual includes information for the normal operation, maintenance, and service of the Series 45 frame K and L open circuit pumps. The manual includes a description of the units and their individual components, troubleshooting information, adjustment instructions and minor repair procedures. Unit warranty obligations should not be affected if maintenance, adjustment and minor repairs are performed according to the procedures described in this manual.

Many service and adjustment activities can be performed without removing the unit from the vehicle or machine. However, adequate access to the unit must be available, and the unit must be thoroughly cleaned before beginning maintenance, adjustment, or repair activities. Since dirt and contamination are the greatest enemies of any type of hydraulic equipment, follow cleanliness requirements strictly. This is especially important when changing the system filter and when removing hoses or plumbing.

A worldwide network of Sauer-Danfoss **A**uthorized **S**ervice **C**enters (ASCs) is available should major repairs be needed. Contact any Sauer-Danfoss ASC for details. A list of all ASCs can be found in bulletin BLN-2-40527, or in brochure SAW (Ident. No. 698266), or you can locate your nearest ASC using the distributor locator at www.sauer-danfoss.com.

SAFETY PRECAUTIONS

Always consider safety precautions before beginning a service procedure. Protect yourself and others from injury. Take the following general precautions whenever servicing a hydraulic system.

Unintended machine movement

▲ WARNING

Unintended movement of the machine or mechanism may cause injury to the technician or bystanders. To protect against unintended movement, secure the machine or disable / disconnect the mechanism while servicing.

Flammable cleaning solvents

▲ WARNING

Some cleaning solvents are flammable. To avoid possible fire, do not use cleaning solvents in an area where a source of ignition may be present.

Fluid under pressure

▲ WARNING





























Escaping hydraulic fluid under pressure can have sufficient force to penetrate your skin causing serious injury and/or infection. This fluid may also be hot enough to cause burns. Use caution when dealing with hydraulic fluid under pressure. Relieve pressure in the system before removing hoses, fittings, gauges, or components. Never use your hand or any other body part to check for leaks in a pressurized line. Seek medical attention immediately if you are cut by hydraulic fluid.

Personal safety

▲ WARNING

Protect yourself from injury. Use proper safety equipment, including safety glasses, at all times.

**SYMBOLS USED IN
 SAUER-DANFOSS
 LITERATURE**

- | | | | |
|---|---|---|--|
|  | WARNING may result in injury |  | Tip, helpful suggestion |
|  | CAUTION may result in damage to product or property |  | Lubricate with hydraulic fluid |
|  | Reusable part |  | Apply grease / petroleum jelly |
|  | Non-reusable part, use a new part |  | Apply locking compound |
|  | Non-removable item |  | Inspect for wear or damage |
|  | Option – either part may exist |  | Clean area or part |
|  | Superseded – parts are not interchangeable |  | Be careful not to scratch or damage |
|  | Measurement required |  | Note correct orientation |
|  | Flatness specification |  | Mark orientation for reinstallation |
|  | Parallelism specification |  | Torque specification |
|  | External hex head |  | Press in – press fit |
|  | Internal hex head |  | Pull out with tool – press fit |
|  | Torx head |  | Cover splines with installation sleeve |
|  | O-ring boss port |  | Pressure measurement / gauge location or specification |

The symbols above can be found in the illustrations and text of this manual. They are intended to communicate helpful information at the point where it is most useful to the reader. In most instances, the appearance of the symbol itself denotes its meaning. The legend above is provided to define each symbol and explain its purpose.

GENERAL DESCRIPTION

Sauer-Danfoss Series 45 K and L frame open circuit piston pumps convert input torque into hydraulic power. Rotational force is transmitted through the input shaft to the cylinder block. The input shaft is supported by tapered roller bearings at the front and rear of the pump and is splined into the cylinder block. A lip-seal at the front end of the pump prevents leakage where the shaft exits the pump housing. The spinning cylinder block contains nine reciprocating pistons. Each piston has a brass slipper connected at one end by a ball joint. The slippers are held to the swashplate by the spring retainer and block spring. The block spring also holds the cylinder block to the valve plate. The reciprocating movement of the pistons occurs as the slippers slide against the inclined swashplate during rotation. Via the valve plate, one half of the cylinder block is connected to pump inlet and the other half to pump outlet. As each piston cycles in and out of its bore, fluid is drawn from the inlet and displaced to the outlet thereby imparting power into the system circuit. A small amount of fluid is allowed to “leak” from the cylinder block / valve plate and slipper / swashplate interfaces for lubrication and cooling. Case drain ports are provided to return this fluid to the reservoir.

The volume of fluid displaced into the system circuit is controlled by the angle of the swashplate. The swashplate is forced into an inclined position (into stroke) by the bias spring. The servo piston opposes the action of the bias spring forcing the swashplate out of stroke when hydraulic pressure in the control circuit rises above the spring force.

The pump control, by varying the pressure at the servo piston, controls the displacement of fluid in the system circuit. Controls designed for **P**ressure **C**ompensation (PC) or **L**oad **S**ensing (LS) are available. For a detailed description of control operation, refer to *Control options, operation*, page 12.

Pump and control sectional view

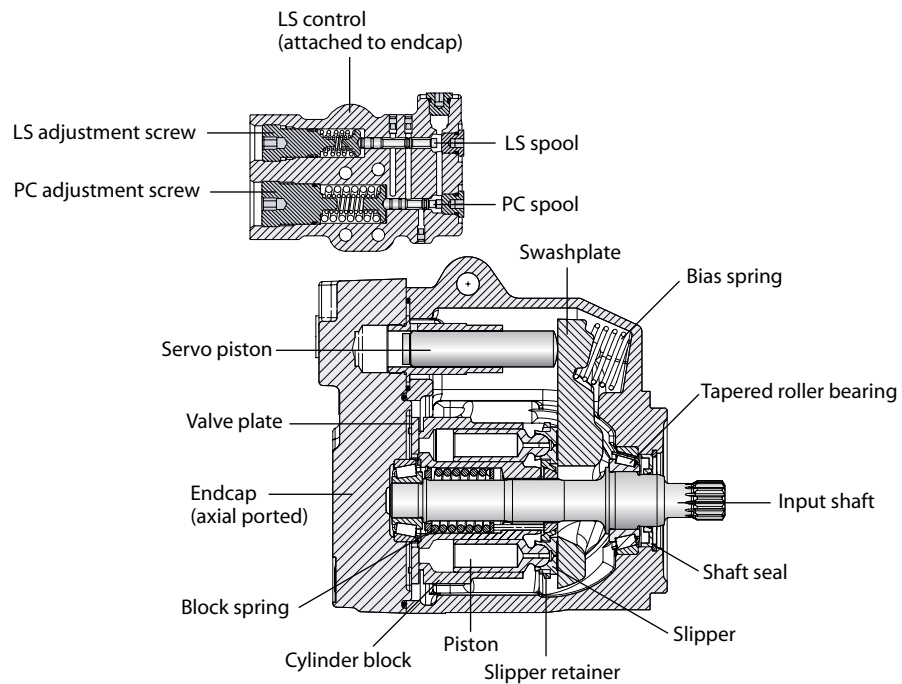

P101 659E

THE SYSTEM CIRCUIT

The pump receives fluid directly from the reservoir through the inlet line. A screen placed in the inlet protects the pump from large contaminants. The output of the pump is directed to a PVG-32 multi-section load sensing directional control valve which directs fluid to the actuators in the system. Fluid returning from the system is cooled by a heat exchanger and cleaned by a filter before returning to the reservoir.

The speed of the actuators in the system depends on the volume of fluid being provided by the pump. The operating pressure varies depending on actuator load, but is limited to an adjustable maximum setting by the PC section of the pump control and by a system relief valve integrated into the side module of the PVG valve.

The position of the PVG valve sets the demand for flow in the system and communicates this to the pump control by means of a hydraulic signal (load sense signal). The pump will provide as much flow to the system as it demands¹ while limiting the maximum pressure. Therefore flow and pressure in the system are compensated to meet requirements.

Pictorial circuit diagram

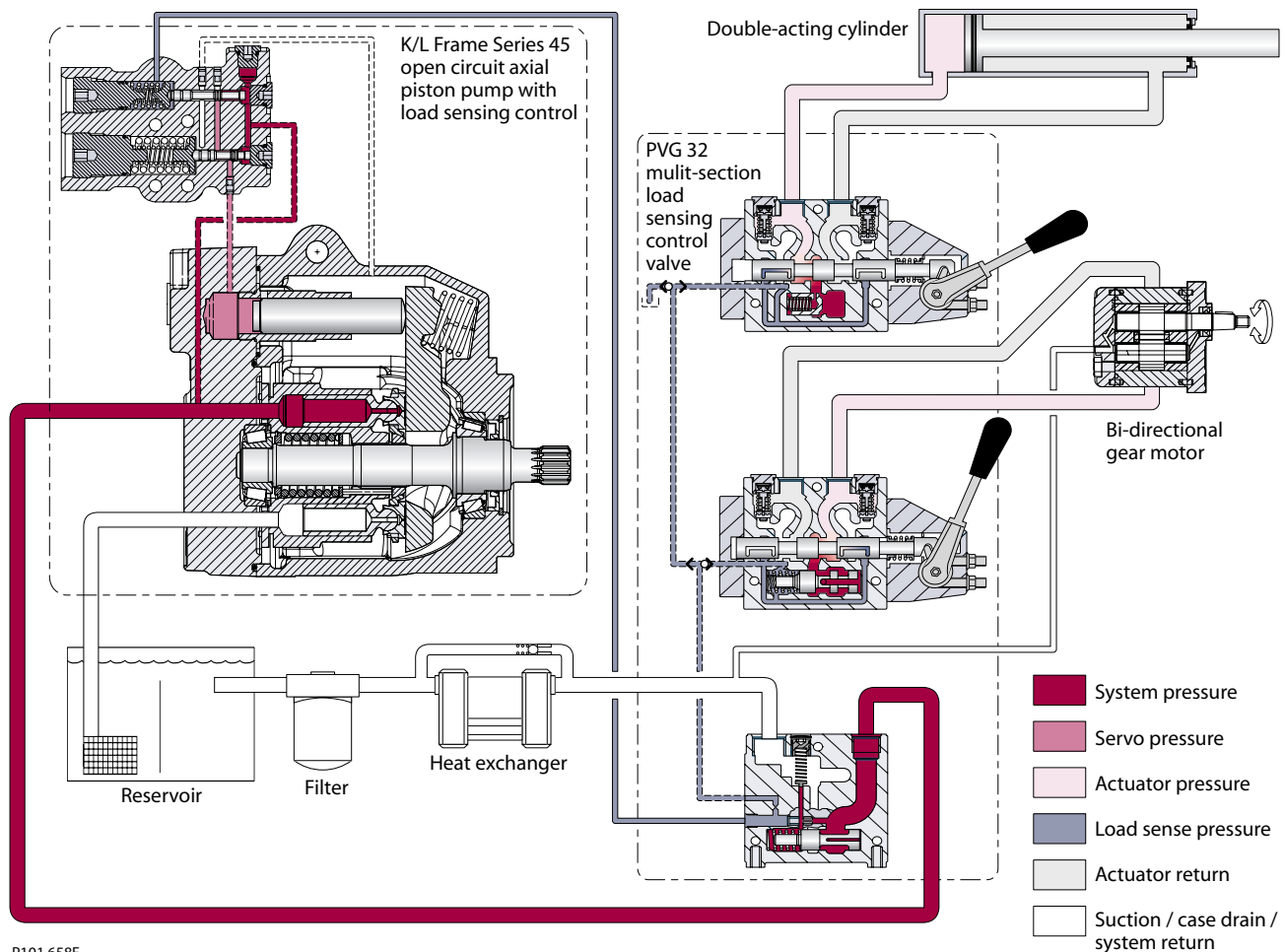

P101 658E

¹ Full available flow is a function of pump displacement, operating speed, and efficiency. Refer to *Series 45 Axial Piston Open Circuit Pumps Technical Information, BLN-10128* for details.

GENERAL SPECIFICATIONS

Type of mounting

SAE-B mounting flange.

Auxiliary mounting pad options

SAE-A, SAE-B, or SAE-B-B

Control options

PC: Pressure Compensator

LS: Load Sensing (with PC)

Port options

Inlet and system ports: SAE flanged ports, code 61 or O-ring boss ports.
 Axial (end) ports or radial (side) ports.

All other ports: SAE straight thread O-ring boss.

Direction of rotation

Clockwise or counterclockwise.

Installation position

Installation position is discretionary. To satisfy inlet pressure conditions, it is recommended that the pump always be located below the lowest level of hydraulic fluid in the reservoir. The housing must always be filled with hydraulic fluid.

Technical specifications

Ratings

Specification		Unit	Frame L		Frame K	
Displacement		cm ³ [in ³]	25 [1.53]	30 [1.83]	38 [2.32]	45 [2.75]
Input Speed	Minimum	min ⁻¹ (rpm)	500	500	500	500
	Rated		3200	3200	2650	2650
	Maximum		3600**	3600**	2800**	2800**
Maximum (peak) working pressure		bar [psi]	350 [5075]	300 [4350]	350 [5075]	300 [4350]
Continuous working pressure			260 [3770]	210 [3045]	260 [3770]	210 [3045]
Flow at rated speed		l/min [gal/min]	76.2 [20.3]	90.0 [24.0]	108.3 [28.9]	126.0 [33.6]
Theoretical input torque at maximum displacement		N•m/bar [lbf•in/1000psi]	0.395 [243]	0.477 [291]	0.605 [369]	0.716 [437]
Mass moment of inertia of internal rotating components		kg•m ² [lbf•ft ²]	0.0016 [0.037]	0.0015 [0.035]	0.0017 [0.040]	0.0020 [0.047]
Weight	Axial ports	kg [lbf]	19 [42]	19 [42]	19 [42]	19 [42]
	Radial ports		24 [53]	24 [53]	24 [53]	24 [53]

**HYDRAULIC
 PARAMETERS**

Inlet pressure

Minimum pressure, continuous = 0.8 bar absolute [23.2 in Hg]
 (at reduced maximum pump speed)

Minimum pressure, cold start = 0.5 bar absolute [14.8 in Hg]

Pressure compensator valve setting

Minimum: 100 bar [1450 psi]
 Maximum: 260 bar [3770 psi]

Case pressure

Maximum continuous: 0.5 bar [7 psi] Above inlet
 Intermittent: 2 bar [29 psi] Cold start

Hydraulic fluid

Refer to Sauer-Danfoss publication *Fluids and Filtration* BLN-9887 or 520L0463. For information on biodegradable fluids refer to *Biodegradable Hydraulic Fluids* 520L0465. See *Fluid and filter maintenance*, page 16 for recommended fluid and filter change intervals.

Temperature range¹

Intermittent (cold start): - 40° C [- 40° F]
 Continuous: 82° C [180° F]
 Maximum:² 104° C [220° F]

Fluid viscosity

Viscosity limits

Rating		mm ² /s (cSt) [SUS]
v continuous	minimum	9 [58]
	maximum	110 [500]
v intermittent	minimum	6.4 [47]
	maximum (cold start)	1000 [4700]

Filtration

Required cleanliness level: ISO 4406 Class 18/13 or better. Refer to Sauer-Danfoss publications *Fluids and Filtration* BLN-9887 or 520L0463 and *Design Guidelines for Selecting and Maintaining the Required Hydraulic Fluid Cleanliness* 520L0465. See *Fluid and filter maintenance*, page 16 for recommended fluid and filter change intervals.

¹ Hydraulic fluid viscosity must be maintained within the prescribed limits.

² As measured at the hottest point in the system, e.g. drain line.

DISPLACEMENT LIMITER

Frame K and L Series 45 pumps are available with an optional maximum displacement limiter. If installed, this longer servo piston will limit the maximum displacement to 92%. This displacement limiter is not adjustable.

Displacement limiter

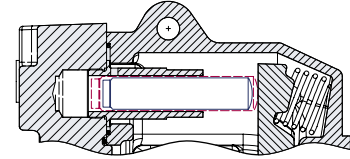

P101 660

AUXILIARY MOUNTING PADS

Auxiliary mounting pads are available for all radial ported Series 45 pumps. These pads are typically used for mounting auxiliary hydraulic pumps.

Since the auxiliary pad operates under case pressure, an O-ring must be used to seal the auxiliary pump mounting flange to the pad. The drive coupling is lubricated by oil from the main pump case. For details refer to *Series 45 Axial Piston Open Circuit Pumps Technical Information* BLN-10128.

Auxiliary mounting pads

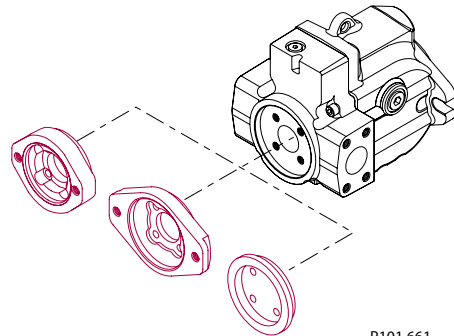

P101 661

INPUT SHAFTS

Series 45 K and L frame pumps are available with a variety of splined, straight keyed, and tapered end shafts. For information on shafts refer to *Series 45 Axial Piston Open Circuit Pumps Technical Information* BLN-10128.

CONTROL OPTIONS

The Series 45 Frames K and L have two possible control options, a **Load Sensing (LS)** control with **Pressure Compensator (PC)** or a **PC only** control.

Operation
General

The bias spring (1) acts at all times to push the swashplate (2) to maximum angle causing the pump to stroke. The servo piston (3) acts against the bias spring to reduce the swashplate angle causing the pump to de-stroke. Swashplate angle determines pump outlet flow. The pump control, depending on conditions in the system circuit, sets swashplate angle by metering system pressure to the servo piston.

Cross-section pump

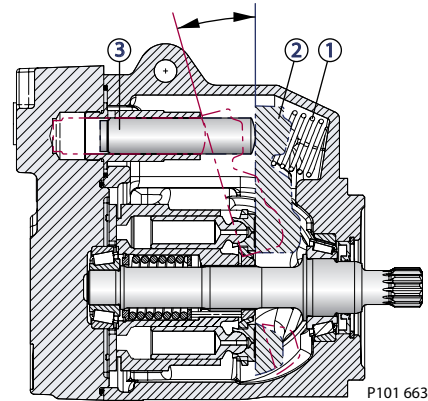

Bias spring and servo piston set swashplate position

PC control

The PC control is designed to maintain a constant pressure in the hydraulic circuit as flow varies. The PC control modulates pump flow accordingly to maintain system pressure at the PC setting as defined by the PC adjustment screw (4) and spring (5).

Cross-section PC control

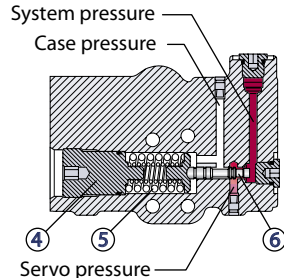

PC spool shifts to port system pressure to servo piston

When system pressure, acting on the non-spring end of the PC spool (6), overcomes the force of the PC spring, the spool shifts porting system pressure to the servo piston and the swashplate angle decreases. When system pressure drops below the PC setting, the PC spring shifts the spool in the opposite direction connecting the servo piston to pump case and the swashplate angle increases. The swashplate is maintained at whatever angle is required to keep system pressure at the PC setting.

**CONTROL OPTIONS
(continued)**

LS control

The LS control is designed to match pump flow with system demand. The flow demand of the system is sensed by the LS control as a pressure drop across the **External Control Valve (ECV)**. As the ECV opens and closes, the pressure delta across the valve changes. When opening, the delta decreases. When closing, the delta increases. The LS control then increases or decreases pump flow to the system until the pressure delta becomes equal to the LS setting as defined by the LS adjustment screw (7) and spring (8).

Typical load-sensing control valve

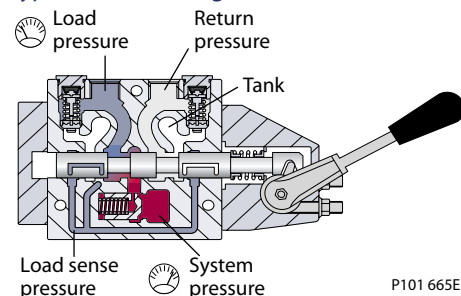

Pressure drop across external control valve defines system demand

Cross-section LS control

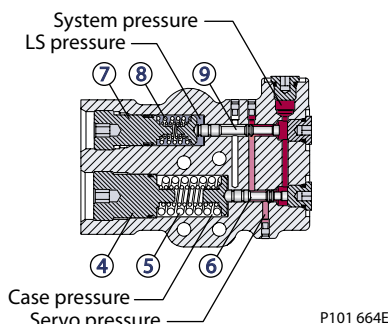

LS spool shifts to port system pressure to servo piston

The LS control consists of two spool valves that connect the servo piston either to pump case or system pressure. The PC spool (6) controls the pressure-compensating function of the control as described in the previous section. The LS spool (9) controls the load-sensing function. The PC spool has priority over the LS spool.

Via internal porting, system pressure (upstream of ECV) is applied to the non-spring end of the LS spool and via hydraulic line connected at port X, LS pressure (downstream of ECV) is applied

to the spring end. This arrangement allows the LS spool to act on the delta between system pressure and LS pressure. The LS spring sets the threshold of operation (LS setting).

Because the swashplate is biased to maximum angle, the pump attempts to deliver full flow to the hydraulic system. When the flow being delivered exceeds demand, the pressure delta across the ECV is great enough to overcome spring force and shift the LS spool porting system pressure to the servo piston. The pump de-strokes reducing flow until the delta across the ECV becomes equal to the LS setting. When flow being delivered is less than demand, the delta across the ECV drops below the LS setting and the LS spring shifts the spool connecting the servo piston to pump case. The pump strokes increasing flow until the delta across the ECV becomes equal to the LS setting.

When the external control valve is placed in neutral, it connects the LS signal line to drain. With no LS pressure acting on the non-spring end of the LS spool, the pump adjusts stroke to whatever position necessary to maintain system pressure at the LS setting. The pump is now in standby mode.

Because of the series arrangement of the LS and PC spools, the PC spool will override the LS spool. If at any time system pressure reaches the PC setting, the PC spool will shift blocking the passage that connects the LS spool with the servo piston and porting system pressure to the servo piston causing the pump to de-stroke.

REQUIRED TOOLS

The service procedures described in this manual can be performed using common mechanic's hand tools. Special tools, if required are shown. Calibrate pressure gauges frequently to ensure accuracy. Use snubbers to protect gauges.

PORT LOCATIONS AND GAUGE INSTALLATION

Gauge port locations are shown below. Recommended pressure gauges and fittings are detailed in the table.

Gauge and port information

Port	Purpose	Range of gauge	Fitting
M2	System pressure	0-300 bar or [0-5000 psi]	7/16 - 20 o-ring fitting
M4	Servo pressure	0-300 bar or [0-5000 psi]	7/16 - 20 o-ring fitting
L1, L2	Case pressure	0-10 bar or [0-100 psi]	7/8 - 14 o-ring fitting
X1	LS signal	0-300 bar or [0-5000 psi]	7/16 - 20 o-ring fitting (tee into LS signal line)

Gauge port locations, axial ported units

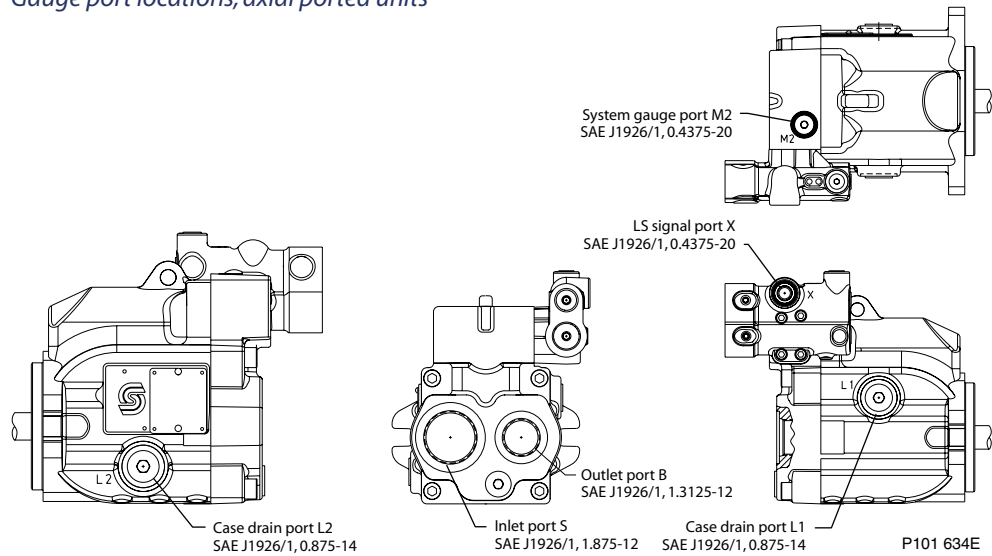

Gauge port locations, radial ported units

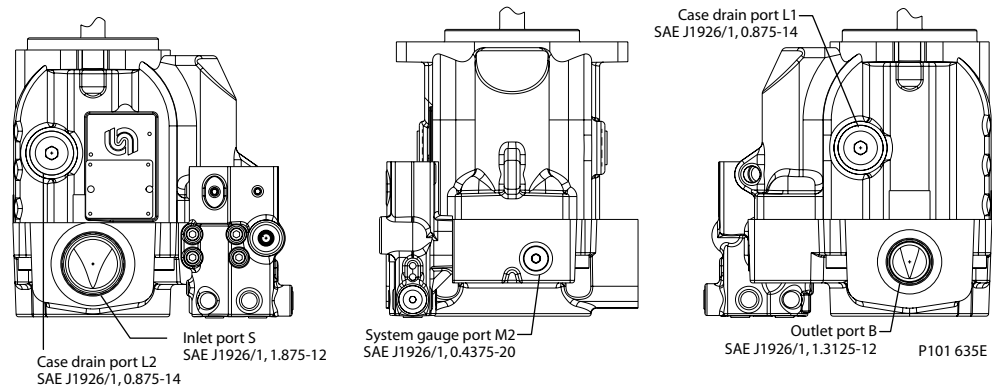

GENERAL

Follow this procedure when starting-up a new Series 45 installation or when restarting an installation in which the pump has been removed.

▲WARNING

Unintended movement of the machine or mechanism may cause injury to the technician or bystanders. To protect against unintended movement, secure the machine or disable / disconnect the mechanism while servicing.

Prior to installing the pump, inspect for damage incurred during shipping. Make certain all system components (reservoir, hoses, valves, fittings, heat exchanger, etc.) are clean prior to filling with fluid.

START-UP PROCEDURE

ⓘ CAUTION

Incorrect shaft alignment may result in damage to drive shaft, bearings, or seal which can cause external oil leakage.

1. Connect the pump to the prime mover. Ensure that pump shaft is properly aligned with the shaft of the prime mover. ⓘ
2. Fill the reservoir with recommended hydraulic fluid. Always filter fluid through a 10 micron filter pouring into the reservoir. Never reuse hydraulic fluid.
3. Fill the main pump housing with clean hydraulic fluid. Pour filtered oil directly into the upper most case drain port.
4. Fill the inlet line leading from the pump to the reservoir. Check the inlet line for properly tightened fittings and be certain it is free of restrictions and air leaks.
5. To ensure the pump stays filled with oil, install the case drain line in the upper most case drain port.
6. Install a gauge at port M2 to monitor system pressure during start up.

Note: Follow recommendations in the vehicle / machine operator's manual for prime mover start up procedures.

7. While watching the pressure gauge installed at M2, jog the prime mover or run at the lowest possible speed until system pressure builds to normal levels (minimum 11 bar [160psi]). Once system pressure is established, increase to full operating speed. If system pressure is not maintained, shut down the prime mover, determine cause, and take corrective action. Refer to *Troubleshooting*, page 17.
8. Operate the hydraulic system for at least fifteen minutes under light load conditions.
9. Check and adjust control settings as necessary after installation. Refer to *Adjustments*, page 20.
10. Shut down the prime mover and remove the pressure gauge. Replace plug at port M2.
11. Check the fluid level in the reservoir; add clean filtered fluid if necessary.

The pump is now ready for operation.

RECOMMENDATIONS

To ensure optimum life of Series 45 products, perform regular maintenance of the fluid and filter. Contaminated fluid is the main cause of unit failure. Take care to maintain fluid cleanliness when servicing.

Check the reservoir daily for proper fluid level, the presence of water, and rancid fluid odor. Water in the fluid may be noted by a cloudy or milky appearance or free water in the bottom of the reservoir. Rancid odor indicates the fluid has been exposed to excessive heat. Change the fluid immediately if these conditions occur. Correct the problem immediately.

Change the fluid and filter per the vehicle / machine manufacturer's recommendations or at these intervals:

Change the fluid more frequently if it becomes contaminated with foreign matter (dirt, water, grease, etc.) or if the fluid is subjected to temperature levels greater than the recommended maximum.

Fluid and filter change interval

Reservoir Type	Maximum Change Interval
Sealed	2000 Hours
Breather	500 Hours

Note: Dispose of used hydraulic fluid properly. Never reuse hydraulic fluid.

Change filters whenever the fluid is changed or when the filter indicator shows that it is necessary to change the filter. Replace all fluid lost during filter change.

**EXCESSIVE NOISE AND /
OR VIBRATION**

Item	Description	Action
Check fluid level in reservoir.	Insufficient hydraulic fluid will cause cavitation.	Fill the reservoir to proper level.
Check for air in system.	Air in system will cause noisy, erratic control.	Purge air and tighten fittings. Check inlet for leaks.
Check pump inlet pressure / vacuum.	Improper inlet conditions will cause erratic behavior and low output flow.	Correct pump inlet pressure / vacuum conditions. Refer to <i>Hydraulic parameters</i> , page 9.
Inspect shaft couplings.	A loose or incorrect shaft coupling will cause excessive noise and/or vibration.	Repair or replace coupling and ensure that correct coupling is being used.
Check shaft alignment.	Misaligned shafts will create excessive noise and/or vibration.	Correct shaft misalignment.
Hydraulic fluid viscosity above acceptable limits.	Hydraulic fluid viscosity above acceptable limits or low fluid temperature will not allow the pump to fill or control to operate properly.	Allow system to warm up before operation or use fluid with the appropriate viscosity grade for expected operating temperatures. See <i>Hydraulic Fluids, Series 45 Technical Information Manual</i> , BLN-10128.

**ACTUATOR RESPONSE IS
SLUGGISH**

Item	Description	Action
Check external system relief valve setting.	Low external relief valve setting will slow down system.	Adjust external relief valve setting per manufacturer's recommendations. External relief setting must be above PC setting for proper operation.
Check PC and LS control setting.	Low PC setting will prevent the pump from achieving full stroke. Low LS setting will limit output flow.	Adjust PC and LS setting. Refer to <i>Adjustments</i> , page 20.
Check LS control signal pressures.	Incorrect LS signal will not allow pump to operate correctly.	Inspect system, ensure that proper LS signal is transmitted to the pump.
Internal system leaks.	Worn internal parts will not allow the pump to operate properly.	Refer to Authorized Service Center for repairs as required.
Hydraulic fluid viscosity above acceptable limits.	Hydraulic fluid viscosity above acceptable limits or low fluid temperature will not allow the pump to fill or control to operate properly.	Allow system to warm up before operation or use fluid with the appropriate viscosity grade for expected operating temperatures. See <i>Hydraulic Fluids, Series 45 Technical Information Manual</i> , BLN-10128.
Check external system valving.	Malfunctioning valving may not allow system to respond properly.	Repair or replace system valving as required.
Check pump case pressure.	High case pressure will cause the system to be sluggish.	Correct case drain line restrictions.
Check pump inlet pressure / vacuum.	High inlet vacuum will cause low output flow.	Correct inlet pressure conditions.

SYSTEM OPERATING HOT

Item	Description	Action
Check fluid level in reservoir.	Insufficient volume of hydraulic fluid will not meet cooling demands of system.	Fill reservoir to proper level. Verify proper size of reservoir.
Inspect heat exchanger. Check air flow and input air temperature for the heat exchanger.	Insufficient air flow, high input air temperature, or undersized heat exchanger will not meet cooling demands of the system.	Clean, repair, or replace heat exchanger as required. Verify proper size of heat exchanger.
Check external system relief valve setting.	Fluid passing through relief valve adds heat to system.	Adjust external system relief valve setting per manufacturer's recommendations. External relief valve setting must be above PC setting for proper operation.
Check pump inlet pressure / vacuum.	High inlet vacuum adds heat to system.	Correct inlet pressure / vacuum conditions.

LOW PUMP OUTPUT FLOW

Item	Description	Action
Check fluid level in reservoir.	Insufficient hydraulic fluid will limit output flow and cause internal damage to pump.	Fill the reservoir to proper level.
Hydraulic fluid viscosity above acceptable limits.	Fluid viscosity above acceptable limits or low fluid temperature will not allow the pump to fill or control to operate properly.	Allow system to warm up before operation or use fluid with the appropriate viscosity grade for expected operating temperatures. See <i>Hydraulic fluids, Series 45 Technical Information Manual</i> , BLN-10128.
Check external system relief valve setting.	External relief valve set below PC setting will cause low output flow.	Adjust external relief valve per manufacturer's recommendation. External relief valve setting must be above PC setting for proper operation.
Check PC and LS control setting.	Low PC setting will prevent the pump from achieving full stroke. Low LS setting will limit output flow.	Adjust PC and LS setting. Refer to <i>Adjustments</i> , page 20.
Check pump inlet pressure / vacuum.	High inlet vacuum will cause low output flow.	Correct inlet pressure conditions.
Check input speed.	Low input speeds decrease flow.	Adjust input speed.
Check pump rotation.	Incorrect rotational configuration will cause low flow.	Use pump with appropriate rotational configuration.

PRESSURE OR FLOW INSTABILITY

Item	Description	Action
Check for air in system.	Air in system will cause erratic operation.	Activate PC, allowing system to bleed air. Check inlet line for leaks and eliminate source of air ingress.
Check control spools.	Sticking control spools will cause erratic operation.	Inspect spools for free movement in bore. Clean or replace as needed.

**PRESSURE OR FLOW
INSTABILITY (continued)**

Item	Description	Action
Check LS setting.	Low LS setting may cause instability.	Adjust LS setting to proper level. See <i>Adjustments</i> , page 20.
Check LS signal line.	Blocked LS signal line will interfere with proper LS operation.	Remove blockage.
Check external relief valve and PC setting.	Insufficient pressure differential between PC setting and external relief valve.	Adjust external relief valve or PC control settings to appropriate level. Relief valve setting must be above PC setting for proper operation.
Check external relief valve.	Chattering external relief valve may cause unstable feedback to pump control.	Adjust or replace relief valve.

**SYSTEM PRESSURE NOT
REACHING PC SETTING**

Item	Description	Action
Check PC control setting.	System pressure will not rise above PC setting.	Adjust PC to appropriate setting. Refer to <i>Adjustments</i> , page 20.
Check external relief valve.	External relief valve setting below PC setting will prevent pressure compensation.	Adjust external relief valve per manufacturer's recommendations. External relief valve must be set above PC setting for proper operation.
Inspect PC control spring.	Broken, damaged, or missing spring will cause erratic operation.	Replace spring as required.
Inspect PC spool for wear.	Wear of the PC spool will cause internal leakage in the control.	Replace the spool as required.
Inspect PC spool for proper orientation.	Improper orientation will result in poor operation.	Correct orientation of spool.
Check PC control for contamination.	Contamination may interfere with movement of the PC Spool.	Clean PC control components, take appropriate action to eliminate contamination.

HIGH INLET VACUUM

⚠ CAUTION
High inlet vacuum causes cavitation which can damage internal pump components.

Item	Description	Action
Check fluid temperature.	Low temperature increases viscosity. High fluid viscosity causes high inlet vacuum.	Allow system to warm up before operation.
Inspect inlet screen.	Blocked or restricted inlet screen will cause high inlet vacuum.	Clean screen / remove blockage.
Check inlet piping.	Too many fittings, bends, or long piping will cause high inlet vacuum.	Eliminate fittings to make path more direct.
Hydraulic fluid viscosity above acceptable limits.	High fluid viscosity causes high inlet vacuum.	Select fluid with appropriate viscosity for expected operating temperature. See <i>Hydraulic fluids, Series 45 Technical Information Manual</i> , BLN-10128.

PC CONTROL

PC setting is indicated in the pump model code. Refer to the *Series 45 Open Circuit Axial Piston Pumps Technical Information Manual*, BLN-10128, for more information.

⚠ WARNING

Escaping hydraulic fluid under pressure can have sufficient force to penetrate your skin causing serious injury and/or infection. Relieve pressure in the system before removing hoses, fittings, gauges, or components.

Unintended movement of the machine or mechanism may cause injury to the technician or bystanders.

To protect against unintended movement, secure the machine or disable / disconnect the mechanism while servicing.

ⓘ CAUTION

Contamination can damage internal components and void the manufacturer's warranty. Take precautions to ensure system cleanliness when removing and reinstalling system lines.

Note: Before performing adjustments, read page 14, *Pressure measurement*, for recommendations.

1. Install a pressure gauge in port M2 to measure system pressure. Install a pressure gauge in case drain port L1 or L2 to measure case pressure. ⚠ ⓘ
2. Start the prime mover and allow fluid to reach normal operating temperature. Operate a hydraulic function to its full extension, loading the pump at maximum pressure and zero flow.
3. Loosen the PC set screw and turn the PC adjustment screw until the desired setting is indicated on the pressure gauge at port M2 . Clockwise rotation will increase pressure, counterclockwise rotation will decrease; approximate gain = 35 bar [507 psi] per turn.

Note: If the pressure does not increase, an external system relief valve may require adjustment. External system relief valve must be set above the PC setting for proper operation.

4. While holding the position of the PC adjustment screw, torque the PC set screw to 7-11 N•m [6-8 lbf•ft].
5. Stop the prime mover, remove the pressure gauges, and return the system to its normal operating configuration.

PC control adjustment

Gauge port M2

	0-300 bar [0-5000 psi]		M14
	9/16-18		6mm
	1/4 in		27-35 N•m
	34-68 N•m [25-50 lbf•ft]		[20-26 lbf•ft]

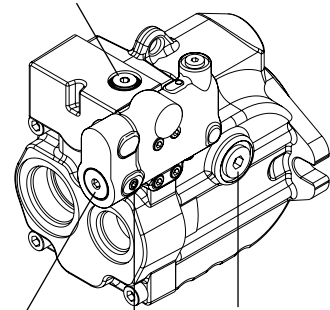

PC adjustment screw		Case drain port L1
	6mm	
PC set screw		0-10 bar [0-100 psi]
	4mm	
	7-11 N•m [6-8 lbf•ft]	
		7/8-14
		3/8 in
		54-136 N•m
		[40-100 lbf•ft]

P101 652E

Adjustment screw, set screw, and gauge locations shown

¹ PC setting is referenced to case pressure. Subtract case pressure from system pressure to compute the actual setting.

LS CONTROL

⚠ WARNING

Escaping hydraulic fluid under pressure can have sufficient force to penetrate your skin causing serious injury and/or infection. Relieve pressure in the system before removing hoses, fittings, gauges, or components.

Unintended movement of the machine or mechanism may cause injury to the technician or bystanders.

To protect against unintended movement, secure the machine or disable / disconnect the mechanism while servicing.

⚠ CAUTION

Contamination can damage internal components and void the manufacturer's warranty. Take precautions to ensure system cleanliness when removing and reinstalling system lines.

The LS setting is indicated in the pump model code. Refer to the *Series 45 Open Circuit Axial Piston Pumps Technical Information Manual*, BLN-10128, for more information.

Note: Before performing adjustments, read page 14, *Pressure measurement*, for recommendations.

1. Install a pressure gauge in port M2 to measure system pressure. Install a pressure gauge in drain port L1 or L2 to measure case pressure. Tee-in a gauge to the LS / remote PC signal line (port X). ⚠
2. Start the prime mover and allow fluid to reach normal operating temperature. Slowly operate a hydraulic function which will demand approximately half flow from the pump, but keep system pressure below the PC set point.
3. Loosen the LS set screw. While watching the pressure gauges, turn the LS adjustment screw until the desired pressure differential between port M2 and port X is achieved¹. Clockwise rotation will increase the setting, counterclockwise rotation will decrease; approximate gain = 12 bar [170 psi] per turn.

LS control adjustment

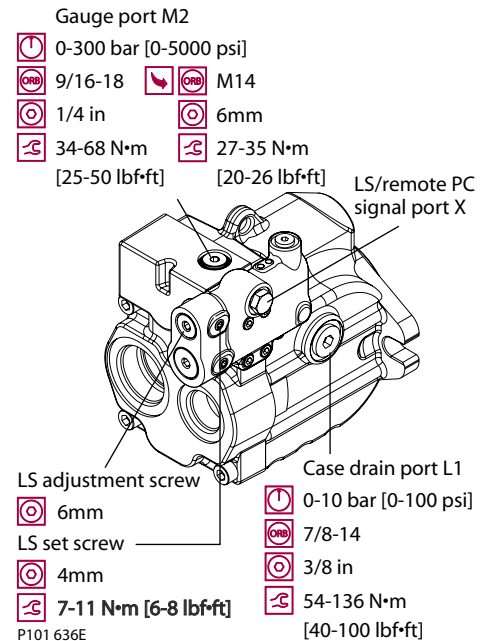

Adjustment screw, set screw, and gauge locations shown

4. While holding the position of the LS adjustment screw, torque the LS set screw to 7-11 N•m [6-8 lbf•ft].
5. Operate a hydraulic function to its full extension loading the pump at maximum pressure and zero flow.
6. Loosen the PC set screw and turn the PC adjustment screw until the desired setting is indicated on the pressure gauge at port M2². Clockwise rotation will increase pressure, counterclockwise rotation will decrease; approximate gain = 35 bar [507 psi] per turn.

Note: If the pressure does not increase, an external system relief valve may require adjustment. External system relief valve must be set above the PC setting for proper operation.

7. While holding the position of the PC adjustment screw, torque the PC set screw to 7-11 N•m [6-8 lbf•ft].
8. Stop the prime mover, remove the pressure gauges, and return the system to its normal operating configuration.

¹ The LS setting is a differential pressure. Subtract pilot pressure at port X from system pressure at port M2 to compute the actual setting.

² PC setting is referenced to case pressure. Subtract case pressure from system pressure to compute the actual setting.

**SHAFT SEAL
 REPLACEMENT**

A lip type shaft seal is used in the Series 45 open circuit variable pumps. This seal can be replaced without major disassembly of the unit. Replacement of the shaft seal requires removal of the pump from the machine.

Removal

1. Using the appropriate snap-ring pliers, remove the retaining ring (K010) from the housing.
2. Remove the shaft seal (K020) from the bore in the pump housing and discard. Avoid damaging the pump housing or shaft.

 Puncture the face of the seal with a packing hook, or use a slide-hammer type puller to remove the seal.

Shaft seal and retaining ring

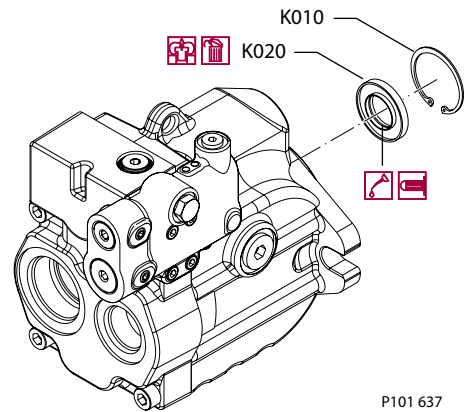

P101 637

Installation

3. Inspect the pump housing and new seal for damage. Inspect the sealing area on the shaft for rust, wear, or contamination. Polish the sealing area on the shaft if necessary.
4. Lubricate the lip of the new shaft seal with clean hydraulic fluid. Place a protective sleeve over the shaft end to prevent damage to the seal during installation.
5. Keeping the seal perpendicular to the shaft, press the new seal into the housing just far enough to clear the retaining ring groove.  Install seal with the cupped side toward the shaft bearing. Do not damage the seal during installation.
6. Using the appropriate snap ring pliers, install the seal retaining ring.
7. Remove the installation sleeve.

⚠ CAUTION

Premature bearing failure can result if the shaft seal contacts the shaft bearing. Press the seal into the housing only far enough to clear the retaining ring groove.

AUXILIARY PADS

Auxiliary mounting pads may be installed on pumps equipped with through-drive radial ported endcaps. Follow these steps to either remove, replace, or exchange auxiliary mounting pads.

Removal

1. Remove two screws (J130) retaining the cover plate (J110) or auxiliary pump (not shown). Remove the shipping cover or auxiliary pump and its sealing O-ring (J120). Discard the O-ring.
2. Remove the drive coupling (J140).
3. Remove the four screws (J100) retaining the pad adapter (J085) to the endcap. Discard the two pad adapter O-rings (J090, J095).

Auxiliary mounting pads

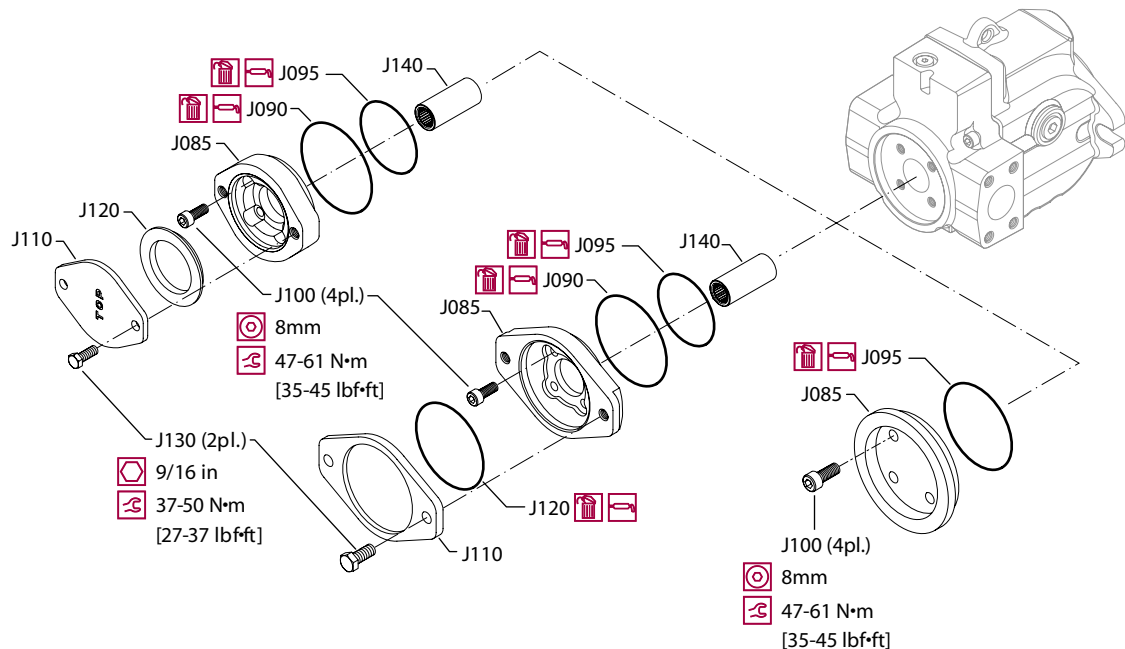

Installation

4. Lubricate new O-rings with petroleum jelly. Install the pad adapter to the endcap.
5. Install the four screws and torque to 47-61 N•m [35-45 lbf•ft].
5. Install the drive coupling.
6. Install shipping cover or auxiliary pump with new O-ring. 
7. Install two screws (J130) and torque to 37-50 N•m [27-37 lbf•ft].

⚠ CAUTION

Shipping cover is intended only to retain coupling during shipment and storage. Do not operate pump with coupling and shipping cover installed.

CONTROL

Disassembly

1. Remove the four screws (C300) holding the control housing onto the end cap.
2. Remove the control and discard the three interface O-rings (C200).
3. Remove the PC set screw (C102), PC adjustment screw (C138), O-ring (C136), springs (C135, C134), and seat (C133). Discard the O-ring.
4. Remove the plug (C103), O-ring (C103A), and PC spool (C132) from the control housing; discard the O-ring. Note orientation of the spool for reassembly.
5. Remove the plug (C107) and O-ring (C107A); discard the O-ring.

Note: For PC only controls, skip steps 6 and 7.

6. Remove the LS set screw (C102), LS adjustment screw (C118), O-ring (C116), back-up rings (C117), springs (C114, C115), and seat (C113); discard the O-ring.
7. Remove the plug (C106), O-ring (C106A), and LS spool (C112) from the control housing; discard the O-ring. Note orientation of the spool for reassembly.

Control assembly

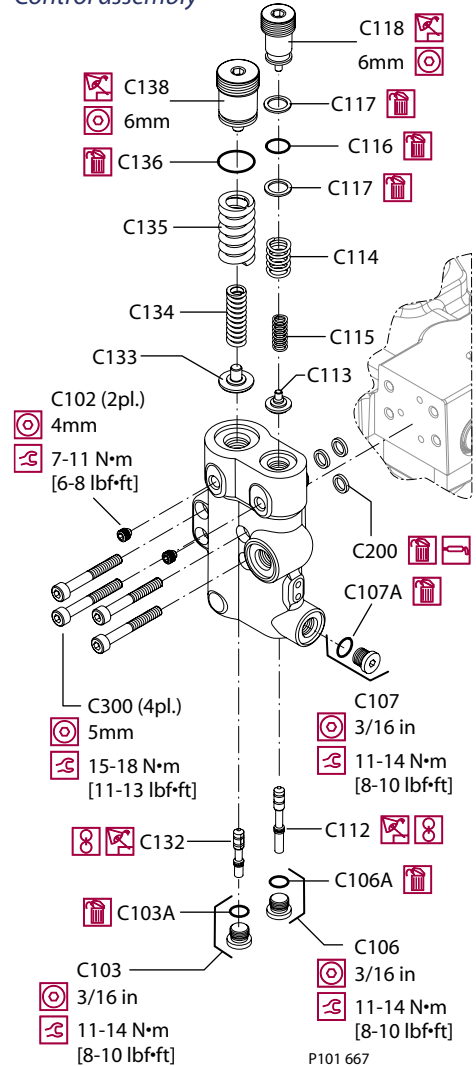

LS control shown; parts C106 and C112 through C118 are not used on PC control

Inspection

8. Inspect the adjustment screws for wear at the tips and where they contact the springs; replace as necessary
9. Inspect the springs and spring guides for wear or damage; replace as necessary.
10. Carefully inspect the spools. Ensure the sealing lands are free of nicks and scratches. Check the ends that contact the spring guides for wear. Replace spools as necessary.
11. Inspect the control housing for damage. Check the spool bores for excessive wear.
12. Clean all parts and lubricate spools, springs, guides and new O-rings with clean hydraulic fluid.

CONTROL
 (continued)

Reassembly

13. Install the PC spool, spherical end first, into the PC bore. The PC spool is the shorter of the two. Using a new O-ring, install the plug (C103). Torque to 11-14 N•m [8-10 lbf•ft].
14. Place the two PC springs onto the spring guide and install into the PC bore. Place a new O-ring onto the PC adjustment screw and thread it into the PC bore until flush, then make another full turn. Install and torque the set screw to 7-11 N•m [6-8 lbf•ft].

Note: For PC only controls, skip steps 15 and 16.

15. Install the LS spool, spherical end first, into the LS bore. The LS spool is the longer of the two. Using a new O-ring, install the plug (C106). Torque to 11-14 N•m [8-10 lbf•ft].
16. Place the two LS springs onto the spring guide and install into the LS bore. Place a new O-ring and back-up rings onto the LS adjustment screw and thread it into the LS bore until flush, then make another full turn. Install and torque the set screw to 7-11 N•m [6-8 lbf•ft].
17. Using a new O-ring, install the plug (C107). Torque to 11-14 N•m [8-10 lbf•ft].
18. Using petroleum jelly to retain them, install the three interface O-rings (C200) in the recesses on the control housing.

19. Install the control assembly onto the endcap using the four screws (C300). Torque to 15-18 N•m [11-13 lbf•ft]. Torque screws in a criss-cross pattern and re-torque the first screw to ensure proper torque retention.

20. Check and adjust the control setting. See *Adjustments*, page 20.

Control assembly

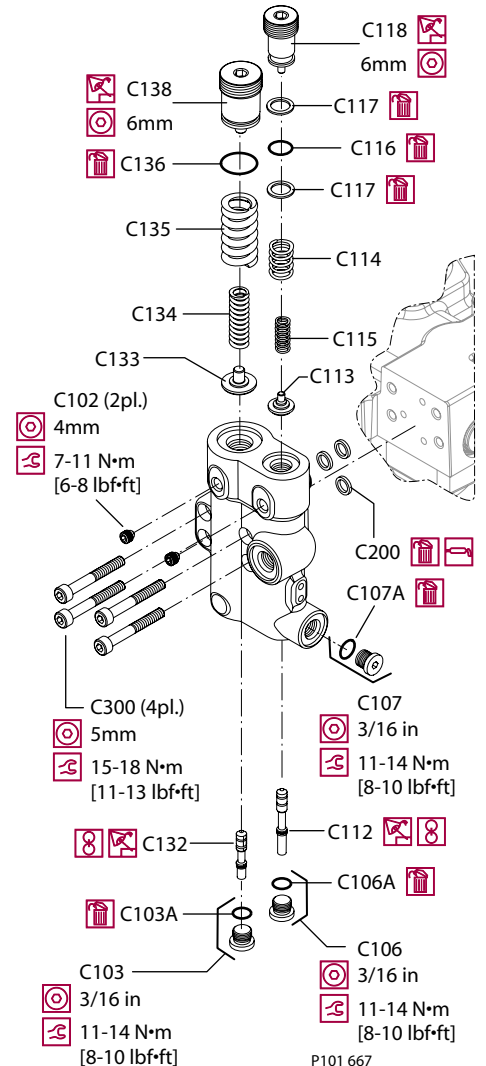

LS control shown; parts C106 and C112 through C118 are not used on PC control

PLUG AND FITTING SIZES AND TORQUES

If any plugs or fittings are removed from the unit during service, install and torque as indicated here. This drawing is a composite. Your configuration may differ but the appropriate wrench size and torque can be found here.

Plug locations, sizes, and torques

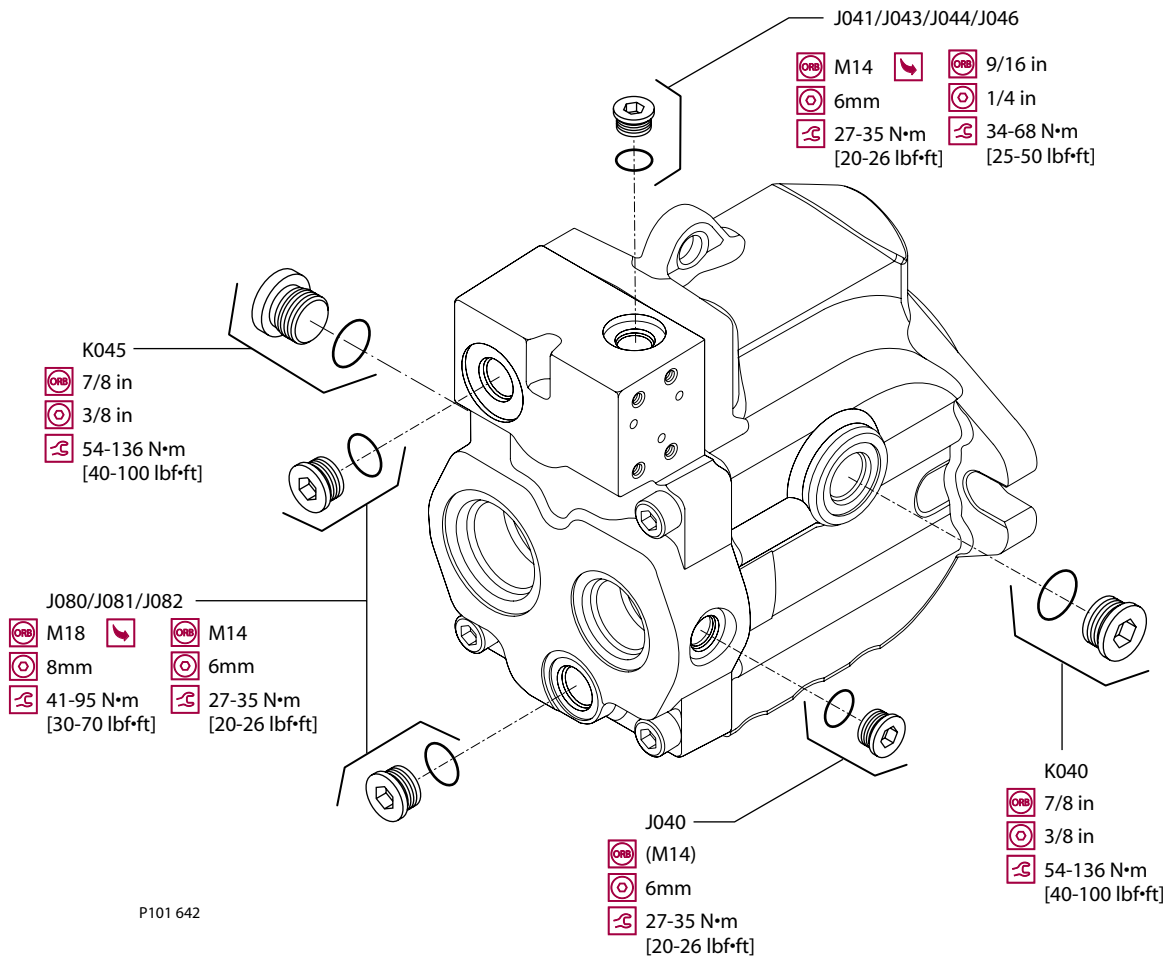

OUR PRODUCTS

Hydrostatic transmissions
Hydraulic power steering
Electric power steering
Closed and open circuit axial piston pumps and motors
Gear pumps and motors
Bent axis motors
Radial piston motors
Orbital motors
Transit mixer drives
Planetary compact gears
Proportional valves
Directional spool valves
Cartridge valves
Hydraulic integrated circuits
Hydrostatic transaxles
Integrated systems
Fan drive systems
Electrohydraulic controls
Digital electronics and software
Battery powered inverter
Sensors

Sauer-Danfoss Hydraulic Power Systems

– Market Leaders Worldwide

Sauer-Danfoss is a comprehensive supplier providing complete systems to the global mobile market.

Sauer-Danfoss serves markets such as agriculture, construction, road building, material handling, municipal, forestry, turf care, and many others.

We offer our customers optimum solutions for their needs and develop new products and systems in close cooperation and partnership with them.

Sauer-Danfoss specializes in integrating a full range of system components to provide vehicle designers with the most advanced total system design.

Sauer-Danfoss provides comprehensive worldwide service for its products through an extensive network of Authorized Service Centers strategically located in all parts of the world.

Sauer-Danfoss (US) Company
2800 East 13th Street
Ames, IA 50010, USA
Phone: +1 515 239-6000, Fax: +1 515 239 6618

Sauer-Danfoss (Neumünster) GmbH & Co. OHG
Postfach 2460, D-24531 Neumünster
Krokamp 35, D-24539 Neumünster, Germany
Phone: +49 4321 871-0, Fax: +49 4321 871 122

Sauer-Danfoss (Nordborg) A/S
DK-6430 Nordborg, Denmark
Phone: +45 7488 4444, Fax: +45 7488 4400



DH, DS Series 0 and 1 Motors

Service Instructions

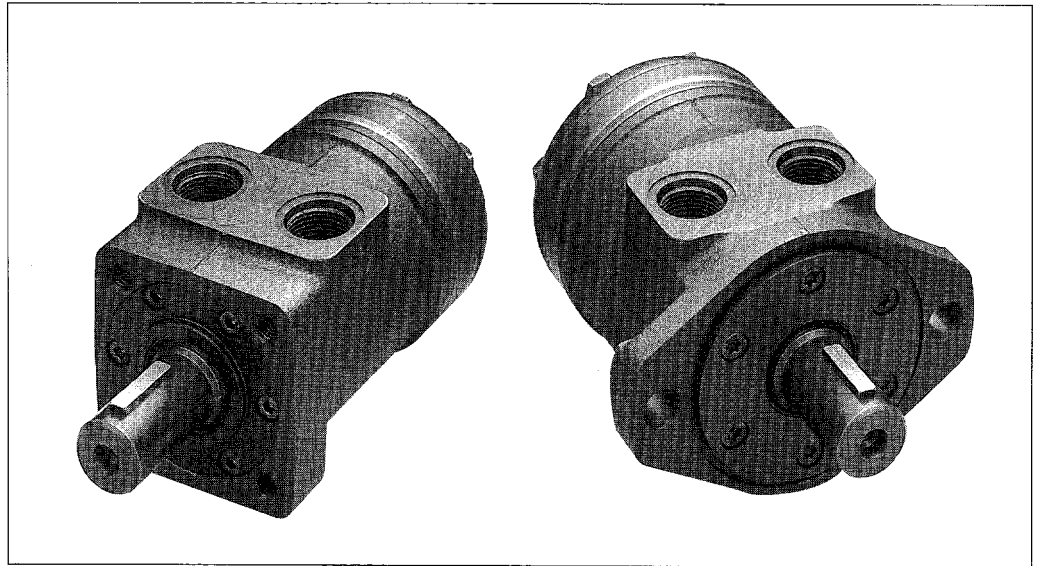

Series 0 has removable spigot flange.

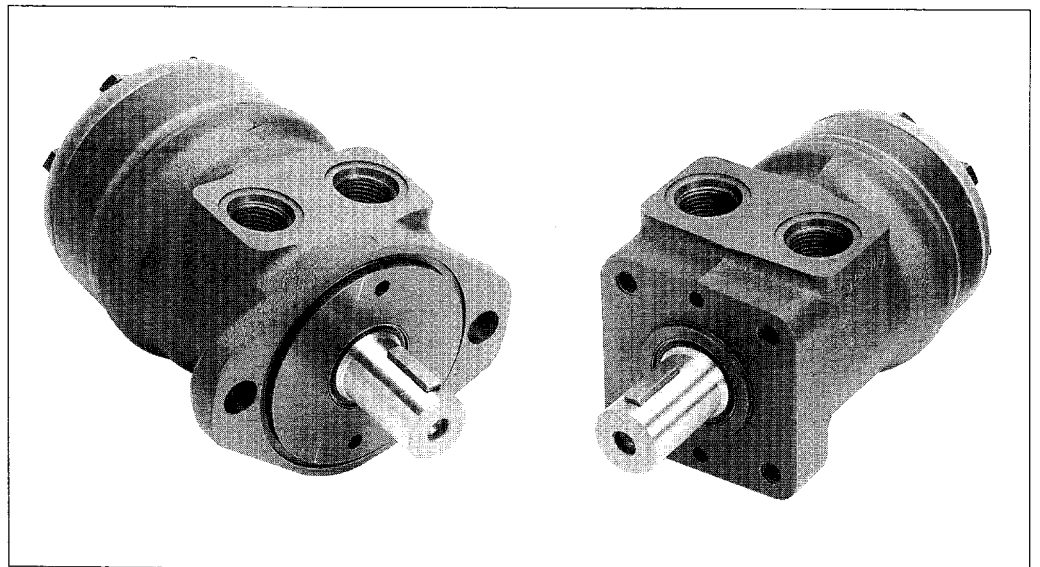

Series 1 is the latest model with common body and mount.

Cost-free Repairs

Cost-free repairs, mentioned in the Danfoss General Conditions of Sale, are carried out only at Danfoss, Nordborg or at service shops authorized by Danfoss.

Special Tools:

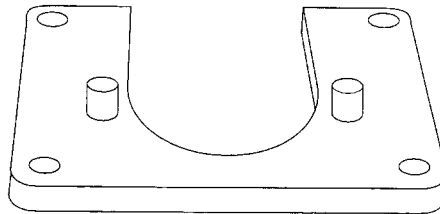

Main holding tool (horseshoe):
Code No.: SJ 151-9000-1.

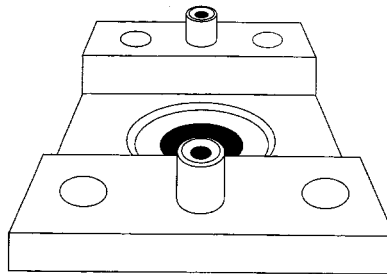

Holding tool for bushing:
Code No.: SJ 151-9000-2

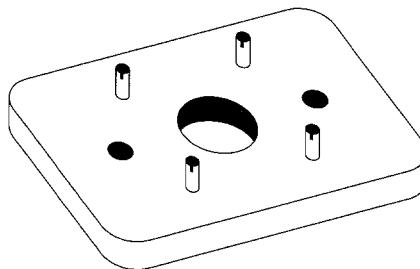

Holding tool for motor with square
mounting flange.
Code No.: SJ 151-9000-12

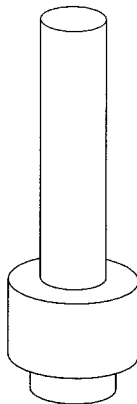

Seal plunger:
Code No.: SJ 151-0414-01

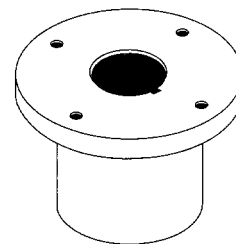

Bushing for 1-inch shaft:
Code No.: SJ 151-9000-11

Dismantling

Item	Part to Remove	Comments
8	Woodruff key	On cylindrical shafts.
		Put the motor in a holding tool, with the output shaft down.
[19]	[Drain plug]	[A/flats: 9/16 inch.]
15, 16	Screws, washers – 6 pcs. ea.	Use a 13 mm socket.
14	End cover	Remove end cover sideways.
13	Gear wheel set O-rings – 2 pcs.	Keep fingers under the gearwheel set to prevent the parts from falling out.
10	Cardan shaft	
11, 12	Distributor plate O-ring	
9	Output shaft	
[1]	[Screws – 6 pcs]	[Use Torx type T30 or 4 mm hexagon Unbrako wrench.]
[3]	[Spigot flange]	
[5, 6]	[O-ring bearing race]	[Use a .08 inch (2 mm) screwdriver.]
20	Check valves – 2 pcs.	DS ONLY Pull the check valve out with, for example, a ground (shortened) 1/4-inch or 3,5 mm screw tap.
4	Shaft seal	Knock out the shaft seal with a plastic hammer and .16 inch (4 mm) screwdriver.
2	Dust seal	Use a .16 inch (4 mm) screwdriver.
7	Axial Load Bearing & Bearing Race	

[where applicable]

Cleaning

Clean all parts carefully with low aromatic kerosene.

Inspection and Replacement

Check all parts carefully and replace if necessary.

Lubrication

Before assembly, lubricate all parts with hydraulic oil and grease rubber parts with vaseline.

Assembly

Item	Part to Mount	Comments
[20]	[Check valves]	[Place the motor housing in a holding tool with the flange uppermost.] [DS ONLY] Grease the check valves (fitted with new O-rings) and fit them in their bores with light blows, using a plastic hammer.]
4	Shaft seal	Grease the seal with hydraulic oil Use tool SJ 151-0414-01 to press the seal into the recess. [Place the seal into position. Check that the seal lies against the cover recess.]
2	Dust seal	Place the dust seal ring in the spigot, and knock it into place with a plastic hammer and appropriate mandrel.
7	Axial load bearing	Place needle bearing and bearing race on the output shaft.
[6]	[Bearing race]	[Grease the O-ring with vaseline, and fit the bearing race and the O-ring into the spigot flange.]
[3]	[Spigot flange]	[Turn, so that the holes line up.]
[1]	[Screws – 6 off]	[Tightening torque: Hexagon socket screws M5 45–70 lbf in (0,5– 1,0 daNm); Torx screws M6 45 – 70 lbf in (0,5 – 0,8 daNm) After this, turn the motor over.]
9	Output shaft	Grease the journals with hydraulic oil.
8	Woodruff key	In the cylindrical shaft.
11	O-ring	Grease the O-ring, and put it in the O-ring groove of the housing.
12	Distributor plate	Turn the distributor plate, so that the holes line up.
10	Cardan shaft	Guide the cardan shaft down into the motor housing.

[where applicable]

Assembly

Item	Part to Mount	Comments
13, 11	Gearwheel set	<p>Place the O-rings (greased) in the O-ring (see Figure A) grooves of the gearwheel.</p> <p>In gearwheels with non-through splines, place the gearwheel with the recess in the spline hole facing down towards the housing.</p> <p>Place the gearwheel set on the cardan shaft, so that the top of the teeth in the external teeth of the gearwheel are vertically above the slot in the output shaft (cylindrical) or the top of a tooth on a splined shaft.</p> <p>Turn the gearwheel set counterclockwise until the cardan shaft and the gearwheel start to mesh (15°).</p> <p>Turn the gearwheel rim, so that the holes made for the screws line up.</p>
14	End cover	Turn the end cover, so that holes line up.
15, 16	Washer, screws (6 off)	Use a 13 mm socket. Tightening torque: 265 – 310 lbf in (3,0 – 3,5 daNm).
[19]	[Drain plug]	[Use a 9/16 inch socket. Tightening torque: 90 – 100 in-lbs (1 – 2 daNm)]
8	Woodruff key	To be secured with tape or plastic ring.

[where applicable]

Figure A

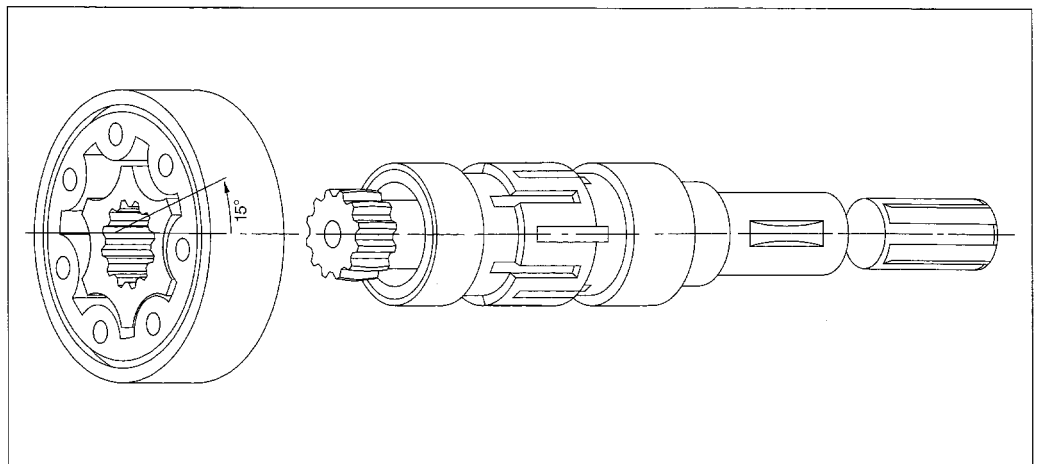

DH/DS				
Item	Spare Parts	Series 0 and Series 1 with separate Spigot Flange	Series 1 with Integrated Spigot Flange	Number per Motor
[1]	Screw M6, L = .79 inch (20 mm) (two-hole mounting flange)	[681x1989]	—	[6]
[1a]	Screw M5, L = .63" (16 mm) (four-hole mounting flange)	[681x1961]	—	[6]
2	Dust seal ring 1.38" x 1.08" x .16" (35 x 27,8 x 4 mm) — Series 0 1.38" x 1.13" x .09" (35 x 28,6 x 2,2 mm) — Series 1	151-1313	633B0370	1
[3]	[Spigot flange (two-hole mounting flange)]	[151-2640]	—	[1]
[3a]	[Spigot flange for HPS (two-hole mounting flange)]	[151-2674]	—	[1]
3b	Spigot flange (four-hole mounting flange)	151-1827	—	1
3c	Spigot flange for HPS (four-hole mounting flange)	151-5606	—	1
4	Shaft seal 1.65" x 1.12" x .22" (42,0 x 28,6 x 5,5 mm) NBR	633B3385	—	1
4a	HPS (High Pressure Shaft Seal) 1.54" x 1.13" x .19" (39 x 28,6 x 4,9 mm) — Series 1	633B0414	633B0414	1
[5]	[O-ring 1.87" x .14" (47,6 x 3,5 mm) NBR (two-hole mounting flange)]	[633B1191]	—	[1]
[5a]	[O-ring 1.91" x .08" (48,0 x 2,0 mm) NBR (four-hole mounting flange)]	[633B1333]	—	[1]
6	Bearing race 1.87" x 1.16" x .12" (47,5 x 29,5 x 3 mm) — Series 0 1.64" x 1.14" x .16" (41,6 x 29 x 4 mm) — Series 1	151-1608	151-5708	1
7	Axial needle bearing 1.77" x 1.13" x .12" (45 x 28,6 x 3 mm) — Series 0 1.59" x 1.19" x .18" (40,3 x 30,3 x 4,5 mm) — Series 1	151-1458	151-5709	1
8	Woodruff key	682L9054	682L9054	1
9	Housing and output shaft	not sold separately		

[where applicable]

DH Spare Parts

DH Only												
Item	Spare Parts				Series 0 and Series 1 with Separate Spigot Flange	Series 1 with Integrated Spigot Flange	Number per Motor					
10	Cardan shaft – in. (mm)											
		Length		Diameter								
	DH 36	3.01	(76,6)	.73	(18,6)	151-2642	151-2643	1				
	DH 50	3.02	(76,8)	.71	(18)	151-2643	151-2643	1				
	DH 80	3.17	(80,7)	.71	(18)	151-2644	151-2644	1				
	DH 100	3.28	(83,3)	.71	(18)	151-2645	151-2645	1				
	DH 125	3.43	(87,1)	.71	(18)	151-2646	151-2646	1				
	DH 160	3.59	(91,2)	.71	(18)	151-2647	151-2647	1				
	DH 200	3.79	(96,4)	.79	(20)	151-2648	151-2648	1				
	DH 250	4.05	(102,9)	.79	(20)	151-2649	151-2649	1				
DH 315	4.38	(111,4)	.79	(20)	151-2650	151-2650	1					
DH 400	4.82	(122,6)	.79	(20)	151-2651	151-2651	1					
11	O-ring	3.0" x .07" (75,9 x 1,8 mm)		NBR		633B1173	633B1173	3				
12	Distributor plate				151-1713	151-1713	1					
13	Gear wheel set – in. (mm)											
		Width										
	DH 36	.23	(5,9)		151-1258	151-1258	1					
	DH 50	.25	(6,5)		151-1126	151-1126	1					
	DH 80	.41	(10,4)		151-1127	151-1127	1					
	DH 100	.51	(13,0)		151-1128	151-1128	1					
	DH 125	.64	(16,3)		151-1112	151-1112	1					
	DH 160	.81	(20,8)		151-1129	151-1129	1					
	DH 200	1.02	(26,0)		151-1185	151-1185	1					
	DH 250	1.28	(32,5)		151-1193	151-1193	1					
DH 315	1.61	(40,9)		151-1186	151-1186	1						
DH 400	2.04	(52,0)		151-1187	151-1187	1						
14	End cover	7/16-20 UNF thread			151-2641	151-2673	1					
15	Washer				684 x 2481	684 x 0076	6					
DS Only												
10	Cardan shaft – in. (mm)											
		Series 0 Length		Series 0 Diameter								
		Series 1 Length		Series 1 Diameter								
	DS 50	3.14	(79,7)	.79	(20)	3.14	(79,7)	.79	(20)	151-2652	151-2652	1
	DS 80	3.32	(84,4)	.79	(20)	3.32	(84,4)	.79	(20)	151-2653	151-2653	1
	DS 100	3.45	(87,8)	.79	(20)	3.45	(87,8)	.79	(20)	151-2654	151-2653	1
	DS 125	3.63	(92,2)	.79	(20)	3.48	(88,3)	.79	(20)	151-2655	151-2694	1
	DS 160	3.87	(98,3)	.79	(20)	3.65	(92,7)	.79	(20)	151-2656	151-2695	1
	DS 200	4.14	(105,3)	.87	(22)	3.89	(98,8)	.79	(20)	151-2657	151-2696	1
	DS 250	4.49	(114,0)	.87	(22)	4.17	(105,8)	.79	(21)	151-2658	151-2697	1
DS 315	4.93	(125,4)	.87	(22)	4.51	(114,5)	.87	(22)	151-2659	151-2698	1	
DS 375	5.33	(135,6)	.87	(22)	5.11	(129,9)	.87	(22)	151-2660	151-2699	1	

[where applicable]

DS Spare Parts

DS ONLY					
Item	Spare Parts	Series 0 and Series 1 with Separate Spigot Flange	Series 1 with Integrated Spigot Flange	Number per Motor	
11	O-ring 3.5" x .08" (90 x 2,0 mm) NBR	633B1301	633B1301	3	
12	Distributor plate	151-1702	151-1702	1	
13	Gear wheel set – in. (mm)				
	Width Series 0	Width Series 1			
	DS 50 .35 (9,0)	.35 (9,0)	151-1182	151-1182	1
	DS 80 .55 (14,0)	.55 (14,0)	151-1138	151-1138	1
	DS 100 .69 (17,6)	.55 (14,0)	151-1139	151H2102	1
	DS 125 .85 (21,7)	.69 (17,6)	151-1140	151H2103	1
	DS 160 1.09 (27,8)	.85 (21,7)	151-1141	151H2104	1
	DS 200 1.37 (34,8)	1.09 (27,8)	151-1189	151H2105	1
	DS 250 1.71 (43,5)	1.37 (34,8)	151-1190	151H2106	1
	DS 315 2.16 (54,8)	1.71 (43,5)	151-1191	151H2107	1
	DS 375 2.55 (65,0)	2.16 (54,8)	151-1192	151H2108	1
14	End cover 7/16-20 UNF thread	151-1731	151-5568	1	
15	Washer	684 x 2481	684 x 0076	6	
DH ONLY					
16	Screw M8 x 1,25 mm Din 931 – in. (mm) Length				
	DH 36 1.40 (35)	681 x 0179	681 x 0179	6	
	DH 50 1.40 (35)	681 x 0179	681 x 0179	6	
	DH 80 1.60 (40)	681 x 0180	681 x 0180	6	
	DH 100 1.60 (40)	681 x 0180	681 x 0180	6	
	DH 125 1.80 (45)	681 x 0181	681 x 0181	6	
	DH 160 2.00 (50)	681 x 0182	681 x 0182	6	
	DH 200 2.20 (55)	681 x 0183	681 x 0183	6	
	DH 250 2.40 (60)	681 x 0184	681 x 0184	6	
	DH 315 2.80 (70)	681 x 0186	681 x 0186	6	
	DH 400 3.10 (80)	681 x 0188	681 x 0188	6	
[17]	[Name plate]	151A0411	150A6006	[1]	
[19]	[Drain plug 7/16-20 UNF thread]	151-5439	—	[1]	
21	Set of seals	151-1273	—	1	
21a	Set of seals HPS	151-1281	151-1286	1	
22	Port Plug	633 x 0017	633 x 0017	2	

[where applicable]

Part Number Identification

DS ONLY				
Item	Spare Parts	Series 0 and Series 1 with Separate Spigot Flange	Series 1 with Integrated Spigot Flange	Number per Motor
16	Screw M8 x 1,25 mm Din 931 – in. (mm) Length DS 50 1.57 (40) DS 80 1.77 (45) DS 100 1.77 (45) DS 125 1.96 (50) DS 160 2.16 (55) DS 200 2.55 (65) DS 250 2.95 (75) DS 315 3.34 (85) DS 375 3.74 (95)	681 x 0180 681 x 0181 681 x 0181 681 x 0182 681 x 0183 681 x 0185 681 x 0187 681 x 0189 681 x 0190	681 x 0180 681 x 0181 681 x 0181 681 x 0181 681 x 0182 681 x 0183 681 x 0185 681 x 0187 681 x 0189	7 7 7 7 7 7 7 7 7
[17]	[Name plate]	151A0411	150A6006	[1]
[19]	[Drain plug 7/16-20 UNF thread]	151-5439	—	[1]
21	Set of seals	151-1274	—	1
21a	Set of seals HPS	151-1282	151-1286	1
22	Port Plug	633 x 0017	633 x 0017	2

[where applicable]

Part Number Identification

DH Series 0 & Series 1 with Separate Spigot Flange

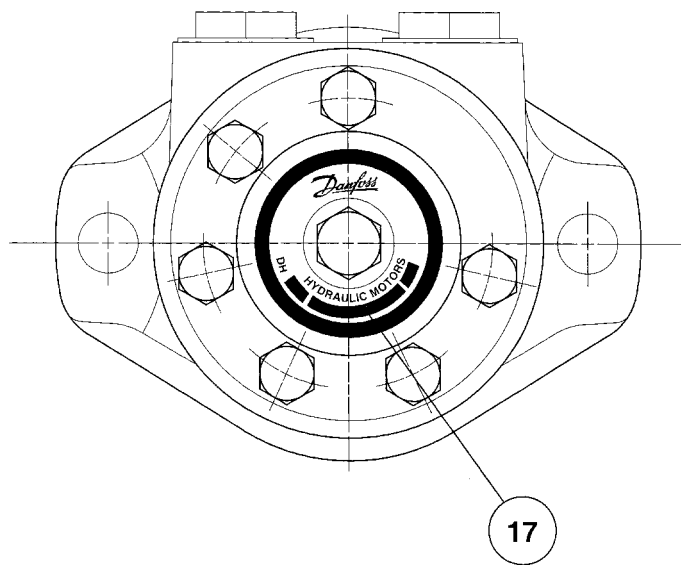
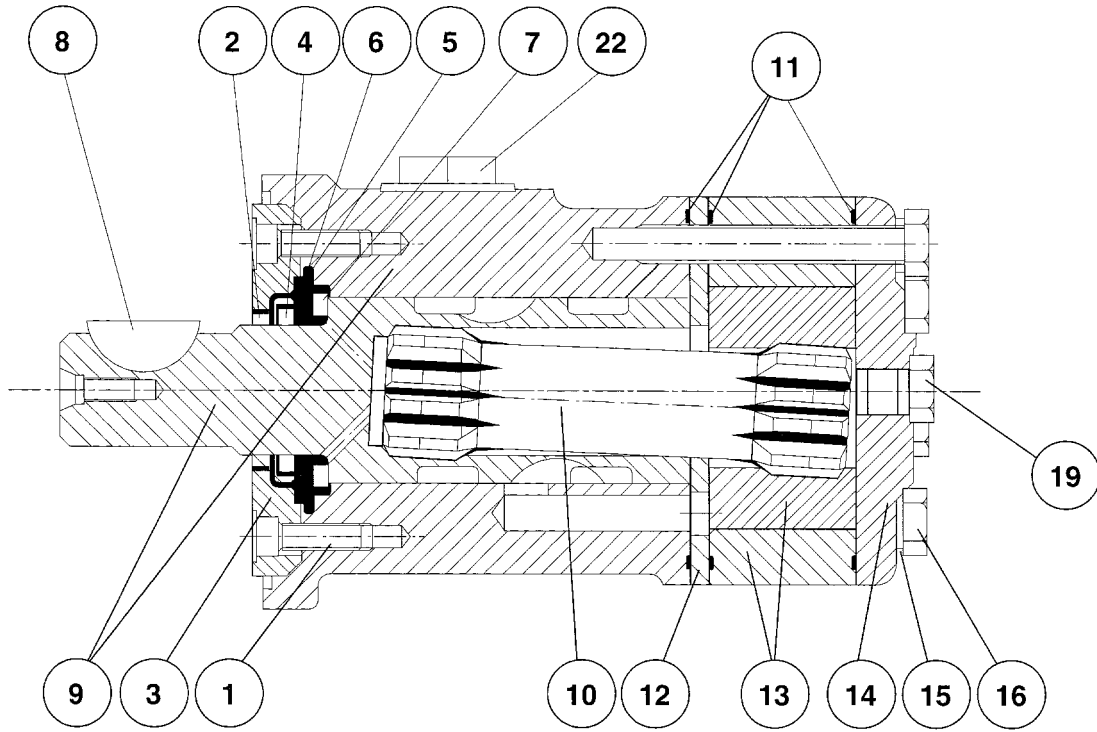

Part Number Identification

DS Series 0 & Series 1 with Separate Spigot Flange

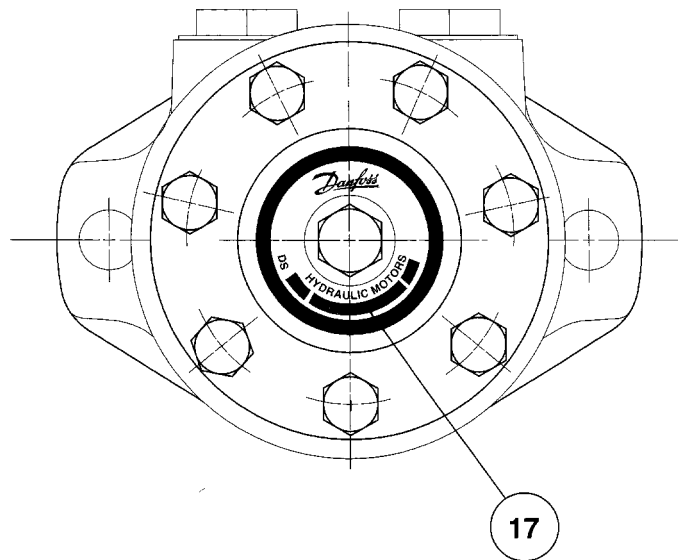
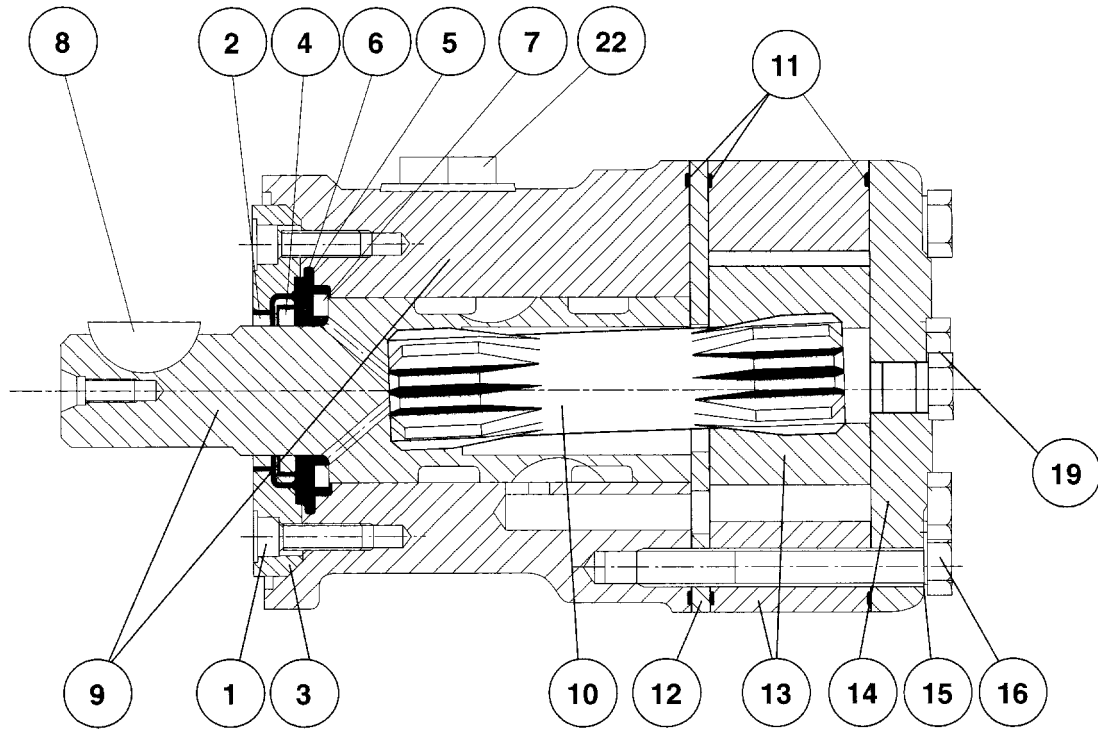

Part Number Identification

DH Series 1 with Integrated Spigot Flange

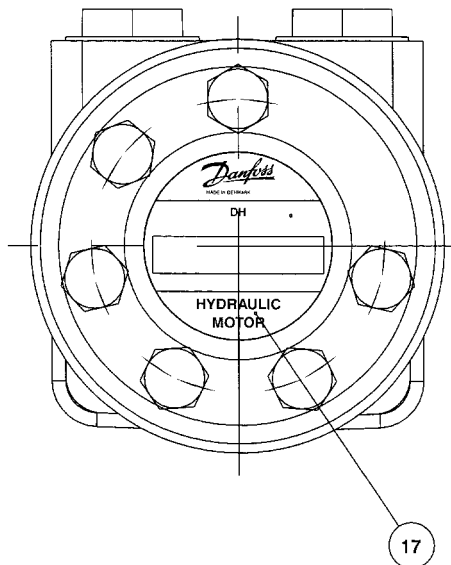
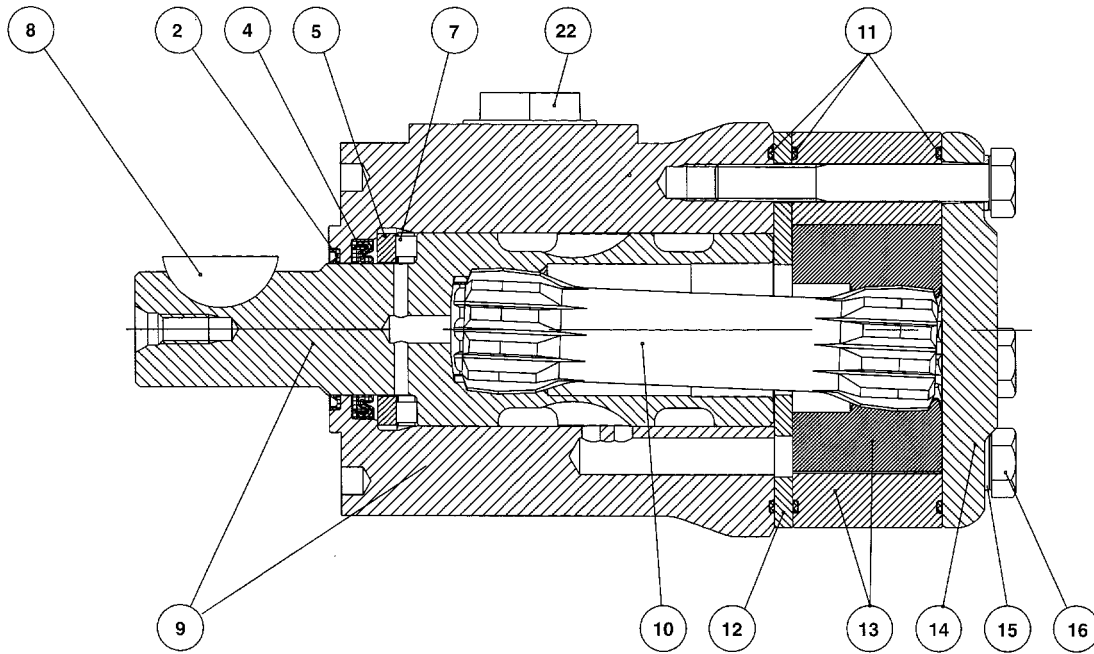

Part Number Identification

DS Series 1 with Integrated Spigot Flange

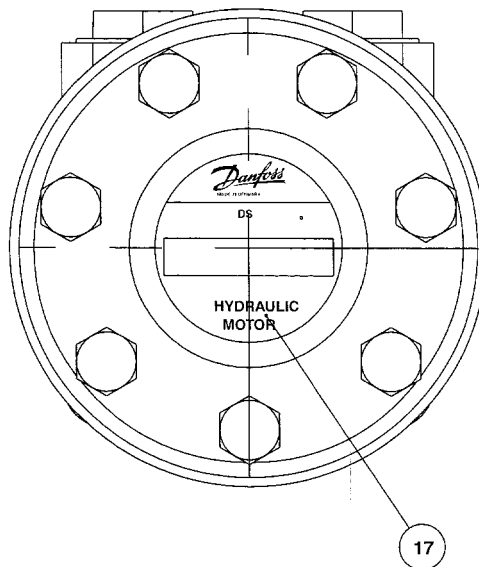
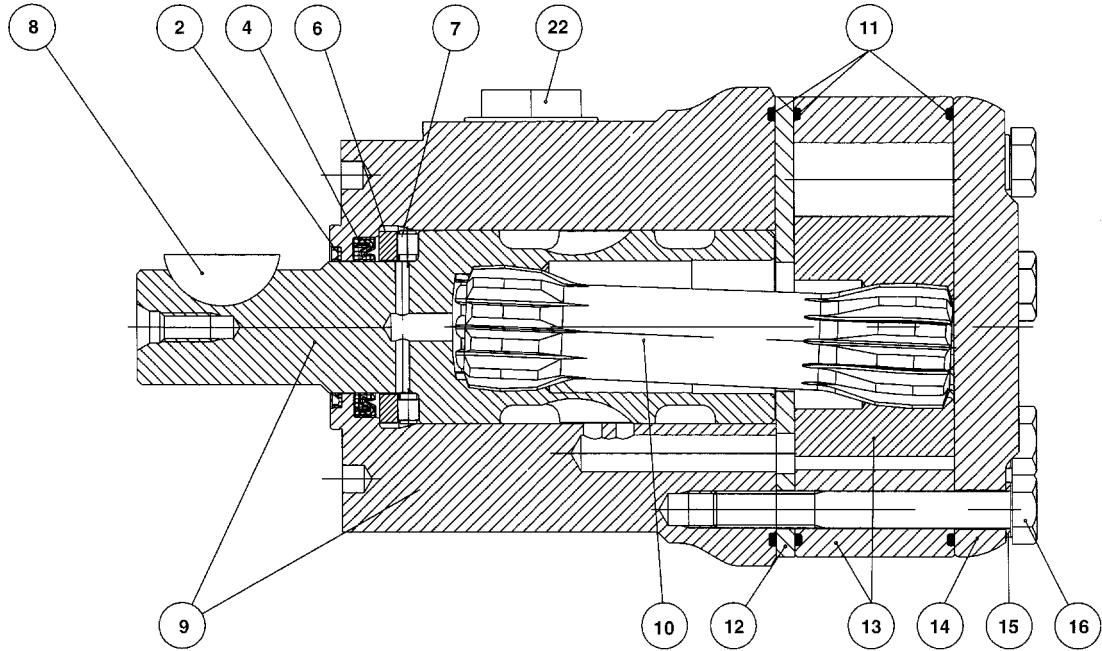

Danfoss

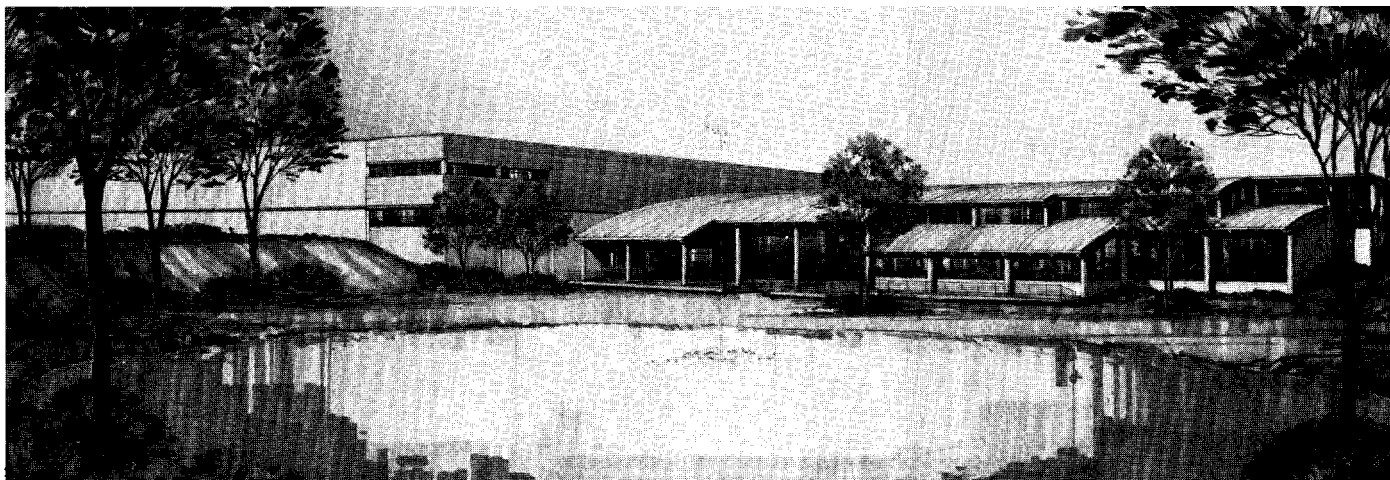

Danfoss can accept no responsibility for possible errors in catalogues, brochures and other printed material. Danfoss reserves the right to alter its products without notice. This also applies to products already on order provided that such alterations can be made without subsequential changes being necessary in specifications already agreed. All trademarks in this material are property of the respective companies. Danfoss and the Danfoss logotype are trademarks of Danfoss A/S. All rights reserved.

Danfoss

Danfoss Fluid Power
a division of Danfoss Inc.

North American Headquarters
8635 Washington Avenue
Racine, Wisconsin 53406-3773
Phone: (414) 884-7400
Fax: (414) 884-7440

Canadian Branch Office
7880 Tranmere Drive
Mississauga, Ontario
Canada L5S 1L9
Phone: (905) 673-0559
Fax: (905) 673-5039

World Headquarters
Danfoss A/S
DK-6430 Nordborg
Denmark
Phone: + 45 74 88 22 22
Fax: + 45 74 49 09 49

Hydraulic motor OMH SAE-version

DKMH.PS.180.A1.22

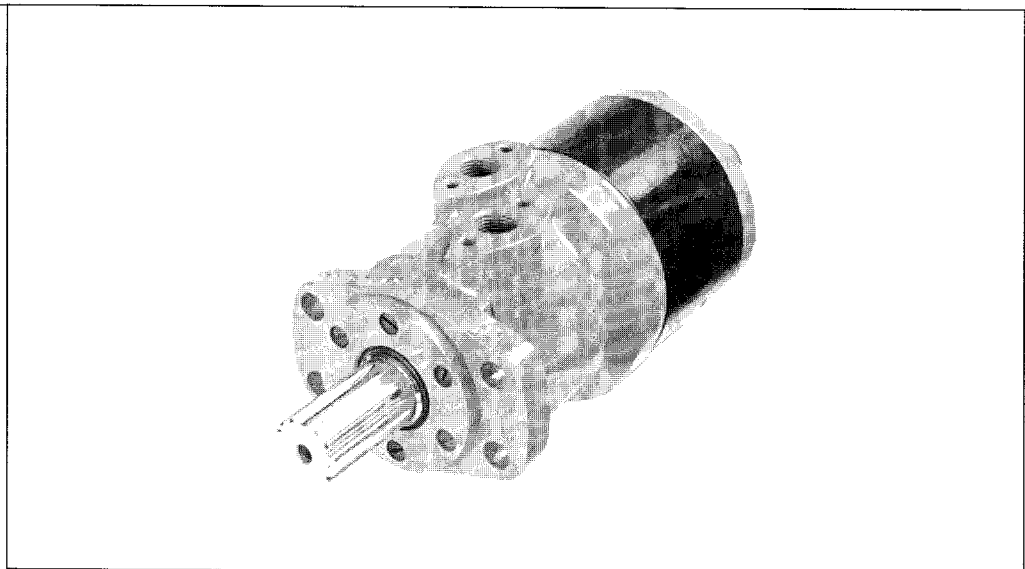

Index

	Page
Authorized service-shops.....	2
Exploded view OMH.....	3
Spare part list.....	4
Tools.....	4
Dismantling	5
Assembly	8
Hydraulics Organisation.....	13

Vederlagsfri reparation	Vi gør opmærksom på, at vederlagsfri reparation som omtalt i Danfoss' Almindelige Leveringsbetingelser kun udføres hos Danfoss Nordborg eller hos Danfoss autoriserede service shops.
Cost-free repairs	Please note that as mentioned in Danfoss General Conditions of Sale, cost-free repairs are carried out only at Danfoss Nordborg or in service shops authorized by Danfoss.
Kostenlose Reparatur	Beachten Sie bitte, daß die in den "Allgemeinen Lieferbedingungen" von Danfoss erwähnte kostenlose Reparatur nur bei Danfoss Nordborg oder bei den von Danfoss autorisierten Kundendienstwerkstätten ausgeführt wird.
Réparation gratuite	Nous faisons observer que la réparation gratuite mentionnée dans les Conditions générales de Vente de Danfoss ne devra être effectuée que dans les ateliers Danfoss à Nordborg ou dans les ateliers de dépannage agréés par Danfoss.

Specialudførelse	Reservedelslisten kan ikke anvendes til bestilling af reservedele til OMH i specialudførelser. Kontakt venligst Danfoss vedrørende dette spørgsmål.
Special version	The list of spare parts cannot be used when ordering parts for special OMH versions. In this respect, please contact Danfoss.
Sonderausführung	Die Ersatzteilliste kann nicht für Bestellung von Ersatzteilen für OMH in Sonderausführungen benutzt werden. Wenden Sie sich diesbezüglich bitte an Danfoss.
Version spéciale	LA liste de pièces de rechange ne peut pas être utilisée pour commander pièces de rechange pour OMH en version spéciales. A ce sujet, veuillez contacter Danfoss.

Authorized Service-Shops	Australia	: Danfoss (Australia) Pty. Ltd., Melbourne
	Austria	: Hainzl Industriesysteme, Gesellschaft m.b.H, Linz
	Belgium	: N.V. Danfoss S.A., Bruxelles
	Brazil	: Danfoss do Brasil Ind.e Com. Ltda., São Paulo
	Canada	: Danfoss Mfg. Co. Ltd., Mississauga
	Denmark	: Danfoss Hydraulik A/S, Stenløse
	Finland	: OY Danfoss AB, Espoo
	France	: Danfoss S.a.r.l., Trappes (Paris)
	Germany	: Danfoss GmbH, Offenbach/Main
	Great Britain	: Danfoss Limited, Greenford (London)
	Iceland	: HEDINN VERSLUN H/F, Reykjavik
	India	: DANTAL HYDRAULICS PVT Ltd., New Delhi
	Italy	: Danfoss s.r.l. Division Sordella, Torino
	Japan	: Danfoss K.K., Gotemba
	Korea	: UNITEK Corporation, Seoul
	Netherlands	: ITHO B.V., Schiedam
	New Zealand	: Danfoss (New Zealand) Limited, Auckland
	Norway	: Danfoss A/S, Skui
	Republic of South Africa	: Danfoss (Pty) Ltd., Johannesburg
	Singapore	: Danfoss Industries Pte. Ltd., Singapore
	Spain	: Danfoss S.A., San Sebastian de los Reyes, (Madrid)
	Sweden	: Danfoss AB, Mjölby
	Switzerland	: Danfoss Werner Kuster AG, Frenkendorf
	Turkey	: Mert Teknik A.S., Istanbul
	U.S.A.	: Danfoss Fluid Power Div. Racine, Wisconsin

Service-Shops	Australia	: Danfoss (Australia) Pty. Ltd., Adelaide
	Australia	: Danfoss (Australia) Pty. Ltd., Brisbane
	Australia	: Danfoss (Australia) Pty. Ltd., Perth
	Australia	: Danfoss (Australia) Pty. Ltd., Sydney
	Czech Rep.	: TECHNO TRADE, Olomouc
	Greece	: A. SKOURA & Co. E.E., Athens
	New Zealand	: Danfoss (New Zealand) Limited, Christchurch
	Portugal	: Danfoss (Portugal), da., Carnaxide
	Taiwan	: SYMBRIDGE Machinery Co. Ltd., Taipei

Exploded view OMH

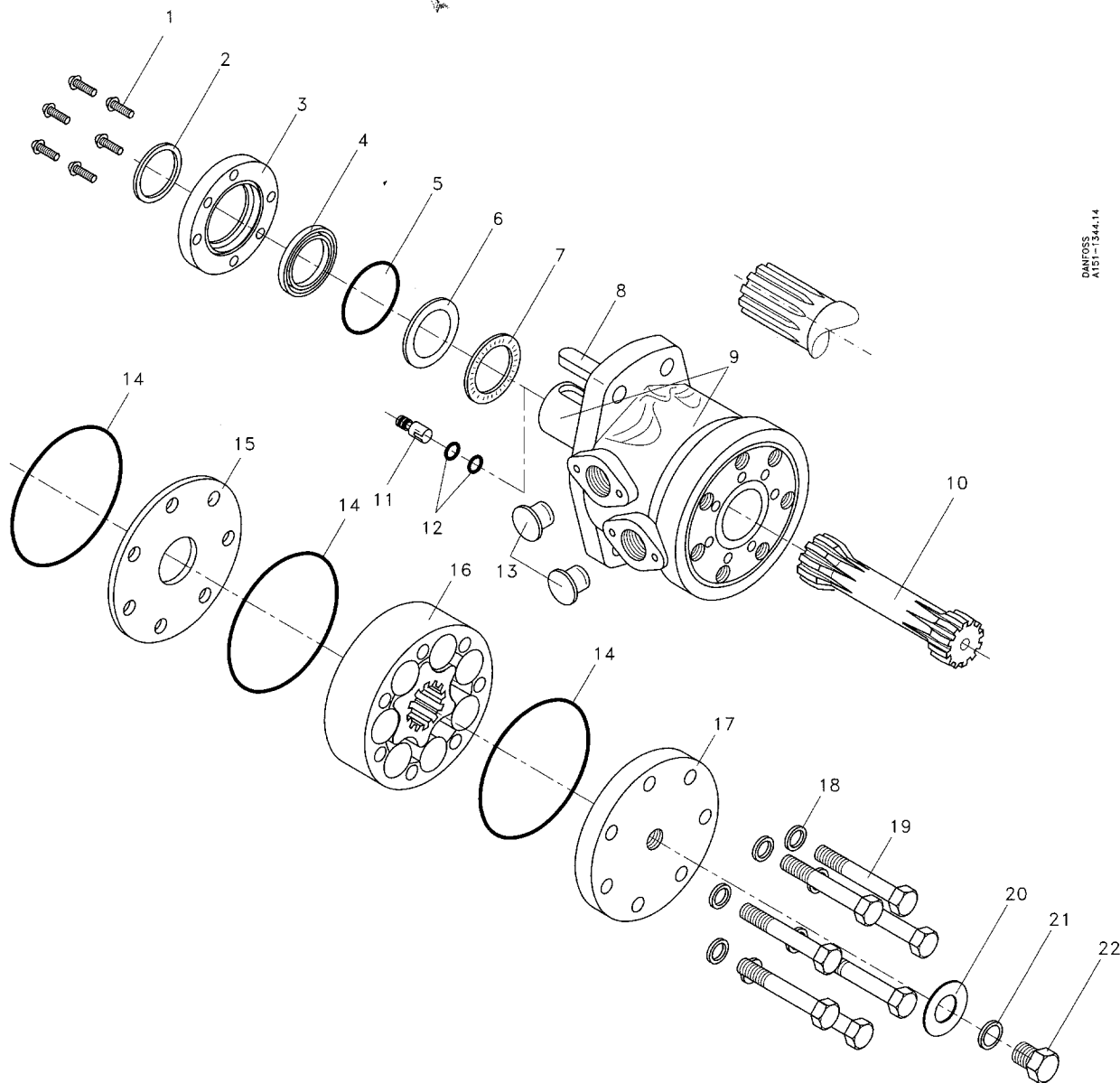

DANFOSS
A151-1344-14

Tightening torque		
Item	daNm	in-lbs
1	.5 - .8	45 - 70
19	5.2 - 5.7	460 - 500
22	3.0 - 6.0	265 - 530

Spare part

Item	Spare part	Stock per 1000 motors**		
		Number per motor		
		Code number		
1	Screw M6; 1 = 16 mm, Torx T30	681X1989	6	105
2	Dust seal ring ø1 ¹ / ₄ in, 1 ¹ / ₄ in spl. shaft 36 x 42 x 3.5 1 in SAE 6B sline shaft 28.5 x 35 x 4	633B3396	1	*
		151-1313	1	*
3	Spigot flange ø1 ¹ / ₄ in, 1 ¹ / ₄ in spl. shaft 36 x 42 x 3.5 1 in SAE 6B sline shaft 28.5 x 35 x 4	151H0301	1	10
		151H0386	1	10
4	Shaft seal ø1 ¹ / ₄ in, 1 ¹ / ₄ in spl. shaft 36 x 48 x 5.5 1 in SAE 6B sline shaft 28.56 x 42 x 5.5	633B3395	1	*
		633B3385	1	*
5	O - ring 53 x 2 mm	633B1528	1	*
6	Bearing race 37 x 52 x 3.5 mm	981X9224	1	15
7	Axial needle bearing 36 x 52 x 3 mm	981X9223	1	15
8	Parallel key ø32 and ø35 mm shaft	151-4109	1	15
9	Housing and output shaft	Not sold separately		
10	Cardan shaft OMH 200 OMH 250 OMH 315 OMH 400 OMH 500	151H0338	1	10
		151H0339	1	10
		151H0340	1	10
		151H0341	1	10
		151H0342	1	10
11	Check valve (incl. item 12)	151-1076	2	30
12	O-ring 5 x 1.5 mm	633B1324	4	60
13	Seal plug	633X0017	2	100
14	O-ring 105 x 2 mm	633B1807	3	*
15	Distributor plate	151H0305	1	10
16	Gearwheel set OMH 200 OMH 250 OMH 315 OMH 400 OMH 500	151H1253	1	10
		151H1254	1	10
		151H1255	1	10
		151H1256	1	10
		151H1257	1	10
17	End cover	151H0311	1	10
18	Washer 10 x 15 x 1 mm	684X2152	7	*
19	Screw M10 x 1.5 OMH 200 OMH 250 OMH 315 OMH 400 OMH 500	681X1501	7	42
		681X1502	7	42
		681X1503	7	42
		681X1504	7	42
		681X1347	7	42
20	Name plate, aluminium	151A0411	1	10
21	Washer 13.5 x 1 mm	684X2120	2	100
22	Drain plug	151-5439	1	5
2	Spare parts bag for motors with ø1 ¹ / ₄ in and 1 ¹ / ₄ in spl. shaft	151H1100	1	30
		Dust seal ring 633B3396		
		Shaft seal, NBR 633B3395		
		O-ring 633B1528		
		O-ring (3 pcs.) 633B1807		
		Washer (7 pcs.) 684X2152		
21	Washer 684X2120			

* Indeholdt i reservedelsposen
 * Contained in spare parts bag
 * Im Ersatzteilbeutel enthalten
 * Contenu dans le sachet de pièces de rechange

** Antallet af reservedele som De bør have på lager for hver 1000 motorer der er i brug i Deres område.

** The number of spare parts to be held in stock for each 1000 motors being in service in your district.

** Die Anzahl von Ersatzteilen, die Sie für je 1000 Motoren, die in Ihrem Gebiet verwendet werden, auf Lager haben sollten.

** Les quantités de pièce de rechange que vous devez prévoir en stock pour chaque 1000 moteurs actuellement en service dans votre secteur.

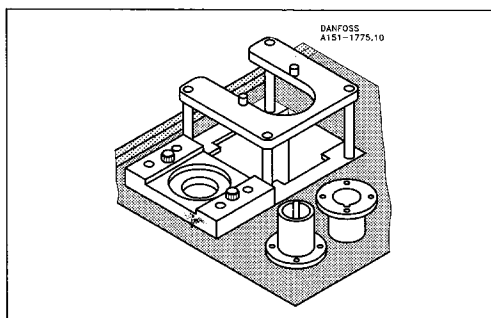
Tools

Dismantling and reassembling of OMH
Special tools:
Main holding tool (horse shoe):

Code no.: 151-9000-1.

Holding tool for bushing:

Code no.: 151-9000-2.

Bushing for \varnothing 1 1/4 in:

Code no.: 151-9000-13.

Dismantling

(Ref.: Item nos. from spare part list page 4)

Item	Part to remove	Comments
8	Parallel key	På cylindriske eller koniske aksler. <i>On cylindrical or tapered shafts.</i> An zylindrischen oder kegeligen Wellen. <i>Sur arbres cylindriques ou coniques.</i>
13	Seal plugs (2 off)	Placer motor i holdeværktøj med udgangsaksel nederst. <i>Put the motor in a holding tool, with the output shaft lowest.</i> Den Motor mit der Abtriebswelle nach unten im Haltewerkzeug anbringen. <i>Placer moteur dans l'outil arbre de sortie vers le bas.</i>
21, 22	Drain plug and washer	Benyt 19 mm topnøgle. <i>Use a 19 mm hexagon socket.</i> Einen 19 mm Steckschlüssel verwenden. <i>Utiliser clé à douille 19 mm.</i>
19, 18	Screws, washers (7 off)	Benyt 17 mm topnøgle. <i>Use a 17 mm hexagon socket.</i> Einen 17 mm Steckschlüssel verwenden. <i>Utiliser clé à douille 17 mm.</i>
17	End cover	Fjern endedækslet sideværts. <i>Remove end cover sideways.</i> Den Enddækel seitwärts entfernen. <i>Enlever le couvercle latéralement.</i>
16, 14	Gear wheel set O-rings (2 off)	Hold fingrene under tandhjulsættet for at forhindre delene i at falde ud. <i>Keep fingers under the gearwheel set to prevent the parts from falling out.</i> Die Finger unter dem Zahnradsatz halten, um zu verhindern, daß Teile herausfallen. <i>Tenir le jeu d'engrenages par dessous pour ne pas perdre de pièces.</i>
10	Cardan shaft	
15, 14	Distributor plate O-ring	

Dismantling

(Ref.: Item nos. from spare part list page 4)

Item	Part to remove	Comments
9	Output shaft	Vend herefter motoren. <i>After this, turn the motor.</i> Hiernach den Motor wenden. <i>Retourner ensuite le moteur.</i>
2	Dust seal	Anvend en 4 mm skruetrækker. <i>Use a .4 mm screw driver.</i> Einen 4 mm Schraubenzieher verwenden. <i>Utiliser tournevis 4 mm.</i>
1	Srews (6 off)	Anvend Torx-nøgle, type T 30. <i>Use a Torx-spanner, type T 30.</i> Einen TORX-Schlüssel, Typ T 30. <i>Utiliser clé Torx, type T 30.</i>
3	Spigot flange	
5, 6	O-ring, bearing race	Anvend en 2 mm skruetrækker. <i>Use a .4 mm screwdriver.</i> Einen 4 mm Schraubenzieher verwenden. <i>Utiliser tournevis 4 mm.</i>
4	Shaft seal	Slå akselpakning ud med plasthammer og 4 mm skruetrækker. <i>Knock out the shaft seal with a plastic hammer and a 4 mm screwdriver.</i> Die Wellendichtung mit Kunststoffhammer und 4 mm Schraubenzieher heraus schlagen. <i>Sortir le joint avec marteau plastique et tournevis 4 mm.</i>
7	Needle bearing	
11	Check valves (2 off)	Træk kontraventilerne ud med fx. en nedslebet (afkortet) 3,5 mm snittap. <i>Pull the check valves out with, for example, a ground (shortened) 4 mm pipe threader.</i> Die Rückschlagventile herausziehen, z.B. mit einem abgeschliffenen (verkürztem) 3,5 mm Gewindebohrer. <i>Pour les sortir, utiliser par ex. un taraud 3,5 mm (raccourci).</i>

Rensning

Rengør omhyggeligt alle dele i aromatfattig petroleum.

Kontrol og udskiftning

Kontroller omhyggeligt alle dele og skift dem ud hvis nødvendigt.

Smøring

Smør alle enkeltdele ind i hydraulikolie før samling og indfedt gummideler med vaseline.

Cleaning

Clean all parts carefully with low aromatic kerosine.

Inspection and replacement

Check all parts carefully and replace if necessary.

Lubrication

Before assembly, lubricate all parts with hydraulic oil and grease rubber parts with vaseline.

Reinigung

Alle Teile sorgfältig in aromatarmem Petroleum reinigen.

Kontrolle und Auswechslung

Alle Teile sorgfältig kontrollieren und falls notwendig, auswechseln.

Schmieren

Alle Einzelteile vor der Montage mit Hydrauliköl einschmieren, und die Gummiteile mit Vaseline einfetten.

Nettoyage

Nettoyer soigneusement toutes les pièces dans du pétrole à faible teneur en additifs.

Vérification et remplacement

Vérifier soigneusement toutes les pièces et les remplacer s'il y a lieu.

Lubrification

Avant le remontage, enduire toutes les pièces d'huile hydraulique, et graisser les pièces de caoutchouc avec de la vaseline.

Assembly

Item	Part to remove	Comments
11	Check valves	<p>Placer motorhuset i holdeværktøj med flangen øverst. Indfedt kontraventilerne (med nye O-ringe) og monter dem i boringerne med lette slag fra en plastichammer.</p> <p><i>Place the motor housing in a holding tool with the flange uppermost. Grease the check valves (with new O-rings) and place them in the borings with a light blow from a plast hammer.</i></p> <p>Das Motorgehäuse mit dem Flansch nach oben im Haltewerkzeug anbringen. Die Rückschlagventile (mit neuen O-Ringen) einfetten und mit leichten Schlägen des Kunststoffhammers in die Bohrungen montieren.</p> <p><i>Placer carter du moteur dans l'outil, bride vers le haut; graisser clapets anti-retour (nouveaux joints toriques) et les monter dans les alésages en les frappant légèrement avec marteau en plastique.</i></p>
7, 6	Needle bearing, bearing race	
4	Shaft seal	<p>Slå pakningen på plads i styreflansen. Kontroller at pakningen lægger an mod reces.</p> <p><i>Knock the seal into position in the spigot. Check that the seal lies against the cover recess.</i></p> <p>Die Dichtung im Steuerflansch an ihren Platz schlagen. Kontrollieren, ob die Dichtung an der Vertiefung des Deckels liegt.</p> <p><i>Placer le joint dans la bride de guidage et taper pour le mettre en place; s'assurer qu'il est blotti dans le recès.</i></p>
2	Dust seal	<p>Anbring støvtætningsringen i styreflansen og bank den på plads med en plastichammer og passende dorn.</p> <p><i>Place the dust seal ring in the spigot and knock it into position with a plastic hammer and an appropriate mandrel.</i></p> <p>Den Staubdichtring im Steuerflansch anbringen und mit einem Kunststoffhammer und passenden Dorn an seinen Platz schlagen.</p> <p><i>Placer le joint anti-poussière dans bride de guidage et le taper en place avec marteau en plastique et pointeau adéquat.</i></p>
5	O-ring	<p>Indfedt O-ring i vaseline. <i>Grease the O-ring with vaseline.</i> Den O-ring mit Vaseline einfetten. <i>Graisser avec de la vaseline.</i></p>
3	Spigot flange	<p>Drej så hullerne flugter. <i>Turn so that the holes line up.</i> So drehen, daß die Löcher fluchten. <i>Ajuster pour correspondance trous.</i></p>

Assembly

Item	Part to remove	Comments
1	Screws (6 off)	<p>Benyt torque nøgle, type T 30. Tilspændingsmoment: 0,5 - 0,8 daNm. Vend herefter motoren.</p> <p><i>Use a Torx spanner, type T 30. Tightening torque: 0,5 - 0,8 daNm. After this, turn the motor over.</i></p> <p>Einen Torx Schlüssel Typ T 30 verwenden. Anzugsmoment: 0,5 - 0,8 daNm. Danach den Motor wenden.</p> <p><i>Utiliser clé Torx, type T 30. Couple de serrage: 0,5 - 0,8 daNm. Retourner ensuite le moteur.</i></p>
9	Output shaft	<p>På splined aksel skal der markeres et punkt lodret over et kommuteringsspor der har forbindelse til forreste ringkanal. Se tegning. Akselsølerne smøres med hydraulikolie.</p> <p><i>The rear shaft end of splined shafts must be marked before fitted. The mark must be positioned vertically above a commutation slot leading up to the front annular channel. See drawing. Lubricate the shaft journals with hydraulic oil.</i></p> <p>An Motoren mit Vielkeilwelle muß auf dem hinteren Wellenende senkrecht über einer Kommutierungsrille, die Verbindung mit vorderem Ringkanal hat, eine Markierung gemacht werden. Siehe Zeichnung. Die Wellenzapfen mit Hydrauliköl schmieren.</p> <p><i>Pour arbres cannelés marquer au bout de l'arbre arrière la position qui se trouve verticalement à une voie de commutation liée au canal annuaire placé en tête. Voir dessin. Graisser tourillons avec huile hydraulique.</i></p>
8	Parallel key	<p>I cylindrisk eller konisk aksel. <i>In cylindrical or tapered shaft.</i> In zylindrischer oder kegelliger Welle. <i>Dans arbre cylindrique ou conique.</i></p>
14	O-ring	<p>Indfedt O-ring og læg den i husets O-ringsrille. <i>Grease the O-ring and put it in to the O-ring grooves of the housing.</i> Den O-Ring einfetten und in die O-Ring-Rille des Gehäuses legen. <i>Graisser le joint et le placer dans sa rainure le carter.</i></p>
15	Distributor plate	<p>Drej fordelerpladen, så hullerne flugter. <i>Turn the distributor plate so that the holes line up.</i> Die Verteilerplatte so drehen, daß die Löcher fluchten. <i>Adjuster la plaque de distribution pour correspondance des trous.</i></p>

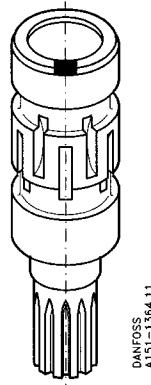

Assembly

Item	Part to remove	Comments
10	Cardan shaft	<p>Fyld olie i udgangsaksleens hul op til overkant af indvendige splines. Monter derpå kardanakslen.</p> <p><i>Fill oil in the output shaft up to the brim of the internal splines. Then install the cardan shaft.</i></p> <p>Das Loch der Abtriebswelle bis zur Oberkante der innenseitigen Korbverzahnung mit Öl füllen. Darauf die Kardanwelle montieren.</p> <p><i>Remplir l'huile par le trou de l'arbre de sortie jusqu'au rebord des cannelures intérieures. Remonter ensuite l'arbre à cardan.</i></p>
16, 14	Gearwheel set O-ring (off)	<p>Placer O-ringene (indfedtet) i tandkransens O-ringsriller.</p> <p>Placer tandhjulet med fridrejning i splineshullet til samme side som mindste skruehulsdiameter (trin hul) i tandhjulskransen.</p> <p>Monter tandhjulssættet med denne side vendt mod motoren.</p> <p>Placer tandhjulssættet på kardanakslen, så en tandtop i tandhjulets udvendige fortanding er lodret over noten i udgangsakslen (cyl. eller konisk). På motorer med splined aksel skal tandtoppen være lodret over markeringen, se pkt. 9 side 9.</p> <p>Drej tandhjulssættet mod uret indtil kardanakslen og tandhjul går i indgreb (15°).</p> <p>Drej tandhjulskransen, så hullerne til skrueerne flugter.</p> <p><i>Place the O-rings (greased) in the O-ring grooves of the gearwheel.</i></p> <p><i>Place the gearwheel with the recess in the spline hole on the same side as the smallest screw aperture diameter (step hole) in the gearwheel rim.</i></p> <p><i>Install the gearwheel set with this side turned towards the motor.</i></p> <p><i>Place the gearwheel set on the cardan shaft so that the top of a tooth in the external teeth of the gearwheel is vertically above the slot in the output shaft (cylindrical or tapered). In motors with splined shaft the tooth top must be positioned vertically above the mark, see point 9, page 9.</i></p> <p><i>Turn the gearwheel set counterclockwise until the cardan shaft and the gear wheel start to mesh (15°).</i></p> <p><i>Turn the gearwheel rim so that the holes made for the screws line up.</i></p>

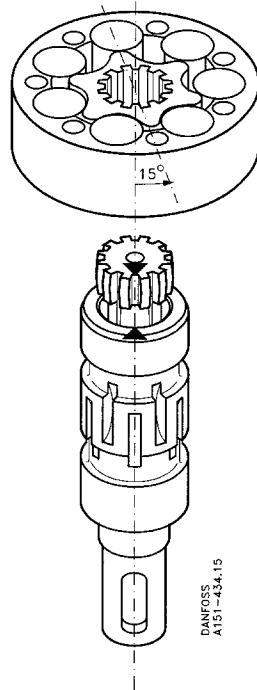

Assembly

Item	Part to remove	Comments
17	End cover	<p>Drej endedækslet så hullerne flugter.</p> <p><i>Turn the end cover so that the holes line up.</i></p> <p>Den Enddeckel so drehen, daß die Löcher fluchten.</p> <p><i>Tourner le couvercle correspondance des trous.</i></p>
18, 19	Washer, screws (7 off)	<p>Benyt 17 mm topnøgle. Tilspændingsmoment: 5,2 - 5,7 daNm</p> <p><i>Use a 17 mm hexagon socket. Tightening torque: 5,2 - 5,7 daNm</i></p> <p>Den 17 mm Steckschlüssel verwenden. Anzugsmoment: 5,2 - 5,7 daNm</p> <p><i>Utiliser clé à douille 17 mm. Couple de serrage: 5,2 à 5,7 daNm</i></p>
21, 22	Washer, drain plug	<p>Benyt 19 mm topnøgle. Tilspændingsmoment: 3 - 6 daNm</p> <p><i>Use a 19 mm hexagon socket. Tightening torque: 3 - 6 daNm</i></p> <p>Den 19 mm Steckschlüssel verwenden. Anzugsmoment: 3 - 6 daNm</p> <p><i>Utiliser clé à douille 19 mm. Couple de serrage: 3 à 6 daNm</i></p>
13	Seal plugs (2 off)	<p>Slå plastpropper i med plasthammer. Tag herefter motoren ud af holdeværktøjet. Hold eventuel feder fast med fx tape.</p> <p><i>Knock the plastic plugs in with a plastic hammer. After this, take the motor out of the holding equipment. Keep any keys secure with, for example, tape.</i></p> <p>Die Kunststoffstopfen mit dem Kunststoffhammer einschlagen. Danach den Motor aus dem Haltewerkzeug herausnehmen. Eventuell die Feder mit einem Stück Klebeband befestigen.</p> <p><i>Taper des bouchons plastique dans leurs trous respectifs avec un marteau plastique. Sortir ensuite le motor de l'outil. Maintenir en place toute clavette éventuelle avec de scotch.</i></p>

Danfoss Hydraulics Organization

Danfoss is an international concern with factories in 10 countries and subsidiaries in 32 countries. In addition to the hydraulic components, the Danfoss range of products includes refrigeration controls, industrial automatics, precision step systems, industrial instrumentations, electrical drives and controls, controls for heating plant, system controls, components for burners and boilers, compressors and thermostats for refrigerators and freezers.

Argentina	Danfoss S.A. Argentina San Lorenzo 4310 1605 Vicente Lopez Buenos Aires Tel. : 54 1 756 4200 Telex : 9900 Booth-AR Fax : 54 1 756 4100	Cyprus	Tektron Ltd. 25, Heroes Street P.O. Box 2123 Strovolos-Nicosia Tel. : 357 2 49 7907 Telex : 3968 tektron cy Fax : 357 2 31 4844	Hungary	KITE Nadudvar 4181 Nadudvar, Bem. J.U.2. Tel. : 36 54 48 0401 Telex : 72431 Fax : 36 54 48 0331
	Ing. Lahusen S.R.L. Av. Belgrano, 615 - 8° I 1092 - Buenos Aires Tel. : 54 1 342 1083/1835 Fax : 54 1 331 7314	Czech Republic Slovak Republic	TECHNO TRADE GmbH Petr Kejduš Tovarni ul. 41 CS 772 00 Olomouc Tel.: 420 68 52 22 004 Fax: 420 52 32 055	Iceland	HEDINN VERSLUN H/F Seljaveg 2 P.O. Box 512 IS-121 Reykjavik Tel. : 354 562 4260 Telex : 2003 Hedinn IS Fax : 354 562 4315 Danfoss authorized service shop
Australia	Danfoss (Australia) Pty. Ltd. Melbourne (Head Office) 1 Ricketts Road Private Bag 20, Mt. Waverley Victoria, 3149 Tel.: 61 3 9543 1033 Fax: 61 3 9543 4027 Danfoss authorized service shop	Denmark	Danfoss A/S DK-6430 Nordborg International tel.: 45 74 88 2222 National tel.: 74 88 2222 Telex : 50599 Fax : 45 74 49 0949 45 74 49 1613 (Hydr.)	India	DANTAL HYDRAULICS PVT Ltd. 805-806 Chiranjeev Tower Nehru Place New Delhi 110019 Tel.: 91 646 01 55 + 642 5036 + 645 3806 Fax: 91 11 647 6089 Danfoss authorized service shop
Austria	HAINZL INDUSTRIESYSTEME Gesellschaft m.b.H. & Co KG Industriezeile 56 P.O. Box 100 A-4040 Linz Tel. : 43 732 7892 Telex : 22 1522 Fax : 43 732 7892 150 Danfoss authorized service shop		Danfoss Hydraulik A/S Toppevadvej 44-46, Ganløse DK-3660 Sieløse Tel. : 45 42 18 4055 Telex : 40041 Sondgd dk Fax : 45 42 18 4603 Danfoss authorized service shop	Iran	Dancool Iran Co. Ltd. Piche Shemiran Kh. Tonekabon No. 15 Teheran 11488 Tel. : 98 21 7532 026 98 21 7523 835 Fax : 98 21 7530 565 Telex : 222235 dic IR
Belgium	N.V. Danfoss S.A. Erasmus Business Park Av. Joseph Wybran 45 B-1070 Bruxelles Tel. : 32 02 525 0711 Telex : 24828 Fax : 32 02 525 0757 Danfoss authorized service shop	Finland	OY Danfoss AB Kivenlahdentie 7 SF-02360 Espoo Tel. : 358 9 802 81 Fax : Hydraulics dept. 358 9 802 85 61 Danfoss authorized service shop	Israel	Radion Engineering Company Ltd. 11 Ha'sivim St. P.O.B. 7111 Petah-Tikvah 49250 Tel. : 972 3 922 6688 Telex : 3812 93 reco IL Fax : 972 3 922 6655
		France	Danfoss S.a.r.l. Z.A. de Trappes-Elancourt 7, Av. Roger Hennequin P.O. Box 58 F-78193 Trappes-Cedex Tel. : 33 1 30 62 5000 Telex : 697 809 F Fax : 33 1 30 62 5009 Danfoss authorized service shop	Italy	Danfoss s.r.l. Division Sordella Strada Carignano 48 I-10024 Moncalieri / Torino Tel. : 39 11 682 7111 Fax : 39 11 682 7199 Danfoss authorized service shop
Brazil	Danfoss do Brasil Ind. e Com. Ltda. Rua Nelson Francisco 26, Casa Verde CEP 02712-100 São Paulo Tel.: 55 11 855 5400 Fax: 55 11 855 5455 Danfoss authorized service shop	Germany	Danfoss Antriebs- und Regeltechnik GmbH Geschäftsbereich Hydraulik Carl-Legien-Str. 8 D-63073 Offenbach/Main P.O. Box 10 04 53, D-63004 Offenbach/Main Tel. : 49 069 8902 0 Telex : 4-1 52 876 Fax : 49 69 8902 319 49 69 8902 316 Danfoss authorized service shop	Japan	Danfoss K.K. Head Office Shinyokohama Mineta Bldg. 3-19, Shinyokohama 2-chome Kohoku-ku Yokohama, 222 Japan Tel. : 81 45 476 5001 Fax : 81 45 476 5010 Danfoss authorized service shop
Canada	Danfoss Fluid Power 7880 Transmere Drive Mississauga Ontario L5S 1L9 Tel. : 1 905 673 0559 Telex : 06 961216 Fax : 1 905 673 5039 Danfoss authorized service shop	Great Britain	Danfoss Limited Perivale Industrial Park Horsenden Lane South Greenford, Middx, UB6 7QE Tel. : 44 081 991 7000 Telex : 24223 Fax : 44 181 991 7053 Danfoss authorized service shop	Korea	UNITEK Corporation Korea World Trade Center P.O. Box 181 Room 201 Seokkyung Bldg. 1000-3 Daichil-Dong, Kang Nam-Ku Seoul, Korea Tel. : 82 2 567 0090 Fax : 82 2 569 2894 Danfoss authorized service shop
Chile	TALLERES LUCAS LTDA. Av. Blanco Encalada 1737 Santiago Tel.: 56 2 672 6223/695 4233 Fax: 56 2 698 2515	Greece	A. SKOURA & Co. E.E. Spirou Patsi 105 GR-118 55 Athens Tel. : 30 01 345 3906 30 01 346 3967 Telex : 216713 Deda Gr. Fax : 30-1-34 74 106 (Skouras)	Malaysia	Danfoss Industries Sdn. Bhd. No. 14, Jalan 5 Taman Perindustrian Batu Tiga 40000 Shah Alam, Selangor Tel. : 60 3 550 1685 Fax : 60 3 550 2805
China	Danfoss (Tianjin) Ltd. Wuging Development Area Road 3 Tianjin 301 700 Peoples Republic of China Tel.: (8622) 2 933 6400-06 Fax: (8622) 2 933 6407	Hong Kong	NICKO INTERNATIONAL RM. 1203, Chevalier Commercial Centre 8 Wang Hoi Road Kowloon Bay, Hong Kong Tel. : 852 2755 2783 Fax : 852 2798 8656	Mexico	Ignacio Gomez, General Manager Miller Potencia Fluida Israel 301 ESQ Damasco Col. Ricardo B. Anaya 2A Seccion Apo. Postal F-1241 San Luis Potosi, S.L.P. Mexico Tel. : 52 48 21 1937 Fax : 52 48 21 2160
Colombia	Fiza Ltda. Carrera 40 N° 163-A-55 (Toberin) Santafé de Bogotá D.C. Colombia S.A. Tel.: 57 1 677 6346/677 6440 57 1 677 5142 Fax: 57 677 7025				

Danfoss Hydraulics Organization

<p>Netherlands</p> <p>ITHO bv Adm. de Ruyterstraat 2 3115 HB Schiedam P.O. Box 21 3100 AA Schiedam Tel. : 31 010 427 8500 Telex : 23 337 Fax : 31 10 427 1534 Danfoss authorized service shop</p>	<p>Republic of South Africa</p> <p>Danfoss (Pty) Ltd. 5 Jan Smuts Park Jones Road, Jet Park Ext 28 Johannesburg Tel. : 27 11 397 1399 Fax : 27 11 397 1395 Danfoss authorized service shop</p>	<p>Thailand</p> <p>Danfoss (Thailand) Co., Ltd. 47/11 Ngam Wong Worn Road Bangkhen, Bangkok 10900 Tel. : 66 2 561 1130 Fax : 66 2 561 1446</p>
<p>New Zealand</p> <p>Danfoss (New Zealand) Limited 8 George Bourke Drive P.O. Box 12-422, Penrose MT Wellington Auckland Tel. : 64 9 270 2110 Fax : 64 9 270 2112 Danfoss authorized service shop</p>	<p>Singapore</p> <p>Danfoss Industries Pte. Ltd. 6 Jalan Pesawat Singapore 619364 Tel. : 65 261 4088 Fax : 65 261 0488 Danfoss authorized service shop</p>	<p>Turkey</p> <p>MERT TEKNİK FABR. MALZEMELERİ TICARET ve SANAYİ A.Ş. Tersane Cad. No. 43 80000 Karaköy - İstanbul Tel. : 90 0 212 252 8435 Telex : (18) 931 251 Fax : 90 0 212 245 63 69 Danfoss authorized service shop</p>
<p>Norway</p> <p>Danfoss A/S Årenga 2 N-1314 Skui Tel. : 47 67 13 5680 Fax : 47 67 13 6850 Danfoss authorized service shop</p>	<p>Slovenija</p> <p>Technical Office Klun Ul Bratov Martinec 16 61000 Ljubljana Slovenija Tel. : 386 61 127 1624 Fax : 386 1 10 8139</p>	<p>U.S.A.</p> <p>Danfoss Fluid Power Division of Danfoss Inc. North American Headquarters 8635 Washington Avenue Racine, Wisconsin 53406 Tel. : 1 414 884 7400 Fax : 1 414 884 7440 Danfoss authorized service shop</p>
<p>Poland</p> <p>Danfoss Sp. z o.o. ul. Obozowa 20, 01-161 Warszawa Tel. : 632 00 75, 632 39 81, 632 43 84 Telex : 815777 dfoss pl Fax : 632 69 32 KOMERTEL: 39 12 12 51, 39 12 32 91</p>	<p>Spain</p> <p>Danfoss S.A. Avda. Tenerife No. 22 Pol. Ind. Norte 28700 San Sebastian de los Reyes (Madrid) Tel. : 34 1 663 8051 Fax : 34 1 663 7570 Danfoss authorized service shop</p>	<p>Danfoss Fluid Power Division, Easley Operations 1201 Pelzer Highway P.O. Box 2189 Easley, South Carolina 29640 Tel. : 1 864 855 2884 Fax : 1 864 855 5885 (general) 1 864 850 6010 (executive office)</p>
<p>Portugal</p> <p>Danfoss (Portugal), Lda. Av.do Forte, 8-1º P Edificio Pujol P-2795 Carnaxide Tel. : 351 1 417 2455/65 Telex : 12872 danfos p Fax : 351 1 417 2466</p>	<p>Sweden</p> <p>Danfoss AB Brita Sahlgrens Gata 8C Box 9143 40093 Göteborg Tel. : 031 709 27 00 Fax : 031 709 27 49 Danfoss authorized service shop</p>	
<p>Rumania</p> <p>Michail Petrache S.C. LYRA PRODIMPEX Ltd. B-dul Timisoara 41 Bl. P14, Sc. B. Ap. 24 773621 BUCURESTI Tel. : 401 323 8373, 401 323 8379 Fax : 401 323 8399</p>	<p>Switzerland</p> <p>Danfoss Werner Kuster AG Parkstrasse 6 CH-4402 Frenkendorf Tel. : 41 061 901 1515 Fax : 41 061 901 4180 Danfoss authorized service shop</p>	
<p>Russia</p> <p>ZAO Danfoss Marksistskaya ul. 34 109147 Moscow Tel. : 7 095 792 5757 7 501 792 5757 (Satellite) Fax : 7 095 792 5760 7 501 792 5760 (Satellite)</p>	<p>Taiwan</p> <p>Symbridge Machinery Co. Ltd. 28 Lane 205, Sec. 3 Chung Ching North Road P.O. Box 47-132 Taipei/Taiwan R.O.C. Tel. : 886 02 591 0816 8 (three lines) Telex : 19437 SYMBRI Fax : 886 02 591 4190</p>	

ACX104C

Potentiometer Rotary Position Sensor

BLN-95-8939-8

Issued: January 1995

DESCRIPTION

The ACX104C Potentiometer Rotary Position Sensor is designed for use as a steering feedback sensor on mobile equipment with automatic steering control systems. The ACX104C follows steering action of the wheels or tracks through rotation of its input shaft. The input shaft is coupled to an internal single or dual potentiometer drive.

Options to the basic ACX104C include single or dual potentiometer drive, resistance of potentiometers, physical stops for rotational input, active sector of rotation and flange/stud mount.



FEATURES

- Rugged housing, designed to withstand the vibration associated with mobile equipment
- Protected against moisture and dust
- Wiring connections made through MS connector or bare wires.
- Easy to install

TECHNICAL DATA

MAXIMUM INPUT VOLTAGE
24 Vdc

ACTIVE ROTATIONAL SECTOR
Customer specified: 90°, 312° or 342°

POTENTIOMETER RESISTANCE
Customer specified: 1, 10, 20 kilohms

CENTERING ACCURACY
With the longer end of the shaft roll pin centered between the case stops, the potentiometer will be centered in its electrical travel within $\pm 5\%$ of total resistance.

ENVIRONMENTAL

OPERATING AMBIENT TEMPERATURE RATING
0° - 93° C (32° - 200° F)

VIBRATION

Withstands a vibration test designed for mobile equipment devices that includes two parts:

1. Cycling from 5 to 2000 Hz over a range of ± 1.0 g's to ± 8.0 g's for a period of one hour (if there are four resonant points), for two hours (if there are two or three resonant points) and for three hours (if there is one or no resonant point). The cycling test is performed on each of the three major axes.
2. Resonance dwell for one million cycles over a range of ± 1.0 g's to ± 8.0 g's for each of the four most severe resonant points on each of the three major axes.

SHOCK

Withstands a shock test for mobile equipment devices that consists of three shocks of 50 g's and 11 milliseconds duration in both directions of the three major axes for a total of 18 shocks.

WEIGHT

1.0 kg (2.25 lbs.)

DIMENSIONS

See the Dimension drawing.

ORDERING INFORMATION

SPECIFY

1. Part Number: ACX104CXXXX
2. Controller if needed: ACE100B or R7232A
 - A. For steering feedback into an ACE100B Controller using potentiometer inputs, one of the 1000 ohm options is selected.
 - B. For steering feedback into an R7232A Controller, a 20,000 ohm potentiometer is required. The ganged 1000 ohm section is used for steering alignment.
3. Sensor if needed: SB104A
4. Servovalve if needed: KVFXXXXXX
5. Cable if needed: KW01009, KW01007

ORDERING INFORMATION (continued)

ORDER NUMBER	APPLICATION	OHMS	POTENTIOMETER	MOUNT	CONNECTOR
ACX104C1001	Steering Fdbk	1K, 20K	312°, 312°	Flange	6 Pin MS
ACX104C1100	Position Fdbk	1K	312°	Flange	6 Pin MS
ACX104C1118	Angular Position	1K	342°	Flange	Coil Cord
ACX104C1126	Steering Fdbk	1K	90°	Flange	6 Pin MS
ACX104C1134	Transducer	50K	300°	Flange	10 Pin MS
ACX104C1152	Steering Fdbk	1K	312°	Flange	6 Pin MS
ACX104C1167	Angular Position	1K	342°	Flange	Coil Cord
ACX104C1191	Position Sensor	1K	90°	Flange	3 Pin Packard
ACX104C1209	Steering Fdbk	20K	342°	Flange	3 Pin Packard
ACX104C1217	Position Sensor	1K	90°	Flange	4 Pin MS
ACX104C1225	Steering Fdbk	20K	342°	Flange	4 Pin MS
ACX104C1233	Position Sensor	1K	90°	Flange	4 Pin MS
ACX104C1241	Steering Fdbk	20K	342°	Flange	3 Pin Packard
ACX104C1258	Steering Fdbk	1K	90°	Flange	6 Pin MS

BLOCK DIAGRAM

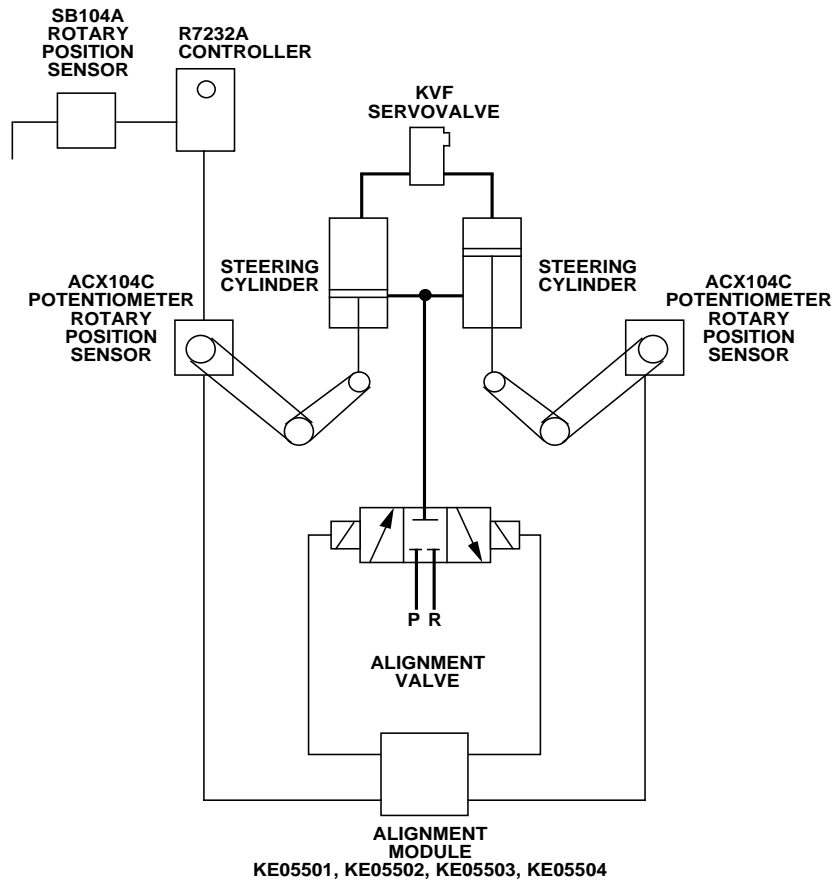

— Bold lines represent hoses.

1374A

Typical Steering Control System For a Steerable Track or Wheel Vehicle, Including Alignment. The Two Pictured Cylinders Control the Left and Right Front Tracks.

DIMENSIONS

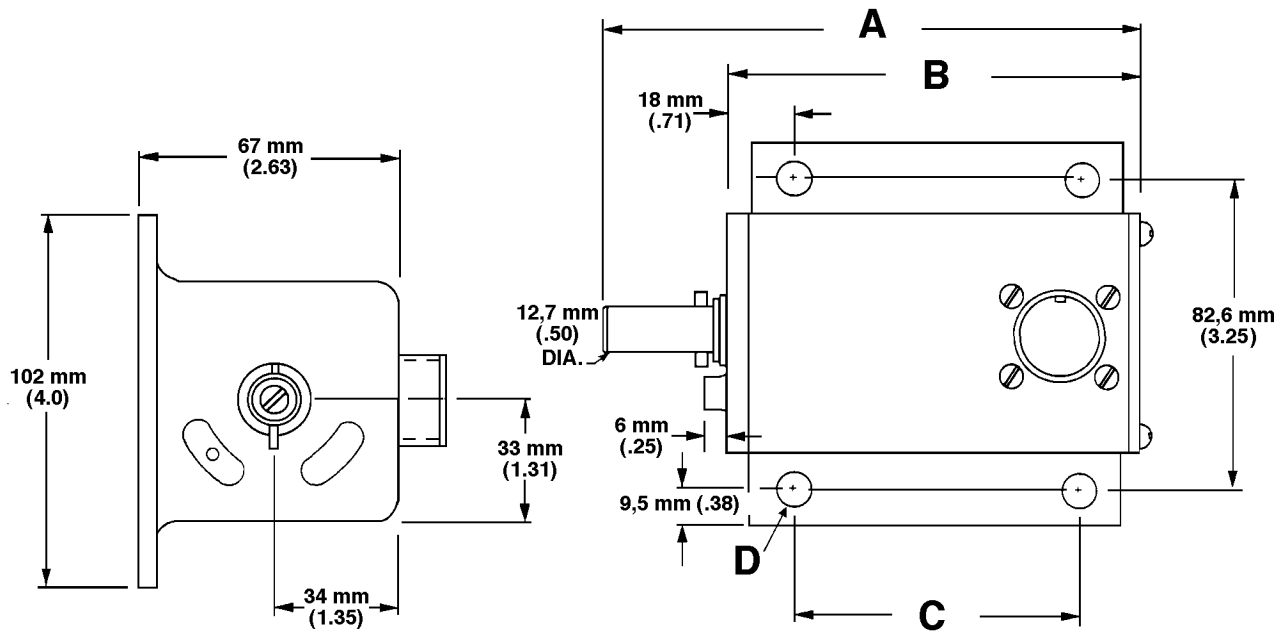

MODEL	DIMENSION A	DIMENSION B	DIMENSION C	DIMENSION D
ACX104C1209	142 mm (5.6 inches)	107 mm (4.2 inches)	70 mm (2.8 inches)	6 mm (0.24 inch)
ACX104C1225,1233	140,97 mm (5.55 inches)	105,41 mm (4.15 inches)	76,2 mm (3.0 inches)	8,64 mm (0.34 inch)
ACX104C1134	169,67 mm (6.68 inches)	134,11 mm (5.28 inches)	76,2 mm (3.0 inches)	8,13 mm (0.32 inch)

278B

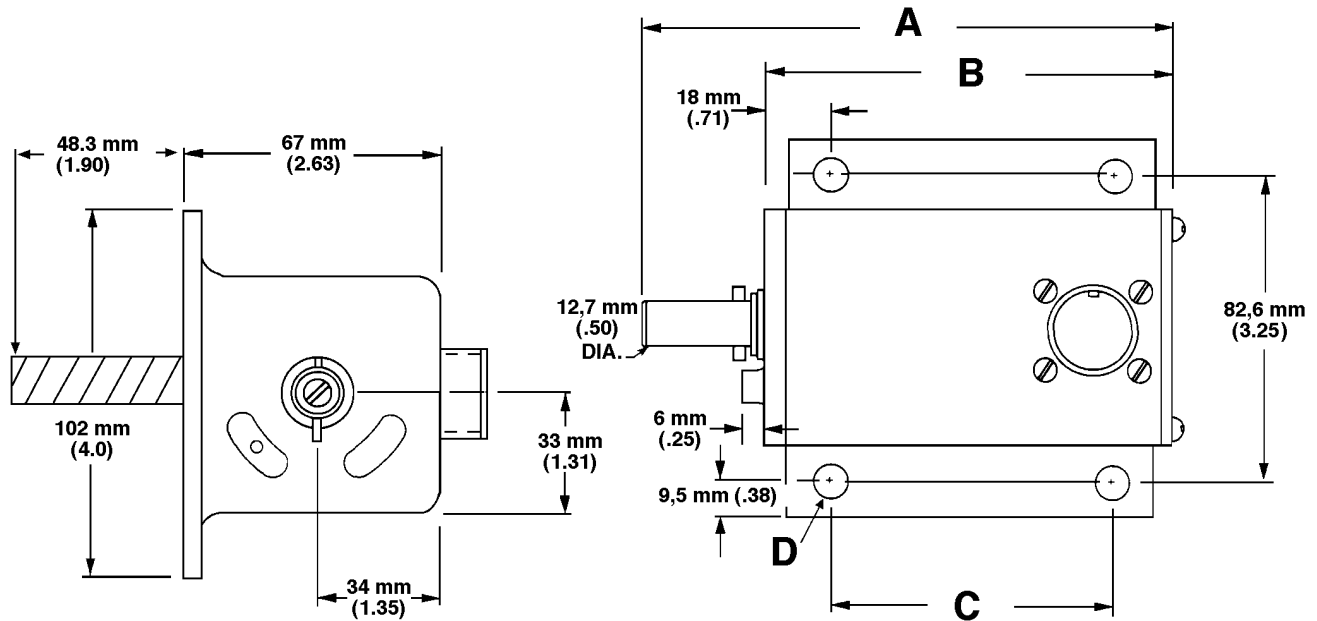

MODEL	DIMENSION A	DIMENSION B
ACX104AC1068	157.48 mm (6.2 inches)	121.92 mm (4.8 inches)

1798

Dimensions of the ACX104C in Millimeters (Inches).

DIMENSIONS (continued)

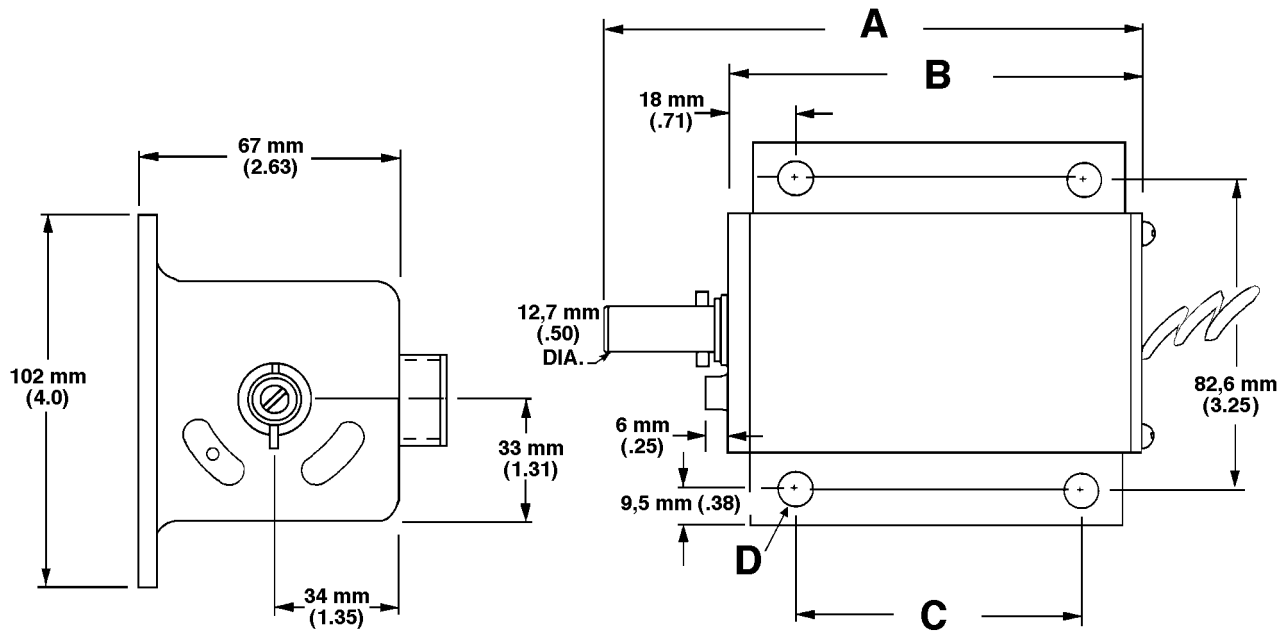

MODEL	DIMENSION A	DIMENSION B	DIMENSION C	DIMENSION D
ACX104C 1191, 1167 1118, 1100, 1084, 1241	157.48 mm (6.2 inches)	121.92 mm (4.8 inches)	76.2 mm (3.00 inches)	8.128 mm (.32 inch)

Dimensions of the ACX104C in Millimeters (Inches).

1799

THEORY OF OPERATION

The ACX104C Potentiometer Rotary Position Sensor provides steering angle position information in automatic steering control systems, with a typical example shown in the Block Diagram. The function of the steering system is to maintain the machine frame at a constant distance from the string line or other steering reference. To do so, the machine position is detected through a vertical sensing wand attached to an SB104A Rotary Position Sensor. Changes in the machine tracking line cause the steering sensor hub to rotate, sending a signal to the R7232A Controller. This signal is compared in the Controller with another signal from the ACX104C track position feedback sensor (necessary to stabilize steering) and the Controller's output is fed to the KVF Servovalve for corrective action from the steering cylinder. Two of these systems, one front and one back, are necessary to maintain proper alignment along the string line.

A second steering function is provided by the automatic front track alignment system, which provides an electronic "tie rod" feature. Using a track position feedback transducer on the left front track and an identical transducer on the right front track, the KE05501, KE05502, KE05503, or KE05504 alignment module compares the steering angle of both tracks. Internal logic allows the alignment module to maintain the proper ratio of left-to-right track pivot throughout full turning range.

INSTALLATION

MOUNTING

Two mounting styles are available. If the mounting stud is chosen, a half-inch (1/2-13 UNC-2A thread) bolt extending from the case is a rotatable mounting.

If the flange mount is chosen, use four quarter-inch bolts to attach the back plate to the machine, with the hole pattern as shown in the Dimension drawing. In either mounting style, the sensor can be oriented in any position dictated by the application.

The most common means of attaching the input shaft to the steering post is with a chain and sprocket, with the ratio of post movement to feedback sensor shaft rotation selected by the user.

WIRING

If electrical wheel alignment (using the KE05501, KE05502, KE05503 or KE05504 alignment module, described in the section "Theory Of Operation") is desired, a ganged dual potentiometer drive ACX104C should be specified. If a simple steering system is the application, a single potentiometer is sufficient.

The appropriate cable is the KW01009, (a two-foot coiled cable that extends to ten feet). The KW01007 is similar, but extends to twenty feet.

CONNECTION DIAGRAM

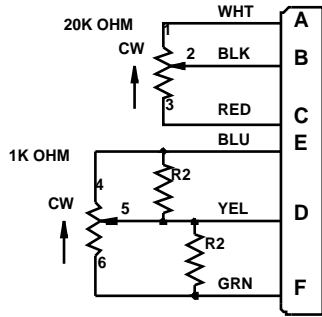

ACX104C1001

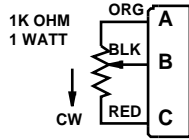

ACX104C1068

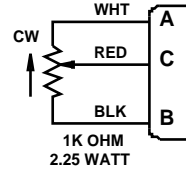

ACX104C1100

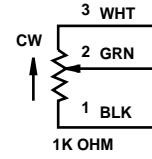

ACX104C1118

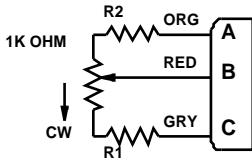

ACX104C1152

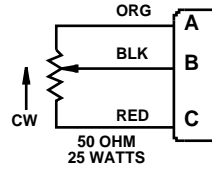

ACX104C1134

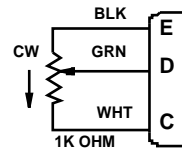

ACX104C1167

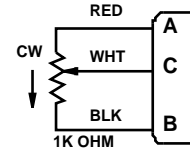

ACX104C1191

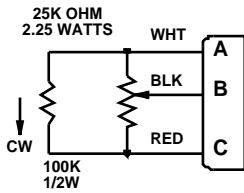

ACX104C1084

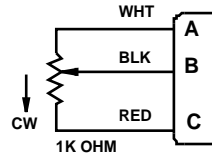

ACX104C1142

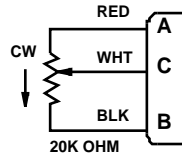

ACX104C1209

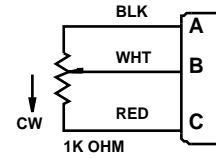

ACX104C1217

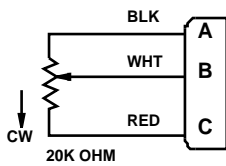

ACX104C1225

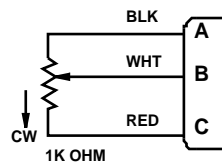

ACX104C1233

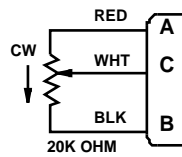

ACX104C1241

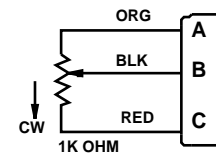

ACX104C1258

1797

Dual and Single Potentiometer ACX104C Schematics.
The Wipers on Pins B, C and D (As Appropriate) Are Moved by Shaft Rotation.

CUSTOMER SERVICE

NORTH AMERICA

ORDER FROM

Sauer-Danfoss (US) Company
Customer Service Department
3500 Annapolis Lane North
Minneapolis, Minnesota 55447
Phone: (763) 509-2084
Fax: (763) 559-0108

DEVICE REPAIR

For devices in need of repair, include a description of the problem, a copy of the purchase order and your name, address and telephone number.

RETURN TO

Sauer-Danfoss (US) Company
Return Goods Department
3500 Annapolis Lane North
Minneapolis, Minnesota 55447

EUROPE

ORDER FROM

Sauer-Danfoss (Neumünster) GmbH & Co.
Order Entry Department
Krokamp 35
Postfach 2460
D-24531 Neumünster
Germany
Phone: 49-4321-8710
Fax: 49-4321-871-184

**SYSTEM FIVE****CONTROL BOX 9164**

Doc. #7011-0104 Rev. C ECO #2220

DESCRIPTION

- The System Five Control Box is a dual-function, machine control platform featuring the latest operator interface and proportional valve control technologies.
- The System Five Platform is capable of hosting a wide range of application-specific software. The new control box is field reprogrammable and backwards compatible with System Four sensors. Simple design and a large, high resolution LCD screen allows for easy-to-use menus and functions for many types of construction and agricultural applications.

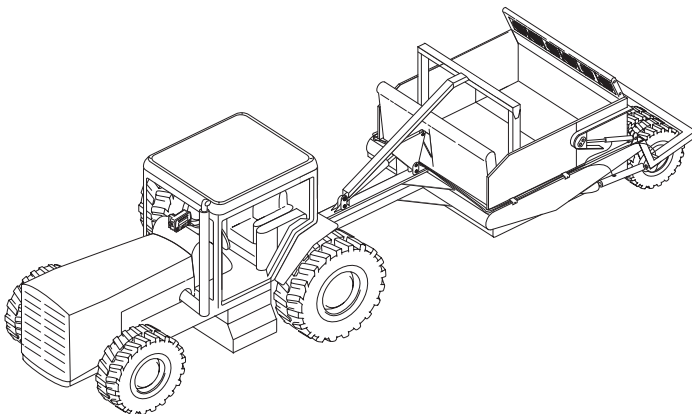
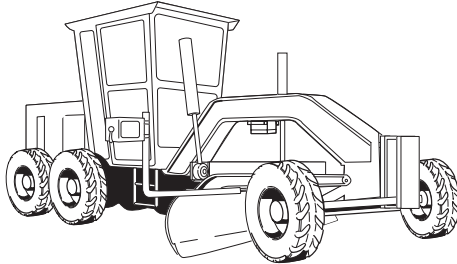
**FEATURES**

- Current Regulated proportional outputs
- Large backlit LCD Digital Display
- Tough embedded membrane switches
- Fingertip selected menus and functions
- Bright adjustable 3-color LED grade lights
- Convenient, out-of-the-way mounting
- Optional remote switch boxes
- FLASH download capability (application code revisions)
- Additional communications bus for input and display accessories

TOPCON Positioning Systems, Inc.
7400 National Drive • Livermore, CA • 94551
© Copyright 2004 Topcon Positioning Systems Inc.



SPECIFICATIONS

ELECTRICAL

SUPPLY VOLTAGE	10-30V DC
SUPPLY CURRENT	.5A Typical operating current 10.5A Maximum operating current
EMISSIONS	Applicable regulation: EN55022:1994 30-230MHz 40.0dB (mV/m) Max at 10m 230-1000MHz 47.0dB (mV/m) Max at 10m
IMMUNITY	Applicable regulation: EN50082-1:1997 ESD: ±8KV RF: 80-1000MHz 3 V/m Fast transient: ±.5KV capacitively coupled RF common mode: 3V 150kHz to 8MHz (80% 1kHz AM)
SWITCHED OUTPUT POWER	10A max Valve output power 5A max Sensor output power 10A max Total combined output current
NETWORK	Topcon proprietary RS-485 network port Hardware controlled RS-232C port 2 wire serial bus for auxiliary I/O (non mission critical apps only)

PHYSICAL

DISPLAY	240 X 64 STN LCD graphic display with EL backlight Note: See envelope dimensions for viewing angles
HOUSING	Cast aluminum Note: See envelope dimensions section
SWITCHES	7 ea. 1 million cycle 12oz 12mm stainless steel dome membrane 1 ea. sealed rocker single pole 2 ea. 32 position rotary encoder w/gold contacts, o-ring seal



SYSTEM FIVE

CONTROL BOX **9164**

Doc. #7011-0104 Rev. C ECO #2220

CONNECTORS

Application specific
MIL-C-5015 cylindrical connectors
Gold Plated Contacts
Conductive anticorrosive coating

ENVIRONMENTAL

OPERATING TEMPERATURE -20°C to 60°C

MOISTURE Mil Std 810D, method 506
95% humidity at 60° soak

SHOCK 50G 6 axis 1/2 sine 11ms

VIBRATION 10-100Hz sweep 5G's
Natural resonance frequency ~40Hz

VALVE OUTPUTS

Four valve outputs (2 bidirectional hydraulic cylinders)

CURRENT CONTROLLED PROPORTIONAL MODE 0-5A in 16 scale settings
Programmable dither, 0-112Hz, 0-25%
Sink or source operation

PULSE WIDTH MODULATED PROPORTIONAL MODE 244-1700 Hz programmable
Programmable dither, 0-112Hz, 0-25%
Programmable current limit
Sink or source operation

SERVO VALVE MODE Programmable current limit
Sink/source operation

SOLENOID (ON/OFF) MODE 2-14Hz
Programmable current limit
Sink or source operation

DANFOSS™ PROPORTIONAL MODE 50% available voltage as neutral
> 50%=Raise, < 50%=Lower
Programmable dither, 0-112Hz, 0-25%



SYSTEM FIVE

CONTROL BOX 9164

Doc. #7011-0104 Rev. C ECO #2220

SERVICE PARTS

FOR PART NUMBERS:

9164-0002
-0003

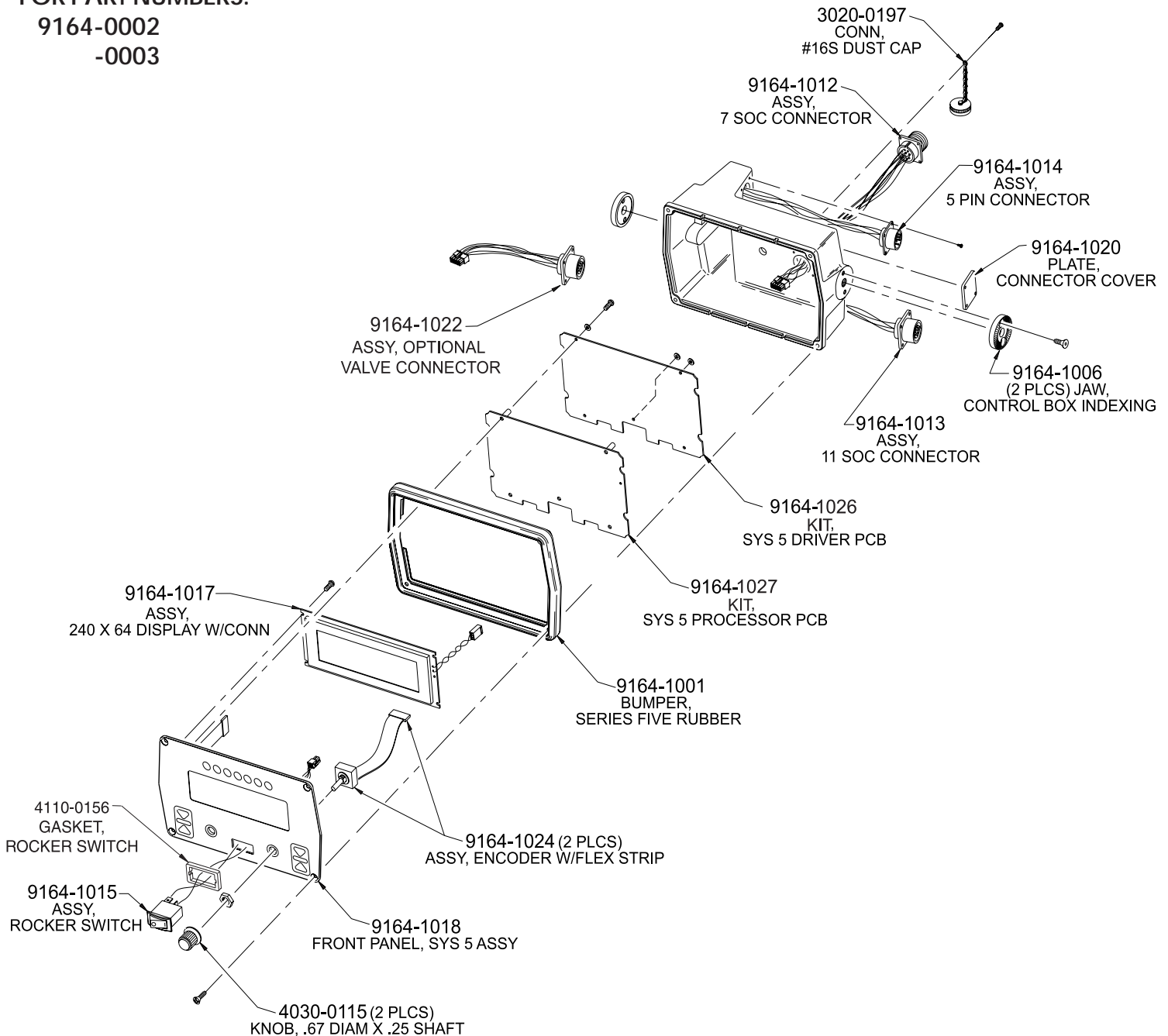

TOPCON Positioning Systems, Inc.

7400 National Drive • Livermore, CA • 94551

© Copyright 2004 Topcon Positioning Systems Inc.

Specifications subject to change without notice



SYSTEM FIVE

CONTROL BOX 9164

Doc. #7011-0104 Rev. C ECO #2220

CONNECTOR PINOUTS

FOR PART NUMBERS:

9164-0002
-0003

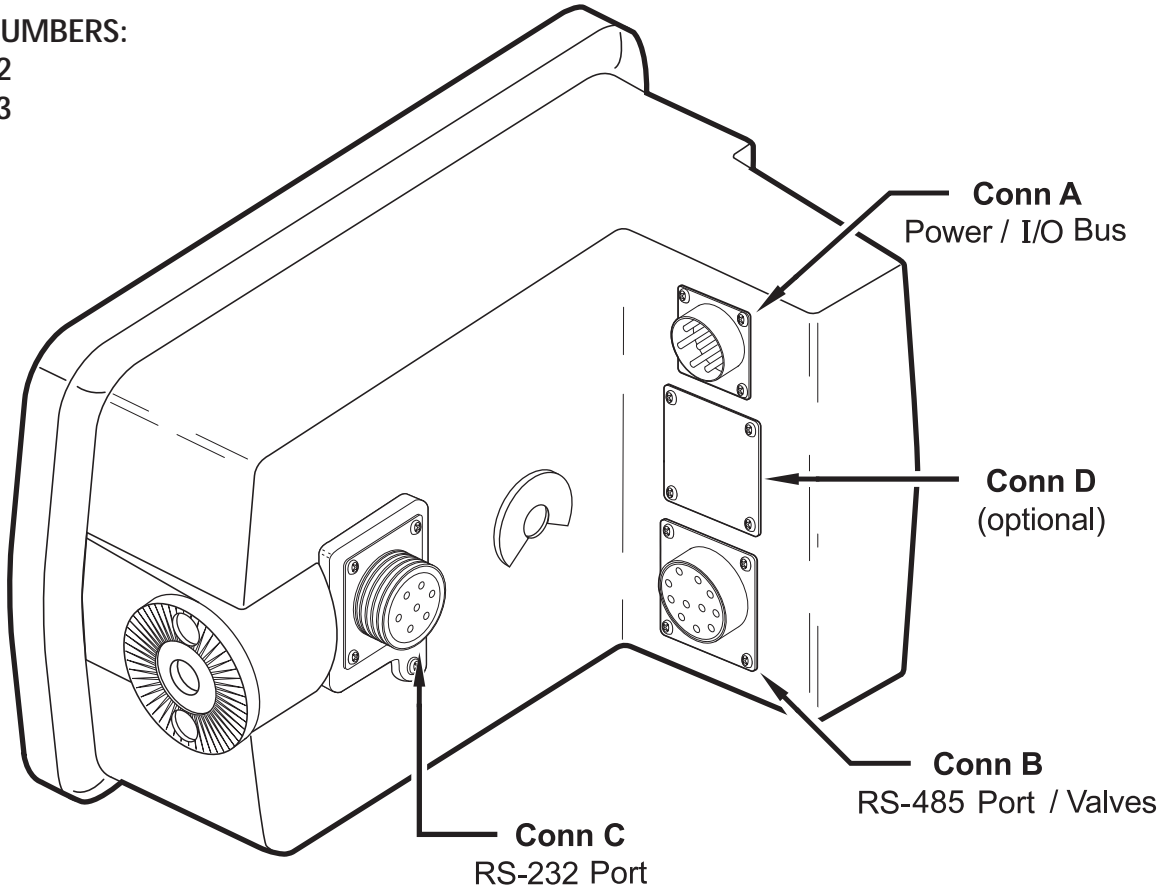

Conn A (14-5 Pin Bay)	
A	V Batt
B	Clock/Auto RT
C	Data/Auto LF
D	V Supply
E	Ground

Conn B (18-11 Soc Bay)	
A	Comm A
B	Comm B
C	V Swit
D	Gnd
E	Motor Valve Power
F	Motor Valve Gnd
G	Raise (Front/Left)
H	Raise (Rear/Right)
J	Lower (Front/Left)
K	Lower (Rear/Right)
L	None

Conn C (16-7 Soc Scr)	
A	RX
B	TX
C	RTS
D	CTS
E	Batt Unswit
F	V Swit
G	Gnd

Conn D (Opt) (18-10 Soc Scr)	
A	V Swit
B	V Swit
C	V Swit
D	V Swit
E	Raise (Front/Left)
F	Raise (Rear/Right)
G	Lower (Front/Left)
H	Lower (Rear/Right)
I	Gnd
J	Gnd

TOPCON Positioning Systems, Inc.
7400 National Drive • Livermore, CA • 94551
© Copyright 2004 Topcon Positioning Systems Inc.

Specifications subject to change without notice



SYSTEM FIVE

CONTROL BOX 9164

Doc. #7011-0104 Rev. C ECO #2220

SERVICE PARTS

FOR PART NUMBERS:

9164-0001
-0004

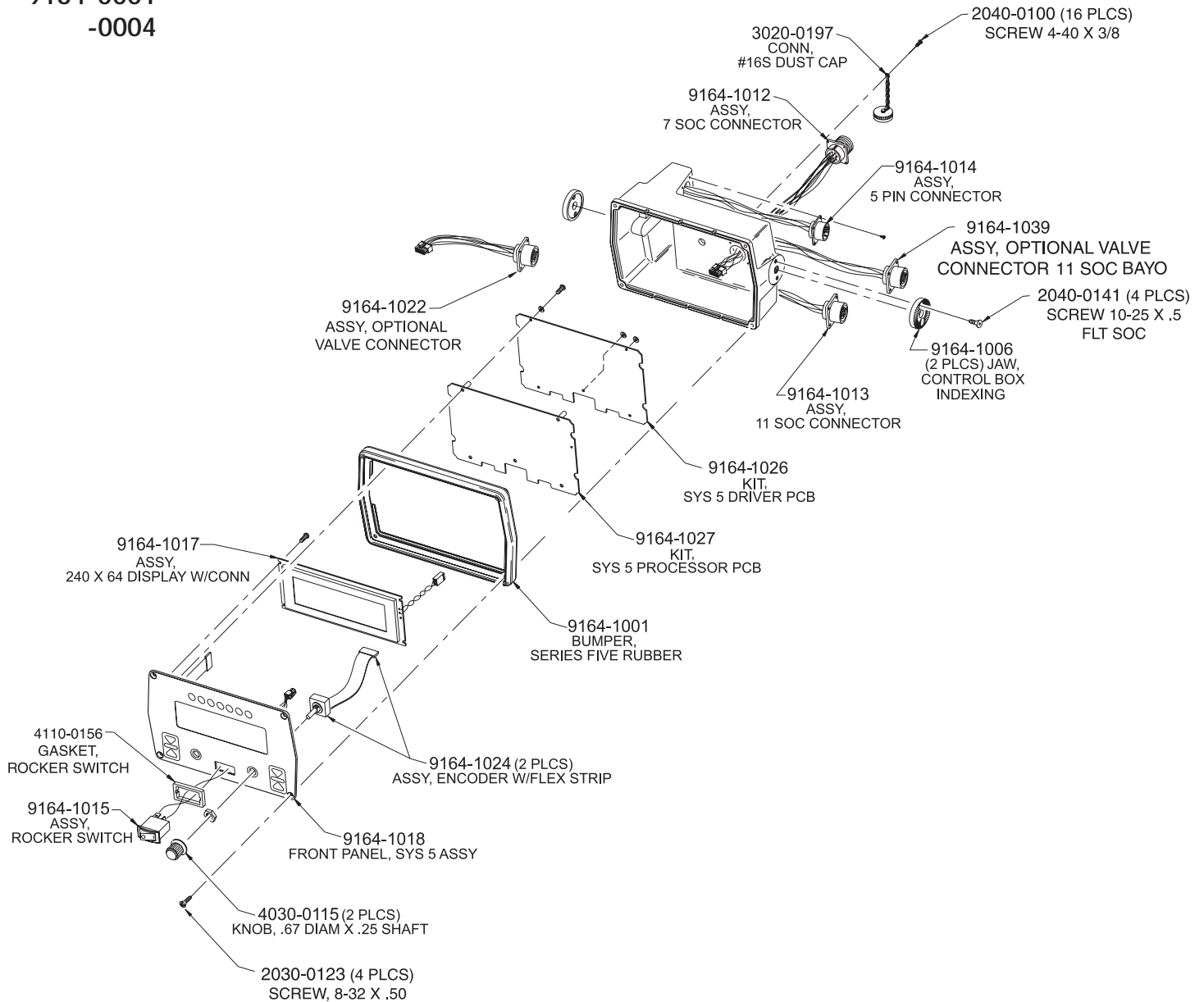

TOPCON Positioning Systems, Inc.

7400 National Drive • Livermore, CA • 94551

© Copyright 2004 Topcon Positioning Systems Inc.

Specifications subject to change without notice



SYSTEM FIVE

CONTROL BOX 9164

Doc. #7011-0104 Rev. C ECO #2220

CONNECTOR PINOUTS

FOR PART NUMBERS:

9164-0001
-0004

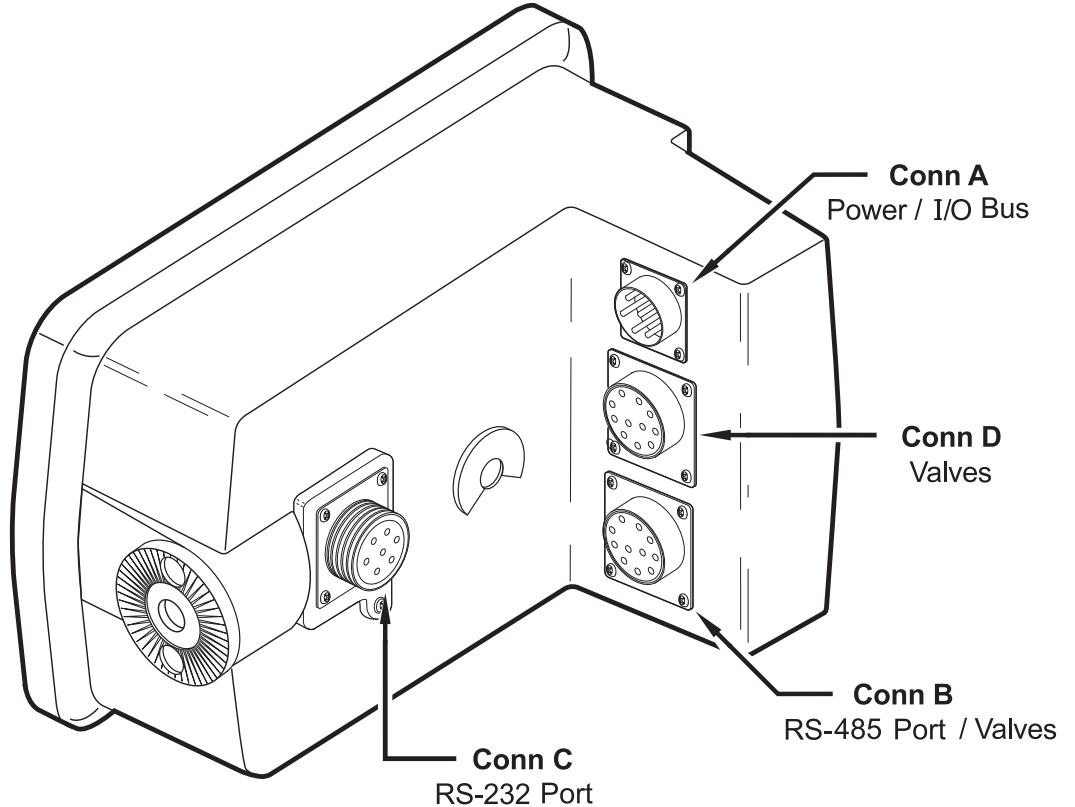

Conn A (14-5 Pin Bay)	
A	V Batt
B	Clock/Auto RT
C	Data/Auto LF
D	V Supply
E	Ground

Conn B (18-11 Soc Bay)	
A	Comm A
B	Comm B
C	V Swit
D	Gnd
E	Motor Valve Power
F	Motor Valve Gnd
G	Raise (Front/Left)
H	Raise (Rear/Right)
J	Lower (Front/Left)
K	Lower (Rear/Right)
L	None

Conn C (16-7 Soc Scr)	
A	RX
B	TX
C	RTS
D	CTS
E	Batt Unswit
F	V Swit
G	Gnd

OR	
Conn D (Optional) (11 Soc Bayo)	
A	V Swit
B	V Swit
C	V Swit
D	V Swit
E	Raise (Front/Left)
F	Raise (Rear/Right)
G	Lower (Front/Left)
H	Lower (Rear/Right)
I	Gnd
J	Gnd

Conn D (Optional) (11 Soc Bayo)	
A	V Power
B	V Power
C	Gnd
D	Gnd
E	Gnd
F	Gnd
G	Raise (Front/Left)
H	Raise (Rear/Right)
J	Lower (Front/Left)
K	Lower (Rear/Right)



TYPICAL MOUNTING DETAIL

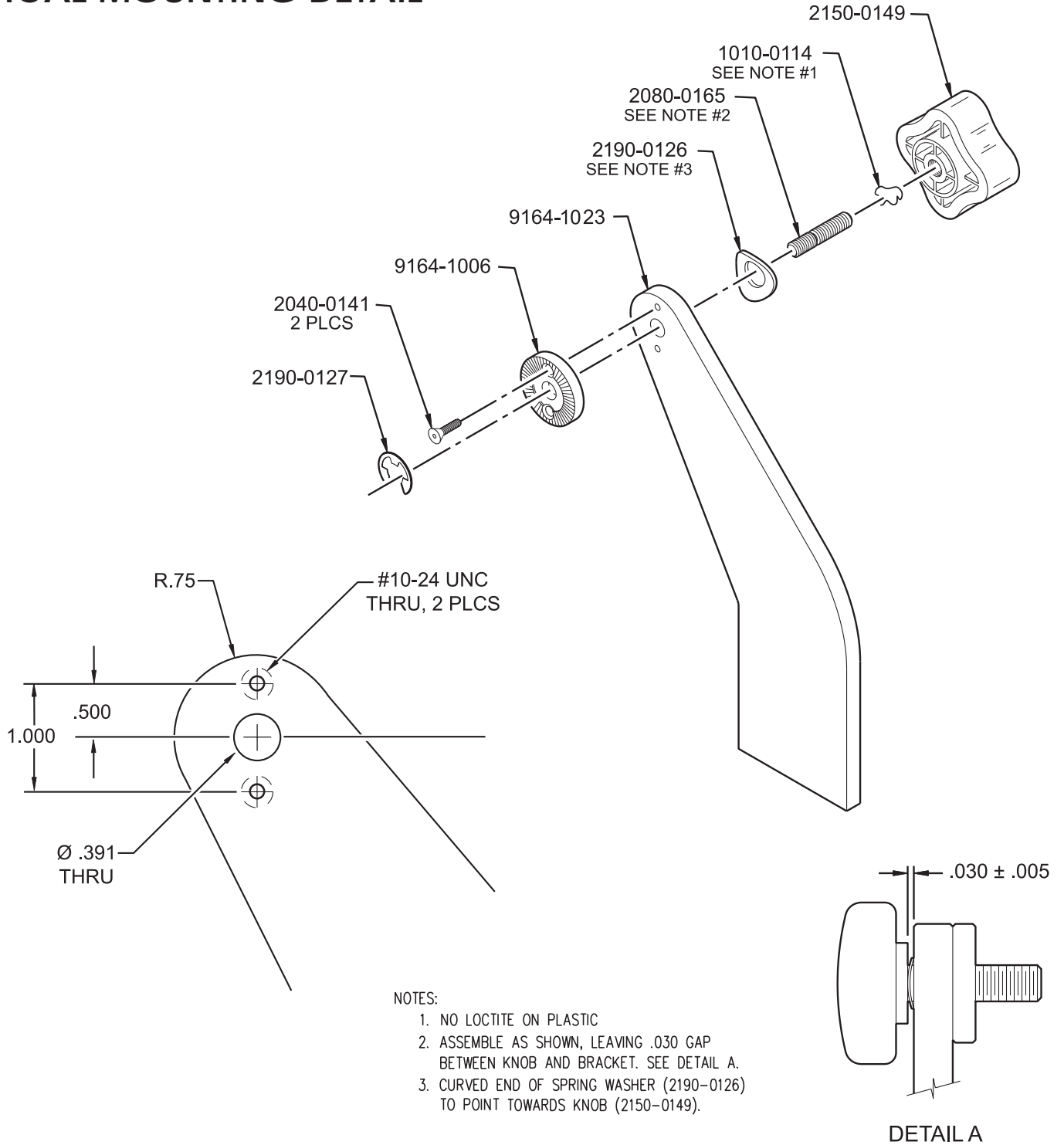



ENVELOPE DIMENSIONS

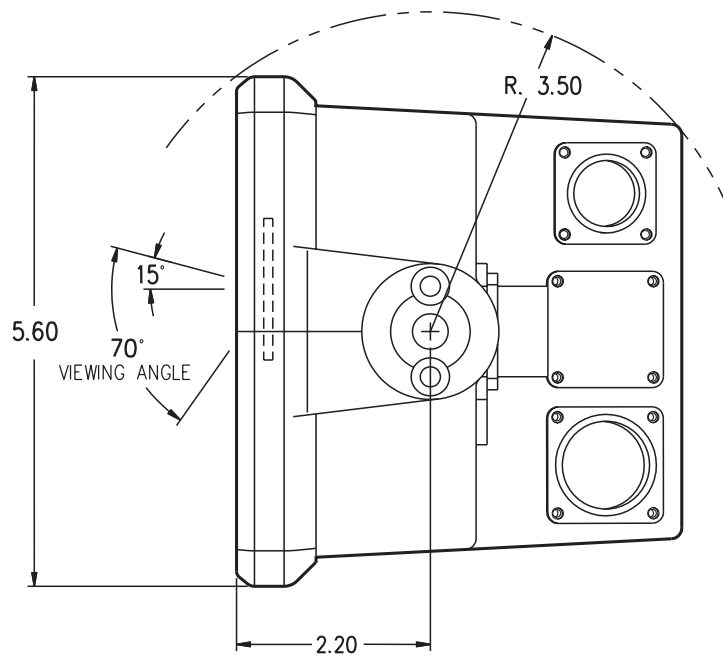
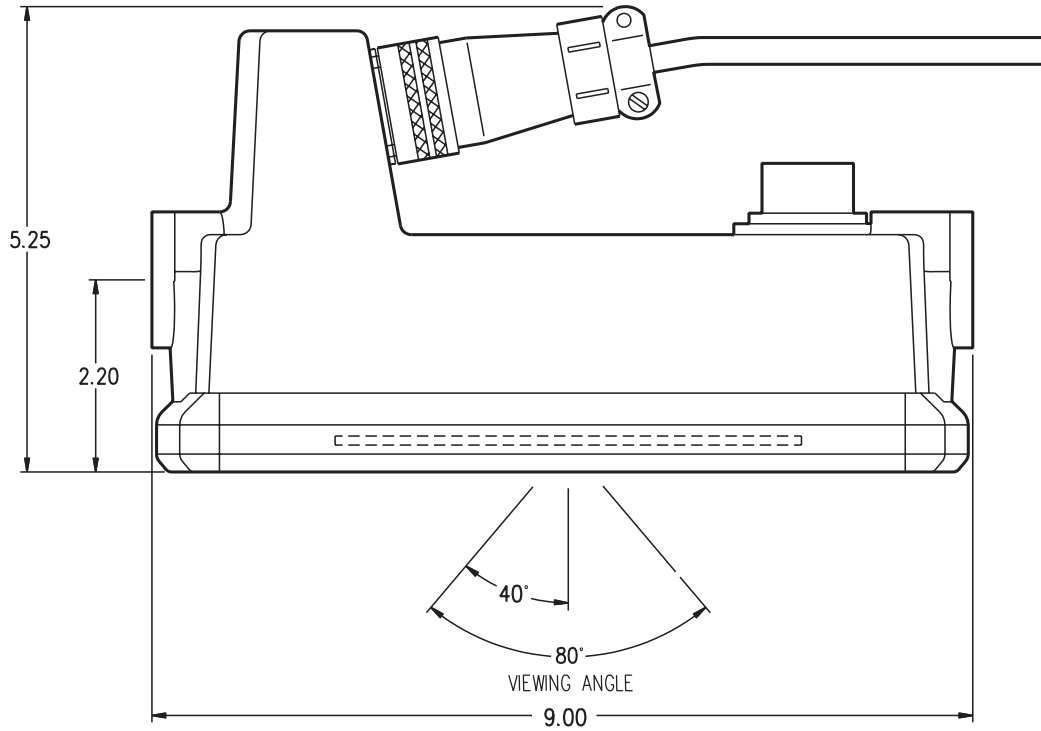

TOPCON Positioning Systems, Inc.

7400 National Drive • Livermore, CA • 94551

© Copyright 2004 Topcon Positioning Systems Inc.

Specifications subject to change without notice



SYSTEM FOUR PLUS SLOPE SENSOR 9150P/9152P

Doc. #7011-0105 Rev. B ECO #2472

DESCRIPTION

- The 9150P\9152P slope sensor allows for precise measurement of cross slope whenever needed by a System Four or System Five application. The sensor follows the System Four RS-485 communication protocol developed by Topcon to provide the first digital communication system available for construction machine automation.
- The 9150P\9152P features a temperature compensated sensing element to provide superior performance in any condition.

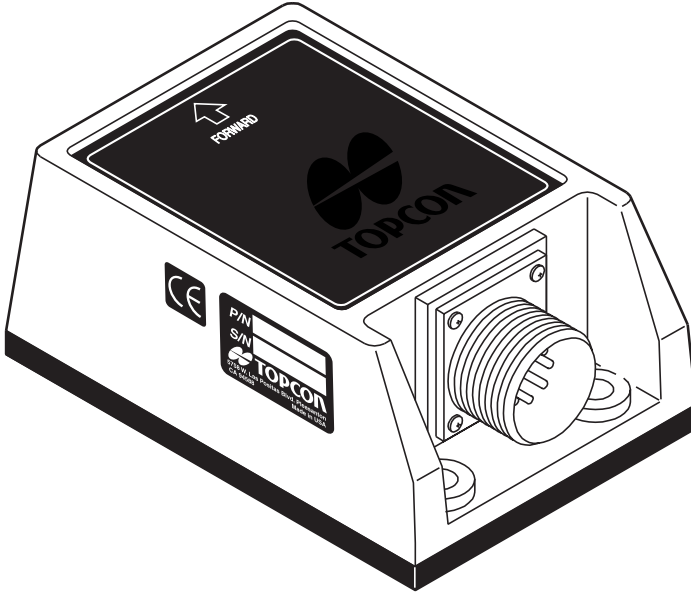

FEATURES

- Superior accuracy and response
- Rugged sealed electronics
- Compatible with all System Four and System Five Control Boxes

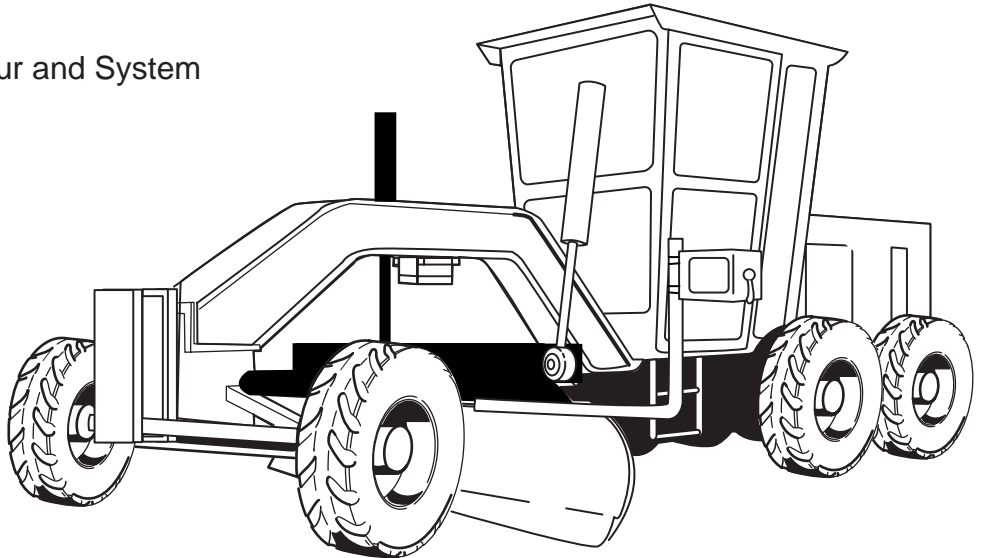

TOPCON Positioning Systems, Inc.

7400 National Drive • Livermore, CA • 94551 (925) 245-8300 • FAX (925) 245-8583

© Copyright 2005 Topcon Positioning Systems Inc.

Specifications subject to change without notice



SYSTEM FOUR PLUS

SLOPE SENSOR 9150P/9152P

Doc. #7011-0105 Rev. B ECO #2472

SPECIFICATIONS

ELECTRICAL

RESOLUTION	+/- 0.025% slope	
RANGE	9150P	+/- 0-20% slope
	9152P	+/- 0-100% slope
SUPPLY VOLTAGE	10-30 VDC	
SUPPLY CURRENT	200mA	Typical operating current
EMISSIONS	Applicable regulation: EN55022:1994	
	30-230MHz	40dB (mV/m) Max at 10m
	230-1000MHz	47dB (mV/m) Max at 10m
IMMUNITY	Applicable regulation: EN50082-1:1992	
	ESD:	±8KV
	RF:	27 to 500MHz 3V/m
	Fast transient:	±0.5KV capacitively coupled
NETWORK	Topcon proprietary RS-485 network port	

PHYSICAL

HOUSING	Cast aluminum Note: See envelope dimensions section Weather resistant Epoxy sealed electronics
CONNECTORS	MIL-C-5015 cylindrical connectors Gold Plated Contacts Conductive anticorrosive coating 9150P 10 pin screw

ENVIRONMENTAL

OPERATING TEMPERATURE	-20°C to 60°C
VIBRATION	5G's 0-100Hz any axis
MOISTURE	MIL STD 810D Method 506 95% Humidity at 60° Soak

TOPCON Positioning Systems, Inc.

7400 National Drive • Livermore, CA • 94551 (925) 245-8300 • FAX (925) 245-8583

© Copyright 2005 Topcon Positioning Systems Inc.

Specifications subject to change without notice



SYSTEM FOUR PLUS SLOPE SENSOR 9150P/9152P

Doc. #7011-0105 Rev. B ECO #2472

SERVICE PARTS

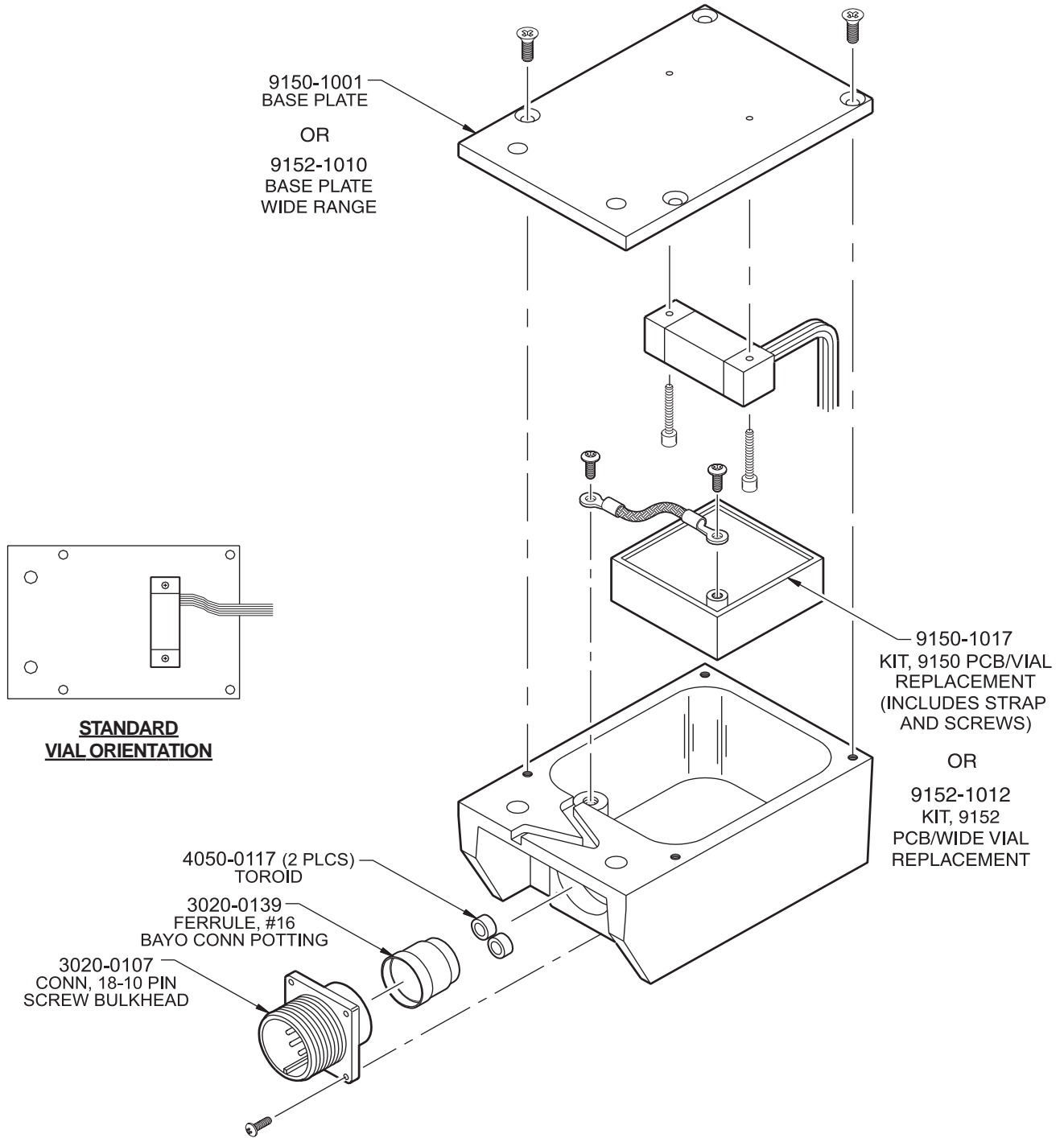

TOPCON Positioning Systems, Inc.

7400 National Drive • Livermore, CA • 94551 (925) 245-8300 • FAX (925) 245-8583

© Copyright 2005 Topcon Positioning Systems Inc.

Specifications subject to change without notice



SYSTEM FOUR PLUS SLOPE SENSOR 9150P/9152P

Doc. #7011-0105 Rev. B ECO #2472

CONNECTOR PINOUTS

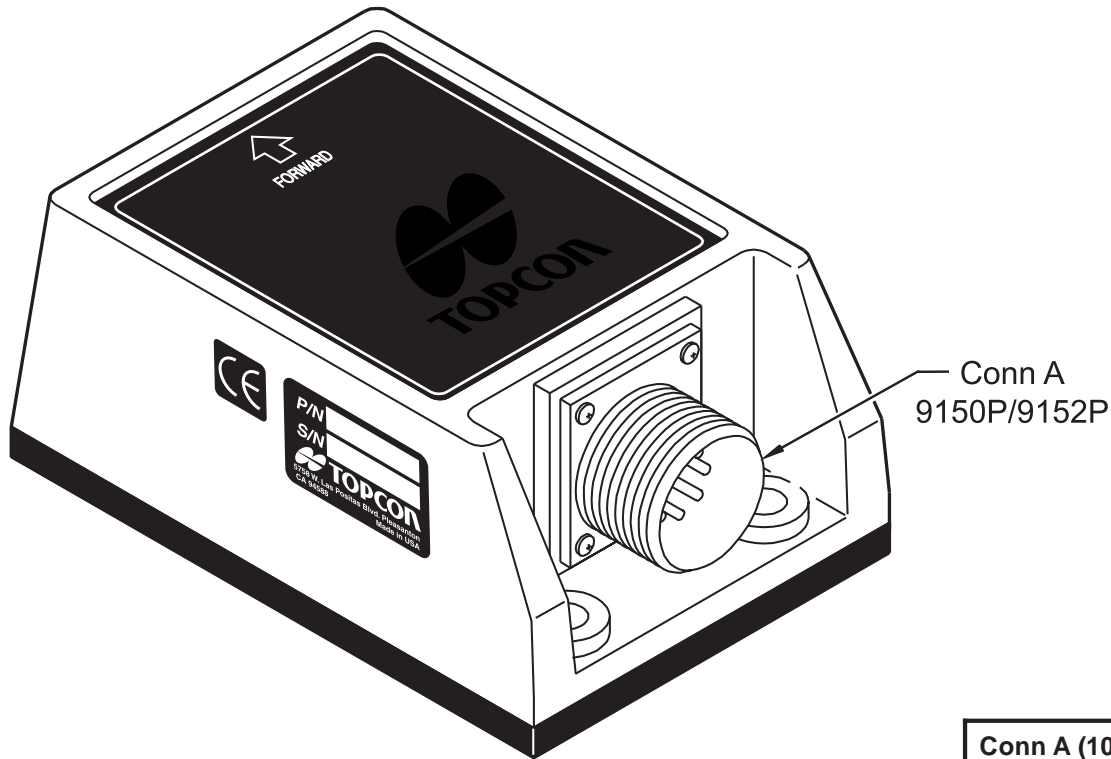

Conn A (10 Pin Screw)	
A	Comm A
B	Comm B
C	V Batt
D	Ground
E	
F	Analog Ref
G	Rotate/Analog In
H	
I	
J	

TOPCON Positioning Systems, Inc.

7400 National Drive • Livermore, CA • 94551 (925) 245-8300 • FAX (925) 245-8583

© Copyright 2005 Topcon Positioning Systems Inc.

Specifications subject to change without notice



SYSTEM FOUR PLUS SLOPE SENSOR 9150P/9152P

Doc. #7011-0105 Rev. B ECO #2472

ENVELOPE DIMENSIONS

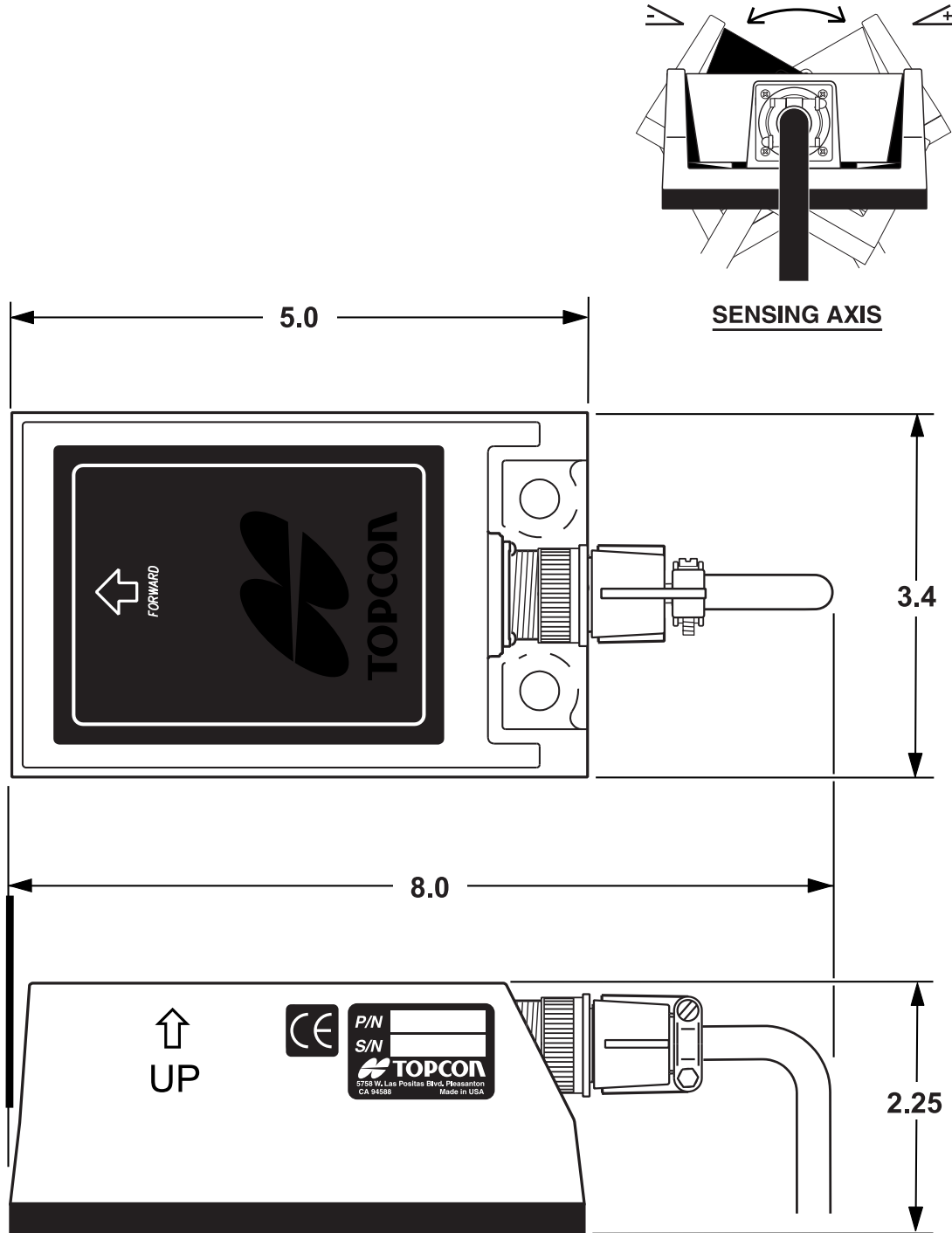

TOPCON Positioning Systems, Inc.

7400 National Drive • Livermore, CA • 94551 (925) 245-8300 • FAX (925) 245-8583

© Copyright 2005 Topcon Positioning Systems Inc.

Specifications subject to change without notice