



## **SA-2793 USER GUIDE**

**BR LEE**

**8515/8816 PAVER**

**AUTOMOTIVE CONTROLLER**

## Table of Contents

---

|             |  |           |
|-------------|--|-----------|
| <b>I.</b>   | <b>Revisions.....</b>                  | <b>2</b>  |
| <b>II.</b>  | <b>Software Specification.....</b>     | <b>2</b>  |
| <b>III.</b> | <b>Description of Operation.....</b>   | <b>3</b>  |
| <b>IV.</b>  | <b>Fault Codes for Status LED.....</b> | <b>8</b>  |
| <b>V.</b>   | <b>I/O Table PLUS 1, MC050.....</b>    | <b>9</b>  |
| <b>VI.</b>  | <b>Service Tool Screens.....</b>       | <b>10</b> |

### I. Revisions

| LEVEL | DESCRIPTION – ECO NUMBER  | DATE    | BY  |
|-------|---|---------|-----|
| 0     | CREATED   | 2/7/06  | ADP |
| 1     | NEUTRAL TIME-OUT VALUE INCREASED ECO#6900                                       | 2/27/06 | ADP |
| 2     | Switch between Sauer high current pump or Rexroth high current pump. ECO # 7227 | 7/25/06 | ADP |

### II. Software Specification

| Module   | NODE # | HWD Version  | Baud Rate | Program Number |
|----------|--------|--------------|-----------|----------------|
| 10100900 | 1      | 10101468v190 | 250K      | SA2793116      |

### III. Description of Operation

#### *Startup*

When the key is turned on the status light will come on for approximately 3 second while the Plus One powers up. The status light will turn off when the machine is ready to start. If the light stays on this means that the joystick(s) in the control box are not in neutral and the Plus One will not allow the engine to start. Placing the joystick(s) in neutral will turn off this light and allow the engine to start. If the light starts to blink see the Fault Code table in section IV of this manual.

#### *Optimization*

After installing this software the steering control box(s) will require optimization as well as calibration (which will be discussed in the next section).

The software will automatically recognize which type of steering control (Dual Joystick or Steering Wheel with Forward/Neutral/Reverse Joystick) is installed and if there is one or two boxes connected. On machines with two boxes; the Plus One will only operate if both boxes are of the same type.

Plus One will not allow the Engine Enable to come on until the Optimization procedure has been done.

**Note:** If the pumps are the high current (Sauer H1 or Rexroth) perform the pump selection.

#### *Pump Control Outputs*

The Plus One controller is setup to operate dual hydrostatic pumps, three options are built in; the low current outputs for the Sauer 42 series pumps(default setting), high current outputs for the Sauer H1 series pumps and high current output for Rexroth pumps.

If the H1 pumps are used you must switch the Plus One to high current outputs

**To set for high current output:** Turn the machine off. Open the dash board panel and locate the Hi Output connector and plug it into the Hi Output receptacle.

#### *Pump Selection (High Current Pumps only):*

The adjustment of the pump parameters in the PLUS1 controller is to handle the different resistance levels in the two High Current pumps; a Sauer H1 and a Rexroth. This is only done for the High Current pumps; the low current (M4200) pump logic requires no changes. The Maximum PWM, Minimum PWM and Threshold Percentage values for High Current outputs all have to be adjusted to accommodate the valves on the Rexroth pump which have approximately thirty-three percent more resistance than the valves on the H1 pump. The default PLUS1 controller values are for a Sauer H1 pump. The following routine handles the selection of parameters:

1. Turn OFF power to the control system (Key in Stop/Off position)
2. Connect at least one Steering Wheel or Dual Joystick control box
3. Turn all RUN / STOP switches on the control box(or boxes) to STOP
4. Open the control panel and install the Y-adapter that allows connecting the Optimize and Calibrate plugs at the same time
5. Connect the High Current plug to the High Current connection
6. Connect the Optimize plug to the Y-adapter (ensure that the wires In and Out match)
7. Connect the Calibrate plug to the Y-adapter (ensure that the wires In and Out match)
8. Turn ON the power to the control system (Key in ON position)
9. Wait for the Status Light on the control panel to go out (indicates waiting for commands / running OK)
10. Move the Left Joystick on either Dual Joystick box (if more than one is installed) or the Speed/Direction Joystick on either Steering Box (if more than one is installed) to one of the following positions to choose which parameters to load:
  - a. All the way Forward – loads the Sauer H1 parameters
  - b. All the way Reverse – loads the Rexroth parameters

11. If both Left Joysticks (Dual Joystick boxes) or both Speed/Direction Joysticks (Steering boxes) are moved then NO parameters will be changed; user can only move one Left Joystick or Speed/Direction Joystick
12. Toggle the RUN / STOP switch on the box with the positioned Left Joystick (or Speed/Direction Joystick) to RUN
13. If Parameter Change is successful, the Status Light will flash very rapidly
14. Toggle the RUN / STOP switch used in step 12 to STOP (the Status Light will stop flashing)
15. Turn OFF the power to the control system (Key in OFF position)
16. Disconnect the Optimize and Calibrate plugs from the Y-adapter

After a Parameter Change routine is completed, all Optimize and Calibrate values are reset to default values. Optimize and Calibrate routines will have to be processed again if they were already done before the Parameter Change.

**To optimize the Dual Joystick Steering Control Box:**

1. Turn the machine off. Open the dash board panel and locate the Optimize/Calibrate connector and plug it into the Optimize receptacle.
2. Place all joysticks in the center position and move the Run/Stop switch(s) into the Stop position.
3. Turn the power key to the on position (power to the Plus One controller). Outputs are disabled. The status light will blink a slow continuous blink to indicate Optimize Mode.
4. Wait 5 seconds for the Plus One to capture the joysticks in center position.
5. Push joysticks full forward for 5 seconds.
6. Push joysticks full reverse for 5 seconds.
7. If a second control box is present optimize it in the same manner.
8. The status light will stop blinking. Unplug the Optimize/Calibrate connector from the Optimize receptacle and turn off the power key.

**To Optimize the Steering Wheel with Forward/Neutral/Reverse Joystick Control Box:**

1. Turn the machine off. Open the dash board panel and locate the Optimize/Calibrate connector and plug it into the Optimize receptacle.
2. Place all steering wheels and joysticks in the center position and move the Run/Stop switch(s) into the Stop position. **Be sure that the steering wheels are centered!**
3. Turn the power key to the on position (power to the Plus One controller). Outputs are disabled. The status light will blink slowly with no pauses to indicate Optimize Mode.
4. Wait 5 seconds for the Plus One to capture the steering wheel center position.
5. Turn the steering wheel full right and push the FNR joystick full forward for 5 seconds.
6. Turn the steering wheel full left and the FNR joystick full reverse for 5 seconds.
7. If a second control box is present optimize it in the same manner.
8. The status light will stop blinking. Unplug the Optimize/Calibrate connector from the Optimize receptacle and turn off the power key.

### ***Calibration***

Calibration (also called straight line tracking) involves 4 steps: Threshold, low, mid and high speed setting. There are separate procedure for calibrating machines with Dual Joystick steering control and Steering wheel with FNR Joystick steering control. On machines with two steering control boxes the calibration will only need to be done with one box. **THIS PROCEDURE WILL SET THE MAXIMUM SPEED OF THE MACHINE.**

#### **To Calibrate the Dual Joystick Steering Control Box:**

Turn the machine off. Open the dash board panel and locate the Optimize/Calibrate connector and plug it into the Calibrate receptacle.

Place all joysticks in the center position and move the Run/Stop switch into the Run position. If two control boxes are present place the other Run/Stop switch to the stop position.

Turn machine on and the status light will blink rapidly with no pauses to indicate Calibration Mode.

#### **Setting the threshold:**

1. Start the engine and run at ½ throttle
2. Move left joystick forward until machine begins to move slightly, then toggle run/stop switch from run to stop and back to run. Return joystick to neutral.
3. Move left joystick reverse until machine begins to move slightly, then toggle run/stop switch from run to stop and back to run. Return joystick to neutral
4. Move right joystick forward until machine begins to move slightly, then toggle run/stop switch from run to stop and back to run. Return joystick to neutral.
5. Move right joystick reverse until machine begins to move slightly, then toggle run/stop switch from run to stop and back to run. Return joystick to neutral.

#### **Setting the straight line tracking:**

1. Move joysticks forward until machine begins to move forward slowly, adjust Right Joystick forward or reverse as necessary to make sure machine is traveling straight. Toggle Run/Stop switch from Run to stop and back to run
2. Move Left Joystick to approximately 1/2 joystick position, adjust Right Joystick forward or reverse as necessary to make sure machine is traveling straight. Toggle Run/Stop switch from Run to stop and back to run.
3. Move Left Joystick to full forward, adjust the Right Joystick forward or reverse as necessary to make sure machine is traveling straight. When the machine has achieved full speed, reduce joystick position until the machine slows to the desired maximum speed and then toggle Run/Stop switch from Run to stop and back to run. **NOTE:** This setting determines the machines maximum speed. Any joystick movement beyond this point will have no effect on the machines forward speed.
4. Repeat for reverse.
5. Bring both joysticks to neutral.
6. Keeping power to the Plus One, unplug the Optimize/Calibrate connector from the Calibrate receptacle (this will write the calibration values to memory).
7. Turn off and restart machine. Run machine to verify acceptable operation. Machine will now operate in typical dual joystick mode with speed and direction of each track controlled by the respective joystick.

**Calibration cont.****To Calibrate the Steering Wheel with Forward/Neutral/Reverse Joystick Control Box:**

Turn the machine off. Open the dash board panel and locate the Optimize/Calibrate connector and plug it into the Calibrate receptacle.

Place all steering wheels and joysticks in the center position and move the Run/Stop switch into the Run position. If two control boxes are present place the other Run/Stop switch to the stop position. Turn machine on and the status light will blink rapidly with no pauses to indicate Calibration Mode.

**Setting the threshold:**

1. Start the engine and run at ½ throttle
2. Turn the steering wheel full left; Move FNR joystick forward until machine begins to move slightly, then toggle run/stop switch from run to stop and back to run. Return joystick to neutral.
3. With steering wheel still at full left; Move FNR joystick reverse until machine begins to move slightly, then toggle run/stop switch from run to stop and back to run. Return joystick to neutral
4. Turn the steering wheel full right. Move FNR joystick forward until machine begins to move slightly, then toggle run/stop switch from run to stop and back to run. Return joystick to neutral.
5. With steering wheel still at full right; Move FNR joystick reverse until machine begins to move slightly, then toggle run/stop switch from run to stop and back to run. Return joystick to neutral.

**Setting the straight line tracking:**

1. Move FNR joysticks forward until machine begins to move forward slowly, adjust the steering wheel as necessary to make sure machine is traveling straight. Toggle Run/Stop switch from Run to stop and back to run
2. Move FNR Joystick to approximately 1/2 joystick position, adjust the steering wheel as necessary to make sure machine is traveling straight. Toggle Run/Stop switch from Run to stop and back to run.
3. Move FNR Joystick to full forward. When the machine has achieved full speed, reduce joystick position until the machine slows to the desired maximum speed. Adjust the steering wheel as necessary to make sure machine is traveling straight. Toggle Run/Stop switch from Run to stop and back to run. **NOTE:** This setting determines the machines maximum speed. Any joystick movement beyond this point will have no effect on the machines forward speed.
4. Repeat for reverse.
5. Bring the FNR joystick to neutral and center the steering wheel.
6. Keeping power to the Plus One, unplug the Optimize/Calibrate connector from the Calibrate receptacle (this will write the calibration values to memory).
7. Turn off and restart machine. Run machine to verify acceptable operation.

***Steering/Acceleration and Deceleration***

Steering the machine is done by slowing the left or right track. When a steering wheel with FNR joystick control box is used the steering wheel angle at which counter-rotation starts and the speed limit for counter-rotation are preprogrammed into the PLUS One's memory. This limits the ability to counter-rotate the tracks at high speeds. If the FNR joystick is at 100% forward, as the steering wheel was turned from centered to full right the right track would only slow to 0% forward (at the inflection point) and never counter-rotate. If the FNR joystick is at 50% forward the right track would counter-rotate at 50% reverse (if the speed limit allows it to). You can achieve full counter-rotation at either full left or full right (hard-over) up to the speed limit, at which point the counter-rotating track would decelerate to zero speed (if over the speed limit). The counter-rotating track can never exceed the speed of the forward track. The steering wheel angle of inflection (point at which the controlled track would start to counter-rotate) and the speed limit for allowing counter-rotation can be adjusted with the Service Tool.

Each joystick and steering wheel has been setup with individual profile and ramping to give smooth control.

Ramping for acceleration and deceleration is proportional to the amount of movement of the joystick. This will provide a quicker ramp for direction changes and a slower ramp if the joysticks are moved to neutral. These profiles can be adjusted with the Service Tool.

The steering wheel profile has been setup to give a finer degree of control when the wheel is moved a small amount and more aggressive steering as the wheel is turned more. These profiles can be adjusted with the Service Tool.

The Steering wheel has a center position dead band separate from the joysticks. This dead band is less than that used by the joystick controller and reduces the amount of “play” in the steering wheel. This dead band can be set with the service tool.

#### ***Steering Box Control Selection***

The Plus One will only assign control of the machine to a steering control box if all joysticks are in neutral, the steering wheels are centered and the Run/Stop switches are in the Stop position. The Plus One will assign control to the first box that is switched to the Run position.

If at anytime the Run/Stop switch is set to the Stop position the machine will decelerate to stop and set the brake after 3 seconds. At anytime during operation if the Run/Stop switch on the second control box is set to the Run position the machine will decelerate to stop and set the brake after 3 seconds. Control will be restored to the operator when this switch is set back to Stop (the machine will ramp back to the setting of the operator’s controls). This purpose of this is to allow personnel on the opposite side of the machine to pause the machine and then return control to the operator by flipping the Run/Stop switch back to Stop.

Machine control can be switched to the second steering control box by setting all joysticks in neutral, centering the steering wheels, switching both Run/Stop switches to the Stop position and then switching the second box to Run.

#### ***Neutral Safety Lockout***

This is an option built into the Plus One program.

If at anytime the machine is in Neutral with the Run/Stop switch in the Run position, the Plus One will disable the control box after a set period of time. The operator will be required to switch from Run to Stop and back to Run to regain control. This is provided as a safety in the event that the operator leaves his station with the control box still active. When activated the machine will not if the joysticks were accidentally moved without someone at the controls. The length of time until lockout activates can be adjusted with the Service Tool. The default is set at 30 Minutes.

#### ***Vibrator/Electric Actuator Relay and Backup Alarm Outputs***

Anytime one or more joysticks are in the forward position (none can be in reverse) the Vibrator/Electric Actuator Relay +12VDC output is turned on. The output is disabled in a counter-rotate condition.

Anytime a joystick is in the reverse position or a counter-rotate condition exists, the Backup Alarm +12VDC output is turned on.

#### ***Brake Release/Pump Neutral Bypass Valve***

This +12VDC output is turned on when any joystick is not in neutral and the Run/Stop switch is in the Run position. The output is turned off when the joysticks are brought to neutral, the operators Run/Stop switched is switched to Stop or the opposite control box is set to Run. There is a proportional time delay, based on output to the pump coils. The maximum delay is 10 seconds if full outputs to the pumps were present and the minimum delay is 3 seconds. The time delay will start when the joysticks are brought to neutral, the operators Run/Stop switched is switched to Stop or the opposite control box is set to Run.

When the run signal is returned the output is immediately turned on and there is a .2 second delay on outputs to the pump coil. This delay allows time for the brake to release before the propel coils are energized.

***Critical Faults***

The following faults will prevent machine movement:

1. Steering control box not detected.
2. Joysticks not optimized.
3. Pump control coil fault.
4. Brake valve/ Pump neutral bypass coil fault (High current output mode only).
5. Joystick(s) not in Neutral at startup.
6. Joysticks in neutral with Run/Stop switch in Run position safety timeout.

A joystick fault can prevent machine movement if:

- There is only one box present
- The fault happens in the box that has control (Run/Stop switch in Run position)
- The fault occurs when neither box has control

The machine will operate if fault occurs in the box that is not currently in control ( i.e. the left box is operating the machine and the right box has a fault). The fault will disable the machine once the controlling box is put in the Stop position. Disconnecting the faulted box will allow control to be restored to the opposite box.

**IV. Fault Codes for Status LED**  
**(The Status light will also blink the fault codes)**

| <b>Blink Code</b>                | <b>Reason for Fault</b>   | <b>Corrective Action</b>  |
|----------------------------------|---|---|
| Continuous On<br>(at startup)    | Joysticks not in neutral at startup   | Place all joysticks in neutral  |
| Continuous On<br>(while running) | Joysticks in neutral too long with Run/Stop Switch in Run position (safety timeout) | Toggle Run/Stop switch from Run to Stop and back to Run   |
| Continuous rapid blink           | Calibration Mode  | Open dashboard panel and unplug the Optimize/Calibrate plug from the Calibrate receptacle                     |
| Continuous slow blink            | Optimize Mode   | Open dashboard panel and unplug the Optimize/Calibrate plug from the Optimize receptacle                      |
| 21                               | Left Steering Control Box not optimized   | Perform Optimize procedure in Section III   |
| 22 or 27                         | Left Steering Control Box:<br>Left joystick or FNR joystick fault                   | Voltage <100mv or >4900 mv<br>Check wires to Left joystick or FNR joystick                                    |
| 23 or 28                         | Left Steering Control Box:<br>Right joystick or steering wheel fault                | Voltage <100mv or >4900 mv<br>Check wires to right joystick or steering wheel                                 |
| 24                               | Right Steering Control Box not optimized  | Perform Optimize procedure in Section III   |
| 25 or 37                         | Right Steering Control Box:<br>Left joystick or FNR joystick fault                  | Voltage <100mv or >4900 mv<br>Check wires to Left joystick or FNR joystick                                    |
| 26 or 38                         | Right Steering Control Box:<br>Right joystick or steering wheel fault               | Voltage <100mv or >4900 mv<br>Check wires to right joystick or steering wheel                                 |
| 31                               | Break Release / Pump neutral bypass valve coil                                      | *Only used in high current output mode*<br>The output is open or short circuited<br>Check the coil and wires. |
| 32                               | Right pump FWD or REV output fault  | The output is open or short circuited<br>Check the coil and wires.  |
| 33                               | Left pump FWD or REV output fault   | The output is open or short circuited<br>Check the coil and wires.  |
| 36                               | Vibrator/ Electric Actuator relay fault   | The output is open or short circuited<br>Check the relay and wires.   |

## V. I/O Table MC050



## MC050-010-00000 PLUS 1™ Controller

## Dimensions and Pin Assignment

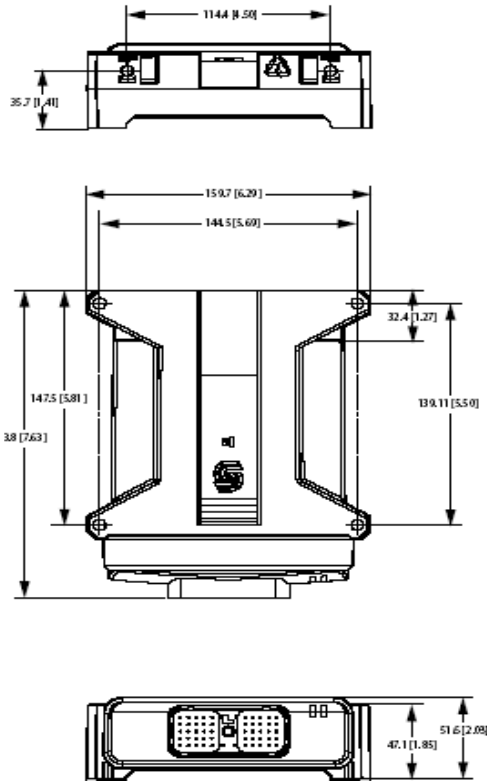

2197

MC050-010-00000 mounting dimensions.

|                       |        |
|-----------------------|--------|
| Power ground -        | C1-P1  |
| Power supply +        | C1-P2  |
| CAN1 +                | C1-P3  |
| CAN1 -                | C1-P4  |
| AIN/CAN1 shield       | C1-P5  |
| DIN                   | C1-P6  |
| DIN                   | C1-P7  |
| 5 V DC sensor power + | C1-P8  |
| Sensor power ground - | C1-P9  |
| DIN                   | C1-P10 |
| DIN                   | C1-P11 |
| DIN                   | C1-P12 |
| DIN                   | C1-P13 |
| DIN/AIN               | C1-P14 |
| DIN/AIN               | C1-P15 |
| DIN/AIN               | C1-P16 |
| DIN/AIN               | C1-P17 |
| DIN/AIN/FreqN         | C1-P18 |
| DIN/AIN/FreqN         | C1-P19 |
| CAN2 +                | C1-P20 |
| CAN2 -                | C1-P21 |
| AIN/CAN2 shield       | C1-P22 |
| DIN/AIN/FreqN         | C1-P23 |
| DIN/AIN/FreqN         | C1-P24 |
| DIN/AIN/FreqN         | C1-P25 |

|                      |        |
|----------------------|--------|
| DIN/AIN/FreqN        | C1-P26 |
| AIN/Temp/Rheo        | C1-P27 |
| AIN/Temp/Rheo        | C1-P28 |
| AIN/Temp/Rheo        | C1-P29 |
| AIN/Temp/Rheo        | C1-P30 |
| DOUT                 | C1-P31 |
| DOUT                 | C1-P32 |
| DOUT                 | C1-P33 |
| DOUT/PVE Pwr1        | C1-P34 |
| DOUT/PVE Pwr2        | C1-P35 |
| DOUT/PVE Pwr3        | C1-P36 |
| PWMOUT/DOUT/PVE 1OUT | C1-P37 |
| PWMOUT/DOUT/PVE 1OUT | C1-P38 |
| PWMOUT/DOUT/PVE 1OUT | C1-P39 |
| PWMOUT/DOUT/PVE 1OUT | C1-P40 |
| PWMOUT/DOUT/PVE 2OUT | C1-P41 |
| PWMOUT/DOUT/PVE 2OUT | C1-P42 |
| PWMOUT/DOUT/PVE 2OUT | C1-P43 |
| PWMOUT/DOUT/PVE 2OUT | C1-P44 |
| PWMOUT/DOUT/PVE 3OUT | C1-P45 |
| PWMOUT/DOUT/PVE 3OUT | C1-P46 |
| Power supply +       | C1-P47 |
| Power supply +       | C1-P48 |
| Power supply +       | C1-P49 |
| Power supply +       | C1-P50 |

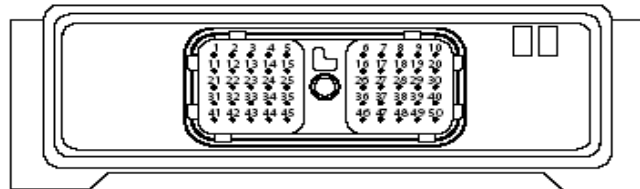

2198

MC050-010-00000 50 pin connector.

Above pinouts are for device pins.  
Use care when wiring mating connector.

## Specifications

| Product Parameters               |                        |
|----------------------------------|------------------------|
| Supply voltage:                  | 9 to 36 V              |
| Operating temperature (ambient): | -40 to 70° C           |
| Storage temperature:             | -40 to 85° C           |
| IP rating:                       | IP 67                  |
| EMI/RFI rating:                  | 100 V/M                |
| Weight:                          | 0.53 kg (1.16 lb)      |
| Vibration:                       | IEC 60068-2-64         |
| Shock:                           | IEC 60068-2-27 test Ea |
| Maximum current:                 | 40 A                   |

| Ordering Information  | Part Number                |
|---|----------------------------|
| MC050-010-00000   | 10100900                   |
| Related Products  | Part Number                |
| USB to CAN communicator   | 1091099                    |
| Deutsch mating connector bag assembly                               | 10100946                   |
| PLUS 1 GUIDE single user license                                    | 10101000                   |
| Comprehensive Technical Information                                 |                            |
| PLUS 1 Controller Family Technical Information manual order number: | DKMH.PB.700.A1.02/520L0719 |
| Product literature is on line at:                                   | www.sauer-danfoss.com      |

© Copyright 2004, Sauer-Danfoss. All rights reserved. Contents subject to change.  
Sauer-Danfoss, Sauer-Danfoss logo type and PLUS 1 are trademarks of the Sauer-Danfoss Group.  
Microsoft and Windows are trademarks of Microsoft Corporation.

DKMH.PD.760.G1.02/520L0714 01/2004

VI. Service Tool

Main Screen

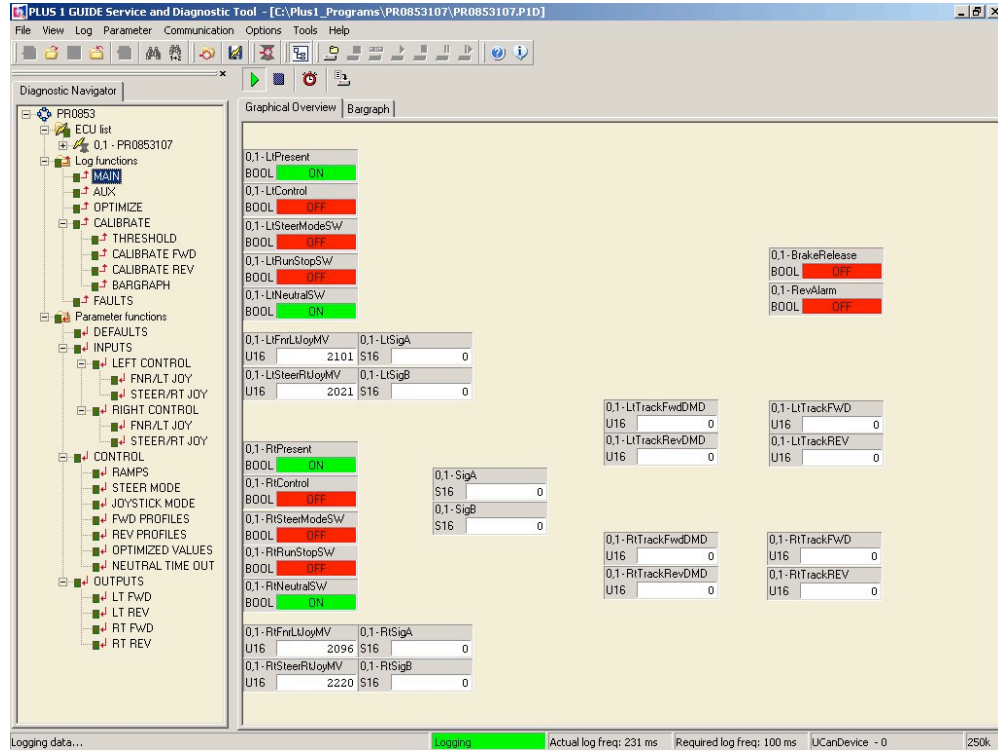

Aux Screen

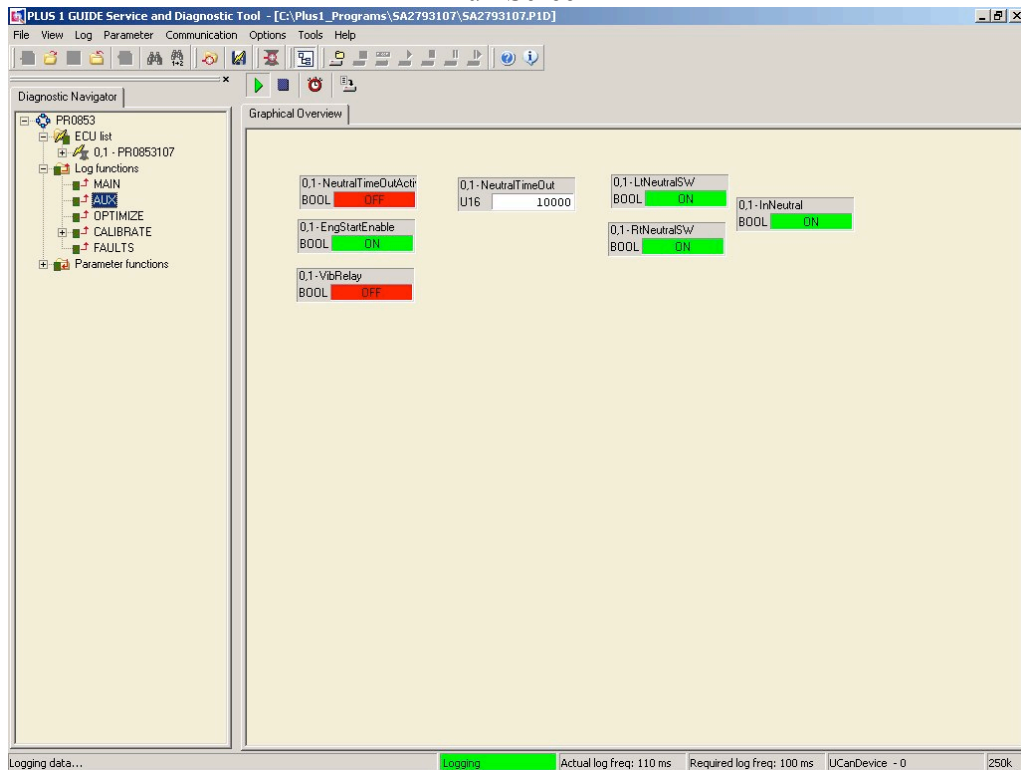

### Optimize Screen

PLUS 1 GUIDE Service and Diagnostic Tool - [C:\Plus1\_Programs\SA2793108\SA2793108.P1D]

File View Log Parameter Communication Options Tools Help

Diagnostic Navigator

- PR0853
  - ECU list
    - 0,1 - PR0853108
      - Log functions
        - MAIN
        - AUX
        - OPTIMIZE**
        - CALIBRATE
        - FAULTS
      - Parameter functions
        - DEFAULTS
        - INPUTS
          - LEFT CONTROL
            - FNR/LT JOY
            - STEER/RT JOY
          - RIGHT CONTROL
            - FNR/LT JOY
            - STEER/RT JOY
        - CONTROL
          - RAMPS
          - STEER MODE
          - JOYSTICK MODE
          - FWD PROFILES
          - REV PROFILES
          - OPTIMIZED VALUES
          - NEUTRAL TIME OUT
        - OUTPUTS
          - LT FwD
          - LT REV
          - RT FwD
          - RT REV

Graphical Overview

|                                 |                                 |                                 |                                 |                               |  |
|---------------------------------|---------------------------------|---------------------------------|---------------------------------|-------------------------------|--|
| 0,1 - OptimizeSW<br>BD0L OFF    | 0,1 - OptimizeMode<br>BD0L OFF  |                                 |                                 |                               |  |
| 0,1 - LIFnrLTJoyMV<br>U16 43    | 0,1 - LIFnrLTJoyMV<br>U16 43    | 0,1 - LISigA MaxCal<br>U16 4444 | 0,1 - LISigB MaxCal<br>U16 4469 |                               |  |
| 0,1 - LISigA MinCal<br>U16 500  | 0,1 - LISigA CenCal<br>U16 2519 | 0,1 - LISigB CenCal<br>U16 2549 | 0,1 - LISigB MinCal<br>U16 481  | 0,1 - LSteerCenDB<br>S16 1000 |  |
| 0,1 - LISigA NotCal<br>BD0L OFF | 0,1 - LISigB NotCal<br>BD0L ON  | 0,1 - LISigA MaxCal<br>U16 0    | 0,1 - LISigB MaxCal<br>U16 0    |                               |  |
| 0,1 - LISigA CenCal<br>U16 0    | 0,1 - LISigB CenCal<br>U16 0    | 0,1 - LISigA MinCal<br>U16 0    | 0,1 - LISigB MinCal<br>U16 0    | 0,1 - RSteerCenDB<br>S16 1000 |  |

Logging data... Logging Actual log freq: 195 ms Required log freq: 100 ms UCanDevice - 0 250K

### Calibrate Threshold Screen

PLUS 1 GUIDE Service and Diagnostic Tool - [C:\Plus1\_Programs\PR0853107\PR0853107.P1D]

File View Log Parameter Communication Options Tools Help

Diagnostic Navigator

- PR0853
  - ECU list
    - 0,1 - PR0853107
      - Log functions
        - MAIN
        - AUX
        - OPTIMIZE
        - CALIBRATE**
          - THRESHOLD**
          - CALIBRATE FwD
          - CALIBRATE REV
          - BARGRAPH
        - FAULTS
      - Parameter functions
        - DEFAULTS
        - INPUTS
          - LEFT CONTROL
            - FNR/LT JOY
            - STEER/RT JOY
          - RIGHT CONTROL
            - FNR/LT JOY
            - STEER/RT JOY
        - CONTROL
          - RAMPS
          - STEER MODE
          - JOYSTICK MODE
          - FWD PROFILES
          - REV PROFILES
          - OPTIMIZED VALUES
          - NEUTRAL TIME OUT
        - OUTPUTS
          - LT FwD
          - LT REV
          - RT FwD
          - RT REV

Graphical Overview

|                       |                        |                       |
|-----------------------|------------------------|-----------------------|
| 0,1 - LISigA<br>S16 0 | 0,1 - MIN1<br>U16 1848 | 0,1 - RISigA<br>S16 0 |
|                       | 0,1 - MIN2<br>U16 2463 |                       |
| 0,1 - LISigB<br>S16 0 | 0,1 - MIN3<br>U16 2500 | 0,1 - RISigB<br>S16 0 |
|                       | 0,1 - MIN4<br>U16 2345 |                       |

Logging data... Logging Actual log freq: 109 ms Required log freq: 100 ms UCanDevice - 0 250K

### Calibrate Fwd Screen

PLUS 1 GUIDE Service and Diagnostic Tool - [C:\Plus1\_Programs\PR0853107\PR0853107.P1D]

File View Log Parameter Communication Options Tools Help

Diagnostic Navigator

- PR0853
  - ECU list
    - 0.1 - PR0853107
      - Log functions
        - MAIN
        - AUX
        - OPTIMIZE
        - CALIBRATE
          - THRESHOLD
          - CALIBRATE FWD**
          - CALIBRATE REV
          - BARGRAPH
          - FAULTS
        - Parameter functions

Graphical Overview

0.1-CalModeSW U1-CalMode  
 BOOL OFF OOL OFF

|                        |                       |                         |
|------------------------|-----------------------|-------------------------|
| 0.1-LiFwdY6<br>U16 739 | 0.1-FwdK6<br>U16 1000 | 0.1-RiFwdY6<br>U16 1000 |
| 0.1-LiFwdY5<br>U16 354 | 0.1-FwdK5<br>U16 743  | 0.1-RiFwdY5<br>U16 743  |
| 0.1-LiFwdY4<br>U16 56  | 0.1-FwdK4<br>U16 191  | 0.1-RiFwdY4<br>U16 191  |
| 0.1-LiFwdY3<br>U16 56  | 0.1-FwdK3<br>U16 191  | 0.1-RiFwdY3<br>U16 191  |
| 0.1-LiFwdY2<br>U16 56  | 0.1-FwdK2<br>U16 191  | 0.1-RiFwdY2<br>U16 191  |

|                            |                            |
|----------------------------|----------------------------|
| 0.1-LiTrackFwdDMD<br>U16 0 | 0.1-RTTrackFwdDMD<br>U16 0 |
| 0.1-SigA<br>S16 0          | 0.1-SigB<br>S16 0          |

Logging data... Logging Actual log freq: 174 ms Required log freq: 100 ms UCanDevice - 0 250k

### Calibrate Rev Screen

PLUS 1 GUIDE Service and Diagnostic Tool - [C:\Plus1\_Programs\PR0853107\PR0853107.P1D]

File View Log Parameter Communication Options Tools Help

Diagnostic Navigator

- PR0853
  - ECU list
    - 0.1 - PR0853107
      - Log functions
        - MAIN
        - AUX
        - OPTIMIZE
        - CALIBRATE
          - THRESHOLD
          - CALIBRATE FWD
          - CALIBRATE REV**
          - BARGRAPH
          - FAULTS
        - Parameter functions

Graphical Overview

0.1-CalModeSW 1-CalMode  
 BOOL OFF OOL OFF

|                        |                      |                        |
|------------------------|----------------------|------------------------|
| 0.1-LiRevY6<br>U16 985 | 0.1-RevX6<br>U16 985 | 0.1-RiRevY6<br>U16 937 |
| 0.1-LiRevY5<br>U16 719 | 0.1-RevX5<br>U16 719 | 0.1-RiRevY5<br>U16 498 |
| 0.1-LiRevY4<br>U16 17  | 0.1-RevX4<br>U16 208 | 0.1-RiRevY4<br>U16 208 |
| 0.1-LiRevY3<br>U16 17  | 0.1-RevX3<br>U16 208 | 0.1-RiRevY3<br>U16 208 |
| 0.1-LiRevY2<br>U16 17  | 0.1-RevX2<br>U16 208 | 0.1-RiRevY2<br>U16 208 |

|                            |                            |
|----------------------------|----------------------------|
| 0.1-LiTrackRevDMD<br>U16 0 | 0.1-RTTrackRevDMD<br>U16 0 |
| 0.1-SigA<br>S16 0          | 0.1-SigB<br>S16 0          |

Logging data... Logging Actual log freq: 187 ms Required log freq: 100 ms UCanDevice - 0 250k



### Inputs Steer/RT Joy Screen

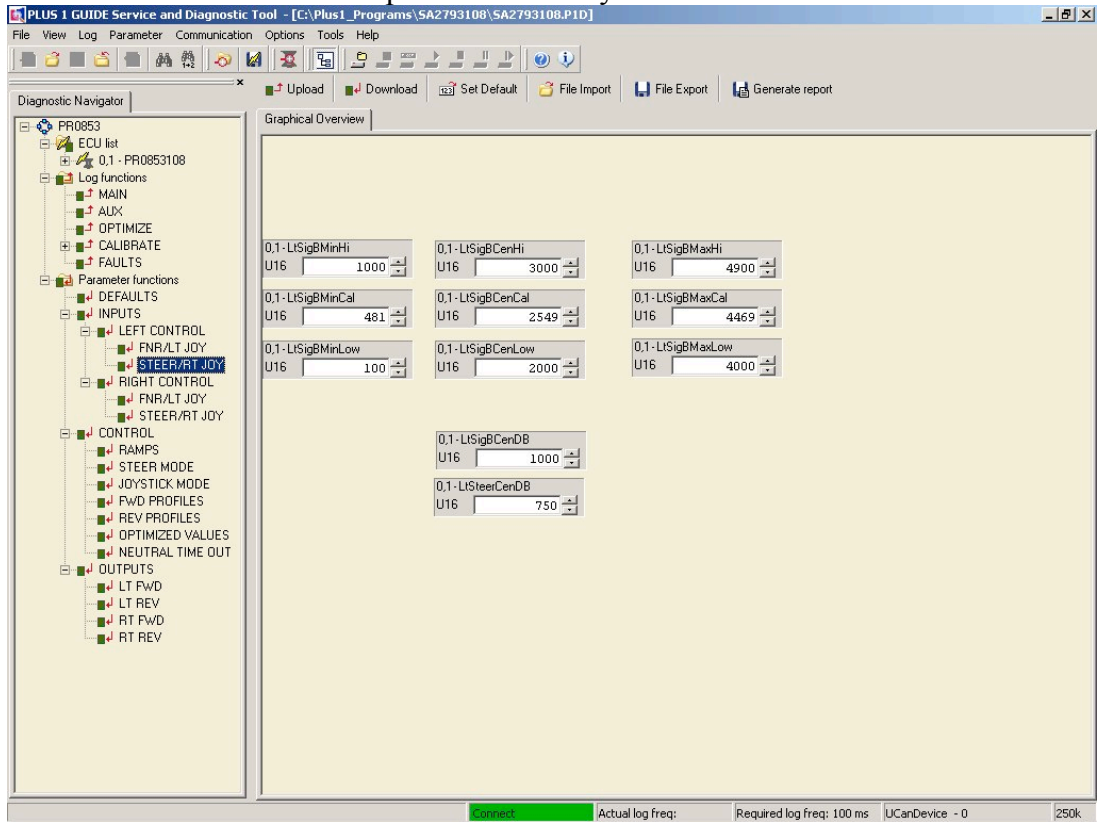

### Control Ramps Screen

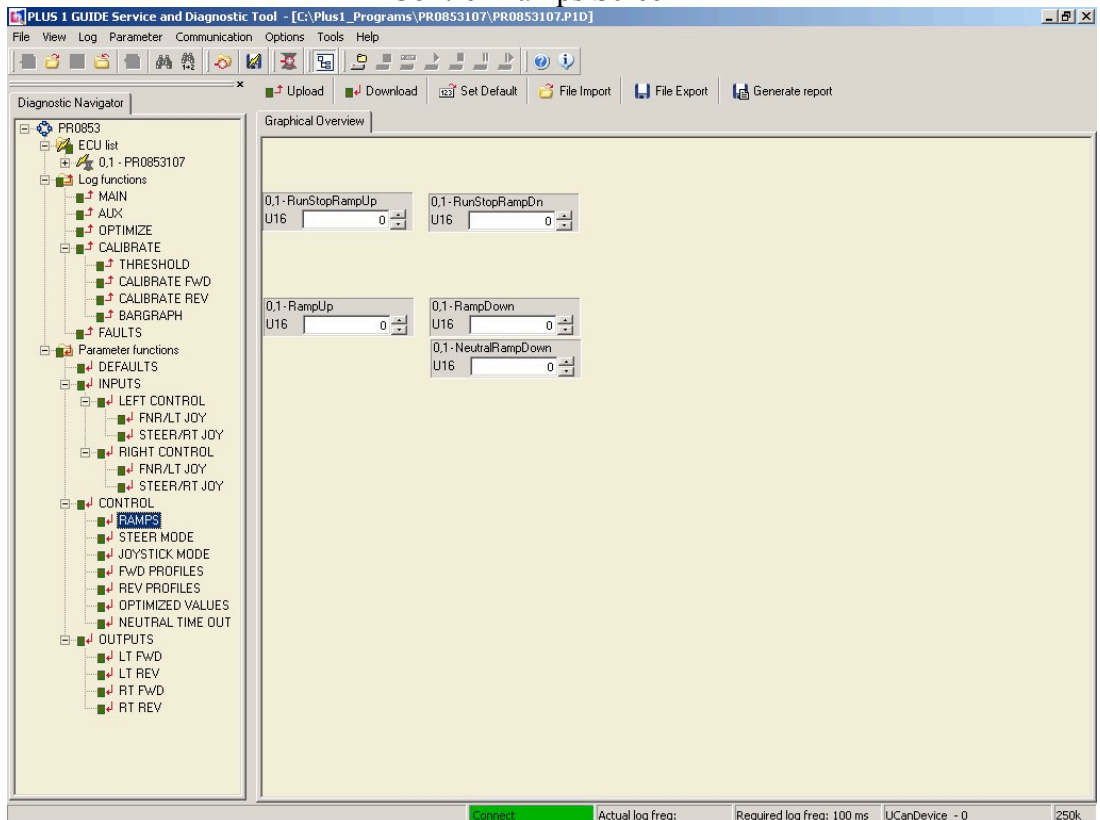

### Control Steer Mode Screen

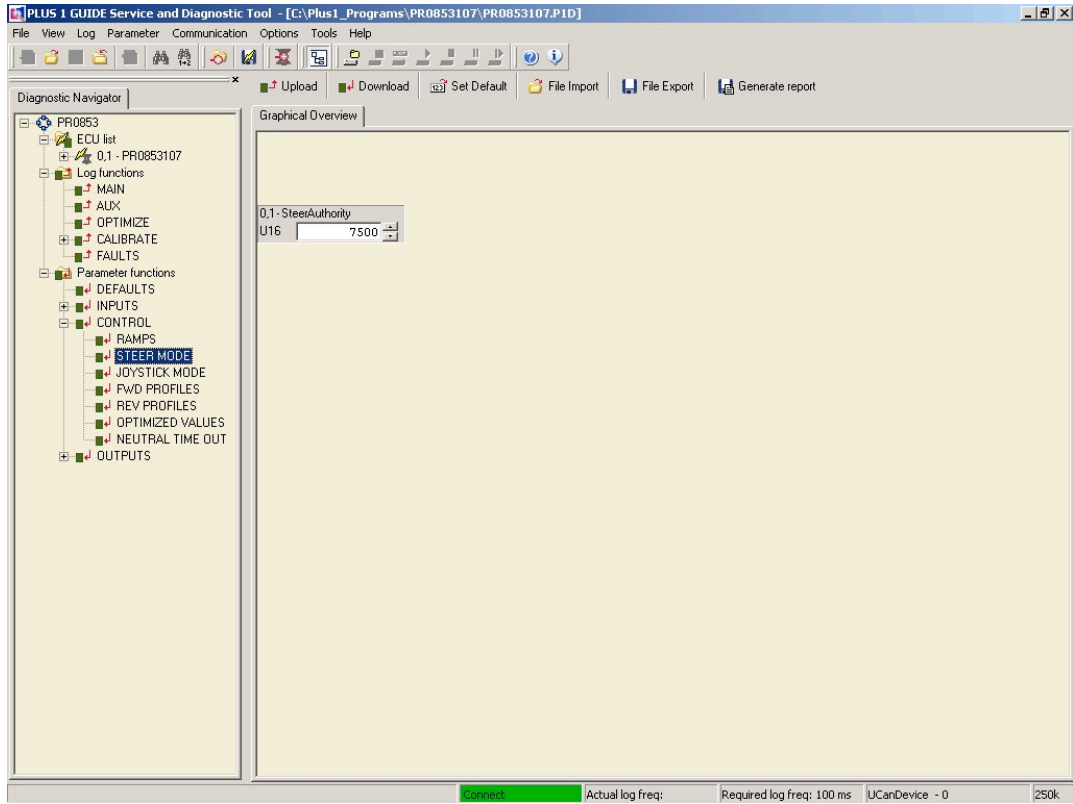

### Control FWD Profiles Screen

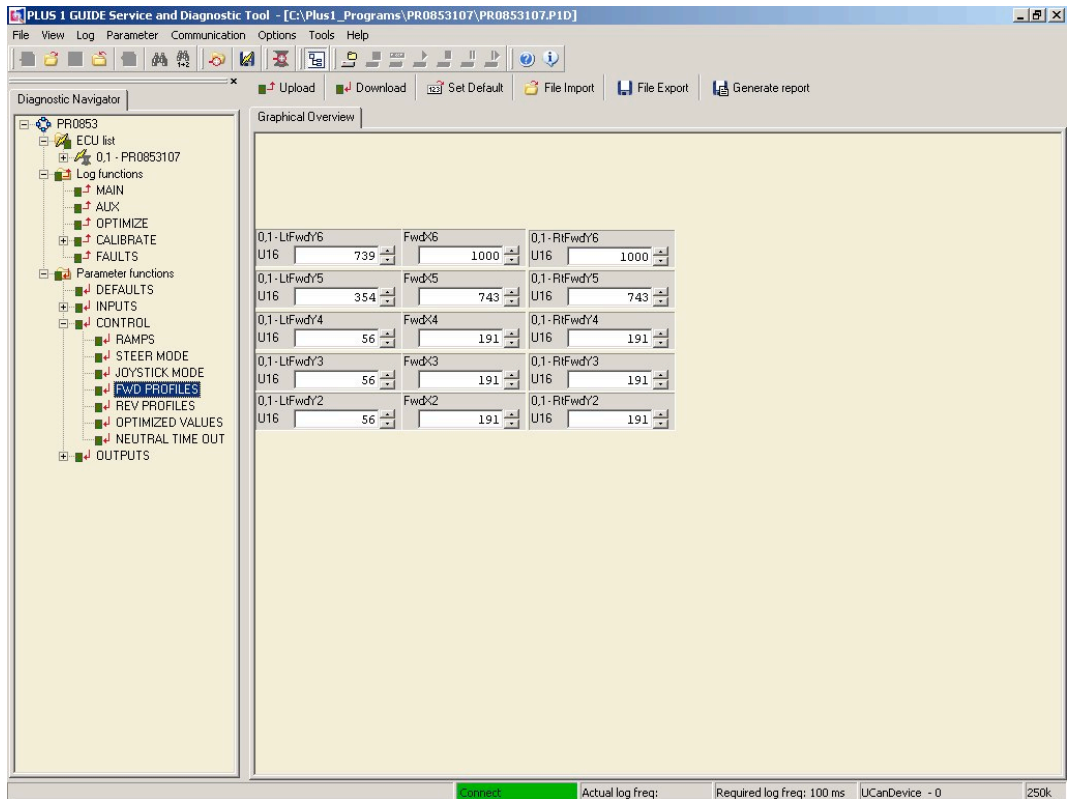

### Control REV Profiles Screen

PLUS 1 GUIDE Service and Diagnostic Tool - [C:\Plus1\_Programs\PR0853107\PR0853107.P1D]

File View Log Parameter Communication Options Tools Help

Upload Download Set Default File Import File Export Generate report

Diagnostic Navigator

- PR0853
  - ECU list
    - 0.1 - PR0853107
      - Log functions
        - MAIN
        - AUX
        - OPTIMIZE
        - CALIBRATE
        - FAULTS
      - Parameter functions
        - DEFAULTS
        - INPUTS
        - CONTROL
          - RAMPS
          - STEER MODE
          - JOYSTICK MODE
          - FWD PROFILES
          - REV PROFILES**
          - OPTIMIZED VALUES
          - NEUTRAL TIME OUT
        - OUTPUTS

Graphical Overview

|                     |     |   |     |                     |     |
|---------------------|-----|---|-----|---------------------|-----|
| 0.1- LIRevY6<br>U16 | 985 | 6 | 985 | 0.1- RiRevY6<br>U16 | 937 |
| 0.1- LIRevY5<br>U16 | 719 | 6 | 719 | 0.1- RiRevY5<br>U16 | 498 |
| 0.1- LIRevY4<br>U16 | 17  | 6 | 208 | 0.1- RiRevY4<br>U16 | 208 |
| 0.1- LIRevY3<br>U16 | 17  | 6 | 208 | 0.1- RiRevY3<br>U16 | 208 |
| 0.1- LIRevY2<br>U16 | 17  | 6 | 208 | 0.1- RiRevY2<br>U16 | 208 |

Connect Actual log freq: Required log freq: 100 ms UCanDevice - 0 250k

### Control Optimized Values Screen

PLUS 1 GUIDE Service and Diagnostic Tool - [C:\Plus1\_Programs\PR0853107\PR0853107.P1D]

File View Log Parameter Communication Options Tools Help

Upload Download Set Default File Import File Export Generate report

Diagnostic Navigator

- PR0853
  - ECU list
    - 0.1 - PR0853107
      - Log functions
        - MAIN
        - AUX
        - OPTIMIZE
        - CALIBRATE
        - FAULTS
      - Parameter functions
        - DEFAULTS
        - INPUTS
        - CONTROL
          - RAMPS
          - STEER MODE
          - JOYSTICK MODE
          - FWD PROFILES
          - REV PROFILES
          - OPTIMIZED VALUES**
          - NEUTRAL TIME OUT
        - OUTPUTS

Graphical Overview

|                  |      |
|------------------|------|
| 0.1- MIN1<br>U16 | 1848 |
| 0.1- MIN2<br>U16 | 2463 |
| 0.1- MIN3<br>U16 | 2500 |
| 0.1- MIN4<br>U16 | 2345 |

Connect Actual log freq: Required log freq: 100 ms UCanDevice - 0 250k

### Neutral Time Out Screen

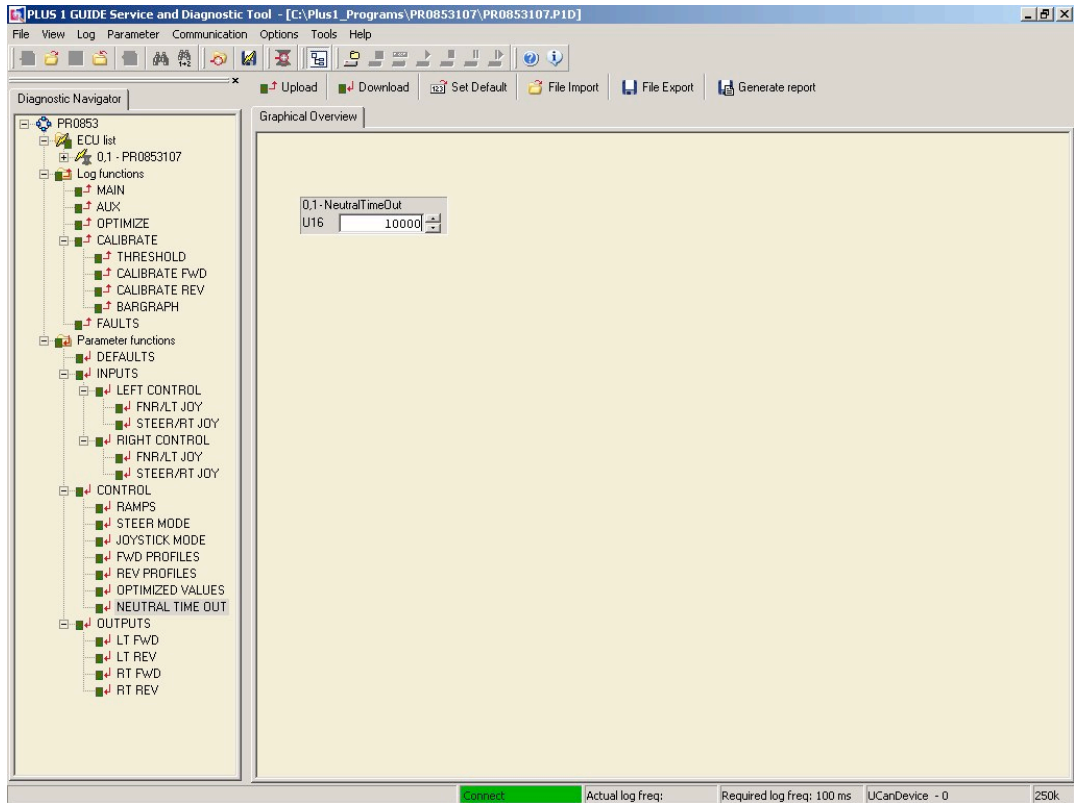

### Outputs LT FWD Screen

