MOBA Mobile Automation AG

**MOBA-MATIC
OPERATOR'S MANUAL**

Version 4.28-005 (01.2003)



TEREX
Roadbuilding

MOBA-matic, CAN Operating instructions -english-

version 4.28-005 and higher



The text and graphics of this manual have been elaborated with the greatest possible care. However, we may not be held liable for possible errors and failure effects.

Should you wish to make suggestions regarding the arrangement of this manual or point out possible errors, please contact your local dealer. We will gladly take up any of your ingenious ideas and suggestions.

Some company and label names are subject to label-, patent- or trade-mark protection.

All rights reserved. This document must not be duplicated or transferred for any purpose whatsoever without MOBA's written consent, irrespective of the way or the means which are used.

Order-no.: 10-02-00855

Date: 01.2003



MOBA
Mobile Automation AG
Vor den Eichen 4
D-65604 Elz
Internet: www.moba.de

Table of Contents:

1. General information	5
1.1 Introduction.....	5
1.2 Packaging and storage	6
1.3 Precautionary measures	7
2. Product description.....	10
3. System summary	11
3.1 Mechanical Components	13
3.2 System Configurations	15
4. The digital controller	18
4.1 Description of the digital controller	18
4.2 Switch on test	22
4.3 Sensor identification	22
4.4 Operator menu.....	23
4.4.2 Sensor selection	26
4.4.4 Sensitivity setting.....	28
4.4.5 Control window setting	31
4.4.6 Unit of distance setting.....	32
4.4.7 Position factor	33
4.4.8 Hydraulic record.....	36
4.4.9 Graphic representation of the operator menu.....	37
4.5 Different user settings	38
5. The Digi-Slope sensor	40
5.1 Description.....	40
5.2 Mounting.....	40
5.3 Operation of the Digi-Slope sensor.....	41
6. The Sonic-Ski sensor.....	44
6.1 Description.....	44
6.2 Mounting instructions and working range.....	44
6.3 Working with the Sonic-Ski sensor	46
7. The Rotary sensor	50
7.1 Description.....	50
7.2 Mounting instructions and possible applications	50
7.3 Working with the Rotary sensor.....	53
8. The Wire Rope sensor (YOYO)	57
8.1 Description.....	57
8.2 Mounting.....	57
8.3 Working with the Wire Rope sensor.....	59
9. The laser receiver LS 250.....	62
9.1 Description.....	62
9.2 Mounting instructions	62
9.3 Working with the laser receiver LS 250	64
10. The Big-Ski.....	67
10.1 Description.....	67
10.4 Set-up.....	71
10.5 Working with the Big-Ski	72
11. Maintenance	75
11.1 General information.....	75
11.2 How to clean the unit.....	75
12. Remedial measures in case of malfunction.....	76

12.1 General information	76
12.2 Fault indications and remedial measures	77
13. Technical data	78
14. Parameter menu	88
14.1 General information	88
14.2 Operator menu	89
14.3 Basic parameter menu	93
15. Controller set up examples.....	106
15.1 Steps to program a controller for a paver	106
15.2 Steps to program a controller for a mill	110
16. Declaration of conformance.....	114

1. General information

1.1 Introduction

This manual contains important information concerning the installation, initiation and operation of the MOBA-matic, as well as tips for maintenance and trouble shooting. Furthermore, you will find a detailed description of all operating elements and their functions.

A description of all interfaces and their configuration is enclosed for the purpose of connection and trouble shooting.

MOBA-matic is available with various sensor combinations. Please always use these operating instructions when working with your MOBA-matic system.

In case that your MOBA-matic system is not equipped with all sensors, please disregard the respective descriptions.

Pictograms and symbols:

The following pictograms and symbols are used in this manual:



Residual risks and sources of danger in the event of improper handling which place the life and limb of operating personnel at risk are marked by a warning triangle with an exclamation mark. This also applies to potential damage to equipment..



Notes which need to be observed are indicated by a hand symbol.



Particularly important notes are printed in bold type.

- Lists are marked by a black dot.
- Operating steps to be performed by operating personnel are indicated by an arrow head.

Subject to change (without notice):

We have taken trouble to keep the information in these operating instructions correct and up to date. To maintain our technical leadership it may be necessary, without notice, to make changes to the product or its operation which, in certain circumstances, do not correspond to these instructions. In this case your MOBA supplier can supply up to date operating instructions. We accept no liability for disturbances, breakdowns or damages caused thereby.

1.2 Packaging and storage

In order to ensure adequate protection during transport, the products have been carefully packed.

On receipt the goods and the packaging should be checked for damage.



In case of damage the equipment must not be operated!

Damaged cables or connectors are also a risk to safety and, likewise, must not be used!

In this case, please contact your MOBA supplier.



If the equipment is not to be used directly after it is unpacked it must be protected from moisture and dirt.

1.3 Precautionary measures



Before mounting, servicing and operating the equipment please read the operating instructions carefully and completely. If questions arise, please contact your MOBA supplier.

Safety measures:

The safety measures recommended here correspond basically to the guidelines for installation and commissioning of electrical systems. They can be used for all applications in conjunction with MOBA equipment.

Mounting:

When mounting the equipment only original MOBA cables may be used. The connectors may not be removed from the cables because they are protected against moisture; removing them will damage the protection. Make sure that the all the screws of the connectors are tight. Additional mounting information for the equipment and sensors can be obtained from the enclosed data sheets or the installation instructions.

Wiring:

The wiring must be carried out correctly and correspond to the information given in these instructions. All supply leads and connecting terminals must be sized for the corresponding current. Further, all connections must be made in accordance with valid VDE regulations or with valid national regulations.

Safety against disturbances:

This equipment has been designed for industrial use and has been tested accordingly. However, microprocessor technology puts certain demands on the installation. We would therefore like to point out the following things about an installation that, if not taken into account, can lead later to disturbances during operation:

- Ensure that the polarity of the connections is correct;
- Supply voltages may not exceed, or fall short of, the specified values;
- Protect the equipment with a suitable supply fuse;
- Use cables suitable for the currents and voltages ;
- Make the cabling paths as short as possible (avoid loops);
- Separate control cables from power cables as far as possible;
- Suppress contactor and relays coils; (diode suppressor connectors)
- The requirement for a disturbance-free operation is a good electrical connection between the machine and the case/chassis of the separate components;
- Connect screened cables to earth at one end only (the equipment end);
- Do not supply other equipment directly from the supply terminals of this equipment;
- Do not use unused terminals as connection points for other equipment;
- Remove all system components, disconnect their power supply before welding;

Maximum Voltages:

Do not exceed the maximum allowed voltages. The maximum voltage between any two isolated circuits, or between one circuit and earth, is, if not otherwise noted, limited to the highest value of the corresponding input voltage or the corresponding supply voltage. The connecting terminals or plug must be equipped with a fuse.

Fuses:

The equipment is designed with electronic fuses for protection against reversed connections, voltage spikes and short term over-voltages. The supply voltages given in the technical data must not be exceeded.

Configuration:

The equipment can be configured by the user. When reconfiguring, the user is obliged to do this only in accordance with the circumstances of the complete system.

Alarm device:

In complex systems, in which a malfunction could lead to danger to the operating personnel or to the system, it is wise to employ an independent alarm device to supervise the process. An independent device offers protection by announcing an alarm and switching off the system. In many cases the use of an alarm in the controller does not, provide adequate protection.

Areas endangered by explosion:

The equipment is **not** for use in areas endangered by explosion.

Clearance of faults:

Before starting to clear faults make sure that every voltage supply to the equipment has been removed. Faulty equipment should be examined in an area suitably set up out for test purposes. Every attempt to correct a fault in equipment that is still installed can be dangerous for personnel and for the system. Before you remove or exchange sensors in the system, make sure that the supply voltages have been removed.

Ask for help:

For questions about the operation or about mounting please contact your MOBA supplier.

Failure to observe the above measures can lead to a failure of the equipment, of the machine or even injury to personnel. Damage or injury, which is traceable to non-observance of the precautionary measures described above, is excluded from the manufacturer's guarantee.

2. Product description

The MOBA-matic is a universal control system for building machines of all types. The extensive range of sensors used for distance- and slope measurement as well as its ease of operation and reliability make MOBA-matic a flexible and efficient control system for pavers, concrete road finishers, mastic asphalt finishers, milling machines, dozers, Kilvar- and built-on graders.

The system is based on modern micro-processor technology and communicates using the "CAN-bus" (**C**ontrolled **A**rea **N**etwork).

This CAN-bus represents the state of the art in electronic vehicle equipment and therefore guarantees maximum system safety. Furthermore, it facilitates the system's central operation and, due to its modular design, its ability for expansion. Due to this, you may fit in new sensors anytime and without any problems, so that the system will always suit the application requirements.









The heart of the system, the digital controller, identifies all connected sensors automatically as soon as the system is switched on.

In addition to this, MOBA-matic can also be connected to a GPS or total station.

3. System summary







Electronics		
COMPONENTS	DESCRIPTION	PART #
	DLS II – V4.28, "Global version" Digital controller with integrated LED indicator, 12pole connector to machine (connecting cables see "equipment")	04-25-10453
	Sonic-Ski Sensor, CAN Multiple-ultrasonic - Grade sensor	04-21-10020
	Dual-Sonic Sensor, CAN Single-ultrasonic sensor with temp. compensation	04-21-10100
	Rotary Sensor, CAN Mechanical Grade Sensor	04-21-40110
	Rotary Sensor, CAN Mechanical Grade Sensor with wand, skate and grid arm	05-21-40110
	LS-250 Proportional Laser Receiver	04-60-11010
	Wire Rope Sensor For Mill applications	04-21-30020
	Slope Sensor, CAN Slope sensor with mounting plate	04-21-21010

Cables and Junction Boxes

COMPONENTS	DESCRIPTION	PART NUMBER
	Coil cable, machine to connect CAN-controller or (Power-CAN-Box)/machine Barber Greene/Servo,CAT Servo, Cedarrapids,Champion,Roadtec,Ingersoll Rand, Gilcrest,Neal,ABG,Bitelli,Marini, Voegele,Dynapac,Demag	04-02-02560
	Coil cable, machine to connect CAN-controller or (Power-CAN-Box)/machine Barber Greene/CAT Proportional	04-02-02562
	Coil cable, machine to connect CAN-controller or (Power-CAN-Box)/machine Blaw Knox Paver	04-02-02563
	Coil cable, to connect CAN-controller/sensors/ junction box to a hard wired CAN-BUS	04-02-02620
	Straight cable, 3 Meter to connect CAN-controller to the slope sensor	04-02-02660
	Straight cable, 1 Meter to connect CAN-controller to the slope sensor	04-02-08008
	Junctionbox for fixed wiring of CAN-Slope and 3-D	04-03-00420
	Junctionbox to connect up to Grade Sensors, CAN	04-03-00415

3.1 Mechanical Components

Brackets and Hardware		
COMPONENTS	DESCRIPTION	PART #
	Bracket for DLS-II Controller System requirements: 2 units	04-05-00610
	Controller Mounting Assembly System requirements: 2 units	04-05-50360
	J-Box Mount System requirements: 2 units for Cedarapids	04-05-50410
	Junction Box Mounting Plate System requirements: 2 units	01-17-50030
	Slope Sensor Mounting Plate System requirements: 1 units	04-05-50040
	Mount, Slope Sensor System requirements: 1 units incl. Cedarapids	04-05-50420
	Pole 24" System requirements: 2 units	01-17-50010

Brackets and Hardware		
COMPONENTS	DESCRIPTION	PART #
	Pole 36" System requirements: 2 units	01-17-50020
	Screed Mount System requirements: 2 units incl. handles	04-05-50030
	Cross over Bracket System requirements: 4 units incl. Handles	04-05-50020
	Mounting Arm, Grade Sensor System requirements: 2 units incl. Handles (For use with 1.9" tubing)	04-05-50430
	Grade sensor Bracket System requirements: 2 units	04-05-50010
	Case - MOBA-matic max. for 2 controller, 3 Sonic-Ski, 2 Digi-Rotary, 1 Slope and equipment	04-06-50000

3.2 System Configurations

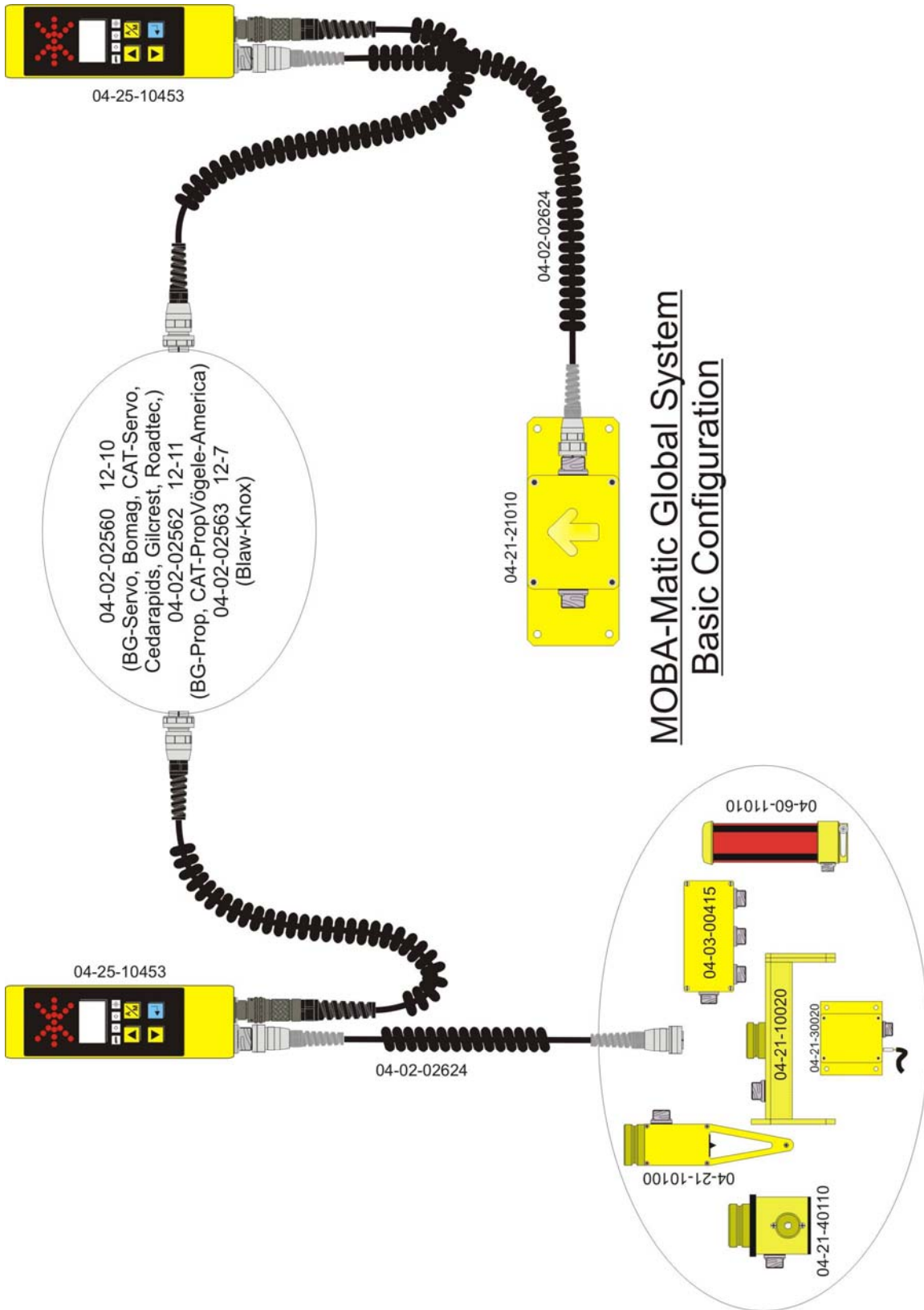

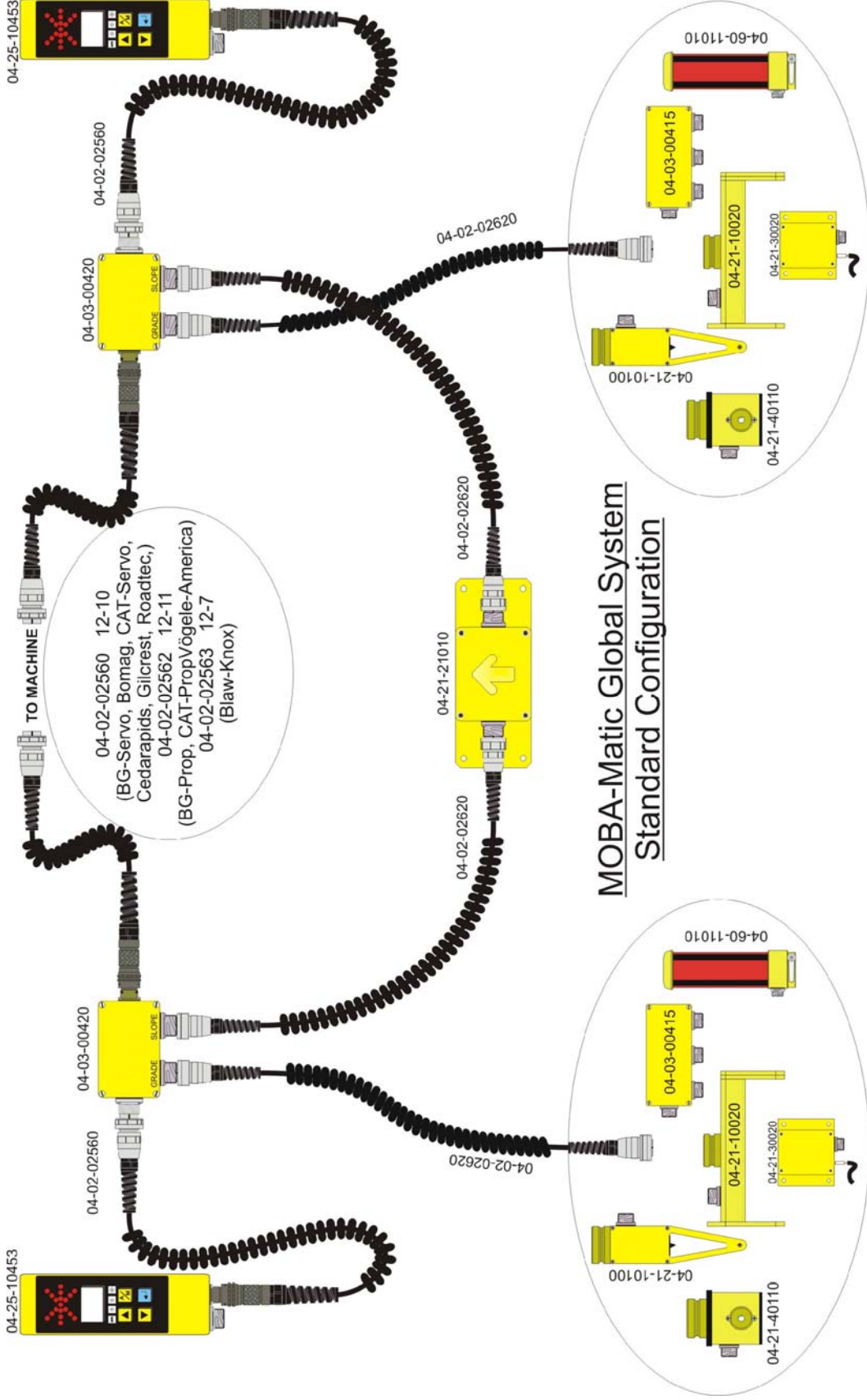

4. The digital controller

In this section the general operation of the controller is described. In the operating instructions for the individual sensors an understanding of the general operation is assumed.

4.1 Description of the digital controller

The controller can be used for most current machine types. The controller has a digital display, a LED display and four function lamps as well as push buttons to operate it.

4.1.1 LC display (liquid crystal display)

The 3½-digit liquid crystal display is easy to read because of its size and integrated nighttime illumination.

The display symbols have the following significance:

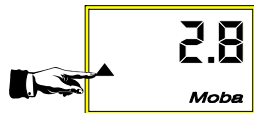

RAISE ARROW indicates the active controller output.

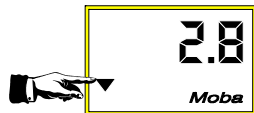

LOWER ARROW indicates the active controller output.

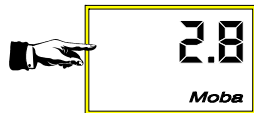

Positive indication (no sign)

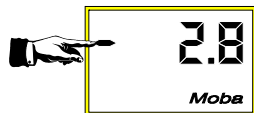

Negative indication (sign "-")



Slope to the right (bar dropping to the right).











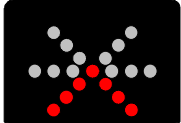



Slope to the left (bar dropping to the left).

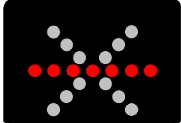

4.1.2 LED display

The LED's are only used to make the status of the valve outputs more apparent to the user. Their representation is an increased and more detailed display of the function of the arrow symbols on the LC display.

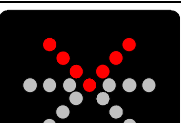
LC display	LED-display	Deviation	Outputs
 Symbol constantly on	 Arrow constantly on	Large control deviation	Output UP is constantly on
 Symbol flashes	 Arrows flashes	Medium control deviation	Output UP is pulsing with big pulse width
 Symbol flashes	 Center on/ Arrow flashes	Small control deviation	Output UP is pulsing with small pulse width
 No Symbol activated	 Center on	No control deviation	No output activated
 Symbol flashes	 Center on/ Arrow flashes	Small control deviation	Output DOWN is pulsing with small pulse width
 Symbol flashes	 Arrow flashes	Medium control deviation	Output DOWN is pulsing with big pulse width
 Symbol constantly on	 Arrow constantly on	Large control deviation	Output DOWN is constantly on





If all LED's flash at the same time there is an alarm condition.

4.1.3 Function lamps

The four function lamps have the following significance:

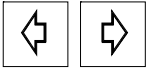

	<p>Automatic lamp</p>	
	<p>Lamp on: automatic operation</p>	
	<p>Lamp flashing: half automatic operation (only if this optional mode was preset by your MOBA-agent);</p>	
	<p>Lamp off: manual operation</p>	
	<p>Direction lamp (Special function with Sonic-Ski)</p>	
	<p>If both lamps flash at the same time there is an alarm condition.</p>	
	<p>String line lamp with Sonic-Ski</p>	<p>with Big-Ski</p>
	<p>Lamp on: String line mode active</p>	<p>Averaging of all 3 sensors</p>
	<p>Lamp off: Ground mode active (averaging)</p>	<p>Only the middle sensor is evaluated</p>

4.1.4 Push button unit

For the operation of the MOBA-matic four push buttons are available. They facilitate simple operation and only for a few settings do they have an additional function's.

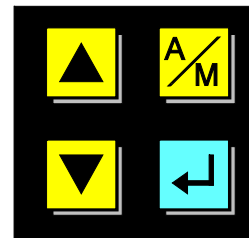

UP/DOWN push buttons

With these buttons the setpoint can be changed when in automatic mode (and in half automatic, if preset).



In manual mode the output for the respective valve is active while the button is depressed.



Automatic/Manual push button (A/M push button)

This button is used to change between manual mode, half automatic mode (if preset) and automatic mode.

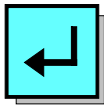

SET push button

This button is used to make the setpoint equal to the actual value and/or to zero the display.

4.1.5 Push button combinations

Automatic/Manual button + Set button

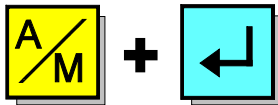

You can access the **operator menu** by pressing these two buttons simultaneously. Within the operators menu you will find important system parameters, such as "Sensor selection", "Sensitivity setting", "Control window setting", "Unit of distance setting", "Position factor" and "Hydraulic record".



or

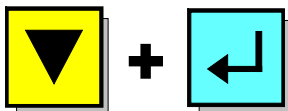

UP or DOWN button + Set button

You can **change the value indicated on the display** in both manual- or automatic mode by pressing the UP- or DOWN- button and the ENTER-key simultaneously. This process has no effect on the control function.

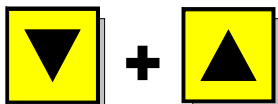

UP- + DOWN button

While working with the Sonic-Ski sensor in manual mode you can change between string line sensing and ground sensing by pushing the UP- and DOWN- buttons simultaneously.

4.2 Switch on test

After switch-on the controller performs a display test. All segments of the liquid crystal display, all light-emitting diodes of the LED display and all four function lamps are illuminated for about two seconds. If a button of the controller is pressed during the switch-on test, the display shows the software version for about 4 seconds. If any part of the display or one of the LED's does not illuminate please inform your customer service.

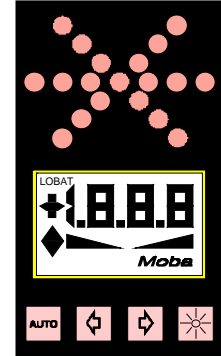

4.3 Sensor identification

After the switch-on test, the digital controller indicates the identification of the sensor that was used last in an alternating display mode. The identification of the various sensors are listed in those paragraphs dealing with their operation. In addition to this, the two direction lamps will flash. After that, the controller automatically changes over to the working mode.

Example of the sensor identification for the Sonic-Ski:

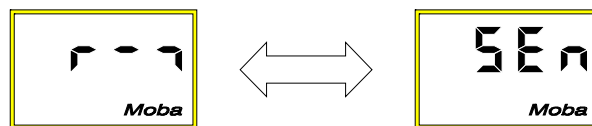

Important: If the sensor has been replaced or removed, the controller will clearly indicate this with the message shown below. The operator should be informed about this fact and about the need to check all settings for the new sensor when switching on the system. Please acknowledge this message by pressing any button.

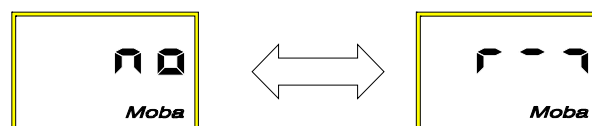

4.4 Operator menu

In the controller's operator menu, you will find all parameters and settings that are important for the control system in general and for the use of the various sensors.



Due to the fact that individual systems can have several configurations, (depending on the application and the related selection of sensors), the operator menu appears in a lot of different ways.

In order to avoid unnecessary confusion, menu points which are irrelevant for the sensor combination actually used, will not be indicated when calling the operator menu. Due to this, sometimes the operator menu has only 2 menu items; other configurations may have up to 8, depending on the application.

The result of this is that in these operating instructions we cannot make a binding statement regarding which parameter is to be found on which position. However, identifying the various menu points with individual designations makes their identification quite easy.

In the following, we will describe all menu points in their order of appearance in a fully equipped and appropriately configured system.

Listed in detail, these are:

Indication of cross slope;

Sensor selection;

3D set-point assignment;

Sensitivity setting;

Control window setting;

Unit of distance setting;

Position factor;

Hydraulic record;

The operator menu can be accessed from the working menu only.

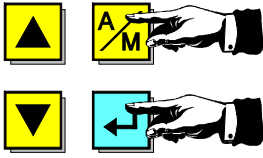

Activate the first parameter item by pressing the A/M-button and the SET-button simultaneously.

Use this button combination to switch from one parameter to the next.

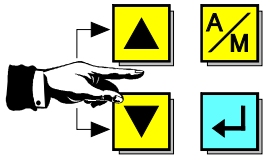

By pressing the UP-button or the DOWN-button parameter values are set or function modes are changed.



Exit the operators menu at any time by pressing the A/M-button.

4.4.1 Indication of cross slope

If a slope sensor is connected, and the grade sensor has been selected as active sensor for the controller (see also 4.4.2 "Sensor Selection"), the first thing the operator menu indicates will be the currently measured cross slope of the machine.

Procedure: Indication of cross slope. (will only be active if a slope sensor is connected to the system)

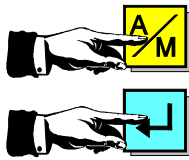

Press the A/M-button and the SET-button simultaneously.



For a short moment (approx. 1 sec.), the display shows the sign for cross-slope "SLo" and after that the measured value of the cross-slope sensor, will be indicated flashing for about 4 seconds.





Return to working mode by pressing the A/M-button. If no button is pressed for about 5 sec. the controller switches back automatically.

4.4.2 Sensor selection

If several sensors are connected, the desired sensor for the application can be selected in the operator menu under the menu point >S-S<. The controller then uses the selected sensor.

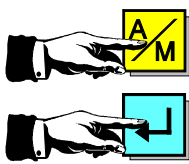
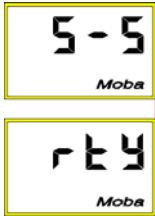
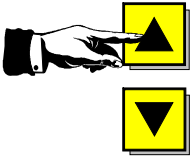
Procedure: Sensor selection (will only be active if more than one sensor is connected to the system.)

 <p>Press the A/M-button and the SET-button several times simultaneously...</p>	 <p>... until the display alternates between the sign for sensor selection "S-S" and the identification of the active sensor (here: „rtY“ for rotary sensor).</p>	 <p>Pressing the UP- or the DOWN-button to select another sensor. (here: Big Ski).</p>	 <p>Return to working mode by pressing the A/M-button. If no button is pressed for about 5 sec. the controller switches back automatically.</p>
--	--	--	--





4.4.3 3D set-point assignment

If the controller receives external 3D set-point commands (e.g. because it is integrated into a 3D-control system with GPS or a total-station), you can select here whether these shall be used for control purposes or if changes are to be done the conventional way – by manual entries from the keyboard.

A = automatic mode = 3D control;

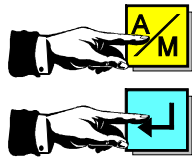
Hd = manual mode = adjustment via keyboard entries;

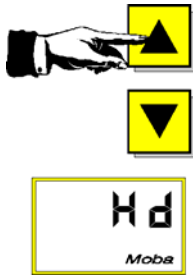
Procedure: 3D set-point assignment. (will only be active if a 3-D controller is connected to the system.)

 <p>Press the A/M-button and SET-button several times simultaneously ...</p>	 <p>... until the display alternates between the sign for 3D set point assignment "SP" and the current control mode (here: "A" for 3D control).</p>	 <p>Press the UP- or DOWN-button for a change-over to the other control variant (here: „Hd“ for manual entries).</p>	 <p>Return to working mode by pressing the A/M-button. If no button is pressed for about 5 sec. the controller switches back automatically.</p>
--	---	---	---

4.4.4 Sensitivity setting

If MOBA-matic is operated with different sensor types (grade and slope sensors) the sensitivity of the controller should be individually adjusted.



The range of adjustment of this menu point is always from 1 (low sensitivity) to 10 (high sensitivity). These figures are derived from an ingenious combination of the control parameters "Deadband" and "Propband", which was determined by an extensive test series and many years of experience.

On the next pages, you will find a comparison of the respective values as well as an explanation of what they stand for.

The sensitivity has to be adjusted separately for grade and slope sensors. If a sensor has to be replaced at a later point of time, this value will be automatically selected.

If MOBA-matic is too active in the automatic mode, the sensitivity needs to be reduced on the respective digital controller. If MOBA-matic is too sluggish in the automatic mode, the sensitivity needs to be increased.

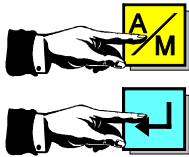
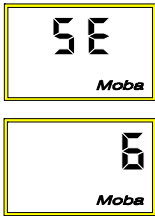
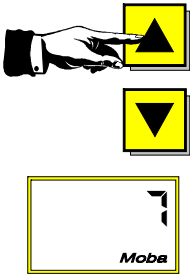
Procedure: Sensitivity setting (Always available)

 <p>Press the A/M-button and the SET-button simultaneously several times. ...</p>	 <p>... until the display alternates between the sign „SE“ for sensitivity setting and the value that was adjusted last (standard setting: „6“).</p>	 <p>The value can be increased or decreased by pressing the UP- or DOWN-button (here: setting to the value „7“).</p>	 <p>Return to working mode by pressing the A/M-button. If no button is pressed for about 5 sec. the controller switches back automatically.</p>
--	---	--	--



Your MOBA-supplier is able to change the standard setting of the controller in a way that the control parameters “Deadband” and “Proportional band” appear instead of the “Sensitivity setting” at this point of the operator menu. These can then be individually adjusted by a specialist.

Sensitivity tables for proportional and servo valves:

Sensitivity SE	Deadband db (mm)	Propband Pb (mm)
1.0	2.2	46.0
2.0	2.0	41.0
3.0	1.8	36.0
4.0	1.6	31.0
5.0	1.4	26.0
6.0	1.2	21.0
7.0	1.0	16.0
8.0	0.8	11.0
9.0	0.6	6.0
10.0	0.4	1.0

for all grade sensors

Sensitivity SE	Deadband db (%)	Propband Pb (%)
1.0	0.18	2.10
2.0	0.16	1.90
3.0	0.14	1.70
4.0	0.12	1.50
5.0	0.10	1.30
6.0	0.08	1.10
7.0	0.06	0.90
8.0	0.04	0.70
9.0	0.02	0.50
10.0	0.00	0.30

for Digi-Slope sensor

Sensitivity tables for ON/OFF valves:

Sensitivity SE	Deadband db (mm)	Propband Pb (mm)
1	5.0	18.0
2	4.0	16.0
3	3.6	14.0
4	3.4	12.0
5	3.0	10.0
6	2.4	8.0
7	2.0	6.0
8	1.6	5.0
9	1.2	4.0
10	1.0	3.0

for Sonic-Ski sensor, Big-Ski and LS 250

Sensitivity SE	Deadband db (mm)	Propband Pb (mm)
1	4.0	18.0
2	3.4	16.0
3	3.0	14.0
4	2.4	12.0
5	2.0	10.0
6	1.4	8.0
7	1.0	6.0
8	0.8	5.0
9	0.6	4.0
10	0.4	3.0

for Wire rope sensor and Rotary sensor

Sensitivity SE	Deadband db (%)	Propband Pb (%)
1	0.40	1.60
2	0.30	1.40
3	0.20	1.20
4	0.14	1.00
5	0.10	0.80
6	0.06	0.60
7	0.04	0.50
8	0.02	0.40
9	0.02	0.30
10	0.00	0.20

for Digi-Slope sensor



4.4.5 Control window setting

This menu point only appears if a grade sensor has been chosen as active sensor at the menu point "Sensor selection", because it only has effect on this type of sensor. If a control deviation appears that is bigger than the set range this control deviation will be recognised as a fault.

The display will show the symbol for the control window, both direction arrows of the LC display and the complete LED arrow flash and the drive of the hydraulic cylinders will be switched off.

The input is done in 0.1 cm, 0,1 inch or 0,01 feet steps, depending on which physical unit for the distance measurements was set (see also the next section "Unit of distance setting" of this operating instructions).

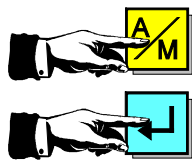
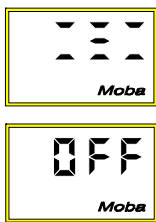
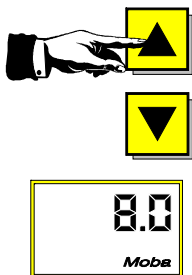

Procedure: Control window setting. (will only be active if a grade sensor is attached and is selected)

 <p>Press the A/M-button and the SET-button several times simultaneously ...</p>	 <p>... until the display alternates between the symbol for the control window "▬▬▬" and the value entered last (standard „OFF“ – which means deactivated).</p>	 <p>The size of the control window can be adjusted by pressing the UP- or DOWN-button (here: setting to the value "8.0" (3.15") [$\pm 4.0\text{cm}$ (1.575")]).</p>	 <p>Return to working mode by pressing the A/M-button. If no button is pressed for about 5 sec. the controller switches back automatically.</p>
---	--	--	--

4.4.6 Unit of distance setting

This menu point only appears if a grade sensor has been chosen as active sensor at the menu point “Sensor selection”, because it only has effect on this type of sensor. Here, the operator can preset the desired measuring unit for the displayed distance values. You can choose between the physical units “centimeter”, “inch” and “feet”.

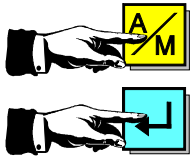
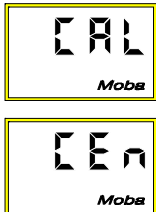
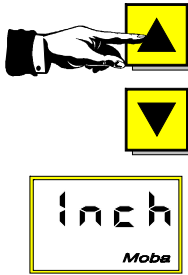
Procedure: Unit of distance setting. (will only be active if a grade sensor is attached and is selected)

 <p>Press the A/M-button and the SET-button several times simultaneously ...</p>	 <p>... until the display alternates between the sign „CAL“ for unit of distance setting and the measuring unit that was entered last (standard „CEn“ = centimeter).</p>	 <p>You can change from one physical measuring unit to another by pressing the UP- or the DOWN-button (here: setting to the unit „Inch“).</p>	 <p>Return to working mode by pressing the A/M-button. If no button is pressed for about 5 sec. the controller switches back automatically.</p>
---	---	---	--

4.4.7 Position factor

This menu point will only appear if a grade sensor has been chosen as active sensor under menu point "Sensor selection", since it only has an effect on this type of sensor, and if this selection has been activated by your MOBA-supplier during the setup of the controller. This setting is used primarily for milling machines.

Change in height of sensor x position factor = change in height of tool

How to determine the position factor:

Before we can enter a position factor, it has to be determined. In order to be able to do so an understanding of the following is required.

In most applications for which the MOBA-matic has been designed, the height adjustment of the tool to be controlled is done around a fixed pivot point.

Positions 1, 2 and 3 on the drawing are the fixed positions for the grade sensors; position 1 is also the center of the tool.

The adjustment device (in this case a hydraulic cylinder) can be positioned anywhere and has no influence on the position factor.

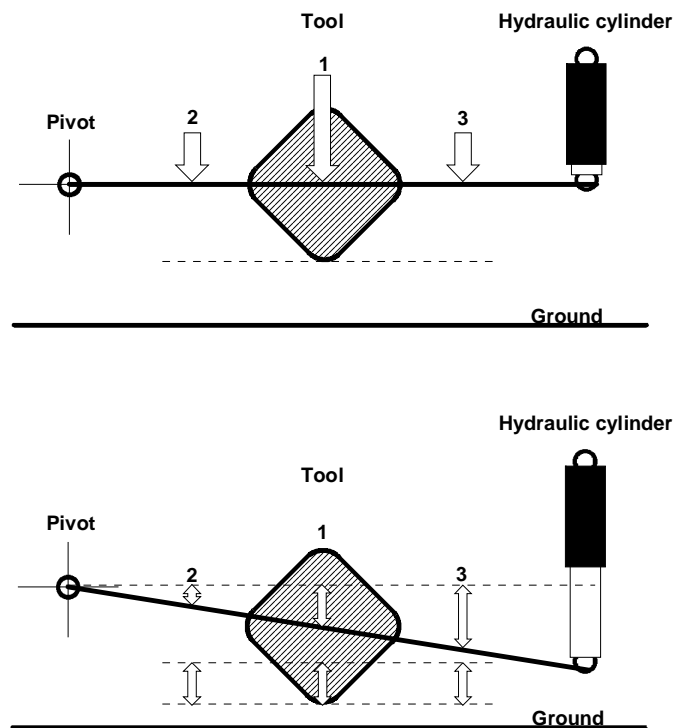

If the height sensor is fixed at position 1 - which means directly at the centre of the tool - then the change in the height of the tool will be exactly the same as the sensor's. In this special case, the position factor is exactly 1.00.

However, the situation is completely different for fixing positions 2 and 3.

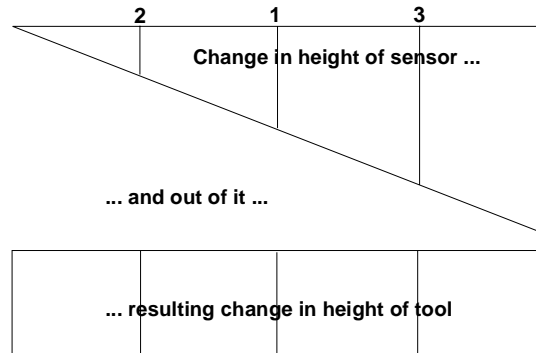

Let's have a look at position 2 first:

Here, the same change in the height of the tool as in the previous example only leads to a smaller change in the sensor's height, since the sensor is mounted closer to the pivot.

Consequently – if the sensor is fixed between the pivot and the center of the tool – the position factor always has to be bigger than 1.00 in order to equal out this situation.



However, in position 3, the change in the height of the sensor is considerably larger than the tool's. Consequently, the position factor has to be smaller than 1.00, since the sensor is located farther away from the pivot than the tool.

Determine the position factor using the following formula:

$$\frac{\text{Distance of fixed pivot to the tool}}{\text{Distance of fixed pivot to the sensor}} = \text{Position factor}$$

For example: If the distance from the pivot point to the tool is 8 feet and the distance to the sensor is 6 feet then the position factor is $8/6 = 1.33$. If the distance from the pivot point to the sensor is 10 feet then the position factor is $8/10 = 0.80$.

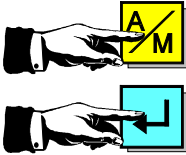
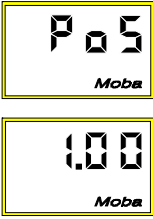
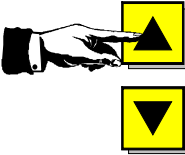
Procedure: Position factor setting (Only available if the controller is set up to allow the position factor to be changed by your MOBA dealer.)



 <p>Press the A/M-button and the SET-button several times simultaneously ...</p>	 <p>... until the display alternates between the sign for the position factor „PoS“ and the preset value „1.00“.</p>	 <p>You can change the position factor by pressing the UP- or DOWN-button.</p> 	 <p>Return to working mode by pressing the A/M-button. If no button is pressed for about 5 sec. the controller switches back automatically.</p>
---	---	---	--

4.4.8 Hydraulic record

If the MOBA-matic system is to be used on several machines, it is possible for the MOBA-agent to store different hydraulic parameter settings for up to 40 different machine types (the maximum number of hydraulic types can be limited by your MOBA-supplier during the initial setup of the controller).

Use menu point „Hydraulic record“ to load the stored settings for the corresponding machine.

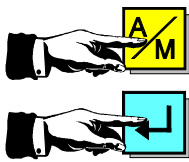
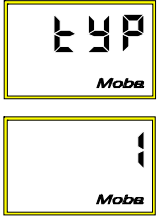
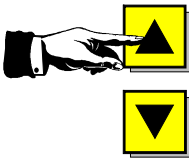
Procedure: Hydraulic record setting (Always available)

 <p>Press the A/M-button and the SET-button several times simultaneously ...</p>	 <p>... until the display alternates between the sign for the hydraulic record setting "tYP" and the hydraulic record selected last (default "1").</p>	 <p>Switch-over between the stored hydraulic record is done by pressing the UP- or the DOWN-button (here: setting hydraulic type "2").</p>	 <p>Return to working mode by pressing the A/M-button. If no button is pressed for about 5 sec. the controller switches back automatically.</p>
---	---	--	--

4.4.9 Graphic representation of the operator menu

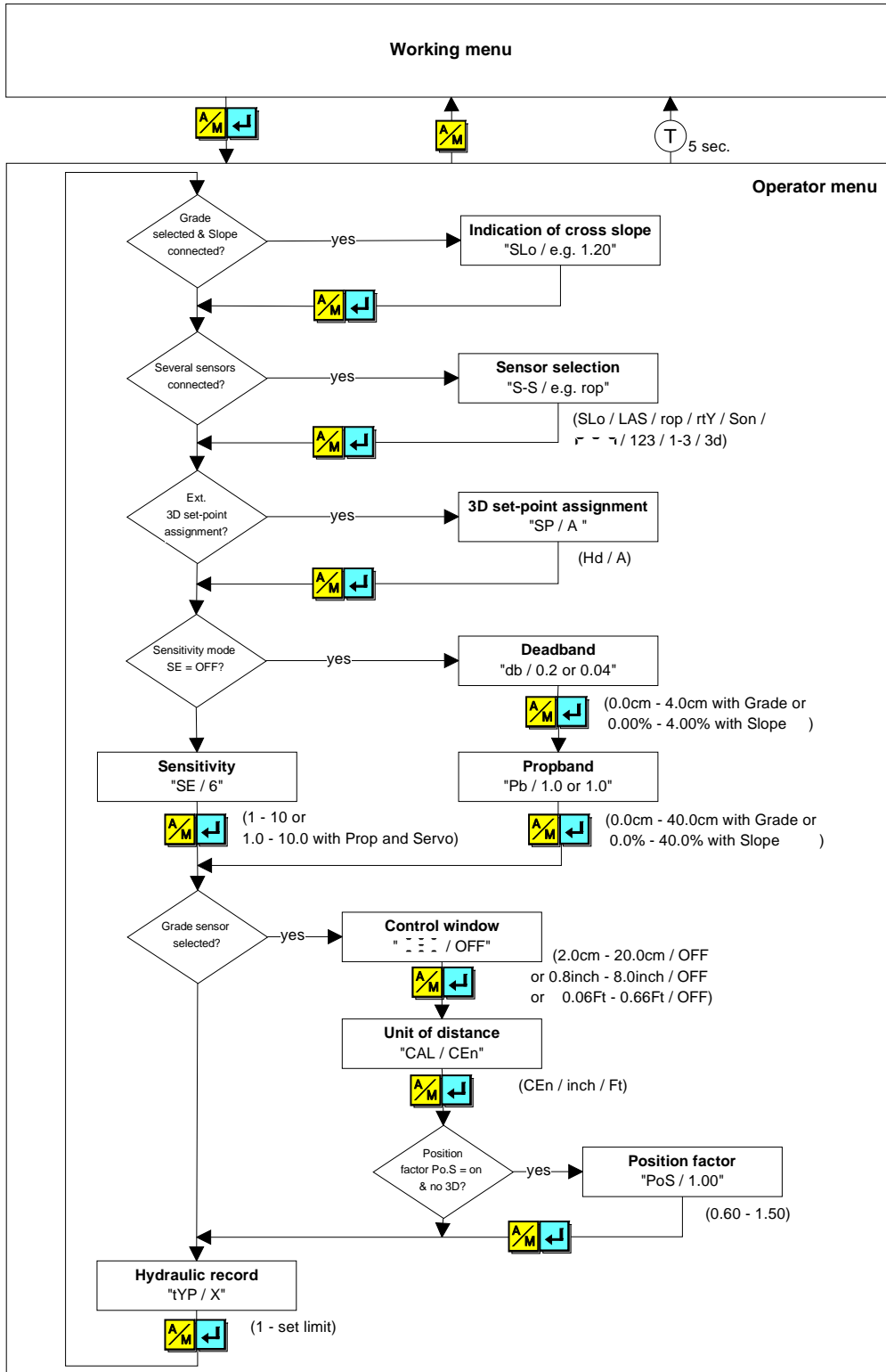

4.5 Different user settings

Your MOBA-agent can set the operation of the controller, selecting from three possibilities. The differences are the follows:

STANDARD

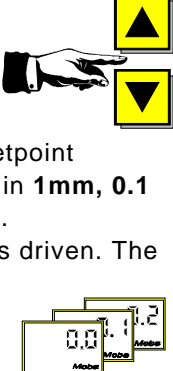
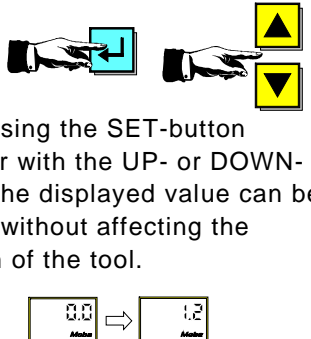
<p>Set point setting</p> <p>The setpoint can be changed with the UP/DOWN-buttons. In automatic mode the setpoint changes continuously in 1mm, 0.1 inch or 0.01 foot steps. ATTENTION! The tool is driven. The changed setpoint is indicated at the display.</p> 	<p>Indicated value</p> <p>By pressing the SET-button together with the UP- or DOWN-button the displayed value can be altered without affecting the position of the tool.</p> 
--	--

HALF AUTOMATIC (Changing the setpoint without active control outputs)

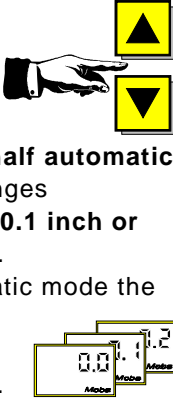
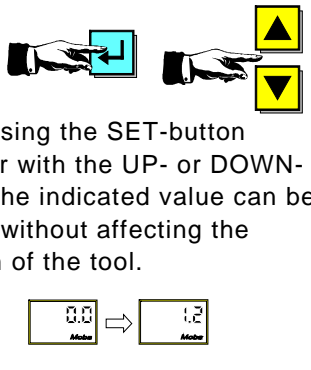
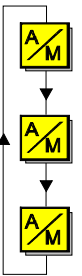
<p>Set point setting</p> <p>The setpoint can be changed with the UP/DOWN-buttons. In automatic mode and half automatic mode the setpoint changes continuously in 1mm, 0.1 inch or 0.01 foot steps. ATTENTION! In automatic mode the tool is driven. The changed setpoint is indicated at the display.</p> 	<p>Indicated value</p> <p>By pressing the SET-button together with the UP- or DOWN-button the indicated value can be altered without affecting the position of the tool.</p> 	<p>The switch over between manual, half automatic and automatic mode is done continuously by pressing the A/M-button.</p>  <ul style="list-style-type: none"> manual LED off Control outputs inactive No setpoint changing half automatic LED flashing Control outputs inactive Setpoint changing possible automatic LED on Control outputs active Setpoint changing possible
---	--	--

AUTO ZERO

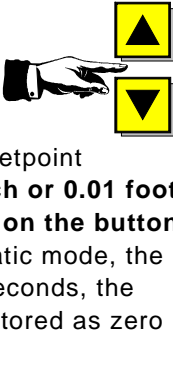
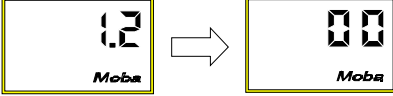
<p>Set point setting</p> <p>The setpoint can be changed with the UP/DOWN-buttons. In automatic mode the setpoint changes in 2mm0.1 inch or 0.01 foot steps with every push on the button. ATTENTION! In automatic mode, the tool is driven. After 5 seconds, the value in the display is stored as zero point.</p> 	<p>Indicated value</p> 
---	--

The following operating instructions for the various sensors is based on the controller's standard presetting (see previous page).

Specific differences in the user settings (such as the half automatic mode or different step sizes for the set point adjustment) have no influence on the general operating procedures.

5. The Digi-Slope sensor

5.1 Description

The Digi-Slope sensor works with a very precise, electro-mechanical measuring instrument and is used to detect the tool's slope.

Sensor identification:

After switch-on or if a sensor has been changed, the display alternates between the sign for the Digi-**S**lope sensor and the side identification (right = right or left = **left**).

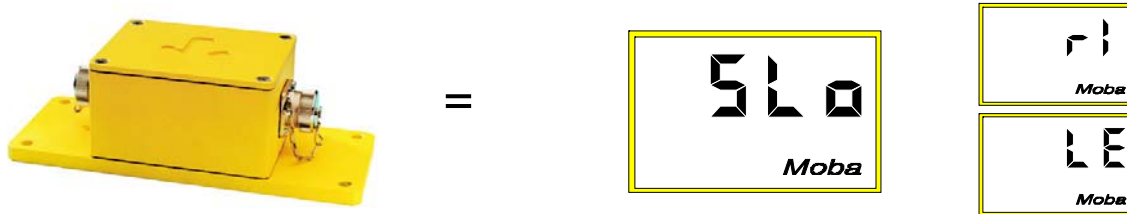

5.2 Mounting

The Digi-Slope sensor needs to be mounted on a part of the machine that moves with all slope changes in the same way as the tool does.

With milling machines, the lower the sensor is the better. (e.g. on the milling drum housing); in case of a paver, we recommend the cross linkage (transverse beam) between the tow arms.

For mounting purposes, four fixing holes are provided in the fixing plate of the sensor (for drawing, see paragraph 13 "Technical data"). Shock absorbers should be installed between the mounting plate and the chassis.

The connectors must be accessible, so that the interconnecting cable can be easily plugged in. Please observe the direction of mounting (FWD/arrow in direction of travel).

5.3 Operation of the Digi-Slope sensor

It is assumed that the Digi-Slope sensor and the digital controller are mounted, the cables are connected and the digital controller has its voltage supply. After the switch-on message, the digital controller indicates the sensor identification. As soon as the message of the connected sensor disappears, the system will be operable. If the sensor is being used for the first time or has been changed, the sensor identification must be acknowledged by pressing any one of the push buttons. Select a sensor as described in the previous chapter, if necessary.

Procedure: Acknowledgement of the sensor identification

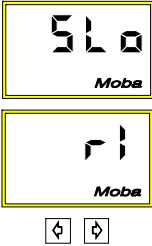
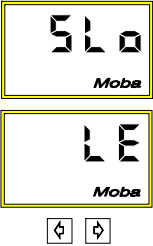
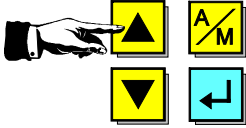
 <p>The digital controller indicates the sensor identification (here: right).</p>	<p>1b</p>  <p>The digital controller indicates the sensor identification (here: left).</p>	<p>2</p>  <p>If the sensor is connected for the first time or has been replaced, the sensor identification has to be acknowledged by pressing any button.</p>
---	--	--









5.3.1 Setting up the measured value



The setting of the measured value needs to be done only once – during the initiation of the slope sensor. With this procedure, the indicated measured value of both digital controllers is adjusted to the actual cross-slope of the tool to be controlled. For this purpose, the angle of slope is determined with a spirit level or by placing the tool on a predetermined slope.

In the following example, we will describe how to set the indicated measured value from 2,45% to the actual value of 2,30%.

Procedure: Setting up the measured value

<p>1  → </p>  <p>Switch to the manual mode with the A/M-button. The function lamp "AUTO" is off. The display shows the measured value of the tool.</p>	<p>2 </p>  <p>Press the the SET-button and keep it pressed. The display indicates "SEt" and then changes back to the measured value.</p>	<p>3 </p>  <p>Keep the SET-button pressed and adjust the measured value to 2.30% with the UP/DOWN-buttons.</p>
---	--	---

A correction of the indicated measured value is possible anytime – also in the automatic mode during work.









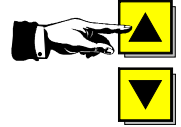

Every time one of the controllers or the Digi-Slope sensor is exchanged, or if the mounting position of the sensor is changed, the procedure for setting up the measured value needs to be repeated.

5.3.2 Controlling with the Digi-Slope sensor

It is assumed that the Digi-Slope sensor is mounted, the cables are connected and the setting of the measured value is done.

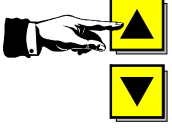
Procedure: Controlling with the Digi-Slope sensor

<p>1</p>  <p>Switch over to the manual mode with the A/M-button. The function lamp "AUTO" is off.</p>	<p>2</p>  <p>Bring the tool into working position with the UP/DOWN-buttons at the controller or with the operating unit at the machine.</p>  <p>(here: 5,35%, slope to the right)</p>	<p>3</p>   <p>Now the SET-button must be pressed to set the angle of slope of the tool as set point. The display indicates "SET".</p>	<p>Attention: It is absolutely essential to carry out step no. 3. If disregarded, this will move the tool into an undefined position when switching over to automatic mode.</p>
<p>4</p>  <p>The display indicates the measured value again.</p>	<p>5</p>  <p>Switch to the automatic mode by pressing the A/M-button. The function lamp "AUTO" is on.</p>	<p>6</p>  <p>The controller now indicates 5.35% as set point. The controller now controls to this value. A control deviation will be indicated with the RAISE/LOWER-arrows.</p>	<p>7</p>  <p>The set point can be changed step by step using the UP/DOWN-buttons. The controller will then control to this new value.</p>  <p>(here: 6.00%, right slope)</p>



At any time you can switch back to the measured value in order to check the tool's slope by pressing the A/M-button. However, the automatic drive of the valves will then be switched off.

Sensitivity setting

If the control in automatic mode is too sluggish or too active the sensitivity setting should be changed accordingly. The procedure is described in section 4.4.4 of these operating instructions.

6.The Sonic-Ski sensor

6.1 Description

The Sonic-Ski sensor is used for non-contacting elevation control. It uses 6 ultrasonic elements, 5 for elevation measurements and 1 for temperature compensation.

Sensor identification:

After switch-on or if a sensor has been changed, the display alternates between the symbol for the Sonic-Ski and the sign for **sensor**.

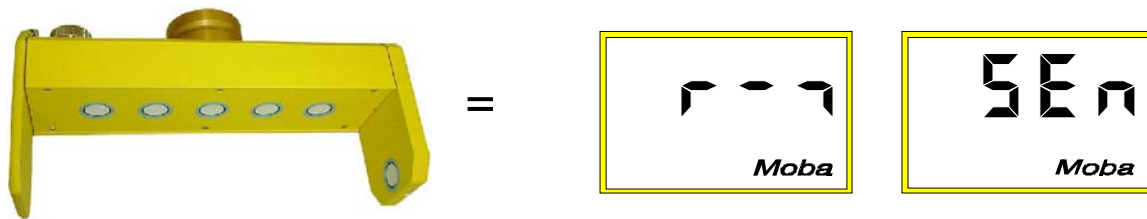

6.2 Mounting instructions and working range

The Sonic-Ski can be mounted easily and quickly using simple tools. For this purpose, a fastening tube should be fitted at a suitable position (paver: on the tow arm; milling machine: on the frame).

Procedure:

1. Loosen the locking handles on the mounting tube.
2. Insert the center pivot of the sensor into the mounting tube.
3. Turn the sensor housing according to the required direction of travel.
4. Fix the center pivot with the locking handle.

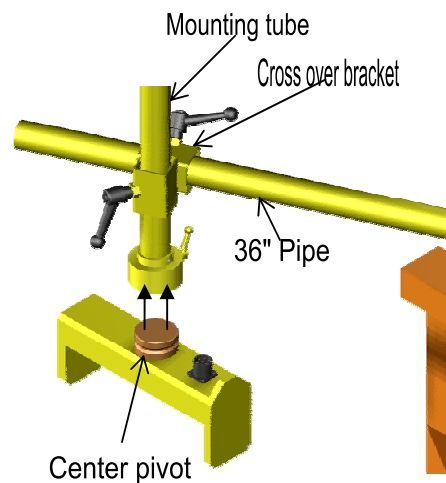

Direction of travel:

The direction of travel of the Sonic-Ski is determined as follows:

When **ground sensing**, the Sonic-Ski should work in parallel to the direction of travel. (averaging is done by the Sonic-Ski).

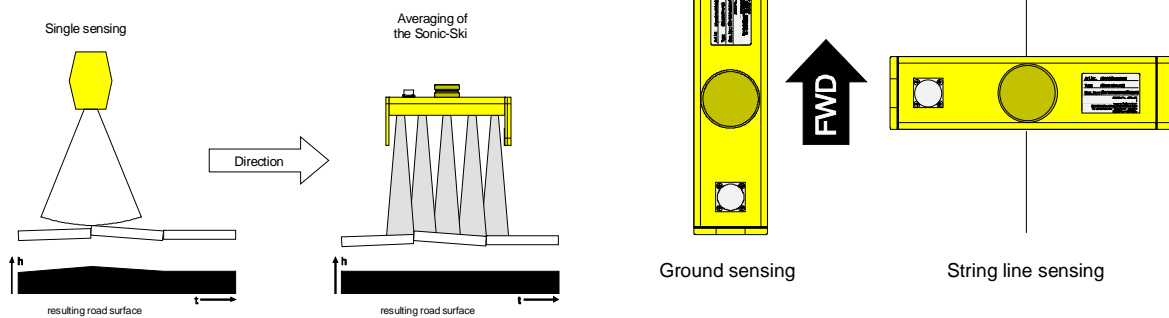

When **string line sensing**, the Sonic-Ski should operate perpendicular to the direction of travel, so that the full working width of 25 cm is available.

The working range:

The working range for ground- and string line sensing is between 30cm and 40cm (11.75 in and 15.75in).

In this range, the measured value is indicated with a constant display, otherwise the display flashes (positioning aid).

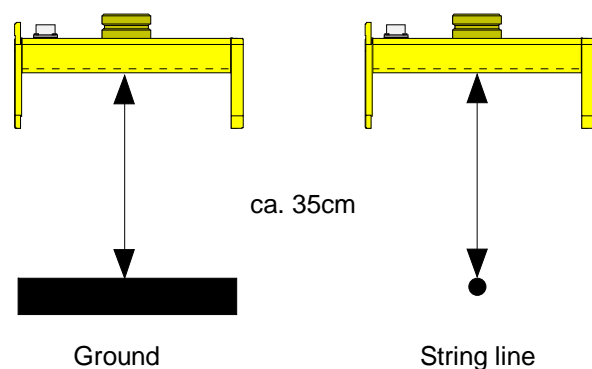

The Sonic-Ski should be adjusted at a distance of approx.. 35 cm (13.75in) from the reference.



6.3 Working with the Sonic-Ski sensor

It is assumed that the Sonic-Ski and the digital controller are mounted, the cables are connected and the digital controller has its voltage supply. After the switch-on message, the digital controller indicates the type of sensor. As soon as this message disappears automatically, the system is ready for work. If the sensor is used for the first time or has been changed, the sensor identification must be acknowledged by pressing any one of the push buttons. If necessary, select this sensor as described in section 4.

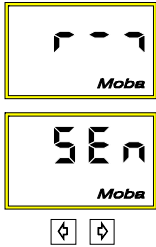
Procedure: Acknowledgement of the sensor identification

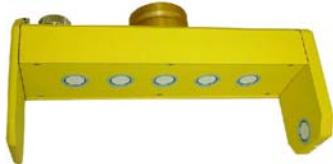
 <p>The digital controller indicates the sensor identification of the Sonic-Ski.</p>	 <p>If the sensor is connected for the first time or has been changed, the sensor identification must be acknowledged by pressing any button.</p>	
--	--	---





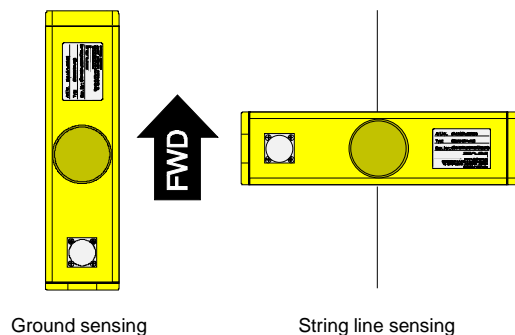



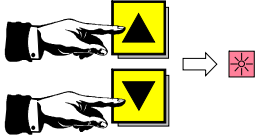
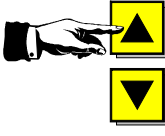
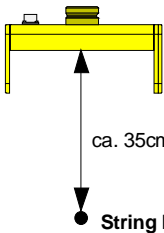

At this point we want to remind you once again of the working directions for ground- and string line sensing and the optimal work range of the Sonic-Ski. Both specifications have to be strictly observed in order to obtain optimal results.

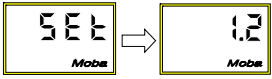

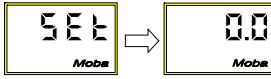
6.3.1 String line sensing

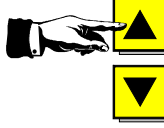





Procedure: String line sensing

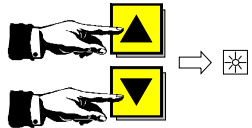
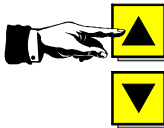
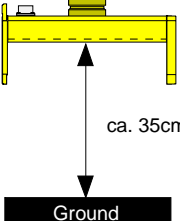

<p>1</p>  <p>Switch to the manual mode with the A/M-button. The function lamp "AUTO" is off.</p>	<p>2</p>  <p>The string line mode is activated by pressing the UP/DOWN-buttons simultaneously. The string line lamp is on.</p>	<p>3</p>  <p>For zero setting, bring the tool into working position using the UP/DOWN-buttons at the controller or the operating unit at the machine.</p>	<p>4</p>  <p>Position the Sonic-Ski 35 cm above the string line (measured value indication is constantly on).</p>
<p>5</p>  <p>The Sonic-Ski has to be positioned in the middle above the string line (both direction arrows off). Lamps off = string line in the middle / lamp on = string line in half middle / lamp flashes = string line outside. Readjust the Sonic-Ski, if the string line is out of range.</p>	<p>6a</p>   <p>Now, the SET-button is pressed. If pressed for a short time, the display indicates "SEt" and the actually measured value is stored as set point.</p>	<p>6b</p>   <p>If the SET-button is pressed for more than 1,5 seconds, the display changes from "SEt" to "0.0" and the measured value and the set point are both set to zero.</p>	<p>7</p>  <p>Switch to the automatic mode with the A/M-button. The function lamp "AUTO" is on.</p>  <p>The controller keeps the tool at the adjusted value.</p>
<p>8</p>  <p>In order to be able to make corrections, the set point can be changed in the automatic mode using the UP/DOWN-buttons.</p>	<p>9</p>  <p>You can switch back to manual mode anytime with the A/M-button. The automatic control of the valves will then be switched off.</p>	 <p>Adjustment and indication of the set point differ according to the selected operation mode (see also section 4.5 „Different user settings“).</p>	

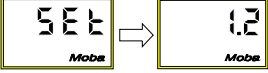
6.3.2 Ground sensing

Procedure: Ground sensing

<p>1</p>  <p>Switch to the manual mode using the A/M-button. The function lamp "AUTO" is off.</p>	<p>2</p>  <p>The ground mode is activated by pressing the UP/DOWN-buttons simultaneously. The string line lamp is off.</p>	<p>3</p>  <p>For zero setting, bring the tool into working position using the UP/DOWN-buttons at the controller or the operating unit at the machine.</p>	<p>4</p>  <p>Position the Sonic-Ski 35 cm above the ground (measured value indication has to be constantly on).</p>
--	---	---	--

<p>5</p>  <p>The two direction arrows are without any meaning when in the ground sense mode.</p>	<p>6a</p>   <p>Now, the SET-button is pressed. If pressed for a short time, the display indicates "SEt" and the actually measured value is stored as set point.</p>	<p>6b</p>  <p>> 1,5 Sek.</p>  <p>If the SET-button is pressed for more than 1,5 seconds, the display changes from "SEt" to "0.0" and the measured value and the set point are both set to zero.</p>	<p>7</p>  <p>Switch to the automatic mode with the A/M-button. The function lamp "AUTO" is on.</p>  <p>The controller keeps the tool at the adjusted value.</p>
---	---	--	--

<p>8</p>  <p>In order to make corrections, the set point can be changed in the automatic mode using the UP/DOWN-buttons.</p>	<p>9</p>  <p>You can switch back to manual mode anytime with the A/M-button. The automatic control of the valves will then be switched off.</p>
---	--



Adjustment and indication of the set point differ according to the selected operation mode (see also section 4.5 „Different user settings“).

Sensitivity

If the control is too sluggish or too active in the automatic mode, the sensitivity setting should be changed accordingly (see section 4.4.4 of these operating instructions).

Control window

The control window is active in both operating modes (string line- and ground sensing). The setting of the control window is described in section 4.4.5 of these operating instructions.

7. The Rotary sensor

7.1 Description

The rotary sensor is used for elevation control and senses its measured values from an existing reference by use of mechanical means. This may be a string line or the surface (e.g. road surface).

Sensor identification:

After switch-on or if a sensor has been changed, the display alternates between the sign for **Rotary** and the sign for **sensor**.

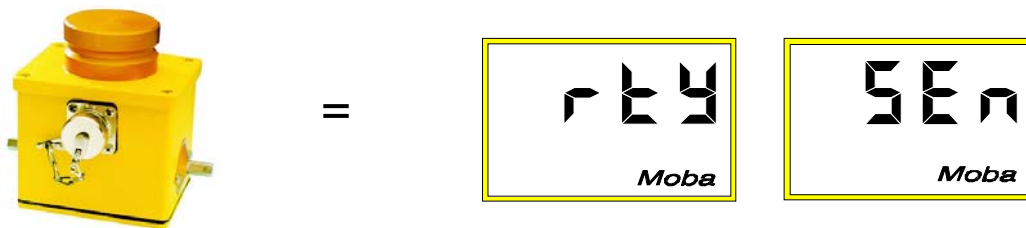

7.2 Mounting instructions and possible applications

Two aids are available for sensing the different references. The sensing tube is used when sensing a string line; the sensing ski when sensing a surface.

Mounting the sensing tube to the sensing arm

Loosen the nut at the end of the sensing tube.

Slide the sensing tube into the fastening ring of the sensing arm.

Secure the sensing tube with the nut.

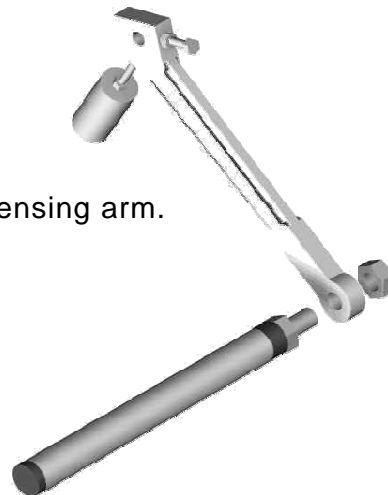

Mounting the sensing ski to the sensing arm

1. Loosen the security pin from the sensing ski bolt; remove bolt.
2. Insert the sensing arm with the fastening ring into the ski fastening.
3. Insert the bolt through the ski fastening and the fastening ring.
4. Secure the bolt with the security pin.



Mounting the sensing arm to the Rotary Sensor

1. Turn the flat side of the axle towards the side opposite of the plug.
2. Loosen the sensing arm locking screw.
3. Fit the sensing arm onto the axle.
4. Tighten the locking screw to the flat part of the axle.



The Rotary Sensor can be mounted quickly and easily with simple tools. For this purpose, a fastening tube should be fitted at a suitable position (paver: tow arm at the height of the material auger; milling machine: at the chassis above the milling drum).

Procedure:

1. Loosen the adjustable clamping handle on the mounting tube.
2. Insert the center pivot of the sensor into the mounting tube.
3. Turn the sensor housing according to the direction of travel (connector plug in direction of travel).
4. Fix the center pivot with the locking screw or screws.

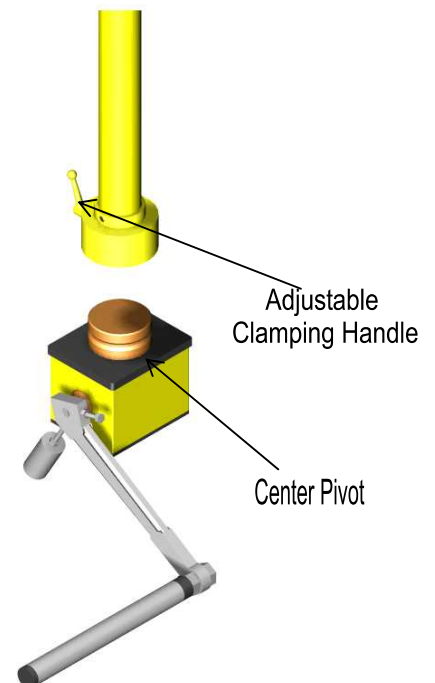

String line sensing (with sensing tube):

Set the counterweight in a way that the sensing tube exerts a slight pressure on the string line in downward direction. If the string line used as a reference does not have enough tension, the sensing tube can be set up below the string line. For this purpose, the counterweight has to be adjusted in a way that the sensing tube exerts a slight pressure onto the string line in upward direction.

Ground sensing (with sensing ski):

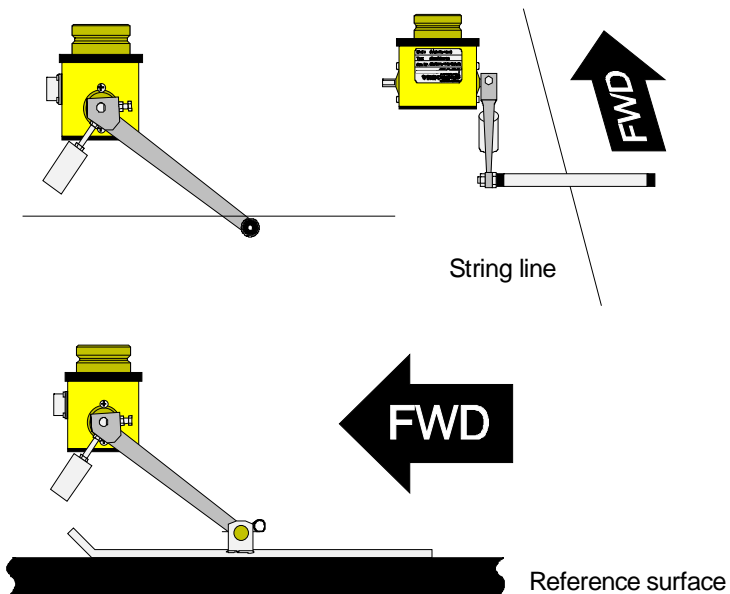

Set the counterweight so that the the sensing ski exerts a slight pressure onto the reference.



7.3 Working with the Rotary sensor

It is assumed that the Rotary Sensor and the digital controller are mounted, all cables are connected and that the digital controller has its voltage supply. After the switch-on message, the digital controller indicates the type of sensor. As soon as the identification disappears, the system is operable. If the sensor is being used for the first time or has been changed, the sensor identification has to be acknowledged by pressing any one of the push buttons. If necessary, select a sensor as described in section 4.

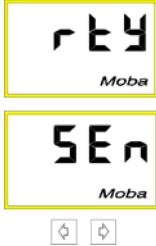
Procedure: Acknowledgement of the sensor identification

 <p>The digital controller indicates the sensor identification.</p>	 <p>If the sensor is connected for the first time or has been changed, the sensor identification has to be acknowledged by pressing any button.</p>
---	--







ATTENTION!

Please pay attention to the pressure the sensing tubes exerts onto the string line or the sensing ski exerts onto the ground.

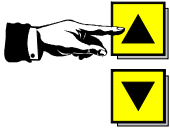
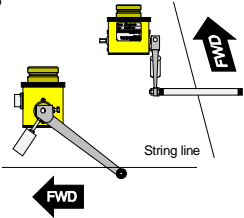
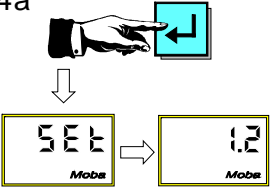
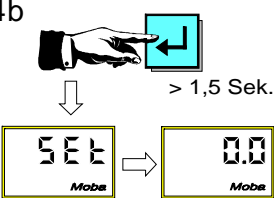
7.3.1 String line sensing

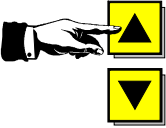
Procedure: String line sensing





<p>1</p>  <p>Press the A/M-button to switch to the manual mode. The function lamp "AUTO" is off.</p>	<p>2</p>  <p>For zero setting, bring the tool into working position using the UP/DOWN-buttons at the controller or the operating unit at the machine.</p>	<p>3</p>  <p>The sensing tube must exert a slight pressure onto the string line. The pressure can be adjusted with the counterweight.</p>	<p>4a</p>  <p>Now, the SET-button is pressed. If pressed for a short time, the display indicates "SET" and the actually measured value is stored as set point.</p>
<p>4b</p>  <p>If the SET-button is pressed for more than 1,5 seconds, the display changes from "SET" to "0.0" and the measured value and the set point are both set to zero.</p>	<p>5</p>  <p>Switch to the automatic mode with the A/M-button. The function lamp "AUTO" is on.</p>  <p>The controller keeps the tool at the adjusted value.</p>	<p>6</p>  <p>In order to make corrections, the set point can be changed in the automatic mode using the UP/DOWN-buttons.</p> <p>ATTENTION! Each adjustment changes the weight force of the sensing tube!</p>	<p>7</p>  <p>You can switch back to manual mode anytime with the A/M-button. The automatic control of the valves will then be switched off.</p>

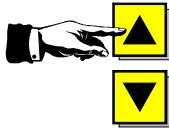
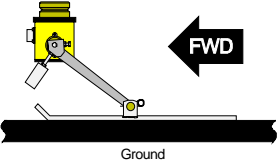
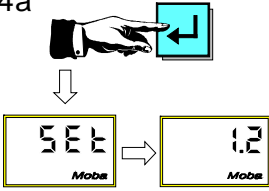
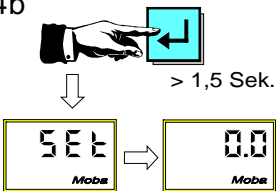

Adjustment and indication of the set point differ according to the selected operation mode (see also section 4.5 „Different user settings“).

7.3.2 Ground sensing

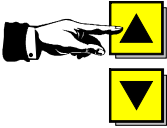
Procedure: Ground sensing

<p>1</p>  <p>Press the A/M-button to switch to manual mode. The function lamp "AUTO" is off.</p>	<p>2</p>  <p>For zero setting, bring the tool into working position using the UP/DOWN-buttons at the controller or the operating unit at the machine.</p>	<p>3</p>  <p>The sensing ski has to exert a slight pressure onto the ground. The pressure can be adjusted with the counterweight.</p>	<p>4a</p>  <p>Now, the SET-button is pressed. If pressed for a short time, the display indicates "SEt" and the actually measured value is stored as set point.</p>
<p>4b</p>  <p>If the SET-button is pressed for more than 1,5 seconds, the display changes from "SEt" to "0.0" and the measured value and the set point are both set to zero.</p>	<p>5</p>  <p>Switch to automatic mode with the A/M-button. The function lamp "AUTO" is on.</p>  <p>The controller keeps the tool at the adjusted value.</p>	<p>6</p>  <p>In order to make corrections, the set point can be changed in the automatic mode using the UP/DOWN-buttons.</p> <p>ATTENTION! Each adjustment changes the weight force of the sensing ski!</p>	<p>7</p>  <p>You can switch back to manual mode anytime with the A/M-button. The automatic control of the valves will then be switched off.</p>



Adjustment and indication of the set point differ according to the selected operation mode (see also section 4.5 „Different user settings“).

Sensitivity

If the control system is too sluggish or too active in the automatic mode, the sensitivity should be changed accordingly. (see section 4.4.4 of these operating instructions).

Control window

When operating the digital controller with the Rotary Sensor, the control window is active. The setting of the control window is described in section 4.4.5 of these operating instructions.

8. The Wire Rope sensor (YOYO)

8.1 Description

The wire rope sensor is mainly used in connection with the milling machine. It is used for elevation control and has a measuring range of 50 cm (19.68 inches).

Sensor identification:

After switch-on or if a sensor has been changed, the display alternates between the sign for wire **rope** and the sign for **sensor**.

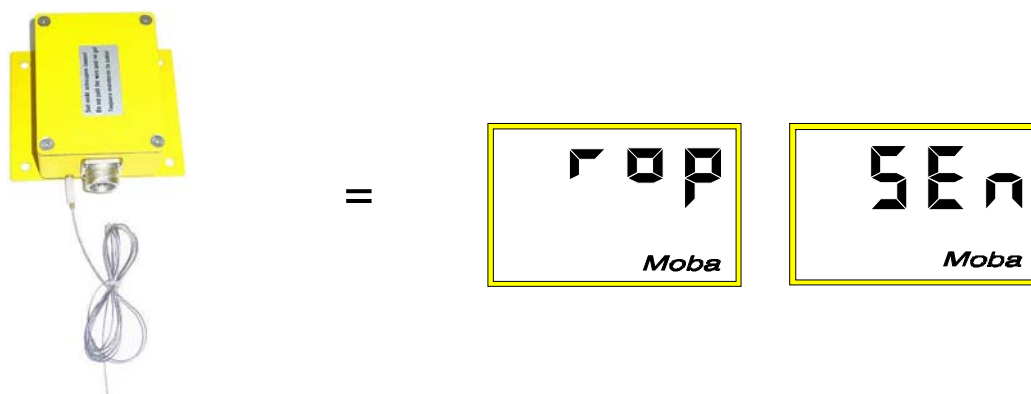

8.2 Mounting

There are mounting holes on the side of the machine, above the milling drum (for a drawing of the sensor housing, see section 13 "Technical data"). There, the sensor is installed with the rope outlet downwards (so that no moisture can seep in). The rope can be pulled out approximately 50 cm (19.5") and is hung or fixed at the designated place at the side shield of the milling machine.



When working with the milling machine with completely lowered side shield, the rope of the wire rope sensor should always be pulled out up to approx. 3 cm (1.18"), in order to make use of the maximum measuring range of the sensor.

For other applications, the rope should be fixed in a way that a maximum working range is available for the intended application.

The rope inlet in relation to the outlet must always be done vertically to the sensor.

Right:

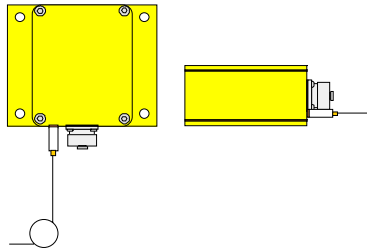

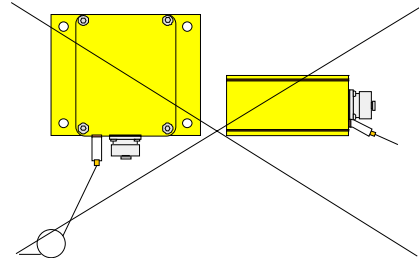

Wrong:



8.3 Working with the Wire Rope sensor

It is assumed that the wire rope sensor and the digital controller are mounted, the cables are connected and the digital controller has its voltage supply. After the switch-on message, the digital controller indicates the sensor identification. As soon as the message disappears, the system will be operable. If the sensor is being used for the first time or has been changed, the sensor identification has to be acknowledged by pressing any one of the push buttons. If necessary, select this sensor as described in section 4.

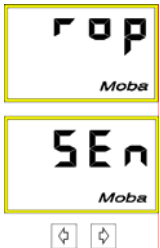



Procedure: Acknowledgement of the sensor identification

 <p>The digital controller indicates the sensor identification.</p>	 <p>If the sensor is connected for the first time or has been changed, the sensor identification has to be acknowledged by pressing any button.</p>
---	--

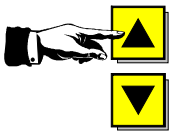
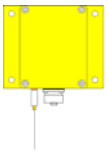
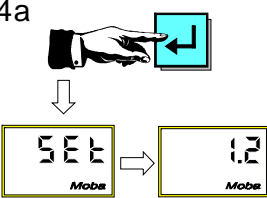
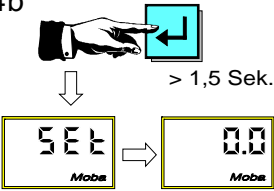

8.3.1 Controlling with the Wire Rope sensor

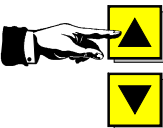
Procedure: Controlling with the Wire Rope sensor

<p>1</p>  <p>Press the A/M-button to switch to the manual mode. The function lamp "AUTO" is off.</p>	<p>2</p>  <p>For zero setting, bring the tool into working position using the UP/DOWN-buttons at the controller or the operating unit at the machine.</p>	<p>3</p>  <p>Check the fixing of the rope: Is the working range big enough for the intended application?</p>	<p>4a</p>  <p>Now, the SET-button is pressed. If pressed for a short time, the display indicates "SET" and the actually measured value is stored as set point.</p>
<p>4b</p>  <p>If the SET-button is pressed for more than 1,5 seconds, the display changes from "SET" to "0.0" and the measured value and the set point are both set to zero.</p>	<p>5</p>  <p>Switch to the automatic mode with the A/M-button. The function lamp "AUTO" is on.</p>  <p>The controller keeps the tool at the adjusted value.</p>	<p>6</p>  <p>In order to be able to make corrections, the set point can be changed in the automatic mode using the UP/DOWN-buttons.</p>	<p>7</p>  <p>You can switch back to manual mode anytime with the A/M-button. The automatic control of the valves will then be switched off.</p>



Adjustment and indication of the set point differ according to the selected operation mode (see also section 4.5 „Different user settings“).

Sensitivity

If the control is too sluggish or too active in the automatic mode, the sensitivity should be changed accordingly (see section 4.4.4 of these operating instructions).

Control window

When operating the digital controller with a wire rope sensor, the control window is active. The control window setting is described in section 4.4.5 of these operating instructions.

9. The laser receiver LS 250

9.1 Description

The laser receiver is a sensor used for elevation control, which is suitable for all standard rotation lasers such as red light transmitters (helium, neon) and infra red transmitters. Among other applications, it is used for the construction of sports fields and has a range of reception of approx. 25 cm.

Sensor identification:

After switch-on or if a sensor has been changed, the controller display alternates between the sign for the **L**aser receiver LS 250 and the sign for **s**ensor.

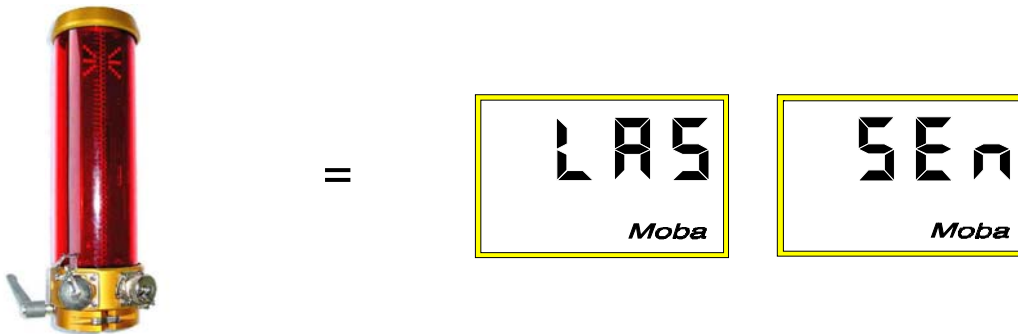

9.2 Mounting instructions

In order to mount the laser receiver, a mast should be available on the machine.

The best place of installation at the milling machine is the outside of the machine, above the milling drum axle. For a paver, it would be the outer edge of the screed, slightly ahead of the auger.

The mast for the laser receiver should have a diameter of 45mm.

Make sure that the Laser Receiver is mounted high enough so that no obstacles can come between the laser transmitter and the Laser Receiver. Also reflections of the transmitter due to smooth surfaces near the receiver should be avoided.

The LS 250 is a linear Laser Receiver. The working point can be set and changed easily with a simple push button action. Nevertheless the LS 250 should be mounted so that the laser transmitter strikes it in the center. So that there is the possibility to change the working point over the hole range.

It is really easy to mount the LS 250:

1. Open the clamp.
2. Slide the LS 250 over the mast tube.
3. Tighten the clamp.

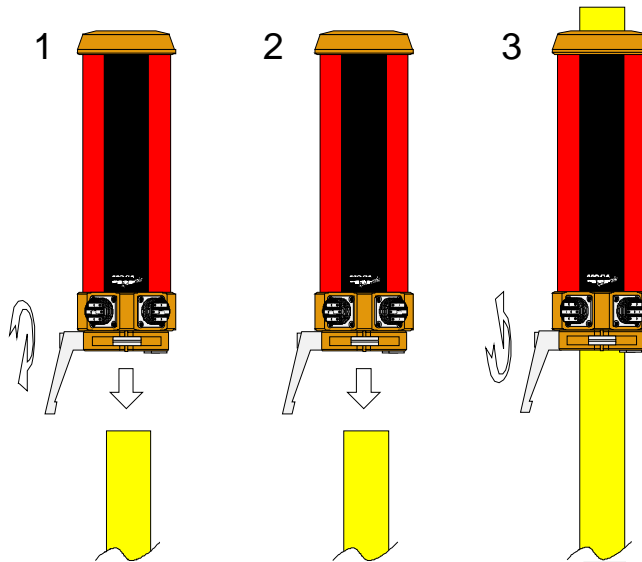

9.3 Working with the laser receiver LS 250

It is assumed that the laser receiver and the digital controller are mounted, that all cables are connected, that the controller has its voltage supply and that a laser transmitter has been put into operation. After the switch-on message, the digital controller indicates the sensor identification. As soon as the message disappears, the system will be operable. If the sensor is being used for the first time or has been changed, the sensor identification has to be acknowledged by pressing any one of the push buttons. If necessary, select this sensor as described in section 4 of these instructions.

Procedure: Acknowledgement of the sensor identification

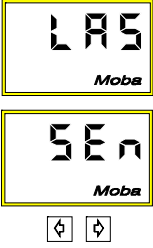
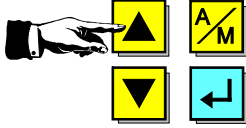
 <p>The digital controller indicates the sensor identification.</p>	 <p>If the sensor is connected for the first time or has been changed, the sensor identification has to be acknowledged by pressing any button.</p>
---	---



9.3.1 Controlling with the laser receiver LS 250

Procedure: Controlling with the laser receiver LS 250

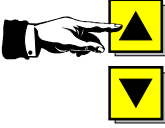
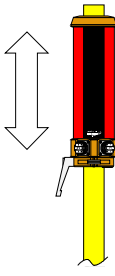
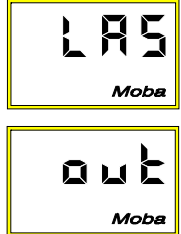
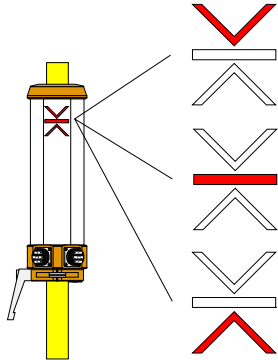
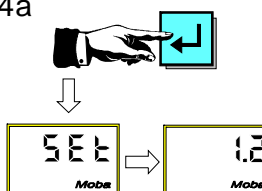
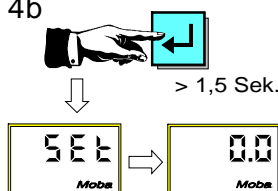
<p>1</p>  <p>Press the A/M-button to switch to the manual mode. The function lamp "AUTO" is off.</p>	<p>2</p>  <p>For zero setting, bring the tool into working position using the UP/DOWN-buttons at the controller or the operating unit at the machine.</p>	<p>3a</p>  <p>Now set the laser receiver so that the laser beam touches in the middle (observe the built in display.)</p>	<p>3b</p>  <p>If the laser beam does not touch the receiver window, the receiver has to be shift in height until one of the LEDs at the LS 250 lights up.</p>
<p>3c</p> <p>The laser receiver ...</p>  <ul style="list-style-type: none"> ... has to be moved down. ... is set up correctly. ... must be moved up. 		<p>4a</p>  <p>Now, the SET-button is pressed. If pressed for a short time, the display indicates "SET" and the actually measured value is stored as set point.</p>	<p>4b</p>  <p>If the SET-button is pressed for more than 1,5 seconds, the display changes from "SET" to "0.0" and the measured value and the set point are both set to zero.</p>

5



Switch over to the automatic mode with the A/M-button. The function lamp "AUTO" is on.



The controller keeps the tool at the adjusted value.

6

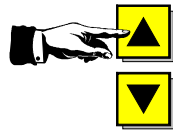

In order to be able to make corrections, the set point can be changed in the automatic mode using the UP/DOWN-buttons.

7



You can switch back to manual mode anytime with the A/M-button. The automatic control of the valves will then be switched off.



Adjustment and indication of the set point differ according to the selected operation mode (see also section 4.5 „Different user settings“).

Sensitivity

If the control works too sluggishly or too unstable in the automatic mode, the sensitivity should be changed accordingly. (see section 4.4.4 of these operating instructions).

Control window

The control window is active when the laser receiver LS 250 is in operation. The control window setting is described in section 4.4.5 of these operating instructions.

10. The Big-Ski

10.1 Description

The Big Ski is a grade or elevation sensing system that operates in many ways like the sonic ski. For this purpose, generally three sensors (e.g. 3x sonic skis, 2x dual sonics and one sonic ski or 3 dual sonics) are mounted to the Big Ski bracketry. The purpose of the Big Ski is to smooth the road and to control material costs.



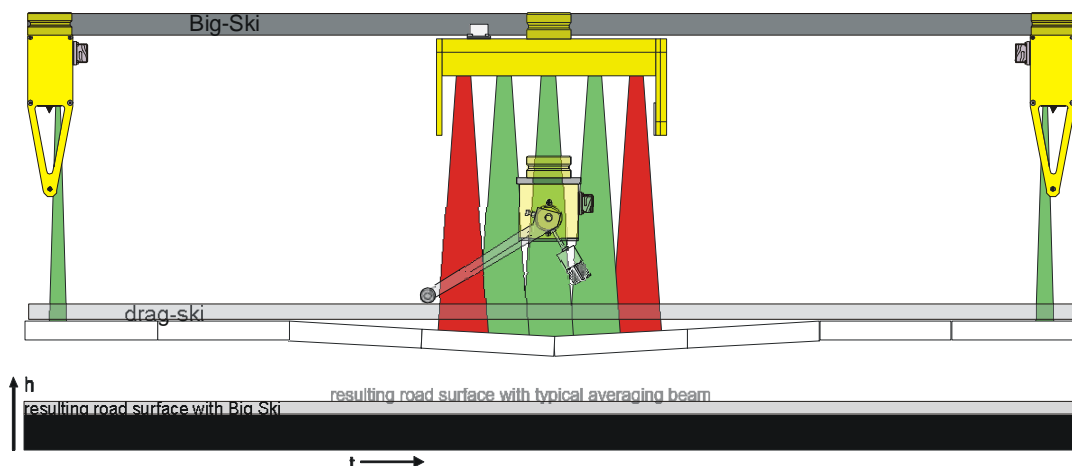

The length of the mounting system allows the Big Ski to produce a smoother mat because of its ability use both low and high points on the surface being smoothed. It does this by measuring the average elevation over its 30 foot span. Drag ski's simply bridge the high point's of the surface over which it spans. By averaging the high and low points of the surface that it spans the Big Ski will smooth the surface as well as reduce the quantity of the material. The MOBA non-contacting Big Ski measures more of the surface and therefore produces a smoother mat, and controls the average thickness of the mat much better than a contacting drag ski.

While there are many other situations for both the Big Ski and the drag ski than is shown in the diagram above, in most of them the Big Ski is the best solution for smoothing the road.

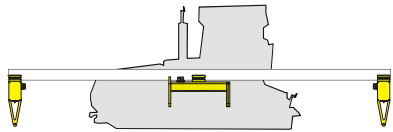

Sensor identification:

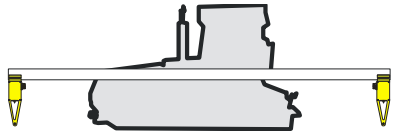
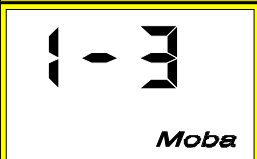
After the system is powered up or if a sensor has been changed, the controller display alternates between the numerical indication – figures 1 to 3 which stands for the sensors and “Sen”. If one of the sensors is not connected or if there bad cable to the sensor or a bad sensor the controller will indicate the bad sensor element as shown in the table below.

	=		
			

10.3.2 Electrical system

When working with machines that are prewired, the connection of 3 sensors in order to build a Big-Ski is no problem since appropriately coded connector plugs are provided at the front, in the middle and at the back of the machine side. The consecutive numbering, which the indication on the controller display refers to, is always done from the front to the back (in direction of travel).



Please only use Sonic-Ski or dual sonicsensors at positions 1 and 3 – i.e. at the front and the back.

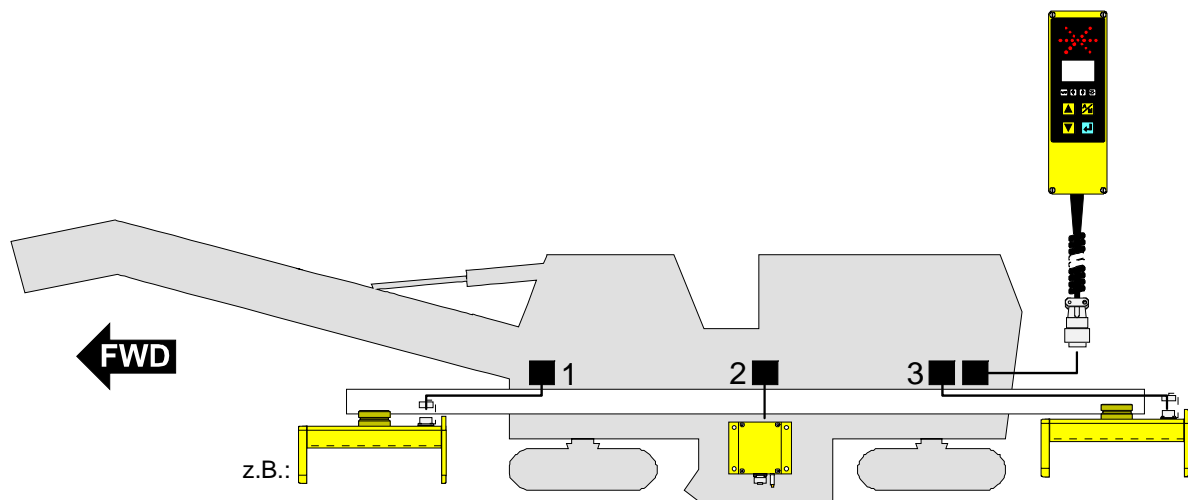

Connecting the Big-Ski to a global-version controller is not complicated.

In this case, the 3 sensors are connected to the controller by means of the “Big-Ski junction box“ with appropriately coded connector plugs.



The junction box should be mounted in a way that a simple wiring to the controller and the sensors is possible. The connectors for the sensors should always point downwards, so that no water can seep into the junction box. All inputs that are not used, should be sealed with dust protection caps.

Connect the digital controller with the input of the junction box. After that, connect the desired sensor combination to the outputs of the junction box as described below. The front sensor (as seen from direction of travel) is connected to output 1, the middle one to output 2 and the one at the back to output 3.

This order is the basis for the numerical indication on the controller display during sensor identification.



Please only use Sonic-Ski or dual sonic sensors at positions 1 and 3 – i.e. at the front and the back.

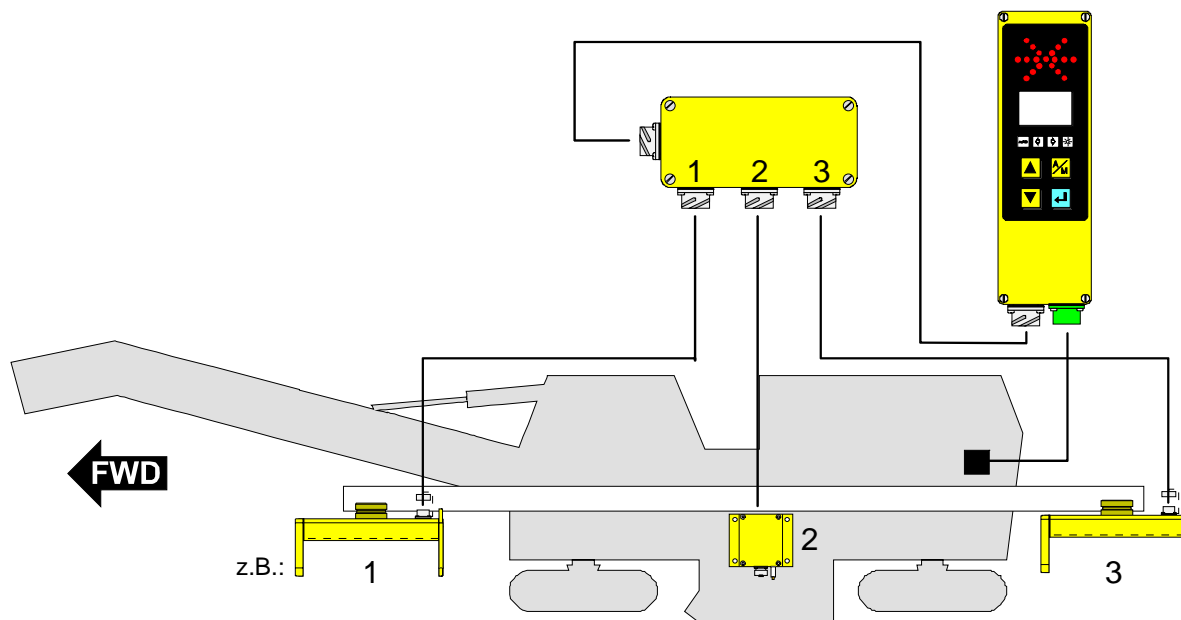

10.4 Set-up

With the Big-Ski, only ground sensing is possible.

Therefore, all Sonic-Skis have to work parallel to the direction of travel in order to obtain optimal results.

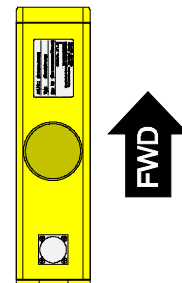

When working with the Big-Ski, the optimal working range of the Sonic-Ski has to be considered as well.

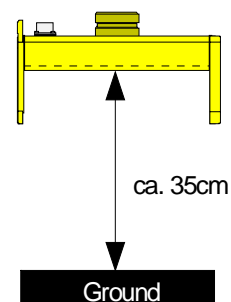

Each of the Sonic-Ski sensors used has to be positioned in a distance of 30 cm (11.75") to 40 cm (15.75") to the reference.



10.5 Working with the Big-Ski



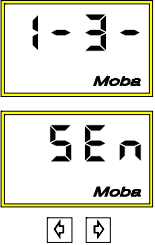
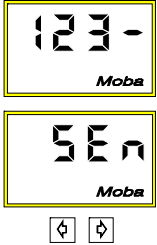

It is assumed that the Big-Ski and the digital controller are mounted, that all cables are connected and the digital controller has its voltage supply. After the switch-on message, the digital controller indicates the sensor identification. As soon as the message disappears, the system will be operable. If the Big-Ski is being used for the first time or the sensor combination has been changed, the sensor identification has to be acknowledged by pressing any one of the push buttons. If necessary, select a sensor as described in section 4.

Procedure: Acknowledgement of the sensor identification

<p>1a</p>  <p>The digital controller indicates the sensor identification (here: averaging of Sonic-Ski at the front and at the back).</p>	<p>1b</p>  <p>The digital controller indicates the sensor identification (here: averaging of 3 sensors).</p>	<p>2</p>  <p>If the Big-Ski is connected for the first time or the sensor combination has been changed, the sensor identification has to be acknowledged by pressing any button.</p>
---	--	--

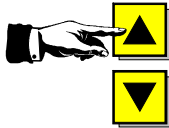
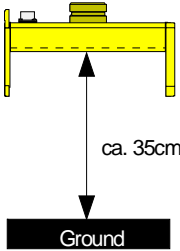
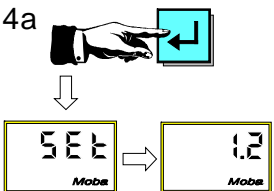
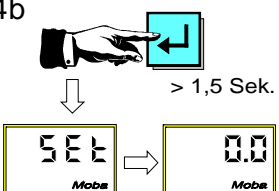
10.5.1 Controlling with the Big-Ski

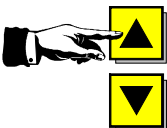
Procedure: Controlling with the Big-Ski

<p>1</p>  <p>Press the A/M-button to switch to the manual mode. The function lamp "AUTO" is off.</p>	<p>2</p>  <p>For zero setting, bring the tool into working position using the UP/DOWN-buttons at the controller or the operating unit at the machine.</p>	<p>3</p>  <p>Position all Sonic-Skis at a distance of 35cm (13.75") above the ground.</p>	<p>4a</p>  <p>Now, the SET-button is pressed. If pressed for a short time, the display indicates "SEt" and the actually measured value is stored as set point.</p>
<p>4b</p>  <p>If the SET-button is pressed for more than 1,5 seconds, the display changes from "SEt" to "0.0" and the measured value and the set point are both set to zero.</p>	<p>5</p>  <p>Switch to the automatic mode with the A/M-button. The function lamp "AUTO" is on.</p>  <p>The controller keeps the tool at the adjusted value.</p>	<p>6</p>  <p>In order to be able to make corrections, the set point can be changed in the automatic mode using the UP/DOWN-buttons.</p>	 <p>You can switch back to manual mode anytime with the A/M-button. The automatic control of the valves will then be switched off.</p>



Adjustment and indication of the set point differ according to the selected operation mode (see also section 4.5 "Different user settings").

Sensitivity

If the control is too sluggish or too active in the automatic mode, the sensitivity should be changed accordingly (see section 4.4.4 of these operating instructions).

Control window

The control window is active when the digital controller is operated with the Big-Ski. The setting of the control window is described in section 4.4.5 of these operating instructions.

11. Maintenance

11.1 General information

The MOBA-matic system has been developed for maximum operating safety. Maintenance is not time-consuming.

All electronic parts are mounted in durable housings in order to avoid mechanical damage.



However, the devices as well as all power supply- and connecting cables should be checked regularly with regard to possible damages or contamination from moisture or corrosion.



Please keep the threads of all plug-in connections and cable sleeves free of grease, dirt, asphalt and other debris in order to avoid bad connections.

11.2 How to clean the unit

Switch off the digital controller

- apply a normal washing-up detergent to a soft, lint free piece of cloth
- clean appliance surfaces and display(s) of the built-in indicator(s) without pressure
- remove the detergent from the appliances with a clean piece of cloth



Do not use detergents with abrasive substances to clean the displays. The surface will get scratches and will become hard to view.

12. Remedial measures in case of malfunction

12.1 General information

This chapter provides information on the measures you can take if an error occurs in the system.

In most cases, causes of trouble can be avoided by careful and timely maintenance. This helps to save money and inconvenience caused by unnecessary downtime.

Safety instructions:



- **Units as well as all accompanying components should only be opened in case of a reconfiguration and if particularly requested by the operating instructions!**
- **Defects should only be corrected by an authorized specialist!**
- **Don't rush when eliminating troubles!**
- **Please observe the rules for the prevention of accidents as well as all safety instructions!**

12.2 Fault indications and remedial measures

Fault indication	Fault diagnosis	Controller output	Action
no / 5En	Controller does not recognise a sensor.	Outputs inhibited in automatic mode.	<ul style="list-style-type: none"> • Connect sensor. • Check cable connections, change if necessary. • Change sensor.
SLo / out rky / out LAS / out -23 / out	Measured value of the active sensor out off the allowable range.	Outputs inhibited in automatic mode.	<ul style="list-style-type: none"> • Check sensor setting or check its direction. • Change sensor.
--- --- --- / ---3	Measured value of the active sensor out off the preset control window.	Outputs inhibited in automatic mode.	<ul style="list-style-type: none"> • Check sensor setting or check its direction. • Adjust sensor anew.
rop / dEF SLo / dEF	Controller detects a defective sensor.	Outputs inhibited in automatic mode.	<ul style="list-style-type: none"> • Check cable connections, change if necessary. • Change sensor.
E. 2	Data loss of the battery backed up memory.	Outputs inhibited in automatic mode.	<ul style="list-style-type: none"> • Acknowledge an alarm with any button. • Set working position again (zero- and setpoint).
E. 3 E. 4 E. 5	Data loss of the battery independently stored parameters.	Outputs inhibited in automatic mode.	<ul style="list-style-type: none"> • Acknowledge the alarm indication by pressing any button. The machine parameters will be set to their default values. If necessary set up again. • Set working position again (zero- and setpoint).

13. Technical data

On the following pages, you will find several data sheets for the most important components of this system.

Apart from a dimensional drawing, these data sheets also contain a description of the interfaces as well as some basic technical data.

The digital controller is available in 2 different versions.

The global version (2 appliance plugs in the housing) can be adapted to almost any machine with an electric tool control. The “pure“ CAN-version (with connector cable and only one connector plug) has been especially designed for machines which already have CAN-bus wiring.

The operation of the two controller types is absolutely identical.

As already mentioned in the beginning of these instructions, you can compose your own individual system which suits the requirements of the respective application. This means that you may not have acquired one or the other component described on the following pages.

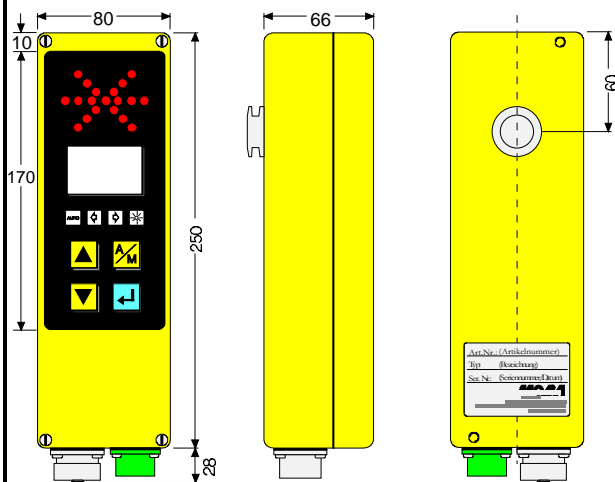
Dimensions:**Technical data:**

Voltage range:
11V ... 30V (DC)

Current consumption:
without valves

Allowable residual ripple:
+/- 10%

Power outputs:
ON/OFF, PNP/NPN, max. 3A
PROP, PNP, max. 2,5A

CAN-interface:
ISO 11898 - 24 V
125 kBit/sec

Ambient temperature range:
-10°C ... +70°C

Storage temperature range:
-25°C ... +85°C

Enclosure protection:
IP 67

Weight:
ca. 2,2kg

Pin connection:**Power interface**

12-pin plug, bayonet type jack
 A = Input "remote auto/manual"
 B = CAN-
 C = CAN+
 D = Input "machine side recognition"
 E = Input "Grade/Slope select"
 F = Output "alarm"
 G = n.c.
 H = n.c.
 J = Output "down"
 K = Output "up"
 L = +Supply voltage
 M = -Supply voltage

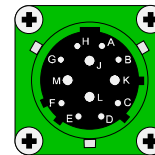
**Sensor interface**

7-socket receptacle; bayonet jack

A = + Supply voltage
 B = CAN+
 C = - Supply voltage
 E = digital I/O "Address1"
 F = n.c.
 G = Shield

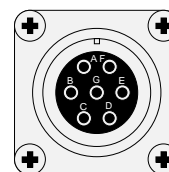
**Remark:**

Global-Version

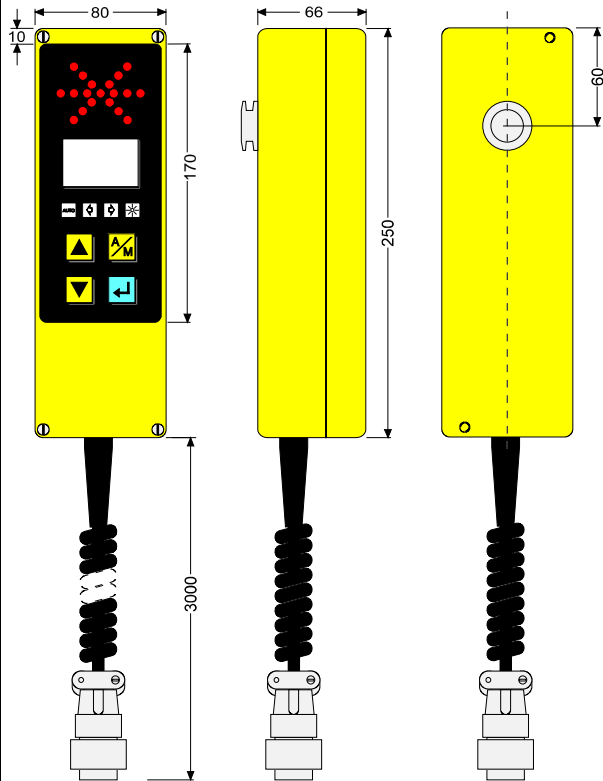
Dimensions:**Pin connection:****CAN-interface**

10pin cable connector, screwed connection

A = - supply voltage

B = + supply voltage

C = output "up"

D = output "down"

E = input "Grade/Slope select"

F = n.c.

G = input "machine side recognition"

H = CAN+

I = CAN-

J = input "remote auto/manual"

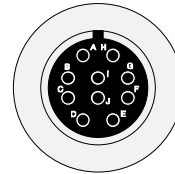
**Technical data:**

Voltage range:
11 V ... 30 V (DC)

Current consumption:
ca. 300 mA without valves

Allowable residual ripple:
+/- 10%

Power output:
ON/OFF, PNP/NPN, max. 3A
PROP, PNP, max. 2,5A
SERVO, max. 250mA

CAN-interface:
ISO 11898 – 24 V
125 kBit/sec

Ambient temperature range:
-10°C ... +70°C

Storage temperature range:
-25°C ... +85°C

Enclosure protection :
IP 67

Remark:

Version for CAN-wired machines

Switching logic of the 3 inputs of the MOBA-matic:

Input “Grade/Slope change-over”:

Pin E to Ground = Slope sensor

Pin E to +Bat. = Grade sensor

Pin E open (n.c.) = Grade sensor

Input “valve interruption”: *

Pin J to Ground = Stop of automatic

Pin J to +Bat. = Stop of automatic

Pin J open (n.c.) = Automatic free

Input “machine side recognition”:

Pin G to Ground = right

Pin G to +Bat. = left

Pin G open (n.c.) = left

* The logic of the input “valve interruption” can be changed via CAN configuration message or at the extended parameter menu of the controller.

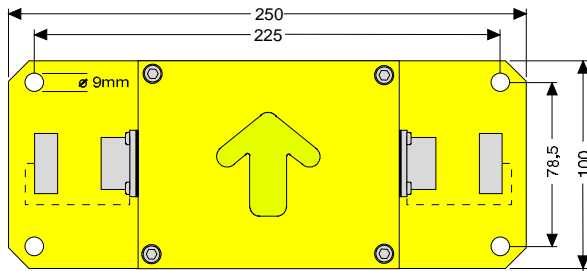
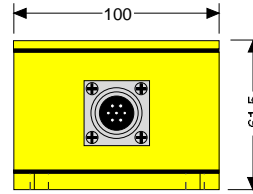
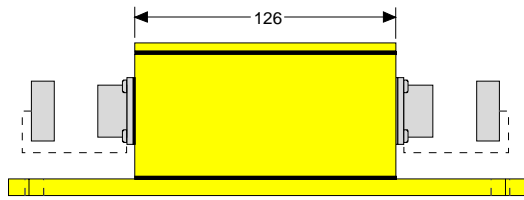
Abmessungen (Dimensions):**Technische Daten
(Technical data):**

Betriebsspannung (voltage range):
11V ... 30V (DC)

Stromaufnahme (current consumption):
max. 50 mA

Messbereich (measuring range):
+/- 10°

Interne Auflösung (internal resolution):
0,01%

Nullpunktstabilität (zero point stability):
0,1%

Arbeitstemperaturbereich (ambient temperature range):
-10°C ... +70°C

Lagertemperaturbereich (storage temperature range):
-25°C ... +80°C

Schutzart (enclosure protection):
IP 67

Gewicht (weight):
ca. 1,75 kg

Pinbelegung (Pin connection):**CAN-Schnittstelle (CAN-interface)
ISO 11898 - 24V - 125kBit/sec**

7pol. Gerätestecker; Bajonettverbindung
(7pin connectors; bayonet type connection)

- A = + Betriebsspannung (supply voltage)
- B = CAN+
- C = - Betriebsspannung (supply voltage)
- D = CAN-
- E = Adr.1
- F = Adr.2
- G = Schirm (shield)

Links (left):

- E = n.c.
- F = n.c.

Rechts (right):

- E = - Betriebsspannung (supply voltage)
- F = n.c.

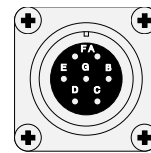
**Bemerkung (Remark):**

= neg. Neigung (neg. slope)

= pos. Neigung (pos. slope)

Abmessungen (Dimensions):

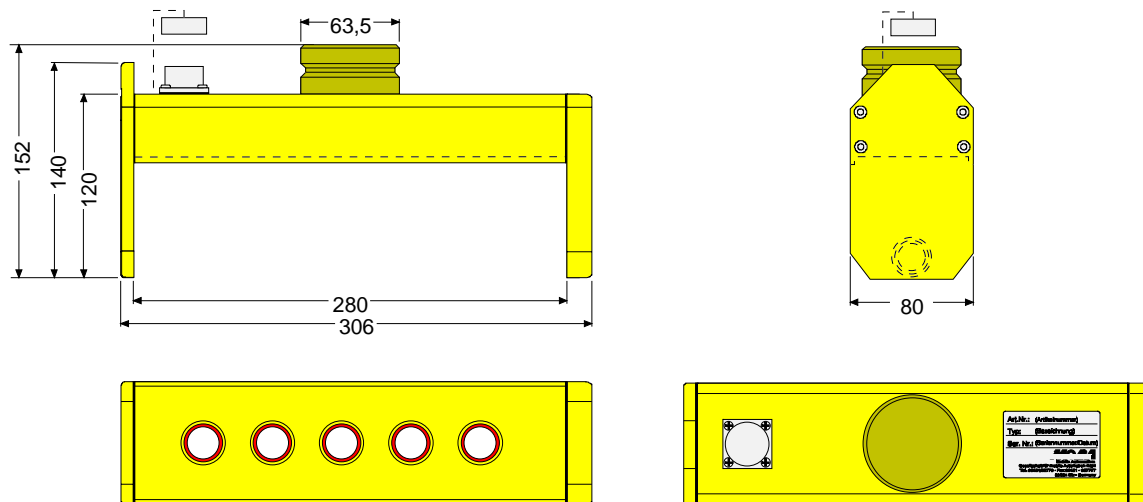

Technische Daten (Technical data):

Betriebsspannung (voltage range):
11 V ... 30 V (DC)

Stromaufnahme (current consumption):
Max. 300 mA

Zulässige Restwelligkeit (allowable residual ripple):
+/- 10%

Erfassungsbereich (measuring range)
20cm - 100cm

Reproduzierbarkeit (reproduceability):
+/- 1mm

Arbeitstemperaturbereich (ambient temperature range):
-10°C ... +70°C

Lagertemperaturbereich (storage temperature range):
-25°C ... +80°C

Schutzart (enclosure protection):
IP 67

Gewicht (weight):
ca. 2,3 kg

Pinbelegung (Pin connection):

CAN-Schnittstelle (CAN-interface) ISO 11898 - 24V - 125kBit/sec

7pol. Gerätestecker; Bajonettverbindung
(7pin connector; bayonet type connection)

- A = + Betriebsspannung (supply voltage)
- B = CAN+
- C = - Betriebsspannung (supply voltage)
- D = CAN-
- E = Adr.1
- F = Adr.2
- G = Schirm (shield)

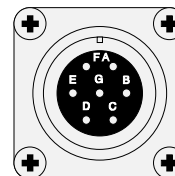

Bemerkung (Remark):

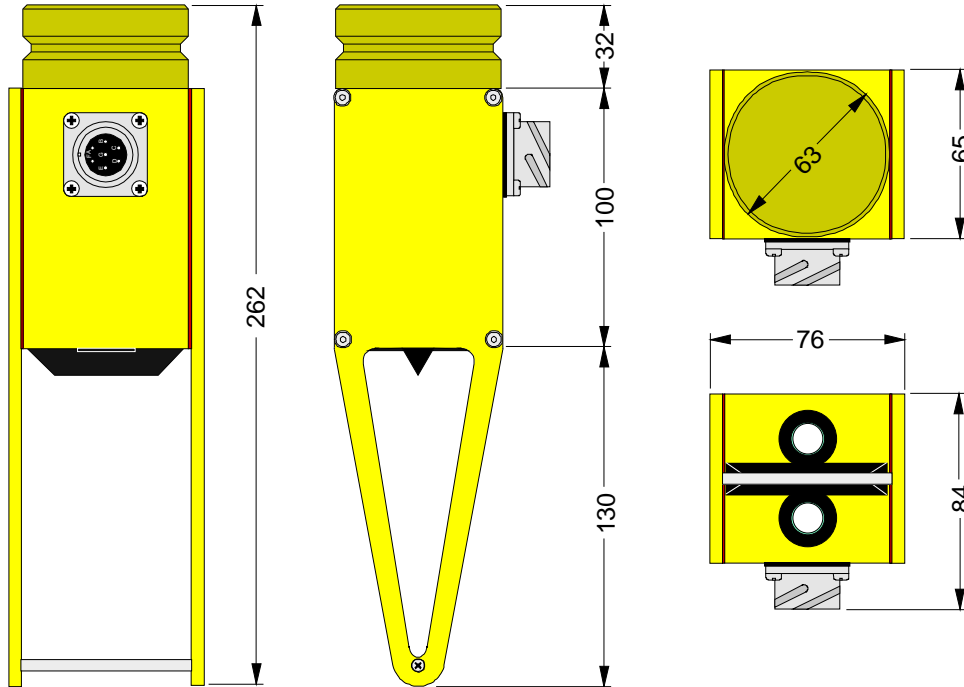
Abmessungen (Dimensions):**Technische Daten (Technical data):**

Betriebsspannung (voltage range):
10V ... 30V (DC)

Stromaufnahme (current consumption):
< 100mA @ 24V
< 200mA @ 12V

Meßbereich (measuring range):
20cm ... 100cm

Linearitätsabweichung (linearity deviation):
0,2% vom Endwert (full scale)

Offset (offset):
± 1mm

Temperaturabweichung im Bereich -25°C ... +85°C
(temperature deviation at the range -25°C ... +85°C)
max. ± 1% vom Messwert (of reading)

Arbeitstemperaturbereich (ambient temperature range):
-25°C ... +85°C

Lagertemperaturbereich (storage temperature range):
-25°C ... +85°C

Schutzart (enclosure protection):
IP 67

Pinbelegung (Pin connection):**CAN-Schnittstelle (CAN-interface)**

ISO 11898 - 24 V
125 kBit/sec

7pol. Gerätestecker; Bajonettverbindung
(7pin connector; bayonet type connection)

A = + Betriebsspannung (supply voltage)

B = CAN+

C = - Betriebsspannung (supply voltage)

D = CAN-

E = Adr. 1

F = Adr. 2

G = Schirm (shield)

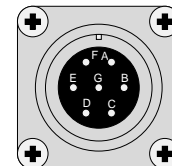
**Bemerkung (Remark):**

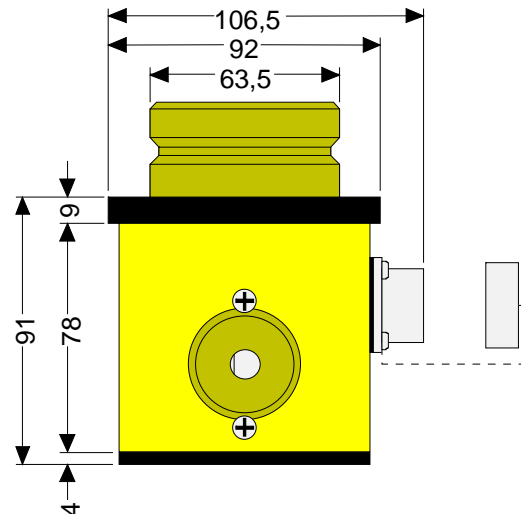
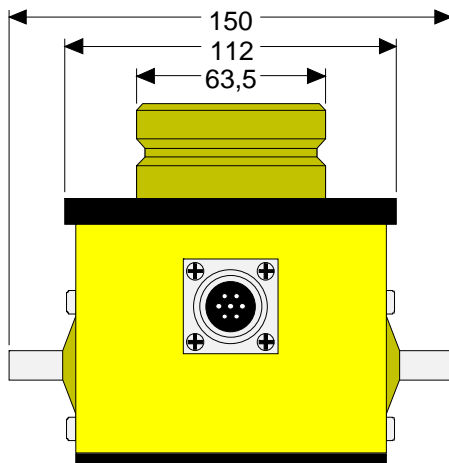
Abmessungen (Dimensions):**Technische Daten
(Technical data):**

Betriebsspannung (voltage range):
11V ... 30V (DC)

Stromaufnahme (current consumption):
Max. 50mA

Zulässige Restwelligkeit (allowable residual ripple):
+/- 10%

Erfassungsbereich (measuring range):
+/- 30°

Interne Auflösung (internal resolution):
0,1°

Reproduzierbarkeit (reproduceability):
+/- 0,1°

Arbeitstemperaturbereich (ambient temperature range):
-10°C ... +70°C

Lagertemperaturbereich (storage temperature range):
-25°C ... +80°C

Schutzart (enclosure protection):
IP 67

Gewicht (weight):
Ca. 1,1Kg

Pinbelegung (Pin connection):

CAN-Schnittstelle (CAN interface)
ISO 11898 - 24V; 125 kBits/sec

7pol. Verbinder; Bajonettverbindung
(7pin connector; bayonet type connection)

A = + Betriebsspannung (supply voltage)

B = CAN+

C = - Betriebsspannung (supply voltage)

D = CAN-

E = Adr.1

F = Adr.2

G = Schirm (shield)

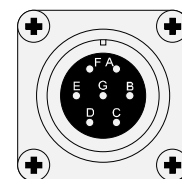
**Bemerkung (Remark):**

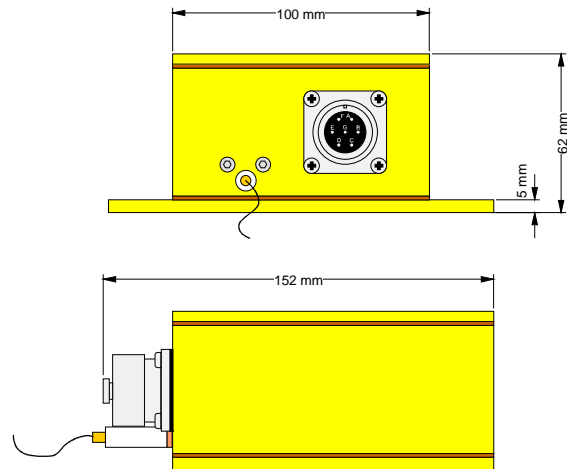
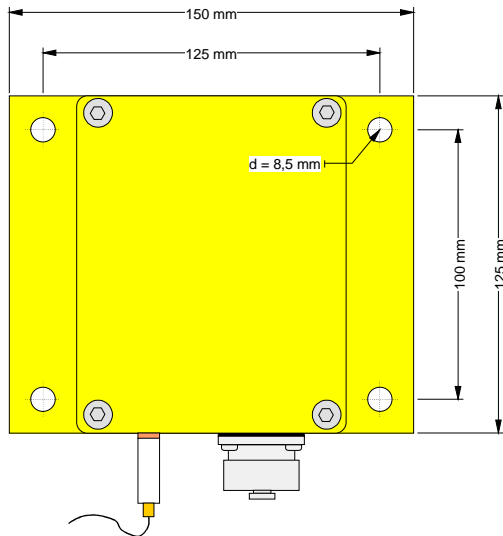
Abmessungen (Dimensions):**Technische Daten
(Technical data):**

Betriebsspannung (voltage range):
10 V ... 30 V (DC)

Stromaufnahme (current consumption):
< 200 mA

Messbereich (measuring range):
50 cm

CAN-Schnittstelle (CAN-interface):
ISO 11898 - 24 V;
125 kBit/sec.;

Arbeitstemperaturbereich (ambient temperature range):
-10°C ... +60°C

Lagertemperaturbereich (storage temperature range):
-25°C ... +75°C

Schutzart (enclosure protection):
IP 54

Gewicht (weight):
ca. 1,75 kg

Pinbelegung (Pin connection):

7pol. Gerüstestecker; Bajonettverbindung
(7pin plug; bayonet type connection)

- A = + Betriebsspannung (supply voltage)
- B = CAN +
- C = - Betriebsspannung (supply voltage)
- D = CAN -
- E = Adresse1 (address1)
- F = Adresse2 (address2)
- G = Schirm (shield)

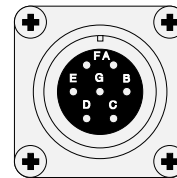
**Bemerkung (Remark):**

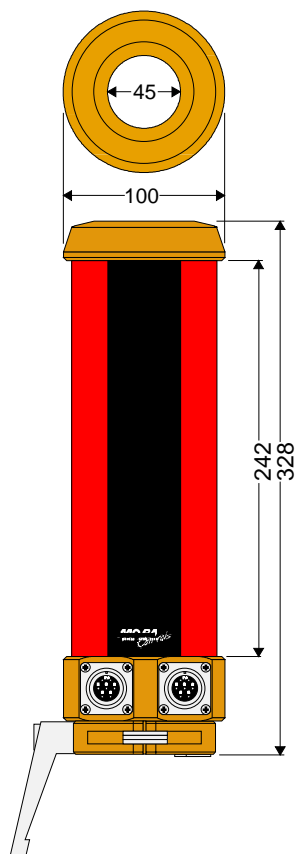
Abmessungen (Dimensions):**Technische Daten
(Technical data):**

Betriebsspannung (voltage range):
10 V ... 30 V (DC)

Stromaufnahme (current consumption):
ca. 200 mA

Messbereich (measuring range):
22 cm

Interne Auflösung (internal resolution):
0,1 mm

Wellenlänge (wavelength):
> 670 nm ... < 1000 nm

CAN-Schnittstelle (CAN-interface):
ISO 11898 - 24 V
125 kBit/sec

Pinbelegung (Pin connection):**PWM-Schnittstelle (PWM-interface)**

7pol. Gerätestecker; Schraubverbindung
(7pin connector; screwed connection)

A = + Betriebsspannung (supply voltage)
B = Sendesignal (send signal)
C = - Betriebsspannung (supply voltage)
D = Empfangssignal 1 (receive signal 1)
E = Sensorselektierung (sensor select)
F = Empfangssignal 2 (receive signal 2)
G = Schirm (shield)

CAN-Schnittstelle (CAN-interface)

7pol. Gerätestecker; Bajonettverbindung
(7pin connector; bayonet type connection)

A = + Betriebsspannung (supply voltage)
B = CAN+
C = - Betriebsspannung (supply voltage)
D = CAN-
E = n.c.
F = n.c.
G = Schirm (shield)

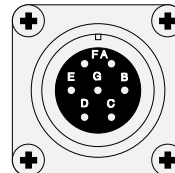

Arbeitstemperaturbereich
(ambient temperature range):
-10°C ... +70°C

Lagertemperaturbereich
(storage temperature range):
-25°C ... +85°C

Schutzart (enclosure protection):
IP 65

Bemerkung (Remark):

auch mit 75 cm Empfangsbereich lieferbar:
Bestell-Nr.: 04-60-11030;

(also available with 75 cm measuring range:
Order-No.: 04-60-11030);

14. Parameter menu

14.1 General information

All parameters have been factory preset to default values at the house of MOBA. With these defaults a sufficient operation of the most usual types of machines is ensured. Nevertheless it is recommended to optimize each system by adjusting its parameters depending on the specific conditions of the machine.

The parameter settings can be done in manual mode as well as in automatic mode. So the user has got the possibility to optimize his system while working.

If any button is pressed while the starting message is indicated, the software version appears on the display for about 4 seconds.

In this manual we will not separately deal with the working menu of the MOBA-matic. For informations and instructions concerning the working menu please see the operating instruction.

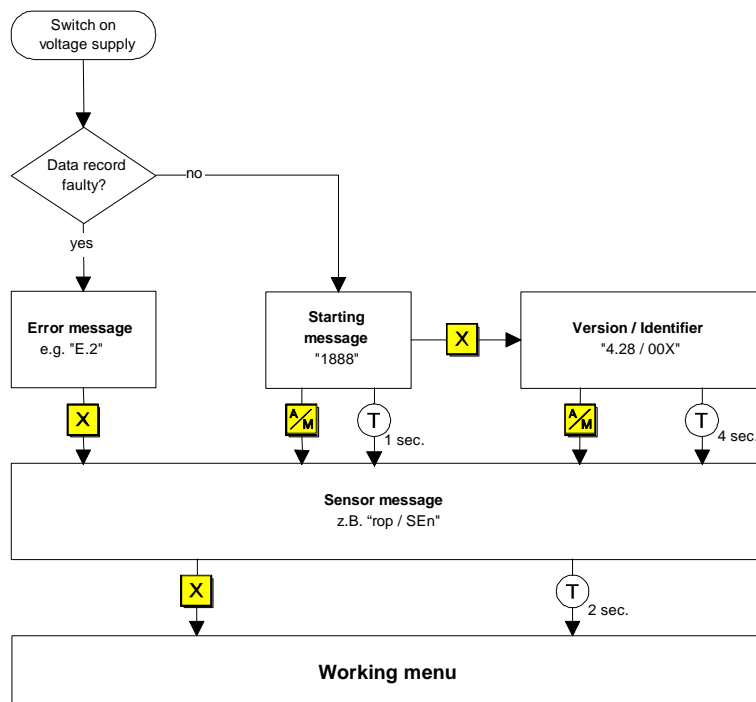

14.2 Operator menu

14.2.1 Operator menu access

The operator menu can be accessed from the working menu only.



To access the first parameter press the A/M button and the ENTER buttons at the same time.



Use this button combination to switch from one parameter to the next.

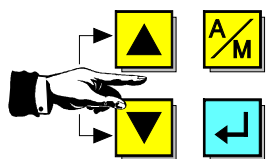

By pressing the UP button or the DOWN button parameter values are set or function modes are changed.



The operator menu can be exited any time by pressing the A/M button.



If no button is pressed for about 5 seconds the controller automatically switches back to the working menu.

14.2.2 Operator menu diagram

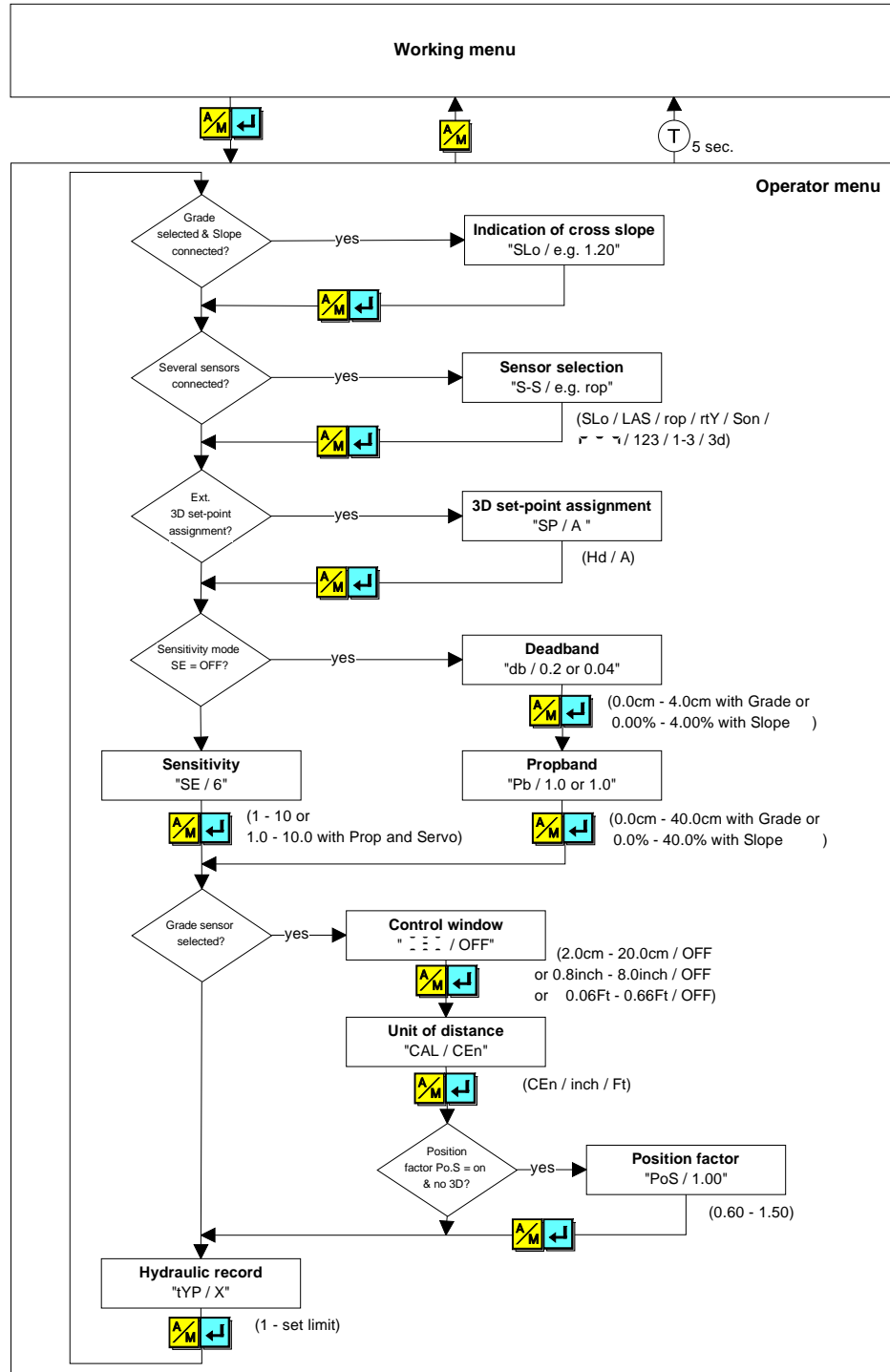

14.2.3 Operator menu description of parameters

Parameter	Sign	Default	Range	Description
Indication of cross slope	SLa		Measuring range of the cross slope sensor	If a slope sensor is connected to the CAN bus and a grade sensor is selected as active sensor for the controller, the actual measured slope of the tool is indicated here.
Sensor selection	S-5		SLa, LRS, rOP, rEY, Son, IZJ, I-3, 3d etc.	Parameter appears only if more than one MOBA-matic sensor is connected to the CAN bus. In this case the selection of the active sensor is done here. For the meaning of the abbreviations please see the MOBA-matic operating instructions.
3D set-point assignment	SP	A	A or Hd ;	If the controller receives external 3D set-point assignments you can choose whether this shall be used for the controlling or whether the controlling is to be made via manual inputs at the push buttons of the controller. A = automatic = 3d controlling; Hd = manual mode = Controlling is made via push button inputs;
Sensitivity	SE	b	1 - 10 or 1.0 - 10.0 with Prop and Servo valves;	Sensor sensitivity adjustment. An increase of this value means that the controlling happens faster and it is tried to get a closer result to the adjusted setpoint.
Deadband	db	0.2 or 0.04	0.0-4.0 cm for grade sensors; 0.00-4.00% for slope sensors;	Range around the operating point in which no valve drive is done. Comparable with an accuracy tolerance.
Propband	Pb	1.0 or 1.0	0.0-40.0 cm for grade sensors; 0.0-40.0% for slope sensors;	Range above and underneath the Deadband where a defined valve drive, depending on the deviation to the operating point, is done. The shortest pulse is set as Min. pulse or Min. current, the longest one is made up of Min. pulse + Delta max. pulse or is set as Max. current. The pulse-times between Min. and Max. are interpolated over the range of the Propband.
Control window	▲▲▲ ▼▼▼	OFF	2.0 - 20.0 cm; 0.8 - 8.0 inch; 0.0b - 0.6 b Ft; or OFF ;	The automatic control of the valves is switched off and the sign of the control window is indicated, if a deviation appears that is bigger than the value set here. This parameter can be deactivated by increasing the value until „OFF“ is indicated.

Parameter	Signl	Default	Range	Description
Unit of distance	LEN	LEN	LEN, Inch or FEET	Physical unit for all distance measurements: LEN = Centimeter; Inch = Inch; FEET = Feet;
Position factor	POS	1.00	0.60 to 1.50	If the change of height at a sensor is unequal to the change of height of the tool of the machine which is to be controlled then the position factor can make the changes equal.
Hydraulic record	LYP	1	1 – set limit (see also „Limit hydraulic type“ at the extended parameter menu);	Settings for different machines can be stored under the positions 1 to X, in case that the controller is used on several machines with hydraulic actions that differ from each other.

14.3 Basic parameter menu

14.3.1 Basic parameter menu access

The standard parameter menu can be accessed from the operators menu.

To access the operator menu press the A/M button and the ENTER button at the same time.

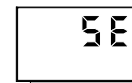

Then press and hold on the ENTER button for 3 seconds until "PA" is indicated. When "PA" appears in the display then release the ENTER button.



Hold on for 3 seconds



Within the next 3 seconds the following button sequence must be pressed:

- 1) – ENTER button
- 2) – DOWN button
- 3) – UP button



The operator menu can be exited any time by pressing the A/M button.



Change from one parameter to the next by pressing the ENTER button.



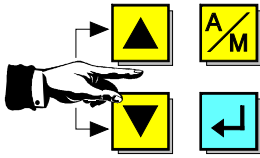

By pressing the UP or DOWN button parameter values are set or function modes are changed.

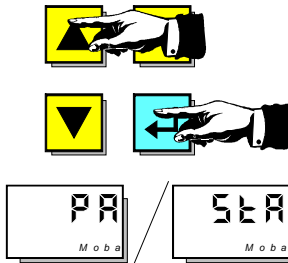

If the controller is in the standard parameter menu and the UP button and the ENTER button are pressed at the same time until the display indicates "PA"/"StA", all parameters are set to their default values.



The controlling of the valves with the adjusted pulses or currents can be tested immediately in the standard parameter menu.

(Procedure see menu diagram 3.2)



14.3.2 Parameter menu diagram

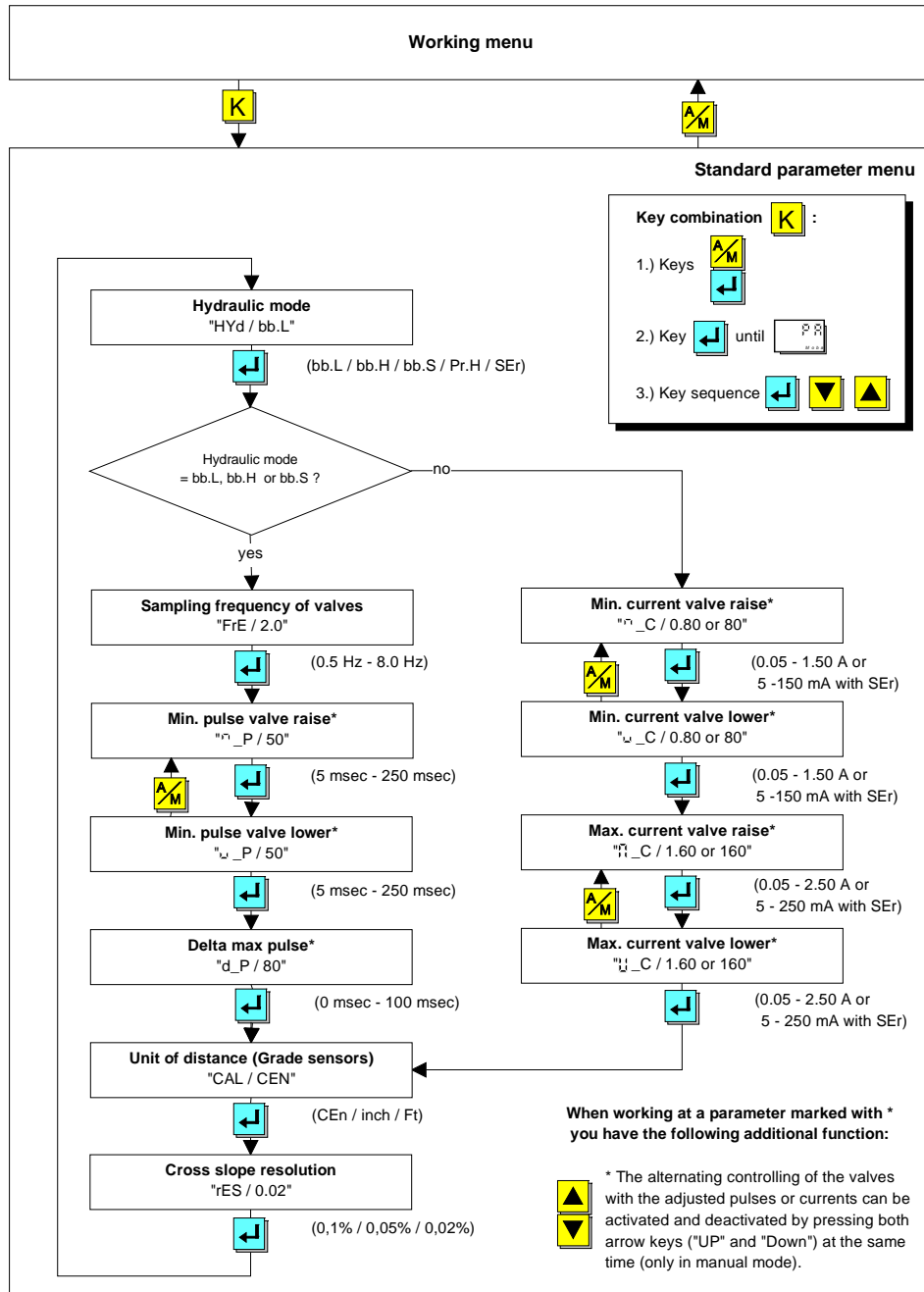

If the keys are pressed simultaneous until the display indicates
(at the parameter menu), all parameters are set to their default values.

14.3.3 Basic menu description of parameters

Parameter	Sign	Default	Range	Description
Hydraulic Mode	<i>Hyd</i>	<i>bb.L</i>	<i>bb.L</i> , <i>bb.H</i> , <i>bb.S</i> , <i>Pr.H</i> or <i>SEr</i>	Type and drive technique of the valves: <i>bb.L</i> = On/Off valve, minus switching <i>bb.H</i> = On/Off valve, plus switching <i>bb.S</i> = Servo valve in switching mode <i>Pr.H</i> = Prop. valves, plus switching <i>SEr</i> = Servo valves
Sampling frequency of valves	<i>FrE</i>	<i>2.0</i>	<i>0.5 - 8.0</i>	Parameter <u>for On/Off valves and servo valves in switching mode only</u> Frequency for the valve drive within Propband.
Min. pulse of valve raise	<i>n_P</i>	<i>50</i>	<i>5 - 250</i>	Parameter <u>for On/Off valves and servo valves in switching mode only</u> Shortest time that is to be used for the drive of the valve raise, when the deviation is within Propband = defines the lowest possible cylinder speed.
Min. pulse of valve lower	<i>u_P</i>	<i>50</i>	<i>5 - 250</i>	Parameter <u>for On/Off valves and servo valves in switching mode only</u> Shortest time that is to be used for the drive of the valve lower, when the deviation is within Propband = defines the lowest possible cylinder speed.
Delta max pulse	<i>d_P</i>	<i>80</i>	<i>0 - 100</i>	Parameter <u>for On/Off valves and servo valves in switching mode only</u> The sum of Min. pulse raise or lower and the time that is set here results in the Max. pulse (highest allowed cylinder speed) for the valve drive within Propband. The pulse-times between Min. and Max. are interpolated over the range of the Propband.
Min. current of valve raise	<i>n_C</i>	<i>0.80</i> or <i>80</i> with Servo	<i>0.05 to 1.50</i> or <i>5 to 150</i> with Servo;	Parameter <u>for proportional valves and servo valves only.</u> Lowest current that is to be used for the drive of the valve raise = defines the lowest possible cylinder speed.
Min. current of valve lower	<i>u_C</i>	<i>0.80</i> or <i>80</i> with Servo	<i>0.05 to 1.50</i> or <i>5 to 150</i> with Servo;	Parameter <u>for proportional valves and servo valves only.</u> Lowest current that is to be used for the drive of the valve lower = defines the lowest possible cylinder speed.
Max. current of valve raise	<i>n_C</i>	<i>1.60</i> or <i>160</i> with Servo	<i>0.05 - 2.50</i> or <i>5 - 250</i> with Servo;	Parameter <u>for proportional valves and servo valves only.</u> Highest current that is to be used for the drive of the valve raise = defines the highest allowed cylinder speed.

Parameter	Sign	Default	Range	Description
Max. current of valve lower	<code>U_C</code>	<code>1.60</code> or <code>1.60</code> with Servo	<code>0.05</code> - <code>2.50</code> or <code>5</code> - <code>250</code> with Servo;	Parameter for proportional valves and servo valves only. Highest current that is to be used for the drive of the valve lower = defines the highest allowed cylinder speed.
Unit of distance	<code>CAL</code>	<code>CEn</code>	<code>CEn</code> , <code>Inch</code> or <code>Fe</code>	Physical unit for all distance measurements: <code>CEn</code> = Centimeter; <code>Inch</code> = Inch; <code>Fe</code> = Feet;
Cross slope resolution	<code>rES</code>	<code>0.02</code>	<code>0.1</code> , <code>0.05</code> or <code>0.02</code>	Displayed resolution of the cross slope: <code>0.1</code> = 1/10%; <code>0.05</code> = 5/100%; <code>0.02</code> = 2/100%;

14.4 Extended parameter menu

14.4.1 Extended parameter menu access

The extended parameter menu can be accessed from the working menu only.



Access the operator menu by pressing the A/M button and the ENTER button at the same time.



Hold on for 3 seconds.



Hold on the ENTER button for 3 seconds until "PA" is indicated.



Within the next 3 seconds the button sequence:

1) - ENTER button

2) - DOWN button

3) - UP button

has to be pressed.



Hold on for 5 seconds.



Now hold the ENTER button pressed for about 5 seconds until "SES" appears in the display.

The operator menu can be left any time by pressing the A/M button.



To change from one parameter to the next press the ENTER button.



By pressing the UP button or the DOWN button parameter values are set or function modes are changed.

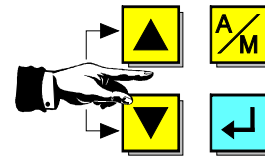

If the controller is in the extended parameter menu and the UP button and the ENTER button are pressed at the same time until the display indicates "PA"/"StA", all parameters are set to their default values.

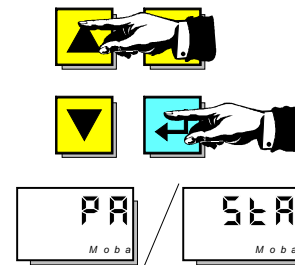

The controlling of the valves with the adjusted pulses or currents can be tested immediately in the extended parameter menu.

(Procedure see menu diagram 4.2)



If the sensitivity mode is deactivated in the extended parameter menu, the operator menu changes.

(See sections 2.2 and 2.3 of these instructions)



14.4.2 Extended parameter menu diagram

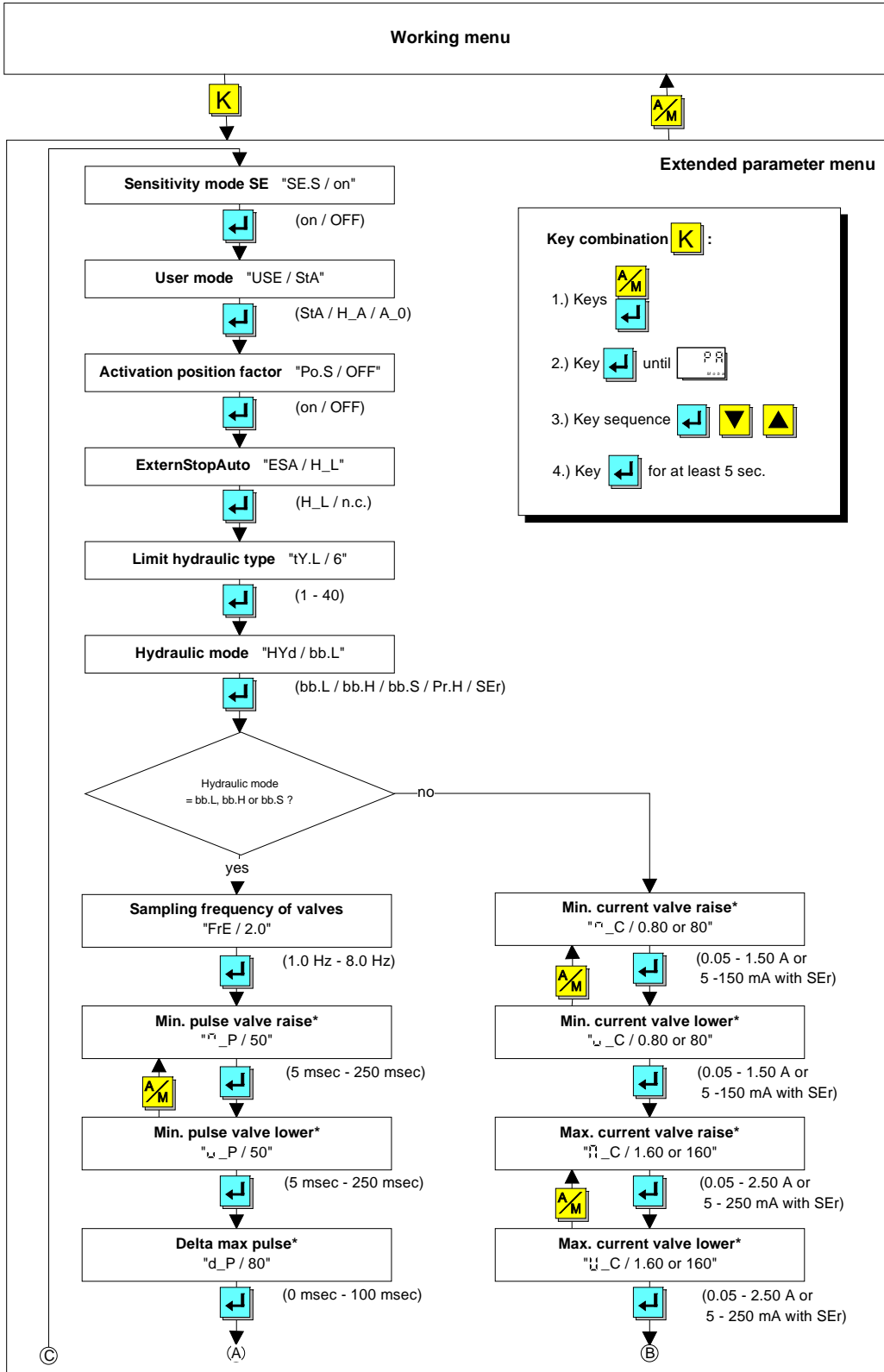

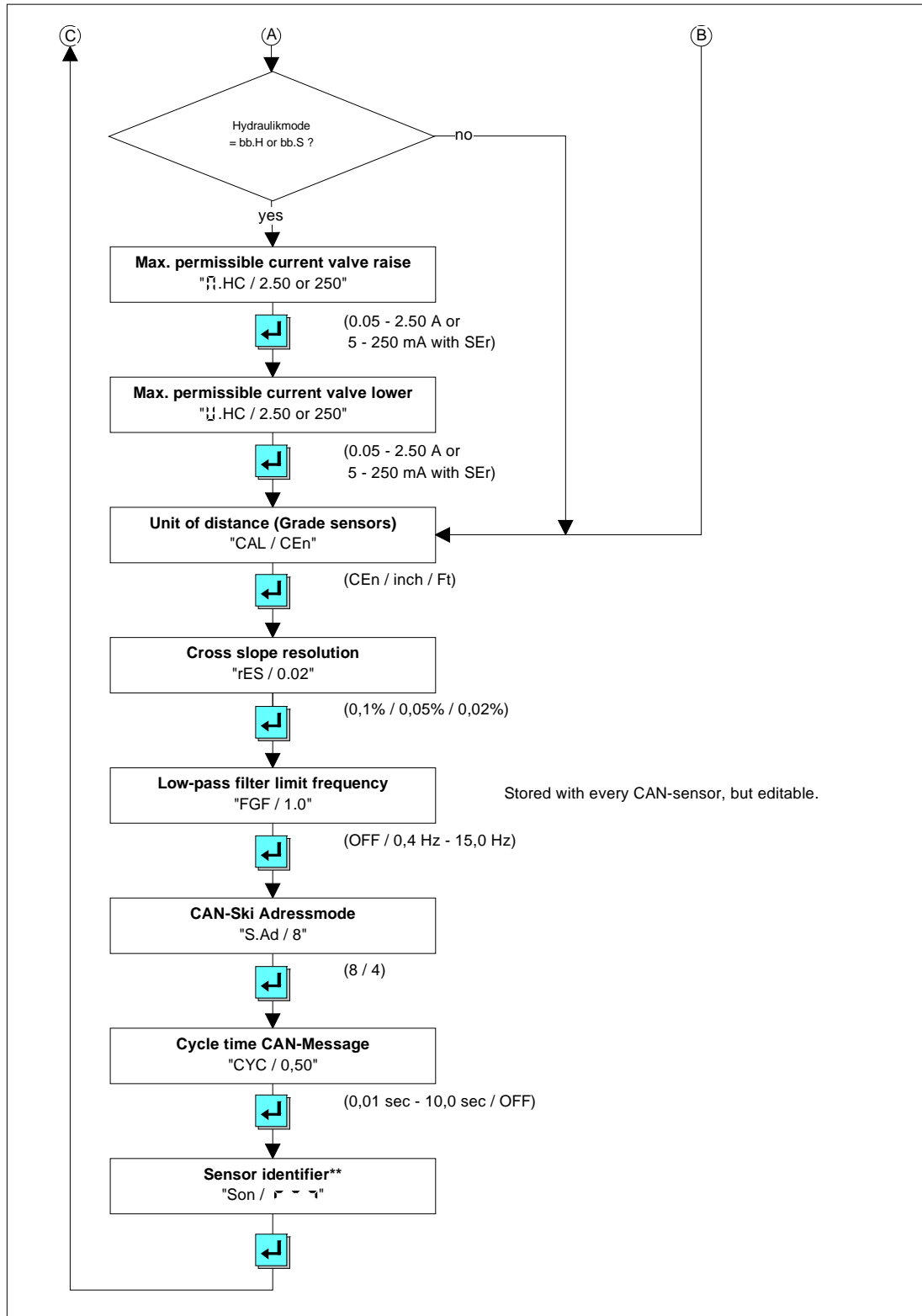

**Max. pulse valve raise or lower =
Min. pulse valve raise or lower + Delta max pulse**

If you are working at a parameter marked with * or ** you have the following additional functions:

* = By pressing both arrow buttons (“Up” and “Down”) at the same time the alternating controlling of the valves with the adjusted pulses or currents can be activated and deactivated (only in manual mode).

** = By pressing the Up-button and the Down-button the measured value of each sensorhead of the Sonic-Ski sensor will be indicated separately. These values are without compensation of running time and correspond to 1 mm.

14.4.3 Extended menu description of parameters

Parameter	Sign	Default	Range	Description
Sensitivity SE	SES	on	on or OFF;	Select "SE" (Sensitivity) or "DB" (Deadband); "PB" (Proportional Band) for adjustment from the operators menu on = Sensitivity setting from prestored values; OFF = Deadband and Propband can be set directly - operator menu has changed.
User mode	USE	StA	StA, H_A or A_O;	The operator has the opportunity to choose from 3 different variants of operation (see also the operation instructions): StA = Operating modes Manual & Automatic; set-point adjustment takes place in 1mm steps (with quick adjustment); when changing the set-point the new numerical value is indicated at the display; H_A = Divergent to StA there is additional the operating mode half automatic (set-point adjustment takes place with deactivated controller outputs); A_0 = Divergent to StA the set-point adjustment takes place in 2mm steps (every time the button is pressed anew); when changing the set-point the new adjusted numerical value is automatically taken over as zero point, and indicated „0.0“ at the display, after about 5 seconds;
Activation position factor	Po.S	OFF	on or OFF;	Enables the "position factor" to be accessed from the operators menu. on = Position factor can be set; OFF = Position factor can <u>not</u> be set
ExternStopAuto	ESA	H_L	H_L or n.c.	Sets the voltage level that has to be fed to pin J of the connection plug to stop the "Auto"-function of the controller (emergency switch). H_L = StopAuto with high or low level; n.c. = StopAuto with pin J open (high-resistance input);
Limit Hydraulic type	tY.L	6	1 - 40	Sets the maximum number of programmable and selectable hydraulic records (see operator menu).

Parameter	Sign	Default	Range	Description
Hydraulic mode	HYd	bb.L	bb.L, bb.H, bb.S, Pr.H or SEr;	Type and drive technique of the connected valves: bb.L = On/Off valve, minus switching bb.H = On/Off valve, plus switching bb.S = Servo valve in switching mode Pr.H = Prop. valves, plus switching SEr = Servo valves
Sampling frequency of valves	FrE	2.0	0.5 - 8.0Hz;	Parameter <u>for On/Off valves and servo valves in switching mode only</u> Frequency for the valve drive within Propband.
Min. pulse of valve raise	r_P	50	5 - 250msec;	Parameter <u>for On/Off valves and servo valves in switching mode only</u> Shortest time that is to be used for the drive of the valve raise, when the deviation is within Propband = defines the lowest possible cylinder speed.
Min. pulse of valve lower	l_P	50	5 - 250msec;	Parameter <u>for On/Off valves and servo valves in switching mode only</u> Shortest time that is to be used for the drive of the valve lower, when the deviation is within Propband = defines the lowest possible cylinder speed.
Delta max pulse	d_P	80	0 - 100msec	Parameter <u>for On/Off valves and servo valves in switching mode only</u> The sum of Min. pulse raise or lower and the time that is set here results in the Max. pulse (highest allowed cylinder speed) for the valve drive within Propband. The pulse-times between Min. and Max. are interpolated over the range of the Propband.
Min. current of valve raise	r_C	0.80 or 80 with Servo	0.05 - 1.50A; or 5 - 150mA with Servo;	Parameter <u>for proportional valves and servo valves only.</u> Lowest current that is to be used for the drive of the valve raise = defines the lowest possible cylinder speed.
Min. current of valve lower	l_C	0.80 or 80 with Servo	0.05 - 1.50A; or 5 - 150mA with Servo;	Parameter <u>for proportional valves and servo valves only.</u> Lowest current that is to be used for the drive of the valve lower = defines the lowest possible cylinder speed.
Max. current of valve raise	R_C	1.60 or 160 with Servo	0.05 - 2.50A; or 5 - 250mA with Servo;	Parameter <u>for proportional valves and servo valves only.</u> Highest current that is to be used for the drive of the valve raise = defines the highest allowed cylinder speed.
Max. current of valve lower	L_C	1.60 or 160 with Servo	0.05 - 2.50A; or 5 - 250mA with Servo;	Parameter <u>for proportional valves and servo valves only.</u> Highest current that is to be used for the drive of the valve lower = defines the highest allowed cylinder speed.

Parameter	Sign	Default	Range	Description
Parameter	Sign	Default	Range	Description
Max. permissible current of valve raise	↕.HC	2.50 or 250 with Servo	0.05 - 2.50A; or 5 - 250mA with Servo;	Parameter for On/Off valves (plus switching) and Servo valves in switching mode only. Highest permissible current that may flow during the drive of the valve raise.
Max. permissible current of valve lower	↕.HC	2.50 or 250 with Servo	0.05 - 2.50A; or 5 - 250mA with Servo;	Parameter for On/Off valves (plus switching) and Servo valves in switching mode only. Highest permissible current that may flow during the drive of the valve lower.
Unit of distance	CAL	CEn	CEn, inch or Ft;	Physical unit for all distance measurements: CEn = Centimeter; inch = Inch; Ft = Feet;
Slope resolution	rES	0.02	0.1, 0.05 or 0.02;	Displayed resolution of the cross slope: 0.1 = 1/10% 0.05 = 5/100% 0.02 = 2/100%
Low-pass filter limit frequency	FGF	1.0	0.4 - 15.0Hz or OFF	Low-pass filter of 2nd order; Value is stored in each CAN sensor. Can be edited.
CAN-Ski Adressmode	S.Ad	8	8 or 4;	8 (new adresssing) = 2 MOBA-matic controllers with 4 sensors each can operate in one CAN-network; 4 (old adresssing) = only in order to ensure the downward compatibility to old Ski models and old Big-Ski junctionboxes.
Cycle time CAN-Message	CYC	0,10	0.01 – 10.0sec or OFF	Time interval that is used by the MOBA-matic to send the control-relevant parameters (Actual value, setpoint etc.) onto the CAN-bus.
Sensor identifier				The current connected type of sensor is detected. If the Sonic-Ski sensor is connected the distance of each sensorhead can be checked separately.

15. Controller set up examples

15.1 Steps to program a controller for a paver

Program the correct hydraulic type for your machine and make sure that depressing the up arrow on the controller will move the cylinder up and depressing the down arrow will move the cylinder down.

Note. If the Tow Point Cylinder will not move then take the following steps:

The default value of the controller for the valve current may need to be increased for the tow-point to move.

Make sure that there is not a cylinder shut off that is closed.

Double-check the Hydraulic setting of the controller to match the machine.

Note. If your machines raise and lower are backward then take the following step:

By swapping the connectors at the valve you will change the raise and lower.

With the above steps complete and you can raise and lower the Tow-Point Cylinder you can now start to program the valve speeds of the machine.

Steps to setting Valve Speeds:

1. Enter the Technicians menu of the controller and go to the Min Up value. Refer to page two for this procedure.

The standard parameter menu can be called up from the working menu only.

Therefore:

First switch over to the operator menu by pressing the A/M key and the ENTER key at the same time.



Hold on the ENTER key for 3 seconds until „PA“ is indicated.



Hold on for 3 seconds



Within the next 3 seconds the key sequence:

- 1) – ENTER key
 - 2) – DOWN key
 - 3) – UP key
- has to be pressed.

**Note.**

After step 3 is complete you will see HYD in the Display. By depressing the blue button you will go to the Min Up symbol.

(\overline{M} \overline{U}) **Min UP Current**

(\overline{M} \overline{D}) **Min DOWN Current**

(\overline{M} \overline{U}) **Max UP Current**

(\overline{M} \overline{D}) **Max DOWN Current**

2. With the Min Up value in the display, lower this down to its lowest number. Then depress the blue button once and it will go to the Min Down value and lower this number as well. After this is complete depress the A/M button until you are at the working display.
3. Lower the Screed and set it on a pipe that is going perpendicular with the machine. This pipe should be no smaller than 1.5". By doing this step you have now made the screed so that it will pivot on the pipe and not be bound up at any point on the ground.
4. Connect a grade sensor to the end-gate or tow-arm, center the towpoint and set your sensor height to 14".
5. Zero your sensor by depressing the Blue button on the controller and the display should read 0.0
6. Put the controller in automatic by depressing the A/M button. At this time you should have 0.0 in the display and the Automatic light should be illuminated.
7. Depress the up arrow two times until the display reads 0.2. At this time you should have a flashing up arrow with the tow-point cylinder **Not Moving Up.**
8. While the controller is in **Automatic**, enter the Technicians menu and go to the Min up value and raise the number slowly until the machine goes to grade.
 - a. At this time you should still have Min Up in the display and you can now depress the Blue button and go to the Min Down value.
9. By using the manual switch for the tow-point cylinder, just bump the switch to make the cylinder go up and the Controller will flash a down arrow.
10. Increase the Min Down value slowly until the machine moves to grade and stops.
11. Jog the manual switch up and it should come to grade. Jog the manual switch down and the machine should come to grade. If it still flashes a little then just increase the current value one or two until it goes to grade and repeat this step.

Adjusting the Max Up and Max Down.

Note.

For Machines with **On / Off Valves** you will not have Max Up or Max Down you will however find in the bottom menu a setting for **Delta Pulse or (dp)**.

- a. Delta pulse is a combined number for max up and max down.
- b. The number that is displayed can be lowered to slow the large correction or raised to speed up a large response.
- c. The default value of **80** is generally fine for most applications.
- d. At this point your machine should be set-up and you can check the response by dialing the controller up 1.5" and then down 1.5". Your tow-point should go to grade and stop without any Over Shooting.
- e. After checking the response set-up is complete and you should proceed to step 14.

Note.

For machines with **Proportional valves** a good starting point for Max Current is to add 20 - 30 to the Min current for example, if you have a Min Up value of 20 then you would set your Max UP to 40 - 50.

After confirming steps 3,4,5 and 6 proceed to the next step.

12. With the down arrow on the controller depressed, take the value down to -1.5" and the tow-point should go down and stop.

- a. If it is too slow, go to the Technicians Menu, refer to the Max Down value and add another 5 to 10 and repeat until its the speed you want.
- b. If it is too fast then drop your numbers another 5 to 10 and repeat the step.
- c. Once the Down side is good, proceed to 13.

13. With the Up arrow on the controller depressed, take the value down to 1.5" and the tow-point should go UP and stop.

- a. If it is too slow, go to the Technicians Menu, refer to the Max Up value and add another 5 to 10 and repeat until its the speed you want.
- b. If it is too fast then drop your numbers another 5 to 10 and repeat the step.
- c. Once the Up side is good, proceed to the next step.

14. With the above steps complete you are ready to get the machine on the road. A great help in knowing that you have tuned this machine correctly is watching the lights on the controller while your paving.

- a. You should see the **On Grade Symbol** most of the time **with a flashing up or down arrow** from time to time.
- b. If you see a lot of **flashing** in one direction or both then leave it in Automatic, go to the Technicians menu and adjust your Min up or Min down 1 – 2 and see if this helps.
- c. After your changes depress the A/M button and return to the working display keeping in mind that the **Automatic light should still be illuminated.**

15.2 Steps to program a controller for a mill

Program the correct hydraulic type for your machine and make sure that depressing the up arrow on the controller will move the machine up and depressing the down arrow will move the machine down.

Note. If the tow point cylinder will not move or the raise and lower are backward then take the following steps:

The default value of the controller for the valve current may need to be increased for the machine to move.

Make sure that there is not a cylinder shut off that is closed.

Double-check the Hydraulic setting of the controller to match the machine.

Note. If your machines raise and lower are backward then take the following step:

By swapping the connectors at the valve you will change the raise and lower.

With the above steps complete and you can raise and lower the machine you can now start to program the valve speeds of the machine.

Steps to setting Valve Speeds:

1. Enter the Technicians menu of the controller and go to the Min Up value. Refer to page two for this procedure.

The standard parameter menu can be called up from the working menu only.

Therefore:

First switch over to the operator menu by pressing the A/M key and the ENTER key at the same time.



Hold on the ENTER key for 3 seconds until „PA“ is indicated.



Hold on for 3 seconds



Within the next 3 seconds the key sequence:

- 1) – ENTER key
 - 2) – DOWN key
 - 3) – UP key
- has to be pressed.



Note.

After step 3 is complete you will see HYD in the Display. By depressing the blue button you will go to the Min Up symbol.

(\square - \square) **Min UP Current**

(\square - \square) **Min DOWN Current**

(\square - \square) **Max UP Current**

(\square - \square) **Max DOWN Current**

2. With the Min Up value in the display, lower this down to its lowest number. Then depress the blue button once and it will go to the Min Down value and lower this number as well. After this is complete depress the A/M button until you are at the working display.

3. Lower the machine so that the Drum is about 3" off the ground, even across and your end gate is flat on the ground.

Note.

In some cases your End Gate may not touch the ground with the machine 3" off the ground. By blocking the End Gate this will give you the offset that you need.

4. Connect a grade sensor and for this exercise we will pick the wire rope.

5. Zero your sensor by depressing the Blue button on the controller and the display should read 0.0

6. Put the controller in automatic by depressing the A/M button. At this time you should have 0.0 in the display and the Automatic light should be illuminated.

7. Depress the up arrow two times until the display reads 0.2. At this time you should have a flashing up arrow with the machine **Not Moving Up**.

8. While the controller is in automatic, enter the Technicians menu and go to the Min up value and raise the number slowly until the machine goes to grade.

b. At this time you should still have Min Up in the display and you can now depress the Blue button and go to the Min Down value.

9. By using the manual switch for the front leg, just bump the switch to make the machine go up and the Controller will flash a down arrow.

10. Increase the Min Down value slowly until the machine moves to grade and stops.

11. Jog the manual switch up and it should come to grade. Jog the manual switch down and the machine should come to grade. If it still flashes a little then just increase the value one or two until it goes to grade and repeat this step.

Adjusting the Max Up and Max Down.

For a good starting point for Max Current Speed add 10-15 to the Min current for example, if you have a Min Up value of 20 then you would set your Max UP to 30 - 35.

After confirming steps 3,4,5 and 6 proceed to the next step.

12. With the Manual switch drop the machine down about 1.5" to 2" and watch the speed of the machine.

d. If it is too slow then leave the controller in automatic and go to the Technicians Menu, refer to the Max Up value and add another 5 to 10. Stay in the Max Up and repeat step 12.

Note.

If it is too fast then drop your numbers another 5 to 10.

- e. Once you are getting close to the speed that you want drop down to steps of 5 until you like what you see and there is **No Over Shooting**.
- f. Your Machine should start moving as soon as the manual switch is released. The machine should Accelerate up, then start Decelerating to grade and stop at the **On Grade Symbol**.
- g. Once the up side is good, go to the Max Down by depressing the Blue button and proceed to 13.

13. With the Manual switch raise the machine Up about 1.5" to 2" and watch the speed of the machine.

- d. If it is too slow then leave the controller in automatic and go to the Technicians Menu, refer to the Max Down value and add another 5 to 10. Stay in the Max Down and repeat step 13.
- e. Once you are getting close to the speed that you want, drop down to steps of 5 until you like what you see and there is **No Over Shooting**.
- f. Your Machine should start moving as soon as the manual switch is released. The machine should Accelerate Down, then start Decelerating to grade and stop at the **On Grade Symbol**.
- g. Once the Down side is good, depress the A/M button until you return to the working display.

14. With the above steps complete you are ready to get the machine in the cut. A great help in knowing that you have tuned this machine correctly is watching the lights on the controller while the machine is cutting.

- d. You should see the **On Grade Symbol** most of the time **with a flashing up or down arrow**.
- h. If you see a lot of flashing in one direction or both then leave it in Automatic, go to the Technicians menu and adjust your Min up or Min down 1 – 2 and see if this helps.
- i. After your changes depress the A/M button and return to the working display keeping in mind that the Automatic light should still be illuminated.

16. Declaration of conformance

CE KONFORMITÄTSERKLÄRUNG

Entsprechend ISO/EC Guide 22 und EN 45014

Name des Herstellers: MOBA Mobile Automation

Anschrift des Herstellers: MOBA Mobile Automation
Vor den Eichen 4
D-65604 Elz

Der Hersteller erklärt, dass die Produkte:

Produktname: MOBA-matic System

Modell-Nr. der im System getesteten Geräte:

Digitaler Regler	04-25-10443 und 453
Digi Slope Sensor	04-21-21010
Sonic-Ski	04-21-10020
RotarySensor	04-21-40110
Seilzugsensor	04-21-30020
Laserempfänger LS-250	04-60-11010

den folgenden Produktspezifikationen entspricht:

Sicherheit: DIN VDE 411, Teil 1, 0001/10.73

EMV (EMC): EN 55011 - DIN VDE 0875 T11 (1992), Grenzwertklasse B
ENV 50140 - DIN VDE 847 T3 (1993) Kriterium A
ENV 50140 - DIN VDE 847 (1993), IEC 65A/77B (Sec) 145/110 Kriterium A
EN61000-4-2 (1995), IEC 1000-4-2 (1995), VDE0847 Teil 4-2 Kriterium B
ENV50141 (1993), E IEC 1000-4-6, E DIN VDE 0843 T6:12/93
EN61000-4-4:1995, IEC 1000-4-4:1995, VDE 0847 Teil 4-4 Kriterium B

Kriterien nach EN 50082 T/2

Zusätzliche Informationen:

Das Produkt entspricht den Anforderungen der EMV-Verordnung 89/336/EWG. Es wurde in einer typischen Konfiguration getestet. Die Inbetriebnahme der Komponenten ist solange untersagt, bis festgestellt wurde, dass die Maschine, in die dieses Produkt eingebaut werden soll, den Bestimmungen der EG-Richtlinie entspricht.

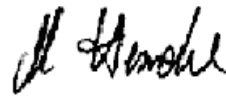

Elz, den 04 Juli 2002

Dipl.-Ing. Markus Wendel
Qualitäts-Management-Beauftragter