Operation & Maintenance Manual

MOBA
MECHANICAL GRADE & SLOPE
CONTROL SYSTEM

G 176 Plus - Grade Control

S 276 Plus - Slope Control

Parameter Settings

Manual Part No. 499992526011

(Form No. 24580)

G 176 plus Operating instructions -english-



The text and graphics of this manual have been elaborated with the greatest possible care. However, we may not be held liable for possible errors and failure effects.

Should you wish to make suggestions regarding the arrangement of this manual or point out possible errors, please contact your local dealer. We will gladly take up any of your ingenious ideas and suggestions.

Some company and label names are subject to label-, patent- or trade-mark protection.

All rights reserved. This document must not be duplicated or transferred for any purpose whatsoever without MOBA's written consent, irrespective of the way or the means which are used.

Order-no.: 10-02-00536

Date: 12.2005



MOBA

Mobile Automation AG

Kapellenstr. 15

D-65555 Limburg

Internet: www.moba.de

Index

1. General information	4
1.1 Introduction	4
1.2 Packaging and storage	5
1.3 Precautionary measures	6
2. Product description	9
3. System summary	10
4. Mounting of the G 176 plus	11
4.1 Attaching the connecting cable	12
4.2 Valve interruption function	13
4.3 Attaching the system components	14
4.4 Methods of sensing	15
5. Operating and working examples	16
5.1 Description of the G 176 plus	16
5.2 The control elements	16
5.3 LED display	17
5.4 Push button unit	18
5.5 Sensitivity settings	19
5.5.1 Sensitivity table	20
5.6 Working with the G 176 plus	21
5.6.1 String line sensing	21
5.6.2 Ground sensing	22
6. Module functions	23
7. Maintenance	24
7.1 General information	24
7.2 Periodic maintenance	24
7.3 Cleaning of device	24
8. Technical data	25
9. Declaration of conformance	26

1. General information

1.1 Introduction

This manual contains important information concerning the installation, initiation and operation of the G 176 plus, as well as advice for maintenance and trouble shooting. Furthermore, you will find a detailed description of all operating elements and their functions.

A description of all interfaces and their configuration is enclosed for the purpose of connection and trouble shooting.

Pictograms and symbols:

The following pictograms and symbols are used in this manual:



Residual risks and sources of danger in the event of improper handling which place the life and limb of operating personnel at risk are marked by a warning triangle with an exclamation mark. This also applies to potential damage to equipment.



Notes which need to be observed are indicated by a hand symbol.



Particularly important notes are printed in bold type.

- Lists are marked by a black dot.
- Operating steps to be performed by operating personnel are indicated by an arrow head.

Subject to change (without notice):

We have taken trouble to keep the information in these operating instructions correct and up to date. To maintain our technical leadership it may be necessary, without notice, to make changes to the product or its operation which, in certain circumstances, do not correspond to these instructions. In this case your MOBA supplier can supply up to date operating instructions. We accept no liability for disturbances, breakdowns or damages caused thereby.

1.2 Packaging and storage

In order to ensure adequate protection during transport, the products have been carefully packed.

On receipt the goods and the packaging should be checked for damage.



In case of damage the equipment must not be operated!

Damaged cables or connectors are also a risk to safety and, likewise, must not be used!

In this case, please contact your MOBA supplier.



If the equipment is not to be used directly after it is unpacked it must be protected from dampness and dirt.

1.3 Precautionary measures



Before mounting, servicing and operating the equipment please read the operating instructions carefully and completely. If questions arise, please contact your MOBA supplier.

Safety measures:

The safety measures recommended here correspond basically to the guidelines for installation and commissioning of electrical systems. They can be used for all applications in conjunction with MOBA equipment.

Mounting:

When mounting the equipment only original MOBA-cables may be used. The connectors may not be disconnected from the cables because they are protected against dampness; opening them will destroy the protection. Make sure that the securing screws of all the connectors are tightened. Further mounting information for the equipment and sensors can be taken from the enclosed data sheets or the installation instructions.

Wiring:

The wiring must be carried out correctly and corresponding information given in these instructions. All supply leads and connecting terminals must be sized for the corresponding current. Further, all connections must be made in accordance with valid VDE regulations or with valid national regulations.

Safety against disturbances:

This equipment has been designed for industrial use and has been tested correspondingly. Nevertheless, microprocessor technology puts certain demands on the installation. We would therefore like to point out the following things about an installation that, if not taken into account, can lead later to disturbances during operation:

- Make sure that the polarity of the connections is correct;
- Supply voltages may not exceed, or fall short of, the given ranges;
- Protect the equipment with a suitable supply fuse;
- Use cables suitable for the currents and voltages;
- Make the cabling paths as short as possible (avoid loops);
- Separate control cables from power cables as far as possible;
- Suppress contactor and relays coils;
- The requirement for a disturbance-free operation is a good electrical connection between the machine and the case/chassis of the separate components;
- Connect screened cables to earth at one end only (the equipment end);
- Do not supply other equipment directly from the supply terminals of this equipment;
- Do not use unused terminals as connection points for other equipment;
- Remove all system components resp. disconnect their power supply before welding;

Maximum Voltages:

Do not exceed the maximum allowed voltages. If not otherwise noted, the maximum voltage between any two isolated circuits, or between one circuit and earth is limited to the highest value of the corresponding input voltage or the corresponding supply voltage. The connecting terminals or plug must be equipped with a fuse.

Fuses:

The equipment is fitted with electronic fuses for protection against crossed connections, voltage spikes and short term over-voltages. The supply voltages given in the technical data may not be exceeded.

Configuration:

The equipment can be configured by the user. When reconfiguring, the user is obliged to do this only in accordance with the circumstances of the complete system.

Alarm device:

In complex systems, in which a malfunction could lead to danger to the operating personnel or to the system, it is wise to employ an independent alarm device to supervise the process. An independent device offers protection by announcing an alarm and switching off the system. In many cases the use of an alarm in the controller does not, because it is not independent of the control system, provide adequate protection.

Areas endangered by explosion:

The equipment is **not** for use in areas endangered by explosion.

Clearance of faults:

Before starting to clear faults make sure that every voltage supply to the equipment has been removed. Faulty equipment should be examined in an area suitably fitted out for test purposes. Every attempt to correct a fault in equipment that is still installed can be dangerous for personnel and for the system.

Ask for help:

For questions about the operation or about mounting please contact your MOBA supplier.

If the above precautionary measures are not observed, this can lead to a failure of the equipment, of the machine or even injury to personnel. Damage or injury, which is traceable to non-observance of the precautionary measures described above, is excluded from the manufacturer's guarantee.

2. Product description



The G 176 plus controller is used for the automatic levelling of a tool. The controller is designed for mobile application and particularly for the use in rough environment. Most of the time the unit is used for the levelling on asphalt pavers therefore an asphalt paver is used for explaining the main functions in this manual. The G 176 plus is also designed for milling machines, concrete pavers and other construction equipment.

The unit is mounted on the machine and follows a reference using a special sensing tool. A change in height between the machine and reference will cause a rotation of the sensing axis. The sensor determines the angle of rotation and the change in height is calculated. Proportional to this value the controller adjusts the valves to correct the height.



You can add a Slope sensor S 276 plus to the levelling system, if required.

3. System summary

Component	Description	Article-No.	Remark
	Grade controller G 176 plus	04-15-00300	
	G 176 plus System Grade controller with connecting cable-6m, sensing-arm, sensing-ski and sensing-tube	05-15-00300	
	Case - Grade/Slope for 2 Grade- and 1 Grade controller with equipment	04-06-00030	
	Connection box NPN/PNP to connect two NPN controller to an PNP machine	04-03-00081	with Vögele connector
	Sensing-arm incl. Counterweight	04-05-00070	
	Sensing-tube	04-05-00080	8" ~ 20 cm
		04-05-00090	16" ~ 40 cm
	Sensing-ski incl. Bolt and cotter pin	04-05-00100	
	Coil cable, Controller/machine	04-02-00012	10pol/7pol 90° 6 m

4. Mounting of the G 176 plus

The level controller G 176 plus can be mounted easily and rapidly with simple tools. For this purpose a fastening tube with a crank handle should be mounted as an extension of the control unit (on the asphalt paver at the tow arm close to the auger or at the milling machine on the protection housing of the drum)

1. Push ON push button to set STANDBY.
2. Loosen the locking screws of the fastening tube.
3. Insert the round mount boss that is on top of the controller's housing vertically into the fastening tube.
4. Turn the controller's housing so that the operator can see the lamps (front panel of the device against the direction of travel).
5. Lock the controller's mount boss to the fastening tube with the according locking screws.

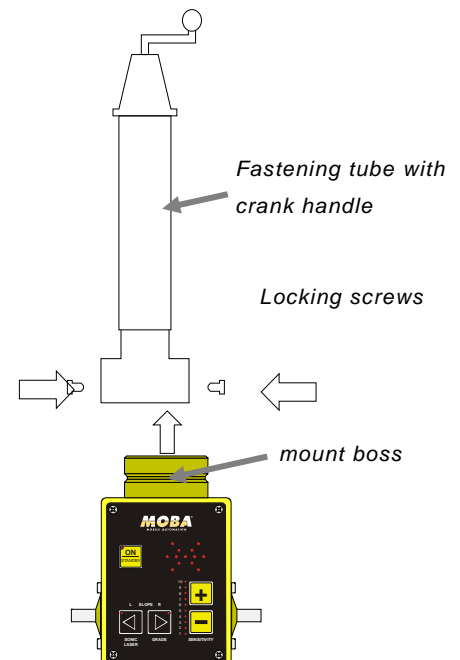

Mounting of the G 176 Plus

4.1 Attaching the connecting cable

Push the ON push button to set STANDBY. Connect the 7 pole socket of the connecting cable to the 7 pole plug of the controller. Connect the 10 pole socket of the connecting cable to the 10 pole device plug of the machine. About 70% of all pavers are equipped with a 10 pole machine connector. Therefore here we only handle this "standard connection". More connection types by request.

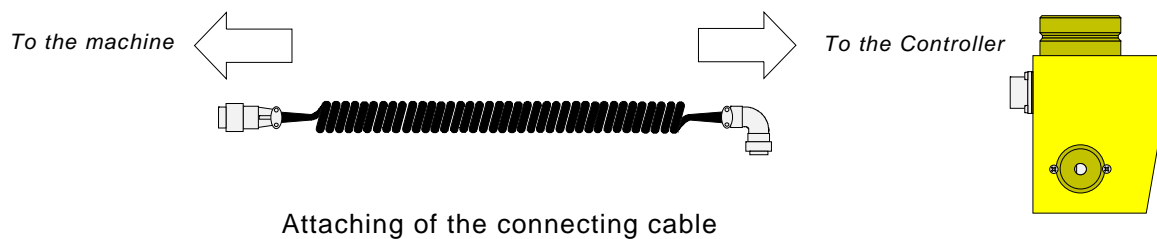

After supply voltage interruption all value and parameter settings are saved anymore.

4.2 Valve interruption function

In case of working safety the controller contains the special function “Input valve interruption”. Therefore pin F of the 7 pin connector (Pin J at 10 pin cable connector) provides a port which monitors the applied voltage. To use this function an extra switch has to be installed at a meaningful place on the machine, the control stand for example.

“Input valve interruption” is active if + VCC or – VCC is applied. Immediately no outputs are activated and the LED “ON push button” is flashing.

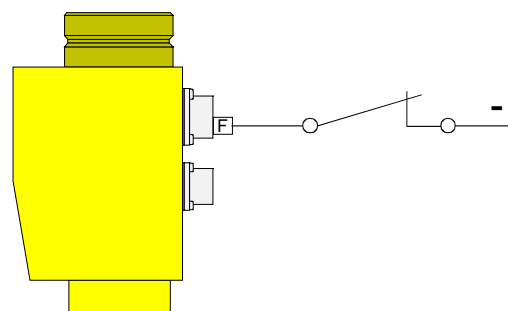
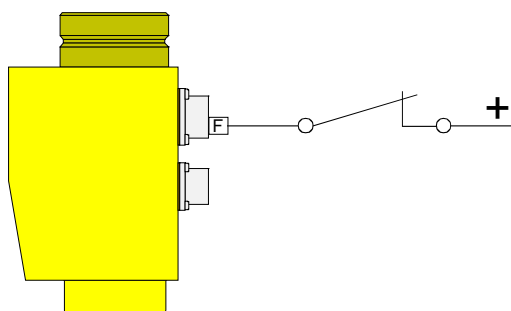

“Input valve interruption” is inactive if there is no specified electric potential applied that means the switch is open. The controller works in the usual way described in this manual.

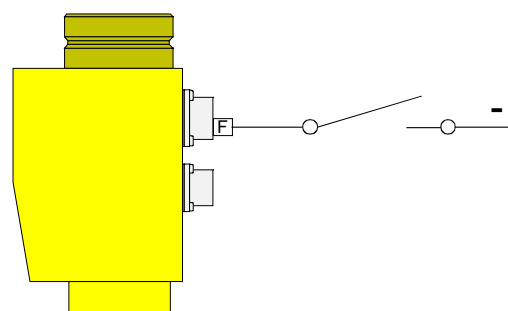
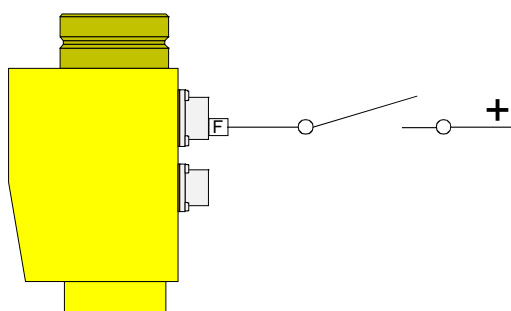

4.3 Attaching the system components

The system has two different sensors for sensing the reference. The sensing tube is used for sensing the string line. The sensing ski is used for sensing the ground.

Attaching the sensing tube to the sensor arm

1. Unscrew the nut at the end of the sensing tube.
2. Insert the end of the sensing tube into the fastening ring of the sensor arm.
3. Lock the sensing tube with the nut.

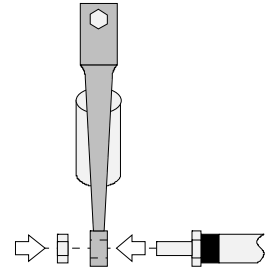

Attaching the sensing ski to the sensor arm

1. Remove the locking pin from the pin of the sensing ski;
Remove the pin.
2. Insert the fastening ring of the sensor arm into the fastener of the ski.
3. Push the pin through the fastener of the ski and the fastening ring of the sensor arm.
4. Lock the pin with the locking pin.

Attaching the sensor arm to the G 176 plus

1. Turn the flat part of the shaft towards the front of the controller.
1. Loosen the locking screw of the sensor arm.
2. Push the sensor arm on the shaft.
3. Lock the sensor arm with the locking screw.

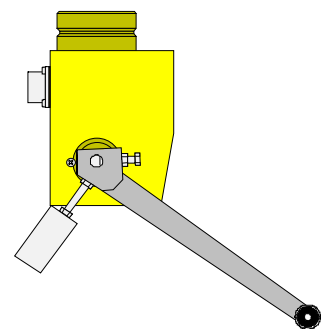
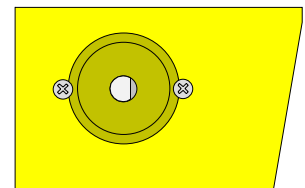

4.4 Methods of sensing

Sensing of a **string line** (with sensing tube)

Set the counterweight of the sensor arm in such a way that the sensor arm presses the sensing tube onto the reference. If the tension of the string line used a reference is too low, it is possible to guide the sensing tube beneath the string line with light pressure.

Sensing of a **surface** (with sensing ski)

Set the counterweight of the sensor arm in such way that the sensor arm presses the sensing ski onto the reference.

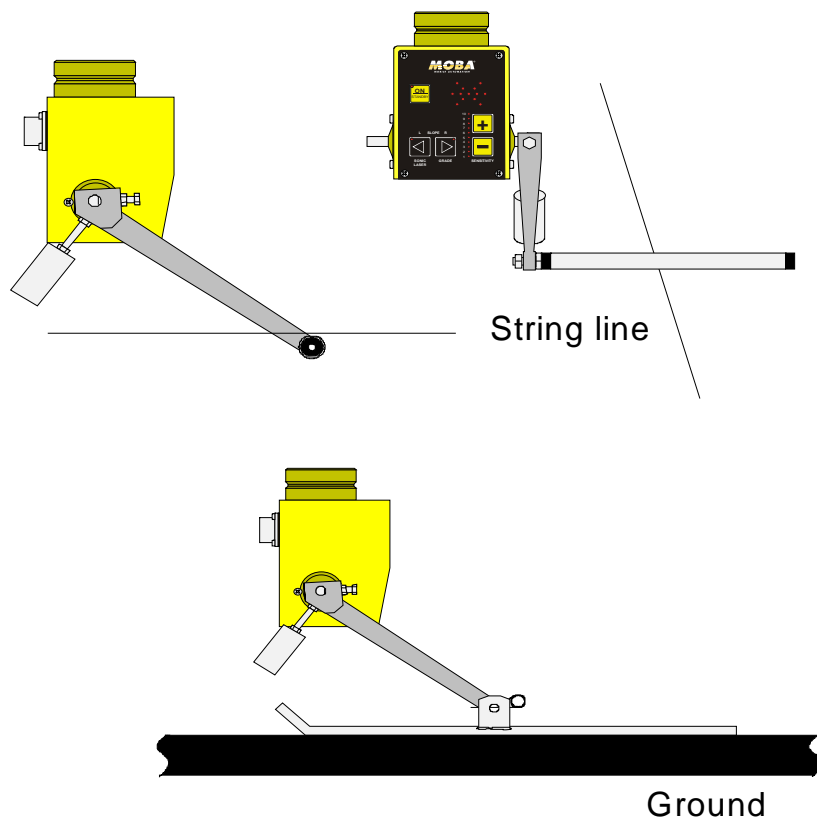

5. Operating and working examples

5.1 Description of the G 176 plus



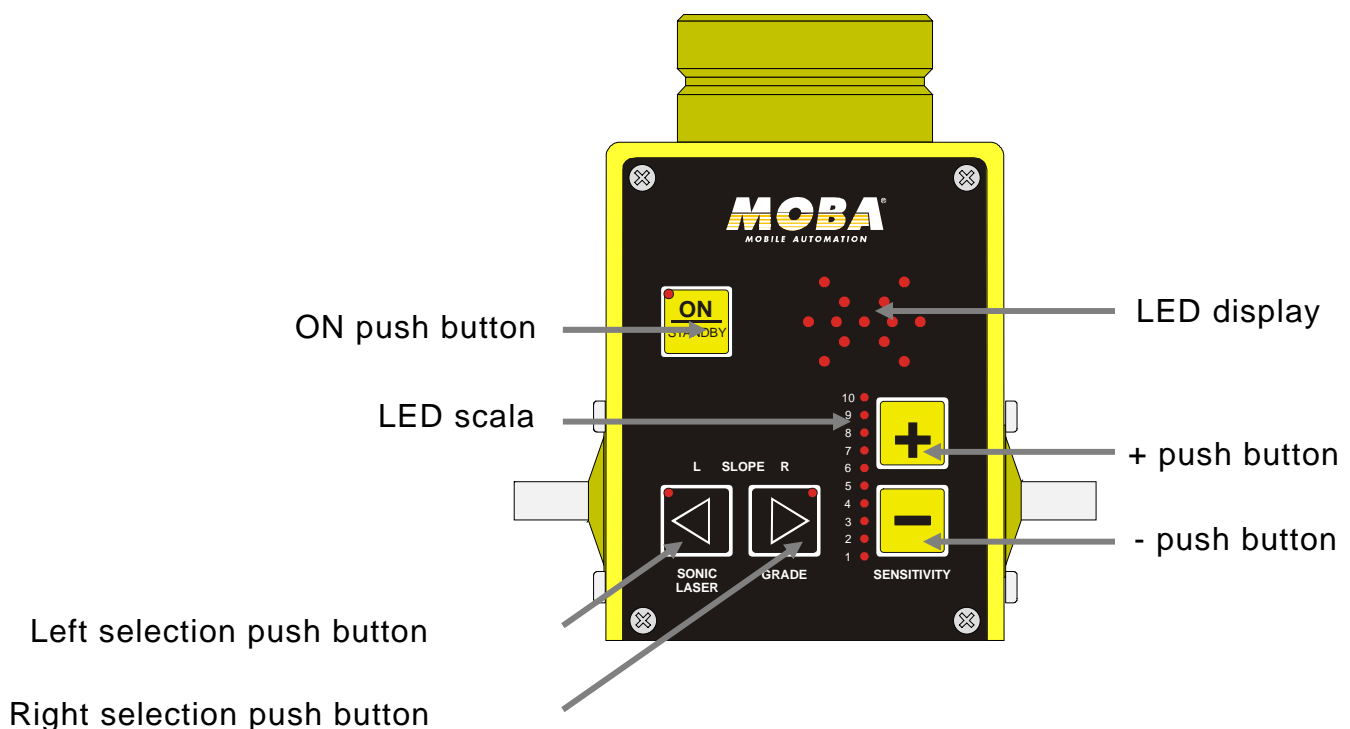

The controller has the capability to work with all kinds of construction machinery. Two LED displays and 5 push buttons are ensuring the ease of operation. The main working principal of the controller is the levelling process of a working tool (e.g. screed on a paver) in accordance with a defined reference. The controller is continuously sensing the reference. In case of a deviation between the reference and working tool the controller will start automatically steering the valves until the deviation is eliminated. Depending on the size of the deviation the controller is using variable output signals. Short output signals for small deviations, longer signals for bigger deviations. The result is a fast working speed with high accuracy.

5.2 The control elements

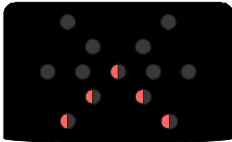

5.3 LED display

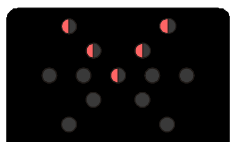
The LEDs are used to display the valve output actions.

LED- display	Deviation	Outputs (If activated)
 Arrow constanly on	Big control deviation	Output UP is constantly on
 Arrow flashes	Medium to small control deviation	Output UP is pulsing with variable pulse with
 Center on	No control deviation	No outout activated
 Arrow flashes	Medium to small control deviation	Output DOWN is pulsing with variable pulse with
 Arrow constanly on	Big control deviation	Output Down is constantly on

If control window function is activated:

Only in automatic mode.

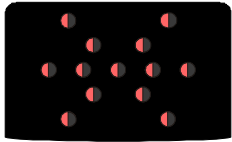
 All LEDs flashing	Out of control window	No output activated
--	-----------------------	---------------------

5.4 Push button unit

For the operation of the G 176 plus five push buttons are available. They facilitate simple operation.

ON push button



This button is used to change between ON (automatic) and STANDBY (manual)

LED ON = automatic mode

LED OFF = manual mode

LED flashing = external valve Interruption



+ push button

Increase sensitivity.



- push button

Decrease sensitivity.



left/ right selection control push button

At standard G 176 plus without function.

LED "Grade" is on.

5.5 Sensitivity settings

The LED scale shows the current chosen sensitivity.

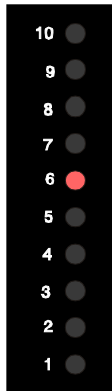

The adjustment for the sensitivity is reaching from 1 (low sensitivity) to 10 (high sensitivity). Sensitivity is a setting value which combines the governor settings of "death band" and "pulsing range".

In case of non smooth operation while the controller is in automatic mode you may have to change the setting value for the sensitivity. If the controller is working too slow you have to increase the sensitivity, if it's working too fast you have to decrease the value.

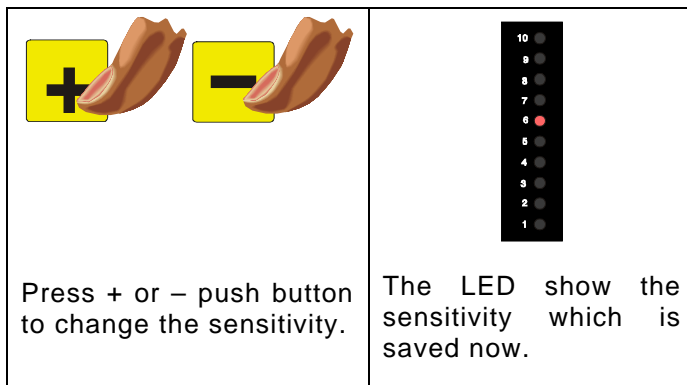

5.5.1 Sensitivity table





The following table provides relations between sensitivity and dead band and pulse range.

Sensitivity	Deadband	Pulse range
01	+/- 4,00 mm	18,0 mm
02	+/- 3,40 mm	16,0 mm
03	+/- 3,00 mm	14,0 mm
04	+/- 2,40 mm	12,0 mm
05	+/- 2,00 mm	10,0 mm
06	+/- 1,40 mm	8,0 mm
07	+/- 1,00 mm	6,0 mm
08	+/- 0,8 mm	5,0 mm
09	+/- 0,6 mm	4,0 mm
10	+/- 0,4 mm	3,0 mm



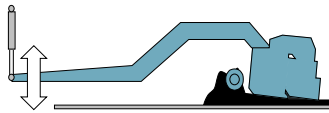
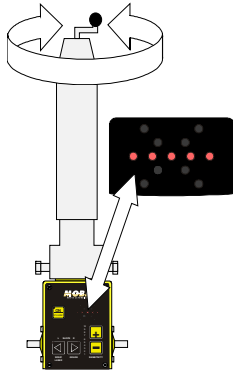
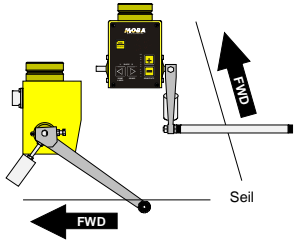

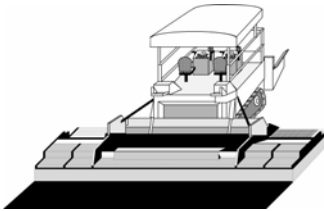
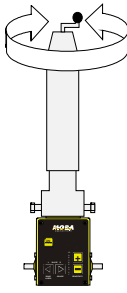
The denoted values in this table can deviate from device to device marginally.

5.6 Working with the G 176 plus

5.6.1 String line sensing

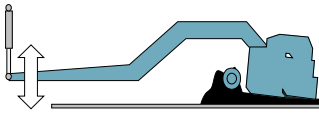
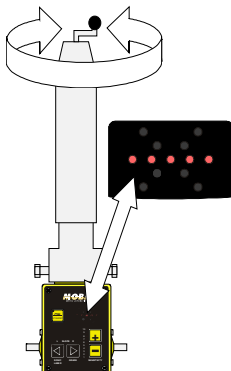
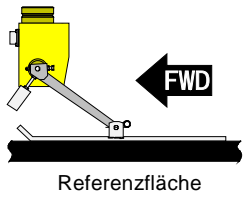

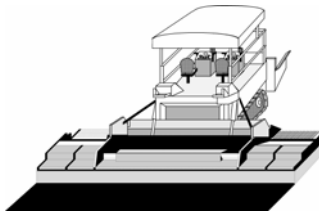
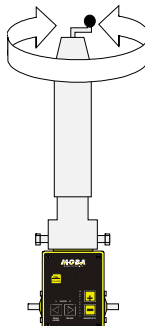
<p>1</p>  <p>Press the "ON push button" to switch over to manual mode. The function LED is off.</p>	<p>2</p>  <p>For zero setting, bring the tool into working position.</p>	<p>3</p>  <p>After the height of the controller with the adjustment leveller until the working set point is reached. The LED display confirms the zero setting with illuminated LEDs centred in the LED cross.</p>	<p>4</p>  <p>The sensing tube must exert a slight pressure onto the string line. The pressure can be adjusted with the counterweight.</p>
<p>5</p>  <p>Press the "ON push button" to switch over to automatic mode. The function LED is on. The valve outputs are active.</p>	<p>6</p>  <p>The controller keeps the tool at the adjusted value.</p>	<p>7</p>  <p>Use the adjustment leveller for altering the set point in automatic mode. ATTENTION! Each adjustment changes the weight force of the sensing tube.</p>	<p>8</p>  <p>You can switch back to manual mode anytime with the "ON push button". The automatic control of the valves will then be switched off. The function LED is off.</p>

5.6.2 Ground sensing

<p>1</p>  <p>Press the "ON push button" to switch over to manual mode. The function LED is off.</p>	<p>2</p>  <p>For zero setting, bring the tool into working position.</p>	<p>3</p>  <p>After the height of the controller with the adjustment leveller until the working set point is reached. The LED display confirms the zero setting with illuminated LEDs centred in the LED cross.</p>	<p>4</p>  <p>Referenzfläche</p> <p>The sensing ski has to exert a slight pressure onto the ground. The pressure can be adjusted with the counterweight.</p>
<p>5</p>  <p>Press the "ON push button" to switch over to automatic mode. The function LED is on. The valve outputs are active.</p>	<p>6</p>  <p>The controller keeps the tool at the adjusted value.</p>	<p>7</p>  <p>Use the adjustment leveller for altering the set point in automatic mode.</p> <p>ATTENTION! Each adjustment changes the weight force of the sensing ski.</p>	<p>8</p>  <p>You can switch back to manual mode anytime with the "ON push button". The automatic control of the valves will then be switched off. The function LED is off.</p>

6. Module functions

To choose the "Grade" or the "Slope" mode after changing a module, proceed the following description.

<p>1</p> <p>5 sec.</p>  <p>Change to "Grade" mode. Hold right selection push button 5 sec. until the LED is on.</p>	<p>2</p> <p>5 sec.</p>  <p>Change to "Slope" mode. Hold left selection push button 5 sec. until the LED is on.</p>
--	--

7. Maintenance

7.1 General information

The controller is designed for high working safety so that the maintenance needs a minimum of procedures only. The electronic components are mounted in a solid case in order to avoid any mechanical damage.

7.2 Periodic maintenance

The power supply cables should also be checked regularly in order to detect any damage and dirt.

Note:

Keep the thread of the plug-connections and of the cable connectors free of any dirt, grease, asphalt or concrete in order to avoid a bad contact. Remove any asphalt or concrete sticking to the sensor arm by means of an appropriate agent and oil the bearing afterwards.

7.3 Cleaning of device

Switch off the digital controller

- apply a normal washing-up detergent to a soft, lintfree piece of cloth
- clean appliance surfaces without pressure
- remove the detergent from the appliances with a clean piece of cloth

8. Technical data

Abmessungen (Dimensions):

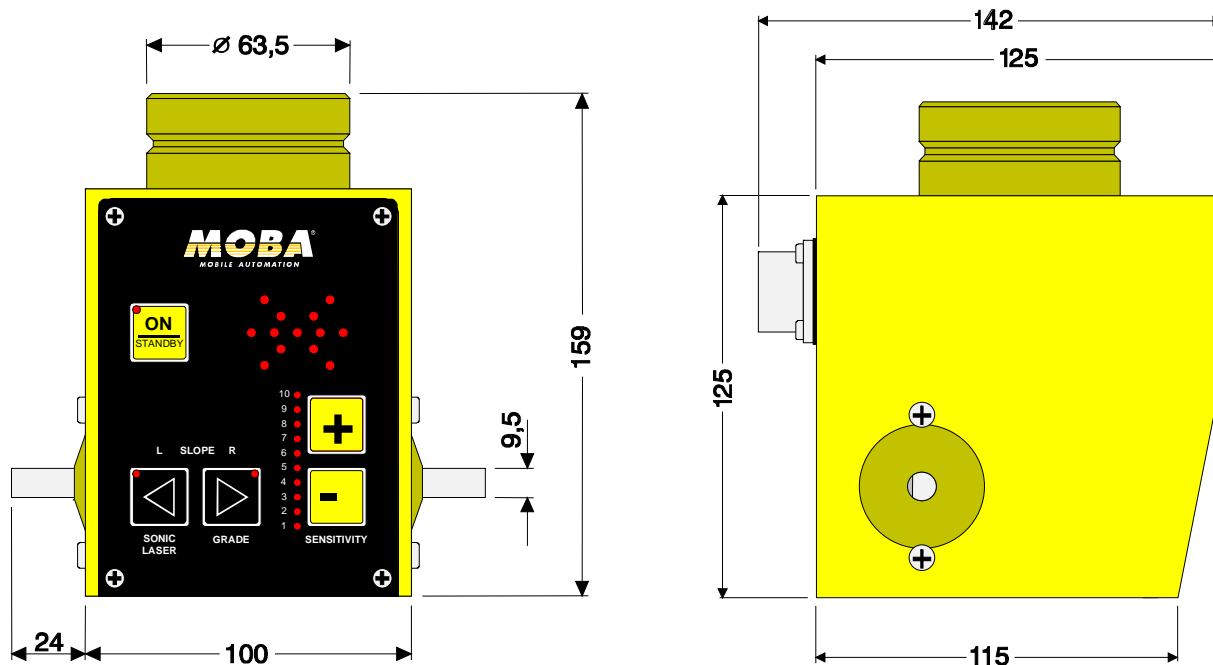

Technische Daten (Technical data):

Betriebsspannung (voltage range):
11 ... 30 V (DC)

Stromaufnahme (current consumption):
< 60 mA ohne Ventile (without valves)

Erfassungsbereich (measuring range):
+/- 70 mm; gemessen am Tastarm (measured at sensing arm)

Erreichbare Genauigkeit (obtainable accuracy):
+/- 0,5 mm; am Tastarm (at sensing arm)

Ausgänge, wählbar (outputs, selectable):
ON/OFF; NPN o. PNP, $I_{max} = 3$ Amp.
Freq. = 3 Hz., MinPuls = 10ms ... 190ms,
Servo, $I_{max} = 3$ Amp.

Arbeitstemperaturbereich (ambient temperature range):
-20 ... +80 °C

Lagertemperaturbereich (storage temperature range):
-25 ... +80 °C

Schutzart (enclosure protection):
IP 54

Gewicht (weight):
ca. 1,9 kg

Pinbelegung (Pin connection):

7pol. Gerätestecker; Schraubverbindung
(7pin connector; screwed connection)

A = + Betriebsspannung (supply voltage)
B = Ausgang "Senken" (output "lower")
C = - Betriebsspannung (supply voltage)
D = Ausgang "Heben" (output "raise")
E = n.c.
F = Eingang „extern Hand“ (input „valve interruption“)
G = n.c.

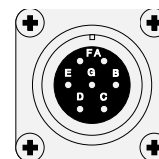

Bemerkung (Remark):

Zubehör:
Tastarm (sensing arm): 04-05-00070
Tastrohr (sensing tube): 04-05-00080
Tastski (sensing ski): 04-05-00100

9. Declaration of conformance

S 276 plus Operating instructions -english-



The text and graphics of this manual have been elaborated with the greatest possible care. However, we may not be held liable for possible errors and failure effects.

Should you wish to make suggestions regarding the arrangement of this manual or point out possible errors, please contact your local dealer. We will gladly take up any of your ingenious ideas and suggestions.

Some company and label names are subject to label-, patent- or trade-mark protection.

All rights reserved. This document must not be duplicated or transferred for any purpose whatsoever without MOBA's written consent, irrespective of the way or the means which are used.

Order-no.: 10-02-00581
Date: 12.2005



MOBA
Mobile Automation AG
Kapellenstr. 15
D-65555 Limburg
Internet: www.moba.de

Index

1. General information	4
1.1 Introduction	4
1.2 Packaging and storage	5
1.3 Precautionary measures	6
2. Product description	9
3. System summary	10
4. Mounting of the S 276 plus	11
4.1 Attaching the connecting cable	12
4.2 Valve interruption function	13
5. Operating and working examples	14
5.1 Description of the S 276 plus	14
5.2 The control elements of the S 276 plus	14
5.2.1 LED display	15
5.2.2 Push button unit	16
5.2.3 LED scale	17
5.2.4 Sensitivity table	18
5.3 The Control Elements of the Handset	19
5.3.1 LC-Display	20
5.3.2 Push buttons	21
5.4 Working with the S 276 plus	22
5.4.1 Sensitivity settings	22
5.4.2 Setting up the set point	22
5.4.3 Working with the S 276 plus	24
6. Module functions	25
7. Maintenance	26
7.1 General information	26
7.2 Periodic maintenance	26
7.3 How to clean the appliance	26
7.4 Trouble shooting	27
8. Technical data	28
9. Declaration of conformance	29

1. General information

1.1 Introduction

This manual contains important information concerning the installation, initiation and operation of the G 176 plus, as well as advice for maintenance and trouble shooting. Furthermore, you will find a detailed description of all operating elements and their functions.

A description of all interfaces and their configuration is enclosed for the purpose of connection and trouble shooting.

Pictograms and symbols:

The following pictograms and symbols are used in this manual:



Residual risks and sources of danger in the event of improper handling which place the life and limb of operating personnel at risk are marked by a warning triangle with an exclamation mark. This also applies to potential damage to equipment.



Notes which need to be observed are indicated by a hand symbol.



Particularly important notes are printed in bold type.

- Lists are marked by a black dot.
- Operating steps to be performed by operating personnel are indicated by an arrow head.

Subject to change (without notice):

We have taken trouble to keep the information in these operating instructions correct and up to date. To maintain our technical leadership it may be necessary, without notice, to make changes to the product or its operation which, in certain circumstances, do not correspond to these instructions. In this case your MOBA supplier can supply up to date operating instructions. We accept no liability for disturbances, breakdowns or damages caused thereby.

1.2 Packaging and storage

In order to ensure adequate protection during transport, the products have been carefully packed.

On receipt the goods and the packaging should be checked for damage.



In case of damage the equipment must not be operated!

Damaged cables or connectors are also a risk to safety and, likewise, must not be used!

In this case, please contact your MOBA supplier.



If the equipment is not to be used directly after it is unpacked it must be protected from dampness and dirt.

1.3 Precautionary measures



Before mounting, servicing and operating the equipment please read the operating instructions carefully and completely. If questions arise, please contact your MOBA supplier.

Safety measures:

The safety measures recommended here correspond basically to the guidelines for installation und commissioning of electrical systems. They can be used for all applications in conjunction with MOBA equipment.

Mounting:

When mounting the equipment only original MOBA-cables may be used. The connectors may not be disconnected from the cables because they are protected against dampness; opening them will destroy the protection. Make sure that the securing screws of all the connectors are tightened. Further mounting information for the equipment and sensors can be taken from the enclosed data sheets or the installation instructions.

Wiring:

The wiring must be carried out correctly and corresponding information given in these instructions. All supply leads and connecting terminals must be sized for the corresponding current. Further, all connections must be made in accordance with valid VDE regulations or with valid national regulations.

Safety against disturbances:

This equipment has been designed for industrial use and has been tested correspondingly. Nevertheless, microprocessor technology puts certain demands on the installation. We would therefore like to point out the following things about an installation that, if not taken into account, can lead later to disturbances during operation:

- Make sure that the polarity of the connections is correct;
- Supply voltages may not exceed, or fall short of, the given ranges;
- Protect the equipment with a suitable supply fuse;
- Use cables suitable for the currents and voltages;
- Make the cabling paths as short as possible (avoid loops);
- Separate control cables from power cables as far as possible;
- Suppress contactor and relays coils;
- The requirement for a disturbance-free operation is a good electrical connection between the machine and the case/chassis of the separate components;
- Connect screened cables to earth at one end only (the equipment end);
- Do not supply other equipment directly from the supply terminals of this equipment;
- Do not use unused terminals as connection points for other equipment;
- Remove all system components resp. disconnect their power supply before welding;

Maximum Voltages:

Do not exceed the maximum allowed voltages. If not otherwise noted the maximum voltage between any two isolated circuits, or between one circuit and earth, is limited to the highest value of the corresponding input voltage or the corresponding supply voltage. The connecting terminals or plug must be equipped with a fuse.

Fuses:

The equipment is fitted with electronic fuses for protection against crossed connections, voltage spikes and short term over-voltages. The supply voltages given in the technical data may not be exceeded.

Configuration:

The equipment can be configured by the user. When reconfiguring, the user is obliged to do this only in accordance with the circumstances of the complete system.

Alarm device:

In complex systems, in which a malfunction could lead to danger to the operating personnel or to the system, it is wise to employ an independent alarm device to supervise the process. An independent device offers protection by announcing an alarm and switching off the system. In many cases the use of an alarm in the controller does not, because it is not independent of the control system, provide adequate protection.

Areas endangered by explosion:

The equipment is **not** for use in areas endangered by explosion.

Clearance of faults:

Before starting to clear faults make sure that every voltage supply to the equipment has been removed. Faulty equipment should be examined in an area suitably fitted out for test purposes. Every attempt to correct a fault in equipment that is still installed can be dangerous for personnel and for the system.

Ask for help:

For questions about the operation or about mounting please contact your MOBA supplier.

If the above precautionary measures are not observed, this can lead to a failure of the equipment, of the machine or even injury to personnel. Damage or injury, which is traceable to non-observance of the precautionary measures described above, is excluded from the manufacturer's guarantee.

2. Product description



The S 276 plus controller is used for the automatic levelling of a tool. The controller is designed for mobile application and particularly for the use in rough environment.

Most of the time the unit is used for the levelling on asphalt pavers therefore an asphalt paver is used for explaining the main functions in this manual. The S 276 plus is also designed for milling machines, concrete pavers and other construction equipment.

The cross-slope controller has to be mounted at a part of the machine that carries out all slope changes in the same way as the tool does. After the set point is set the S 276 plus detects any cross-slope changes and determines the offset. The Controller steers the connected valves proportionally until the difference is corrected.



You can add a Grade sensor G 176 plus to the levelling system, if required.

3. System summary

Component	Description	Article-No.	Remark
	Slope controller S 276 plus	04-15-10300	
	S 276 plus system Slope controller with connecting cable-6m	05-15-10300	
	S 276 plus Basic unit	04-15-10250	
	Digital Handset for S 276	04-15-11010	
	Case - Grade/Slope for 2 Grade- and 1Grade controller with equipment	04-06-00030	
	Connection box NPN/PNP to connect two NPN controller to an PNP machine	04-03-00081	with Vögele connector
	Coil cable Controller/machine	04-02-00012	10pol/7pol 90° 6 m

4. Mounting of the S 276 plus

The cross-slope Controller has to be mounted at a part of the machine that carries out all slope changes in the same way as the tool does. In case of the paver, we recommend the cross linkage between the tow arms respectively the screed.

The connectors must be freely accessible, so that the interconnecting cable can be easily plugged in. For mounting purposes, four fixing holes are in the mounting plate of the controller. To decrease the loading stress, shock absorbers should be installed between the fixing plate and the chassis. The shock absorbers should be hard enough to avoid natural oscillation.

For best results check with a digital, highly precise water level during mounting. Please observe the direction of mounting. Mounting plates of S 276 plus and S 276 M are identical.

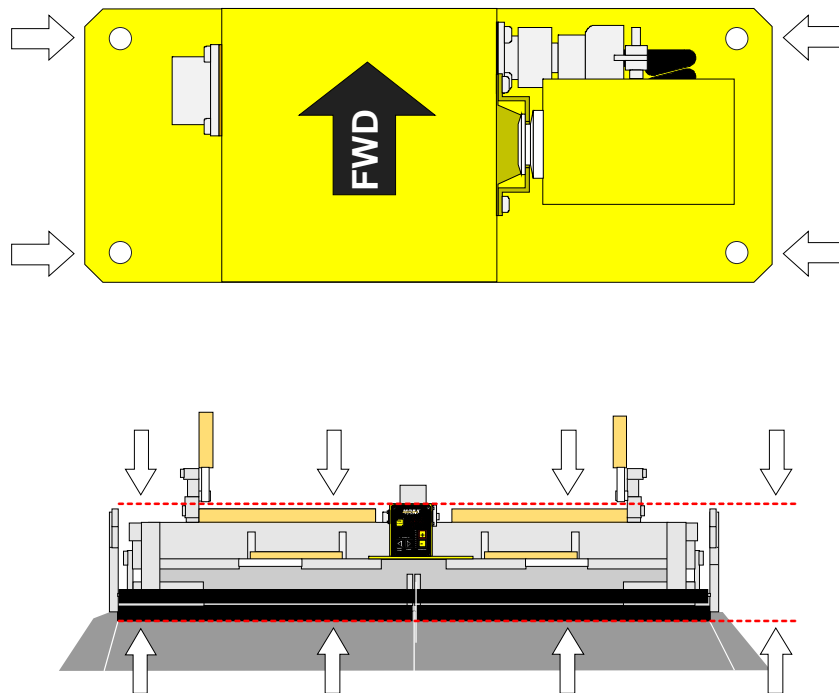

4.1 Attaching the connecting cable

Push the "ON push button" to set STANDBY. Connect the 7 pole socket of the connecting cable to the 7 pole plug of the controller. Connect the 10 pole socket of the connecting cable to the 10 pole device plug of the machine on the side that shall be controlled. About 70% of all pavers are equipped with a 10 pole machine connector. Therefore only this "standard connection" is described. Further connection types upon request.

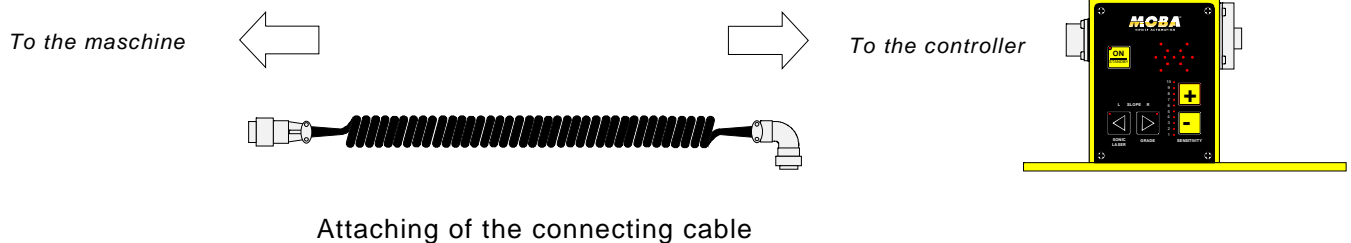

After supply voltage interruption all value and parameter settings are saved anymore.

4.2 Valve interruption function

In case of working safety the controller contains the special function “Input valve interruption”. Therefore pin F of the 7 pin connector (Pin J at 10 pin cable connector) provides a port which monitors the applied voltage. To use this function an extra switch has to be installed at a meaningful place on the machine, the control stand for example.

“Input valve interruption” is active if + VCC or – VCC is applied. Immediately no outputs are activated and the LED “ON push button” is flashing.

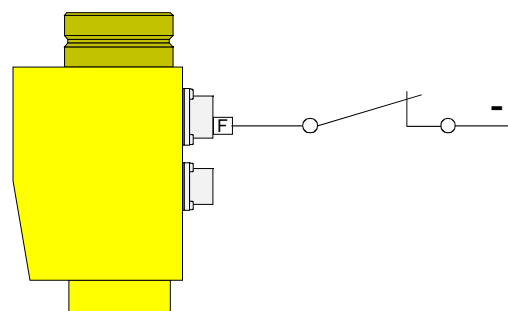
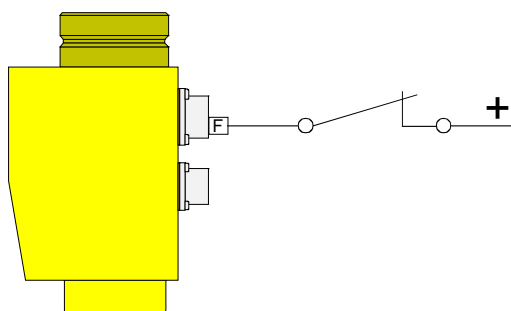

“Input valve interruption” is inactive if there is no specified electric potential applied that means the switch is open. The controller works in the usual way described in this manual.

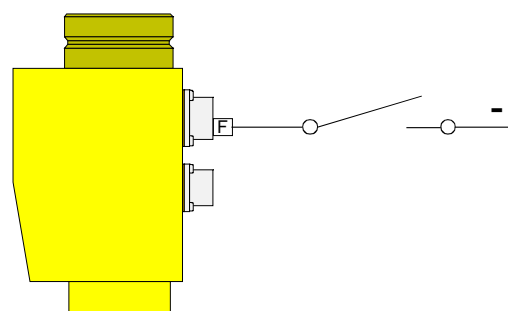
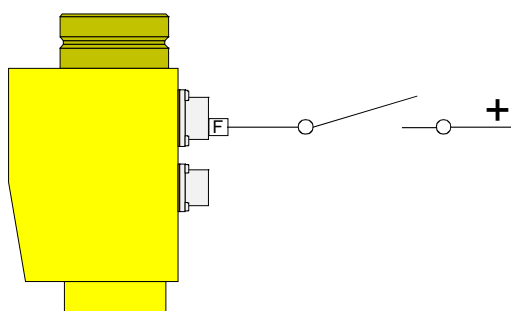

5. Operating and working examples

5.1 Description of the S 276 plus

The controller has the capability to work with all kind of construction machinery.

Two LED displays and five push buttons are ensuring the ease of operation.

The handset with its 3½- digit liquid crystal display and four push buttons ease working with the S 276 plus.

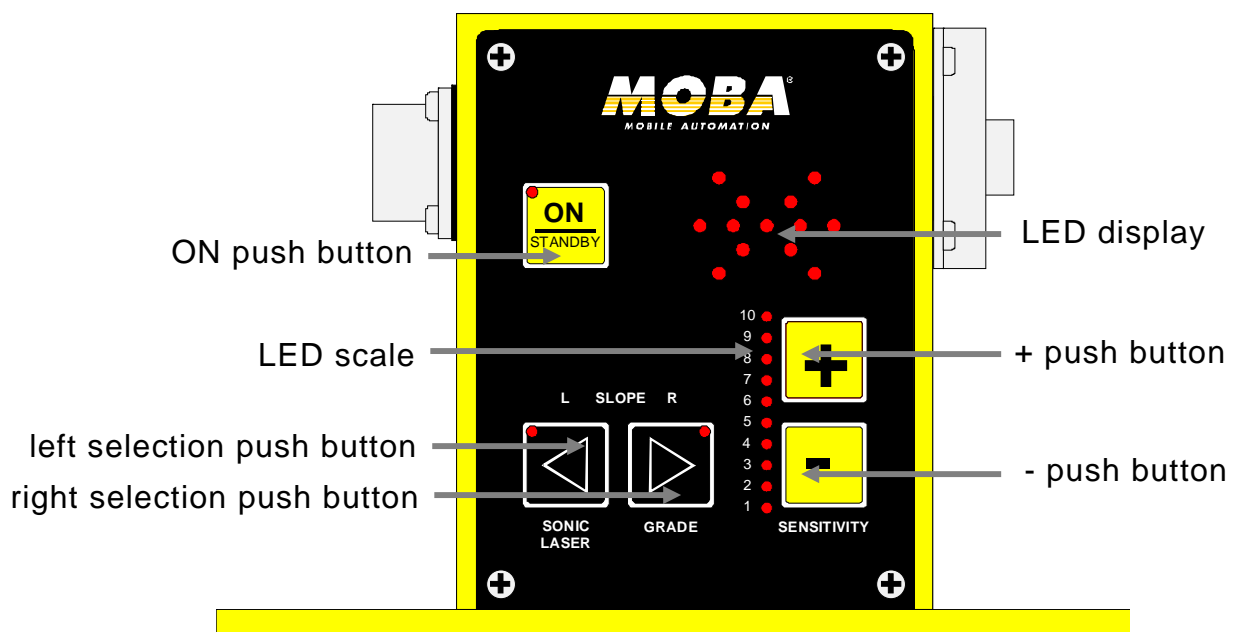

The main working principal of the controller is the levelling process of a working tool (e.g. screed on a paver) in accordance with a defined reference. In case of a deviation between the reference and working tool the controller will start automatically steering the valves until the deviation is eliminated. Depending on the size of the deviation the controller is using variable output signals. Short output signals for small deviations, longer signals for bigger deviations. The result is a fast working speed with high accuracy.

5.2 The control elements of the S 276 plus

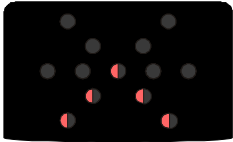

5.2.1 LED display

The LEDs are used to display the valve output actions.

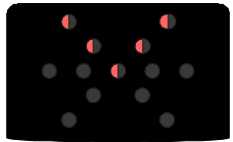
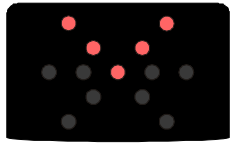
LED- display	Deviation	Outputs
 Arrow constanly on	Big control deviation	Output UP is constantly on
 Arrow flashes	Medium to small control deviation	Output UP is pulsing with variable pulse with
 Center on	No control deviation	No outout activated
 Arrow flashes	Medium to small control deviation	Output DOWN is pulsing with variable pulse with
 Arrow constanly on	Big control deviation	Output Down is constantly on

5.2.2 Push button unit

For the operation of the S 276 plus five push buttons are available. They facilitate simple operation.

ON push button



This button is used to change between ON (automatic) and STANDBY (manual)

LED ON = automatic mode

LED OFF = manual mode

LED flashing = external valve Interruption



+ push button

Increase sensitivity.



- push button

Decrease sensitivity.

left/ right selection

Left push button = Control of left side.

(Connected to the left side of the machine).



Right push button = Control of the right side.

(Connected to the right side of the machine).

LED "Grade" is on.

5.2.3 LED scale

The LED scale shows the currently chosen sensitivity.

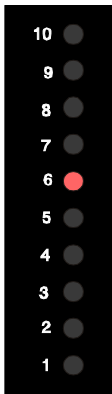

The adjustment for the sensitivity is reaching from 1 (low sensitivity) to 10 (high sensitivity). Sensitivity is a setting value which combines the control parameters of "death band" and "pulse range".

In case of non smooth operation while the controller is in automatic mode you may have to change the setting value for the sensitivity. If the controller is working too slow you have to increase the sensitivity, if it's working too fast you have to decrease the value.

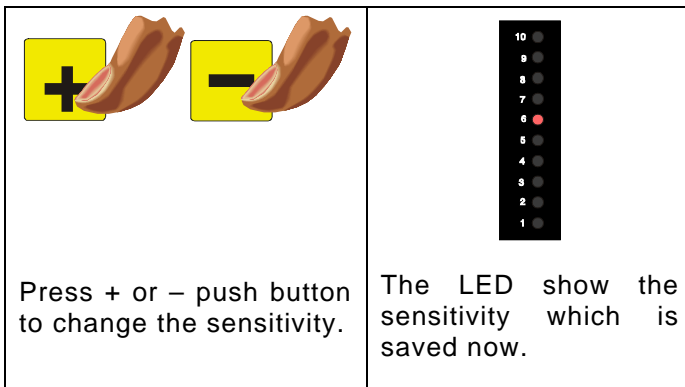

5.2.4 Sensitivity table

The following table provides relations between sensitivity and dead band and pulse range.

Sensitivity	Deadband (%)	Pulserange (%)
01	0.40	+/- 1.60
02	0.30	+/- 1.40
03	0.20	+/- 1.20
04	0.14	+/- 1.00
05	0.10	+/- 0.80
06	0.06	+/- 0.60
07	0.04	+/- 0.50
08	0.02	+/- 0.40
09	0.02	+/- 0.30
10	0.00	+/- 0.20

The denoted values in this table can deviate from device to device marginally.

5.3 The Control Elements of the Handset

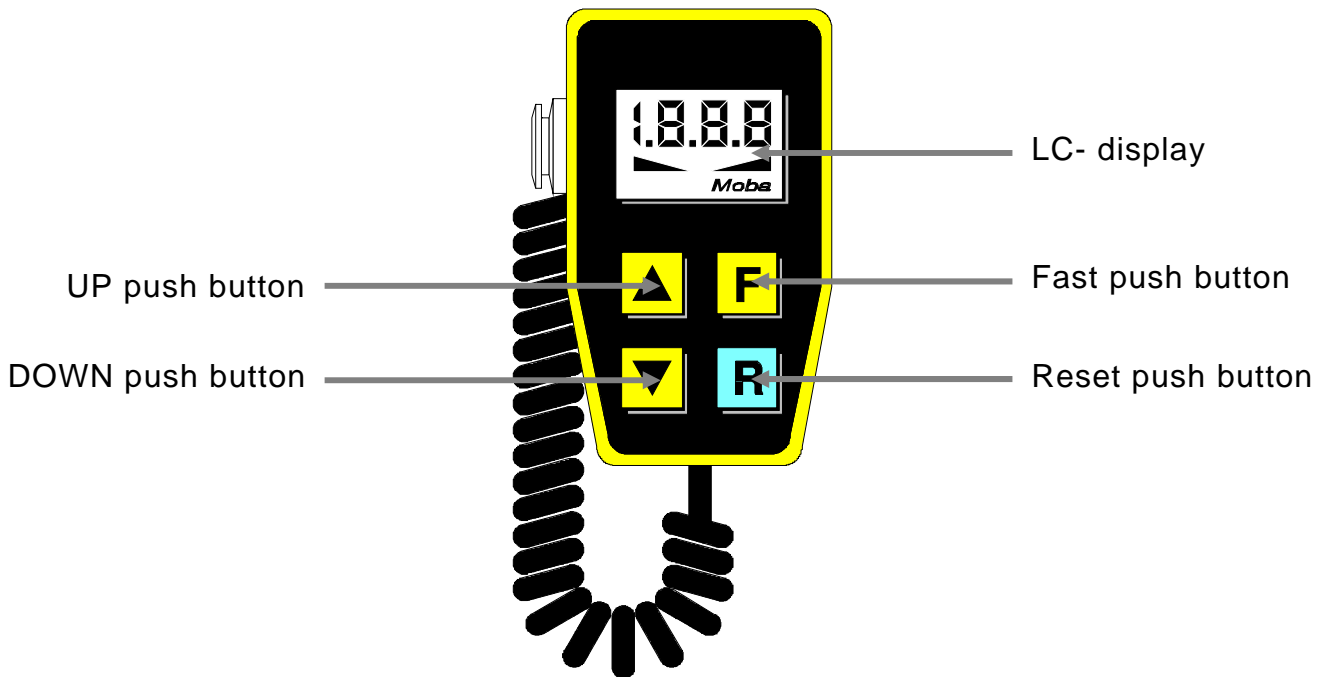

5.3.1 LC-Display

The 3½- digit liquid crystal display is, because of its integrated illumination well readable. The display symbols have the following significance:



Slope to the right (bar dropping down to the right).



Slope to the left (bar dropping down to the left).



Zero point (Slope to the right/left constantly on).



UP/Down arrow constantly on during zero setting.

5.3.2 Push buttons

For the operation of the Handset four push buttons are available. They ensure simple operation



UP/DOWN push button

Setting of cross-slope or displayed values.



Fast push button

Increase the speed of the adjustment procedure in combination with the UP/DOWN button



Reset push button

Adjust displayed values without changing the set point in addition with "UP/DOWN push button".



5.4 Working with the S 276 plus

5.4.1 Sensitivity settings

Increase the sensitivity while the machine is running and control in Automatic Mode. When Hydraulics starts swinging, decrease sensitivity until the swinging stops. When being used for the first time, readjustment might be necessary, as vibrating, temperatures etc. have an impact on the control loop. After this readjustment, usually no further setting procedure has to be performed.

5.4.2 Setting up the set point



The first time setting up the set point has to be done during the implementation of the S 276 plus. With this procedure, the indicated value of the digital controller will be adjusted to the actual cross-slope of the tool to be controlled.

In the following example, we will describe how to set the numerical value of an adjusted slope set point to the measured value of the working result while working in automatic mode.

Procedure: Adjustment of set point while working in automatic mode

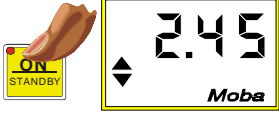
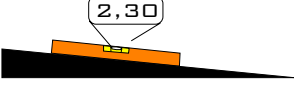
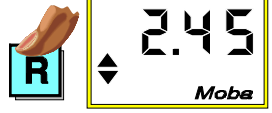
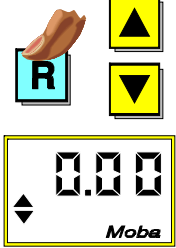
<p>1</p>  <p>The system is in automatic mode (function lamp "ON" is on). In this example the control works with a set point of 2,45 %.</p>	<p>2</p>  <p>Measure the working result with a digital, highly precise level. Let's assume that the actually measured value is only 2,30%.</p>	<p>3</p>  <p>Hold "Reset push button" till "UP/DOWN arrows" are on constantly.</p>	<p>4</p>  <p>Hold "Reset push button" and press "UP/DOWN push buttons" to set the set point to 2.30. After that release "Reset push button".</p>
---	---	--	---

If necessary repeat step 2 to 4 until the adjusted set point and the produced cross-slope are identical.







For best working results the measured value has to be checked and necessary readjusted in periodical intervals.

Generally the procedure for setting up the measured value has to be repeated if the S 276 plus was exchanged, the mounting position changed or any mechanical changes were made at the tool or its fastening (e.g. mechanical adjustment of the screed's angle of attack at the paver).

5.4.3 Working with the S 276 plus

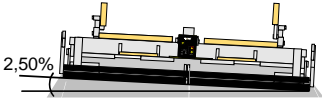
It is assumed that the controller was mounted, the cables were connected and the setting of the measured value was done.

Procedure: Controlling with the S 276 plus controller

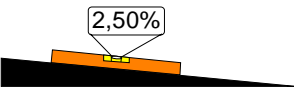
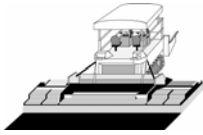
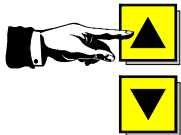
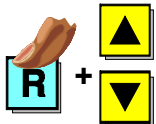
<p>1</p>  <p>Press the "ON push button" to switch over to manual mode. The function LED is off.</p>	<p>2</p>  <p>Proceed the tool (start position manual) into working position.</p>  (here: 2,50 %, right Slope)	<p>3</p>  <p>Use Handset to adjust the set point (2,50 %). In ideal case the LEDs centred in the LED cross.</p>	<p>4</p>  <p>Press the "ON push button" to switch over to automatic mode. The function LED "ON" is on. The controller keeps the tool at the adjusted value.</p>
<p>6</p>  <p>Measure the working result with a digital, high precise level.</p>	<p>6a</p>  <p>After desired value is reached, the usual work can be resumed.</p>	<p>6b</p>  <p>If desired value is not reached it can be changed stepwise with UP/DOWN buttons.</p>	<p>7</p>  <p>To adjust the value displayed on the handset to the cross slope, use the R-button and the UP/DOWN buttons.</p>

8



At any time you can switch back to the STANDBY mode. The automatic drive of the valves will then be switched off.

Sensitivity setting

If the control in automatic mode is too sluggish or unstable the sensitivity setting should be changed accordingly. The procedure is described in section 6.4.1 of these operating instructions.

6. Module functions

To choose the "Grade" or the "Slope" mode after changing a module, proceed the following description.

<p>1</p> <p style="text-align: center;">5 sec.</p> <p>Change to "Grade" mode. Hold right selection push button 5 sec. until the LED is on.</p>	<p>2</p> <p style="text-align: center;">5 sec.</p> <p>Change to "Slope" mode. Hold left selection push button 5 sec. until the LED is on.</p>
---	--

7. Maintenance

7.1 General information

The level controller has been designed for high working safety so that the maintenance needs a minimum of procedures only. The electronic components are mounted in a solid case in order to avoid any mechanical damage.

7.2 Periodic maintenance

The power supply cables should also be checked regularly in order to detect any damage and dirt.

Note:

Keep the thread of the plug-connections and of the cable connectors free of any dirt, grease, asphalt or concrete in order to avoid a bad contact. Remove any asphalt or concrete sticking to the sensor arm by means of an appropriate agent and oil the bearing afterwards.

7.3 How to clean the appliance

Switch off the digital controller

- apply a normal washing-up detergent to a soft, lintfree piece of cloth
- clean appliance surfaces without pressure
- remove the detergent from the appliances with a clean piece of cloth

7.4 Trouble shooting

In spite of extensive protective circuits it is not completely impossible that the functions of the Handset can be affected by the appearance of external disturbances (spikes of the generator, induction voltage etc.). However a Hardware-reset can often eliminate malfunctions. If there is a malfunction act like this:

1. Disconnect the power supply of the Slope Controller.
2. Press the UP- and DOWN-key of the Handset simultaneous and hold them pressed while restoring the power supply.

By this simple process the Handset will be initialized anew. If the malfunctions have not been eliminated yet please repeat the procedure once more.

8. Technical data

Abmessungen (Dimensions):

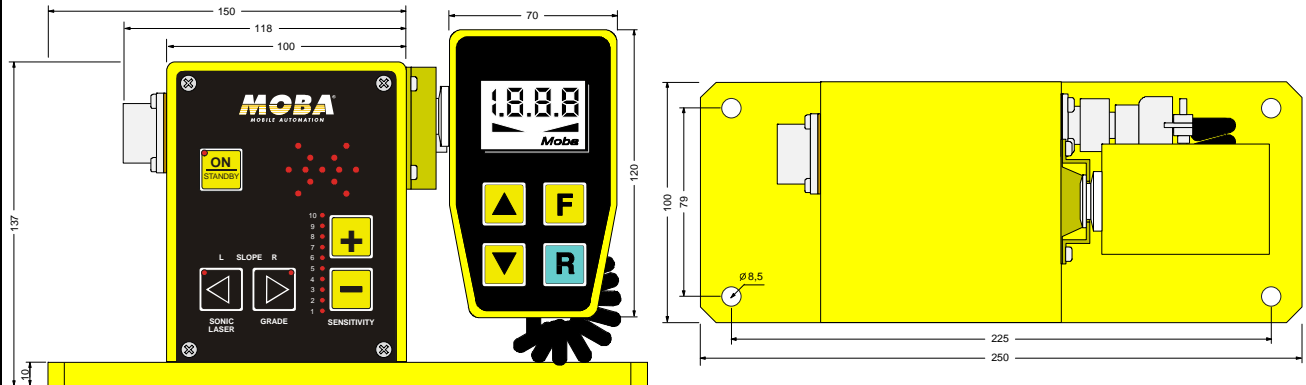

Technische Daten (Technical data):

Betriebsspannung (voltage range):
11 ... 30 V (DC)

Stromaufnahme (current consumption):
< 100 mA ohne Ventile (without valves)

Erfassungsbereich (measuring range):
+/- 10 %

Ausgänge, wählbar (outputs, selectable):
ON/OFF; NPN o. PNP, $I_{max} = 3$ Amp.
Freq. = 3 Hz., MinPuls = 10ms190ms,
Servo, $I_{max.} = 3$ Amp.

Arbeitstemperaturbereich (ambient temperature range):
-20 ... +70 °C

Lagertemperaturbereich (storage temperature range):
-25 ... +80 °C

Schutzart (enclosure protection):
IP 54

Gewicht (weight):
ca. 2,9 kg

Pinbelegung (Pin connection):

7pol. Gerätestecker; Schraubverbindung
(7pin connector; screwed connection)

- A = + Betriebsspannung (supply voltage)
- B = Ausgang "Senken" (output "lower")
- C = - Betriebsspannung (supply voltage)
- D = Ausgang "Heben" (output "raise")
- E = n.c.
- F = Eingang „extern Hand“ (input „valve interruption“).
- G = n.c.

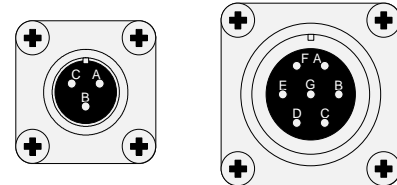

3pol. Gerätestecker; Schraubverbindung
(3-pin plug; screwed connection)

- A = + 8 V
- B = Sollwert (setpoint)
- C = Gnd

Bemerkung (Remark):

Module für Höhen- und Neigungsregelung untereinander austauschbar;
(control modules for grade and slope controlling interchangeable);

9. Declaration of conformance

G 176 plus/S 276 plus/G176 Sonic plus Parameter settings -english-



The text and graphics of this manual have been elaborated with the greatest possible care. However, we may not be held liable for possible errors and failure effects.

Should you wish to make suggestions regarding the arrangement of this manual or point out possible errors, please contact your local dealer. We will gladly take up any of your ingenious ideas and suggestions.

Some company and label names are subject to label-, patent- or trade-mark protection.

All rights reserved. This document must not be duplicated or transferred for any purpose whatsoever without MOBA's written consent, irrespective of the way or the means which are used.

Order-no.: 10-02-00539

Date: 12.2005



MOBA

Mobile Automation AG

Kapellenstr. 15

D-65555 Limburg

Internet: www.moba.de

Index

1. General information	4
2. Call up of the operator menu	5
3. Operator menu	6
3.1 Hydraulic mode	7
3.2 MIN pulse.....	8
3.3 Control window	9
3.4 Default settings	11
4. Short description	12
4.1 Structure diagram	12
4.2 Description of parameters	13

1. General information

All parameters have been factory preset to default values at MOBA. With these defaults a sufficient operation of the most usual types of machines is ensured. Nevertheless it is recommended to optimize each system by adjusting its parameters depending on the specific conditions of the machine.

The parameter settings can be done in manual mode as well as in automatic mode. So the user has got the possibility to optimize his system while working.

2. Call up of the operator menu

The operator menu can be called up from the working mode. That means, it is not relevant if the controller is in manual mode or automatic mode. If the call up is done out of the automatic mode the automatic valve steering from the controller is switched off during this time.

Invocation of the operator menu

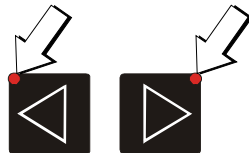
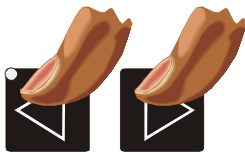

Press both "selection push buttons" simultaneously (2 sec) until their LEDs are on.

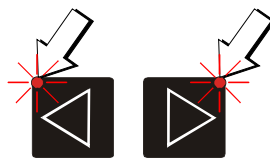
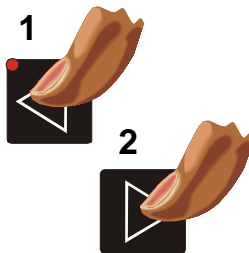

Then within 3 sec. press the following **key combination** (one after the other).

- 1) left selection push button
- 2) right selection push button

Both LEDs start flashing.

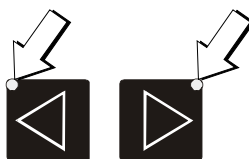

The operator menu can be left any time by pressing the "ON" push button. If no key is pressed the controller automatically switches back to the working menu after max. 60 seconds. Maximally one LED is on.

3. Operator menu

Operator menu

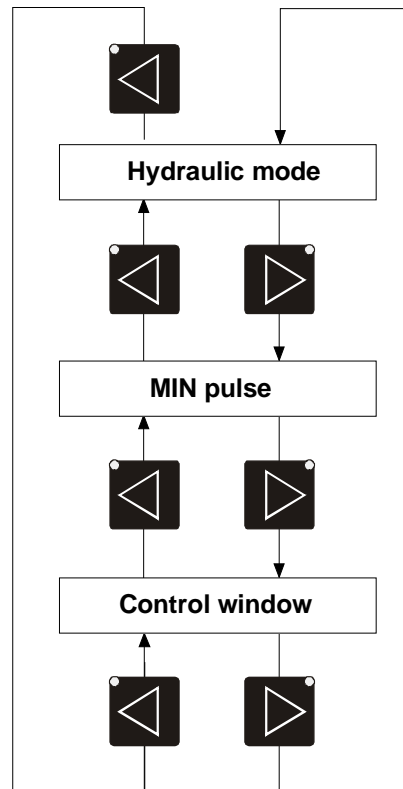
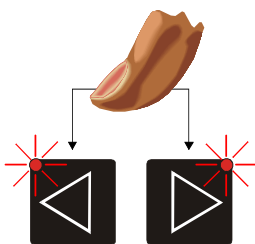

The first section of the operator menu is the "Hydraulic mode". Press the "left/right selection push button" to switch through the parameters.

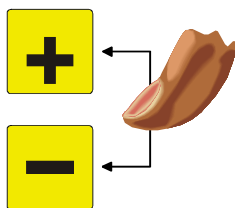

By pressing the "+/-" push button" parameter values can be changed or function modes switched over. The setting you selected is shown by the LED scale.

3.1 Hydraulic mode

The controller has the capability to work with all kind of construction machinery.
The user has the opportunity to adapt the outputs to the machine conditions.

HYDRAULIC MODE

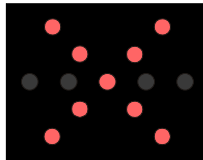

To visualize this section of the operating menu "UP/DOWN Arrow" in the LED display are simultaneously on.

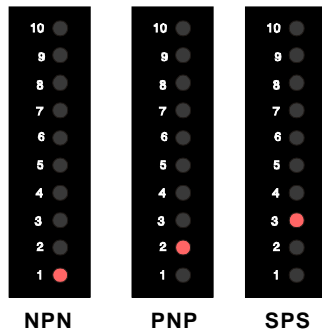
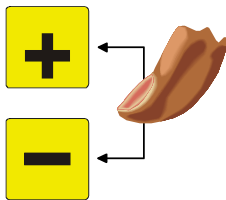

Press "+/- push button" to set the "function mode".

1. **ON/OFF, NPN, 3 Hz** (Default)
2. **ON/OFF, PNP 3 Hz**
3. **ON/OFF, SPS 3 Hz**

The chosen "function mode" is displayed by a assigned LED in the LED scale.

3.2 MIN pulse

Minimum pulse defines the smallest time gap and therefore minimum velocity of the cylinders.

MIN PULSE

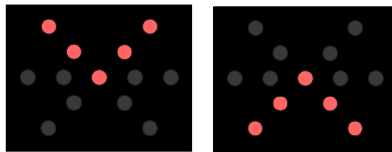

To visualize this section of the operating menu the "UP Arrow" and the "DOWN Arrow" in the LED display is flashing alternately. At the same time occurs an alternating steering of the controller outputs with the set pulse ranges.

Press the "+/- push button" set the "MIN pulse".

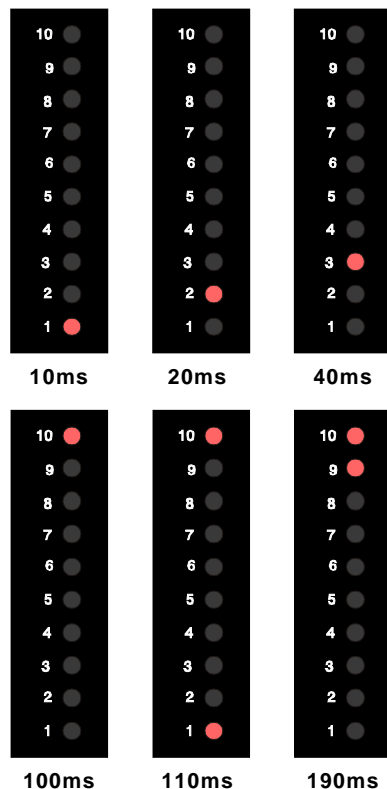
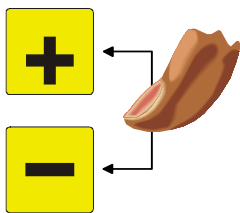

- 1) 10 ms
- 2) 20 ms
- 3) 30 ms
- 4) 40 ms (Default)

.

.

.

- 10) 100 ms
- 11) 110 ms ...

.

.

.

- 19) 190 ms

The set "MIN pulse" is visualized by a LED combination in the LED scale. Above 100 ms, indicated by 10, the values are displayed as a combination of two LEDs limited to 190 ms.

3.3 Control window

This section is for the G 176 plus and the G 176 Sonic plus only.

There are different matters for rapid changes of the controller's measuring value. Reasons are inadvertence of the operators as well as technical mistakes (e.g. torn string line). To avoid these unwanted measuring mistakes with its extreme control actions the set point can be bordered with a so called control window.

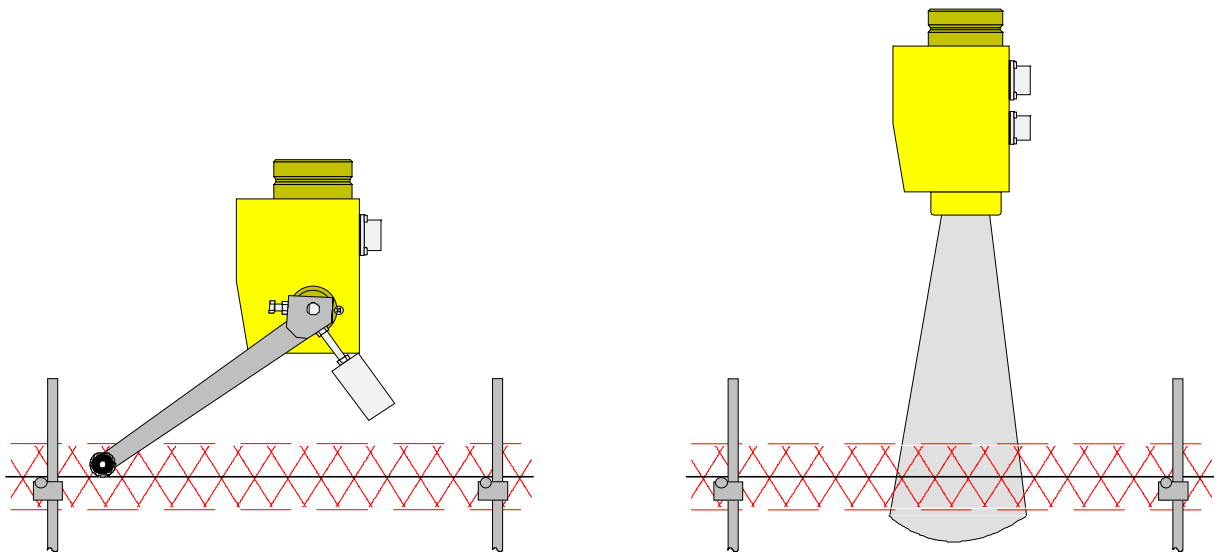

If a control deviation appears that is bigger than a set range this control deviation will be recognised as a fault and the valve steering will be switched off.

CONTROL WINDOW

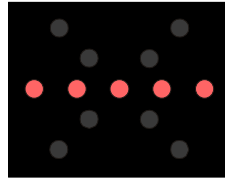

To visualize this section of the operating menu the LED center in the LED display is flashing.

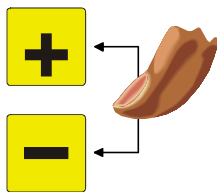

Control window
active,
+/- 3cm



Control window
inactive

Press "+/- push button" to switch between default setting inactive (no LED in the LED scale on) and active (LED "6" in LED scale is on, that means the set point is bordered with a fixed control window about 6 cm = +/- 3 cm)

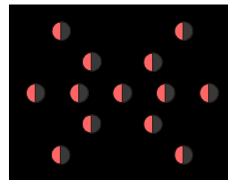

outside of the
control window

If your controller has a control window and the value out of its range in operating mode all LEDs of the LED display are flashing. The valve outputs will be switched off. While working in the control window again the valve outputs will be switched on.

3.4 Default settings

This default settings are factory preset values at the house of MOBA.

DEFAULT SETTINGS



Disconnect the controller from connecting cable to set back default settings.

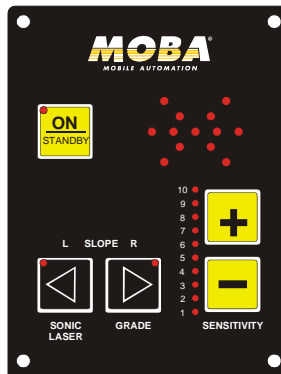
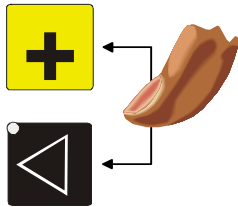

Press "+/- push buttons" simultaneously and hold them.



Connect the Controller to the connector cable to supply the controller with operating voltage. Now unhand the "+/- push button". All settings are set to default. The Controller is ready to operate.

4. Short description

4.1 Structure diagram

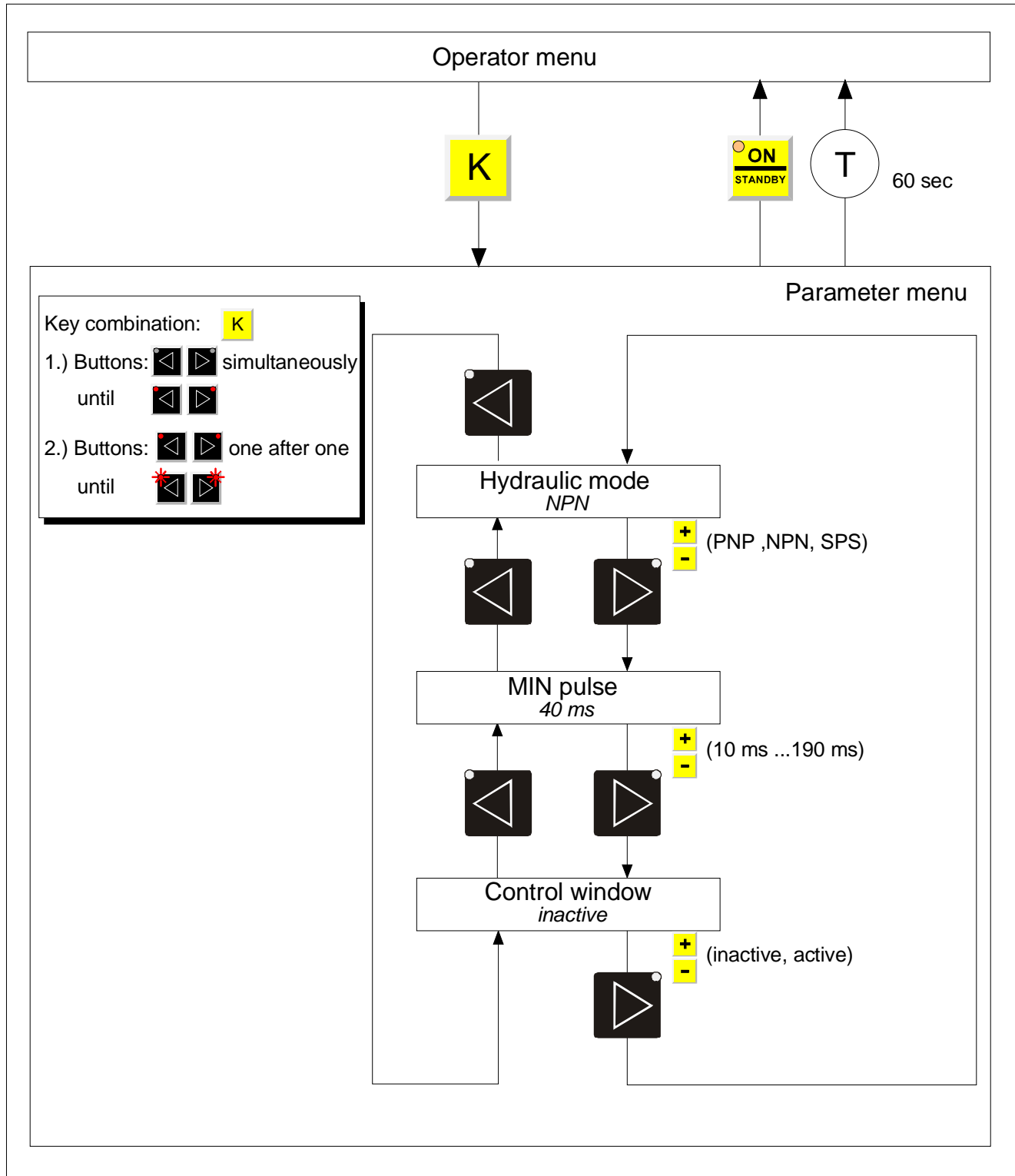

4.2 Description of parameters

Parameter	Default	Range	Description
Hydraulic mode	ON/OFF NPN, 3Hz	ON/OFF, NPN, 3 Hz ON/OFF, PNP 3 Hz ON/OFF, SPS 3 Hz	The G 176 plus maybe used on different machines. The user has the opportunity adapt control valued to these different machines
MIN pulse	40 ms	10 ms 20 ms 30 ms 40 ms . . . 100 ms 110 ms 190 ms	The min pulse defines the shortest time and smallest velocity of the cylinders
Control window	inactive	active inactive	I offset is bigger than control window a failure is assumed and the valves are switched off. For the G 176 plus only.
Default settings			This default settings are factory preset values at the house of MOBA.

