MS4

Mat Smoothness Machine
Operation & Maintenance Manual

To the Owner & Operator

We have tried to provide information which will give you a clear understanding of equipment construction, function, capabilities and requirements. This information is based on the knowledge and experience of highly qualified people at our company and in our field organization. Proper use of this information will promote high efficiency, maximum service life and low maintenance costs.

We strongly recommend that all persons directly involved with this equipment be familiar with this manual.

The information contained in this manual should not be considered all-inclusive for every application. Questions about specific uses of this equipment should be directed to Cedarapids Inc. Anyone who uses this equipment for any purposes other than its intended use assumes the risk of any danger in doing so.

Respectfully,

Cedarapids Inc.



Warning - The operators of this equipment must read, understand, and follow all OSHA, federal, state and local regulations regarding the operation of this equipment. This equipment must be used in accordance with all operation and maintenance instructions.

- (1) Read all decals and instruction signs. Know what guards and protective devices are included and see that each is installed and in operational condition. Additional guards and protective devices may be required and must be installed before operating.
- (2) Never maintain, lubricate or adjust equipment while in operation. Turn off key switch and remove the key before doing any maintenance, lubricating, or adjusting. In some cases it may be necessary to disconnect the battery terminals to prevent accidental starting of the equipment.
- (3) Wear a protective mask whenever harmful air pollution exists.
- (4) Use ear plugs whenever noise level is above established limits.

The following warning applies to Cedarapids equipment supplied with lead-acid batteries:



Warning: Battery posts, terminals and related accessories contain lead and lead compounds, chemicals known to the State of California to cause cancer and reproductive harm.

Wash hands after handling.



Table of Contents

1 -Introduction1
 About Cedarapids Inc.1
 About This Manual1

2 -Safety3
 Hazard Levels3
 Lockout Tagout3
 General safety4

3 -General Information7
 Receiving New Equipment7
 Serial Number Location8
 Specifications9
 Equipment Description10

4 -Lubrication & Maintenance13
 Engine Maintenance & Lubrication (See Engine Manuals) 15
 Hydraulic Reservoir & Filters15
 Hydraulic Oil Level 15
 Hydraulic Suction Strainer 15
 Hydraulic Pump Charge Filter 15
 Elevator Chain & Drive Gearbox16
 Chain Adjustment 16
 Elevator Drive Gearbox Oil 16



Table of Contents

5 -Operating Instructions17

Principle Of Operation17

Know Your Machine17

Engine Control Instrument Panel18

MS-4 Control Panel20

MS-4 Operation22

 Towing Machine by Towing Tongue 22

 Attaching to Paver 23

 Set MS-4 Hopper Gate Limit Switch 25

 Set MS-4 Sonic Switch 26

 Operating the MS-4 27

 Push Beam in Float Mode 28

 Push Beam Hold Mode 28

 Cleaning Machine 28

6 -Schematics29

Electrical29

Hydraulic31

7 -Torque Specifications33

 Standard Torque Chart 34

 Metric Torque Chart 35



About Cedarapids Inc.

1 - Introduction

About Cedarapids Inc.

Cedarapids is proud to manufacture this machine for your use and profit. We also take pride in the quality of our service and replacement parts.

Cedarapids Inc., located in Cedar Rapids, Iowa, USA, has been manufacturing heavy equipment for the construction industry since 1923. Our friendly, helpful personnel are ready and able to serve your needs.

If you have a question, a concern, or just want to talk over an idea about your equipment or application, please feel free to give us a call at (319) 363-3511 or 1-800-821-5600. We look forward to hearing from you.

About This Manual

This manual is an Operation and Maintenance Manual for use by the owner/operator of this equipment.

We strongly recommend that anyone operating or maintaining this equipment become familiar with this manual, whether or not they have experience with this or similar machines.

This manual helps you understand how your machine works, how to operate it properly and how to perform regular maintenance.



Warning - Carefully read this manual before attempting to operate. Failure to follow instructions and warnings contained in this manual can cause severe personal injury or death! It could also cause substantial property damage.

This manual is not to be used to order parts. Only your parts book, identified with your serial number, is a reliable source of accurate part numbers and part descriptions for your machine. When ordering replacement parts, please be as exact as possible in describing the part.

When you have a question about your machine or this manual, please consult your Cedarapids distributor or the Service Department at Cedarapids Inc.



About This Manual

2 - Safety

Hazard Levels

The signal words **Danger**, **Warning** and **Caution** are used to identify hazard levels of in this manual. They may also be found on decals located on the equipment. (Figure 1)

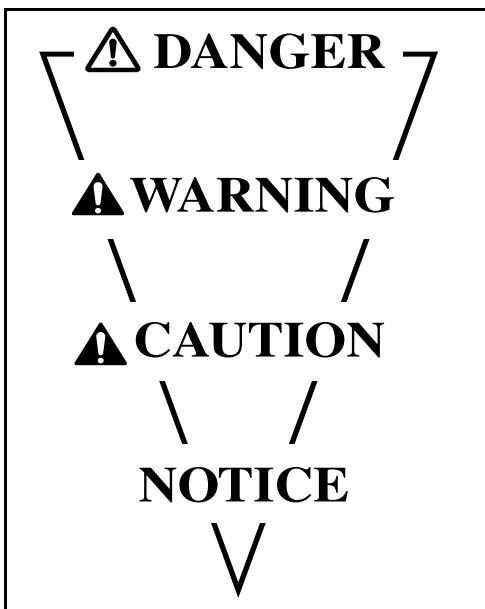

Figure 1 Hazard Level Hierarchy

Definitions for identifying hazard levels and their signal words are provided below:



Danger - Immediate hazards which **WILL** result in death, system loss, severe personal injury, severe occupational illness or severe or major system or environmental damage.



Warning - Hazards or unsafe practices which **COULD** result in death, system loss, severe personal injury, severe occupational illness or severe or major system or environmental damage.

Hazard Levels



Caution - Hazards or unsafe practices which **COULD** result in minor personal injury, minor occupational illness, or minor system or environmental damage.

The signal word **Notice** is used to identify installation, operation, or maintenance information which is important but not hazard related.

Lockout Tagout



Warning - Failure to follow good lockout and tagout procedures could result in serious injury or death.

What is the purpose of lockout /tagout?

- Prevent the unexpected or accidental start-up of equipment and to notify other workers when a piece of equipment is unsafe to operate.
- Prevent injury to personnel from energy that is stored in devices such as springs, accumulators, hydraulic systems, batteries, etc.

How do I lockout and tagout equipment?

- Turn the master key to the OFF position and remove the key.
- Disconnect the batteries.
- Regardless of which lockout method is used, place one or more tags on machine controls or access doors to let other workers know that maintenance is being performed on the machine and/or the machine is unsafe to operate.

Who is responsible for establishing and administering a lockout /tagout program?

- The employer must establish a lockout /tagout system of procedures, training and periodic inspection before any employee operates, services, or maintains a piece of equipment.
- All employees are responsible for seeing that equipment is locked out and tagged out according to the employers policies.

When is lockout and tagout necessary?

- Any time repairs or maintenance on a machine are to be performed.
- When cleaning or lubricating the machine.
- While clearing blocked or jammed mechanisms.
- Any time that the equipment will be left unattended.

Who should apply a lock or tag?

- Any maintenance person who will be working on the equipment.
- The foreman or team leader responsible for the job.
- Anyone who will be working on the equipment.
- If several people will be working on a piece of equipment, each person must apply their own tag.

When can a lock or tag be removed?

- After all safety guards are back in place.
- After work is complete and tools are put away.
- After workers are positioned safely for start-up.

General safety

- After controls are positioned correctly for start-up and machine is operation ready.

Who can remove a lock or tag?

- Only the person who applied a lock or tag can remove it.

General safety

This manual contains important information regarding the operation of your machine. Carefully read the entire manual before attempting to operate.

Danger

- Install all auger guards and covers before operating.
- Never attempt to install or remove any part or assembly when the machine is running.
- Do not allow personnel to stand or walk between the front of the machine and the back of the truck while machine is operating.
- Attach safety cables or lower machinery before performing any inspections, repairs or adjustments.
- All guards and protective devices must be in place when the machine is being operated or moved.
- Keep all personnel clear of augers or conveyors when the machine is operating.
- Do not refuel the machine with the engine or d heater system running. All sparks and open flames must be kept a minimum of 50 feet away from machine when refueling.
- Do not wash or spray down the machine with heater system operating.

General safety

Warning

- Do not operate this equipment until you have been trained in its operation or maintenance. This equipment may only be operated or maintained by trained personnel, who have demonstrated their ability to do so safely.
- Keep this manual for future reference.
- Read, understand and follow all current OSHA, federal, state and local regulations that are applicable to your job and equipment.
- This equipment must be used in accordance with all operation and maintenance instructions.
- All persons involved with this equipment must be familiar with this manual.
- Read, understand, and follow all Danger, Warning, Caution and instruction decals in this book and on the machine.
- When changing the configuration or adding equipment, all additional guards associated with the added equipment must be installed before operating or moving.
- Any changes made to the original design of the machine must be approved by qualified personnel to ensure that the changes include appropriate guarding and provide a safe working environment for all personnel.
- Wear clothing that fits snug to prevent getting caught in moving parts. Loose-fitting clothing should never be worn.
- Mount and dismount the machine using only the steps, handrails and walkways provided.
- Do not mount the machine when it is moving.
- Allow only the operator on the operator's platform when the machine is in operation.

- Before starting engine, make sure all other systems are OFF and all personnel are clear.
- Do not allow personnel near the hopper area when machine is running.

Caution

- Wear protective mask when harmful air pollution exists.
- Wear safety goggles, gloves and long-sleeve shirts when working near hot asphalt materials.
- Wear ear plugs while machine is running.
- Keep operator's platform, steps and walkways clear of all obstructions, tools and other items to prevent tripping or falling.
- To prevent fire hazards, keep the machine free of oil, asphalt and trash buildup.



General safety

Receiving New Equipment

3 - General Information

Receiving New Equipment

Before accepting and unloading a new machine, the consignee must inspect the equipment for evidence of damage or missing parts. This inspection process should be thorough, because once the freight receipt is signed, it is assumed that all of the equipment listed on the receipt was received in good condition.

Make a thorough inventory of all loose components packaged in boxes. A check list is provided in each box listing the components in the box. While performing the inventory, inspect all loose components for damage which may have occurred during transit. Any damage that happens to the equipment in transit is the responsibility of the carrier **not** Cedarapids. Claims for damage must be submitted to the carrier for settlement.

When evidence of damage or loss is discovered, have the driver make a notation on both the carrier's and consignees' copies of the freight bill. Prior to signing the freight bill, take pictures of the damage and identify the truck if possible. The consignee can then sign the bill to acknowledge delivery. The consignee should then have the carrier's terminal manager or his authorized representative make an official inspection of the damage or loss.

Equipment should not be moved from the original receiving point until this official inspection has been made. Good clear photos will verify and explain damage in any claim action which may follow. When the inspection is done, the consignee

should file a written damage claim with the carrier's office and should report this action to the area distributor for Cedarapids Inc.

If hidden damage is found after the carrier's representative has gone, do not continue to unpack or move the equipment. Contact the carrier's local office and have the terminal manager or authorized representative make an immediate personal inspection of the damage. Obtain a written description of the damage, and photos if possible, signed by the representative as proof of a valid claim.

A packet of equipment warranty/start-up information will be sent to the distributor before the equipment leaves the factory. All warranty/start-up forms must be filled out and returned to Cedarapids within **24 hours** after the equipment is received.

Serial Number Location

Serial Number Location

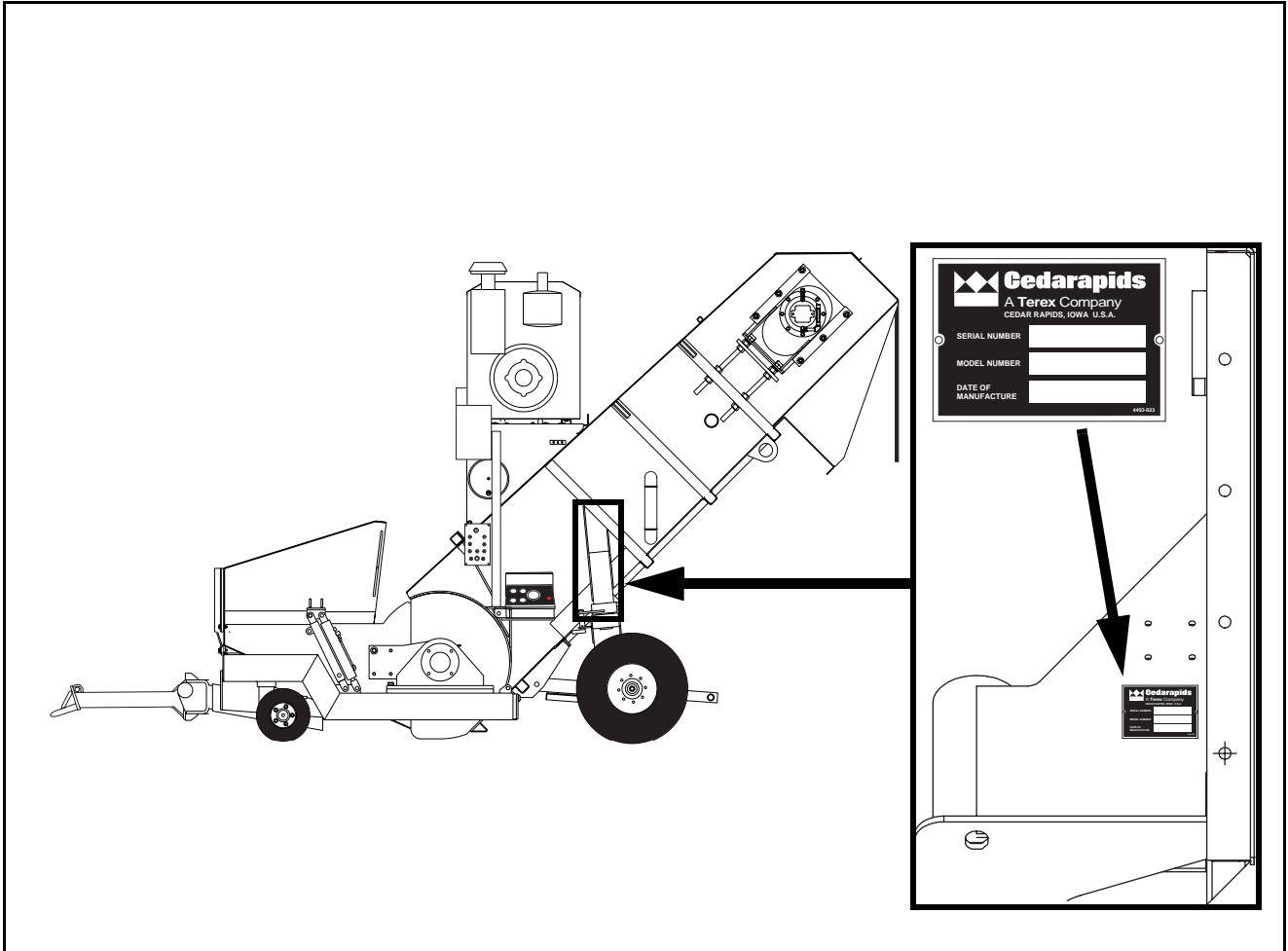
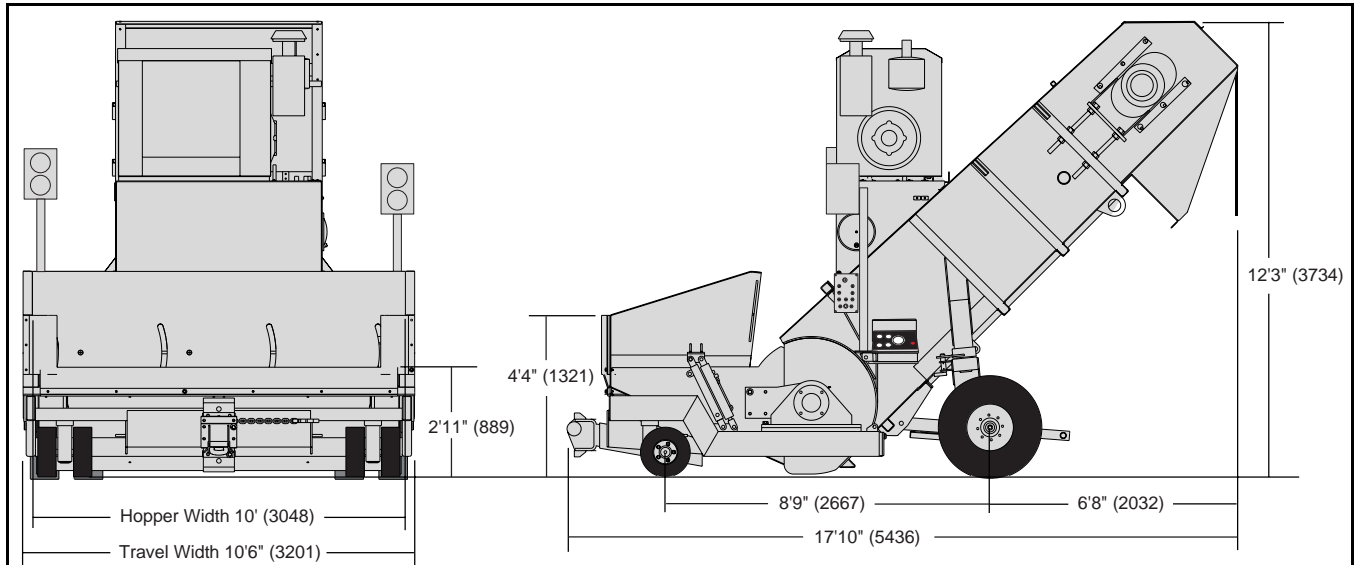

Figure 2 MS-4 Serial Number Location

The serial number plate for the MS-4 can be found on the left rear frame bulkhead. In addition, the serial number will be stamped into the bulkhead near the serial number plate. (Figure 2)

Specifications

Specifications



Weight (approx).....22,500 lbs (10,206kg)
 Capacity (max - theoretical)..2060 tph (1870 tonnes/hr)
 Hopper capacity.....100 ft³ (1.7 m³)
 John Deere 4045T engine.....100 hp @ 2000 rpm
 Front tires (4).....18" x 9" (457 x 229 mm) solid
 Rear tires (4).....8.25 x 15, 18-ply
 Blending auger39" diameter

Elevator
 Width.....60" (1524 mm)
 Bolt-on flights.....6" x 4" x 1/2" (152 x 102 x 13 mm)
 B1 roller chain.....5.51" pitch
 High alloy liners.....3/8"(10mm)

Equipment Description

Equipment Description

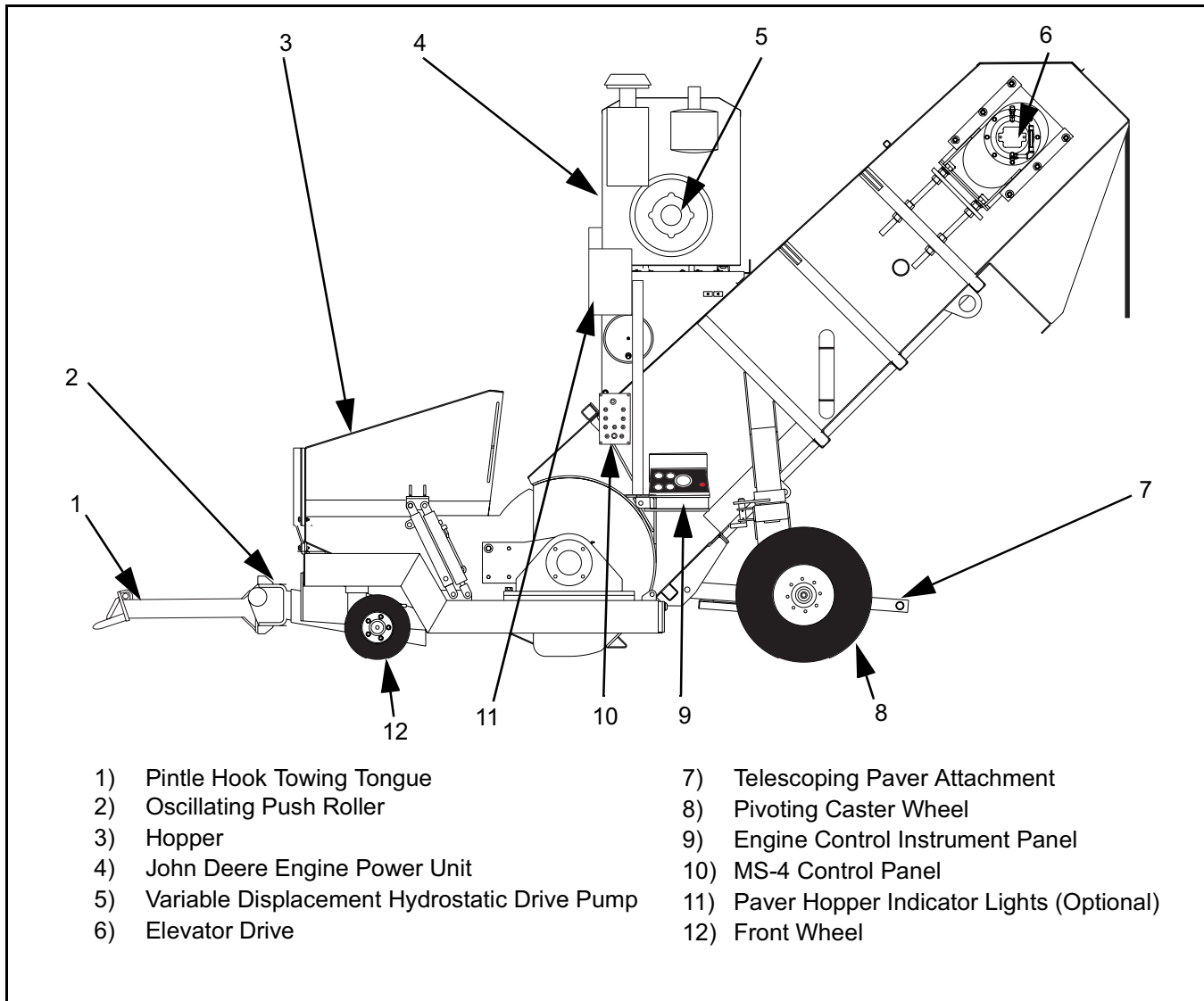

Figure 3 MS-4 Mat Smoothness Machine



Equipment Description

- 1) Pintle Hook Towing Tongue (Removable) - Used to tow machine to and from job site and position onto paver.
- 2) Oscillating Push Roller - Used to push trucks ahead of MS-4 while unloading into machine.
- 3) Hopper - Hot mix asphalt receiving hopper.
- 4) John Deere Engine Power Unit - Model 4045T Turbocharged diesel engine.
- 5) Variable Displ. Hydrostatic Drive Pump - Provides hydraulic power to drive the elevator.
- 6) Elevator Drive - Hydraulically driven gearbox (one on each side) that drives asphalt elevator.
- 7) Telescoping Paver Attachment - Attaching mechanism to couple the MS-4 to the paver.
- 8) Pivoting Caster Wheel - Main support wheels for machine. Are locked in fixed position for transport and towing and swivel while operating.
- 9) Engine Control Instrument Panel - Engine monitoring instrument panel. Also contains optional light switch, spraydown switch, emergency shut-down switch, and electrical circuit breakers.
- 10) MS-4 Control Panel - Contains switches to control engine and MS-4 functions.
- 11) Paver Hopper Indicator Lights (Optional) - Red and green indicator lights used to communicate to truck driver(s) a status of the asphalt level in the paver hopper.
- 12) Front Wheel - Solid rubber front wheels support the front of machine including receiving hopper.



Equipment Description

4 - Lubrication & Maintenance

Lubrication & Maintenance

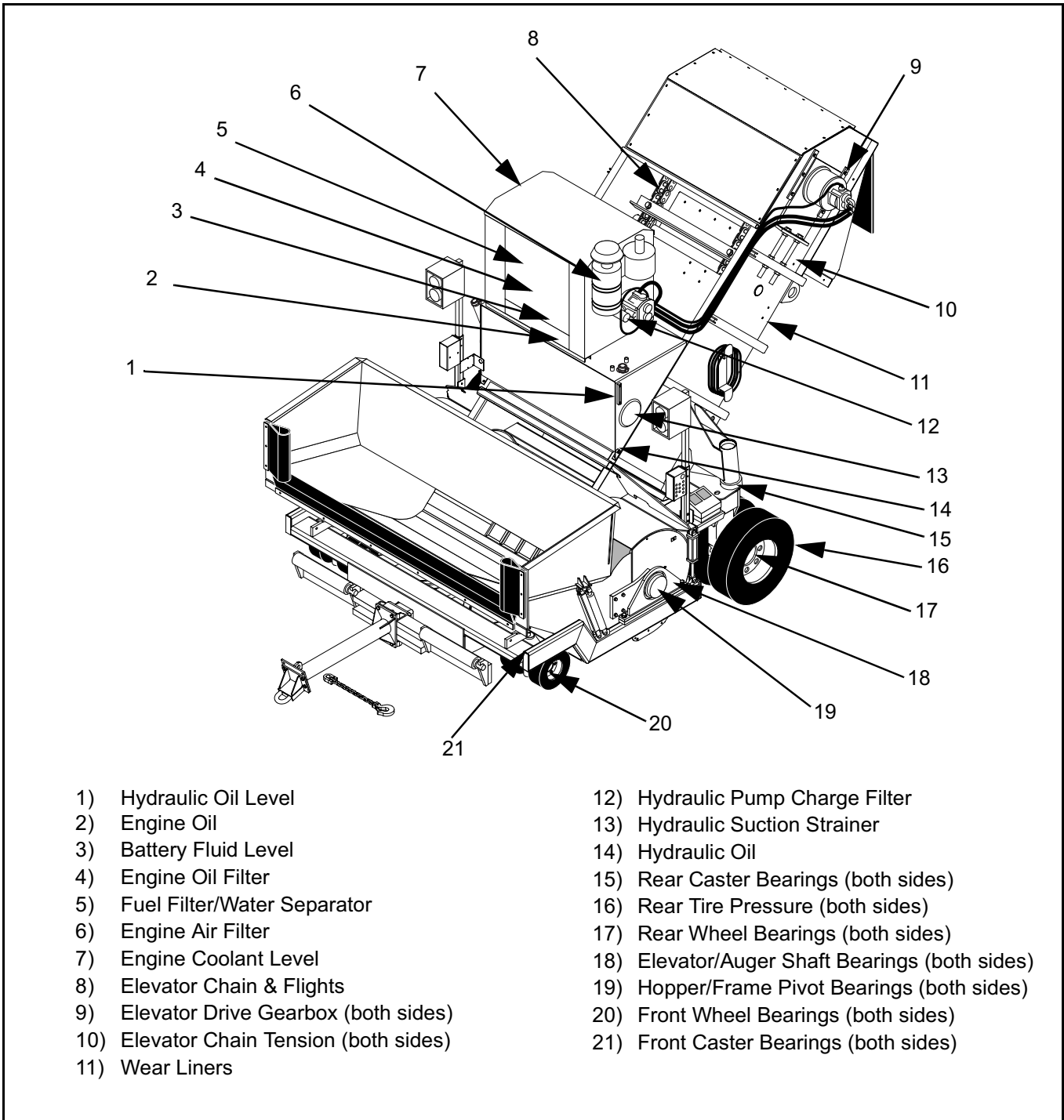

Figure 4 MS-4 Lubrication & Maintenance Locations



Lubrication & Maintenance

Interval Hours	Ref. No.	Identification	Type of Service	Service Points	Lubricant
10	7	Engine Coolant Level	Check	1	
	2	Engine Oil Level	Check	1	EO
	5	Fuel Filter/Water Separator	Drain	1	
	1	Hydraulic Oil Level	Check	1	AW
	18	Elevator/Auger Shaft Bearings	Lube	2	MPG
	8	Elevator Chain & Flights	Clean		
50	9	Elevator Drive Gearboxes	Check	2	MPL
	16	Rear Tire Pressure (120 PSI)	Check	4	
	10	Elevator Chain Tension (6"-8" sag)	Check	2	
100	6	Engine Air Filter	Check	1	
	3	Battery Fluid Level	Check	1	
250	4	Engine Oil Filter	Change	1	
	2	Engine Oil	Change	1	EO
500	5	Fuel Filter/Water Separator	Change	1	
1000	12	Hydraulic Pump Charge Filter	Change	1	
	13	Hydraulic Suction Strainer	Change/Clean	1	
	14	Hydraulic Oil	Change	1	AW
	9	Elevator Drive Gearboxes	Change	2	MPL
	17	Rear Wheel Bearings	Lube	4	MPG
	20	Front Wheel Bearings	Lube	4	MPG
	15	Rear Caster Bearings	Lube	2	MPG
	21	Front Caster Bearings	Lube	2	MPG
	11	Wear Liners	Check		
	7	Engine Coolant	Change	1	

Lubricant Key

EO = Engine Oil

AW = Premium Anti-wear Hydraulic Oil

MPG = Multipurpose Grease

MPL = Multipurpose Gear Lubricant

Hydraulic Reservoir & Filters

Engine Maintenance & Lubrication (See Engine Manuals)

Hydraulic Reservoir & Filters

Hydraulic Oil Level

Check the hydraulic reservoir oil level daily with the machine sitting on flat, level ground. The correct oil level is at the full cold mark when the machine is cold or full hot mark when machine is at normal operating temperature (Figure 5).

Notice - Filling to the full hot mark when machine is cold may result in oil forced out the breather when machine is at operating temperature.

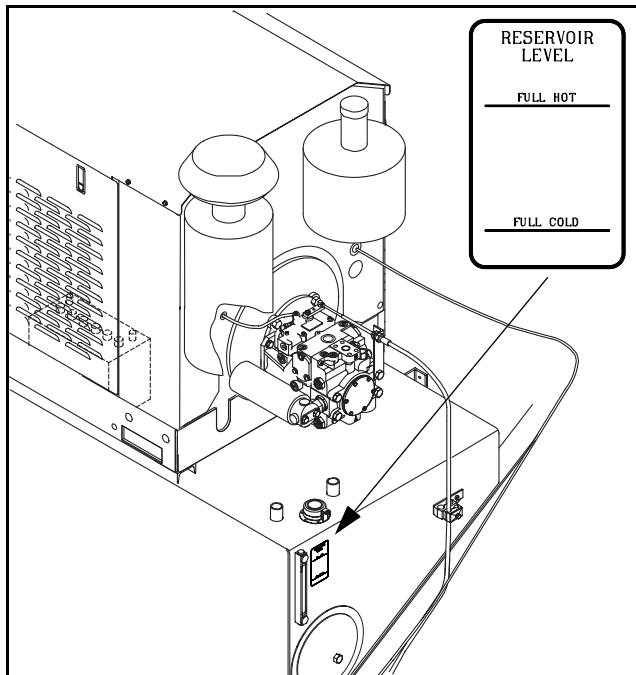

Figure 5 Hydraulic Oil Level

Hydraulic Suction Strainer

The hydraulic oil should be drained and replaced with the correct fluid every 1000 hours of operation. The suction strainer located inside the reservoir should be removed and cleaned when the hydraulic oil is replaced (Figure 6).

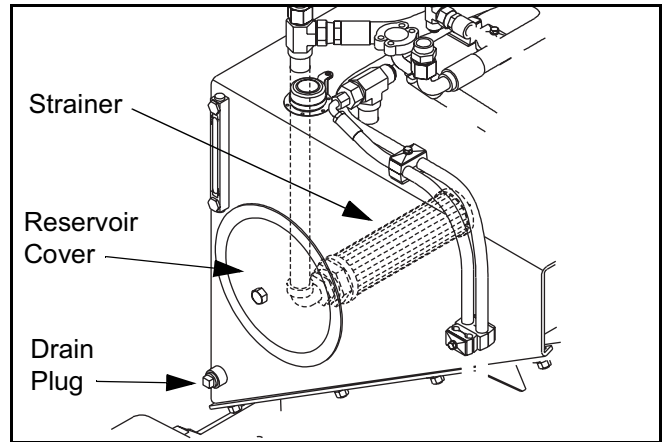

Figure 6 Hydraulic Suction Strainer

Hydraulic Pump Charge Filter

The hydrostatic drive pump on rear of engine has a high pressure charge filter for the conveyor system. This filter should be replaced every 1000 hours of operation

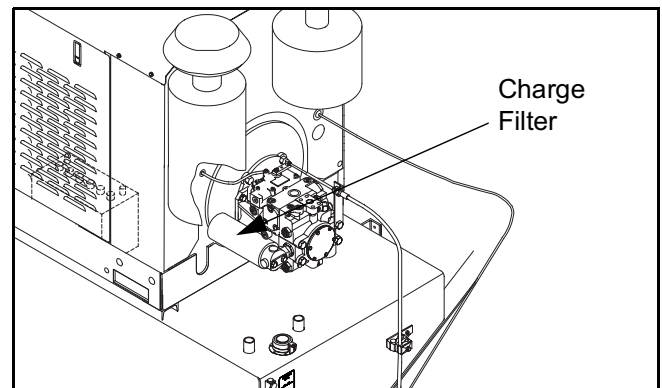

Figure 7 Hydraulic Pump Charge Filter

Elevator Chain & Drive Gearbox

Elevator Chain & Drive Gearbox

Chain Adjustment

The elevator chains should be checked using a string line placed from the lower head shaft to the drive sprocket as shown in (Figure 8).

To adjust, loosen the adjuster nuts closest to the drive gearbox to loosen the chain or tighten the adjuster nuts closest to the drive gearbox to tighten the chain. Once the correct adjustment range is achieved, tighten the nuts to lock in place. Repeat for the opposite side.

Notice - Make sure both sides are adjusted the same. Failure to do so will cause increased wear.

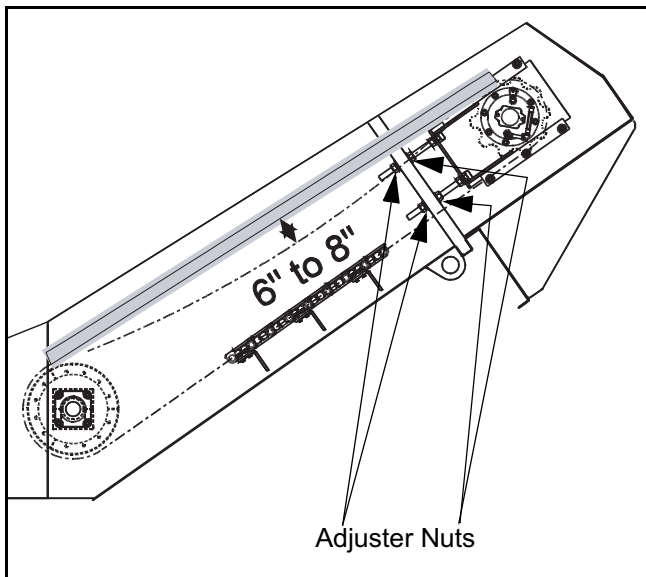

Figure 8 Elevator Chain Adjustment

Elevator Drive Gearbox Oil

The elevator drive gearbox oil level should be checked daily. The level should be half way up the sight gauge. This is for both sides (Figure 9).

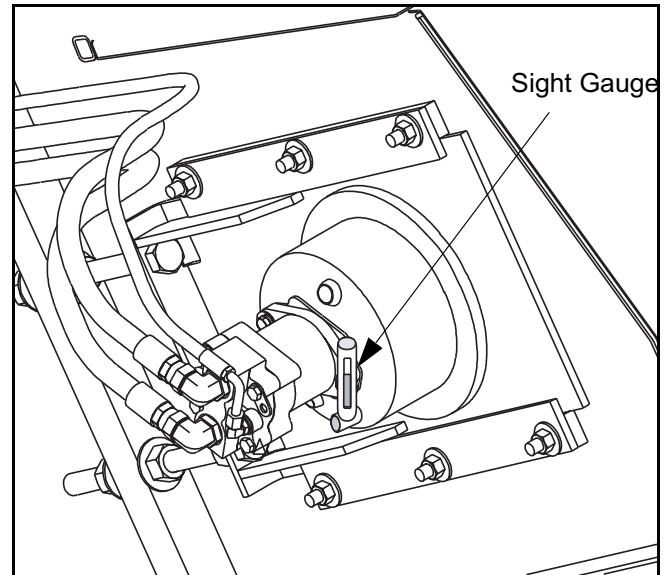

Figure 9 Elevator Gearbox Oil Level

Principle Of Operation

5 - Operating Instructions

Principle Of Operation

The MS-4 Mat Smoothness Machine used in combination with an asphalt paver transfers hot mix asphalt from transport truck to the paver allowing continuous, non-stop paving.

The MS-4 is towed to the job site, connected to the paver and propelled by the motion of the paver. The MS-4's engine provides power to operate the auger and elevator drive as well as all other hydraulic functions on the machine.

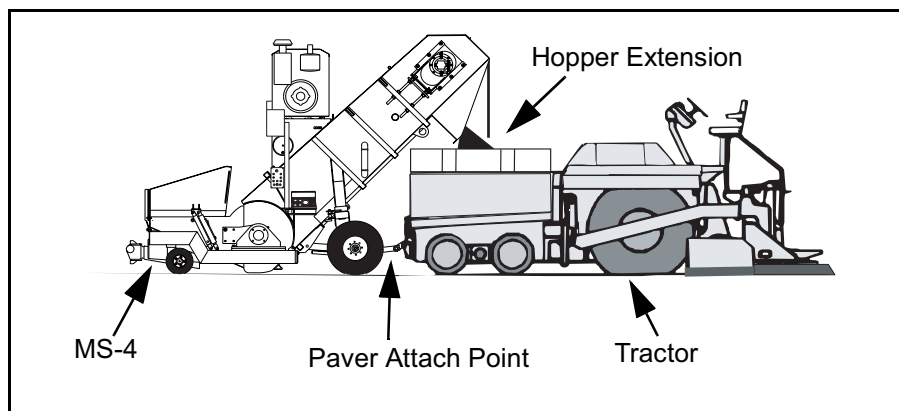

Figure 10 Asphalt Flow

Know Your Machine

Basic recommendations and suggestions are contained in this manual. Read this manual and engine manuals furnished with your machine for complete information.

Become familiar with all controls on your machine. The following pages illustrate and explain controls and functions of the MS-4 Mat Smoothness Machine.

Engine Control Instrument Panel

Engine Control Instrument Panel

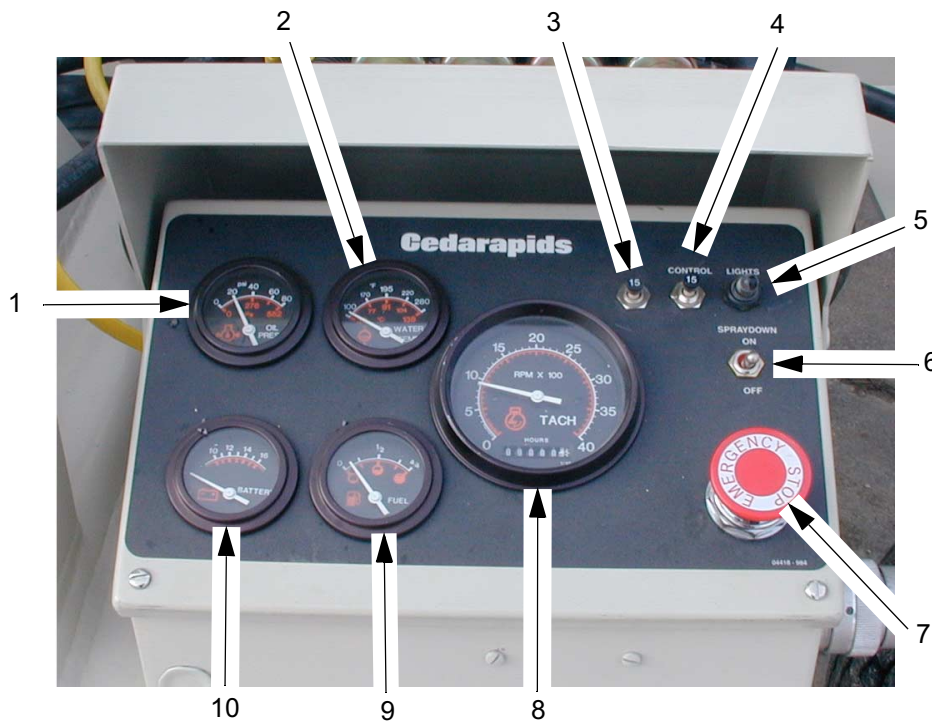

- | | |
|--|---------------------------------|
| 1) Engine Oil Pressure Gauge | 6) Spraydown Switch |
| 2) Engine Coolant Temperature Gauge | 7) Emergency Stop Switch |
| 3) Paver Hopper Indicator Light
Circuit Breaker/Switch (Optional) | 8) Engine Tachometer/Hour Meter |
| 4) Main Machine Controls Circuit Breaker/Switch | 9) Fuel Level Gauge |
| 5) Flood Light Circuit Breaker/Switch (Optional) | 10) Voltmeter |

Figure 11 Engine Control Instrument Panel



Engine Control Instrument Panel

- 1) Engine Oil Pressure Gauge - Registers engine oil pressure.
- 2) Engine Coolant Temperature Gauge - Registers engine coolant temperature.
- 3) Paver Hopper Indicator Light Circuit Breaker/Switch (Optional) - Protects optional indicator light electrical circuit. Used to turn circuit power on and off.
- 4) Main Machine Controls Circuit Breaker/Switch - Protects all machine controls electrical circuits. Allows circuit power to be turned on and off.
- 5) Flood Light Circuit Breaker/Switch (Optional) - Protects the optional flood light circuit. Used to turn circuit power on and off.
- 6) Spraydown Switch - Controls fuel pump used to clean machine.
- 7) Emergency Stop Switch - Switch shuts off engine and all electrical components except lighting.
- 8) Engine Tachometer/Hour Meter - Registers engine RPM and number of hours engine operates.
- 9) Fuel Level Gauge - Registers level of fuel in tank.
- 10) Voltmeter - Registers battery voltage level.

MS-4 Control Panel

MS-4 Control Panel

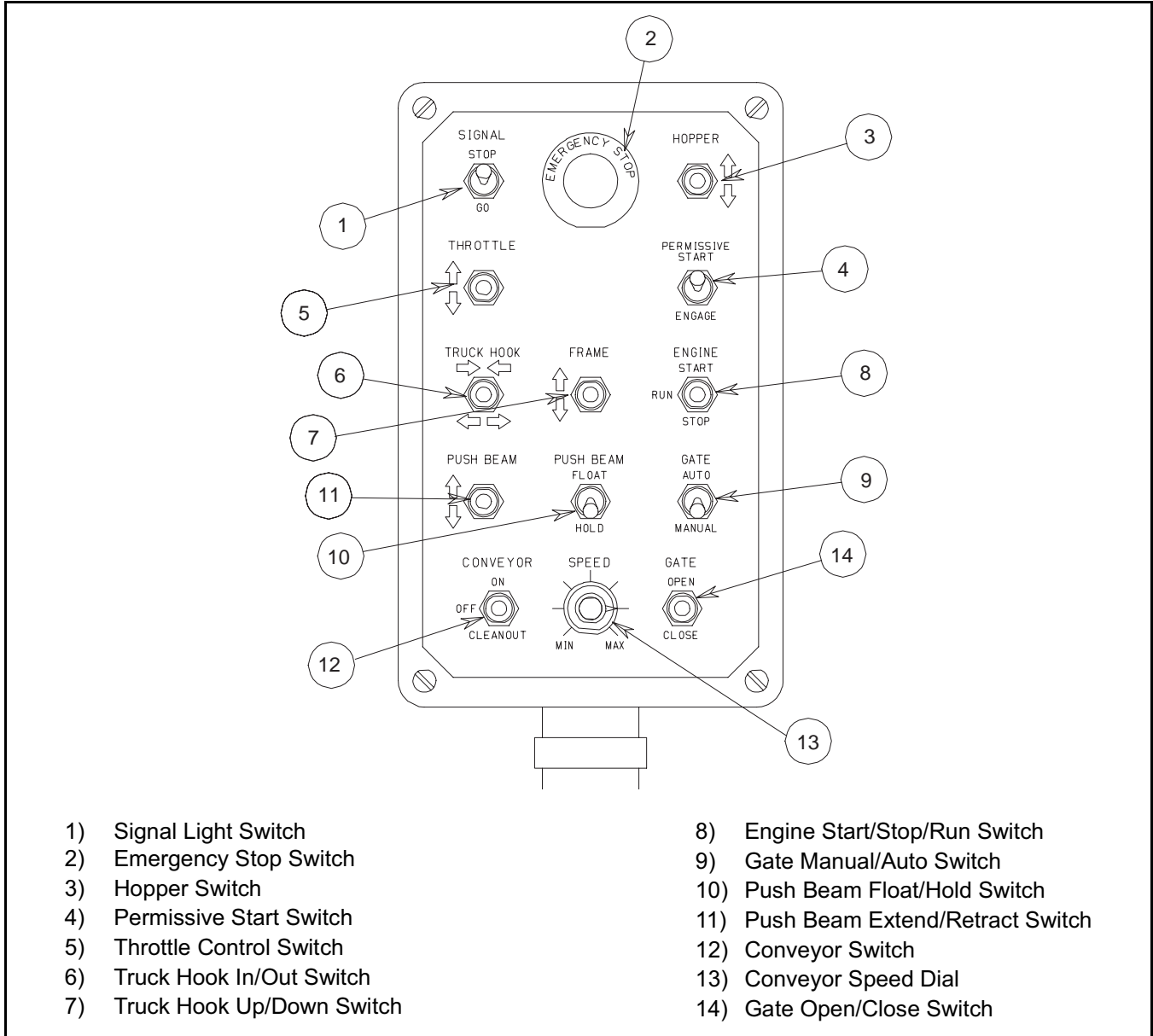

Figure 12 MS-4 Control Panel

- | | |
|---|---|
| <p>1) Signal Light Switch - 3 position switch allows manual or automatic operation of optional Paver Hopper Indicator Lights.
Center Position - Lights in automatic mode (controlled by sonic switch)
Stop Position - Red indicator light lit.
Go Position - Green indicator light lit.</p> | <p>2) Emergency Stop Switch - Switch shuts off engine and all electrical components except lighting.</p> <p>3) Hopper Switch - Raises and lowers MS-4 receiving hopper.</p> |
|---|---|

MS-4 Control Panel

- 4) Permissive Start Switch - When engaged, provides electrical power to fuel solenoid for starting engine when oil pressure is at 0 PSI.
- 5) Throttle Control Switch - 3 position switch allows control of engine throttle.
Center Position - Holds throttle setting.
Up Position - Jogs engine RPM higher.
Down Position - Jogs engine RPM lower.
- 6) Truck Hook In/Out Switch - 3 position switch allows control of truck hook.
Center Position - Holds truck hook in position.
In Position - Moves truck hook in to engage into truck wheels.
Out Position - Moves truck hook out to disengage from truck wheels.
- 7) Frame Up/Down Switch - 3 position switch allows control of MS-4 frame.
Center Position - Holds frame setting.
Up Position - Raises machine frame.
Down Position - Lowers machine frame.
- 8) Engine Start/Stop/Run Switch - 3 position switch allows engine ignition control.
Stop Position - Stops engine and shuts off all electrical power to engine.
Start Position - Engages starter to start engine. (spring returns to Run when released)
Run Position - Allows engine to operate in this position.
- 9) Gate Manual/Auto Switch - 2 position switch allows manual or automatic operation of MS-4 hopper gate.
Manual Position - Allows gate to be operated by Gate Open/Close Switch (14).
Auto Position - Allows gate to be controlled by sonic switch. Gate closes when paver hopper is indicated "Full" and opened when paver hopper level drops.
- 10) Push Beam Float/Hold Switch - 2 position switch allows push beam to float or hold in position.
Float Position - Energizes a hydraulic valve to allow push beam cylinders to retract slowly when truck makes contact.
Hold Position - Does not allow push beam cylinders to retract when truck makes contact. (Cylinders are cushioned by accumulators)
- 11) Push Beam Extend/Retract Switch - 3 position switch allows extension and retraction of push beam.
Extend (Up) Position - Extends push beam cylinders moving beam outward from MS-4.
Retract (Down) Position - Retracts push beam cylinders moving beam inward toward MS-4.
- 12) Conveyor Switch - 3 position switch allows control of MS-4 elevator.
On Position - Allows elevator to run in forward moving material to the paver.
Cleanout Position - Allows elevator to be run in reverse to remove a plugging condition.
Off Position - Shuts off MS-4 elevator. (Switch must be Off to start engine)
- 13) Conveyor Speed Dial - Dial allows speed control of MS-4 elevator drive.
Min. - Slowest speed.
Max. - Fastest speed.
- 14) Gate Open/Close Switch - 3 position switch allows manual control of MS-4 hopper gate when energized by Gate Manual/Auto Switch (9).
Open Position - Opens hopper gate opening.
Close Position - Closes hopper gate opening.
Center Position - Holds hopper gate position.

MS-4 Operation

MS-4 Operation

Towing Machine by Towing Tongue



Warning - Do not tow machine more than 20 miles per hour.



Caution - Check all wheel lugs for tightness after 20 miles travel. Recheck after 100 miles. Check frequently when equipment is being moved extended distances.

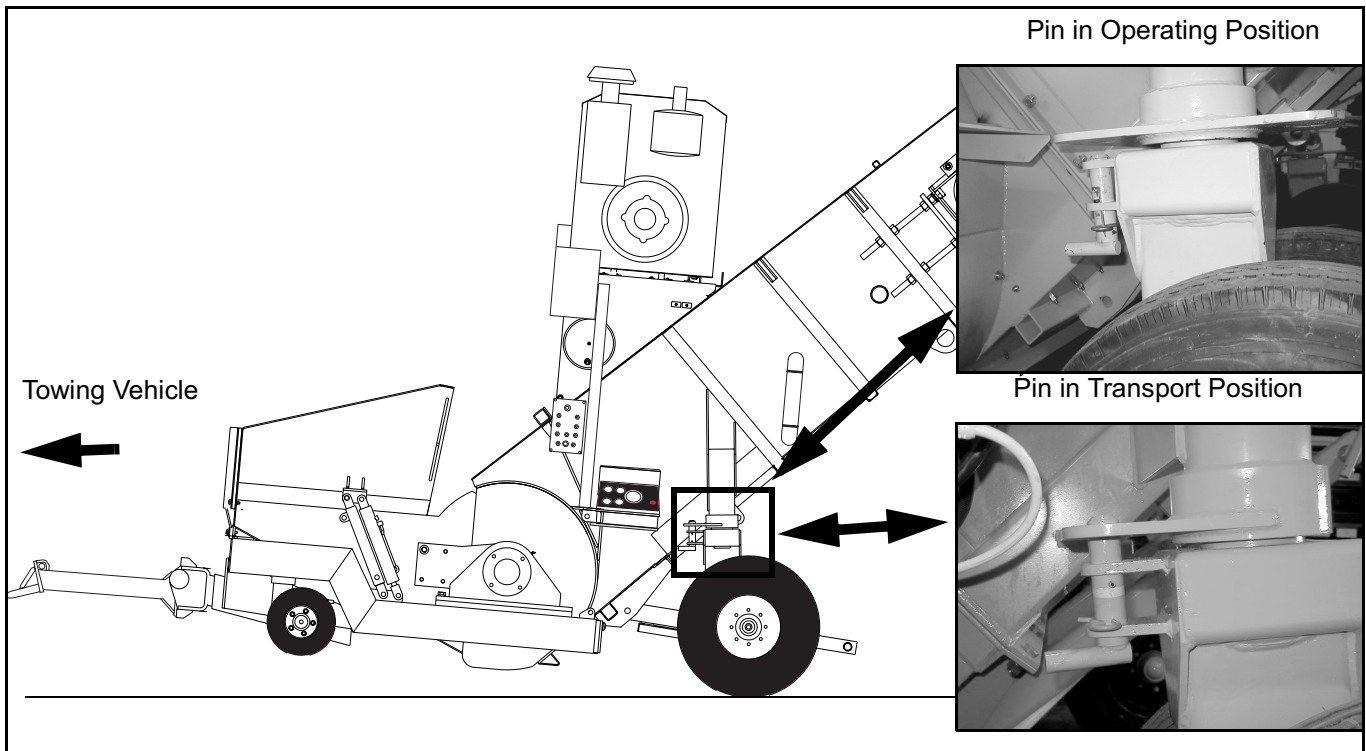

Figure 13 Towing MS-4

- 1) Pin rear pivoting caster wheels in the transport position (Figure 13).
- 2) Raise hopper and lock in place.
- 3) Retract push beam or truck hook and install transport pin.
- 4) Install towing tongue.
- 5) Raise towing tongue to a position that will allow proper ground clearance once machine is hooked to towing vehicle. Do this by using frame raise control.
- 6) Position towing vehicle.
- 7) Lower machine onto towing vehicle's hitch and raise front wheels off the ground to provide clearance.
- 8) Shut off engine.
- 9) Secure hitch and attach safety chains.

MS-4 Operation

Attaching to Paver

- 1) Install machine attachment brackets on paver push beam or truck hook as shown in instructions (Figure 14).



Warning - Always place blocking in front and behind tires of machine when not attached to a towing vehicle or paver to prevent it from rolling or moving.

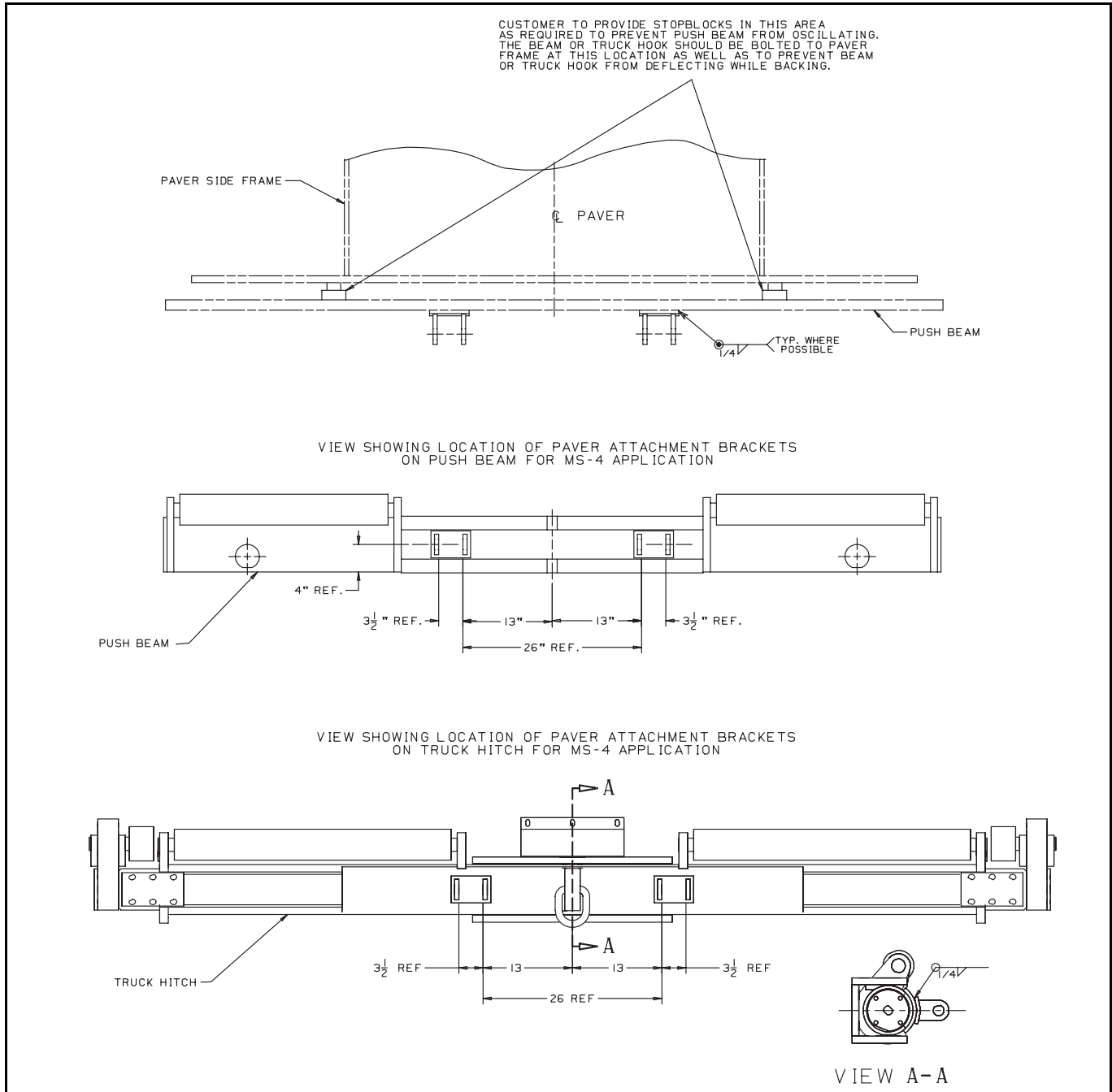

Figure 14 Installation of Paver Attachment Brackets

MS-4 Operation



Danger - Do not allow any personnel between machine and paver when paver is being moved and aligned with push arms.

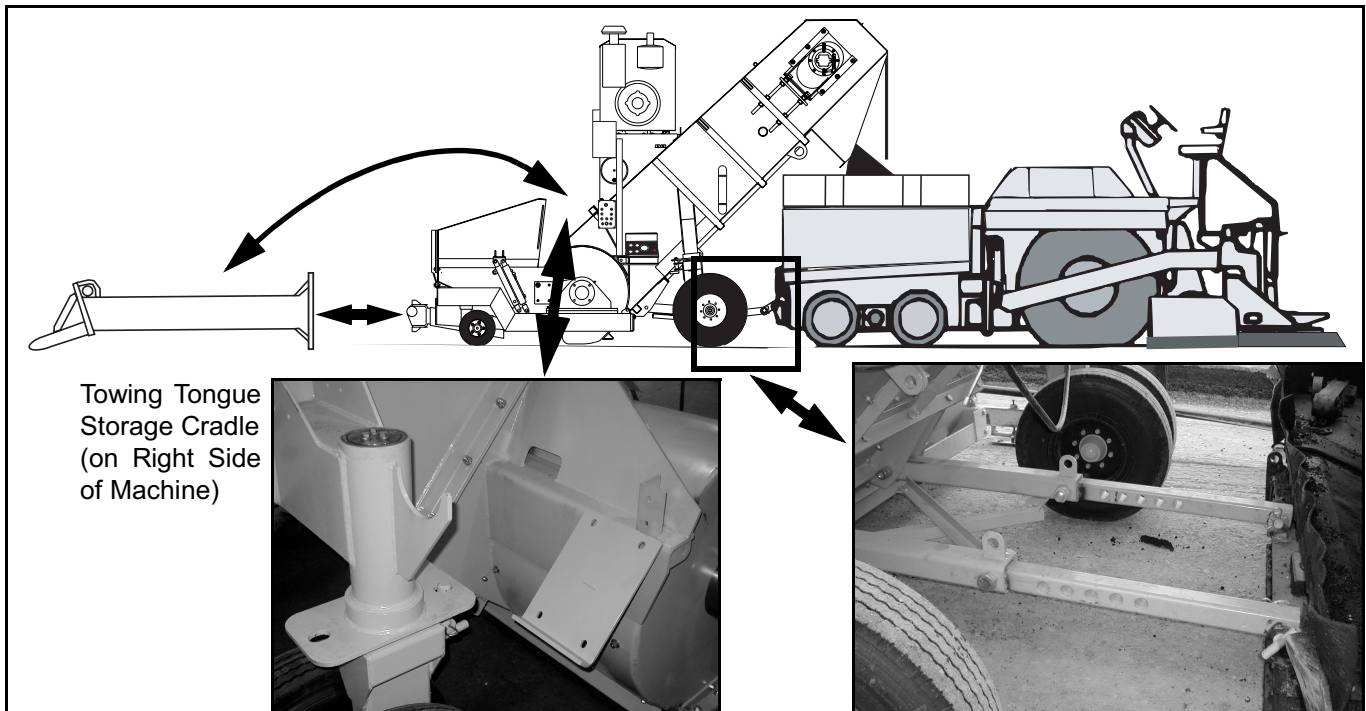

Figure 15 Attach MS-4 to Paver

- 2) Disconnect machine push arm assembly from transport position and block up to same height as attachment brackets on the front of paver.
- 3) Remove push arm pins so arms can be extended or retracted.
- 4) Align paver with machine by moving paver so discharge chute is approximately 1' to 2' inside paver hopper.
- 5) Lock paver brakes and shut off engine.
- 6) Extend push arms into attachment brackets on paver.
- 7) Install and tighten retainer bolts.
- 8) Start paver, release brakes and move forward or reverse to align holes in push arms so retainer pins can be reinstalled.
- 9) Lock paver brakes and shut off engine.
- 10) Install push arm retainer pins.
- 11) Remove transport lock pins from rear caster wheels to allow them to pivot (Figure 13).
- 12) Remove towing tongue and fasten into storage cradle on right side of machine (Figure 15).
- 13) Remove push beam or truck hook transport pin.

MS-4 Operation

Set MS-4 Hopper Gate Limit Switch

Refer to (Figure 12) for controls and (Figure 16) below to adjust the hopper gate switch to limit the maximum opening. Make this adjustment before starting to operate the machine on a job.

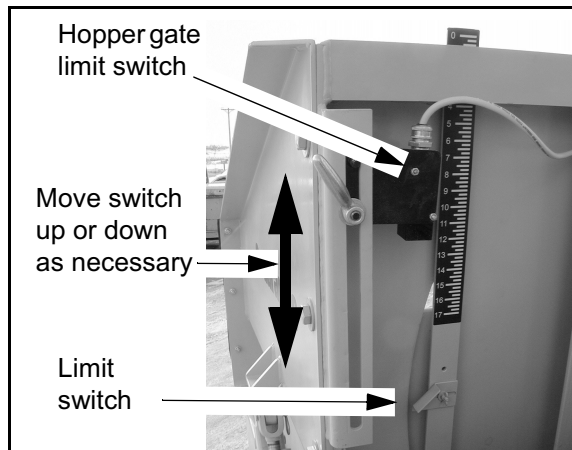

Figure 16 Hopper Gate Limit Switch Adjustment

- 1) Secure all machine-to-paver attachment points.
- 2) Inspect fluid levels.
- 3) Set Conveyor Speed Dial to Min.
- 4) Set Conveyor Switch to Off.
- 5) With Engine Start/Stop/Run Switch in Run position, jog Throttle Control Switch to Down to make sure engine throttle will be at idle.
- 6) Advise personnel of start up.
- 7) Move Permissive Start Switch to Engage position and hold while moving Engine Start/Stop/Run Switch to Start position until engine starts.

Notice - If engine does not start in 30 seconds, allow starter to cool before trying again.

- 8) Once engine starts, release Start/Stop/Run Switch and continue to hold Permissive Start Switch for approximately 15 seconds or until oil pressure is established.
- 9) Verify correct engine oil pressure and other engine gauge readings. (Consult engine owner's manual)
- 10) Move Gate Manual/Auto Switch to Manual.
- 11) Move Gate Open/Close Switch up or down to open gate to desired maximum height.
- 12) Loosen limit switch retaining nut and slide switch up or down in slot until the switch contacts the activator (Figure 16). You should hear the switch click when it activates.
- 13) Move Gate Open/Close Switch down to close gate.
- 14) Move Gate Manual/Auto Switch to Auto. Gate should now activate and open to the setting you just made.
- 15) Repeat steps 10) through 14) as necessary to achieve desired gate setting.

MS-4 Operation

Set MS-4 Sonic Switch

The MS-4 sonic switch:

1. Provides automatic control of gate position when gate auto/manual switch is in auto position only.
2. Provides automatic operation of paver hopper indicator lights when signal switch is in center position only.

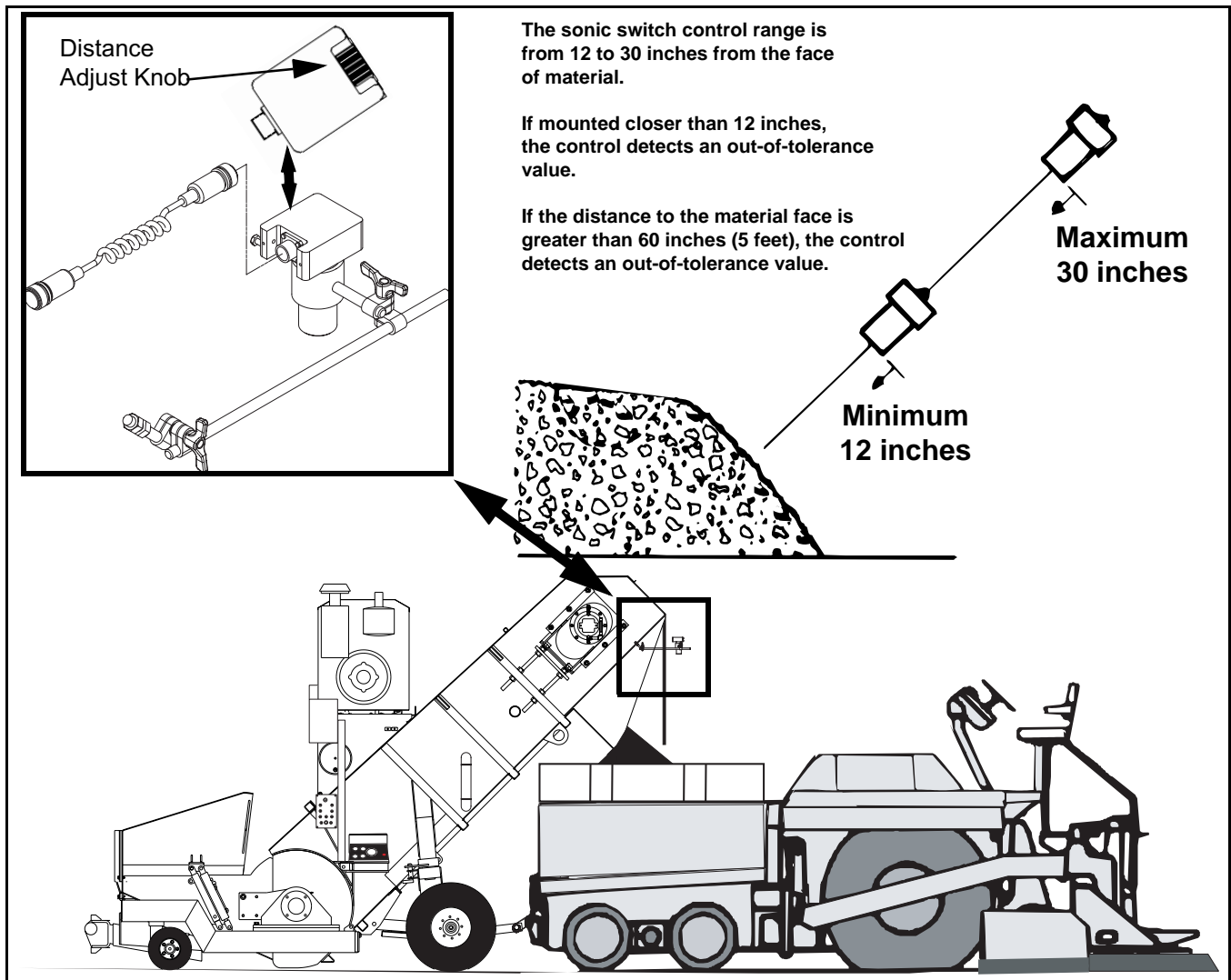

Figure 17 MS-4 Sonic Switch Adjustment

- 1) Position switch so it is between the minimum and maximum distances described above.
- 2) Next set distance adjust knob on switch to maintain paver hopper level at desired height.



MS-4 Operation

Operating the MS-4

Once the machine is set up on the job, follow these procedures to start operation of the MS-4 with your paver. Refer to (Figure 12) for controls.

- 1) Secure all machine-to-paver attachment points.
- 2) Inspect fluid levels.
- 3) Inspect conveyor for obstructions. Clear any obstructions before proceeding.
- 4) Set Conveyor Speed Dial to Min.
- 5) Set Conveyor Switch to Off.
- 6) With Engine Start/Stop/Run Switch in Run position, jog Throttle Control Switch to Down to make sure engine throttle will be at idle.
- 7) Advise personnel of start up.
- 8) Move Permissive Start Switch to Engage position and hold while moving Engine Start/Stop/Run Switch to Start position until engine starts.

Notice - If engine does not start in 30 seconds, allow starter to cool before trying again.
- 9) Once engine starts, release Start/Stop/Run Switch and continue to hold Permissive Start Switch for approximately 15 seconds or until oil pressure is established.
- 10) Verify correct engine oil pressure and other engine gauge readings. (Consult engine owner's manual)
- 11) Move Throttle Control Switch to set engine speed at 2000 RPM.
- 12) Move Frame Switch up or down and set frame height to allow adequate ground clearance without being too high.
- 13) Move Gate Manual/Auto Switch to Auto. This will cause the gate to open to the previously adjusted setting.
- 14) Move Conveyor Switch to On.
- 15) Set Conveyor Speed Dial to desired speed.
Min. - Slowest speed.
Max. - Fastest speed.
- 16) Move Push Beam Extend/Retract Switch to allow the push beam rollers to make contact with transport truck tires.
- 17) If equipped with the optional truck hitch, use the Truck Hook In/Out Switch to engage or disengage hitch rollers.
- 18) Move Push Beam Float/Hold Switch to either Float or Hold position depending which mode of operating you wish. See the following for more detail regarding these modes.
- 19) MS-4 is now ready to receive and transfer material.

Notice - To prevent excessive material flow, transport trucks must have end gates chained open at 12 to 18 inches before releasing gates.

MS-4 Operation

Push Beam in Float Mode

Using the push beam with the switch in Float mode causes the Float/Hold valve to be energized allowing return oil from the piston side of the cylinders to flow through the valve, passing through an adjustable orifice and then back to tank (Figure 18). By adjusting this orifice, you may vary the amount of cushion the push beam will give.

Push Beam Hold Mode

Using the push beam with the switch in Hold mode de-energizes the Float/Hold valve and blocks return oil from the piston side of the cylinders. This effectively “holds” the cylinders in position. The cylinders are cushioned by the accumulators which absorb any shock loads caused by trucks backing into the push beam (Figure 18).

Cleaning Machine

At the end of working day, shift, or when machine is stored, all material should be removed from the hopper and it should be sprayed-down and cleaned.

- 1) Shut off all machine functions.
- 2) Shut off engine.
- 3) Using spraydown system, spray elevator flights, chains, sprockets, and liners.
- 4) Restart engine.
- 5) Advance elevator to un-sprayed components, then repeat above steps as necessary until all components have been covered.

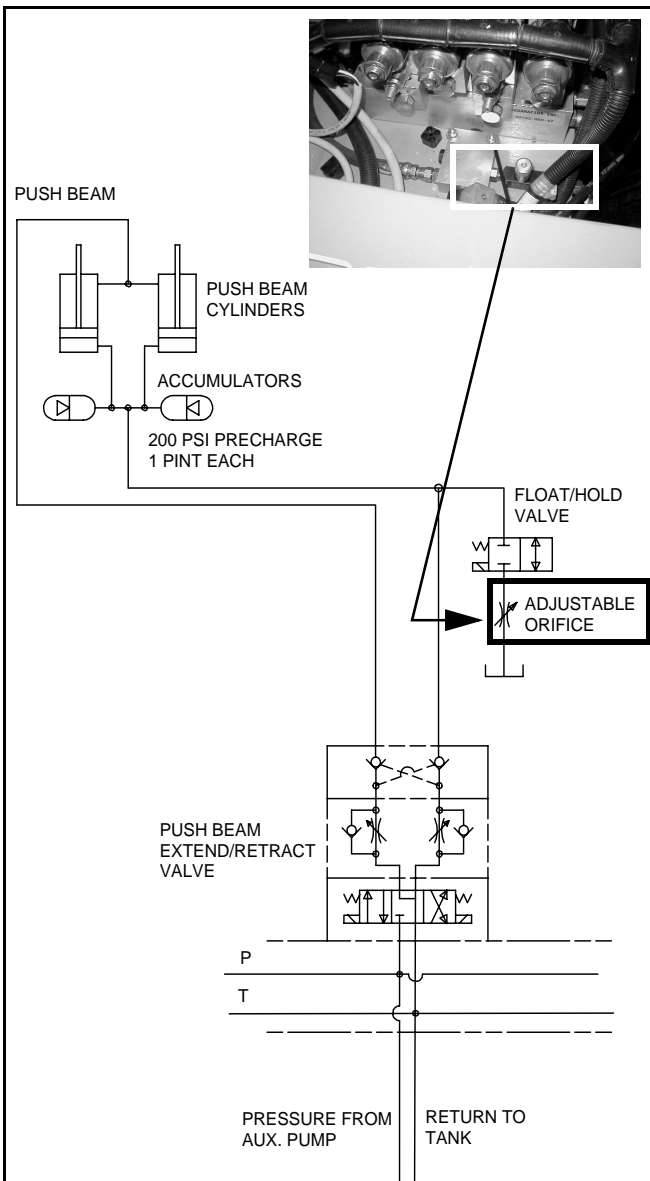

Figure 18 Push Beam Hydraulic Schematic

Electrical

6 - Schematics

Electrical

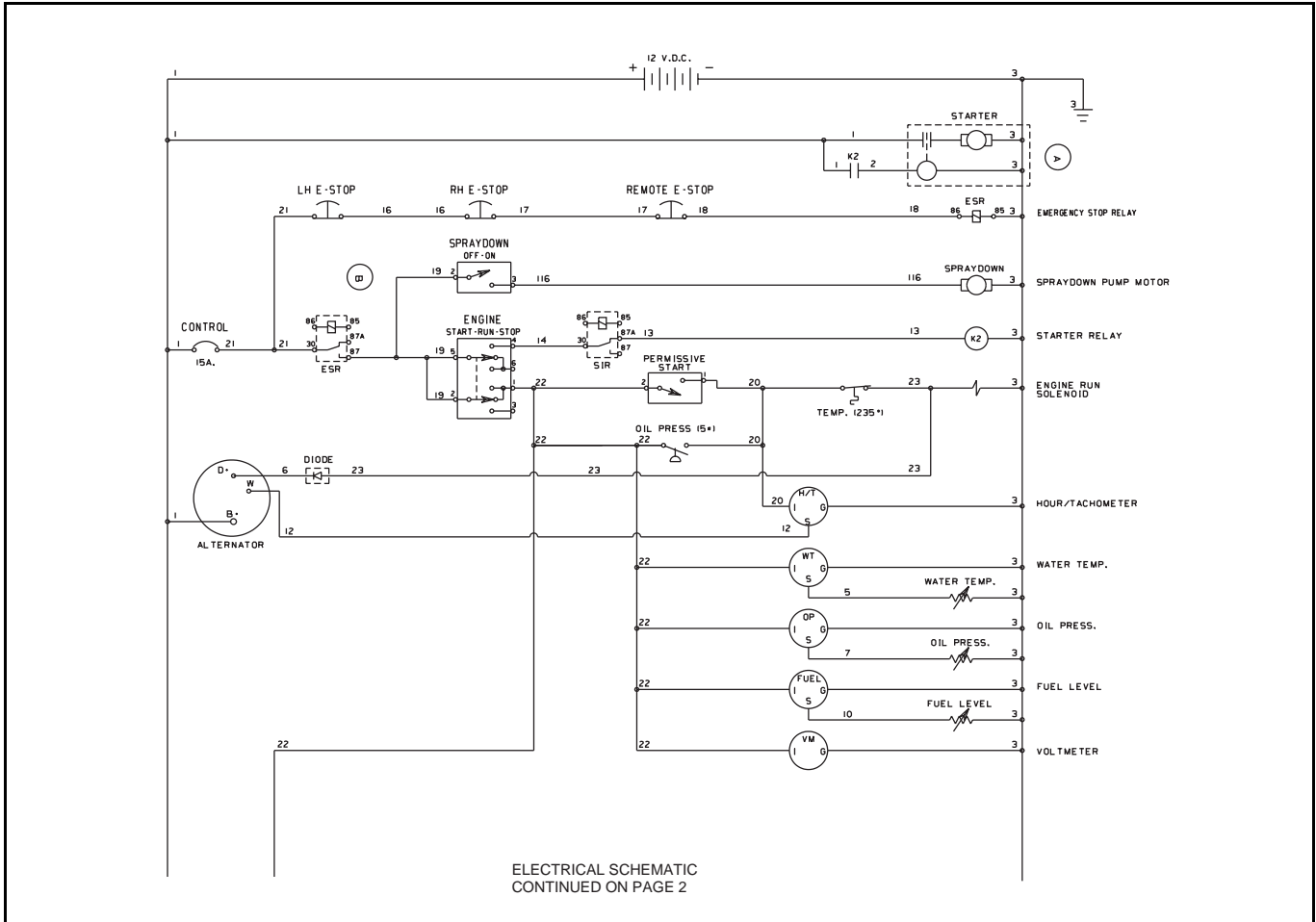

Figure 19 MS-4 Electrical Schematic (from 4495-006) Page - 1

Electrical

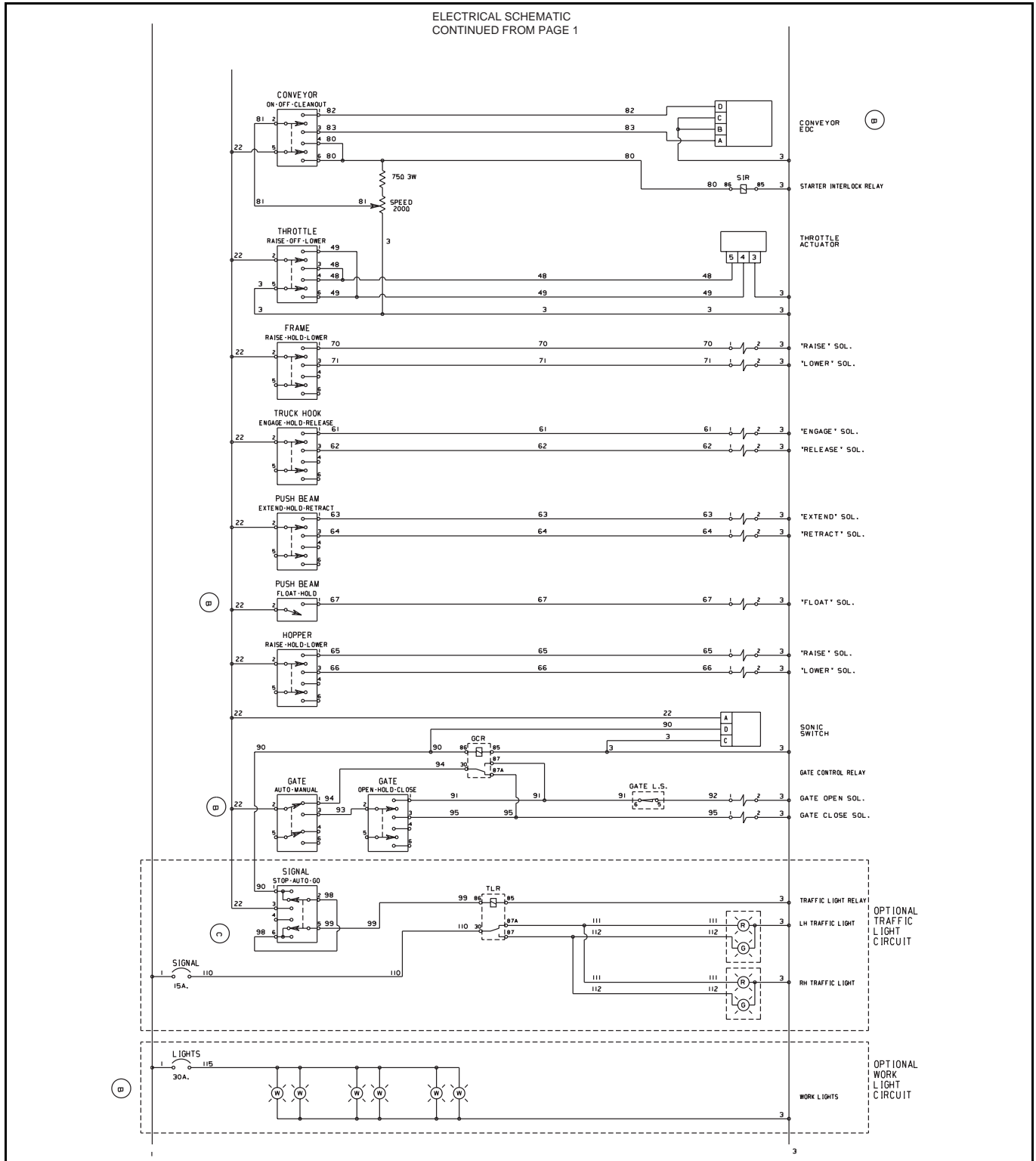

Figure 20 MS-4 Electrical Schematic (from 4495-006) Page - 2

Hydraulic

Hydraulic

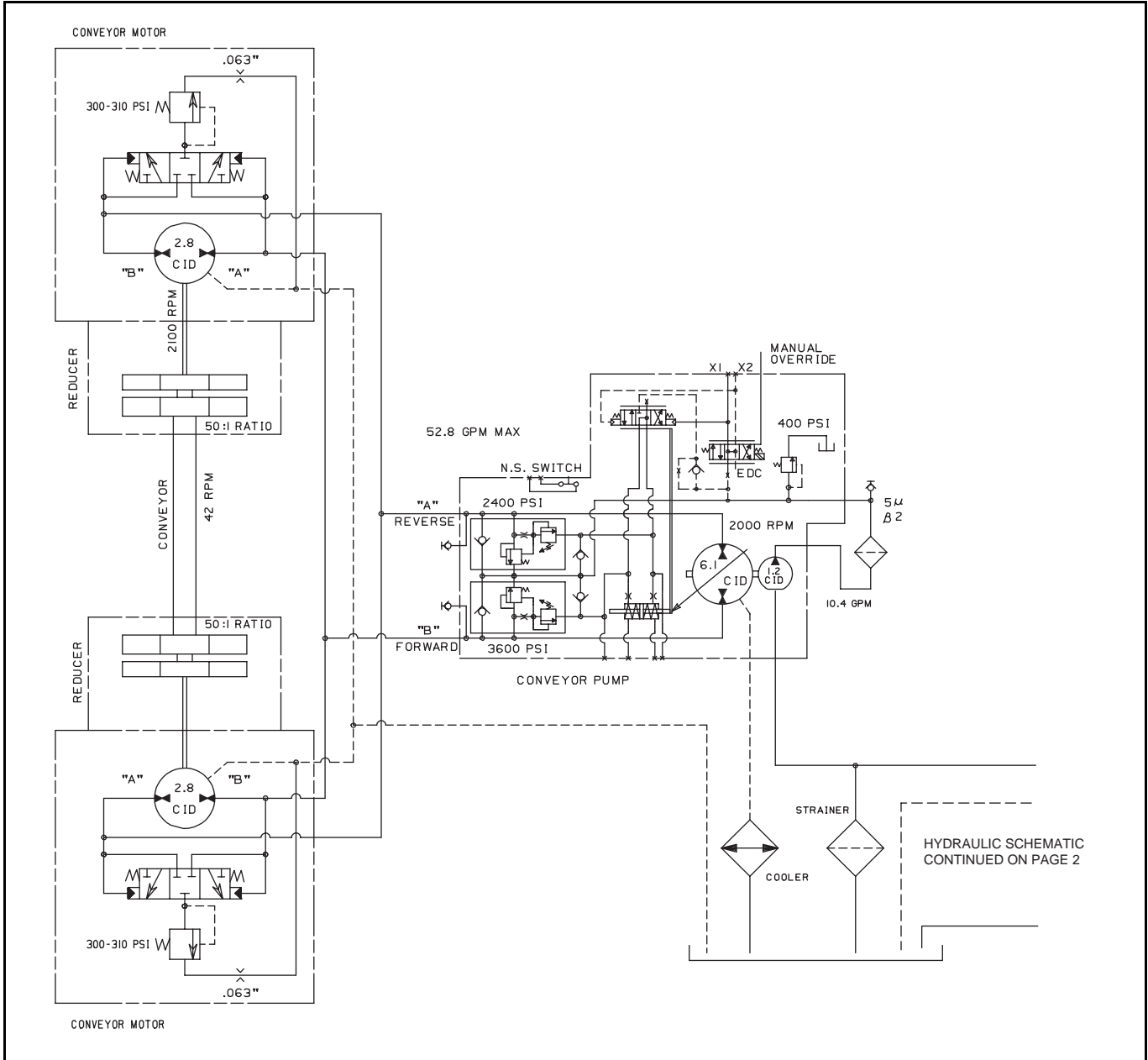

Figure 21 MS-4 Hydraulic Schematic (from 4495-006) Page - 1

Hydraulic

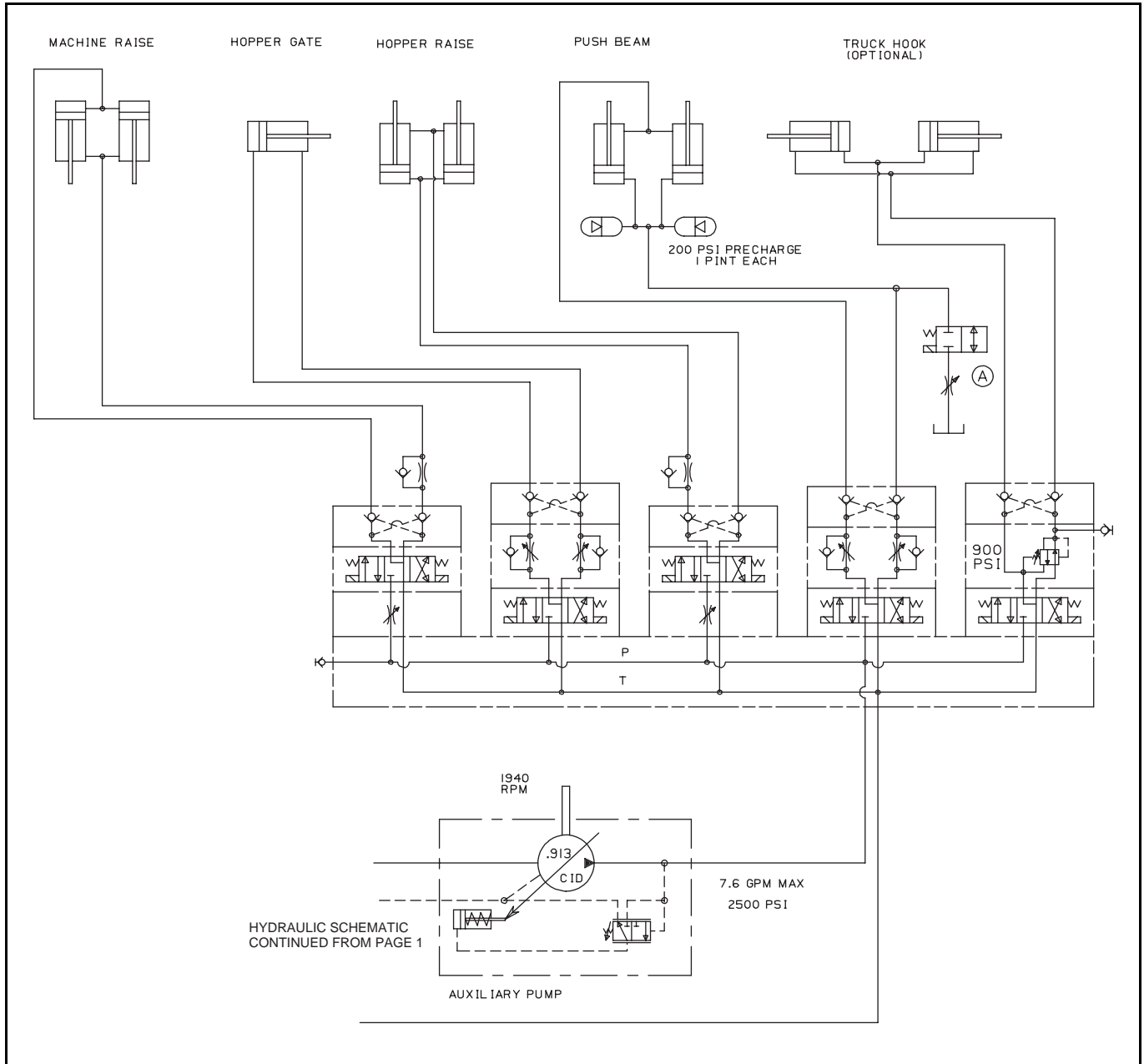

Figure 22 MS-4 Hydraulic Schematic (from 4495-006) Page - 2

Torque Charts

7 - Torque Specifications

Torque Charts

The following pages contain charts for use as guides when tightening bolts and nuts. These specifications should be followed unless specific torques are given elsewhere in this manual.

Standard Torque Chart

Table - 1 is a list of recommended torque values for standard bolts. Use this torque chart to avoid overstressing standard nuts and bolts used on Cedarapids equipment. These specifications should be followed unless specific torques are given. Cedarapids uses Grades 2, 5, and 8. The maximum torque values are based on 75% of the specified minimum proof strength of the bolt steel in order to provide a safety factor. The term “lube” applies to cadmium plating and/or application of thread lubricants. Hardened washers should always be used, regardless of whether standard nuts or lock nuts are employed.

Metric Torque Chart

Table - 2 is a list of torque values recommended for metric bolts. The maximum torque values are based on 75% of the specified minimum proof strength. The term “lube” includes the application of thread lubricants, cadmium plating and the use of hardened washers regardless of whether standard or lock nuts are used.



Torque Charts

dia. (inches)	pitch (thread/in.)	S.A.E Grade 2			S.A.E Grade 5			S.A.E Grade 8		
		Torque (ft-lbs)		Clamp Load (lbs)	Torque (ft-lbs)		Clamp Load (lbs)	Torque (ft-lbs)		Clamp Load (lbs)
		Dry	Lube		Dry	Lube		Dry	Lube	
1/4	20	5	4	1310	8	6	2020	12	9	2860
1/4	28	6	5	1500	10	7	2320	14	11	3270
5/16	18	11	9	2160	17	13	3340	25	19	4710
5/16	24	12	10	2390	19	15	3690	27	21	5220
3/8	16	20	15	3190	31	24	4940	44	34	6970
3/8	24	23	17	3620	35	27	5590	49	38	7900
7/16	14	32	25	4380	49	38	6770	70	54	9560
7/16	20	36	27	4890	55	42	7560	78	60	10680
1/2	13	49	38	5850	75	58	9040	106	82	12770
1/2	20	55	42	6590	85	65	10190	120	92	14390
9/16	12	70	54	7500	109	84	11600	150	115	16380
9/16	18	79	60	8370	121	93	12940	170	130	18270
5/8	11	97	75	9320	150	115	14400	210	160	20340
5/8	18	110	85	10560	170	130	16320	240	180	23040
3/4	10	170	130	13770	265	200	21290	375	285	30060
3/4	16	190	145	15380	295	225	23770	415	320	33570
7/8	9	165	125	11430	425	330	29450	605	465	41580
7/8	14	180	140	12590	470	360	32440	665	510	45810
1	8	245	190	14990	640	495	38630	905	695	54540
1	14	270	210	16400	700	540	42260	990	765	59670
1-1/8	7	350	270	18880	790	610	42340	1285	990	68670
1-1/8	12	395	305	21180	890	685	47500	1440	1110	77040
1-1/4	7	495	380	23980	1120	860	53770	1815	1395	87210
1-1/4	12	550	425	26550	1240	950	59550	2010	1545	96570
1-3/8	6	655	500	28580	1465	1130	64100	2380	1830	103950
1-3/8	12	745	570	32540	1670	1285	72980	2710	2085	118350
1-1/2	6	865	665	34770	1945	1495	77970	3160	2430	126450
1-1/2	12	975	750	39120	2190	1685	87740	3555	2735	142290
1-3/4	5	1370	1055	47020	2285	1755	78370	4985	3835	170990
2	4.5	2060	1585	61870	3435	2640	103120	7500	5765	225000
2-1/4	4.5	3015	2320	80430	5025	3865	134060	10960	8435	292500
2-1/2	4	4125	3170	99000	6875	5285	165000	15000	11530	360000
2-3/4	4	5590	4300	122010	9320	7165	203360	17790	13680	388230
3	4	7385	5680	147750	12310	9470	246260	23500	18080	470130

Table - 1 Torque Values for Standard Hardware



Torque Charts

		Property Class = 8.8				Property Class = 10.9				Property Class = 12.9			
dia (mm)	pitch (mm)	Dry		Lube		Dry		Lube		Dry		Lube	
		(ft-lbs)	N-M	(ft-lbs)	N-M	(ft-lbs)	N-M	(ft-lbs)	N-M	(ft-lbs)	N-M	(ft-lbs)	N-M
10	1.5	37	50	29	39	53	72	41	56	62	84	48	65
10	1.25	39	53	30	41	56	76	43	58	66	89	51	69
12	1.75	65	88	50	68	93	126	71	96	109	148	83	113
12	1.25	71	96	55	75	101	137	78	106	119	161	91	123
14	2	104	141	80	108	148	201	114	155	173	235	133	180
14	1.5	112	152	86	117	160	217	123	167	187	254	144	195
16	2	161	218	124	168	230	312	177	240	269	365	207	280
16	1.5	172	233	132	179	246	334	189	256	287	389	221	300
18	2.50	230	312	177	240	318	431	245	332	372	504	286	388
18	1.5	258	350	199	270	357	484	275	348	418	567	321	435
20	2.5	325	441	250	339	450	610	346	469	525	712	404	548
20	1.5	360	488	277	376	499	677	384	521	583	791	448	607
22	2.5	443	601	341	462	613	831	471	639	716	971	551	747
22	1.5	486	659	374	507	673	913	518	702	786	1066	605	820
24	3	562	762	432	586	777	1054	598	811	908	1231	698	946
24	2	612	830	471	639	847	1149	652	884	990	1342	762	1033
27	3	823	1116	633	858	1139	1544	876	1188	1331	1805	1024	1389
27	2	889	1205	683	926	1229	1667	945	1281	1436	1947	1105	1498

Table - 2 Torque Values for Metric Hardware



Torque Charts