

ROSCO

A LeeBoy Company

RA-2000 PATCHER

ROSCO MANUAL PART NO. 38022-02

EFFECTIVE SERIAL NO. 37360 and higher

REVISED 5/31/01

OPERATION, MAINTENANCE, SERVICE AND PARTS CATALOG

NOTE: It is the responsibility of the customer or user's management to train, educate and supervise the employee in the proper operation and maintenance of this equipment.

688 North Highway 16
Denver, North Carolina
www.LeeBoy.com
Phone: 704-966-3300

Table of Contents

Introduction ----- 0.2 - 0.3

Serial Number Location ----- 0.3

Warranty ----- 0.4 - 0.5

Specifications ----- 0.6 - 0.8

Safety Section ----- 1.1 - 1.12

 Safety Symbols and Signal Words ----- 1.2

 Introduction ----- 1.3

 General Safety ----- 1.4

 Operating Safety ----- 1.5 - 1.7

 Maintenance Safety ----- 1.7 - 1.8

 Hot Material Safety ----- 1.8

 Electric Heater Safety ----- 1.8

 Fire and Explosion Prevention ----- 1.8 - 1.9

 Battery Safety ----- 1.9

 Tire Safety ----- 1.9

 Refueling Safety ----- 1.10

 Transport Safety ----- 1.10

 Storage Safety ----- 1.10

 Safety Decals ----- 1.10

 Safety Decal Installation ----- 1.11

 Sign Off Form ----- 1.12

Safety Decal Location ----- 2.1 - 2.6

Material Section ----- 3.1 - 3.8

 Aggregate Selection ----- 3.2

 Liquid Asphalt Selection ----- 3.3 - 3.4

 Liquid Asphalt Storage and Handling ----- 3.5 - 3.7

Table of Contents (cont'd)

<i>Operation Section</i>	4.1 - 4.15
Theory of Operation	4.2
Truck and Hitch Preparation	4.3 - 4.4
Pre-start and Asphalt Heating	4.5 - 4.8
System Controls	4.9 - 4.10
Patching Instructions	4.11 - 4.14
 <i>Maintenance Section</i>	 5.1 - 5.17
General Introduction	5.2
Engine Maintenance	5.2 - 5.6
Electrical Maintenance	5.7
Patching System Maintenance	5.8 - 5.10
Chassis and Running Gear Maintenance	5.11 - 5.12
Storage	5.13 - 5.15
Lubrication	5.15
Preventive Maintenance Chart	5.16
Bolt Torque Chart	5.17
 <i>Trouble Shooting Section</i>	 6.1 - 6.6
 <i>Parts Catalog</i>	 Section 7

INTRODUCTION

Introduction ----- 0.2 - 0.3

Warranty ----- 0.4 - 0.5

Specifications ----- 0.6 - 0.8

INTRODUCTION

This manual has been compiled to assist the owner and/or operator with the correct operation, safe handling, troubleshooting and routine preventive maintenance procedures for the Model RA-2000 Patcher as manufactured by ROSCO /LeeBoy 688 North Highway 16, Denver , North Carolina, USA A parts catalog is also included in this manual to allow for the accurate ordering of repair parts from authorized Rosco dealers/distributors.

This manual is not intended as an asphalt patching training manual, as it does not contain the vast amount of knowledge needed, which is a prerequisite, to becoming a qualified operator or service person for this machine. Some of the knowledge necessary to be a qualified operator and/or service person includes, but is not limited to:

- * A knowledge and actual experience in the handling of various asphalt products.
- * An understanding and practical experience of job site safety.
- * Experience and knowledge of heavy construction equipment operation and maintenance.
- * Knowledge and practical experience in the variety of situations involved with mobile job site traffic control. This must include a familiarity with federal, state and local laws.

If you do not have this level of both knowledge and practical experience, you are not qualified to operate or maintain the RA-2000. Request this training and job experience from your supervisor. It is dangerous to yourself and others on the job site to operate the Patcher without this training and experience.

THIS MANUAL HAS BEEN ORGANIZED INTO EIGHT (8) MAJOR SECTIONS:

- | | |
|----------------------------|---------------------|
| 0. INTRODUCTION & WARRANTY | 4. OPERATION |
| 1. SAFETY | 5. MAINTENANCE |
| 2. SAFETY DECALS | 6. TROUBLE SHOOTING |
| 3. MATERIAL CONSIDERATIONS | 7. PARTS CATALOG |

A general contents page is located at the beginning of this manual as a quick reference to the these sections and their major sub-sections. In order to receive the performance and efficiency that has been designed into the RA-2000 Patcher, it is very important that you:

- A. Read this manual thoroughly before operating or servicing the Patcher.
- B. Keep this manual in a convenient place for ready reference.
- C. Do not attempt repairs or adjustments you do not understand. If you require additional information or service, contact your authorized ROSCO dealer/distributor.

Throughout this manual references are made to the **left** side and **right** side of the Patcher. These terms are used as the Patcher is viewed from the rear of the machine.

SERIAL NUMBER - Record the serial number of this equipment. The serial number plate is located on the left front frame rail of the Patcher (see Fig. 0-A), and a space has been provided on the following page to record it. Use the serial number in all correspondence with your ROSCO dealer/distributor and when ordering parts.



ROSCO MANUFACTURING COMPANY reserves the right to make design or specification changes without prior notification or to make any other improvements without incurring obligations to add them to any machine in existence.

ROSCO MANUFACTURING COMPANY is continuously improving its products. The technical information found in this manual was correct at the time it was approved for publication. However, if you find differences between your Patcher and the information contained in this manual, please contact your local authorized ROSCO dealer/distributor.

SERIAL NUMBER LOCATION

Always give your dealer the serial number of your ROSCO RA-2000 Patcher when ordering parts or when requesting service.

The serial number plate is located on the frame as indicated by the arrow in the illustration below. Please mark the number in the space provided on this page for easy reference.

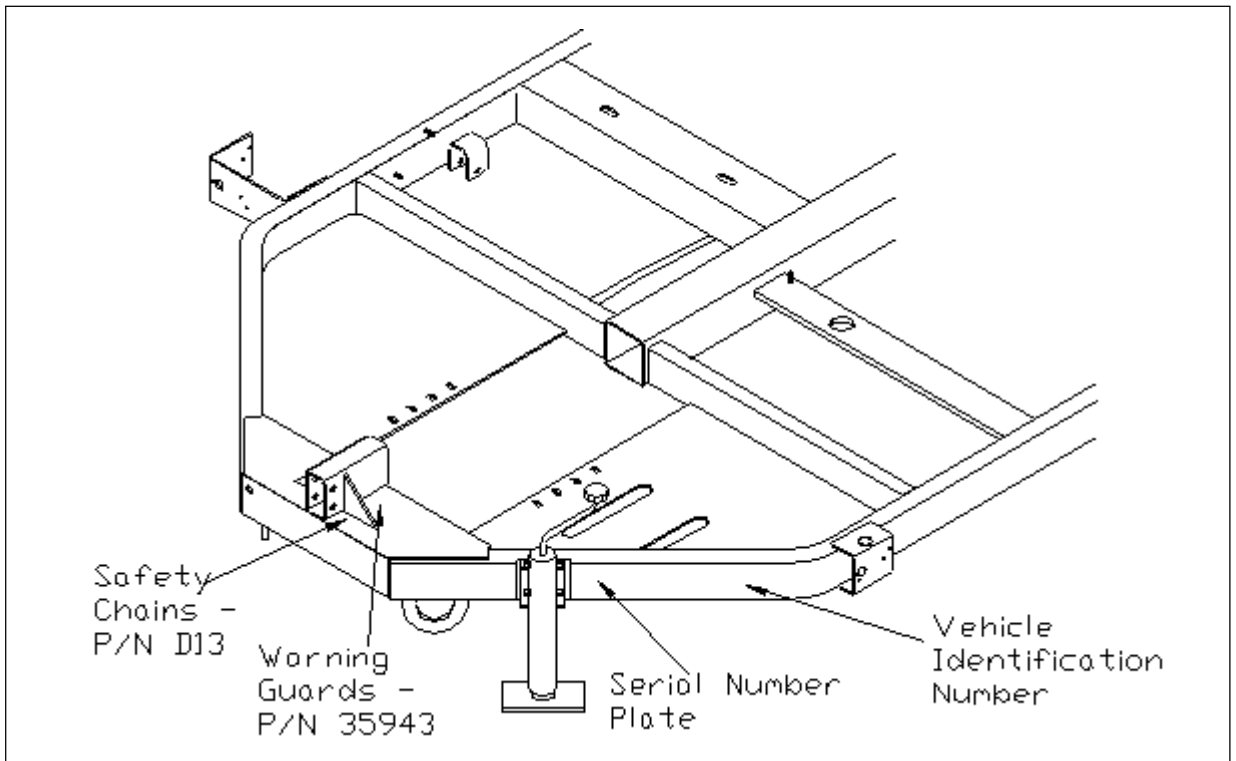

Figure 0-A

Model _____

Serial Number _____

Production Year _____

LIMITED WARRANTY POLICY

A. WARRANTY

1. If a defect in material or workmanship is found and the authorized Dealer is notified during the warranty period, ROSCO will repair or replace any part or component of the unit or part that fails to conform to the warranty during the warranty period.
2. The warranty will begin upon the completion of the warranty form by the initial customer and will expire after twelve (12) months have passed. The Warranty Card must be filled out within ten (10) days of delivery of the unit.
3. Engines and truck chassis are warranted by their manufacturers and may have warranty coverage that differs from that of ROSCO.
4. Replacement parts furnished by ROSCO are covered for the remainder of the warranty period applicable to the unit or component in which such parts are installed.
5. ROSCO has the right to repair any component or part before replacing it with a new part.
6. All new replacement parts purchased by a ROSCO dealer will carry a six (6) month warranty. Remanufactured parts purchased by a ROSCO dealer will carry a ninety (90) day warranty.

B. LIMITATIONS

ROSCO has no obligation under this warranty for:

1. Any defects caused by misuse, misapplication, negligence, accident or failure to maintain or use in accordance with the most current operating instructions.
2. Unauthorized alterations.
3. Defects or failures caused by any replacement parts or attachments not manufactured by or approved by ROSCO.
4. Failure to conduct normal maintenance and operating service, including without limitation, providing lubricants, coolant, fuel, tune-ups, inspections or adjustments.
5. Unreasonable delay, as established by ROSCO, in making the applicable units or parts available upon notification of a service notice ordered by ROSCO.
6. The warranty responsibility on all engines and/or truck chassis rests with the respective manufacturer.
7. ROSCO may have support agreements with some engine and/or truck chassis manufacturers for warranty and parts support.

LIMITED WARRANTY POLICY

C. ITEMS NOT COVERED

ROSCO is not responsible for the following:

1. Charges for travel time, mileage or overtime.
2. Charges related to transporting the product to and from the place at which warranty work is performed.
3. Airfreight charges related to transporting repair parts to the place at which warranty work is performed.
4. All used units or used parts of any kind.
5. Repairs made necessary by normal wear and tear or brought about by abuse or lack of maintenance of the equipment, except for premature failures.
6. Attachments not manufactured or installed by ROSCO.
7. Liability for incidental or consequential damages of any type, including, but not limited to lost profits or expenses of acquiring replacement equipment.
8. Miscellaneous charges.

D. OTHER WARRANTIES

THE FOREGOING WARRANTY IS EXCLUSIVE AND IN LIEU OF ALL OTHER EXPRESSED, STATUTORY AND IMPLIED WARRANTIES APPLICABLE TO UNITS, ENGINES OR PARTS, WITHOUT LIMITATION, AND ALL IMPLIED WARRANTIES OF MERCHANTABILITY OR FITNESS FOR ANY PARTICULAR USE OR PURPOSE. IN NO EVENT, WHETHER AS A RESULT OF BREACH OF CONTRACT OR WARRANTY, OR ALLEGED NEGLIGENCE OR LIABILITY WITHOUT FAULT, SHALL ROSCO BE LIABLE FOR SPECIAL, INCIDENTAL OR CONSEQUENTIAL DAMAGES, INCLUDING WITHOUT LIMITATION, LOSS OF PROFIT OR REVENUE, COST OF CAPITAL, COST OF SUBSTITUTED EQUIPMENT, FACILITIES OR SERVICES, DOWN TIME COSTS, LABOR COSTS OR CLAIMS OF CUSTOMERS, PURCHASERS OR LESSEES FOR SUCH DAMAGES.

SPECIFICATIONS

ROSCO/LeeBoy reserves the right to make design or specification changes without prior notifications or to make any other improvements without incurring obligations to add them to any machine in existence.

ROSCO / LeeBoy is continuously improving its products. The information found in this manual was correct at the time it was approved for publication.

DIMENSIONS:

Length:
Overall ----- 188 inches (478 cm)
Width:
Travel ----- 96 inches (244 cm)
Height:
Overall ----- 84 inches (213 cm)

WEIGHT:

Shipping ----- 5900 lbs (2676 kg)
Operating ----- 8300 lbs (3765 kg)

CHASSIS:

Frame ----- All Welded Structural Tube Steel
Fenders ----- Removable
Hitch ----- Adjustable Pintle Eye
Safety Chains ----- 0.50 inch steel
Jack Capacity ----- 5000 lbs (2268 kg)

THE FOLLOWING ITEMS ARE NOT SUPPLIED BY ROSCO

Axles ----- Tandem, 6000 lbs (2721 kg) each
Suspension ----- Leaf Spring, 3000 lbs (1361 kg) each
Brakes ----- Electric, Four Wheel, Rated at 2600 lbs (1179 kg) each
Brake Actuation ----- Break Away Switch, Tow Vehicle
Tires ----- ST225/75R-15, 6ply, Load Range C
2150 lbs (975 kg) at 50 psi (345 kPa)



SPECIFICATIONS

Engine:

Type ----- 4 Cylinder, Water Cooled Diesel
 Make & Model ----- Cummins 4B3.9
 Displacement ----- 239 cu. inches (3.92 liters)
 Bore ----- 4.02 inches (102 mm)
 Stroke ----- 4.72 inches (120 mm)
 Power @ 2500 RPM ----- 80 hp (59.65 kw)
 Ignition System ----- 12 volt
 Battery ----- 12 volt, 950 CCA rated
 Alternator ----- 63 amp rated
 Air Cleaner ----- Dual Element, Dry Type, with Indicator
 Oil Filter ----- Full Flow
 Oil Capacity ----- 11.5 qts (10.9 liters)
 Idle Speed ----- 1000 rpm
 Fuel Tank Capacity ----- 24 gallon (90.85 liters)
 Cooling System Capacity ----- 18 qts (17 liters)

Instrumentation:

Engine ----- Tachometer, Hour Meter, Voltmeter, Water Temperature,
 Oil Pressure
 Compressed Air System ----- Pressure Gauge
 Emulsion System ----- Temperature Gauge, Contents Gauge
 Flush System ----- Contents Gauge

Compressed Air System:

Min. Delivery ----- 8.5 cfm (.24 m³/M)
 Reservoir ----- 1200 inch³ (19668 cm³)

Air System:

Make ----- Roots
 Displacement ----- .395 cu. ft./rev (11.18 liters/rev)
 Max Speed ----- 2350 rpm
 Max Pressure Rise ----- 12 psi (82.74 kPa)
 Air Cleaner ----- Dry Type, Replaceable Element

Aggregate System:

Feed System ----- Gravity
 Delivery System ----- Jet Feed (Venturi)
 Aggregate Feed Hopper ----- Slide Gate/One Moving Part
 Control ----- On/Off Switch on Boom

SPECIFICATIONS

Emulsion System:

Nominal Tank Capacity ----- 300 gal (1135 liters)
Tank Insulation ----- Min. 3 inches (7.62 cm) Styrofoam
Min R-15 Rating
Tank Skin ----- 16 gauge Steel
Fill Opening ----- 12 inch (30.5 cm) opening
Heating Elements ----- Two 1125 watt @ 120v
(two 2000 watt @ 240v on European models)
Temperature Control ----- 110° F to 180° F (43° C to 82° C)
Tank Drain ----- 2 inch (5.08 cm)

Boom Assembly:

Boom Type ----- 3 Piece Articulated
Extended Radius ----- 17 ft (5.185 m)
Boom Suspension ----- Adjustable
Nozzle Height Control ----- 0 to 5 ft (0 to 1.25 m)

Flush System:

Solvent Type ----- Biodegradable Citrus Solvent or
other approved types
Solvent Tank Capacity ----- 9.5 gal (36 liters)
Reclaim Tank Capacity ----- 5 gal (18.93 liters)
Solvent Pump ----- Electric 12 volt, 3 GPM, 145 psi;
(11.36 l/M, 999.75kPa)

Operator Controls:

Emulsion/Flush ----- Lever on Boom
Electric Controls ----- Engine Throttle, Aggregate On/Off,
Flush Activate, Signal Horn
Manual Controls ----- 3-Way Emulsion Flow Valve

Optional Equipment:

Crack Filling Attachment with Hand Gun Assembly
Fill Strainer
Ball Hitch
Arrow Board.

SAFETY SECTION

<i>Safety Symbols and Signal Words</i>	1.2
<i>Introduction</i>	1.3
<i>General Safety</i>	1.4
<i>RA-2000 Operators</i>	1.5
<i>Operator Qualifications</i>	1.5
<i>Conduct of Operators</i>	1.5 - 1.6
<i>Operating Safety</i>	1.6 - 1.7
<i>Maintenance Safety</i>	1.7 - 1.8
<i>Hot Material Safety</i>	1.8
<i>Electric Heater Safety</i>	1.8
<i>Fire and Explosion Prevention</i>	1.8 - 1.9
<i>Battery Safety</i>	1.9
<i>Tire Safety</i>	1.9
<i>Refueling Safety</i>	1.10
<i>Transport Safety</i>	1.10
<i>Storage Safety</i>	1.10
<i>Safety Decals</i>	1.10
<i>Safety Decal Installation</i>	1.11
<i>Sign-off Form</i>	1.12

SAFETY

Safety Alert Symbol

This Safety Alert symbol means
**ATTENTION! BECOME ALERT! YOUR
SAFETY IS INVOLVED!**



The Safety Alert symbol identifies important safety messages on the ROSCO RA-2000 Patcher and in this manual. When you see this symbol, be alert to the possibility of personal injury or death. Follow the instructions in the safety message.

Why is SAFETY important to you?

- 3 Big Reasons:**
- | **Accidents Disable and Kill**
 - | **Accidents Cost**
 - | **Accidents Can Be Avoided**

Signal Words

Note the use of the signal words **DANGER**, **WARNING** and **CAUTION** with the safety messages. The appropriate signal word for each message has been selected using the following guidelines:

- | | |
|----------------|---|
| DANGER | An immediate and specific hazard which WILL result in severe injury or death if the proper precautions are not taken. |
| WARNING | A specific hazard or unsafe practice which COULD result in severe injury or death if proper precautions are not taken. |
| CAUTION | Unsafe practices which COULD result in personal injury if proper practices are not taken, or as a reminder of good safety practices. |

Equipment Damage Symbol



Throughout this manual, whenever you see this "broken bolt" symbol, it means:

ATTENTION - Equipment on the machine could be damaged through improper performance of an operation, maintenance or repair procedure.

SAFETY

YOU are responsible for the SAFE operation and maintenance of your ROSCO RA-2000 Patcher. **YOU** must ensure that you and anyone else who is going to operate, maintain or work around the patcher be familiar with the operating and maintenance procedures and related **SAFETY** information contained in this manual. This manual will take you step-by-step through your working day and alert you to good safety practices that should be followed while operating the Patcher.

Bituminous asphalt is a volatile material that must be handled at high temperature. Serious burns can occur from touching the material or machine. Wear protective clothing at all times and keep the machine in good working condition. Fumes from hot emulsions could ignite. **DO NOT** use cutback asphalts. They are highly explosive. Read all instructions and follow them. Emulsified asphalts are used at lower temperatures, but are still hot enough to cause injury.

Remember, **YOU** are the key to safety. Good safety practices not only protect you but also the people around you. Make these practices a working part of your safety program. Be certain that **EVERYONE** operating this equipment is familiar with the recommended operating and maintenance procedures and follows all the safety precautions. Most accidents can be prevented. Do not risk injury or death by ignoring good safety practices.

☞ Patcher owners must give operating instructions to operators or employees before allowing them to operate the machine, and at least annually thereafter.

☞ The most important safety device on this equipment is a SAFE operator. It is the operator's responsibility to read and understand **ALL** safety and operating instructions in the manual and to follow them so that accidents can be avoided.

☞ A person who has not read and understood all operating and safety instructions is not qualified to operate the machine. An untrained operator exposes himself and bystanders to possible serious injury or death.

☞ **DO NOT** modify the equipment in any way. Unauthorized modification may impair function and/or safety and affect the life of the equipment.

☞ ROSCO Manufacturing Company assumes **NO LIABILITY** for accident or injury incurred through the improper use of this equipment.

GENERAL SAFETY



1. Read and understand the operator's manual and all safety signs **before** operating, maintaining, or adjusting this equipment.

2. Have a first-aid kit available and **know how to use it.**



3. Keep a "charged" fire extinguisher within reach when you work in an area where fire may occur. Have the correct type of extinguisher available and **know how to use it:**



Type A: Wood, paper, textile and rubbish

Type B: Flammable liquid

Type C: Electrical equipment

4. Wear appropriate protective gear. This includes but is not limited to **boots, protective glasses, goggles, face shield, heavy gloves, protective coveralls, hearing protection, protective head gear and orange safety vest.**



5. Install and secure all guards before starting.

6. Bituminous asphalt material must be hot to be applied. Protect yourself from touching the machine or asphalt material. Severe burns can occur.

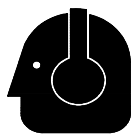

7. Wear appropriate ear protection to protect hearing from excessive noise. Permanent loss of hearing can result from prolonged exposure.

8. Place all controls in neutral, stop engine, set park brake on towing vehicle, remove ignition key and wait for all moving parts to stop before servicing, adjusting or repairing. Death

GENERAL SAFETY (cont.)

or serious injury can result if one becomes entangled in moving parts.

9. Clear the area of people before starting or operating the unit. Death or serious injury can occur from being crushed under moving machinery or being hit by the boom.



10. **DO NOT** hurry! Use recommended hand holds and steps with at least three points of support when getting on and off the Patcher. Keep steps, floor, hand holds and controls clean and free from grease. Face the machine when climbing up and down and **never** jump off or dismount while the machine is in motion. Falls from the machine can cause serious injury.

11. Review safety related items annually with all personnel who will be operating or maintaining the Patcher.

12. Do not run truck engine or Patcher in an enclosed area. Exhaust gases contain carbon monoxide, an odorless and deadly poison.



13. Do not use the Patcher without first providing proper traffic control measures. Injury and property damage can occur when traffic collides with the Patcher.

14. Do not inflate tires beyond the maximum recommended inflation pressure. Death or serious injury can occur from tires exploding due to overinflation.

15. Do not hang additional components from the discharge hose support boom. The hose support boom is not designed to be used as a means for lifting.

RA - 2000 OPERATORS

1. Operation shall be limited to personnel with the following minimum qualifications:
 - Designated persons.
 - Trainees under the direct supervision of a designated person.
 - Maintenance and test personnel in the performance of their duties.
2. No one other than the personnel specified above shall operate the patcher with the exception of persons such as oilers, supervisors and those specified persons authorized by supervisors whose duties require them to do so and then only in the performance of their duties and with the knowledge of the operator or other appointed person.

OPERATOR QUALIFICATIONS

1. Operators shall be required by the employer to pass an operating examination.
2. Operators and operator trainees shall meet the following physical qualifications:
 - Vision of at least 20/30 Snellen in one eye and 20/50 in the other, with or without corrective lenses.
 - Ability to distinguish colors, regardless of position, if color differentiation is required for operation.
 - Adequate hearing, with or without a hearing aid, for the specific operation.
3. Evidence of physical defects or emotional instability which could create a hazard to the operator or others, or which, in the opinion of the examiner, could interfere with the operator's performance, may be sufficient cause for disqualification. In such cases, specialized clinical or medical judgments and tests may be required.
4. Evidence that an operator is subject to seizures or loss of physical control shall be

OPERATOR QUALIFICATIONS

(cont.)

- sufficient reason for disqualification. Specialized medical tests may be required to determine these conditions.
5. Operators and operator trainees should have normal depth perception, field of vision, reaction time, manual dexterity, coordination and no tendencies to dizziness or similar characteristics.
 6. In addition to the above listed requirements, the operator shall:
 - Demonstrate the ability to comprehend and interpret all labels, operator manuals, safety codes and other information pertinent to correct Patcher operation.
 - Possess knowledge of emergency procedures and the ability to implement them.
 - Demonstrate to the employer the ability to operate the specific type of equipment.
 - Be familiar with applicable safety regulations.
 - Understand responsibility for maintenance requirements of the Patcher.
 - Be thoroughly familiar with the Patcher and its control functions.
 - Understand the operating procedures as outlined by the manufacturer.

CONDUCT OF OPERATORS

1. The operator shall not engage in any practice which will divert his/her attention while operating the Patcher.
2. Each operator shall be responsible for those operations under his or her direct control. If there is a concern about safety, the operator shall consult with the supervisor.
3. If a warning signal is being issued by a switch, engine control or component, the operator shall not operate the switch, control or component until the danger has been corrected or acknowledged by the appointed person.

CONDUCT OF OPERATORS (cont.)

4. Before operating the Patcher, the operator shall see that all controls are in the **OFF** or neutral position and that all personnel are in the clear.

5. In accordance with OSHA regulations 1928.51 and 1928.52, operating instructions must be provided initially to operators and employees before allowing them to operate the RA-2000. These should be reviewed annually.

*The most **IMPORTANT** safety device on this equipment is a well trained and safe operator. It is his/her responsibility to read and understand all safety and operating instructions in this manual. A person who has not read and understood all operating and safety instructions is not qualified to operate the patcher. An untrained operator exposes him or herself and bystanders to possible serious injury or death. **All accidents can be avoided!***

DO NOT modify the Patcher in any way. Unauthorized modification may impair function and/or safety and affect the working life of the equipment.

ROSCO Manufacturing Company assumes **NO LIABILITY** for accident or injury incurred through the improper use of this equipment.

OPERATING SAFETY

1. Do not allow riders on the Patcher when transporting. Death or serious injury can occur from riders falling off or under the Patcher while it is in motion.

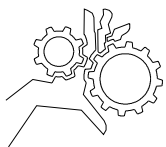

2. Keep hands, feet, hair and clothing away from moving parts. Death or serious injury can occur if one becomes entangled in moving parts.

OPERATING SAFETY (cont.)

3. Never extend the discharge boom into unprotected or uncontrolled lanes of traffic. Death or serious injury can occur when the boom collides with passing traffic.

4. Operate the Patcher only from the operator's control position of the boom. Hot asphalt can cause severe burns and the boom can cause injuries by crushing.

5. Clean reflectors and lights so they are visible before transporting to avoid collisions with other traffic.



6. **DO NOT** smoke around the Patcher. Fuel, emulsion and fumes can explode when exposed to flame or heat.

7. Operate the Patcher only in well ventilated areas. Death can occur from carbon monoxide poisoning.



8. Pressure in asphalt or flush tank **MUST** be released with the pressure relief valve before checking or filling the tank. The cap or lid can come off with explosive force causing injury or death if pressure is not released first.

9. The asphalt tank level is checked by using the level gauge on the tank. If you must open the cap to measure the asphalt, do so **ONLY** after fully releasing all air pressure to prevent the lid from exploding open. Make sure all safety considerations are followed.

10. Always lock boom in place before transporting or servicing. A lowered boom may not be noticed by traffic or pedestrians and can cause injury or death in a collision.

11. Prevent serious injury or death from electrical shock by disconnecting the power

OPERATING SAFETY (cont.)

before adjusting the thermostat or servicing electric heaters.

12. Turn warning lights **ON** when operating the Patcher to warn traffic and prevent collisions.

13. **DO NOT** use cutback asphalts. Violent explosion and fire can result causing death or serious injury.

14. Review safety instructions with all operators annually.

15. The operator is responsible for the work area. Keep all bystanders at least 30 feet away from the work area. The high velocity air, oil and aggregate can cause injury.

MAINTENANCE SAFETY

1. Follow **ALL** operating, maintenance and safety information in this manual.

2. **DO NOT** attempt repairs or maintenance procedures you do not understand. Refer to manuals and experienced repair personnel for help.

3. Clean asphalt and oil accumulations from surfaces that can get hot. Asphalt and oil are flammable. Oil accumulations are slippery and may result in injury from slipping or falling.

4. Support the RA-2000 with blocks or safety stands when changing tires or working beneath it. Serious injury or death can result if the machine falls.

5. Place all controls in neutral, stop engine, set park brake on towing vehicle, remove ignition key and wait for all moving parts to stop before servicing, adjusting, or repairing. Death or serious injury can result if one becomes entangled in moving parts.

MAINTENANCE SAFETY (cont.)

6. Follow good shop practices:

- o Keep service area clean and dry.
- o Be sure electrical outlets and tools are properly grounded.
- o Use adequate light for the job at hand.



7. Make sure all guards are in place and properly secured when maintenance work is completed. Death or serious injury can result if one becomes entangled in moving parts.

8. **DO NOT** wear loose-fitting or frayed clothing when working on or near any of the drive system components. Loose garments can get caught in moving parts, pulling you into the machine and causing serious injury or death.

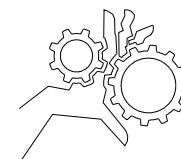

9. Wear protective glasses and other required safety equipment when servicing or repairing the Patcher.



10. Keep hands, feet, hair and clothing away from moving or rotating parts. Death or serious injury can occur if one becomes entangled in moving parts.

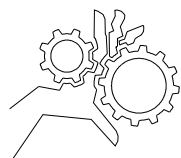

11. Clear the area of bystanders when performing any maintenance, repairs or adjustments. Death or serious injury can result from being crushed under moving machinery, being hit by the boom or by coming in contact with the machine.

12. To avoid burns, allow the machine and material to cool before working on it.

MAINTENANCE SAFETY (cont.)

13. Lock the boom in place before servicing. A lowered boom may not be noticed by traffic or pedestrians and can cause injury or death in a collision.

14. Disconnect the battery ground cable before working on the electrical system. Failure to do so can result in electrical shock or burns.

15. **DO NOT** make repairs on pressurized components, fluid, fuel or mechanics until the pressure has been relieved according to instructions. Lids and covers can open with explosive force causing serious injury or death.

16. Replace all missing, illegible or damaged safety decals or signs. Keep all safety decals and signs clean.

HOT MATERIAL SAFETY

1. Wear protective gear for face, hands, feet and body to prevent burns when working on the Patcher.



2. Keep bystanders away from the machine when operating. Machine components, high velocity air, emulsion or aggregate can cause injury.

3. To prevent injury from burns, allow the machine to cool before performing any repairs or maintenance.

4. If hot asphalt touches the skin, **flush area immediately with cold water**. **DO NOT** apply ice directly to the affected area. **DO NOT** attempt to remove asphalt cement with products containing solvents or ammonia. Natural separation will occur in 48-72 hours. **Get medical attention as soon as possible.**

HOT MATERIAL SAFETY (cont.)

5. Avoid discharge area of boom. Rocks, asphalt emulsion and solvent may spray out suddenly. High velocity air, emulsion and aggregate can cause injury.

ELECTRIC HEATER SAFETY

1. Electric heater equipment must not be operated while the vehicle is being loaded or in transit.

2. Do not exceed asphalt flash temperature. Hot fumes can explode causing severe burns.

3. Stay away from electric heaters while heating material in tank. Keep others away from machine when operating electric heaters. Injury or death can result from electrical shock. Follow electric heater operating instructions.

4. Disconnect the power **before** servicing or performing maintenance on electrical components. Severe injury or death could result. Always use an electrical outlet with ground fault circuit interrupter (GFCI) protection.

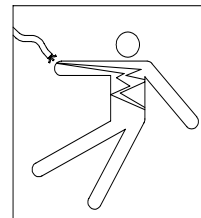

FIRE and EXPLOSION PREVENTION

1. Keep the machine and asphalt material away from sparks, incandescent material, and open flames. Hot bituminous asphalt and its fumes are flammable and can ignite or explode causing serious injury or death.



2. **DO NOT** use cutback asphalts. Violent explosion and fire can result, causing death or serious injury.



FIRE and EXPLOSION PREVENTION (cont.)



3. **DO NOT** mix grades of asphalt material. Hot asphalt can vaporize material with lower flash point temperature and cause an explosion.

4. Pressure in asphalt or flush tanks **MUST** be released with vent valve before checking or filling the tank. Lids or covers can open with explosive force causing serious injury or death.

5. **DO NOT** smoke around the Patcher. Fuel, emulsion and fumes can explode when exposed to flame or heat.



BATTERY SAFETY

1. Keep all sparks and flames away from batteries. Fumes from the battery's electrolyte solution are extremely explosive. Acid propelled by an explosion can cause blindness if it comes in contact with eyes.



2. Avoid contact with battery electrolyte solution. Wash off any spilled electrolyte **immediately** to avoid injury from chemical burns.

3. **Always** wear safety glasses when working near batteries to prevent acid from coming in contact with eyes and causing blindness.

4. To avoid spilling electrolyte solution and prevent chemical burns, **DO NOT** tip batteries more than 45 degrees.

5. To avoid injury from a spark or short circuit, disconnect battery ground cable **before** servicing any part of the electrical system. Failure to do so can result in electrical shock or burns.

TIRE SAFETY



1. Failure to follow proper procedures when mounting a tire on a wheel or rim can produce an explosion which may result in serious injury or death.

2. Do not attempt to mount a tire unless you have the proper equipment and experience to do so.

3. Have a qualified tire dealer or service technician perform required tire maintenance.

4. When inflating tires, use a self-attaching inflation chuck with remote shut off and stand away from the tire.

5. **DO NOT** inflate the tire beyond the tire manufacturer's recommended inflation pressure. Overinflation can cause the tire to explode resulting in serious injury or death.



6. **DO NOT** operate the Patcher with loose wheels or rims. Check wheel nuts periodically for proper tightening torque.

7. **DO NOT** hammer on rims with steel hammers. Use rubber, lead, plastic or brass faced mallets if necessary.

8. Block the tire and wheel on the opposite side of the vehicle before you place a jack in position.

9. Place hardwood blocks under the jack regardless of how hard or soft the ground is. **Always** support the vehicle with blocks, preferably with jack stands, in case the jack slips.

REFUELING SAFETY



1. Handle fuel with care. It is highly flammable and can cause serious injury or death if it explodes or ignites. Be sure to clean up spilled fuel before restarting the engine.

2. **DO NOT** smoke when refueling. Open flame or sparks can cause an explosion resulting in serious injury or death.



3. Fill the fuel tank outdoors to reduce the chance of fumes accumulating and causing a fire or explosion.
4. Prevent fires by keeping the machine clean of accumulated grease and debris.
5. **DO NOT** allow fuel to spill on hot components. Maintain control of the fuel filler nozzle when filling the tank.
6. To reduce the risk of fuel expanding and spilling from the tank, **DO NOT** overfill the fuel tank.
7. Tighten the fuel tank cap securely. If the fuel cap is lost, replace it only with the original manufacturer's approved cap. Use of a non-approved cap without proper venting may result in pressurization of the tank.

TRANSPORT SAFETY

1. Make sure you are in compliance with all local regulations regarding transporting equipment on public roads and highways. **DO NOT DRINK AND DRIVE.**
2. Make sure the lights and reflectors that are required by the local highway and transport authorities are in place, are clean, are in good

TRANSPORT SAFETY (cont.)

working order and can be seen clearly by all overtaking and oncoming traffic.

3. Do not exceed 55 MPH (88 KM/H) when transporting the machine. Reduce speed on rough roads or surfaces and when making turns.
4. Lock pintle hitch (or other hitch that is highway approved for size of load being towed) and attach safety chains to hitch when towing.

STORAGE SAFETY

1. Store the Patcher in an area away from human activity.
2. Do not permit children to play on or around the stored machine. Serious injury can result from slips and falls.
3. Make sure the unit is stored in an area that is firm, level and free of debris.
4. Store the patcher inside a building or cover with a weather-proof tarpaulin and support securely.

SAFETY DECALS

1. Keep safety decals and signs clean and legible at all times.
2. Replace safety decals and signs that are missing or have become illegible.
3. When replacing parts that displayed a safety decal or sign, be sure to replace those signs or decals.
4. Safety decals or signs are available from your authorized ROSCO parts dealer.

DECAL INSTALLATION

1. Be sure that the installation area is clean and dry. Use hot soapy water and dry the area thoroughly before installing decals.
2. Decide on the exact position by taking measurements and test fitting before you remove any of the backing paper.
3. For decals with no top protection paper, decide on the location for the decal and remove the smallest adhesive backing of the split backing paper.
4. Align the decal over the specified area and carefully press the small portion with the exposed adhesive backing in place.
5. Slowly peel back the remaining paper and carefully smooth the remaining portion of the decal in place.
6. Small air pockets can be pierced with a pin and smoothed out using a piece of decal backing paper.
7. If the decal has a protective top paper, use hot soapy water on the surface to which the decal is being applied. Leave wet. After deciding on the location, remove the backing paper and soak the decal in clean soapy water before applying. This will help prevent air bubbles in the decal.
8. Smooth the decal into place with a sponge and check for air bubbles. Small air pockets may be pierced with a pin and smoothed out. When the decal is completely smoothed out, carefully remove the top paper.

SAFETY DECAL LOCATIONS

The types of Safety Decals and their locations on the RA-2000 Patcher are shown in the illustrations that follow. Become familiar with the various Safety Decals, their locations on the equipment and **BE SURE** that you understand the warning message.

Think SAFETY! Work SAFELY!

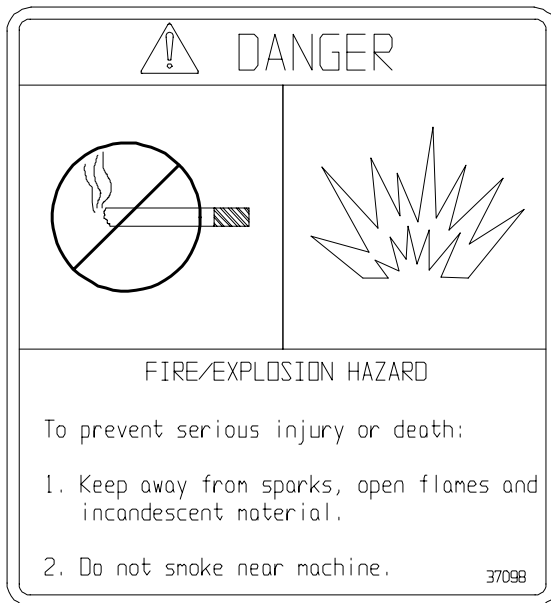

*Part # 37098
Located Near Fill on Emulsion Tank
& on Fuel Tank*

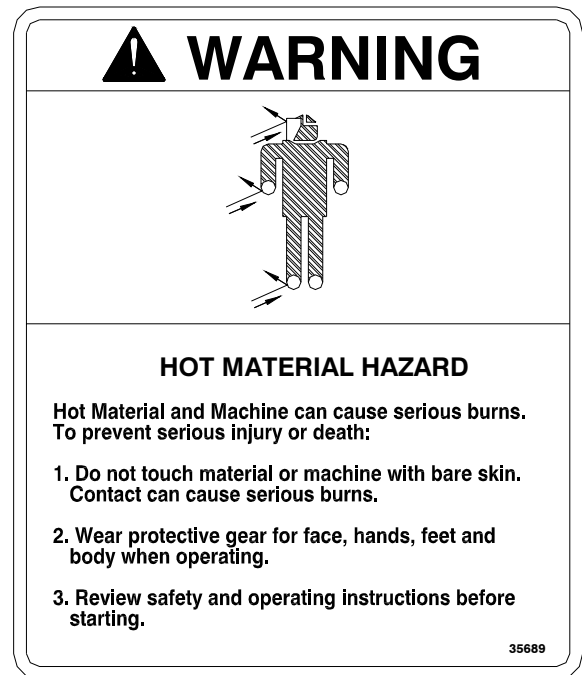

*Part # 35689
Located on Rear of Emulsion Tank*



*Part # 36202
Located on Emulsion Tank
Near Fender Step & Side Engine
Panel*

REMEMBER - If Safety Decals are illegible or missing because of wear or replacement of parts, new decals must be applied. New decals are available from your Authorized ROSCO Dealer.

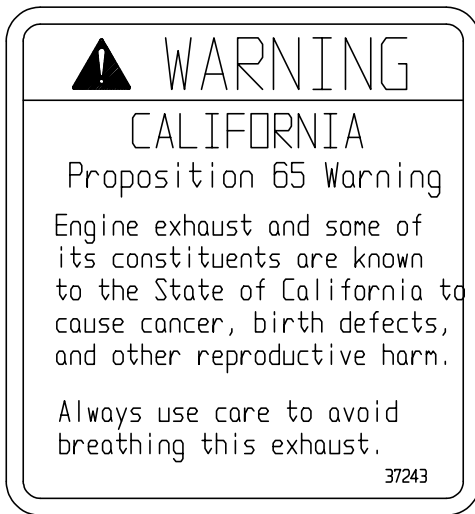

PART # 37243
Located on Side Engine Panel.



Part # 37169
Located on Each Fender

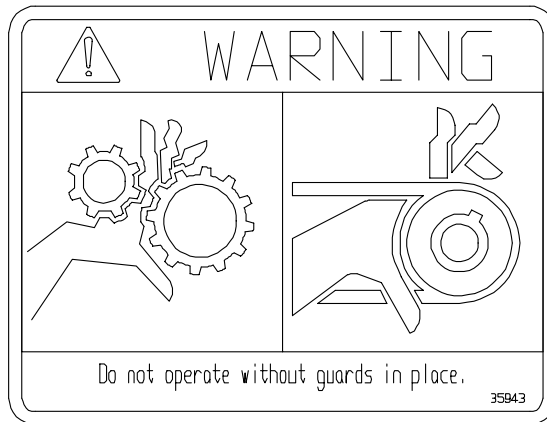

Part # 35943
Located on Front of Engine Compartment & Near Hitch.

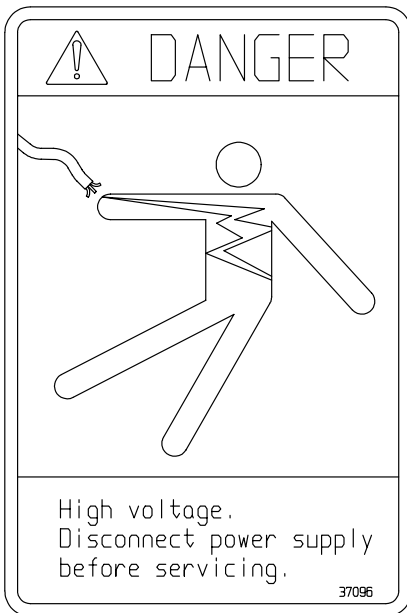

Part # 37096
Located Near Heater Controls on Front & Rear of Unit.

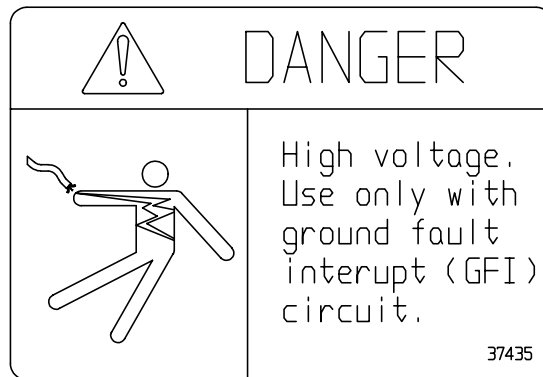

Part # 37435
Located Near Heater Controls on Rear of Unit.

REMEMBER - If Safety Decals are illegible or missing because of wear or replacement of parts, new decals must be applied. New decals are available from your Authorized ROSCO Dealer.

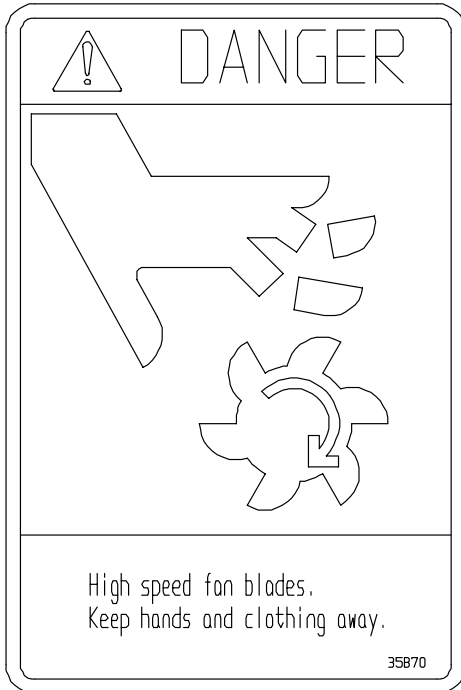

Part # 35870
Located on Engine Compartment.

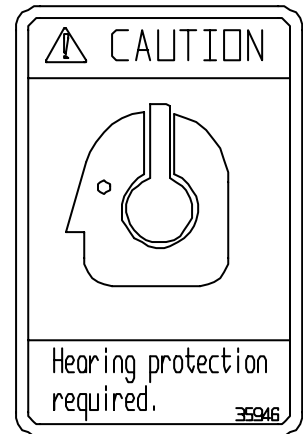
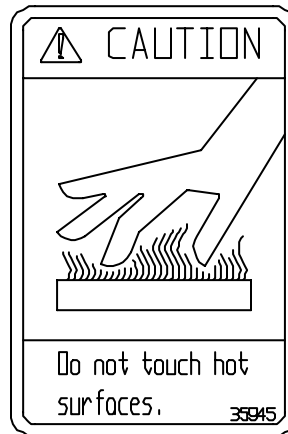

Part # 35945 & Part # 35946
Located on Blower.

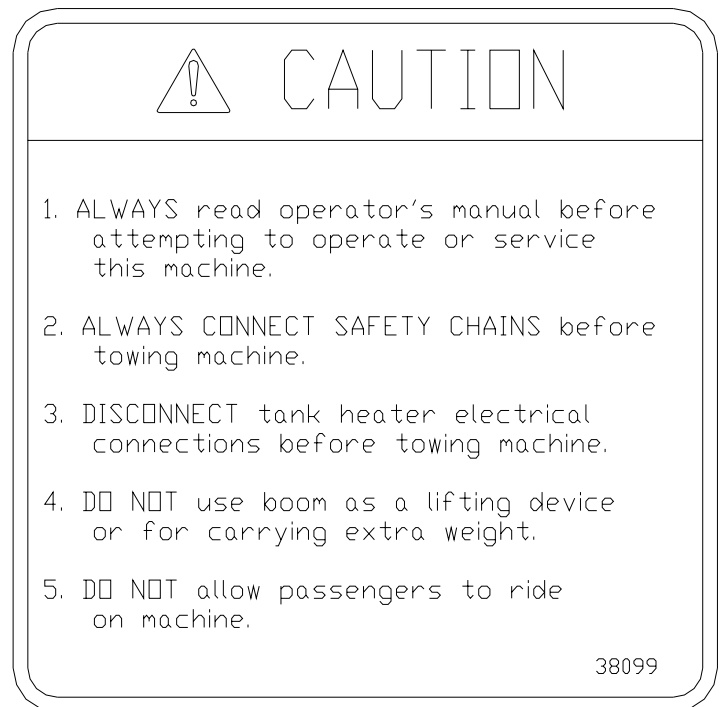

Part # 38099
Located on Rear of Emulsion Tank.

REMEMBER - If Safety Decals are illegible or missing because of wear or replacement of parts, new decals must be applied. New decals are available from your Authorized ROSCO Dealer.

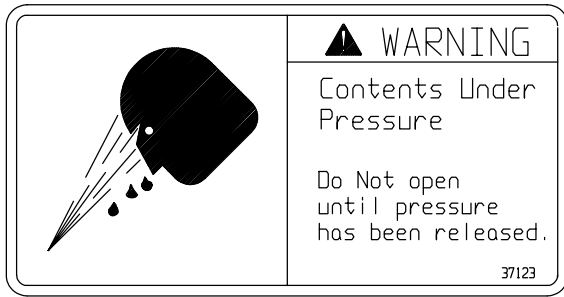

PART # 37123
Located on Emulsion Tank and Air Tank.



PART # D13
Located on Frame Near Hitch.

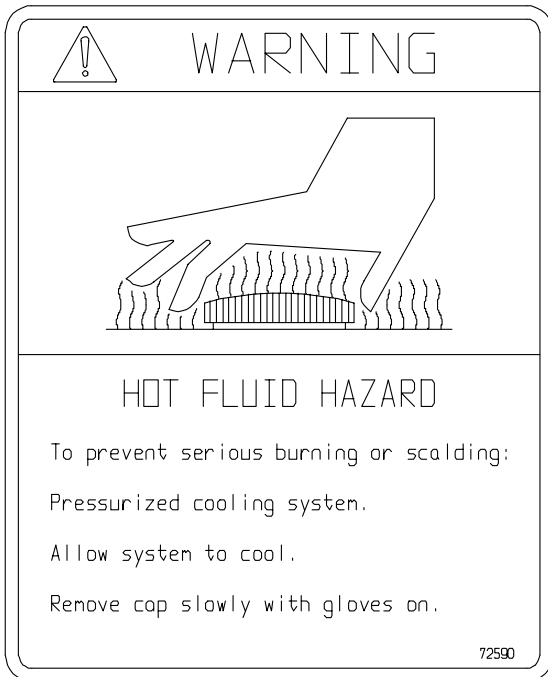

Part # 72590
Located on Engine Compartment.



Part # 38098
Located on Solvent Tank.

REMEMBER - If Safety Decals are illegible or missing because of wear or replacement of parts, new decals must be applied. New decals are available from your Authorized ROSCO Dealer.

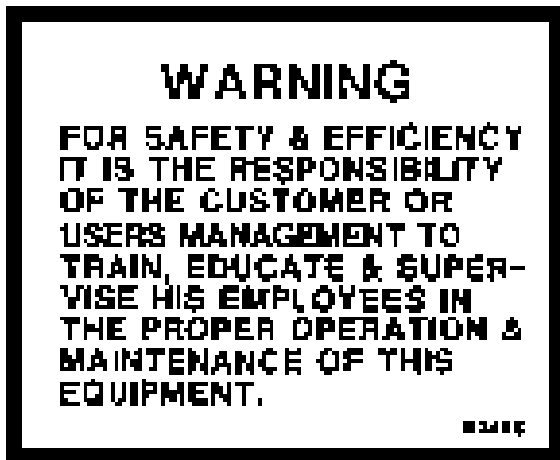

Part # 53495
 Located on Rear of Emulsion Tank.

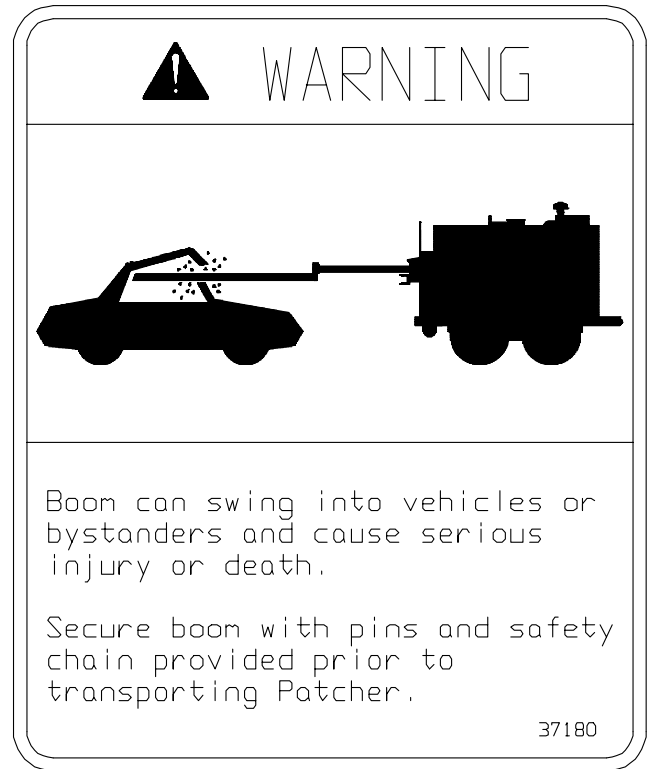

Part # 37180
 Located on Solvent Tank.



Part # 37129
 Located on Rear of Emulsion Tank.

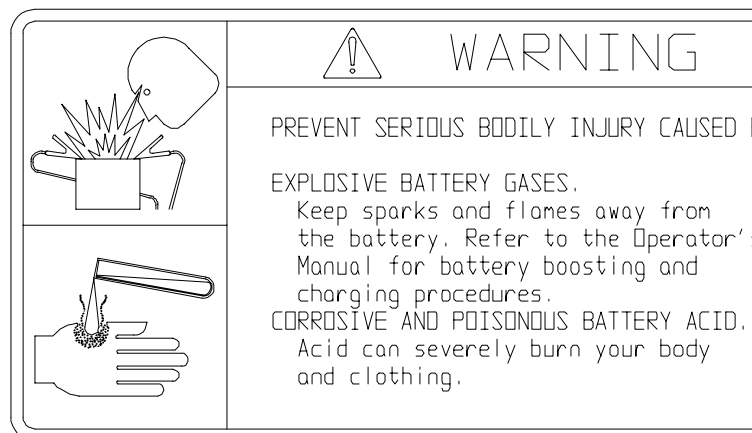

Part # 72627
 Located on Battery Compartment.

REMEMBER - If Safety Decals are illegible or missing because of wear or replacement of parts, new decals must be applied. New decals are available from your Authorized ROSCO Dealer.

MATERIAL CONSIDERATIONS

<i>Aggregate Selection</i>	3.2
General Guidelines	3.2
Electrical Charge of Aggregates	3.2
 <i>Liquid Asphalt Selections</i>	3.3 - 3.4
General Guidelines	3.3
Classifications and Grades of Liquid Asphalt	3.4
 <i>Liquid Asphalt Storage and Handling</i>	3.5 - 3.7
General Guidelines	3.5
Emulsified Asphalt Storage	3.5
Storage Facilities	3.6
Handling Liquid Asphalts	3.6 - 3.7

AGGREGATE SELECTION

General Guidelines

The ROSCO RA-2000 Patcher is designed to use a variety of aggregate types, but certain sizes and shapes have proved to produce the most durable patch. The following guidelines should be considered when choosing aggregate:

- A. Use clean aggregate. Dirty aggregate or aggregate with excessive fines will retard curing of the patch, lessen the life of the patch and limit adhesion of the emulsion to the aggregate. Dust content, or fines, should not exceed 3% passing through a 200 mesh sieve screen.
- B. The largest aggregate particles should be no more than twice the size of the smallest particle.
- C. For most patching applications, including potholes, cracks and thin overlays, aggregate of 1/4 or 5/16 inch (6.35 or 7.94 mm) is recommended. For larger areas and deeper repairs, aggregate up to 1/2 inch (12.7 mm) may be used.
- D. Use small aggregate to limit damage to vehicles caused by loose rocks.
- E. Smaller sized aggregate is recommended for patching as it will have less voids. Coarse grades may be used under special conditions such as base stabilization.
- F. Use angular particles with rough surface texture, such as crushed aggregate. These produce an interlocking effect with low absorption which produces the best patch.

Electrical Charge of Aggregates

Emulsified asphalts **MUST BE** used in the Patcher. These emulsions have an electrical charge. **UNDERSTAND THE DIFFERENCES.** The Asphalt Emulsion Manufacturers Association manual states:

Traditional theory holds that **anionic** emulsions (with a negative (-) charge on the asphalt droplets) perform best with aggregates having positive (+) surface charges — limestone and dolomite are examples.

The theory also holds that **cationic** emulsions (with a positive (+) charge on the asphalt droplets) perform best with aggregates having negative (-) surface charges — some examples are siliceous or granitic aggregates.

NOTE: It is important to consider the availability of suitable liquid asphalts, and their electrical charge, before selecting aggregate.

LIQUID ASPHALT SELECTION

General Guidelines

Recommendations for selecting a liquid asphalt to use with the Patcher are given below. Optimum results can best be obtained through trial of several different types of asphalt and aggregates. It is strongly recommended that you perform laboratory evaluations to determine the compatibility of an asphalt grade with an aggregate. For more information on liquid asphalt selection, obtain a copy of the following manual:

A Basic Asphalt Emulsion Manual
Manual Series No. 19 (MS-19)
from
The Asphalt Institute
Research Park Drive, P.O. Box 14052
Lexington, KY, USA 40512-4052
Telephone: (606) 288-4960 Fax: (606) 288-4999

The selection of a liquid asphalt for application by the ROSCO RA-2000 Patcher is generally dependent on the following considerations:

- A. Availability of various types of aggregate.
- B. Availability of various liquid asphalt grades.
- C. Climate conditions anticipated during application.
- D. Traffic conditions during application.

NOTE: The liquid asphalt most commonly used in the Patcher is a rapid-set grade of emulsified asphalt. The rapid-set CATIONIC CRS-2 or the ANIONIC RS-2 emulsions are designed to react quickly with aggregate thus forming a fast curing patch which can support traffic immediately after completion of the repair work. For this reason, most recommendations and directions found in this section will be directed at emulsified asphalts.

In certain climates, rapid-set emulsions may set up too quickly. Moderate-set emulsions are then recommended (MS-2 & CMS-2). It is important to note that some emulsion manufacturers have grades or mixtures which do not conform to industry standards. These materials are often tailored to local geographic conditions and may provide superior performance to the standard grades.

Classifications & Grades of Liquid Asphalt

As previously stated, there are a number of considerations when choosing liquid asphalts, and the best results can be obtained through trial of several different types of asphalt and aggregates. The following classifications and grades of liquid asphalts can be applied by the air patching method:

A. EMULSIFIED ASPHALT: Asphalt product made liquid by emulsifying asphalt cements with water and an emulsifier. When exposed to the atmosphere, the water evaporates leaving the asphalt cement to perform its function. The primary uses of emulsified asphalts are surface treatments, fog seal, prime coat, cold mix patching, road mix and tack coats.

Standard Grades of Emulsified Asphalt are:

1. **ANIONIC** (negative (-) charge): RS-1, RS-2, MS-1, HFMS-1, MS-2, HFMS-2, MS-2h, HFMS-2h, HFMS-2s, SS-1, SS-1h.
2. **CATIONIC** (positive (+) charge): CRS-1, CRS-2, CMS-2, CMS-2h, CSS-1, CSS-1h



WARNING: *DO NOT* mix emulsion types, *especially* anionic with cationic.

B. CUTBACK ASPHALT: Asphalt products made by blending asphalt cement with gasoline or naphtha for rapid cure grades, with kerosene for medium cure grades, or with non-volatile liquids like fuel oil for slow curing grades. When exposed to the atmosphere, the dilutents evaporate, leaving the asphalt cement to perform its function. Cold mix patching and road mix are the main uses of cutback asphalt.



WARNING: *DO NOT* use cutback asphalts in the RA-2000 Patcher.

C. ASPHALT CEMENTS: Basic asphalt refined from petroleum by fractional distillation. Hot mixes and surface treatments are the most common uses.



ATTENTION: *The RA-2000 is not capable of heating liquid asphalts to a high enough temperature to use asphalt cements. Highly viscous asphalts or asphalts that must be heated higher than 200° F (93° C) to become thin enough to pump **CANNOT BE USED** in the ROSCO RA-2000 Patcher. These asphalts will plug hoses and pipes.*

LIQUID ASPHALT STORAGE & HANDLING

General Guidelines

The Asphalt Institute has published a leaflet entitled "Storing and Handling Emulsified Asphalt" (CL-21). A portion of the guidelines contained in the leaflet are also listed in this section of the RA-2000 Patcher manual.

Emulsified Asphalt Storage

- A. Store emulsified asphalts as you would store water - between 50° F (10° C) and 185° F (85° C), depending on the grade of emulsion and the intended use.
- B. Use water as the heating medium for storage tanks with heating coils. Low pressure or waste steam also may be used if the temperature on the coil surface is controlled and limited to not more than 185° F (85° C).
- C. Store emulsified asphalts at the temperature specified for the particular grade. The higher viscosity rapid-set spray grades are stored at 125° F (52° C) to 185° F (85° C) since they are usually applied in this temperature range.
- D. **DO NOT** permit emulsified asphalt to be heated above 185° F (85° C). Elevated temperatures evaporate the water, resulting in an increase in viscosity and an asphalt layer in the tank. The materials then can no longer be used as intended and it will be difficult to empty the tank.
- E. **DO NOT** let emulsified asphalts freeze. Freezing breaks the emulsion, separating the asphalt from the water. The result will be two layers in the tank, neither suited for the intended use, and the tank will be difficult to clean.
- F. **DO NOT** allow the temperature of the heating surface to exceed 205° F (96° C). This will cause premature breakdown of the asphalt on the heating surface.
- G. **DO NOT** use forced air to agitate emulsified asphalts. This action may cause the emulsion to break down.

Storage Facilities for Emulsified Asphalts

The following guidelines have been provided to assist patcher owners and users in the development of proper storage facilities for their emulsified asphalts.

NOTE: It is the user's responsibility to consult the asphalt supplier or manufacturer for the construction of proper storage facilities for all types of asphalt materials.

- A.** Use insulated storage tanks for the best retention of heat and to protect the asphalts from freezing.
- B.** A skin of asphalt can form on the surface of emulsions when exposed to air. Use vertical tanks since they expose the least amount of the emulsion surface to the air. Most fixed storage tanks are vertical, but horizontal tanks are often used for short term field storage. Keep horizontal tanks full to minimize the area exposed to the air. When material will be stored in the tank over night or longer, leave the emulsion tank pressurized to prevent formation of an asphalt skin on the emulsion.
- C.** Side-entering propellers located about 3 feet (.9 m) up from the tank bottom may be used to prevent the formation of a skin on the surface. Large diameter, slow-turning propellers are best and should be used to roll the material over. **AVOID OVER MIXING.**
- D.** Tanks may be circulated from top to bottom with a pump. **AVOID OVER PUMPING.**
- E.** In tanks not equipped with propellers or a circulating system, a light film of kerosene or oil added to the surface of the asphalt can reduce formation of a skin.
- F.** Cathodic protection should be provided to avoid possible corrosion of tank walls and heating coils.

Handling Liquid Asphalts

The RA-2000 Patcher owner or user should consider the following guidelines when handling liquid asphalt materials, especially emulsified asphalts:

- A.** Use pumps with proper internal clearances for handling asphalt. Pumps with tight internal clearances could bind and seize.
- B.** Warm pumps to about 150° F (66° C) to ease start up. Apply mild heat to the pump packing or casing to free a seized pump. **DO NOT use open flames to warm pumps.**
- C.** Fill the pump with No.1 or No. 2 fuel oil when it is to be out of service, even for a short period of time, to ensure a free start up.
- D.** Flush the pump and circulating system lines and leave drain plugs open during periods when the equipment is not in service.

- E.** Protect pumps, valves and lines from freezing. Drain pumps or fill them with antifreeze according to the pump manufacturer's recommendation.
- F.** Transport liquid asphalt materials in trucks equipped with baffle (surge) plates to prevent sloshing.
- G.** Pump the emulsion with the suction line placed at the bottom of the storage tank to minimize contamination from an asphalt skin that may have formed.
- H.** Place inlet pipes and return lines at the bottom of storage tanks to prevent foaming.
- I.** Avoid repeated pumping and recycling since the viscosity may decrease and air may become entrained, causing the emulsion to become unstable.
- J.** If emulsions have been stored, mix emulsions by circulation prior to application.
- K.** **Remember** that emulsions with the same grade designation can be very different chemically and in performance.
- L.** **DO NOT** mix different classes, types and grades of emulsified asphalt in storage tanks, transports and distributors. Because it is hard to visually determine the difference between various emulsified asphalts, always make a trial blend of the newly delivered emulsion with the stored emulsion before pumping off. Check the trial blend for compatibility.
- M.** Use warm water for diluting emulsified asphalts and add the water **slowly** to the emulsion. **DO NOT** add emulsion to the water.
- N.** Check the compatibility of the water with the emulsion by testing in a flask before diluting grades of emulsified asphalt.

OPERATION SECTION

Theory of Operation -----4.2

Truck and Hitch Preparation -----4.3 - 4.4

 Tailgate Modifications -----4.3

 Truck Hitch Installation -----4.3

 Dump Box Position -----4.3

 Safety Chains -----4.3 - 4.4

 Lighting and Brake Connections -----4.4

 Hitching to Towing Vehicle -----4.4

Prestart and Asphalt Heating -----4.5 - 4.8

 Pre-start Instructions -----4.5

 Liquid Asphalt Heating - General -----4.5

 Asphalt Spraying Temperatures -----4.6

 Electric Heating System -----4.7

 Operation in Cold Climates -----4.8

 Combating Poor Visibility -----4.8

System Controls -----4.9 - 4.10

 General Instructions -----4.9 - 4.10

 Removal and Storage of the Boom -----4.10

Patching Instructions -----4.11 - 4.15

 General Instructions -----4.11

 Preparing to Patch -----4.12

 Cleaning Out the Hole -----4.12

 Tack Coating the Hole -----4.12 - 4.13

 Filling the Hole -----4.13 - 4.14

 Dust Coating the Patch -----4.14

 Stopping Application -----4.14 - 4.15

 Draining Air Tank -----4.15

THEORY OF OPERATION

The ROSCO RA-2000 Patcher was designed to provide an alternative to conventional methods of pothole patching. By understanding the method and procedures of its operation, Patcher owners and operators will discover that this machine can be used anywhere asphalt patching is needed: potholes, highway cracks, bridge approaches, eroded areas, parking lots and many other applications.

The Four Basic Steps of Patching With The RA-2000 Patcher:

FIRST, the pothole or patch area is cleaned by a blast of air to remove loose rocks, water and other debris as required.

For this operation, an engine driven high-volume air blower supplies a 3.5 inch (9 cm) diameter material hose with a continuous source of air. The operator uses the discharge nozzle at the end of the hose to direct the air flow towards the area to be cleaned.

SECOND, a tack coat of heated liquid asphalt is applied to seal the base material and provide an adhesive for the patch.

A pressurized emulsion tank supplies the liquid asphalt to the discharge nozzle through a separate hose. Liquid asphalt flow is regulated by a valve at the operator position, and is injected into the air stream through a pair of atomizing spray nozzles. The air flow in the material hose then carries the liquid asphalt out through the discharge nozzle where it is applied to the patch area by the operator.

THIRD, by using the controls at the operator position, the operator mixes the liquid asphalt with aggregate to form the patch material and fill the pothole or patch area.

Aggregate is introduced into the air stream by a slide gate in the aggregate feed hopper. When it reaches the discharge nozzle, the aggregate is partially coated by liquid asphalt from the atomizing nozzles and it leaves the nozzle as asphalt patch material.

FINALLY, a protective “dust coat” of aggregate is applied to the patch area.

The valve on the discharge nozzle controlling the liquid asphalt is turned off and dry aggregate is applied by the operator to cover the patch. This completes the process and within minutes traffic can drive over the patch without damage to it or to passing vehicles.

TRUCK AND HITCH PREPARATION

Tailgate Modifications

For RA-2000 Patcher operation, the tailgate on the tow truck dump body will require some modifications to allow the gravity flow transfer of aggregate from the truck to the Patcher. An opening measuring 6.5 inches (16.5 cm) wide and 9.5 inches (24.1 cm) tall must be cut into the center of the tailgate, usually starting .5 inch (1.27 cm) from the bottom of the tailgate. Then, a metal aggregate tube is welded to the tailgate to direct the flow of the aggregate to the hopper. A 5 inch (12.7 cm) hose is connected to the aggregate tube. The tube controls the aggregate flow into the hopper. To stop the flow of aggregate into the hopper during travel, simply raise the hose and fasten with rubber strap. (See page 7.35 for illustration.)

Truck Hitch Installation

In addition to the following specific guidelines for hitch installation on vehicles that will tow the RA-2000 Patcher, please consult the hitch manufacturer's instructions and guidelines prior to making any permanent hitch installation on the truck.

The RA-2000 Patcher is equipped either with a standard 2 1/2 inch (6.35 cm) nominal pintle eye hitch, an optional 3 inch (7.62 cm) nominal pintle eye hitch, or an optional 2 5/16 inch (5.87 cm) ball coupler hitch. The hitch section is removable and can be adjusted on the frame to allow for a towing height of 16 to 28 inches (40.6 to 71.1 cm). This allows the owner or operator to choose the type of hitch and height at which it will be installed.

A general rule to follow when installing a hitch on the RA-2000 Patcher towing vehicle is that the truck hitch point should be located approximately 21 inches (30.5 cm) forward of the tailgate discharge hole. However, it is recommended that the hitch installer simulate a hooked-up condition to locate the best possible hitch position.

Truck Hitch Installation (cont.)

To simulate a hooked-up situation, the truck should be positioned:

1. After the tailgate modifications are made and all components are in place.
2. Before attaching any hitch components to the truck.
3. Close enough to the RA-2000 Patcher so the hose will be long enough to complete a turn.

Unless the truck hitch will have to be installed unusually high or low, the RA-2000 hitch height adjustment should be set at its **midpoint** for this simulation. When the final installation is made, the hitch should be adjusted so the RA-2000 is always level when in operation.

Dump Box Position

During "hooked-up" simulation, it is recommended that the installer raise and lower the dump box after connecting the discharge hose to the tailgate aggregate tube. After testing the dump box positions, the operator should check that the discharge hose is long enough to complete turns in either direction. Excess hose can be removed if desired. Once this has been verified, the hitch can be installed with the confidence that proper feeding of aggregate to the RA-2000 Patcher will be accomplished regardless of dump box position.

Safety Chains

The RA-2000 Patcher is equipped with two (2) safety chains. The truck hitch **must** include provisions for attaching safety chains. The safety chains should be installed in a cross pattern for added security. The safety chains are designed to

Safety Chains (cont)

carry the Gross Vehicle Weight (GVW) of the RA-2000 Patcher. Any modification to the safety chains or attaching shackles is prohibited.

DANGER: *Always connect safety chains to the towing vehicle **before** transporting the RA-2000 Patcher. If the Patcher becomes unhitched while being towed without the safety chains connected, the unit can collide with traffic or pedestrians causing serious injury or death.*



Lighting and Brake Connections

Connect the lights and brakes to the towing vehicle before moving or transporting the RA-2000 Patcher. Install the receptacles on the towing vehicle to match the connectors supplied with the Patcher. Do this at the same time the hitch is installed. This allows the installer to verify that cable lengths are adequate for all turning situations. The connector supplied with the RA-2000 Patcher is six (6) feet (1.8 m) long and can be cut off and shortened if necessary.

The six (6) pin connector is standard on most RA-2000 Patchers. However, a seven (7) pin connector is available from ROSCO (part #32889). Mating connectors for the seven (7) pin connector, to be attached to the towing vehicle, are also available from ROSCO (part #34803).

A safety brake disconnect cable is provided to provide emergency stopping of the RA-2000 Patcher if it become disconnected from the towing vehicle while traveling. The cable is located on the

Lighting and Brake Connections (cont.)

underside of the Patcher hitch assembly and should be attached to a separate connection from the safety chains. If the Patcher becomes unhitched from the towing vehicle, the cable will pull a safety pin that will electrically activate the brakes on the Patcher with power from the RA-2000 Patcher battery system.

Hitching to Towing Vehicle

Connect the RA-2000 Patcher hitch to the towing vehicle. Adjustment can be made both at the hitch and on the Patcher frame. The range of adjustment is 18 to 26 inches (45.7 to 66 cm) above ground level. Always adjust the hitch for level operation.



WARNING: *Always connect the safety chains, brake controls and light connector to the towing vehicle **before** transporting the RA-2000 Patcher to reduce the possibility of collisions.*

PRE-START & ASPHALT HEATING

Pre-Start Instructions

WARNING: Always wear appropriate protective gear. This includes but is not limited to **boots, protective glasses/goggles or face shield, heavy gloves, protective coveralls, hearing protection, protective head gear, and orange safety vest.**



1. Fill the tow vehicle dump box with relatively clean aggregate. Aggregate that is too large or contains excessive fines (dust) will negatively affect the patching process. Refer to Section 3 in this manual, "**Material Considerations**", for more information on selecting aggregate.

DANGER: DO NOT smoke around the machine. Fuel, emulsion and the fumes from both can explode when exposed to flame or heat from smoking.



DANGER: Vent valve (ball valve) on top of tank must be opened and **all** pressure relieved **before** opening or filling the tank. Pressure gauge near the vent valve must read 0 (zero) psi.

2. Fill the asphalt tank to the desired level with high quality liquid asphalt. Refer to Section 3 in this manual, "**Material Considerations**", for more information on selecting emulsions or other liquid asphalts. **DO NOT OVER FILL.** Leave at least 2 inches (5.1 cm) for expansion when heated. For best results, fill the asphalt tank daily. This will reduce sludge build-up on the inside of the tank.

Pre-Start Instructions (cont.)



IMPORTANT: The asphalt tank must be cleaned thoroughly before switching types of emulsion or liquid asphalt.

3. Fill the flush tank (solvent tank), located with the fuel tank at the rear of the Patcher, with solvent. Keep the solvent tank full so that the lines can be cleaned at any time.
4. Be sure vent valve on the asphalt tank is returned to the normal operating position. Also, open **both** asphalt supply valves at the discharge nozzle.
5. After the aggregate hopper, asphalt tank and flush tank have been filled, the Patcher is ready to operate.
6. Pressurize the asphalt tank by turning on the air valve located between the emulsion tank and the rock hopper on the left side of the machine. The air regulator near the air valve should read between 30 and 60 psi when the tank is fully pressurized.

Liquid Asphalt Heating - General

The RA-2000 Patcher is equipped to heat liquid asphalt by using an ordinary 120-volt (240-volt for European models), 20 amp AC household current. The temperature of the asphalt can then be maintained in the field using heat generated from the engine's liquid cooling system. Consult the chart that follows and determine the proper application temperature for the grade of asphalt being used. Set the thermostat control to this desired temperature **before** going on with heating procedures.

Spraying Temperatures

Refer to supplier information and the adjoining chart for recommended spraying temperatures of various types of liquid asphalts.

DANGER: Heating liquid asphalts can be dangerous and if done improperly, can cause serious injury. Refer to **Section 1, Safety Considerations**, before attempting to heat liquid asphalts.



WARNING: DO NOT exceed recommended asphalt temperatures. Serious personal injury may result. Refer to the recommendations in the "**Asphalt Spraying Temperatures**" section that follows.



Asphalt Spraying Temperatures

The highest temperature used for spraying should be that at which no fogging occurs when the asphalt material leaves the discharge nozzle.

Emulsified Asphalts

Type & Grade	Degrees F.	Degrees C.
RS-1 -----	70 -140 -----	21 - 60
RS-2 -----	125 -185 -----	52 - 85
MS-1 -----	70 -160 -----	21 - 71
MS-2 -----	70 -160 -----	21 - 71
MS-2h -----	70 -160 -----	21 - 71
HFMS-1 -----	70 -160 -----	21 - 71
HFMS-2 -----	70 -160 -----	21 - 71
HFMS-2h -----	70 -160 -----	21 - 71
SS-1 -----	70 -160 -----	21 - 71
SS-1h -----	70 -160 -----	21 - 71
CRS-1 -----	125 -180 -----	52 - 82
CRS-2 -----	125 -180 -----	52 - 82
CMS-2 -----	70 -160 -----	21 - 71
CMS-2h -----	70 -160 -----	21 - 71
CSS-1 -----	70 -160 -----	21 - 71
CSS-1h -----	70 -160 -----	21 - 71

Electric Heating System

The material in the asphalt tank is heated by two electrical AC elements, immersed in the engine cooling system coolant, one at either end of the tank. The temperature control is located at the rear of the asphalt tank under an access door (see *Figure 4-A below*). Refer to the "**Asphalt Spraying Temperatures**" chart in this section for desired emulsion temperature or check with your emulsion supplier. To set the temperature control, use a small screwdriver to move the temperature control pointer to the desired temperature. The numbers on the temperature control indicator on a standard unit indicate degrees Fahrenheit.

Electric Heating System (cont.)

The element indicator light will come on during the heating cycle.

The electrical plug can be connected to a standard 120-volt minimum (240-volt for European models) 20 amp AC outlet. Normally, the heater elements are adequate for heating. However, in cold weather conditions, the patcher may need to be parked inside a warm building to warm the asphalt more quickly.



DANGER: When using the RA-2000 electrical heating system, use only with an outlet protected by a Ground Fault Interrupt (GFI) circuit.

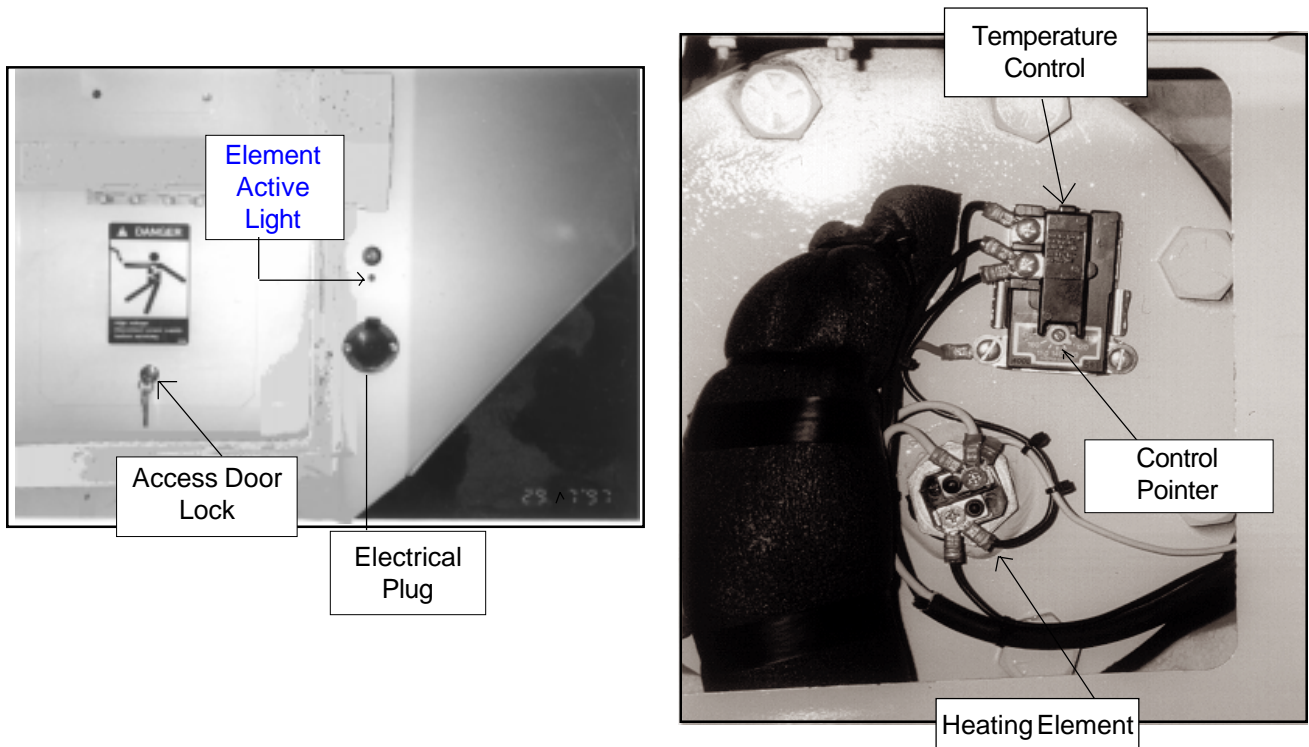

Figure 4-A
Electric Heater Temperature Control

Operation in Cold Climates

The spray patchers manufactured by ROSCO are designed for normal operation at temperatures of 40° F (4° C) or higher. The machines can be used successfully at colder temperatures with special considerations to the following items.

1. Freezing aggregate: **DO NOT** allow the aggregate to freeze. If the aggregate freezes, it will not flow freely in the gravity feed system.
2. Emulsion types: Special emulsions may be needed when operating at temperatures below freezing.
3. Patch quality: Patches made below freezing are subject to conditions that lower the quality of the patch. Some, but not all conditions, include ice in the pothole, freezing of the emulsion before it breaks, cooling of the emulsion and operator experience.

The RA-2000 has made patches at temperatures as low as -15° F. (-26° C). The life of these patches, on average, is less than those made at 40° F. (4° C.) and above, but compare well to other patching techniques.

Combating Poor Visibility

Increasingly, asphalt maintenance equipment is being used during periods of poor visibility such as during fog, smog and at night. Usage during these and similar conditions creates safety hazards for the workers, bystanders and passing traffic. People can be injured or killed by the equipment, traffic, other obstructions or by driving into ditches, holes or down embankments.



WARNING: *If you will be operating under the above mentioned conditions, the equipment **must be** equipped with front and rear lighting options as well as back up lights.*

Equipment must also be equipped with shielded, rotating beacons. This prevents eye strain for the operator, which can result in loss of visibility. Use conspicuous tape (reflective) on the sides of all machines that may be used at night.

Be sure all personnel wear reflective vests.

Install impact barriers (movable or stationary) to protect the workers from traffic and to help direct the traffic flow away from any road hazards.

SYSTEM CONTROLS

General Instructions

Before patching with the RA-2000 Patcher, the operator should become familiar with the controls of the machine. It may be necessary to have a factory or dealer trained representative conduct a training session on how to operate the RA-2000 Patcher before actually using the machine.

The instrument panel is located on the rear of the emulsion tank and is illustrated in *Figure 4-B*. This control box contains the ignition switch, gauges and fuse box that allow the Patcher to operate.

When operating the RA-2000 pay particular attention to the engine gauges to prevent engine damage from overheating or low oil pressure.

The Mechanical Boom control handle contains a series of electronic switches that operate the engine throttle, solvent pump valve, aggregate flow solenoid and signal horn. A manual valve controls the flow of emulsion to the nozzle.

The 3-way valve on the lower rear of the emulsion tank allows the operator to shut off all liquid to the boom lines, start the emulsion flow, or clean the line with solvent. (See *Figure 4-C* on the next page.)

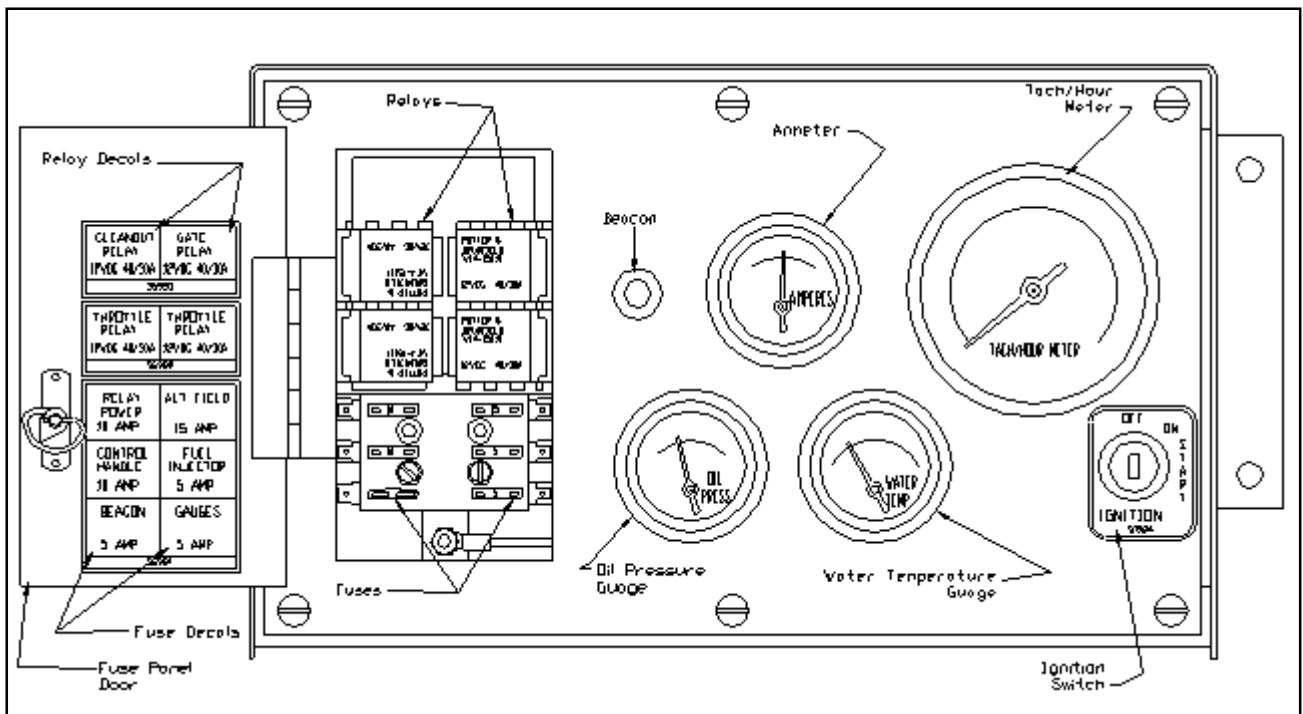
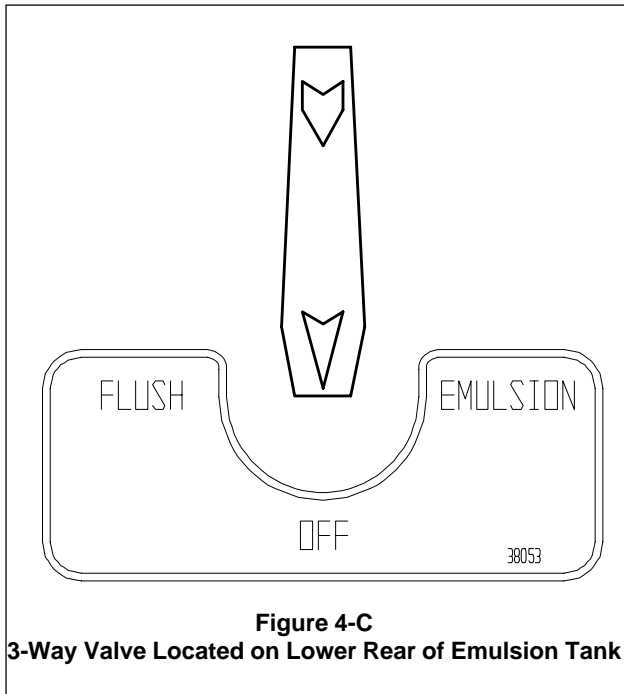

Figure 4-B
Instrument Panel

General Instructions (cont.)



Always be sure to start the engine and allow it to warm up to operating temperature before starting to patch. Check the engine gauges for any signs of trouble. If there are any problems such as low oil pressure or high water temperatures, do not use machine until the problem has been corrected in order to avoid serious engine damage.

Removal and Storage of the Boom

To remove the boom from the locked position:

1. Remove the carriage strap located above the fender from around the boom.
2. Remove hose from the cradle and nozzle storage box.
3. Be sure the transport screw lock on the boom frame upright is unlatched. Release the boom latch and pull the boom toward you to clear the latch.
4. Pull the boom back from the boom frame upright. After making sure the boom is at the proper height for use, you are ready to patch.

To store the boom:

1. Swing the end of the boom to the storage side of the unit. Push the boom toward the front of the unit.
2. Push the boom toward the Patcher until the boom latch locks. If the unit will travel more than a short distance or over rough roads,, lock the transport screw lock to secure the boom.
3. Push down on the operator handle to help raise the end of the nozzle into the storage box. If the unit will only travel a short distance, the nozzle may be hooked on the hook provided on the front of the storage box. However, if your unit will travel a long distance or over rough roads, put the nozzle in the storage box.
4. Replace the hose in the cradle and hook the strap. Be sure all hoses are on top of the fender before transporting the unit.

PATCHING INSTRUCTIONS

General Instructions

In the following patching instructions, components and system controls of the RA-2000 Patcher are illustrated in *Figures 4-C and 4-D*.



SPECIAL NOTE: At the beginning of each day, the solvent must be emptied from the emulsion line. This procedure should be done as close to the job site as possible to prevent the set up of new asphalt in the nozzle. Run the engine long enough to pressurize the asphalt tank. Then shut off the engine. With the **3-way Valve** (Figure 4-C) on the lower rear of the asphalt tank in **Emulsion** position and the **Rock Flow Switch** (item B, Figure 4-D) **OFF**, place the waste catch bucket under the nozzle and be sure that both asphalt supply valves at the discharge nozzle are open. Push the **Emulsion Control Lever** slowly **ON**. Leave on until all solvent is removed and liquid asphalt begins to flow from the nozzle. Pull the **Emulsion Control Lever** back to stop the flow. If you must travel to the job site, replace the discharge nozzle in the cradle and move the boom to the travel position and lock in place.

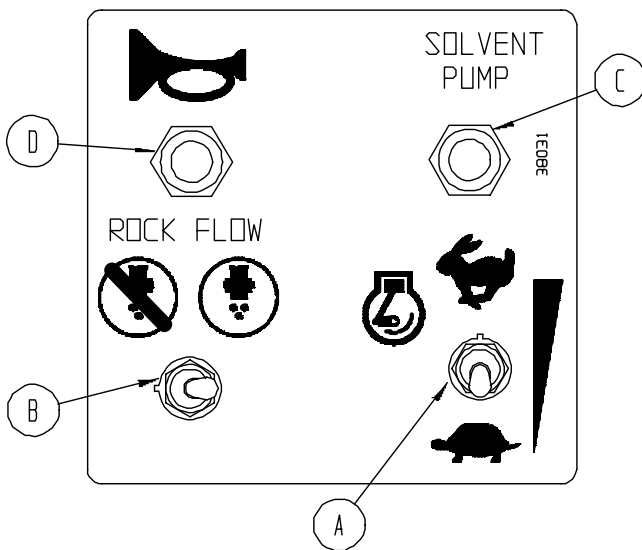

Figure 4-D
Operator Controls on Boom



WARNING: Be sure engine is **OFF** before purging the asphalt lines. The extra force of the operating blower can cause the emulsion or solvent to splash out of the catch bucket, possibly spraying the operator or nearby workers.

DANGER: DO NOT smoke around the machine. Fuel, emulsion and the fumes from both can explode when exposed to flame or heat from smoking.



WARNING: Read and understand the operator's manual and all safety signs before operating the RA-2000 Patcher.

Preparing to Patch

1. Position the Patcher so that the extended boom is within acceptable operating range of the pothole or patch area.
2. Set the truck parking brake. Turn on the beacon with the **Beacon Switch** (Figure 4-B Page 4-9) to warn traffic to go around the truck.
3. Remove boom and adjust height. Position the operator's handle located near the controls on the boom. The nozzle should be 12 to 14 inches (30.5 to 35.5 cm) above the pothole. Check that both asphalt supply valves at the discharge nozzle are open.
4. Start engine. Be sure all gauges are within the normal readings. Warm the engine to operating temperature before starting to patch. Put the 3-way valve (Figure 4-C) in the **Emulsion** position.

Cleaning Out the Hole



WARNING: Wear appropriate ear protection when exposed to excessive noise. Permanent loss of hearing can result from prolonged exposure.

WARNING: Wear protective gear for face, hands, body and feet to protect from being hit by aggregate or hot material. If hot material touches the skin, flush with cool water and get medical attention.



1. Using the manual throttle control, increase the engine speed so the blower will produce enough air to clean out the hole to be patched (normally 1200 to 1300 RPM).
2. Clean out the hole using the operator handle to move the nozzle around the entire pothole

Cleaning Out the Hole (cont.)

- and an area 4 to 6 inches (10 to 15 cm) around the outside edges of the pothole.
3. The hole can be damp, but should have very little water in it.
 4. For more air volume, increase the engine speed, but DO NOT exceed 2300 RPM.

Tack Coating the Hole

1. Raise the discharge nozzle to a patching height of 24 to 48 inches (61 to 122 cm) above the hole by tilting the nozzle end of the boom up. Reduce the engine RPM to 1300.
2. Push the **Emulsion Control Lever** forward to start the emulsion spray. By pushing the lever forward or pulling it back, the operator can control the emulsion to achieve the desired flow. Begin spraying the edges, sides and bottom of the pothole, moving the boom to get complete coverage. The liquid asphalt should be carried out of the nozzle in a mist.

If excessive dribbling occurs, try one or more of the following:

1. Increase the engine speed (blower speed) slightly for more air flow.
2. Check that both the emulsion line valves on the discharge boom, near the nozzle, are completely open.
3. Slightly close the **Emulsion Control Lever**, or in some cases, open it more. Dribbling can occur because of too much asphalt spray or not enough asphalt spray to properly mix with the air stream.

Tack Coating the Hole (cont.)

4. Clean the emulsion spray nozzles (inside the discharge nozzle). Emulsion spray nozzles can be cleaned by flushing with solvent, applying hot air to their exterior or unplugging with a pick.
5. Replace emulsion spray nozzles.
6. Increase air pressure at the regulator. This increases discharge pressure in the emulsion tank and at the spray nozzles.
7. Increase the liquid asphalt material temperature.

NOTE: In general, the blower speed and asphalt tank pressure should be set as low as possible, yet high enough to produce a good asphalt spray coverage (normally 1200 RPM and 45 psi).

Filling the Hole

1. After the hole is tack coated, activate the aggregate delivery system by toggling the **Rock Flow Switch** (item B, Figure 4-D). Do this while the **Emulsion Control Lever** is **ON** so that liquid asphalt will coat the aggregate as it emerges from the nozzle.

NOTE: There is a slight delay in aggregate flow to the nozzle, so the **Rock Flow Switch** should be activated in advance of need.

2. To insure an even patch, move the nozzle around the damaged area while repairing the pothole. A proper asphalt/aggregate mixture can be maintained by adjusting the **Emulsion Control Lever**.

Filling the Hole (cont.)

3. Adjust the **Emulsion Control Lever** so that only a slight covering of asphalt is applied to the aggregate. The normal tendency is to apply too much asphalt, which causes slowed curing rates and is a waste of materials. The final appearance should be a darkly mottled or heavily speckled patch, but not entirely black. Each operator tends to develop certain techniques that work for his/her individual needs. The following suggestions may be helpful in establishing your technique.
 - a. Fill large shallow holes from the furthest point out and work towards the machine in semi-circular arcs.
 - b. Large deep holes should be patched by filling the deepest point of the hole first and then working outwards, building a slight ledge or shelf for successive layers.
 - c. If excessive rock bounce is encountered, reduce blower speed and/or raise the discharge nozzle away from the surface of the patch. More asphalt may be needed to help the material stick together and to the patch.
 - d. If the aggregate is not being coated with emulsion, try holding the nozzle stationary to see if some of the pile created is not coated with emulsion. Poor coating of the aggregate may be caused by several things. The emulsion pressure may be set too high, or the rock is of a larger size and does not coat as well. Reduce the air pressure if too much emulsion pressure is the problem. If the rock is too large, try using .25 inch (6.35 mm) rock.

Filling the Hole (cont.)

- e. Do not over fill the pothole. The natural tendency is to fill the pothole slightly above level to allow for compaction. The pothole should be filled flush to the existing road surface. Any extra fill will only create a rough spot in the road surface.
4. Compaction of the patch in the pothole occurs by the impact as the material is applied (see **Theory of Operation**). No other compaction is necessary. However, compaction won't hurt this type of patch. Compaction will provide a more finished appearance, and should be done after applying a dust coat to the patch.

Dust Coating the Patch

1. Turn the **Emulsion Control Lever OFF**.
2. Elevate the discharge nozzle slightly and lightly cover the patch with dry aggregate. The purpose of the dust coat is to help prevent the tires of passing vehicles from picking up asphalt.
3. Turn the **Rock Flow Switch** (item B, Figure 4-D) **OFF** to stop the flow of aggregate. There is a 5 second delay from the time the switch is turned **OFF** until the rock flow stops because of the rock already in the line. The operator must anticipate this to be sure not to over coat the patched area.
4. Put the discharge boom in the travel position.

NOTE: Some dribbling from the nozzle occurs which may get on the machine. Be sure the discharge nozzle is in the storage box and the boom is secured if traveling a long distance or traveling at highway speeds

Dust Coating the Patch (cont.)

5. Slow the engine speed on the patcher.
6. Drive slowly to the next hole.

Stopping Application

When stopping application for a short time, leave the engine running to keep the asphalt and the other components heated to avoid emulsion set up. If you are finished for the day or a long period of time, flush out the asphalt delivery system.

To clean the asphalt lines:

1. Shut **OFF** the engine. Turn the **3-way Valve** (Figure 4-C) on the asphalt emulsion tank to **Flush** position.

WARNING: Be sure engine is **OFF** before purging the asphalt lines. The extra force of the operating blower causes the emulsion or solvent to splash out of the catch bucket, possibly spraying the operator or nearby workers.



DANGER: DO NOT smoke around the machine. Fuel, emulsion and the fumes from both can explode when exposed to flame or heat from smoking.



2. Position the waste catch bucket below discharge boom nozzle.
3. Push the **Emulsion Control Lever** forward to open the emulsion line. Then press the **Solvent Pump Button** (item C, Figure 4-D) and hold down until solvent begins to spray from the line instead of emulsion.

Stopping Application (cont.)

4. Release the **Solvent Pump Button** (*item C, Figure 4-D*). Push the **Emulsion Control Lever** backward to shut **OFF** the line when solvent begins to spray from the nozzle instead of liquid asphalt.
5. Close both valves on discharge boom nozzle.
6. Put cover on the waste catch bucket and store or dispose.
7. When disposing of waste asphalt or emulsion at the end of each work day, be sure to check your local guidelines for proper method of disposal of waste emulsion and cleaning solutions.

DANGER: *The Ball Valve Lever must be in the open position to open the vent valve (ball valve) on top of the tank to relieve tank pressure. All pressure must be relieved before opening or filling the asphalt tank. Pressure gauge near the vent valve must read 0 (zero) psi.*



8. Store and secure the boom. (See page 4-10)

NOTE: In some cases waste material can be added back into the emulsion tank. If you are going to add emulsion back to the tank, take the following precautions:

- a. Always screen material going back into the tank for any coagulated particles, rock or debris.

Stopping Application (cont.)

- b. Always pour waste into the emulsion tank **before** adding new emulsion. Never add waste emulsion to the top of a load as it will create a film on top and will not mix in.

Draining Air Tank

At the end of each day, the operator should drain the air tank to remove any moisture that may have accumulated during operation.

1. After cleaning the lines and putting the boom away, the operator should move to the engine side of the unit. The air tank drain cable is located near the air tank on this side.
2. Be sure there is air pressure in the tank.
3. Pull this cable and hold open until no more moisture comes out of the drain.
4. Release the cable to close drain.

MAINTENANCE SECTION

<i>General</i>	5.2
<i>Engine Maintenance</i>	5.2 - 5.6
Fuel Requirements	5.2 - 5.3
Cold Weather Starting	5.3
Fuel Filter and Water Separator	5.4
Crankcase Oil	5.4
Air Intake System	5.4 - 5.5
Radiator and Coolant	5.5
Battery	5.6
Engine Belts	5.6
<i>Electrical Maintenance</i>	5.7
<i>Patching System Maintenance</i>	5.8 - 5.10
Air Blower	5.8 - 5.9
Liquid Asphalt Tank	5.9
Removing Broken Asphalt Emulsion	5.9 - 5.10
<i>Chassis and Running Gear Maintenance</i>	5.11 - 5.12
Tires & Wheels	5.11
Hitch and Lighting	5.11 - 5.12
Axles & Brakes	5.12
<i>Storage</i>	5.13 - 5.15
Machine Storage - Engine	5.13
Machine Storage - General	5.13
Removing Machine From Storage	5.13 - 5.14
Positive Displacement Air Blower Storage	5.14
Removing Positive Displacement Air Blower From Storage	5.14 - 5.15
<i>Lubrication</i>	5.15
Lubrication chart	5.15
<i>Preventive Maintenance Chart</i>	5.16
<i>Bolt Torque Chart</i>	5.17

GENERAL MAINTENANCE

The suggestions and recommendations contained in this manual for maintenance should be followed as closely as possible to obtain long life and best performance from the ROSCO RA-2000 Patcher. **REMEMBER:** Do not attempt to service or repair major components such as engine, blower etc., unless authorized to do so by your ROSCO Dealer/Distributor. **Any unauthorized repair will void the warranty.**

PROPERLY MAINTAINED EQUIPMENT IS SAFE EQUIPMENT! The user of this product is responsible for inspecting the RA-2000 Patcher daily, and for having parts replaced or repaired when continued use of the machine would cause damage or excessive wear to other parts. General daily inspection of the RA-2000 Patcher should include observation for missing guards, loose bolts, fluid leaks, worn or damaged hoses, debris or dirt accumulations which could cause a potential service or safety problem.

A PREVENTIVE MAINTENANCE CHART is included at the end of this section as a guide for establishing a preventive maintenance schedule.

The first and most important requirement for satisfactory performance is a **clean machine**. Many failures in the field result from neglecting ordinary adjustments, lubrication and cleaning.

DO NOT modify the RA-2000. Any unauthorized modification may impair the function and/or safety and affect the working life of the equipment. **Any unauthorized repair will void the warranty.**

ENGINE MAINTENANCE

General

In addition to the following maintenance recommendations, consult the Cummins Diesel Engine Manufacturers' Operation & Maintenance Manual (Rosco Part Number 40034) for detailed instructions. A copy of this manual was provided with the RA-2000 Patcher at the time of its shipment from the factory. If additional copies are needed, they can be obtained from Rosco through your local authorized ROSCO Dealer/Distributor or through a local equipment dealer who sells or services the particular engine make that your Patcher is equipped with.

Fuel Requirements

Use only clean, good quality ASTM No. 2-0 or No. 2-D climatized diesel fuel. If the Patcher will be used often in cold weather (below 20° F, -6.6° C), use blended fuels or No. 1 diesel fuel to prevent gelling of the fuel filters. The use of No. 1 diesel fuel may reduce the engine performance by approximately 10%.

Fuel Requirements (cont.)

ATTENTION: DO NOT use contaminated fuel. Fuel contaminated by water or dirt can cause severe damage to engine components. Fuel tanks contaminated with water will promote the growth of microbes which form a "slime" that can clog fuel filters and lines.



Cold Weather Starting

The direct-injected Cummins Diesel Engine starts well in cold weather. If it is necessary to use ether as a starting aid, do it promptly. Read and follow the steps below. Read and follow the ether manufacturer's recommendations for safe and effective use.

1. Set throttle to idle.
2. Have someone crank the engine while you spray starting fluid into the air cleaner for no more than two (2) seconds at a time. **Never** remove the air filter element and spray ether directly into the air inlet piping or the intake manifold.
3. Be sure that engine oil pressure is indicated on the gauge within 30 seconds after starting.

Cold Weather Starting (cont.)

DANGER: DO NOT use ether near open flames or with pre-heater or glow-plugs. The combination can cause an explosion.



DANGER: DO NOT inhale ether starting fluid fumes. They can cause serious injury.



ATTENTION: DO NOT use excessive amounts of ether when starting the engine. The use of too much ether will cause engine damage.

If the unit is equipped with an Automatic Ether Injection System, follow these steps for starting in cold weather.

1. Set throttle at idle.
2. While cranking the engine, inject a metered amount of ether by pushing the Ether Injection button.
3. Be sure the engine oil pressure is indicated on the gauge within 30 seconds after starting.
4. **Never** inject ether for more than 2 seconds at a time.

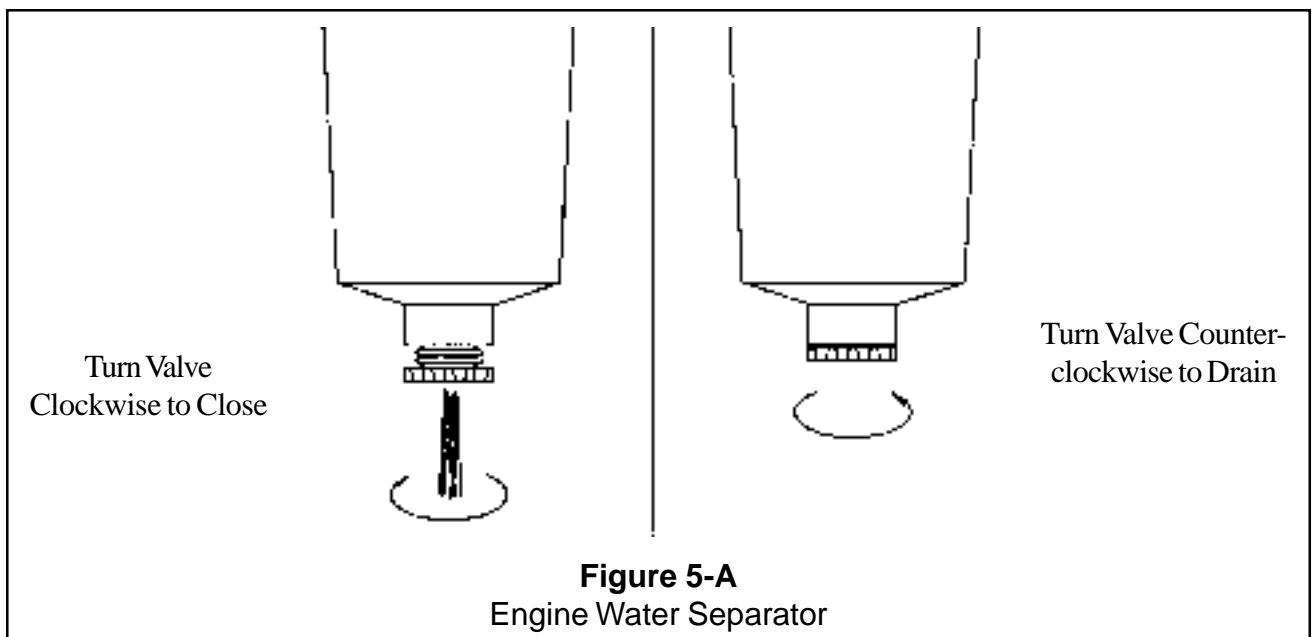

Fuel Filter and Water Separator

Diesel engine injection systems use fuel for lubrication of close tolerance internal engine parts. Proper maintenance of the fuel filters and the fuel tank are required for continued top performance and to prevent damage to internal engine components.

The engine fuel filter and water separator are located on the left side of the engine. A drain valve is provided on the bottom of the water separator (Figure 6-A).

Before operating the engine, use the valve to drain a small quantity of fuel from the water separator into a clean, clear container. **DO THIS DAILY.**

If water or contaminants are found in the fuel you drained, **do not** attempt to start the engine. Continue to drain fuel into the container until the fuel is clean.

If large amounts of contamination are found, drain the fuel tank until the lines are clear. Replace the filters. Fill new filters with fresh clean fuel and install.

The Cummins Diesel Engine manual provided with your Patcher contains more detailed information on fuel system maintenance procedures.

Crankcase Oil

Engine crankcase oil level should be checked prior to each day's use of the RA-2000 Patcher. The machine must be parked on a level surface when checking the oil to assure accurate measurements. When checking oil while the engine is warm, wait until the engine has been OFF for at least five minutes. This allows oil to drain back to the crankcase.

The oil dipstick is located between the engine and emulsion tank of the Patcher on the left side of the engine. If the oil measures below the "L" mark on the dipstick, add the proper amount of oil specified in the **Preventive Maintenance Chart** found at the end of this section. After adding oil, recheck the level with the dipstick and make sure it doesn't measure above the "H" mark

Crankcase Oil (cont.)



ATTENTION: DO NOT operate the engine with the oil level below the "L" (Low) mark or above the "H" (High) mark.

Engine crankcase oil and oil filter should be changed after the first 50 hours of service and every 250 hours or 3 months thereafter. Refer to the **Preventive Maintenance Chart** at the end of this section and/or the engine manufacturer's manual for engine oil recommendations.

Air Intake System

The heavy-duty engine air cleaner is mounted on top of the engine panels. A restriction indicator is mounted on the outlet side of the air cleaner assembly housing, near the large inlet tube to the engine (Figure 6-B).

Prior to each day's operation, inspect all air intake system components for damage, cracked hoses, loose clamps etc.

Inspect the restriction indicator several times daily during operation (Figure 6-B). If the red indicator flag on the restriction indicator is visible, the air cleaner element must be removed and replaced.



WARNING: Always wipe the inside of the air cleaner body assembly **before** removing the safety element.

Before replacing any new element on the air filter housing, wipe the inside of the housing with a damp cloth. Reset the restriction indicator. **Be careful** not to introduce any contaminants into the engine intake tube.

When replacing the body assembly or rubber adaptors, torque the T-Clamp bolts to 50 inch pounds.

Do not replace the filter elements until the maintenance interval has been reached or the restriction indicator flag is visible.

Replace the air filter elements every 100 service hours. Replace the safety element every 300

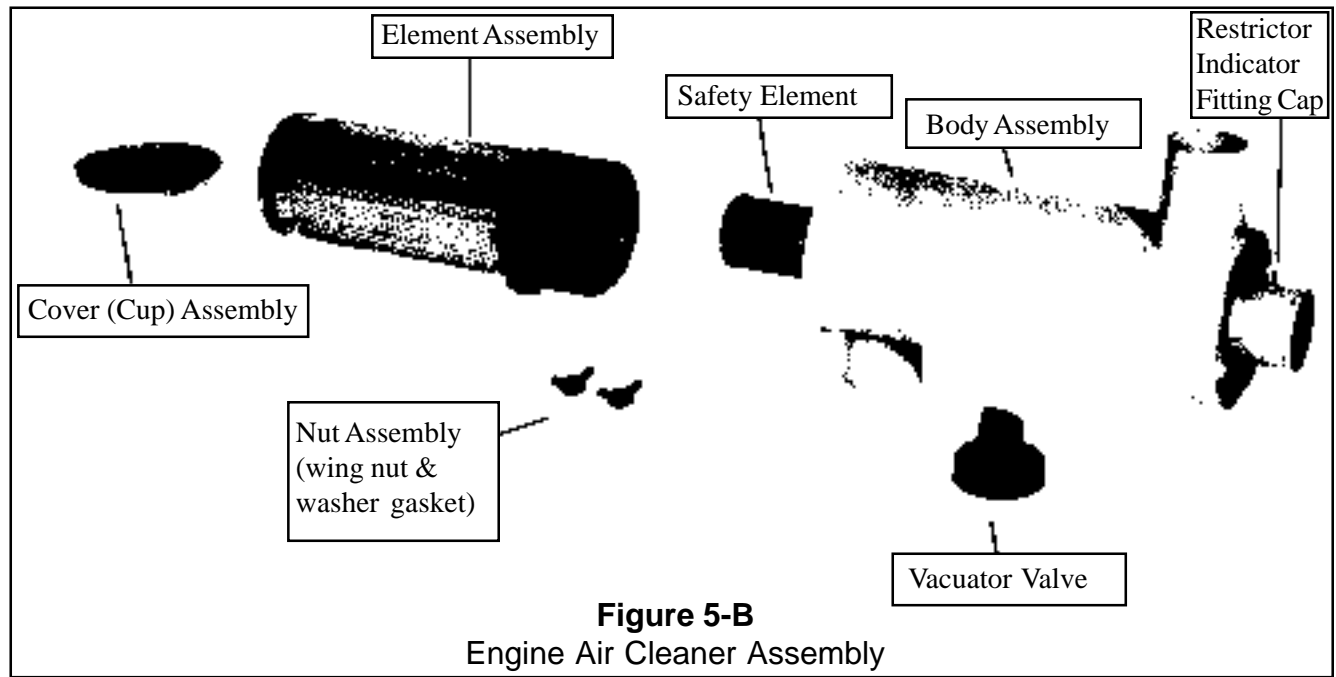

Figure 5-B
Engine Air Cleaner Assembly

Air Intake System (cont.)

service hours. Refer to the **Preventive Maintenance Chart** in this manual for the correct ROSCO part number.

The air inlet hood should not require maintenance or service unless one can see damage.



ATTENTION: DO NOT operate the engine without an air cleaner. Destruction of internal engine components will occur in minutes.

Radiator and Coolant

Check the engine radiator daily for rocks and debris. A partially blocked radiator will reduce the efficiency of the radiator and could cause overheating and premature failure of the engine or its components.

Compressed air can be used to remove rocks or debris from the radiator.

WARNING: Always wear eye protection when using compressed air. Flying debris can cause serious eye injury.



Check radiator coolant level prior to each day's use of the RA-2000 Patcher. The coolant level

Radiator and Coolant (cont.)

when the engine is cold should cover the radiator core. The coolant level when the engine is warm should be at the bottom of the filler tube.



ATTENTION: DO NOT remove the radiator cap when the engine is hot. Escaping coolant can cause serious burns. Add coolant to the radiator **only** when the engine is stopped and fully cooled.

When it is necessary to refill the cooling system, use a mixture of 50% water and 50% ethylene-glycol type antifreeze.

Seasonally, or after every 500 service hours, flush the cooling system. Consult the Cummins Diesel Engine Manufacturer's manual for recommendations on the type of cleaner and procedures to use for this operation.

Generally, any good commercial automotive cooling system cleaning solution can be used. Before replacing the coolant after cleaning, consult the **Preventive Maintenance Chart** in this manual to find the cooling system capacity for your engine. Prepare the coolant as recommended by the engine manufacturer and refill according to the instructions above.

Battery

The RA-2000 Patcher is factory equipped with a battery that is sized to provide efficient starting for the diesel engine on the machine. With proper maintenance, the battery will provide years of trouble-free service.

Starting an engine depends upon good cranking speed. It is important that the battery always be fully charged and that all cables and terminals are cleaned and properly connected to the battery.

Check the level of the battery electrolyte regularly. Add distilled water if necessary, but **do not** overfill. Overfilling can cause poor performance or early failure. A maintenance free battery should rarely require additional electrolyte.

Keep the top of the battery clean. When necessary, wash with a baking soda solution (1 part baking soda to 4 parts water) and rinse with fresh water. **Do not** allow the soda solution to enter the battery cells.

Inspect the cables, clamps and hold-down bracket regularly. Clean and apply a light coating of grease when needed. Replace corroded, damaged parts if necessary.

WARNING: *Always disconnect the battery ground (-) cable first. Always reconnect the positive (+) battery cable first when servicing battery cables and when removing or replacing the battery. Always remove the ground (-) cable when welding on the machine.*



Check the electrical charging system if the battery becomes discharged repeatedly. If the engine is difficult to start or the battery seems weak, clean and check the terminal connections. If the problem continues, the battery should be tested using a battery tester for voltage and current draw.

Battery (cont.)

DANGER: *Explosive gas may remain in and around the battery for several hours after it has been charged. Sparks or flame can ignite this gas causing an explosion which could shatter the battery and cause serious injury. Always shut off the battery charger before disconnecting cables from the battery terminals.*



WARNING: *Always wear eye protection when servicing batteries.*

If the RA-2000 Patcher is to be stored for more than 30 days, remove the battery from the Patcher and store it in a cool, dry place. During storage, keep the battery fully charged and check the level of the electrolyte regularly.

Engine Belts

Check the diesel engine belt for excessive wear, fraying and cracking every 250 service hours. Auxiliary V-belt drives should be inspected every 100 hours. Adjust engine belt(s) as required to provide proper tension. **Consult the Cummins Diesel Engine Manufacturer's manual for correct tension instructions and specifications.**

WARNING: *Always shut OFF engine before adjusting belts. Severe injury can result if belts are adjusted while engine is running.*



When installing new belts, **always** shorten the distance between pulley centers so the belt can be installed without force. **Never** roll the belt over a pulley and **never** pry it with a tool such as a screwdriver. This will damage belts and cause early failure.



WARNING: *Keep belt guards in place at all times. Severe injury can result from contact with turning belts and pulleys.*

ELECTRICAL MAINTENANCE

The RA-2000 Patcher's electrical system is protected from overload damage by fuses. If an electrical component fails to operate, check the fuse panel to be sure that a fuse is not blown. The fuse panel is located on the left side of the instrument panel. See Figure 6-C for location and replacement fuse sizes. Fuses that blow may be replaced, but will continue to blow until the cause of the overload is found and corrected.

The electric throttle, cleanout and aggregate gate are operated by relays. If none of these circuits work, check the 10 amp fuse for the relay power shown in Fig. 6-C. If only one of these systems fails to operate, check the relays. All four relays are interchangeable and can be used to test the faulty circuit.



ATTENTION: Always replace a blown fuse with the same rating as specified. Never replace with a higher amperage rating. Severe wiring damage and fire could result.

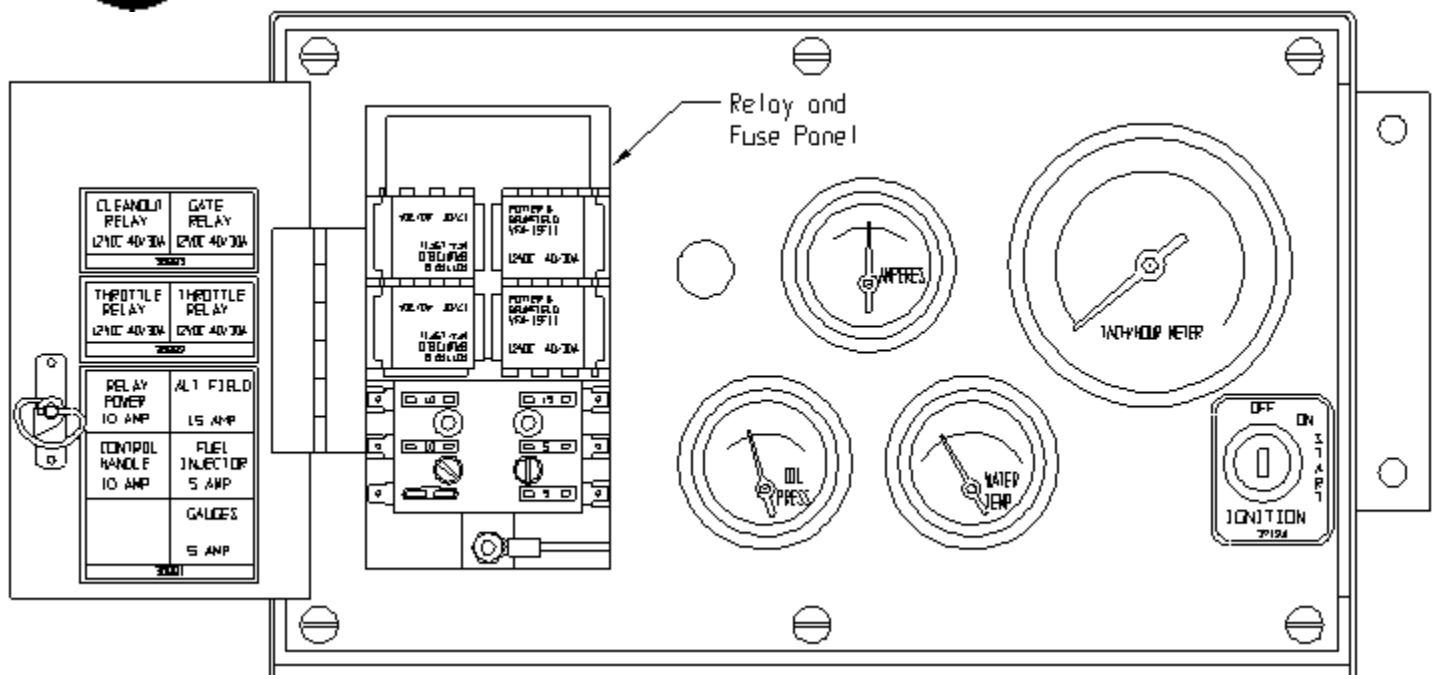

CLEANOUT RELAY 12VDC 40/30A	GATE RELAY 12VDC 40/30A
THROTTLE RELAY 12VDC 40/30A	THROTTLE RELAY 12VDC 40/30A
RELAY POWER 10 AMP	ALT FIELD 15 AMP
CONTROL HANDLE 10 AMP	FUEL INJECTOR 5 AMP
	GAUGES 5 AMP

Figure 5-C
Fuse Panel Location and Fuse Replacement Sizes

PATCHING SYSTEM MAINTENANCE

Air Blower

The RA-2000 Patcher is equipped with a Roots model RA168 high-volume air blower. A Roots manual is available to provide detailed service and maintenance procedures. Figure 6-D illustrates maintenance locations on the blower.

Check the condition of the air blower filter prior to each day's use of the RA-2000 Patcher. Clean or replace the filter as required. Use genuine ROSCO replacement parts when changing this filter. **The complete filter is the element.** Replace the complete filter.



CAUTION: *Before performing maintenance on the blower, remove ignition key and open blower drive shaft guard to prevent accidental operation of the blower. Failure to do so may result in serious injury.*

To check the oil level of the air blower, remove oil overflow plug (E) and the breather (B) from the gear cover on the back side of the air blower. Add oil to the gear case until oil drips out of the oil level hole (E). Consult the **Preventive Maintenance Chart** at the end of this section for oil type and capacity.

ATTENTION: DO NOT overfill air blower gear case. This will cause overheating of the gears and may damage the unit.



Change the oil in the air blower after every 500 hours of operation.



ATTENTION: *Use only the recommended lubricants when changing air blower oil. Failure to do so may damage the air blower and void the warranty.*

To change oil in the air blower:

1. Remove the oil drain plug (A).
2. Drain the used oil and replace the plug.
3. Remove the oil overflow plug (E) and the breather (B). Add fresh oil as required until oil drips out of the oil level hole (E).

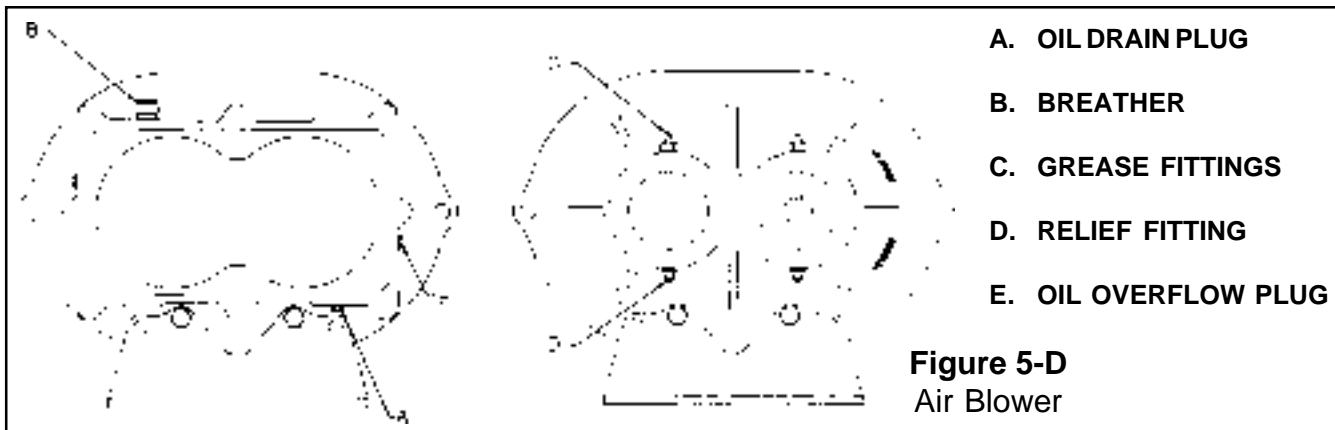

Air Blower (cont.)

4. Consult the **Preventive Maintenance Chart** at the end of this section for the approved oil type and capacity.

Lubricate the bearings on the drive end of the air blower every 100 hours of operation. Lubricate the bearings through grease fittings (C). When greasing, the old grease will be forced out of the relief fittings (E). To prevent damage to seals, these vents must be open at all times.

Check blower coupler for excessive wear or looseness every 40 hours or weekly.

ATTENTION: *Do not operate the blower at less than 1000 RPM's. Running at low RPM's will cause the gearing to vibrate. This will damage the blower. If the vibration can be heard, increase the engine speed.*



Liquid Asphalt Tank

Before filling the liquid asphalt tank, **be sure** the 3-way Valve is in the OFF position. When filling the liquid asphalt tank, allow 2 inches **minimum** free space. This free space will allow room for expansion when the material is heated. An optional filler strainer is available to catch solidified asphalt while filling the tank.



DANGER: *DO NOT smoke while filling the asphalt tank. Fumes could ignite or explode causing severe injury.*

DANGER: *Relieve pressure in the tank by opening the vent valve before opening the hatch.*



The tank level gauge on the rear head of the asphalt tank may freeze up if the asphalt in the tank is allowed to cool. Warm the asphalt with the electric heat elements to free the level gauge and return it to normal position.

Liquid Asphalt Tank (cont.)

If sludge builds up in the bottom of the asphalt tank, remove the drain plug. It is located on the bottom front of the tank. Flush the tank with steam, cleaning fluid or solvent. Because of the wide variety of liquid asphalts that can be used in the RA-2000 Patcher, the asphalt supplier should be consulted to determine the proper solvent for each type of asphalt used.

Thoroughly clean the asphalt tank prior to storing the RA-2000 Patcher for extended periods of time or at least once a year.

NOTE: *Always follow Federal, State and Local requirements when disposing of material after cleaning the asphalt tank.*

Removing Broken Asphalt Emulsion

The following suggestions are for removing broken **asphalt emulsion only**. If you are unsure of the emulsion tank contents, contact an expert for advice.

Asphalt emulsion is considered "broken" when it separates into the components of asphalt and water. The mixture will not flow, and forms layers in the tank. There is usually a watery layer on the top and asphalt below. A crust will sometimes form over the top of the mixture consisting of a hard black surface with lumps in it. Stirring **will not** recombine the components. The emulsion must be removed and properly disposed of.

Causes of Breaking

Asphalt emulsion will break under a variety of conditions. To prevent this from occurring:

1. Do not allow the emulsion to freeze.
2. Do not over heat the emulsion. (185° F, 85° C).
3. Do not mix anionic and cationic grades of emulsions.

Removing Broken Asphalt Emulsion (cont.)

4. Do not over agitate the emulsion.
5. Do not allow the water to evaporate off of the emulsion.
6. Do not blow air through the emulsion.
7. Remove all emulsion from the tank if the Patcher will not be used for a long period of time.

Removing the Broken Asphalt

It is best to take all steps outlined in the operator's manual to prevent the asphalt from breaking, but if it occurs, use the following steps to remove the emulsion from the tank. **Allow plenty of time for this process.** It will take one to two days to complete.

1. Add enough water to **cover** the heating elements. Heat the material to 150° F (67° C). The emulsion should be held at this temperature for four (4) to eight (8) hours. This is necessary to make the emulsion more fluid like.
2. Connect a 5 foot (1.5 m) piece of 1 inch (24.4 mm) diameter hose with a 212° F (100° C) rating to the drain valve on the emulsion tank. The hose must be equipped with a 1 inch (24.4 mm) hose barb fitting (ROSCO part #70036) held on with a worm hose clamp (ROSCO part #33164) on one end. Connect this end to the emulsion tank drain valve.
3. Estimate the number of barrels needed to hold the material and have more than enough on hand. **This is important** because once the draining process has begun, it should be carried out to completion to avoid the material becoming even more difficult to remove.
4. Pressurize the tank to 65 psi. Open the drain valve very slowly while making sure the hose stays in the barrel. Blow the material out into the barrels and watch for leaks. **Handle with extreme care.**

Removing Broken Asphalt Emulsion (cont.)

If the emulsion will not pump out, heat the material to 170° F (76° C) and repeat the procedure.



WARNING: *Wear protective gear for face , hands, body and feet when handling hot material. If hot material touches the skin, flush the area with cool water and get medical attention **immediately.***

Once the tank is empty, close the drain valve and remove the hose. Clean the tank according to the procedure in this manual. If the tank cannot be satisfactorily cleaned using the outlined method, call the supplier of the emulsion or material that is in the tank for suggestions on the proper removal of the material.

DANGER: *Do not use flammable liquids to dissolve the asphalt emulsion. These materials can explode, ignite or cause asphyxiation.*



CHASSIS AND RUNNING GEAR MAINTENANCE

Tires and Wheels

Check tires daily for damage or low pressure. Repair or replace damaged tires to provide safe operation of the RA-2000 Patcher.



DANGER: *Never tow or operate the RA-2000 Patcher with less than four wheels and tires installed and correctly pressurized. Loss of control of the towing vehicle can occur.*

Check tire pressure with an accurate tire pressure gauge prior to each day's operation of the RA-2000 Patcher. All four tires should be inflated to 50 psi when tires are cold.

DANGER: *Never exceed tire manufacturer's maximum recommended inflation pressure as stamped on the tire. Overinflation can cause a tire to explode. This can result in serious injury or death to operator, other traffic or bystanders.*



Protect tires from contact with petroleum products, including liquid asphalt.

Wheel lug nuts should be checked for tightness after the first 50 hours of operation and after every 500 hours of operation. This should be repeated each time a wheel has been loosened to change a tire. Torque wheel lug nuts to 85 ft-lb (115 N-m).

Inspect the wheels for damage prior to each day's use of the RA-2000 Patcher. If a wheel is bent or cracked, replace it prior to further operation.

Hitch and Lighting

When changing towing vehicles, **be sure** the hitch height is adjusted to provide level operation of the RA-2000 Patcher when it is hooked to the towing vehicle. If it is not, unhook the RA-2000 Patcher and adjust the hitch height, making sure that all attaching bolts are tightened to torque specifications listed in the **Bolt Torque Chart** at

Hitch and Lighting (cont.)

the end of this section before reconnecting the towing vehicle. Refer to Section 4 of this manual for **Truck and Hitch Preparation Procedure**.

DANGER: *Always connect safety chains to the towing vehicle before transporting. In case of a hitch failure, the chains will help the operator control the unit until it can come to a stop.*



When connecting the RA-2000 Patcher to the towing vehicle, **always** connect the lighting and brake wiring connector plug to the towing vehicle and verify that all lights and brakes are operational when controlled from the cab of the truck. To test electric brakes, jack up one side of the RA-2000 Patcher and spin a tire while another person steps on the truck brake pedal. The tire should come to an abrupt stop.

If a light or group of lights does not function:

1. Confirm that the lights are working on the towing vehicle.
2. Examine the plug connector. Make sure it is securely fastened. Use a circuit test light to test the plug connector. Check terminals for rust and corrosion.
3. If the light(s) still do not work, remove the lens from the light and inspect the bulb for a broken filament, poor ground etc. Many lighting problems are caused by a faulty bulb or ground. Replace any bulbs that appear damaged or discolored.
4. If the trouble is not located, inspect the wiring harnesses for damage.

If broken wires are found, solder them together and cover with a shrink wrap plastic covering to prevent moisture contamination of the solder joint. If shrink wrap is not available, electrician's tape should be wrapped tightly around the solder joint.

Hitch and Lighting (cont.)

After making repairs to a wiring harness on the RA-2000 Patcher, replace or repair the protective loom which covers the wiring to prevent future damage to the wiring harness. Examine the routing of the harness and make sure it is not subjected to excessive movement which can cause broken wiring. Be sure that all wiring harnesses are securely fastened to the Patcher frame with the correct loom clamps.

Axles and Brakes

Inspect brake pad linings and drums after every 500 hours of operation or **seasonally** since actual mileage on axles may vary on each RA-2000 Patcher. With the wheel and hub removed, inspect brake pad linings for excessive wear and proper operation. Linings should be replaced if they are 1/8 inch thick or less in the **thinnest** spot.

DANGER: Support the chassis **securely** when removing the wheels. **Do not** lie under the RA-2000 Patcher if it is supported only by a jack. Use jack stands on a solid, level surface to stabilize the machine. **Always** block the remaining wheels to prevent rolling when the machine is raised. Death or serious injury could result if one is crushed or becomes pinned under the Patcher.



Before towing the RA-2000 Patcher, **be sure** that the break-away switch is working. Have one person pull the pin from the switch while another listens for a “clunking” sound. This means that the brakes are energized. If no sound is heard, it may be necessary to jack up the wheels, one at a time, and energize the brakes while spinning the wheel by hand. A noticeable drag or abrupt stop should occur immediately after the break-away pin is pulled.

DANGER: **Do not** tow the RA-2000 Patcher if the break-away switch is not functioning properly. The break-away switch is an important safety feature and **must be** in working order **before** the Patcher can be safely towed.



Axles and Brakes (cont.)

Adjust the RA-2000 Patcher's brakes after every 500 hours of service or at the beginning of each season. Information on proper brake adjustment can be found in the brake manufacturer's manual. Only qualified brake technicians should perform brake adjustments.

Axle bearings should be removed, inspected, and repacked with the proper grease after every 500 service hours or seasonally.

To reinstall bearings and hub after lubrication:

1. While rotating the hub slowly to seat the bearings, tighten the spindle nut to approximately 50 ft-lbs (67 N-m).
2. Loosen nut slightly to remove pre-loaded torque. **Do not rotate hub.**
3. Finger tighten nut until snug and place cotter pin in the first nut castellation which lines up with cotter pin hole in spindle.
4. Bend legs on cotter pin to secure the nut. **Be sure** the cotter pin legs do not interfere with the grease cap.
5. Nut should move freely with the only restraint being the cotter pin.

RA-2000 STORAGE

Machine Storage

If the RA-2000 Patcher will be out of service for two or more months, follow these pre-storage procedures to insure a good start-up and prevent down-time when the Patcher is returned to service:

Engine

1. Change oil and filter while the engine is still warm from operation. After changing oil, allow the engine to run for about five minutes to let the oil penetrate all parts.
2. Drain the fuel tank. If available, use a corrosion inhibitor approved for fuel tanks.
3. Set the throttle control to the idle position.
4. Clean the exterior surfaces of the engine. Repair any scratched or chipped painted surfaces. Spread a light film of oil over any non-painted metal surfaces of the engine to prevent rust (except the exhaust system parts).
5. For extended periods of storage, drain the cooling system of all coolant and refill with a mixture of 50% water and 50% glycol anti-freeze.
6. Remove and inspect the air cleaner elements. Replace them as required.
7. Loosen fan and alternator belts to relieve tension. Remove them if desired.
8. Remove and clean battery. Store it in a cool, dry place and keep it fully charged.
9. Seal all openings on the engine with plastic bags and tape.

General Machine

1. **Be sure** there is solvent in all asphalt lines.
2. Drain and clean the asphalt tank.

Machine Storage (cont.)

3. Grease all moving parts and lubrication points.
4. Store the unit where it is protected from adverse weather conditions. Replacement parts, complete assemblies, component repair parts, service kits etc. should also be stored in a dry sheltered area.
5. Clean the Patcher and make a general inspection of all moving parts and components. Repair scratched or chipped painted surfaces. Replace or repair any damaged components on the RA-2000 Patcher.

Removing Machine From Storage

When the RA-2000 Patcher is returned to service:

1. Remove protective coverings from the engine. Unseal openings in the engine and remove any coverings on the electrical systems.
2. Remove the battery from storage. Install it on the Patcher and connect the battery cables.

CAUTION: **Always** disconnect battery ground (-) cable first and **always** re-connect the positive (+) battery cable first when servicing battery cables and when removing or replacing the battery. **Always** remove the ground(-) cable when welding on the machine.



3. Install or tighten fan belt(s) and alternator belt.
4. Fill fuel tank.
5. Drain solvent from asphalt lines.
6. Consult the **Operation Section** of this manual for a pre-start check list.
7. Disconnect the wire to the fuel shut-off solenoid and crank engine for 20 seconds with the

Removing Machine From Storage (cont.)

starter. **Do not start the engine.** Replace the fuel solenoid wire and start the engine.

8. Operate the engine at a slow idle for several minutes. During engine warm-up, check all gauges before operating the Patcher and placing a load on the engine.

Positive Displacement Air Blower Storage Procedure

If the RA-2000 Patcher will be out of service for two months or longer, the following steps should be taken for corrosion protection:

1. Coat the exposed rod of the cylinder and the gearbox with Nox-Rust No. VC110* or an equivalent. Repeat at the end of each season or as conditions require. To remove VC110 from the cylinder before startup, spray a fine mist of petroleum solvent (such as LPS Lubricant) through the blower while it is running at a slow speed. **Be sure** the inlet and discharge are open.



WARNING: *Petroleum solvents are flammable and explosive if confined. Avoid all sparks, flame or hot objects while using petroleum solvents. Death or serious injury will result from explosion.*

2. Fill the drive end bearing cavities with grease.
3. Paint the shaft extensions, inlet and discharge flanges and all other exposed surfaces with Nox-Rust X-110* or an equivalent.
4. Seal the inlet, discharge and all vent openings with tape. Do not leave the unit set in place, piped to the system for extended periods of time.
5. Do not expose units to excessive vibration

Positive Displacement Air Blower Storage Procedure (cont)

during storage. If the unit is to be stored outdoors, cover it with a tarpaulin.

6. Rotate the drive shaft three or four revolutions every two weeks.

Removing the Positive Displacement Air Blower From Storage

Prior to startup:

1. Remove the flange covers from both the inlet and discharge vents.
2. Inspect the internal components to be sure they did not rust during storage.
3. Check all internal clearances.
4. Remove the gearbox and inspect the gear teeth for rust.

Before re-assembling the blower to the unit:

1. Remove plugs, covers or seals from blower inlet and discharge connections. Inspect the interior for any dirt or other foreign material. If necessary, wash the cylinder, headplates and impeller with a petroleum solvent such as DuPont Triclene D.
2. Wash the blower.
3. Turn the drive shaft by hand to ensure that the impeller turns freely at all points. The same petroleum solvent may be used to clean anti-rust compounds from the drive shaft extensions.
4. Replug the inlet and discharge connections until ready to reinstall the blower to the air piping.

Removing the Positive Displacement Air Blower From Storage *(cont)*

The corrosion inhibitor that was used prior to storage does not need to be removed. It will vaporize during operation.



WARNING: Keep hands, feet, hair and clothing away from blower inlet, discharge ports and other rotating parts.

* Nox-Rust Products may be purchased from:
Daubert Chemical, Inc.
4700 S. Central Ave.
Chicago, IL 60638
Phone:(708) 496-7350 Fax:(708) 496-7367

LUBRICATION

After the Patcher has been stored for a long period of time, replace the grease in the bearings. Remove the relief fittings. Flush out the old grease with kerosene or #10 lubricating oil. Drain thoroughly and replace with fresh bearing grease, using a hand operated grease gun. Reinstall the grease relief fittings.

The following chart shows the recommended schedule for greasing the drive end bearings, based on the operating hours per day and RPM used. You may need to grease more often depending on the operating temperature of the grease and unusual operating conditions.

Speed in RPMs	Operating hours per day		
	8	16	24
	Greasing Intervals in Weeks		
750 - 1000	7	4	2
1000 - 1500	5	2	1
1500 - 2000	4	2	1
2000 - 2350	3	1	1

Air Blower Lubrication Chart
Based on normal operating RPMs and Hours Per Day the unit is in use.

PREVENTIVE MAINTENANCE CHART

Identifying Codes: I = Inspect L = Lubricate R = Replace
 A = Adjust S = Service

ITEM	MAINTENANCE INTERVAL					CAPACITY	PART NUMBER	TYPE
	Daily	50 Hours	100 Hours	250 Hours	500 Hours			
Air Blower Bearings		L		L			Bearing Kit 35858-13	No. 2 Non-Corrosive Grease
Air Blower Driveshaft	I		L					Multi-Service Grease
Air Blower Filter	I	I	S	S	R		36531-1	Dry Filter
Air Blower Oil	I				R	1pt. (.47 L)	36485-01 (QT.)	AEON Blower Lubricant
Axle Bearings			I		I/R			Wheel Bearing Grease
Axle Brake Linings			I/A		A/R		Shoe & Lining Kit 33515-05	
Boom Hanger Bearings			L		L			Multi-Service Grease
Boom Spindle Bearings					L/R			Multi-Service Grease
Engine Air Filters	I	I	S	S	R		Primary> 37757-01 Safety>37757-02	Dry Cartridge Filters
Engine Fan Belt	I		I/A	I/A			33962-1	V-Rib Belt
Engine Coolant	I				R	18 qts. (17.03 L)	90599	50/50 Antifreeze
Engine Fuel Filters	S				R		Primary>72078 Secnd>34883 In-line >33291	Cartridge Filters In-line Filter
Engine Oil	I	R		R		11.5 qts. (10.88L)	90384	SAE 15W40 CC/CD
Engine Oil Filter		R		R			34881	Cartridge Filter

BOLT TORQUE CHART

The table below gives correct torque values for various **NON-LUBRICATED** bolts. **DO NOT** lubricate bolts unless otherwise specified in this manual. Check tightness of bolts periodically, using this table as a guide. **ALWAYS** replace hardware with an equal strength fastener. When using locking fasteners, increase torque values by 5%.

BOLT IDENTIFICATION BY HEAD MARKINGS:

FT-LB = Foot Pound
N-M = Newton Meter



BOLT SIZE	ENGLISH				METRIC			
	GRADE 5		GRADE 8		CLASS 8.8		CLASS 10.9	
	FT-LB	N-M	FT-LB	N-M	FT-LB	N-M	FT-LB	N-M
M6	-	-	-	-	7	10	11	15
1/4	9	12	12	17	-	-	-	-
5/16	19	25	27	36	-	-	-	-
M8	-	-	-	-	18	25	26	35
3/8	33	45	45	63	-	-	-	-
M10	-	-	-	-	37	50	52	70
7/16	53	72	75	100	-	-	-	-
M12	-	-	-	-	66	90	92	125
1/2	80	110	115	155	-	-	-	-
M14	-	-	-	-	103	140	148	200
9/16	115	155	165	220	-	-	-	-
5/8	160	215	220	305	-	-	-	-
M16	-	-	-	-	166	225	229	310
3/4	290	390	400	540	-	-	-	-
M20	-	-	-	-	321	435	450	610
7/8	420	570	650	880	-	-	-	-
M24	-	-	-	-	553	750	774	1050
1	630	850	970	1320	-	-	-	-
M30	-	-	-	-	1103	1495	1550	2100

TROUBLE SHOOTING SECTION

<i>No Aggregate Flow</i> -----	6.2 - 6.3
<i>Poor or Uneven Aggregate Flow</i> -----	6.3 - 6.4
<i>Dusty Delivery of Aggregate</i> -----	6.4
<i>No Liquid Asphalt at Nozzle</i> -----	6.4
<i>Poor or Uneven Asphalt Flow</i> -----	6.5
<i>No Solvent for Cleanout</i> -----	6.5
<i>Low/No Air From Blower</i> -----	6.6
<i>Heat System not Working</i> -----	6.6
<i>Engine Coolant System Not Heating Asphalt</i> -----	6.6 - 6.7
<i>Control Panel Inoperative</i> -----	6.7

TROUBLE SHOOTING

General

The following Trouble-Shooting information includes some problems and possible solutions that an operator may encounter during the course of operating the RA-2000 Patcher. Unless otherwise noted, the problems listed here are those which an operator can diagnose and repair. See an Authorized Rosco Dealer/Distributor for diagnosis and repair of problems not listed. For specific engine and hydraulic problems not covered by this guide, please refer to the other guides for major components that you received with the unit.



DO NOT ATTEMPT TO SERVICE OR REPAIR MAJOR COMPONENTS, such as the blower, hydraulic cylinders or pressure control equipment, unless authorized to do so by your Rosco Dealer/Distributor. **Any Unauthorized Repair Will Void The Warranty.**

When a problem occurs, don't overlook the simple causes. A malfunction could be caused by something as simple as a valve that is not fully open or closed. After a mechanical failure has been corrected, be sure to locate and correct the cause of the problem.

TROUBLE	POSSIBLE CAUSE	REMEDY
<p>No Aggregate Flow (Be sure there is aggregate in the tank.)</p>	<ol style="list-style-type: none"> 1. Delivery hose plugged. The machine may have been driven with the aggregate tank slide gate open allowing rock into the hose. Be sure Rock Flow Switch is OFF when travelling. 2. Valve not activated to open slide gate. 3. Insufficient air volume. 	<ol style="list-style-type: none"> 1a. Open at coupling on boom and clean out. 1b. Disconnect hose at slide gate, remove from hangers and clean out. 1c. Increase engine RPM while monitoring blower pressure. Do not exceed 7 psi. 2. Activate valve 3a. Check blower RPM (should be 1100-1300). 3b. Check & clean blower air filter. 3c. Check for air leaks in discharge piping and at aggregate hopper lid, slide gate, hoses.

TROUBLE	POSSIBLE CAUSE	REMEDY
<p>No Aggregate Flow (cont)</p>	<p>4. Slide gate jammed shut.</p> <p>5. Rock frozen in hopper.</p> <p>6. Build up of fines on inside walls of hose.</p> <p>7. Aggregate gate opens and closes slowly or not at all.</p>	<p>4a. If frozen, use heat to thaw. If jam is caused by limestone buildup, spray with high pressure water to clean.</p> <p>5. Warm or thaw out.</p> <p>6a. Use clean aggregate.</p> <p>6b. Use rubber hammer to tap on outside of hose to loosen build up.</p> <p>7. Air breather on the solenoid valve is plugged and will not let air out of gate cylinder. Clean or replace the breather.</p>
<p>Poor or Uneven Aggregate Flow</p>	<p>1. Aggregate is wet and/or bridging.</p> <p>2. Delivery hose needs cleaning.</p> <p>3. Insufficient air volume.</p>	<p>1. Use clean, dry rock.</p> <p>2a. Remove and clean hose. Flush nozzle.</p> <p>2b. Flush delivery system with water.</p> <p>3a. Check blower RPM (should be 1100-1300).</p> <p>3b. Check and clean blower air filter.</p> <p>3c. Check for air leaks in discharge piping and at aggregate hopper lid, slide gate and hoses.</p>

TROUBLE	POSSIBLE CAUSE	REMEDY
<p>Poor or Uneven Aggregate Flow (cont)</p>	<p>4. Aggregate gate opens and closes slowly or not at all.</p>	<p>4. Air breather on the solenoid valve is plugged and will not let air out of gate cylinder. Clean or replace the breather.</p>
<p>Dusty Delivery Of Aggregate</p>	<p>1. Dry, dusty material.</p>	<p>1a. Dampen rock in truck. 1b. Replace with new aggregate material.</p>
<p>No Liquid Asphalt / Emulsion Available at Nozzle</p>	<p>1. 3-way valve on asphalt tank is OFF or in "Flush" position. 2. Low air pressure. 3. Line, valve or nozzles clogged. 4. Separated emulsion. 5. Low tank level. 6. Valves on discharge nozzle in OFF position. 7. Asphalt cement or cut back asphalt has been used by mistake.</p>	<p>1. Select "Asphalt" position. 2. Check air lines, valves and gauges. 3. Check and clean or replace. 4. Drain tank and fill with new emulsion. 5. Fill tank.  Relieve All Pressure Before Opening Load Hatch. 6. Open valves. 7. Consult the factory for clean out procedure.</p>

TROUBLE	POSSIBLE CAUSE	REMEDY
Poor Or Uneven Asphalt / Emulsion Flow	<ol style="list-style-type: none"> 1. Separated emulsion. 2. Air pressure too low. (below 25psi) 3. Asphalt / Emulsion too cool. 4. Outside temperature too cool for type of material being used. 5. Nozzles plugged or too large. 6. Air pressure too high. (above 60psi) 	<ol style="list-style-type: none"> 1. Drain and replace with new material. 2. Check air lines, valves and gauges. Increase air pressure to 35 - 40psi. 3. Heat to proper spray temperature for material. 4. Consult local supplier for recommendations. 5. Unplug or use smaller nozzles. 6. Decrease air pressure to 35 to 40psi.
No Solvent For Clean Out	<ol style="list-style-type: none"> 1. No solvent in tank. 2. 3-way valve on asphalt tank is in wrong position. 3. Solvent pump won't prime. 4. Valves on nozzle are closed. 5. Solvent pressure is too low. 	<ol style="list-style-type: none"> 1. Fill tank with solvent. 2. Select "Flush" position. 3. Bleed air out of the pump by opening the ball valve. 4. Open valves. 5. Set pressure to 150 psi.

TROUBLE	POSSIBLE CAUSE	REMEDY
<p>Low/No Air From Blower</p>	<ol style="list-style-type: none"> 1. Plugged air cleaner. 2. Plugged discharge hose or piping. 	<ol style="list-style-type: none"> 1. Clean or replace element. 2. Clean out hose or piping.
<p>120-volt (240-volt for European models) Heat System Not Working</p>	<ol style="list-style-type: none"> 1. Tripped circuit breakers or blown fuse. 2. Thermostat not set to desired temperature. 3. Faulty wiring. 4. Electric element(s) burned out. 	<ol style="list-style-type: none"> 1. Reset or replace. 2. Set temperature or thermostat 3a. Check wiring with volt/ohmmeter  <p>Use Extreme Caution When Checking Circuits - May Cause Death.</p> 3b. Test for continuity with power disconnected. 3c. Be sure circuit breaker is rated properly for this use. 4. Replace element(s).
<p>Engine Coolant System Not Heating Asphalt / Emulsion to High Enough Temperature</p>	<ol style="list-style-type: none"> 1. Desired asphalt temperature is above 180° F (82° C). 2. Faulty engine thermostat. 	<ol style="list-style-type: none"> 1. Coolant heating system was not intended to heat Asphalts / Emulsions above 180° F (82° C). 150° F (66° C) is normal emulsion temperature. 2. Replace with 195° F (91° C) or higher thermostat.

TROUBLE	POSSIBLE CAUSE	REMEDY
Engine Coolant System Not Heating Asphalt / Emulsion to High Enough Temperature (cont)	3. Pinched or plugged circulation hose.	3. Inspect, clean or replace.
Control Panel Inoperative	1. Tripped or blown fuse. 2. Wire loose.	1. Reset or replace. 2. Check all wiring.

RDSCO

A LeeBoy Company

RA-2000 PATCHER

PARTS CATALOG

MANUAL PART NO. 38022-02

EFFECTIVE SERIAL NO. 35870 and up

REVISED 2/15/99

NOTE: It is the responsibility of the customer or user's management to train, educate and supervise the employee in the proper operation and maintenance of this equipment.

688 North Highway 16
Denver, North Carolina
www.LeeBoy.com
Phone: 704-966-3300

PARTS SECTION

Decal Group	7.2 - 7.7
Engine Group	7.8 - 7.11
Radiator Group	7.12
Throttle Group	7.13
Blower Group	7.14 - 7.15
Air Intake System	7.16 - 7.17
Exhaust Group and Filter Kit	7.18 - 7.19
Instrument Panel Group	7.20 - 7.23
Instrument Wiring Group	7.24 - 7.25
Electrical Group, 120 Volt	7.26 - 7.27
Emulsion Tank Group	7.28 - 7.29
Aggregate Hopper Group	7.30 - 7.33
Tail Gate Group	7.34 - 7.35
Frame Group	7.36 - 7.37
Boom and Hose Group	7.38 - 7.39
Nozzle Group	7.40 - 7.41
Boom Control Group	7.42 - 7.43
Boom Sub-Assembly	7.44 - 7.45
Fuel and Flush Group	7.46 - 7.47
Compressed Air Group	7.48 - 7.49
Engine Cover Assembly	7.50 - 7.53
Final Group	7.54 - 7.57
Strobe Light Group	7.58
Lunette Eye	7.58
Optional Equipment	7.60 - 7.65
Crack Filling Group	7.60 - 7.61
Handspray Gun Assembly	7.60 - 7.61
Fill Strainer	7.62 - 7.63
Ball Hitch	7.64 - 7.65
Arrow Board Group	7.66 - 7.67
Electrical Group, 240 Volt	7.68 - 7.69
Alphabetical Parts Index	7.71 - 7.77
Schematics	End of section

DECAL GROUP

ROSCO RA-2000 Patcher

STANDARD EQUIPMENT

REF: 25667

REV: B

ITEM	PART NO.	QTY.	DESCRIPTION
1	30553	1.00	DECAL,SOLVENT TANK
2	38097	1.00	DECAL,RA2000
3	35355	1.00	PLATE,SERIAL NUMBER,ROSCO
4	35689	1.00	DECAL PLATE,WRN,HOT MAT'L HAZ
5	35745	4.50	DECAL,STRIPING,3 BAND BLACK
6	35851	4.00	RIVET,BLIND,AL,.188,.020-.125
7	35870	2.00	DECAL,DANGER,FAN BLADES
8	35943	2.00	DECAL,WARNING,GUARDS
9	35945	1.00	DECAL,CAUTION,HOT SURFACE
10	35946	1.00	DECAL,CAUTION,HEARING PROTECT
11	36202	2.00	DECAL,WARNING,KEEP CLEAN
12	36472	1.00	DECAL,THE PATCHER
13	38099	1.00	DECAL,CAUTION,RA2000
14	37096	2.00	DECAL,DANGER,HIGH VOLTAGE
15	37651	1.00	DECAL,TRAILER MANUFACTUER

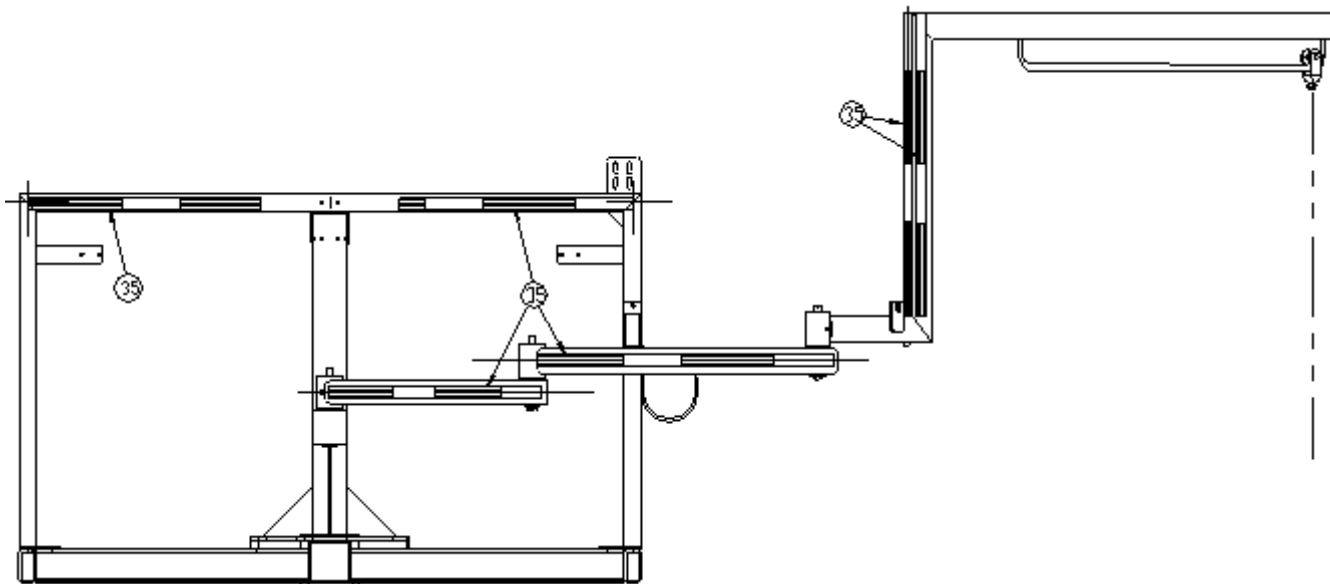

Boom

Other Views of This Group Shown on Following Pages...

Top View

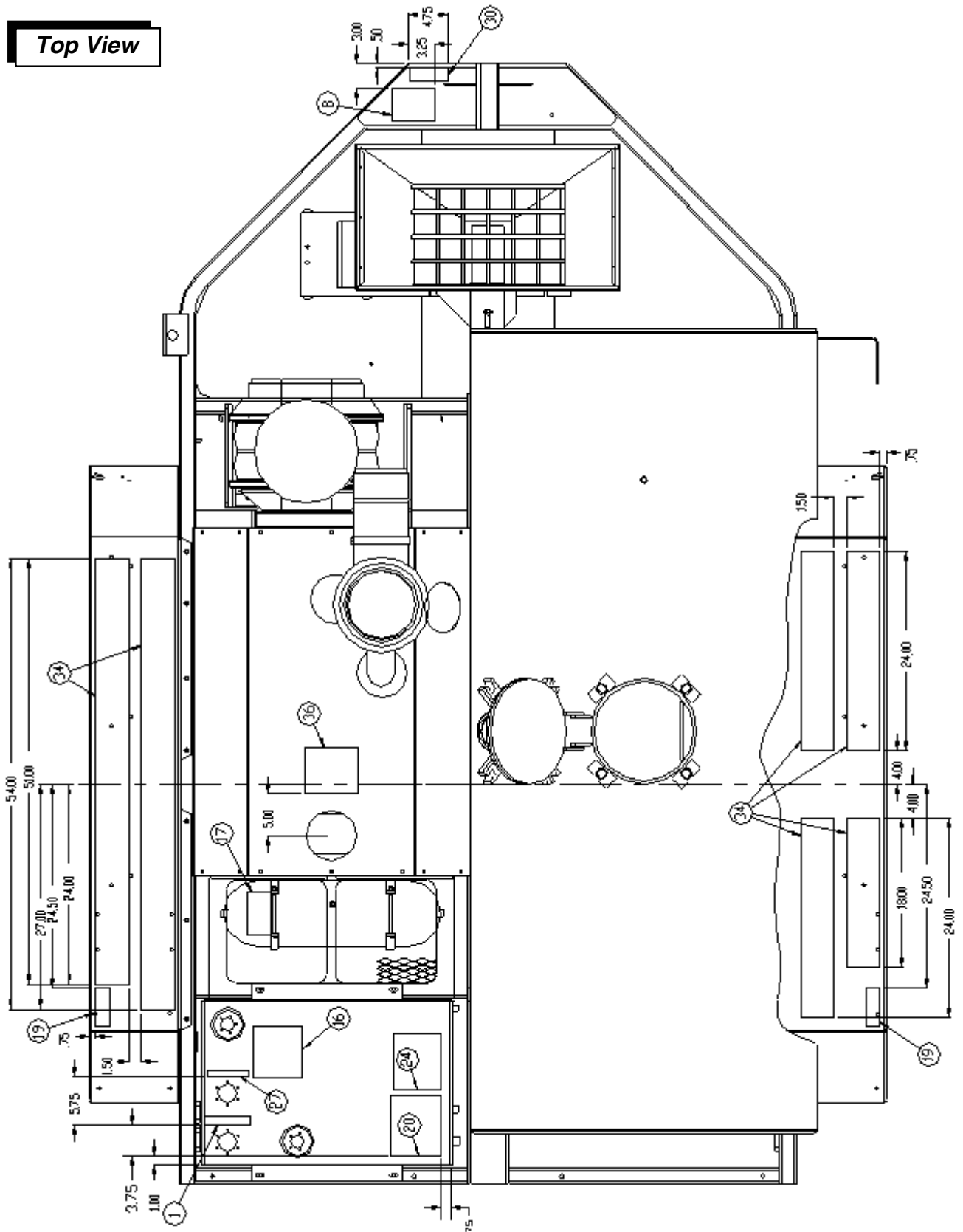

DECAL GROUP**ROSCO RA-2000 Patcher**

STANDARD EQUIPMENT

REF: 25667

REV: B

ITEM	PART NO.	QTY.	DESCRIPTION
16	37098	2.00	DECAL,DANGER,FIRE/EXPLOSION
17	37123	2.00	DECAL,WARNING,UNDER PRESSURE
18	37133	8.00	RIVET,BLIND,AL,.125,.126-.187
19	37169	2.00	DECAL,CAUTION,TIRE PRESSURE
20	37180	1.00	DECAL,WARNING,BOOM,RA200
21	37243	1.00	DECAL,WARNING,ENGINE EXHAUST
22	37435	1.00	DECAL,DANGER,USE GFI CIRCUIT
23	38053	1.00	DECAL,EMULSION
24	38098	1.00	DECAL,ATTENTION,ROOTS BLOWER
25	53495	1.00	DECAL,GENERAL INSTRUCTION
26	72062	1.00	DECAL,DIESEL POWER,CUMMINS
27	72589	1.00	DECAL,DIESEL FUEL
28	72627	1.00	DECAL,WARNING,BATTERY INJURY
29	853521158	2.00	INDICATOR,AIR CLEANER
30	D13	1.00	DECAL,CAUTION,TOWING CHAINS
31	D48	1.00	DECAL,ROSCO LOGO,SMALL,BLACK
32	D50	2.00	DECAL,ROSCO LOGO,MEDIUM,BLACK
33	37129	1.00	DECAL,CAUTION,PROTECTIVE GEAR
34	004684102	12.00	STRIP,ABRASIVE,4"X60'ROLL,BLK
35	38077	24.00	REFLECTIVE TAPE,1.50,RED/WHITE
36	72590	1.00	DECAL,HOT FLUID HAZARD,WARNING

***Other Views of This
Group Shown on
Following Pages...***

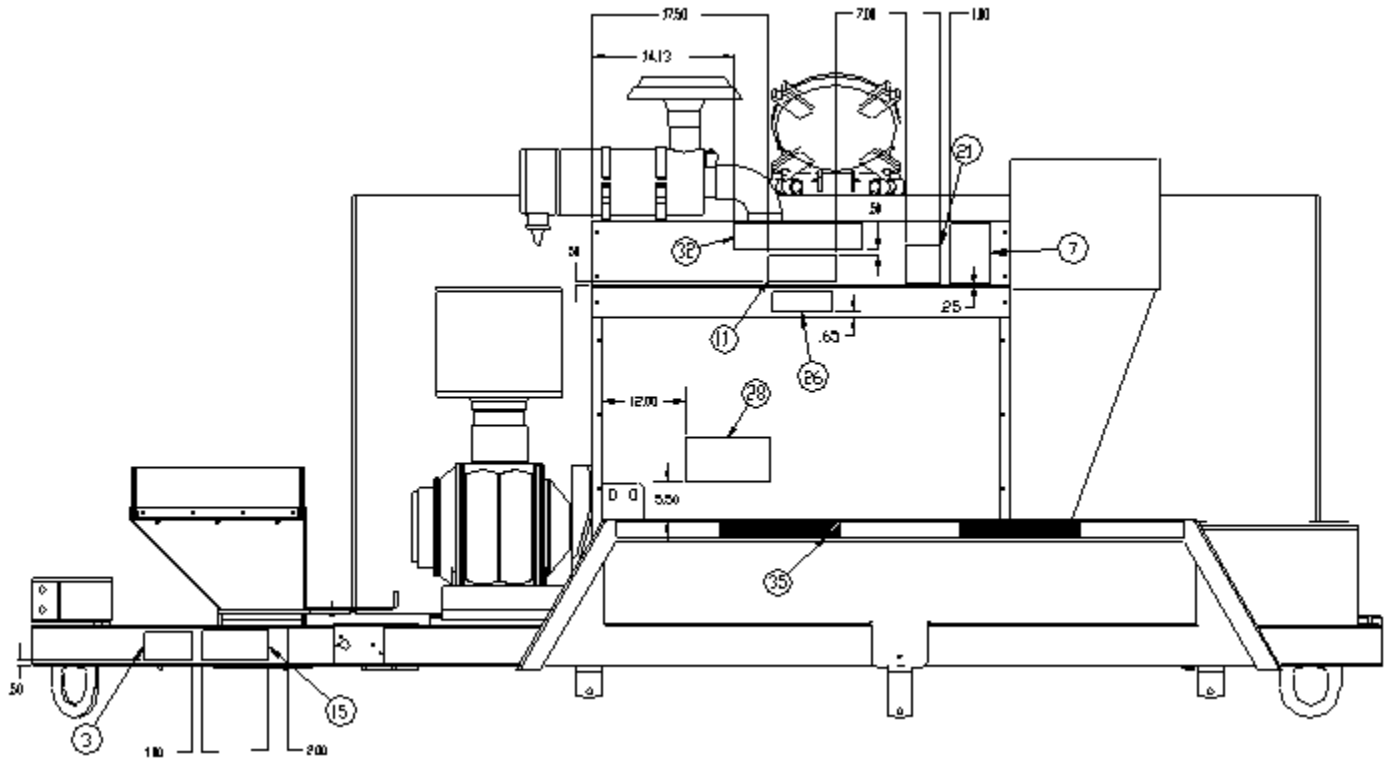

Left Side View

Right Side View

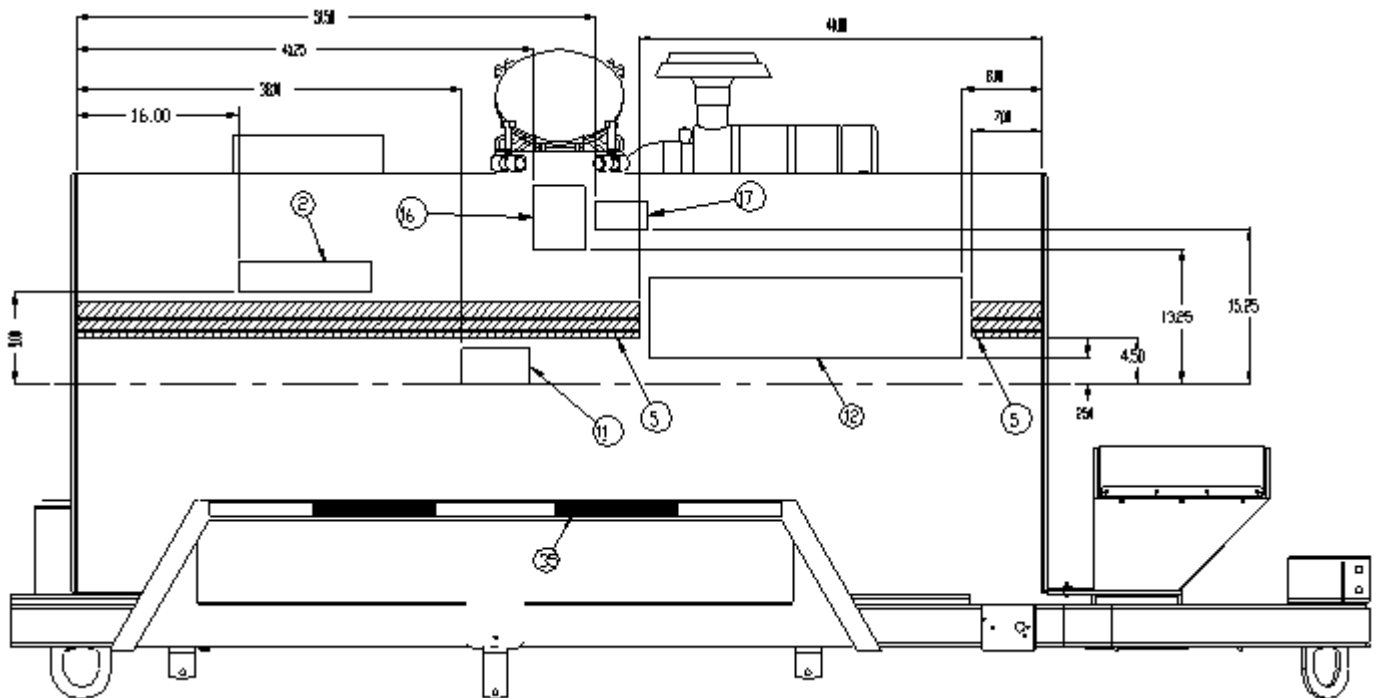

DECAL GROUP

STANDARD EQUIPMENT

ROSCO RA-2000 Patcher

REF: 25667

REV: B

ITEM	PART NO.	QTY.	DESCRIPTION
------	----------	------	-------------

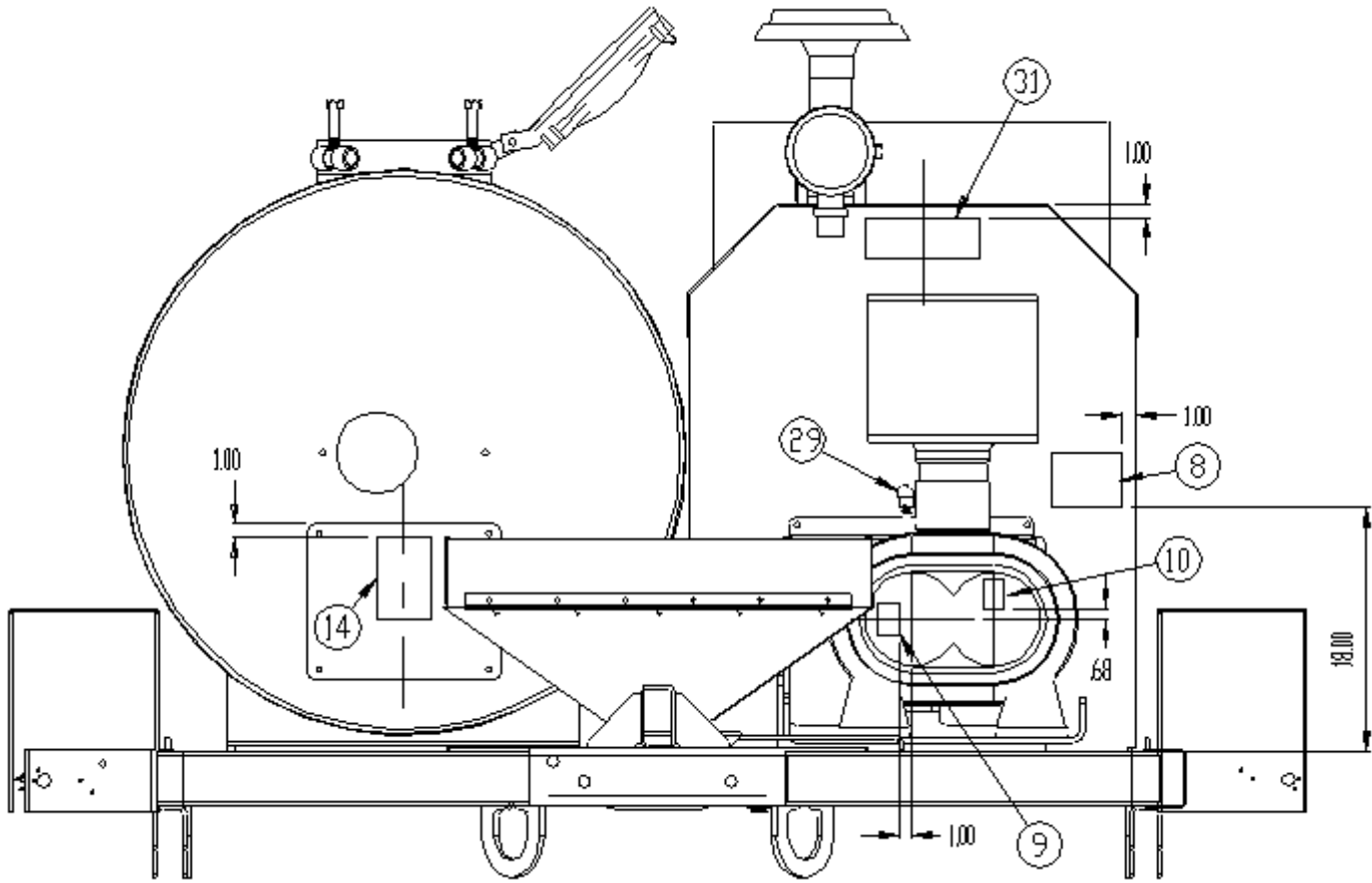

Front View

Other Views of This Group Shown on Previous Pages...

See Supporting Text On Previous Pages

Rear View

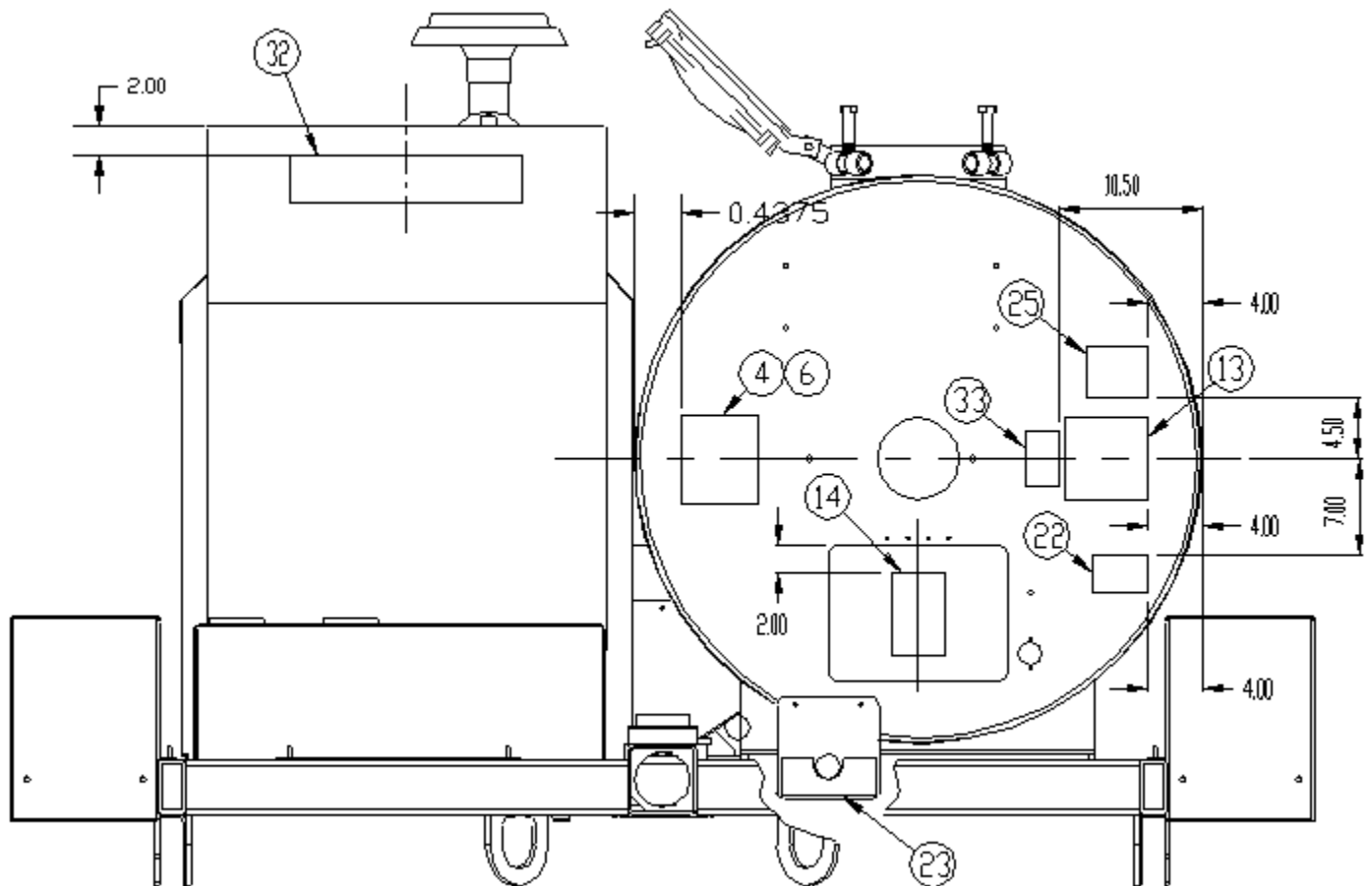

ENGINE GROUP

ROSCO RA-2000 Patcher

STANDARD EQUIPMENT

REF: 27209

REV: A

ITEM	PART NO.	QTY.	DESCRIPTION
2	25419	1.00	RADIATOR GROUP,RA2000
3	25420	1.00	BLOWER GROUP,RA2000
4	27210	1.00	THROTTLE GROUP,RA2000,ROTARY
5	27062	1.00	AIR INTAKE SYSTEM,RA2000,FRANCE
6	35571	1.00	SWITCH,PRESSURE,02 MP,NO & NC
7	25437	1.00	EXHAUST GROUP,RA2000
8	36073	6.00	WASHER,3.25ODx.80IDx.188T
10	37045	3.00	MOUNT,RUBBER,TUBE FORM,400 LB
11	33328	1.00	FITT,90 08MP-08HB,CRIMPED
12	X427	1.00	FITT,STR 08MP-08HB,CRIMPED
13	80141	10.00	WASHER,TYPE A PLAIN,.312
14	80147	4.00	WASHER,TYPE A PLAIN,.750
15	80357	2.00	NUT,FLEXLOC,.750-10,FULL,LT
17	80980	2.00	CSHH,.750-10X4.00,GR5
18	81105	1.00	CSHH,M16X2.0X80,CL10.9
19	38110	1.00	ENGINE,CUMMINS,4B3.9,RA2000
21	80351	4.00	NUT,FLEXLOC,.312-18,FULL,LT
22	80697	1.00	WASHER,SAE PLAIN,.625
23	80166	1.00	WASHER,SPLIT LOCK,.625
24	21198	1.00	BRACKET,SOLENOID,CUMMINS 4B3.9
26	35363	1.00	SENDER,PRESS,OIL,02 MP
27	35367	1.00	SENDER,TEMP GAUGE,08 MP
28	36018	1.00	CABLE,BATTERY,NEG,14X0GA
29	36031	1.00	CABLE,BATTERY,POS,16X0GA
30	5804	1.00	CABLE,BATTERY,2 LUG,0GAX13
31	70437	1.00	BATTERY BOOT,POS(RED)
32	72313	1.00	HOLD DOWN,BATTERY
33	80142	10.00	WASHER,TYPE A PLAIN,.375
34	80221	2.00	CSHH,.375-16X1.00,GR5
35	80192	2.00	CSHH,.250-20X.75,GR5
36	80350	2.00	NUT,FLEXLOC,.250-20,FULL,LT
37	80393	2.00	CSHH,.375-16X9.50,GR5
38	80478	3.00	WASHER,SPLIT LOCK,M10
39	80482	3.00	CSHH,M12X1.25X25,CL8.8
40	80484	11.00	WASHER,SPLIT LOCK,M12

***Other Views of This
Group Shown on
Following Pages...***

ENGINE GROUP

ROSCO RA-2000 Patcher

STANDARD EQUIPMENT

REF: 27208

REV: A

ITEM	PART NO.	QTY.	DESCRIPTION
41	81007	1.00	NUT,HEX,M5X.80
42	81008	1.00	NUT,HEX,M10X1.50
43	81043	1.00	WASHER,SPLIT LOCK,M5
44	X108	1.00	SOLENOID,INTERMIT DUTY,12VDC
45	33146-6	1.00	BATTERY,12V,950 CRK AMPS
47	27348	1.00	HARNESS,ENG,RA2000,FRANCE,ROT
48	37024	1.00	FITT,90 08MP-08FP
49	36066	1.00	FITT,TEE 02MP-02FP-02FP,STL
50	16959	1.00	HARNESS,WIRE,JUMPER,ALTERNATOR
51	80140	2.00	WASHER,TYPE A PLAIN,.250
52	80144	8.00	WASHER,TYPE A PLAIN,.500
53	80514	8.00	CSHH,M12X1.75X35,CL8.8
54	80352	4.00	NUT,FLEXLOC,.375-16,FULL,LT
55	80226	4.00	CSHH,.375-16X1.50,GR5
57	19823	1.00	HARNESS,WIRING,ALTERNATOR

***Other Views
of This
Group
Shown on
Previous
Pages...***

RADIATOR GROUP

STANDARD EQUIPMENT

ROSCO RA-2000 Patcher

REF: 25419

REV: B

ITEM	PART NO.	QTY.	DESCRIPTION
1	21987	2.00	BRKT,RADIATOR MOUNT
2	22259	4.00	BRACE,ENGINE PANEL
3	33169	2.00	CLAMP,HOSE,1.31-2.25,WORM #28
4	33437	2.00	CLAMP,HOSE,2.06-3.00,WORM,#40
5	36395	1.00	HOSE,RAD,1.75 ID,90 DEG
6	37029	1.00	RADIATOR,CUMMINS 4B3.9
7	80141	8.00	WASHER,TYPE A PLAIN,.312
8	80161	8.00	WASHER,SPLIT LOCK,.312
9	80208	8.00	CSHH,.312-18X1.00,GR5
10	80226	8.00	CSHH,.375-16X1.50,GR5
11	80352	8.00	NUT,FLEXLOC,.375-16,FULL,LT
12	80142	8.00	WASHER,TYPE A PLAIN,.375
13	25755	1.00	FAN GUARD W/M

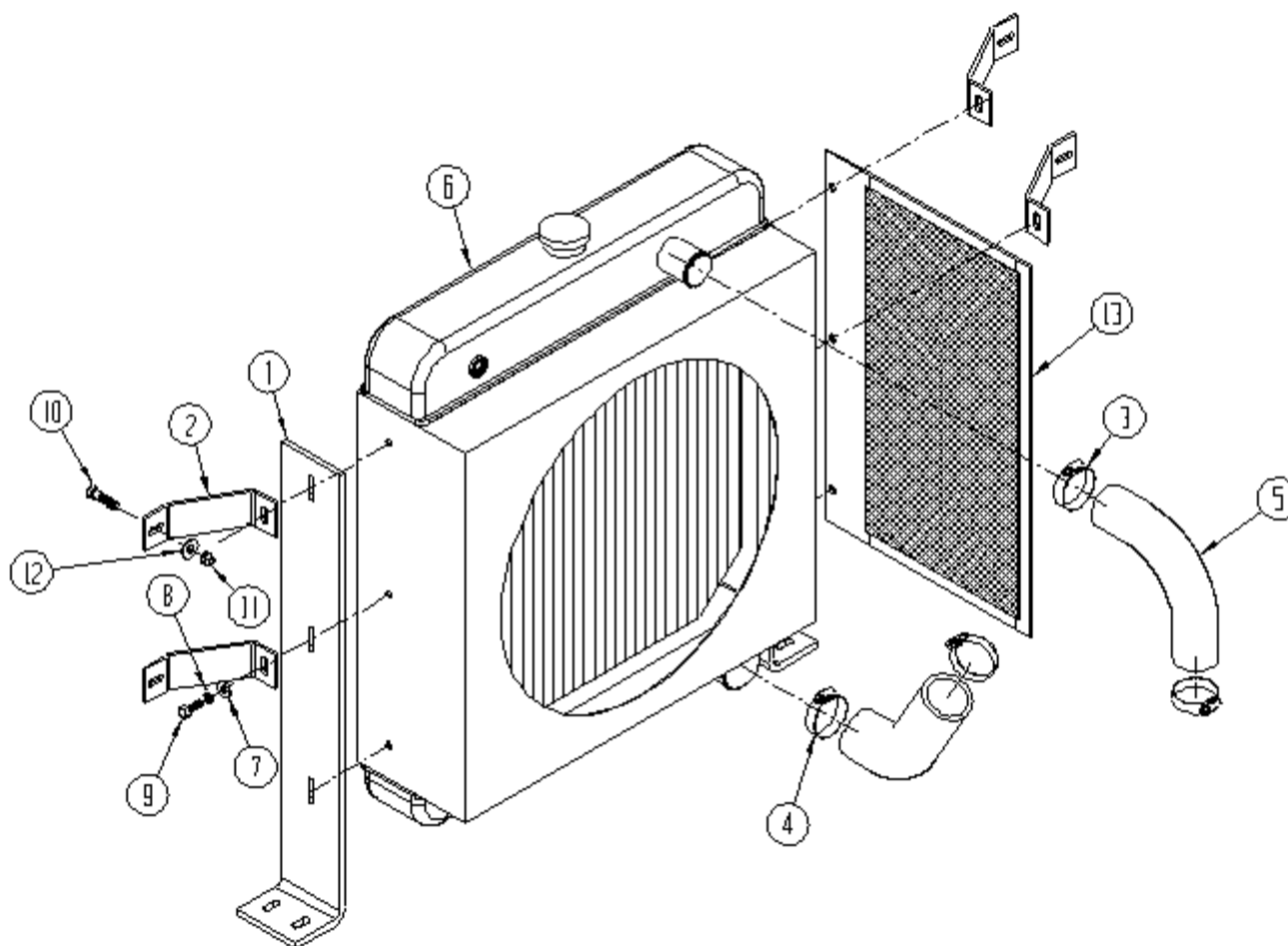

ITEM	PART NO.	QTY.	DESCRIPTION
1	23252	1.00	ACTUATOR, THROTTLE/EMULSION
2	26168	1.00	BRACKET, THROTTLE CABLE
3	27345	1.00	TUBE, RND, .375X18 GA, DOM X .625
4	27346	1.00	LEVER, THROTTLE
5	80036	1.00	NUT, HEX, .250-20
6	80140	1.00	WASHER, TYPE A PLAIN, .250
7	80192	4.00	CSHH, .250-20X.75, GR5
8	80194	1.00	CSHH, .250-20X1.50, GR5
9	80196	1.00	CSHH, .250-20X2.00, GR5
10	80350	6.00	NUT, FLEXLOC, .250-20, FULL, LT

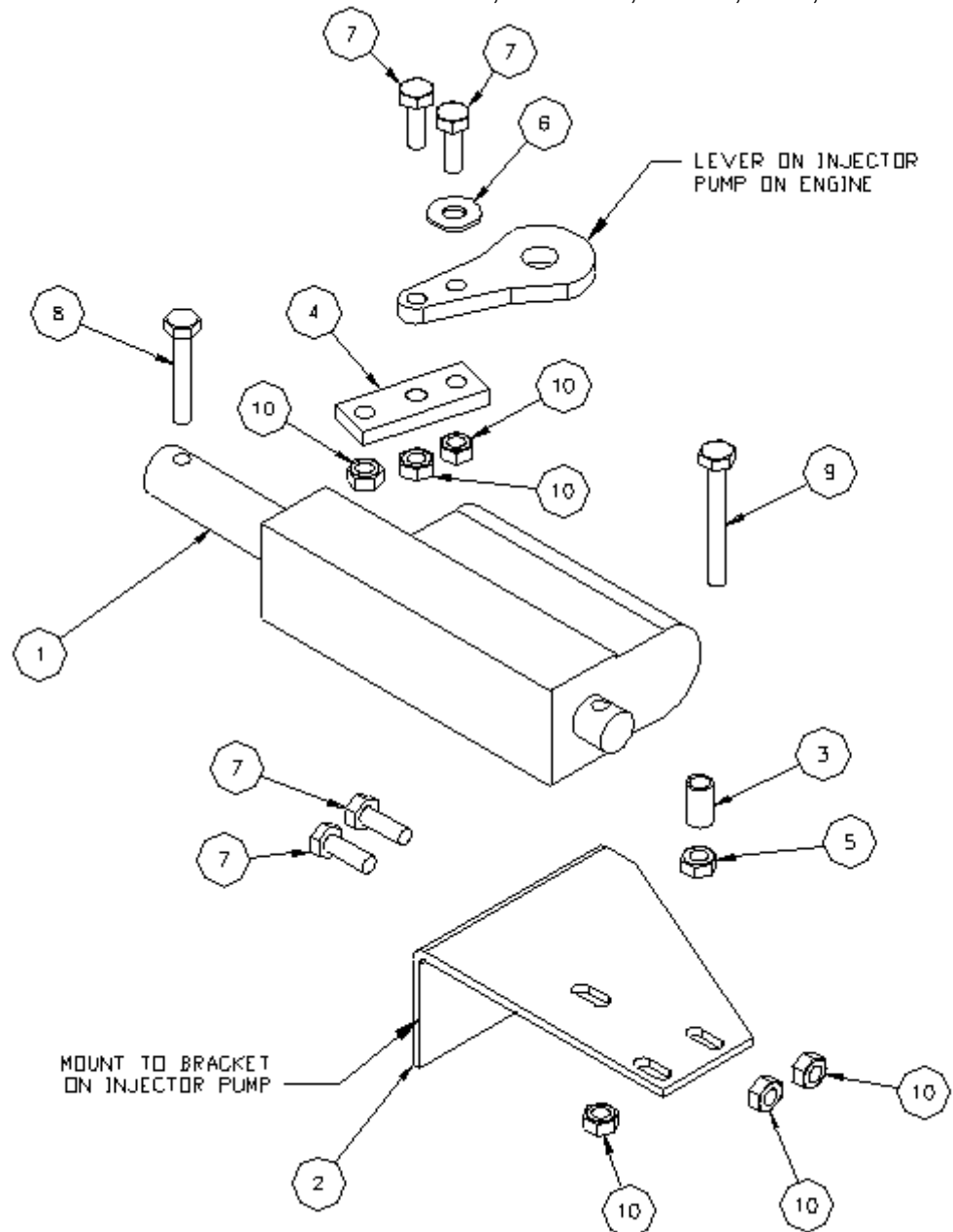

BLOWER GROUP**ROSCO RA-2000 Patcher**

STANDARD EQUIPMENT

REF: 25420

REV: D

ITEM	PART NO.	QTY.	DESCRIPTION
1	25417	1.00	BASE,BLOWER RAI-68
2	25719	1.00	AIR INLET TUBE,W/M
3	36485-01	1.50	LUBE,BLOWER,AEON PD,QUART
4	37998	1.00	AIR CLEANER,5"OUT/12" DIA
5	38007	1.00	BLOWER,POS DISPL,.395 CFR
6	38008	1.00	COUPLER,TORSIONAL,RA2000
	37568-02	1.00	FLANGE,FLYWHEEL,10.00 SAE
	37568-03	1.00	ELASTIC ELEMENT,SHORE A,65
	38008-01	1.00	HUB,1.375 BORE,.250 KEYWAY
7	72174	1.00	CLAMP,T-BOLT,5.34 TO 5.66 ID
8	80162	8.00	WASHER,SPLIT LOCK,.375
9	80257	8.00	CSHH,.500-13X2.25,GR5
10	80354	8.00	NUT,FLEXLOC,.500-13,FULL,LT
11	80972	8.00	CSSH,.375-16X.75
12	81141	8.00	WASHER,SAE,HARDENED,.500
13	853521158	1.00	INDICATOR,AIR CLEANER
14	99523	1.00	PIPE,90,02MP-02FP,MI
15	99610	1.00	PIPE,NIPPLE,02XCLOSE

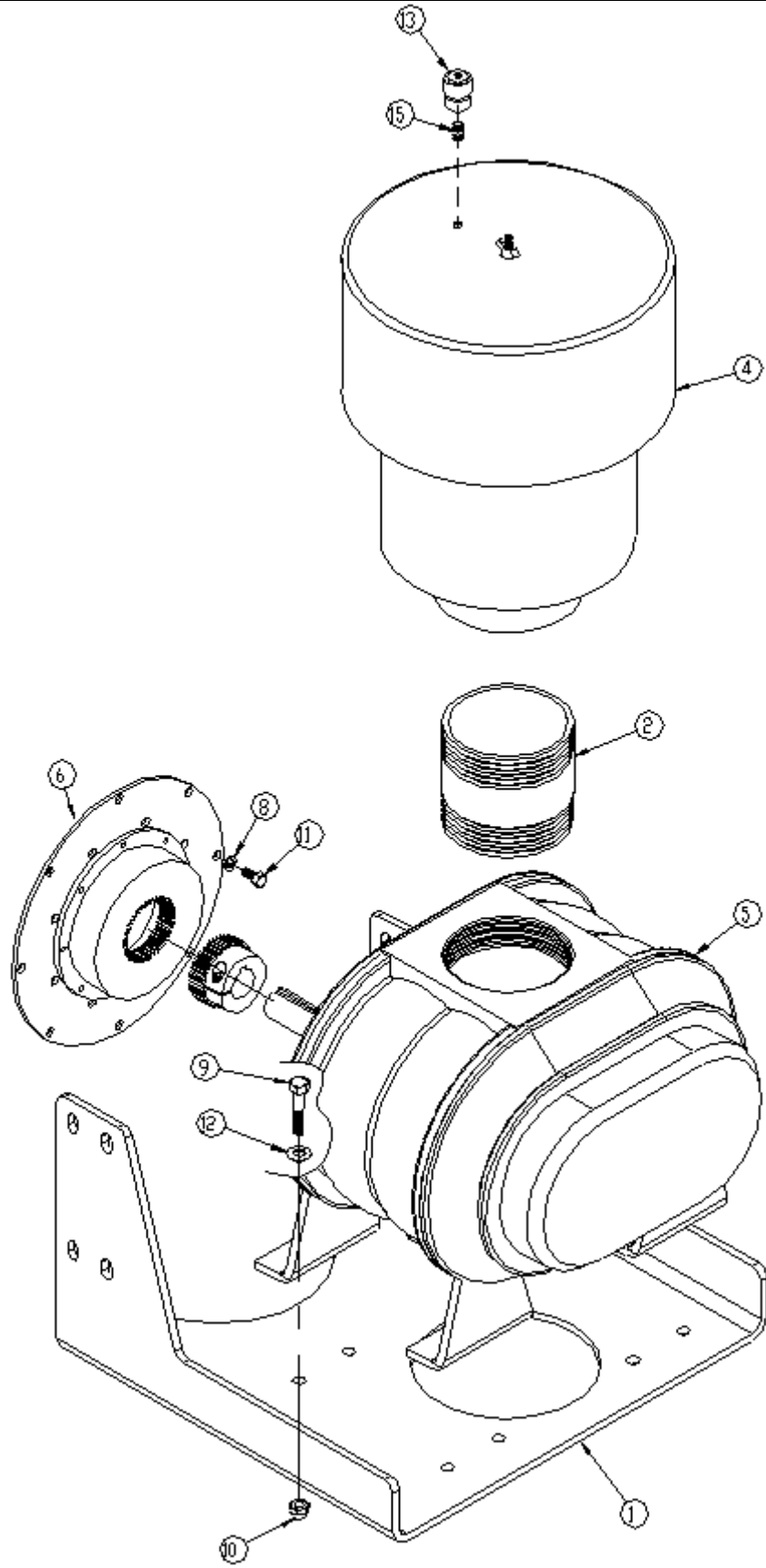

AIR INTAKE SYSTEM

ROSCO RA-2000 Patcher

STANDARD EQUIPMENT

REF: 27062

REV: A

ITEM	PART NO.	QTY.	DESCRIPTION
1	34033	2.00	MOUNTING BAND,6.50 ID
2	34031	2.00	ADPTR,RUBBER 90,3.00 ID
3	35318	1.00	ADPTR,RUBBER 45,3.00 ID
4	36019	6.00	CLAMP,T-BOLT,3.50 OD
5	37757	1.00	AIR CLEANER,3.0 IN,3.0 OUT
	37757-01	1.00	FILTER,PRIMARY ELEMENT,XLP
	37757-02	1.00	FILTER,SAFETY ELEMENT
6	36121	1.00	HOOD,AIR INLET,3.00 PLASTIC
7	80208	4.00	CSHH,.312-18X1.00,GR5
8	80351	4.00	NUT,FLEXLOC,.312-18,FULL,LT
9	90062-02	2.00	TUBE,RND,3.00X4.00
10	853521158	.00	INDICATOR,AIR CLEANER
11	871111527	1.00	CLAMP,HOSE,2.56-3.50,WORM,#48
12	26986	1.00	MOUNT,INTAKE SUPPORT

See Following Page For Elements

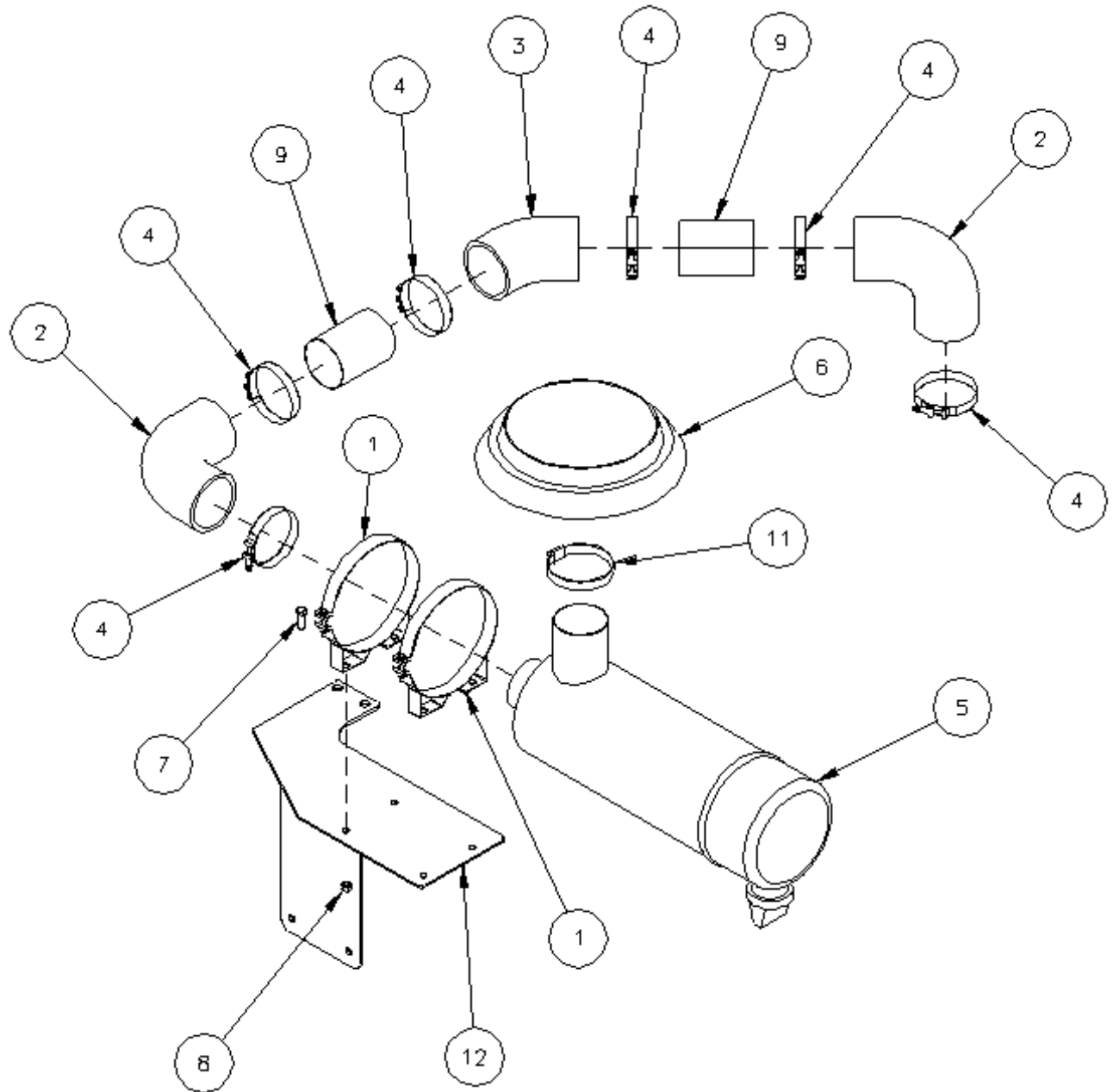

EXHAUST GROUP & FILTER KIT

ROSCO RA-2000 Patcher

STANDARD EQUIPMENT

REF: 25437

REV: A

ITEM	PART NO.	QTY.	DESCRIPTION
1	26906	1.00	TUBE,EXHAUST,RA2000
2	19261	1.00	ELBOW W/M,90 EXHAUST
3	33312	5.00	CLAMP,MUFFLER,2.5
4	34033	2.00	MOUNTING BAND,6.50 ID
5	34074	1.00	MUFFLER,EXH 6.50 OD,2.5 IN/OUT
6	35653	2.50	TUBE,FLEX EXHAUST,2.50 ID
7	36117	1.00	ELBOW,EXHAUST,SR90,2.50 OD
8	37038	1.00	PIPE,EXHAUST
9	80351	4.00	NUT,FLEXLOC,.312-18,FULL,LT
10	80208	4.00	CSHH,.312-18X1.00,GR5

27117**FILTER KIT (No Illustration)**

1	34881	1.00	FILTER,OIL CUMMINS 4A & 4B
2	72078	1.00	FILTER,FUEL,PRIMARY
3	34883	1.00	FILTER,FUEL
4	33291	1.00	FILTER,FUEL,DIESEL,INLINE
5	38023-01	1.00	SCREEN,100 MESH,Y-STRAINER
6	36531-1	1.00	ELEMENT,FILTER
7	37757-01	1.00	FILTER,PRIMARY ELEMENT,XLP
8	37757-02	1.00	FILTER,SAFETY ELEMENT

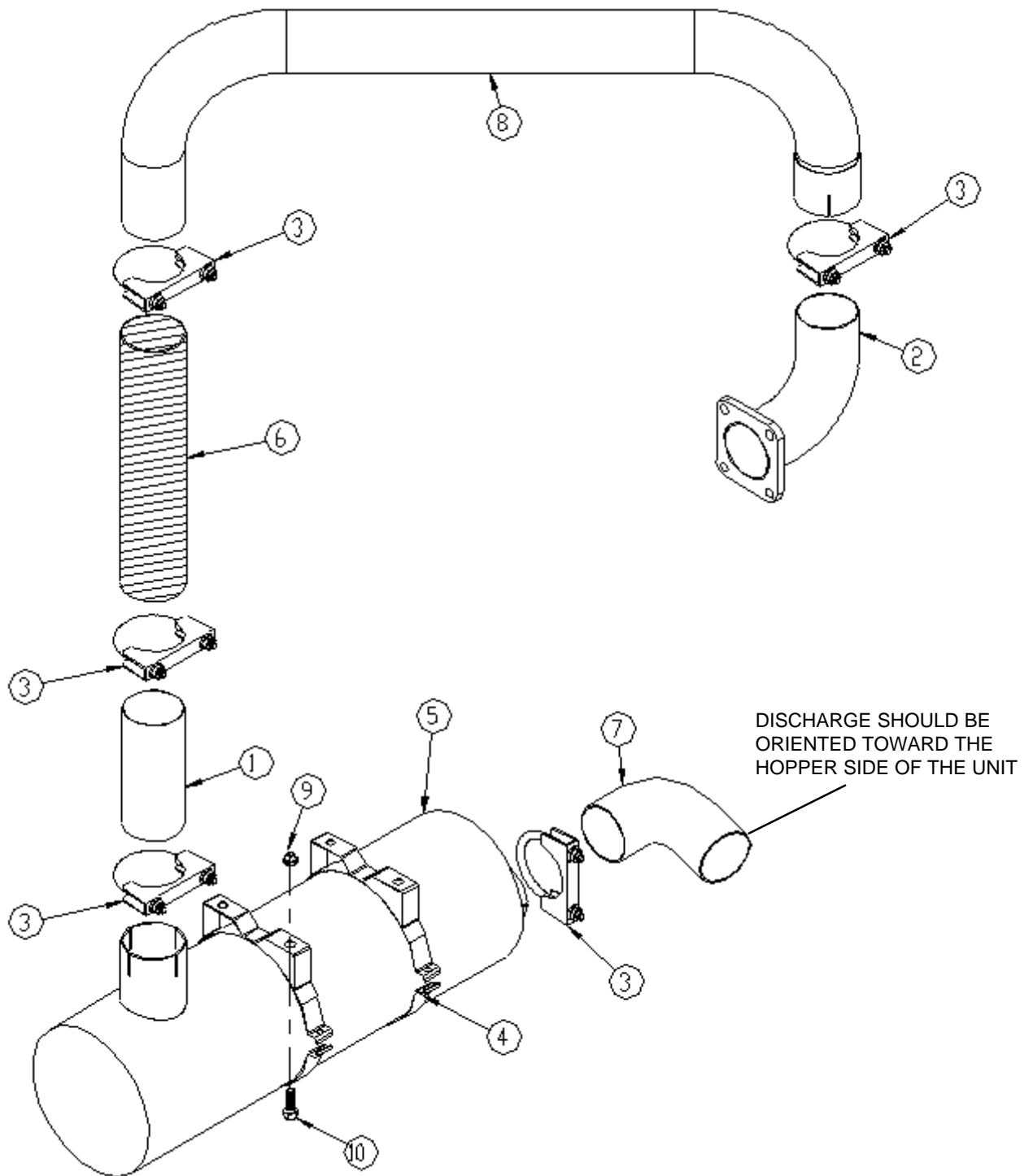

INSTRUMENT PANEL GROUP

ROSCO RA-2000 Patcher

STANDARD EQUIPMENT

REF: 25544

REV: B

ITEM	PART NO.	QTY.	DESCRIPTION
1	21726	1.00	INSTRUMENT HOUSING W/M
2	21728	1.00	INSTRUMENT PANEL W/M
3	33271-4	2.00	WIRE,16 GA,GREEN
4	33271-1	1.50	WIRE,16 GA,BLACK
5	33271-10	1.50	WIRE,16 GA,GREEN/WHITE STRIPE
6	33271-11	2.00	WIRE,16 GA,BLUE
7	33271-12	1.50	WIRE,16 GA,RED/BLACK STRIPE
8	33271-13	1.50	WIRE,16 GA,BLACK/YELLOW STRIPE
9	33271-14	1.50	WIRE,16 GA,YELLOW/RED STRIPE
10	33271-15	1.50	WIRE,16 GA,BROWN/YELLOW STRIPE
11	33271-16	1.50	WIRE,16 GA,PURPLE/WHITE STRIPE
12	33271-17	1.50	WIRE,16 GA,WHITE/BLACK STRIPE
13	33271-18	1.50	WIRE,16 GA,BLUE/RED STRIPE
14	33271-19	1.50	WIRE,16 GA,DK GREEN/YEL STRIPE
15	33271-2	1.50	WIRE,16 GA,YELLOW
16	33271-20	1.50	WIRE,16 GA,GRAY/BLACK STRIPE
17	33271-21	1.50	WIRE,16 GA,ORANGE/YEL STRIPE
18	33271-3	1.50	WIRE,16 GA,BROWN
19	33271-6	1.50	WIRE,16 GA,ORANGE
20	33271-7	2.00	WIRE,16 GA,RED
21	33271-8	1.50	WIRE,16 GA,PINK
22	33271-9	2.00	WIRE,16 GA,PURPLE
23	33596	6.00	TIE WRAP,.188X7.5
24	33600	5.00	TERM,PUSH-ON,.25,FEM,16-14 GA
25	33620	5.00	TERM,RING,12-10 GA,#10 STUD
26	34468	2.00	CONN HOUSING,CAP,12 CIRCUIT
27	34469	17.00	CONTACT,PIN,20-14 GA
28	35123	8.00	TERM,RING,16-14 GA,#6 STUD
29	35362	1.00	GAUGE,PRESS,OIL
30	35364	1.00	GAUGE,TEMP,WATER
31	35369	1.00	GAUGE,AMMETER,60-0-60
32	35630	1.00	TACH/HOUR METER
33	36085	4.00	RELAY,SPDT,40AMP,12VDC
34	36086	4.00	BRACKET,RELAY MOUNT
35	36118-2	20.00	TERM,CRIMP,16-14 GA
36	36340	2.00	FUSE,BLADE,10AMP,ATC-10
37	36341	1.00	FUSE,BLADE,15AMP,ATC-15
38	36695	1.00	FUSE BLOCK,BLADE-TYPE,6 POS
39	36699	1.00	SWITCH,IGNITION,3 POS,30 AMP
40	36746	2.00	FUSE,BLADE,5AMP,ATC-5
41	36982	1.00	DECAL,FUSE PANEL,.63X3.31
42	36991	1.00	DECAL,FUSE LOCATION,RA200
43	36992	1.00	DECAL,RELAY LOCATION,THROTTLE
44	38026	1.00	DECAL,RELAY LOCATION
45	71716	4.00	MACH SCR,PH,#10-24X.75
46	71861-1	3.50	WIRE,10 GA,WHITE

Rotated View

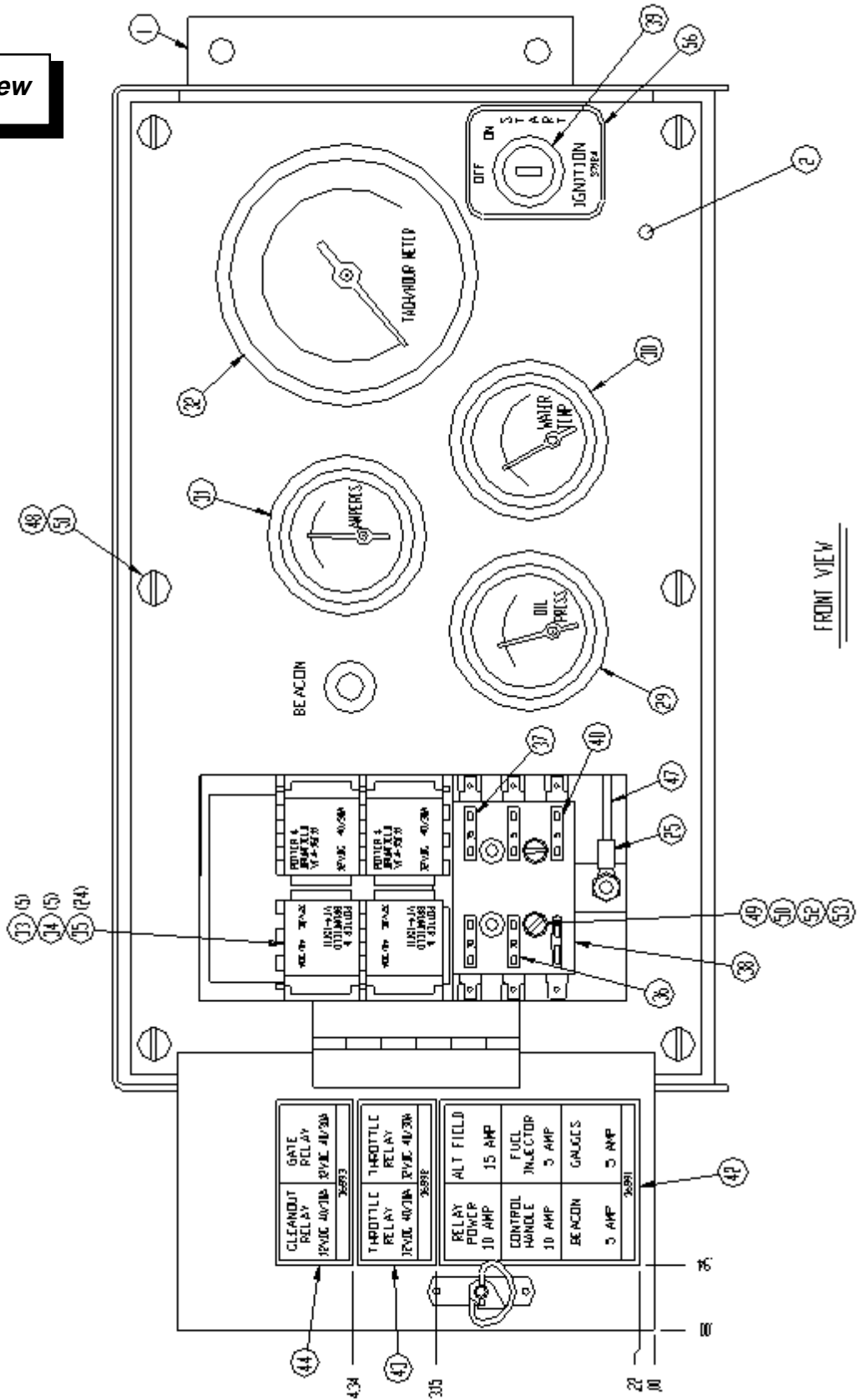

INSTRUMENT PANEL GROUP**ROSCO RA-2000 Patcher**

STANDARD EQUIPMENT

REF: 25544

REV: B

ITEM	PART NO.	QTY.	DESCRIPTION
47	71861-2	2.50	WIRE,10 GA,RED
48	80703	6.00	WASHER,LOCK,INT TOOTH,.250
49	80798	2.00	MACH SCR,PH,#10-24X1.00
50	80824	6.00	NUT,HEX,#10-24
51	80901	6.00	MACH SCR,PH,.250-20X.75
52	80995	6.00	WASHER,TYPE A PLAIN,#10
53	871071601	6.00	WASHER,SPLIT LOCK,#10
56	37124	1.00	DECAL,IGNITION SWITCH,RA200
57	851390204	5.00	TERM,RING,16-14 GA,#10 STUD
58	36118-3	2.00	TERM,CRIMP,12-10 GA

ROTATED VIEW

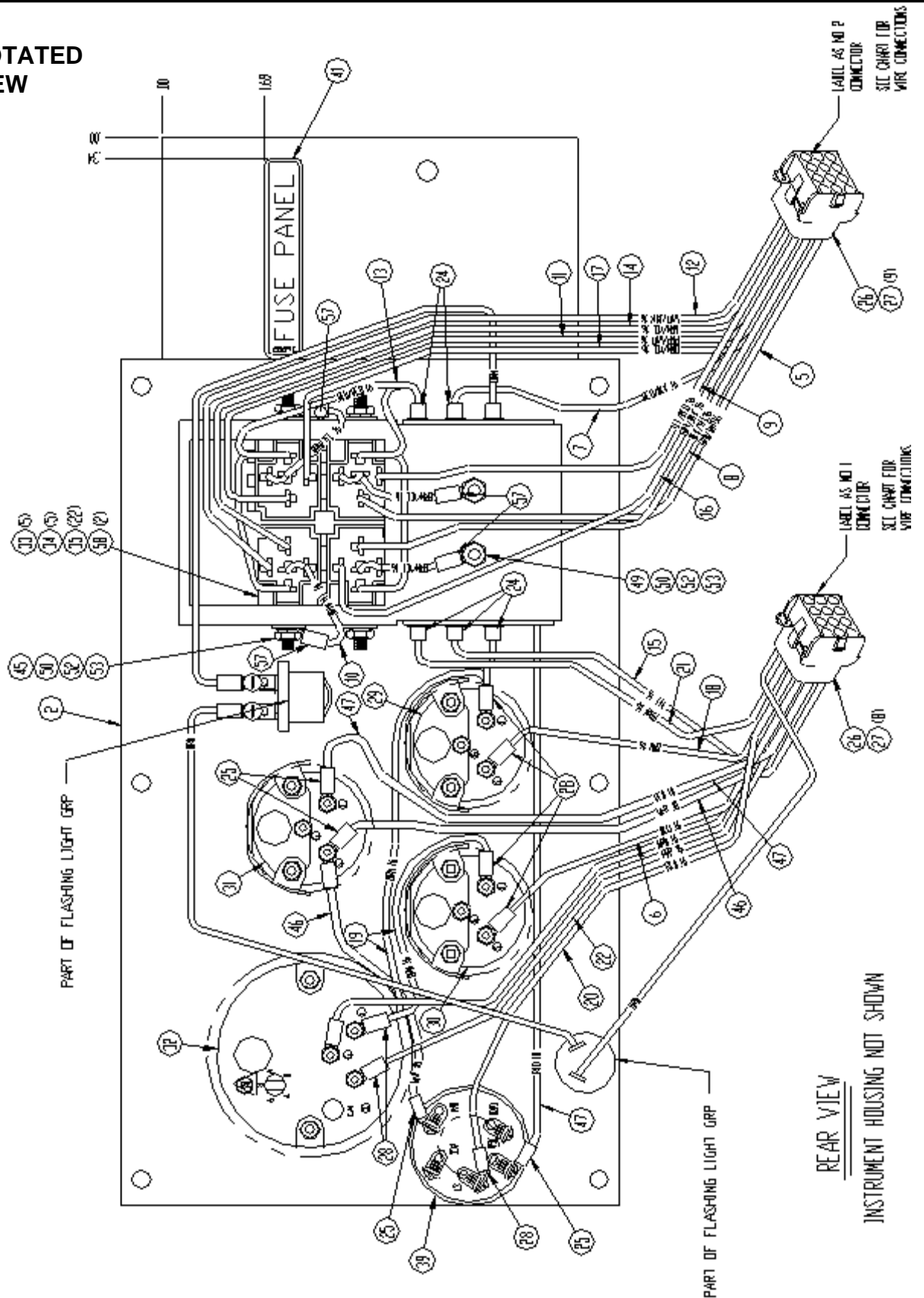

INSTRUMENT WIRING GROUP

ROSCO RA-2000 Patcher

STANDARD EQUIPMENT

REF: 27215

REV: B

ITEM	PART NO.	QTY.	DESCRIPTION
1	25544	1.00	PANEL,INSTRUMENT GRP,RA2000 (See Detail Previous Pages)
2	27352	1.00	HARNES,CONTROL HANDLE (See Schematic at End of This Section)
3	25545	1.00	HARNES,BOOM,RA2000 (See Schematic at End of This Section)
5	951250115	1.00	KIT,HORN

RotatedView

(See Schematic at End of This Section)

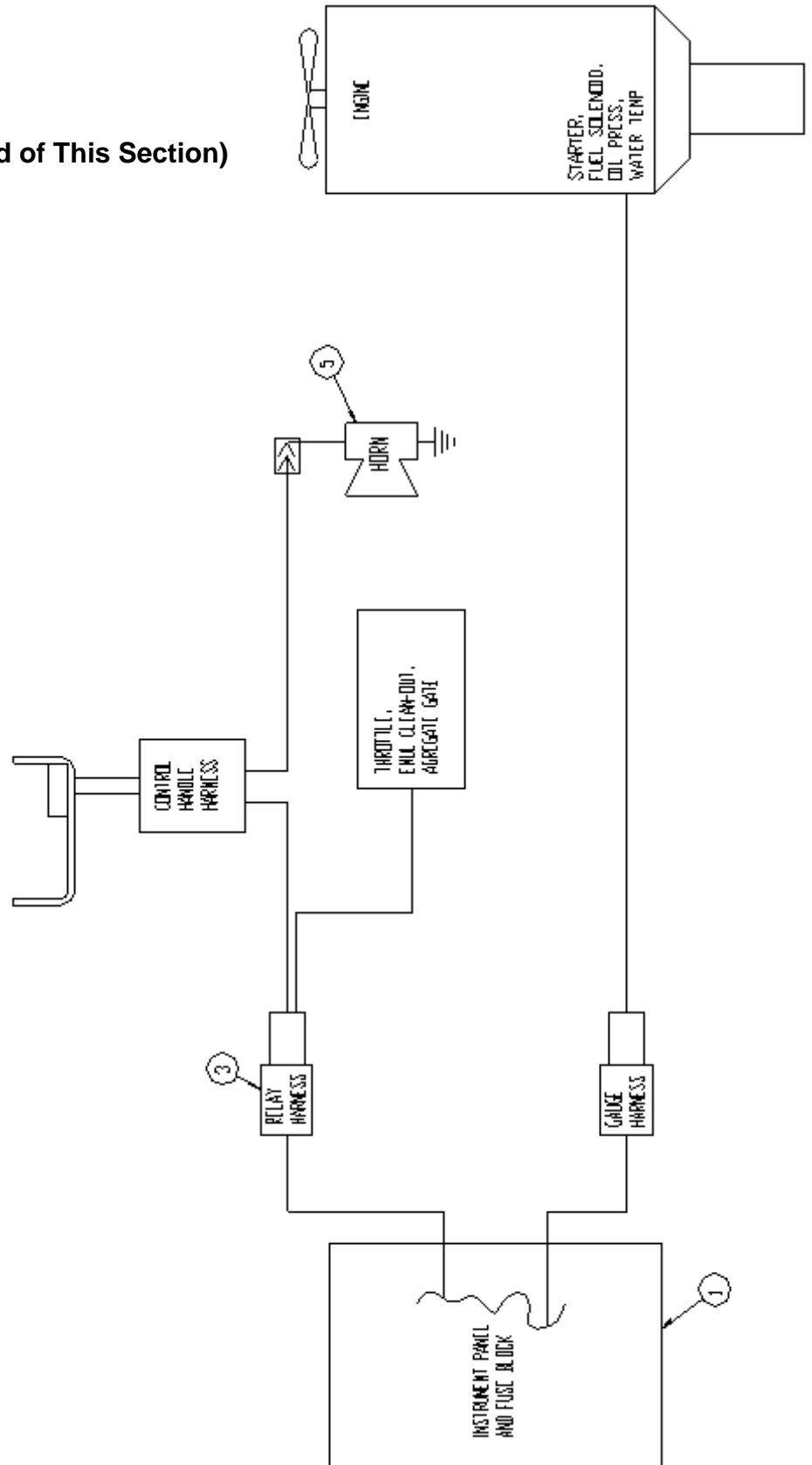

ELECTRICAL GROUP, 120V

ROSCO RA-2000 Patcher

STANDARD EQUIPMENT

REF: 25392

REV: C

ITEM	PART NO.	QTY.	DESCRIPTION
1	37141	12.00	CORD,ELEC,3WIRE,12GA,300V
2	34167	1.00	LIGHT, GREEN INDICATOR
4	34732	2.00	CONNECTOR, STR, FLEX CONDUIT, .50
5	36681	2.00	ELEMENT, HEATER, 4500 W @ 240VAC
6	36682	1.00	THERMOSTAT, ELEC, 110-170 DEG F
7	37591	1.00	RCPT, ELEC, MALE, 20A, 125V, FLG IN
8	37721	1.00	CAP, WEATHER SEAL
9	80496	2.00	MACH SCR, PH, #10-32X.25, PHIL
10	851390204	11.00	TERM, RING, 16-14 GA, #10 STUD
11	871071601	2.00	WASHER, SPLIT LOCK, #10
12	81150	2.00	SCR, SLFTP, PH, #10X.500, AB
13	37728	1.00	PLUG, ELEC, FEMALE, 20A, 125V

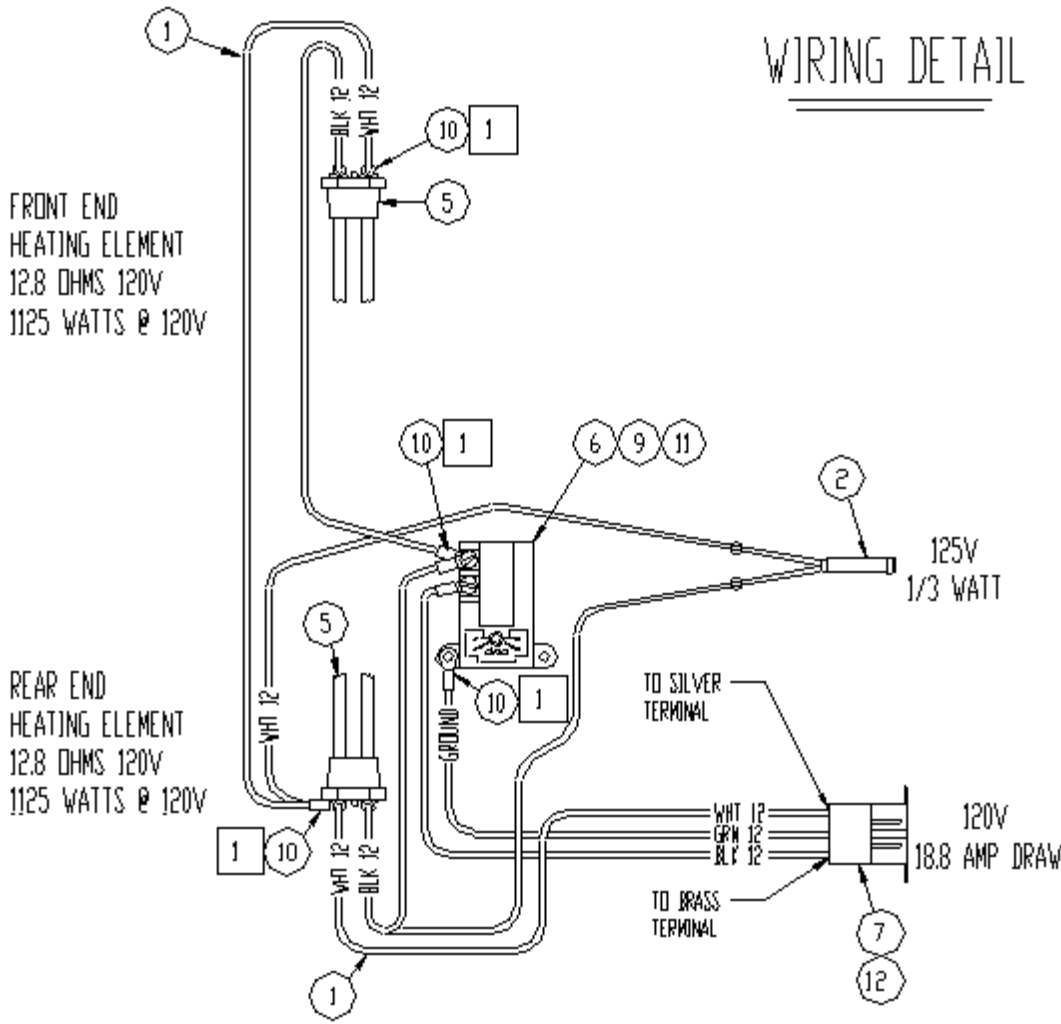

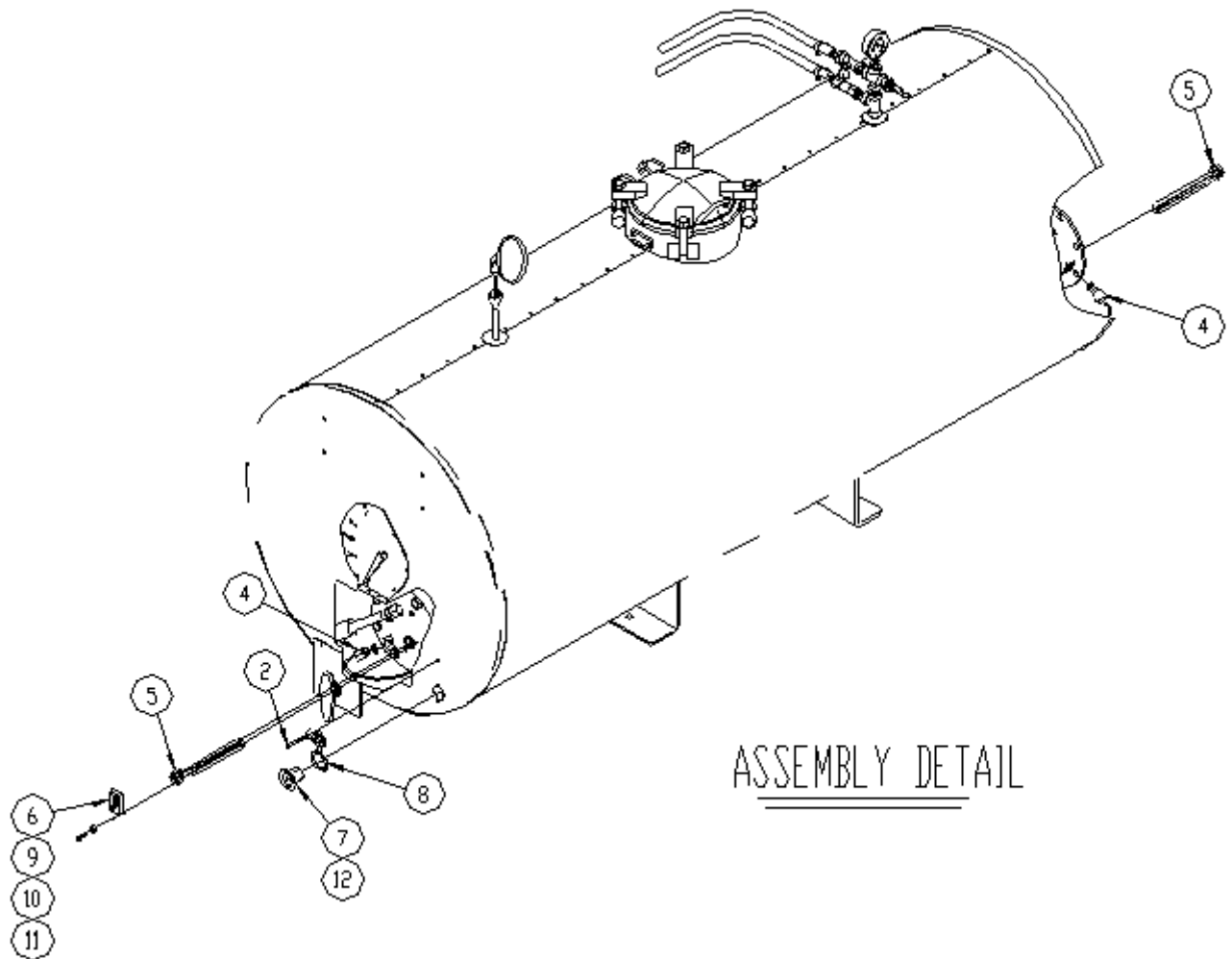

NOTE:

- 1 SILICONE ALL TERMINALS
- 2 PLACE PLUG (ITEM 13) IN CAB OF THE TRUCK

EMULSION TANK GROUP

ROSCO RA-2000 Patcher

STANDARD EQUIPMENT

REF: 25391

REV: I

ITEM	PART NO.	QTY.	DESCRIPTION
1	25390	1.00	EMULSION TANK INSULATE,RA2000
2	20963	1.00	HINGE,CONTROL BOX
3	25789	1.00	DOOR,SERVICE,EMUL TANK
4	23729	1.00	COVER,POTENTIOMETER
5	25393	1.00	HANDLE EXTENTION
6	X341	12.00	HOSE,06,PUSH-ON,250,BLUE
7	31046	1.00	FITT,STR 08MP-08HB,PUSH-ON
8	33137	4.00	CSHH,.750-10X2.50,GR5
9	33163	7.00	CLAMP,HOSE,.50-.91,WORM,#08
10	34393	1.00	VLV,CHECK,08FP,.50 PSI CRACK
11	33750	1.00	VLV,AIR,SAFETY,125PSI,04 NPT
12	34402	1.00	VLV,BALL,1.00,BRONZE
13	35812	1.00	LOCK,WITH OFFSET CAM
14	36622	1.00	VLV,BALL,08 NPT,T HANDLE
15	36656	1.00	GAUGE,PRESS,0-160 PSI,2.5 OD
16	36662	1.00	VLV,BALL,3-WAY,08 NPT
17	36665	10.00	INSULATION,TUBE,1.12IDX.38WALL
18	80909	4.00	SCR,SLFDRL,HH,.250-14X1.00
19	5470	1.00	THERM,DIAL,5.0 FACE,500 F
20	5822	2.00	VLV,DRAIN COCK,.25
21	6352	66.00	HOSE,08,PUSH-ON,250
24	80147	8.00	WASHER,TYPE A PLAIN,.750
25	80300	1.00	SET S,HSKT,KCUP,.250-20X.25
26	80357	4.00	NUT,FLEXLOC,.750-10,FULL,LT
27	X427	1.00	FITT,STR 08MP-08HB,CRIMPED
29	81160	12.00	SCR,SLFDRL,HH,#10X1.00,#3PT
30	99498	1.00	PIPE,CROSS,08FP,MI
31	99247	1.00	PIPE,BUSH,2.00MP-16FP,MI
32	80036	2.00	NUT,HEX,.250-20
33	99539	1.00	PIPE,PLUG,16MP,SQ HD,MI
34	80185	2.00	CSHH,.250-20X1.00,GR5
35	99596	4.00	PIPE,NIPPLE,08XCLOSE
36	99980	2.00	PIPE,BUSH,08MP-04FP,STL
37	91378	8.00	ANTIFREEZE,DEX-COOL
38	8119	1.00	POINTER ASSY
39	80392	1.00	SET S,.250-20X.50
40	23735	2.00	NUT,FLOAT ROD PIVOT
41	35845	1.00	FLOAT,4.00 SPHERICAL SS304
42	37505	2.00	COLLAR,SHAFT,SPLT,.50IDX1.12OD
43	37506	2.00	O-RING,.487IDX.103CS,VITON
44	99271	2.00	PIPE,90,2.00FP,MI
45	99440	1.00	PIPE,BUSH,2.00MP-08FP,MI
46	99606	1.00	PIPE,NIPPLE,16XCLOSE
47	X144	1.00	FITT,STR 08MP-06HB,CRIMPED
49	99569	1.00	PIPE,TEE,08FP,MI
50	38377	12.00	INSULATION,TUBE,3.62IDX.5WX72"
51	99759	2.00	PIPE,NIPPLE,2.00X3.50

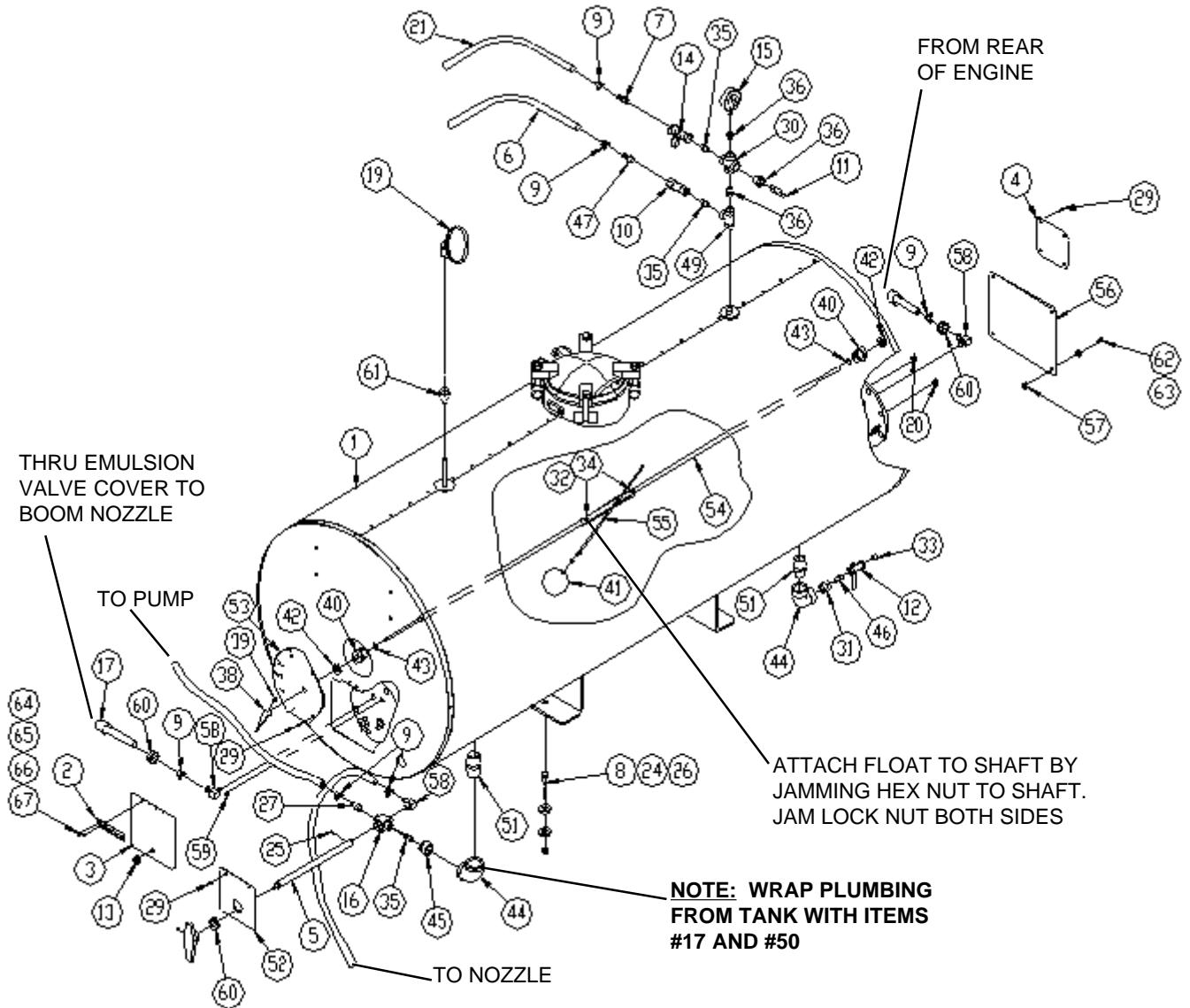

52	25409	1.00	BRACKET,EXTENSION
53	25476	1.00	CONTENTS PLATE, RA2000/RA300
54	25411	1.00	FLOAT PIVOT ROD W/M, RA2000
55	23725	1.00	W/M,FLOAT ROD
56	25684	1.00	PLATE,COVER
57	37830	8.00	NUT,INSERT, .375-16,.027-.150,S
58	33328	3.00	FITT,90 08MP-08HB,CRIMPED
59	99535	1.00	PIPE,PLUG,04MP,SQ HD,MI
60	35465-05	3.00	GROMMET,INSULATION,1.00ID
61	99551	1.00	PIPE,RED,08FP-04FP-MI
62	80221	4.00	CSHH,.375-16X1.00,GR5
63	80142	4.00	WASHER,TYPE A PLAIN,.375
64	80926	8.00	MACH SCR,PH,#8-32X.75
65	81014	8.00	WASHER,TYPE A PLAIN,#8
66	80793	8.00	NUT,HEX,#8-32
67	80792	8.00	WASHER,SPLIT LOCK,#8

AGGREGATE HOPPER GROUP

ROSCO RA-2000 Patcher

STANDARD EQUIPMENT

REF: 25724

REV: B

ITEM	PART NO.	QTY.	DESCRIPTION
1	25734	1.00	GUARD,RECEIVING HOPPER
2	25738	1.00	EDUCTOR RECEIVER W/M
3	25739	1.00	EDUCTOR NOZZLE W/M
4	25742	1.00	SLIDE GATE,EDUCTOR
5	25743	1.00	FLOW GATE,EDUCTOR
6	25744	8.00	SPACER,EDUCTOR,.50 THICK
7	25745	1.00	EDUCTOR W/M
8	25749	4.00	SPACER,EDUCTOR,.25 THICK
9	25751	2.00	BRK'T,SIDE RUBBER
10	25752	1.00	BRK'T,FRONT RUBBER
11	34040	2.00	CLAMP,MUFFLER,4.00
12	37301	1.00	CYL,3.50X4.00,250PSI,11.17 OA
13	37997	1.00	SILENCER,3.0 NPT
14	38000	4.50	HOSE,HOT AIR,3.5ID,300F,150PSI
15	38046	1.00	SCREW,WING .375-16 X 1.00
16	38065	2.00	RUBBER,HOPPER SIDE
17	38066	1.00	RUBBER,HOPPER FRONT
18	38067	1.00	RUBBER,HOPPER REAR
19	80222	4.00	CSHH,.375-24X1.00,GR5
20	80081	1.00	NUT,HEX,JAM,1.000-8
21	80140	34.00	WASHER,TYPE A PLAIN,.250
22	80142	1.00	WASHER,TYPE A PLAIN,.375
23	80162	4.00	WASHER,SPLIT LOCK,.375
24	80185	34.00	CSHH,.250-20X1.00,GR5
25	80350	34.00	NUT,FLEXLOC,.250-20,FULL,LT
26	871111605	2.00	CLAMP,LOOP,.50 OD PLSTC COVER
27	99267	1.00	PIPE,45,3.00FP,MI
28	90590-5	1.00	PIPE,TOE,3.00X4.00
29	91399	1.00	PIPE,BUSH 5.00MP-3.00FP,MI
30	99273	1.00	PIPE,90,3.00FP,MI
31	99806	1.00	PIPE,NIPPLE,3.00X9.00
32	80224	4.00	CSHH,.375-16X1.25,GR5
33	80996	4.00	WASHER,SAE PLAIN,.375
34	71627	6.00	CSHH,.500-13X1.50,GR5
35	80144	4.00	WASHER,TYPE A PLAIN,.500
36	80354	6.00	NUT,FLEXLOC,.500-13,FULL,LT
37	25689	1.00	HOOK,HOSE,4.00

*Other Views
of This
Group
Shown on
Following
Pages...*

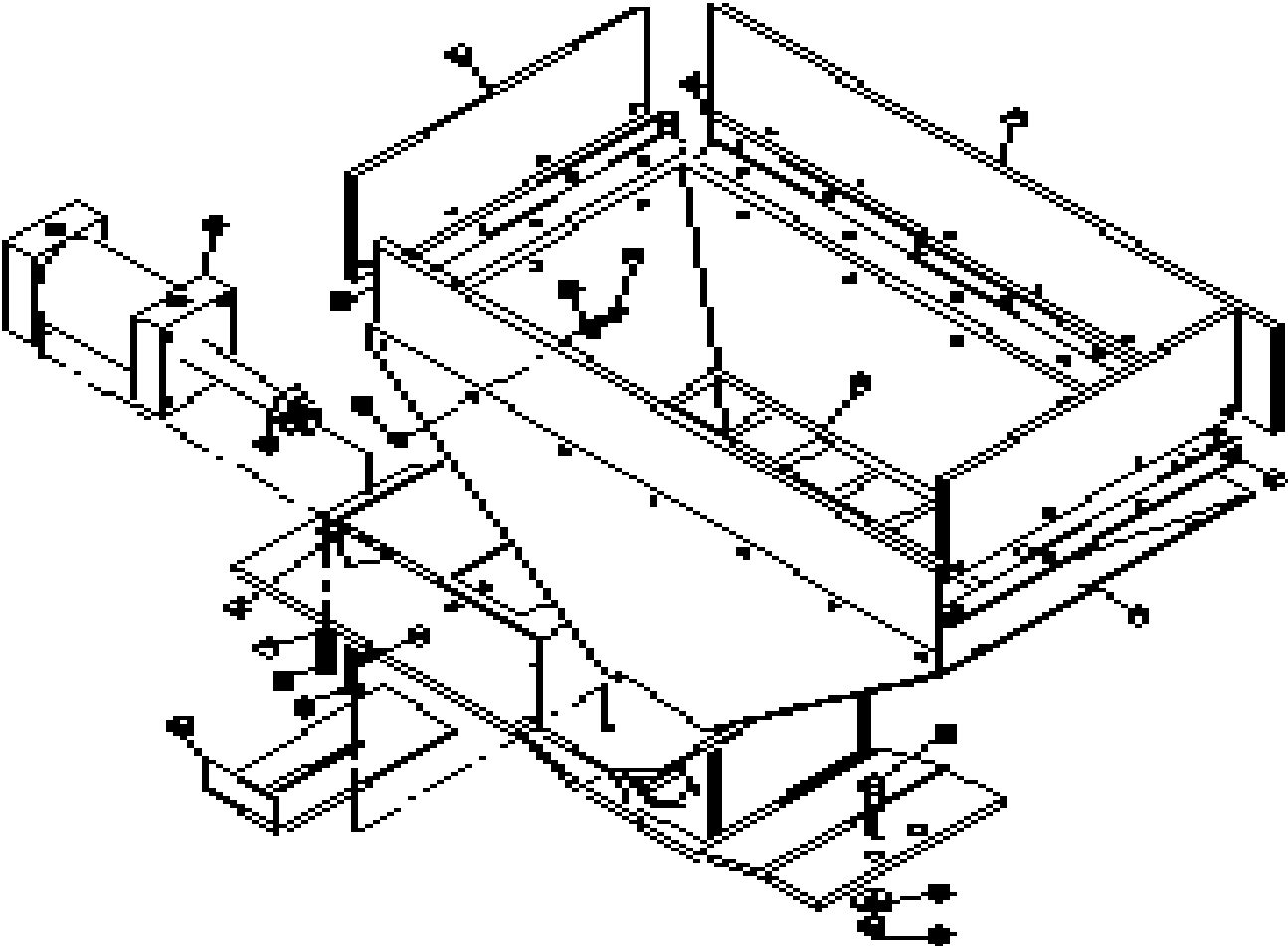

Rotated View

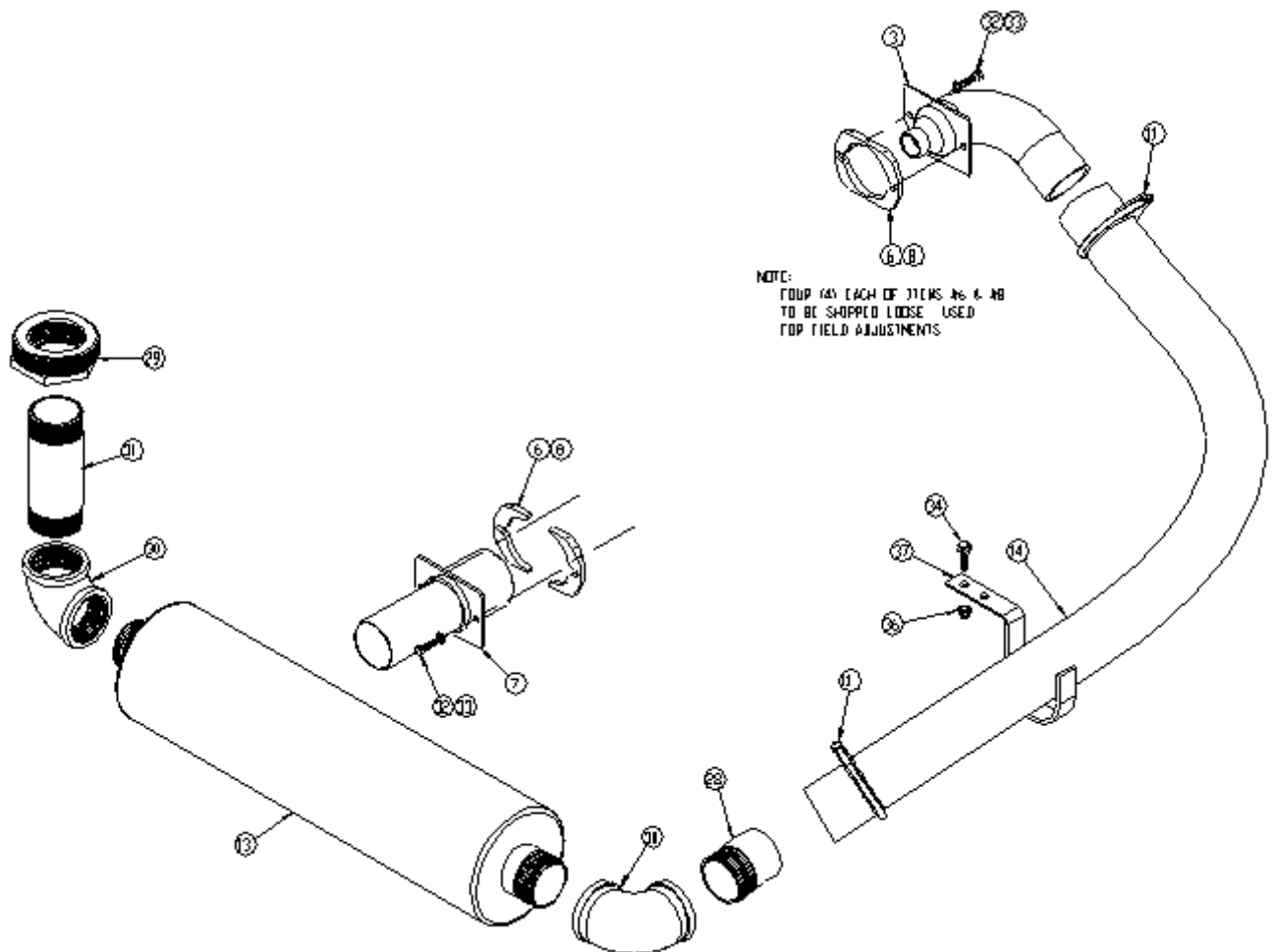

TAIL GATE GROUP

STANDARD EQUIPMENT

ROSCO RA-2000 Patcher

REF: 25651

REV: A

ITEM	PART NO.	QTY.	DESCRIPTION
1	25504	1.00	AGGREGATE,TUBE W/M
2	38018	1.00	HOSE, AGGREGATE 5.00X36.00
3	33172	1.00	CLAMP,HOSE,5.62-6.50,WORM,#96
4	36542	1.00	TIE DOWN,RUBBER,15,W/HOOKS

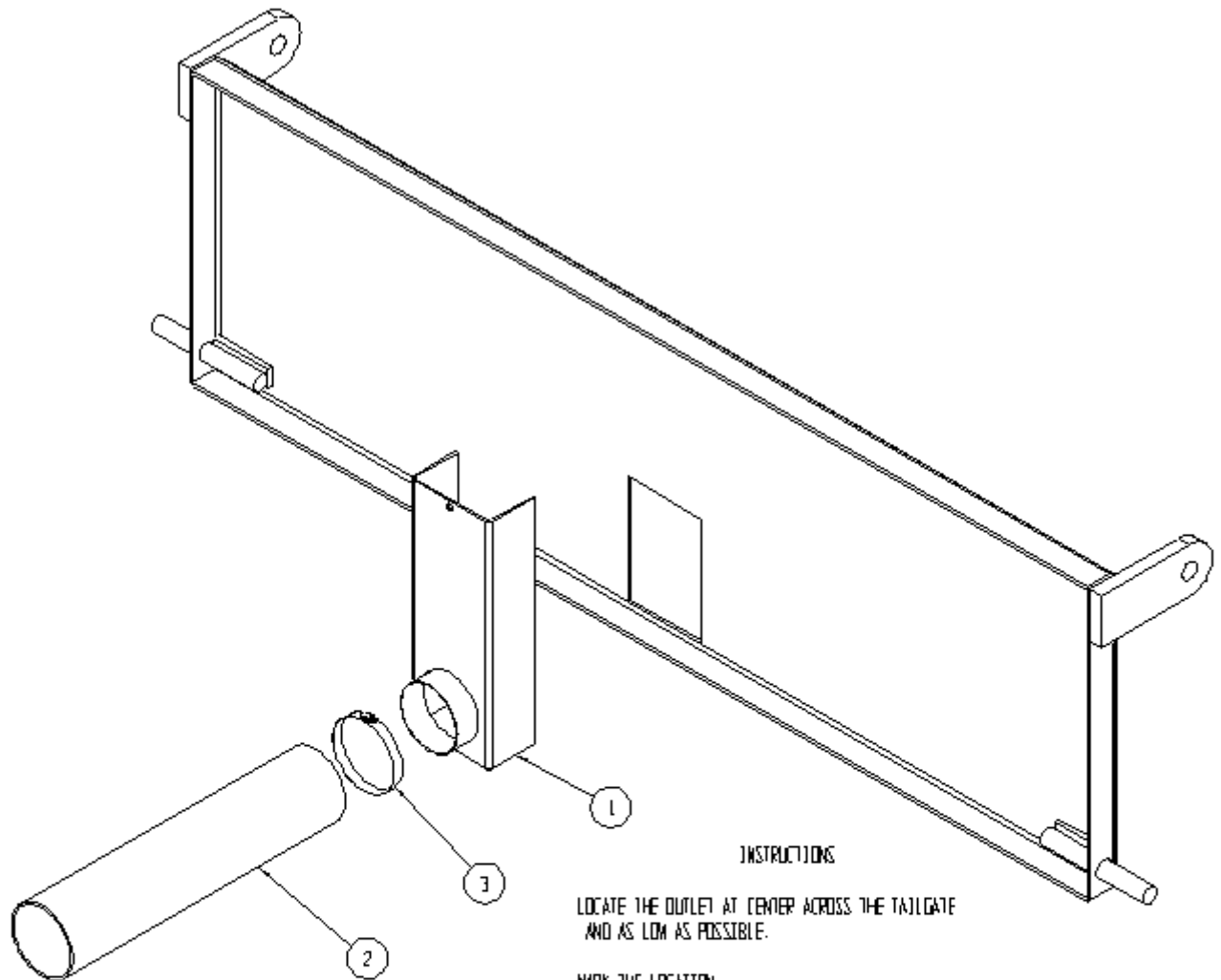

INSTRUCTIONS

LOCATE THE OUTLET AT CENTER ACROSS THE TAILGATE AND AS LOW AS POSSIBLE.

MARK THE LOCATION.

CUT A 6 1/2" x 9 1/2" HOLE IN THE TAILGATE. THE 6 1/2" WIDTH IS BETWEEN THE VERTICAL MARKS AND THE 9 1/2" HEIGHT IS FROM THE BOTTOM MARK UP.

WELD THE OUTLET TO THE TAIL GATE.

ATTACH THE HOSE TO THE TUBE WITH THE HOSE CLAMP.

ATTACH THE RUBBER STRAP ON THE HOLE OF THE OUTLET. SQUEEZE THE HOSE TOGETHER TO PREVENT LOSS. ATTACH THE OTHER END TO THE END OF THE HOSE WHEN NOT IN USE.

See Page 4.3 For Detailed Instructions

FRAME GROUP

ROSCO RA-2000 Patcher

STANDARD EQUIPMENT

REF: 27956

REV: 0

ITEM	PART NO.	QTY.	DESCRIPTION
1	25829	1.00	HARNESS,WIRE FRAME RA2000
2	22081	1.00	SWITCH,BREAKAWAY
5	27955	1.00	FRAME W/M,RA2000
6	23481	1.00	FENDER,BOLT-ON,LH
7	25839	1.00	FENDER,BOLT-ON,RH
9	33519	4.00	WHEEL,15X6JJ,6 HOLE,5.50 B.C.
10	33799	4.00	TIRE VALVE,TUBELESS,.453,1.25
11	35139	4.00	CONNECTOR,SEALED,TOWER,2-PIN
12	35342	4.00	TIRE,RADIAL,ST225/75-R15,C
13	35869	2.00	AXLE ASSY,5200 LB CAP,ELEC BK
14	36165	8.00	TERM,SEALED CONN,16-14 GA,FEM
15	36623	8.00	SEAL,CABLE,14 GA
16	80037	19.00	NUT,HEX,.312-18
18	80140	2.00	WASHER,TYPE A PLAIN,.250
19	80141	19.00	WASHER,TYPE A PLAIN,.312
21	80161	19.00	WASHER,SPLIT LOCK,.312
24	80185	1.00	CSHH,.250-20X1.00,GR5
26	80350	36.00	NUT,FLEXLOC,.250-20,FULL,LT
29	871111605	21.00	CLAMP,LOOP,.50 OD PLSTC COVER
30	871111609	14.00	CLAMP,LOOP,.625 OD,PLSTC COVER
31	33204	14.00	SPRING BOLT,.562
32	33205	14.00	NUT,SPRING BOLT HEX,.562
33	38740	8.00	SHACKLE LINK,3.25 C-C
34	38741	2.00	EQUALIZER

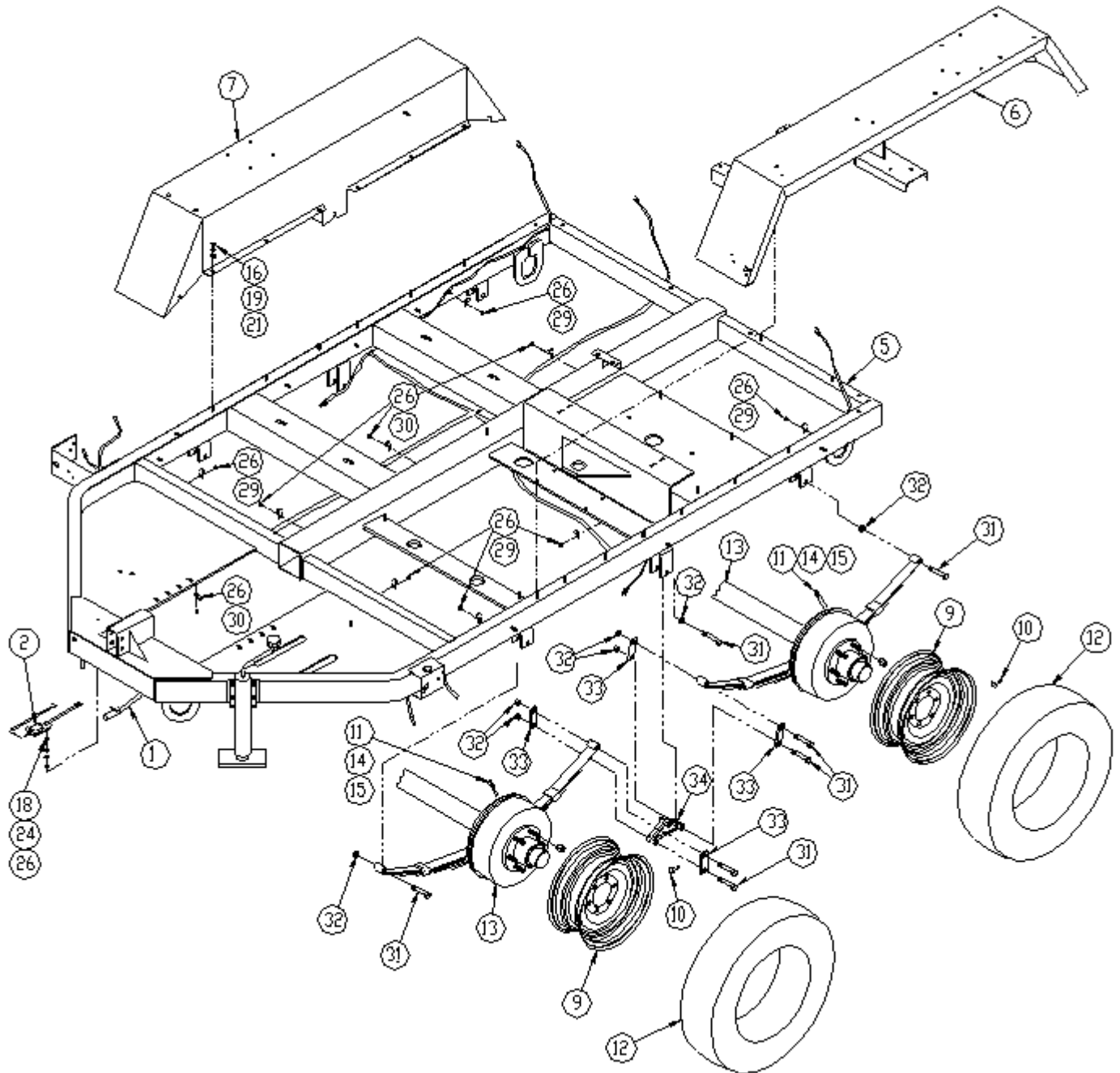

BOOM AND HOSE GROUP

ROSCO RA-2000 Patcher

STANDARD EQUIPMENT

REF: 25785

REV: E

ITEM	PART NO.	QTY.	DESCRIPTION
1	25599	1.00	NOZZLE ASSY,RA2000
2	25604	1.00	ASSY,BOOM CONTROL
3	25783	1.00	BOOM SUB ASSY
4	5442	9.00	CABLE,WIRE ROPE,.125-7X19G
5	71816	2.00	THIMBLE,CABLE,.250
6	35377	8.00	CLIP,WIRE ROPE,.063
7	5347	3.00	HOSE,04,PUSH-ON,LOW PRESS
8	37200	1.00	LINK,QUICK,.188 CHAIN
9	35403	3.00	SLEEVE,ABRASION,NYLON,.71ID
10	34040	1.00	CLAMP,MUFFLER,4.00
11	38429	24.50	HOSE,POLY,3.50ID,CONVOL. COVER
12	32874	1.00	VLV,BALL,08-BRASS
13	25729	1.00	LEVER,08 BALL VALVE
14	31046	2.00	FITT,STR 08MP-08HB,PUSH-ON
15	33063	2.00	U-BOLT,.250-20,1.12IW,2.00IL
16	80036	4.00	NUT,HEX,.250-20
17	80140	6.00	WASHER,TYPE A PLAIN,.250
18	36664	18.00	INSULATION,TUBE,1.62IDx.38WALL
19	37966	1.00	SLEEVE,ABRASION,10.0X216.0
20	25747	1.00	HOLDER,WASTE SOLVENT PAIL
21	25716	1.00	W/M,BOOM HOLDER,FENDER
22	80208	4.00	CSHH,.312-18X1.00,GR5
23	80037	4.00	NUT,HEX,.312-18
24	80141	4.00	WASHER,TYPE A PLAIN,.312
25	80161	4.00	WASHER,SPLIT LOCK,.312
26	81038	1.00	EYE BOLT,.250-20X2.00X.56ID
27	36542	2.00	TIE DOWN,RUBBER,15,W/HOOKS
28	25671	1.00	WASTE BUCKET, W/M
29	25776	1.00	PLATE,WASTE BUCKET
30	20954	1.00	CAP W/M, 2 NPT
31	99759	1.00	PIPE,NIPPLE,2.00X3.50
32	80221	3.00	CSHH,.375-16X1.00,GR5
33	80038	5.00	NUT,HEX,.375-16
34	80142	5.00	WASHER,TYPE A PLAIN,.375
35	80162	5.00	WASHER,SPLIT LOCK,.375
36	33163	9.00	CLAMP,HOSE,.50-.91,WORM,#08
37	80194	1.00	CSHH,.250-20X1.50,GR5
38	80350	2.00	NUT,FLEXLOC,.250-20,FULL,LT
39	80881	2.00	CRG BOLT,.375-16X1.25,GR5
40	37966-027	2.00	SLEEVE,ABRASIVE,9.50 X 27.00

ROSCO RA-2000 Patcher

REF: 25785

REV: E

BOOM AND HOSE GROUP

STANDARD EQUIPMENT

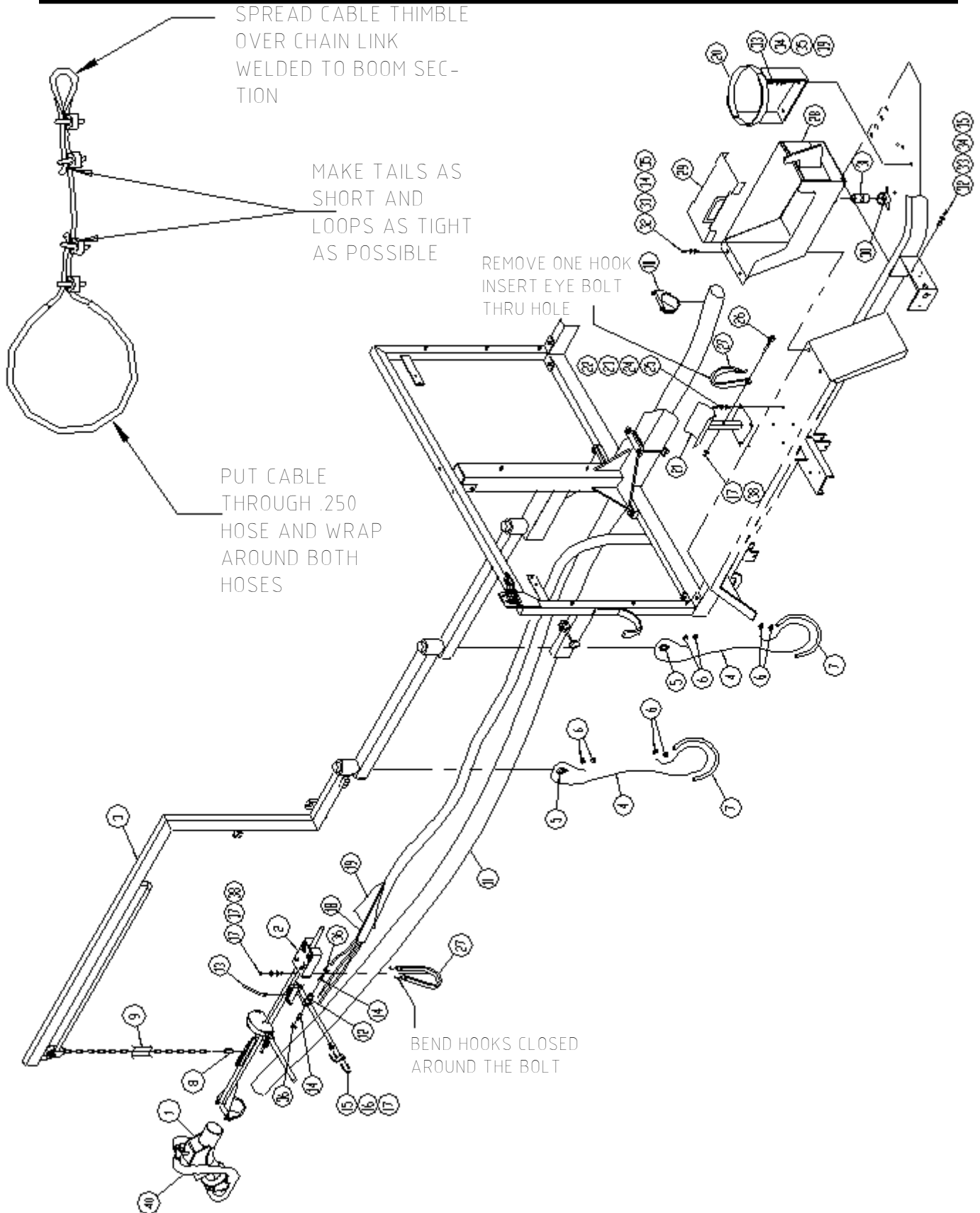

NOZZLE GROUP

ROSCO RA-2000 Patcher

STANDARD EQUIPMENT

REF: 25599

REV: G

ITEM	PART NO.	QTY.	DESCRIPTION
1	24594-063	2.00	NOZZLE,EMULSION SPRAY,.063
2	25598	1.00	NOZZLE W/M,RA2000
3	31046	5.00	FITT,STR 08MP-08HB,PUSH-ON
4	33163	7.00	CLAMP,HOSE,.50-.91,WORM,#08
5	33328	2.00	FITT,90 08MP-08HB,CRIMPED
6	99526	2.00	PIPE,90,08MP-O8FP,MI
7	99596	5.00	PIPE,NIPPLE,08XCLOSE
8	99985	2.00	PIPE,BUSH,12MP-08FP,STL
9	36622	3.00	VLV,BALL,08 NPT,T HANDLE
10	34393	2.00	VLV,CHECK
11	99662	2.00	PIPE,NIPPLE,08X2.50
12	99512	2.00	PIPE,90,08FP,MI
13	99519	1.00	PIPE,45,08MP-08FP,MI
14	24594-078	2.00	NOZZLE,EMULSION SPRAY,.078
15	6352	1.00	HOSE,08,PUSH-ON,250
16	37002	4.00	SLEEVE,ABRASION,NYLON,3.20ID
17	36664	4.00	INSULATION,TUBE,1.62IDx.38WALL
19	99537	1.00	PIPE,PLUG,08MP,SQ HD,MI

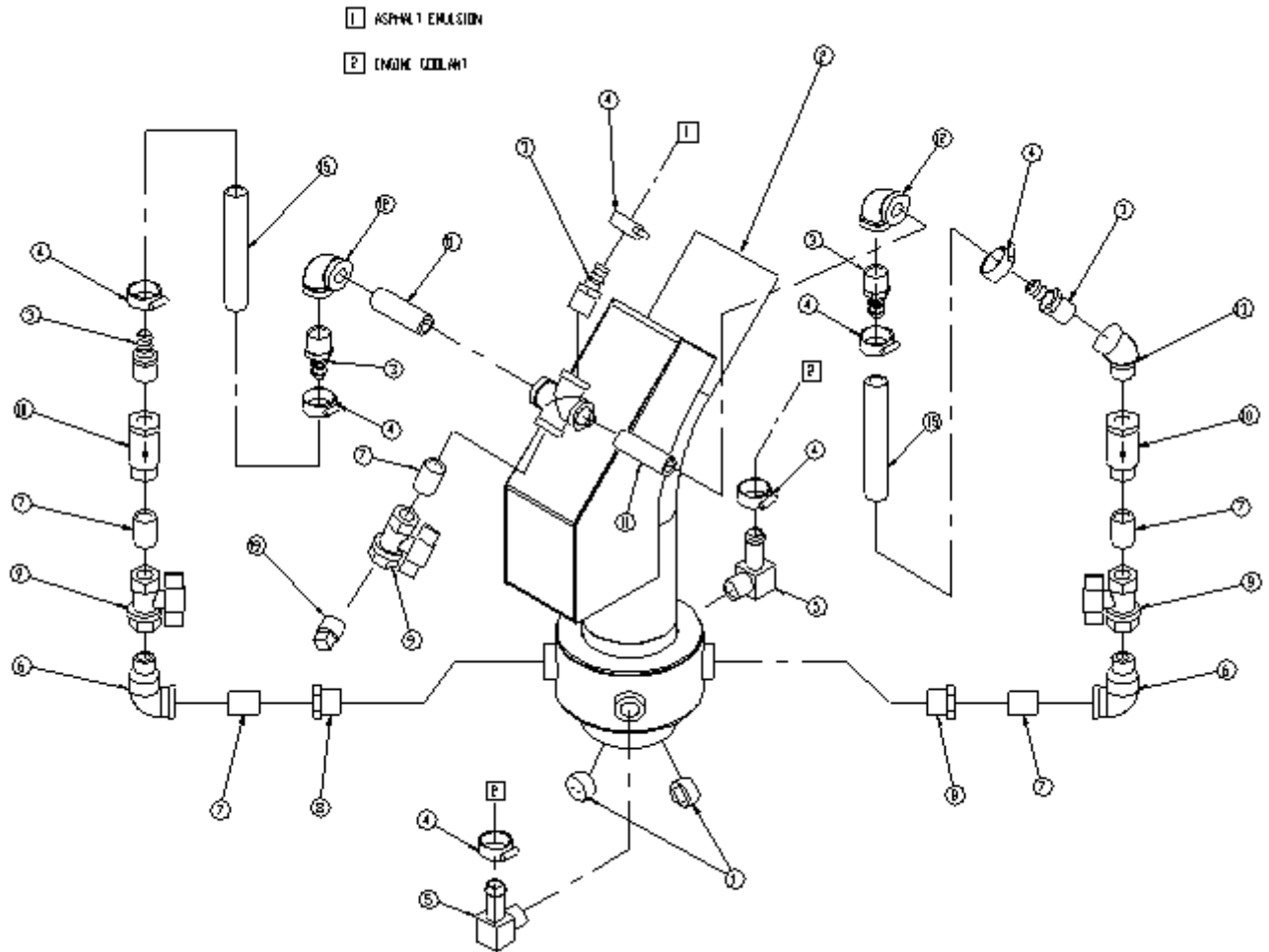

BOOM CONTROL GROUP

ROSCO RA-2000 Patcher

STANDARD EQUIPMENT

REF: 25604

REV: E

ITEM	PART NO.	QTY.	DESCRIPTION
1	25601	1.00	W/M,CONTROL HANDLE
3	80140	12.00	WASHER,TYPE A PLAIN,.250
4	80350	5.00	NUT,FLEXLOC,.250-20,FULL,LT
5	80195	5.00	CSHH,.250-20X1.75,GR5
6	80878	2.00	CRG BOLT,.250-20X.75,GR5
7	33270	2.00	NUT,WING,.250-20
8	27704	1.00	BOOM CONTROL,BOX ASSY
19	37379	1.00	PIN,QUICK RELEASE,.25X1.3 GRIP
20	847170503	.33	CHAIN,SASH,#35,STEEL
21	37371	1.00	HOOK,S,.120WIRE,.50EYE,1.74LG
23	25596	1.00	ROD,BOOM CONTROL

BOOM SUB-ASSEMBLY GROUP

ROSCO RA-2000 Patcher

STANDARD EQUIPMENT

REF: 25783

REV: B

ITEM	PART NO.	QTY.	DESCRIPTION
1	27691	1.00	MAST,BOOM,1.75 SPINDLE
2	25610	2.00	PLATE,U-BOLT,.56X5.50 CENTERS
3	71653	4.00	CSHH,.500-13X7.00,GR5
4	80040	4.00	NUT,HEX,.500-13
5	80164	4.00	WASHER,SPLIT LOCK,.500
6	25473	1.00	BOOM,FIRST SECTION
7	25471	1.00	BOOM,END SECTION
8	35332-01	2.00	BEARING REPLACEMENT SET 1.375X
9	91210	.25	GREASE,WHEEL BEARING
10	33684	3.00	FITT,LUBE,STR,02MP,SHORT
11	80132	3.00	NUT,HEX,CASTLE,.875-14
12	81059	3.00	WASHER,SAE PLAIN,.875
13	25631	1.00	REAR FRAME W/M
14	71617	4.00	CSHH,.375-16X5.00,GR5
15	80506	1.00	CSHH,.375-16X5.50,GR5
16	80038	5.00	NUT,HEX,.375-16
17	80162	5.00	WASHER,SPLIT LOCK,.375
18	6066	1.00	NUT,WING,.50-13
19	8530	1.00	EYE BOLT,LOCKING,MANHOLE COVER
20	80208	4.00	CSHH,.312-18X1.00,GR5
21	80037	4.00	NUT,HEX,.312-18
22	80141	4.00	WASHER,TYPE A PLAIN,.312
23	80161	4.00	WASHER,SPLIT LOCK,.312
24	20115	1.00	HOSE SUPPORT W/M
25	17371	1.00	ROLLER,VCUT,ASSY,S/B GUIDE
26	80261	1.00	CSHH,.500-13X2.50,GR5
27	80255	1.00	CSHH,.500-13X2.00,GR5
28	80354	2.00	NUT,FLEXLOC,.500-13,FULL,LT
29	27694	1.00	BOOM,SECTION,1.75 HUB
30	31226	1.00	BEARING,CONE AP04503-001,1.75I
31	31227	1.00	BEARING,CUP,INNER
32	31713	1.00	NUT,6BF SPINDLE
33	31721	1.00	BEARING,CONE,1.25ID
34	33187	1.00	SEAL,GREASE,2.25ID,3.75OD,SLG
35	38303-04	1.00	OUTER RACE
36	38498	1.00	DUST CAP
37	80149	1.00	WASHER,TYPE A PLAIN,1.000

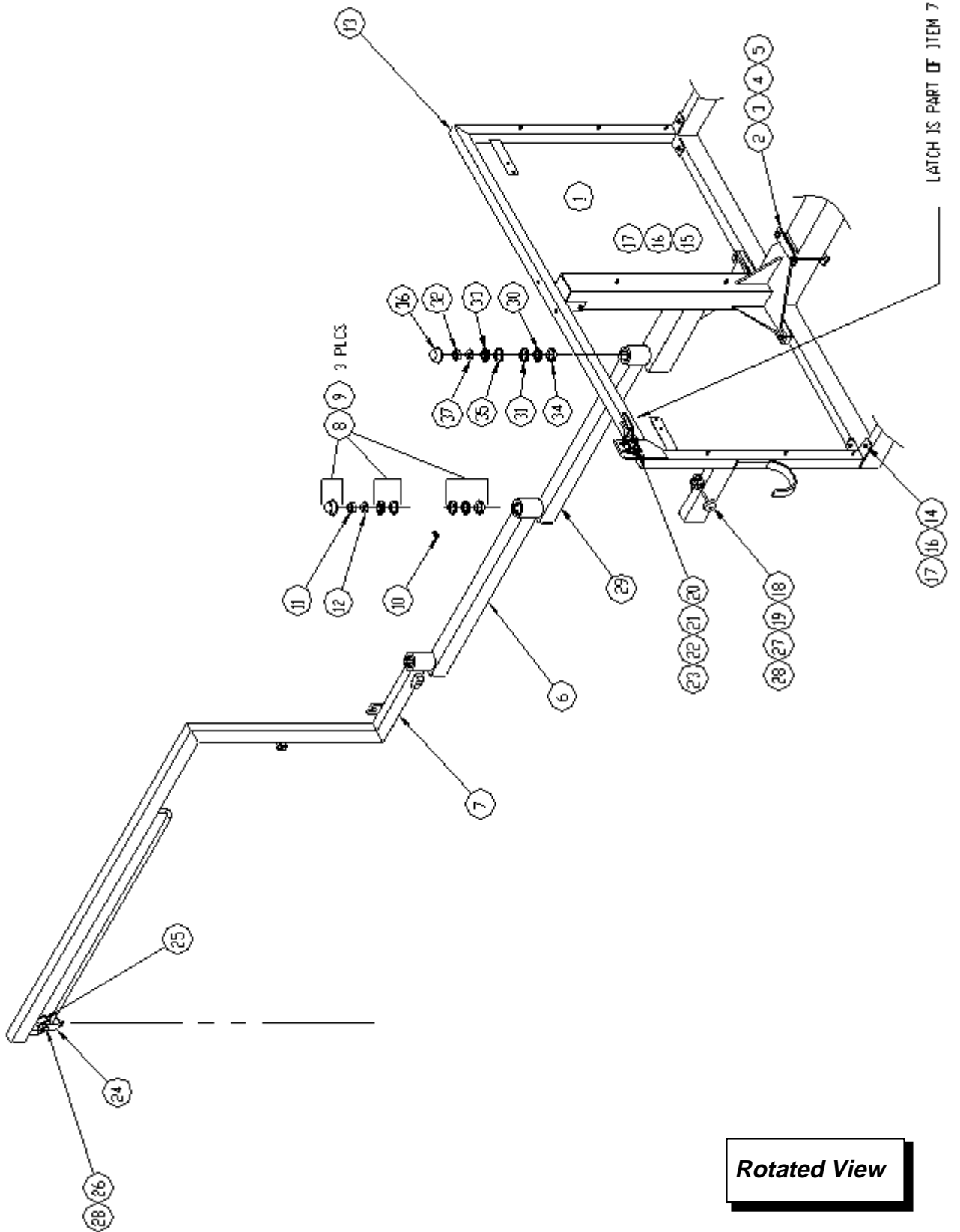

FUEL & FLUSH GROUP

ROSCO RA-2000 Patcher

STANDARD EQUIPMENT

REF: 25443

REV: G

ITEM	PART NO.	QTY.	DESCRIPTION
1	25444	1.00	TANK W/M,FUEL/FLUSH,RA2000
2	31046	2.00	FITT,STR 08MP-08HB,PUSH-ON
3	31109	1.00	FITT,STR 08FJX-08HB,PUSH-ON
4	33117	1.00	FITT,90 04MP-04FP
5	33162	6.00	CLAMP,HOSE,.44-.78,WORM,#06
6	35266	1.00	FITT,STR 04MP-03HB,CRIMPED
7	36043	1.00	FITT,45 08MJ-08FJX
8	34181-01	2.00	GAUGE,LIQUID LEVEL 12 O'CLOCK
9	36305	1.00	PIPE,TEE,08MP-08FP-08FP,STL
10	36886	1.00	VLV,CHECK 06HB,POLY (1PSI)
11	37680	2.00	FILLER,HYD FLUID,10 PSI
12	37914	1.00	PUMP,MOTOR,3GPM,12VDC,100PSI
13	6352	4.00	HOSE,08,PUSH-ON,250
14	6410	1.00	FITT,90 08MJ-08MB
15	71717	10.00	MACH SCR,PH,#10-32X.75
16	71814	7.50	HOSE,03,PUSH-ON,.250
17	80142	4.00	WASHER,TYPE A PLAIN,.375
19	80230	2.00	CSHH,.375-16X2.00,GR5
20	81155	2.00	WASHER,SAE,HARDENED,.375
21	871071601	10.00	WASHER,SPLIT LOCK,#10
22	99535	1.00	PIPE,PLUG,04MP,SQ HD,MI
23	99537	2.00	PIPE,PLUG,08MP,SQ HD,MI
24	X216	2.00	FITT,STR 06FJX-06HB,PUSH-ON
25	X304	1.00	FITT,90 06MP-06HB,CRIMPED
26	X341	14.00	HOSE,06,PUSH-ON,250,BLUE
29	80351	4.00	NUT,FLEXLOC,.312-18,FULL,LT
30	37903	1.00	FITT,TEST 08FJ-02PD
31	33938	1.00	FITT,TEE 08MJ-08MJ-08FJX
32	35194	1.00	FITT,STR 08MJ-06MB
33	33898	1.00	FITT,TEE 08MJ-08FJX-08MJ
34	36103	1.00	FITT,STR 08MP-08FJ
35	38023	1.00	STRAINER,Y,08FP,100 MESH
36	38104	1.00	FITT,STR 08FJ-08FP
37	5499	1.00	VLV,DRAIN .25
38	99535	1.00	PIPE,PLUG,04MP,SQ HD,MI
39	99980	1.00	PIPE,BUSH,08MP-04FP,STL
40	71839	8.50	WIRE,6 GA,BLK
41	71859	2.00	TERM,RING,6 GA,.375 STUD
42	36894	2.00	CLAMP,LOOP,2.00 OD,PLSTC COVER
43	80350	2.00	NUT,FLEXLOC,.250-20,FULL,LT
44	80140	2.00	WASHER,TYPE A PLAIN,.250
45	35786	4.00	CLAMP,DOUBLE TUBE,.75 ID

ROSCO RA-2000 Patcher

REF: 25443

REV: G

FUEL & FLUSH GROUP

STANDARD EQUIPMENT

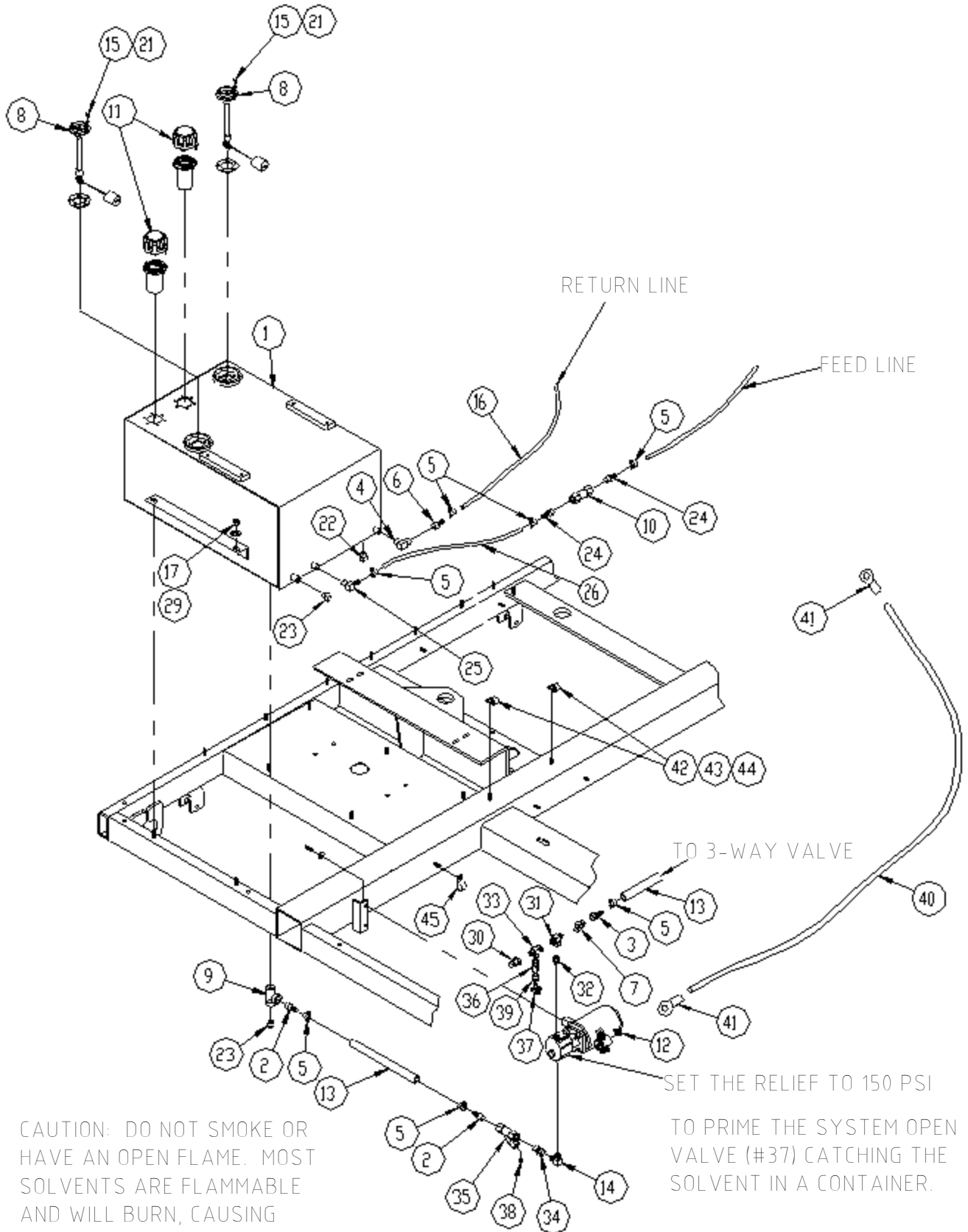

CAUTION: DO NOT SMOKE OR HAVE AN OPEN FLAME. MOST SOLVENTS ARE FLAMMABLE AND WILL BURN, CAUSING SERIOUS INJURY.

SET THE RELIEF TO 150 PSI TO PRIME THE SYSTEM OPEN VALVE (#37) CATCHING THE SOLVENT IN A CONTAINER.

COMPRESSED AIR GROUP

ROSCO RA-2000 Patcher

STANDARD EQUIPMENT

REF: 27721

REV: B

ITEM	PART NO.	QTY.	DESCRIPTION
1	33086	1.00	FITT,STR 04MJ-04MP
2	33162	7.00	CLAMP,HOSE,.44-.78,WORM,#06
3	33365	3.00	FITT,90 04MP-06HB,CRIMPED
4	33588	1.00	VLV,BALL,06 NPT
5	33750	1.00	VLV,AIR,SAFETY,125PSI,04 NPT
6	33900	1.00	FITT,90 08MJ-08FJX
7	34082	1.00	FITT,STR 06MJ-08MP
8	35435	1.00	AIR PRESS REGULATOR 5-125 PSIG
9	35556	1.00	FITT,STR 06MP-06FJX
10	35597	1.00	VLV,AIR,SOL,2POS,5PORT,.02
11	36305	1.00	PIPE,TEE,08MP-08FP-08FP,STL
12	36656	1.00	GAUGE,PRESS,0-160 PSI,2.5 OD
14	37409-060	1.00	HOSE,04 04FJX-04FJ90,180 OS
15	38039-072	1.00	HOSE,08 08FJX-08FJX,TEFLON
16	38070	1.00	DRAIN COCK,CABLE PULL,1/4 NPT
17	38674	1.00	FITT,45 08MJ-08MP
18	72529	2.00	BREATHER,04-MP
19	72649	1.00	FITT,STR 04MJ-02MP
20	72828	1.00	AIR RSVR,9.50X22.50,1488 CU IN
21	99450	3.00	PIPE,BUSH,08MP-06FP,MI
22	99490	2.00	PIPE,CPLG,04FP
23	99496	1.00	PIPE,CROSS,04FP,MI
24	99523	1.00	PIPE,90,02MP-02FP,MI
25	99545	1.00	PIPE,PLUG,12MP,SKT HD,MI
26	99591	3.00	PIPE,NIPPLE,04XCLOSE(7/8)
27	99638	1.00	PIPE,NIPPLE,06XCLOSE
28	X304	4.00	FITT,90 06MP-06HB,CRIMPED
29	X341	17.00	HOSE,06,PUSH-ON,250,BLUE
30	36496	1.00	FITT,STR 08MJ-12MP
31	80038	4.00	NUT,HEX,.375-16
32	80221	4.00	CSHH,.375-16X1.00,GR5
33	80493	2.00	NUT,HEX,#6-32
34	80996	8.00	WASHER,SAE PLAIN,.375
35	81188	2.00	WASHER,TYPE A PLAIN,#6
36	81205	2.00	MACH SCR,PH,#6-32 X 1.50
37	80928	2.00	CSHH,M8X1.25X75,CL8.8
38	80477	2.00	WASHER,SPLIT LOCK,M8
39	80141	2.00	WASHER,TYPE A PLAIN,.312

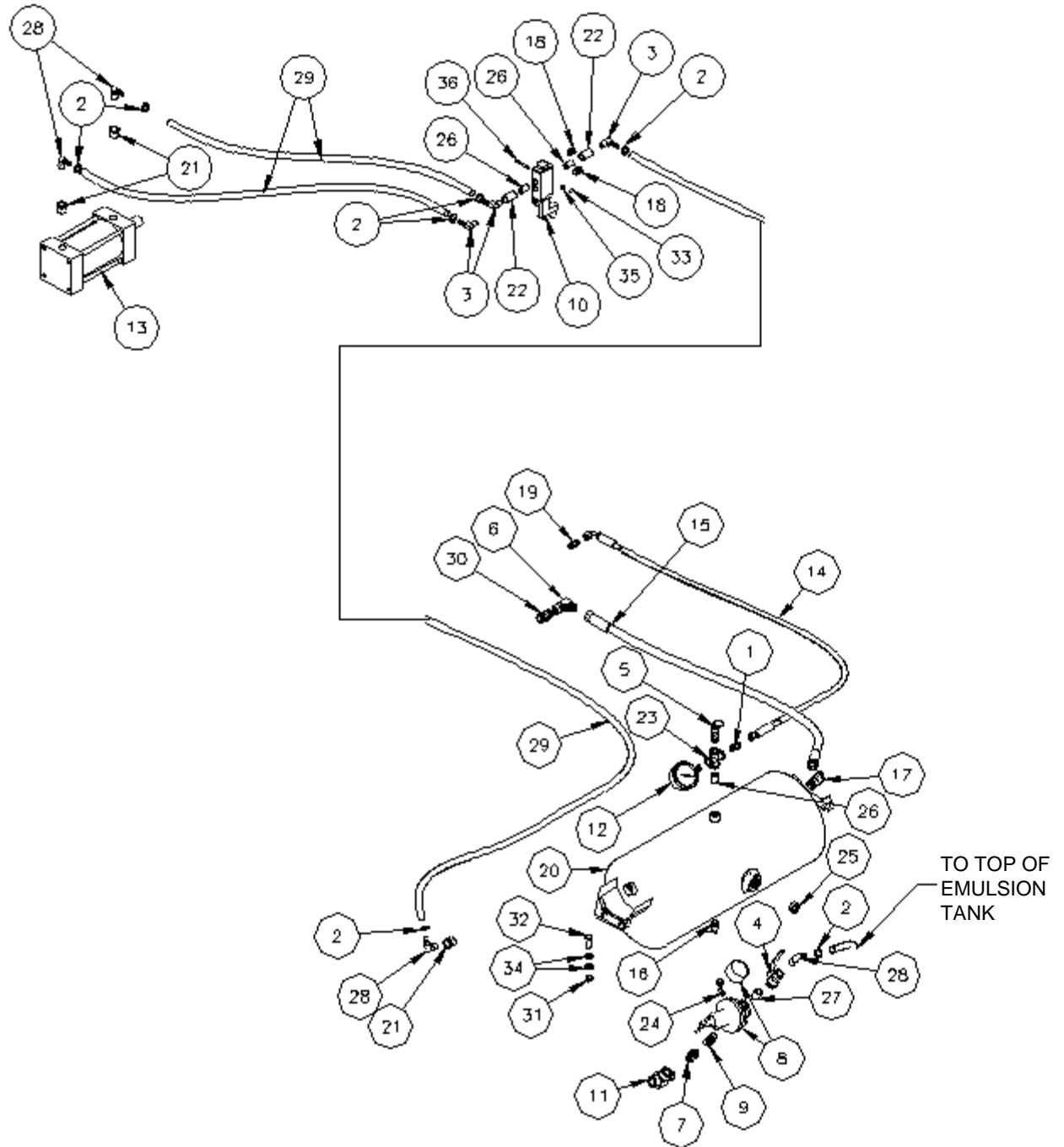

ENGINE COVER ASSEMBLY

ROSCO RA-2000 Patcher

STANDARD EQUIPMENT

REF: 26818

REV: B

ITEM	PART NO.	QTY.	DESCRIPTION
1	26819	1.00	PANEL,LEFT
2	26820	1.00	PANEL,RIGHT
3	25326	1.00	PANEL,HOOD,REAR
4	26822	1.00	PANEL,FRONT
5	26823	1.00	W/M,REAR PANEL
6	26829	1.00	W/M,FRONT HOOD
7	25337	1.00	ROD W/M,PROP
8	25344	1.00	HINGE,ENGINE PANEL ASSEMBLY
9	25345	1.00	PANEL,LOUVRE MOUNT,LH
10	26835	1.00	PANEL,LOUVRE MOUNT,RH
11	25347	1.00	LOUVRE, TOP
12	25348	4.00	BRACKET,GAS SPRING
13	25349	5.00	LOUVRE, BOTTOM
14	26836	1.00	PLATE,REAR,LOWER
15	25351	1.00	PLATE,REAR,UPPER
16	6080	1.00	SWITCH,MERCURY
17	35244	20.00	STRIP,ADH SPONGE,.75X.062
18	37972	4.00	FITT,METAL BALL SOCKET,13MM
19	37973	4.00	STUD,BALL,5/16-18
20	37974	4.00	SAFETY CLIP,13MM
21	37980	2.00	LATCH,DRAW
22	38005	2.00	CYLINDER,GAS SPRING,150#
23	9963	1.00	BRACKET,MERCURY SWITCH
24	71716	4.00	MACH SCR,PH,#10-24X.75
25	71766	1.00	HANDLE,6.00
26	80995	4.00	WASHER,TYPE A PLAIN,#10
27	81005	4.00	NUT,FLEXLOC,#10-24,FULL,LT
28	90970	15.00	SEAL,TRIM,PUSH-ON,RUB,.063GRIP
29	26838	1.00	FOAM,SOUND BARRIER,RA2000
30	26861	1.00	BRACKET,SUPPORT
31	27063	1.00	W/M,FLOOR PLATE
34	37983	1.00	DECAL,WARNING,PINCH HAZARD
36	22814	1.00	SWITCH SUPPORT W/M
37	80307	1.00	SET S,SQ,CUP,.250-20X.50
38	33271-2	6.00	WIRE,16 GA,YELLOW
39	33271-13	6.00	WIRE,16 GA,BLACK/YELLOW STRIPE
40	33602	2.00	CONN,BUTT,16-14 GA
41	35138	1.00	CONNECTOR,SEALED,SHROUD,2-PIN
42	36164	2.00	TERM,SEALED CONN,16-14 GA,MALE
43	36166	2.00	SEAL,CABLE,18-16 GA
44	71060	6.00	LOOM,SPLIT,CONVOLUTED,.250
45	80140	189.00	WASHER,TYPE A PLAIN,.250
46	80141	18.00	WASHER,TYPE A PLAIN,.312
47	80160	103.00	WASHER,SPLIT LOCK,.250
48	80192	96.00	CSHH,.250-20X.75,GR5
49	80036	30.00	NUT,HEX,.250-20

NOTE:

1. ONCE HOOD PARTS #3 & #6 ARE ASSEMBLED APPLY SEAL #28 TO FLANGE IN A CONTINUOUS STRIP.
2. APPLY FOAM #29 TO PARTS PER DRAWING 25453.

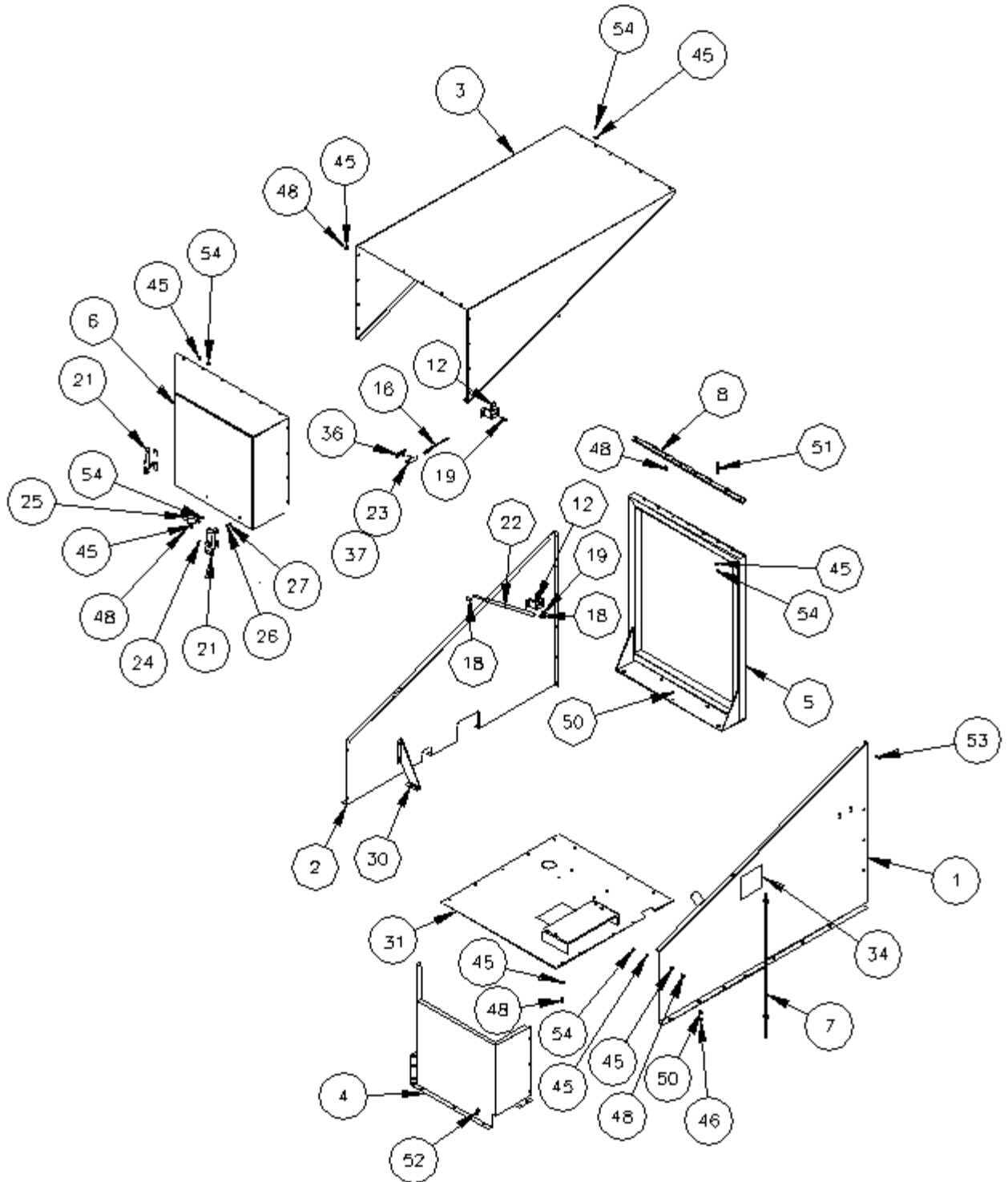

ENGINE COVER ASSEMBLY

ROSCO RA-2000 Patcher

STANDARD EQUIPMENT

REF: 26818

REV: B

ITEM	PART NO.	QTY.	DESCRIPTION
50	80351	9.00	NUT,FLEXLOC,,312-18,FULL,LT
51	80787	7.00	CSHH,.250-20X2.50,GR5
52	80208	9.00	CSHH,.312-18X1.00,GR5
53	81160	38.00	SCR,SLFDRL,HH,#10X1.00,#3PT
54	80350	103.00	NUT,FLEXLOC,.250-20,FULL,LT

LATCH INSTALLATION INSTRUCTIONS:

1. Attach keeper from #21 to hood #6 with hardware shown in assy on sheet one.
2. Complete assy as shown except for latch #21.
3. While hood is closed, apply weight to the top of the hood to assure proper closure.
4. Refer to drawing for location of latch.
5. Attach latch #21 to panel #4 with #34 self-drilling screws.

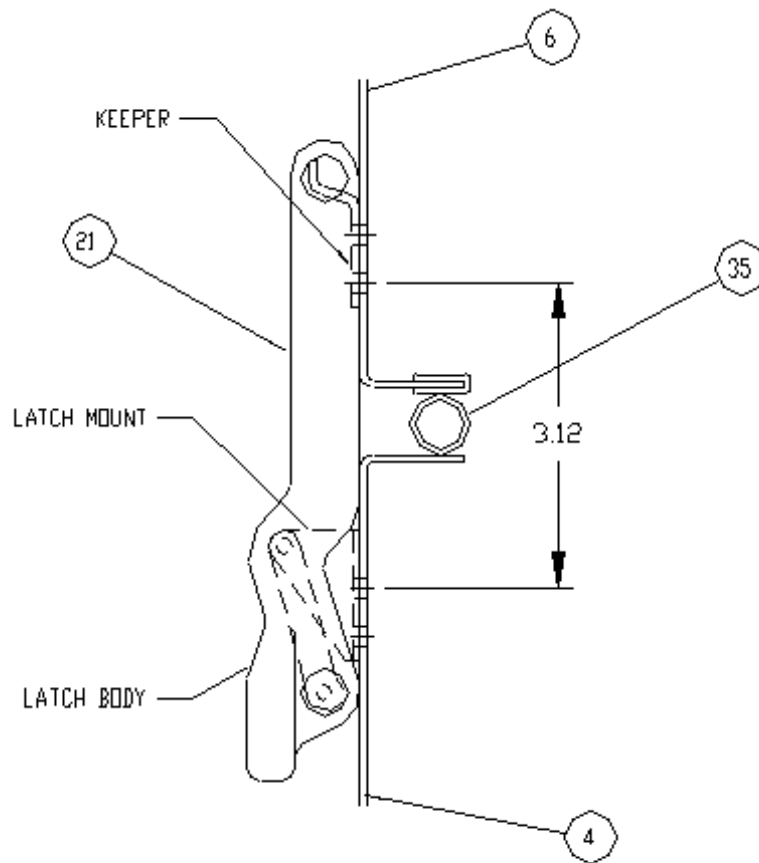

LATCH INSTALLATION

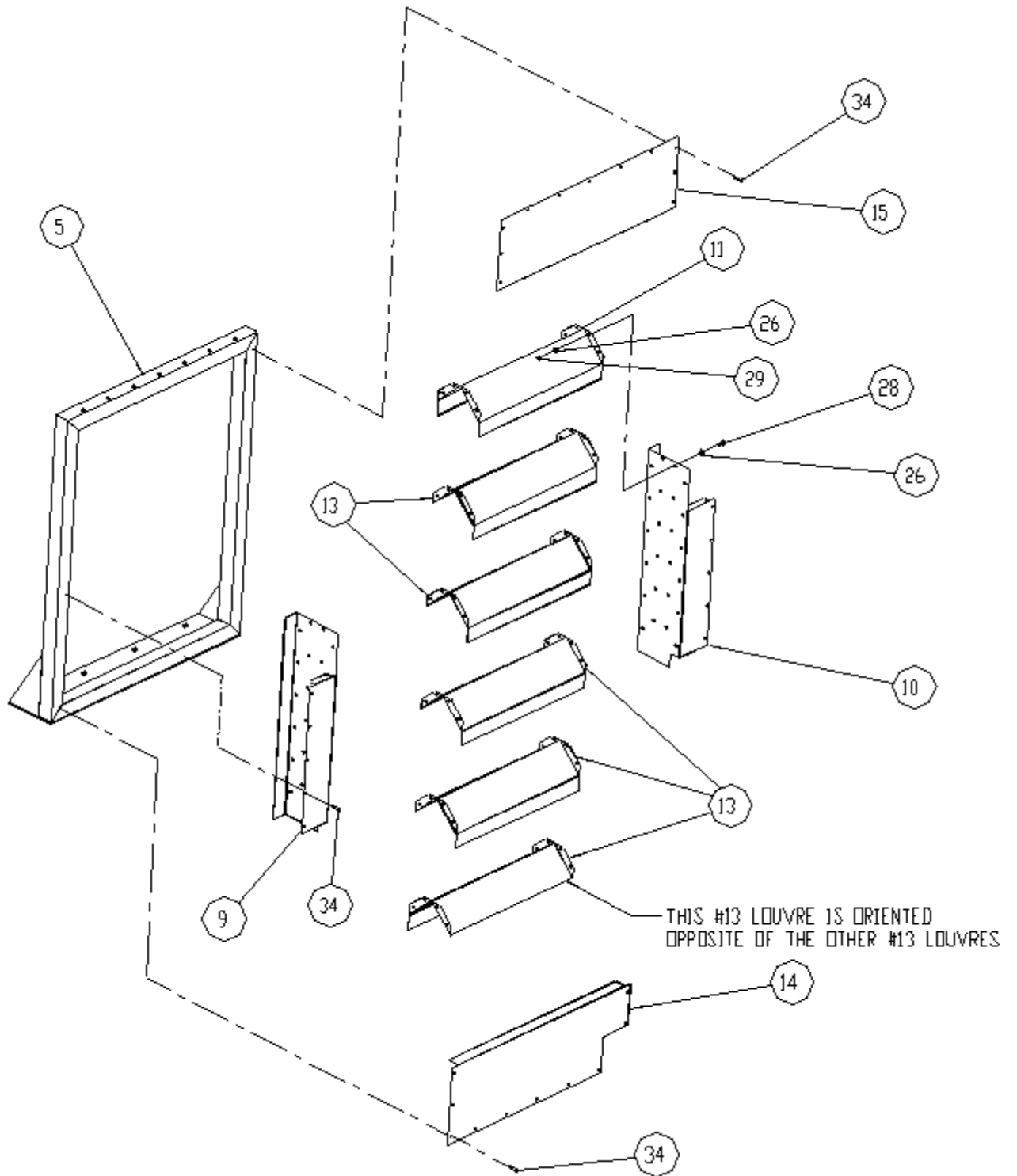

LOUVRE AND REAR PANEL ASSEMBLY

FINAL GROUP

ROSCO RA-2000 Patcher

STANDARD EQUIPMENT

REF: 25668

REV: G

ITEM	PART NO.	QTY.	DESCRIPTION
4	22084	4.00	LIGHT,CLEARANCE,AMBER,MODIFIED
5	35663	1.00	LIGHT BAR,RED,KD502
6	22085	1.00	LIGHT,TAIL,RH,MODIFIED
7	22086	1.00	LIGHT,TAIL,LH,MODIFIED
8	22154	2.00	GRATING,STEP,RA200
10	22464	1.00	HANDLE,GRAB,W/M,RA200
11	27595	1.00	HITCH,ADJUSTABLE TONGUE,W/M
12	33630	2.50	STRIPPING,.062
13	37053	4.00	ANCHOR,STEP GRATING
14	37094	1.00	BRACKET,LICENSE PLATE
15	81160	2.00	SCR,SLFDRL,HH,#10X1.00,#3PT
16	71717	14.00	MACH SCR,PH,#10-32X.75
17	80141	29.00	WASHER,TYPE A PLAIN,.312
18	80208	18.00	CSHH,.312-18X1.00,GR5
19	80212	3.00	CSHH,.312-18X2.00,GR5
20	80351	35.00	NUT,FLEXLOC,.312-18,FULL,LT
21	80494	14.00	NUT,HEX,#10-32
24	81129	14.00	CRG BOLT,.312-18X2.50,GR5
26	871071601	14.00	WASHER,SPLIT LOCK,#10
27	91156	3.50	PAINT,CAT 1 YELLOW,ACRYLIC
28	90533-01	1.00	PAINT,ROSCO YELLOW,TOUCH-UP
29	38074	2.00	GRIP,VINYL,.88ID,4.75LG,BLACK
30	72125	1.00	GRIP,HANDLE .125X2.75,FLAT
31	80982	2.00	CSHH,.625-11X4.00,GR8
32	80146	4.00	WASHER,TYPE A PLAIN,.625
33	80042	4.00	NUT,HEX,.625-11
34	80166	6.00	WASHER,SPLIT LOCK,.625
35	81055	2.00	CSHH,.625-11X4.50,GR8
36	80356	2.00	NUT,FLEXLOC,.625-11,FULL,LT
37	80697	4.00	WASHER,SAE PLAIN,.625

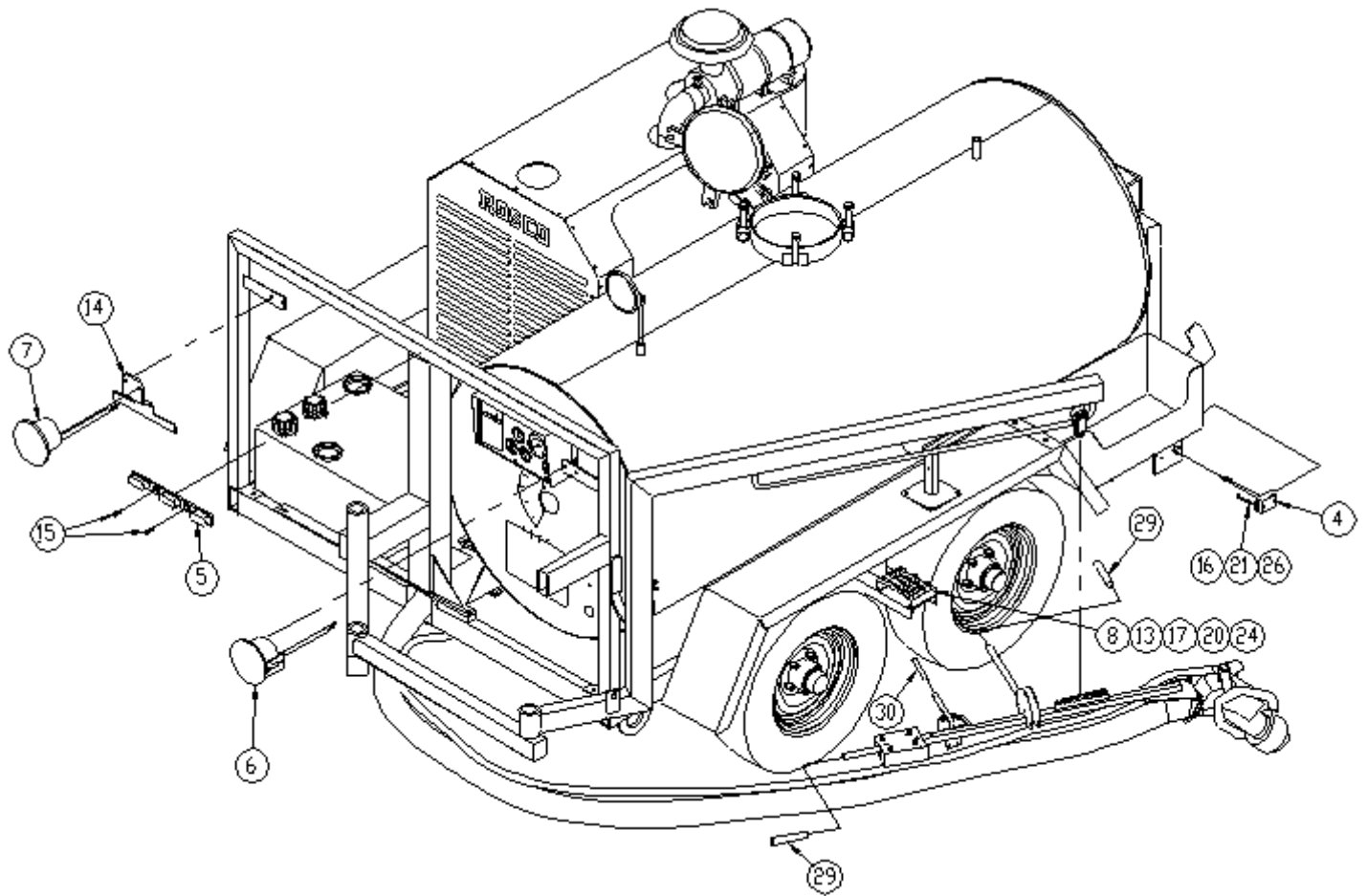

NON-ILLUSTRATED GROUP**ROSCO RA-2000 Patcher**

STANDARD EQUIPMENT

REF: SEE BELOW

REV:

ITEM	PART NO.	QTY.	DESCRIPTION
	25784	1.00	STROBE LIGHT
1	25779	1.00	MOUNTING BRACKET,STROBE LIGHT
3	71716	3.00	MACH SCR,PH,#10-24X.75
2	38233	1.00	LIGHT,AMBER STROBE
6	80038	2.00	NUT,HEX,.375-16
7	80162	2.00	WASHER,SPLIT LOCK,.375
5	80232	2.00	CSHH,.375-16X2.50,GR5
4	80924	3.00	NUT,FLEXLOC,#10-24,FULL,LT
8	6322	1.00	SWITCH,PUSH-PULL,ON/OFF,12V
9	35230	1.00	DECAL,BEACON

35484-01 1.00 LUNETTE EYE,3" (7.62cm),ADJUSTABLE

CRACK FILLING GROUP

ROSCO RA-2000 Patcher

OPTIONAL EQUIPMENT

REF: 25866

REV: A

ITEM	PART NO.	QTY.	DESCRIPTION
1	13974	1.00	HANDSPRAY GUN ASSY ASP (See Detail)
2	27023	1.00	PLATE,HOSE REEL MOUNT
3	32874	1.00	VLV,BALL,08-BRASS
4	34153	1.00	HOSE REEL-RETRACT,W/RATCHET ST
5	34154	1.00	HOSE STOP (.43 TO .75 O.D.)
6	35548	1.00	HOSE,08X300,08M(2),1750
7	6352	5.00	HOSE,08,PUSH-ON,250
8	31046	2.00	FITT,STR 08MP-08HB,PUSH-ON
9	6469	1.00	FITT,STR 08MP-08FPX
10	80142	8.00	WASHER,TYPE A PLAIN,.375
11	80162	8.00	WASHER,SPLIT LOCK,.375
12	80226	4.00	CSHH,.375-16X1.50,GR5
13	80038	4.00	NUT,HEX,.375-16
14	99569	1.00	PIPE,TEE,08FP,MI
15	99596	2.00	PIPE,NIPPLE,08XCLOSE
16	33163	2.00	CLAMP,HOSE,.50-.91,WORM,#08
17	25879	1.00	BRACKET,WAND
18	25880	1.00	BRACKET,WAND
19	81160	6.00	SCR,SLFDRL,HH,#10X1.00,#3PT
20	71622	4.00	CSHH,.375-16X.875,GR5

	13974	REV.B	HANDSPRAY GUN ASSEMBLY
A	10126	1.00	HANDLE ASSY, HANDSPRAY GUN
B	11056	1.00	HANDSPRAY PIPE,ALUM
C	1557	1.00	HANDLE,HAND SPRAY
D	19606	1.00	VLV,HANDSPRAY,.50,W/HANDLE
E	80000	1.00	NUT,HEX,.250-20,GR2
F	80188	1.00	CSHH,.250-20X5.50,GR5
G	80219	1.00	CSHH,.375-16X.75,GR5
H	99835	1.00	PIPE,45,08FP,GAL
I	X144	1.00	FITT,STR 08MP-06HB,CRIMPED
J	X427	1.00	FITT,STR 08MP-08HB,CRIMPED

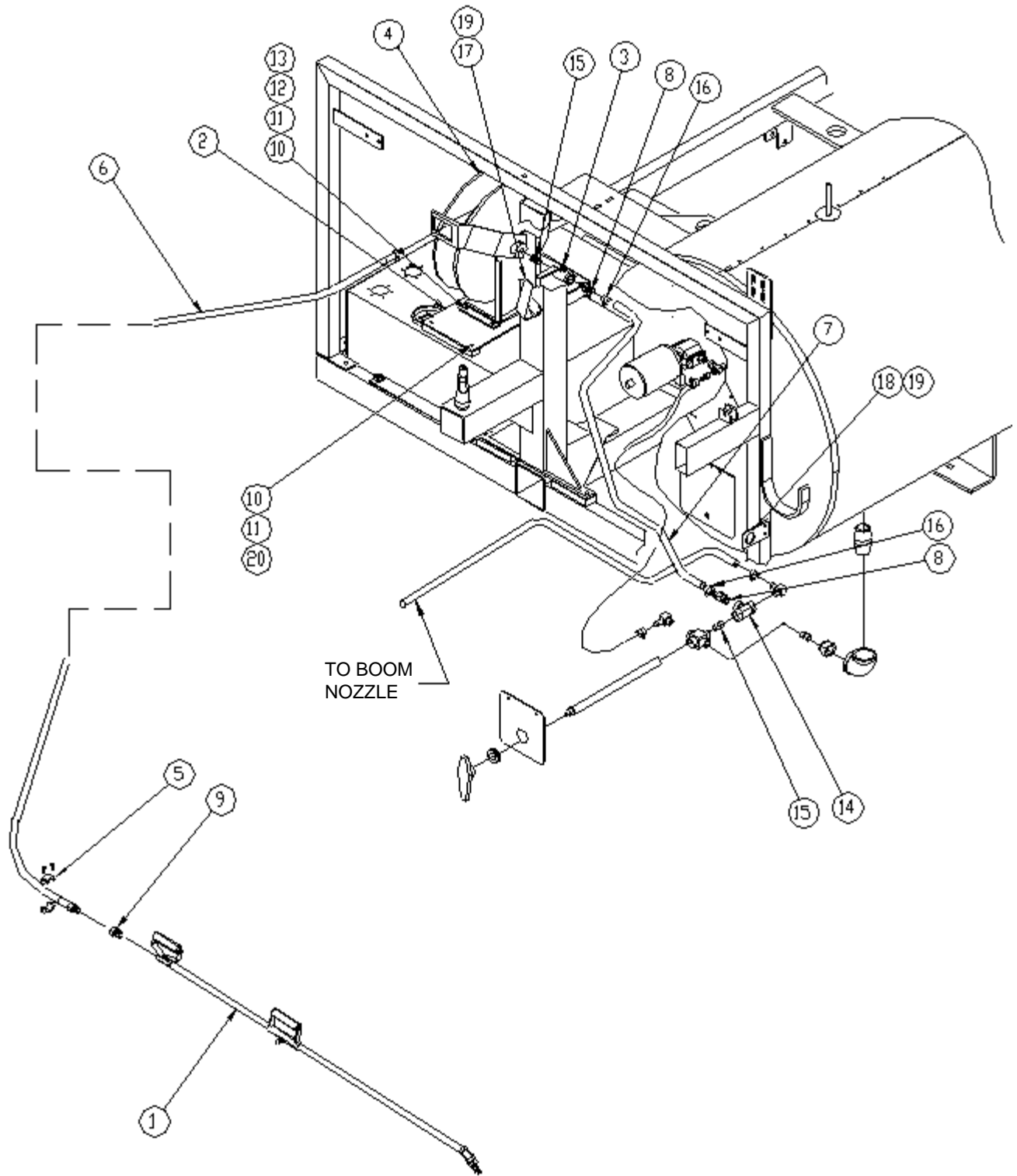

FILL STRAINER

ROSCO RA-2000 Patcher

OPTIONAL EQUIPMENT

REF: 23514

REV: 0

ITEM	PART NO.	QTY.	DESCRIPTION
1	35934	17.00	RIVET,BLIND,STL,.188,.020-.125
2	7362-1	1.00	BASKET,MANHOLE SCREEN
3	7362-2	1.00	BOTTOM,MANHOLE SCREEN
4	7362-3	1.00	HOOK,MANHOLE SCREEN

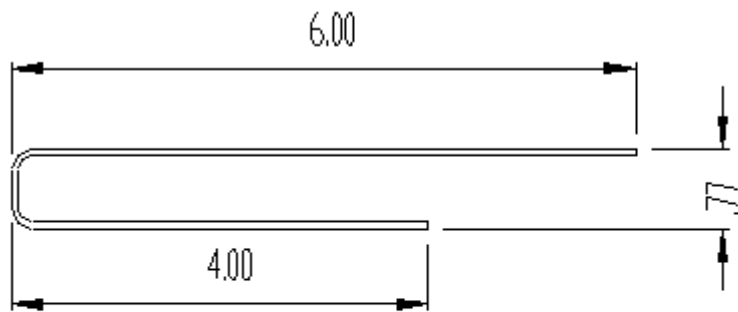

HOOK FORMED VIEW

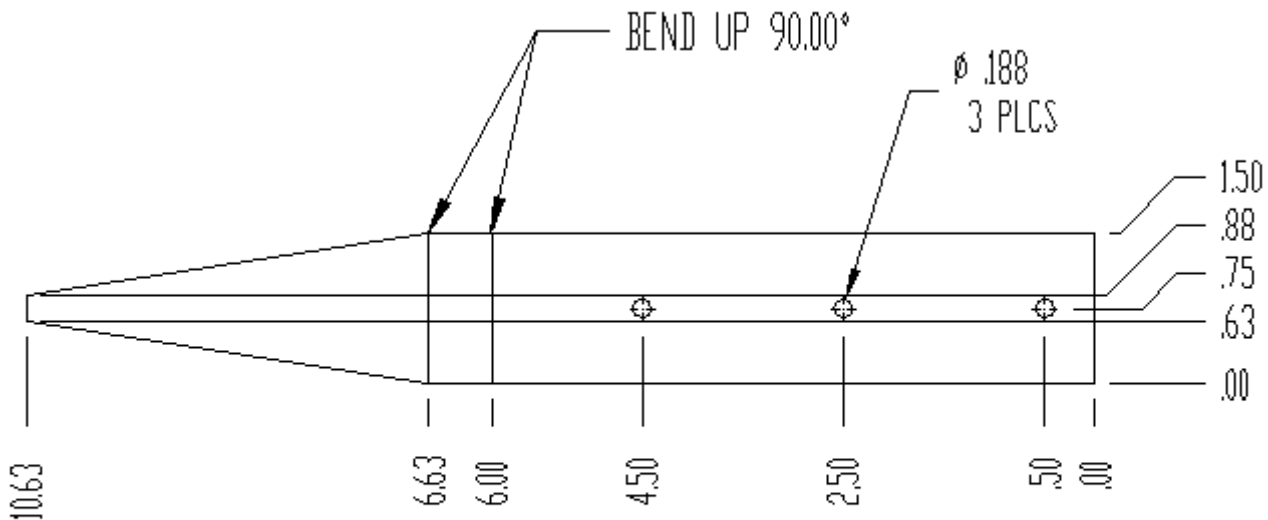

HOOK FLAT PATTERN

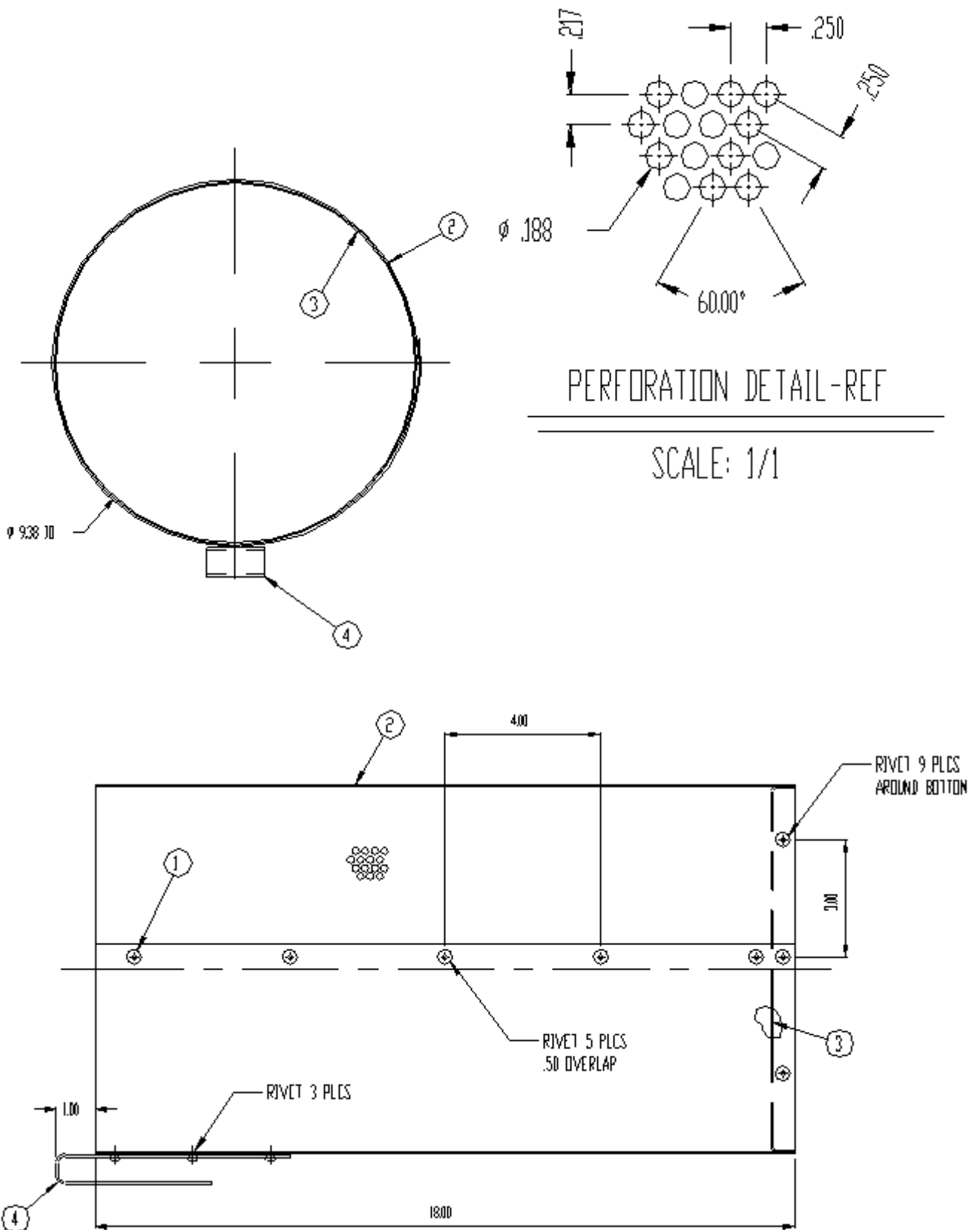

BALL HITCH

ROSCO RA-2000 Patcher

OPTIONAL EQUIPMENT

REF: 36120-01

REV: 0

ITEM	PART NO.	QTY.	DESCRIPTION
------	----------	------	-------------

MANUFACTURER: DICO, INC.
BOX 1344
DES MOINES, IA 50305
PHONE: (800) 247-1781
FAX: (515) 244-1894

DESCRIPTION: HYDRAULIC BRAKE ACTUATOR WITH
ADJUSTABLE 2 5/16" (5.874 cm) BALL HITCH

LOAD RATING: 12,000 lbs (5443 kg)

TONGUE LOAD RATING: 1,200 lbs (544 kg)

DICO PART NO.: 1889B

WEIGHT: 75 lbs (34 kg)

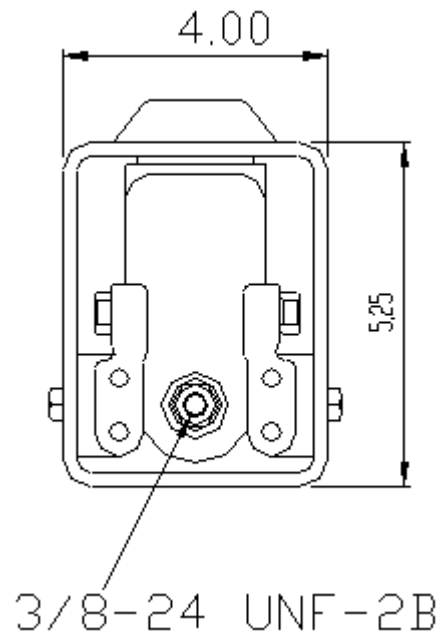

ROSCO RA-2000 Patcher

REF: 36120-01

REV: 0

BALL HITCH

OPTIONAL EQUIPMENT

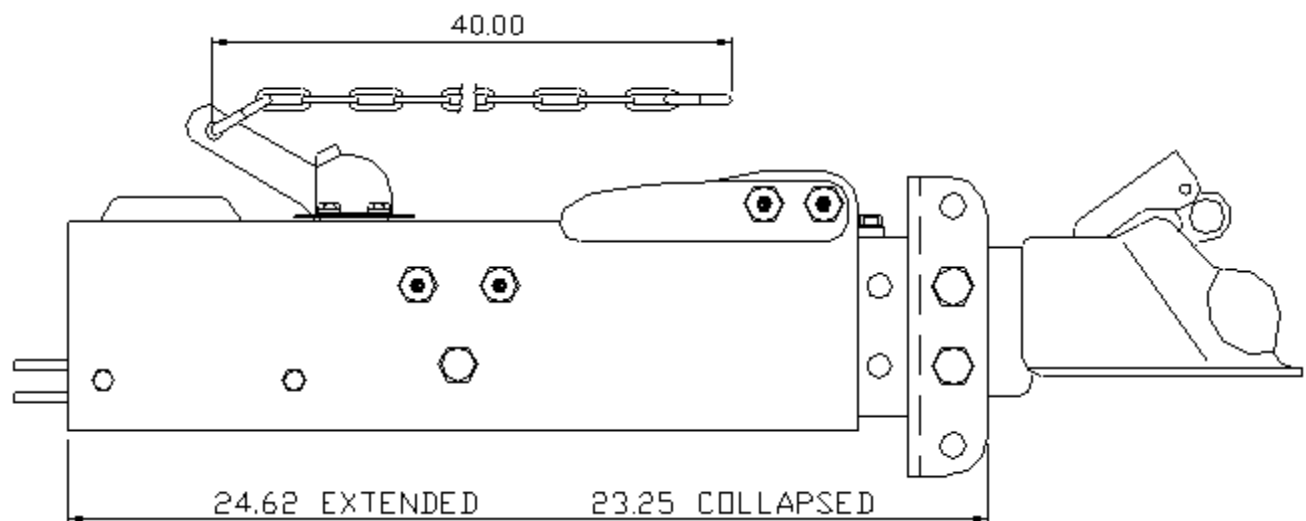
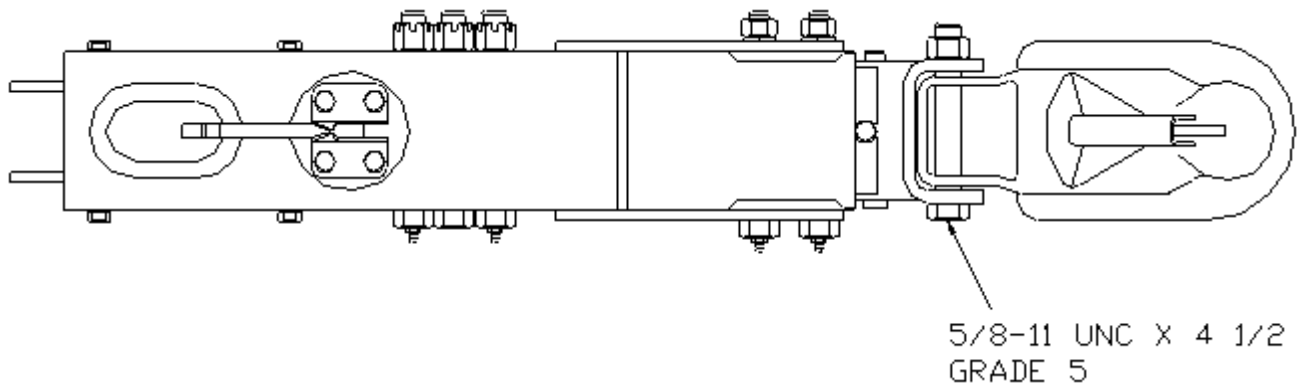

ARROW BOARD**ROSCO RA-2000 Patcher**

OPTIONAL EQUIPMENT

REF: 36504

REV: A

ITEM	PART NO.	QTY.	DESCRIPTION
1	36504-01	1.00	PANEL MOUNT FUSE HOLDER
2	36504-02	1.00	2P2T ON-OFF-ON TOGGLE SWITCH
3	36504-03	1.00	3P2T ON-OFF-ON TOGGLE SWITCH
4	36504-04	1.00	FLASHER MODUAL WITH RELAY
5	36504-05	3.00	AMBER PILOT LAMP
6	36504-06	10.00	STANDARD LAMP FOR TG-A1
7	36504-07	10.00	4" AMBER LENS FOR STD LAMP
8	36504-08	10.00	RETAINING RING FOR STD LAMP
NS	36504-09	10.00	PAPER GASKET FOR STD LAMP

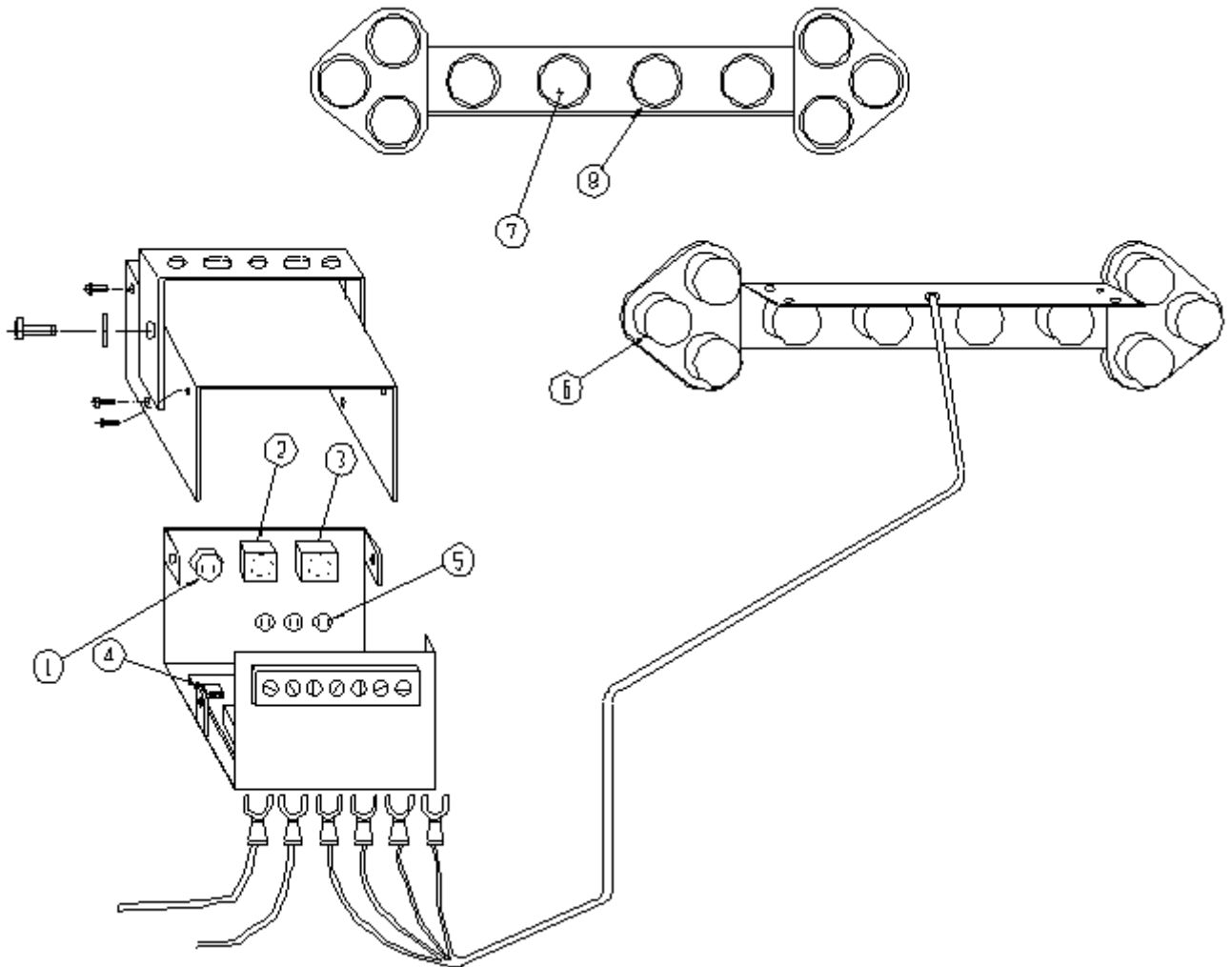

ITEM	PART NO.	QTY.	DESCRIPTION
1	37141	12.00	CORD,ELEC,3WIRE,12 GA,300V
2	37226	1.00	LIGHT,240V,.33W,RED
3	34729	9.00	CONDUIT,METAL FLEX,.50 ID
4	34732	2.00	CONNECTOR,STR,FLEX CONDUIT,.50
5	37459	2.00	ELEMENT,HEATER,2000W @ 240VAC
6	36682	1.00	THERMOSTAT,ELEC,110-170 DEG F
7	37800	1.00	RCPT,ELEC,MALE,30A,250V,FLG IN
8	37801	1.00	PLUG,ELEC,FEMALE,30A,250V
9	80496	2.00	MACH SCR,PH,#10-32X.25,PHIL
10	851390204	11.00	TERM,RING,16-14 GA,#10 STUD
11	871071601	2.00	WASHER,SPLIT LOCK,#10
12	81150	2.00	SCR,SLFTP,PH,#10X.500,AB
13	37220	1.00	DECAL,TEMP CELSIUS (FOR 36682)

PASSENGER SIDE
HEATING ELEMENT
12.8 OHMS 240 V
2000 WATTS
@240 V

WIRING DETAIL

DRIVER SIDE
HEATING
ELEMENT
12.8 OHMS
240V 2000
WATTS
@240V

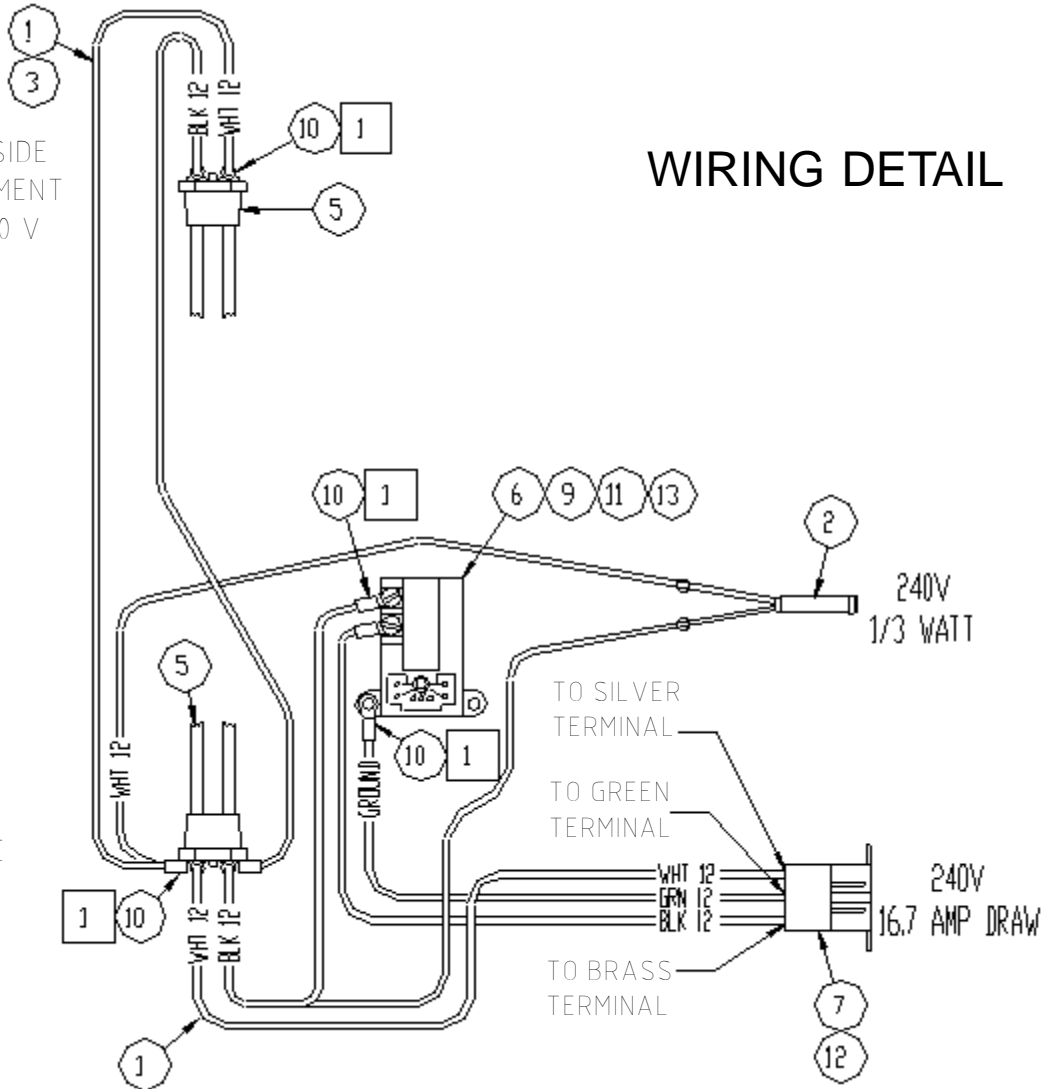

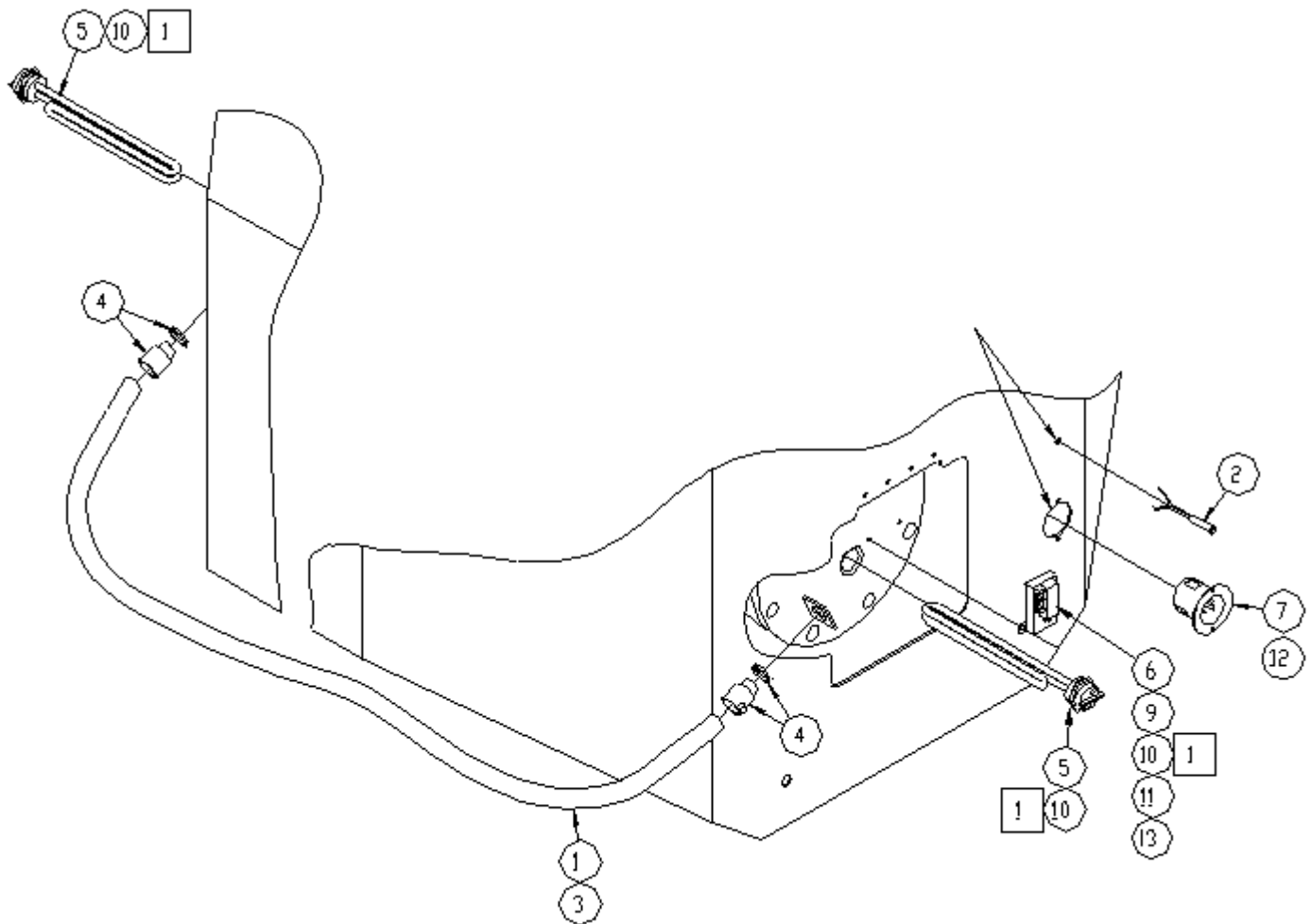

ASSEMBLY DETAIL

NOTE:

1. SILICONE ALL TERMINALS
2. PLACE PLUG (#8) IN CAB OF TRUCK

Alphabetical Parts Index

Symbols

2P2T ON-OFF-ON TOGGLE SWITCH	7.66
3P2T ON-OFF-ON TOGGLE SWITCH	7.66
4" AMBER LENS FOR STD LAMP	7.66

A

ACTUATOR,THROTTLE/EMULSION	7.13
ADPTR,RUBBER 45,3.00 ID	7.16
ADPTR,RUBBER 90,3.00 ID	7.16
AGGREATE HOPPER GROUP	7.30, 7.31, 7.32
AGGREGATE,TUBE W/M	7.34
AIR CLEANER,3.0 IN,3.0 OUT	7.16
AIR CLEANER,5"OUT/12" DIA	7.14
AIR INLET TUBE,W/M	7.14
AIR INTAKE SYSTEM	7.16, 7.17
AIR INTAKE SYSTEM,RA2000,FRANCE	7.8
AIR PRESS REGULATOR 5-125 PSIG	7.48
AIR RSVR,9.50X22.50,1488 CU IN	7.48
AMBER PILOT LAMP	7.66
ANCHOR,STEP GRATING	7.54
ANTIFREEZE,DEX-COOL	7.28
ARROW BOARD	7.66
Arrow Board	7.67
ARROW BOARD GROUP	7.66
Arrow Board Group	7.67
ASSY,BOOM CONTROL	7.38

B

BASE,BLOWER RAI-68	7.14
BASKET,MANHOLE SCREEN	7.62
BATTERY BOOT,POS(RED)	7.8
BATTERY,12V,950 CRK AMPS	7.10
BEARING REPLACEMENT SET 1.375X	7.44
BEARING,CONE AP04503-001,1.75I	7.44
BEARING,CONE,1.25ID	7.44
BEARING,CUP,INNER	7.44
BLOWER GROUP	7.14, 7.15
BLOWER GROUP,RA2000	7.8
BLOWER,POS DISPL,.395 CFR	7.14
BOOM CONTORL GROUP	7.45
BOOM CONTROL GROUP	7.44
BOOM CONTROL,BOX ASSY	7.42
BOOM SUB ASSEMBLY GROUP	7.42, 7.43
BOOM SUB ASSY	7.38
BOOM,END SECTION	7.44
BOOM,FIRST SECTION	7.44
BOOM,SECTION,1.75 HUB	7.44
BOTTOM,MANHOLE SCREEN	7.62
BRACE,ENGINE PANEL	7.12

BRACKET,EXTENSION	7.29
BRACKET,GAS SPRING	7.50
BRACKET,LICENSE PLATE	7.54
BRACKET,MERCURY SWITCH	7.50
BRACKET,RELAY MOUNT	7.20
BRACKET,SOLENOID,CUMMINS 4B3.9	7.8
BRACKET,SUPPORT	7.50
BRACKET,THROTTLE CABLE	7.13
BRACKET,WAND	7.60
BREATHER,04-MP	7.48
BRK'T,FRONT RUBBER	7.30
BRKT,RADIATOR MOUNT	7.12
BRK'T,SIDE RUBBER	7.30

C

CABLE,BATTERY,2 LUG,0GAX13	7.8
CABLE,BATTERY,NEG,14XOGA	7.8
CABLE,BATTERY,POS,16X0GA	7.8
CABLE,WIRE ROPE,.125-7X19G	7.38
CAP W/M, 2 NPT	7.38
CAP,WEATHER SEAL	7.26
CHAIN,SASH,#35,STEEL	7.42
CLAMP,DOUBLE TUBE,.75 ID	7.46
CLAMP,HOSE,.44-.78,WORM,#06	7.46, 7.48
CLAMP,HOSE,.50-.91,WORM,#08	7.28, 7.38, 7.40, 7.60
CLAMP,HOSE,1.31-2.25,WORM #28	7.12
CLAMP,HOSE,2.06-3.00,WORM,#40	7.12
CLAMP,HOSE,2.56-3.50,WORM,#48	7.16
CLAMP,HOSE,5.62-6.50,WORM,#96	7.34
CLAMP,LOOP,50 OD PLSTC COVER	7.30
CLAMP,LOOP,2.00 OD,PLSTC COVER	7.46
CLAMP,MUFFLER,2.5	7.18
CLAMP,MUFFLER,4.00	7.30, 7.38
CLAMP,T-BOLT,3.50 OD	7.16
CLAMP,T-BOLT,5.34 TO 5.66 ID	7.14
CLIP,WIRE ROPE,.063	7.38
COLLAR,SHAFT,SPLT,.50IDX1.12OD	7.28
COMPRESSED AIR GROUP	7.48, 7.49
CONDUIT,METAL FLEX,.50 ID	7.68
CONN HOUSING,CAP,12 CIRCUIT	7.20
CONN,BUTT,16-14 GA	7.50
CONNECTOR,SEALED,SHROUD,2-PIN	7.50
CONNECTOR,STR,FLEX CONDUIT,.50	7.26, 7.68
CONTACT,PIN,20-14 GA	7.20
CONTENTS PLATE, RA2000/RA300	7.29
CORD,ELEC,3WIRE,12 GA,300V	7.68
CORD,ELEC,3WIRE,12GA,300V	7.26
COUPLER,TORSIONAL,RA2000	7.14

Alphabetical Parts Index

COVER,POTENTIOMETER	7.28	DECAL,CAUTION,HEARING PROTECT	7.2
CRACK FILLING GROUP	7.60, 7.61, 7.66	DECAL,CAUTION,HOT SURFACE	7.2
CRG BOLT,.250-20X.75,GR5	7.42	DECAL,CAUTION,PROTECTIVE GEAR	7.4
CRG BOLT,.312-18X2.50,GR5	7.54	DECAL,CAUTION,RA2000	7.2
CRG BOLT,.375-16X1.25,GR5	7.38	DECAL,CAUTION,TIRE PRESSURE	7.4
CSHH,.250-20X.75,GR5	7.8, 7.13, 7.50	DECAL,CAUTION,TOWING CHAINS	7.4
CSHH,.250-20X1.00,GR5	7.28, 7.30	DECAL,CE YEAR	7.4
CSHH,.250-20X1.50,GR5	7.13, 7.38	DECAL,DANGER,FAN BLADES	7.2
CSHH,.250-20X1.75,GR5	7.42	DECAL,DANGER,FIRE/EXPLOSION	7.2
CSHH,.250-20X2.00,GR5	7.13	DECAL,DANGER,HIGH VOLTAGE	7.2
CSHH,.250-20X2.50,GR5	7.52	DECAL,DANGER,USE GFI CIRCUIT	7.4
CSHH,.250-20X5.50,GR5	7.60	DECAL,DIESEL FUEL	7.4
CSHH,.312-18X1.00,GR5		DECAL,DIESEL POWER,CUMMINS	7.4
7.12, 7.16, 7.18, 7.38, 7.44, 7.52, 7.54		DECAL,EMULSION	7.4
CSHH,.312-18X2.00,GR5	7.54	DECAL,FUSE LOCATION,RA200	7.20
CSHH,.375-16X.75,GR5	7.60	DECAL,FUSE PANEL, .63X3.31	7.20
CSHH,.375-16X.875,GR5	7.60	DECAL,GENERAL INSTRUCTION	7.4
CSHH,.375-16X1.00,GR5	7.8, 7.29, 7.38, 7.48	DECAL,HOT FLUID HAZARD,WARNING	7.4
CSHH,.375-16X1.25,GR5	7.30	DECAL,IGNITION SWITCH,RA200	7.22
CSHH,.375-16X1.50,GR5	7.10, 7.12, 7.60	DECAL,RELAY LOCATION	7.20
CSHH,.375-16X2.00,GR5	7.46	DECAL,RELAY LOCATION,THROTTLE	7.20
CSHH,.375-16X2.50,GR5	7.58	DECAL,ROSCO LOGO,MEDIUM,BLACK	7.4
CSHH,.375-16X5.00,GR5	7.44	DECAL,ROSCO LOGO,SMALL,BLACK	7.4
CSHH,.375-16X5.50,GR5	7.44	DECAL,SOLVENT TANK	7.2
CSHH,.375-16X9.50,GR5	7.8	DECAL,STRIPING,3 BAND BLACK	7.2
CSHH,.375-24X1.00,GR5	7.30	DECAL,TEMP CELSIUS (FOR 36682)	7.68
CSHH,.500-13X1.50,GR5	7.30	DECAL,THE PATCHER	7.2
CSHH,.500-13X2.00,GR5	7.44	DECAL,TRAILER MANUFACTUER	7.2
CSHH,.500-13X2.25,GR5	7.14	DECAL,WARNING,BATTERY INJURY	7.4
CSHH,.500-13X2.50,GR5	7.44	DECAL,WARNING,BOOM,RA200	7.4
CSHH,.500-13X7.00,GR5	7.44	DECAL,WARNING,ENGINE EXHAUST	7.4
CSHH,.625-11X4.00,GR8	7.54	DECAL,WARNING,GUARDS	7.2
CSHH,.625-11X4.50,GR8	7.54	DECAL,WARNING,KEEP CLEAN	7.2
CSHH,.750-10X2.50,GR5	7.28	DECAL,WARNING,PINCH HAZARD	7.50
CSHH,.750-10X4.00,GR5	7.8	DECAL,WARNING,UNDER PRESSURE	7.4
CSHH,M12X1.25X25,CL8.8	7.8	DOOR,SERVICE,EMUL TANK	7.28
CSHH,M12X1.75X35,CL8.8	7.10	DRAIN COCK,CABLE PULL,1/4 NPT	7.48
CSHH,M16X2.0X80,CL10.9	7.8	DUST CAP	7.44
CSHH,M8X1.25X75,CL8.8	7.48		
CSSH,.375-16X.75	7.14	E	
CYL,3.50X4.00,250PSI,11.17 OA	7.30	EDUCTOR NOZZLE W/M	7.30
CYLINDER,GAS SPRING,150#	7.50	EDUCTOR RECEIVER W/M	7.30
		EDUCTOR W/M	7.30
D		ELASTIC ELEMENT,SHORE A,65	7.14
DECAL GROUP	7.2, 7.3, 7.4, 7.5, 7.6, 7.7	ELBOW W/M,90 EXHAUST	7.18
DECAL PLATE,CE,BLANK,RA2000	7.4	ELBOW,EXHAUST,SR90,2.50 OD	7.18
DECAL PLATE,WRN,HOT MAT'L HAZ	7.2	ELEMENT,FILTER	7.18
DECAL, RA2000	7.2	ELEMENT,HEATER,2000W @ 240VAC	7.68
DECAL,BEACON	7.58	ELEMENT,HEATER,4500 W @ 240VAC	7.26

Alphabetical Parts Index

EMULSION TANK GROUP	7.28, 7.29	FITT,TEE 08MJ-08FJX-08MJ	7.46
EMULSION TANK INSULATE,RA2000	7.28	FITT,TEE 08MJ-08MJ-08FJX	7.46
ENGINE GROUP	7.8, 7.9, 7.10, 7.11	FITT,TEST 08FJ-02PD	7.46
ENGINE PANEL GROUP	7.50, 7.51, 7.52, 7.53	FLANGE, FLYWHEEL, 10.00 SAE	7.14
ENGINE, CUMMINS, 4B3.9, RA2000	7.8	FLASHER MODUAL WITH RELAY	7.66
EXHAUST GROUP, RA2000	7.8	FLOAT PIVOT ROD W/M, RA2000	7.29
EYE BOLT, 250-20X2.00X.56ID	7.38	FLOAT, 4.00 SPHERICAL SS304	7.28
EYE BOLT, LOCKING, MANHOLE COVER	7.44	FLOW GATE, EDUCTOR	7.30
F		FOAM, SOUND BARRIER, RA2000	7.50
FAN GUARD W/M	7.12	FRAME GROUP	7.36, 7.37
FENDER, BOLT ON, LH, FRANCE	7.36	FRAME W/M, RA2000	7.36
FENDER, BOLT-ON, RH	7.36	FUEL & FLUSH GROUP	7.46, 7.47
FILLER, HYD FLUID, 10 PSI	7.46	FUSE BLOCK, BLADE-TYPE, 6 POS	7.20
FILTER KIT (No Illustration)	7.18	FUSE, BLADE, 10AMP, ATC-10	7.20
FILTER, FUEL	7.18	FUSE, BLADE, 15AMP, ATC-15	7.20
FILTER, FUEL, DIESEL, INLINE	7.18	FUSE, BLADE, 5AMP, ATC-5	7.20
FILTER, FUEL, PRIMARY	7.18	G	
FILTER, OIL CUMMINS 4A & 4B	7.18	GAUGE, AMMETER, 60-0-60	7.20
FILTER, PRIMARY ELEMENT, XLP	7.16, 7.18	GAUGE, LIQUID LEVEL 12 O'CLOCK	7.46
FILTER, SAFETY ELEMENT	7.16, 7.18	GAUGE, PRESS, 0-160 PSI, 2.5 OD	7.28, 7.48
FINAL GROUP	7.54, 7.55, 7.56, 7.57	GAUGE, PRESS, OIL	7.20
FITT, 45 08MJ-08FJX	7.46	GAUGE, TEMP, WATER	7.20
FITT, 45 08MJ-08MP	7.48	GRATING, STEP, RA200	7.54
FITT, 90 04MP-04FP	7.46	GREASE, WHEEL BEARING	7.44
FITT, 90 04MP-06HB, CRIMPED	7.48	GRIP, HANDLE .125X2.75, FLAT	7.54
FITT, 90 06MP-06HB, CRIMPED	7.46, 7.48	GRIP, VINYL, .88ID, 4.75LG, BLACK	7.54
FITT, 90 08MJ-08FJX	7.48	GROMMET, INSULATION, 1.00ID	7.29
FITT, 90 08MJ-08MB	7.46	GUARD, RECEIVING HOPPER	7.30
FITT, 90 08MP-08FP	7.10	H	
FITT, 90 08MP-08HB, CRIMPED	7.8, 7.29, 7.40	HANDLE ASSY, HANDSPRAY GUN	7.60
FITT, LUBE, STR, 02MP, SHORT	7.44	HANDLE EXTENTION	7.28
FITT, METAL BALL SOCKET, 13MM	7.50	HANDLE, 6.00	7.50
FITT, STR 04MJ-02MP	7.48	HANDLE, GRAB, W/M, RA200	7.54
FITT, STR 04MJ-04MP	7.48	HANDLE, HAND SPRAY	7.60
FITT, STR 04MP-03HB, CRIMPED	7.46	HANDSPRAY GUN ASSEMBLY	7.60
FITT, STR 06FJX-06HB, PUSH-ON	7.46	HANDSPRAY GUN ASSY ASP	7.60
FITT, STR 06MJ-08MP	7.48	HANDSPRAY PIPE, ALUM	7.60
FITT, STR 06MP-06FJX	7.48	HARNES, BOOM, RA2000	7.24
FITT, STR 08FJ-08FP	7.46	HARNES, CONTROL HANDLE	7.24
FITT, STR 08FJX-08HB, PUSH-ON	7.46	HARNES, ENG, RA2000, FRANCE, ROT	7.10
FITT, STR 08MJ-06MB	7.46	HARNES, WIRE, JUMPER, ALTERNATOR	7.10
FITT, STR 08MJ-12MP	7.48	HARNES, WIRING, ALTERNATOR	7.10
FITT, STR 08MP-06HB, CRIMPED	7.28, 7.60	HEATER GROUP, 120V ELECTRIC	7.26
FITT, STR 08MP-08FJ	7.46	HINGE, CONTROL BOX	7.28
FITT, STR 08MP-08FPX	7.60	HINGE, ENGINE PANEL ASSEMBLY	7.50
FITT, STR 08MP-08HB, CRIMPED ...	7.8, 7.28, 7.60	HITCH, ADJUSTABLE TONGUE, W/M	7.54
FITT, STR 08MP-08HB, PUSH-ON	7.28, 7.38, 7.40, 7.46, 7.60	HOLD DOWN, BATTERY	7.8
FITT, TEE 02MP-02FP-02FP, STL	7.10		

Alphabetical Parts Index

HOLDER,WASTE SOLVENT PAIL	7.38	LUNETTE EYE,3" (7.62cm),ADJUSTABLE	7.58
HOOD,AIR INLET,3.00 PLASTIC	7.16		
HOOK,HOSE,4.00	7.30	M	
HOOK,MANHOLE SCREEN	7.62	MACH SCR,PH,#10-24X.75	7.20, 7.50, 7.58
HOOK,S,.120WIRE,.50EYE,1.74LG	7.42	MACH SCR,PH,#10-24X1.00	7.22
HOSE, AGGREGATE 5.00X36.00	7.34	MACH SCR,PH,#10-32X.25,PHIL	7.26, 7.68
HOSE REEL-RETRACT,W/RATCHET ST	7.60	MACH SCR,PH,#10-32X.75	7.46, 7.54
HOSE STOP	7.60	MACH SCR,PH,#6-32 X 1.50	7.48
HOSE,03,PUSH-ON,.250	7.46	MACH SCR,PH,#8-32X.75	7.29
HOSE,04 04FJX-04FJ90,180 OS	7.48	MACH SCR,PH,.250-20X.75	7.22
HOSE,04,PUSH-ON,LOW PRESS	7.38	MAST,BOOM,1.75 SPINDLE	7.44
HOSE,06,PUSH-ON,250,BLUE ...	7.28, 7.46, 7.48	MOUNTING BAND,6.50 ID	7.16, 7.18
HOSE,08 08FJX-08FJX,TEFLON	7.48	MOUNTING BRACKET,STROBE LIGHT	7.58
HOSE,08,PUSH-ON,250	7.28, 7.40, 7.46, 7.60	MOUNT,INTAKE SUPPORT	7.16
HOSE,08X300,08M(2),1750	7.60	MOUNT,RUBBER,TUBE FORM,400 LB	7.8
HOSE,HOT AIR,3.5ID,300F,150PSI	7.30	MUFFLER,EXH 6.50 OD,2.5 IN/OUT	7.18
HOSE,POLY,3.50ID,CONVOL. COVER	7.38		
HOSE,RAD,1.75 ID,90 DEG	7.12	N	
HUB,1.375 BORE,.250 KEYWAY	7.14	NOZZLE ASSY,RA2000	7.38
HYDRAULIC BRAKE ACTUATOR	7.64	NOZZLE GROUP	7.40, 7.41
		NOZZLE W/M,RA2000	7.40
I		NOZZLE,EMULSION SPRAY,.063	7.40
INDICATOR,AIR CLEANER	7.4, 7.14, 7.16	NOZZLE,EMULSION SPRAY,.078	7.40
INSTRUMENT HOUSING W/M	7.20	NUT,6BF SPINDLE	7.44
INSTRUMENT PANEL GROUP		NUT,FLEXLOC,#10-24,FULL,LT	7.50, 7.58
7.20, 7.21, 7.22, 7.23		NUT,FLEXLOC,.250-20,FULL,LT	
INSTRUMENT PANEL W/M	7.20	7.8, 7.13, 7.30, 7.38, 7.42, 7.46, 7.52	
INSTRUMENT WIRING GROUP	7.24, 7.25	NUT,FLEXLOC,.312-18,FULL,LT	
INSULATION,TUBE,1.12IDX.38WALL	7.28	7.8, 7.16, 7.18, 7.46, 7.52, 7.54	
INSULATION,TUBE,1.62IDX.38WALL ...	7.38, 7.40	NUT,FLEXLOC,.375-16,FULL,LT	7.10, 7.12
INSULATION,TUBE,3.62IDX.5WX72"	7.28	NUT,FLEXLOC,.500-13,FULL,LT ..	7.14, 7.30, 7.44
		NUT,FLEXLOC,.625-11,FULL,LT	7.54
K		NUT,FLEXLOC,.750-10,FULL,LT	7.8, 7.28
KIT,HORN	7.24	NUT,FLOAT ROD PIVOT	7.28
		NUT,HEX,#10-24	7.22
L		NUT,HEX,#10-32	7.54
LATCH,DRAW	7.50	NUT,HEX,#6-32	7.48
LEVER,08 BALL VALVE	7.38	NUT,HEX,#8-32	7.29
LEVER,THROTTLE	7.13	NUT,HEX,.250-20	7.13, 7.28, 7.38, 7.50
LIGHT,240V,.33W,RED	7.68	NUT,HEX,.250-20,GR2	7.60
LIGHT,GREEN INDICATOR	7.26	NUT,HEX,.312-18	7.36, 7.38, 7.44
LIGHT,STROBE, AMBER,W/FLASHER	7.58	NUT,HEX,.375-16	7.38, 7.44, 7.48, 7.58, 7.60
LINK,QUICK,.188 CHAIN	7.38	NUT,HEX,.500-13	7.44
LOCK,WITH OFFSET CAM	7.28	NUT,HEX,.625-11	7.54
LOOM,SPLIT,CONVOLUTED,.250	7.50	NUT,HEX,CASTLE,.875-14	7.44
LOUVRE, BOTTOM	7.50	NUT,HEX,JAM,1.000-8	7.30
LOUVRE, TOP	7.50	NUT,HEX,M10X1.50	7.10
LUBE,BLOWER,AEON PD,QUART	7.14	NUT,HEX,M5X.80	7.10
		NUT,INSERT,.375-16,.027-.150,S	7.29

Alphabetical Parts Index

NUT,WING,.250-20	7.42	PIPE,PLUG,12MP,SKT HD,MI	7.48
NUT,WING,.50-13	7.44	PIPE,PLUG,16MP,SQ HD,MI	7.28
O		PIPE,RED,08FP-04FP-MI	7.29
O-RING,.487IDX.103CS,VITON	7.28	PIPE,TEE,08FP,MI	7.28, 7.60
OUTER RACE	7.44	PIPE,TEE,08MP-08FP-08FP,STL	7.46, 7.48
P		PIPE,TOE,3.00X4.00	7.30
PAINT,CAT 1 YELLOW,ACRYLIC	7.54	PLATE,COVER	7.29
PAINT,ROSCO YELLOW,TOUCH-UP	7.54	PLATE,HOSE REEL MOUNT	7.60
PANEL MOUNT FUSE HOLDER	7.66	PLATE,REAR,LOWER	7.50
PANEL,FRONT	7.50	PLATE,REAR,UPPER	7.50
PANEL,HOOD,REAR	7.50	PLATE,SERIAL NUMBER ROSCO	7.2
PANEL,INSTRUMENT GRP,RA2000	7.24	PLATE,U-BOLT,.56X5.50 CENTERS	7.44
PANEL,LEFT	7.50	PLATE,WASTE BUCKET	7.38
PANEL,LOUVRE MOUNT,LH	7.50	PLUG,ELEC,FEMALE,20A,125V	7.26
PANEL,LOUVRE MOUNT,RH	7.50	PLUG,ELEC,FEMALE,30A,250V	7.68
PANEL,RIGHT	7.50	POINTER ASSY	7.28
PAPER GASKET FOR STD LAMP	7.66	PUMP,MOTOR,3GPM,12VDC,100PSI	7.46
PIN,QUICK RELEASE,.25X1.3 GRIP	7.42	R	
PIPE,45,08FP,GAL	7.60	RADIATOR AND THROTTLE GROUP	7.13
PIPE,45,08MP-08FP,MI	7.40	RADIATOR AND THROTTLE GROUPS	7.12
PIPE,45,3.00FP,MI	7.30	RADIATOR GROUP,RA2000	7.8
PIPE,90,02MP-02FP,MI	7.14, 7.48	RADIATOR,CUMMINS 4B3.9	7.12
PIPE,90,08FP,MI	7.40	RCPT,ELEC,MALE,20A,125V,FLG IN	7.26
PIPE,90,08MP-08FP,MI	7.40	RCPT,ELEC,MALE,30A,250V,FLG IN	7.68
PIPE,90,2.00FP,MI	7.28	REAR FRAME W/M	7.44
PIPE,90,3.00FP,MI	7.30	REFLECTIVE TAPE,1.50,RED/WHITE	7.4
PIPE,BUSH 5.00MP-3.00FP,MI	7.30	RELAY,SPDT,40AMP,12VDC	7.20
PIPE,BUSH,08MP-04FP,STL	7.28, 7.46	RETAINING RING FOR STD LAMP	7.66
PIPE,BUSH,08MP-06FP,MI	7.48	RIVET,BLIND,AL,.188,.020-.125	7.2
PIPE,BUSH,12MP-08FP,STL	7.40	RIVET,BLIND,ALUMINUM,.125,.126-.187	7.4
PIPE,BUSH,2.00MP-08FP,MI	7.28	RIVET,BLIND,STL,.188,.020-.125	7.62
PIPE,BUSH,2.00MP-16FP,MI	7.28	ROD W/M,PROP	7.50
PIPE,CPLG,04FP	7.48	ROD,BOOM CONTROL	7.42
PIPE,CROSS,04FP,MI	7.48	ROLLER,VCUT,ASSY,S/B GUIDE	7.44
PIPE,CROSS,08FP,MI	7.28	RUBBER,HOPPER FRONT	7.30
PIPE,EXHAUST	7.18	RUBBER,HOPPER REAR	7.30
PIPE,NIPPLE,02XCLOSE	7.14	RUBBER,HOPPER SIDE	7.30
PIPE,NIPPLE,04XCLOSE(7/8)	7.48	S	
PIPE,NIPPLE,06XCLOSE	7.48	SAFETY CLIP,13MM	7.50
PIPE,NIPPLE,08X2.50	7.40	SCREEN,100 MESH,Y-STRAINER	7.18
PIPE,NIPPLE,08XCLOSE	7.28, 7.40, 7.60	SCREW,WING .375-16 X 1.00	7.30
PIPE,NIPPLE,16XCLOSE	7.28	SCR,SLFDRL,HH,#10X1.00,#3PT	
PIPE,NIPPLE,2.00X3.50	7.28, 7.38	7.28, 7.52, 7.54, 7.60	
PIPE,NIPPLE,3.00X9.00	7.30	SCR,SLFDRL,HH,.250-14X1.00	7.28
PIPE,PLUG,04MP,SQ HD,MI	7.29, 7.46	SCR,SLFTPG,PH,#10X.500,AB	7.26, 7.68
PIPE,PLUG,08MP,SQ HD,MI	7.40, 7.46	SEAL,CABLE,18-16 GA	7.50

Alphabetical Parts Index

SEAL, GREASE, 2.25ID, 3.75OD, SLG	7.44	TUBE, RND, .375X18 GA, DOM X .625	7.13
SEAL, TRIM, PUSH-ON, RUB, .063GRIP	7.50	TUBE, RND, 3.00X4.00	7.16
SENDER, PRESS, OIL, 02 MP	7.8	U	
SENDER, TEMP GAUGE, 08 MP	7.8	U-BOLT, 250-20, 1.12IW, 2.00IL	7.38
SET S, .250-20X.50	7.28	V	
SET S, HSKT, KCUP, 250-20X.25	7.28	VLV, AIR, SAFETY, 125PSI, 04 NPT	7.28, 7.48
SET S, SQ, CUP, 250-20X.50	7.50	VLV, AIR, SOL, 2POS, 5PORT, .02	7.48
SILENCER, 3.0 NPT	7.30	VLV, BALL, 06 NPT	7.48
SLEEVE, ABRASION, 10.0X216.0	7.38	VLV, BALL, 08 NPT, T HANDLE	7.28, 7.40
SLEEVE, ABRASION, NYLON, .71ID	7.38	VLV, BALL, 08-BRASS	7.38, 7.60
SLEEVE, ABRASION, NYLON, 3.20ID	7.40	VLV, BALL, 1.00, BRONZE	7.28
SLEEVE, ABRASIVE, 9.50 X 27.00	7.38	VLV, BALL, 3-WAY, 08 NPT	7.28
SLIDE GATE, EDUCTOR	7.30	VLV, CHECK	7.40
SOLENOID, INTERMIT DUTY, 12VDC	7.10	VLV, CHECK 06HB, POLY (1PSI)	7.46
SPACER, EDUCTOR, .25 THICK	7.30	VLV, CHECK, 08FP, .50 PSI CRACK	7.28
SPACER, EDUCTOR, .50 THICK	7.30	VLV, DRAIN .25	7.46
STANDARD LAMP FOR TG-A1	7.66	VLV, DRAIN COCK, .25	7.28
STRAINER, Y, 08FP, 100 MESH	7.46	VLV, HANDSPRAY, .50, W/HANDLE	7.60
STRIP, ABRASIVE, 4"X60'ROLL, BLK	7.4	W	
STRIP, ADH SPONGE, .75X.062	7.50	W/M, BOOM HOLDER, FENDER	7.38
STRIPPING, .062	7.54	W/M, CONTROL HANDLE	7.42
STUD, BALL, 5/16-18	7.50	W/M, FLOAT ROD	7.29
SWITCH SUPPORT W/M	7.50	W/M, FLOOR PLATE	7.50
SWITCH, IGNITION, 3 POS, 30 AMP	7.20	W/M, FRONT HOOD	7.50
SWITCH, MERCURY	7.50	W/M, REAR PANEL	7.50
SWITCH, PRESSURE, 02 MP, NO & NC	7.8	WASHER, 3.25ODx.80IDx.188T	7.8
SWITCH, PUSH-PULL, ON/OFF, 12V	7.58	WASHER, LOCK, INT TOOTH, .250	7.22
T		WASHER, SAE PLAIN, .375	7.30, 7.48
TACH/HOUR METER	7.20	WASHER, SAE PLAIN, .625	7.8, 7.54
TAIL GATE GROUP	7.34, 7.35	WASHER, SAE PLAIN, .875	7.44
TANK W/M, FUEL/FLUSH, RA2000	7.46	WASHER, SAE, HARDENED, .375	7.46
TERM, CRIMP, 12-10 GA	7.22	WASHER, SAE, HARDENED, .500	7.14
TERM, CRIMP, 16-14 GA	7.20	WASHER, SPLIT LOCK, #10	7.22, 7.26, 7.46, 7.54, 7.68
TERM, PUSH-ON, .25, FEM, 16-14 GA	7.20	WASHER, SPLIT LOCK, #8	7.29
TERM, RING, 12-10 GA, #10 STUD	7.20	WASHER, SPLIT LOCK, .250	7.50
TERM, RING, 16-14 GA, #10 STUD	7.22, 7.26, 7.68	WASHER, SPLIT LOCK, .3127.12, 7.36, 7.38, 7.44	7.14, 7.30, 7.38, 7.44, 7.58, 7.60
TERM, RING, 16-14 GA, #6 STUD	7.20	WASHER, SPLIT LOCK, .375	7.14, 7.30, 7.38, 7.44, 7.58, 7.60
TERM, RING, 6 GA, .375 STUD	7.46	WASHER, SPLIT LOCK, .500	7.44
TERM, SEALED CONN, 16-14 GA, MALE	7.50	WASHER, SPLIT LOCK, .625	7.8, 7.54
THERM, DIAL, 5.0 FACE, 500 F	7.28	WASHER, SPLIT LOCK, M10	7.8
THERMOSTAT, ELEC, 110-170 DEG F ...	7.26, 7.68	WASHER, SPLIT LOCK, M12	7.8
THIMBLE, CABLE, .250	7.38	WASHER, SPLIT LOCK, M5	7.10
THROTTLE GROUP, RA2000, ROTARY	7.8	WASHER, SPLIT LOCK, M8	7.48
TIE DOWN, RUBBER, 15, W/HOOKS	7.34, 7.38		
TIE WRAP, .188X7.5	7.20		
TUBE, EXHAUST, RA2000	7.18		
TUBE, FLEX EXHAUST, 2.50 ID	7.18		

Alphabetical Parts Index

WASHER,TYPE A PLAIN,#10	7.22, 7.50
WASHER,TYPE A PLAIN,#6	7.48
WASHER,TYPE A PLAIN,#8	7.29
WASHER,TYPE A PLAIN,.250	
7.10, 7.13, 7.30, 7.38, 7.42, 7.46, 7.50	
WASHER,TYPE A PLAIN,.312	
7.8, 7.12, 7.36, 7.38, 7.44, 7.48, 7.50, 7.54	
WASHER,TYPE A PLAIN,.375	
7.8, 7.12, 7.29, 7.30, 7.38, 7.46, 7.60	
WASHER,TYPE A PLAIN,.500	7.10, 7.30
WASHER,TYPE A PLAIN,.625	7.54
WASHER,TYPE A PLAIN,.750	7.8, 7.28
WASHER,TYPE A PLAIN,1.000	7.44
WASTE BUCKET, W/M	7.38
WIRE,10 GA,RED	7.22
WIRE,10 GA,WHITE	7.20
WIRE,16 GA,BLACK	7.20
WIRE,16 GA,BLACK/YELLOW STRIPE	7.20, 7.50
WIRE,16 GA,BLUE	7.20
WIRE,16 GA,BLUE/RED STRIPE	7.20
WIRE,16 GA,BROWN	7.20
WIRE,16 GA,BROWN/YELLOW STRIPE	7.20
WIRE,16 GA,DK GREEN/YEL STRIPE	7.20
WIRE,16 GA,GRAY/BLACK STRIPE	7.20
WIRE,16 GA,GREEN	7.20
WIRE,16 GA,GREEN/WHITE STRIPE	7.20
WIRE,16 GA,ORANGE	7.20
WIRE,16 GA,ORANGE/YEL STRIPE	7.20
WIRE,16 GA,PINK	7.20
WIRE,16 GA,PURPLE	7.20
WIRE,16 GA,PURPLE/WHITE STRIPE	7.20
WIRE,16 GA,RED	7.20
WIRE,16 GA,RED/BLACK STRIPE	7.20
WIRE,16 GA,WHITE/BLACK STRIPE	7.20
WIRE,16 GA,YELLOW	7.20, 7.50
WIRE,16 GA,YELLOW/RED STRIPE	7.20
WIRE,6 GA,BLK	7.46

WIRE COLOR	DESIGNATION
BLUE	BLU
BROWN	BRN
GREEN	GRN
ORANGE	ORN
PINK	PINK
PURPLE	PRP
RED	RED
WHITE	WHT
YELLOW	YEL

NO 1 CONNECTOR			
PIN NO	WIRE COLOR	WIRE GA	ITEM #
1	WHITE	10	--
2	RED	10	--
3	YELLOW	16	--
4	RED	16	--
5	BROWN	16	--
6	ORANGE	16	--
7	BLUE	16	--
8	PURPLE	16	--
9	PINK	16	--
10	GREEN	16	--
11	-----	--	--
12	-----	--	--

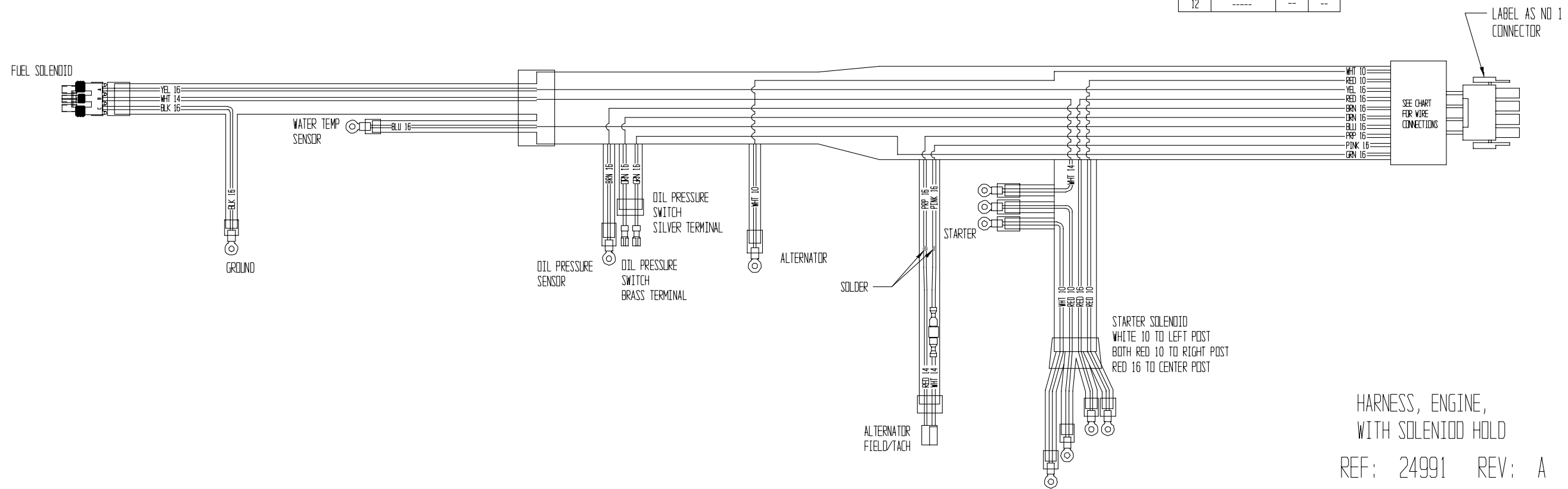

HARNESS, ENGINE,
WITH SOLENOID HOLD
REF: 24991 REV: A

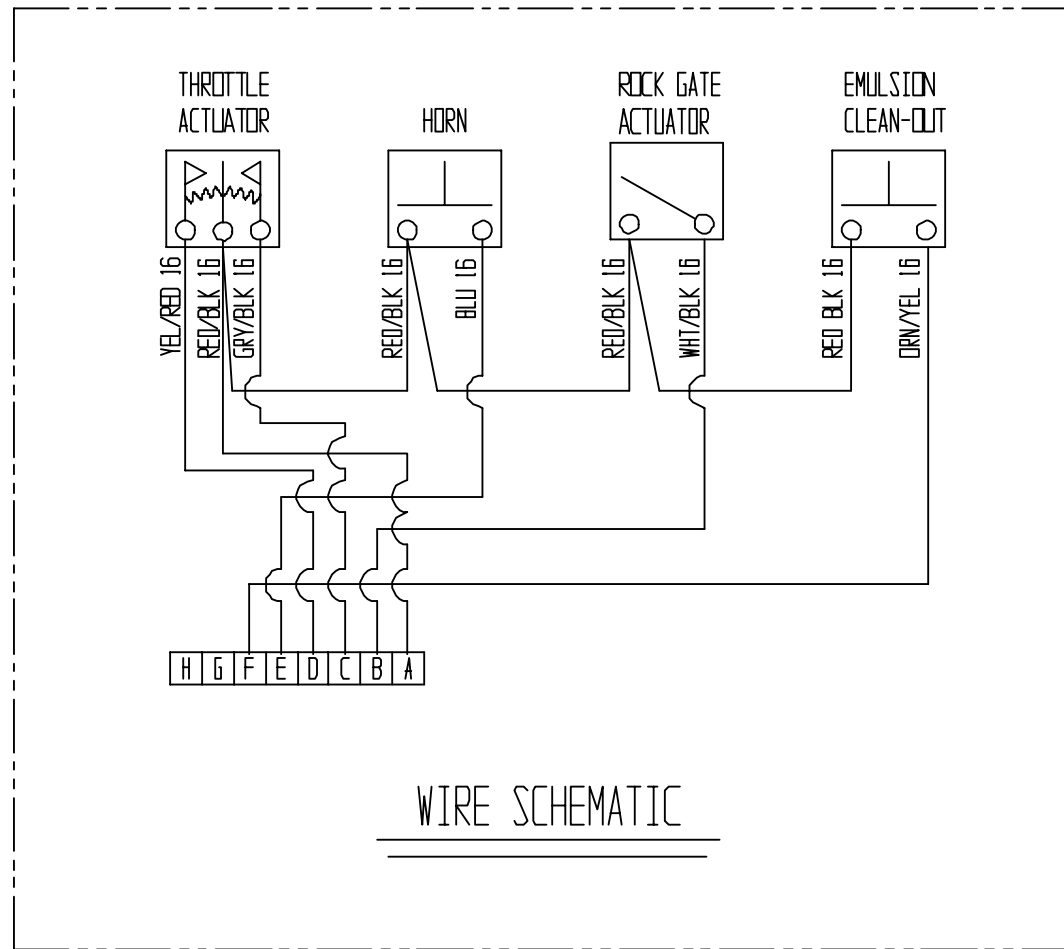

WIRE SCHEMATIC

SOCKET	WIRE COLOR	WIRE ITEM NO
A	RED/BLK	5
B	WHT/BLK	7
C	GRY/BLK	8
D	YEL/RED	6
E	BLU	4
F	DRN/YEL	9
G	PLUG	3
H	PLUG	3

CONTROL HANDLE BOX

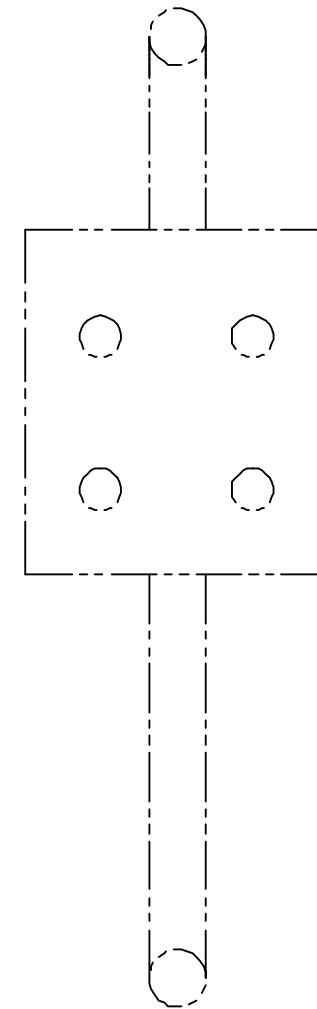

HARNESS.
CONTROL HANDLE
REF: 25546 REV: B

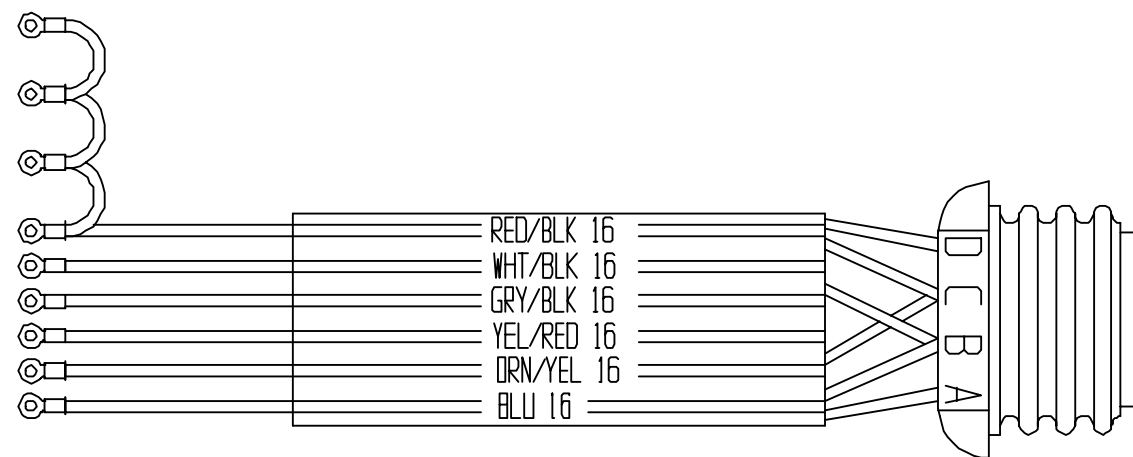

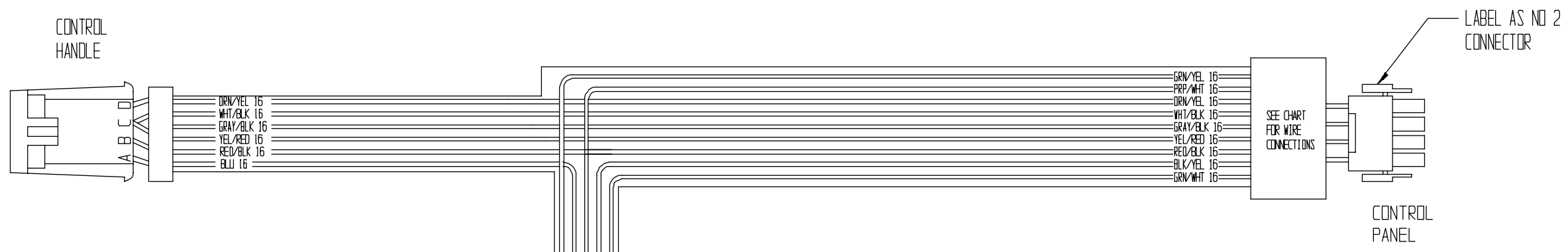

SOCKET	WIRE COLOR	WIRE ITEM NO
A	RED/BLK	5
B	WHT/BLK	10
C	GRY/BLK	12
D	YEL/RED	7
E	BLU	4
F	ORN/YEL	13
G	PLUG	31
H	PLUG	31

NO 2 CONNECTOR			
PIN NO	WIRE COLOR	WIRE GA	ITEM #
1	YEL/RED	16	6
2	GRN/WHT	16	3
3	BLK/YEL	16	5
4	GRAY/BLK	16	11
5	RED/BLK	16	4
6	WHT/BLK	16	9
7	GRN/YEL	16	10
8	ORN/YEL	16	12
9	PRP/WHT	16	8
10	----	--	--
11	----	--	--
12	----	--	--

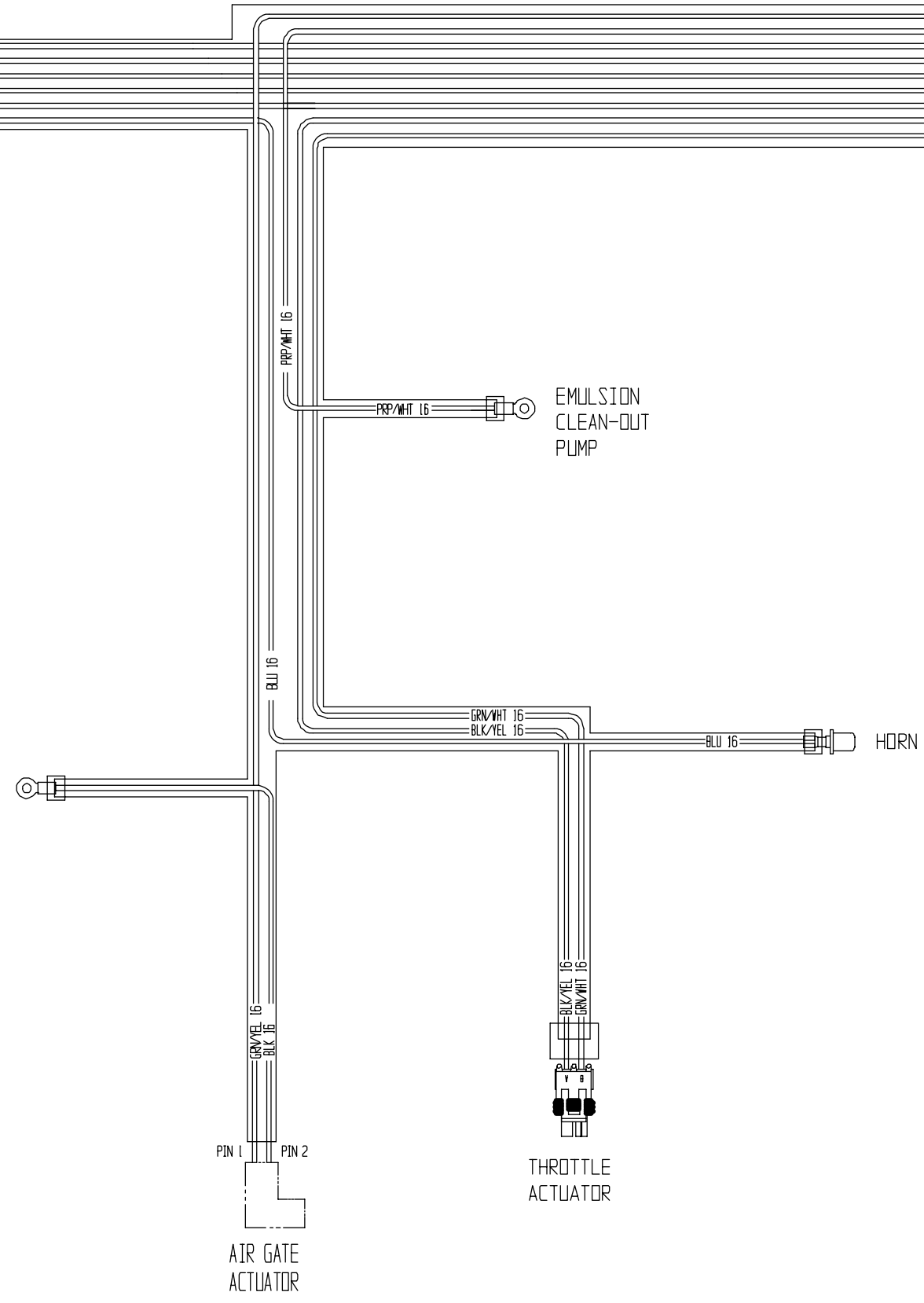

HARNESS, BOOM, RA2000
 REF: 25545 REV: B

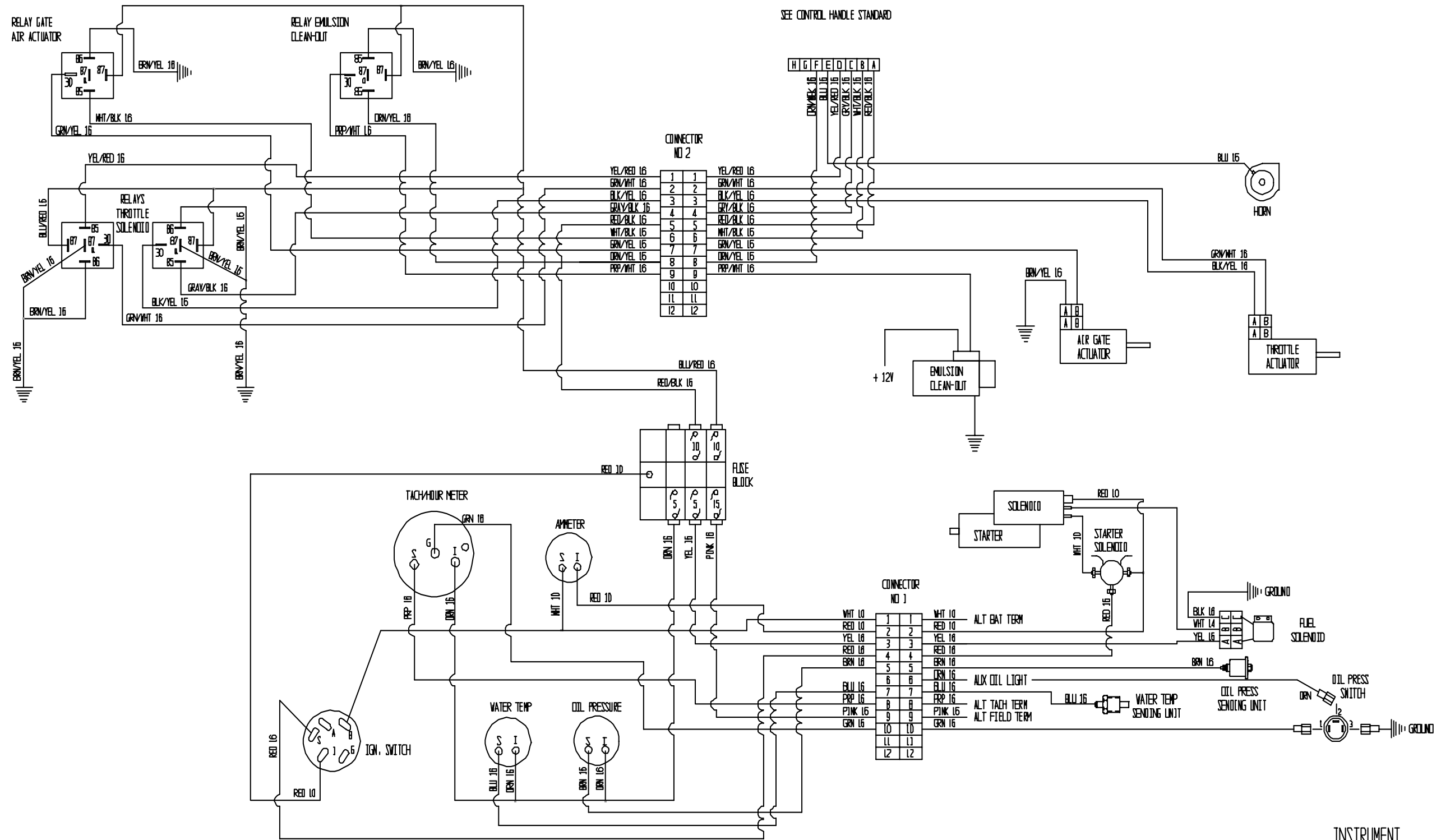

INSTRUMENT,
WIRING GRP
REF: 25527 REV: A