

# **RDSCO**

*A LeeBoy Company*

## **VIBRASTAT III & STAPAC III Asphalt Rollers**

**OPERATION - MAINTENANCE - PARTS MANUAL**

**MANUAL PART NO. 37443-01**

EFFECTIVE SERIAL NO.34243 and higher

REVISED 7/31/97

**NOTE:** It is the responsibility of the customer or user's management to train, educate and supervise the employee in the proper operation and maintenance of this equipment.

688 North Highway 16  
Denver, North Carolina  
[www.LeeBoy.com](http://www.LeeBoy.com)  
Phone: 704-966-3300

# TABLE OF CONTENTS

This MANUAL is arranged in SECTIONS, with the pages numbered consecutively in each SECTION. Any photographs or artists renderings are also numbered consecutively in each SECTION. Included on the bottom of each page is the Model, Section Number and Page Number.

<b>SECTION I - PREFACE</b>	<b>PAGE</b>
1. Warranty .....	1.2 - 1.3
2. Specifications .....	1.4 - 1.5
3. Introduction .....	1.6
4. Serial Number Plate Location .....	1.7
5. General Description .....	1.8 - 1.9
6. Safety Precautions .....	1.10 - 1.15
7. Sign-Off Form .....	1.16
8. Safety Decals .....	1.17 - 1.19
 <b>SECTION II - OPERATION</b>	
1. General .....	2.2
2. Pre-Operating Check List .....	2.2
3. Start-up and Operation .....	2.2 - 2.3
4. Spraybar Water System .....	2.3 - 2.4
5. Drum Ballast .....	2.4
6. Static Steel Drum Rollers .....	2.4
7. Vibrastat III Operating Hints .....	2.4 - 2.6
8. Rolling Pattern .....	2.6
9. Shutdown Operation .....	2.6
10. Transport Wheels (Option) .....	2.6 - 2.7
11. Combating Poor Visibility .....	2.8
 <b>SECTION III - MAINTENANCE</b>	
1. General .....	3.3
2. Service Interval Chart .....	3.3
3. Fuel .....	3.4
4. Engine Oil .....	3.4
5. Engine Oil Change .....	3.4 - 3.5
6. Engine Air Cleaner .....	3.5 - 3.6
7. Engine Fuel Filter (Gasoline) .....	3.6
8. Engine Spark Plug (Gasoline) .....	3.6 - 3.7
9. Engine Spark Arrester (Gasoline) .....	3.7
10. Engine Radiator (Diesel) .....	3.7 - 3.8
11. Engine Fan Belt (Diesel) .....	3.8
12. Engine Battery .....	3.8 - 3.9
13. Hydraulic Fluid .....	3.9
14. Transmission Control Lever .....	3.9 - 3.10
15. Drive Chain Adjustment .....	3.11
16. Re-Centering Sprocket .....	3.11
17. Park/Emergency Brake Maintenance .....	3.12
18. Chassis Maintenance .....	3.12 - 3.13
19. Storage .....	3.13 - 3.14
20. Hydraulic Fluids .....	3.15

(CONTINUED NEXT PAGE)

# TABLE OF CONTENTS

## SECTION IV - MAINTENANCE (CONT.)

21. Hydraulic Fitting Torque Chart .....	3.16
22. Bolt Torque Chart .....	3.17
23. Trouble Shooting .....	3.18 - 3.21

## SECTION IV - VIBRASTAT III PARTS BOOK

1. Vibrastat III Parts Book Table of Contents .....	4.1
2. Main Assembly .....	4.2 - 4.9
3. Front Drum/Yoke Assembly .....	4.10 - 4.11
4. Front Steel Scraper & Coco Mat .....	4.12 - 4.13
5. Rear Drum Assembly .....	4.14 - 4.15
6. Rear Steel Scraper & Coco Mat .....	4.16 - 4.17
7. Engine Assembly, 20 HP .....	4.18 - 4.19
8. Engine Sub Assembly - Hydraulics .....	4.20 - 4.23
9. Engine Wiring Harness .....	4.24 - 4.25
10. Transmission Control Lever .....	4.26 - 4.27
11. Steering Gear (Exploded View) .....	4.28 - 4.29
12. Final Assembly - Decals & Miscellaneous .....	4.30 - 4.33
13. Vibrastat Alphabetical Parts Index .....	4.35 - 4.37

## SECTION V - STAPAC III PARTS BOOK

1. Stapac III Parts Book Table of Contents .....	5.1
2. Main Assemble .....	5.2 - 5.9
3. Rear Steel Scraper & Coco Mat .....	5.10 - 5.11
4. Front Drum/Yoke Assembly .....	5.12 - 5.13
5. Front Steel Scraper & Coco Mat .....	5.14 - 5.15
6. Engine Assembly, 20 HP .....	5.16 - 5.17
7. Engine Sub Assembly - Hydraulics .....	5.18 - 5.19
8. Engine Wiring Harness .....	5.20 - 5.21
9. Transmission Control Lever .....	5.22 - 5.23
10. Steering Gear (Exploded View) .....	5.24 - 5.25
11. Final Assembly - Decals & Miscellaneous .....	5.26 - 5.29
12. Stapac Alphabetical Parts Index .....	5.31 - 5.34

## SECTION VI - VIBRASTAT III & STAPAC III OPTIONS

1. Options Parts Book Table of Contents .....	6.1
2. Transport Wheel Assembly without Brakes .....	6.2 - 6.5
3. Transport Wheel Assembly with Brakes (No Illustration) .....	6.6
4. Tow Bar - Hydraulic Group .....	6.7
5. Transmission By-Pass Valve Group .....	6.8 - 6.9
6. Vandal Groups .....	6.10 - 6.11
7. Light Group (No Illustration) .....	6.12
8. Vandalism Protection Group (No Illustration) .....	6.12
9. Backup Alarm Group (No Illustration) .....	6.12
10. Ammeter Group (No Illustration) .....	6.12
11. Adjustable Hitch Assembly (No Illustration) .....	6.12
12. Strobe Mount Group (No Illustration) .....	6.12
13. SMV Group (No Illustration) .....	6.12
14. Service Kit, Vibrastat III, Gasoline (No Illustration) .....	6.13
15. Service Kit, Stapac III, Gasoline (No Illustration) .....	6.13
16. Decal Kit, Vibrastat III (No Illustration) .....	6.13
17. Decal Kit, Stapac III (No Illustration) .....	6.14
18. Service Kit, Vibrastat III, Diesel (No Illustration) .....	6.14
19. Service Kit, Stapac III, Diesel (No Illustration) .....	6.14

(CONTINUED ON NEXT PAGE)

# TABLE OF CONTENTS

<b>SECTION VI - VIBRASTAT III &amp; STAPAC III OPTIONS (Cont.) .....</b>		
20.	Gauge Package Group, Diesel Engine .....	6.16 - 6.17
21.	Gauge Package Group, Gasoline Engine .....	6.18 - 6.19
22.	Hydraulic Temperature Light Group .....	6.20 - 6.21
23.	Low Oil Pressure Shutdown Group .....	6.22 - 6.23
24.	Water Pump Group .....	6.24 - 6.25
25.	Kubota Diesel Engine Option - Vibrastat III	
	Main Assembly .....	6.26 - 6.33
	Engine Assembly .....	6.34 - 6.41
	Final Assembly .....	6.42 - 6.45
26.	Wire Harness - Kubota Diesel Engine Option - Vibrastat and Stapac .....	6.46 - 6.47
27.	Kubota Diesel Engine Option - Stapac III	
	Main Assembly .....	6.48 - 6.55
	Engine Assembly .....	6.56 - 6.61
	Final Assembly .....	6.62 - 6.65
28.	Options Alphabetical Parts Index .....	6.66 - 6.71

# SECTION I

## PREFACE

1. WARRANTY .....	1.2 - 1.3
2. SPECIFICATIONS .....	1.4 - 1.5
3. INTRODUCTION.....	1.6 - 1.7
4. SERIAL NUMBER LOCATION .....	1.7
5. COMPACTION .....	1.8
6. SAFETY .....	1.9 - 1.19
SAFETY SYMBOLS AND SIGNAL WORDS .....	1.9
SAFETY PRECAUTIONS.....	1.10 - 1.15
SIGN-OFF FORM.....	1.16
SAFETY DECALS .....	1.17 - 1.19



# **DELUXE ROLLPAC III**

## **LIMITED WARRANTY POLICY & PROCEDURES**

### **A. WARRANTY**

1. If a defect in material or workmanship is found and the authorized Dealer is notified during the warranty period, ROSCO will repair or replace any part or component of the unit or part that fails to conform to the warranty during the warranty period.
2. The warranty will begin upon the completion of the warranty form by the initial customer and will expire after twelve (12) months have passed. The Warranty Card must be filled out within ten (10) days of delivery of the unit.
3. Engines and truck chassis are warranted by their manufacturers and may have warranty coverage that differs from that of ROSCO.
4. Replacement parts furnished by ROSCO are covered for the remainder of the warranty period applicable to the unit or component in which such parts are installed.
5. ROSCO has the right to repair any component or part before replacing it with a new part.
6. All new replacement parts purchased by a ROSCO dealer will carry a six (6) month warranty. Remanufactured parts purchased by a ROSCO dealer will carry a ninety (90) day warranty.

### **B. LIMITATIONS**

ROSCO has no obligation under this warranty for:

1. Any defects caused by misuse, misapplication, negligence, accident or failure to maintain or use in accordance with the most current operating instructions.
2. Unauthorized alterations.
3. Defects or failures caused by any replacement parts or attachments not manufactured by or approved by ROSCO.
4. Failure to conduct normal maintenance and operating service, including without limitation, providing lubricants, coolant, fuel, tune-ups, inspections or adjustments.
5. Unreasonable delay, as established by ROSCO, in making the applicable units or parts available upon notification of a service notice ordered by ROSCO.
6. The warranty responsibility on all engines and/or truck chassis rests with the respective manufacturer.
7. ROSCO may have support agreements with some engine and/or truck chassis manufacturers for warranty and parts support.

# **DELUXE ROLLPAC III**

## **LIMITED WARRANTY POLICY & PROCEDURES**

### **C. ITEMS NOT COVERED**

ROSCO is not responsible for the following:

1. Charges for travel time, mileage or overtime.
2. Charges related to transporting the product to and from the place at which warranty work is performed.
3. Freight charges related to transporting repair parts to the place at which warranty work is performed.
4. All used units or used parts of any kind.
5. Repairs made necessary by normal wear and tear or brought about by abuse or lack of maintenance of the equipment, except for premature failures.
6. Attachments not manufactured or installed by ROSCO.
7. Liability for incidental or consequential damages of any type, including, but not limited to lost profits or expenses of acquiring replacement equipment.
8. Miscellaneous charges.

### **D. OTHER WARRANTIES**

THE FOREGOING WARRANTY IS EXCLUSIVE AND IN LIEU OF ALL OTHER EXPRESSED, STATUTORY AND IMPLIED WARRANTIES APPLICABLE TO UNITS, ENGINES OR PARTS, WITHOUT LIMITATION, AND ALL IMPLIED WARRANTIES OF MERCHANTABILITY OR FITNESS FOR ANY PARTICULAR USE OR PURPOSE. IN NO EVENT, WHETHER AS A RESULT OF BREACH OF CONTRACT OR WARRANTY, OR ALLEGED NEGLIGENCE OR LIABILITY WITHOUT FAULT, SHALL ROSCO BE LIABLE FOR SPECIAL, INCIDENTAL OR CONSEQUENTIAL DAMAGES, INCLUDING WITHOUT LIMITATION, LOSS OF PROFIT OR REVENUE, COST OF CAPITAL, COST OF SUBSTITUTED EQUIPMENT, FACILITIES OR SERVICES, DOWN TIME COSTS, LABOR COSTS OR CLAIMS OF CUSTOMERS, PURCHASERS OR LESSEES FOR SUCH DAMAGES.

---

---

# SPECIFICATIONS - DELUXE ROLLPAC III ROLLER

---

---

## GENERAL:

OVERALL LENGTH .....	73 Inches
OVERALL WIDTH .....	38 Inches
HEIGHT .....	60 Inches (Top of Steering Wheel)
WHEEL BASE .....	50 Inches
ROLLING WIDTH .....	34 Inches (Rear Drum)
WORKING WEIGHT .....	2600 Lbs
CURB CLEARANCE .....	9.60 Inches
WALL CLEARANCE .....	.75 Inches (Right Side)
STATIC APPLIED FORCE (With Drum Ballast)	
Front .....	877 Lbs, 31 Lbs per Lineal Inch
Rear .....	1683 Lbs, 45 Lbs per Lineal Inch
SHIPPING WEIGHT (Dry) .....	1640 Lbs
TURNING RADIUS .....	6 Feet
TRAVEL SPEED .....	0 - 4.75 MPH, Forward or Reverse
SEAT .....	Padded, Weather Resistant with Back Rest
FUEL TANK ..... (HONDA -1.72 US Gallon; KOHLER - 1.25 US Gallon) - Unleaded Regular Gasoline (86 Pump Octane)	
BATTERY .....	12 Volt, 325 CCA
BRAKES .....	Hydrostatic Dynamic Braking - Caliper/Disc Emergency Brake at Rear Drum with Hand Lever
STEERING .....	Automotive Type Mechanical, Full Oscillating
Oscillation .....	24° Total
Fluid Type .....	EP Chassis Lube

## DRUMS:

DRUM DIAMETER	
Front .....	18 Inches
Rear .....	22 Inches
SHELL THICKNESS .....	.375 Inch
STEEL SCRAPERS .....	Steel - Front and Rear

## SPRAYBAR SYSTEM:

TANK .....	Polyethylene, 35 US Gallon, 4 Inch Fill Opening
SPRAYBARS .....	Front & Rear, Plastic Pipe & Rubber Hose
CONTROLS .....	Individual Front & Rear Ball Valves

## HYDROSTATIC DRIVE SYSTEM:

HYD PUMP TYPE .....	Variable Displacement Axial Piston
HYD PUMP MODEL .....	Sunstrand 15 Series
HYD MOTOR MODEL .....	Charlynn 2000 Series
CONTROLS .....	Single, Linear Mechanical Control Lever with Neutral Switch, Forward, Reverse and Dynamic Braking Incorporated
RESERVOIR .....	2 US Gallons
FLUID TYPE .....	See Hydraulic Fluids chart at end of Maintenance Section
FILTER .....	10 Micron Spin-On Type
COOLER .....	Flow-Thru Type

---

---

# SPECIFICATIONS - DELUXE ROLLPAC III ROLLER

---

---

## ENGINES:

TYPE ..... 4-Stroke, Overhead Valve Single Cylinder, Inclined by 25°  
MODEL ..... HONDA, GX390K1  
BORE & STROKE ..... 3.5 x 2.5 Inch (88 x 64 Mm)  
DISPLACEMENT ..... 23.7 Cubic Inch (389 Cc)  
MAX HP @ 3600 RPM ..... 13.0 HP (9.7 Kw)  
OIL CAPACITY ..... 1.16 US Qt  
FUEL CAPACITY ..... 1.72 US Gallons  
IGNITION SYSTEM ..... Electric with Key Switch

TYPE ..... 4 Stroke  
MODEL ..... KOLLER, CH15  
BORE & STROKE ..... 3.55 x 2.64 Inch (9.02 x 6.71 cm)  
DISPLACEMENT ..... 26 Cubic Inch (426 Cc)  
MAX HP @ 3600 RPM ..... 15 HP (11.2 Kw)  
OIL CAPACITY ..... 4 US Pints  
FUEL CAPACITY ..... 1.25 Gallons  
IGNITION SYSTEM ..... Electric with Key Switch

---

---

# INTRODUCTION

---

---

This manual has been compiled to assist the owner and/or operator with the correct operation and routine preventive maintenance procedures for the Deluxe Rollpac III asphalt roller as manufactured by ROSCO / A LeeBoy Company 688 North Highway 16, Denver, North Carolina, USA. also included in this manual to allow for the accurate ordering of repair parts from authorized Rosco dealers/distributors.

THIS MANUAL HAS BEEN ORGANIZED INTO FOUR (4) MAJOR SECTIONS:

PREFACE  
MAINTENANCE

OPERATION  
PARTS CATALOG

A general contents page is located at the beginning of this manual as a quick reference to these sections and their major subsections. In order to receive the performance and efficiency that has been designed into the ROSCO asphalt rollers, it is very important to:

- A. Read this manual thoroughly before operating or servicing the roller.
- B. Keep this manual in a convenient place for ready reference.
- C. **DO NOT** attempt to make repairs or adjustments you do not understand. If you require additional information or service, contact your authorized Rosco dealer/distributor.

Throughout this manual references are made to the LEFT SIDE and RIGHT SIDE of the Deluxe Rollpac III. These terms are used as the roller is viewed from the rear of the machine.

**Serial Number** - It is important to know the serial number of your roller. This serial number plate is located on the upper center on the front of the roller. A space is provided on page 1.7 to record this information. Use the serial number in all correspondence referring to our roller and when ordering parts.

**Technical Information**- ROSCO / A LeeBoy Company is continuously improving its products. The technical information found in this manual was correct at the time it was approved for publication. However, there may be differences between your roller and the information contained in this manual. Please contact your local authorized ROSCO dealer/distributor if you require further assistance.

**Design Specifications** - ROSCO / A LeeBoy Company reserves the right to make design or specification changes without prior notification or to make any other improvements without incurring obligations to add them to any machine in existence.

---

---

# INTRODUCTION

---

---

This manual has been compiled to assist the owner/operator with the correct operation and routine maintenance procedures needed for the safe and efficient use of the ROSCO Deluxe Rollpac III roller. In order to maximize the performance and efficiency of the Deluxe Rollpac III it is **VERY IMPORTANT** that the owner/operator and maintenance personnel read this manual thoroughly before operating or servicing the roller. You must have basic knowledge about the handling of asphalt products and should be trained and licensed per state requirements before operating this equipment. Always keep this manual in a convenient place for instant reference and never attempt to make repairs or adjustments that you do not fully understand. If you require additional information or service, contact your Authorized ROSCO Dealer.

The technical information found in this manual was correct at the time that it was approved for publication. However, due to a continuous program of research and development, some procedures, specifications and parts may be altered in a constant effort to update and improve our products. ROSCO / A LeeBoy Company reserves the right to make design or specification changes without prior notification or to make any other improvements without incurring obligations to add them to any machine in existence. Please contact your local ROSCO Authorized Dealer if you require further assistance.

\*\*\*\*\*

## SERIAL NUMBER PLATE LOCATION

Always give your dealer the Serial Number of your ROSCO Deluxe Rollpac III when ordering parts or when requesting service or other information.

The Serial Number Plate is located on the front of the machine frame, just above the front drum. A space has been provided below to record this information.

MODEL: \_\_\_\_\_

SERIAL NUMBER: \_\_\_\_\_

PRODUCTION YEAR: \_\_\_\_\_



FIGURE 1

---

---

# COMPACTION

---

---

## Principles of Compaction

In general there are two reasons for compacting an asphalt surface. The first reason is to obtain the optimum air void to create a durable surface that can withstand the effects of air, water and temperature changes. Air voids are the spaces in the hot mix not filled by either the aggregate particles of the asphalt cement. Optimum air void should be approximately 2 - 8 % according to The Asphalt Institute recommendations.

The second reason is to provide a smooth surface that will remain smooth under the pressures of traffic.

To accomplish the surface quality mentioned, two conditions must exist. The first is having the correct mix temperature. The Asphalt Institute recommends using asphalt that is between 185° F (85° C) and 300° F (150° C). At this temperature, asphalt will aid in forcing the aggregate into a dense mat. As the mix cools, a dense mat becomes harder to achieve.

The second condition is the confinement of the asphalt. Confinement is achieved by three forces acting on each other. These three forces are: the roller, the mix, and the subgrade under mat. When these three forces act on each other with equal resistance, confinement of the asphalt is reached and compaction is complete.

## The Deluxe Rollpac III Roller

The Rosco Deluxe Rollpac III roller is designed to perform as a static (dead weight) compaction roller. It is a rear drum drive roller. The Deluxe Rollpac III is especially useful when the compaction of asphalt or light sub-bases is needed in areas where large rollers are impractical.

The Deluxe Rollpac III is capable of being tailored for the proper compaction of an area by adding water to the front and/or rear drums as ballast.

To achieve the best compaction results, proper technique and rolling procedures must be followed.

---

---

# SAFETY

---

---

## Safety Alert Symbol

This Safety Alert Symbol means  
ATTENTION ! BECOME ALERT !  
YOUR SAFETY IS INVOLVED !



The Safety Alert Symbol identifies important safety messages on the Rosco Deluxe Rollpac III and in its manual. When you see this symbol, be alert to the possibility of personal injury or death. Follow the instructions in the safety message.

Why is SAFETY important to you?

- 3 Big Reasons:
- \*Accidents Disable and Kill
  - \*Accidents Cost
  - \*Accidents Can be Avoided

## Signal Words

Note the use of the signal words "DANGER, WARNING, or CAUTION" with the safety message. The appropriate signal word for each message has been selected using the following guidelines:

**DANGER** An immediate and specific hazard which **WILL** result in severe personal injury or death if the proper precautions are not taken.

**WARNING** A specific hazard or unsafe practice which **COULD** result in severe personal injury or death if proper precautions are not taken.

**CAUTION** Unsafe practices which **COULD** result in personal injury if proper practices are not taken, or as a reminder of good safety practices.

## Equipment Safety Symbol



Throughout this manual, whenever you see this "broken bolt" symbol, it means:

**CAUTION** - Equipment on the machine could be damaged through improper performance of an operation, maintenance or repair procedure.

---

---

# SAFETY

---

---

**YOU** are responsible for the safe operation and maintenance of your ROSCO Deluxe Rollpac III. You must ensure that you and anyone else who is going to operate, maintain or work around the machine be familiar with the operating and maintenance procedures and all related safety information contained in the manual.

In accordance with OSHA regulations 1928.51 and 1928.52, operating instructions must be provided initially to operators/employees before allowing them to operate the Deluxe, and annually thereafter.

The most **IMPORTANT** safety device on this equipment is a well trained and safe operator. It is his/her responsibility to read and understand all safety and operating instructions in this manual. A person who has not read and understood all operating and safety instructions is not qualified to operate the Deluxe Rollpac III. An untrained operator exposes himself/herself and bystanders to possible serious injury or death. All accidents can be avoided!

**DO NOT** modify the Deluxe Rollpac III in any way. Unauthorized modification may impair function and/or safety, affect the working life of the equipment and void warranty.

**ROSCO / A LeeBoy Company assumes NO LIABILITY for accident or injury incurred through the improper use of this equipment.**

## GENERAL SAFETY PRECAUTIONS

1. Always read and fully understand the Operator's Manual and the Safety Decals on the machine before trying to operate or service this equipment.



2. It is wise to have a first-aid kit available and to be familiar with its contents.



3. Keep a "charged" fire extinguisher within reach whenever you work in an area where fire may occur. Also, be sure you have the correct type of extinguisher for your situation:

Type A: Wood, paper, Textile and Rubbish  
Type B: Flammable Liquids  
Type C: Electrical Equipment



4. Be sure to wear safe work clothing. It should be well fitted and in good repair. Do not wear rings, wrist watches or loose fitting clothing when working on machinery, they could catch on moving parts causing serious injury. Wear sturdy, rough-soled work shoes, safety glasses and any other protective gear that is warranted by the work environment.



5. Keep work area organized and clean. Wipe up oil spills of any kind. Keep tools and parts off floor. Eliminate the possibility of a fall which could result in serious injury.



6. Be sure to reinstall safety devices, guards or shields after adjusting and/or servicing the machine.
7. After servicing, be sure that all tools, parts, or servicing equipment are removed from the vehicle or engine.
8. Wear appropriate ear protection for prolonged exposure to excessive noise. Prolonged exposure to loud noise can cause impairment or loss of hearing.



---

---

# SAFETY

---

---

9. Do not get into a big rush! Use recommended hand holds and steps with at least three points of support when getting on and off the roller.

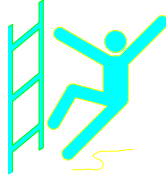

Keep steps, floor, hand holds and controls clean and free from grease. Face the machine when climbing up and down and never jump off the roller or dismount while the machine is in motion.

10. Do not permit riders on the roller. A rider may be injured by being thrown from the unit or being struck by objects. A rider also obstructs the operator's view which results in an unsafe operating condition.

11. DO NOT SMOKE around machine.

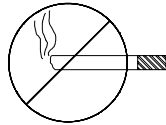

12. DO NOT add any additional components to this equipment. Rosco Manufacturing Company cannot warrant any component or system that has been altered from its original design configuration.

13. DO NOT modify the equipment in any way. Unauthorized modification may impair the function and/or safety and could affect the life of the equipment.

14. DO NOT weld or bring flame near the fuel tank, fuel system, oil reservoirs or battery. Flame or sparks in any of these areas may cause fire or explosion.



## HOT MATERIAL PRECAUTIONS

1. Wear protective gear for face, hands, feet and body when operating the roller.

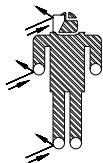

2. Allow machine to cool before repairing or servicing working components. Hot surfaces may cause burns to the skin.

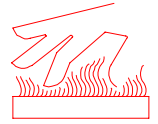

3. When hot asphalt touches skin, flush area immediately with cold water. Get medical attention!

## HYDRAULIC SYSTEMS PRECAUTIONS

1. Make sure that all components are in good working condition. Replace any worn, cut, abraded, flattened or crimped hoses and metal lines.

2. Do not attempt makeshift repairs using tape, clamps or cements. The hydraulic system operates under extremely high pressure and such repairs could cause serious injury.

3. Wear proper hand and eye protection when searching for a high pressure leak. Use a piece of wood or cardboard as a back stop instead of hands to isolate and identify leaks.



4. If injured by concentrated high pressure steam or hydraulic fluid, seek medical attention immediately. Fluid injected into the skin must be surgically removed within a few hours by a doctor familiar with fluid injection injuries or gangrene may result.



## REFUELING PRECAUTIONS

1. Refuel in a well-ventilated area with engine stopped. Do not smoke or allow flames or sparks in the area where the engine is refueled or where gasoline is stored.

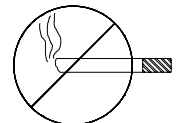

---

---

# SAFETY

---

---

## REFUELING PRECAUTIONS (cont.)

2. Do not overfill the fuel tank - overflow creates a fire hazard. After refueling, make sure tank top is closed properly and securely.
3. If fuel is spilled, make sure the area is dry before starting engine.
4. Keep out of reach of children!
5. DO NOT over fill fuel tank. Allow room for expansion.
6. Tighten the fuel tank cap securely. If cap is lost, replace it only with the original manufacturer's approved cap. A non-approved cap without proper venting may result in pressurization of the tank.



## BATTERY PRECAUTIONS

1. Keep all sparks and flames away from batteries, as gas given off by electrolyte is explosive.
2. If you come in contact with battery electrolyte solution wash off immediately.
3. Always disconnect the battery ground cable before working on the electrical system.
4. Do not tip batteries more than 45 degrees, to avoid electrolyte loss.
5. Use jumper cables ONLY in recommended manner. Improper use can result in battery explosion or unexpected roller motion.

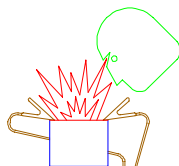

## STARTING AND STOPPING

1. Walk around the roller and be sure to warn all personnel in the area before starting the roller. Be sure the area is clear before starting.
2. Check all controls in a safe area before starting work.
3. Only start or operate the machine from the operator's seat.
4. Check to be sure the parking brake is applied and the forward/reverse control is in the neutral position BEFORE starting the Deluxe Rollpac III.
5. Do Not bypass the neutral-start system. The system must be repaired if it malfunctions.
6. Do Not operate the engine in an enclosed area without adequate ventilation. Exhaust gasses contain carbon monoxide, an odorless and deadly poison.
7. Always park the Deluxe Rollpac III on level ground whenever possible. Apply the parking brake. On grades, park the machine with the rollers securely blocked.
8. Before dismounting the unit, place the forward/reverse handle in neutral, turn off all accessories, set the parking brake and shut off the engine. Remove the ignition key when leaving the unit.

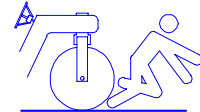

## ROLLER OPERATION PRECAUTIONS

1. Do not allow the roller engine to run for long periods of time when the roller is not in use.
2. Do not run engine in an enclosed area. Exhaust gasses contain carbon monoxide, an odorless and deadly poison.

---

---

# SAFETY

---

---

## ROLLER OPERATION PRECAUTIONS (cont.)

3. Do not reverse direction of the roller without checking that there are no obstacles or people in the path of the roller.
4. Do not operate the Deluxe Rollpac III if the air cleaner cover has been removed.
5. Wear safety orange reflector-type vests and protective clothing when operating the roller.
6. Inspect all hydraulic lines, linkages, fittings and couplers tight and free of leaks and foreign material before each days use.
7. Do not service the engine or the hydraulic system with the engine running. Shut down the engine and allow rotating parts to completely stop before servicing the equipment.
8. Do not go under the vehicle when the engine is running.
9. Place all controls in neutral, stop engine, set park brake, remove ignition key and wait for all moving parts to stop before servicing, adjusting, repairing or unplugging.
10. Keep hands, feet, hair and clothing away from moving parts.
11. Do not push the roller to start the engine.
12. DO NOT operate the roller from the ground. Mount the machine and become fully seated before starting.
13. Always follow the pre-start instructions before operation. Be sure all controls and gauges are operating properly before starting the job. DO NOT operate the Deluxe Rollpac III if any of the warning buzzer/lights are "ON". If any malfunctions are found prior to or during operation, shut down the machine and report the problem to be repaired.

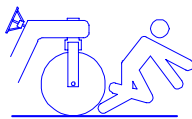
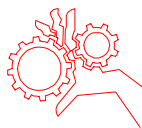

14. If the operator loses any of the controls such as steering or engine, stop the machine motion as quickly as possible. Apply the park brake, turn off the engine, and block the rollers until the unit can be repaired or safely towed away.
15. Drive the Deluxe Rollpac III at speeds compatible with the conditions. Special care should be taken on slopes, inclines, over rough ground or when turning. Note and avoid hazards such as ditches, underground lines, trees, cliffs, etc. The roller is for use on highway grades ONLY.
16. DO NOT use the throttle to govern speed of the roller. Operate at full throttle and use forward/reverse lever to control speed, direction and braking.
17. Know and use the hand signals required for each job and know who has the responsibility for signaling.
18. Know and understand the job site traffic flow patterns and obey flagmen, road signs and signals.
19. Operate the roller in construction areas only. Use extreme caution when operating near other vehicles or personnel.
20. DO NOT operate on soft shoulders of the road. Soft shoulders could collapse, causing the machine to roll over.

## BRAKING PRECAUTIONS

1. Stopping distances must be anticipated carefully for all conditions. If stopping on a grade, the distance to come to a stop will be longer the steeper the grade. Familiarize yourself with these variables so you anticipate when a longer stopping distance is required.

---

---

# SAFETY

---

---

## TRANSPORT PRECAUTIONS

1. Always comply with local regulations regarding moving equipment on public roads and highways.
2. Make sure that all lights and reflectors comply with state and local regulations. Make sure that they are clean, in good working order and can be seen clearly by all overtaking and oncoming traffic.
3. Do not tow the machine without first removing the drive chain. Towing should be limited to lower speeds and emergency situations only. Close Engine Fuel Valve before towing or transporting the roller.

## MAINTENANCE PRECAUTIONS

DO NOT attempt repairs unless trained. Refer to manuals and experienced repair personnel.

1. Follow ALL operating, maintenance and safety information in the manual.
2. Support the machine with blocks or safety stands when working beneath it.
3. Place all controls in neutral, stop engine, remove ignition key and wait for all moving parts to stop before servicing, adjusting or repair.
4. Follow good shop practices: Keep service area clean and dry. Be sure electrical outlets and tools are properly grounded. Use adequate light for the job at hand.
5. Make sure all guards are in place and properly secured when maintenance work is completed.



6. Before applying pressure to a hydraulic system, make sure all lines, fittings, and couplers are tight and in good condition.

7. Wear protective glasses and other required safety equipment when servicing or repairing the Deluxe Rollpac III.

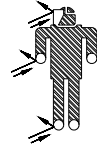

8. Keep hands, feet, hair and clothing away from moving parts.

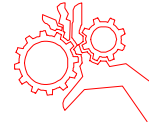

9. Clear the area of bystanders when carrying out any maintenance and repairs or making any adjustments.

10. Avoid servicing the Deluxe Rollpac III while in motion or with engine running. If the engine must be running to service a component, place Forward/Reverse control in neutral, apply park brake, block rollers and use extreme caution.

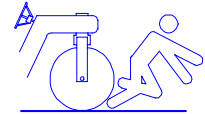

11. DO NOT make repairs on pressurized components fluid, gas or mechanical, until the pressure has been properly relieved. Use extreme caution when removing radiator caps, drain plugs, grease fittings or pressure caps.

12. Keep all fluids at proper operating levels. Make sure cooling system fins are clean and proper tension is maintained on all belts.

13. Keep the hydrostatic drive and steering systems in good operation.

## STORAGE PRECAUTIONS

1. Store the machine in an area away from human activity.
2. Do not permit children to play on or around the stored machine!

---

---

# SAFETY

---

---

## STORAGE PRECAUTIONS (cont.)

3. Make sure the unit is stored in an area that is firm, level and free of debris.
4. Store the machine inside a building or cover securely with a weatherproof tarpaulin.



---

---

# SAFETY DECALS

---

---

## SAFETY DECAL MAINTENANCE

1. Keep safety decals and signs clean and legible at all times. Replace decals and signs that are missing or become impossible to read.
2. When replacing parts that previously displayed a safety decal, be sure to replace the decal as well.
3. Obtain safety decals or signs from your authorized Rosco dealer.
4. Become familiar with the content and the position of each safety decal. Important information is written on the decals. The location and description of each safety decal is described on pages 1.17-1.18.
7. If the decal has a protective top paper, use hot soapy water on the surface to which the decal is being applied. Leave wet. After deciding on the location, remove the backing paper and soak the decal in clean soapy water before application. This will help to alleviate air bubbles in the finished decal.
8. Smooth the decal into place with a squeegee, and check for air bubbles. Small air pockets may be pierced with a pin and smoothed out. When the decal is completely smoothed out, carefully remove the top paper.

## DECAL INSTALLATION

1. Be sure that the installation area is clean and dry. Use hot soapy water and dry area thoroughly before installing decals.
2. Decide on the exact position by making measurements and test fitting before you remove any of the backing paper.
3. For decals with no top paper, decide on the location for the decal and remove the smallest portion of the split backing paper.
4. Align the decal over the specified area and carefully press the small portion with the exposed adhesive backing in place.
5. Slowly peel back the remaining paper and carefully smooth the remaining portion of the decal in place.
6. Small air pockets can be pierced with a pin and smoothed out using the piece of decal backing paper.

# SAFETY DECALS



For safety and efficiency it is the responsibility of the customer or users management to train, educate and supervise his employees in the proper operation and maintenance of this equipment.  
Read and understand operation instructions in manual.

72681

**WARNING DECAL #72681  
TOP COVER - NEXT TO EMERGENCY BRAKE**

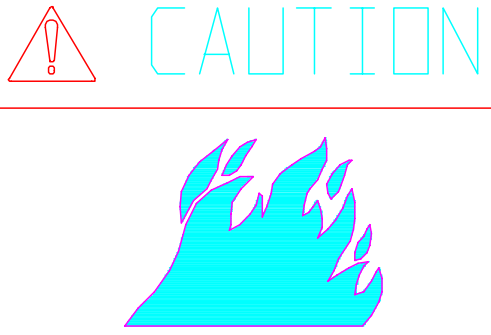

FIRE can be caused by leaking fuel.  
CLOSE fuel valve prior to transporting or when roller is not in use.

72676

**CAUTION DECAL #72676  
INSIDE FRONT COVER**

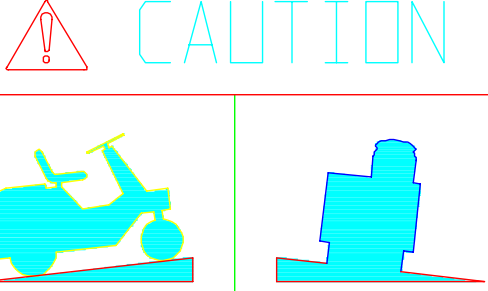

Operation on grades may cause loss of control or roller to tip over.  
DO NOT operate on grades over 15 %

72679

**CAUTION DECAL #72679  
STEERING COLUMN**

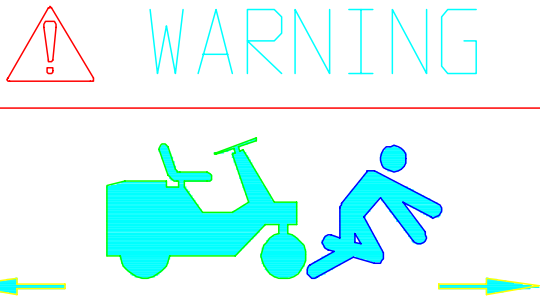

DO NOT move transmission lever while engine is not running.  
Neutral position on transmission could be lost and roller may creep.

72683

**WARNING DECAL #72683  
TOP COVER - NEXT TO CONTROL LEVER**

DO NOT change travel direction with fast movements of the lever, failure of hydraulic system will result and warranty will be void.

72687

**#72687  
TOP COVER - NEXT TO CONTROL LEVER**

# SAFETY DECALS

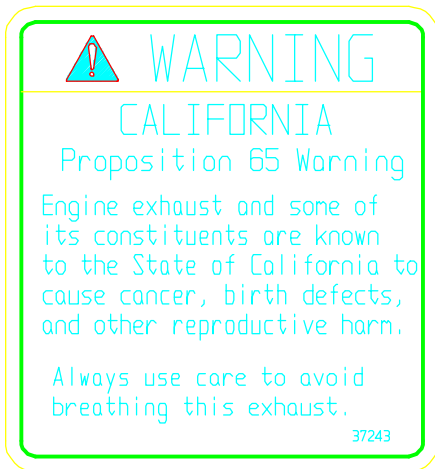

**WARNING DECAL #37243  
 STEERING COLUMN**

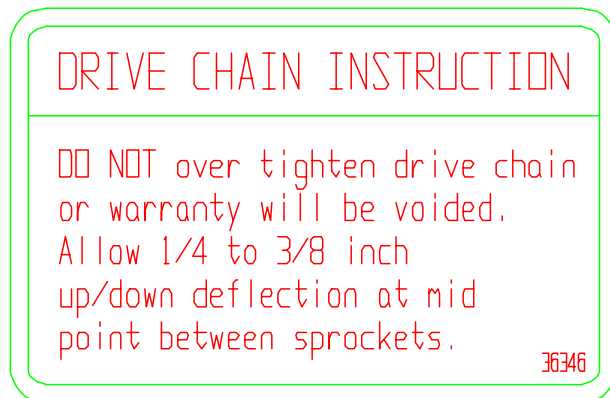

**#36346  
 INSIDE FRONT COVER**

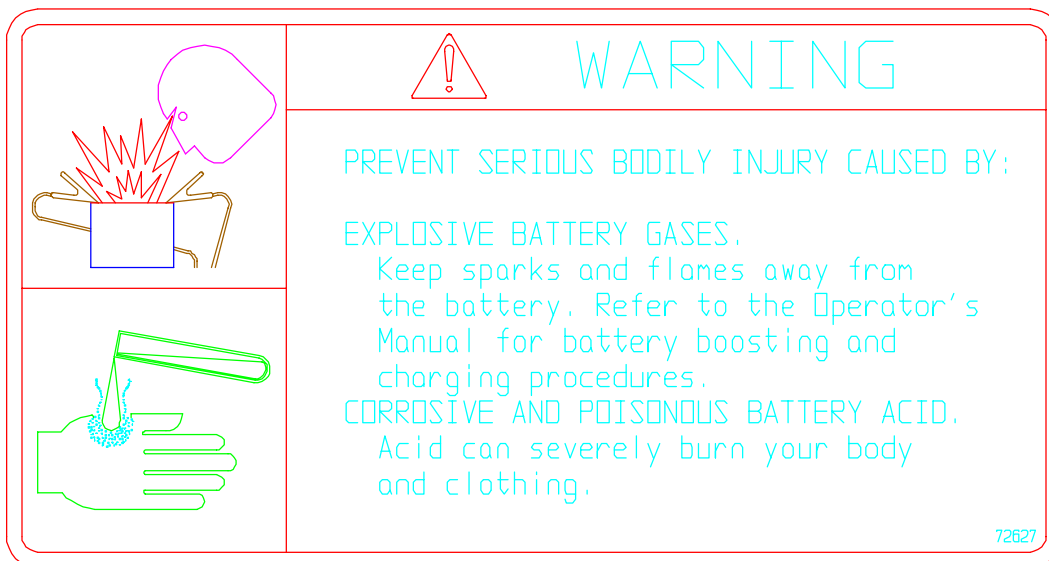

**WARNING DECAL #72627 - INSIDE FRONT COVER**

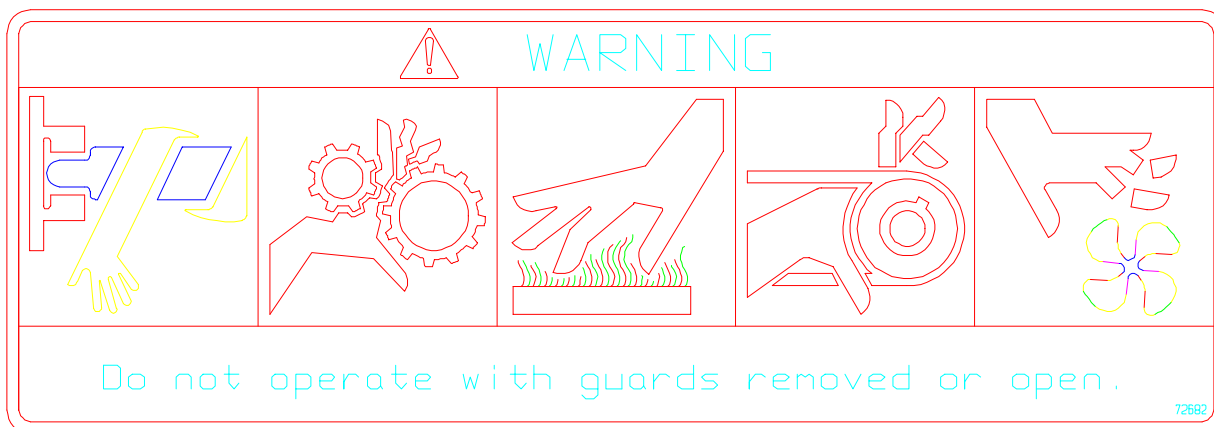

**WARNING DECAL #72682 - INSIDE FRONT COVER**

# SECTION II

## OPERATION

1. GENERAL .....	2.3
2. PRE-OPERATING CHECK LIST .....	2.3
3. START-UP AND OPERATION .....	2.3 - 2.4
4. SPRAYBAR WATER SYSTEM .....	2.4 - 2.5
5. DRUM BALLAST .....	2.5
6. SHUTDOWN PROCEDURE .....	2.5
7. STATIC STEEL DRUM ROLLERS .....	2.5
8. ROLLING PATTERN .....	2.6
9. COMBATING POOR VISIBILITY .....	2.6



---

---

# OPERATION

---

---

## GENERAL

It is important that the ROSCO Deluxe Rollpac III owner/operators fully understand the controls and components of this equipment. An understanding of the operating procedures included in this manual will insure safe operation and efficient use of the Deluxe Rollpac III.

The Deluxe Rollpac III is designed to perform as a static compaction roller.

## PRE-OPERATING CHECK LIST

1. Check engine oil. Add oil if low. Be careful not to overfill.
2. Check hydraulic reservoir. Add fluid if low.
3. Check engine gas tank. Fill if necessary.
4. Grease front axle and rear drum bearings.
5. Check the engine air intake areas. Make sure they are clean and free of obstruction.
6. Check that all shrouds and covers are in place.

7. Check spray bar water tank. Fill if necessary.
8. Check drive chain tension.
9. Check Park/Emergency brake adjustment.
10. *OPEN* fuel line valve.

## START-UP AND OPERATION

1. The operator should be seated, not standing, when starting the machine.
2. Make sure that the **Transmission Control Lever** is in the "*Neutral Position*" (center) as indicated by the Control Lever Decal.
3. Pull the **Throttle Control** out to the mid point of its travel.
4. Pull the **Choke Lever** all the way to a full choke position for initial starting.

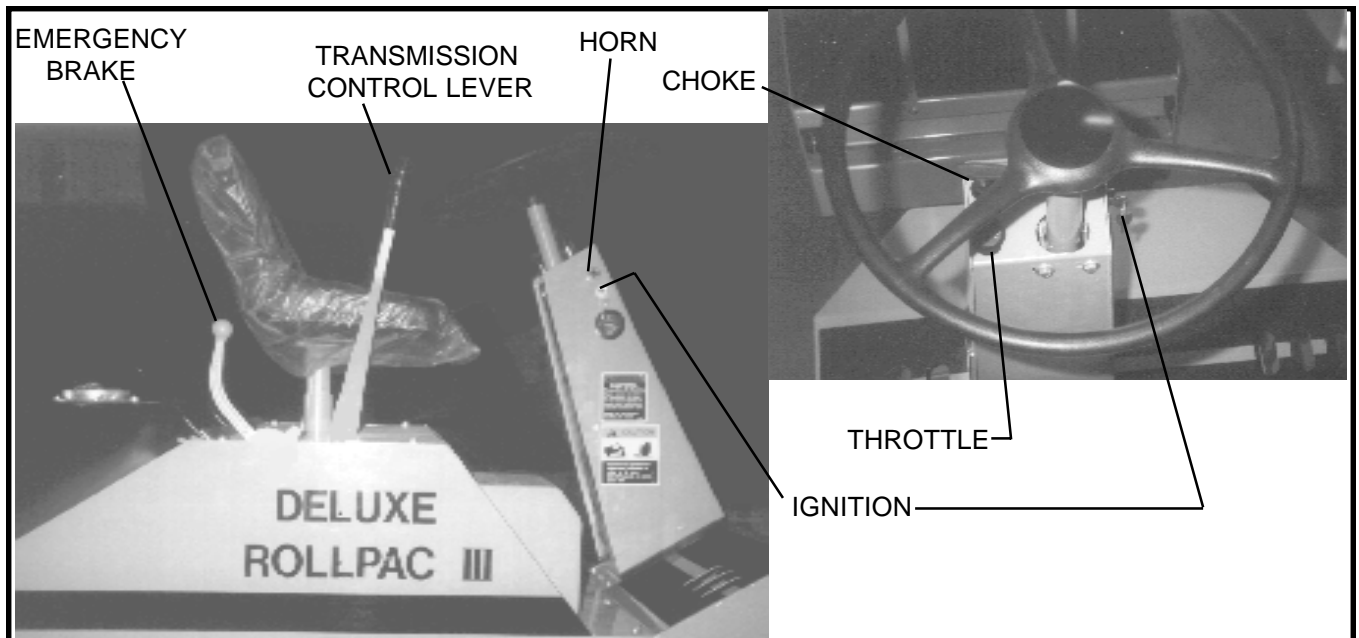

FIGURE 1 - Controls

---

---

# OPERATION

---

---

## START-UP AND OPERATION (cont.)

5. Turn the **Ignition Key** and start the engine. As soon as the engine starts, release the key.



**ATTENTION:** *In the event that the engine does not start immediately, do not crank the engine for more than 10 seconds at a time. Allow the starter to cool down for 60 seconds after several attempts to start engine. Failure to follow these guidelines may result in starter motor burnout.*

6. In the event of a "false start" (the engine develops enough speed to disengage the starter but fails to continue running) allow the engine to completely stop before restarting. If starter is engaged while the flywheel is still rotating, the starter pinion and flywheel ring gear may clash, resulting in damage to the starter or ring gear.
7. Maintain a slow engine RPM for approximately one to five minutes which allows the hydraulic system to warm-up before moving.
8. Gradually push the **Choke Lever** to the "OFF" position as the engine warms and the choke is no longer needed. When the engine is able to run without the assistance

of the choke, the roller is sufficiently warm and is ready to be used.

9. Release the Park/Emergency Brake Lever (OFF position) before attempting to move the roller.

**NOTE:** *Cold weather operation may require that the brake be released before starting the engine.*

10. Travel speed and the direction of travel is controlled by the **Transmission Control Lever**. Always move the Control Lever from one direction through Neutral to the opposite direction with **SLOW** movements. Following this procedure utilizes the hydraulic system's dynamic capability to bring the machine's weight to a complete stop, at Neutral, before going in the opposite direction, thereby preventing damage to the system and avoiding injury to the operator.
11. Do not set the engine speed (RPM) higher than needed for the requirements of the job. Make sure that the engine RPM setting does not cause excessive engine vibration.
12. If the engine is lugging down during a heavy pull (forward or reverse direction) move the Control Lever towards Neutral to decrease speed and increase torque to the final drive.

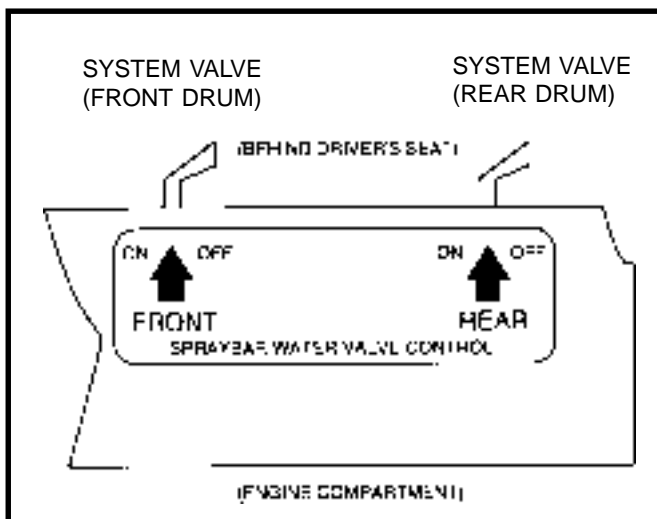

FIGURE 2 - Spraybar Water System Valves

## SPRAY BAR WATER SYSTEM

The **Spray bar Water System** provides water to the front and rear drums. The water prevents asphalt material from sticking to the drums during operation. The Water Tank, located at the rear of the roller, is the water supply for the Spray bar system.

The **Spray bar Water System Valves**, one for each drum, are located on the engine cover directly below the operator's seat. Water is provided to the front and/or rear spray bars by opening or closing these valves.

---

---

# OPERATION

---

---

## SPRAY BAR WATER SYSTEM (cont.)

To drain the Water Tank, open the system valves and drain through the spray bars. If it is necessary to drain into a container, remove the hose at the front Spray bar and direct the water into the container opening.



**CAUTION** - Do not fill Water Tank with any liquid other than Water.



**ATTENTION** - Drain the Water Tank if freezing temperatures are anticipated to prevent damage to tank.

## DRUM BALLAST

Filling the front and/or rear drums with water adds weight and allows for greater compaction. A plug is located on the outer end of each front drum and access to the plug on the rear drum is through the large clearance hole located in the left side of the machine.

When filling the drums, rotate them so that the plug in the end of the drum is located at the top. Remove the plug, fill, replace plug and tighten securely.

**BE SURE TO FILL BOTH FRONT DRUMS EQUALLY.** Failure to do so will result in uneven compaction and the machine being out of balance.

To drain the drums, rotate them so that the plug is located at the bottom, nearest to the ground. Remove the plug, drain, replace plug and tighten securely.



**ATTENTION** - Drain the drums if freezing temperatures are anticipated. Failure to do so can cause permanent damage to the drums. A mixture of 50% water and 50% alcohol, or the equivalent, should be used for operation during freezing temperatures (below 32° F).

## SHUT DOWN PROCEDURE

1. Move the **Transmission Control Lever** to the "Neutral" position.
2. Engage **Park/Emergency Brake Lever (ON)**.
3. Idle down the engine. Allow it to run for 1-5 minutes to cool off. Units equipped with the Kohler engine will back fire if shut off while hot.
4. Turn "OFF" the **Ignition Key**.
5. Close the Engine Fuel Valve.  
**Note:** Always close the Engine Fuel Valve when towing or transporting roller.
6. Remove the ignition key to prevent unauthorized operation of roller.

## STATIC STEEL DRUM ROLLERS

Static steel drum rollers can be used in all phases of asphalt compaction. When the first break down pass is being performed, be sure that the drive - wheel is ahead of the tiller wheel in the direction of travel. The larger size and weight of the drive - wheel forces the mix under the roller instead of pushing it ahead of the roller as the tiller wheel is prone to doing. The drive - roller, by being larger in diameter, presses with a flatter surface on the mix and will not sink in the fresh mat as easily as the tiller wheel.

The weight and size combine to provide for optimum compaction and should be used first as the best time to compact the mix is while it is fresh and hot. Using the drive - roller first will also help prevent heat checking and other slippage distress in the fresh mat. Follow your established rolling pattern through all passes; first, intermediate and finish. An exception this rolling procedure is when the roller is operating uphill. Then the drive wheel should be at the rear because of the added traction.

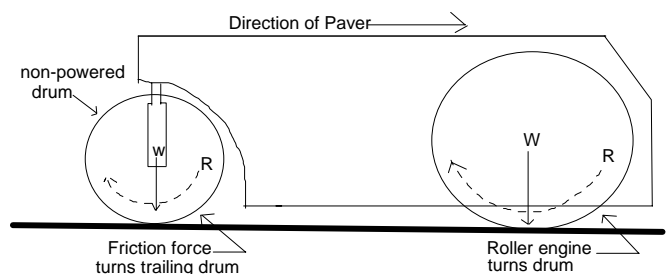

---

---

# OPERATION

---

---

## ROLLING PATTERN

One rolling pattern for all rollers would be impractical. Rollers vary in width and therefore a pattern for each roller should be worked out prior to the paving operation using a test strip of the same mix that will be used on the job. Roller speed should not exceed 3 mph (5 Km/hr).

When compacting thick lifts, be sure to start rolling 12 to 15 inches (300 to 375 mm) from the unsupported edge. This allows compaction to the center material first so there is more stability for the roller as it moves towards the edges. The uncompacted edge helps with the confinement of the asphalt during the first passes. After the central area of the spread is compacted, the edge may be compacted without lateral movement.

For a thin lift, a recommended pattern is shown. Each pass of the roller should proceed in a straight direction of travel into the mix. Each return pass should be in the same path as the forward path. Overlap each pass 3 to 4 inches (75 to 100 mm). Be sure each path extends further into the mix than the previous path. When the width of the lane has been finished, swing the roller across the mat on cooled material and repeat.

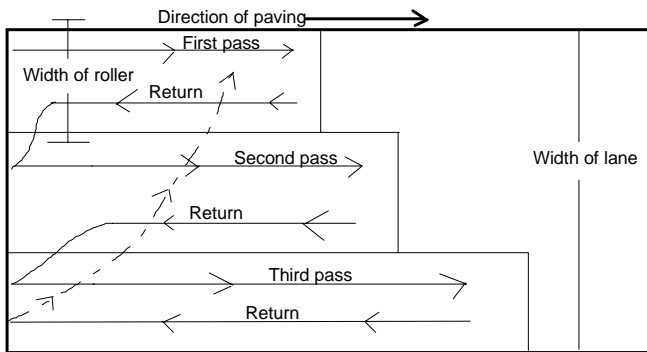

--- After the required number of passes are completed, swing to the outside on cool material and repeat.

## COMBATING POOR VISIBILITY

Increasingly, asphalt maintenance equipment is being used during poor visibility conditions, such as fog, smog and at night. Usage during this and other similar types of conditions presents safety hazards to the workers, bystanders and passing traffic. People can be injured or killed by the equipment, passing traffic or driving into ditches, holes or down embankments and other obstructions. To help combat these hazards, the equipment must be equipped with front and rear lighting options as well as back up lights. They must also be equipped with shielded, rotating beacons. The shielding prevents loss of visibility to the operator caused by eye strain. Use conspicuous tape (reflective) on the sides of all machines that may be used at night. Also be sure that all personnel wear reflective vests. The use of impact barriers (movable or stationary) to protect the workers from traffic and help direct the traffic flow away from road hazards is also recommended.

# SECTION III

## MAINTENANCE

1.	GENERAL .....	3.3
2.	ENGINE MAINTENANCE .....	3.3 - 3.12
	Fuel .....	3.3
	Engine Oil (HONDA) .....	3.4
	Engine Oil Change (HONDA) .....	3.4
	Engine Oil (KOHLE) .....	3.5
	Engine Oil Change (KOHLE) .....	3.6
	Engine Air Cleaner (HONDA) .....	3.7
	Engine Air Cleaner (KOHLE) .....	3.8
	Engine Air Intake .....	3.9
	Engine Spark Plug .....	3.9
	Engine Sediment Cup .....	3.10
	Engine Carburetor (HONDA) .....	3.10
	Engine Carburetor (KOHLE) .....	3.11
	Engine Battery .....	3.11 - 3.12
4.	DRIVE SYSTEM MAINTENANCE .....	3.13 - 3.16
	Hydraulic System .....	3.13 - 3.14
	Transmission Control Lever .....	3.15
	Drive Chain Adjustment .....	3.16
	Re-Centering Sprocket .....	3.17
5.	CHASSIS MAINTENANCE .....	3.18
6.	PARK/EMERGENCY BRAKE MAINTENANCE .....	3.18 - 3.19
7.	STORAGE .....	3.19 - 3.21
8.	HYDRAULIC FLUIDS .....	3.22
9.	HYDRAULIC FITTING TORQUE .....	3.23
10.	BOLT TORQUE CHART .....	3.24
11.	TROUBLE SHOOTING .....	3.25 - 3.26
12.	PREVENTIVE MAINTENANCE CHARTS .....	3.28 - 3.29



---

---

# MAINTENANCE

---

---

## GENERAL

The suggestions and recommendations contained in this section for maintenance should be followed as closely as possible to obtain long life and best performance from your Deluxe Rollpac III.

**Properly Maintained Equipment is Safe Equipment!** It is the operator's responsibility to make daily inspection of the Deluxe Rollpac III for loose bolts, fluid leaks, worn or damaged hoses and debris or dirt accumulation which can cause a potential problem.



**WARNING** - *The Direction Control Lever must be in NEUTRAL and the PARK/EMERGENCY BRAKE engaged before any service or maintenance is attempted on the roller.*

**A Preventive Maintenance Chart** is included at the end of this section as a guide for establishing a Preventive Maintenance Schedule. The maintenance procedures included on the chart should be performed as often as indicated. If the Deluxe Rollpac III is operated under extremely dirty or dusty conditions, maintenance should be performed more frequently.

---

## ENGINE MAINTENANCE

*The following instructions are excerpts from the Kohler and Honda engine manuals. The appropriate manual for your machine is included with your unit. For more detailed information, see your engine manual and read all manuals carefully before operating your machine.*

### Fuel

- a. Both manufacturers recommend the use of unleaded gasoline because it leaves fewer engine combustion chamber deposits. Use gasoline with a pump sticker rating of 87 or higher.
- b. Never use stale or contaminated gasoline. Never add oil to the gasoline.
- c. Only Kohler has approved gasohol (up to 10% ethyl alcohol, 90% unleaded gasoline) for use in its' engine. Honda does not approve gasohol for its' engine. Other gasoline/alcohol blends are not recommended.

### Fuel (cont.)

- d. Only Kohler has approved the use of Methyl Tertiary Butyl Ether (MTBE) and unleaded gasoline blends (up to a maximum of 15% MTBE). Other gasoline/ether blends are not recommended.



**WARNING:** *Gasoline is extremely flammable. Its vapors can cause explosion if ignited. Store gasoline only in approved containers, in unoccupied buildings, away from sparks and flames. Do not add gasoline to the fuel tank while the engine is hot or running. Do not start the engine around spilled fuel. Never use gasoline as a cleaning agent.*



- WARNING:** *Do not Smoke while fueling the unit or if gasoline vapors may be present! An explosion can occur.*
- e. For more information about fuel requirements and engine warranty, see the engine owners manual included with your unit.

# MAINTENANCE

## Engine Oil - HONDA (Figures 1 & 2)

- Use a high detergent, premium quality motor oil certified to meet or exceed U.S. automobile manufacturer's requirements for Service Classification SG, SF. SAE 10W/30 or 10W/40 is recommended for general, all temperature use. See Figure 1 for the viscosities required at different temperature extremes.
- Be sure the engine is in a level position.
- Remove the oil filler cap/dipstick and wipe clean.
- Insert the filler cap/dipstick into the oil filler neck but do not screw it in.
- If level is low, fill to the top of the oil filler neck with the recommended oil.
- Reinstall the oil filler cap/dipstick.

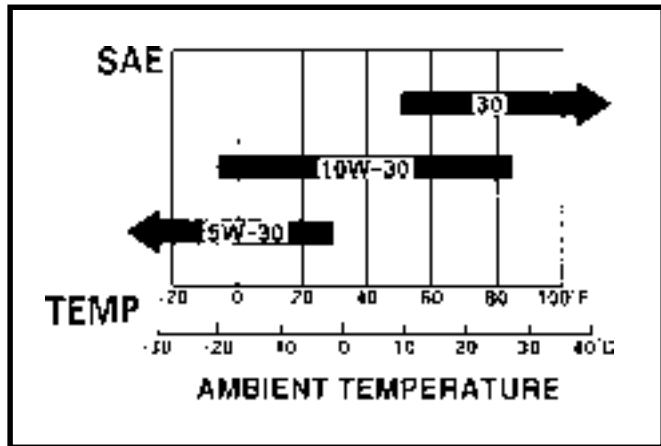

FIGURE 1 - Engine Oil Viscosity

- Reinstall the drain plug (with sealing washer) and tighten securely.
- Refill with the recommended oil and check the oil level (1.16 US Qt, 0.97 Imp Qt).
- Reinstall the oil filler cap.
- Please dispose of the used motor oil in a manner that is compatible with the environment. Do not throw it in the trash or pour it on the ground.

## Engine Oil Change - HONDA (Figure 2)

- Drain the oil while the engine is still warm to assure rapid and complete draining.
- Remove the oil filler cap and drain plug (with sealing washer) and drain oil into a suitable container.

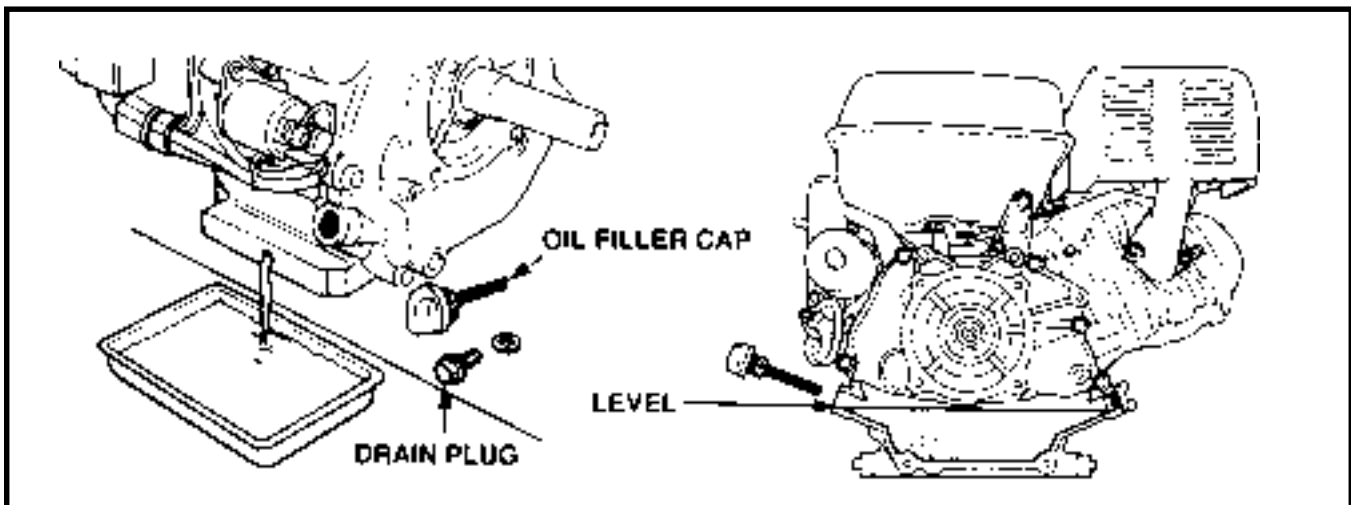

FIGURE 2 - Engine Oil Level Change & Check

# MAINTENANCE

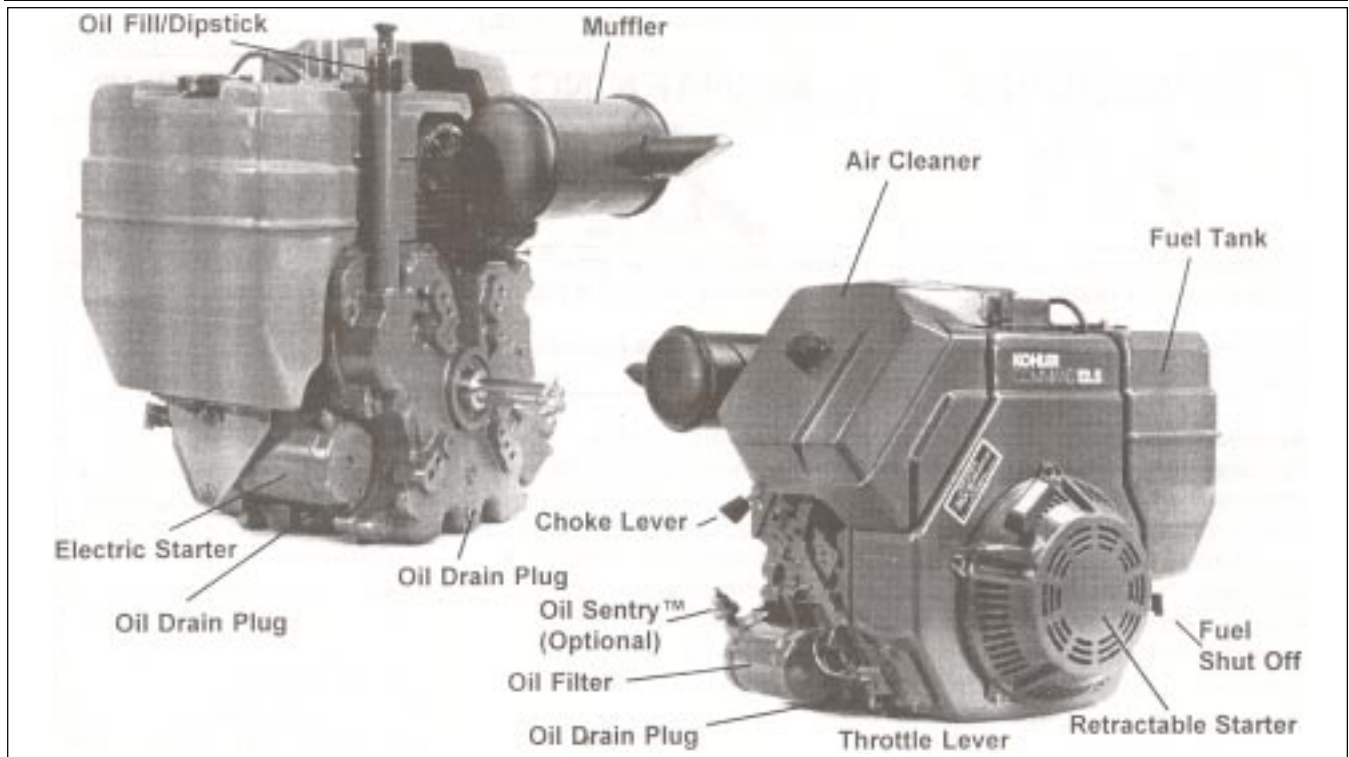

FIGURE 3 - Typical Kohler Engine

## Engine Oil - KOHLER (Figure 4)

- a. Use a high quality detergent oil. The oil should have a API (American Petroleum Institute) service grade of SG or SH. Select the viscosity based on the air temperature at the time of operation as shown in the following table.

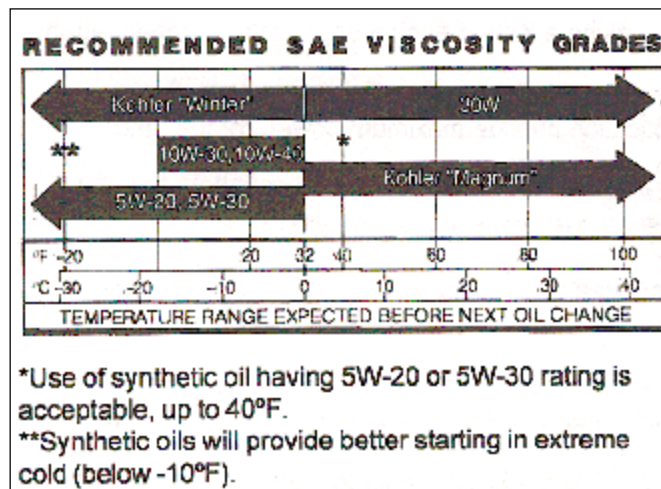

FIGURE 4 - Viscosity Grades Table

- b. To Check Oil Level:  
 Stop unit on a level place. Set park brake. Shut off engine and remove ignition key. Allow engine to cool so the oil will drain into the sump.
- c. Clean area around oil fill cap/dipstick before removing it. This prevents dirt from entering the engine.
- d. Remove the oil fill cap/dipstick; wipe off. Reinsert the dipstick into the oil fill tube and press onto the tube.
- e. Remove dipstick again and check oil level. Oil should be between the "L" mark and the "F" mark.



**ATTENTION:** If the oil level is below the "L" mark, add oil to the proper level. If it is above the "F" mark, drain some oil to achieve the proper level. Be sure to always operate machine with the oil level at the proper operating range to prevent engine wear or damage.

---

---

# MAINTENANCE

---

---

## Change Oil & Filter - KOHLER (Figure 3)

For new engines, change the oil after the first *5 hours* of operation. Then, change the oil after every 100 hours.

Change the oil while the engine is warm. Warm oil will flow more freely and carry away more impurities.

- a. To Change Oil:  
Be sure the unit is parked on a level surface, the park brake is set and the ignition key is removed.
- b. Remove the oil drain plug and fill cap/dipstick. Completely drain the oil from the engine.
- c. Reinstall the drain plug and tighten to 13.6 N·m (10 ft.lb.) torque.
- d. Fill the crankcase, with new, proper type oil, to the "F" mark on the dipstick. Always check the level on the dipstick before adding more oil to avoid overfilling.
- e. Reinstall the oil fill cap/dipstick and tighten.
- f. Please dispose of the used motor oil in a manner that is compatible with the environment. Do not throw in the trash or pour it on the ground.



**ATTENTION:** *If the oil level is below the "L" mark, add oil to the proper level. If it is above the "F" mark, drain some oil to achieve the proper level. Be sure to always operate machine with the oil level at the proper operating range to prevent engine wear or damage.*

Replace the oil filter at least every other oil change (200 hours).

- g. To Change the Oil Filter:  
Drain the oil from the engine crankcase and allow the filter to drain.

- h. Remove the old filter and wipe off the filter adapter.
- i. Apply new oil in a thin coating to the rubber gasket on the new filter.
- j. Install the new filter, turning the filter clockwise until the rubber gasket makes contact with the filter adapter. Then tighten an additional  $\frac{1}{2}$  turn.
- k. Reinstall drain plug.
- l. Fill the crankcase with new oil as directed in the "To Change Oil" instructions. Add an additional .24 L ( $\frac{1}{2}$  pint) of oil for the filter capacity.
- m. Start the engine and check for leaks. Correct any leaks before putting the machine in operation.



**ATTENTION:** *If the oil level is below the "L" mark, add oil to the proper level. If it is above the "F" mark, drain some oil to achieve the proper level. Be sure to always operate machine with the oil level at the proper operating range to prevent engine wear or damage.*

---

---

# MAINTENANCE

---

---

## Air Cleaner Service - HONDA(Figure 5)



**ATTENTION** - Never run the engine without the air cleaner. Rapid engine wear will result from contaminants being drawn through the carburetor into the engine.

A dirty Air Cleaner will restrict air flow to the carburetor. To prevent carburetor malfunction, service the Air Cleaner regularly. Service more frequently when operating the engine in extremely dusty areas.

- a. Remove the wing nut and the Air Cleaner cover. Remove the elements and separate them. Carefully check both elements for holes or tears and replace if damaged.
- b. *Foam Element:* Wash the element in a solution of household detergent and warm water, then rinse thoroughly, or wash in nonflammable or high flash point solvent. Allow the element to dry thoroughly.



**WARNING** - Never use gasoline or low flash point solvents for cleaning the air cleaner element. A fire or explosion could result.

Soak the element in clean engine oil and squeeze out the excess oil. The engine will smoke during initial start-up if too much oil is left in the foam.

- c. *Paper Element:* Tap the element lightly several times on a hard surface to remove excess dirt or blow compressed air through the filter from the inside out. Never try to brush the dirt off; brushing will force dirt into the fibers. Replace the paper element if it is excessively dirty.

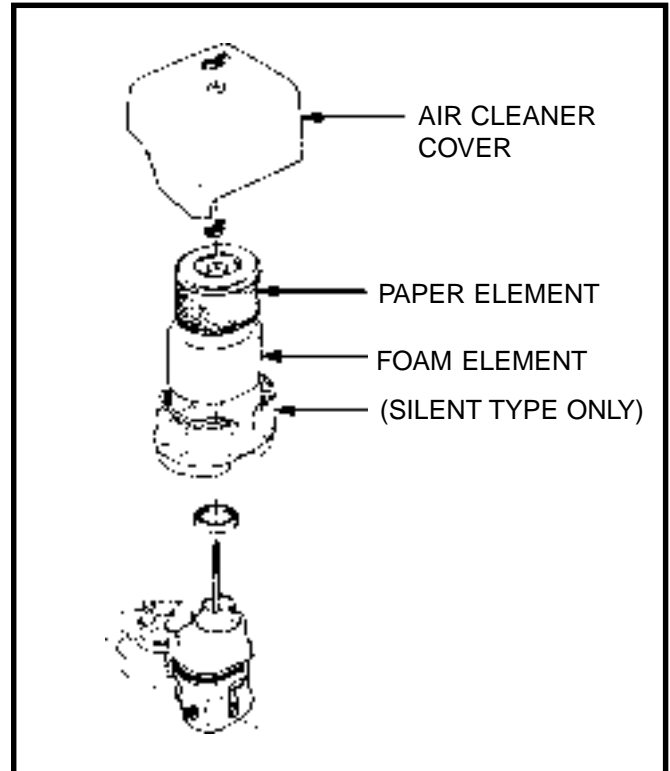

FIGURE 5 - Air Cleaner Service

---

---

# MAINTENANCE

---

---

## Air Cleaner Service - KOHLER (Figure 6-7)

Check the air cleaner daily or before starting the engine. Check for buildup of dirt and debris around the air cleaner system. Keep this area clean. Also check for loose or damaged components. Replace all bent or damaged components.



**ATTENTION:** *Operating the engine with loose or damaged air cleaner parts could allow unfiltered air into the engine causing premature wear and breakdown.*

Wash and reoil the precleaner every 25 hours of operation. Every 100 hours of operation, check the paper element and replace if necessary. Perform these maintenance procedures more often under extremely dusty or dirty conditions.

- a. **Precleaner Service:** Remove the air cleaner cover retaining knob, air cleaner cover, element cover nut, element cover and paper element with precleaner.

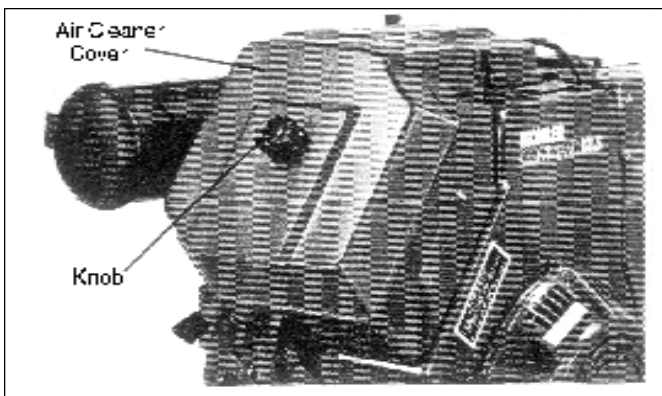

Figure 6 - Air Cleaner (external)

- b. Remove the precleaner from the paper element.
- c. Wash the precleaner in warm water with detergent. Rinse the precleaner thoroughly until all traces of detergent are eliminated. Squeeze out excess water (do not wring). Allow the precleaner to air dry.

- d. Saturate the precleaner with new engine oil. Squeeze out all excess oil.
- e. Reinstall the precleaner over the paper element.
- f. Reinstall the paper element with the precleaner, element cover, element cover nut, air cleaner cover, and air cleaner cover retaining knob.
- g. **Paper Element Service:** Remove the precleaner from the paper element.
- h. Do not wash the paper element or use pressurized air, as this will damage the element. Replace a dirty or damaged element. Handle the new element carefully and make sure that the sealing surface is not damaged before installing.
- i. When servicing the air cleaner, check all of the air cleaner components including the base and cover to be sure they fit securely. Replace any damaged or bent parts.
- j. Reinstall all components.

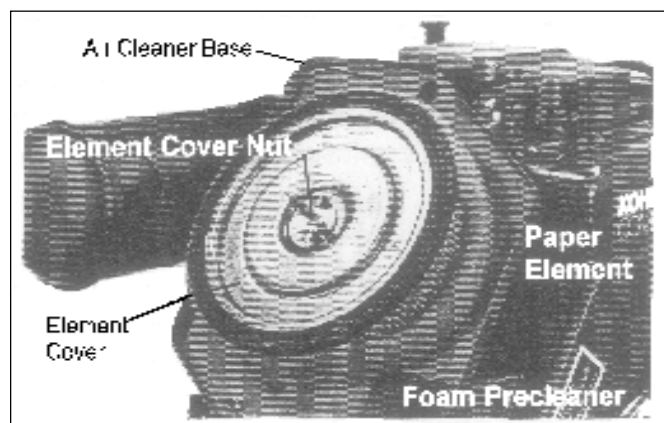

Figure 7 - Air Cleaner (internal)

---

---

# MAINTENANCE

---

---

## Air Intake System Check (Both Engine Options)

All of the cooling surfaces of the unit must be kept clean at all times to ensure proper cooling. Every 100 hours of operation ( more often under extremely dirty conditions), remove the blower housing and other cooling shrouds. Clean the cooling fins and external surfaces as necessary. Be sure to reinstall all shrouds and the housing.



**ATTENTION:** Operating with blocked screens, dirty cooling fins, and/or cooling shrouds removed, will cause engine damage due to overheating.

## Spark Plug Service (Figures 8 - Both engine options)

To ensure proper engine operation, the Spark Plug must be properly gapped and free of deposits.



**WARNING:** *The muffler becomes very hot during operation and remains hot for awhile after stopping the engine. Be careful not to touch the hot muffler when servicing the spark plug.*

- a. Remove the Spark Plug cover.
- b. Clean any dirt from around the Spark Plug base to keep dirt from entering the engine.
- c. Use the correct size spark plug wrench to remove the Spark Plug.
- d. Visually inspect the Spark Plug. Discard it if the insulator is cracked or chipped. Clean the Spark Plug with a wire brush if it is to be used again.
- e. Measure the plug gap with a feeler gauge. Correct as necessary by carefully bending the side electrode.  
Gap to:  
HONDA - 0.70-0.80 mm (0.028-0.031 in)  
KOHLER - 1.02 mm (0.040 in)

- f. Check that the Spark Plug washer is in good condition and thread the Spark Plug in by hand to prevent cross-threading.
- g. After the Spark Plug is seated, tighten with a spark plug wrench to compress the washer. The Spark Plug must be securely tightened. An improperly tightened Spark Plug can become very hot and may cause engine damage. When installing a new Spark Plug, tighten 1/2 turn after the spark plug seats. If reinstalling a used Spark Plug, tighten 1/4 turn after spark plug seats.

- h. Use only the recommended Spark Plug or equivalent.

Recommended Spark Plugs:

### HONDA

BPR6ES (NGK)

W20EPR-U (NIPPONDENSO)

### KOHLER

Champion® type RC12YC (or equivalent)

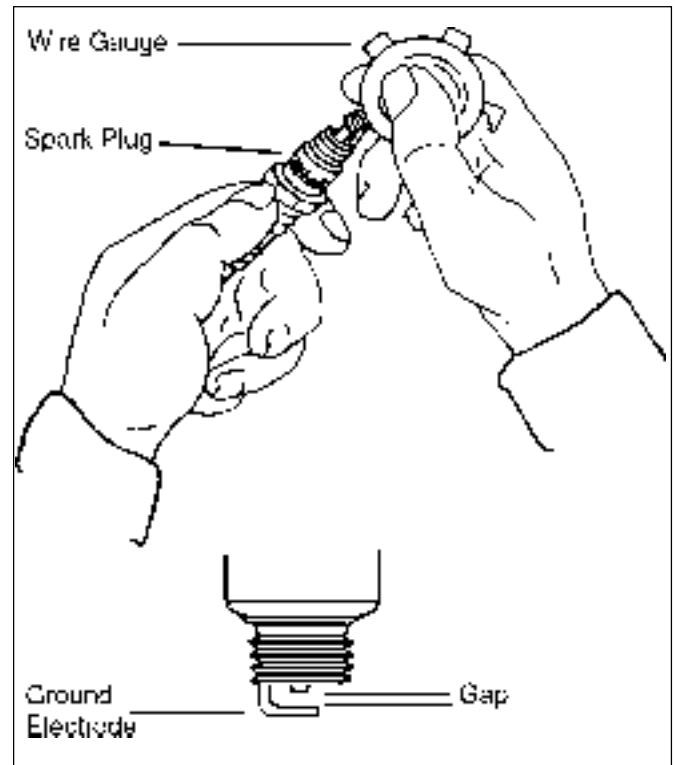

Figure 8 - Spark Plug Gap

---

---

# MAINTENANCE

---

---

## Sediment Cup Cleaning - HONDA (Figure 9)

A Sediment Cup is located on the carburetor under the Fuel Valve lever. It allows water and heavy contaminants to settle from the fuel before it can enter the carburetor. The Sediment Cup should be periodically checked and cleaned.

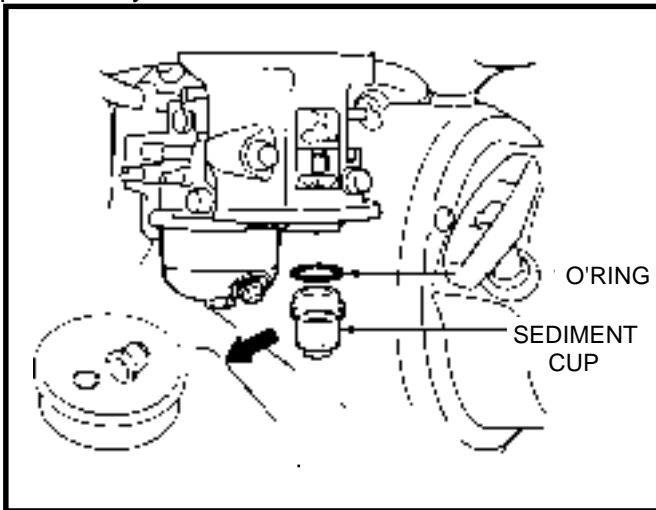

FIGURE 9 - Sediment Cup Cleaning



**WARNING:** Gasoline is extremely flammable and is explosive under certain conditions. Do not smoke or allow flames or sparks in the area.



**WARNING:** After installing the sediment cup, check for leaks and make sure that the area is dry before starting engine.

Turn the Fuel Valve to OFF. Remove the Sediment cup and O'Ring and wash them in nonflammable or high flash point solvent. Dry them thoroughly and reinstall securely. Turn the Fuel Valve ON and check for leaks.

## Carburetor Adjustment - HONDA (Figure 8)

- a. Start the engine and allow it to warm up to normal operating temperature.

- b. With the engine idling, turn the pilot screw in or out to the setting that produces the highest idle RPM. Usually the correct setting will be found to be 2-1/4 turns.
- c. After the pilot screw is correctly adjusted, turn the throttle stop screw to obtain the standard idle speed. (1400 + or - 150 RPM)

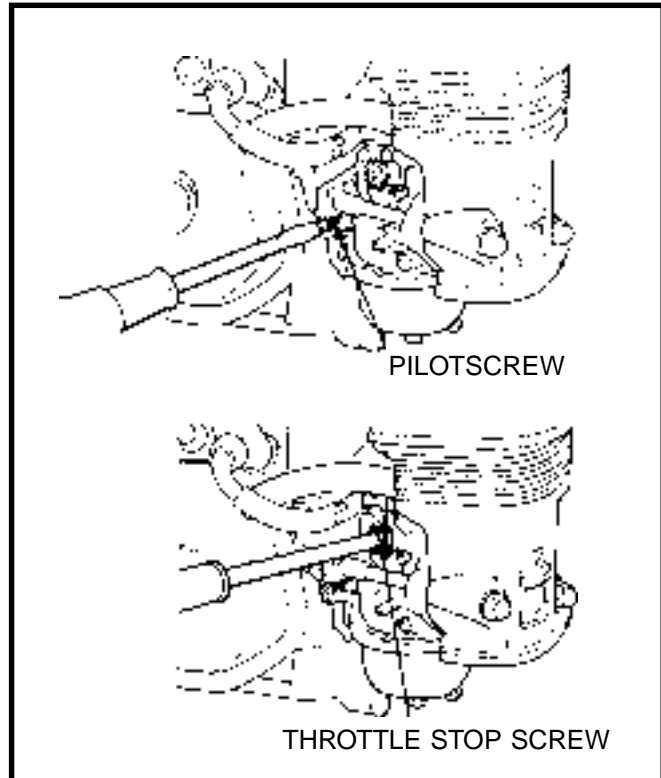

FIGURE 10 - Carburetor Adjustment (HONDA)

---

---

# MAINTENANCE

---

---

## Carburetor Adjustment (KOHLER)

- a. Start the engine and run at half throttle for 5 to 10 minutes to warm up. The engine must be warm before making the final settings.
- b. Place the throttle control into the "idle" or "slow" position. Set the low idle speed to 1200 RPM ( $\pm 75$  RPM) by turning the low idle speed adjusting screw "IN" or "OUT". Check the speed using a tachometer.
- c. Recheck the idle speed using a tachometer and readjust the speed as necessary.

## Battery (Both Engine Options)

The Battery for the Deluxe Rollpac III is located in the engine compartment of the roller. The seat and the top deck cover must be removed to remove or replace the Battery.

To remove the seat, remove the pin clip from the seat mounting rod, which is accessible by opening the hinged engine cover.



**WARNING:** *The battery gives off explosive gases; keep sparks, flames and cigarettes away to prevent fire or explosion. Provide adequate ventilation when charging or using batteries in an enclosed space. Remove all jewelry when servicing batteries.*



**WARNING:** *The battery contains sulfuric acid (electrolyte). Contact with the skin or eyes may cause severe burns. Wear protective clothing and a face shield. If electrolyte gets on your skin, flush with water. If electrolyte gets in your eyes, flush with water for at least 15 minutes and call a physician immediately.*

*If electrolyte is swallowed, drink large quantities of water or milk and follow with milk of magnesia or vegetable oil and call a physician. KEEP ALL BATTERIES OUT OF REACH OF CHILDREN!*

- a. Starting an engine depends on good cranking speed. It is important that the Battery always be fully charged and that all the cables and terminals are cleaned and properly connected to the Battery.
- b. Check the level of Battery electrolyte regularly. Add distilled water if necessary, but do not overfill. Overfilling can cause poor performance or early failure. A "maintenance free" type battery should rarely require additional electrolyte.

(cont.)

---

---

# MAINTENANCE

---

---

## Battery (Both Engine Options)

- c. Keep the top of the Battery clean. When necessary, wash with a baking soda solution (1 part baking soda to 4 parts water) and rinse with fresh water. Do not allow the soda solution to enter the battery cells.
- d. Inspect the cables, clamps and hold down bracket regularly. Clean and apply a light coating of grease when needed. Replace corroded or damaged parts if necessary.



**WARNING:** *Be sure all switches are "OFF" before disconnecting the negative (-) ground cable. Switches that are "ON" will cause a spark at the ground cable terminal which could cause an explosion if gasses from the battery or fuel are present. Always disconnect battery ground (-) cable first and always reconnect the positive (+) battery cable first when servicing battery cables and when removing or replacing the battery. It is recommended to also remove the Ground (-) cable when welding on the machine.*

- e. Check the electrical charging system if the Battery becomes discharged repeatedly. If the engine is difficult to start or the Battery seems weak, clean and check the terminal connections. If the problem continues, the Battery should be tested using a battery tester for voltage and current draw.
- f. If the roller is to be stored for more than thirty (30) days, remove the Battery from the Deluxe Rollpac III and store in a cool, dry place. During storage, keep the Battery fully charged and check the level of the electrolyte regularly.

---

---

# MAINTENANCE

---

---

## DRIVE SYSTEM MAINTENANCE

### General

The Deluxe Rollpac III Hydrostatic Drive System consists of a Sunstrand 15 Series variable displacement axial piston pump connected in a closed circuit to a Charlynn 2000 Series fixed displacement motor which drives the rear drum through chain and sprockets.

Control of the Hydrostatic Drive System is provided through a linear mechanical control lever which includes a neutral switch.

This manual contains general system maintenance guidelines, however, more detailed service and maintenance information is available directly from the hydraulic component manufacturers.

### Hydraulic System (Figure 11)

Refer to the Hydraulic Fluids chart when adding or changing oil. The use of hydraulic oil that is not equal to those listed could result in substandard performance or even possible failure of the roller's hydraulic components.

If you are not sure whether a specific hydraulic oil is suitable for use in the Deluxe Rollpac III, contact your authorized ROSCO Dealer.

- a. Remove and replace hydraulic oil and filter after first 100 hours of service and then every 500 hours thereafter (or seasonally). Use genuine ROSCO replacement parts when changing the filter element.

To Replace Oil and Filter:

- b. Remove oil from the reservoir by using a suction device. You will have to remove the complete Filler Cap/Strainer Assembly. Use caution when removing the Hydraulic Reservoir filler cap/strainer assembly to prevent any foreign matter from entering the Hydraulic Reservoir. Clean off the top of the reservoir and remove the screws attaching the

Filler cap/Strainer Assembly to the top of the reservoir. Carefully remove the cap and strainer from the reservoir taking care that the gaskets are also removed.



**Attention:** Always clean the top of the reservoir before opening the filler cap. Foreign matter may enter the reservoir and contaminate the oil. Contaminated oil will cause pump and motor wear and/or failure.

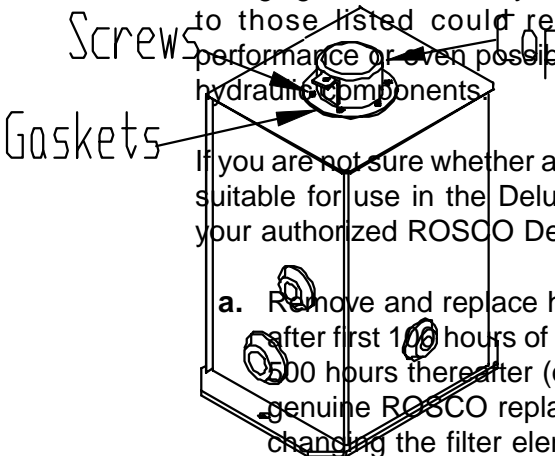

FIGURE 11 - Hydraulic Reservoir

- c. Replace Filler Cap/Strainer Assembly, making sure that there is one gasket between the tank and the strainer lip and one gasket between the strainer lip and the cap.
- d. Carefully remove the Hydraulic Fluid Filter element and replace with proper element (see preventive maintenance chart at the end of this section).
- e. Fill hydraulic reservoir with fresh fluid. Make certain that the level of hydraulic oil is kept 1/2 to 1 inch below the top surface of the reservoir in order to allow for expansion.

(cont.)

---

---

# MAINTENANCE

---

---

## Hydraulic System (cont.)

- f. After changing the filter, idle the engine for 3 minutes with the Control Lever in neutral and with the Park/Emergency Brake engaged. At the end of this idling period disengage the Park/Emergency Brake and **SLOWLY** move the Control Lever forward and reverse. This procedure will remove all air induced into the system by the removal of the filter. Failure to follow this prescribed procedure may cause partial or complete failure of the hydraulic pump.
  
- g. Inspect the Deluxe Rollpac III before each use for the possibility of hydraulic leaks. Also, the operator should occasionally have another person standing along side the roller during operation to watch for hydraulic leaks which may only be noticeable when the unit is running. It is very important to repair any leaks as soon as possible to prevent damage to the system.



**WARNING:** *Never use the hand to locate hydraulic leaks. Hydraulic fluid under pressure will pierce the skin. Serious infections or toxic reaction can develop from hydraulic fluid penetrating the skin surface. If hydraulic oil has pierced the skin get immediate medical attention.*



**WARNING:** *Always wear eye protection when inspecting for leaks in the hydraulic system.*

---

---

# MAINTENANCE

---

---

## Transmission Control Lever (Figure 9)

A Neutral Switch, located on the Transmission Control Lever, will prevent the engine starting when the hydraulic pump is not in the neutral position.

If, at any time, it is noticed that the roller attempts to move while starting the engine (with the Park/Emergency Brake disengaged and the Control Lever in neutral), the Control Lever ball joint must be adjusted. (Figure 12)

- a. Remove the seat and top deck cover to access the Control Lever mechanism.
- b. Position the Carriage Bolt (Item 1) so that the bolt head rests snugly in the beveled hole on the Control Lever Mount (Item 2) and tighten. Tighten nuts on Rod Ends (Items 3 & 4) and torque Dog Point Set Screws (Item 5) to 20 #.

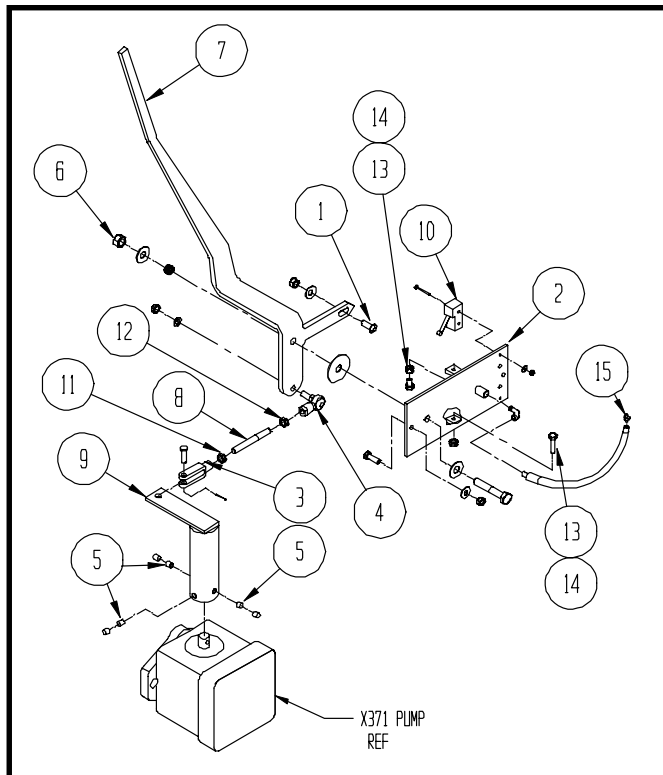

FIGURE 12 - Transmission Control Lever Adjustment

- c. Use the Locknut (Item 6) to regulate pressure on the Control Lever (Item 7). There should be enough tension on the lever to keep it in the neutral position but not too tight to keep it from working smoothly.
- d. Use the Pump Control Rod (Item 8) to adjust positioning of the lever by turning the rod.
- e. When properly positioned, the following conditions will apply:
  - (1) The Pump Tube (Item 9) will be positioned within  $\pm .010$  of pump zero displacement;
  - (2) The roller on the arm of the Neutral Switch (Item 10) will be fully retracted and resting on the pointed end of the Control Lever;
  - (3) The Carriage Bolt (Item 1) will be perfectly centered in the beveled hole.
- f. When the correct position is found, tighten Jam Nuts (Items 11 & 12) to lock in place. Any further adjustment may be made by loosening nuts and rotating the Pump Control Rod.
- g. Bolts (Item 13) and Jam Nuts (Item 14) should be adjusted to stop the lever travel just before the pump is fully stroked.
- h. Grease Carriage Bolt (Item 1) with Lube Fitting (Item 15) after assembly so it does not drag when shifting.

---

---

# MAINTENANCE

---

---

## Drive Chain Adjustment (Figure 13)

The final drive for the Deluxe Rollpac III is provided by a Hydraulic Motor through a chain and sprockets connected to the Rear Drum.

The chain must be properly adjusted and well lubricated in order to obtain good performance and component life.



**WARNING:** Do not attempt drive chain adjustment with engine running. Place all controls in neutral, stop engine, remove ignition key and wait for all moving parts to stop before servicing, adjusting or repairing. Failure to do so, may result in serious injury.

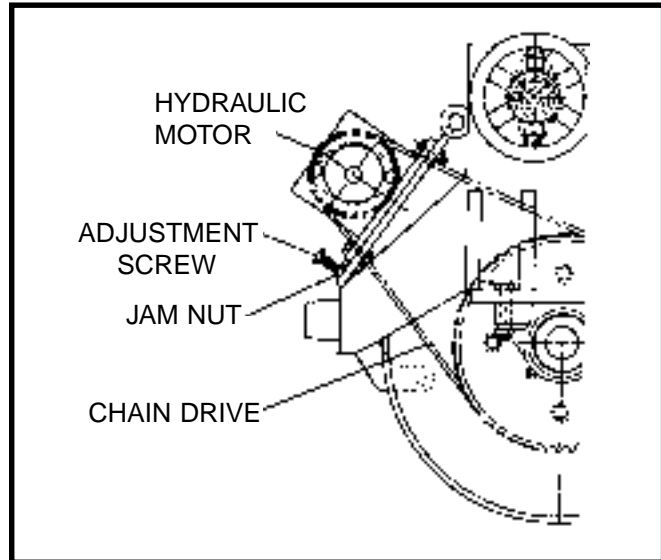

FIGURE 13 - Drive Chain

- a. If excessive slack is noticed in the chain during daily inspection, the chain can be tightened with the two adjustment screws located between the Hydraulic Motor mount plate and the roller frame. (It may be necessary to remove the seat and top deck cover to gain access to the adjustment screws.)
- b. To adjust the Drive Chain tension loosen the jam nuts on both adjustment screws.
- c. Tighten the adjustment screws **EVENLY** until no more than 1/4 to 3/8 inch of total up/down deflection exists when finger pressure is applied to the chain midway between the Hydraulic Motor and the Rear Drum.
- d. Temporarily replace driver's seat and while sitting in the seat, start the engine and slowly move the Transmission Control Lever to reverse so that the roller moves a few inches.
- e. Return the Control Lever to neutral, shut off the engine and recheck the up/down deflection in the chain.

(*ALTERNATE METHOD:* The roller can be placed on jack stands so that the Rear Drum is completely off the ground. In this way, the chain tension can be observed as the drum is rotated without having to ride the roller.)

- f. If the chain is either too tight or too loose, make an adjustment as required. Then repeat the procedure in steps **d.** & **e.** (or the alternative method).
- g. After adjustment is complete and satisfactory, be sure that both adjusting screws have been turned the same amount and are locked in place with the jam nuts. The chain may vary from tight to loose as the drum rotates. A slight variation in tension is normal. However, if the variation is excessive, the rear sprocket may need to be re-centered on the drum.

---

---

# MAINTENANCE

---

---

## Re-Centering Sprocket on the Drum

### **ON THE ROLLER:**

- a. Rotate the drum to a position where the chain seems to be the tightest.
- b. Mark the drum (or sprocket) and a stationary reference point on the roller frame.
- c. Rotate drum to a position where the chain is the most loose.
- d. Mark the drum (or sprocket) again. The two marks should be 180° apart. If not, repeat steps **a.** through **d.** (in both forward and reverse) until you are satisfied you have located the two extremes in chain tension.
- e. Position drum in the tightest chain position and slightly loosen the 4 bolts holding the sprocket to the drum.
- f. With a prybar or rubber hammer, move the large sprocket slightly towards the motor sprocket.



**ATTENTION:** A small displacement of 1/16 inch (1.59 mm) makes a major difference in chain tension.

- g. Tighten sprocket attaching bolts and test per steps **a.** through **d.** Repeat steps **e.** through **g.** as required.

### **OFF THE ROLLER:**

- a. Remove the Rear Drum and set it on end with the sprocket end up and the axle shaft in place.
- b. Loosen bolts holding the sprocket to the drum.
- c. Use a large outside calipers and accurately measure the distance from the outside diameter of the sprocket to the opposite side of the shaft in several locations.
- d. Tap the sprocket lightly using a rubber faced hammer to center the sprocket.

- e. Tighten the bolts and recheck to make sure the sprocket is still centered. Repeat steps **a.** through **e.** if needed.
- f. Replace the drum on the roller and check chain tension with the drum rotating.

---

---

# MAINTENANCE

---

---

## CHASSIS MAINTENANCE

### Greasing and Oiling

- a. Grease fittings are provided on the chassis as follows:
  - ⇒ The Bearings at each end of the Front Drum assembly;
  - ⇒ Steering Pivot, two locations;
  - ⇒ Bearings at each end of the Rear Drum assembly.Use chassis lubricant and grease each location daily.
- b. Apply a light oil, such as SAE 10 weight motor oil by brush or oil can to the Drive Chain weekly and after 100 hours operation.
- c. The Steering Gear box should not require servicing of lubricant unless it is dismantled to replace or repair parts. An EP chassis lube should be used (11 oz) when reassembling the gear box.

### Park/Emergency Brake (Figure 14)

Visually inspect the condition of the Park/Emergency Brake every 100 Hours of service.

To check the operation of the brake:

- a. Start the engine and set the RPM at 1/4 throttle.
- b. Engage the Park/Emergency Brake.
- c. Slowly and very slightly, move the Transmission Control Lever forward.
- d. If the engine begins to lug down and the roller doesn't move, the Park/Emergency Brake is properly adjusted. DO NOT move the Control Lever beyond this slightly engaged position.

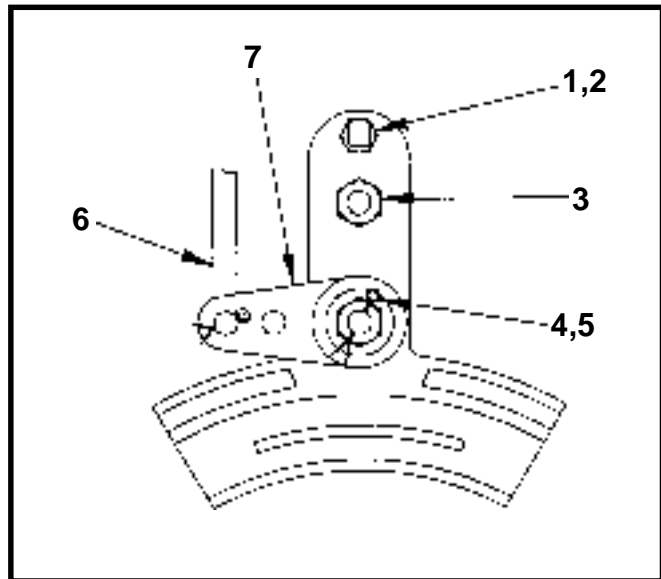

FIGURE 14 - Park/Emergency Brake Adjustment

- e. If the roller begins to move forward without the engine lugging, adjustment of the Park/Emergency Brake is required. It may be necessary to remove the seat and top deck cover to adjust the brake.

### Park/Emergency Brake Adjustment

Proper brake adjustment involves adjusting the brakes so that the pads are parallel and engage the brake disc evenly when applied. (Figure 13)

- a. Adjust the Brake Linkage (Item 6), if needed, so that the Cam (Item 7) is roughly centered on the pins.
- b. Loosen the Locknut (Item 1) and back out the Set Screw (Item 2) about 2 to 3 turns.
- c. Remove the Cotter Pin (Item 4) and turn Nut (Item 5) tighter until the brake pads have firmly closed on the disc.
- d. Adjust the Set Screw (Item 2) until the brake halves are parallel with each other and then tighten Locknut (Item 1).

(cont.)

---

---

# MAINTENANCE

---

---

## Park/Emergency Brake Adjustment (cont.)

- e. Tighten Item 3 until it bottoms on the brake half, then loosen about 1/2 turn.
- f. Loosen Item 5 two turns and replace Cotter Pin.
- g. Test the brake actuation force by engaging Brake Lever. A force of 20 pounds on the end of the lever should be all that is required to engage the brake.

**NOTE:** If more than 20 pounds is required to engage the brake, loosen Item 5 about 1/6 turn at a time until the proper force is obtained.

## STORAGE

A stored machine requires as much periodic maintenance as a machine at work. Units not in use must receive periodic scheduled maintenance. Many instances of customer downtime and dissatisfaction can be traced to parts that became defective due to inattention to stored machines.

Often equipment is stored where it is subjected to damage, dirt and weather. Below are procedures, which if followed, will help maintain equipment and lessen downtime.

- a. All units should be stored where they are protected from adverse weather conditions. Likewise, all replacement parts, whether complete assemblies, component repair parts, service kits, etc., should be stored in a dry sheltered area.
- b. The following preventative maintenance procedures should be followed on any units which will not be used for more than two (2) months.
  - 1. Check for Water in Hydraulic Fluid. Any machine that is stored for an extended period in a climate that has a wide range of temperatures and /or humidity, should have the hydraulic fluid checked on a regular basis for possible contamination. This moisture is generally produced by condensation on the inside of the tank walls. Hydraulic oil that is contaminated must be drained, the filter elements replaced and the tank refilled with Rosco approved fluid. Failure to do this could result in premature failure of the pumps and /or motors.
  - 2. Warm-up and Cycling. Start and the engine until warm. Cycle all hydraulic and/or hydrostatic functions until all components are warm and the hydraulic fluid is up to operating temperature.

(cont.)

---

---

# MAINTENANCE

---

---

## STORAGE (cont.)

3. Lubrication. After the machine is warmed-up, grease all pivot points, following standard Operation Manual procedures.

The following procedures are specific for the unit you have. After performing the Warm-up and Cycling procedure above, you will have to repeat the following procedures to protect the engine and ensure the unit will be ready for service during the next working season.

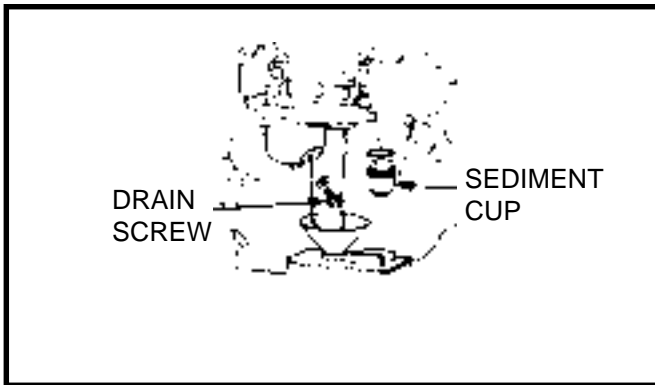

FIGURE 15 - Draining Fuel Tank

### Drain Engine Fuel Tank (Figure 15) (HONDA shown)

- a. With the Fuel Valve OFF remove and empty the Sediment Cup.  
  
*Note: Referances to the Sediment Cup refer to HONDA engines only.*
- b. Turn Fuel Valve ON and drain the gasoline in the fuel tank into a suitable container.
- c. Replace Sediment Cup and tighten securely.
- d. Drain the carburetor by loosening the drain screw. Drain the gasoline into a suitable container.



**WARNING:** Gasoline is extremely flammable. Its vapors can cause explosion if ignited. Store gasoline only in approved containers, in unoccupied buildings, away from sparks and flames. Do not add gasoline to the fuel tank while the engine is hot or running. Do not start the engine around spilled fuel. Never use gasoline as a cleaning agent.



**WARNING:** Do not Smoke while fueling the unit or if gasoline vapors may be present! An explosion can occur.

### Change the Oil

- a. See "Changing Oil in this Section.

### Remove Spark Plug

- a. Pour about a tablespoon of clean engine oil into the cylinder.
- b. Crank the engine several times to distribute the oil, then reinstall the spark plug.

### Clean Exterior Surfaces of Engine

- a. Spread a light film of oil over any nonpainted metal surface of the engine to prevent rust.

### General Machine

- a. Be sure the Water Tank and Spraybar lines are drained. This is accomplished by opening the Spraybar valves and allowing them to completely drain.
- b. If water ballast was used in the front and/or rear drums, they should also be drained if you do not use a water/antifreeze mix. Be sure to drain both front drums and the rear drum.



**ATTENTION:** Freezing water will ruin drums and the front yoke.

(Cont.)

---

---

# MAINTENANCE

---

---

## STORAGE (cont.)

- c. Grease all moving parts and lubrication points at this time. Also, apply good lubricant to the drive chain.
- d. This would be an excellent time to completely clean the roller and make a general inspection of all moving parts and components which may require repair or maintenance. Any items in need of replacement or repair can be taken care of at this time to assure that the Deluxe Rollpac III is in top shape for the next operating season.
- e. Store the machine in an area away from human activity.
- f. Do not permit children to play on or around the stored machine!
- g. Make sure the unit is stored in an area that is firm, level and free of debris.
- h. Store the machine inside a building or cover securely with a weatherproof tarpaulin.
- i. Be sure to follow the start-up procedure found in Section II when you are putting the Deluxe Rollpac III back into operation.

# HYDRAULIC FLUIDS

The below recommended hydraulic oils have been reviewed by Rosco and are recommended as replacement fluids. It is best to use the heaviest weight oil that can be safely used for the temperature range in which the machine will be operating. If your machine will not be used at below 0° F (-18° C) temperatures, we recommend that you use a heavier weight oil.

If you are considering using an oil that is not listed on the chart below, contact the Rosco factory to obtain the specifications that the hydraulic oil must meet to provide the needed lubrication and cooling for the units' hydraulic components.

## HYDRAULIC OIL REQUIREMENTS AND APPROVED BRANDS FOR FIELD FILL:



*DO NOT MIX manufacturers or grade weights when adding hydraulic oil.*

- Be sure** hydraulic oil selection is compatible with your hydraulic system.
- Be sure** to use mineral base hydraulic oil.
- Be sure** hydraulic oil selection assistance is from a reputable supplier.
- Be sure** the hydraulic specifications meet or exceed the following specifications.

Hydraulic oil viscosity must not fall below 70 SUS (13 cs) in the reservoir under the most adverse conditions. The best viscosity being 80-300 SUS (17 cs to 65 cs). The viscosity rating at the lowest expected start-up temperature should not exceed 10,000 SUS (2158 cs).

Hydraulic oil must have rust and oxidation inhibitors that will maintain chemical stability. When changing the hydraulic oil with oil other than the specific factory fill oil listed below, the hydraulic system must be completely drained. Be sure to purge or drain all hoses, cylinders, valves, motors and pumps of hydraulic oil. All hydraulic oil filters must also be changed at this time.

Hydraulic oil must provide anti-wear properties that meet or exceed those found in the API (American Petroleum Institute) classification SD, SE or CC crank case oil.

AMBIENT TEMP. -25° TO 80° F (-32° TO 27° C)	AMBIENT TEMP. -10° TO 95° F (-23° TO 35° C)	AMBIENT TEMP. 0° TO 105° F (-18° TO 41° C)
Amoco Rykon 32	Amoco Rykon 46	Amoco Rykon 68
Exxon Unavis N32	Exxon Unavis N46	Exxon Unavis N68
Gulf Harmony 32 AW	Gulf Harmony 46 AW	Gulf Harmony 68 AW
Mobil DTE 13M	Mobil DTE 15M	Mobil DTE 16M
Phillips 66 Magnus A32	Phillips 66 Magnus A46	Phillips 66 Magnus A68
Shell Tellus 32	Shell Tellus 46	Shell Tellus 68
Texaco 32	Texaco 48	Texaco 68
Chevron MV ISO 32	Mobilfluid No. 424	Conoco 68

# HYDRAULIC FITTING TORQUE

## Tightening Flare Type Tube Fittings

1. Check the flare and flare seat for defects that might cause leakage.
2. Align tube with fitting before tightening.
3. Lubricate connection and hand tighten swivel nut until snug.
4. To prevent twisting the tube(s), use two wrenches. Place one wrench on the connector body and with the second tighten the swivel nut to the torque shown.

Note: The torque values shown are based on lubricated connections as in assembly.

Tube Size OD	Nut Size Across Flats	Torque Value (see note)		Recommended Turns to Tighten (After Finger Tightening)	
		(N.m)	(lb-ft)	(Flats)	(Turns)
(in)	(in)				
3/16	7/16	8	6	1	1/6
1/4	9/16	12	9	1	1/6
5/16	5/8	16	12	1	1/6
3/8	11/16	24	18	1	1/6
1/2	7/8	46	34	1	1/6
5/8	1	62	46	1	1/6
3/4	1-1/4	102	75	3/4	1/8
7/8	1-3/8	122	90	3/4	1/8

## TIGHTENING O-RING FITTINGS

1. Inspect O-ring and seat for dirt or obvious defects.
2. On angle fittings, back the lock nut off until washer bottoms out at top of groove.
3. Hand tighten fitting until back-up washer or washer face (if straight fitting) bottoms on face and O-ring is seated.
4. Position angle fittings by unscrewing no more than one turn.
5. Tighten straight fittings to torque shown.
6. Tighten while holding body of fitting with a wrench.

Note: The torque values shown are based on lubricated connections as in reassembly.

Tube Size OD	Nut Size Across Flats	Torque Value (see note)		Recommended Turns to Tighten (After Finger Tightening)	
		(N.m)	(lb-ft)	(Flats)	(Turns)
(in)	(in)				
3/8	1/2	8	6	2	1/3
7/16	9/16	12	9	2	1/3
1/2	5/8	16	12	2	1/3
9/16	11/16	24	18	2	1/3
3/4	7/8	46	34	2	1/3
7/8	1	62	46	1-1/2	1/4
1-1/16	1-1/4	102	75	1	1/6
1-3/16	1-3/8	122	90	1	1/6
1-5/16	1-1/2	142	105	3/4	1/8
1-5/8	1-7/8	190	140	3/4	1/8
1-7/8	2-1/8	217	160	1/2	1/12

# BOLT TORQUE CHART

The table below gives the correct torque values for various **NON-LUBRICATED** bolts. **DO NOT** lubricate bolts unless otherwise specified in this manual. Check tightness of bolts periodically, using this table as a guide. **ALWAYS** replace hardware with an equal strength fastener. When using locking fasteners, increase torque values by 5%.

## BOLT IDENTIFICATION BY HEAD MARKINGS:

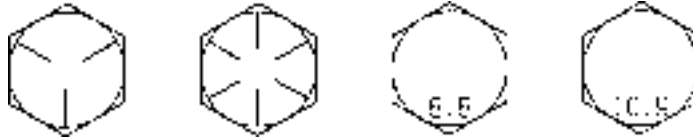

BOLT SIZE	ENGLISH				METRIC			
	GRADE 5		GRADE 8		CLASS 8.8		CLASS 10.9	
	FT-LB	N-M	FT-LB	N-M	FT-LB	N-M	FT-LB	N-M
M6					7	10	11	15
1/4	9	12	12	17				
5/16	19	25	27	36				
M8					18	25	26	35
3/8	33	45	45	63				
M10					37	50	52	70
7/16	53	72	75	100				
M12					66	90	92	125
1/2	80	110	115	155				
M14					103	140	148	200
9/16	115	155	165	220				
5/8	160	215	220	305				
M16					166	225	229	310
3/4	290	390	400	540				
M20					321	435	450	610
7/8	420	570	650	880				
M24					553	750	774	1050
1	630	850	970	1320				
M30					1103	1495	1550	2100

N-M = newton meter      Ft-Lb = foot pound

# TROUBLE SHOOTING

The following Trouble Shooting information includes some problems (and possible solutions) that an operator may encounter during the course of operating the Deluxe Rollpac III. For specific engine problems not encompassed in this manual refer to the Engine Manufacturer's Manual.

When a problem occurs do not overlook the simple causes. A starting problem could be caused by something as simple as an empty fuel tank. After a mechanical failure has been corrected, be sure to locate and correct the cause of the problem so the same failure will not be repeated.



**ATTENTION:** Do not attempt to repair major components such as the gasoline engine or the hydrostatic pump and motor unless authorized to do so by your ROSCO Dealer. Any unauthorized repair will void the warranty.

POSSIBLE TROUBLE	CAUSE	REMEDY
<p>Engine does not start or hard starting.</p>	<ol style="list-style-type: none"> <li>1. No fuel.</li> <li>2. Control Lever not in neutral position.</li> <li>3. Neutral switch not activated.</li> <li>4. Pump not in neutral.</li> <li>5. Dirty engine air filter or faulty spark plug.</li> <li>6. Plugged fuel filter or water in fuel.</li> <li>7. Weak Battery.</li> <li>8. Poor electrical connections.</li> <li>9. Faulty starter or solenoid.</li> </ol>	<ol style="list-style-type: none"> <li>1. Fill fuel tank.</li> <li>2. Move Control Lever to neutral position.</li> <li>3. Adjust linkage.</li> <li>4. Adjust linkage.</li> <li>5. Clean or replace.</li> <li>6. Replace filter and /or fuel.</li> <li>7. Charge or replace.</li> <li>8. Check and tighten.</li> <li>9. Repair or replace.</li> </ol>
<p>Roller moves in one direction only, or neither direction.</p>	<ol style="list-style-type: none"> <li>1. Control lever-loose hardware.</li> <li>2. Control linkage stripped or broken.</li> <li>3. Low hydraulic oil.</li> <li>4. Leaky fitting or broken hose.</li> <li>5. Faulty charge valves on pump.</li> <li>6. Pump or motor</li> </ol>	<ol style="list-style-type: none"> <li>1. Check tightness of all linkage bolts.</li> <li>2. Repair or replace.</li> <li>3. Refill with proper fluid.</li> <li>4. Tighten or replace.</li> <li>5. Repair or replace.</li> <li>6. Check charge pressure.</li> </ol>

<b>POSSIBLE TROUBLE</b>	<b>CAUSE</b>	<b>REMEDY</b>
Low charge pressure in hydrostatic pump.	<ol style="list-style-type: none"> <li>1. Filter plugged.</li> <li>2. Charge relief valve faulty.</li> <li>3. Implement relief valve faulty.</li> <li>4. Charge pump faulty.</li> </ol>	<ol style="list-style-type: none"> <li>1. Replace.</li> <li>2. Replace.</li> <li>3. Replace.</li> <li>4. Replace.</li> </ol>
Roller jerks when starting to move.	<ol style="list-style-type: none"> <li>1. Improper fuel or dirt in fuel line.</li> <li>2. Hydraulic oil too heavy.</li> <li>3. Hydraulic oil supply low.</li> <li>4. Filter plugged or air in system.</li> <li>5. Leaky fitting or hose.</li> <li>6. Pump</li> </ol>	<ol style="list-style-type: none"> <li>1. Clean fuel line and drain.</li> <li>2. Change with viscosity oil.</li> <li>3. Fill tank to proper level.</li> <li>4. Clean or replace filter</li> <li>5. Tighten or replace.</li> <li>6. Check charge pressure.</li> </ol>
Engine or hydraulic system Overheats.	<ol style="list-style-type: none"> <li>1. Dirty engine air intake screen or air filter element.</li> <li>2. Hydraulic cooler dirty.</li> <li>3. Low oil level in engine or hydraulic tank.</li> <li>4. Oil too light in engine.</li> <li>5. Excessive internal leakage in pump.</li> <li>6. Low system pressure.</li> </ol>	<ol style="list-style-type: none"> <li>1. Clean.</li> <li>2. Clean.</li> <li>3. Fill to proper level with proper fluid.</li> <li>4. Drain and refill with proper viscosity oil.</li> <li>5. Check charge pressure.</li> <li>6. Replace charge check valves.</li> </ol>
Engine runs rough.	<ol style="list-style-type: none"> <li>1. Improper fuel.</li> <li>2. Water or impurities in fuel line.</li> <li>3. Spark plug lead loose.</li> <li>4. Carburetor improperly adjusted.</li> <li>5. Incorrect valve to tappet clearance.</li> <li>6. Faulty ignition module.</li> <li>7. Poor electrical connections.</li> </ol>	<ol style="list-style-type: none"> <li>1. Replace fuel.</li> <li>2. Replace fuel and filter.</li> <li>3. Repair or replace.</li> <li>4. Adjust carburetor.</li> <li>5. Adjust clearance.</li> <li>6. Replace module.</li> <li>7. Check and tighten as needed.</li> </ol>
Engine backfires when machine is shut off.	<ol style="list-style-type: none"> <li>1. Engine is shut off without allowing sufficient cooling time.</li> </ol>	<ol style="list-style-type: none"> <li>1. Allow machine to idle for 15 seconds before turning off the key.</li> </ol>

# PREVENTIVE MAINTENANCE CHART - HONDA

I = INSPECT  
A = ADJUST  
R = REPLACE

C = CHECK LEVEL/CLEAN  
S = SERVICE  
L = LUBRICATE

Item	Daily	1st time or 20 hrs.	Monthly or 50 hrs.	6 mo. or 100 hrs.	Yearly or 300 hrs.	500 hrs.	Capacity	Part No.	Type
Engine Oil	C	R		R	R		1.6 U.S. Qts. (1.10 L)	See oil recommendations in this manual	
Air Intake & Cooling	I	C/I							
Fuel	C						1.72 gal. (6.51 L)		
Fuel Filter				C/R	R			37278-08	
Air Cleaner	C		S					37278-04	
Spark Plug				I/A/R	R				
Hydraulic Filter & Fluid	C					R R	Filter 2 gal (7.57 L)	X260	Spin on Refer to chart
Hydraulic Cooler	I/C								Flow Thru
Drive Chain	I			L					Chain Lube
Emergency Brake	I			I/A					
Front & Rear Drum Bearings	I/L			L					Multi - Service Grease
Transmission Control Lever	L								Multi - Service Grease
King Pins				L					Multi - Service Grease
Steer Box Fluid				C		I			Gear Lube 80W - 90
Steering Rod Ends				I					
Axle Bearings						I/L			Multi - Service Grease
Battery & Cables						I/C			
Valve Clearance Fuel Tank & Strainer					S S		Have a Honda Engine Service Dealer perform this service.		

# PREVENTIVE MAINTENANCE CHART - KOHLER

I = INSPECT  
A = ADJUST  
R = REPLACE

C = CHECK LEVEL/CLEAN  
S = SERVICE  
L = LUBRICATE

Item	Daily	1st time or 5 hrs.	Monthly or 25 hrs.	6 mo. or 100 hrs.	200 hrs.	Yearly or 500 hrs.	Capacity	Part No.	Type
Engine Oil	C	R		R			4 U.S. Pints (1.9 L)	See oil recommendations in this manual	
Engine Oil Filter					R			35234	
Air Intake & Cooling	I			C/I					
Fuel	C						5 Quarts (4.73 L)		
Fuel Filter	C			C/R	R			72750-01	
Air Cleaner Precleaner			C/R					72750-02	
Air Cleaner Paper Element				I/R				35233	
Spark Plug					I/A/R				
Hydraulic Filter & Fluid	C					R R	Filter 2 gal (7.57 L)	X260	Spin on Refer to chart
Hydraulic Cooler	I/C								Flow Thru
Drive Chain	I			L					Chain Lube
Emergency Brake	I			I/A					
Front & Rear Drum Bearings	I/L			L					Multi - Service Grease
Transmission Control Lever	L								Multi - Service Grease
King Pins				L					Multi - Service Grease
Steer Box Fluid				C		I			Gear Lube 80W - 90
Steering Rod Ends				I					
Axle Bearings						I/L			Multi - Service Grease
Battery & Cables						I/C			
Starter Solenoid						S I/C	Have a Kohler Engine Service Dealer perform this service.		

# SECTION IV

## DELUXE ROLLPAC III - PARTS BOOK

### A. GROUP 1 - HONDA ENGINE ASSEMBLY

- 1. MAIN ASSEMBLY ..... 4.2 - 4.7
- 2. HORN GROUP ..... 4.6
- 3. ENGINE ASSEMBLY, 13 HP ..... 4.8 - 4.9
- 4. ENGINE WIRING HARNESS ..... 4.10 - 4.11
- 5. FINAL ASSEMBLY- DECALS & MISCELLANEOUS ..... 4.12 - 4.15

### B. GROUP 2 - BASE UNIT ASSEMBLY

- 1. REAR SCRAPER & COCO MAT ..... 4.16 - 4.17
- 2. FRONT DRUM/YOKE ASSEMBLY ..... 4.18 - 4.19
- 3. FRONT SCRAPER & COCO MAT ..... 4.20 - 4.21
- 4. TRANSMISSION CONTROL LEVER ..... 4.22 - 4.23
- 5. STEERING GEAR (EXPLODED VIEW) ..... 4.24 - 4.25

### C. GROUP 1 - KOHLER ENGINE ASSEMBLY

- 1. MAIN ASSEMBLY ..... 4.26 - 4.28
- 2. HORN GROUP ..... 4.28
- 3. ENGINE ASSEMBLY, 15 HP ..... 4.29 - 4.30
- 4. ENGINE WIRING HARNESS ..... 4.30 - 4.31
- 5. FINAL ASSEMBLY- DECALS & MISCELLANEOUS ..... 4.32

### D. GROUP 4 - SERVICE KITS AND OPTIONS

- 1. DECAL KIT, HONDA ONLY - (NO ILLUSTRATION) ..... 4.33
- 2. SERVICE KIT, HONDA ONLY - (NO ILLUSTRATION) ..... 4.33
- 3. TRAILER, DELUXE W/O BRAKES - (NO ILLUSTRATION) ..... 4.34
- 4. SMV GROUP - (NO ILLUSTRATION) ..... 4.34
- 5. BACKUP ALARM - (NO ILLUSTRATION) ..... 4.34
- 6. SHORT BATTERY GROUP - OPTION ..... 4.34
- 7. BYPASS VALVE WRENCH- OPTION ..... 4.35
- 8. COCO MAT CHAIN UP - OPTION ..... 4.35



**GROUP 1**

ITEM	PART NUMBER	QTY	DESCRIPTION
	<b>54916</b>	<b>Rev. J1</b>	<b>MAIN ASSEMBLY, HONDA</b>
4	35228	1.00	CABLE,BATTERY,POS,4GAX14
5	51855	1.00	PITMAN ARM,REWORKED
7	52901	1.00	TAB W/M,FRONT FACE
11	54596	1.00	COCO MAT GROUP,DELUXE (See Listing)
15	54712	1.00	SPACER BAR,STEERING POST CLAMP
16	54782	1.00	DRUM/YOKE ASSY,FRONT (See Listing)
17	54870	1.00	HORN GROUP (See Listing)
18	54917	1.00	FRAME W/M,DELUXE,HONDA,13 HP
21	54956	1.00	SCRAPER GROUP,DELUXE,HONDA (See Listing)
22	54959	1.00	HARNESS,WIRE,HONDA 13HP,DELUXE (See Listing)
23	54961	1.00	COVER,FRONT,W/M
25	6156	2.00	ROD END,SPHER,.750-16
28	70437	1.00	BATTERY BOOT,POS(RED)
29	70584	1.00	THRUST BEARING,2.00X3.00X.25
30	71627	1.00	CSHH,.500-13X1.50,GR5
32	71792	1.00	CABLE,THROTTLE,3.00 TRAVELX70
36	71937	1.00	WHEEL,STEERING,17.00 OD
NS	71077	1.00	CAP,ST WL
38	72229	1.00	GEAR,SAGINAW STEERING (See Listing)
39	72666	1.00	CABLE,T HANDLE (CHOKE)
44	80096	2.00	NUT,HEX,JAM,.750-16
46	80141	17.00	WASHER,TYPE A PLAIN,.312
47	80142	17.00	WASHER,TYPE A PLAIN,.375
49	80160	8.00	WASHER,SPLIT LOCK,.250
50	80161	8.00	WASHER,SPLIT LOCK,.312
52	80164	9.00	WASHER,SPLIT LOCK,.500
53	81154	2.00	WASHER,SAE,HARDENED,.750
54	80186	3.00	CSHH,.500-13X1.75,GR5
57	80207	8.00	CSHH,.312-18X.75,GR5
58	80216	2.00	CSHH,.312-18X3.00,GR5
66	80351	12.00	NUT,FLEXLOC,.312-18,FULL,LT
67	80352	17.00	NUT,FLEXLOC,.375-16,FULL,LT
68	80354	9.00	NUT,FLEXLOC,.500-13,FULL,LT
69	80393	2.00	CSHH,.375-16X9.50,GR5
73	871111605	6.00	CLAMP,LOOP,.50 OD PLSTC COVER
86	C318H	1.00	COVER,STEERING COLUMN
90	D176	1.00	ROD,STEERING
91	D622H	1.00	BAR,POST CLAMP
97	R40	1.00	PIVOT CAP, FRONT
98	R440	1.00	BATTERY,12 VOLT,325 CCA
99	R441	1.00	HOLD DOWN,BATTERY
100	R442	1.00	CABLE,BATTERY,NEG,14,4GA,.406
111	72716	1.00	GAUGE,HOUR METER,INHIBITED
112	72659	1.00	SWITCH, IGNITION,6 TERM,3 POS
113	72718	2.3'	TRIM, RUBBER,PUSH ON
114	80909	3.00	SCR,SLFORL,HH,.250-14X1.00

**GROUP 1**



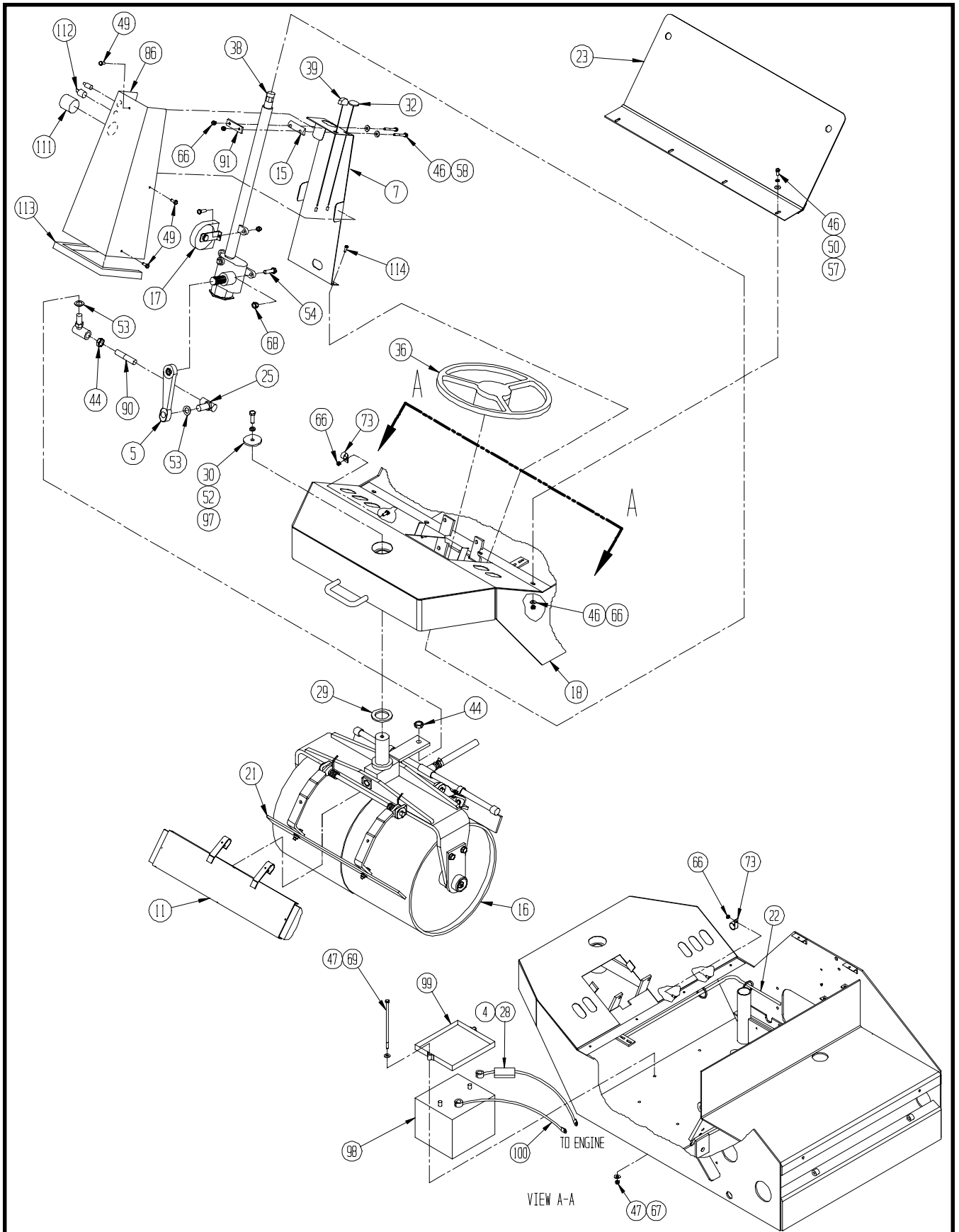

# GROUP 1

ITEM	PART NUMBER	QTY	DESCRIPTION
	<b>54916</b>	Rev. J1	<b>MAIN ASSEMBLY, HONDA</b>
1	31045	1.00	FITT,90 10MJ-10MB
2	33063	1.00	U-BOLT,.250-20,1.12IW,2.00IL
3	33163	3.00	CLAMP,HOSE,.50-.91,WORM,#08
8	52928	1.00	FOOT MOUNT W/M
9	52932	2.00	ANTI VIBRATION PAD
10	70318	1.00	FITT,STR 08MP-08HB,BLK POLY
13	54709	2.00	HANDLE EXT W/M
14	54711	2.00	VALVE HANDLE REWORK,.5 BALL
20	54954	1.00	COVER, TOP
26	6352	6.00	HOSE,08,PUSH-ON,250
27	70319	3.00	FITT,90 08MP-08HB,POLY
33	71800	1.00	FITT,90-LL 06MJ-04MP
35	71906	1.00	FITT,90 06MJ-04MB
36	71937	1.00	WHEEL,STEERING,17.00 OD
37	71953	2.00	SET S.SQ,.500-13X3.5
43	80076	2.00	NUT,HEX,JAM,.500-13
45	80140	12.00	WASHER,TYPE A PLAIN,.250
46	80141	17.00	WASHER,TYPE A PLAIN,.312
47	80142	17.00	WASHER,TYPE A PLAIN,.375
48	80144	4.00	WASHER,TYPE A PLAIN,.500
50	80161	8.00	WASHER,SPLIT LOCK,.312
55	80187	2.00	CSHH,.250-20X1.25,GR5
56	80192	8.00	CSHH,.250-20X.75,GR5
57	80207	8.00	CSHH,.312-18X.75,GR5
59	80221	7.00	CSHH,.375-16X1.00,GR5
60	80224	2.00	CSHH,.375-16X1.25,GR5
61	80228	7.00	CSHH,.375-16X1.75,GR5
63	80255	2.00	CSHH,.500-13X2.00,GR5
65	80350	4.00	NUT,FLEXLOC,.250-20,FULL,LT
67	80352	17.00	NUT,FLEXLOC,.375-16,FULL,LT
68	80354	9.00	NUT,FLEXLOC,.500-13,FULL,LT
73	871111605	6.00	CLAMP,LOOP,.50 OD PLSTC COVER
76	99569	1.00	PIPE,TEE,08FP,MI
77	99596	2.00	PIPE,NIPPLE,08XCLOSE
78	C254H	1.00	SPRING,SCRAPER BAR
85	C297H	1.00	SPROCKET,REWORK
87	D111X	1.00	SEAT POST,INNER
92	D652H	2.00	SIDE LH
94	R129	1.00	SLAT,SPRING
101	X218	1.00	COOLER,OIL
103	X388	1.00	FITT,90 06MJ-04MP
104	X392	2.00	FITT,STR 10MJ-10MB
105	X401	1.00	FITT,90 10MJ-10FJX
106	X405	1.00	MOTOR,HYD
107	80257	4.00	CSHH,.500-13X2.25,GR5
109	80185	1.00	CSHH,.250-20X1.00,GR5
110	54986	1.00	STRIP,EXHAUST TUBE SUPPORT
115	81155	8.00	WASHER,SAE,HARDENED,.375
<b>GROUP 1</b>			

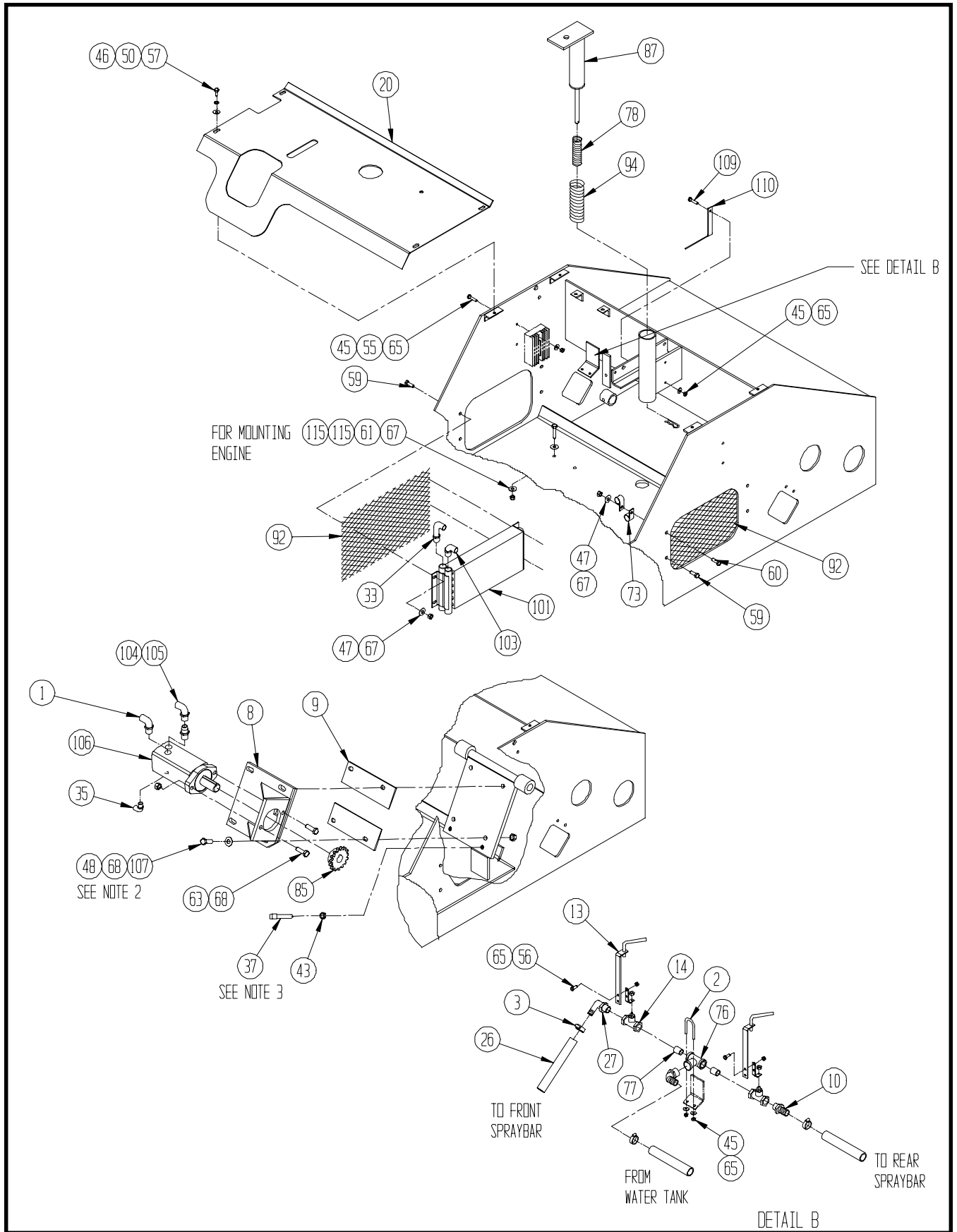

**GROUP 1**

ITEM	PART NUMBER	QTY	DESCRIPTION
	<b>54916</b>	Rev. J1	<b>MAIN ASSEMBLY, HONDA</b>
6	52497	1.00	ROD,EMERGENCY BRAKE HANDLE
12	54633	1.00	SPACER,BRAKE,DELUXE
31	71714	1.00	PIN,COTTER,.094X.750
34	71846	1.00	CHAIN,W/CONN & OFFSET LINK
41	80073	2.00	NUT,HEX,JAM,.312-18
42	80074	1.00	NUT,HEX,JAM,.375-16
46	80141	17.00	WASHER,TYPE A PLAIN,.312
47	80142	17.00	WASHER,TYPE A PLAIN,.375
50	80161	8.00	WASHER,SPLIT LOCK,.312
51	80162	1.00	WASHER,SPLIT LOCK,.375
52	80164	9.00	WASHER,SPLIT LOCK,.500
60	80224	2.00	CSHH,.375-16X1.25,GR5
61	80228	7.00	CSHH,.375-16X1.75,GR5
62	80250	4.00	CSHH,.500-13X1.25,GR5
64	80259	4.00	CSHH,.500-20X2.25,GR5
67	80352	17.00	NUT,FLEXLOC,.375-16,FULL,LT
70	80406	2.00	CSHH,.375-16X2.25,GR5
71	80821	1.00	COTTER PIN,.125X.75
72	80969	3.00	WASHER,SAE PLAIN,1.250
79	C259H	1.00	ANCHOR,EMERGENCY BRAKE HANDLE
80	C261HX	1.00	PULL BAR ASSY
81	C265H	1.00	DISC,BRAKE,DELUXE
82	C266H	4.00	TUBE,RND,1.00X.216X.875,SMLS
84	C280H	1.00	PIN,CLEVIS,.250X.750
88	D114X	1.00	DRUM,REAR,DELUXE III
89	D134	1.00	AXLE REAR
93	D660H	1.00	LEVER,BRAKE
95	R26-5-84	1.00	SPROCKET
96	R28	2.00	BEARING,FLANGE,1.250
102	X233	1.00	BRAKE ASSY (REWORKED)
	71053	2.00	BRAKE PADS
108	80387	4.00	CSHH,.500-20X1.25,GR5
	<b>54870</b>	REV. Ø	<b>HORN GROUP</b>
NS	33271-1	4.00	WIRE,16 GA,BLACK
NS	33382	1.00	SWITCH,STARTER PUSH BUTTON
NS	33593	4.00	LOOM,,SPRIAL CUT,.25 OD,NATURAL
NS	33600	1.00	TERM,PUSH-ON,.25,FEM,16-14 GA
NS	33601	1.00	TERM,BULLET,.156 STD,16-14 GA
NS	851390204	1.00	TERM,RING,16-14 GA, #10 STUD
NS	951250115	1.00	KIT,HORN
<b>GROUP 1</b>			

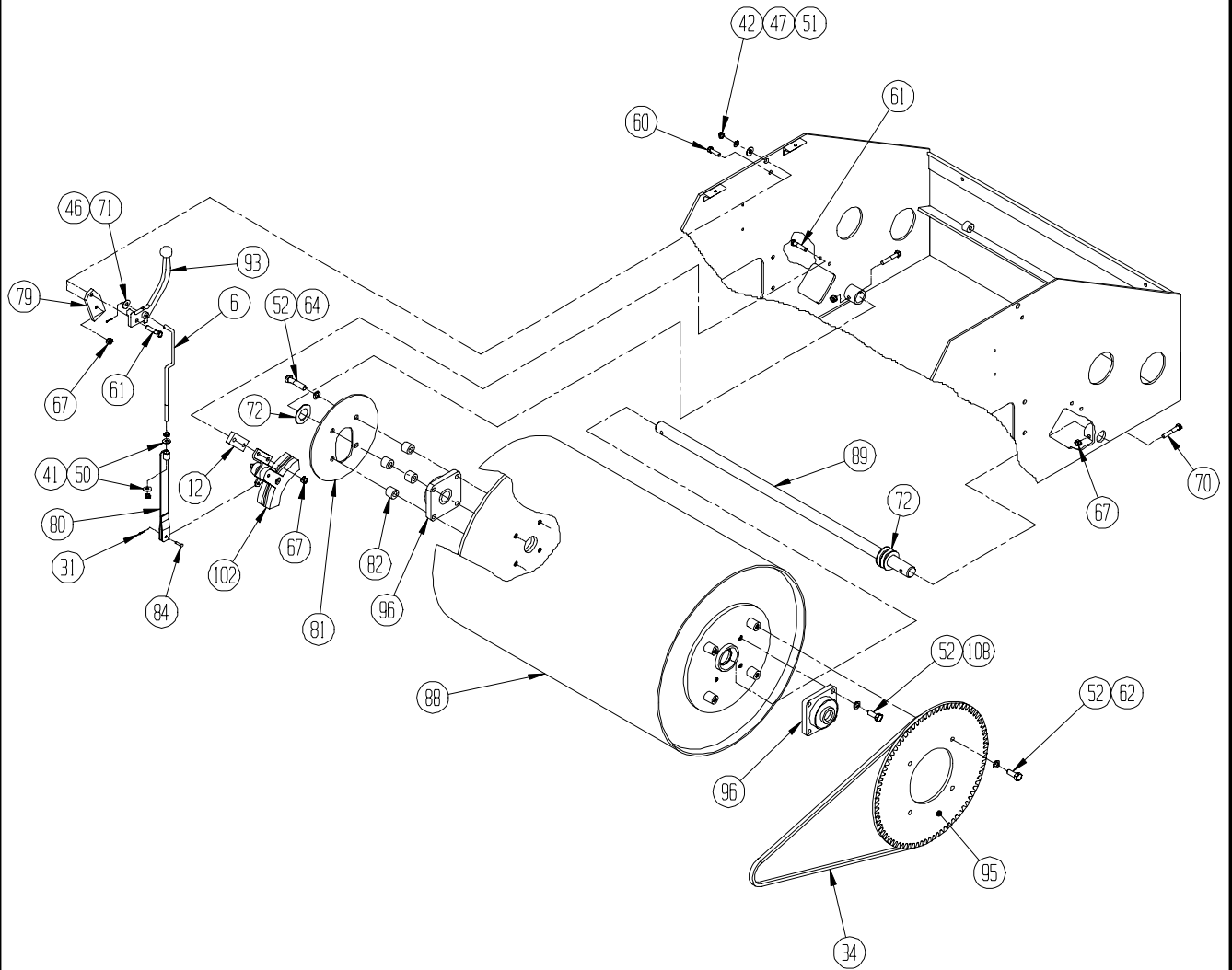

**GROUP 1**

ITEM	PART NUMBER	QTY	DESCRIPTION
	<b>54918</b>	<b>Rev. C</b>	<b>ENGINE ASSEMBLY, HONDA</b>
1	23232	1.00	BRKT,ENGINE LIFT,HONDA,13HP
2	31109	1.00	FITT,STR 08FJX-08HB,PUSH-ON
3	33162	2.00	CLAMP,HOSE,.44-.78,WORM,#06
4	33163	1.00	CLAMP,HOSE,.50-.91,WORM,#08
5	33284	2.00	FITT,STR 12FJX-12HB,PUSH-ON
6	33328	1.00	FITT,90 08MP-08HB,CRIMPED
7	34072	2.00	FITT,90 12MJ-12MP
8	37278	1.00	ENGINE,HONDA,13 HP,GAS
9	37278-01	1.00	STAY,CHOKE CONTROL,FOR CABLE
10	54679	1.00	KEY,SQ,.250X.875
11	54690	1.00	HYD TANK W/M,ROLLER
12	54966	1.00	EXHAUST TUBE W/M,DELUXE
13	6352	1.00	HOSE,08,PUSH-ON,250
14	6451	1.00	FILLER,BREATHER,-3 SCREEN
15	71832	1.00	MOUNT,PUMP
16	72662	1.00	CPLG,FLEX,MODEL 300,1.00 BORE
17	72663	1.00	CPLG,FLEX,MODEL 300,.75 BORE
18	72664	1.00	CPLG,INSERT,HYTREL 370H
19	72669	2.00	HOSE,08X34,10FJX(2),3500
20	80140	1.00	WASHER,TYPE A PLAIN,.250
21	80142	2.00	WASHER,TYPE A PLAIN,.375
22	80160	1.00	WASHER,SPLIT LOCK,.250
23	80162	4.00	WASHER,SPLIT LOCK,.375
24	80164	2.00	WASHER,SPLIT LOCK,.500
25	80192	1.00	CSHH,.250-20X.75,GR5
26	80224	4.00	CSHH,.375-16X1.25,GR5
27	80503	2.00	CSSH,.500-13X1.75
28	871111602	2.00	CLAMP,LOOP,.75 OD,PLSTC COVER
29	X216	6.00	FITT,STR 06FJX-06HB,PUSH-ON
30	X259	1.00	FILTER ASSY (FILTER AND ELEMENT)
NS	X260	1.00	FILTER ONLY
31	X274	1.00	FITT,45 08MJ-08MB
32	X296	2.00	FITT,STR 12MP-12HB,BRASS
33	X339	2.00	HOSE,12,HYD,300
34	X341	7.00	HOSE,06,PUSH-ON,250,BLUE
35	X371	1.00	PUMP,RH 1000PSI
36	X382	1.00	FITT,90 08MB-12FPX
37	X383	1.00	FITT,90 06MJ-06MP
38	X393	2.00	FITT,90 06MB-06HB
39	X425	2.00	FITT,45 10MJ-08MB
40	72370	2.00	FITT,TEST 04MB-02PD
41	72372	3.00	FITT,PLUG 02PD,DUST
42	72702	1.00	FITT,TEST 02MP-02PD
43	RES1001	0.00	HYDRAULIC SPECIFICATIONS
44	853210112	1.00	FITT,STR 02MP-02FP
45	71719	3.00	MACH SRC,PH,#8-32X.50
46	80793	3.00	NUT,HEX,#8-32
47	81014	3.00	WASHER,TYPE A PLAIN,#8
<b>GROUP 1</b>			

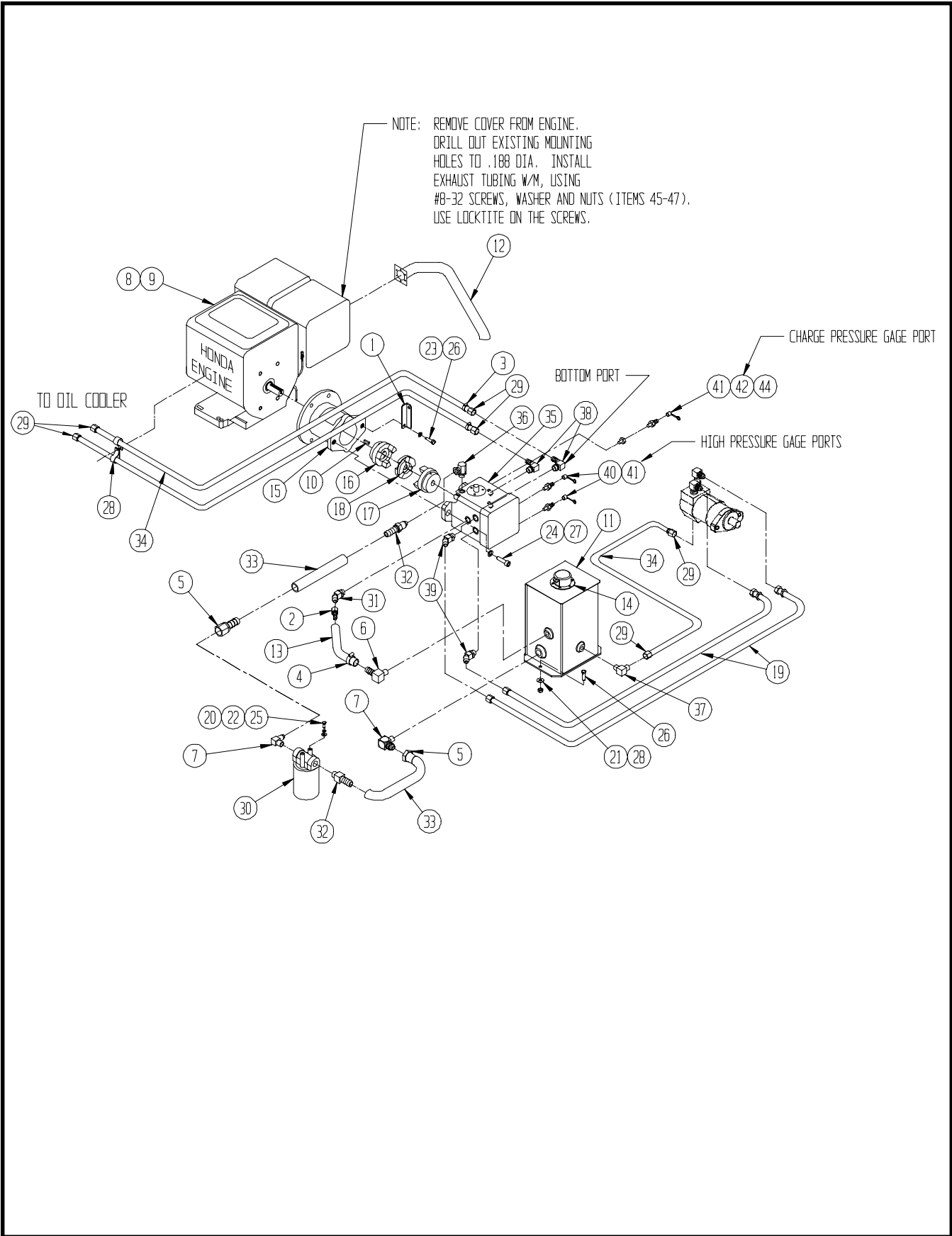

**GROUP 1**

ITEM	PART NUMBER	QTY	DESCRIPTION
	<b>55014</b>	<b>Rev. Ø</b>	<b>WIRE HARNESS, HONDA</b>
1	33271-1	5.50	WIRE,16 GA,BLACK
2	33271-12	6.25	WIRE,16 GA,RED/BLACK STRIPE
3	33271-13	6.58	WIRE,16 GA,BLACK/YELLOW STRIPE
4	33271-14	5.66	WIRE,16 GA,YELLOW/RED STRIPE
5	33271-17	7.41	WIRE,16 GA,WHITE/BLACK STRIPE
6	33271-2	5.33	WIRE,16 GA,YELLOW
7	33271-3	0.91	WIRE,16 GA,BROWN
8	33271-4	0.75	WIRE,16 GA,GREEN
9	33271-6	4.75	WIRE,16 GA,ORANGE
10	33271-7	0.83	WIRE,16 GA,RED
11	33589	4.66	LOOM,SPLIT,CONVOLUTED,.500
12	33599	1.00	TERM,PUSH-ON,.25,MALE,16-14GA
13	33601	3.00	CONN,BULLET,.156 STD,16-14 GA
14	33607	1.00	TERM,RING,16-14 GA,.250 STUD
15	33613	2.00	CONN,LINE,.156 STD,22-18 GA
16	36340	1.00	FUSE,BLADE,10AMP,ATC-10
17	36349	3.00	TERM,PUSH-ON,.25,FEM,18-14,SLV
18	37118	1.00	FUSE HOLDER,IN-LINE,BLADE,SEAL
19	37422	4.00	TERM,SOLDER SPLICE,20-10 AWG
20	71060	3.87	LOOM,SPLIT,CONVOLUTED,.250
21	71862	6.25	WIRE,14 GA,WHITE
22	72719	1.00	CONNECTOR,5 WAY,FEMALE
23	72720	5.00	TERM,PUSH ON,FEMALE,STRAIGHT
24	851390204	2.00	TERM,RING,16-14 GA,#10 STUD

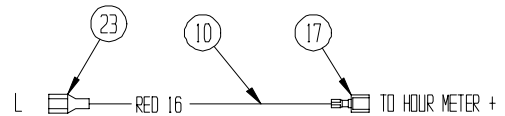
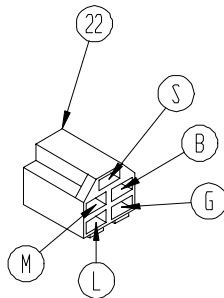

**GROUP 1**



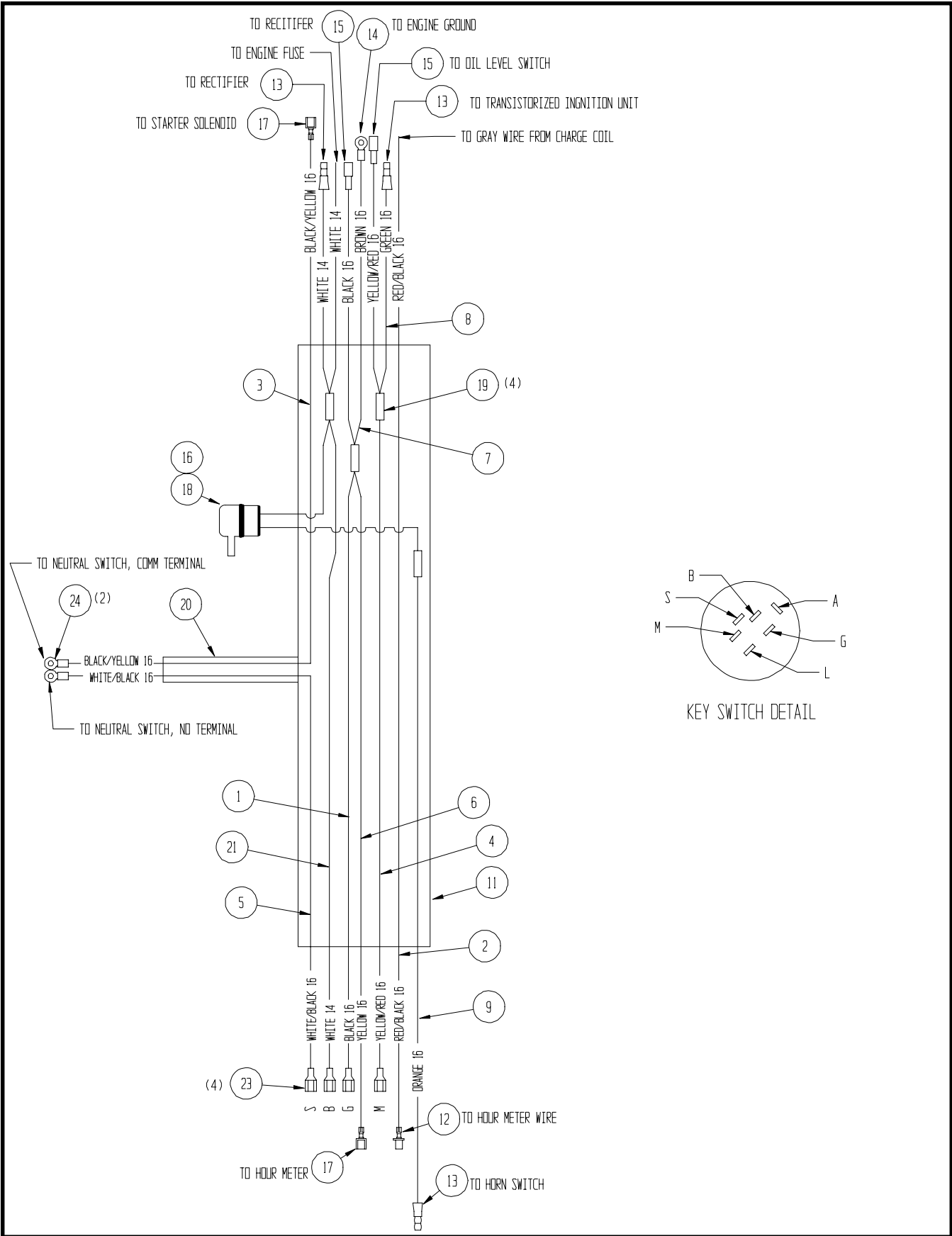

**GROUP 1**

ITEM	PART NUMBER	QTY	DESCRIPTION
	<b>54927</b>	<b>REV. F</b>	<b>FINAL ASSEMBLY, HONDA</b>
2	33163	1.00	CLAMP,HOSE,.50-.91,WORM,#08
4	34976	2.00	DECAL,DELUXE
6	36151	1.00	FILLER,TANK,4 IN
10	53053	1.00	SERIAL NUMBER PLATE,DELUXE
11	54607	2.00	DECAL,ROLLPAC III
12	54608	7.50	STRIPE,BLACK,2.50
13	54960	2.00	STRAP,DELUXE WATER TANK
14	6352	0.50	HOSE,08,PUSH-ON,250
15	6576	1.00	SEAT,BLACK W/ROSCO LOGO
16	70319	1.00	FITT,90 08MP-08HB,POLY
17	71077	1.00	CAP,ST WL,REF 6436
19	72670	1.00	TANK,WATER,DELUXE,35 GALLON
22	72678	1.00	DECAL,WATER ONLY
24	72680	1.00	DECAL,STARTING INSTRUCTIONS
25	72681	1.00	DECAL,WARNING,READ OPR MANUAL
28	72686	1.00	DECAL,WATER CONTROL VALVE
30	80142	6.00	WASHER,TYPE A PLAIN,.375
31	80144	1.00	WASHER,TYPE A PLAIN,.500
32	80164	1.00	WASHER,SPLIT LOCK,.500
33	80224	2.00	CSHH,.375-16X1.25,GR5
34	80248	1.00	CSHH,.500-13X1.00,GR5
35	80352	4.00	NUT,FLEXLOC,.375-16,FULL,LT
36	81165	2.00	TACK,DIA .109X.020 GRIP LENGTH
38	37684	1.00	DECAL,HYD OIL,FILL TO SCREEN
39	D48	2.00	DECAL,ROSCO LOGO,SMALL,BLACK
41	R135	1.00	RUBBER GRIP
<b>GROUP 1</b>			

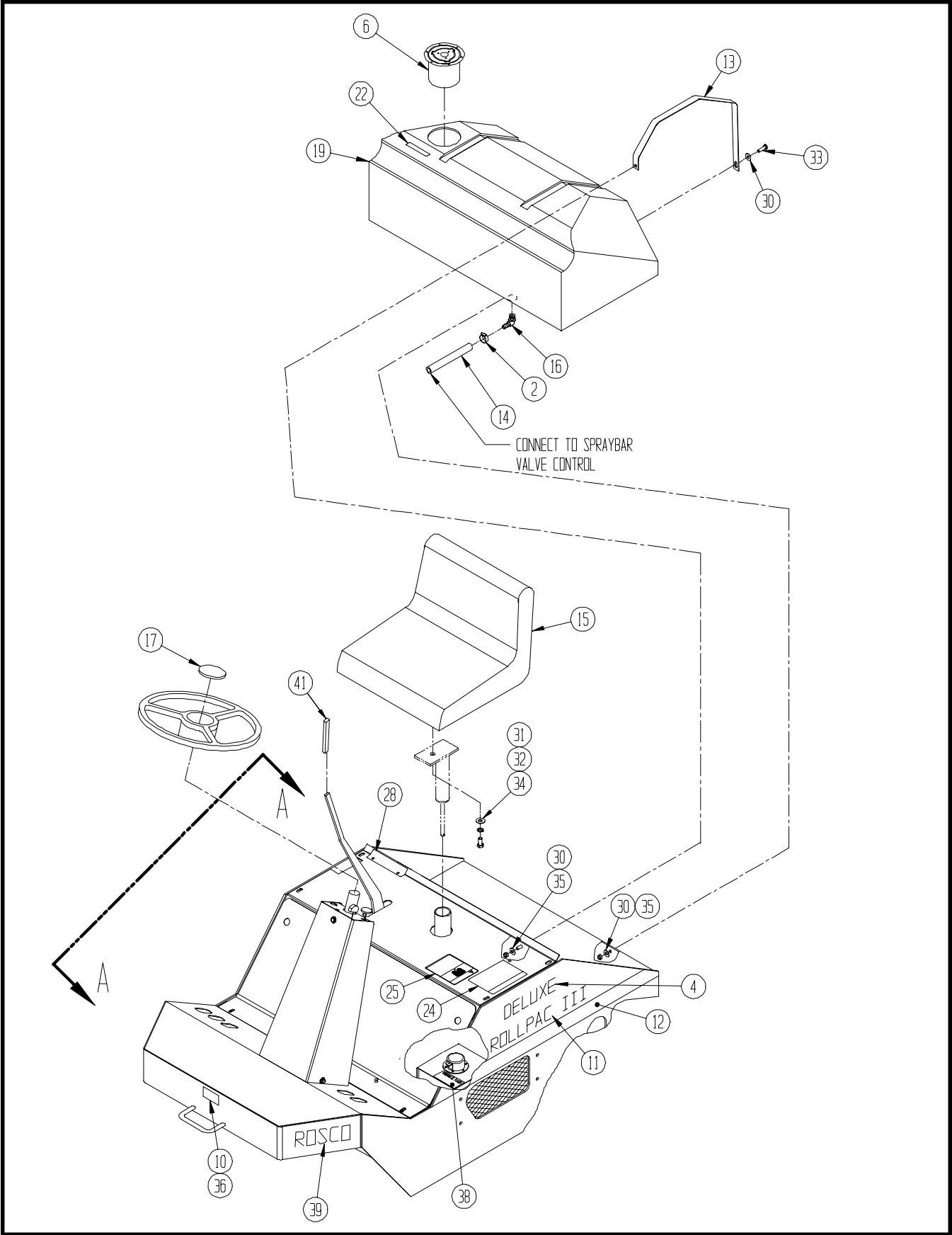

**GROUP 1**

ITEM	PART NUMBER	QTY	DESCRIPTION
	<b>54927</b>	<b>REV. F</b>	<b>FINAL ASSEMBLY, HONDA</b>
1	004684102	4.67	STRIP,ABRASIVE,4"X60'ROLL,BLK
3	33630-1	2.16	STRIPPING,.125
4	34976	2.00	DECAL,DELUXE
5	35244	1.67	STRIP,ADH SPONGE,75X.062
7	36195	1.00	DECAL SET,CONTROL
8	36346	1.00	DECAL,DRIVE CHAIN INSTRUCTION
9	37243	1.00	DECAL,WARNING,ENGINE EXHAUST
11	54607	2.00	DECAL,ROLLPAC III
12	54608	7.50	STRIPE,BLACK,2.50
18	72627	1.00	DECAL,WARNING,BATTERY INJURY
20	72676	1.00	DECAL,CAUTION,CLOSE FUEL VALVE
21	72677	1.00	DECAL,GASOLINE
23	72679	1.00	DECAL,CAUTION,15 PERCENT GRADE
26	72682	1.00	DECAL,WARNING,ENGINE COVERS
27	72683	1.00	DECAL,WARNING,LEVER MOVEMENT
29	72687	1.00	DECAL,HYDRAULIC WARRANTY VOID
39	D48	2.00	DECAL,ROSCO LOGO,SMALL,BLACK
40	D52	1.00	DECAL,PARKING BRAKE
42	72701	1.00	DECAL,FUEL,STRAIGHT GASOLINE
<b>GROUP 1</b>			

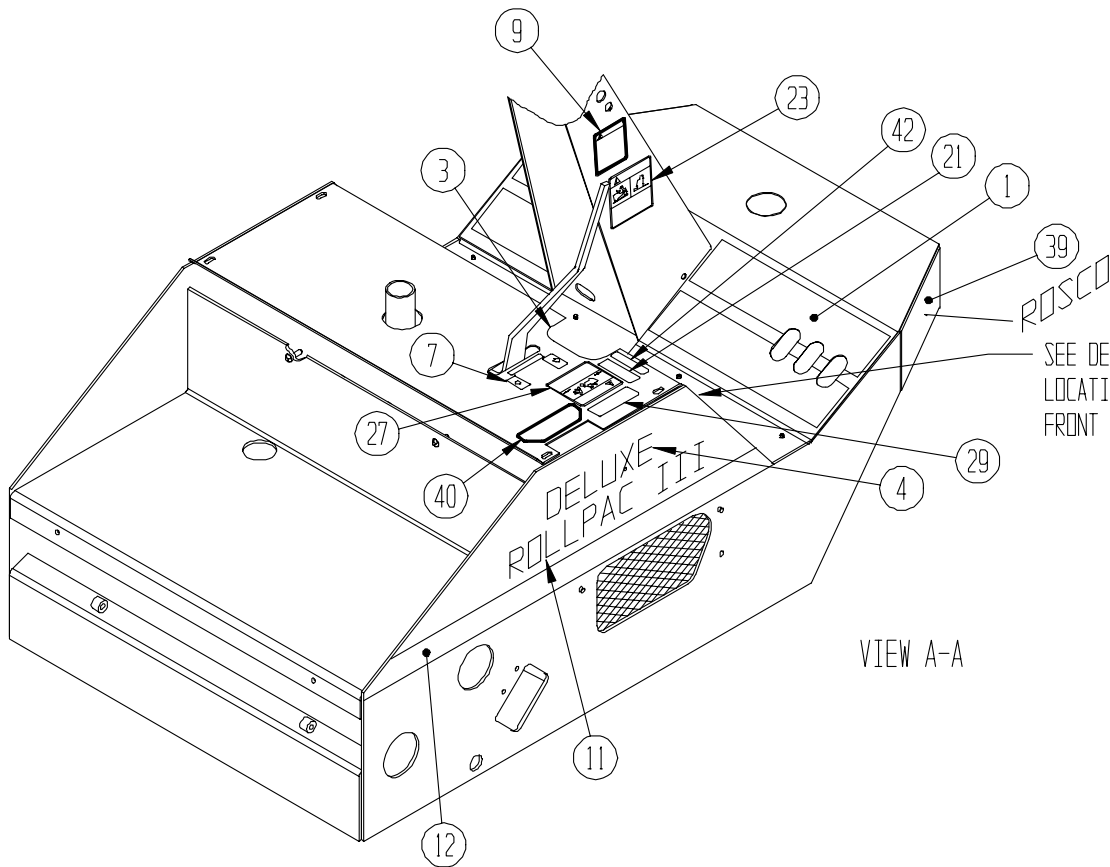

SEE DETAIL B FOR DECAL LOCATION ON INSIDE OF FRONT COVER

VIEW A-A

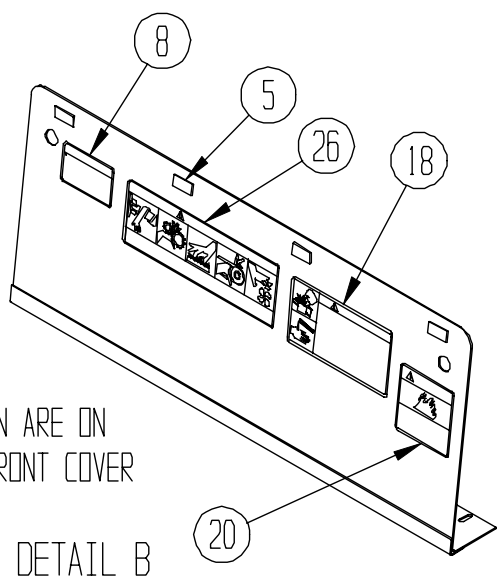

DECALS SHOWN ARE ON INSIDE OF FRONT COVER

DETAIL B



**GROUP 1**

ITEM	PART NUMBER	QTY	DESCRIPTION
	<b>54956</b>	<b>REV A</b>	<b>STEEL SCRAPER GROUP - REAR</b>
3	54957	2.00	ROD,SCRAPER BAR,.625X21.63
8	80146	4.00	WASHER,TYPE A PLAIN,.625
13	80851	2.00	COTTER PIN,.188X1.00
15	C254H	2.00	SPRING,SCRAPER BAR
16	C258HX	1.00	SCRAPER BAR ASSY,REAR
NS	54980	1.00	SPRAYBAR ASSY,REAR,DELUXE
NS	871111602	AR	CLAMP,LOOP,.75 OD,PLSTC COVER
NS	33163	AR	CLAMP,HOSE,.50-.91,WORM,#08
NS	80208	AR	CSHH,.312-18X1.00,GR5
NS	80351	AR	NUT,FLEXLOC,.312-18,FULL,LT
NS	70319	1.00	FITT,90,08MP-08HB,POLY
	<b>54596</b>	<b>REV</b>	<b>COCO MAT GROUP</b>
1	70414	24.00	RING,HOG
26	C262HX	1.00	COCO MAT FRAME ASSY,REAR
29	X199	1.00	COCO MAT 4X34
NS	80226	2.00	CSHH,.375-16X1.50, GR5
NS	80352	2.00	NUT,FLEXLOC,.375-16,FULL,LT
<b>GROUP 2</b>			

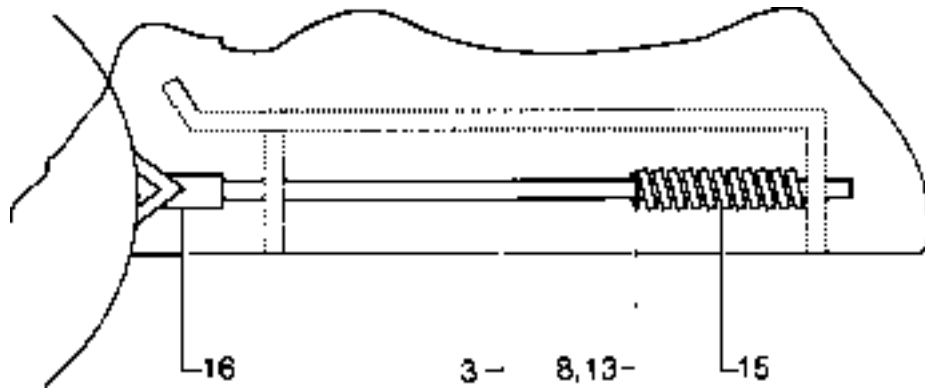

SIDE VIEW CUTAWAY

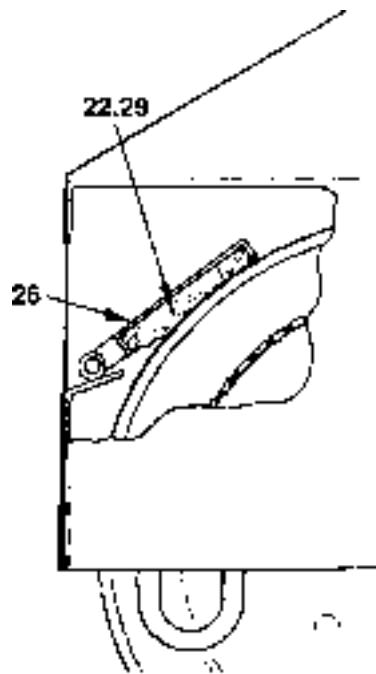

COCO MAT SIDE VIEW CUTAWAY



GROUP 2

ITEM	PART NUMBER	QTY	DESCRIPTION
	<b>54782</b>	<b>REV D</b>	<b>FRONT DRUM/YOKE ASSEMBLY</b>
1	53529	2.00	SPACER,2.50 ODX1.562 IDX.048 T
2	54675	2.00	SPACER,2.50 ODX1.562 IDX.029 T
3	54776	2.00	COLLAR PLATE,DELUXE,AXLE W/M
4	54778	1.00	YOKE W/M FRONT DELUXE
5	54779	1.00	YOKE,FRONT,AXLE 30.00
6	54804	1.00	PIN,KING W/M
7	54813	1.00	PIN,W/M PIVOT
8	80144	4.00	WASHER,TYPE A PLAIN,.500
9	80166	2.00	WASHER,SPLIT LOCK,.625
10	80186	4.00	CSHH,.500-13X1.75,GR5
11	80304	4.00	SET S,HSKT,KCUP,.375-16X.375
12	80340	1.00	COTTER PIN,.25X2.00
13	80354	4.00	NUT,FLEXLOC,.500-13,FULL,LT
14	80962	8.00	WASHER,DISC LOCK,.500
15	853750102	1.00	FITT,LUBE,STR,1/4-28
16	D182X	2.00	FRONT DRUM - DELUXE III
17	D185	5.00	SPACER,2.50 ODX1.562 IDX.134 T
18	D185-1	2.00	SPACER,2.50 ODX1.562 IDX.250 T
19	R48-1	1.00	WASHER,FLAT,1.50X1.031X.062
20	R48-2	1.00	WASHER,FLAT,1.50X1.031X.075
21	R48-3	1.00	WASHER,FLAT,1.50X1.031X.125
22	S147X	2.00	GREASE BOLT ASSY
23	X196	4.00	CONE
24	80697	2.00	WASHER,SAE PLAIN,.625

**NOTES:**

1. Install SAE Washer (Item #24) inside both ends of shaft, and torque bolt to 150 ft. lbs., loosen, retorque to 100 ft. lbs.
2. Install only shims shown. Use additional shims, (Items 1 & 2), only if required to obtain a gap of between .020 to .080 inch between drums. After Item # 22 has been torqued to specifications above (Note 1), rotate arms (Item #3) with a torque wrench. The reading should be between 10 and 50 in. lbs. If more then 50 in. lbs.,remove shims; if less then 10 in. lbs., add shims (Item 1 & 2).
3. Assemble drums, axle,bearings, spacers, and collar weldments separate from the yoke weldment. The yoke should just slip inside plates on collar weldments without bending yoke leg inward. Gap should be no more than .063 per side.
4. Torque to 75 ft. lbs.
5. Use 19,20, or 21 as required.
6. The difference in the diameters of drums must not exceed .020 when assembled.

**GROUP 2**



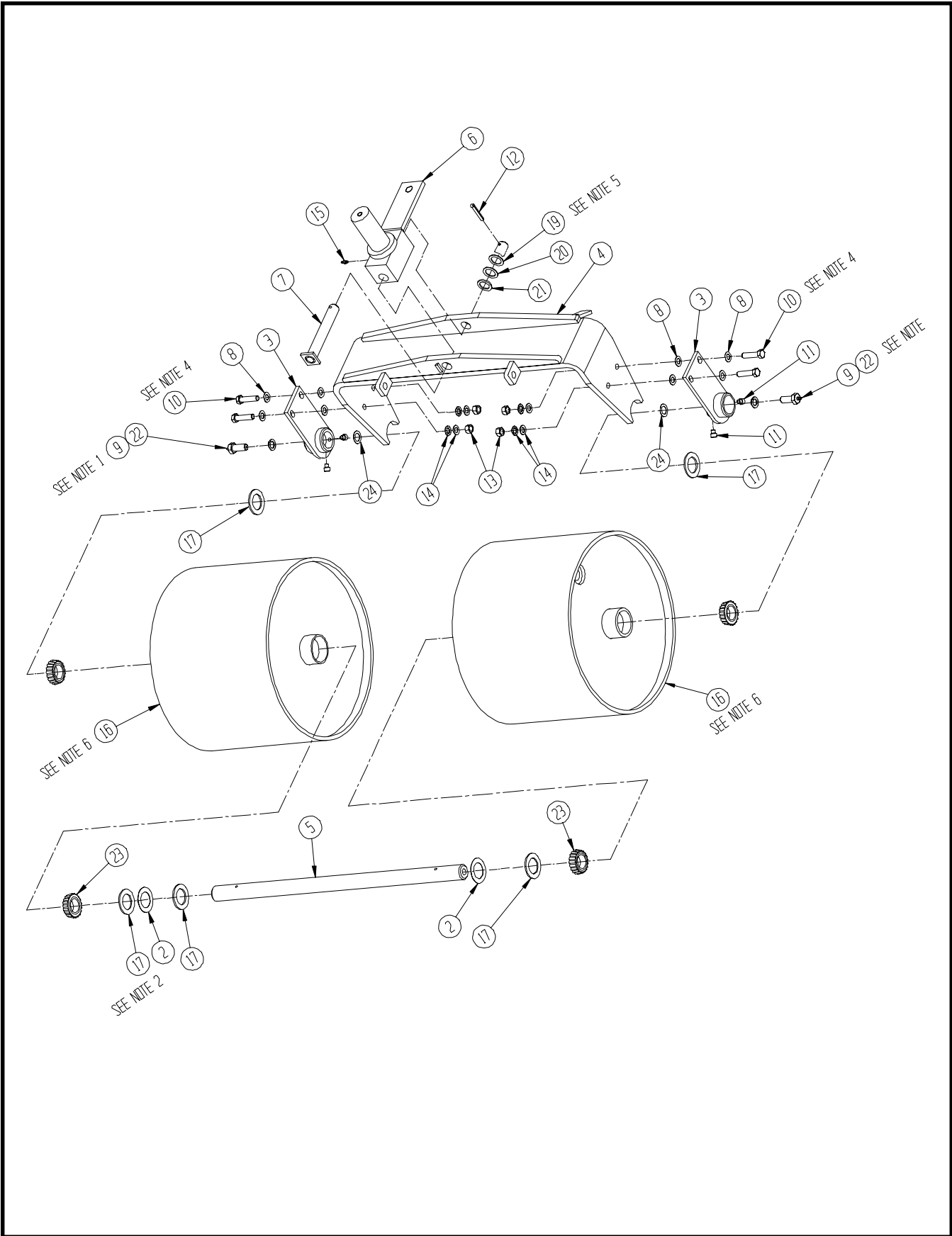

**GROUP 2**

ITEM	PART NUMBER	QTY	DESCRIPTION
	<b>54956</b>	<b>REV A</b>	<b>STEEL SCRAPER GROUP - FRONT</b>
2	53341	1.00	FRONT SCRAPER BAR
7	80142	2.00	WASHER,TYPE A PLAIN,.375
8	80146	4.00	WASHER,TYPE A PLAIN,.625
10	80226	2.00	CSHH,.375-16X1.50,GR5
12	80352	2.00	NUT,FLEXLOC,.375-16,FULL,LT
13	80851	2.00	COTTER PIN,.188X1.00
18	R335	1.00	ROD,SCRAPER
19	R339L	1.00	SPRING,LH
20	R339R	1.00	SPRING,RH
21	R540X	2.00	ARM ASSY
NS	C267HX	1.00	SPRAY BAR ASSY
NS	33163	AR	CLAMP,HOSE,.50-.91,WORM,#08
NS	871111602	AR	CLAMP,LOOP,.75 OD,PLSTC COVER
NS	80208	AR	CSHH,.312-18X1.00,GR5
NS	80351	AR	NUT,FLEXLOC,.312-18,FULL,LT
NS	70318	1.00	FITT,STR 08MP-08HB,BLK POLY
	<b>54596</b>	<b>REV</b>	<b>COCO MAT GROUP</b>
22	70414	24.00	RING,HOG
27	R586X	1.00	FRAME ASSY
28	X198	1.00	COCO MAT 4X28
NS	80338	2.00	COTTER PIN,.188X2.00
<b>GROUP 2</b>			

FRONT VIEW

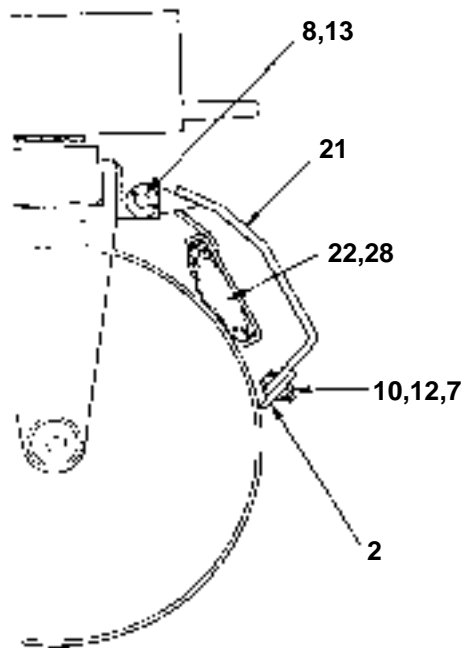
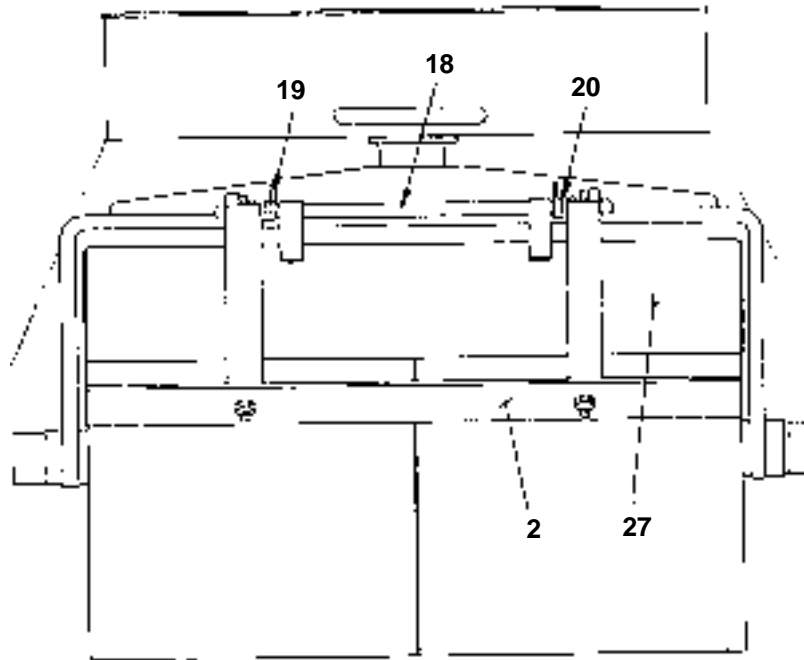

SIDE VIEW



GROUP 2

ITEM	PART NUMBER	QTY	DESCRIPTION
	<b>55030</b>	<b>REV. Ø</b>	<b>TRANSMISSION CONTROL LEVER ASSEMBLY</b>
1	36879	1.00	SWITCH,SNAP ACTING,W/ROLLER
2	53175	1.00	WASHER,NYLON,2.125 OD
3	54933	1.00	MOUNT W/M,CONTROL LEVER
4	54952	1.00	PUMP TUBE W/M,DELUXE
5	55027	1.00	LEVER,RH DIR CONTROL,DELUXE
6	X107	1.00	CLEVIS,#4YOKE,.375-24,W/#34PIN
7	5960-1	1.00	ROD END,SPHER,FEM,.375-24 LH
8	71952	1.00	HOSE ASSY 3000 PSI,-03 X 22
9	72660	1.00	FITT,LUBE,STR,02FP
10	80091	1.00	NUT,HEX,JAM,.375-24
11	80141	2.00	WASHER,TYPE A PLAIN,.312
12	80142	1.00	WASHER,TYPE A PLAIN,.375
13	80144	2.00	WASHER,TYPE A PLAIN,.500
14	80162	1.00	WASHER,SPLIT LOCK,.375
15	80189	1.00	CSHH,.500-13X2.75,GR5
16	80304	3.00	SET S,HSKT,KCUP,.375-16X.375
17	80208	2.00	CSHH,.312-18X1.00,GR5
18	846177210	3.00	SET SCREW DOG POINT
19	80351	2.00	NUT,FLEXLOC,.312-18,FULL,LT
20	80352	1.00	NUT,FLEXLOC,.375-16,FULL,LT
21	80354	1.00	NUT,FLEXLOC,.500-13,FULL,LT
22	80493	2.00	NUT,HEX,#6-32
23	80510	1.00	NUT,HEX,JAM,.375-24,LH
24	80927	2.00	MACH SCR,#6-32X1.25
25	81013	1.00	NUT,FLEXLOC,.375-24,THIN,LT
26	81014	2.00	WASHER,TYPE A PLAIN,#8
27	846082155	1.00	SPRING
28	871020103	1.00	CRG BOLT,.375-16X1.00,GR5
29	C300H	1.00	ROD,PUMP CONTROL,51353
30	80206	1.00	CSHH,.312-18X1.25,GR5
31	80073	2.00	NUT,HEX,JAM,.312-18
32	80202	1.00	CSHH,.312-18X.50,GR5
33	99523	1.00	PIPE,90,02MP-02FP,MI
NS	R135	1.00	RUBBER GRIP
<b>GROUP 2</b>			

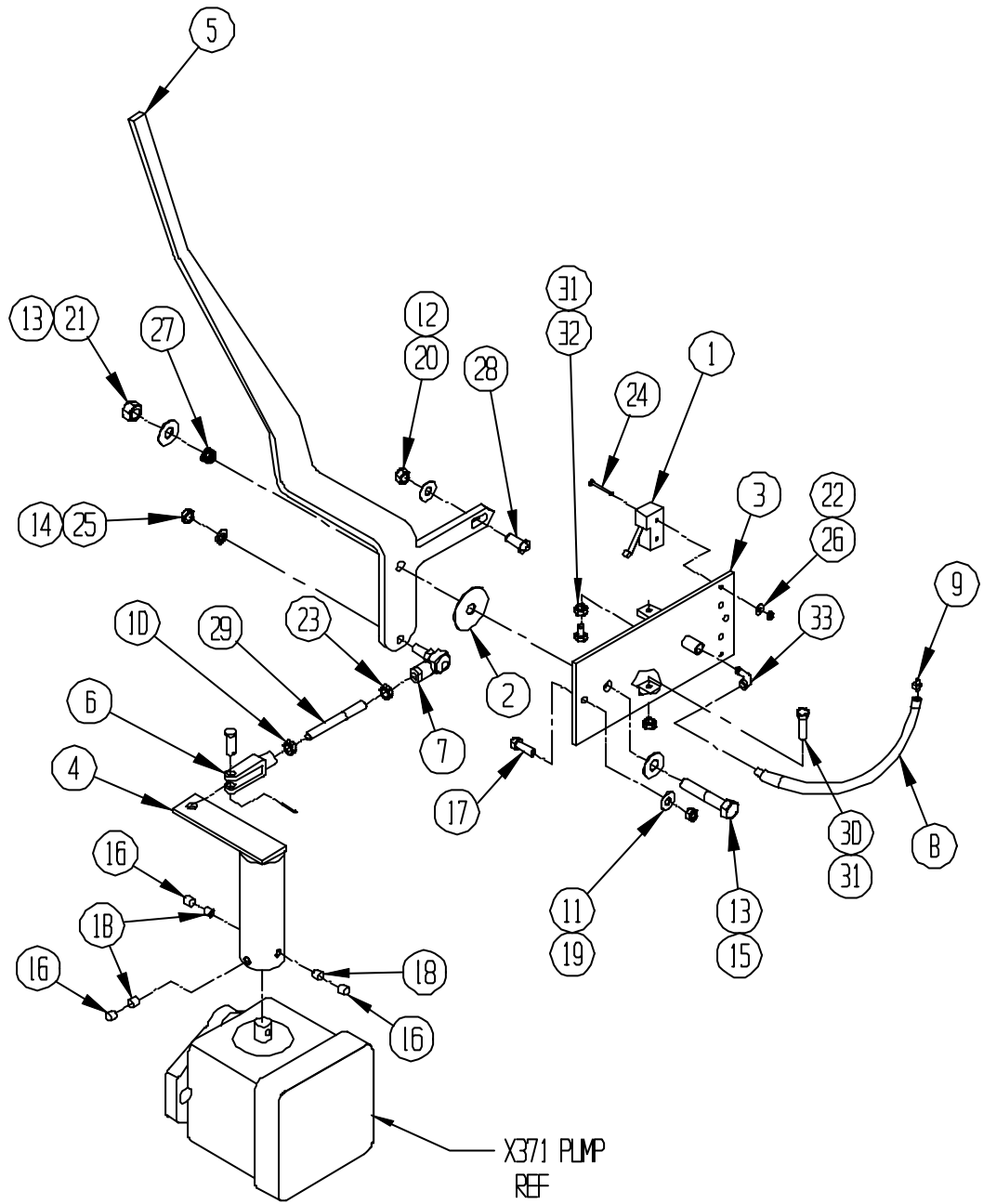

**GROUP 2**

ITEM	PART NUMBER	QTY	DESCRIPTION
	<b>72229</b>	<b>REV</b>	<b>STEERING GEAR (EXPLODED VIEW)</b>
1	SAG-1	1	LOCKNUT,ADJUSTER
2	SAG-2	1	WORM BEARING ADJUSTER
3	SAG-3	1	PITMAN SEAL (NOT SHOWN)
4	SAG-4	1	WORM SEAL
5	SAG-5	1	BALL NUT
6	SAG-6	1	WORM SHAFT
7	SAG-7	2	BEARING RACE
8	SAG-8	2	BEARING CUP
9	SAG-9	1	PITMAN NUT
10	SAG-10	1	BALL GUIDE CLAMP
11	SAG-11	1	HOUSING
12	SAG-12	1	PITMAN LOCKWASHER
14	SAG-14	1	GASKET
15	SAG-15	1	BUSHING,SECTOR SHAFT
16	SAG-16	1	SECTOR AND SHAFT
17	SAG-17	1	LASH ADJUSTER
18	SAG-18	AR	SHIM KIT,LASH ADJUSTER
19	SAG-19	1	HOUSING SLIDE COVER & BUSHING
22	SAG-22	3	SCREW,CLAMP BALL GUIDE
24	SAG-24	1	KIT,BALL GUIDE
25	SAG-25	54	BALL (54 = 1 SET)
NS	72229-02	1	JACKET
NS	71286	1.00	CLAMP,JACKET
NS	72229-03	1.00	SEAT,STEERING
NS	72229-04	1.00	SPRING,STEERING SHAFT
NS	71975	1.00	BEARING,COLUMN
NS	72229-06	1.00	WORM SHAFT & BALL NUT ASSEMBLY
			<i>(Includes Items 5,6,10,22,24 &amp; 25)</i>
<b>GROUP 2</b>			

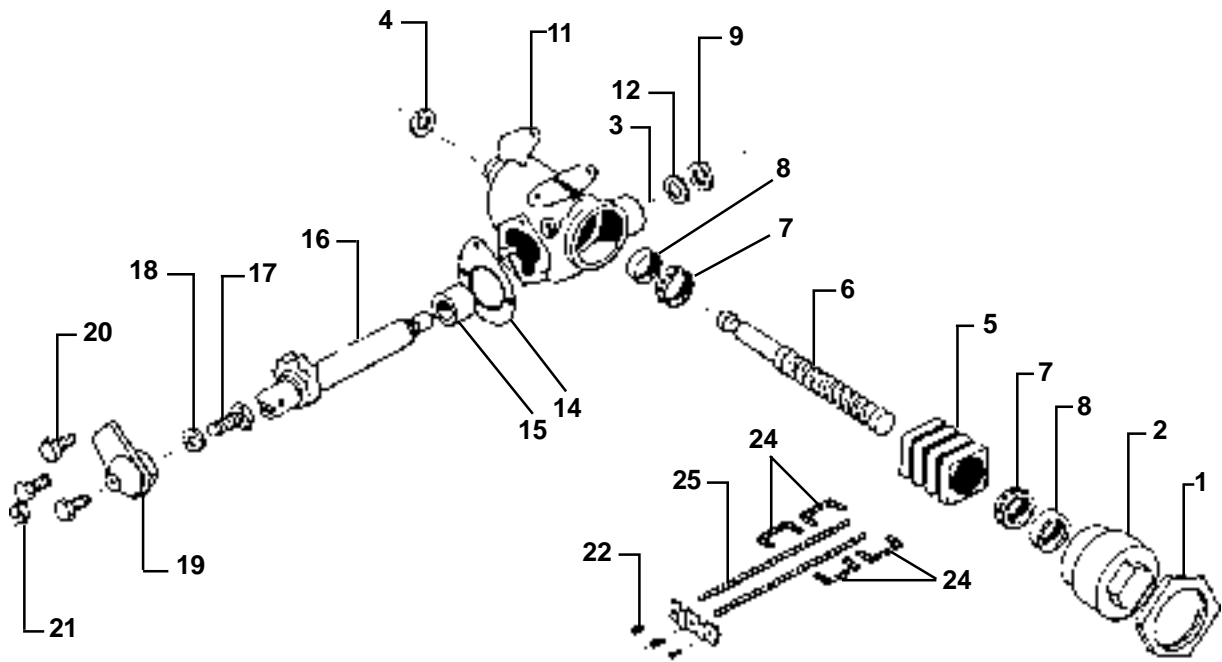

**GROUP 2**

ITEM	PART NUMBER	QTY	DESCRIPTION
	<b>55087</b>	<b>REV. 01</b>	<b>MAIN ASSEMBLY, KOHLER</b>
1	31045	1.00	FITT,90 10MJ-10MB
2	33063	1.00	U-BOLT,.250-20,1.12IW,2.00IL
3	33163	3.00	CLAMP,HOSE,.50-.91,WORM,#08
4	35228	1.00	CABLE,BATTERY,POS,4GAX14
5	51855	1.00	PITMAN ARM,REWORKED
6	52497	1.00	ROD,EMERGENCY BRAKE HANDLE
7	55012	1.00	FACE,STEERING CONSOLE,DELUXE
8	52928	1.00	FOOT MOUNT W/M
9	52932	2.00	ANTI VIBRATION PAD
10	70318	1.00	FITT,STR 08MP-08HB,BLK POLY
11	54596	1.00	COCO MAT GROUP,DELUXE (See Listing)
12	54633	1.00	SPACER,BRAKE,DELUXE
13	54709	2.00	HANDLE EXT W/M
14	54711	2.00	VALVE HANDLE REWORK,.5 BALL
15	54712	1.00	SPACER BAR,STEERING POST CLAMP
16	54782	1.00	DRUM/YOKE ASSY,FRONT (See Listing)
17	54870	1.00	HORN GROUP (See Listing)
18	54917	1.00	FRAME W/M,DELUXE,HONDA,13 HP
19	55088	1.00	ENGINE ASSY,D/L III,KOHLER 15 (See Listing)
20	55077	1.00	COVER,TOP,KOHLER 15
21	54956	1.00	SCRAPER GROUP,DELUXE,HONDA (See Listing)
22	55090	1.00	HARNESS,WIRE,D/L III,KOHLER 15 (See Listing)
23	55081	1.00	W/M,FRONT COVER,KOHLER 15
24	55030	1.00	RH CONTROL LEVER ASSY,DELUXE (See Listing)
25	6156	2.00	ROD END,SPHER,.750-16
26	6352	6.00	HOSE,08,PUSH-ON,250
27	70319	3.00	FITT,90 08MP-08HB,POLY
28	70437	1.00	BATTERY BOOT,POS(RED)
29	70584	1.00	THRUST BEARING,2.00X3.00X.25
30	71627	1.00	CSHH,.500-13X1.50,GR5
31	71714	1.00	PIN,COTTER,.094X.750
32	71792	1.00	CABLE,THROTTLE,3.00 TRAVELX70
33	71800	1.00	FITT,90-LL 06MJ-04MP
34	71846	1.00	CHAIN,W/CONN & OFFSET LINK
35	71906	1.00	FITT,90 06MJ-04MB
36	71937	1.00	WHEEL,STEERING,17.00 OD
37	71953	2.00	SET S,SQ,.500-13X3 1/2
38	72229	1.00	GEAR,SAGINAW STEERING (See Listing)
39	72666	1.00	CABLE,T HANDLE (CHOKE)
40	7303	1.00	HAIR PIN COTTER,#11,.125 DIA
41	80073	2.00	NUT,HEX,JAM,.312-18
42	80074	1.00	NUT,HEX,JAM,.375-16
			(cont.)
<b>GROUP 3</b>			

ITEM	PART NUMBER	QTY	DESCRIPTION
	<b>55087</b>	<b>REV. 01</b>	<b>MAIN ASSEMBLY, KOHLER</b>
43	80076	2.00	NUT,HEX,JAM,.500-13
44	80096	2.00	NUT,HEX,JAM,.750-16
45	80140	5.00	WASHER,TYPE A PLAIN,.250
46	80141	17.00	WASHER,TYPE A PLAIN,.312
47	80142	9.00	WASHER,TYPE A PLAIN,.375
48	80144	4.00	WASHER,TYPE A PLAIN,.500
49	81160	5.00	SCR,SLFDRL,HH,#10X1.00,#3PT
50	80161	8.00	WASHER,SPLIT LOCK,.312
51	80162	1.00	WASHER,SPLIT LOCK,.375
52	80164	9.00	WASHER,SPLIT LOCK,.500
53	81154	2.00	WASHER,SAE,HARDENED,.750
54	80186	3.00	CSHH,.500-13X1.75,GR5
55	80187	2.00	CSHH,.250-20X1.25,GR5
56	80192	4.00	CSHH,.250-20X.75,GR5
57	80207	8.00	CSHH,.312-18X.75,GR5
58	80216	2.00	CSHH,.312-18X3.00,GR5
59	80221	7.00	CSHH,.375-16X1.00,GR5
60	80224	2.00	CSHH,.375-16X1.25,GR5
61	80228	7.00	CSHH,.375-16X1.75,GR5
62	80250	4.00	CSHH,.500-13X1.25,GR5
63	80255	2.00	CSHH,.500-13X2.00,GR5
64	80259	4.00	CSHH,.500-20X2.25,GR5
65	80350	5.00	NUT,FLEXLOC,.250-20,FULL,LT
66	80351	12.00	NUT,FLEXLOC,.312-18,FULL,LT
67	80352	17.00	NUT,FLEXLOC,.375-16,FULL,LT
68	80354	9.00	NUT,FLEXLOC,.500-13,FULL,LT
69	80393	2.00	CSHH,.375-16X9.50,GR5
70	80406	2.00	CSHH,.375-16X2.25,GR5
71	80821	1.00	COTTER PIN,.125X.75
72	80969	3.00	WASHER,SAE PLAIN,1.250
73	871111605	6.00	CLAMP,LOOP,.50 OD PLSTC COVER
74	90735	3.00	OIL,HYDRAULIC,MULTI SERVICE
75	91340	.50	OIL,SAE 10W40 CC/CD
76	99569	1.00	PIPE,TEE,08FP,MI
77	99596	2.00	PIPE,NIPPLE,08XCLOSE
78	C254H	1.00	SPRING,SCRAPER BAR
79	C259H	1.00	ANCHOR,EMERGENCY BRAKE HANDLE
80	C261HX	1.00	PULL BAR ASSY
81	C265H	1.00	DISC,BRAKE,DELUXE
82	C266H	4.00	TUBE,RND,1.00X.216X.875,SMLS
84	C280H	1.00	PIN,CLEVIS,.250X.750
85	C297H	1.00	SPROCKET,REWORK
			<i>(cont.)</i>



**GROUP 3**

ITEM	PART NUMBER	QTY	DESCRIPTION
	<b>55087</b>	<b>REV. 01</b>	<b>MAIN ASSEMBLY, KOHLER</b>
86	55013	1.00	COVER,STEERING CONSOLE,DELUXE
87	D111X	1.00	SEAT POST,INNER
88	D114X	1.00	DRUM,REAR,D/L III,51842
89	D134	1.00	AXLE,REAR,1.25X38,DELUXE,50148
90	D176	1.00	ROD,STEERING
91	D622H	1.00	BAR,POST CLAMP
92	55094	2.00	SCREEN,OIL COOLER COVER
93	D660H	1.00	LEVER,BRAKE
94	R129	1.00	SLAT,SPRING
95	R26-5-84	1.00	SPROCKET
96	R28	2.00	BEARING,FLANGE,1.250
97	R40	1.00	PIVOT CAP, FRONT
98	R440	1.00	BATTERY,12V,325 CCA
99	R441	1.00	HOLD DOWN,BATTERY
100	R442	1.00	CABLE,BATTERY,NEG,14,4GA,.406
101	X218	1.00	COOLER,OIL
102	X233	1.00	BRAKE ASSY (REWORKED)
	71053	2.00	BRAKE PADS
103	X388	1.00	FITT,90 06MJ-04MP
104	X392	1.00	FITT,STR 10MJ-10MB
105	X401	1.00	FITT,90 10MJ-10FJX
106	X405	1.00	MOTOR,HYD
107	80257	4.00	CSHH,.500-13X2.25,GR5
108	80387	4.00	CSHH,.500-20X1.25,GR5
109	80185	1.00	CSHH,.250-20X1.00,GR5
111	72716	1.00	GAUGE,HOUR METER,INHIBITED
113	72718	2.30	TRIM,RUBBER,PUSH ON
114	80909	3.00	SCR,SLFDRL,HH,.250-14X1.00
115	37426	2.00	TERM,PUSH-ON,JUMPER,.25,16-14G
116	81155	8.00	WASHER,SAE,HARDENED,.375
	<b>54870</b>	<b>REV. Ø</b>	<b>HORN GROUP</b>
NS	33271-1	4.00	WIRE,16 GA,BLACK
NS	33382	1.00	SWITCH,STARTER PUSH BUTTON
NS	33593	4.00	LOOM,,SPRIAL CUT,.25 OD,NATURAL
NS	33600	1.00	TERM,PUSH-ON,.25,FEM,16-14 GA
NS	33601	1.00	TERM,BULLET,.156 STD,16-14 GA
NS	851390204	1.00	TERM,RING,16-14 GA, #10 STUD
NS	951250115	1.00	KIT,HORN
<b>GROUP 3</b>			

ITEM	PART NUMBER	QTY	DESCRIPTION
	<b>55088</b>	<b>REV. 01</b>	<b>ENGINE ASSEMBLY, KOHLER</b>
1	33306	2.00	CLAMP,MUFFLER,1.5
2	31109	1.00	FITT,STR 08FJX-08HB,PUSH-ON
3	33162	2.00	CLAMP,HOSE,.44-.78,WORM,#06
4	33163	1.00	CLAMP,HOSE,.50-.91,WORM,#08
5	33284	2.00	FITT,STR 12FJX-12HB,PUSH-ON
6	33328	1.00	FITT,90 08MP-08HB,CRIMPED
7	34072	2.00	FITT,90 12MJ-12MP
10	54679	1.00	KEY,SQ,.250X.875
11	54690	1.00	HYD TANK W/M,ROLLER
13	6352	1.00	HOSE,08,PUSH-ON,250
14	6451	1.00	FILLER,BREATHER,-3 SCREEN
15	71832	1.00	MOUNT,PUMP
16	72662	1.00	CPLG,FLEX,MODEL 300,1.00 BORE
17	72663	1.00	CPLG,FLEX,MODEL 300,.75 BORE
18	72664	1.00	CPLG,INSERT,HYTREL 370H
19	72669	2.00	HOSE,08X34,10FJX(2),3500
20	80140	1.00	WASHER,TYPE A PLAIN,.250
21	80142	2.00	WASHER,TYPE A PLAIN,.375
22	80160	1.00	WASHER,SPLIT LOCK,.250
23	80162	4.00	WASHER,SPLIT LOCK,.375
24	80164	2.00	WASHER,SPLIT LOCK,.500
25	80192	1.00	CSHH,.250-20X.75,GR5
26	80224	4.00	CSHH,.375-16X1.25,GR5
27	80503	2.00	CSSH,.500-13X1.75
29	X216	6.00	FITT,STR 06FJX-06HB,PUSH-ON
30	X259	1.00	FILTER ASSY (HydraulicSystem)
NS	X260	1.00	FILTER ONLY
31	X274	1.00	FITT,45 08MJ-08MB
32	X296	2.00	FITT,STR 12MP-12HB,BRASS
33	X339	2.00	HOSE,12,HYD,300
34	X341	7.00	HOSE,06,PUSH-ON,250,BLUE
35	X371	1.00	PUMP,RH 1000PSI
36	X382	1.00	FITT,90 08MB-12FPX
37	X383	1.00	FITT,90 06MJ-06MP
38	34591	2.00	FITT,STR 06MB-06HB
39	X425	2.00	FITT,45 10MJ-08MB
40	72370	2.00	FITT,TEST 04MB-02PD
41	72372	3.00	FITT,PLUG 02PD,DUST
42	72703	1.00	FITT,TEST 02FP-02PD
43	RES1001	.00	HYDRAULIC SPECIFICATIONS
44	90740	1.00	PIPE,NIPPLE,02X3.00,300#
50	72750	1.00	ENGINE,KOHLER,15 HP,GASOLINE

(cont.)





**GROUP 3**

ITEM	PART NUMBER	QTY	DESCRIPTION
	<b>55088</b>	<b>REV. 01</b>	<b>ENGINE ASSEMBLY, KOHLER</b>
51	72751	1.00	KIT,MUFFLER,KOHLER 15
52	72752	1.00	GASKET,EXHAUST,KOHLER 15
53	55085	1.00	W/M,EXH FLANGE,45,KOHLER 15
54	55084	1.00	W/M,EXH FLANGE,KOHLER 15
55	55083	1.00	MOUNT,UPPER,MUFFLER
56	55082	1.00	MOUNT,LOWER,MUFFLER
57	55091	1.00	TUBE,FLEX,EXH,1.50 ID,13.00 LG
	<b>55090</b>	<b>REV. A</b>	<b>ENGINE WIRE HARNESS, KOHLER (ILLUSTRATED)</b>
1	33271-11	3.16	WIRE,16 GA,BLUE
2	33271-12	9.50	WIRE,16 GA,RED/BLACK STRIPE
3	33271-13	10.33	WIRE,16 GA,BLACK/YELLOW STRIPE
4	33271-2	1.00	WIRE,16 GA,YELLOW
5	33271-3	4.16	WIRE,16 GA,BROWN
6	33271-4	9.66	WIRE,16 GA,GREEN
7	33271-5	9.33	WIRE,16 GA,WHITE
8	33271-6	7.08	WIRE,16 GA,ORANGE
9	33271-8	4.41	WIRE,16 GA,PINK
10	33271-9	9.33	WIRE,16 GA,PURPLE
11	33599	1.00	TERM,PUSH-ON,.25,MALE,16-14GA
12	33601	2.00	TERM,BULLET,.156 STD,16-14 GA
13	33608	1.00	TERM,RING,16-14 GA,.312 STUD
14	36340	1.00	FUSE,BLADE,10AMP,ATC-10
15	36348	1.00	TERM,PUSH-ON,.25,M,18-14,SLV
16	36349	4.00	TERM,PUSH-ON,.25,FEM,18-14,SLV
17	37118	1.00	FUSE HOLDER,IN-LINE,BLADE,SEAL
18	37422	4.00	TERM,SOLDER SPLICE,20-10 AWG
19	37426	1.00	TERM,PUSH-ON,JUMPER,.25,16-14G
20	70953	4.00	CONN,MALE TERMINAL
21	71060	2.12	LOOM,SPLIT,CONVOLUTED,.250
22	71065	9.33	WIRE,14 GA,RED
23	71870	9.00	LOOM,SPLIT,CONVOLUTED,.750
24	72719	1.00	CONNECTOR,5 WAY,FEMALE
25	72720	5.00	TERM,PUSH ON,FEMALE,STRAIGHT
26	72749	1.00	CONNECTOR,5 WAY,MALE
27	851390204	2.00	TERM,RING,16-14 GA,#10 STUD
28	72753	1.00	RESISTOR,3K OHM,1 WATT
<b>GROUP 3</b>			

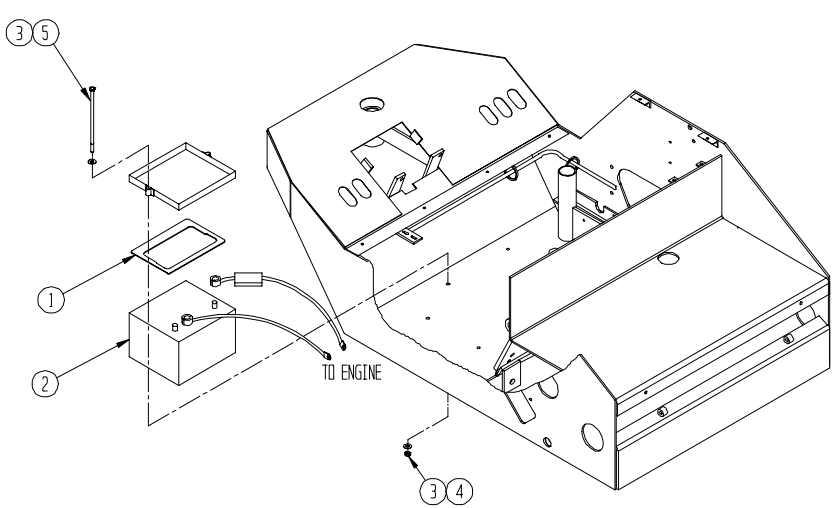

ITEM	PART NUMBER	QTY	DESCRIPTION
	<b>55089</b>	<b>REV. A1</b>	<b>FINAL ASSEMBLY,KOHLER</b>
1	004684102	4.67	STRIP,ABRASIVE,4"X60'ROLL,BLK
2	33163	1.00	CLAMP,HOSE,.50-.91,WORM,#08
3	33630-1	2.16	STRIPPING,.125
4	34976	2.00	DECAL,DELUXE
5	35244	1.67	STRIP,ADH SPONGE,.75X.062
6	36151	1.00	FILLER,TANK,4 IN
7	36195	1.00	DECAL SET,CONTROL
8	36346	1.00	DECAL,DRIVE CHAIN INSTRUCTION
9	37243	1.00	DECAL,WARNING,ENGINE EXHAUST
10	53053	1.00	SERIAL NUMBER PLATE,DELUXE
11	54607	2.00	DECAL,ROLLPAC III
12	54608	7.50	STRIPE,BLACK,2.50
13	54960	2.00	STRAP,DELUXE WATER TANK
14	6352	.50	HOSE,08,PUSH-ON,250
15	6576	1.00	SEAT,BLACK W/ROSCO LOGO
16	70319	1.00	FITT,90 08MP-08HB,POLY
17	71077	1.00	CAP,ST WL,REF 6436
18	72627	1.00	DECAL,WARNING,BATTERY INJURY
19	72670	1.00	TANK,WATER,DELUXE,35 GALLON
20	72676	1.00	DECAL,CAUTION,CLOSE FUEL VALVE
21	72677	1.00	DECAL,GASOLINE
22	72678	1.00	DECAL,WATER ONLY
23	72679	1.00	DECAL,CAUTION,15 PERCENT GRADE
24	72680	1.00	DECAL,STARTING INSTRUCTIONS
25	72681	1.00	DECAL,WARNING,READ OPR MANUAL
26	72682	1.00	DECAL,WARNING,ENGINE COVERS
27	72683	1.00	DECAL,WARNING,LEVER MOVEMENT
28	72686	1.00	DECAL,WATER CONTROL VALVE
29	72687	1.00	DECAL,HYDRAULIC WARRANTY VOID
30	80142	6.00	WASHER,TYPE A PLAIN,.375
31	80144	1.00	WASHER,TYPE A PLAIN,.500
32	80164	1.00	WASHER,SPLIT LOCK,.500
33	80224	2.00	CSHH,.375-16X1.25,GR5
34	80248	1.00	CSHH,.500-13X1.00,GR5
35	80352	4.00	NUT,FLEXLOC,.375-16,FULL,LT
36	81165	2.00	TACK,DIA .109X.020 GRIP LENGTH
38	37684	1.00	DECAL,HYD OIL,FILL TO SCREEN
39	D48	2.00	DECAL,ROSCO LOGO,SMALL,BLACK
40	D52	1.00	DECAL,PARKING BRAKE
41	R135	1.00	RUBBER GRIP
42	72701	1.00	DECAL,FUEL,STRAIGHT GASOLINE
NS	72755	2.00	DECAL,NO FORKLIFTS
<b>GROUP 3</b>			

ITEM	PART NUMBER	QTY	DESCRIPTION
	<b>54927-1</b>	<b>REV 0</b>	<b>DECAL KIT - HONDA ONLY (NO ILLUSTRATION)</b>
NS	004684102	4.67'	STRIP,ABRASIVE,4"X60'ROLL,BLK
NS	33630-1	1.50'	STRIPPING,.125
NS	34976	2	DECAL,DELUXE
NS	35244	1.67'	STRIP,ADH SPONGE,.75X.062
NS	36195	1	DECAL SET,CONTROL
NS	36346	1	DECAL,DRIVE CHAIN INSTRUCTION
NS	37243	1	DECAL,WARNING,ENGINE EXHAUST
NS	54607	2	DECAL,ROLLPAC III
NS	54608	7.50'	BLACK STRIPE,2.50
NS	72627	1	DECAL,WARNING,BATTERY INJURY
NS	72676	1	DECAL,CAUTION,CLOSE FUEL VALVE
NS	72677	1	DECAL,GASOLINE
NS	72678	1	DECAL,WATER ONLY
NS	72679	1	DECAL,CAUTION,15 PERCENT GRADE
NS	72680	1	DECAL,STARTING INSTRUCTIONS
NS	72681	1	DECAL,WARNING,READ OPR MANUAL
NS	72682	1	DECAL,WARNING,ENGINE COVERS
NS	72683	1	DECAL,WARNING,LEVER MOVEMENT
NS	72686	1	DECAL,WATER CONTROL VALVE
NS	72687	1	DECAL,HYDRAULIC WARRANTY VOID
NS	D34	1	DECAL,HYDRAULIC FLUID
NS	D48	2	DECAL,ROSCO LOGO,SMALL,BLACK
NS	D52	1	DECAL,PARKING BRAKE
NS	R135	1	RUBBER GRIP
NS	72701	1	DECAL,FUEL,STRAIGHT GASOLINE
	<b>54983</b>	<b>REV 0</b>	<b>SERVICE KIT - OPTION <u>HONDA ONLY</u> (NO ILLUSTRATION)</b>
NS	37278-04	4	FILTER,ELEMENT
NS	37440-01	1	MANUAL,PARTS,D/L III
NS	X198	1	COCO MAT 4X28
NS	X199	1	COCO MAT 4X34
NS	X260	4	ELEMENT
			<b>GROUP 4</b>

ITEM	PART NUMBER	QTY	DESCRIPTION
NS	53545	REV A	<b>BACKUP ALARM GROUP - OPTION (NO ILLUSTRATION)</b>
NS	33963	1	ALARM, BACKUP
NS	33964	1	SWITCH, BACKUP ALARM
NS	53544	1	BRACKET, BACKUP ALARM SWITCH
NS	54757	1	BRACKET, BACK UP ALARM
NS	956011180	1	<b>SIGN, SMV, METAL - OPTION (NO ILLUSTRATION)</b>
NS	54875	1	<b>TRAILER, DELUXE W/O BRAKES - OPTION (NO ILLUSTRATION)</b>
1	55054	REV. Ø	<b>GROUP, BATTERY, SHORT, D/L III - OPTION (SHOWN BELOW)</b>
2	55046	1.00	HOLDER, BATTERY CLAMP
3	72736	1.00	BATTERY, 12V, GROUP 58, 550 CCA
4	80142	4.00	WASHER, TYPE A PLAIN, .375
5	80352	2.00	NUT, FLEXLOC, .375-16, FULL, LT
5	80399	2.00	CSHH, .375-16X7.50, GR5
			
<b>GROUP 4</b>			

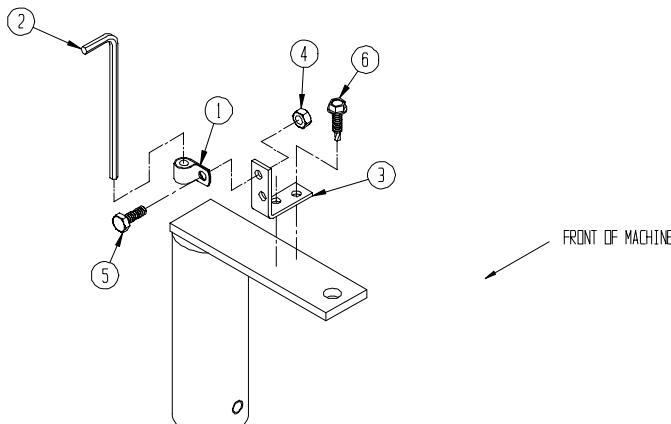
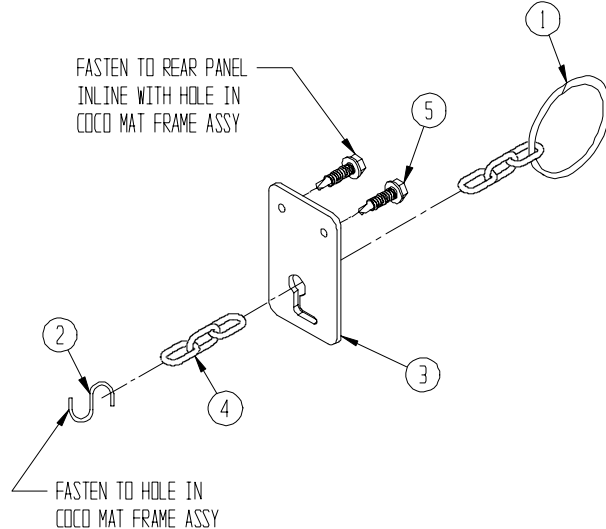
ITEM	PART NUMBER	QTY	DESCRIPTION
<p><b>55047</b>      <b>REV. Ø</b>      <b>GROUP, BYPASS VALVE WRENCH - OPTION (SEE BELOW)</b></p> <p>1      33594      1.00      CLAMP, LOOP, .25 OD, REM CUSHION</p> <p>2      72732      1.00      WRENCH, ALLEN, .1875, LONG ARM</p> <p>3      72740      1.00      BRACE, CORNER, 1.50X.625, ZINC</p> <p>4      80036      1.00      NUT, HEX, .250-20</p> <p>5      80192      1.00      CSHH, .250-20X.75, GR5</p> <p>6      80909      2.00      SCR, SLFDRL, HH, .250-14X1.00</p> 			
<p><b>55048</b>      <b>REV. Ø</b>      <b>GROUP, COCO MAT CHAIN UP - OPTION (SEE BELOW)</b></p> <p>1      37187      1.00      RING, SPLIT, 2.02IDX.18, ZINC CTD</p> <p>2      37371      1.00      HOOK, S, .120 WIRE, .50 EYE, 1.74 LG</p> <p>3      55049      1.00      HOLDER, COCO MAT CHAIN</p> <p>4      72739      1.00      CHAIN, STR LINK MACH, .120, NO 4</p> <p>5      80909      2.00      SCR, SLFDRL, HH, .250-14X1.00</p> 			



**GROUP 4**

# DELUXE ROLLPAC III ALPHABETICAL PARTS INDEX

\*\*\* Main headings appear in bold print \*\*\*

## A

ALARM,BACKUP 34  
ANCHOR,EMERGENCY BRAKE HANDLE 6, 27  
ANTI VIBRATION PAD 4, 26  
ARM ASSY 20  
AXLE REAR 6  
AXLE,REAR,1.25X38,DELUXE,50148 28

## B

BACKUP ALARM GROUP 34  
BALL 24  
BALL GUIDE CLAMP 24  
BALL NUT 24  
BAR,POST CLAMP 2, 28  
BATTERY BOOT,POS 2, 26  
BATTERY,12 VOLT,325 CCA 2  
BATTERY,12V,325 CCA 28  
BATTERY,12V,GROUP 58, 550 CCA 34  
BEARING CUP 24  
BEARING RACE 24  
BEARING,COLUMN 24  
BEARING,FLANGE,1.250 6, 28  
BLACK STRIPE,2.50 33  
BRACE,CORNER,1.50X.625,ZINC 35  
BRACKET,BACK UP ALARM 34  
BRACKET,BACKUP ALARM SWITCH 34  
BRAKE ASSY 6, 28  
BRAKE PADS 6, 28  
BRKT,ENGINE LIFT,HONDA,13HP 8  
BUSHING,SECTOR SHAFT 24

## C

CABLE,BATTERY,NEG,14,4GA,.406 2, 28  
CABLE,BATTERY,POS,4GAX14 2, 26  
CABLE,T HANDLE 2, 26  
CABLE,THROTTLE,3.00 TRAVELX70 2, 26  
CAP,ST WL 2  
CAP,ST WL,REF 6436 12, 32  
CHAIN,STR LINK MACH,.120,NO 4 35  
CHAIN,W/CONN & OFFSET LINK 6, 26  
CLAMP,HOSE,.44-.78,WORM,#06 8, 29  
CLAMP,HOSE,.50-.91,WORM,#08 4, 8, 12, 16, 20, 26, 29, 32  
CLAMP,JACKET 24  
CLAMP,LOOP,.25 OD,REM CUSHION 35  
CLAMP,LOOP,.50 OD PLSTC COVER 2, 4, 27  
CLAMP,LOOP,.75 OD,PLSTC COVER 8, 16, 20  
CLAMP,MUFFLER,1.5 29  
CLEVIS,#4 YOKE,.375-24,W/#34PIN 22

COCO MAT 4X28 20, 33  
COCO MAT 4X34 16, 33  
COCO MAT FRAME ASSY,REAR 16  
COCO MAT GROUP 16, 20  
COCO MAT GROUP,DELUXE 2, 26  
COLLAR PLATE,DELUXE,AXLE W/M 18  
CONE 18  
CONN,BULLET,.156 STD,16-14 GA 10  
CONNECTOR,5 WAY,FEMALE 10, 30  
CONNECTOR,5 WAY,MALE 30  
CONN,LINE,.156 STD,22-18 GA 10  
CONN,MALE TERMINAL 30  
COOLER,OIL 4, 28  
COTTER PIN,.125X.75 6, 27  
COTTER PIN,.188X1.00 16, 20  
COTTER PIN,.188X2.00 20  
COTTER PIN,.25X2.00 18  
COVER,FRONT,W/M 2  
COVER,STEERING COLUMN 2  
COVER,STEERING CONSOLE,DELUXE 28  
COVER,TOP 4  
COVER,TOP,KOHLER 15 26  
CPLG,FLEX,MODEL 300,.75 BORE 8, 29  
CPLG,FLEX,MODEL 300,1.00 BORE 8, 29  
CPLG,INSERT,HYTREL 370H 8, 29  
CRG BOLT,.375-16X1.00,GR5 22  
CSHH,.250-20X.75,GR5 4, 8, 29, 35  
CSHH,.250-20X1.00,GR5 4, 28  
CSHH,.250-20X1.25,GR5 4  
CSHH,.312-18X.50,GR5 22  
CSHH,.312-18X.75,GR5 2, 4, 27  
CSHH,.312-18X1.00,GR5 16, 20, 22  
CSHH,.312-18X1.25,GR5 22  
CSHH,.312-18X3.00,GR5 2, 27  
CSHH,.375-16X1.00,GR5 4, 27  
CSHH,.375-16X1.25,GR5 4, 6, 8, 12, 27, 29, 32  
CSHH,.375-16X1.50,GR5 16  
CSHH,.375-16X1.50,GR5 20  
CSHH,.375-16X1.75,GR5 4, 6, 27  
CSHH,.375-16X2.25,GR5 6, 27  
CSHH,.375-16X7.50,GR5 34  
CSHH,.375-16X9.50,GR5 2, 27  
CSHH,.500-13X1.00,GR5 12, 32  
CSHH,.500-13X1.25,GR5 6, 27  
CSHH,.500-13X1.50,GR5 2, 26  
CSHH,.500-13X1.75,GR5 2, 18  
CSHH,.500-13X2.00,GR5 4, 27  
CSHH,.500-13X2.25,GR5 4, 28  
CSHH,.500-13X2.75,GR5 22  
CSHH,.500-20X1.25,GR5 6, 28  
CSHH,.500-20X2.25,GR5 6, 27  
CSSH,.500-13X1.75 8, 29

# DELUXE ROLLPAC III ALPHABETICAL PARTS INDEX

\*\*\* Main headings appear in bold print \*\*\*

## D

DECAL KIT - HONDA ONLY 33  
DECAL SET,CONTROL 14, 32, 33  
DECAL,CAUTION,15 PERCENT GRADE 14, 32, 33  
DECAL,CAUTION,CLOSE FUEL VALVE 14, 32, 33  
DECAL,DELUXE 12, 14, 32, 33  
DECAL,DRIVE CHAIN INSTRUCTION 14, 32, 33  
DECAL,FUEL,STRAIGHT GASOLINE 14, 32, 33  
DECAL,GASOLINE 14, 32, 33  
DECAL,HYD OIL,FILL TO SCREEN 12, 32  
DECAL,HYDRAULIC FLUID 33  
DECAL,HYDRAULIC WARRANTY VOID 14, 32, 33  
DECAL,NO FORKLIFTS 32  
DECAL,PARKING BRAKE 14, 32, 33  
DECAL,ROLLPAC III 12, 14, 32, 33  
DECAL,ROSCO LOGO,SMALL,BLACK 12, 14, 32, 33  
DECAL,STARTING INSTRUCTIONS 12, 32, 33  
DECAL,WARNING,BATTERY INJURY 14, 32, 33  
DECAL,WARNING,ENGINE COVERS 14, 32, 33  
DECAL,WARNING,ENGINE EXHAUST 14, 32, 33  
DECAL,WARNING,LEVER MOVEMENT 14, 32, 33  
DECAL,WARNING,READ OPR MANUAL 12, 32, 33  
DECAL,WATER CONTROL VALVE 12, 32, 33  
DECAL,WATER ONLY 12, 32, 33  
DISC,BRAKE,DELUXE 6, 27  
DRUM/YOKE ASSY,FRONT 2, 26  
DRUM,REAR,D/L III,51842 28  
DRUM,REAR,DELUXE III 6

## E

ELEMENT 33  
ENGINE ASSEMBLY, HONDA 8  
ENGINE ASSEMBLY, KOHLER 29, 30  
ENGINE ASSY,D/L III,KOHLER 15 26  
ENGINE WIRE HARNESS, KOHLER 30  
ENGINE,HONDA,13 HP,GAS 8  
ENGINE,KOHLER,15 HP,GASOLINE 29  
EXHAUST TUBE W/M,DELUXE 8

## F

FACE,STEERING CONSOLE,DELUXE 26  
FILLER,BREATHER,-3 SCREEN 8, 29  
FILLER,TANK,4 IN 12, 32  
FILTER ASSY 8, 29  
FILTER ONLY 8, 29  
FILTER,ELEMENT 33  
FINAL ASSEMBLY, HONDA 12, 14  
FINAL ASSEMBLY,KOHLER 32  
FITT,45 08MJ-08MB 8, 29  
FITT,45 10MJ-08MB 8, 29

FITT,90 06MB-06HB 8  
FITT,90 06MJ-04MB 4, 26  
FITT,90 06MJ-04MP 4, 28  
FITT,90 06MJ-06MP 8, 29  
FITT,90 08MB-12FPX 8, 29  
FITT,90 08MP-08HB,CRIMPED 8, 29  
FITT,90 08MP-08HB,POLY 4, 12, 26, 32  
FITT,90 10MJ-10FJX 4, 28  
FITT,90 10MJ-10MB 4, 26  
FITT,90 12MJ-12MP 8, 29  
FITT,90-LL 06MJ-04MP 4, 26  
FITT,90,08MP-08HB,POLY 16  
FITT,LUBE,STR,02FP 22  
FITT,LUBE,STR,1/4-28 18  
FITT,PLUG 02PD,DUST 8, 29  
FITT,STR 02MP-02FP 8  
FITT,STR 06FJX-06HB,PUSH-ON 8, 29  
FITT,STR 06MB-06HB 29  
FITT,STR 08FJX-08HB,PUSH-ON 8, 29  
FITT,STR 08MP-08HB,BLK POLY 4, 20, 26  
FITT,STR 10MJ-10MB 4, 28  
FITT,STR 12FJX-12HB,PUSH-ON 8, 29  
FITT,STR 12MP-12HB,BRASS 8, 29  
FITT,TEST 02FP-02PD 29  
FITT,TEST 02MP-02PD 8  
FITT,TEST 04MB-02PD 8, 29  
FOOT MOUNT W/M 4, 26  
FRAME ASSY 20  
FRAME W/M,DELUXE,HONDA,13 HP 2, 26  
FRONT DRUM - DELUXE III 18  
FRONT DRUM/YOKE ASSEMBLY 18  
FRONT SCRAPER BAR 20  
FUSE HOLDER,IN-LINE,BLADE,SEAL 10, 30  
FUSE,BLADE,10AMP,ATC-10 10, 30

## G

GASKET 24  
GASKET,EXHAUST,KOHLER 15 30  
GAUGE,HOUR METER,INHIBITED 2, 28  
GEAR,SAGINAW STEERING 2, 26  
GREASE BOLT ASSY 18  
GROUP,BYPASS VALVE WRENCH 35  
GROUP,BATTERY,SHORT,D/L III 34  
GROUP,COCO MAT CHAIN UP 35

## H

HAIR PIN COTTER,#11,.125 DIA 26  
HANDLE EXT W/M 4, 26  
HARNESS,WIRE,D/L III,KOHLER 15 26  
HARNESS,WIRE,HONDA 13HP,DELUXE 2

# DELUXE ROLLPAC III ALPHABETICAL PARTS INDEX

\*\*\* Main headings appear in bold print \*\*\*

HOLD DOWN,BATTERY 2, 28  
HOLDER,BATTERY CLAMP 34  
HOLDER,COCO MAT CHAIN 35  
HOOK,S,.120 WIRE,.50 EYE,1.74 LG 35  
HORN GROUP 2, 6, 26, 28  
HOSE ASSY 3000 PSI,-03 X 22 22  
HOSE,06,PUSH-ON,250,BLUE 8, 29  
HOSE,08,PUSH-ON,250 4, 8, 12, 26, 29, 32  
HOSE,08X34,10FJX(2),3500 8, 29  
HOSE,12,HYD,300 8, 29  
HOUSING 24  
HOUSING SLIDE COVER & BUSHING 24  
HYD TANK W/M,ROLLER 8, 29  
HYDRAULIC SPECIFICATIONS 8, 29

## **J**

JACKET 24

## **K**

KEY,SQ,.250X.875 8, 29  
KIT,BALL GUIDE 24  
KIT,HORN 6, 28  
KIT,MUFFLER,KOHLER 15 30

## **L**

LASH ADJUSTER 24  
LEVER,BRAKE 6, 28  
LEVER,RH DIR CONTROL,DELUXE 22  
LOCKNUT,ADJUSTER 24  
LOOM,SPLIT,CONVOLUTED,.250 10, 30  
LOOM,SPLIT,CONVOLUTED,.500 10  
LOOM,SPLIT,CONVOLUTED,.750 30  
LOOM,,SPRIAL CUT,.25 OD,NATURAL 6, 28

## **M**

MACH SCR,#6-32X1.25 22  
MACH SRC,PH,#8-32X.50 8  
MAIN ASSEMBLY, HONDA 2, 4, 6  
MAIN ASSEMBLY, KOHLER 26, 27, 28  
MANUAL,PARTS,D/L III 33  
MOTOR,HYD 4, 28  
MOUNT W/M,CONTROL LEVER 22  
MOUNT,LOWER,MUFFLER 30  
MOUNT,PUMP 8, 29  
MOUNT,UPPER,MUFFLER 30

## **N**

NUT,FLEXLOC,.250-20,FULL,LT 4, 27  
NUT,FLEXLOC,.312-18,FULL,LT 2, 16, 20, 22, 27

NUT,FLEXLOC,.375-  
16,FULL,LT 2, 4, 6, 12, 16, 20, 22, 27, 32, 34  
NUT,FLEXLOC,.375-24,THIN,LT 22  
NUT,FLEXLOC,.500-13,FULL,LT 2, 4, 18, 22, 27  
NUT,HEX,#6-32 22  
NUT,HEX,#8-32 8  
NUT,HEX,.250-20 35  
NUT,HEX,JAM,.312-18 6, 22, 26  
NUT,HEX,JAM,.375-16 6, 26  
NUT,HEX,JAM,.375-24 22  
NUT,HEX,JAM,.375-24,LH 22  
NUT,HEX,JAM,.500-13 4, 27  
NUT,HEX,JAM,.750-16 2, 27

## **O**

OIL,HYDRAULIC,MULTI SERVICE 27  
OIL,SAE 10W40 CC/CD 27

## **P**

PIN,CLEVIS,.250X.750 6, 27  
PIN,COTTER,.094X.750 6, 26  
PIN,KING W/M 18  
PIN,W/M PIVOT 18  
PIPE,90,02MP-02FP,MI 22  
PIPE,NIPPLE,02X3.00,300# 29  
PIPE,NIPPLE,08XCLOSE 4, 27  
PIPE,TEE,08FP,MI 4, 27  
PITMAN ARM,REWORKED 2, 26  
PITMAN LOCKWASHER 24  
PITMAN NUT 24  
PITMAN SEAL 24  
PIVOT CAP,FRONT 2, 28  
PULL BAR ASSY 6, 27  
PUMP TUBE W/M,DELUXE 22  
PUMP,RH 1000PSI 8, 29

## **R**

RESISTOR,3K OHM,1 WATT 30  
RH CONTROL LEVER ASSY,DELUXE 26  
RING,HOG 16, 20  
RING,SPLIT,2.02IDX.18,ZINC CTD 35  
ROD END,SPHER,.750-16 2, 26  
ROD END,SPHER,FEM,.375-24 LH 22  
ROD,EMERGENCY BRAKE HANDLE 6, 26  
ROD,PUMP CONTROL,51353 22  
ROD,SCRAPER 20  
ROD,SCRAPER BAR,.625X21.63 16  
ROD,STEERING 2, 28  
RUBBER GRIP 12, 22, 32, 33

# DELUXE ROLLPAC III ALPHABETICAL PARTS INDEX

\*\*\* Main headings appear in bold print \*\*\*

## S

SCRAPER BAR ASSY,REAR 16  
SCRAPER GROUP,DELUXE,HONDA 2, 26  
SCREEN,OIL COOLER COVER 28  
SCREW,CLAMP BALL GUIDE 24  
SCR,SLFDDRL,HH,.250-14X1.00 35  
SCR,SLFDRL,HH,.250-14X1.00 28, 35  
SCR,SLFORL,HH,.250-14X1.00 2  
SEAT POST,INNER 4, 28  
SEAT,BLACK W/ROSCO LOGO 12, 32  
SEAT,STEERING 24  
SECTOR AND SHAFT 24  
SERIAL NUMBER PLATE,DELUXE 12, 32  
SERVICE KIT - OPTION HONDA ONLY 33  
SET S.SQ,.500-13X3.5 4  
SET SCREW DOG POINT 22  
SET S,HSKT,KCUP,.375-16X.375 18, 22  
SET S,SQ,.500-13X3 1/2 26  
SHIM KIT,LASH ADJUSTER 24  
SIDE LH 4  
SIGN, SMV, METAL 34  
SLAT,SPRING 4, 28  
SPACER BAR,STEERING POST CLAMP 2, 26  
SPACER,2.50 ODX1.562 IDX.029 T 18  
SPACER,2.50 ODX1.562 IDX.048 T 18  
SPACER,2.50 ODX1.562 IDX.134 T 18  
SPACER,2.50 ODX1.562 IDX.250 T 18  
SPACER,BRAKE,DELUXE 6, 26  
SPRAY BAR ASSY 20  
SPRAYBAR ASSY,REAR,DELUXE 16  
SPRING 22  
SPRING,LH 20  
SPRING,RH 20  
SPRING,SCRAPER BAR 4, 16, 27  
SPRING,STEERING SHAFT 24  
SPROCKET 6, 28  
SPROCKET,REWORK 4, 27  
STAY,CHOKE CONTROL,FOR CABLE 8  
STEEL SCRAPER GROUP - FRONT 20  
STEEL SCRAPER GROUP - REAR 16  
STEERING GEAR 24  
STRAP,DELUXE WATER TANK 12, 32  
STRIP,ABRASIVE,4"X60"ROLL,BLK 14, 32, 33  
STRIP,ADH SPONGE,.75X.062 14, 32, 33  
STRIPE,BLACK,2.50 12, 14, 32  
STRIP,EXHAUST TUBE SUPPORT 4  
STRIPPING,.125 14, 32, 33  
SWITCH,IGNITION,6 TERM,3 POS 2  
SWITCH,BACKUP ALARM 34  
SWITCH,SNAP ACTING,W/ROLLER 22  
SWITCH,STARTER PUSH BUTTON 6, 28

## T

TAB W/M,FRONT FACE 2  
TACK,DIA .109X.020 GRIP LENGTH 12, 32  
TANK,WATER,DELUXE,35 GALLON 12, 32  
TERM,BULLET,.156 STD,16-14 GA 6, 28, 30  
TERM,PUSH ON,FEMALE,STRAIGHT 10, 30  
TERM,PUSH-ON,.25,FEM,16-14 GA 6, 28  
TERM,PUSH-ON,.25,FEM,18-14,SLV 10, 30  
TERM,PUSH-ON,.25,M,18-14,SLV 30  
TERM,PUSH-ON,.25,MALE,16-14GA 10, 30  
TERM,PUSH-ON,JUMPER,.25,16-14G 28, 30  
TERM,RING,16-14 GA, #10 STUD 6, 28  
TERM,RING,16-14 GA,#10 STUD 10, 30  
TERM,RING,16-14 GA,.250 STUD 10  
TERM,RING,16-14 GA,.312 STUD 30  
TERM,SOLDER SPLICE,20-10 AWG 10, 30  
THRUST BEARING,2.00X3.00X.25 2, 26  
TRAILER,DELUXE W/O BRAKES 34  
TRANSMISSION CONTROL LEVER ASSEMBLY 22  
TRIM, RUBBER,PUSH ON 2  
TRIM,RUBBER,PUSH ON 28  
TUBE,FLEX,EXH,1.50 ID,13.00 LG 30  
TUBE,RND,1.00X.216X.875,SMLS 6, 27

## U

U-BOLT,.250-20,1.12IW,2.00IL 4, 26

## V

VALVE HANDLE REWORK,.5 BALL 4, 26

## W

W/M,EXH FLANGE,45,KOHLER 15 30  
W/M,EXH FLANGE,KOHLER 15 30  
W/M,FRONT COVER,KOHLER 15 26  
WASHER,DISC LOCK,.500 18  
WASHER,FLAT,1.50X1.031X.062 18  
WASHER,FLAT,1.50X1.031X.075 18  
WASHER,FLAT,1.50X1.031X.125 18  
WASHER,NYLON,2.125 OD 22  
WASHER,SAE PLAIN,.625 18  
WASHER,SAE PLAIN,1.250 6, 27  
WASHER,SAE,HARDENED,.375 4, 28  
WASHER,SAE,HARDENED,.750 2  
WASHER,SPLIT LOCK,.250 2, 8, 29  
WASHER,SPLIT LOCK,.312 2, 4, 6  
WASHER,SPLIT LOCK,.375 6, 8, 22, 29  
WASHER,SPLIT LOCK,.500 2, 6, 8, 12, 29, 32  
WASHER,SPLIT LOCK,.625 18  
WASHER,TYPE A PLAIN,#8 8, 22

# DELUXE ROLLPAC III ALPHABETICAL PARTS INDEX

\*\*\* Main headings appear in bold print \*\*\*

WASHER,TYPE A PLAIN,.250 4, 8, 29  
WASHER,TYPE A PLAIN,.312 2, 4, 6, 22  
WASHER,TYPE A  
    PLAIN,.375 2, 4, 6, 8, 12, 20, 22, 29, 32, 34  
WASHER,TYPE A PLAIN,.500 4, 12, 18, 22, 32  
WASHER,TYPE A PLAIN,.625 16, 20  
WHEEL,STEERING,17.00 OD 2, 4, 26  
WIRE HARNESS, HONDA 10  
WIRE,14 GA,RED 30  
WIRE,14 GA,WHITE 10  
WIRE,16 GA,BLACK 6, 10, 28  
WIRE,16 GA,BLACK/YELLOW STRIPE 10, 30  
WIRE,16 GA,BLUE 30  
WIRE,16 GA,BROWN 10, 30  
WIRE,16 GA,GREEN 10, 30  
WIRE,16 GA,ORANGE 10, 30  
WIRE,16 GA,PINK 30  
WIRE,16 GA,PURPLE 30  
WIRE,16 GA,RED 10  
WIRE,16 GA,RED/BLACK STRIPE 10, 30  
WIRE,16 GA,WHITE 30  
WIRE,16 GA,WHITE/BLACK STRIPE 10  
WIRE,16 GA,YELLOW 10, 30  
WIRE,16 GA,YELLOW/RED STRIPE 10  
WORM BEARING ADJUSTER 24  
WORM SEAL 24  
WORM SHAFT 24  
WORM SHAFT & BALL NUT ASSEMBLY 24  
WRENCH,ALLEN,.1875, LONG ARM 35

## **Y**

YOKE W/M FRONT DELUXE 18  
YOKE,FRONT,AXLE 30.00 18