Operation & Maintenance Manual

STRETCH 16 & 18 SCREED

**Fuel Burner and Electric
Heat Models**



To the Owner & Operator:

We have tried to provide information that gives our customers a clear understanding of equipment construction, function, capabilities and requirements. This information is based on the knowledge and experience of qualified people at our company and in our field organization. Proper use of this information rewards users of our equipment with high efficiency, maximum service life and low maintenance costs. That is why we strongly recommend that anyone using our equipment be familiar with this manual.

Information presented here should not be considered authoritative in every situation. Users will as a matter of course encounter problems and circumstances that raise questions not anticipated here. Such questions should be directed to their distributor or the factory.

Anyone who uses this equipment for any purpose other than that for which it was intended assumes sole responsibility for dangers encountered and injuries sustained as a result of such misuse.

⚠ DANGER

Federal, state and local safety regulations aim to protect both people and property from accident, injury and harmful exposure. When complied with, such regulations are often effective. Hazards to personnel and property are further reduced when this equipment is used in accordance with all operation and maintenance instructions. Generally:

- (1) Read and heed all danger, warning, caution, and notice decals. Know what guards and protective devices are included and see that each is installed and in operational condition. Additional guards and protective devices may be required and must be installed by the user (owner) before operating.
- (2) Never attempt to maintain, lubricate or adjust this equipment while it is running. Lock out and tag out all energy sources before doing maintenance, cleaning, adjusting or repairing this equipment. Make it impossible for anyone to start this machine while others are working on it or in it.
- (3) Wear personal protective equipment such as hard hats, ear plugs, safety glasses and safety shoes when operating this equipment. Do not wear loose clothing or long hair.
- (4) Think safety and act safely. Stay alert at all times. Eliminate or neutralize potential hazards as soon as you spot them. Never allow anyone to engage in horseplay when near this equipment.

⚠ DANGER

Failure to take these precautions will result in death or severe personal injury.

The following warning applies to equipment supplied with lead-acid batteries:

⚠ WARNING

Battery posts, terminals and related accessories contain lead and lead compounds, chemicals known to the State of California to cause cancer and reproductive harm.

Wash hands after handling.

Table of Contents

Section 1 - Introduction

About This Manual	1 - 1
-------------------------	-------

Section 2 - Safety

Introduction	2 - 1
Symbols and Standards	2 - 2
Safety Alert Symbol	2 - 2
Hazard Classification	2 - 2
Decals and Icons	2 - 3
Decal Locations - Stretch 16	2 - 4
Decal Locations - Stretch 18	2 - 5
Danger and Warning Decals	2 - 6
Personal Safety	2 - 7
Management Responsibilities	2 - 7
Operator Responsibilities	2 - 7
Work Area Safety	2 - 8
Equipment & Tools	2 - 8
What is Lockout & Tagout?	2 - 9
When is Lockout & Tagout required?	2 - 9
Who must apply a lock & tag?	2 - 9
When can a lock and tag be removed?	2 - 9
Who can remove a lock and tag?	2 - 9
Screed Safety Information	2 - 10
Training and Knowledge	2 - 10
Safe Paver Operation	2 - 10

Section 3 - Set Up and Operation

Receiving New Equipment	3 - 1
Pre-Operation Check	3 - 1
Principle Of Operation	3 - 2
Asphalt Flow	3 - 2
Equipment Description	3 - 3
Detailed Equipment Callouts	3 - 4
1) Main Screed Section	3 - 4
2) Pull Arm Mount	3 - 4
3) Slope Indicator	3 - 4
4a) Fuel Burner/Vibrator Control Panels	3 - 4
4b) Electric Screed Heat and Vibrator Control Panels	3 - 4
5) Depth Crank	3 - 4
6) Remote Screed Control	3 - 4
7) Vibrator	3 - 4
8) Match Height	3 - 4
9) Crown	3 - 4

Table of Contents

10) Walkways	3 - 4
11) Burners	3 - 4
12) Rear Extending Screed Sections	3 - 4
13) End Gates	3 - 5
Remote Controls	3 - 5
Supporting an Elevated Screed	3 - 6
Detaching Screed from Tractor	3 - 7
Preheating the Screed	3 - 8
Operating the Screed	3 - 9
Mat Thickness Control	3 - 9
Screed Pull Arms	3 - 10
Pull Point Cylinder Speed Test	3 - 10
Pull Point Position	3 - 11
Effects of Pull Points Positioned Too High	3 - 12
Effects of Pull Points Positioned Too Low	3 - 12
Correct Tow Point Position	3 - 12
Mat Crown Control	3 - 13
Screed Adjustments	3 - 13
General	3 - 13
Nulling the Screed	3 - 13
Screed Bottom Flatness	3 - 14
Fixed Strike-off	3 - 14
Lead/Tail Crown	3 - 14
Final Crown Adjustment	3 - 16
Match Height Adjustment	3 - 16
Independent Angle of Attack	3 - 16
Seal Plate	3 - 17
Extending Screed Alignment	3 - 17
Extending Screed Pre-torque	3 - 18
Adjusting Pre-Torque	3 - 18
Screed Accessories	3 - 20
Screed Heating Units	3 - 20
Screed Vibrators	3 - 20
Operating Screed Vibrator	3 - 20
Vibrator Weight Installation and Alignment	3 - 21
Strike-Offs	3 - 22
Adjusting Strike-Off	3 - 22
Extension Vibrator	3 - 22
Installing Screed Extensions	3 - 22
Crowning Mechanism Chain Tension	3 - 25
Changing Screed Bottom	3 - 25
Screed Bottom Removal	3 - 25
Screed Bottom Installation	3 - 26

Table of Contents

Cleaning Screed	3 - 27
Lubrication	3 - 28
General	3 - 28
Depth Cranks	3 - 28
Vibrator Bearings	3 - 28
Match Height	3 - 28
Extending Screed Slope	3 - 28
Crown	3 - 28
Section 4 - Fuel Burner Operation	
Overview	4 - 1
Summary of Burner Operations	4 - 1
Control Panel	4 - 2
Burner/Fuel/Vibrator Control Panel	4 - 2
Operating Screed Burners	4 - 3
Burner Shut-off Sequence	4 - 3
Burner Maintenance	4 - 4
Section 5 - Electric Screed Operation	
Overview	5 - 1
Stretch Electric Screed Controls	5 - 2
Control Panel Functions	5 - 3
Temperature Controllers	5 - 4
1) Temperature Controller Set Button	5 - 4
2) Temperature Up Button	5 - 4
3) Temperature Down Button	5 - 4
4) Temperature Controller Display	5 - 4
5) Temperature Controller Ready Light	5 - 4
6) Temperature Controller #2 Light	5 - 4
7) Temperature Controller #1 Light	5 - 4
Section Controllers	5 - 4
8) Screed Section Control Switch	5 - 4
9) Screed Section Heater Power Indicator	5 - 4
All-In-One Meter	5 - 5
10) All-In-One Meter Frequency	5 - 5
11) All-In-One Meter Voltage	5 - 5
12) All-In-One Meter Amperage	5 - 5
Circuit Breakers	5 - 5
13) Screed Control Panel Circuit Breaker	5 - 5

Table of Contents

Stretch Electric Screed Operation	5 - 5
Screed Generator Pump Set-Up	5 - 6
Start-up After Initial Installation of Pump	5 - 6
Set Pump Max Pressure	5 - 7
Set Pump Standby Pressure	5 - 7
Set Generator Motor Speed (Frequency)	5 - 7
Tractor Generator Plumbing	5 - 8
Attaching Screed To Tractor Generator Pump	5 - 8
Operating Tractor Pump Without Screed	5 - 8
 Appendix A - Schematics	
Hydraulic & Electrical Schematics	A - 1

About This Manual

Section 1 - Introduction

About This Manual

This book is an operation and maintenance manual for the owner or operator of the equipment described within.

We strongly recommend that anyone working with this equipment become familiar with the manual, whether or not you have experience with similar equipment.

This manual will help you understand how to install your equipment, prepare it for operation, and perform normal operation and maintenance tasks.

 DANGER

This manual contains information necessary for proper and safe operation. Carefully read this manual before attempting to operate. Failure to read and heed instructions preceded by a safety-alert symbol can cause death or severe personal injury as well as equipment and environmental damage.

Experience has shown it is to your advantage to keep a copy of this manual where operators can consult it as needed and to have a copy on file in your office, so that shift leaders or supervisors can conveniently refer to it. Additional copies can be ordered through your distributor.

This equipment is precisely engineered, highly functional, and heavy-duty designed to provide years of excellent service performing to customer specifications. We are proud to manufacture this equipment for your use and profit. We also take pride in the quality of our service and replacement parts.

This manual, however, is not a parts catalog and should not be used to order parts. Only your Parts Book, identified with your machine's serial number, is an authoritative source of part numbers and part descriptions for your equipment.

Ongoing improvement of product design may in the future result in changes to some parts. Use part numbers, model numbers and serial numbers from your Parts Book to communicate with your distributor.

About This Manual

Section 2 - Safety

Introduction

This equipment is designed expressly for hot mix paver operations. When our equipment is used for purposes other than those for which it was designed, user assumes sole responsibility for any injuries or damage that may result from said misuse. We emphatically recommend that this equipment be operated only by personnel who are trained in its use.

We make no guarantee, either expressly or by implication, that this equipment meets all local or federal safety regulations. It is the responsibility of those individuals who own and/or operate this machine to verify that all safety regulations are complied with before starting either this unit or any associated equipment.

Symbols and Standards

Symbols and Standards

Important symbols and hazard classification standards relating to safe equipment operation are used throughout this manual. Make sure you read, understand and follow all DANGER, WARNING and CAUTION decals on equipment.

Safety Alert Symbol

The safety alert symbol (Figure 2 - 1) is used to alert you to potential personal injury hazards. Obey all safety messages that follow this symbol to avoid possible injury or death.



Figure 2 - 1 Safety Alert Symbol

Hazard Classification

A multi-tier hazard classification system is used to communicate potential personal injury hazards. The following signal words used with the safety alert symbol indicate a specific level of severity of the potential hazard (Figure 2 - 2). Signal words used without the safety alert symbol relate to property damage and protection only. All are used as attention-getting devices throughout this manual as well as on decals and labels fixed to the machinery to assist in potential hazard recognition and prevention.

⚠ DANGER	DANGER indicates an imminently hazardous situation which, if not avoided, will result in death or serious injury.
⚠ WARNING	WARNING indicates a potentially hazardous situation which, if not avoided, could result in death or serious injury.
⚠ CAUTION	CAUTION indicates a potentially hazardous situation which, if not avoided, may result in minor or moderate injury.
CAUTION	CAUTION used without the safety alert symbol indicates a potentially hazardous situation which, if not avoided, may result in property damage.
NOTICE	NOTICE indicates information or a company policy that relates directly or indirectly to the safety or protection of property.

Figure 2 - 2 Hazard Classification

Symbols and Standards

Decals and Icons

Beneath all safety regulations lies a set of common-sense rules. Everyone who works with or near heavy equipment must be aware of those rules. To foster and maintain such an awareness in our customers, safety decals are fixed on our equipment.

Icons on our safety decals remind both workers and supervisors of common hazards and procedures that, in the course of a busy day, they might otherwise forget. The language of the icons is simple and direct (Figure 2 - 3).

	Place guards around all moving parts on this machine. Never start the machine if those guards are broken or missing.
	Keep hands, feet, clothes and hair away from moving belts and sheaves.
	Wear hearing protection when you're near this equipment.
	Wear respiratory protection when near this equipment. Rock dust is hard on your lungs.
	Rock chips sometimes come flying out of equipment. Wear goggles or safety glasses near this equipment.
	Head injury is a hazard around any heavy equipment. Wear your hard hat.
	Lockout & Tagout. Equipment may be energized. Lockout and tagout all energy sources prior to performing maintenance or adjustments.
	Electrocution Hazard. Will cause death, burns and involuntary muscle control. De-energize equipment prior to entry. Entry by authorized trained personnel only. Ground all equipment per all Federal, state, or local electrical codes. Use insulated rubber gloves or other protective equipment.
	Read all the manuals that shipped with your equipment. Maintenance is done more easily and safely when you know what you're doing.

Figure 2 - 3 Safety Pictograms Explained

Decal Locations - Stretch 18

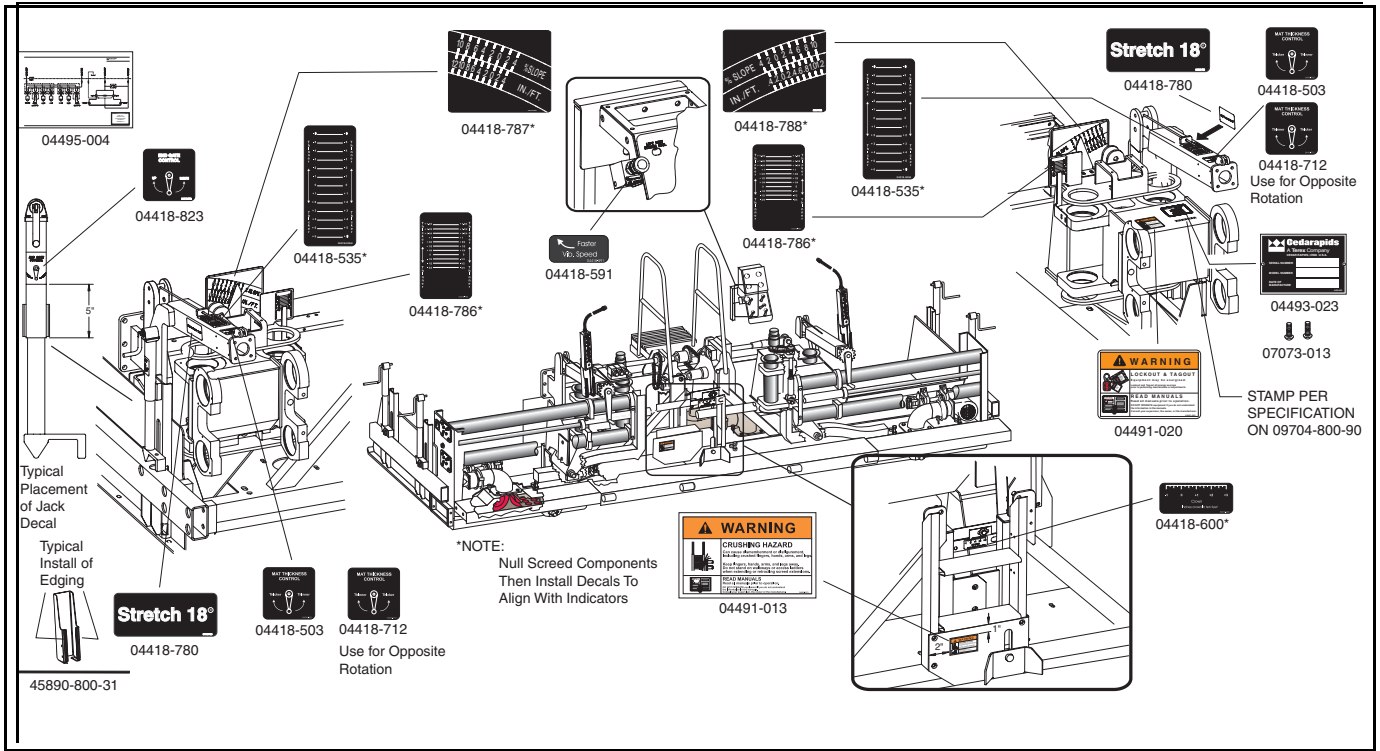

Figure 2 - 6 Decal Locations on Stretch 18 - All Models

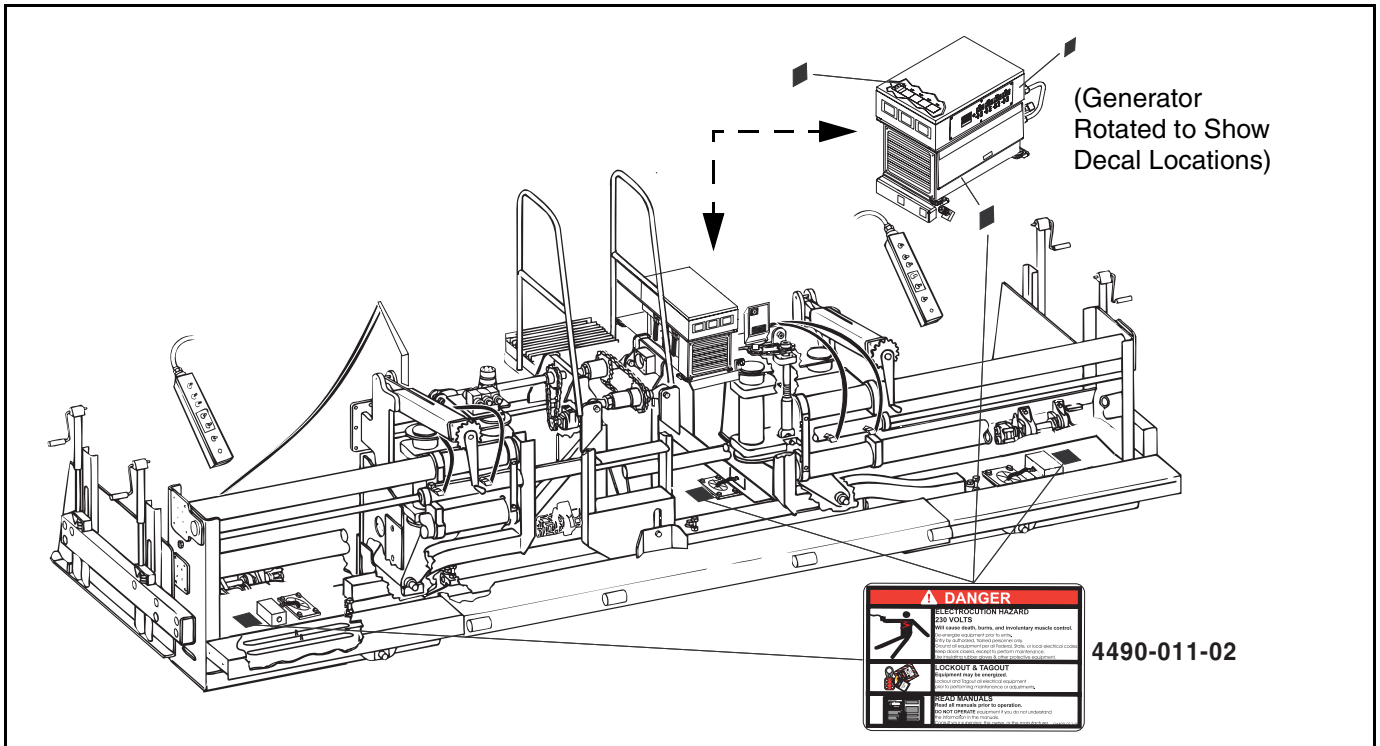

Figure 2 - 7 Additional DANGER! Decal Locations Found on Stretch 18 Models with Electric Screed

Symbols and Standards

Danger and Warning Decals



Figure 2 - 8 Screed Danger and Warning Decals

Personal Safety

Personal Safety

This equipment is designed with the safety of all personnel in mind. Never attempt to change, modify, eliminate or bypass any of the safety devices installed at the factory. Guards, covers and shields installed around moving parts at the factory are meant to prevent accidental injury to operators and other personnel. **Do not remove them.**



Sometimes, at a customer's request, equipment is shipped without certain features such as a drive sheave. When this occurs, we attach a warning decal to alert installers that the related guard or other safety feature is missing. In such cases it is the customer's responsibility to guard the machine properly.

We recommend the following basic safety practices:

Management Responsibilities

- Make sure that everyone working on or near this equipment is familiar with safety precautions. Have a supervisor at the job site responsible for job safety.
- Give crew members specific safety responsibilities and instruct them to report any unsafe conditions to their supervisor

Operator Responsibilities

- Read all danger, warning, caution and notice signs.

- Always lock out and tag out involved energy sources before performing maintenance or adjustments on this equipment. Make it impossible for anyone to start this machine while others work on it or in it.
- Never remove any guard, cover or shield when this equipment is in motion.
- Replace guards, covers and shields when the task for which you removed them is finished.
- Block parts as necessary to prevent their sudden movement while people are working on the machine.
- Never attempt to clear away jammed feed material, discharge material or other stoppage while the machine is running. Stop the equipment, lock out and tag out before touching this machine with your tools or your hands.
- Wear proper personal protective equipment, including eye protection, hard hat and safety shoes, whenever you're near this machine while it is running.
- Dress appropriately in every way. Never wear loose clothes, long hair, coat tails, jewelry, pockets full of tools or any other item that could get caught in moving parts.
- Know where your fellow workers are. Always look around and inside this machine before starting it. Make sure nobody is in the way of moving parts or working on the machine.
- Lift with your legs, not with your back. Keep the weight close to your body. If the load is more than 40 lbs., get someone to help you.
- Never engage in horseplay when near this machine, or any other.
- Report any defective machinery or equipment and unsafe conditions or activity to your boss immediately.

- Don't limit safety practices to the few rules listed here. Think safety and act safely at all times.
- Most of all, know your equipment. Understand the machinery, the conditions under which it operates and what it is capable of doing.

Work Area Safety

- Keep the work area as neat and clean as practical.
- Keep all product safety signs clean, clear and current.
- Make sure all electrical equipment is properly grounded. Wet spots near electrical current are especially dangerous.
- Store hazardous materials in restricted access areas and mark them clearly. Federal regulations require special labeling of certain materials.
- Never start an engine in an enclosed space without properly venting the exhaust.
- Do not smoke or allow smoking near fuels and solvents. Never strike a spark or use an open flame near fuels and solvents.
- Store flammable fuels, solvents and gases in secure, well ventilated areas. Never allow fumes to accumulate in the storage area. Use nonflammable solvents for cleaning parts and equipment whenever possible.
- Know where fire extinguishers and other fire-suppression equipment are located. Learn how to use them effectively.
- Be alert and wary around any pressurized system, hydraulic or pneumatic. High-pressure oils and gases are very dangerous.

Personal Safety

Equipment & Tools

- Clean tools that are properly labeled and stored are safer tools. Keep your tools in good order.
- Keep drive belts and sheaves in good condition. Frayed belts or cracked sheaves are not only dangerous, they cost you downtime.
- Always use mechanical assistance to lift heavy loads. Never overload a hoist, crane, jack or other lifting device. Check lifting tackle regularly; replace it at the first sign of stretch, fraying or other wear.
- Keep your equipment clean, free of dirt and grease, so that loose, cracked or broken parts are more easily spotted. Replace defective parts as soon as they are discovered.

What is Lockout & Tagout?

What is Lockout & Tagout?

Lockout & Tagout is a procedure that's designed to prevent the unexpected or accidental startup of equipment and to alert all workers whenever it is unsafe to operate any piece of equipment. When used as intended, Lockout & Tagout also protects personnel from energy stored in devices such as springs, accumulators, batteries, hydraulic systems, etc.

When is Lockout & Tagout required?

- Any time anyone is maintaining, repairing, lubricating, or, for whatever reason, working on the equipment.
- When the equipment is broken or, for whatever reason, unfit or unsafe to operate.
- While clearing blocked or jammed mechanisms.
- Whenever the equipment is left unattended.

Who must apply a lock & tag?

- Any person working on the equipment.
- Foreman or other person responsible for the work being done.
- If several people are working on a machine at the same time, each person must apply his or her own lock and tag.

When can a lock and tag be removed?

After performing these six steps:

- 1) All safety guards are back in place.
- 2) All work is complete and tools are put away.
- 3) All workers are notified that a lock is being removed.
- 4) All workers are positioned safely for startup.
- 5) Controls are positioned for safe startup.

- 6) The machine is ready for safe operation.

Who can remove a lock and tag?

- Only the person who applied a lock and tag is permitted to remove them.

Lockout & Tagout rules laid out here are generic. To get instructions for your particular workplace, consult your employer's lockout/tagout procedure.

Screed Safety Information

Screed Safety Information

Training and Knowledge

Proper training and equipment knowledge is essential to the safe operation of this machine. Carefully read the entire manual before attempting to operate the paver. Keep this manual for future reference.

⚠WARNING

Do not operate this equipment until you have been trained in its operation or maintenance. This equipment may only be operated or maintained by trained personnel, who have demonstrated their ability to do so safely.

Safe Paver Operation

The following safety information concerns the operation of your paver.

⚠DANGER

- All guards and protective devices must be in place when the paver is being operated or moved.
 - Keep all personnel clear of augers when the paver is operating.
 - Do not refuel the paver with the engine or screed heater system running. All sparks and open flames must be kept a minimum of 50 feet away from the paver when refueling.
 - Do not wash or spray down the screed or tractor with the screed heater system operating.
 - Read, understand and follow all current OSHA, federal, state and local regulations that are applicable to your job and equipment.
 - This equipment must be used in accordance with all operation and maintenance instructions.
 - All persons involved with this equipment must be familiar with this manual.
 - Read, understand, and follow all Danger, Warning, Caution and instruction decals in this book and on the paver.
 - When changing the paver configuration or adding equipment to the paver, all additional guards associated with the added equipment must be installed before operating or moving the paver.
 - Any changes made to the original design of the paver must be approved by qualified personnel to ensure that the changes include appropriate guarding and provide a safe working environment for all personnel.
 - Wear clothing that fits snug to prevent getting caught in moving parts. Loose-fitting clothing should never be worn.
- Install all auger guards and vibrator covers before operating the paver.
 - Never attempt to install or remove any part or assembly when the paver is running.
 - Do not allow personnel to stand or walk between the front of the paver and the back of the truck while the paver is operating.
 - Attach screed safety cables or lower the screed before performing any inspections, repairs or adjustments to the screed.

Screed Safety Information

- Mount and dismount the paver from the rear using only the steps, handrails and walkways provided.
- Do not mount the paver when it is moving.
- Allow only the operator on the operator's platform when the paver is in operation.
- Before starting the paver, make sure the brakes are ON, all other systems are OFF and all personnel are clear.
- Before leaving operator's seat, always place the brake switch ON, and all other controls or switches in OFF or NEUTRAL position.
- Reduce travel speed when going down step grades to prevent over-speeding.
- Do not allow personnel near the hopper area when the paver is running.

⚠ CAUTION

- Wear protective mask when harmful air pollution exists.
- Wear safety goggles, gloves and long-sleeve shirts when working near hot asphalt materials.
- Wear ear plugs while paver is running.
- Keep operator's platform, steps and screed walkways clear of all obstructions, tools and other items to prevent tripping or falling.
- To prevent fire hazards, keep the screed and engine basket area free of oil, asphalt and trash buildup.

Screed Safety Information

Receiving New Equipment

Section 3 - Set Up and Operation

Receiving New Equipment

Pre-Operation Check

Before accepting and unloading a new paver, the consignee must inspect the equipment for evidence of damage or missing parts. This inspection process should be thorough, because once the freight receipt is signed, it is assumed that all of the equipment listed on the receipt was received in good condition.

Make a thorough inventory of all loose components packaged in boxes. A check list is provided in each box listing the components in the box. While performing the inventory, inspect all loose components for damage which may have occurred during transit. Any damage that happens to the equipment in transit is the responsibility of the carrier **not** Cedarapids. Claims for damage must be submitted to the carrier for settlement.

When evidence of damage or loss is discovered, have the driver make a notation on both the carrier's and consignees' copies of the freight bill. Prior to signing the freight bill, take pictures of the damage and identify the truck if possible. The consignee can then sign the bill to acknowledge delivery. The consignee should then have the carrier's terminal manager or his authorized representative make an official inspection of the damage or loss.

Equipment should not be moved from the original receiving point until this official inspection has been made. Good clear photos will verify and explain damage in any claim action which may follow. When the inspection is done, the consignee should file a written damage claim with the carrier's office and should report this action to the area distributor for Cedarapids Inc.

If hidden damage is found after the carrier's representative has gone, do not continue to unpack or move the equipment. Contact the carrier's local office and have the terminal manager or authorized representative make an immediate personal inspection of the damage. Obtain a written description of the damage, and photos if possible, signed by the representative as proof of a valid claim.

A packet of equipment warranty/start-up information will be sent to the distributor before the equipment leaves the factory. All warranty/start-up forms must be filled out and returned to Cedarapids within **24 hours** after the equipment is received.

Principle Of Operation

Principle Of Operation

The Stretch 16 and 18 screeds apply one or more layers of hot mix asphalt to create a smooth well-drained road surface. The screed is towed by the tractor that has adjustable pull points (Figure 3 - 1). The combination of the pull point height positioning and mat thickness hand crank adjustments provide for changes to be introduced to the screed attack angle. The slight positive angle of attack allows the screed to ride up and float on the hot mix.

The screed bottom flexes at its midpoint into a slight V-shape (negative crown) or into a slight inverted V-shape (positive crown). Such adjustment produces a negative or positive crown on mat for specified water drainage requirements.

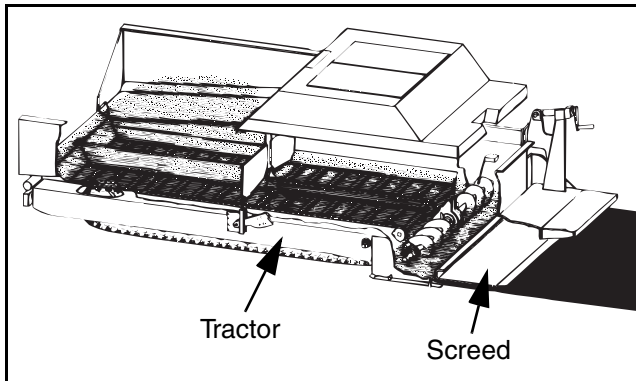

Figure 3 - 1 Asphalt Flow

Asphalt Flow

Vertical movement of pull points will cause the attack angle of the screed bottom to change. This in turn causes the screed to establish a new level. This self leveling action of the screed keeps the mat surface at a uniform grade.

The screed also has a burner or electric element to heat the screed bottom to the temperature of mix prior to paving. Preheating the screed bottom allows the hot asphalt to pass under the screed without sticking to the cold screed bottom.

Equipment Description

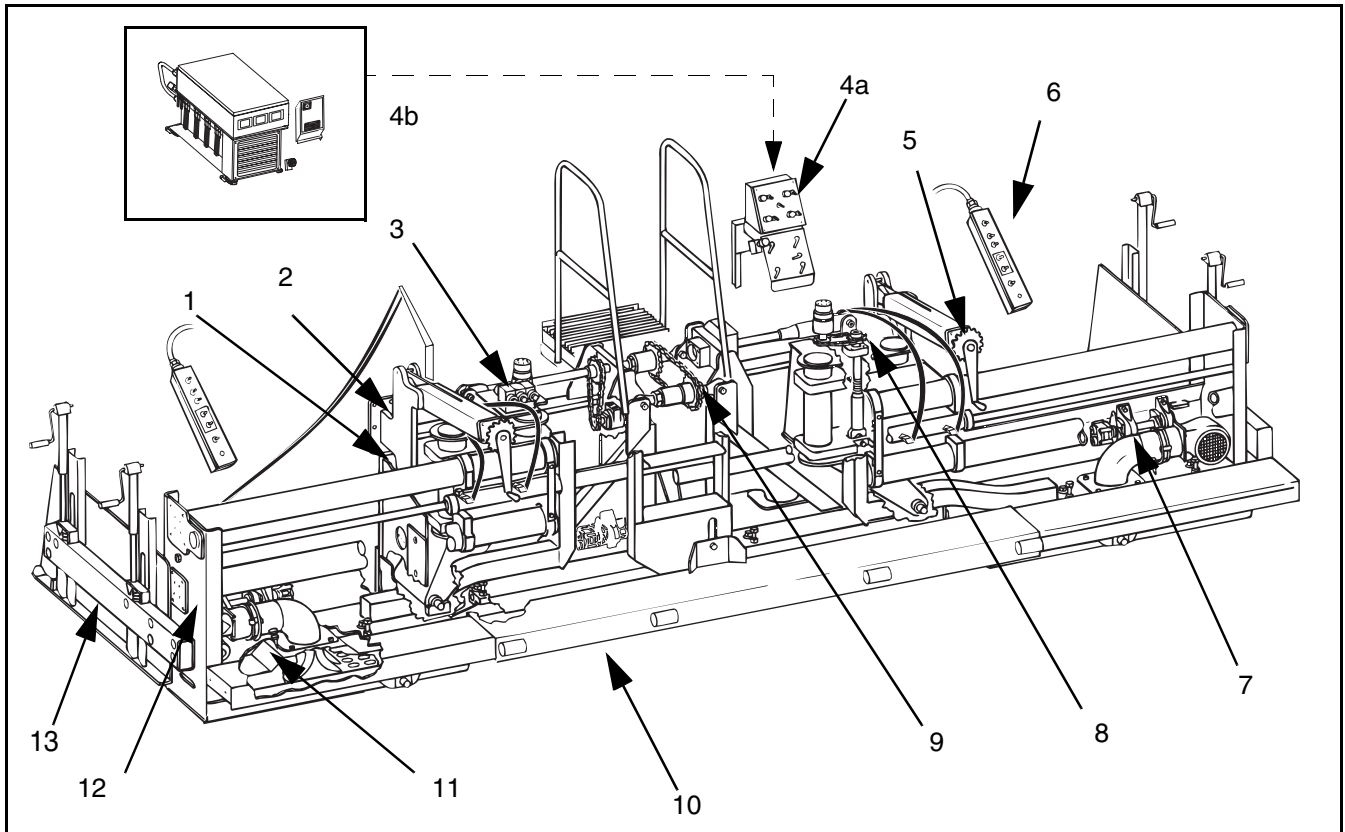

Figure 3 - 2 Stretch 16 & 18 Screed Components

- | | |
|---|--|
| 1) Main Screed Section | 9) Crown |
| 2) Pull Arm Mount | 10) Walkways |
| 3) Slope Indicator (not visible) | 11) Burners (fuel burner models) or Electric Heating Elements (electric screed models only--not shown) |
| 4a) Fuel Burner, Fuel, and Vibrator Control Panels (fuel burner models only) | 12) Left/Right Rear Extending Screed Sections |
| 4b) (Inset) Electric Screed Heat and Vibrator Control Panels (electric models only) | 13) End Gates |
| 5) Depth Crank | |
| 6) Remote Screed Control | |
| 7) Vibrator | |
| 8) Match Height | |

Equipment Description

Detailed Equipment Callouts

Refer to the figure on the previous page for equipment callout locations.

1) Main Screed Section

2) Pull Arm Mount

The screed is connected to the tractor at the pull arm mount.

3) Slope Indicator

The main screed section can be tilted to produce a slope mat surface. The rear extending screed sections can be tilted independently as needed to produce a sloping shoulder in the final mat.

4a) Fuel Burner/Vibrator Control Panels

(Fuel burner models only) Controls burners for preheating the screed bottoms, flow of fuel for burners and spraydown equipment, as well as vibrator speed.

4b) Electric Screed Heat and Vibrator Control Panels

(Electric models only) - Controls generator, electric heating elements and vibrator speed. Also location of circuit breakers for heating elements.

5) Depth Crank

Adjusts the angle of attack of the screed bottoms to increase or decrease the thickness of the mat.

6) Remote Screed Control

Portable control panel used to adjust match height, crown, slope, mat thickness, and extension width (see Figure 3 - 12).

7) Vibrator

Vibrators increase the compaction produced by the screed. Vibrator frequency and amplitude can be adjusted for mat and mix specifications.

8) Match Height

Rear extending screed sections can be raised or lowered as needed to match the height of the main screed bottom.

9) Crown

The main screed bottom can be deflected at the center to produce a positive or negative crown in the mat.

10) Walkways

Allow screed operator to move along the length of the screed while the screed is in motion without walking on the newly placed mat.

11) Burners

Fuel burners preheat the screed bottom to prevent asphalt from sticking to the screed bottom *(fuel burner models only)*. On electric models, electric heating elements supplant burners (not shown).

12) Rear Extending Screed Sections

Rear extending screed sections can be adjusted hydraulically to any width from zero to four feet on each side of the screed.

Equipment Description

13) End Gates

Mounted on the end of the rear extending screed sections. The end gates prevent material from spilling out past the end of the rear extending screed section and produce a square or bevelled edge on the mat.

⚠ WARNING

Always make sure everyone is clear of the screed before raising or lowering the screed.

Remote Controls

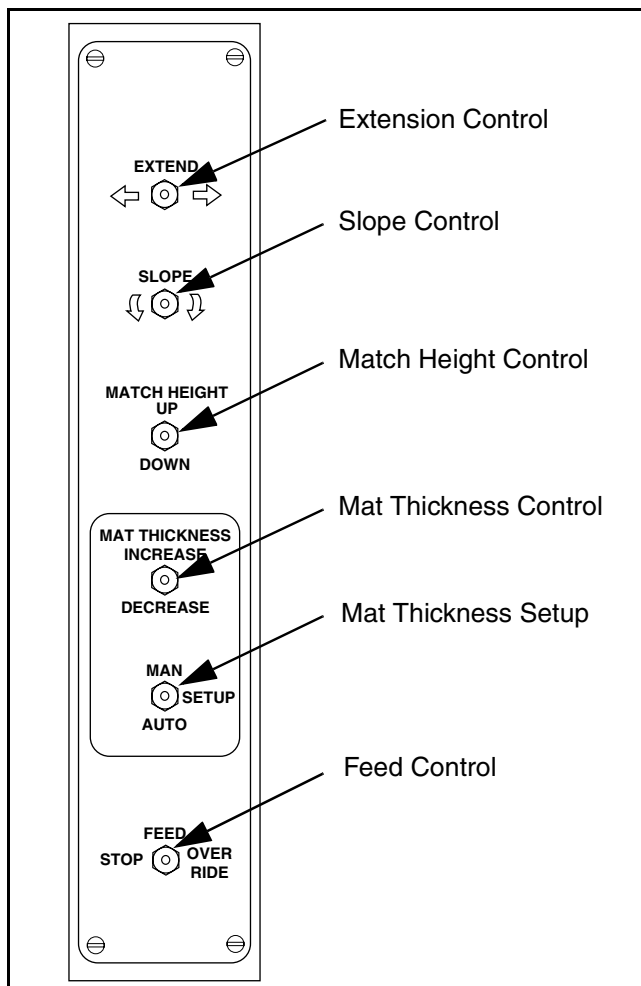

Figure 3 - 3 Remote Control Panel for Raising and Lowering Screed

Raising and lowering the screed is accomplished by two double-acting hydraulic cylinders mounted on the rear of the pull arms. The cylinders are controlled by electric solenoid valves mounted on the tractors rear bulkhead. The screed is raised using the Screed Lift switch on the tractor operator console.

When engine is at FULL throttle and screed lift switch is held in the RAISE position, the screed will rise until it reaches maximum height or the switch is released. When the switch is released it will automatically return to the neutral position where the screed is hydraulically locked at the existing height. While paving the screed lift switch must be in the LOWER/FLOAT position. This position allows the screed to float over mix at the preset mat thickness.

Supporting an Elevated Screed



Always make sure screed is locked in the up position or supported using blocks before working under or around an elevated screed and while traveling with the screed elevated.

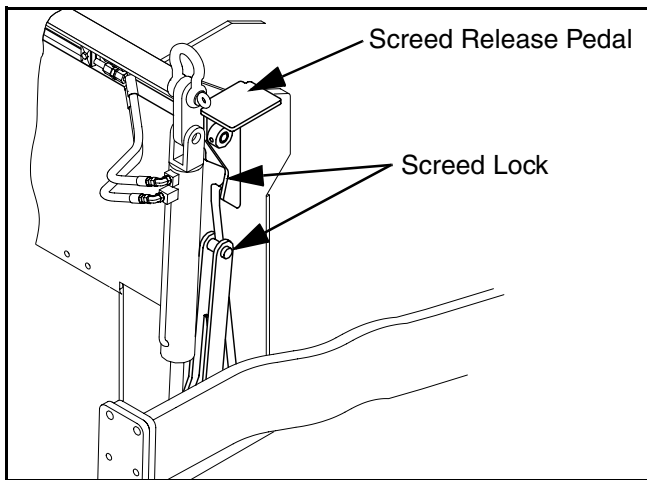

Figure 3 - 4 Screed Lock

To lock screed in up position, raise screed to the upper limit until lock engages. To lower, step on screed release pedal and lower screed.

To hook safety cables, raise screed to the upper limit and hook cables. Lower screed until no slack can be observed in the cables.

Equipment Description

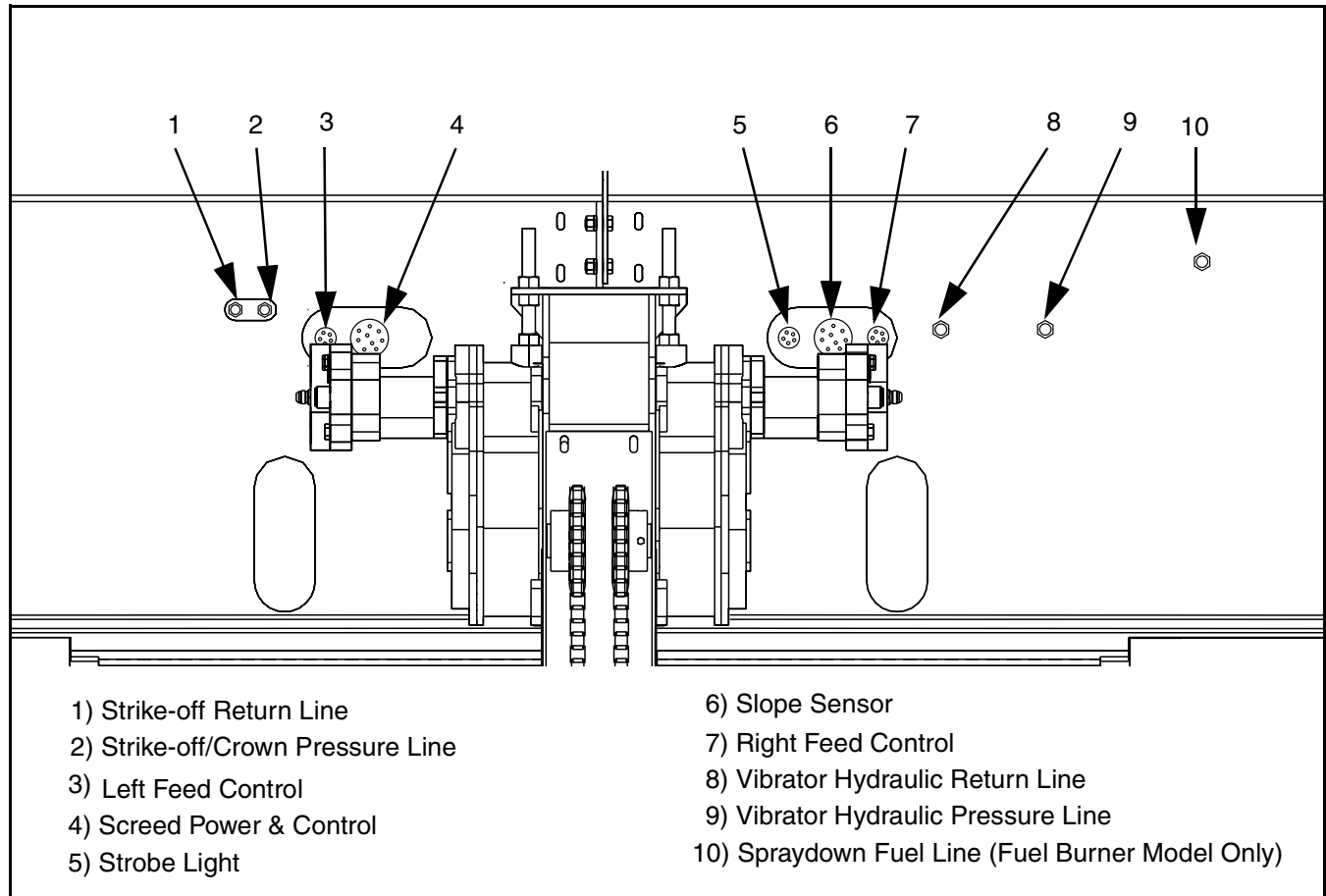

Figure 3 - 5 Hydraulic and Electrical Disconnects

Detaching Screed from Tractor

The screed may need to be detached from the tractor because:

- Maintenance and repair work on screed and on rear of tractor can be more easily performed with screed removed.
- A screed with extensions can be detached and hauled lengthwise on a truck bed.
- Smaller trucks can be used to transport separated tractor and screed.
- The tractor can be driven on a steeper ramp with the screed removed than with the screed installed.

CAUTION

Screed detachment must be performed correctly to prevent damage to the screed or tractor.

- 1) Lower the screed to the ground.
- 2) Unplug all hydraulic hoses and electrical cables from tractor. Plug or cover open connectors on both tractor and ends of hoses or wires using protective covers provided.
- 3) Remove the four bolts on each pull arm coupler and move tractor forward.

Preheating the Screed

Preheating the Screed

The Stretch 16 and 18 screeds are equipped with a heating system for preheating the screed bottom. The screed is preheated using either fuel burners (see *Section 4, Fuel Burner Operation*) or electric heating elements (*Section 5, Electric Screed Operation*). Refer to the appropriate section for your model to review specific instructions on heating system operation.

The heating system is used to raise the temperature of the screed bottom to approximately 300° F before it contacts the hot mix. This allows the mix material to flow under the screed bottom without sticking and produces a more uniform mat surface texture. When paving begins the heating system is usually shut off as the hot mix will maintain proper screed temperature without an additional heat source.

If material delivered to the hopper has cooled too much, mat texture may be improved by running the screed heating system. When hauling long distances, it may be necessary to raise the temperature of the mix at the mixing plant to restore efficient production of a high quality mat.

Recommended temperature for material delivered to the paver is 250° F minimum when medium or high penetration asphalt is used. For low penetration asphalt a minimum of 300° F is required. Many mat defects are results of incorrect material temperature at the time of paving.

On screeds with fuel burner heating systems, the screed bottom will be sufficiently heated by running the burners for 15-20 minutes before operation. However, the screed may require 30 to 60 minutes to preheat depending on ambient temperature, wind conditions and thickness of screed bottom.

CAUTION

Do NOT overheat the screed bottom! Overheating can damage the screed bottom.

CAUTION

On models equipped with fuel burner heating systems, pay close attention to the area of the screed bottom directly under the burner while preheating the screed. This area will warm up more quickly than the rest of the screed and could overheat if not watched closely.

CAUTION

Fuel burner heating systems must be turned off before paving begins. Running the heaters while paving could burn the mat or create a hot spot on the screed bottom.

NOTICE

Always preheat all of the screed sections. If paving at ten feet wide it is necessary to preheat both the main and rear screed sections.

Operating the Screed

Operating the Screed

Mat Thickness Control

The screed angle of attack must be adjusted based on desired mat thickness and mix design. Refer to the Quality Paving Guide for detailed instructions on how to determine the correct angle of attack setting.

Thickness of material deposited is determined by the angle of attack of the screed bottom.

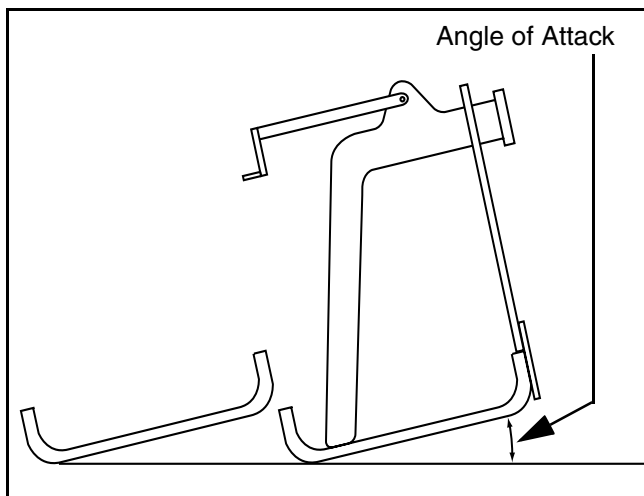

Figure 3 - 6 Screed Angle of Attack

Screed bottom attack angle adjustment is made by vertical movement of pull points (Figure 3 - 6). Use the mat thickness switch (INCREASE or DECREASE), on remote control box, to alter pull point height. This method of attack angle adjustment should be the primary means of obtaining the desired mat thickness in the MANUAL mode.

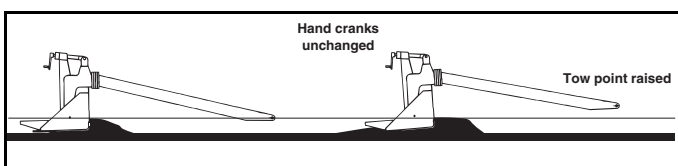

Figure 3 - 7 Angle Change Moving Tow Point

Manual attack angle adjustment (mat thickness) can be made by turning hand crank at each end of screed. When hand cranks are turned clockwise, they increase the screed attack angle producing a thicker mat. When the hand cranks are turned counterclockwise, they decrease the screed attack angle producing a thinner mat. If the screed was purchased with the optional opposite rotation hand cranks, the rotation directions will be reversed.

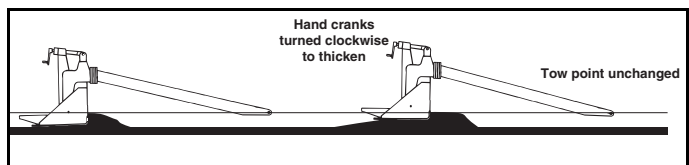

Figure 3 - 8 Angle Change Moving Hand Crank

Mat thickness at each end of screed is controlled independently so that a tapered mat can be laid in order to level or to super elevate a roadway.

Change of material specifications will usually cause a different screed behavior requiring different pull point setting, while mat thickness remains constant. To obtain a smooth mat, screed adjustments should be made gradually and screed should travel a few feet before an additional adjustment is made. This allows screed to seek new level of operation.

If a paver is equipped with automatic screed control, the operator will normally set up the screed using manual adjustments before switching on the automatic system. Both pull points should be adjusted to the same height at start-up.

Operating the Screed

Screed Pull Arms

Screed pull arms are attached to the paver at a single point on each side of the tractor (Figure 3 - 9). As the tractor follows the contour of the existing road surface, the pull arms are allowed to move independently to maintain a consistent line of pull. This system allows the screed to cover over irregularities found in grade and base material and produce a new smooth ride surface.

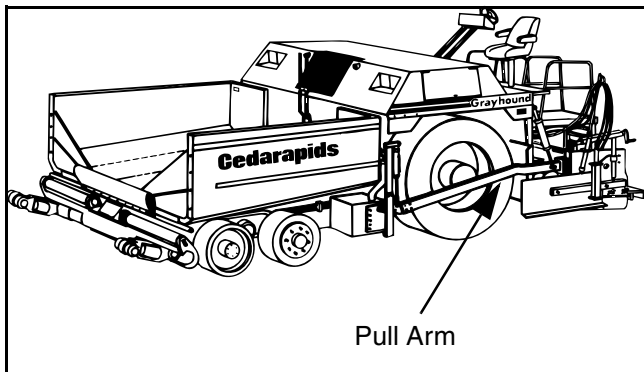

Figure 3 - 9 Pull Arms

Pull Point Cylinder Speed Test

Speed adjustment (flow control) valves are included in the hydraulic system for each pull point cylinder so the speed of mat thickness correction can be regulated. These valves make very fine control of flow possible.

The flow control valve is factory set and should not require a change. If one or both pull points react too slow or too fast to changes in grade line, the following test should be performed.

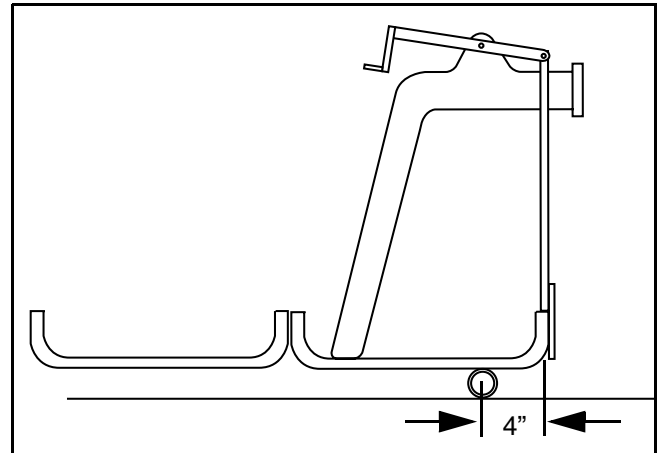

Figure 3 - 10 Pull Point Speed Test

- 1) Place the paver on a flat hard surface. Place a 2" (O.D.) or larger pipe under each end of the main screed to serve as a pivot (Figure 3 - 10). Lay pipe parallel to leading edge of the main screed and exactly 4" from leading edge.
- 2) With engine running at FULL throttle, set mat thickness switch on remote control box to MANUAL.
- 3) Use the mat thickness switch (INCREASE/DECREASE) and stroke the cylinder from one end of stroke to the other. Total time required should be between 15 and 18 seconds in each direction.
- 4) If not, adjust the pull point flow control valve on the tractor as needed to get the stroke time within the 15 to 18 second range.
- 5) Perform this procedure on both the left and right pull points to ensure both pull points move at the same speed.

Operating the Screed

Pull Point Position

Screed pull points are raised or lowered by pull point cylinders controlled by the mat thickness switch on remote control box. For normal types of material and mat thickness, the pull point cylinders should be set at midstroke. A decal mounted on the pull point cylinders indicates the current position of each pull point (Figure 3 - 11).

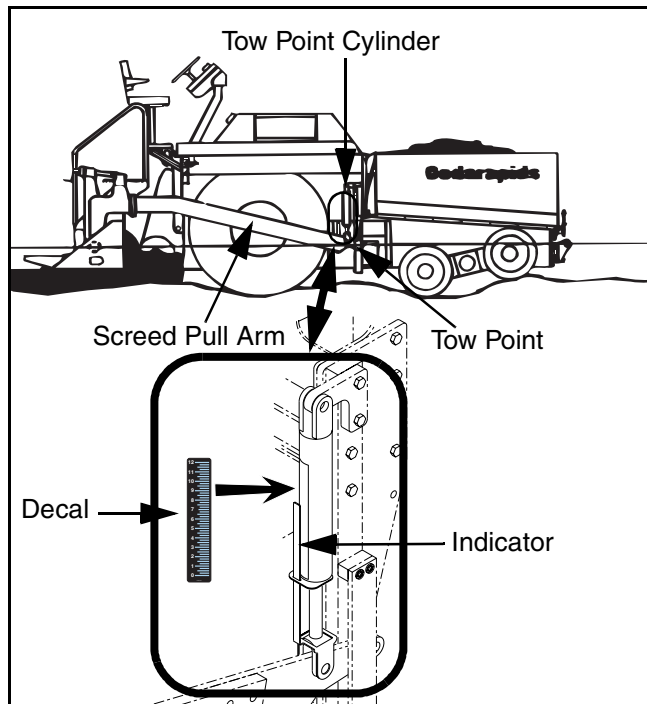

Figure 3 - 11 Tow Point Indicator

NOTICE

The pull points should be reset to the midpoint and the screed nulled at the start of each day. When adjusting pull points to the desired setting, make sure both are adjusted the same. If pull points and hand cranks are excessively out of balance, it causes the screed to twist resulting in poor mat surface.

The pull point most critical settings are with low stability sandy mixes. If screed tends to sink and ride on trailing edge due to unstable mix or a thick mat requirement, pull points can be raised to improve mat. If the paver is required to lay a very thin mat, pull points can be lowered to give screed better flotation and greater initial density to mat.

Correct pull point settings become a matter of experience. Locating mid-stroke of pull points as noted has proven satisfactory for most paving jobs. The softer and more unstable the material, the more important it becomes to have screed bottom flat with mat.

NOTICE

Unstable mixes can be caused by too much asphalt in mix, poor gradation, poor quality asphalt, excessive temperature, moisture in material, and/or insufficient dust.

Operating the Screed

Effects of Pull Points Positioned Too High

When pull points are too high and the screed is adjusted to compensate for this, the screed bottom will wear more on the leading edge. See Figure 3 - 12. This could cause some of the following problems:

- 1) Premature failure of leading edge of screed bottom and possible damage to strike-offs.
- 2) Bumpy, wavy mat caused by screed riding on its leading edge.
- 3) Tendency for screed to dip each time paver starts moving.
- 4) Torn mat caused by “digging in” action of leading edge.
- 5) Loss of compaction caused by trailing edge of screed not being in contact with mat being laid. Vibrators connected to screed bottom support will not be operating efficiently as full screed width is not being utilized. Mat appearance and texture will change with only slight movement of mat thickness hand cranks.

Effects of Pull Points Positioned Too Low

When pull points are too low and the screed is adjusted to compensate for this, the screed bottom will wear more at the trailing edge. See Figure 3 - 12. This could cause some of the following problems:

- 1) Premature failure of trailing edge of screed bottom.
- 2) Tendency for screed to climb each time paver starts moving. Poor control of mat thickness will exist and good transverse joints will be difficult to make.

- 3) Possible tearing of mat caused by excessive ironing effect of screed.

Correct Tow Point Position

Correct tow point positioning will result in more uniform wear of the screed bottom as well as better mat texture. See Figure 3 - 12.

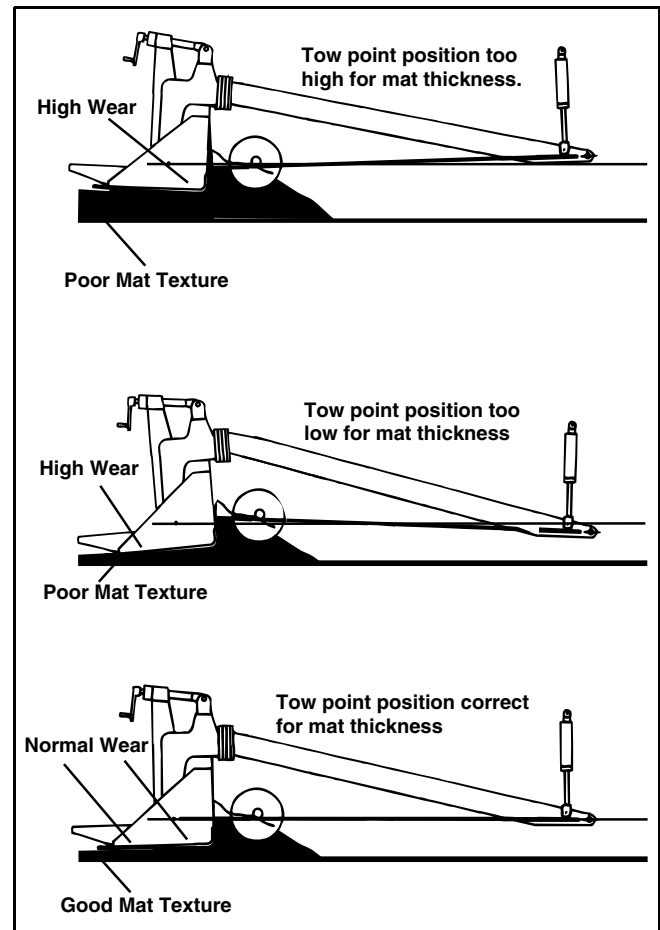

Figure 3 - 12 Effects of Tow Point Position

Screed Adjustments

Mat Crown Control

The flat screed bottom can be flexed at its center to produce a finished mat having a positive or negative crown for water drainage. For 10' wide paving, maximum positive crown is 3" and maximum negative crown is 1" (see Figure 3 - 13). The crown gauges provide a crown reference.

Crown adjustment is accomplished by means of two hydraulically driven adjusters (Lead & Trail). The crown adjustment is controlled at the main screed control panel.

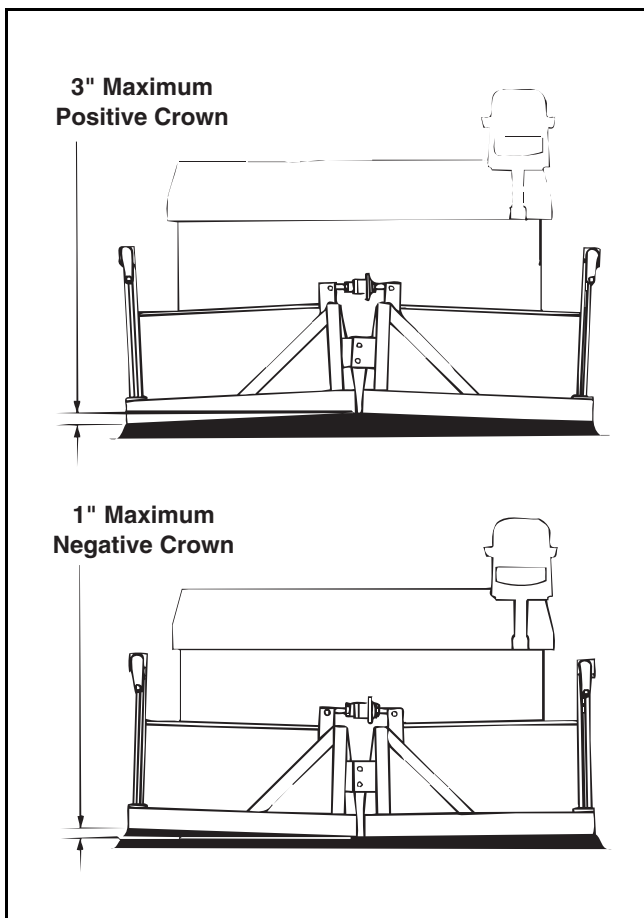

Figure 3 - 13 Controlling Mat Crown

Screed Adjustments

General

All screed adjustments in the following sections should be made only after setting the tow point cylinders to the same position, equally nulling screed hand cranks, and zeroing lead and trailing crown.

Use the Manual Jog switch to reposition both tow points at midpoint on the tow point gauge.

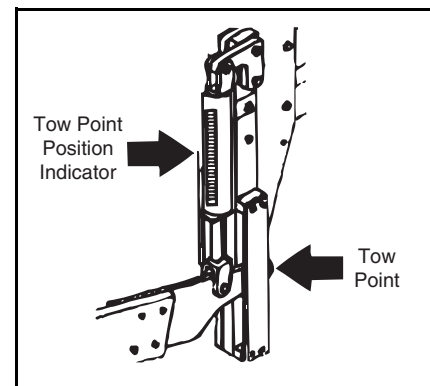

Figure 3 - 14 Tow Point Positioning

Nulling the Screed

Measure the distance from the screed frame to the tow arm plate on the left side.

Measure the distance from the screed frame to the tow arm plate on the right side and turn the screed hand crank one direction or the other until the measurement is equal to that of the left side (Figure 3 - 15).

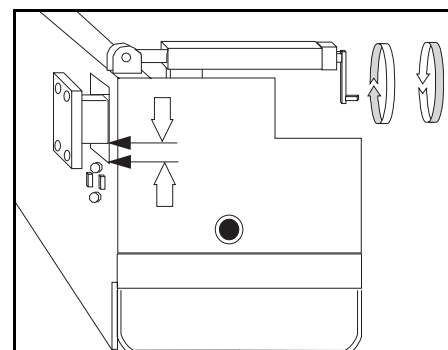

Figure 3 - 15 Nulling Screed

Screed Adjustments

Screed Bottom Flatness

NOTICE

The trailing edge flatness must be checked from time to time to ensure that the mat produced will be flat across the entire width of the screed.

- 1) Starting from the center line of the screed bottom, place a five-foot straight edge from the center to the outside edge. The straight edge should be placed along the trailing edge of the screed bottom.
- 2) Check the screed bottom along the length of the straight edge for flatness. If the screed bottom is not flat, loosen the retaining bolt adjacent to the shim bolt and tighten the shim bolt as needed to flatten the trailing edge. (Figure 3 - 16). Retighten the retaining bolt.

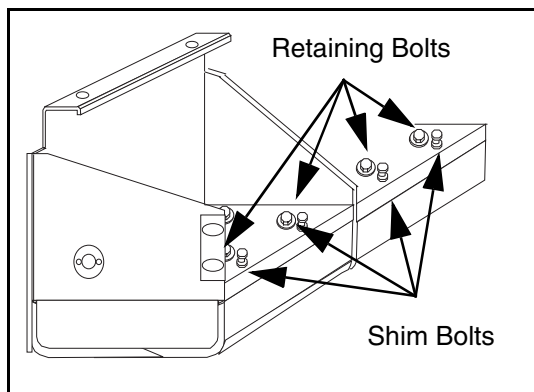

Figure 3 - 16 Screed Bottom Flatness

Fixed Strike-Off

The fixed strike-offs act as a material metering device to control the amount of material allowed to pass under the screed, thereby controlling or affecting the angle of attack required to produce a given depth. They also absorb wear that would have been introduced to the nose area of the screed

bottom. The normal strike-off setting is 1/2 inch above the screed bottom and will work fine in most material designs currently used. There are some material designs that will require changing the setting to allow the screed to run with the desired 1/8 inch to 1/4 inch nose-up attitude or angle of attack.

To check and adjust the strike-off:

- 1) Place a straight edge against the bottom of the screed and measure from the straight edge to the bottom of the strike-off (Figure 3 - 17).
- 2) Adjust the strike-off by loosening the bottom jam nut on the strike-off adjusters and tightening the top nut to raise the strike-off. Loosen the top jam nut and tighten the bottom jam nut to lower the strike-off.
- 3) Check the strike-off setting at both the inside and outside edges of the screed.

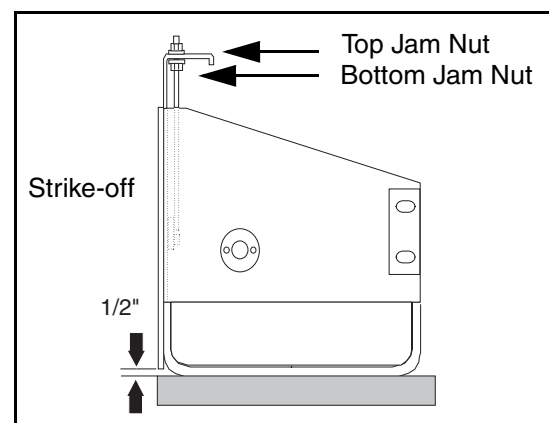

Figure 3 - 17 Strike-Off Adjustment

Lead/Tail Crown

The main screed crown has two adjusters, the lead & tail. The lead and tail crown can be adjusted simultaneously to add a crown to the final mat. The lead crown can be set independent of the tail, to allow a little extra material to pass into the center area of the main screed. This is necessary to compensate for the void area created by the auger-

Screed Adjustments

conveyor drive case. Typically the lead crown is 1/16" to 1/8" above that of the tail. This range is sufficient for most mixes.

The most common way to check the lead and trail crown is to use a strong string line, two equal thickness spacers (new 1/2" NC nuts) and a tape measure.

The first check to be performed is checking and adjusting the tail crown.

- 1) Place two spacers near the outer edge of the screed bottom and just foreword of the trailing edge.

NOTICE

A screed that has been used in a joint matching application may have a few inches on the outer edge of the screed bottom that are worn more than the rest of the screed bottom. In such a situation the spacers will have to be placed inboard of the worn areas to get a proper measurement.

- 2) Stretch a strong string line across the center of the spacers and pull tight.
- 3) Measure the distance from the string line to the screed bottom next to each spacer and in the center of the screed (Figure 3 - 18).

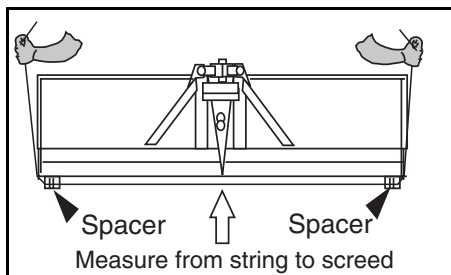

Figure 3 - 18 String Line Location

- 4) For initial setup purposes adjust the lead and tail crown to 0" (flat). If the measurement in the center of the screed is less than or more than the measurement near the spacers, the tail crown must be adjusted.
- 5) To adjust, press the crown switch located on the main screed control panel to Increase or Decrease. Adjust until measurement at center area of screed is equal to the measurement near the spacers.
- 6) Once the tail crown is set to 0" (flat), move the spacers and string line foreword to the leading edge of the screed bottom.
- 7) Measure the amount of lead crown.
- 8) To adjust the lead crown independent of the tail crown, remove the two clevis pins in the rear crowning sprocket. Press the crown switch to the increase or decrease position.
- 9) Adjust until measurement at center area of screed is equal to measurement at spacers.
- 10) Reinstall the two crown clevis pins in the rear sprocket.
- 11) Once the lead and tail crowns are set at zero inches (flat), loosen and reset the crown indicator gauges to zero.

Screed Adjustments

Final Crown Adjustment

Final crown adjustment is made after paving has started and actual mat crown can be accurately checked by taut string line. Final crown adjustment is always made after checking the crown of a rolled mat after enough mix has been laid to be certain the screed has stabilized.

- 1) Place spacers (2 X 4s) near the edges of the newly rolled mat. The spacers must be of equal thickness and be thick enough to hold a stretched string line above the crown of the mat.
- 2) Stretch a string line across the spacers and pull the string line tight.
- 3) Measure the distance from the string line to the mat at the peak of the crown and at each side of the mat near the spacers.
- 4) Adjust the crown as needed recheck the crown of the rolled mat until it matches the specified profile.

Match Height Adjustment

This adjustment is performed to make sure the rear extending screeds are positioned at the same height as main screed. Procedures described below are done for *both* rear extending screeds.

- 1) With the rear extending screeds fully retracted, check the match height across bottom of rear extending screed and main screed at outer edge. If the main and rear extending screed bottoms do not match, use the match height switch on the remote control to raise or lower the rear extending screed as needed.

- 2) When the outside edges of the screed bottoms are at the same height, check the height at inner edge. If the inner edges do not match, use the slope switch on the remote control to align the inner edges of the screed bottoms.
- 3) When both the inner and outer edges are matched, check match height scale pointer. If pointer is not at zero, loosen cap screws, align with zero, and re-tighten screws.
- 4) Extend the rear extending screed. Lay a straightedge across the main and rear extending screed bottoms. Both surfaces should be level if the preceding steps have been performed correctly.

Independent Angle of Attack

The rear extending screeds run with an increased angle of attack relative to the main screed to provide a uniform texture across the width of the mat. This is called the independent angle of attack.

NOTICE

The Match Height Adjustment above must be performed before adjusting the independent angle of attack.

To check and adjust the independent angle of attack:

- 1) Fully retract both rear extending screeds.
- 2) Place a straight edge on the outer edge of the main screed that extends under the rear extending screed.
- 3) With straight edge flat against the main screed bottom, the straight edge should contact the rear extending screed bottom at the trailing

Screed Adjustments

edge. There should be 1/8" gap between the leading edge of the rear extending screed bottom and the straightedge (Figure 3 - 19).

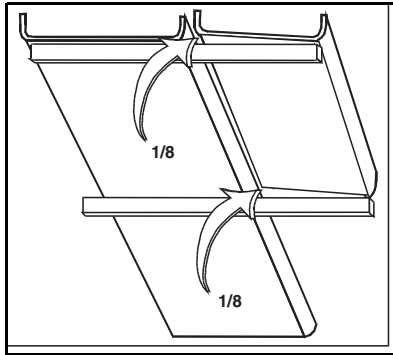

Figure 3 - 19 Gap Between Edges

- 4) To adjust the independent attack angle, first loosen rear retaining bolts on the extending screed, loosen jam nuts on shim bolts, then increase the attack angle by turning shim bolts clockwise or decrease the attack angle by turning shim bolts counterclockwise.
- 5) Once the desired angle is obtained, re-tighten jam nuts and retaining bolts. (Figure 3 - 20).

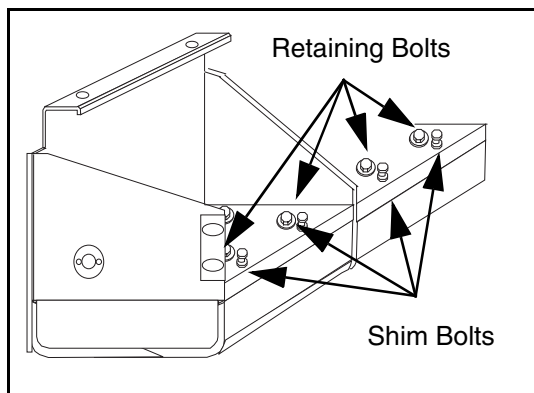

Figure 3 - 20 Adjusting Angle of Attack

Seal Plate

The seal plate must be adjusted to prevent asphalt from collecting between the main screed and rear extending screeds. Failure to adjust the seal plate

can result in mix working its way between the front and rear extending screed bottoms causing a “trail” of unpaved mix behind the screed.

At any extension width, the seal plates should be kept adjusted because hardened mix between the main and rear extending screeds cause additional wear and stress. Check seal plate each time the screed width is adjusted.

To adjust seal plate, loosen the two bolts and move the plate against the extension, re-tighten the bolts.

Extending Screed Alignment

An extending screed that is not parallel with the main screed can still function properly. The most obvious indication that the extending screed is not parallel to the main screed will be that the extender tubes will be out-of-line. When retracting the rear screed, the tubes may rub or hit part of the structure normally cleared or be noticeably misaligned with the tubes of the opposite rear extending screed.

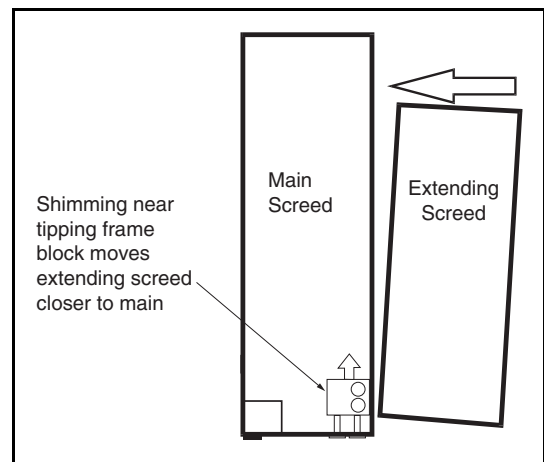

Figure 3 - 21 Extending Screed Alignment

To realign the extending screeds:

- 1) Retract both extending screeds.
- 2) Loosen inner and outer keeper bolts.

Screed Adjustments

- 3) Install a press bolt in threaded hole next to the outer keeper bolts and tighten. This causes the tipping frame block and extending screed to move.
4. Once the extending screed is aligned with the main screed, add shims between the tipping frame block and main screed frame (Figure 3 - 22).
5. Tighten the keeper bolts and remove press bolt (Figure 3 - 22).

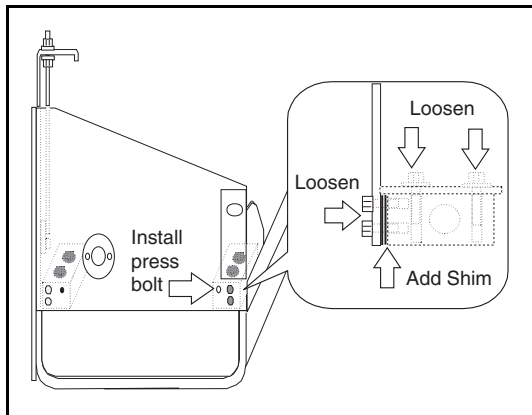

Figure 3 - 22 Shim Tipping Frame

Extending Screed Pre-Torque

Preloading the extending screed horizontal tubes counteracts the tendency of the extending screeds to be pushed back and downward by the pressure of the material in front of it. The pre-torque is factory set at zero inches and normally will not require adjustment.

If the extending screeds have a tendency to twist back and downward during wide width paving operations, the pre-torque should be checked and adjusted if necessary.

To check pre-torque:

- 1) Place a straight edge on the outer edge of the main screed and use the Match Height switch to raise or lower the rear extending screed until it just contacts the straight edge.

- 2) Place a straight edge at the center area of the main screed and use the Slope switch to increase or decrease the rear extending screed slope until it just contacts the straight edge (Figure 3 - 23).

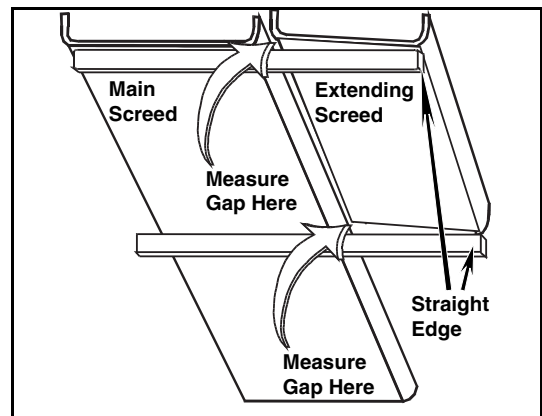

Figure 3 - 23 Checking Pre-Torque

- 3) The leading edge of the rear extending screed should be 1/8" above the straight edge.

When paving at wide width, the pre-torque can be increased to resist any twisting of the rear extending screeds.

Adjusting Pre-Torque

Adjust pre-torque in the following manner:

- 1) Fully extend the screed.
- 2) Loosen the four torque arm cap screws several turns. Place a level on frame of extending screed.

Screed Adjustments

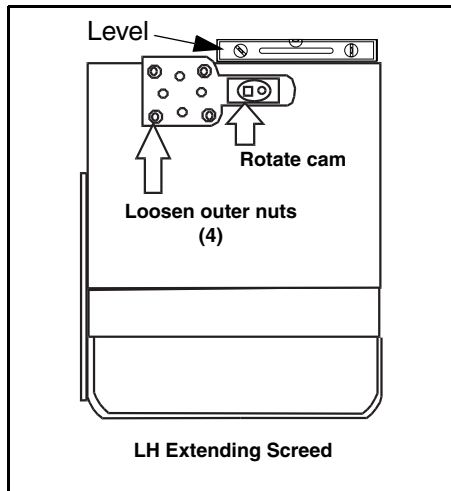

Figure 3 - 24 Adjusting Pre-Torque

- 3) Note the position of bubble on level when paver is at rest (Figure 3 - 24).
- 4) Start paving and note position of bubble on level while paving.
- 5) Adjust pre-torque so the bubble on the level while paving is the same as when the paver is at rest.
- 6) On the LEFT extending screed, loosen the cam bolt nut two turns. Using a 1/ 2" drive breaker bar, rotate the cam CLOCKWISE TO DECREASE the pre-torque. COUNTERCLOCKWISE rotation will INCREASE the pre-torque.
- 7) On the RIGHT extending screed, loosen the cam bolt nut two turns. Using a 1/ 2" drive breaker bar, rotate the cam CLOCKWISE TO INCREASE the pre-torque. COUNTERCLOCKWISE rotation will DECREASE the pre-torque.
- 8) When adjustment is complete, tighten all cap screws.

- 9) Retract the extending screeds fully in and check with a straight edge as before.
- 10) The setting should show the outer edge will measure greater than the inner edge now. This is indicating the extending screed now has pre-torque.

CAUTION

The pre-torque should never be increased above 1/16". Doing so could cause mat texture problems and introduce increased wear to portions of the screed bottom.

Screed Accessories

Screed Accessories

Screed Heating Units

The Stretch 16 and 18 model screeds come equipped with either a fuel burner system or a thermostatically controlled electric element to pre-heat the screed before beginning paving operations. Pre-heating the screed bottom to a temperature of approximately 300 degrees prevents sticking and allows for better material flow under the screed. See *Section 4, Fuel Burner Operation* or *Section 5 Electric Screed Operation* for details on using the heating system for your model.

CAUTION

Excessive heat can cause screed bottom to warp. Never heat above 350° F!

Screed Vibrators

Hydraulic vibrators on screed, which help with initial compaction and uniform smoothing of a high density mat, are activated by the toggle switch on the operator's console. Vibrators will only operate when travel lever(s) is FORWARD. This prevents extra compaction in one place on mat when paver is temporarily stopped.

Operating intensity of vibrators can be varied to produce more or less vibration. The vibrator speed knob (flow control valve) is located adjacent to heater control panel. A recommended start-up setting is 3/4 of range between zero and the highest dial marking.

Operating Screed Vibrator

- 1) With engine running, set paver speed dial to zero (MIN.).

- 2) Turn vibrator switch to ON, set brake switch to RELEASE, and move travel switch/lever forward.
- 3) To turn vibrators off, set vibrator switch to OFF, return travel lever(s) to neutral, and ENGAGE brake switch.

WARNING

Do not work on vibrators with engine running and do not operate without guards in place.

Screed Accessories

Vibrator Weight Installation and Alignment

Each vibrator weight eccentric consists of two plates mounted 120° apart and clamped to the vibrator shaft (Figure 3 - 25). There are four pairs of weights, two on each side of the screed, and two motors, one at the outer end of each shaft. Each extending screed also has two pairs of weights and a motor at the inboard end.

Weights are mounted at 120° to each other to produce adequate compaction for most mixes. If more or less compaction force is needed, the relationship of weights in each pair can be changed.

Aligning the weights closer together will produce more compaction force. When both weights are exactly aligned, maximum force is obtained. Aligning the weights opposite each other counter balances the force and provides no vibratory compaction force.

To reposition a weight, loosen with an Allen wrench and rotate the weight to the desired position. Only one weight will need to be moved.

NOTICE

All pairs of weights must be aligned along the length of the shaft to produce a synchronized vibrating force. This is very important to remember when installing screed extensions equipped with vibrators. Misalignment will reduce vibrating force across the screed affecting the quality of mat compaction.

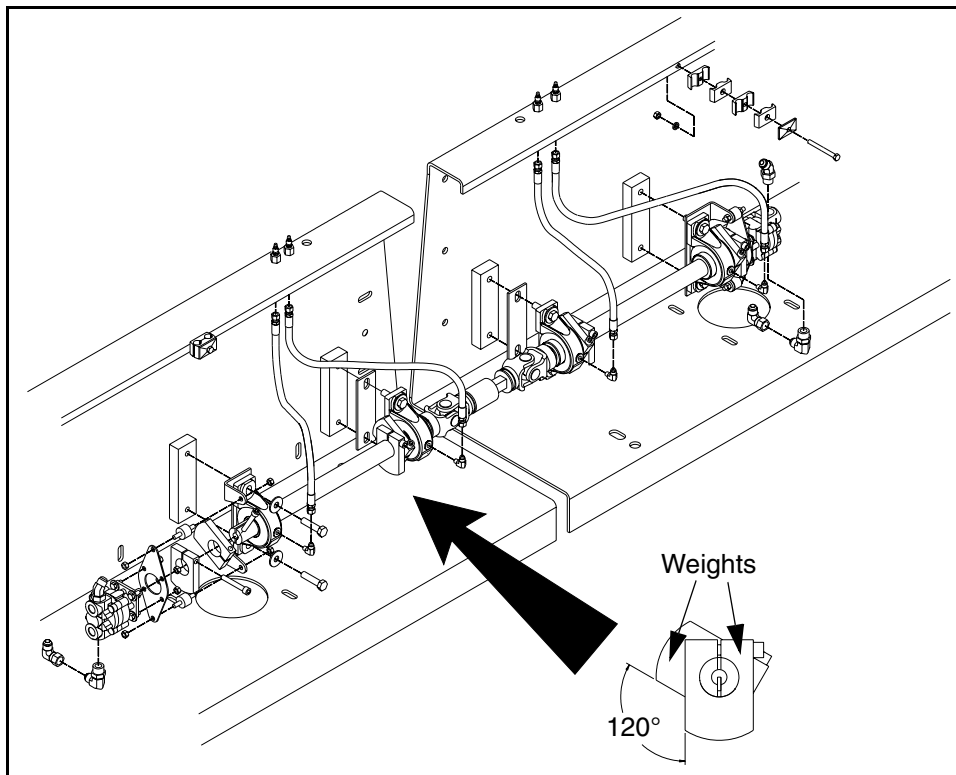

Figure 3 - 25 Vibrator Weight Eccentric Installation & Alignment

Screed Accessories

Strike-Offs

Strike-offs bolted to front of main and rear extending screed bottoms meter material to screeds. They also absorb wear which would otherwise take place on leading edge of screed bottoms. If these strike-offs are not properly adjusted and maintained they can cause operational difficulties.

NOTICE

A silicone additive is often added to asphalt to improve mix laying characteristics of hot sand or fine mixes. Use of this additive may require adjustment of the strike-offs.

Adjusting Strike-Off

The fixed strike-offs act as a material metering device to control the amount of material allowed to pass under the screed, thereby controlling or affecting the angle of attack required to produce a given depth. They also absorb wear that would have been introduced to the nose area of the screed bottom. The normal strike-off setting is 1/2" above the screed bottom and will work fine in most material designs currently used. There are some material designs that will require changing the setting to allow screed to run with the desired 1/8" to 1/4" nose-up attitude or angle of attack.

To check and adjust the strike-off:

- 1) Place a straight edge against the bottom of the screed and measure from the straight edge to the bottom of the strike-off (Figure 3 - 26).
- 2) Adjust the strike-off by loosening the bottom jam nut on the strike-off adjusters and tightening the top nut to raise the strike-off. Loosen the top jam nut and tighten the bottom jam nut to lower the strike-off.

- 3) Check the strike-off setting at both the inside and outside edges of the screed.

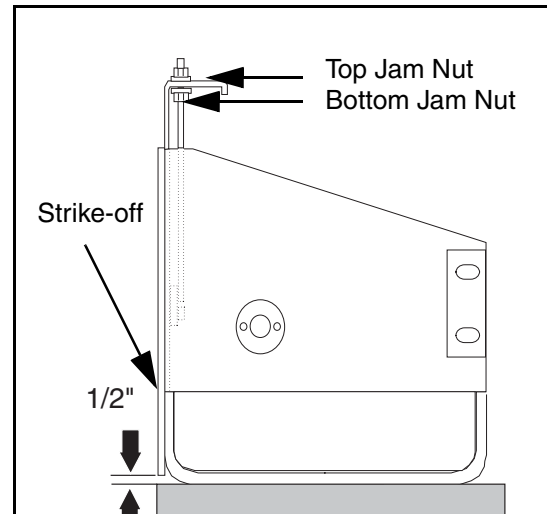

Figure 3 - 26 Strike-Off Adjustment

Extension Vibrator

Vibrators on fixed extensions are driven by a telescoping U-joint shaft coupler. Install the U-joint coupler between vibrator shafts on the fixed extension and rear screed.

Installing Screed Extensions

Fixed extensions can be added to the screed to extend the base paving width by an additional 14 inches. Quick-attach studs and key wedges allow for a minimum of effort when attaching the extensions.

WARNING

Screed extensions are heavy and can not be installed safely and correctly by one individual. Do not attempt to install screed extensions with only one person.

Begin with the screed lowered onto a clean flat surface.

Screed Accessories

- 1) Remove screed end gates and heat duct covers (Figure 3 - 27).

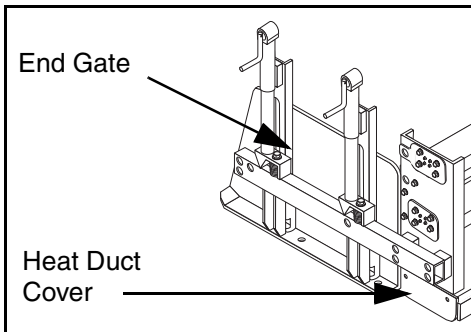

Figure 3 - 27 Preparation for Adding Extensions

- 2) Make sure all mating surfaces are clean of all asphalt, dirt, or anything that would prevent these surfaces from fitting snugly together. Pay special attention to screed bottom and strike-offs. On fuel burner models, also check the heat duct tube area.
- 3) Some screed extensions have vibrators that can be connected to the main vibrator shaft if desired. (If your unit does not have this configuration, proceed to Step 5.) When putting the extension on, you need to slip the drive line on the main screed vibrator shaft and also slip it on the extension vibrator shaft (Figure 3 - 28). Be sure to align vibrator weights in the same position as all other weights .

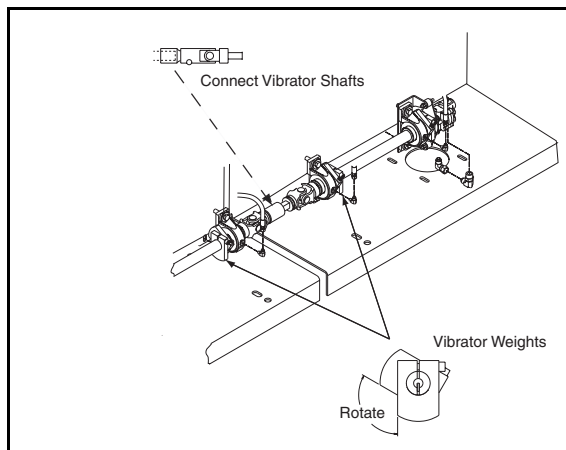

Figure 3 - 28 Vibrator Shaft Alignment

⚠ WARNING

Screed extensions are heavy. Use care to handle extensions safely. Use a hoist or several people when lifting and installing screed extensions.

- 4) Before installing extension for the first time, loosen the screed bottom retaining bolts, the horizontal press bolts and the screed sub frame tension bolts (Figure 3 - 29).

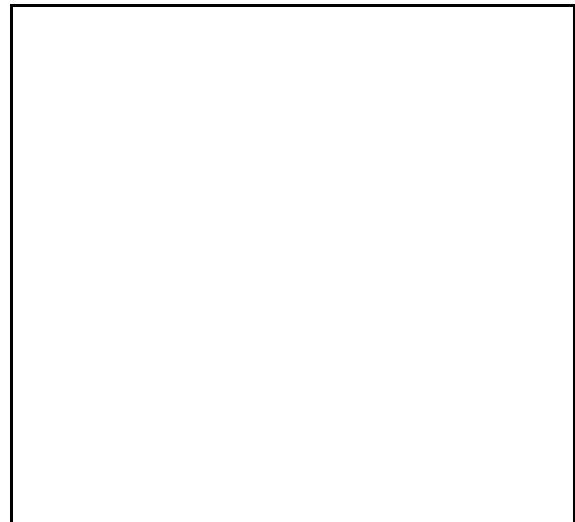

Figure 3 - 29 First Time Screed Installation

- 5) Slide extension onto end of extending screed. Put wedges into slots in each peg. Tap in securely.
- 6) Raise screed, engage screed lock and place blocking under screed.
- 7) Check to ensure screed bottom is parallel to the extending screed (Figure 3 - 30).

Screed Accessories

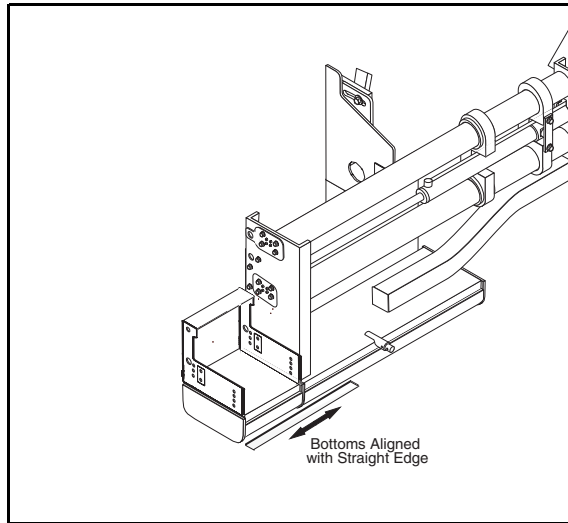

Figure 3 - 30 Checking Parallel Alignment

- 8) If screed bottom is not parallel, remove the extension and loosen the retaining nuts that hold the extension screed bottom to the sub frame (Figure 3 - 31).

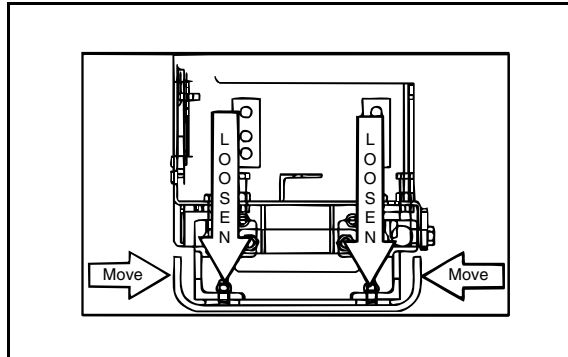

Figure 3 - 31 Aligning Extension Bottom

- 8) Reinstall extension and bump the screed bottom forward or reverse until it aligns with the extending screed. Tighten the outer screed bottom retaining nuts. Remove extension and tighten the inner screed bottom retaining nuts. Reinstall extension.
- 9) Use a straight edge to make sure screed bottoms are flush (Figure 3 - 32).

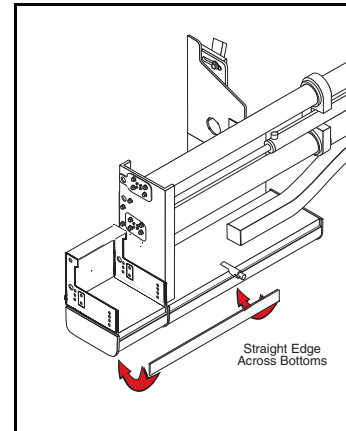

Figure 3 - 32 Aligning Bottoms Flush

- 8) If the bottoms are not flush with each other, loosen the screed bottom retaining cap screws and adjust the shim bolts until the extension screed bottom is flush with the extending screed bottom (Figure 3 - 33).

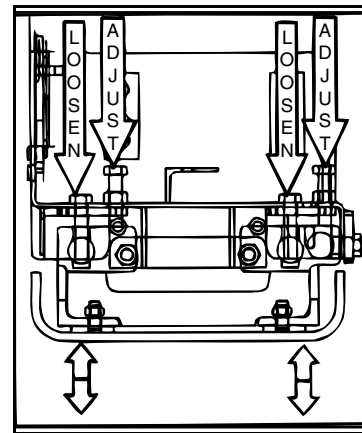

Figure 3 - 33 Adjustment Screw Locations

- 9) Tighten the screed bottom retaining cap screws and the screed sub frame screws.
- 10) Check to ensure screed fits snug against extending screed (no gap between screed bottoms). Tightening horizontal press bolts will press extension screed bottom snug against extending screed.
- 11) Install end covers and end gates.

Changing Screed Bottom

Crowning Mechanism Chain Tension

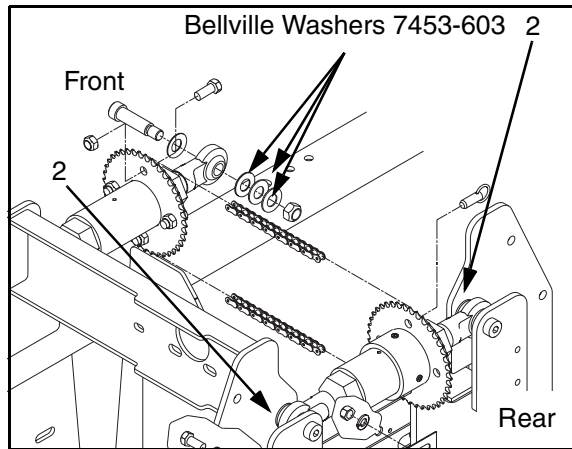

Figure 3 - 34 Bellville Washers - Location

The Bellville Washers (Figure 3 - 34) are used to adjust the chain tension as well as to adjust the alignment of the turnbuckle sprockets on the crowning mechanism. Each screed is set up with three washers on the inside rod ends of the front turnbuckle and two washers on the inside rod ends of the rear turnbuckle. Additional washers are added to adjust alignment of the chain sprockets.

Changing Screed Bottom

The screed bottoms will need to be removed from time-to-time for replacement. If the trailing edge of the screed is worn significantly more than the leading edge, the screed bottom can be removed and turned end-for-end and reinstalled to increase the screed bottom's useful life.

⚠ DANGER

Never depend on cables when working around or under raised screed. Always use blocks for additional support. Be sure blocks are free of projections that could scratch or gouge the screed bottom.

Screed Bottom Removal

- 1) Adjust lead and tail crown to zero inches (flat).
- 2) Install two 5/8" by 2" cap screws (Figure 3 - 35) into the red screed aligning plates and tighten to hold the screed frame rigid when the screed bottom is removed.

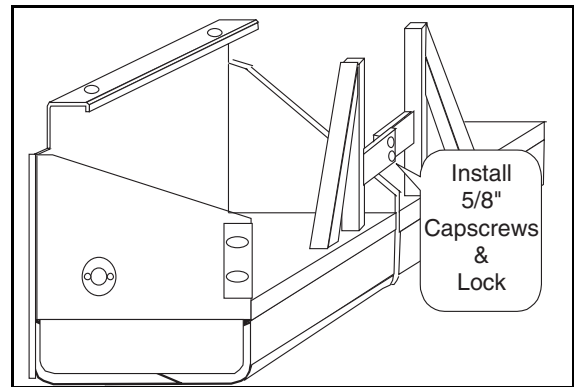

Figure 3 - 35 5/8" Cap Screws - Installation

- 3) Loosen nut on cover plate of left inside upper screed frame and rotate plate 90° as shown in Figure 3 - 35.
- 4) Install two 1/2" x 2" cap screws in two holes and tighten, locking front of the upper screed frames together (Figure 3 - 36).

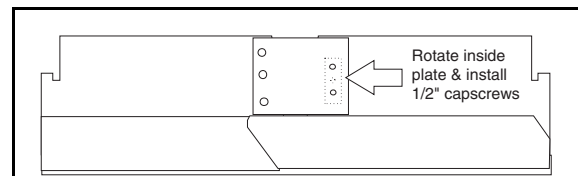

Figure 3 - 36 5/8" Cap Screws - Location

- 5) Set the screed down on a flat level area.
- 6) Remove the 3/4" retaining cap screws from rear and front of upper screed frames (eight on main screed, four per extending screed).

NOTICE

Do not loosen or attempt to adjust the shim bolts located on the main screed (Figure 3 - 37). They are set at the factory so the screed bottom when installed is parallel with the upper frames.

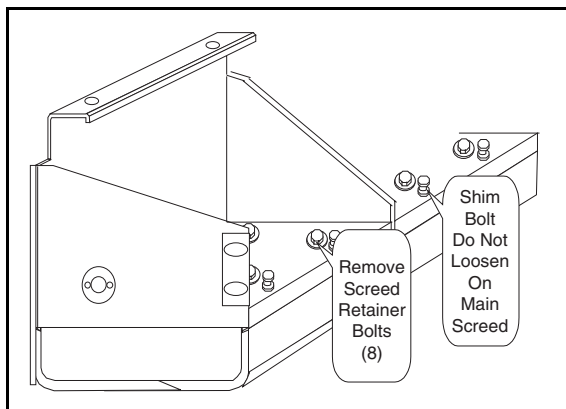

Figure 3 - 37 5/8" Shim Bolt Location

- 7) Raise the screed frames up away from the screed plate. Drive the paver forward a short distance.
- 8) Inspect and clean the back side of the fixed strike-offs of all built-up asphalt materials.
- 9) Inspect and clean out the screed heater chambers.
- 10) Measure distance from screed bottom lip to screed sub-frame at both ends of each sub-frame. (Figure 3 - 38). These measurements will be used to install sub-frames on a new screed bottom.

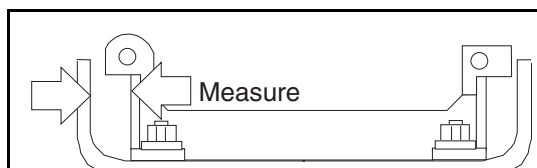

Figure 3 - 38 Sub-Frame Measurement

Changing Screed Bottom

- 11) Remove the 5/8" nuts on the rear and front of both screed sub-frames (Figure 3 - 39). Remove flat washers and lift sub-frames off old screed bottom.

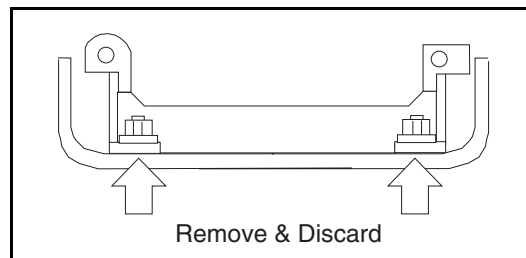

Figure 3 - 39 Sub-Frame 5/8" Nut Location

- 12) Use same series of steps to remove extending screed bottoms.

Screed Bottom Installation

- 1) Place NEW screed bottom on a flat level surface.
- 2) Place the screed sub-frames over the studs on the new screed bottom.
- 3) Place one flat washer on each stud and start NEW 5/8" lock nuts.
- 4) Measure the distance from the screed bottom lip to the sub-frame and adjust to the dimensions previously taken when removing screed bottom (Figure 3 - 40).

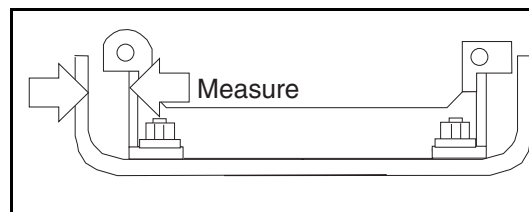

Figure 3 - 40 Reset at Original Dimensions

- 5) Tighten 5/8" lock nuts to 85 foot-pounds torque.
- 6) Position paver over screed bottom and align.

- 7) Lower upper screed frame onto screed bottom and sub-frame.
- 8) Install the eight 3/4" retaining cap screws and torque to 266 foot-pounds.

NOTICE

Do not loosen or attempt to adjust the shim bolts located on the main screed. They are set at the factory so the screed bottom when installed is parallel with the upper frames.

- 9) Use the same series of steps to install extending screed bottoms.

Cleaning Screed

It is extremely important that screed and paver be thoroughly cleaned at end of each day's operation! A spray nozzle with 30' hose is attached using a quick-disconnect to the pressure side of fuel pump. This permits operator to reach all areas of paver that require cleaning and lubricating.

WARNING

Do not operate spraydown system when screed heating system is on.

- 1) Turn main key switch ON. If extensive cleaning is required, run engine at IDLE speed.
- 2) Remove hose assembly from tool box and connect to the quick-disconnect at the screed burner control station on fuel burner models. On electric screeds, attach hose to tractor fuel pump.
- 3) Make sure all four burner fuel valves are closed (fuel burner models only).

Cleaning Screed

- 4) Turn fuel pump ON.
- 5) Fully extend rear extending screeds. Spray and clean the screed bottoms, strike-offs, and seal plate area. Periodically check for accumulation of asphalt that has spilled over extension moldboard. Spillage in this area plugs the fan air inlets and could cause the fan to shut off on fuel burner models.
- 6) Clean all parts of paver that come in contact with asphalt. Front, bogie assemblies, hopper, slat conveyors, augers, screed, etc. require cleaning at end of each day. This holds true even if paver was used only a short time. Many troubles can be traced to improper cleaning! Fuel oil on slat conveyors provide needed lubrication that prevents rapid wear. Slat conveyors should be operated during spraying to be sure chain and all slats are reached.

CAUTION

Keep oil spray away from all electrical boxes. Avoid spraying rubber hoses and cables with fuel oil as this may cause some deterioration over a period of time.

WARNING

Keep open flame, sparks, welding arcs, etc. away from screed where there are flammable materials present such as fuel oil.

Lubrication

Lubrication

General

Proper lubrication and daily cleaning are the most important factors in bearing life. Follow the recommended lubrication intervals. Be sure to clean all grease zerts and grease gun tip before greasing. During your daily cleaning and lubrication procedures, inspect the seal area for signs of a blown seal. Over-greasing or greasing when the bearings are cold is the biggest reason for blown seals.

Depth Cranks

The screed depth crank assemblies have two lubrication points on each, one on the threaded link and the other on the screed depth crank bearing housing (Figure 3 - 41). These should be lubricated every 40 hours of operation. One to two pumps from a hand grease gun is all that is necessary.

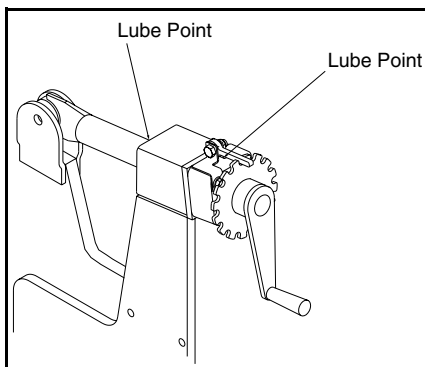

Figure 3 - 41 Depth Crank Assembly Lube Points

Vibrator Bearings

The main screed vibrator assemblies have four lubrication points, one on each vibrator bearing. The extending screed vibrator assemblies have two lubrication points, one on each bearing. All should be lubricated every eight hours of operation. One to two pumps from a hand grease gun is all that is necessary.

Match Height

The match height assemblies have two lubrication points on each, one on the threaded link and the other on the match height bearing housing. These should be lubricated every 40 hours of operation. One to two pumps from a hand grease gun is all that is necessary.

Extending Screed Slope

The extending screed slope assemblies have two lubrication points on each, one on the threaded link and the other on the slope shaft bearing housing. These should be lubricated every 40 hours of operation. One to two pumps from a hand grease gun is all that is necessary.

Crown

The crown has two lubrication points, one on each turnbuckle assembly (Figure 3 - 42). They should be lubricated every 40 hours of operation. One to two pumps from a hand grease gun is all that is necessary.

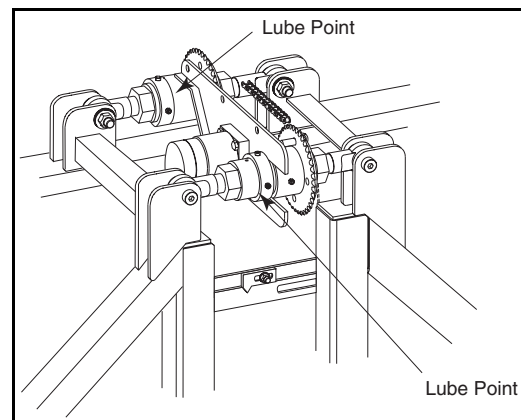

Figure 3 - 42 Crown Lubrication Points

Overview

Section 4 - Fuel Burner Operation

Overview

The purpose of the fuel burners is to raise the temperature of the screed bottom to approximately 300° F before it contacts the hot mix. This allows the material to flow under the screed bottom without sticking and produces a more uniform mat surface texture. When paving begins the burners are usually shut off. The hot mix will maintain proper screed temperature.

If material delivered to hopper has cooled too much, mat texture may be improved by running burners. When hauling long distances, it may be necessary to raise the temperature of the mix at the mixing plant to restore efficient production of a high quality mat.

Recommended temperature for material delivered to paver is 250° F minimum when medium or high penetration asphalt is used. For low penetration asphalt a minimum of 300° F is required. Many mat defects are results of incorrect material temperature at the time of paving.

Usually the screed bottom will be heated sufficiently by running burners for 15 to 20 minutes before operation. However, the screed may require 30 to 60 minutes to preheat depending on ambient temperature, wind conditions and thickness of screed bottom.

When screed is hot enough, turn burner fuel valve(s) OFF but leave fan(s) ON for at least 5 minutes to dissipate excess heat.

Summary of Burner Operations

The sequence for burner operation is outlined below. Refer to the burner control panel (Figure 4 - 1) and step-by-step instructions in the pages that follow

- 1) Start the burners.
- 2) Run the burners for 10 to 20 minutes. Make sure the screed bottom does not overheat.
- 3) Turn the burner fuel off while the fans continue to run to dissipate the heat concentrated directly below the burner outlets.
- 4) Turn off the fans and restart the burners as needed until the entire screed bottom is up to temperature.

CAUTION

Excessive heat can cause screed bottom to warp. Never heat above 350° F!

CAUTION

Pay close attention to the area of the screed bottom directly under the burner while preheating the screed. This area will warm up quicker than the rest of the screed and could overheat if not watched closely.

Control Panel

Control Panel

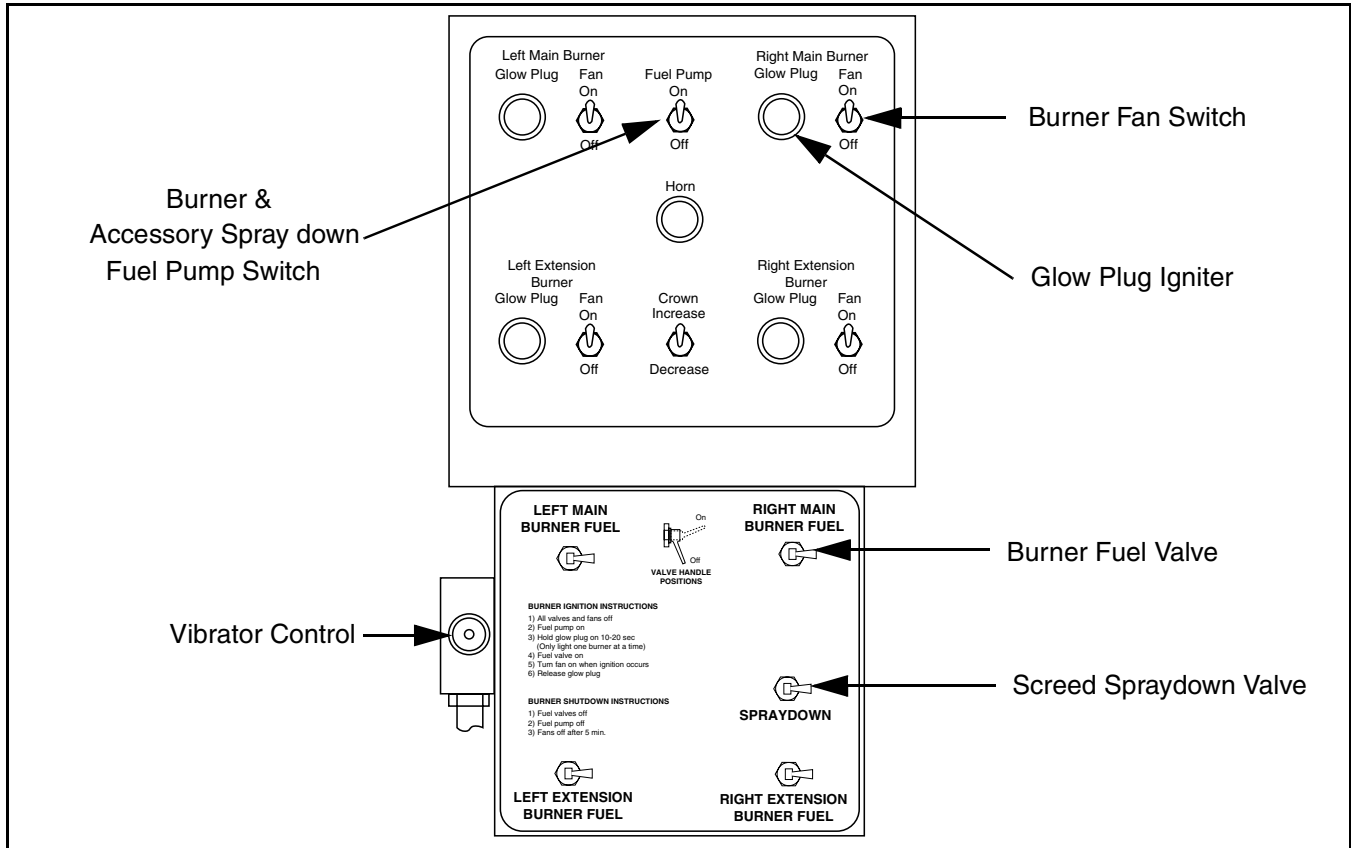

Figure 4 - 1 Burner/Fuel/Vibrator Control Panel

Burner/Fuel/Vibrator Control Panel

The tractor main keyswitch must be ON before any of the following controls will function.

Burner Fuel Pump Switch - This switch controls the fuel pump mounted on the front right side of the tractor. The fuel pump supplies fuel to the screeds burners and to the spraydown valves on the screed and right side of the tractor.

Vibrator Control - This dial controls the speed or frequency of the screed vibrators. Rotate the dial clockwise to increase the Vibrations Per Second (VPM) or counterclockwise to decrease the VPM.

Burner Fan Switch - Controls the burner fan. Always let the fan run for five minutes after the burner fuel has been turned off.

Glow Plug Igniter - Hold this button down for ten to twenty seconds before opening the burner fuel valve.

Burner Fuel Valve - Controls flow of fuel to the individual burners.

Screed Spraydown Valve - Controls flow of fuel to the screed spraydown connector mounted behind the screed fuel control panel.

Control Panel

Operating Screed Burners

Burner ignition sequence is as follows; the sequence is also provided on burner control panel (Figure 4 - 1).

- 1) Make sure all valves and fans are OFF.
- 2) Turn fuel pump switch ON.
- 3) Hold GLOW PLUG button in for approximately 10-20 seconds and then turn ON the appropriate burner fuel valve.

CAUTION

Only ONE glow plug igniter should be pressed at a time. Holding down more than one glow plug igniter could overload the 60-watt glow plug circuit breaker.

- 4) When ignition occurs, turn fan ON and release GLOW PLUG switch.
- 5) Set air damper 1/4 of the way open and visually inspect flame. Adjust air damper to obtain the cleanest possible flame. Presence of smoke indicates the air damper requires adjustment.
- 6) Repeat this procedure for all of the burners.
- 7) After screed bottom reaches desired temperature, turn off fuel valves and pump. Allow fans to run for five minutes to dissipate heat.

CAUTION

DO NOT overheat. A temperature of 350° F can cause warping which will affect mat quality and make settings and adjustments difficult.

NOTICE

Always preheat all of the screed sections. If paving at ten feet wide it is necessary to preheat both the main and rear screed sections.

CAUTION

The burners must be turned off before paving begins. Running the heaters while paving could burn the mat or create a hot spot on the screed bottom.

Burner Shut-off Sequence

- 1) Shut off fuel valves.
- 2) Turn off fuel pump.
- 3) Allow fans to run at least five minutes to dissipate excess heat.
- 4) Shut off fans.

CAUTION

Failure to run the burner fan after the burner has been turned off could damage the screed bottom.

Burner Maintenance

A screwdriver and hammer are needed to disassemble burner from heat tube. The blower and heat tube are tightly clamped together by a heavy spring. Releasing this spring and turning the latches frees the burner for nozzle inspection, fuel flow check, damper check, or glow plug inspection. Simply reverse procedure to reassemble.

The burner nozzles have a special fine filter at their inlet end. In case of plugging problems, the nozzle should be removed from the affected burner. Start the fuel pump and open the burner fuel control valve to purge contamination from the line into a container. The nozzle filter can be unscrewed and gently blown out with compressed air. The nozzle head itself can also be disassembled and cleaned.

The wire to the glow plug should be threaded through the stand-offs provided to prevent it from contacting the burner tube, melting the insulation.

Overview

Section 5 - Electric Screed Operation

Overview

The Stretch 16 and 18 electric screeds provide thermostatically controlled, electric heat to the screed bottom, eliminating the need for fuel burners. The electric heat is evenly distributed across the bottom grid. This allows the material to flow under the screed bottom without sticking and produces a more uniform mat surface texture.

Stretch Electric Screed Controls

Stretch Electric Screed Controls

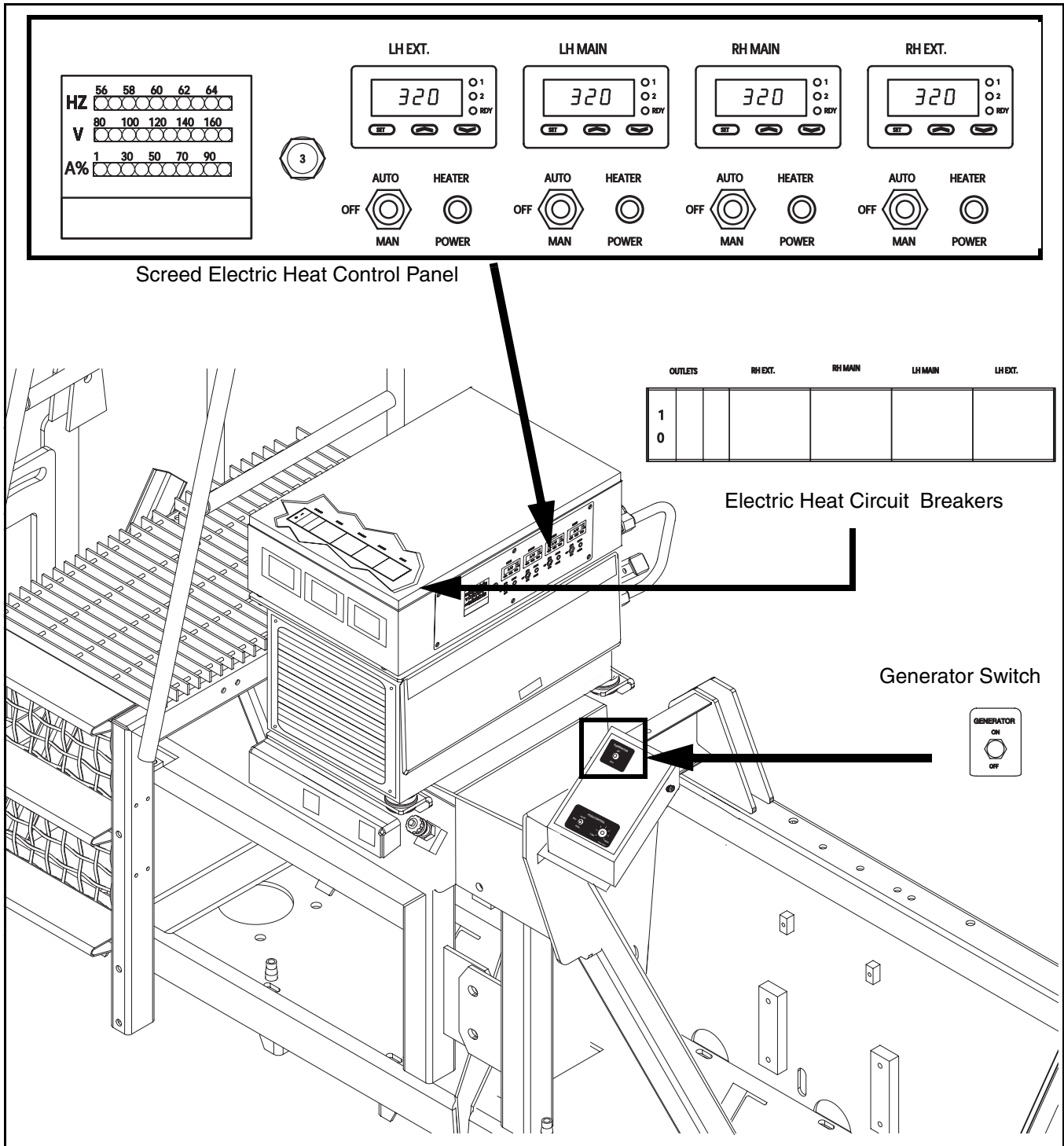

Figure 5 - 1 Electric Screed Controls

Control Panel Functions

Control Panel Functions

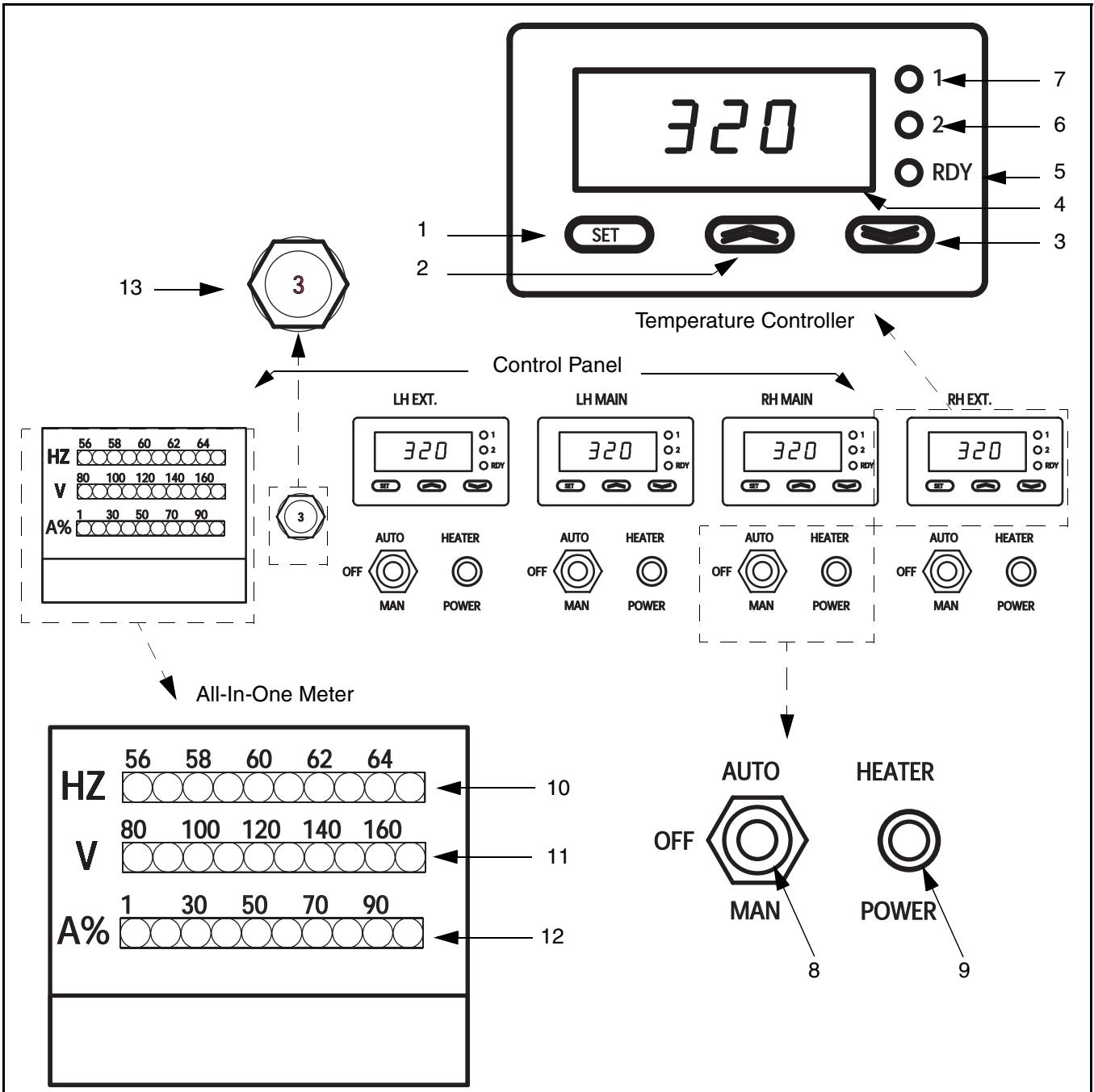

Figure 5 - 2 Electric Screed Control Panel

The Stretch 16 and 18 electric screed control panels are designed to provide ease of operation and the ability to monitor and control the heating of the screed electrical components.

The function of each control is outlined below:

Temperature Controllers

The control panel has four individual temperature controllers, one for each section of the screed. Each controller unit contains components to allow setting and monitoring of temperature adjustment for the corresponding screed section.

1) Temperature Controller Set Button

Indicates screed section temperature set point when the button is depressed. Used in conjunction with either the Temperature Up (see #2, below) or Temperature Down (see #3, below) buttons to adjust the temperature settings of the respective screed section. When a set button is released, controller reads the actual screed section temperature.

2) Temperature Up Button

With the Set button depressed, pushing the Temperature Up button raises the temperature set point of the respective screed section.

3) Temperature Down Button

Pushing the Temperature Down button lowers the temperature set point of the respective screed section with the set button depressed.

4) Temperature Controller Display

The Temperature Controller Display is a digital display meter which shows either the actual temperature or the temperature set point

Control Panel Functions

of the respective screed section depending upon whether the set button is depressed or released.

5) Temperature Controller Ready Light

Non-functional Light Emitting Diode (LED) indicator.

6) Temperature Controller #2 Light

LED indicator illuminates when actual screed section temperature is *lower* than the set point. LED light goes out when temperature reaches set point.

7) Temperature Controller #1 Light

Non-functional LED indicator.

Section Controllers

8) Screed Section Control Switch

A three-position switch that controls electrical power to each screed section temperature controller. When switch is toggled to the AUTO position, it automatically activates the temperature controller for the respective section of the screed. Placing the switch in the MAN position by-passes the automatic temperature controls and allows manual powering of the screed heating element for the selected section.

9) Screed Section Heater Power Indicator

LED indicator comes on when screed section heater has electrical power running through it.

Stretch Electric Screed Operation

All-In-One Meter

The all-in-one meter on the control panel gives a general visual reading of the generator output. LED indicators will light to display generator output status.

10) All-In-One Meter Frequency

LED indicators which come on to indicate the generator's electrical frequency output. Normal frequency should be 58 - 62 Hz.

11) All-In-One Meter Voltage

LED indicators that identify the voltage output for the generator. Normal voltage should be 110 - 130 Volts DC.

12) All-In-One Meter Amperage

LED indicators that identify the output amperage for the generator. The LEDs will go on or off depending on the load as each screed section is powered up or down. With all screed sections heating, the amperage will be @ 50 Amps.

Circuit Breakers

13) Screed Control Panel Circuit Breaker

Circuit breaker that provides protection for screed control panel components.

Stretch Electric Screed Operation

Perform the following to operate the Stretch electric screed:

- 1) Start engine and run at 1400 rpm until engine and hydraulic fluid are warm.

NOTICE

Make sure generator switch and all screed section control switches are OFF.

- 2) Turn generator switch ON (Figure 5 - 1).
- 3) Turn each screed section control switch to AUTO (Figure 5 - 2).

NOTICE

If screed section heater power indicators (Figure 5 - 2) do not light, check circuit breakers inside of control box (Figure 5 - 1).

- 4) Press set button on temperature controller and, with it depressed, press either the up or down button to adjust that section's set point. Recommended set point is 180° - 240° F.
- 5) Release set button. Temperature display should now read actual screed section temperature.
- 6) Repeat for each screed section.
- 7) Wait until all screed sections reach temperature set point before starting paving operation.

Screed Generator Pump Set-Up

Screed Generator Pump Set-Up

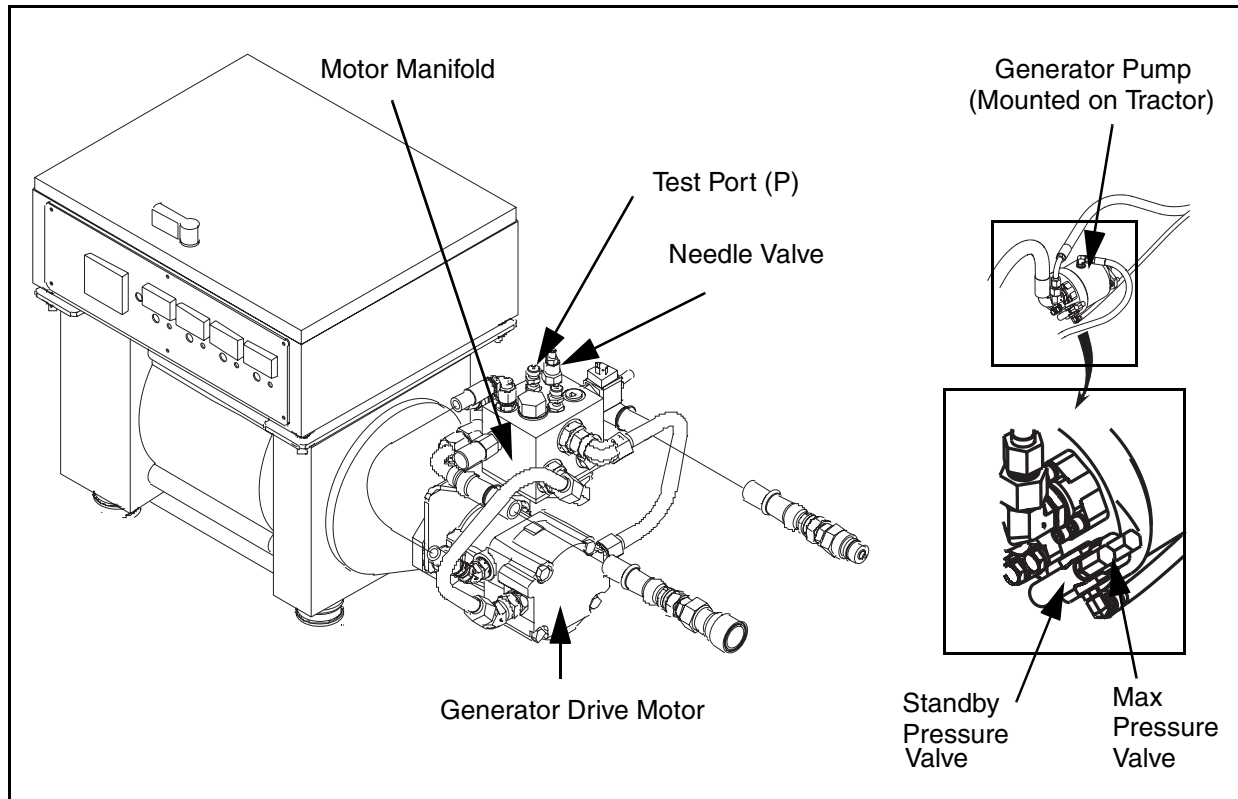

Figure 5 - 3 Stretch 16 & 18 Screed Generator Hydraulic Pump Assembly

To properly operate the screed electric heating units, it is necessary to set up the screed generator pump circuit.

This hydraulic pump circuit has three valves which require adjustment: the needle valve (located on the drive motor manifold), the pump standby pressure adjustment screw and the maximum pressure valves, both located on the pump (Figure 5 - 3).

Start-up After Initial Installation of Pump

- 1) Fill pump housing with clean oil. Do this through the case drain port on the pump housing.
- 2) Loosen needle valve jam nut on screed generator drive motor manifold.
- 3) Turn screw clockwise until it bottoms to fully close valve.
- 4) Start engine and run at idle.
- 5) Turn generator switch on and let run with engine at idle approximately one (1) minute to prime pump and purge air from lines. Generator should turn at a low speed.
- 6) Turn generator switch off.
- 7) Shut off engine.

CAUTION

Do not apply electrical load to generator.

Screed Generator Pump Set-Up

Set Pump Max Pressure

- 1) Start engine and run at 1400 rpm.

NOTICE

Make sure generator switch is turned OFF.

- 2) Install 6000 psi gauge on test port (P) of generator drive motor manifold. (Figure 5 - 3)
- 3) Remove cap from standby pressure adjustment screw and loosen jam nut.
- 4) Turn standby pressure adjustment screw clockwise until it bottoms to fully seat valve.
- 5) Note gauge pressure. Pressure will be approximately 500 - 2500 psi.
- 6) Remove cap from max pressure adjustment screw and loosen jam nut.
- 7) Turn max pressure adjustment screw clockwise until gauge reads 4000 psi.
- 8) Tighten jam nut on max pressure adjustment screw and reinstall cap.

Set Pump Standby Pressure

- 1) With engine still running at 1400 rpm as described above, turn standby pressure adjustment screw counter-clockwise until gauge reads approximately 400 psi.

NOTICE

Make sure generator switch is turned OFF.

- 2) Shut off engine.

- 3) Remove 6000 psi gauge and install 1000 psi gauge.
- 4) Re-start engine and run at 1400 rpm.
- 5) Re-check pressure to make sure standby pressure reads 400 psi. Adjust if necessary.
- 6) Tighten jam nut on standby pressure adjustment screw and reinstall cap.
- 7) Shut off engine.

Set Generator Motor Speed (Frequency)

- 1) Install a frequency (Hz) test meter into the 120-volt outlet on the generator control box (Figure 5 - 4).
- 2) Start engine and run at 1400 rpm.
- 3) Turn generator switch on.
- 4) Turn needle valve screw counter-clockwise until test meter reads 62 Hz.
- 5) Tighten jam nut on needle valve.
- 6) Shut off engine.

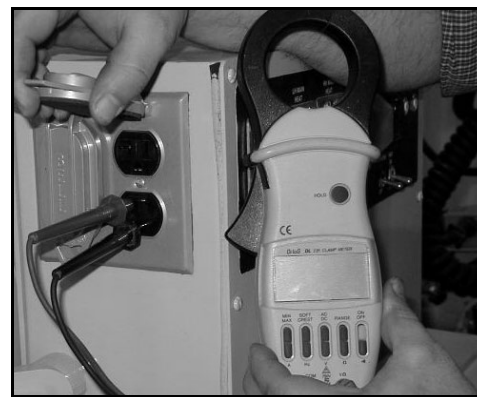

Figure 5 - 4 Setting Generator Frequency

The screed generator pump and hydraulics are now ready to be put into operation.

Tractor Generator Plumbing

Tractor Generator Plumbing

Adding or removing the electric screed from the tractor will require changes to the tractor generator pump plumbing configuration.

CAUTION

Make sure generator pump plumbing is properly connected prior to operation.

Attaching Screed To Tractor Generator Pump

When the screed is attached to the tractor, the generator pump load sensor line is connected to the quick connect fitting on the screed's generator drive hydraulic motor (Figure 5 - 5).

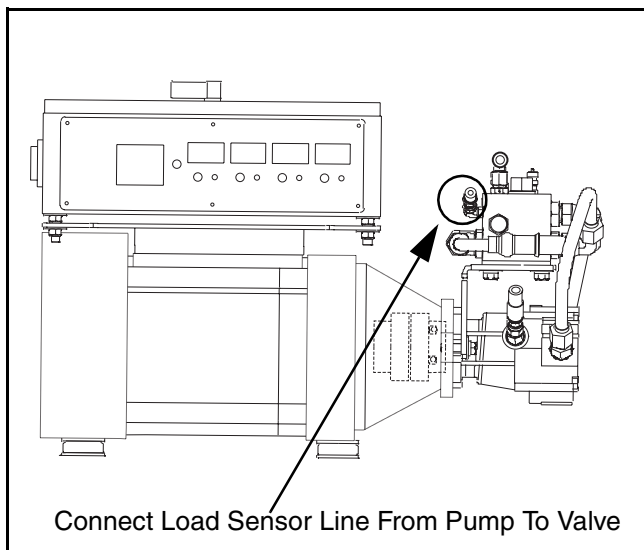

Figure 5 - 5 Tractor Generator Pump Connection on Screed Generator Drive Motor

Operating Tractor Pump Without Screed

Removing the screed from tractor requires disconnecting the generator pump load sensor line from the screed's generator drive motor. The line is then rerouted to the pump by attaching it to the 1/4" nipple on the rear of the tractor (Figure 5 - 6).

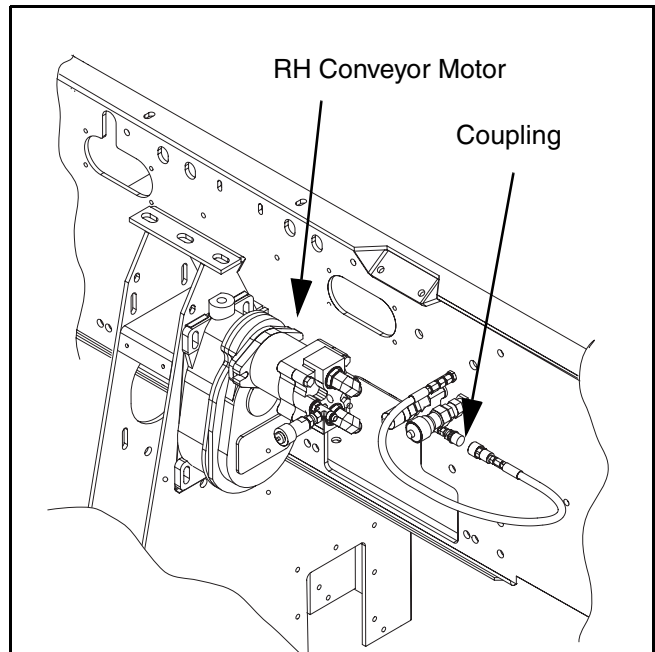

Figure 5 - 6 Generator Pump Connections for Detached Screed

Appendix A - Schematics

Hydraulic & Electrical Schematics

The following pages contain hydraulic and electrical schematics for the Stretch 16, 18 and Stretch 20 electric screeds (schematics for the 16 and 18 models are identical). Refer to schematics for troubleshooting or for making repairs.

Hydraulic & Electrical Schematics

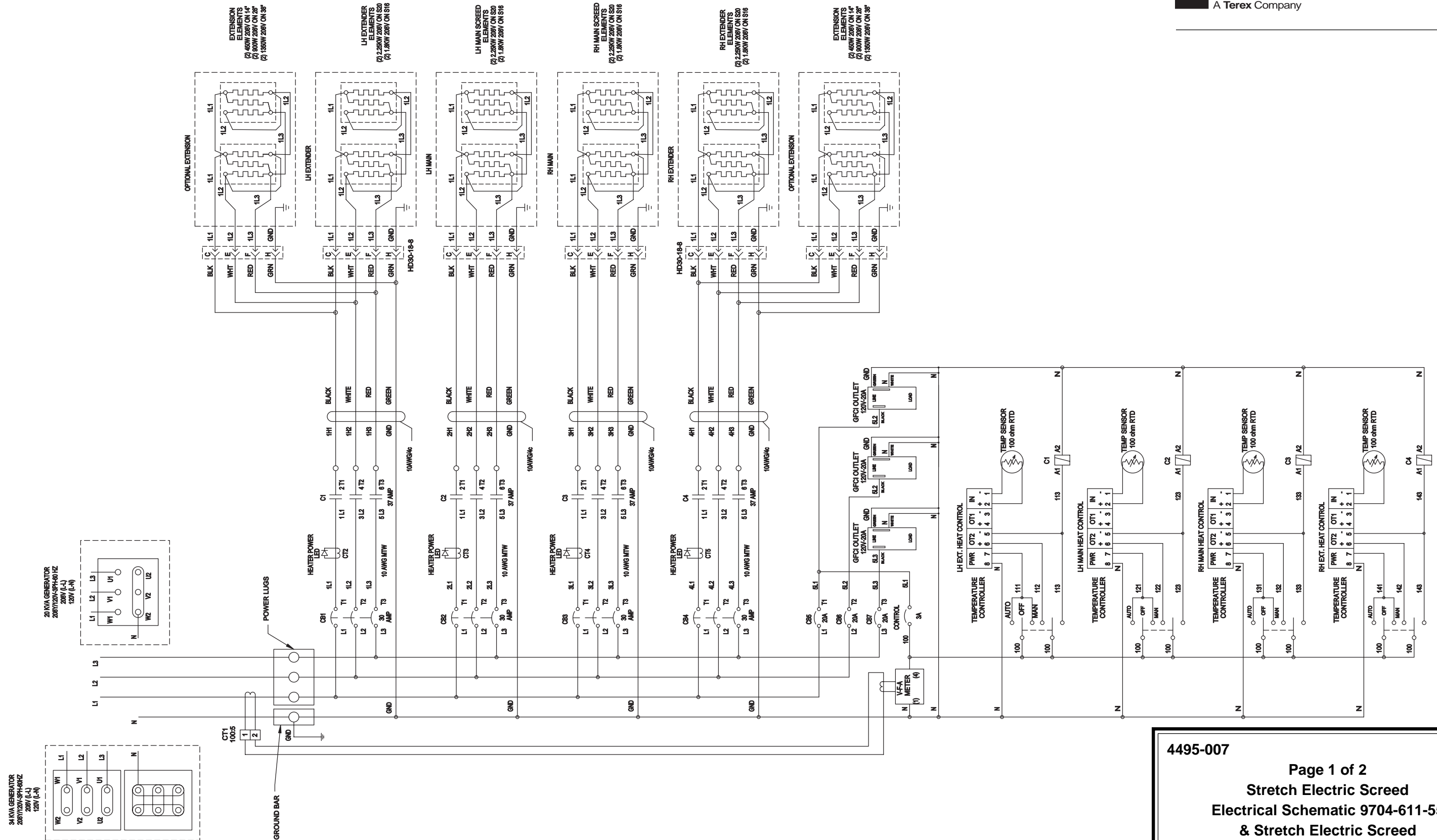

4495-007

Page 1 of 2

**Stretch Electric Screeed
Electrical Schematic 9704-611-55
& Stretch Electric Screeed
Hydraulic Schematics
9704-662-58 Stretch 16
9704-662-56 Stretch 20
Cedarapids Inc.**

7/02

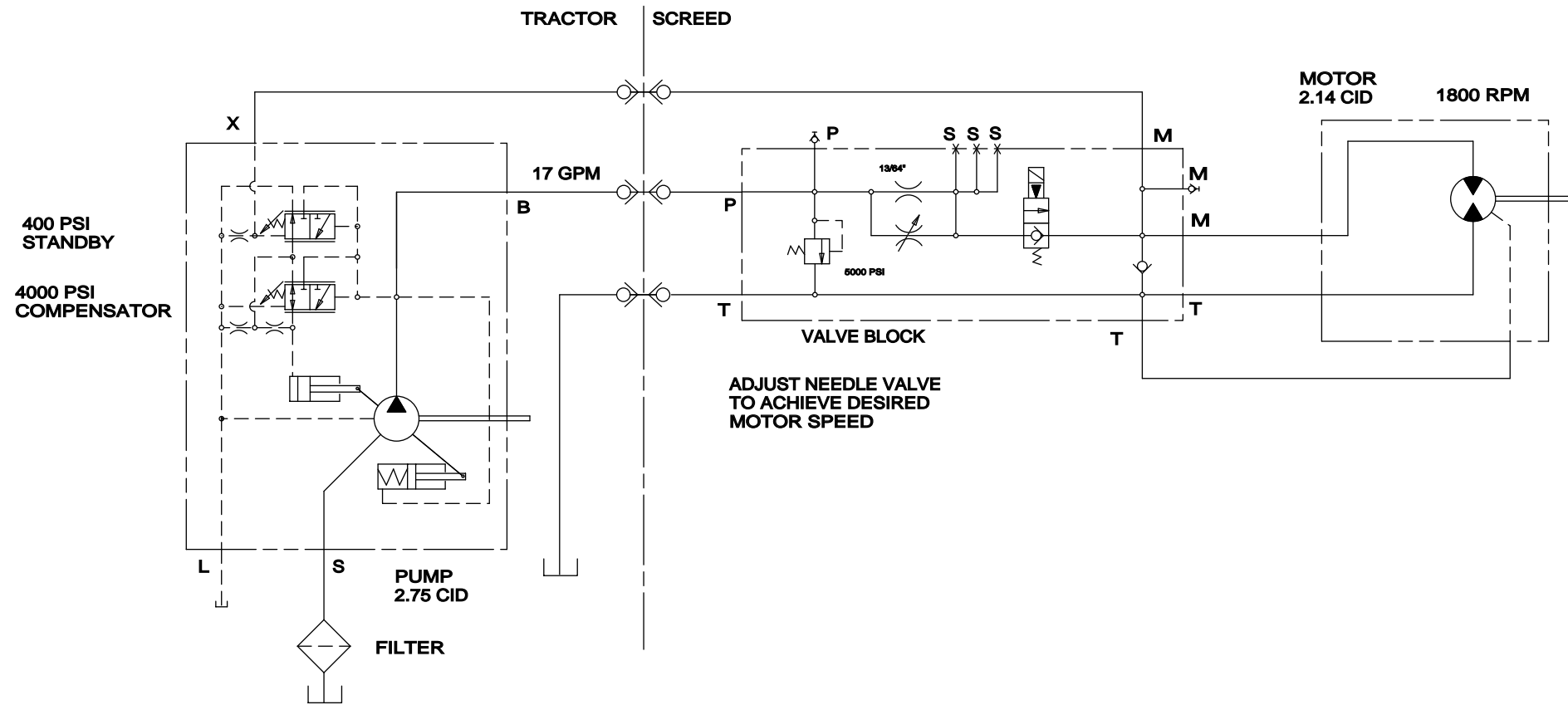

Stretch 16

PUT JUMPER HOSE BETWEEN PORTS
M2 AND X ON PUMP

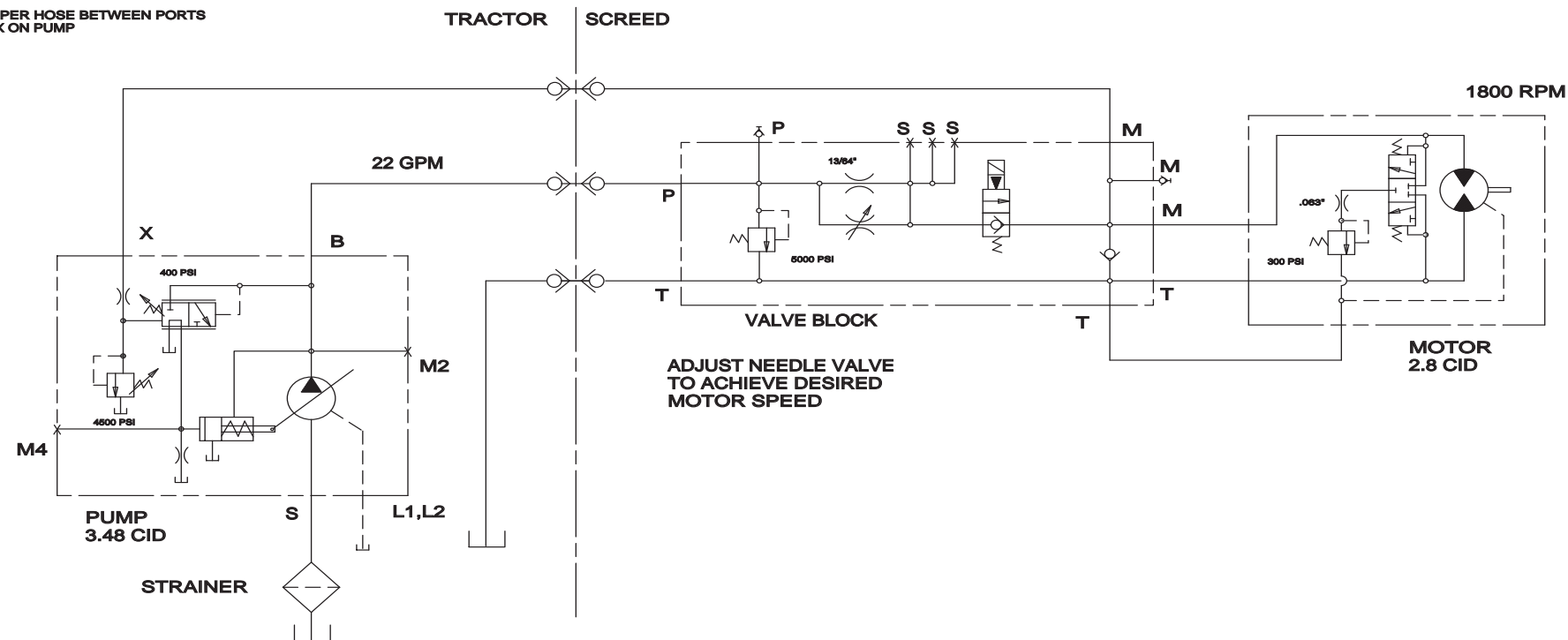

Stretch 20