Topcon Corporation

**System 5 & Smoothtrac®
Operator's Manual
7010-0341 Rev. D**

TEREX 
Cedarapids



EQUIPMENT AUTOMATION: PAVER

TOPCON



Paver

System 5 & Smoothtrac®

Operator's Manual

Tracker II

© 2002 TOPCON Positioning Systems, Inc. All rights reserved. No part of this manual may be reproduced in any form or by any means without prior written permission from:

TOPCON Positioning Systems, Inc.

Warranty

TOPCON Limited Warranty

Electronic and Mechanical Components

TOPCON warrants that the electronic components manufactured by TOPCON shall be free of defects in materials and workmanship for a period of one year from the original date of shipment to the dealer. TOPCON warrants that all valves, hoses, cables and mechanical parts manufactured by TOPCON shall be free of defects in materials and workmanship for a period of 90 days from the date of installation.

Return and Repair

During the respective warranty periods, any of the above items found defective may be shipped to TOPCON for repair. TOPCON will promptly repair the defective item at no charge, and ship it back to you. Calibration of components, labor and travel expenses incurred for in-field removal and replacement of components are not covered under this warranty policy. Damage to components due to negligence, abuse or improper use is NOT covered under this warranty.

Warranty Disclaimer

The above warranties are in lieu of all other warranties, whether expressed or implied, including all warranties or merchantability, or fitness for a particular purpose. In no event will Topcon Positioning Systems, Inc. or its Representative be liable for lost profits or other consequential damages arising from the purchase or use of TOPCON's

components or any performance hereunder or any claims of negligence, even if TOPCON has been advised of the possibility of such damages.

Service assistance can be provided by contacting your local **TOPCON** dealer or by calling the **Corporate Service Center**.

Travel charges will be applied for any on-site service whether warranty or non-warranty in nature.

Phone: (866) 4-TOPCON - (866-486-7866)
8 a.m. to 5 p.m. Pacific Time
Monday through Friday

FAX: (925) 460-1329



Foreword

TOPCON Positioning Systems, Inc.™ produces productivity enhancement tools engineered and manufactured by professionals from the construction industry. The efficient design and advanced technology of TOPCON Positioning Systems™ System Five™ allows you to increase production, effectively control materials, and reduce time spent setting and checking grade.

This manual has been developed to provide the paver operator with information necessary to operate and maintain TOPCON System Five™. Proper service and use is important to the reliable operation of the equipment. The procedures described herein are effective methods for performing service and operation of this system.

The sections provided in this manual include information necessary for the correct operation care and troubleshooting of your TOPCON System Five™. Also contained in this manual is a selection of **WARNINGS**, **CAUTIONS**, and *NOTICES* you should become familiar with in order to safely operate the system.

Each symbol represents a particular level of danger:



WARNING

Represents a procedure or operation that, if not strictly followed, can cause serious damage to the equipment, and/or serious injury or death to the person performing the operation.



CAUTION

Represents a procedure or operation that, if not followed correctly, can result in serious damage to the equipment or personal injury.



NOTICE

Represents a procedure that, if not performed correctly, can adversely effect the performance of the equipment.

Please study this manual carefully. The benefits this product provides can be greatly influenced by your applications knowledge.

All information, illustrations, and applications contained herein are based on the latest available information at the time of publication. TOPCON reserves the right to make product changes at any time without notice.

Comments, suggestions, and questions about TOPCON products are welcomed. Contact your local TOPCON representative or a representative at our corporate facility.

TOPCON POSITIONING SYSTEM, Inc.

5758 W. Las Positas Blvd.
Pleasanton, CA 94588
925 / 460 1300
925 / 460 1315 FAX



Table of Contents

Warranty	W-1
Limited Warranty	W-1
Electronic and Mechanical Components	W-1
Return and Repair	W-1
Warranty Disclaimer	W-1
Foreword	F-1
Table of Contents	TOC-1
Safety Information	S-1
General Precautions	S-1
Chapter 1: System Overview	1-1
Paver Illustration	1-2
Control Box	1-3
LCD	2-3
Light Sensor for LCD	2-3
Power Switch	2-3
Grade Adjustment Knob	2-4
Grade Adjustment Arrows	2-5
Grade Adjustment LED	2-6
Set/Menu Button	2-7
Slope/Elevation Button	2-8
Survey/Indicate Button	2-9
Auto/Manual Button	2-10
Jog Switch	2-11
Sonic Tracker II™	1-4
Slope Sensor	1-5
Smoothtrac® Sonic Averaging System (SAS)	1-6
Laser Tracker & Trackerjack	1-7
Carrying Case	1-8

Chapter 2: Operation	2-1
Control Box	2-1
Control Box Frt Pnl Switches and Controls	2-2
Other Control Box Components	2-12
Sonic Tracker II	2-13
Working Window	2-15
Slope Control	2-27
Performance Menu	3-1
Control Box Memory	3-1
Accessing Menu Settings	3-1
Gain (Elevation)	3-5
Gain (Slope Control)	3-7
Valve Offset	3-9
Averaging	3-12
Deadband Elevation	3-14
Deadband Slope	3-16
Beeper Alarm	3-18
Unit	3-19
Test	3-21
Principles of Paving	4-1
Paver Components	4-1
How a Screed Works	4-2
Tow Point Force	4-6
Truck Exchange	4-7
"M" Head of Material	4-8
"R" Reaction of Material Under Screed	4-10
Mix Characteristics	4-11
Gradation	4-11
Mix Temperature	4-13
"W" Weight of Screed	4-14
Quality of Base Being Paved	4-15
Rolling Techniques	4-16
Controlling Mat Quality	4-16

Getting Ready to Pave	5-1
Machine Setup	5-2
Sonic Tracker Setup	5-5
Control Box Setup - Elevation	5-6
Control Box Setup - Cross Slope	5-11
Tracker Placement	6-1
Stringline	7-1
Setting Surface Stringline	7-1
Setting Elevated Stringline	7-5
Making a Grade Verification Lath	7-13
Verifying Grade	7-14
Smoothtrac® (SAS) Set Up	8-1
Positioning the SAS	8-5
Placement of Sonic Averaging System	8-9
Applications	9-1
Paving City Streets with Sonics	9-1
Paving City Streets with Cross Slope	8-9
Paving Streets Through Intersections	9-7
Method 1	9-7
Method 2	9-10
Paving Intersections with Cross Slope	9-11
Maintenance	10-1
Preventative Maintenance & Daily Care	10-1
Transducer Cleaning	10-3
Transducer Replacement Procedure	10-4
Troubleshooting	11-1
Control Box Symptoms	11-1
Tracker Symptoms	11-13
Slope Sensor Symptoms	11-17
SAS Symptoms	11-21
Appendix	A-1

Safety Information

It is your responsibility to be completely familiar with the cautions described in this System Five™ Manual. These messages advise against the use of specific methods or procedures which can result in personal injury, damage to the equipment, or unsafe operating conditions. Remember, most accidents are caused by failure to observe basic safety precautions.

General Precautions

1. Read and become familiar with the paver manufacturer's operations manual, including safety information before installing or using your TOPCON System Five™.
2. Use extreme caution on the jobsite. Working around heavy construction equipment can be dangerous.
3. System Five is externally mounted on the paving machine. DO NOT install the system while the paver is running.
4. DO NOT allow any System Five™ component to limit the visibility of the operator or protrude into traffic.
5. Use Ty-Wraps supplied with System Five™ to keep hoses and wires secured and away from possible wear or pinch points.

6. Use eye protection when welding, cutting or grinding is being done on the machine.
7. Protect yourself at all times and wear protective clothing when working on or near hydraulic lines. Hydraulic lines can be under extreme pressure even when the machine is turned off.



WARNING

Relieve all pressure in the hydraulic lines before disconnecting or removing any lines, fittings or related components. If injury does occur, seek medical assistance immediately.

8. Avoid direct exposure to your eyes when using laser control.



CAUTION

DO NOT stare into the laser beam or view the beam directly with optical equipment.

9. Use appropriate welding precautions and practices when welding.

After welding, all affected areas should be painted with a rust inhibitor.



NOTICE

Disconnect all TOPCON system electrical cables prior to welding on the machine.



WARNING

Do not weld near hydraulic lines or on any equipment when in operation.



NOTICE

All mounting bracket welds must be secure and strong to prevent the sensor equipment from vibrating excessively or from becoming detached at the weld during operation.



NOTICE

Keep the Carrying Case dry at all times. DO NOT allow moisture to get inside the case. Moisture trapped in the case can adversely affect components.

If moisture does enter the Carrying Case, leave it open and allow it to thoroughly dry before storing any components.

- 10.** To prevent vandalism or theft, do not leave the removable TOPCON components (Control Boxes, Sonic Tracker IIs™ and cables) on the machine at night. Remove the components each evening and store appropriately in the Carrying Case.

System Overview

System Five™ is a complete, non-contacting control system which combines both elevation control and slope control into a simple, easy to use package. A standard system includes two (2) Control Boxes, two (2) Sonic Tracker II™'s and a single (1) Slope Sensor. The Control Box on the right side of the machine controls the right side for either elevation or slope. Likewise, the left Control Box controls the left side for either elevation or slope.

The primary function of System Five™ is to provide screed control so that the paving material is placed into position at the correct elevation and slope.

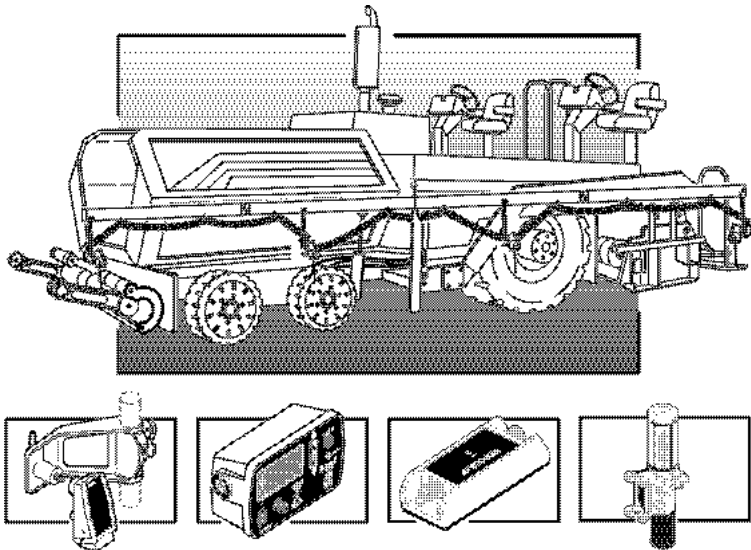

Figure 1.01

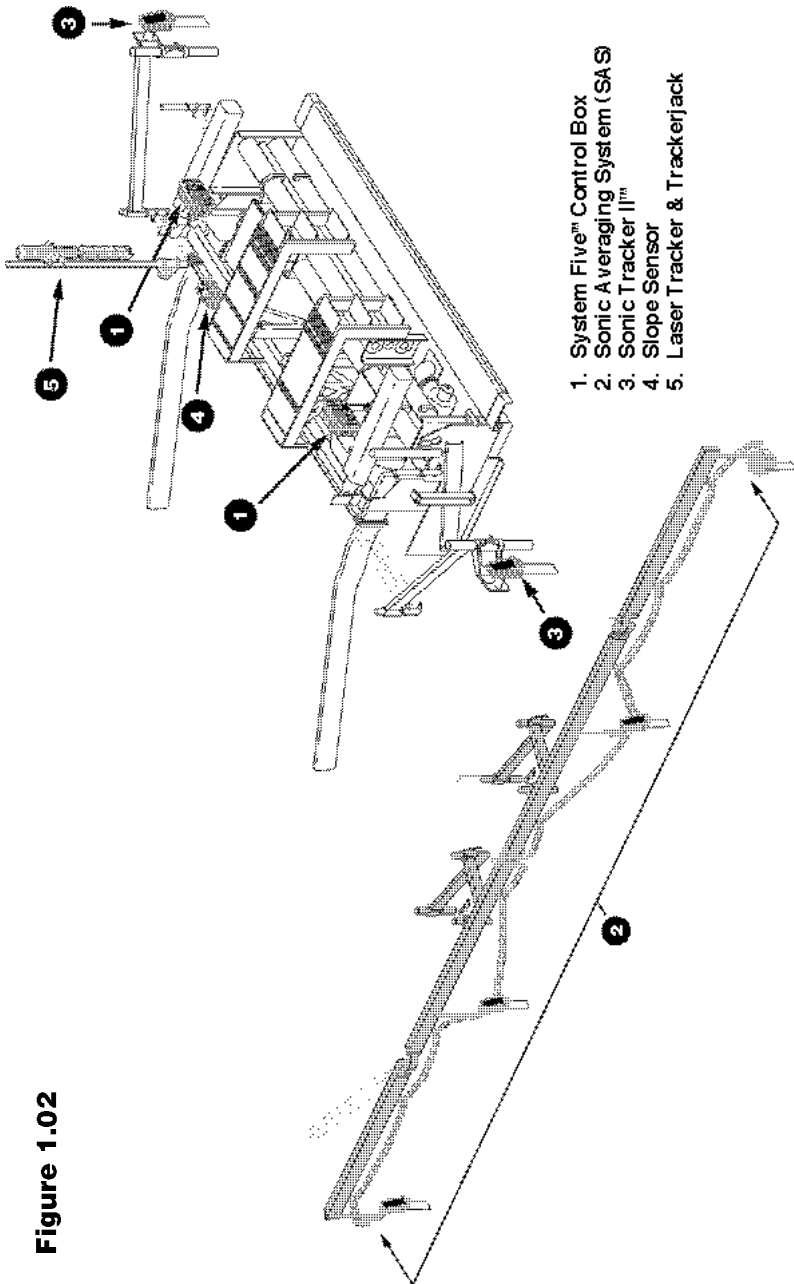

Figure 1.02

Control Box

The Control Box is the operator's interface to System Five™. The Control Box receives signals from the sensors, (Sonic Tracker II™, Laser Tracker and/or Slope Sensor), and uses these signals to determine if grade or slope corrections are necessary. If a change in grade or slope is required, the Control Box sends a signal to the valve controlling the tow point cylinder on the appropriate side of the machine to raise or lower, thus maintaining correct mat thickness.

The Control Box easily attaches to its mounting bracket with one clamp, and at the end of the day should be removed for storage. The Control Box connects to the Sonic Tracker II™, the Slope Sensor, and to the paver through electrical cables.

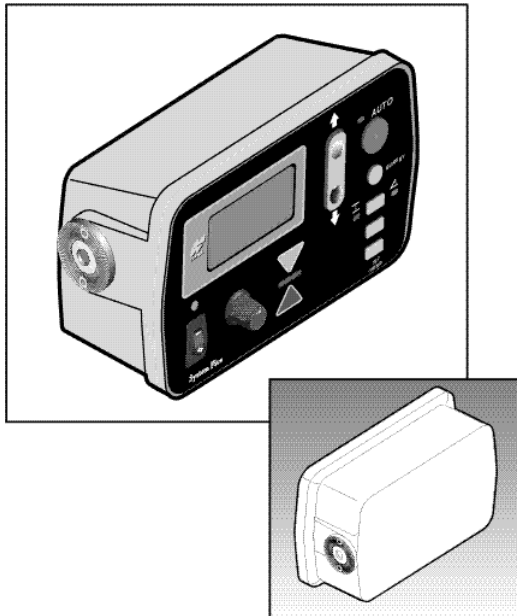

Figure 1.03

Sonic Tracker II™

The Sonic Tracker II™ measures and controls the elevations of the screed. A transducer, located in the bottom of the Sonic Tracker II™, generates sound pulses like a speaker and listens for returned echoes like a microphone. The Tracker measures the distance, and controls grade from a physical grade reference, such as a curb, stringline, or existing road surface. A bail is used to compensate for rapid air temperature changes. In paving applications a bail should always be used.

The Sonic Tracker II™ attaches to the system through one quick connect cable and attaches to the machine with a single bolt. At the end of the day, Sonic Tracker II™ should be removed for proper storage in the carrying case.

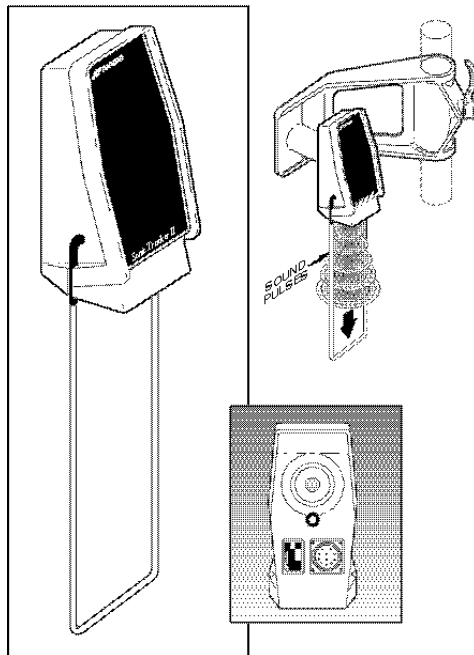

Figure 1.04

Slope Sensor

The Slope Sensor is a precision electronic sensor which functions much like a precision carpenter's level. The Slope Sensor reads the inclination (tilt) of the screed and sends the signal to the Control Box.

The Slope Sensor will measure slopes from +20% to -20%.

The Slope Sensor is a sealed unit and contains no adjustments. It is the only component of System Five™ which may be selected to control either side of the paver. It is connected to each Control Box through an electrical cable. The Slope Sensor is a sealed component and once attached to the paver should not be removed.

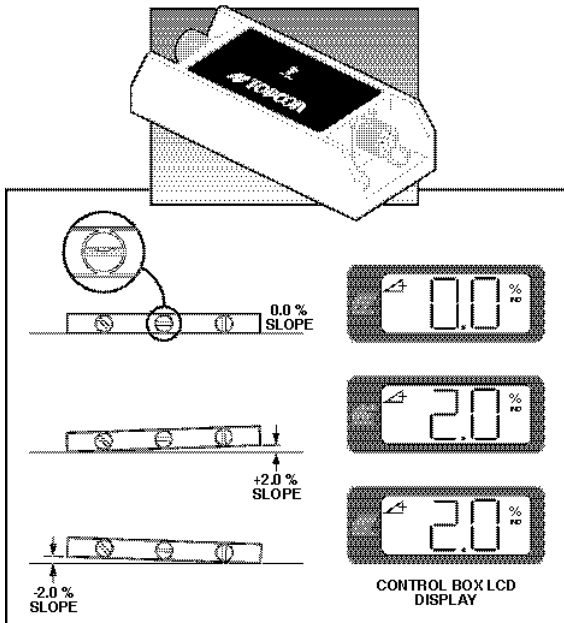
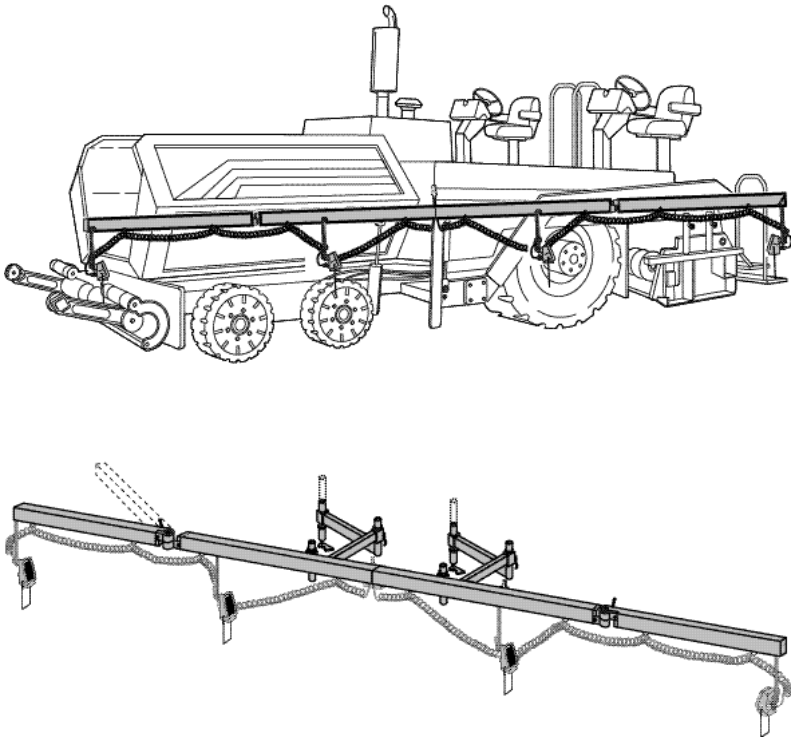

Figure 1.05

Smoothtrac® Sonic Averaging System (SAS)

The Smoothtrac is an elevation control system that combines multiple Sonic Tracker II's together to calculate an average of the physical reference. Each tracker sends its distance measurement to the Control Box which then averages all of those measurements and sends a correction signal to the tow point cylinder. The Smoothtrac replaces the mechanical ski that drags on the ground. The Smoothtrac connects to the Control Box through the tracker cable.



Laser Tracker & Trackerjack

The Laser Tracker is an elevation control sensor. It measures and controls the elevation of the screed. It works by receiving a signal from a rotating laser and sending a signal to the Control Box.

The Trackerjack attaches to the laser receiver and then mounts onto a vibration pole. Use the same cable from the Sonic Tracker II™ to power up the Laser Tracker/Trackerjack System.

The Laser Trackerjack should be removed at the end of each day and stored in its carrying case.

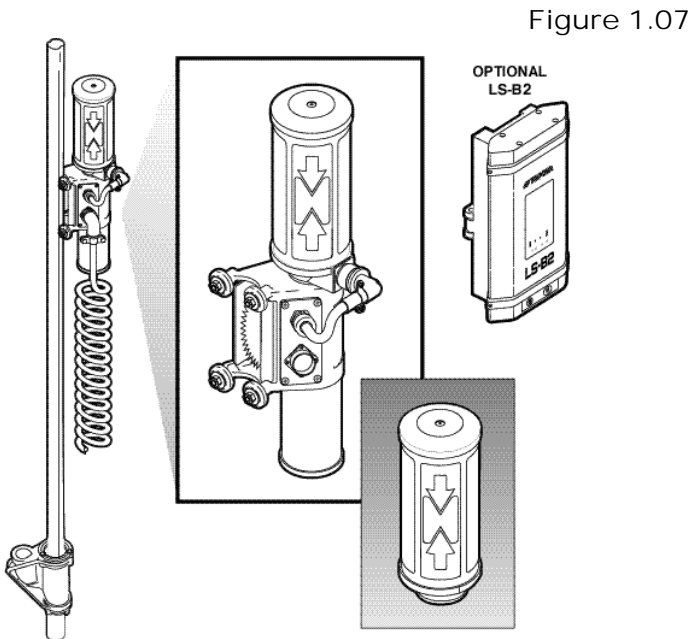

Carrying Case

A Carrying Case is provided with each System Five™. The Carrying Case is lined and includes pre-cut sections for each Sonic Tracker II™ and the Control Boxes. A cut-out section is also provided for storing coil cords.

At the end of the day, always wipe down each of the components and place them and the coil cords in the appropriate sections for storage. This will ensure the continued integrity of these components and will protect them from vandalism or theft.

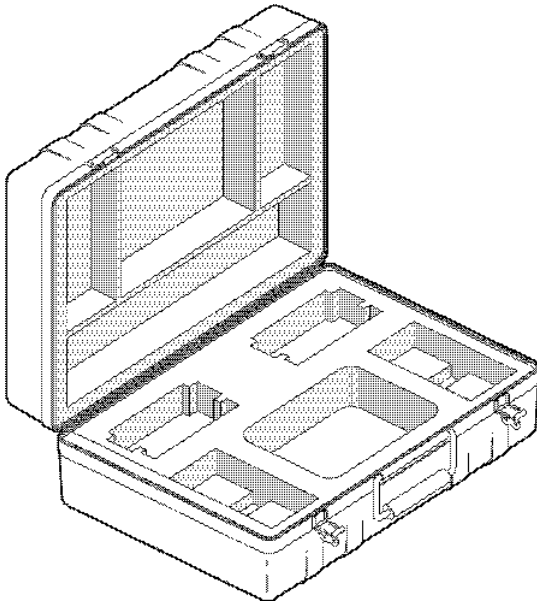

Figure 1.08



NOTICE

Keep the Carrying Case dry and store in a dry location. Never let the interior of the Carrying Case become wet. If the case does become wet, remove the components and dry it out.



Operation



NOTICE

When operating in rainy weather or in wet conditions, the Control Box, Sonic Tracker II™, and cables must be thoroughly dried BEFORE placing them in the Carrying Case at the end of the day.

Any moisture in the Carrying Case will cause condensation on the inside of the components which may severely affect accurate operation during the next paving operation.

Control Box

The Control Box is the main operator control interface for System Five™. The Control Box receives signals from the sensors and uses these signals to determine if a grade or slope correction is necessary. If a correction is necessary the Control Box sends a signal to the valve controlling the tow point cylinder on the appropriate side of the paver to raise or lower, thus maintaining correct mat thickness.

Control Box Front Panel Switches, Buttons and Controls

The operator can control and monitor the slope and thickness of the mat using the buttons and displays located on the front panel of the Control Box. The function of each is as follows:

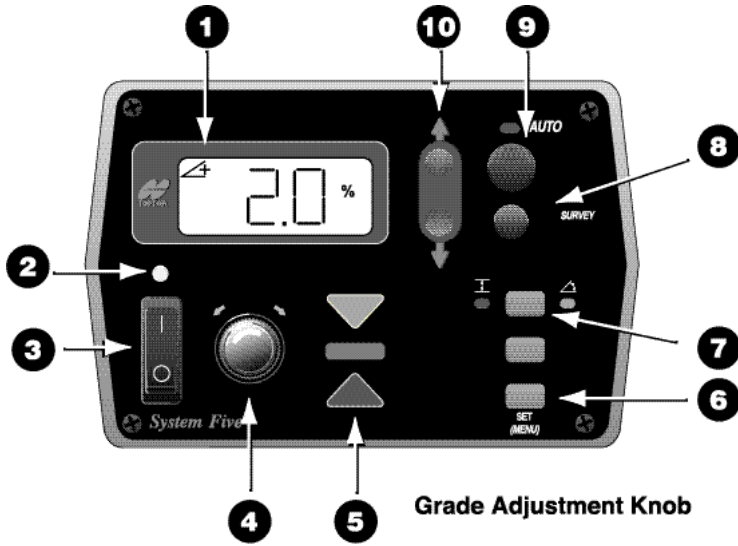

1. LCD Display
2. Light Sensor for LED Display
3. Power Switch
4. Grade Adjustment Knob
5. Grade Adjustment LED
6. Set (Menu) Button
7. Slope/Elevation Button
8. Survey Button
9. Auto/Manual Button
10. Jog Button

Figure 2.0

1 The LCD (Liquid Crystal Display)

The LCD allows the operator to view text and graphic symbols that represent elevation or slope settings that System Five™ is currently maintaining for the paver.



Figure 2.01

2 Light Sensor for LED Display

Automatically adjusts the brightness of the LED display for better visibility.

3 Power Switch

The Power Switch for System Five™.

- Press "I" on the switch to turn the Box on.
- Press "O" on the switch to turn the Box off.

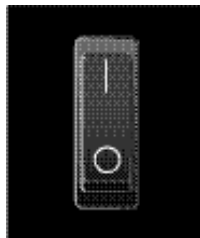

Figure 2.02

4 Grade Adjustment Knob

This knob is used to make measured adjustments to the Cross Slope or Elevation settings and allows the operator to cycle through the menu options.

- Knob adjusts the grade height for when Elevation Control is selected.

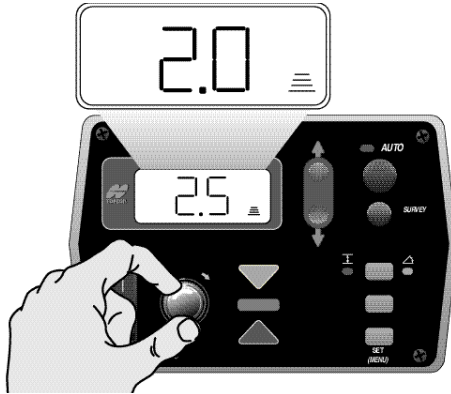

Figure 2.03a

- Knob adjusts the percentage of slope when Cross Slope Control is selected.

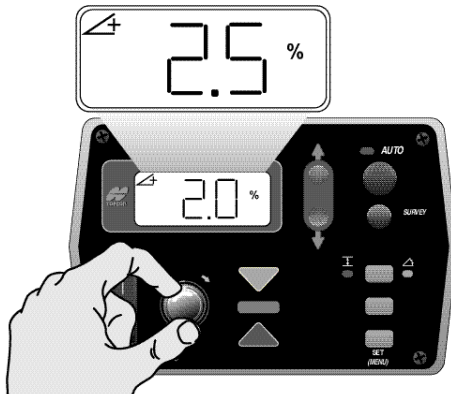
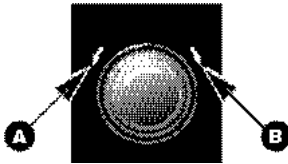

Figure 2.03b

Grade Adjustment Direction Arrows

These red arrows light up around the Grade Adjustment Knob to indicate the direction the knob should be rotated to reach On Grade.



- A** Rotate the knob counter-clockwise to reach grade.
- B** Rotate the knob clockwise to reach grade.

Figure 2.03c

5 Grade Adjustment LED

ELEVATION/SLOPE CONTROL		
LED - ACTION	ELEVATION (SONIC & LASER TRACKER)	SLOPE
	Out of range, beyond .2' above grade	Beyond 2% above grade
Solid yellow down arrow	Above grade, between .05' & .2'	Above grade, between 1% - 2%
Blinking, yellow down arrow	Above grade, between .02' & .05'	Above grade, between .5% & 1%
Blinking yellow down arrow/green bar	Within .02' of grade	Within .5% of grade
Blinking green bar	On grade	On grade
Blinking red up arrow/green bar	Within .02' of grade	Within .5% of grade
Blinking red up arrow	Below grade, between .02' & .05'	Below grade, between .5% & 1%
Solid red up arrow	Below grade, between .05' & .2'	Below grade, between 1% & 2%
Slow blinking, red up arrow	Out of range, beyond .2' below grade	Beyond 2% below grade

Figure 2.04

6 Set/Menu Button

The Set/Menu button has two functions.

- *Set Mode*
Set is used to change the reference number viewed on the display to a desired value.

Press and hold the Set/Menu button and dial in desired value using the Grade Adjustment Knob. Both the Grade Correction Indicator Lights and the Double Arrows will be lit.

Release the Set/Menu Button and the value will be saved.

NOTICE NOTICE

Using Set will not change the existing mat thickness, it only changes the reference number viewed on the display.

- *Menu Mode*
(See Accessing System Five™ Performance Settings)

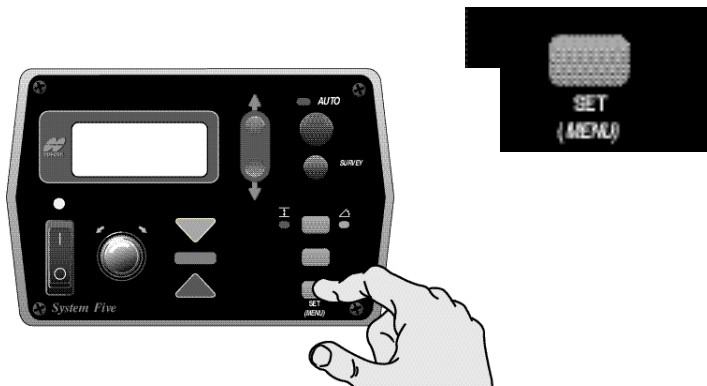

Figure 2.05

7 Slope/Elevation Button

The Slope/Elevation button is used to select System Five™ for slope or elevation control.

- *Slope Mode*

Press the button and the yellow LED next to the Cross Slope Symbol will illuminate.

- *Elevation Mode*

Press the button again and green LED next to the Elevation Symbol will illuminate.

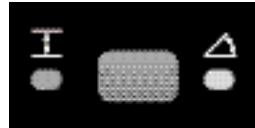

Figure 2.06

8 Survey/Indicate Button

- *Survey*
Survey is used to quickly "Null Out", or set the sensor to On-grade.

Push button for 1 second until box beeps and green On-Grade Correction Display bar is illuminated.

- *Indicate*
Indicate Mode allows the operator to continuously monitor the grade or slope setting on the LCD.

Continue pressing on the button until there is a second beep. "IND" will be shown in the LCD display. There will be no Grade lights. To exit out of Indicate Mode push either the Survey button or the Auto Button.

NOTICE NOTICE

By entering Indicate Function, System Five™ will be taken out of Automatic Mode.

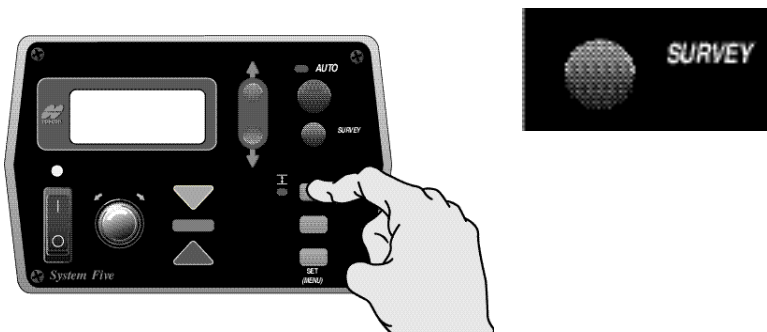

Figure 2.07

9 Auto/Manual Button

- *Automatic Mode*

The tow point cylinders are automatically adjusted up or down to maintain proper grade.

Press the red button. The red LED will light up showing that the Control Box is in Auto Mode.

- *Manual Mode*

System Five™ will display grade corrections but the tow point cylinders will not be adjusted.

Press in the Red Button. The red LED will NOT be lit, showing that the Box is in Manual Mode.

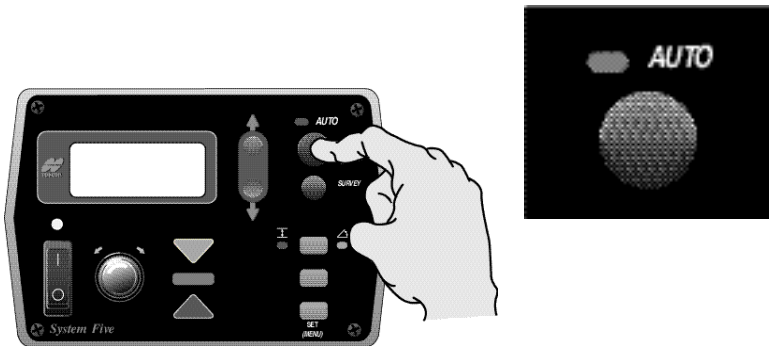

Figure 2.08

10

Jog Switch

Manually moves the tow point up or down. The Jog Switch is always active when the Control Box is turned on.

- To raise tow arm cylinder, push switch up.
- To lower tow arm cylinder, push switch down.

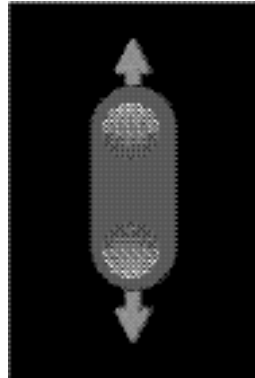

Figure 2.09

Other Control Box Components

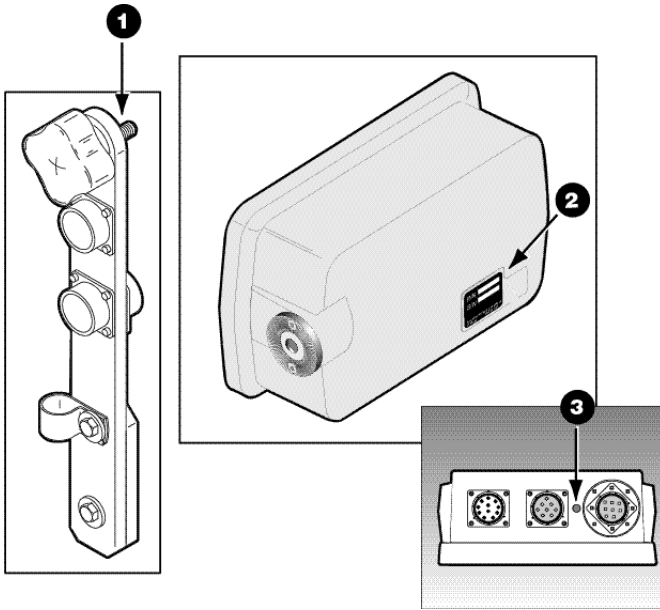

Figure 2.10

1 Mounting Knob

Secures Control Box to its mounting bracket. The bracket has a jaw that matches up with the jaw located on the side of the Box.

2 Serial Number Plate

Contains System Five™ part and serial number.

3 Audible Beeper

When the power is turned on, or calibration selections are made, the beeper will sound. The beeper may be turned Off or On for certain functions by using the Beeper Alarm Mode (see Accessing System Five™ Performance Settings section in this booklet).

Sonic Tracker II

The Sonic Tracker II™ measures and controls the elevation of the screed. A transducer, located in the bottom of the Tracker, generates sound pulses like a speaker and listens for returned echoes like a microphone. The Tracker measures the distance, and controls grade from any physical grade reference, such as a curb, stringline, or existing road surface.

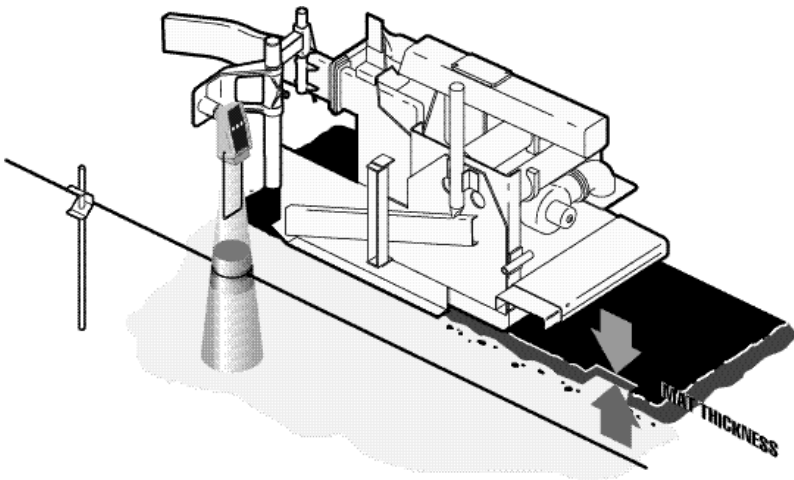

Figure 2.11a

The Sonic Tracker II™ measures the distance to a physical reference by sending out sound pulses 39 times per second. As soon as the Tracker sends out a sound wave it starts a stop watch. The sound waves go down, bounce off of any physical reference, and are reflected back to the Tracker. The Tracker measures the time it takes for the sound wave to return to the Tracker. Knowing the speed of sound, the Tracker accurately calculates the exact distance to the grade reference. The Tracker can use any physical grade reference, such as a stringline, curb, or existing surface.

STOPWATCH

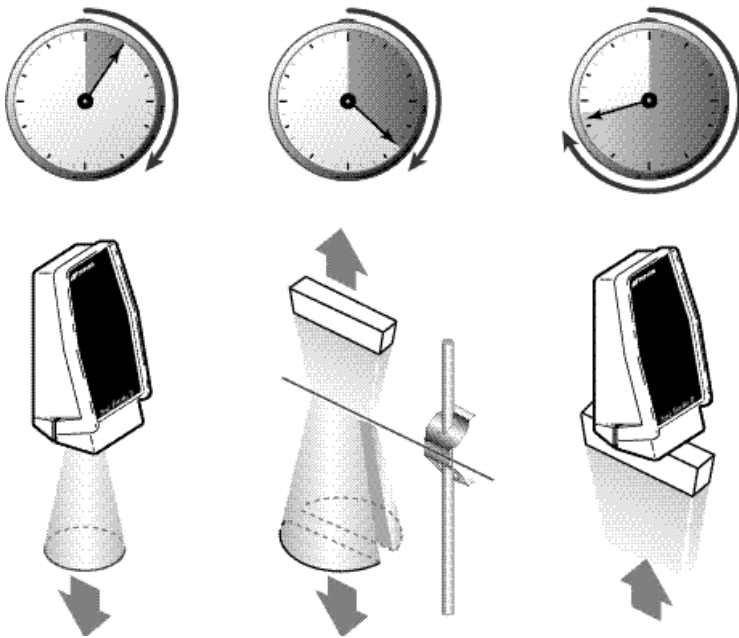

Figure 2.11b

● Working Window

Since the Sonic Tracker II™ is mounted to the tow arm or screed extension, as they raise or lower, the tracker measures exactly how far above or below the desired grade reference it is. Built into the Tracker is an operational zone, or Working Window, 2.4 inches above and below the grade reference. The grade lights on the Sonic Tracker and Control Box continuously display this grade information to the screed operator.

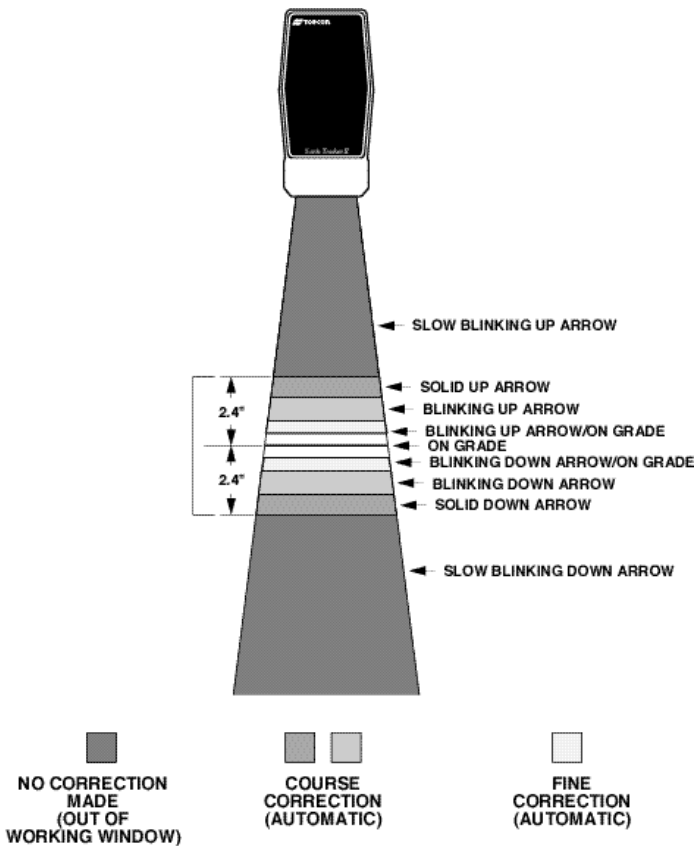

Figure 2.12a

On the paver the Sonic Tracker II will be positioned above the grade reference. Its job is to maintain the exact distance from the tracker to the reference, keeping the Tracker On Grade. If the Tracker is On Grade, the mat being laid will be at the desired depth.

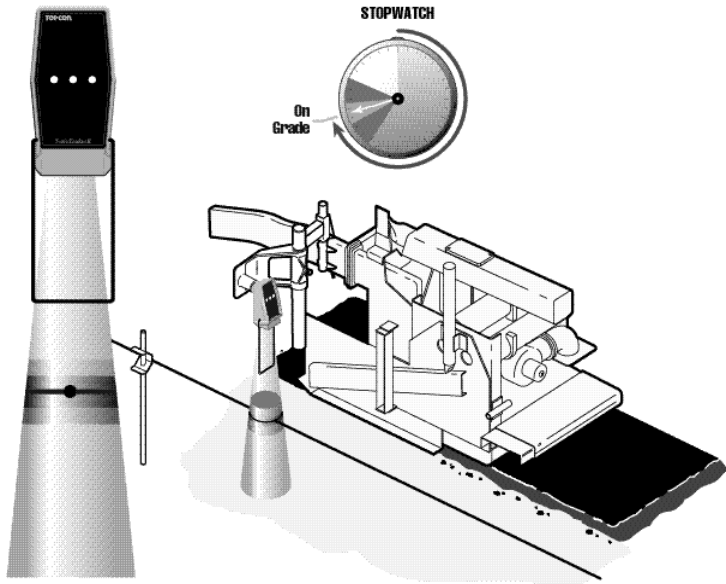

Figure 2.12b

If the screed and the Tracker II™ start to raise, the watch will be stopped at a longer time. The Tracker and Control Box will indicate a down correction arrow, and lower hydraulic valve corrections will be applied to bring the Tracker back to On Grade.

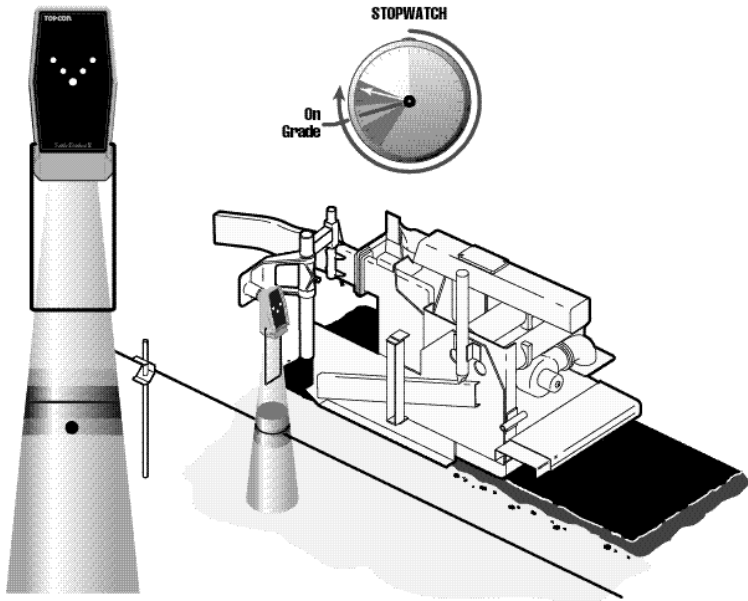

Figure 2.12c

If the screed and Tracker II™ are lowered the watch will be stopped at a shorter time. The Tracker and Control Box will indicate a raise correction arrow, and raise hydraulic valve corrections will be applied to bring the Tracker back to On Grade.

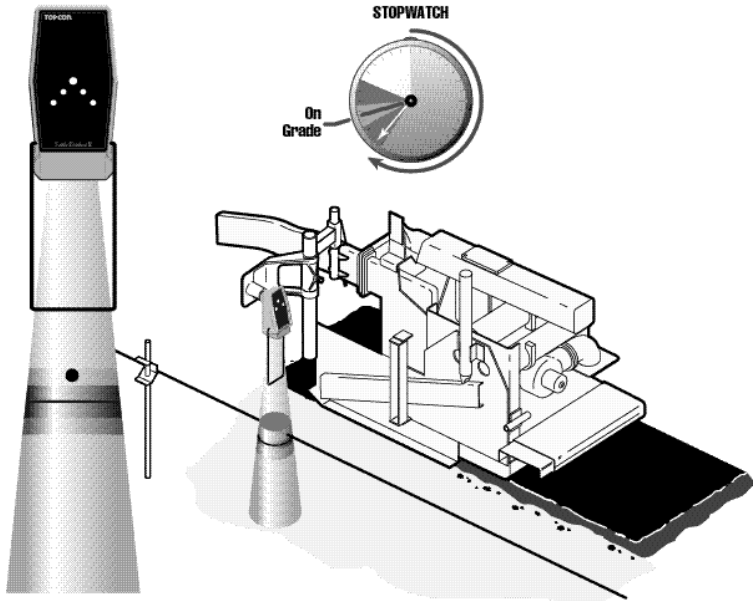

Figure 2.12d

If the Tracker II™ is side shifted off a stringline, the sound waves reflect off the ground and the Tracker's stopwatch will indicate a long time for the sound waves to return. The Tracker is out of the Working Window, and no On Grade correction signals will be applied.

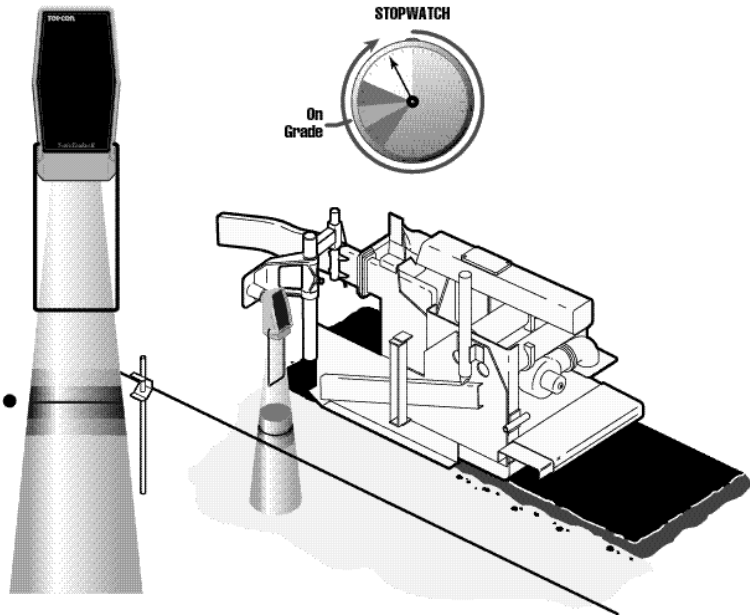

Figure 2.12e

If the Tracker sees an obstruction closer than the reference signal, such as a grade pin, the sound waves do not take as long to come back and the stop watch is stopped much sooner. The Tracker is out of the Working Window, and no On Grade correction signals will be applied.

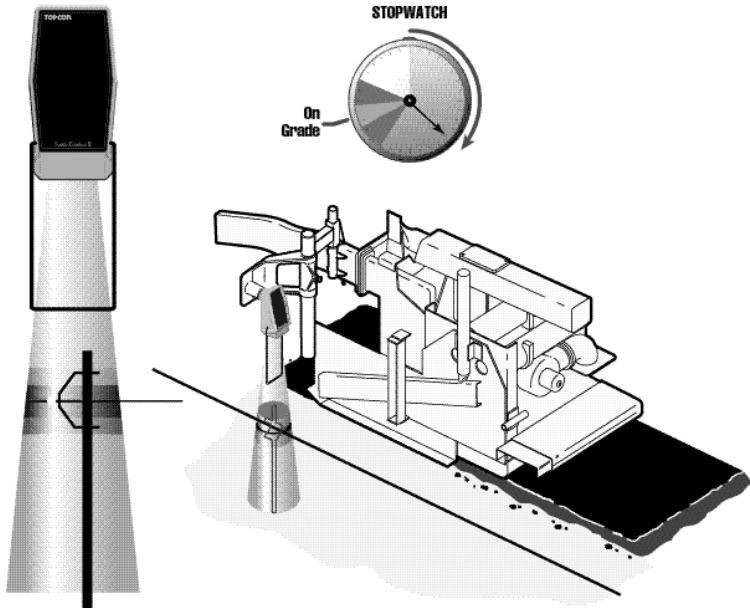

Figure 2.12f

Temperature will change the speed of sound. The tracker has a built in temperature sensor for applications with gradual temperature changes such as on graders or dozers. In paving applications you can get a more dramatic and rapid change in air temperature. To compensate for these variations a temperature bail is positioned 9 inches below the tracker. When the sound wave is emitted, the tracker records the time to the bail and continues to listen for the grade reference. If a temperature variation occurs, such as heat off a freshly paved mat, a difference in time to the temperature bail is recorded. The correction for the speed of sound is then applied to the grade reference signal, preventing a change in mat depth. The tracker corrects for temperature variations with every sound wave, 39 times per second.

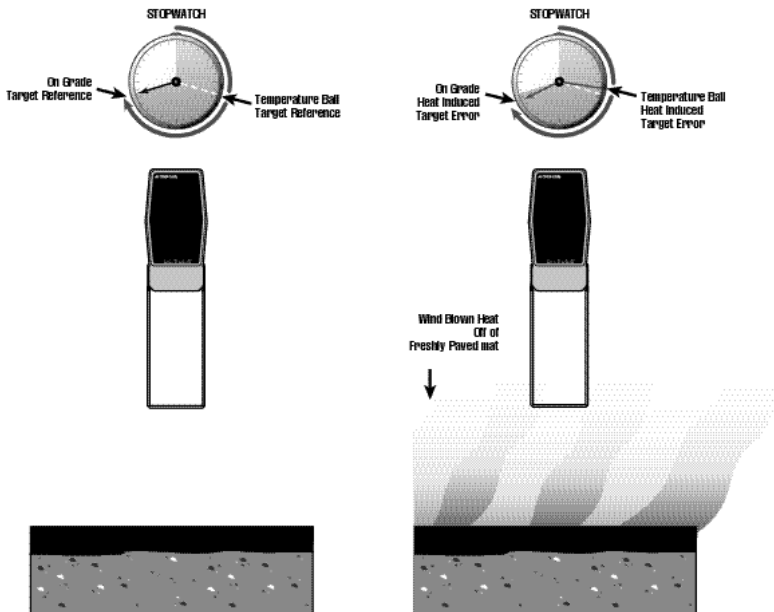

Figure 2.12g

In the upper right hand corner of the Sonic Tracker II™ faceplate is a small symbol used to represent the use of the temperature bail. The LED symbol will automatically illuminate when the bail is connected to the tracker. The tracker is casted with holes on each side for the bail to snap and lock into place.

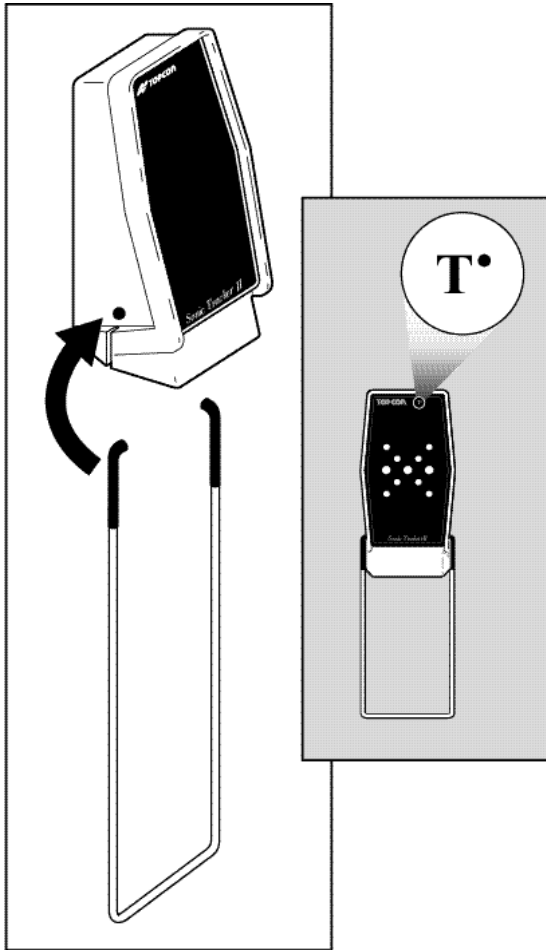

Figure 2.12h

When setting up the Tracker over a grade reference, the size of the Sonic Cone or the "footprint" needs to be considered. As an example, at about 2 feet from the tracker, you will have a footprint or cone of about 6 inches.

As the Tracker is positioned closer to the grade reference the working footprint decreases in size. As the Tracker is moving farther away from the grade reference the sonic footprint or cone will increase in size.

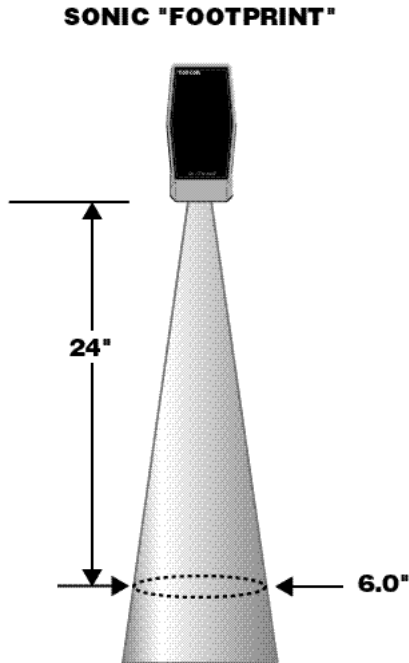

Figure 2.12i

For Laser Control a laser transmitter is used to produce a plane of light which becomes the grade control reference for the job site. The laser receiver will control the screed to lay a mat parallel to the laser beam reference.

When the laser beam is in the center of the receiver, it indicates an On-Grade signal.

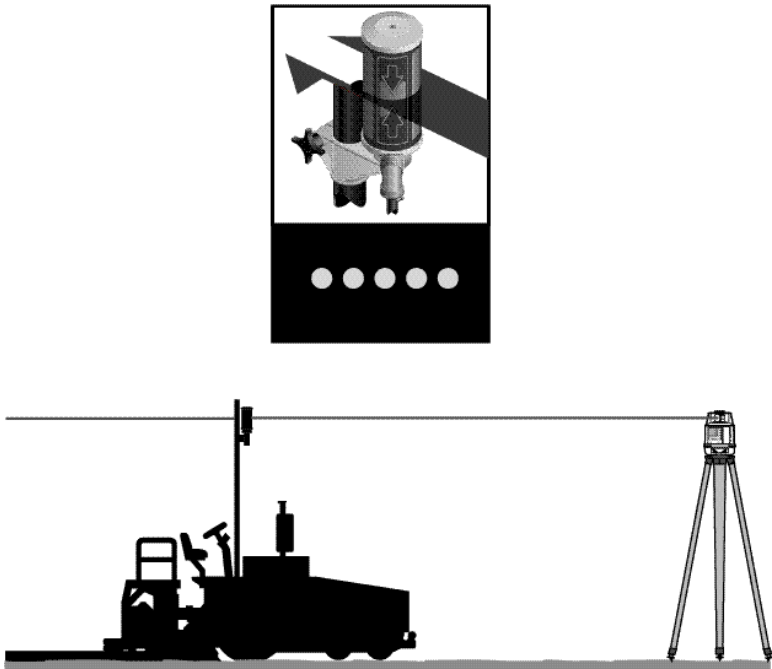

Figure 2.12j

As the screed is raised, the beam of light hits the Laser Receiver below the center and a lower signal is indicated.

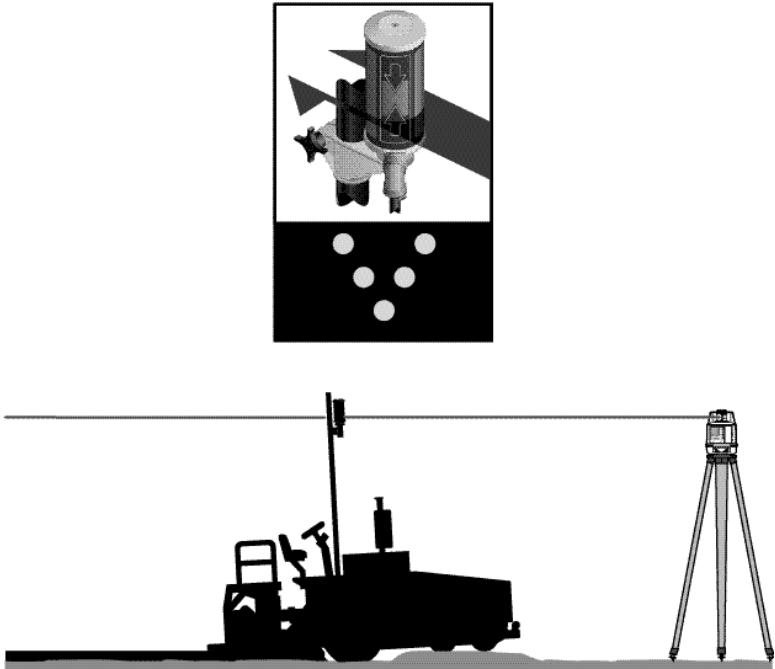

Figure 2.12k

As screed is lowered the beam of light hits the Laser Receiver above the center a raise signal is indicated.

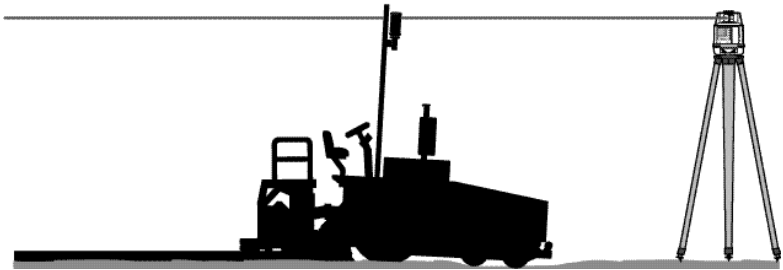
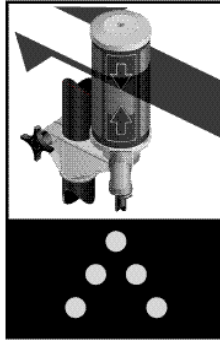

Figure 2.12I

- **Slope Control**

System Five uses a slope sensor mounted to the transducer beam on the paver to measure and control the slope of the mat being laid. The sensor contains an electronic level vial, that acts as a "precision carpenter's level". Slope control with this electric level vial is very accurate and repeatable.

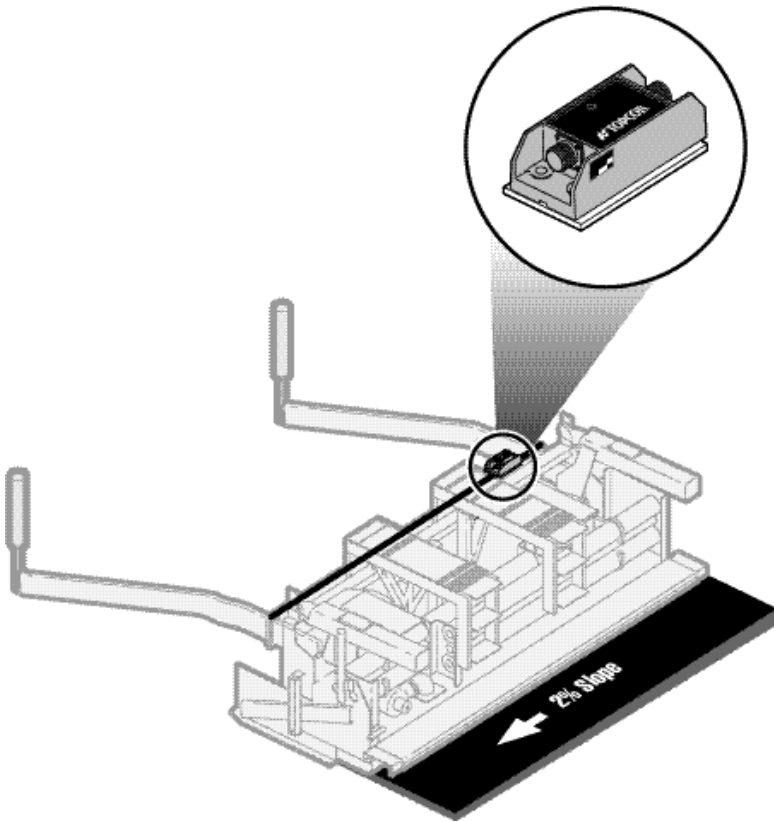

Figure 2.12m

If the required slope changes, the screed man dials the new slope in the System Five Box. The tow point cylinder on the slope side will raise or lower until the slope sensor measures the new slope.

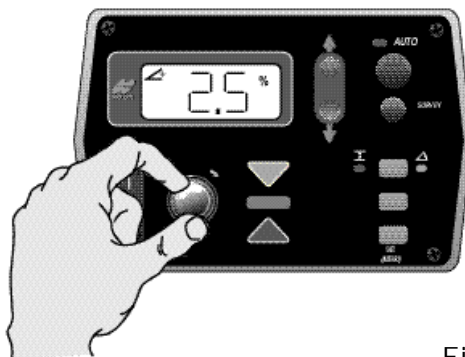
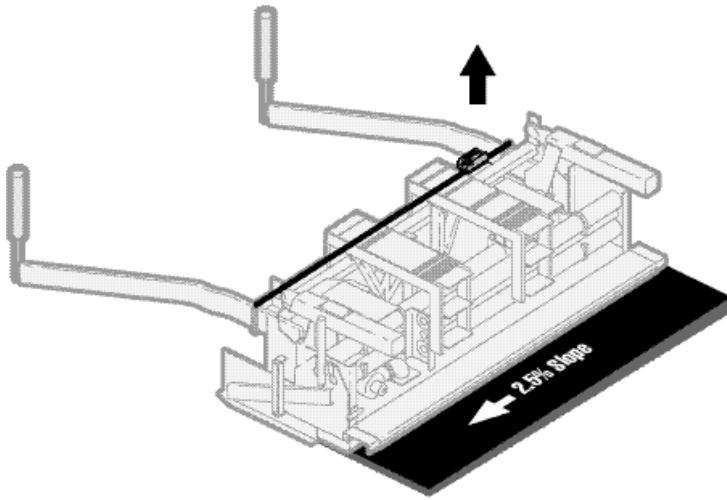

Figure 2.12n

P Performance Menu

Control Box Memory

The Control Box automatically stores all operating information when it is turned off.



If power is interrupted to the Control Box within 2 seconds after making an adjustment, the new setting will not have had time to be stored and the settings will revert to the previous (or original) settings.

Accessing System Five™ Performance Menu Settings

System Five™ Performance Menu Settings are a series of features that allow System Five™ to be modified for operator ease-of-use reasons, or performance enhancement reasons.

Performance Menu Settings Chart

	Symbol	Factory Setting	Range
Gain (Elevation)	☞☞☞	25	1-100
Gain (Slope)	☞☞☞	25	1-100
Valve Offsets	OFF	135/350	1-700
Averaging	AVG	50	1-100
Elevation Deadband	☞☞	3 mm	1-30 mm
Slope Deadband	☞☞	0.075%	.025% - .75%
Unit	☞☞	in.	in, ft, cm
Beeper Alarm	☞☞	off	on/off
Test	☞☞	no setting	open, short, pass

Figure 3.0

NOTICE NOTICE

Some of the Menu selections may not be available for the operator to select or change. Please contact dealer/distributor with any questions.

NOTICE NOTICE

The factory settings are preset values that will run most pavers. If your machine does not perform properly within those preset values, then adjust the setting accordingly until you have satisfactory machine performance.

1. Turn power off. While holding down the Set/Menu button turn the box back on. The Auto LED light and Grade Adjustment Direction Arrows will flash.



Figure 3.01a

2. Rotate the Grade Adjustment Knob to scroll through the Performance Menu selections located on the LCD.



Figure 3.01b

3. Select a menu item by pressing the Auto button.



Figure 3.01c

4. Turn the Grade Adjustment Knob to view the options available for the Menu selection.

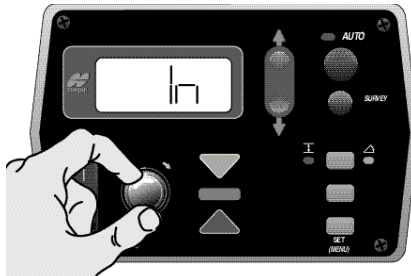

Figure 3.01d

5. Press the Auto button again to store value.

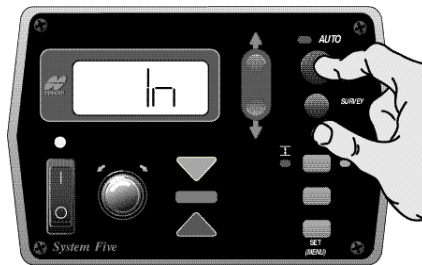

Figure 3.01e

6. To access other Menu settings just turn the Grade Adjustment Knob. To exit Performance Menu press the Set/Menu button.

Gain (Elevation)

This setting determines the speed at which System Five™ allows the Tow Point Cylinders to adjust to a change in elevation. For faster hydraulic response, increase the gain value. For slower hydraulic response, decrease the gain value. The objective is to set the gain so the screed reacts to the change in grade quickly but without "overshooting" the new elevation.

- **Gain Elevation Value Range: 1-100**
- **Factory Preset: 25**

NOTICE NOTICE

Before setting the Gain, make sure the machine's hydraulic flow controls valves are adjusted for proper cylinder speed according to the manufacturer's recommendations. Typical cylinder speed is 15-20 seconds for full up or down cylinder travel.

1. Press the Auto button to select Gain (Elevation).



Figure 3.02a

2. Turn the Grade Adjustment Knob to select the desired value - typically 25 for most paving applications.

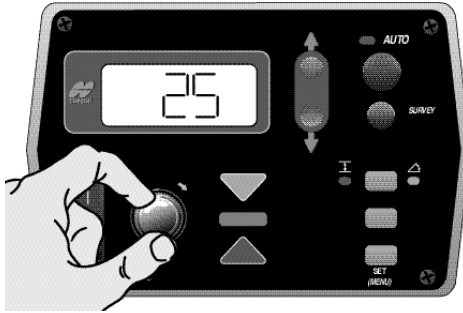

Figure 3.02b

3. Press the Auto button again to store value.
4. Rotate the Grade Adjustment Knob to access another choice in the Performance Menu or press the Menu button to exit.

Gain (Slope Control)

This setting determines the speed at which System Five™ allows the Tow Point Cylinders to adjust to a change in slope. For faster hydraulic response, increase the gain value. For slower hydraulic response, decrease the gain value. The objective is to set the gain so the screed reacts to the change in grade quickly but without "overshooting" On-Grade. Slope gain should not be set at a higher value than the elevation gain on the other side of the paver.

- **Gain Elevation Value Range: 1-100**
- **Factory Preset: 25**

NOTICE NOTICE

Before setting the Gain, make sure the machine's hydraulic flow controls valves are adjusted for proper cylinder speed according to the manufacturer's recommendations. Typical cylinder speed is 15-20 seconds for full up or down cylinder travel.

1. Press the Auto button to select Gain (Slope Control).



Figure 3.03a

2. Turn the Grade Adjustment Knob to select the desired value - typically 20% to 25%.



Figure 3.03b

3. Press the Auto button again to store the value.
4. Rotate the Grade Adjustment Knob to access another choice in the Performance Menu or press the Menu button to exit.

NOTICE NOTICE

Do not set slope gain at a higher value than the elevation gain on the other side of the paver. A higher value may cause the slope to be over reactive.

Valve Offset

The valve offset is the minimum amount of electrical signals sent to the valve which causes the hydraulic cylinder to move. If the valve offset is too small, the sensor will not reach On-Grade. Likewise, if the valve offset value is too large, the sensor will move too much and overshoot On-Grade. Valve offsets should be set before adjusting elevation and slope gains and averaging.

- **Valve Offset Value Range: 1-700**
 - Solenoid: 135**
 - Proportional: 350**
- **Factory Preset: 135**

NOTICE

Valve offsets should be the first performance menu function completed. The paver should be run until the hydraulic oil is at normal operating temperature before the value offset functions performed. Once they are set, valve offsets should not need to be adjusted unless the Control Box has been moved to a new paver, or the hydraulic performance has changed.

1. Press the Auto button to select Valve Offset. This will automatically activate the value screen for Raise Offsets. The Raise Grade Correction Display Arrow will illuminate, and the Control Box will begin sending a raise correction signal to the valve.

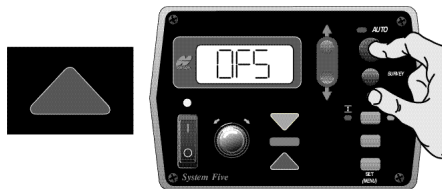

Figure 3.04a

2. Turn the Grade Adjustment Knob counterclockwise, decreasing the Valve Offset value until the hydraulic cylinder is not moving.

Then slowly rotate the Grade Adjustment Knob clockwise until the hydraulic cylinder just begins to move up.



Figure 3.04b

3. Press the Auto button to store the Raise Offset Value. Pressing the Auto button also switches the box to Lower Offset. The Lower Grade Correction Display Arrow will illuminate and the Control Box will begin sending a lower correction signal to the value.



Figure 3.04c

4. Turn the Grade Adjustment Knob counter-clockwise, decreasing the Valve Offset value until the hydraulic cylinder is not moving.

Then slowly rotate the Grade Adjustment Knob clockwise until the hydraulic cylinder just begins to move down.

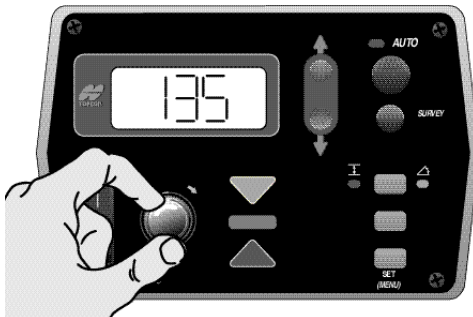

Figure 3.04d

5. Press the Auto button to store the Lower Offset Value. Pressing the Auto button will also return you to the Performance Menus.
6. Rotate the Grade Adjustment Knob to access another choice in the Performance Menu or press the Set/Menu button to exit.

Averaging

This setting changes the amount of dampening, or filtering, applied to sonic tracker and laser receiver measurements. It can be thought of as the time period over which a running average of the elevation measurement is calculated. A lower value will average fewer elevation measurements, allowing the system to react more quickly to smaller grade changes. This will make it more susceptible to fluctuations in temperature or small obstructions.

A larger value will average more elevation measurements, preventing the system from reacting to undesirable items close to the reference. This will also make it less susceptible to fluctuations in temperature or small obstructions.

- **Averaging Value Range: 1-100**
- **Factory Preset: 50**

1. Press the Auto button to select Averaging.



Figure 3.05a

2. Turn the Grade Adjustment Knob to select the desired value.



Figure 3.05b

3. Press the Auto button again to store the value.
4. Rotate the Grade Adjustment Knob to access another choice in the Performance Menu or press the Menu button to exit.

Deadband Elevation

Deadband is the area of the Working Window that is On-Grade. While the reference is within that area, the paver's valves are idle (closed). Therefore the wider the Deadband (On-Grade area), the more a reference can move up or down without a correction being initiated. Once the signal from the reference is out of the deadband, System Five™ will drive the hydraulics to place the reference back in the CENTER of the deadband.

- **Deadband Elevation Value Range : 1-30 mm**
- **Factory Preset : 3mm (.01', or 1/8'')**

1. Press Auto Button to select Elevation Deadband.

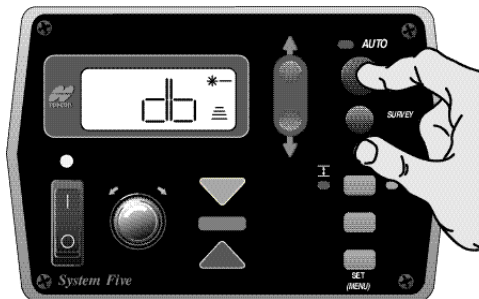

Figure 3.06a

2. Turn the Grade Adjustment Knob to select the desired value - typically 3mm (0.01').

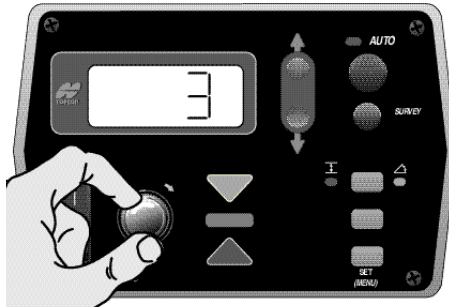

Figure 3.06b

3. Press the Auto button again to store the value.
4. Rotate the Grade Adjustment Knob to access another choice in the Performance Menu or press the Set/Menu button to exit.



NOTICE

The amount of Deadband should be carefully selected. Too small of a Deadband will cause the tow point cylinder to constantly hunt up and down while the sensor tries to find On-Grade. Too large of a deadband will not allow the sensor to send grade corrections to the valves, causing unwanted variations in the mat thickness.

Deadband Slope

Deadband is the area of the Working Window that is On-Grade. While the reference is within that area, the paver's valves are idle (closed). Therefore the wider the Deadband (On-Grade area), the more a reference can move up or down without a correction being initiated. Once the signal from the reference is out of the deadband, System Five™ will drive the hydraulics to place the reference back in the CENTER of the deadband.

When the Deadband is changed it adds or takes away from the fine correction region (1% above or below On-Grade) of the slope sensor. It does not add this distance to the overall working range.

- **Deadband Slope Value Range : 025 - 750%**
- **Factory Preset : 075**

1. Press the Auto button to select Slope Deadband.

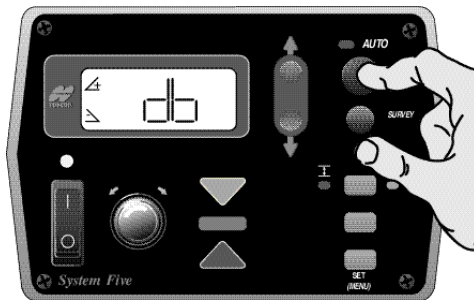

Figure 3.07a

2. Turn the Grade Adjustment Knob to select the desired value typically 075.



Figure 3.07b

3. Press the Auto button again to store the value.
4. Rotate the Grade Adjustment Knob to access another choice in the Performance Menu or press the Set/Menu button to exit.



NOTICE

The amount of Deadband should be carefully selected. Too small of a Deadband will cause the tow point cylinder to constantly hunt up and down while the sensor tries to find On-Grade. Too large of a deadband will not allow the sensor to send grade corrections to the values, causing unwanted variations in the mat thickness.

Beeper Alarm

When System Five™ is in Automatic Mode and the Sonic Tracker gets a reference signal that is out of the Working Window (more than 2.0" from grade) a single audible beep will be heard.

1. Press the Auto button to select Beeper.



Figure 3.08a

2. Turn the Grade Adjustment Knob to turn the beeper ON or OFF.



Figure 3.08b

3. Press the Auto button again to store the choice.
4. Rotate the Grade Adjustment Knob to access another choice in the Performance Menu or press the Set/Menu button to exit.

Unit

Set display to read in feet, inches, or centimeters.

1. Press Auto Button to select Units.



Figure 3.09a

2. Rotate the Grade Adjustment Knob to select a measuring unit (either feet, inches or centimeters).

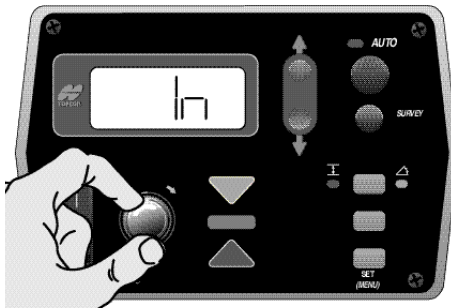

Figure 3.09b

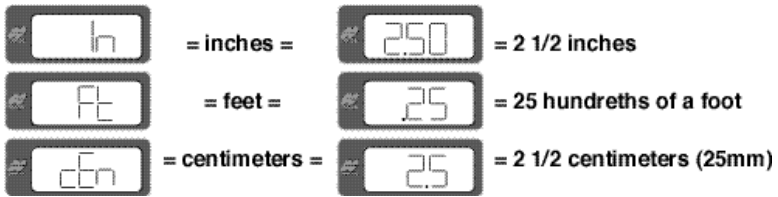

Figure 3.09c

3. Press the Auto button again to store the value.
4. Rotate the Grade Adjustment Knob to access another choice in the Performance Menu or press the Set/Menu button to exit.



NOTICE

If the Unit is changed, the working window of the Sonic Tracker will have to be reset to grade.

Test

This tests the valves for shorts and disconnected valves. It test the Raise Valve first and then the Lower Valve.

1. Press the Auto button to select Test Mode.

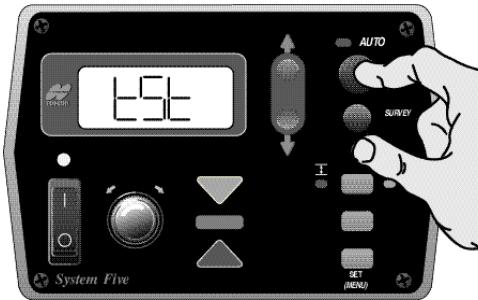

Figure 3.10a

2. Display will read "Pass" if the raise valves test out OK. If there is a problem the display will read "Open" or "Short".
3. Press the Auto Button to test lower valves. The display will read "Pass" if the lower valves test out OK. If there is a problem the display will read "Open" or "Short".



- Good Valve



- Valve NOT connected



- Valve wires are electronically shorted

Figure 3.10b

4. Press the Auto button once more to return to the Menu selections.
5. Rotate the Grade Adjustment knob to access another choice in the performance menu or press the Set/Menu button to exit.

P Principles of Paving

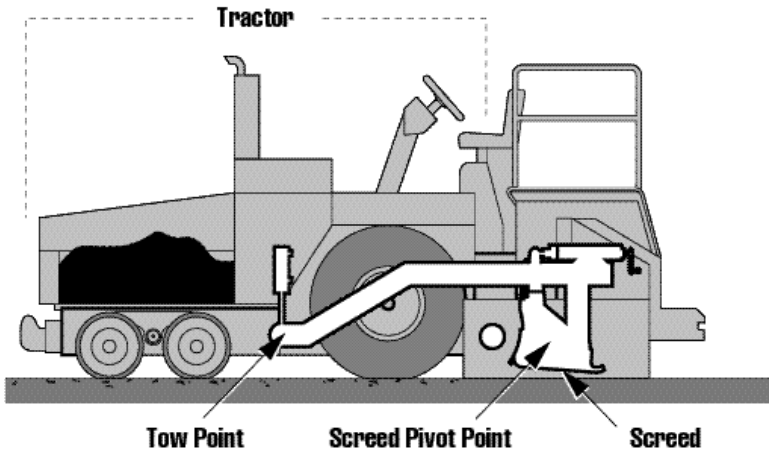

Figure 4.0

Paver Components

Modern pavers consist of two major units: **The Tractor and the Screed.**

The primary function of the tractor is to propel the truck or paver feeding device, to convey and distribute the paving material and to tow the screed. The function of the screed is to strike off the material in preparation for further compaction. The screed is mounted to the tow arms at the screed pivot points and is attached to the paver at the tow points.

How a Screed Works

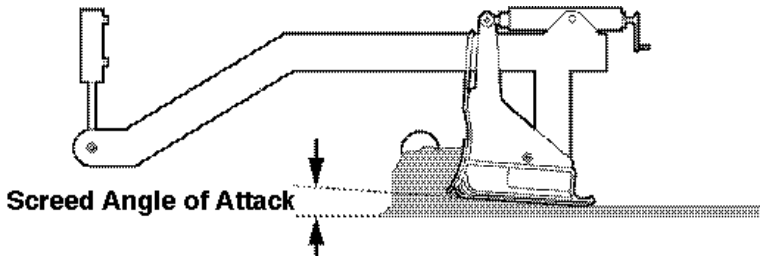

Figure 4.01a

The screed on all modern pavers is of the "floating, self leveling" type. As the paver tows the screed unit forward, paving material flows under the screed. This causes the screed to float on the mat of material, thus establishing mat thickness. Since the screed is mounted to the paver only at the tow points, the screed is completely free to float up or down. The screed will always seek its own "Planing Angle", or angle of attack, dependent on the combination of forces acting upon the screed.

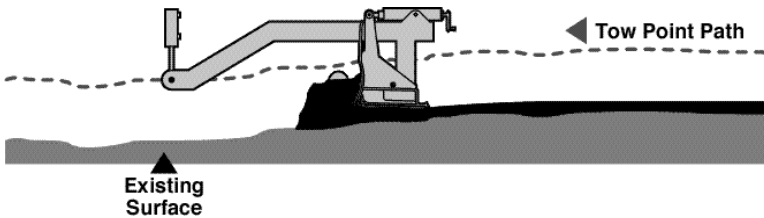

Figure 4.01b

- If the screed angle of attack is increased the screed rises increasing the mat thickness.
- If the angle of attack is decreased, the screed will settle providing a thinner mat surface.

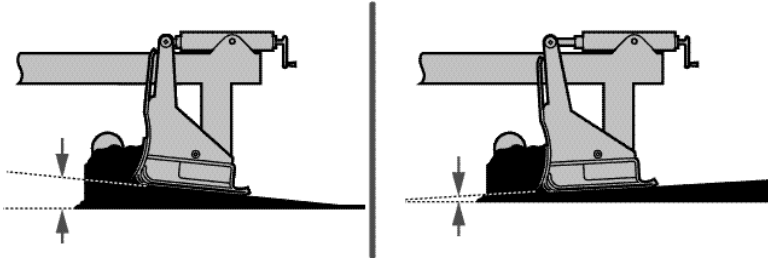

Figure 4.01c

Because the screed floats, it will not immediately react to a change in the tow point. It needs a certain amount of time or distance to make a correction in the mat thickness. If the tow point is changed by a unit of one, the paver must move one tow arm length before the screed will correct 63% of the elevation. After 2 tow arm lengths 83% of the correction is made and 3 tow arm lengths would account for 95%. It takes 6 tow arm lengths to achieve 100% of the elevation change. Considering that 95% of the change takes place after 3 tow arm lengths, this can be used in practical applications to qualify for full correc-

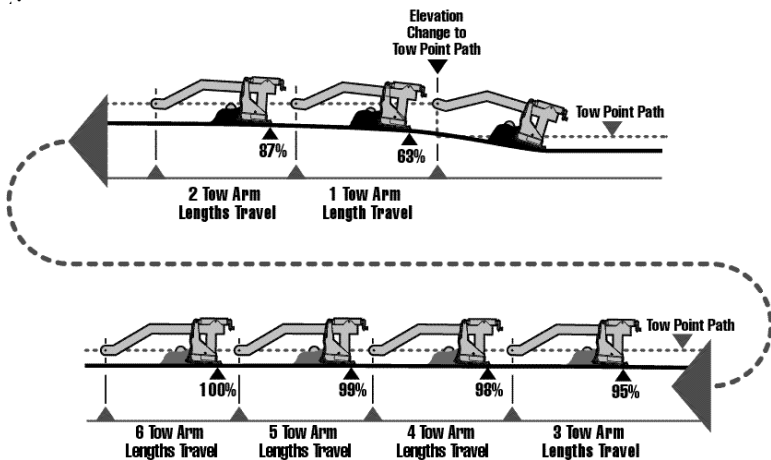

Figure 4.01d

The same is true when making elevation changes with the manual thickness cranks.

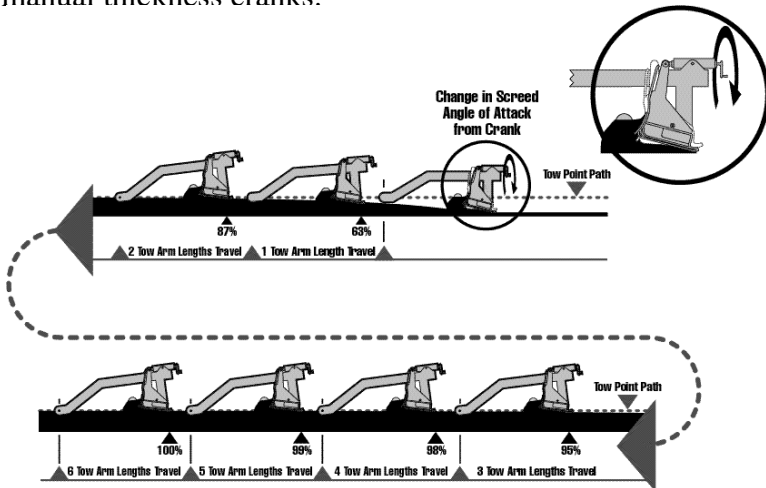

Figure 4.01e

It is very important to check mat depth in several locations before making any elevation corrections. The surface being paved may have wheel ruts, dips and ridges that will give an untrue indication of overall mat depth. Check several spots to get an average. If an elevation change is made, wait 3 tow arm lengths for full correction. Too much cranking and stabbing will cause raise and lower changes that will produce an uneven mat surface.

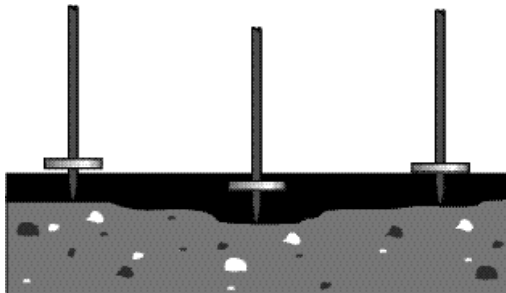

Figure 4.01f

There are four main forces acting on the screed at all times. These forces occur whether you are paving in manual or with automatics. A change in any one of the forces will cause the screed to rise or fall, changing the mat depth. The key to smoother paving is to keep these forces as **constant as possible**. Let's review each of the forces and what factors will have an effect.

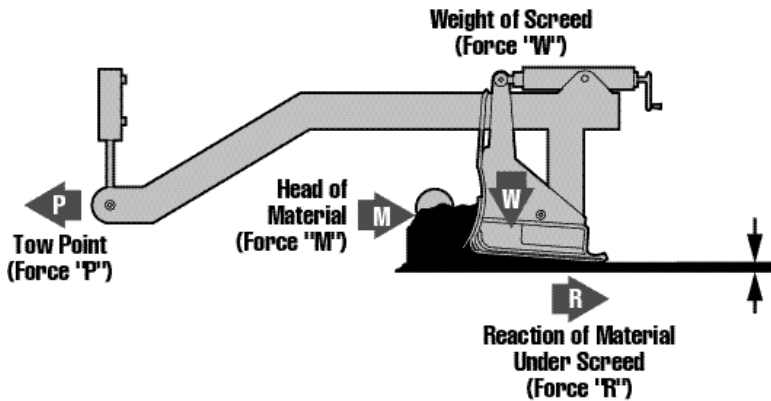

Figure 4.01g

Tow Point Force

The tow point force (P) is the resistance to forward travel. The P force will remain constant if the paver is kept moving at a consistent speed at all times. If the paver is allowed to stop, the screed will settle in the fresh mat and leave a mark. The mark cannot be fully smoothed out by the roller and a bump will end up in the mat. This will show up in the profilograph readings and reduce your chance for any bonuses. Changing the speed of the paver will also cause the screed to rise and fall, affecting the mat thickness. The optimum paving speed is determined by the depth and width being paved and the rate at which material can be delivered to the job. Calculate the tons/hour into feet per minute. Do not start and stop the paver.

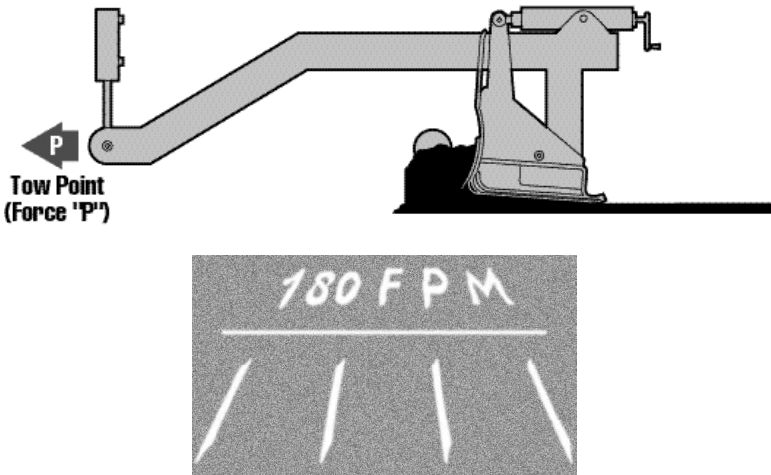

Figure 4.02

Truck Exchange is another tow point force. It is very important that truck exchanges be carried out as smoothly as possible to avoid disturbing the smooth, uninterrupted forward motion of the paver. The following lists some steps to take to avoid disturbance of the paving operation by trucks.

1. Stop the mix delivery truck close, but not too short of the paver. Always allow the paver to pickup trucks on the run.
2. Never allow the truck to bump the paver. Allowing trucks to bump the paver when backing up, can drive the screed into the mat and produces bumps and ridges which may not roll out.
3. Trucks applying and holding their brakes excessively while dumping their load may cause the paver to slow, which in turn will cause the screed to rise. The truck driver should apply only light pressure on the brakes, sufficient to maintain contact with the paver.
4. Dumping of material in front of the paver as the truck pulls away after emptying its load into the hopper, can cause the paver to ride over the pile of material with subsequent adverse effects on mat quality. Avoid trucks pulling away prior to completely dumping all material. Use a dump person to monitor and regulate truck movements in front of the paver.

"M" Head of Material

As described before, one of the primary functions of the paver tractor is to convey and distribute paving material onto the ground in front of the entire width of the screed. This material, once deposited in front of the screed is the head of material over which the screed will pass.

One of the keys to smooth paving is to maintain this head of material as constant as is possible. The resistance to forward motion exerted by the head of material (M) is one of the major component of resistance to forward motion. Control of this force is a basic and necessary function of any paving operation.

The volume and consistency of the head of material determines how much paving material flows under the screed and influences mat thickness and surface texture.

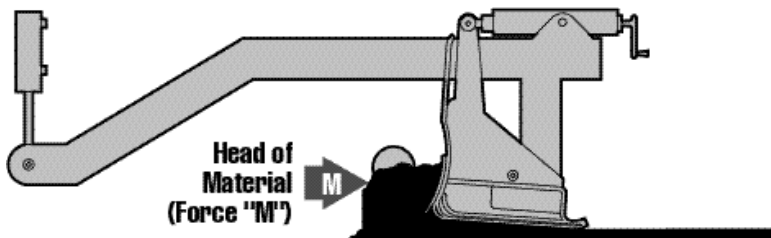

Figure 4.03a

The most common factor affecting force "M", the head of material, is the following:

Incorrectly Adjusted Automatic Feeder Controls:

These systems, whether they are of the "hanging paddle" type or the sonic sensors should be adjusted to operate the auger/conveyor assemblies 95 to 100% of the time.

On/off operation of the auger system will cause fluctuation in the head of material.

The highest quality mat will generally result when a constant head of material is maintained across the entire width of the screed and the material almost covers the auger shaft. If the volume of paving material is too high, there is resistance to the travel of the screed. This causes the screed to rise and can result in ripples, auger shadows and long waves. It also results in increased auger wear.

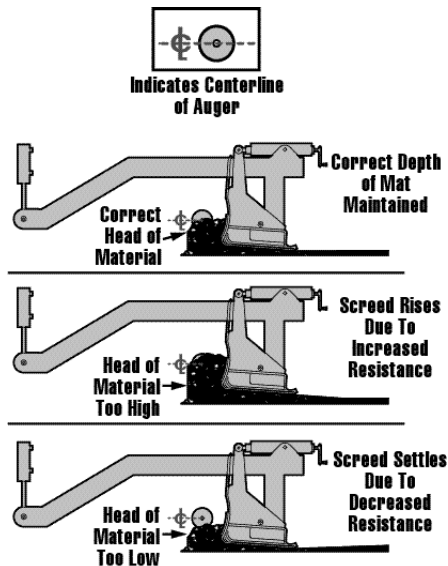

Figure 4.03b

"R" Reaction of Material Under Screed

Ideally, every truck load of material delivered to the paver would be exactly like every other load with no variation. However, as a practical matter, changes in mix characteristics such as mix temperature, density, gradation, A.C. Content, segregation, etc., will affect the internal stresses developed within the mix, which in turn affects the resistance of the mix to flow under the screed. The key element to bear in mind is that the screed passing over the paving material will compact the material to a certain degree. Variable in the resistance of the material to compactive forces will cause changes in the screed's angle of attack, which in turn will affect mat thickness and therefore mat smoothness.

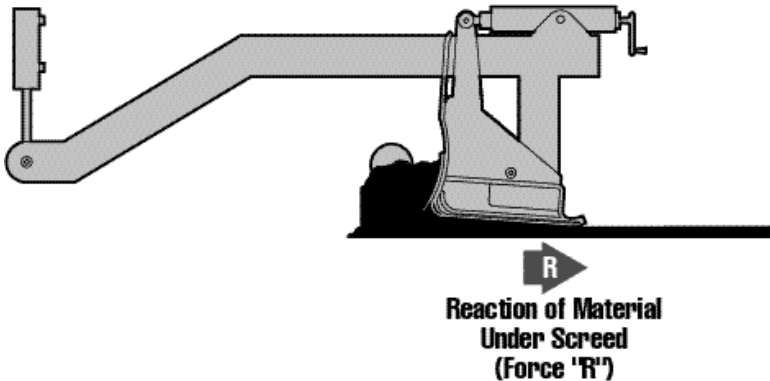

Figure 4.04

Mix Characteristics

Gradation

This aspect of the paving material will vary according to the intended use of the material as a base course, binder course or the final wearing surface. Normally, maximum aggregate size, ratio of aggregates, fines content and most importantly, asphaltic binder content, is specified by the contracting agency.

Adherence to mix design specifications is usually the responsibility of the material supplier.

Segregation is a material deficiency caused by a separation of the larger aggregate sizes from the bulk of the paving material.

This condition is encountered especially in mixes with relatively large maximum size aggregate (example: 1" and larger, the so called "large-particle" mixes). When paving material is deposited in piles, as in an asphalt plant silo, a haul truck, a paver hopper, on the ground in front of the paver in a windrow, or on the ground in the auger chamber, segregation can and does frequently occur.



NOTICE

The areas listed above where segregation can occur are all areas that the material may encounter before being laid down as a mat. Therefore, these areas of segregation must be addressed prior to any paving. The screed cannot rectify segregation during the paving process.

Segregation can also be the result of improper hopper dumping:

Duration normal operation, the vibration of the pavers hopper will cause segregation. Therefore, dumping the hopper after each truck should be avoided because material that has rolled to the outside of the hopper (the large aggregate) will fill the conveyors and auger chamber and result in a segregated area behind the paver with a noticeable difference in surface texture.

If It Doesn't Look Right, It Isn't Right:

Surface and texture irregularities indicate that the homogeneous characteristics of the material in the mat have been interrupted, which usually results in bumpiness and premature failure of the pavement in those areas.

Segregation can also be the result of excessively worn augers: "Center Streak" segregation can be caused by worn "Kicker Paddles" at the center chain cause or near the outside auger bearings. In fact center streak segregation is frequently caused by incorrect arrangement of the auger segments adjacent to the auger chain case. (Consult the Manufacturers Manual).

"Center Streak" segregation is also caused by feeder gates being set to tow. Adjust as necessary to provide sufficient uniform material at the center of the paver.



NOTICE

"Center Streak" segregation can be limited and even eliminated by slowing paving speed.

Mix Temperature

A common paving problem is inconsistent temperatures in the asphalt mix. As the material cools it loses its viscosity making it more difficult to compact. If the resistance to compaction increases, the screed will naturally increase its angle of attack and begin to float up. This will change the mat depth, resulting in bumps in the surface. If the mix and or screed temperature are too low, the screed may no longer slide smoothly over the material and a tearing of the mat will occur.

Some simple steps to take to control **temperature variations**:

- A. Ensure that haul trucks take the shortest, most practical route to the paver. Make certain that all trucks take the same route to the paver.
- B. Make sure that the trucks arrive at the same order in which they were loaded at the asphalt plant.
- C. Ensure that no bunching of trucks occurs at the paver, with several trucks waiting to dump their loads.
- D. Match lay-down rate to material delivery rate.



NOTICE

Temperature problems may occur will before the time the material is loaded into the trucks, or during the trip to the paver. They can be the result of temperature variations at the plant. If this is not addressed prior to delivery of material to the paver, waviness in the he mat will be the result.

"W" Weight of Screenshot

For weight of screed force "W" to remain constant, the weight of the screed or the downward pressure exerted by the screed on the paving material should not change. The weight of the screed is measured in pounds per square inch.

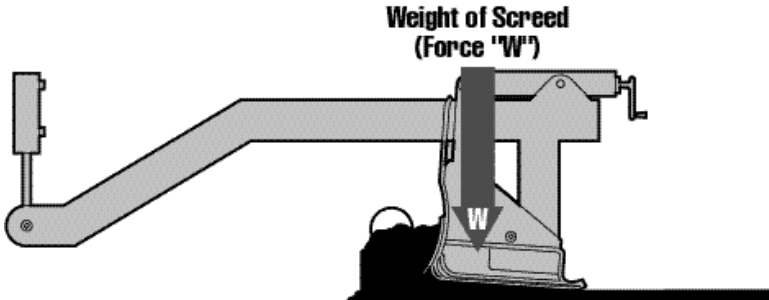

Figure 4.05a

Members of the paving crew climbing on and off the screed will have some affect on the weight of screed force.

The primary factor affecting this force is changing the width of the screed. Extendible screeds weigh the same whether they are fully retracted or fully extended. The difference is the wider the extension of the screed the greater the surface area of paving material to support. An extended screed has fewer psi, which means less compaction, causing the screed to raise.

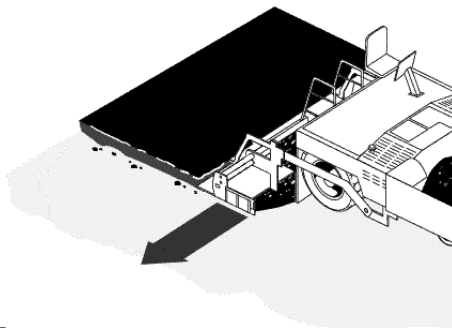

Figure 4.05..

Quality of Base Being Paved

There are factors other than the four main forces that can have an effect on the quality of the mat. An important one is the quality of the base to be paved. It makes more sense to build smoothness from the base up, than to try to smooth a road in the last lift of paving. However, on overlay paving jobs we have to work with what we have.

Remember that a mat which appears smooth immediately behind the paver, may actually contain areas of considerably varying thickness of material as a result of undulations in the base being paved. Due to the principle of "Differential Compaction" high spots will not compact as much as the low, therefore allowing some of the irregularities to be rolled back onto the mat. To minimize this problem, lay a leveling course in the low spots or pave multiple lifts to average out the irregularities.

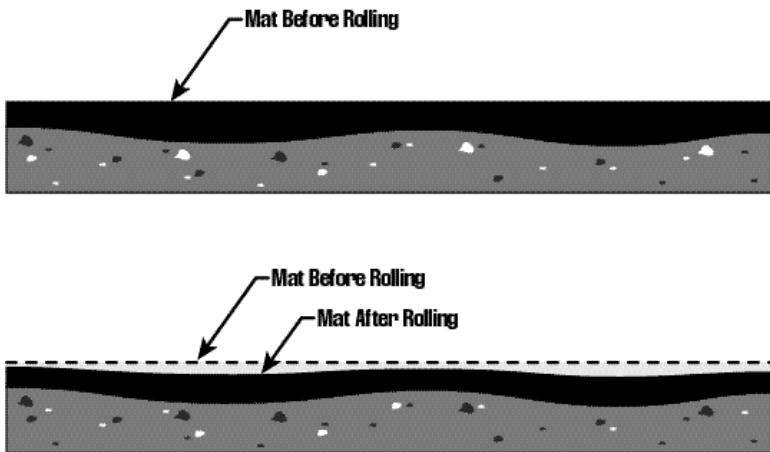

Figure 4.06

Rolling Techniques

A well laid mat can end up with a poor ride quality if proper rolling methods are not followed. Consult your compaction equipment manufacture's manuals and handbooks on compaction techniques.

Controlling Mat Quality

The primary purpose of the asphalt paver is to place a smooth mat of material. The primary function of System Five is to control the vertical position of the screed in relation to the surface being paved. Automatic grade and slope control systems can help tremendously in controlling mat smoothness but mat quality is also dependent on the following factors:

- A. Non-Stop, Continuous Operation of Paver
- B. Constant Speed of Paver
- C. Truck Exchange
- D. Head of Material
- E. Mix Characteristics
 - 1. Gradation
 - 2. Segregation
 - 3. Mix Temperature
- F. Screed Compaction
- G. Quality of Base Being Paved
- H. Rolling Techniques



NOTICE

Changes in any of these factors will cause a change in mat thickness, density, surface appearance and mat quality. If changes must be made, make them as gradually as possible. Abrupt changes in any of the above factors will produce rapid changes in mat thickness, adversely affecting mat quality.

G etting Ready to Pave

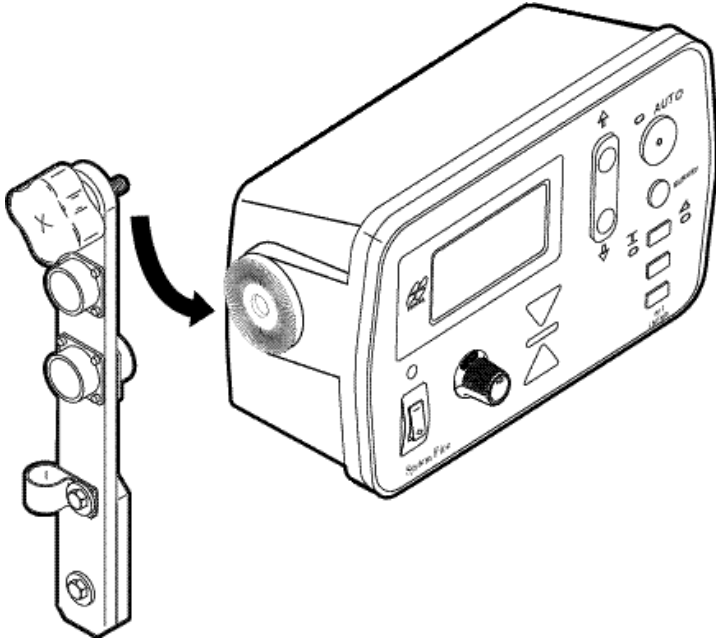

Figure 5.0

This chapter is designed to get the paving crew started using System Five™. The job application and the desired results will determine what type of non-contacting controls should be used; i.e. sonic, slope, laser and SAS. The components should be mounted on the paver and then the paver itself must be properly set up.

Connect the cables into the Control Box:

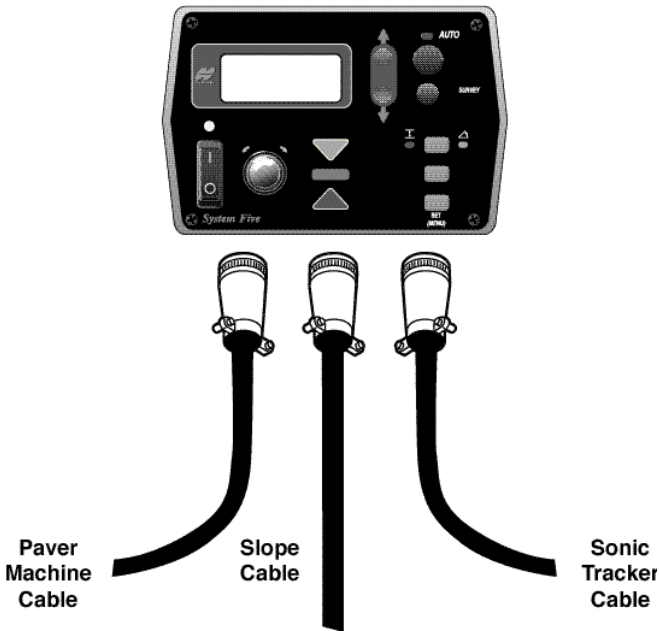

Figure 5.01



NOTICE

Due to different types of machine configuration, your cable connections may vary.

Machine Setup

To start paving with System Five™, set up the paver just as you would under manual control. Place the screed on blocks or lath set for the desired paving thickness. Make sure you account for material compaction.

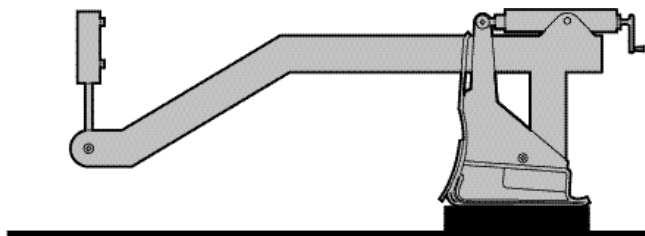

Figure 5.02a

Center the tow point cylinders to maximize travel in raise or lower directions. You can use the jog switch on the System Five™ Box (Power must be on) or the switch provided with the paver.

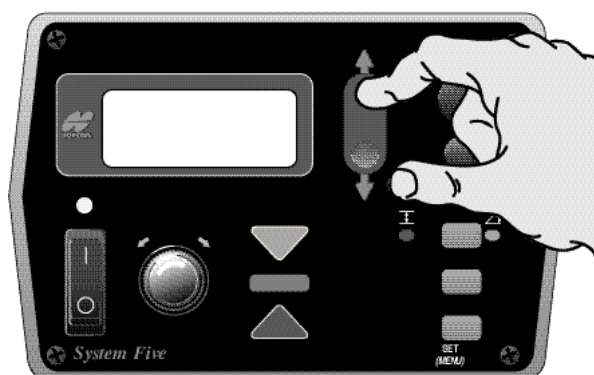
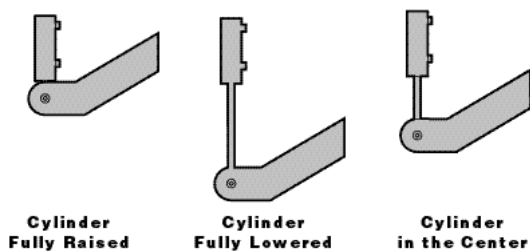

Figure 5.02b

Using the manual thickness adjustment cranks or hand cranks on the paver, null the screed and set the proper angle of attack. Next, turn on the auger feeder controls to place the asphalt in front of the screed.

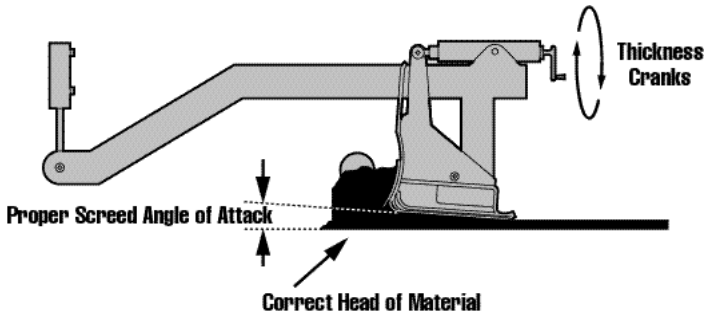

Figure 5.02c

Sonic Tracker Setup

When installing and positioning the Sonic Tracker II™, first connect the coil cord to the Tracker. Then bolt the Tracker to the bracket, and visually check to get the Sonic Tracker plumb.

Make one wrap of the coil cord around the "L"-Bar. This will act as a strain relief for the connector on the Tracker. Be sure the coil cord snap hook is in place and secure.

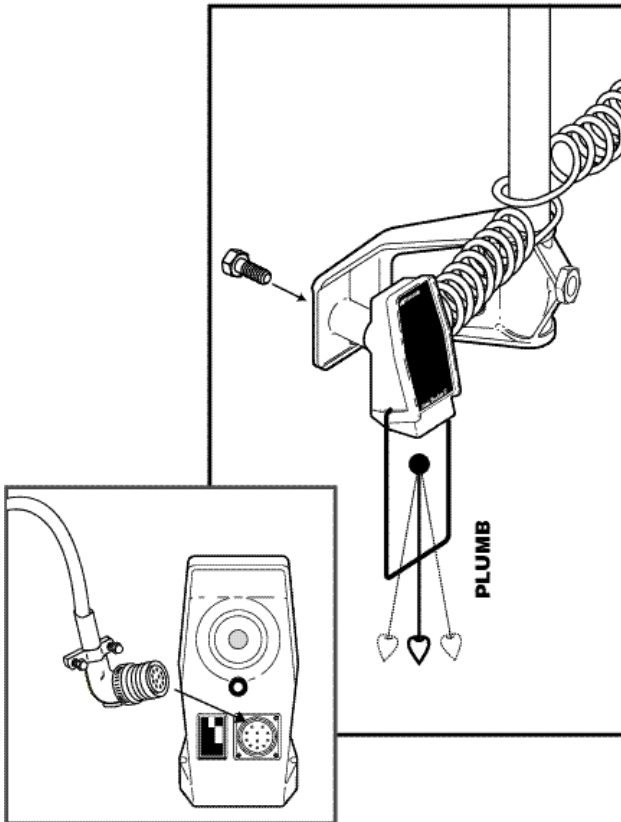

Figure 5.03

Control Box Setup - Elevation

Once the Sonic Tracker has been positioned over the reference, the Control Box can now set the Tracker On-Grade. Flip the power switch to the on position press and hold the survey button for 1 second until the box beeps and the green On-Grade Bar is displayed.

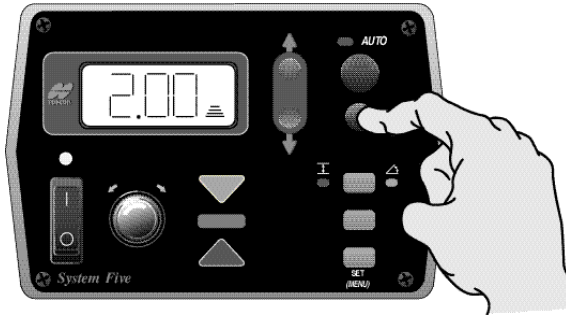

Figure 5.04a

Next, make the display read the same number as depth of mat to be laid. Press and hold the "Set" button with one hand. With your other hand, turn the grade adjustment knob to change the display to the height of the blocks under the screed. Release the "Set" Button and the value will be saved.



Figure 5.04b

Using Set will not change the existing mat thickness, it only changes the reference number viewed on the display.



Figure 5.04c

Press the Red Button and the Red LED will light up. You are now in automatic mode and can begin paving.

After you begin paving it is important to check the mat depth to insure the desired thickness is being laid. The blocks initially placed under the screed may cause the mat to be too thick or thin. Check the mat several times to get an average before making any corrections.



Figure 5.04d

If a 2.50 inch mat is required, but a 3.0 inch mat is being laid, then an adjustment is necessary. You must first get the box to display the same number as the mat depth. Press and hold the "Set" button with one hand. With other hand turn grade adjustment knob to read 3.0 inches. Press the red auto button to put the system back in automatic control.

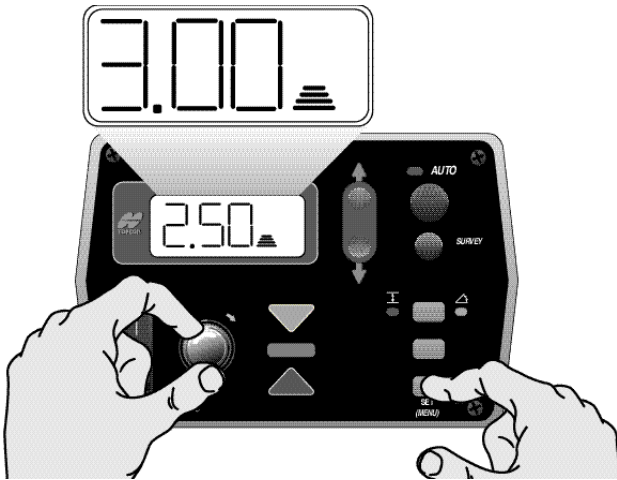

Figure 5.04e

With the paver moving and in auto, slowly dial the display from 3 inches down to 2.5 inches. How fast you turn the knob depends on how smooth you want the transition to take place. Highways require gradual changes, parking lot require quick changes. The display should now read the depth of the mat being laid.



Figure 5.04f

Control Box Setup - Cross Slope

The slope sensor should already be mounted on the transverse beam of the paver. The sensor can talk to both control boxes, but only one at a time. The sensor communicates to the Control Box through the cable.

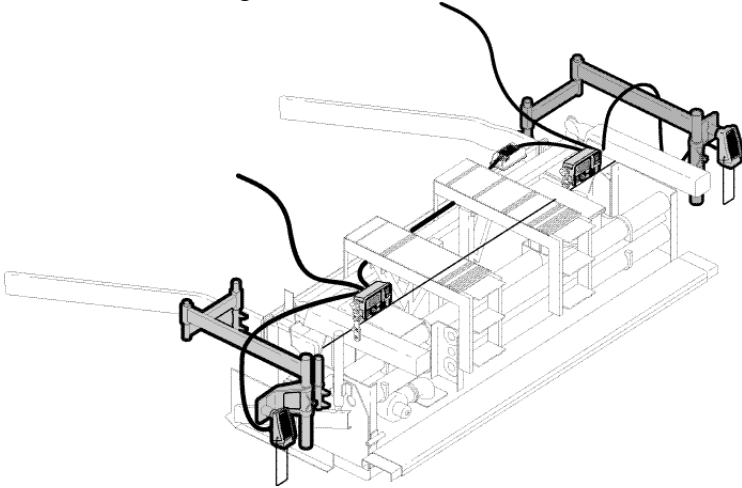

Figure 5.05a

To pave using cross slope you must first calibrate the slope sensor, to the screed. Find a smooth area where the screed can rest evenly across its entire surface. Using a laser, a Smart Level, or a slope board, that itself has been calibrated, check the cross slope and direction of fall of the ground.

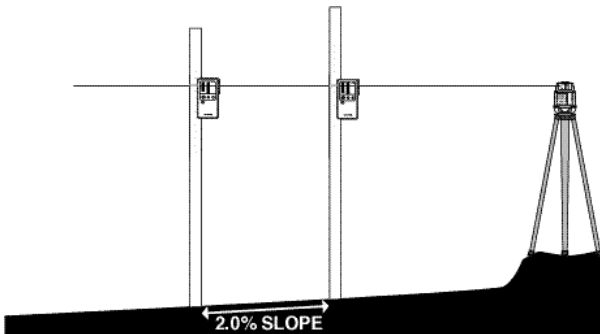

Figure 5.05b

Now place the screed on the ground and null it out. Flip the power switch to the On position and push the Slope Mode Button. The yellow LED next to the cross slope symbol will illuminate.

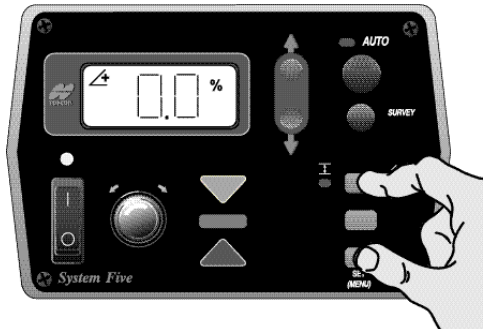

Figure 5.05c

To find out the slope and direction of fall the slope sensor thinks the screed is resting on, push the survey button for 1 second to lock sensor On-Grade. If the box is displaying an On-Grade bar and a slope value that is identical to the laser or Smart Level then you can begin paving. Make sure to push the Auto Button.



Figure 5.05d

If the slope displayed in the box does not match the surface, then the sensor must be calibrated. Press and hold the "Set" button with one hand. With your other hand, turn the grade adjustment knob to change the display to match the slope of surface. Release the "Set" button and the value will be saved.

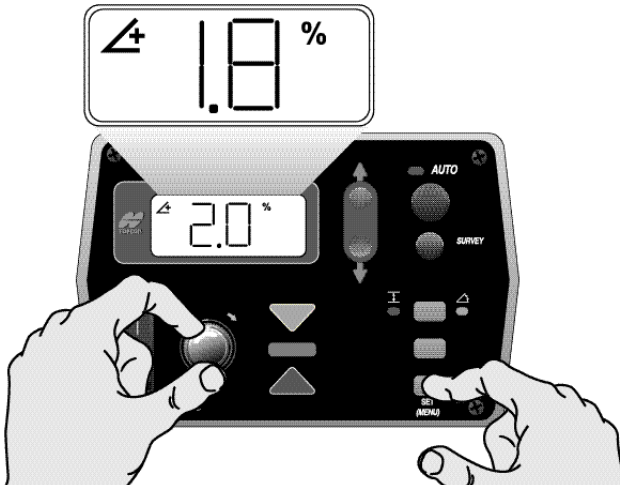

Figure 5.05e

NOTICE NOTICE

Using Set will not change the slope, it only changes the slope value viewed on the display.

Press the Red Button and the Red LED will light up. You are now in Automatic Mode and can begin paving.

Once the slope sensor is calibrated and you are ready to begin paving, you may find the existing surface does not have the same slope as the finish design. In order to produce a smooth transition, begin paving at the existing slope and slowly turn the grade adjustment knob to change the cross slope to the correct percentage.

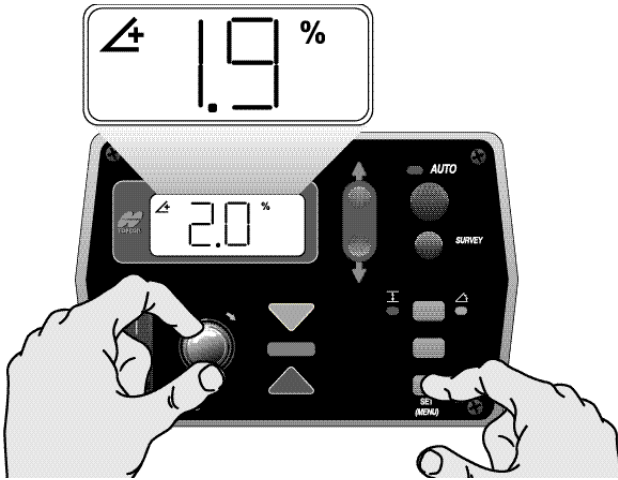

Figure 5.05f

If a smooth transition is not required, then dial in the desired slope and begin paving.

T racker Placement

Raise or lower the tracker bracket to position the tracker at the proper height above the grade reference. The tracker has a total working range of 14 to 55 inches. For paving applications the recommended working height would be from 14 to 24 inches. At 55 inches the sonic footprint would be very large and the tracker may pick up an undesired reference. The tracker also compensates for temperature changes only within the bail range. Placing the tracker too far from the reference may not allow for accurate temperature compensation.

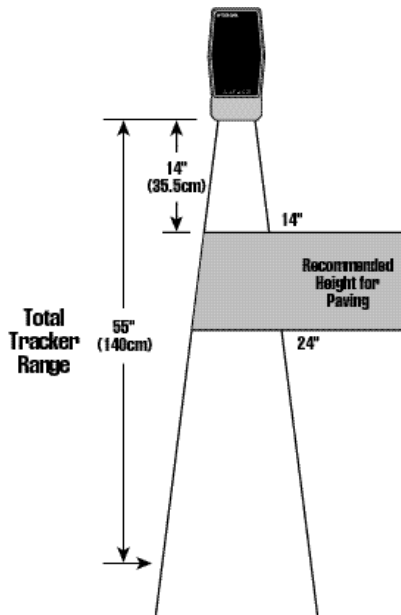

Figure 6.0

Position the "L"-Bar horizontally so the tracker will be over the reference. For example, when tracking a curb and gutter, place the screed or extension flush with the edge of gutter and slide the "L"-Bar so the Tracker is over the lip of the gutter.

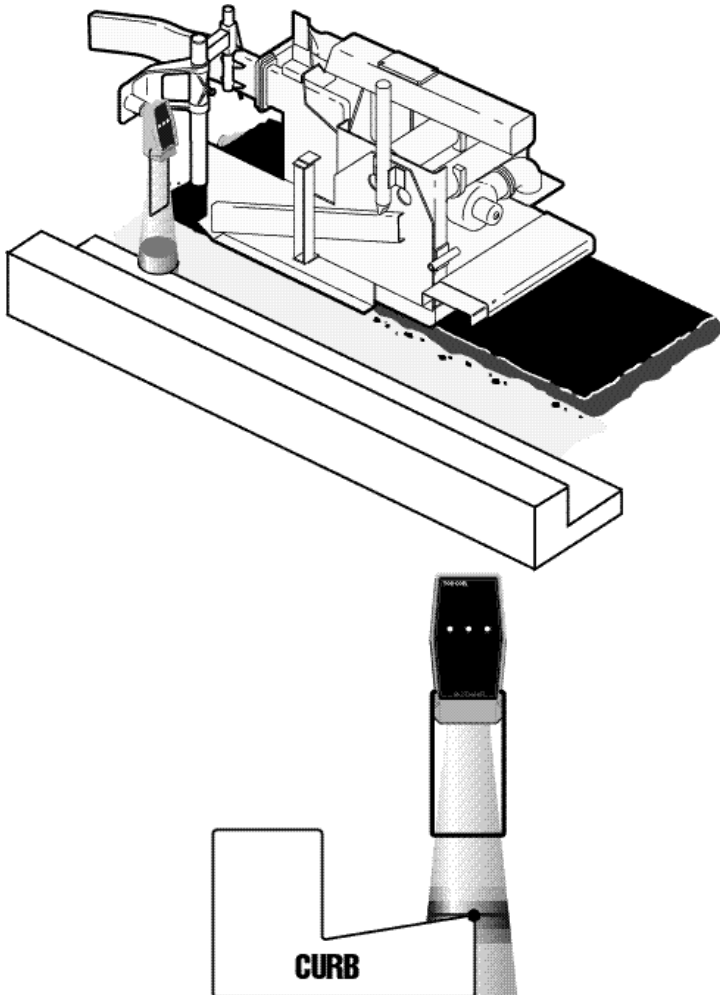

Figure 6.01a

The "L"-Bar can also be mounted to a bracket on the screed extension. This would work well in applications where the reference will not be a constant width and requires the extension to be moved in and out. Mounting to the extension will make it easier to keep the tracker over the reference.

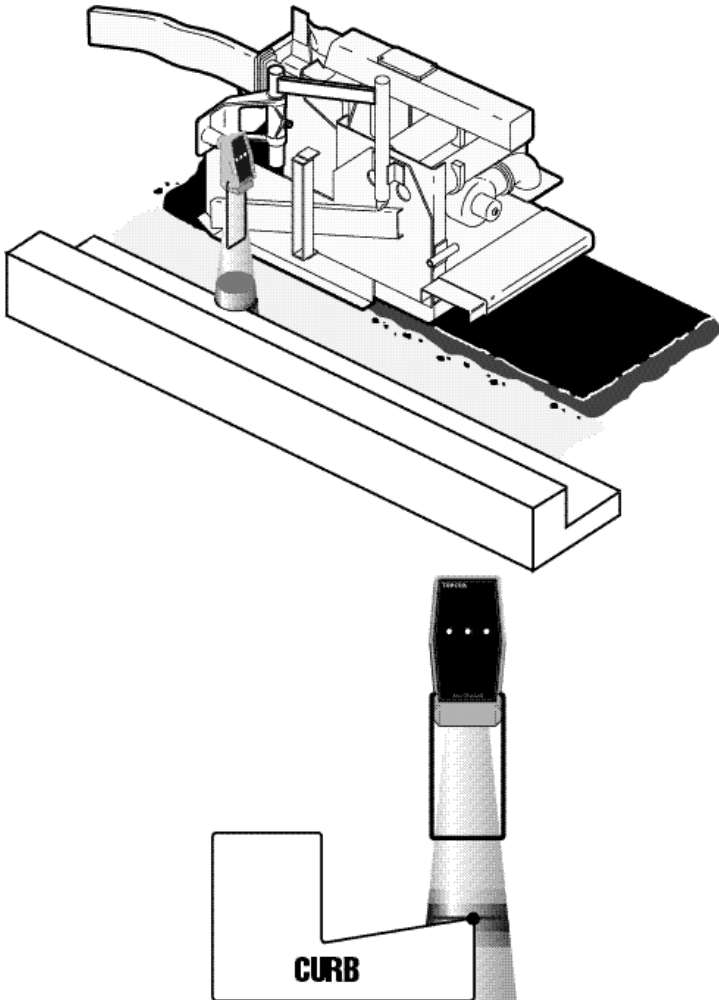

Figure 6.01b

When tracking a curb and gutter, keep the tracker 14 to 24 inches above the lip of gutter. If the tracker is placed too high, the sonic cone may pick up an unwanted surface, such as the face of the curb.

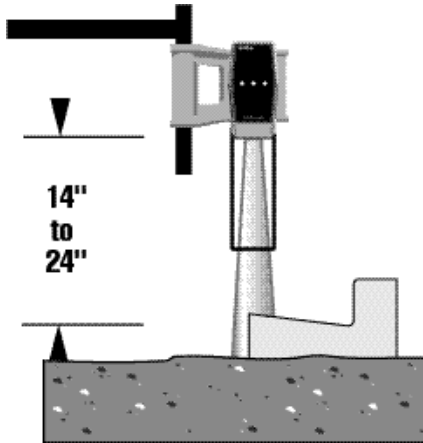

Figure 6.01c

For joint matching and tracking sub-grade or most surfaces keep the tracker between 14 to 24 inches. A good rule of thumb is to set the tracker about 18 inches from the reference.

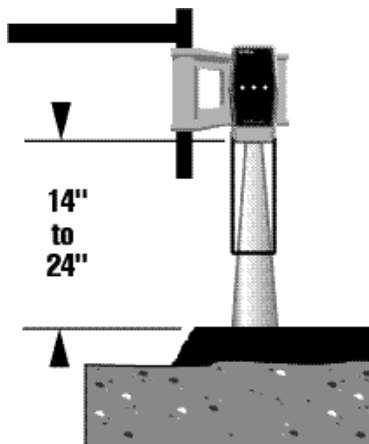

Figure 6.01d

If a mechanical ski with an elevated string or wire is being used, make sure the string/wire reference is a minimum of 4 inches above the ski. When paving with a mechanical ski through super elevations the ski will tend to pull away from the paver and may even tip to one side. Elevating the string at least 4" will insure the ski stays out of the working window.

It is also important to place the tracker in the center of the ski to maximize the averaging length. If you are using a 30' ski, then the sensor should be placed 15' from the end of the ski. For every 1' positioning error from the center of the ski, you lose 2' effectivity of the ski. An example of this would be if the sensor is moved forward or backward 2 1/2' (12 1/2' from the end) you are using a 25' ski.

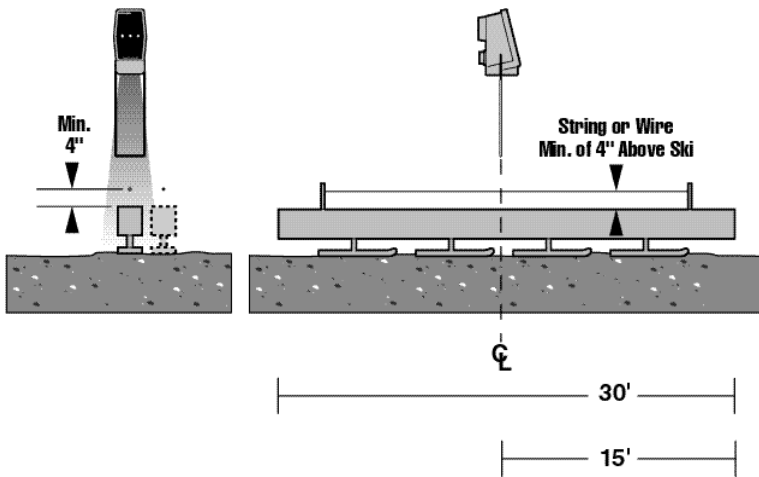

Figure 6.01f

Some jobs may require the mat be laid to a specified elevation. In an application like this an elevated stringline or wire may be set up. As was mentioned in the operation section, the sonic tracker has a built in working window that will prevent the screed from diving if the tracker loses the stringline reference. Position the tracker over the stringline and set the distance between 18 and 24 inches.

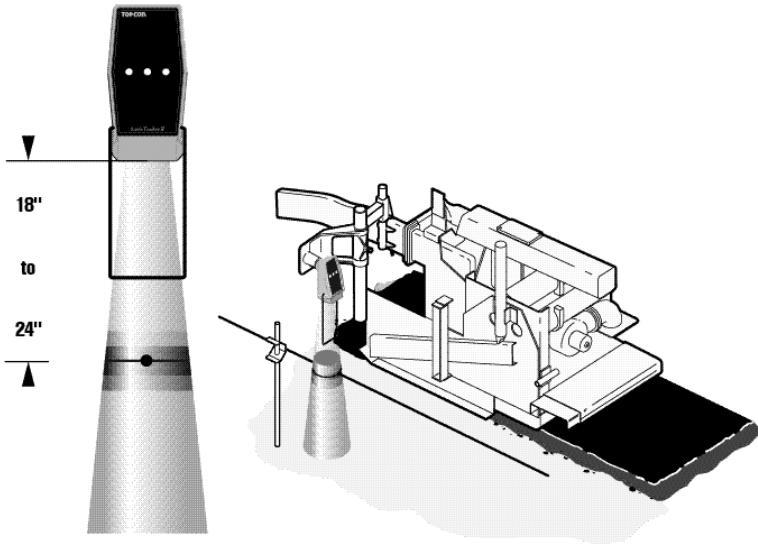

Figure 6.01g

Sometimes the surface to be paved contains pot holes or the surface is too broken up to use as a joint match reference. Setting an elevated stringline is too time consuming especially for small, divided up projects. In these applications, surface stringline would be a good alternative. (See section on Setting Surface Stringline).

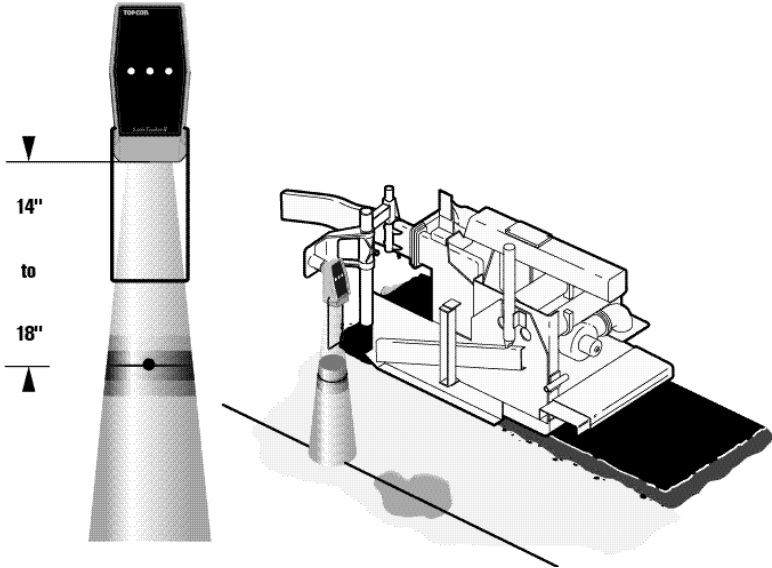

Figure 6.01h

We've discussed how far a tracker should be positioned from the reference, now we need to look at where the tracker should be placed in relation to the screed. As a tracker is moved closer to or further away from the screed, the response of the screed to an elevation correction changes. A rule of thumb is to place the tracker about 1/3 to 2/3 the length of the tow arm forward of the screed pivot point.

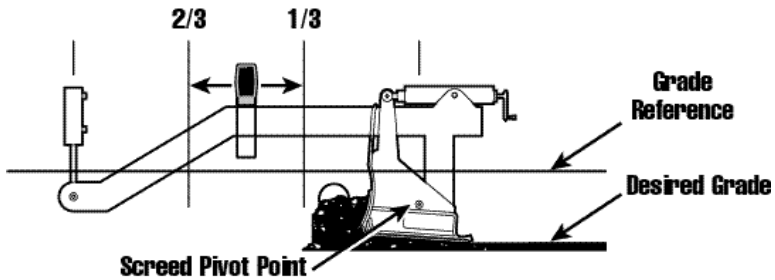

Figure 6.01i

If the tracker is not placed between these points then incorrect screed responses could result. Let's look at a couple of examples. If the tracker is placed directly at the screed pivot point, you can see exactly where the screed is relative to the grade reference. This is good, but the problem is we have no feedback from the tow point cylinder, which is what we are using to make the grade control changes.

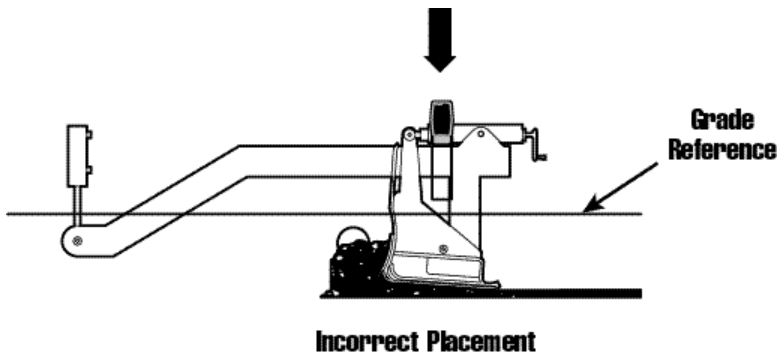

Figure 6.01j

If the tracker gets closer to the reference, it sends a raise correction signal to the valve and the tow point cylinder begins to move up. Because the screed floats it does not react immediately to the tow point movement so the tracker continues to send raise correct signals to the valve. By the time the screed gets to grade, (approximately 3 tow arm lengths) the tow point cylinder has moved too far causing the screed to continue raising. The tracker senses this over correction and sends a lower signal to the tow point cylinder, repeating the whole process in the other direction. Therefore, with the tracker mounted at the screed pivot point, long waves in the mat will be produced because there is no feedback from the tow point cylinder to the screed.

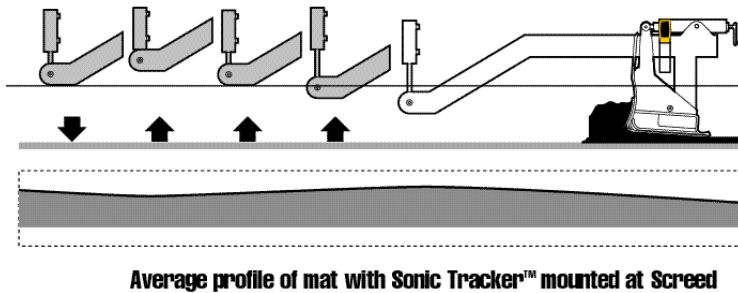

Figure 6.01k

To compensate for no tow point feedback let's place the tracker directly at the tow point where we are making the grade corrections. At this point we can keep the sonic tracker an exact distance from the grade reference. Any tracker elevation changes will cause the tow point cylinder to move right away.

The problem with the tracker placed here is we have no feedback from the screed.

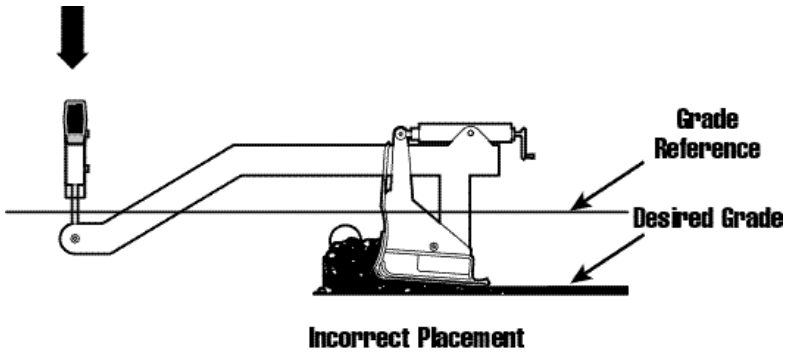

Figure 6.01l

If any of the forces acting on the screed change then the screed will rise or fall without the tracker sensing the movement. For example if the amount of material in front of the screed was decreased, the head of material force "M" also decreases and the screed would begin to fall. The sonic tracker would keep the tow point cylinder on grade, but not the screed since there is no feedback.

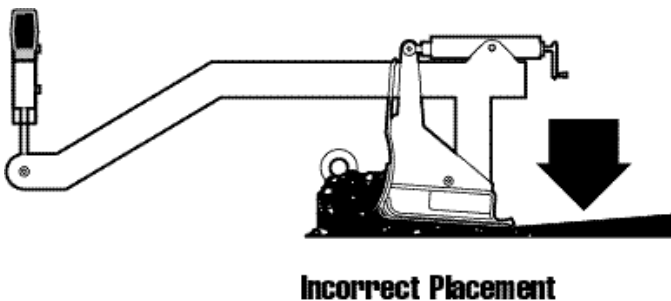

Figure 6.01m

The best place for the tracker is in the 1/3 to 2/3 zone, but where do we position the tracker within that area? That depends on what end result of paving you are trying to achieve. As the tracker is moved further back towards the screed it becomes more reactive. At the 1/3 point a 1/4 inch correction at the tracker will cause a 3/4 inch correction at the tow point. Another way to look at it is the "Net Tow Arm Length".

A paver with a 9 foot tow arm and no sonic tracker will take 27 feet (9 feet x 3 tow arm lengths) to see 96% of the elevation change. If a tracker is placed at the 1/3 point or 3 feet in front of the screed pivot point then the paver must only move 9 feet (3 feet x 3 tow arm lengths) for 96% of the elevation change. The tracker is measuring the distance to the reference so its position along the tow arm becomes the net tow arm length. A more reactive screed would be beneficial for applications where it is important to match the reference such as tracking a curb and gutter or matching a joint.

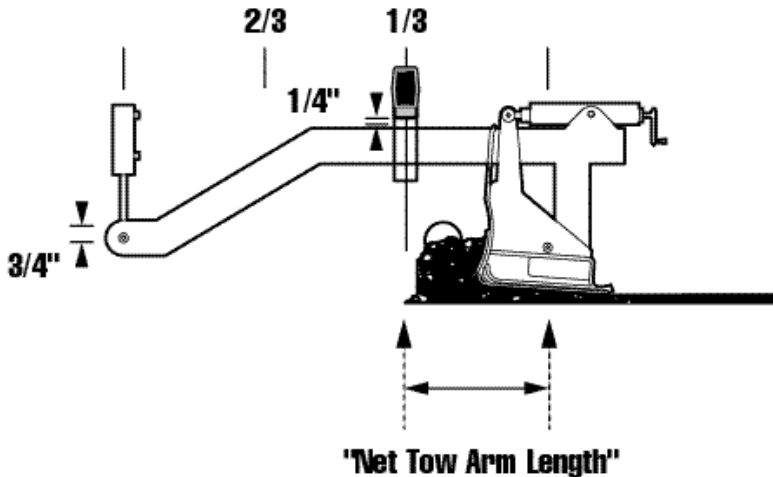

Figure 6.01n

As the tracker is moved further forward the screed becomes less reactive. A tracker placed at the $\frac{2}{3}$ point and looking for a $\frac{1}{4}$ inch correction will only cause the tow point to move $\frac{3}{8}$ inch. The net tow arm length is now 18 feet (6 feet x 3 tow arm lengths). This would be a better tracker position for applications where smoothness is desired such as mainline paving or when using a mechanical or non-contacting (SAS) ski.

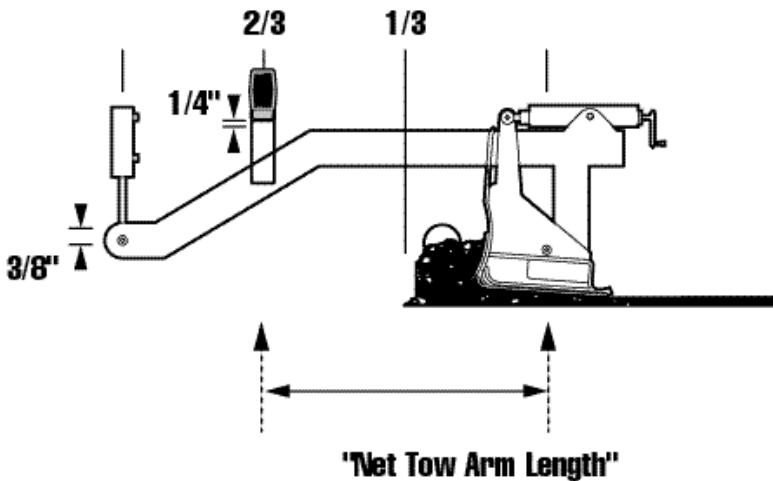

Figure 6.01o

Stringline

Setting Surface Stringline

Surface Stringline is a great replacement for a contacting averaging ski, or where no reference is available or practical. The purpose of a ski is to average out the irregularities of the surface being paved. Although a good idea in principle, averaging skis seldom work well in practice. They are bulky, complex, cumbersome and get broken easily. When they are working they still only average over their length.

Surface Stringline is better. As a Surface Stringline is stretched over the ground it levels out the high places and bridges the low, creating a very natural average over a distance as long as 500 feet. Since the Sonic Tracker II™ is non-contacting, it can track Surface Stringline without deflecting it, producing an extremely smooth surface. Additionally, the smoothness of the surface you will get from Surface Stringline is verifiable before you begin paving. Just sight down the string and you can see how good the job will be. If there will be problem areas, mark the spots and either fix them ahead of time or use the marks as a "I told you so" for future reference. You can also use the same Sonic Stringline as a steering guide.

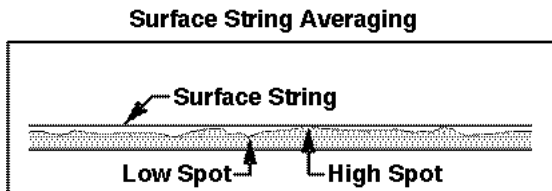

Figure 7.0

Position the tracker 14 to 18 inches above the stringline.

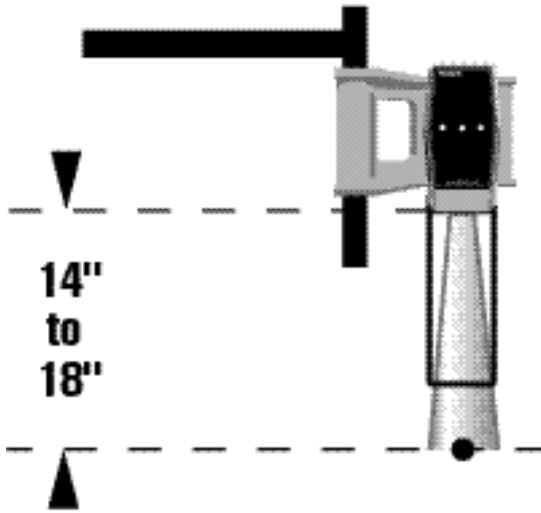

Figure 7.01a



NOTICE

It is important to use a stringline with a diameter at least 1/8" thick. The sonic tracker can detect a smaller diameter stringline, but when stretched on the surface to be paved the surface below the stringline will be within the working window so you want to make sure you have a strong return signal.

To setup surface string, simply drive a concrete nail into the existing surface to be overlaid and tie the stringline to the concrete nail.

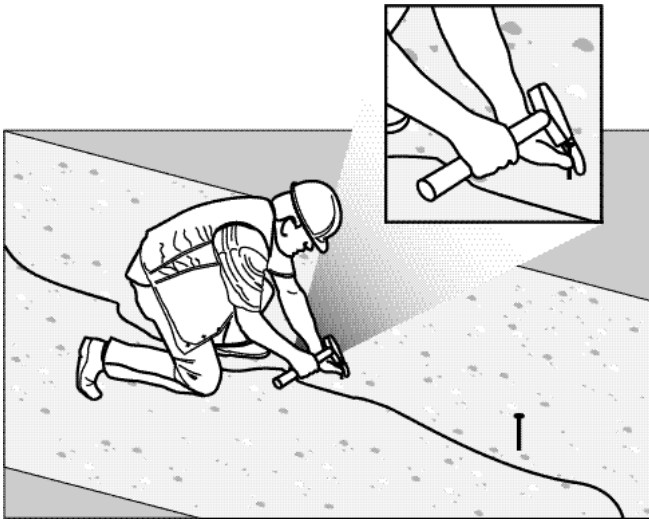

Figure 7.01b

Roll out the stringline to the desired length. Pull tight and secure to another nail at the opposite end.

The tightened stringline will rest right on top of the existing surface.

When the sonic tracker sends out a sound wave, the first thing the tracker sees will be the reference stringline.

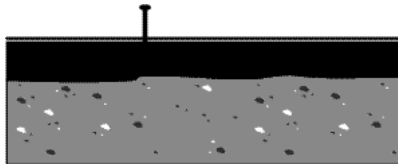

Figure 7.01c

Since the stringline has been pulled tight, any small variables in the existing surface will be bridged. You now have 500 ft. ski.

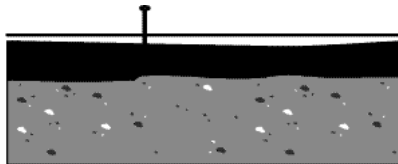

Figure 7.01d

The operator may use the surface stringline for steering and grade control.

Trucks and other traffic can drive right over the top of the surface string with out causing any grade control problems or damage to the reference

7-4 The surface stringline is a verifiable grade reference, what you see is what you get. Any potential problems can be pointed out to the inspector before you pave. Try it, it really works!

Setting Elevated Stringline

On some projects the asphalt must be laid to a specified elevation. For this application an elevated stringline must be set. The stringline will usually be set up at a 1' or 2' "hike up" from finished grade. The stringline is set referencing hubs or lath placed by the surveyor.

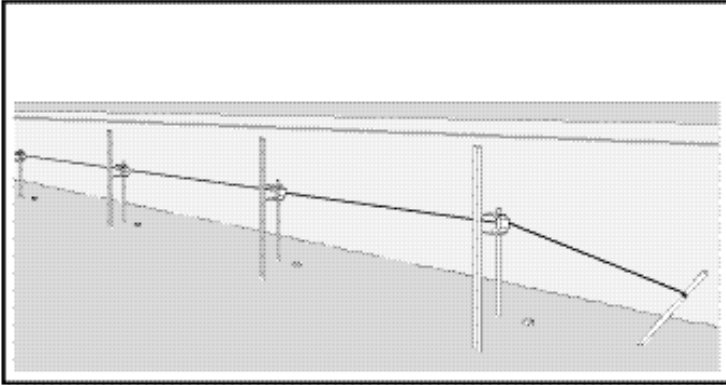

Figure 7.02a

Sonic Stringline provides an inexpensive, easy to set up, continuous reference that takes the best advantage of the non-contacting feature of the Sonic Tracker II™. By taking a few minutes to set up a stringline the Tracker can transfer grade to the paver 39 times per second! The stringline also becomes a great visual reference for the job. Any mistakes in a hub elevation can be quickly spotted by just sighting down the string.

Available From Your Topcon Dealer:

TOPCON Part #	Description
7020-0101	Sonic Stringline, 1000' Roll
7020-0121	Sonic Grade Clips, Box of 100
7000-1026	Cut/Fill Offset Tape (Feet Tenths)
7000-1027	Cut/Fill Offset Tape (Metric)

Figure 7.02b



NOTICE

Although Topcon's Sonic Tracker will work with many sizes and types of stringline, for best results we recommend an 1/8 inch diameter nylon stringline. Using steel wire or a plastic coated stringline with a smooth surface is **not** recommended. If the Tracker will track the ground, but will not track a 1/8 inch diameter stringline, clean or replace the transducer.

1. Place the Sonic Grade Clips on stakes and drive the stakes approximately 6 to 8 inches away from, but in line with, the hubs (Do Not disturb the hubs).

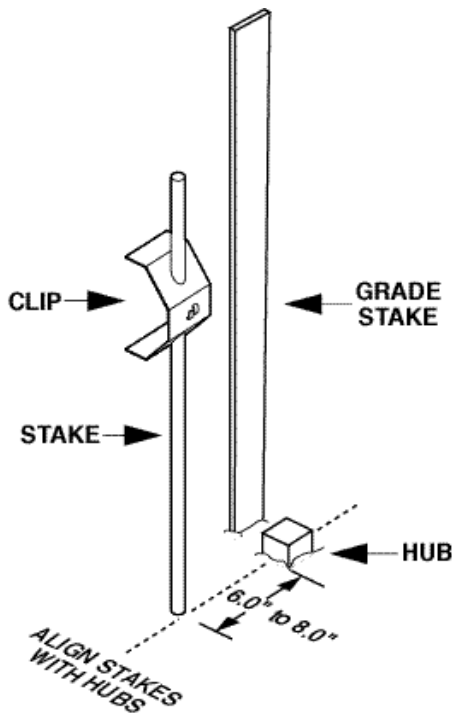

Figure 7.02c

2. Using an anchor pin at each end, roll out the Sonic Stringline the length of the working area and pull the stringline tight.
3. **After** the stringline has been pulled tight, place it into the "fingers" of each Sonic Grade Clip.

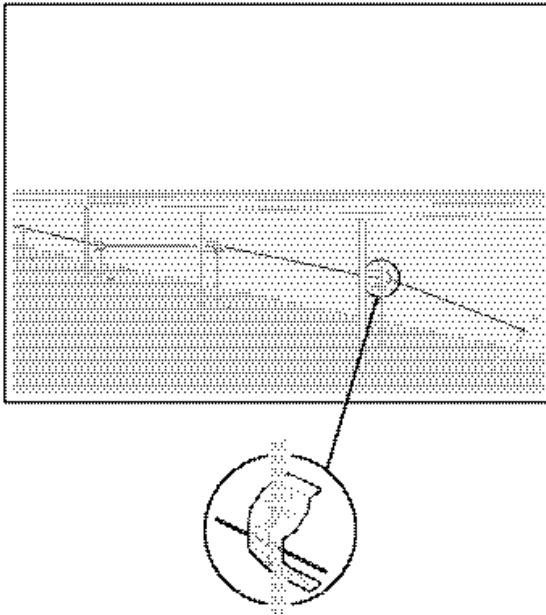

Figure 7.02d

4. Decide what the Sonic Stringline hike-up (the distance from Finished Grade to the Sonic Stringline) should be: in this case, 2 feet.

Make a cut/fill lath using a lath and a Topcon Cut/Fill Decal.

Measure, from the bottom of the lath, the desired hike-up and make a mark at that point. Place the Cut/Fill Decal on the lath with "0" on the point you marked.

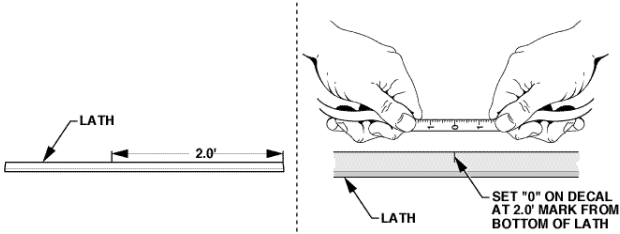

Figure 7.02e

5. Next, set the cut/fill lath on the hub and read the cut or fill from the grade stake next to the hub. Adjust the clip up or down until the stringline crosses the cut/fill lath at that point.

A cut of .25 feet

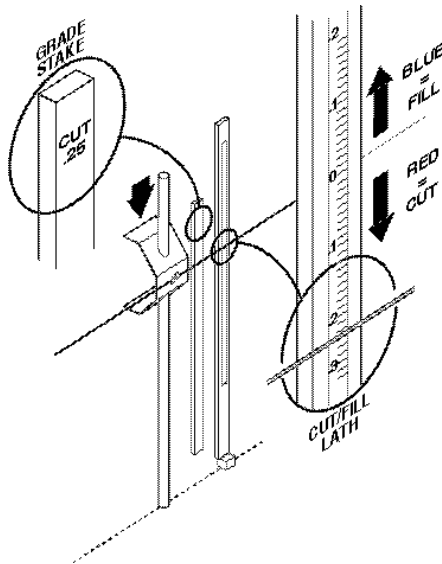

Figure 7.02f

- The stringline is now set to 2 feet above finished grade.

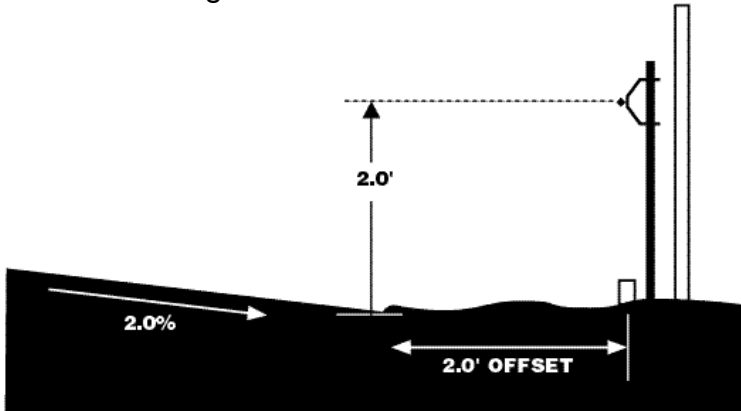

Figure 7.02g

- Repeat this process at each station before starting to pave.

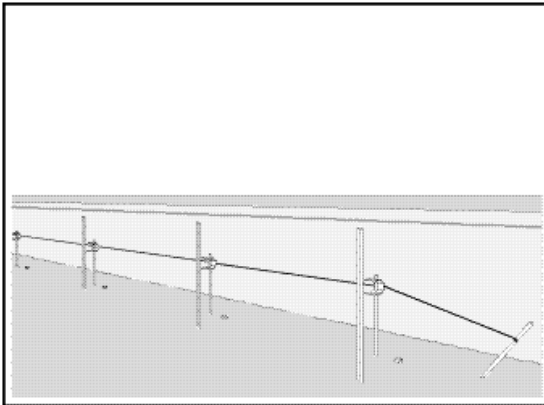

Figure 7.02h

- **Setting Stringline to Projected Slope**

Jobs with slope transitions or super-elevations must have the stringline set to the “projected slope”. Failure to do this will produce an elevation error at the edge of the road as the slope is changed. To set the stringline to the projected slope, first set up the string at the desired hike up as shown in the previous pages. Next, raise or lower the stringline to compensate for the % slope and the distance from edge of the road to the stringline. [RISE = (RUN)(%)]. If the road is rising away from the stringline, the stringline will need to be lowered. If the road is sloping down from the stringline, the stringline will need to be raised.

This adjustment is needed at each station.

- Example: 2.0% Cross Slope with 2 feet offset.

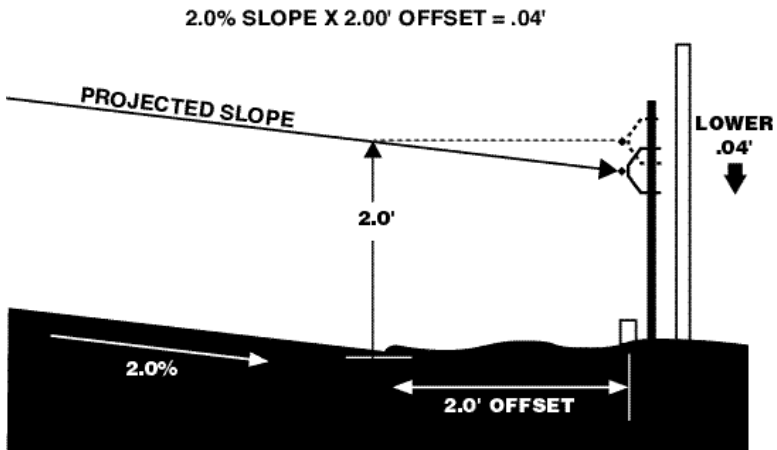

Figure 7.02i

- Example: 3.0% Cross Slope with 2 feet offset.

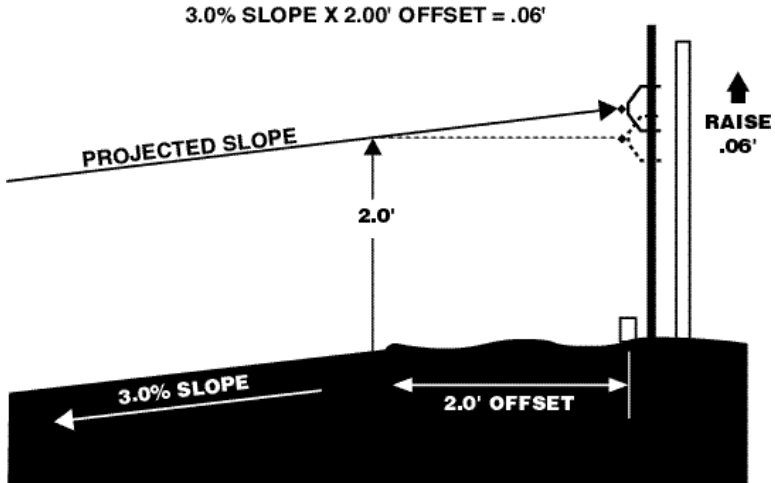

Figure 7.02j

On some jobs, it may be more practical to secure the stringline directly to the grade stake next to the hub. First, mark the lath with a 2 or 3 feet “hike up” or boot” above grade, just as you would to check grade with an eye level or pulling a string across the street.

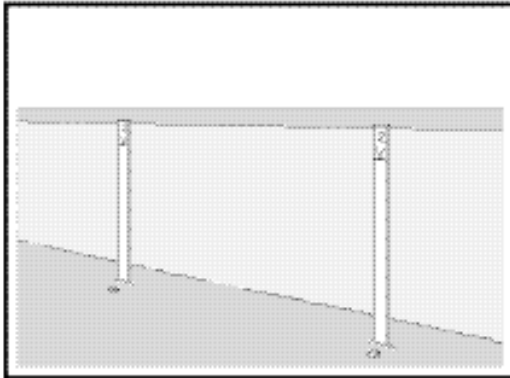

Figure 7.02k

Secure an anchor pin at each end of the stringline and pull the stringline tight. At each station, staple or ty-rap the stringline directly to the witness lath so the stringline is at the desired hike-up.

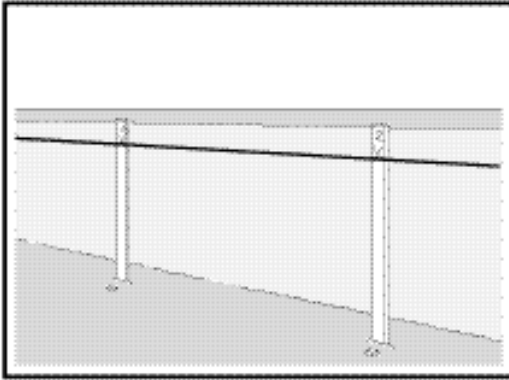

Figure 7.021

Due to the height of some stakes the Tracker may need to be raised or the tops of those stakes may need to be cut off.

- **Making a Grade Verification Lath**

Verifying grade requires measuring the distance from the asphalt to the Sonic Stringline. Because the hubs are offset from the edge of road and the Sonic Stringline is a predetermined “hike-up” above Finished Grade, a simple tool called a “Grade Checking Lath” can be constructed. This can be easily done using lath, a level bubble and simple hand tools.

In this example assume that the hub offset from the edge of road is 1.5 feet and that the “hike-up” is 2.0 feet. Construct a Grade Checking Lath as shown below.

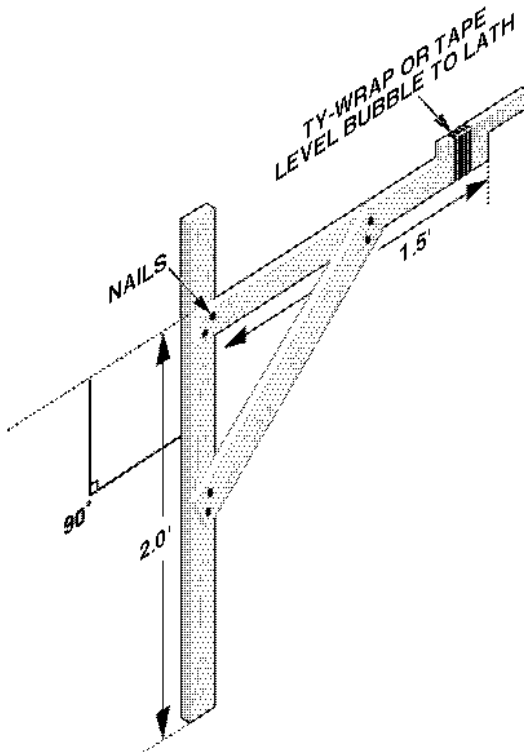

Figure 7.02m

- **Verifying Grade**

To verify grade, set the Grade Checking Lath on the newly laid mat edge so that the level bubble extends over the Sonic Stringline shown below.

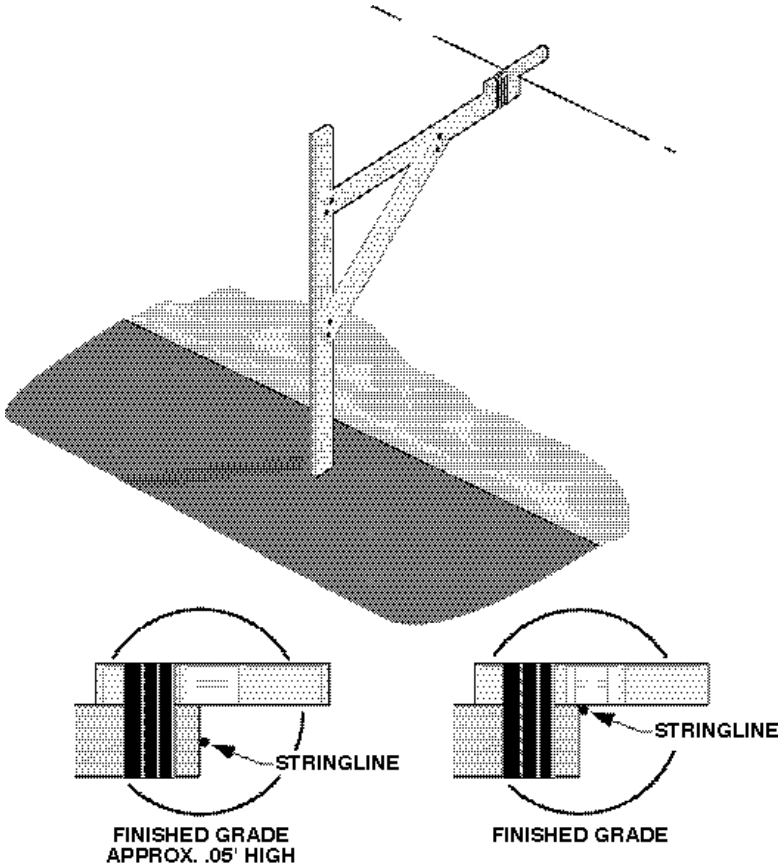

Figure 7.02n

Tilt the Grade Checking Lath until the level bubble is centered. Finished Grade is correct when the level just touches the Sonic Stringline.

Smoothtrac® (SAS) Set Up

Topcon's Smoothtrac® is a non-contacting averaging system that uses multiple sonic trackers to smooth out the bumps and dips in a mat surface. The non-contacting design allows full maneuverability of the paver when turning around, backing up or passing over obstacles without lifting or removing the beam. The screed man can adjust mat thickness on the control box while standing on the screed. The Smoothtrac® is mounted to the tow arm of the paver, and connects to System Five™ with the same coil cord used for the Sonic Tracker.

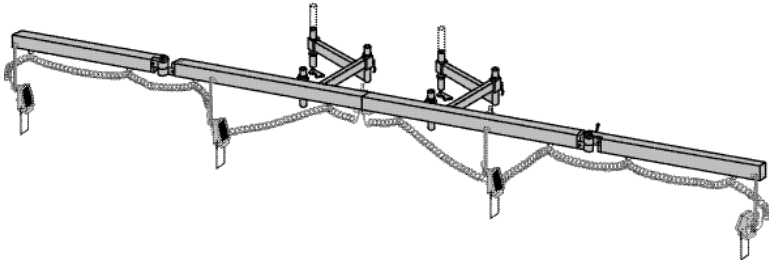

Figure 8.0

When mounting the SAS to the paver there are a few simple steps to follow. First, if the ski is not in one piece, connect both halves together.

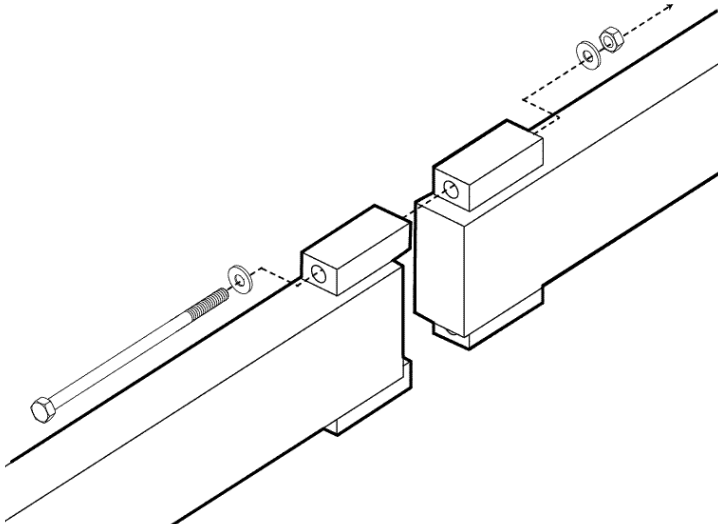

Figure 8.01a

Next, mount the "L" bars to the brackets on the tow arm. The outside "L" bar can be attached so it points up or down. The position will depend on how tall the tow arm is off the ground. For pavers with a tall tow arm, mount the "L" bar in the downward position. For shorter tow arms, mount in the upward position. Place locking collars on bars and adjust so they are parallel with one another before tightening with an Allen wrench. This will allow the ski to move freely when adjustments need to be made without falling off.

Bend "L" bars so they are aligned in the same position and fold inwards so they are close to the paver. Make sure clamp handles are loose so bars can move.

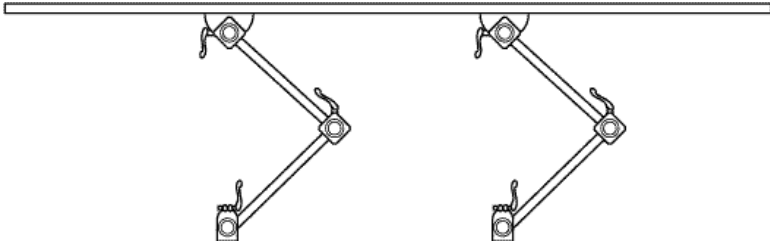

Figure 8.01b

Lift ski and slide over "L" bars. Adjust the ski so it is approximately 2 1/2 feet off the ground. Slide the locking collar to the ski and lock in place. Helpful hint, the ski will be easier to mount if the end beams are folded in. Bend "L" bars so they are aligned in the same position and fold inwards so they are close to the paver. Make sure clamp handles are loose enough so bars can move.

Lower each of the Tracker hangers on the SAS and mount a Sonic Tracker using the "L" handle bolt. An extra washer may need to be added so the "L" handle does not block the cable connection.

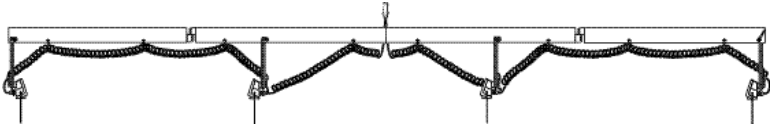

Figure 8.01c

Connect the SAS coil cable to each tracker to the Sonic Tracker coil cord. Make sure to loop the coil cable through the "U" hangers to keep it from getting damaged. Don't forget to install temp bails before paving!

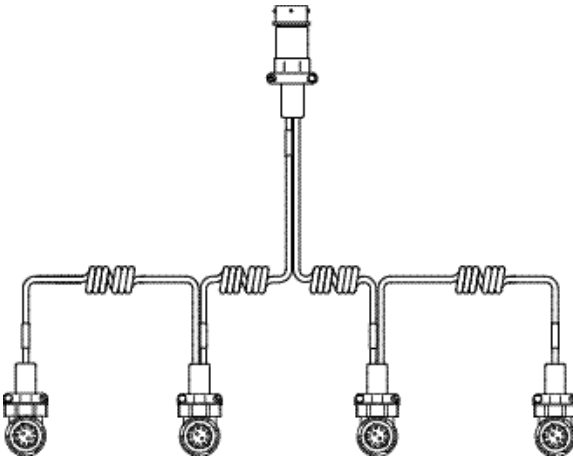

Figure 8.01d

Positioning the SAS

The SAS should be positioned so the Sonic Trackers are 14 to 24 inches from the grade reference. As with single tracker operation, the "lower the better" is a good rule of thumb for paving applications. This will help minimize the variable temperature conditions that can cause erratic signals. The beam does not have to be perfectly level because each tracker averages the distance to the reference individually.

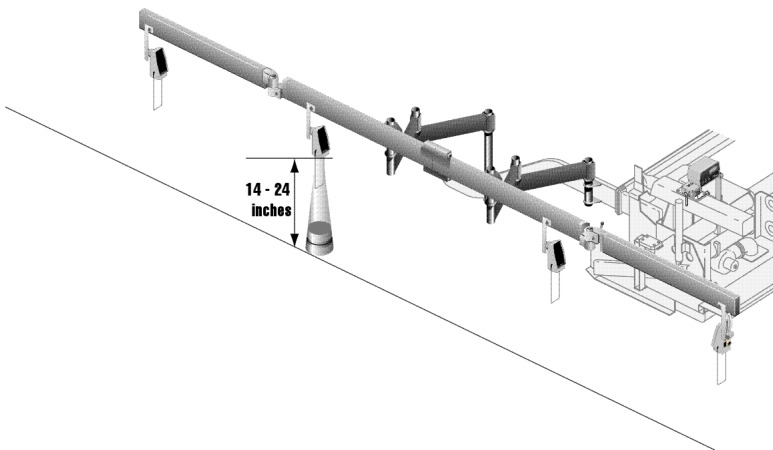

Figure 8.02a

With SAS be careful when the screed is raised, that the front tracker does not hit the ground. If needed the tracker bracket can be folded back when raising the screed to keep the tracker from hitting obstructions.

The trackers can be placed so all four are over the reference, or the back tracker can be set over the freshly laid mat. The best method is the one you are presently using or the one in which you are most comfortable.

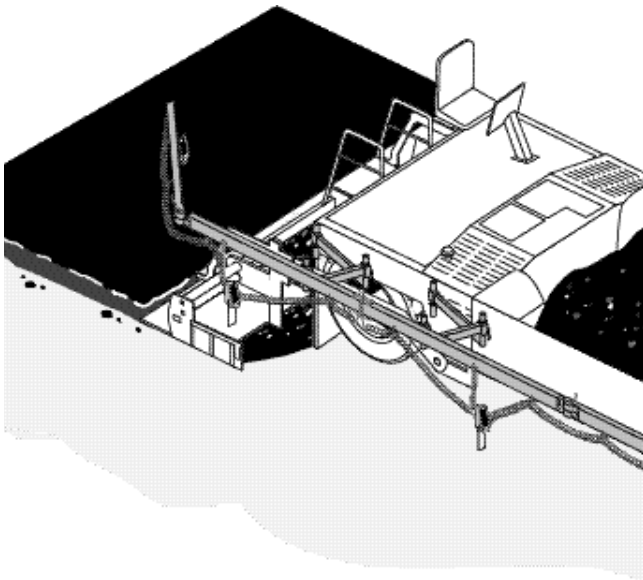
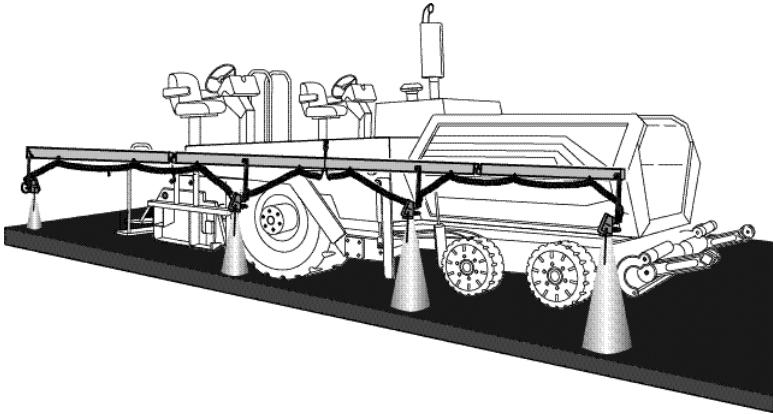

Figure 8.02b

In some applications the grade reference outside the screed extension may not be in satisfactory condition, such as the shoulder of a road or the broken and warped edge of pavement. Traditionally the screedman would manually adjust mat thickness on that side of the paver. The non-contacting SAS can be set up over the screed so full automation can be used. The first three trackers will reference the existing grade and the back tracker will reference the mat just laid.

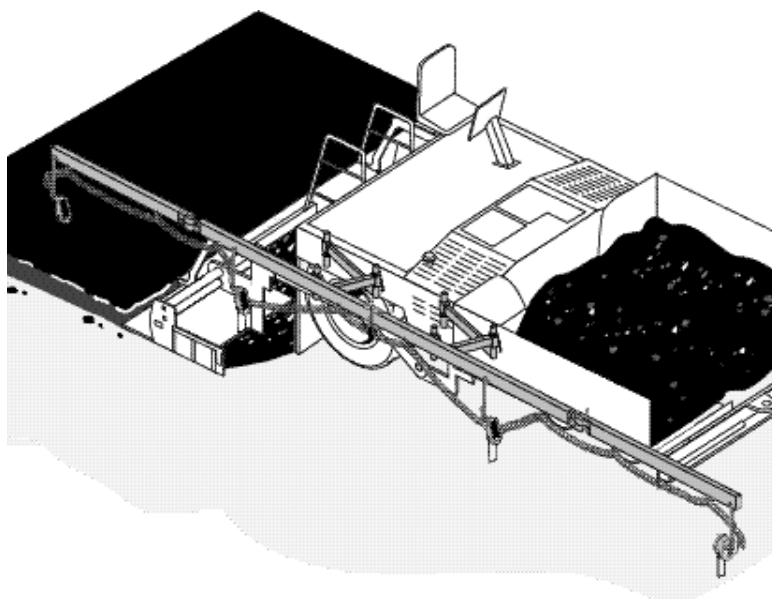

Figure 8.02c

When paving with the screed extensions out, there may be a large "head of material" which could be picked up by the Sonic Tracker. If this happens determine how far forward the tracker must be placed on the beam to not pickup the mix and drill a new mounting hold for the tracker hanger. The SAS coil cable will easily reach the tracker.

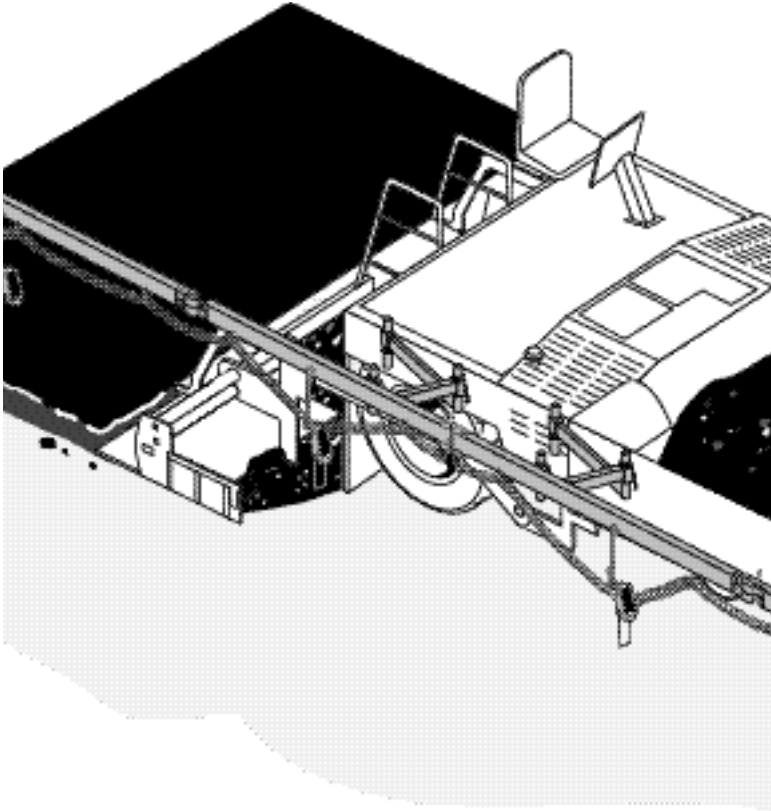

Figure 8.02d

Placement of Sonic Averaging System

The center connection point of the SAS is the balance point. The position of the balance point to the tow arm is very critical. By moving the balance point, the performance of the system is greatly affected. The balance point of the beam should be located $1/3$ to $2/3$ the distance from the pivot point of the screed to the tow point cylinder.

Placing the balance point closer to the $2/3$ point (near the tow point cylinder), will cause the system to have a slower reaction time. This would be good for smoothness or for mainline paving. Placing the balance point near the back $1/3$ (closer to screed) will cause the system to have a faster reaction time. This would be good for a combination of smoothness and joint matching.

To determine where to position the SAS on the paver, start by measuring the length of the tow arm. Divide the total length by three. This will give you the placement of the balance point of the SAS on your machine.

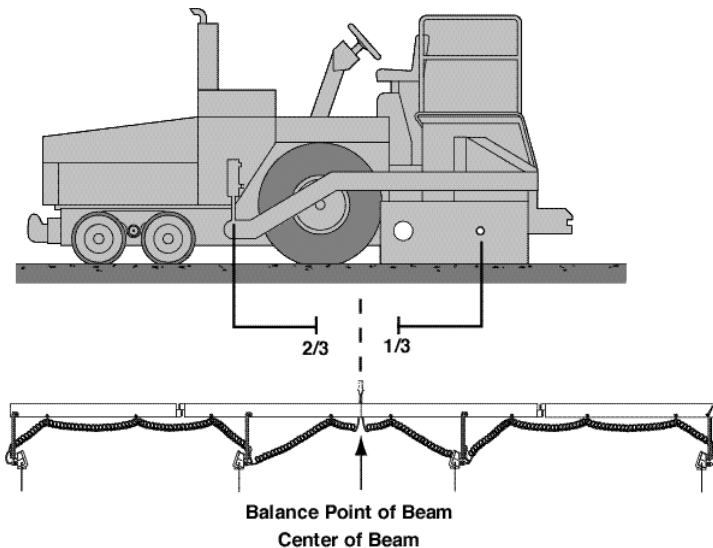

Figure 8.03a

Once the SAS has been installed, the System Five control box will automatically configure for SAS when powered on. The box will check to see how many trackers are connected and average over that amount.

Getting the System Five Box ready to pave is the same as with one tracker.

1. Block screed for required mat thickness
2. Center hydraulic rams
3. Null screed and turn on augers to place material in front of the screed
4. Place trackers over reference
5. Push survey button on Box to lock trackers On-Grade.
6. Push and hold set button while dialing in mat depth.
7. Put Control Box in Auto and begin paving.

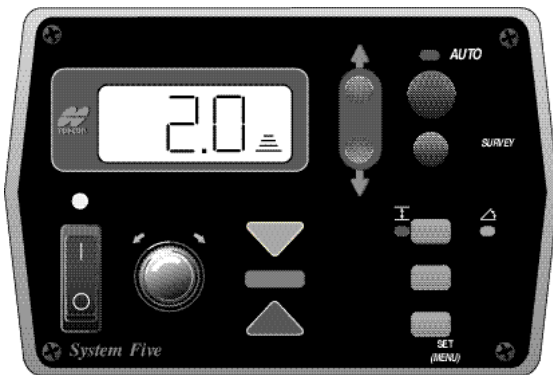

Figure 8.03b



NOTICE

It is not necessary to start paving in manual as is traditionally done when using a mechanical ski. If the setup procedures are followed correctly, paving with the SAS can and should start in automatic.

The SAS system has been designed to discontinue operating when one of the Trackers fails. When a failure occurs, the control box will flash "ERR" followed by a number from 1 to 4. The number represents the Tracker which failed, making troubleshooting easy and fast.

To reset the control box once a new tracker has been installed, or if the tracker has been removed and only three trackers will be used, turn the power off then on. The control box will reconfigure to the number of trackers. Changing the number of trackers may change the average distance. Resurvey the Control Box to lock SAS On-Grade.

Once one of the Trackers has been eliminated from the averaging, the balance point of the beam will have changed. If the faulty Tracker is not replaced the beam will need to be repositioned to adjust for the new balance point. It is strongly recommended, if the first or last Tracker fails, to replace it with one of the Trackers from the middle of the beam. This will insure that the balance point is not outside of the 1/3 to 2/3 rule.



NOTICE

A number reading of "1" could mean the first or last Tracker has failed depending on which side of the paver the beam has been mounted. The SAS cable is labeled with numbers at each connector for easy identification.

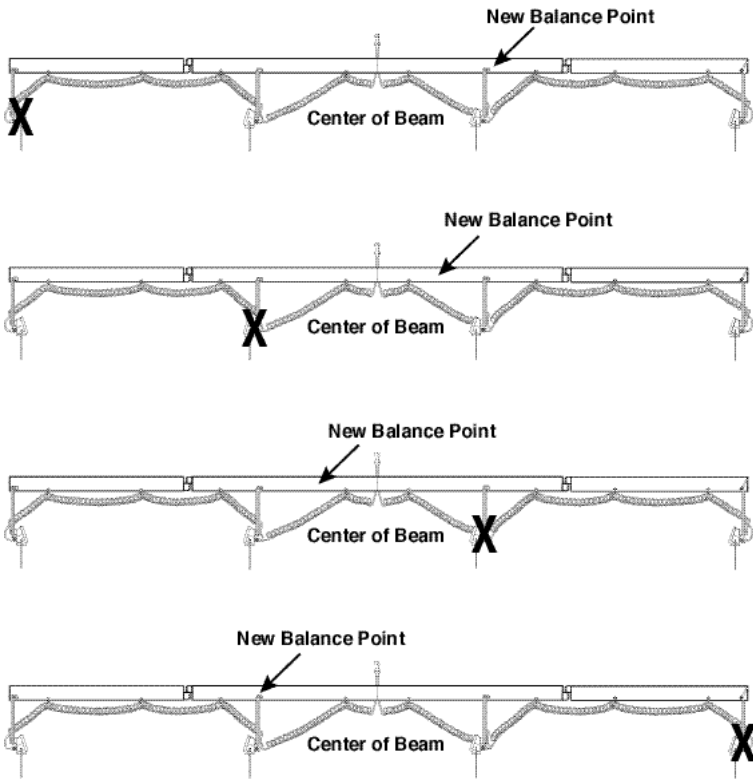

X = Indicates Tracker has been removed.

Figure 8.03c

Applications

What type of controls you should use for paving depends on what result is required for the finish product. Some projects are looking for smoothness and improved rideability. Others are concerned with mat thickness and some require the new asphalt to match curb and gutter or existing grades. Topcon's System Five is very versatile and can be used in all these applications. The following are a few examples of what controls might be used and how to set them up.

Paving City Streets with Sonics

When paving city streets the general requirement is to lay a mat that is so many inches above the base at the centerline and to match curb and gutter. For this application sonic control will be used on both sides.

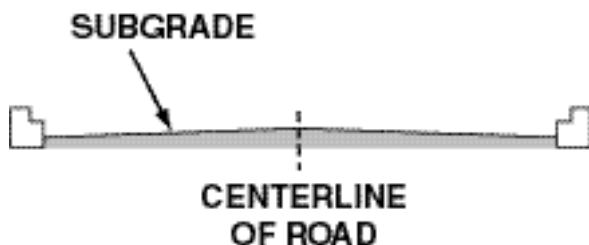

Figure 9.01a



NOTICE

Before paving make sure the machine is properly setup, cross slope is calibrated and trackers are set in the correct position. (See Chapters - Getting Ready to Pave & Tracker Placement.)

Position right Tracker over lip of gutter and left Tracker past the centerline on the base material.

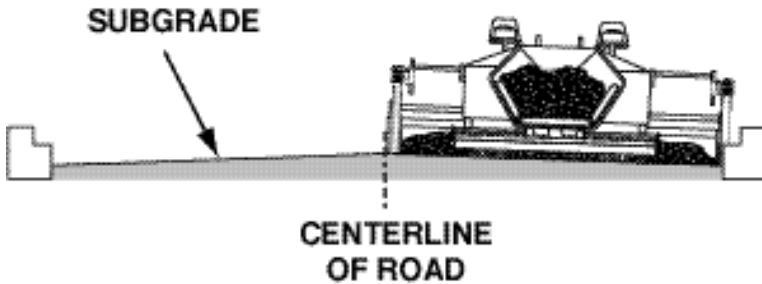

Figure 9.01b

Turn Boxes on, then "Survey" and "Set" the displays to read the depth of asphalt to be laid.



Figure 9.01c

Put boxes in Automatic and begin paving. Check depth of mat at centerline and verify joint is matching at lip of gutter. After compaction make necessary adjustments on the Control Box.

NOTICE NOTICE

If the road width varies, it will be easier to keep the Tracker over the gutter if the Tracker is mounted to the extension on the paver.

To pave the other side of the road, position the left Tracker over the lip of the gutter and place the right Tracker over the new mat.

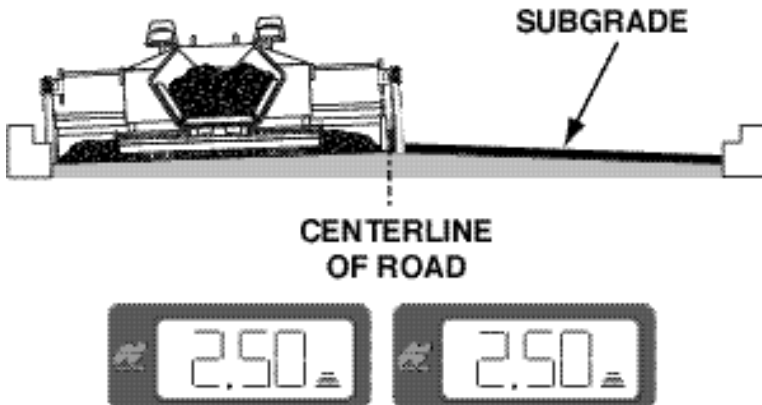

Figure 9.01d

"Survey" boxes On-Grade and "Set" the displays to read the depth of asphalt to be laid. Put boxes in Automatic and begin paving. Check to make sure joints are matching after compaction.

Paving City Streets with Cross Slope

Another option is to pave the street using cross slope and sonic control. The Tracker is positioned over the lip of gutter on one side and cross slope is dialed in for the crown on the other. This method may have to be modified due to the fact that in many cases the curbs may be poured at different elevations across the street. Even though the curb was poured out of tolerance, it may have passed inspection and the asphalt needs to match the curb and gutter. If the curbs are at different elevations, it is impossible to pave a typical design slope on both sides of the street.

A cross section design of a 36 feet wide street with a 2.0% slope will produce a .36 feet rise at centerline.

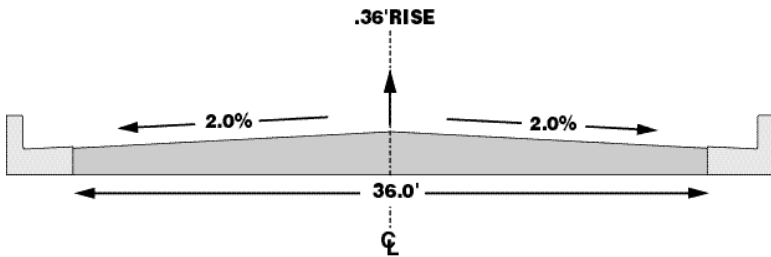

Figure 9.02a

If the curbs are at different elevations, a .36 feet rise at centerline will produce incorrect slopes.

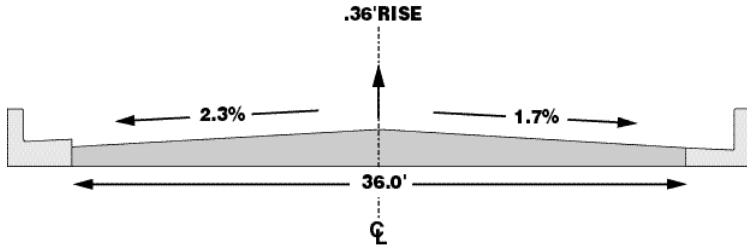

Figure 9.02b

When System Five™ is used to pave a true 2.0% slope, the crown of the street will not be at the centerline.

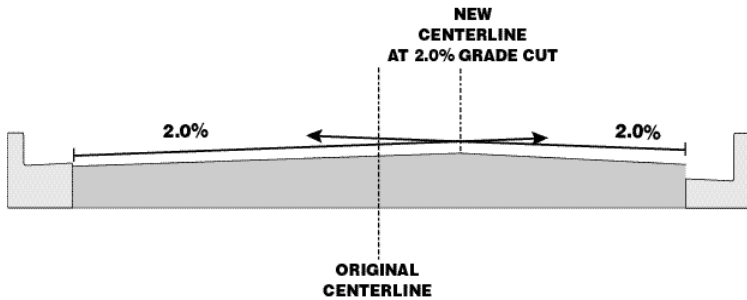

Figure 9.02c

To pave from uneven curbs using slope control choose the side of the road with the highest curb and position the tracker over the curb. Set the other side for the desired cross slope and begin paving.

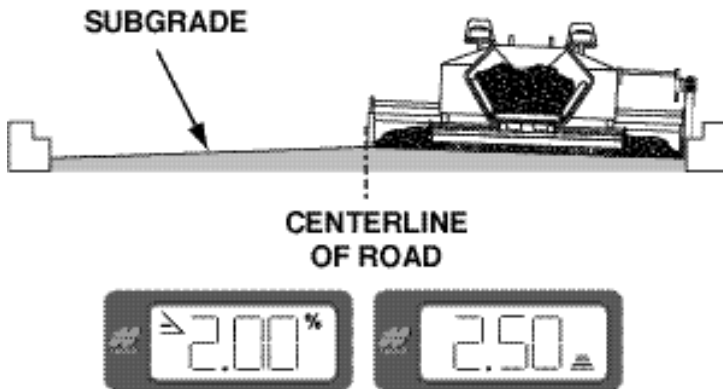

Figure 9.02d

To keep the centerline in the middle of the road, the second pass will have to be set up with Sonic Control on each side of the paver. The left Tracker will match the lip of the curb and the right side Tracker will follow the new mat. The cross will not be consistent on this side of the roadway, but the joints will match.

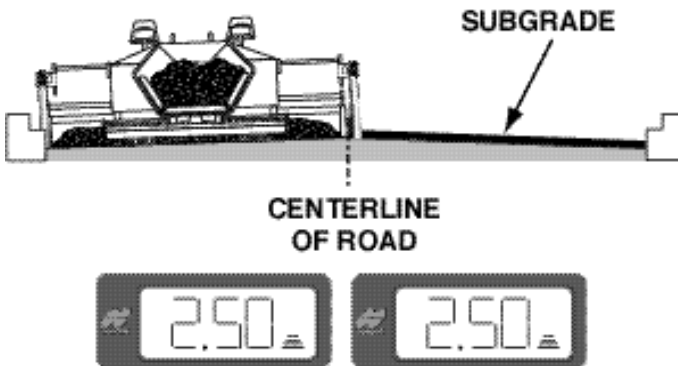

Figure 9.02e

The curb elevations can be easily spot checked using a fast leveling RL-HB rotating laser. Set the laser at the lip of one curb, then use the detector and a folding rule to take a reading on the other curb. Spot check every 25-50 feet by just moving the laser.

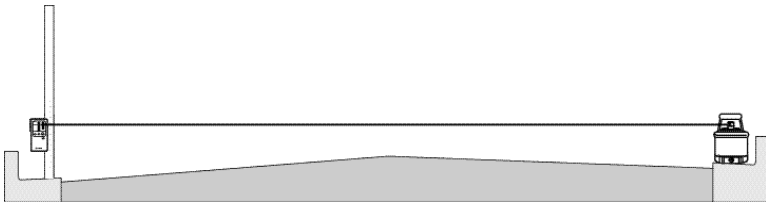

Figure 9.02f

Paving Streets Through Intersections

As you pave city streets you will come upon an intersection where the curb will not continue. There are a couple of methods for controlling grade through the intersection.

Method 1

For this method the base of intersecting road will be used as the reference.

With both sides in Elevation Control, pave to the intersection.

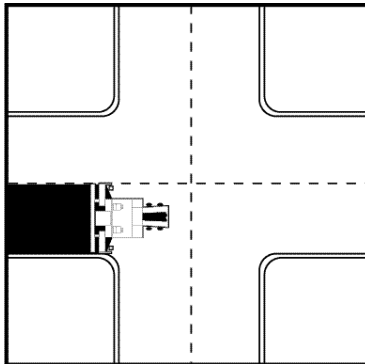

Figure 9.03a

Just before the right Tracker reaches the end of the curb, put the Control Box in Manual Mode by pushing the Red Auto Button.



Figure 9.03b

Without stopping, continue paving until the Tracker is on the base material of the intersecting road. "Survey" the Tracker On-Grade on the new reference and put back into Automatic Control.



Figure 9.03c

Pave through the intersection and just before the Tracker reaches the curb on the other side, put the Control Box in Manual mode.

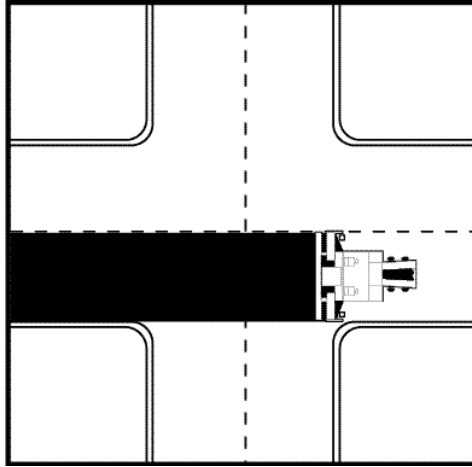

Figure 9.03d

Without stopping, continue paving until the Tracker is back on the lip of the curb. "Survey" the Tracker On-Grade and put back into Automatic Control.

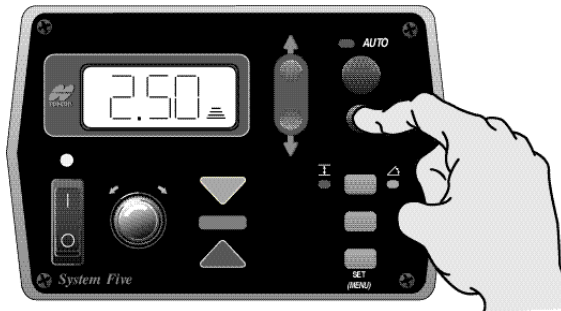

Figure 9.03e



NOTICE

You may find after surveying the Tracker on the curb that the number has changed slightly from the curb on the other side of the intersection. This is due to the different depth of the base below lip of curbs. While paving, slowly dial the display back to the previous number.

Method 2

Sometimes the base of the intersecting road is too rough to use as a reference. A great alternative is to use a simple piece of stringline. Take a section of 1/8" diameter string and nail or secure it to the curb. Pull the string tight through the intersection and nail or secure it to the other curb. If the intersecting road has a crown, hike the stringline up in the middle of the road to place the string at the proper height. A hub or a stake with a piece of wire to hold the stringline works fine.

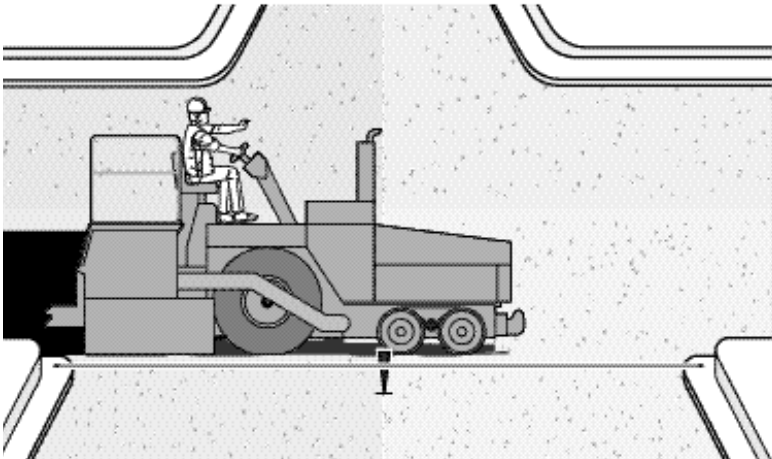

This constant reference will give you complete control through the intersection and will also insure that you tie in perfectly to both curbs.

Paving Intersections with Cross Slope

When paving with slope, intersections do not require any adjustments if the "mainline" cross slope does not change. If the slope does change, then a combination of slope and Tracker should be used.

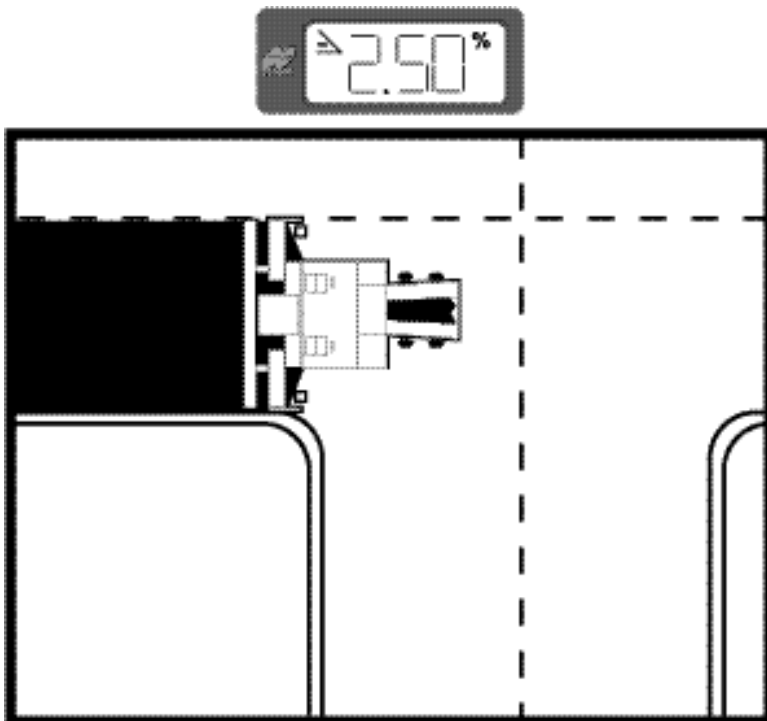

Figure 9.04a

Put the slope side of System Five Box in Manual just before the slope of the intersection begins to change. Switch from slope to elevation control on the box and "survey" the Tracker On-Grade.



Figure 9.04b



Figure 9.04c

Pave through the intersection with the Sonic Tracker in Automatic. Upon reaching the end of the intersection put the System Five Box back in Manual and change to slope control and survey the slope to get an On-grade signal.

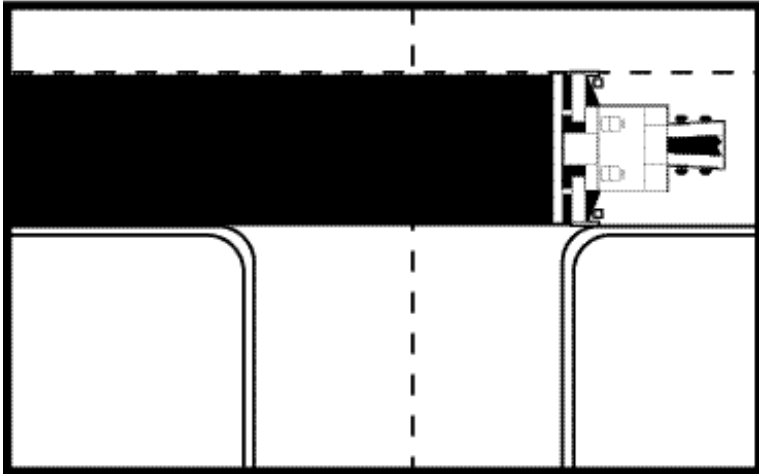

Figure 9.04d

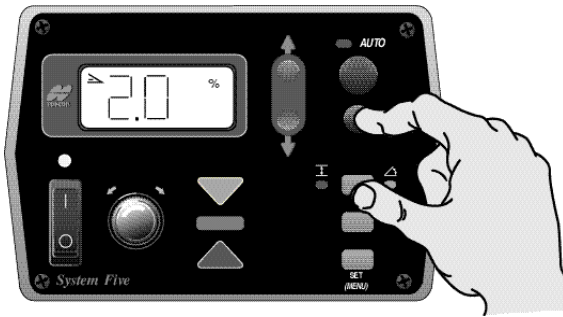

Figure 9.04e



Figure 9.04f

NOTICE NOTICE

You may find after surveying the slope that the number displayed is not the same as the desired cross slope. This will occur if the surface being paved is not also at the desired slope. To get back to the correct slope continue paving in automatic and slowly dial the display to the desired slope. Failing to survey when changing back to slope control could result in a bump in the mat.

Maintenance

This section contains information regarding preventative maintenance and daily care of System Five™. Also included are:

1. Cleaning procedures for the Sonic Tracker II™ Transducer.
2. Replacement procedures for the Sonic Tracker II™ Transducer.

Preventative Maintenance & Daily Care

A good preventative maintenance and daily care routine will prevent many problems before they occur. The most important part of daily care for System Five™ is to clean it and keep it free of debris, and to thoroughly dry removable components (Sonic Tracker II™, the Control Box, and cables) before storing them in the Carrying Case. In addition, the following procedures will ensure trouble free operation:

1. Keep the Carrying Case clean and dry. Do not leave it open and exposed to the elements. Clean and dry **all** components prior to placing them into the Carrying Case.
2. Be sure cables left on the paver are attached to protective connector caps, not in use. Water accumulating on the connectors can cause electrical shorts.

3. Do not use high pressure spray water steam cleaner hoses directly on cables and components. The components can be used in the rain or light spraying.
4. Check the Sonic Tracker II™ Transducer daily to make sure the Filter Foam and Transducer are clean and free of debris. If the Filter Foam is clogged with dirt, replace it. If the Transducer appears to be covered with debris and performance is being affected (see Sonic Tracker II™ in Chapter 2: Operation) clean or replace Sonic Tracker II™ Transducer using the steps listed later in this chapter.

Transducer Cleaning (Sonic Tracker II)



NOTICE

This procedure is not meant to be a regular maintenance procedure. Cleaning of the Transducer should only be performed when Transducer contamination is suspected or evident.

Over cleaning of the transducer will result in shortened Transducer life and/or water damage to the Sonic Tracker.

1. Hold the Sonic Tracker II™ in an UPRIGHT position (this will prevent moisture from inadvertently entering the Sonic Tracker).
2. Mix a mild detergent with water and place the mixture in a spray bottle (use Simple Green® where available.)
3. With the Sonic Tracker II™ upright, thoroughly spray the Transducer with the detergent solution.
4. Once the Transducer has been sprayed with the detergent, fill the spray bottle with clean water and rinse any residual detergent off of the Transducer.
5. Allow to thoroughly dry.

If the ability of the Sonic Tracker II™ to "see" a sonic stringline continues to be impaired, the transducer may be damaged and needs replaced.

Transducer Replacement Procedure (Sonic Tracker II)

NOTICE NOTICE

If the Sonic Tracker II is experiencing erratic or inconsistent readings, Transducer contamination should be considered first before assuming any other type of failure.

The most common sign of Transducer contamination is the ability of the Sonic Tracker II™ to “see” the ground, but not a Sonic Stringline.

Sonic Tracker II Transducer Replacement

1. Remove and discard the Filter Foam (a new Filter Foam is provided in the Transducer Replacement Kit).

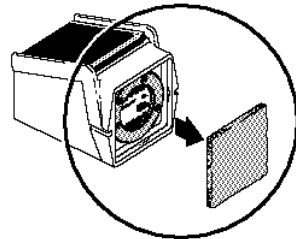
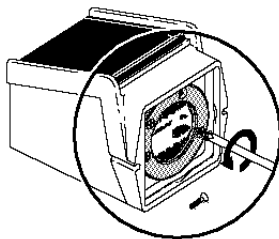

Figure 10.01a

2. Remove the four screws and the black Retaining Ring. There are four replacement screws supplied in the Transducer Replacement Kit, but it is advisable to use the original screws and keep the four supplied in the kit for replacements in the event one or more are lost.



Remove and discard the “O”-Ring (a new “O”-Ring is supplied with the Transducer Replacement kit).

Figure 10.01b

NOTICE NOTICE

Always remove and discard used "O"-Rings. Used "O"-Rings will be distorted and may lose their elasticity due to weather or exposure to diesel fumes.

3. The Transducer can now be gently pulled out. Use a SMALL pair of dikes to gently cut the Ty-Wrap then remove the small wire connectors from their tabs.

NOTICE NOTICE

When cutting the Ty-Wrap, be careful not to cut or damage the wires.

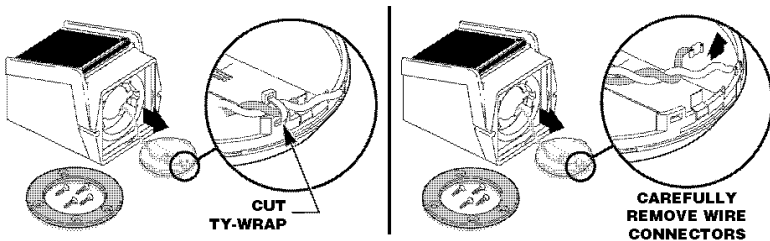

Figure 10.01c

4. Place the wire connectors of the new Transducer firmly on their tabs (the gray wire connector is placed on the elevated tab). Place the Ty-Wrap in the slot next to the elevated (gray wire) tab, tighten and trim. **DO NOT** pinch the wires.

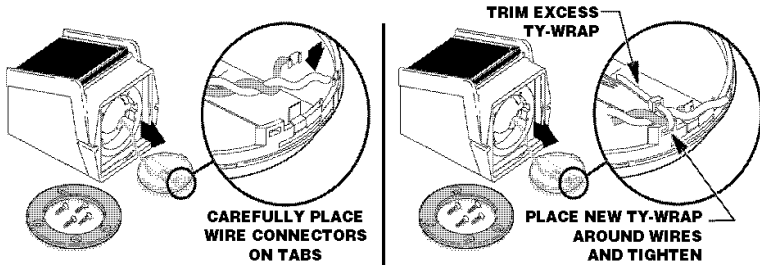

Figure 10.01d

5. "Feed" the wires back up into the Sonic Tracker II™ and seat the Transducer into place (the two wire tabs have to sit down into the extra deep area of the recess). Place the new "O"-ring around the Transducer and seat firmly between the Transducer and the Sonic Tracker II™ Transducer recess.

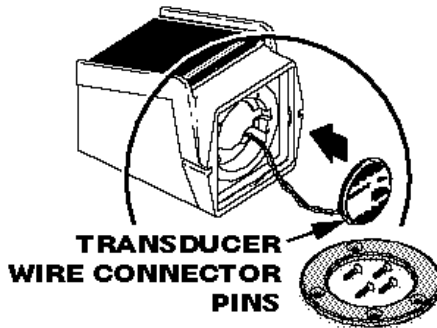

Figure 10.01e

6. Place the black Retaining Ring over the Transducer assembly with the beveled edges out and the flat surface against the Sonic Tracker II™ base. Line up the holes for the mounting screws (the mounting screw holes are set to an irregular pattern. This ensures the retaining ring will only lineup with the mounting holes one way).
7. Start the mounting screws into the holes and tighten each until firm. **DO NOT OVER TIGHTEN.** Use a cross (X) pattern to tighten screws.

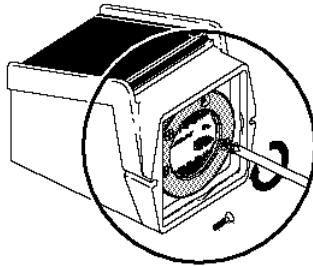

Figure 10.01f



NOTICE

Over tightening may distort the Transducer metallic material and may crack the Retaining Ring. Use of the "O"-Ring assures tightness while preventing vibration from loosening the Mounting Screws.



NOTICE

DO NOT use Loctite® on the mounting screws. Loctite® will attack the plastic retaining ring.

8. Make sure there are no visible wrinkles in the metallic surface inside the Transducer. If distortion is evident, repeat Steps 5 through 8.
9. Place a NEW Filter Foam over the Transducer. The Sonic Tracker II™ is now ready to return to operation.

Troubleshooting

Control Box Symptoms

- | |
|---|
| 1. Control Box LCD does not Display |
| 2. Control Box LCD displays "Error" |
| 3. Cannot adjust to On-Grade when Elevation Control is selected. |
| 4. Tow point cylinder does not move Up or Down |
| 5. Tow point cylinder moves in the wrong direction |
| 6. Tow point cylinder moves too fast or too slow. |
| 7. System intermittently drives the cylinder all the way up or down when tracking a mechanical ski. |
| 8. Control Box displays Error and a number from 1 to 4 |
| 9. Grade lights flash high and low and will not stay On-Grade. |
| 10. The valve is driving the hydraulic cylinder too far overshooting grade. |
| 11. The valve will not drive hydraulic cylinder far enough to get sensor On-Grade. |
| 12. The Control Box displays "No Signal" when indicate is selected in elevation mode. |
| 13. The Auto light on the Control Box intermittently flashes on and off. |

Control Box Symptom 1

- ***"The Control Box LCD does not display."***

Probable Cause

- ***No power to the Control Box.***
 1. Check that the machine power is on and all switches for automatic control on the paver are in the proper position.
 2. Check that all cables are properly and securely connected to the System Five™ Box and the paver. Make sure cables are not still connected to Control Box bracket.
 3. Disconnect cables and inspect them for damage or contamination. Clean all connections with an electrical contact cleaner.



NOTICE

Do not use electrical contact cleaner to clean the Tracker's transducer.

4. Swap Control Boxes from left to right side.
5. For System Four™ bypass Junction Box by plugging coil cord from paver to J-Box directly into Control Box.

Control Box Symptom 2

- **"Control Box LCD shows 'Error'"**



Figure 11.0

Probable Cause

- ***No communication with the sensor selected.***
1. Check that all cables are properly connected to System Five™ Control Box and sensors.
 2. Disconnect cables and inspect them for damage or contamination. Clean all connections with an electrical contact cleaner.



NOTICE

Do not use electrical contact cleaner to clean the Tracker's Transducer.

3. If elevation has been selected, one at a time, swap the Sonic Tracker II™ and cables from the opposite side to locate the error.

4. Refer to Tracker Symptom #1.
5. If slope has been selected, check that slope has not been selected on the other Control Box. Only one box at a time can have slope turned on.
6. Swap slope cable from opposite side.
7. Disconnect cable at slope sensor and connect to other side of sensor to check slope sensor pins.

Control Box Symptom 3

- *"Cannot adjust to On-Grade when elevation control is selected."*

Probable Cause

- *Tracker is too close to control reference.*
1. Check that the Sonic Tracker II™ is at least 14 inches away from the control reference.
 2. Check for unwanted objects within the sonic footprint.
 3. Make sure tracker is not positioned in front of a gusty heat source, such as the engine fan exhaust.
 4. Stop the paver, make sure the screed is on the ground and turn the vibrators off. Press Survey and hold for 2 seconds. "IND" will display on the faceplate and a number will be displayed on the LCD. The number should stay constant, or change up and down by a few numbers. If the numbers fluctuate significantly then the Transducer is probably weak or damaged.

5. Check for contamination on the Sonic Tracker II™ Transducer or foam filter. *Refer to Transducer and Filter Cleaning and replacement information in the Maintenance and Parts section of this manual.*
6. Swap the Tracker with the unit on the opposite side.
7. Averaging may be set too low if tracking an uneven reference. Factory setting is 50.

Control Box Symptom 4

- ***"The tow point cylinder doesn't move up or down."***

Probable Cause

- ***Machine electrical switches are not in the proper position, or hydraulics to the cylinder are not active.***
1. Check that all locking pins have been removed and that all hydraulic blocking valves are in the open and correct position for automatic control. Refer to the paver manufacturer's manual.
 2. Check that all machine electrical switches - and in motion circuits are in the correct position for automatic control. Refer to the paver manufacturers manual. Press the jog switch up and down on the Control Box to make sure there is a current going to the valve. Cylinder should move in the same direction the jog switch is pressed.
 3. Check that the Auto Switch is in "Auto" and that the Auto Symbol is illuminated on the front panel.

4. Disconnect cables and inspect them for damage or contamination. Clean all connections with an electrical contact cleaner.
5. Swap the Control Box with the unit on the opposite side.
6. If a Control Box is replaced make sure the configuration and performance settings are correct.
7. If a cable is replaced make sure it is the right part number. A cable with the incorrect resistor could set the Control Box to have the wrong configuration.

Control Box Symptom 5

- ***"The tow point cylinder is moving in the wrong direction."***

Probable Cause

- ***Machine is incorrectly wired or hydraulically connected.***
1. Check that the machine is properly wired and hydraulically connected to the valve. A raised jog switch should make the cylinder go up, lowering the jog switch should make the cylinder go down.
 2. Check that the proper cables have been supplied for your machine.
 3. For System Four, if "OIN" setting is in the performance menu, make sure it is in the off position.
 4. Make sure the screed lift cylinders are in the float position and not supporting the screed.

Control Box Symptom 6

- ***"The tow point cylinder is moving 'too fast' or 'too slow.'"***

Probable Cause

- ***The paving machine's hydraulic flow adjustment is incorrect, or the control box Valve Offsets or Gain Adjustments are not correct.***
1. Refer to paver manufacturers recommended flow adjustment setting for the time it takes the hydraulic cylinder to complete a full stroke of travel. Typically between 12 to 15 seconds.
 2. Adjust Gain Performance Settings. Factory setting is 25.
 3. Adjust Valve Offsets. *Refer to Valve Offset section in the Performance Section within this Manual.*

Control Box Symptom 7

- ***"System intermittently drives the cylinder all the way up or down when tracking a mechanical ski."***

Probable Cause

- ***Tracker is intermittently picking up signals from the ski.***
1. Verify string is at least 4 inches above the surface of the ski. Ski will pull away from the paver and can get in Tracker's Working Window if string is too close. Ski will also tilt to one side when traveling through a super elevation or slope transition.

2. For a multi-foot ski, make sure "foot spring pin" is not within the sonic footprint as the ski surges back and forth.

Control Box Symptom 8

- ***"Control Box displays Error and a number from 1-4"***

Probable Cause

- ***Defective Sonic Tracker or SAS cable.***
1. Check SAS cable connections at each tracker.
 2. Turn Control Box off and swap tracker showing the error number (1-4) with another tracker on the SAS. (Tracker number is on the cable at the tracker connector). Turn Control Box on to reset SAS. If the error number (1-4) has changed, the problem is the tracker. If the error number remains the same, the problem is the SAS cable.
 3. If more than one error number is shown, check trackers individually by plugging sonic trackers directly into the single tracker coil cord to determine if trackers or SAS cable is source of error.
 4. The defective tracker or SAS cable should be repaired, but SAS can still be operated without all four. Remember balance point will change if a tracker is removed.

Control Box Symptom 9

- ***"Grade lights flash high and low and will not stay on grade."***

Probable Cause

- ***If problem is only in automatic mode, then hydraulic Performance Settings are incorrect.***
 1. Verify paving machines hydraulic flow adjustments (time for hydraulic cylinder to travel full stroke) are set to manufactures recommendations.
 2. Check that the Valve Offsets are set correctly.
 3. Check that the Gain setting is too high. Factory setting is 25.
- ***If problem is in manual mode, then***
 1. Verify that temperature bails are clean and securely attached.
 2. Verify temperature bail symbol "T" is displayed on face of Tracker. If not clean or replace transducer.
 3. Check that Trackers are between 14 and 24 inches from reference.
 4. If there are gusty winds, lower Tracker closer to reference. Approximately 14 to 16 inches.
 5. Move Tracker away from gusty heat source, such as engine fan exhaust.
 6. Verify Tracker is not picking up erroneous signals from undesired reference.

Example: Head of material, end gate, shoulder grade or material spillage from hopper.

7. If using Stringline, verify line is not bouncing.
8. Check to see if Averaging in Performance Menu is set too low. Factory setting is 50.
9. Check Deadband in Performance Menu is not less than 3mm.

Control Box Symptom 10

- *"The valve is driving the hydraulic cylinder too far, overshooting grade."*

Probable Cause

- *Valve Offset in Control Box are set too high.*
1. Lower the Valve Offset value till the sensor no longer overshoots grade. *Refer to "Setting Valve Offsets" section in this manual.*
 2. For Servo and solenoid valves lower the value by 2 to 5 numbers, then check the hydraulic performance.
 3. For Proportional valves, lower the value by 10 to 15 numbers, then check hydraulic performances.

Control Box Symptom 11

- *"The valve will not drive hydraulic cylinder far enough to get sensor On-Grade."*

Probable Cause

- *Valve offsets in Control Box are set too low.*
1. Raise the Valve Offset Value till the sensor is driven to grade. *Refer to "Setting Valve Offsets" section in this Manual.*

2. For Servo and Solenoid valves raise the value by 2 to 5 numbers, then check hydraulic performance.
3. For Proportional valves raise the value by 10 to 15 numbers, then check hydraulic performance.

Control Box Symptom 12

- ***"The Control Box displays 'No Signal' when indicate is selected in elevation mode."***

Probable Cause

- ***Sonic Tracker is reporting no echo.***
1. Verify that the Sonic Tracker is ticking.
 2. Make sure tracker is pointing at a target with the working range, recommended 14 to 24 inches.
 3. Transducer may be dirty or damaged. *Refer to the Transducer and Filter section within this manual.*
 4. Power or ground connection at transducer may be loose. Remove transducer and check wires.

Control Box Symptom 13

- ***"The Auto light on the Control Box intermittently flashes on and off."***

Probable Cause

- ***Sonic Tracker is too far from reference for current atmospheric conditions, or Temperature Cutout is too low.***
1. Verify that the Sonic Tracker is positioned 14 to 24 inches from the reference. If there are gusty winds lower the Tracker to 14 to 16 inches from the reference.
 2. Move Tracker away from gusty heat source, such as engine fan exhaust.
 3. Temperature Cutout is set too low. Factory setting is 7. Refer to Technicians manual.

Tracker Symptoms

- | | |
|----|---|
| 1. | Sonic Tracker will not power on. |
| 2. | Sonic Tracker is ticking, but will not adjust to Grade |
| 3. | Tracker grade lights flash high and low and will not stay On-Grade. |
| 4. | Sonic Tracker is not matching joint or curb. |
| 5. | The Sonic Tracker will pick up the ground, but will not pick up a stringline. |

Tracker Symptom 1

- ***"Sonic Tracker will not power on"***

Probable Cause

- ***Defective cable or tracker.***
 1. Check coil cord is plugged in correctly and securely.
 2. Inspect Coil cord for any physical damage.
 3. Turn Control Box on and watch the tracker lights to make sure they go through the power up sequence. All the lights on the tracker should flash at once followed by a flash of an arrow pointing to the left. The "T" symbol should also be displayed in the upper right hand corner of the tracker faceplate when a Temperature Bail is attached. If the tracker does not go through this sequence then the tracker is not getting power or is defective.
 4. One at a time, swap tracker and then coil cord from opposite side to determine the problem.

Tracker Symptom 2

- ***"Sonic Tracker is ticking, but will not adjust to grade."***

Probable Cause

- ***Tracker is too close to reference, minimum working distance is 14 inches.***
1. Tracker is too close to reference point. Position tracker 14 to 24 inches from grade reference.
 2. Connect tracker to other side of paver to determine if problem stays with tracker.
 3. If problem stays with tracker, clean or replace transducer or foam filter. *Refer to the Transducer and filter cleaning and replacement information in the "Maintenance and Parts" section of this manual.*
 4. If problem does not move with tracker, inspect coil cord for damage and swap with cord from other side.

Tracker Symptom 3

- ***"Tracker grade lights flash high and low and will not stay On-Grade."***

Probable Cause

- ***If problem is only in Automatic Mode, then Hydraulic Performance Settings are incorrect.***
1. Verify paving machines hydraulic flow adjustments, time for hydraulic cylinder to travel full stroke, are set to manufacturers recommendations. Typically 12 to 15 seconds.

2. Check Valve Offsets are set correctly. Refer to setting valve offsets.
3. Make sure Gain Setting is not too high. Factory setting is 25.
 - *If problem exists in manual mode, then Tracker is setup incorrectly or Performance Settings are incorrect.*
1. Verify that temperature bails are clean and securely attached.
2. Verify temperature bail symbol "T" is displayed on face of Tracker. If not, clean or replace transducer.
3. Check that Trackers are between 14 and 24 inches from reference.
4. If there are gusty winds, lower Tracker closer to reference. Approximately 14 to 16 inches.
5. Move Tracker away from gusty heat source, such as engine fan exhaust.
6. Verify Tracker is not picking up erroneous signals from undesired reference.

Example: Head of material, end gate, shoulder grade or material spillage from hopper.
7. If using Stringline, verify line is not bouncing.
8. Check to see if Averaging in Performance Menu is set too low. Factory setting is 50.

9. Check that Deadband, in Performance Menu, is not less than 3mm.

Tracker Symptom 4

- *"The Sonic Tracker is not matching joint or curb."*

Probable Cause

- *Tracker is too far forward on the tow arm.*
1. Position the Tracker at 1/3rd the tow arm length (just in front of auger).
 2. Gain for tracker may be set too low. Adjust Gain to a minimum of 25.
 3. Brackets and L-Bars have not been securely tightened. Also, check for excessive play or slop where tracker is attached to the paver. (Tow arm or end gate.)

Tracker Symptom 5

- *"The Sonic Tracker will pick up the ground, but will not pick up a stringline."*

Probable Cause

- *Tracker is too close to a reference or transducer is weak.*
1. Verify that tracker is at least 14" from the stringline.
 2. Smooth, steel wire is not recommended. Use minimum 1/16" diameter string for elevated stringline or averaging ski. Use 1/8" string for Surface Stringline.

Slope Sensor Symptoms

1. Cross Slope reads "Error"
2. Cross slope drives cylinder in the wrong direction
3. Slope lights flash between raise and lower and will not stay On-Grade.
4. Cross slope will not lock On-Grade.
5. Cross slope being laid is not correct.

Slope Sensor Symptom 1

- *"Cross Slope reads 'Error.'"*

Probable Cause

- *Both Control Boxes are selected for slope or have a defective cable.*
1. Cross slope operates one side at a time. Verify only one Control Box has been selected for slope.
 2. Verify that the slope cable is connected securely and properly.
 3. Swap slope cable from other side to check cable.

Slope Sensor Symptom 2

- ***"Cross Slope drives cylinder in the wrong direction."***

Probable Cause

- ***Slope sensor installed incorrectly.***
1. Verify the slope sensor is positioned correctly on the transverse beam. "Slope Forward" Decal must be in direction of travel.
 2. Check that the machine is properly wired and hydraulically connected to the valve. Raised jog switch should make the cylinder go up, lower jog switch should make the cylinder go down. Refer to the paver manufacturers manual.

Slope Sensor Symptom 3

- ***"Slope lights flash between raise and lower and will not stay On-Grade."***

Probable Cause

- ***Incorrect Performance Setting adjustments or a loose transverse beam.***
1. Check Valve Offset for proper operation. Refer to "Setting Valve Offsets" section in this manual.
 2. Check gain setting. Factory setting is 25.
 3. Slope deadband set too low. Increase Slope Deadband. Factory Setting is .075%
 4. Check for excess vibration in the Transverse Beam due to poor connection at Tow Arm.
 5. Make sure slope sensor is mounted directly to the Transverse Beam and is not elevated or supported by additional brackets.

Slope Sensor Symptom 4

- ***"Cross Slope will not lock On-Grade."***

Probable Cause

- ***Loose Transverse Beam or incorrect Performance Setting adjustments.***
 1. Verify that the Slope Sensor is not moving or vibrating when trying to survey slope on grade.
 2. Slope deadband setting is too low, factory setting is .075%.
 3. Stop the paver, make sure the screed is on the ground and turn the vibrators off. Press Survey and hold for 2 seconds. IND will display on the faceplate and a slope value will appear in the LCD. The number should stay constant or change up or down by a few counts. If the numbers fluctuate significantly then the slope sensor is probably the problem.

Slope Sensor Symptom 5

- ***"The Cross Slope being laid is not correct."***

Probable Cause

- ***Calibration in Slope Sensor is incorrect.***
 1. Calibrate the Slope Sensor as described in *"Daily Cross Slope Calibration"* in the *Function and Operations* section.
 2. Check that the Transverse Beam is mounted according to the manufacturer's instructions and that it is not loose or damaged.

3. Recheck slope using a good reference such as a laser or level. Make sure to wait at least 3 tow arm lengths before checking the slope after a change has been made.
4. If the paver's mat thickness controls have been used then the slope calibration may have to be changed. This can occur after "buying back" cylinder.

SAS Symptoms

- | |
|--|
| 1. When the SAS is connected, control Box displays "Error" and a number. |
| 2. 1 Tracker stops working |
| 3. SAS will not lock On-Grade |
| 4. SAS is not producing smooth surface |
| 5. Tracker picking up head of material |

SAS Symptom 1

- *"When the SAS is connected, the Control Box displays 'Error' and a number."*

Probable Cause

- *Defective tracker or cable, tracker with incorrect code.*
 1. Verify that all trackers are correctly and securely plugged into the SAS cable.
 2. Turn Control Box off and move the Tracker to a different position on the SAS cable. Turn the Control Box on to reconfigure SAS. If error number moved positions with the swapped tracker, then the tracker is the problem. Replace transducer if necessary. *Refer to transducer and filter cleaning and replacement information in the "Maintenance and Parts" section of this manual.*

3. Check to see if a Tracker without SAS code is attached to the cable. Verify that the tracker has a SAS compatible decal near the S/N label.

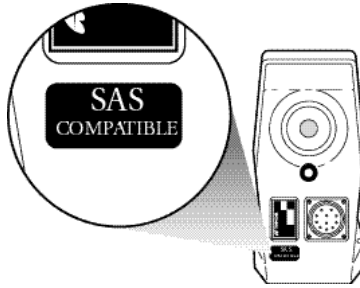

Figure 11.01a

4. Tracker can also be checked by verifying code revision. Turn box off and back on. Watch the temperature bail symbol in the top right portion of the tracker. The "T" symbol will flash a certain number of times, pause and flash again to indicate the revision of its code.

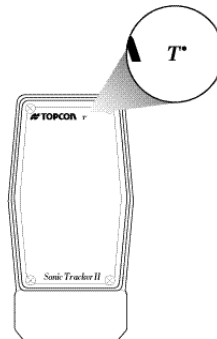

Figure 11.01b

Example: Flash twice, pause flash twice means the code in the Tracker is 2.2. SAS requires trackers with code of 2.2 or higher.

SAS Symptom 2

- *"A Tracker stops working."*

Probable Cause

- ***Defective Tracker.***
 1. Check SAS cable connections at each tracker.
 2. Turn off Control Box and swap tracker showing error with another tracker on the SAS. (Tracker number is on the cable at the tracker connector). Turn the Control Box back on to reset SAS. If error number moved positions with the swapped tracker, then the tracker is the problem. Replace transducer if necessary. *Refer to Transducer and Filter Cleaning and Replacement information in the "Maintenance and Parts" section of this manual.*
 3. If error continues to display for the same position even after trackers have been swapped, the tracker connector or SAS cable is the problem.
 4. The defective tracker or SAS cable should be repaired, but SAS can still be operated without all four trackers operating. Remember balance point will change if a tracker is removed.

SAS Symptom 3

- *"SAS will not lock on grade."*

Probable Cause

- *Tracker too close to reference or defective transducer in Tracker.*
1. Verify that all cable connections are properly and securely connected.
 2. Check that all trackers are sending out sound waves (transducer is making ticking sound) and grade lights are flashing.
 3. If tracker is not working, check that transducer and foam filter are clean and free from damage. Replace transducer if necessary. *Refer to transducer and filter cleaning and replacement information in the "Maintenance and Parts" section of this manual.*
 4. SAS beam and trackers may be too close to reference. Bottom of tracker must be minimum of 14 inches from reference.
 5. Non-SAS compatible tracker attached to cable. Verify tracker has SAS compatible decal near S/N label.

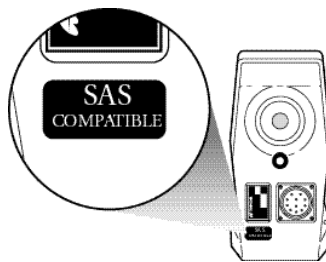

Figure 11.02

SAS Symptom 4

- *"SAS is not producing smooth surface."*

Probable Cause

- *Improper setup or Performance Menu Settings.*

1. Verify that temperature bails are clean and securely attached.
2. Verify temperature bail symbol "T" is displayed on face of Tracker. If not clean or replace transducer. *Refer to transducer and filter cleaning and replacement information in the "Maintenance and Parts" section of this manual.*
3. Check that Trackers are between 14 and 24 inches from reference.
4. If there are gusty winds, lower SAS to get Trackers closer to reference.
5. Move the Tracker away from gusty heat source, such as engine fan exhaust.
6. Verify that the Trackers are not picking up erroneous signals from undesired reference.

Example: Head of material, end gate shoulder grade or material spillage from hopper.

7. Verify that the center of the SAS beam is between the midpoint and the forward 2/3 point of the tow arm.
8. Check to see if Averaging in Performance Menu is set too low. Factory setting is 50.
9. Check that Deadband in Performance Menu is not less than 3mm.

10. Check that Valve Offsets are set properly.
11. Check that the Gain setting in the Performance Menu is not set too high. Factory setting is 25.

SAS Symptom 5

- *"Tracker picking up head of material."*

Probable Cause

- *Improper placement of Tracker*
 1. Move tracker forward of the material. Rotate Tracker to front of bracket or drill a hole in the beam far enough forward to move tracker away from material.
 2. Check balance point. Balance point will shift when moving a tracker.

A ppendix

A

Aggregate

Various hard, inert materials such as sand, gravel, pebbles, etc. used as the bulk material in asphaltic mixes.

Angle of Attack

The angle that exists between the bottom of the screed and the grade over which the screed is traveling.

Auger

The broad, spiral flange on a screed which rotates and spreads paving material evenly in front of the screed.

Auger Shadows

The dark and light areas along the length of a mat surface caused by the compaction of materials having different densities and textures.

Automatic Feed Controls

The dual feed system on a paving machine used to maintain a constant head of material in front of the screed.

Automatic Grade and Slope Controls

Sensing equipment used on paving machines to set and maintain proper elevations and percent slope. Paver Control System Five™ provides paver operators with automatic grade and slope control.

B

Bitumen

A thick, viscous, petroleum-based substance used as a bonding agent in asphaltic mixes.

Bail

A wire frame added to the Tracker that acts as a fixed target to compensate for rapid air temperature changes.

C

Calibration

Setting the elevation reading or Slope Sensor reading to match the actual position of the screed.

Compaction

To press tightly, thereby increasing the density of paving material.

Cone

Pattern of distribution of the Sonic Tracker II™ sound waves. The sound waves leave the Tracker in a circular pattern that gets wider as it gets further from the Tracker.

Conveyor

The assembly used to move paving material from the hopper to the auger.

Cross Slope

The angle of slope required to produce a desired surface slope. Cross slope is measured in percent.

Cross Slope

The angle of slope required to produce a desired surface slope. Cross slope is measured in percent.

Crown

1. The transverse contour of a finished mat.
2. The contour of the screed plate.
3. The transition line between 2 different slopes (i.e. between lanes or between lanes and shoulders).

Lead Crown

The contour or profile from side to side of the leading edge of the screed.

Tail (Road) Crown

The contour of the trailing edge of the screed.

Negative Crown

Contour which is higher at the edges than at the center of a mat.

Positive Crown

Contour which is higher at the center than at the edges of a mat.

Cut-off Shoe

A detachable plate used to reduce the paving width of a screed.

D

Density

Compactness of paving material.

E

Edger Plate

A vertical plate at each end of the screed used to con fine the head of material.

Elevation

The vertical height or depth of the surface being laid. Elevation is measured in centimeters, inches, or feet.

F

Feeders

The auger-conveyors on the right and left hand sides of a paving machine.

G

Grade

1. The base surface (road bed) over which paving is being laid.
2. The elevation of a fresh mat in relation to the base.
3. The incline of a paving surface in the direction of travel, expressed by stating the rise or fall as a percent age of horizontal distance (i.e., 6% grade = 6' of elevation change in 100' of horizontal longitudinal run).

Grade Control

A means of controlling the elevation of a mat as it is being laid.

Grade Sensor

An electric device which detects positive and negative changes in elevation from a grade reference (i.e., surface string, floating beam, mat reference, adjacent mat or curb surface).

H

Head of Material

The volume of paving material directly in front of and across the entire length of the screed.

Hopper

The area at the front of the paving machine which receives the paving material.

Hydraulic

Liquid in motion under pressure, the flow of which causes work to be accomplished.

Hydrostatic Transmission

Power transmitted by a positive displacement pump through a liquid under pressure to a positive displacement motor.

I

Inclinometer

See Slope Sensor

J

Joint Matcher

See Automatic Level Control

L

LCD

Liquid crystal display. LCD is used in the display window on the Control Box and Sonic Tracker IITM to show numbers and symbols for Paver Control System Five™ functions.

LED

Light Emitting Diode. These are the red lights seen on the faces of the Control Box, Sonic Tracker IITM and Laser Tracker.

Line of Shear

The lateral line of contact in the paving material at the leading edge of the screed pre-strike-off where material divides to pass beneath the screed plate or moves upward along the face of the screed into the augured material for later placement.

M

Mat

The material being placed by a paver/finisher

N

Null

A condition which exists when components are at rest.

"Null" Screed

A screed resting flat on the mat and having no angle of attack.

O

On Grade

When a surface is at the desired elevation or slope, it is referred to as being on grade.

Overlay

Paving over an existing mat.

P

Paddle Box

The sensing device used with automatic feed control to measure and control the head of material.

Percent (%) Slope

The unit of measure used for cross slope.

Pull Points

See Tow Points

Push Roller

Rollers mounted at the front of the paver to control the contact area between the paver and the asphalt truck tires.

Q

Quarter Points

Points on the screed midway between the center and the ends.

R

Ripples

Short frequent changes in the elevation of a mat surface.

S

Screed

The assembly behind the tractor. The screed strikes off, smooths and compacts the paving material into a semi-finished mat.

Screed Extensions

Attachments for increasing screed width

Screed Heaters (Burners)

Devices which preheat the screed plate to a temperature approximately that of the material to be laid.

Screed Plate

The bottom plate of the screed

Slope

The incline of a paving surface perpendicular to the direction of travel expressed by stating the rise or fall of a percentage of horizontal distance (i.e. 2% slope = 2" of elevation change in 100" of lateral run).

Slope Control

A means for controlling the transverse elevation of the fresh laid mat in relation to the grade.

Slope

The incline of a paving surface perpendicular to the direction of travel expressed by stating the rise or fall of a percentage of horizontal distance (i.e. 2% slope = 2" of elevation change in 100" of lateral run).

Slope Control

A means for controlling the transverse elevation of the fresh laid mat in relation to the grade.

Q

Slope Sensor

An electrical device which detects positive and negative change in lateral elevation using the grade controlled side of the machine as a reference.

Survey

Function used to show the current elevation when in CAL mode. Also used in Laser Tracker operations in conjunction with the Enter Button to move the Tracker receiver up and down.

T

Thickness Control Screws

The adjusting crank located at the rear of each side arm, used to control the angle of attack of the screed.

Tow Points (Pull Points)

The points where the side arms of the screed are attached to the Tractor unit.

Transverse Beam

A steel bar connected to the side arms of a screed for mounting the Slope Sensor.

Temperature Bail™

A wire frame added to the Tracker that acts as a fixed target to compensate for rapid air temperature changes..

V

Vibrators

A rotating shaft and eccentric weight assembly mounted on the screed that produces vibration.

W

Wave

Long repeating changes in the elevation of the mat surface.

Working Window

Adjustable region of measurement used by the Sonic Tracker II™ to determine if elevation correction is required.



Topcon Positioning Systems, Inc.

5758 W. Las Positas Blvd.
Pleasanton, California U.S.A.
Phone: 925 • 460 • 1300
Fax: 925 • 460 • 1315

©2002 Topcon Corporation All rights reserved
No unauthorized duplication

P/N: 7010-0341 Rev. D (2nd Print) Printed in U.S.A 3/02 500

A partial view of a device screen showing the TOPCON logo in the top right corner. The logo consists of a stylized 'T' symbol followed by the word 'TOPCON' in a bold, sans-serif font. The screen is dark, and the logo is light-colored. There is a small circular icon with a plus sign in the top left corner of the screen area.

TOPCON

Sonic T