Operation & Maintenance Manual

VERSASCREED

Operation & Maintenance Manual



TEREX

Roadbuilding

Operation & Maintenance Manual

VERSASCREED

Operation & Maintenance Manual



TEREX

Roadbuilding

To the Owner & Operator:

We have tried to provide information that gives our customers a clear understanding of equipment construction, function, capabilities and requirements. This information is based on the knowledge and experience of qualified people at our company and in our field organization. Proper use of this information rewards users of our equipment with high efficiency, maximum service life and low maintenance costs. That is why we strongly recommend that anyone using our equipment be familiar with this manual.

Information presented here should not be considered authoritative in every situation. Users will as a matter of course encounter problems and circumstances that raise questions not anticipated here. Such questions should be directed to their distributor or the factory.

Anyone who uses this equipment for any purpose other than that for which it was intended assumes sole responsibility for dangers encountered and injuries sustained as a result of such misuse.

⚠ DANGER

Federal, state and local safety regulations aim to protect both people and property from accident, injury and harmful exposure. When complied with, such regulations are often effective. Hazards to personnel and property are further reduced when this equipment is used in accordance with all operation and maintenance instructions. Generally:

- (1) Read and heed all danger, warning, caution, and notice decals. Know what guards and protective devices are included and see that each is installed and in operational condition. Additional guards and protective devices may be required and must be installed by the user (owner) before operating.
- (2) Never attempt to maintain, lubricate or adjust this equipment while it is running. Lock out and tag out all energy sources before doing maintenance, cleaning, adjusting or repairing this equipment. Make it impossible for anyone to start this machine while others are working on it or in it.
- (3) Wear personal protective equipment such as hard hats, ear plugs, safety glasses and safety shoes when operating this equipment. Do not wear loose clothing or long hair.
- (4) Think safety and act safely. Stay alert at all times. Eliminate or neutralize potential hazards as soon as you spot them. Never allow anyone to engage in horseplay when near this equipment.

⚠ DANGER

Failure to take these precautions will result in death or severe personal injury.



TEREX
Roadbuilding

The following warning applies to equipment supplied with lead-acid batteries:

⚠WARNING

Battery posts, terminals and related accessories contain lead and lead compounds, chemicals known to the State of California to cause cancer and reproductive harm.

Wash hands after handling.



TEREX

Roadbuilding

This Page Intentionally Left Blank



Table of Contents

Terex Cedarapids Paver Manuals 1

 Operation and Maintenance Manual 1

 Technical Manual 1

 Quality Paving Guide 1

 Wear Check Guide 1

 About the Pocket Paver Guide 1

 CIMA Safety Manual 1

Hazard Levels 1

Identification Number Location 3

 Tractor 3

 Screed 4

Lockout Tagout 5

 What is the purpose of lockout /tagout? 5

 How do I lockout and tagout equipment? 5

 Who is responsible for establishing and administering a lockout /tagout program? .. 5

 When is lockout and tagout necessary? 5

 Who should apply a lock or tag? 5

 When can a lock or tag be removed? 5

 Who can remove a lock or tag? 5

General safety 6

 Danger 6

 Warning 6

 Caution 7

Decals and Icons 7

Safety Decal Location 8

Receiving New Equipment 9

Principle Of Operation 10

Equipment Description 11

Electrical System Operation 13

 Control Panel Functions 14

 Temperature Controllers 15

 Section Controllers 15

 All-In-One Meter 16

 Circuit Breakers 16

 Screed Heater Operation 16



Table of Contents

Remote Control 17

 Raising and Lowering Screed 17

 Supporting an elevated screed 17

Detaching & Attaching Screed 18

Operating the Screed 19

 Mat Thickness Control 19

 Screed Pull Arms 20

 Tow Point Cylinder Speed Test 20

 Tow Point Position 21

 Effects of Tow Points Positioned Too High 21

 Effects of Pull Points Positioned Too Low 22

 Correct Tow Point Position 22

Screed Adjustments 23

 General 23

 Position Tow Points 23

 Nulling the Screed 23

 Mat Crown Control 23

 Lead/Trail Crown 24

 Final Crown Adjustment 25

 Screed Bottom Flatness 25

 Match Height Adjustment 26

 Independent Angle of Attack 26

 Independent Angle of Attack Adjustment 27

 Extending Screed Alignment 28

Screed Accessories 29

 Heaters 29

 Screed Vibrators 29

 Operating Screed Vibrator 29

 Vibrator Weight Installation and Alignment 30

 Strike-Offs 31

 Adjusting Strike-off 31

 Changing Screed Bottom 32

 Screed Bottom Removal 32

 Screed Bottom Installation 33



Table of Contents

Cleaning the Screed34

Lubrication35

 General 35

 Depth Cranks 35

 Vibrator Bearings 35

 Match Height 35

 Extending Screed Slope 35

 Crown 35

Tractor Generator Pump Plumbing36

 Attaching Screed to Tractor 36

 Operating Pump Without Screed 36

VersaScreed 8 Generator Pump Setup37

 Start-up After Initial Installation of Pump 37

 Set Pump Max Pressure 38

 Set Pump Standby Pressure 38

VersaScreed 10 Generator Pump Setup39

 Start-up After Initial Installation of Pump 39

 Set Pump Max Pressure 40

 Set Pump Standby Pressure 40

Set Generator Motor Speed (Frequency)41



Table of Contents

This Page Intentionally Left Blank



Terex Cedarapids Paver Manuals

Terex Cedarapids Paver Manuals

The following list represents the complete set of manuals available to the owner, operator, and mechanic of a paver. All of these manuals are included with each new paver when it ships from the factory. If your manuals are not included with your new paver or if you require additional copies of any of these manuals contact your local Terex Cedarapids dealer.

Operation and Maintenance Manual

The Operation and Maintenance manual is intended to be used by both the operator and mechanic.

The operation portion of this manual gives detailed operating and safety instructions for both new and experienced operators. It is intended to give more detailed information than the Pocket Paver Guide.

The maintenance portion of this manual gives detailed information on component locations, test procedures, safety, and routine maintenance. This information expands on the information in Technical manual and Wear Check Guide.

Technical Manual

The Technical manual is designed primarily for use by maintenance personnel. It provides detailed troubleshooting procedures and schematics for diagnosing paver breakdowns. Once a problem has been diagnosed, refer to the Operation and Maintenance manual for information on making the repair.

Quality Paving Guide

The Quality Paving Guide should be used primarily by paver operators. This manual gives detailed information on setting up the paver to produce the mat surface needed.

Wear Check Guide

The Wear Check Guide should be used primarily by maintenance personnel. It contains detailed information for determining when parts require replacement.

About the Pocket Paver Guide

The Pocket Paver Guide is a small reference manual designed for use by experienced operators. It contains information needed by the operator for day-to-day operation, adjustment and maintenance of the paver and screed.

CIMA Safety Manual

The CIMA Safety Manual is a general manual designed to be used by everyone on a paving job site. This would include operators, laborers, mechanics, truck drivers, etc.

Hazard Levels

The signal words **Danger**, **Warning** and **Caution** are used to identify hazard levels of in this manual. They may also be found on decals located on the equipment. (Figure 1)

Hazard Levels

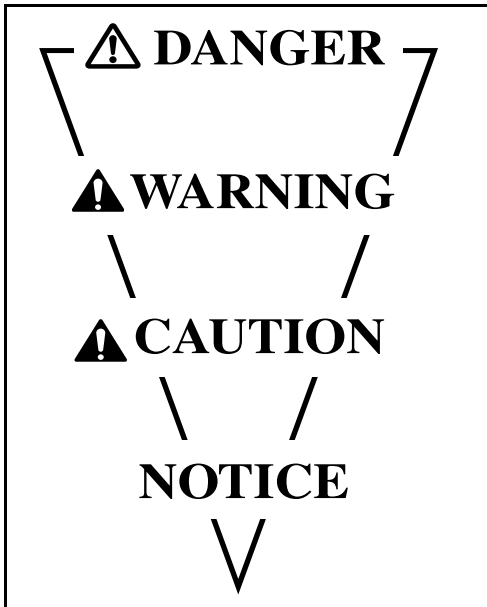

Figure 1 Hazard Level Hierarchy

Definitions for identifying hazard levels and their signal words are provided below:



Danger - Indicates an imminently hazardous situation which, if not avoided, will result in death or serious injury.



Warning - Indicates a potentially hazardous situation which, if not avoided, could result in death or serious injury.



Caution - Indicates a potentially hazardous situation which, if not avoided, may result in minor or moderated injury.

The single word **Notice** is used to indicate information or a company policy that relates directly or indirectly to the safety or protection of property.

Identification Number Location

Identification Number Location

Tractor

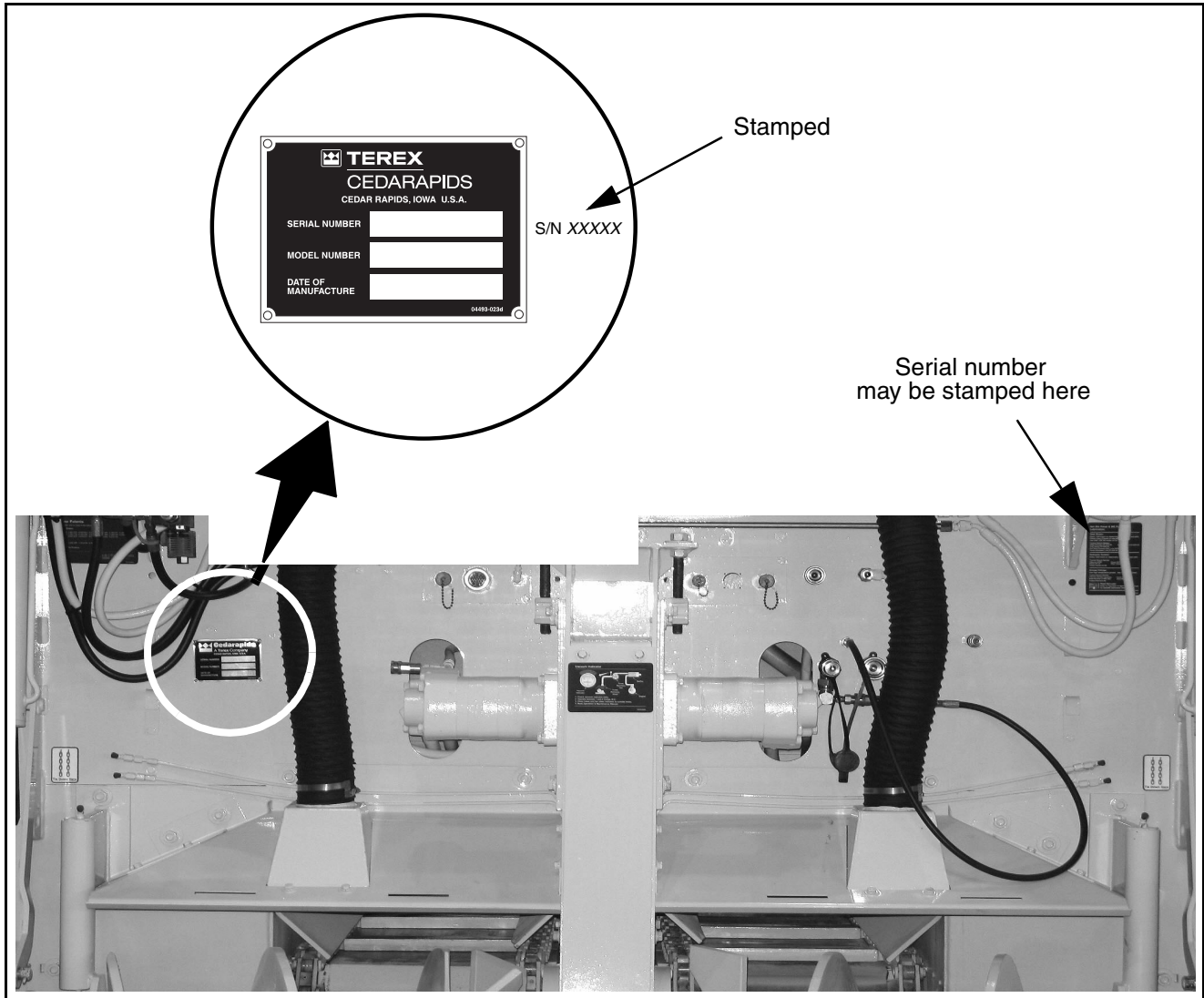

Figure 2 Tractor ID Number Locations

The serial number plate for current model tractors can be found on the left rear frame bulkhead. In addition, the serial number will be stamped into the bulkhead to the right of the serial number plate. On early model tractors, the serial number may be stamped into the bulkhead and covered with the serial number plate. (Figure 2)

The serial number will also appear on the lubrication decal found on the right rear frame bulkhead.

Identification Number Location

Screed

The VersaScreed carries both a serial number and a module number to simplify identification when ordering parts.

The identification plate bearing both numbers is located on the right-hand screed pull arm. In addition, the screed module number is stamped on the right-hand pull arm above the identification plate. (Figure 3)

If a VersaScreed is shipped as a single item (to be mounted on a paver in the field) the serial plate will be mounted below the screed identification plate on the right-hand pull arm.

Refer to the following illustration for location of the stamped module numbers and identification.

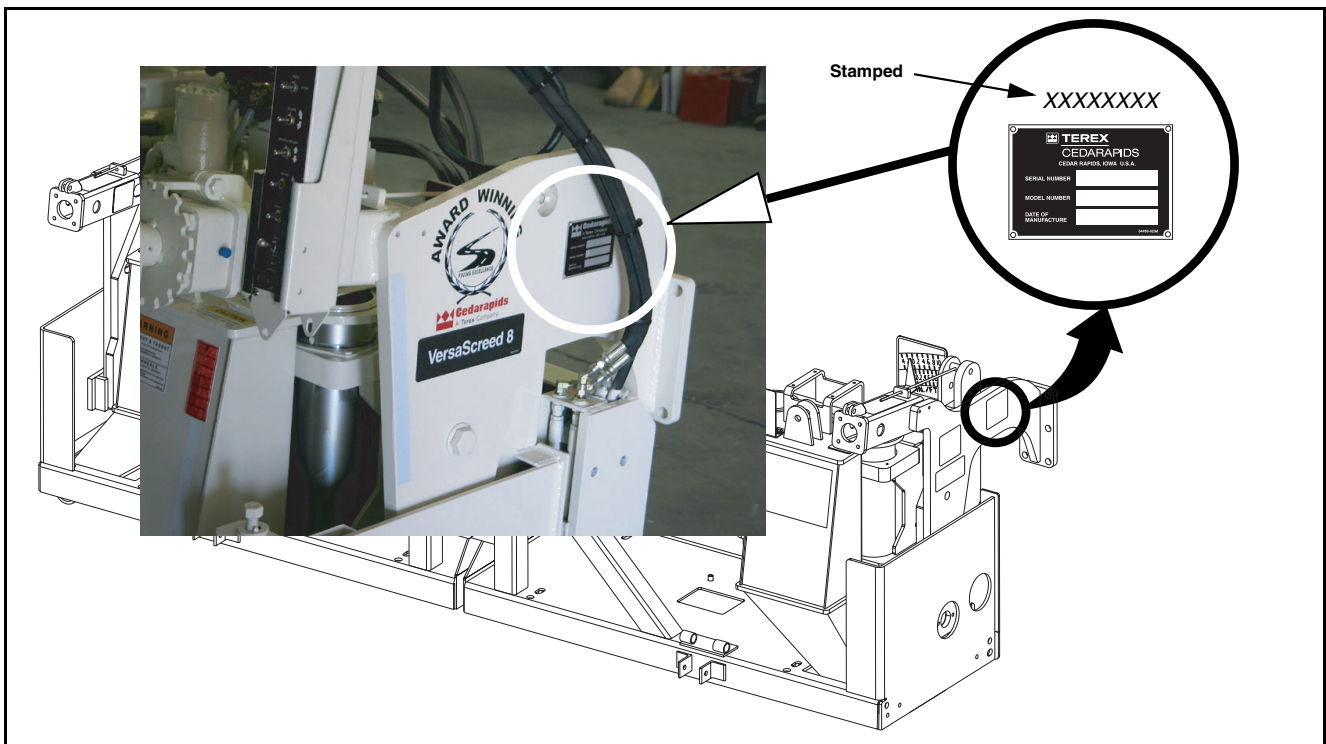

Figure 3 VersaScreed Identification Number Location

Lockout Tagout

Lockout Tagout



Warning - Failure to follow good lockout and tagout procedures could result in serious injury or death.

What is the purpose of lockout /tagout?

- Prevent the unexpected or accidental start-up of equipment and to notify other workers when a piece of equipment is unsafe to operate.
- Prevent injury to personnel from energy that is stored in devices such as springs, accumulators, hydraulic systems, batteries, etc.

How do I lockout and tagout equipment?

- Turn the master key to the OFF position and lock.
- Disconnect the batteries.
- Engage emergency stop switch and lock.
- Regardless of which lockout method is used, place one or more tags on machine controls or access doors to let other workers know that maintenance is being performed on the machine and/or the machine is unsafe to operate.

Who is responsible for establishing and administering a lockout /tagout program?

- The employer must establish a lockout /tagout system of procedures, training and periodic inspection before any employee operates, services, or maintains a piece of equipment.
- All employees are responsible for seeing that equipment is locked out and tagged out according to the employers policies.

When is lockout and tagout necessary?

- Any time repairs or maintenance on a machine are to be performed.
- When cleaning or lubricating the machine.
- While clearing blocked or jammed mechanisms.
- Any time that the equipment will be left unattended.

Who should apply a lock or tag?

- Any maintenance person who will be working on the equipment.
- The foreman or team leader responsible for the job.
- Anyone who will be working on the equipment.
- If several people will be working on a piece of equipment, each person must apply their own tag.

When can a lock or tag be removed?

- After all safety guards are back in place.
- After work is complete and tools are put away.
- After workers are positioned safely for start-up.
- After controls are positioned correctly for start-up and machine is operation ready.

Who can remove a lock or tag?

- Only the person who applied a lock or tag can remove it.

General safety**General safety**

This manual contains important information regarding the operation of the screed with your paver. Carefully read the entire manual before attempting to operate the paver. Make sure everyone working on or near this equipment is familiar with safety precautions.

Danger

- Install all auger guards and vibrator covers before operating the paver.
- Never attempt to install or remove any part or assembly when the paver is running.
- Do not allow personnel to stand or walk between the front of the paver and the back of the truck while the paver is operating.
- Engage screed locks or lower the screed before performing any inspections, repairs or adjustments to the screed.
- All guards and protective devices must be in place when the paver is being operated or moved.
- Keep all personnel clear of augers when the paver is operating.
- Do not refuel the paver with the engine or screed heater system running. All sparks and open flames must be kept a minimum of 50 feet away from the paver when refueling.
- Do not wash or spray down the screed or tractor with the screed heater system operating.

Warning

- Do not operate this equipment until you have been trained in its operation or maintenance. This equipment may only be operated or maintained by trained personnel, who have demonstrated their ability to do so safely.
- Keep this manual for future reference.
- Read, understand and follow all current OSHA, federal, state and local regulations that are applicable to your job and equipment.
- This equipment must be used in accordance with all operation and maintenance instructions.
- All persons involved with this equipment must be familiar with this manual.
- Read, understand, and follow all Danger, Warning, Caution and instruction decals in this book and on the paver.
- When changing the paver configuration or adding equipment to the paver, all additional guards associated with the added equipment must be installed before operating or moving the paver.
- Any changes made to the original design of the paver or paver must be approved by qualified personnel to ensure that the changes include appropriate guarding and provide a safe working environment for all personnel.
- Wear clothing that fits snug to prevent getting caught in moving parts. Loose-fitting clothing should never be worn.
- Mount and dismount the paver from the rear using only the steps, handrails and walkways provided.
- Do not mount the paver when it is moving.

Decals and Icons

- Allow only the operator on the operator's platform when the paver is in operation.
- Before starting the paver, make sure the brakes are ON, all other systems are OFF and all personnel are clear.
- Before leaving operator's seat, always place the brake switch ON, and all other controls or switches in OFF or NEUTRAL position.
- Reduce travel speed when going down step grades to prevent over-speeding.
- Do not allow personnel near the hopper area when the paver is running.

Caution

- Wear protective mask when harmful air pollution exists.
- Wear safety goggles, gloves and long-sleeve shirts when working near hot asphalt materials.
- Wear ear plugs while paver is running.
- Keep operator's platform, steps and screed walkways clear of all obstructions, tools and other items to prevent tripping or falling.
- To prevent fire hazards, keep the screed and engine basket area free of oil, asphalt and trash buildup.

Decals and Icons

Beneath all safety regulations lies a set of common-sense rules. Everyone who works with or near heavy equipment must be aware of those rules. To foster and maintain such an awareness in our customers, safety decals are fixed on our equipment.

Icons on our safety decals remind both workers and supervisors of common hazards and procedures that, in a course of a busy day, they might otherwise forget. The language of the icons is simple direct. Refer to (Figure 4) to see safety decals used on this equipment

Safety Decal Location

Safety Decal Location

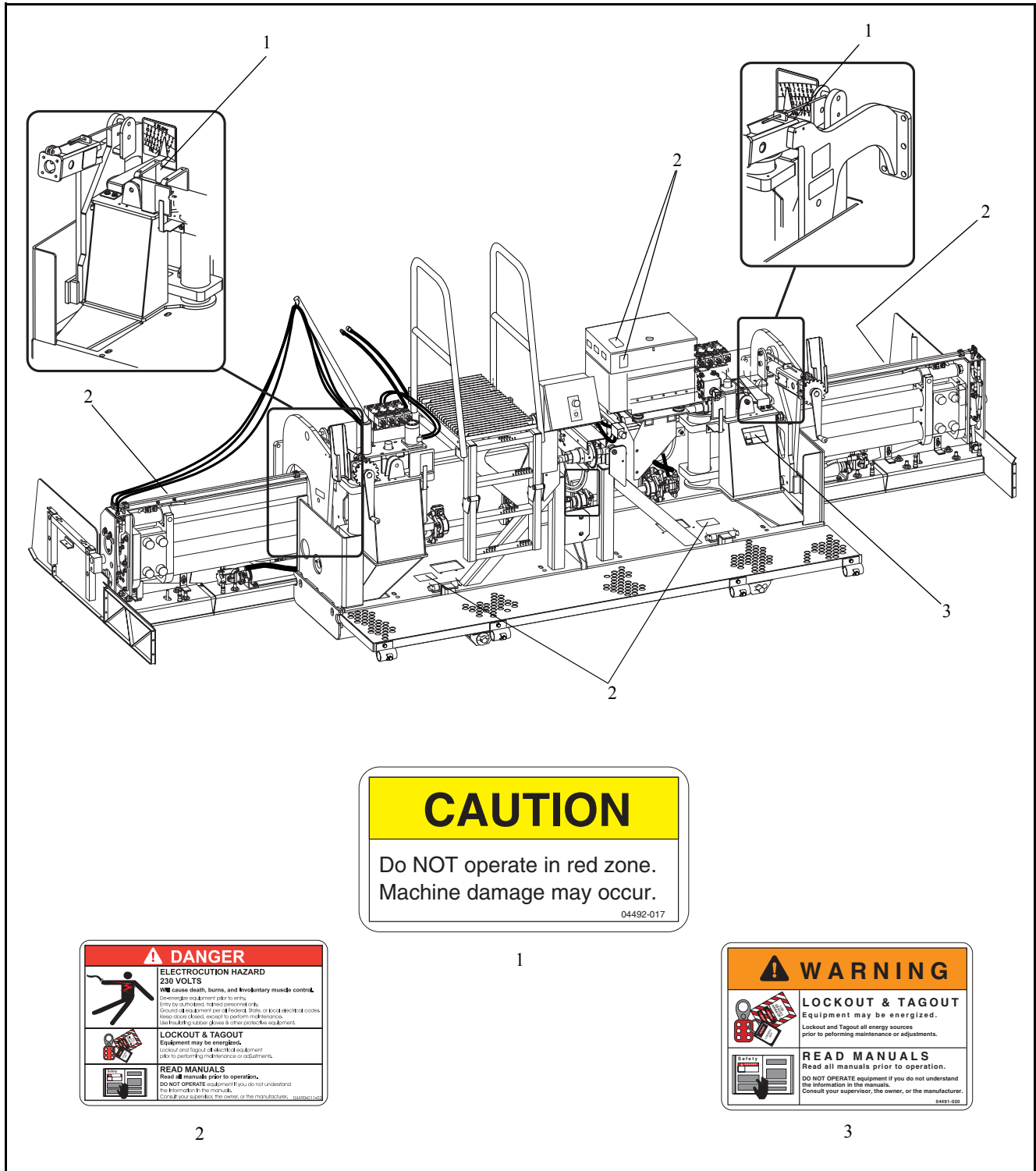

CAUTION

Do NOT operate in red zone.
Machine damage may occur.

04492-017

⚠ DANGER

ELECTROCUTION HAZARD
230 VOLTS

⚡ cause death, burns, and involuntary muscle control.

Disconnect equipment prior to entry.
Entry by authorized, trained personnel only.
Ground all equipment per all locked, stop, or lock electrical codes.
Wear safety glasses, especially to perform maintenance.
Use handoutlet rubber gloves & other protective equipment.

LOCKOUT & TAGOUT
Equipment may be energized.
Lockout and Tagout all electrical equipment
prior to performing maintenance or adjustments.

READ MANUALS
Read all manuals prior to operation.
DO NOT OPERATE equipment if you do not understand
the information in the manuals.
Consult your supervisor, the owner, or the manufacturer, as applicable.

⚠ WARNING

LOCKOUT & TAGOUT
Equipment may be energized.
Lockout and Tagout all energy sources
prior to performing maintenance or adjustments.

READ MANUALS
Read all manuals prior to operation.
DO NOT OPERATE equipment if you do not understand
the information in the manuals.
Consult your supervisor, the owner, or the manufacturer.
04491-029

Figure 4 Safety Decal Location



Receiving New Equipment

Receiving New Equipment

Before accepting and unloading a new paver and/or screed, the consignee must inspect the equipment for evidence of damage or missing parts. This inspection process should be thorough, because once the freight receipt is signed, it is assumed that all of the equipment listed on the receipt was received in good condition.

Make a thorough inventory of all loose components packaged in boxes. A check list is provided in each box listing the components in the box. While performing the inventory, inspect all loose components for damage which may have occurred during transit. Any damage that happens to the equipment in transit is the responsibility of the carrier **not** Terex Cedarapids. Claims for damage must be submitted to the carrier for settlement.

When evidence of damage or loss is discovered, have the driver make a notation on both the carrier's and consignees' copies of the freight bill. Prior to signing the freight bill, take pictures of the damage and identify the truck if possible. The consignee can then sign the bill to acknowledge delivery. The consignee should then have the carrier's terminal manager or his authorized representative make an official inspection of the damage or loss.

Equipment should not be moved from the original receiving point until this official inspection has been made. Good clear photos will verify and explain damage in any claim action which may follow. When the inspection is done, the consignee should file a written damage claim with the carrier's office and should report this action to the area distributor for Terex Cedarapids.

If hidden damage is found after the carrier's representative has gone, do not continue to unpack or move the equipment. Contact the carrier's local office and have the terminal manager or authorized representative make an immediate personal inspection of the damage. Obtain a written description of the damage, and photos if possible, signed by the representative as proof of a valid claim.

A packet of equipment warranty/start-up information will be sent to the distributor before the equipment leaves the factory. All warranty/start-up forms must be filled out and returned to Terex Cedarapids within **24 hours** after the equipment is received.

Principle Of Operation

Principle Of Operation

A screed applies and compacts one or more layers of hot mix asphalt to create a smooth well-drained road surface. The screed is towed by the tractor that has adjustable pull points. The combination of the pull point height positioning and mat thickness hand crank adjustments provide for changes to be introduced to the screed attack angle. The slight positive angle of attack allows the screed to ride up and float on the hot mix.

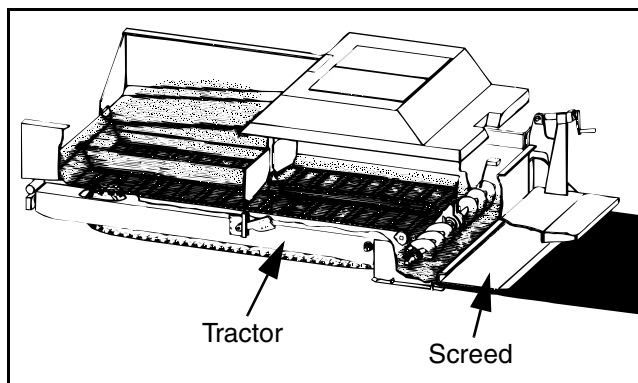

Figure 5 Asphalt Flow

Vertical movement of pull points will cause the attack angle of the screed bottom to change. This, in turn, causes the screed to establish a new level. This self leveling action of the screed keeps the mat surface at a uniform grade.

The screed also has electrically operated heating units to warm the screed bottom prior to paving. Preheating the screed bottom allows the hot asphalt to pass under the screed without sticking to the cold screed bottom.

The electric heating units are supplied electricity from a hydraulically driven generator mounted on the screed. The tractor must be equipped with a circuit to supply the hydraulic drive motor.

The screed bottom flexes at its midpoint into a slight V-shape (negative crown) or into a slight inverted V-shape (positive crown). Such adjustment produces a negative or positive crown on the mat for specified water drainage requirements.

Equipment Description

Equipment Description

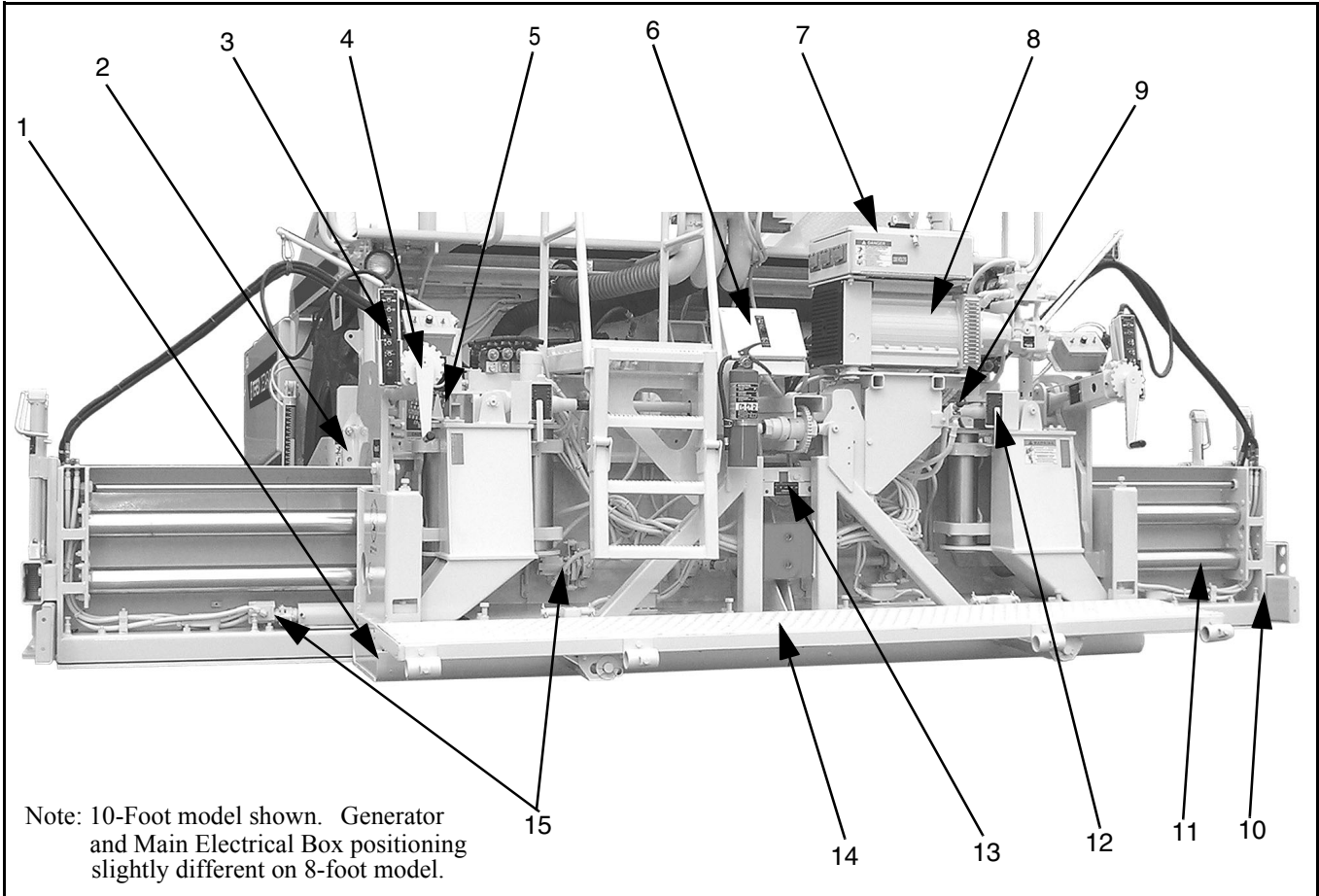

Figure 6 VersaScreed

- | | |
|---|---|
| 1) Main Screed Section | 9) Vibrator Control |
| 2) Left/Right Pull Arm Mount | 10) Left/Right End Gates |
| 3) Left/Right Remote Screed Control | 11) Left/Right Extending Screed Sections |
| 4) Left/Right Depth Crank | 12) Match Height Indicator |
| 5) Left/Right Slope Indicator | 13) Crown Indicator |
| 6) Main DC Electrical Box | 14) Walkway |
| 7) Heater Control Panel (w/locking access door) | 15) Left/Right Vibrators (main screed and extensions) |
| 8) Generator | |



Equipment Description

- 1) **Main Screed Section**
- 2) **Pull Arm Mount** - The screed is connected to the tractor at the pull arm mount.
- 3) **Remote Screed Control** - Portable control panel used to adjust match height, slope, mat thickness, extension width and feed control.
- 4) **Depth Crank** - Adjusts the angle of attack of the main screed bottom to increase or decrease the thickness of the mat.
- 5) **Slope Indicator** - The extending screed sections can be tilted independently as needed to produce a sloping mat surface.
- 6) **Main DC Electrical Box** - Junction box for screed control electrical connections. Contains the horn switch, generator ON/OFF switch and the crown adjustment switch.
- 7) **Heater Control Panel** - Contains heater circuit breakers, 120/240V circuit breakers, heater on/off switch, and temperature controllers for heating the screed bottoms.
- 8) **Generator** - Hydraulically powered generator provides the electricity necessary for the heating units to prevent asphalt from sticking to the screed bottom.
- 9) **Vibrator Control** - Indexed hydraulic valve to adjust the speed that the vibrators run.
- 10) **End Gates** - Mounted on the end of the extending screed sections. The end gates prevent material from spilling out past the end of the extending screed section and produce a square or bevelled edge on the mat.
- 11) **Extending Screed Sections** - Extending screed sections can be adjusted hydraulically to any width from zero to three and one half feet (0-3 1/2') on each side for a 10-foot screed or 0-2 1/2' on each side for an 8' screed.
- 12) **Match Height Indicator**- Extending screed sections can be raised or lowered as needed to match the height of the main screed bottom.
- 13) **Crown Indicator**- The main screed bottom can be deflected at the center to produce a positive or negative crown in the mat.
- 14) **Walkway** - Allows screed operator to move along the length of the main screed while the screed is in motion without walking on the newly placed mat.
- 15) **Vibrator** - Vibrators increase the compaction produced by the screed. Vibrator frequency and amplitude can be adjusted for mat and mix specifications.

Electrical System Operation

Electrical System Operation

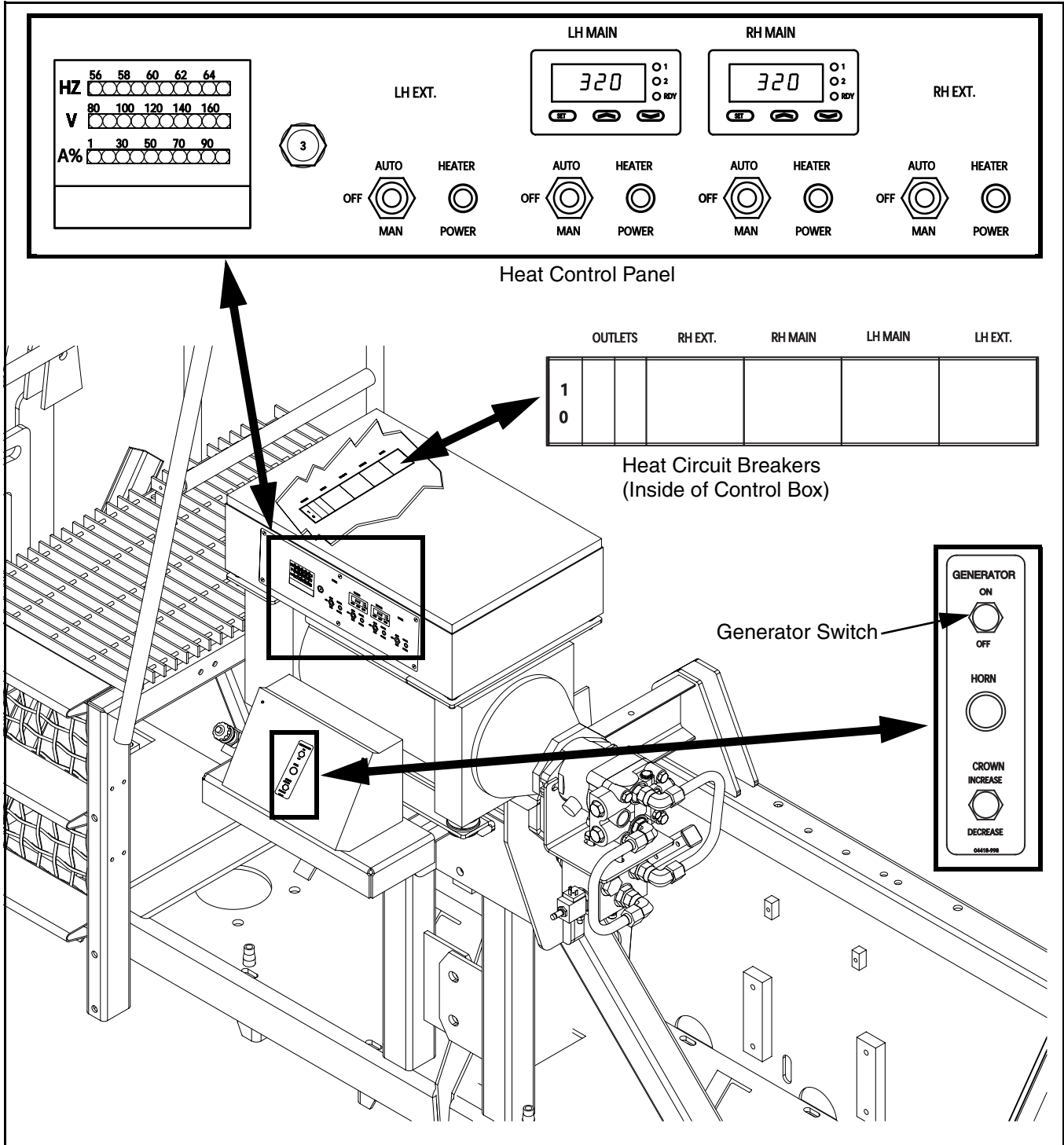

Figure 7 Screed Electric Controls and Indicators

Electrical System Operation

Control Panel Functions

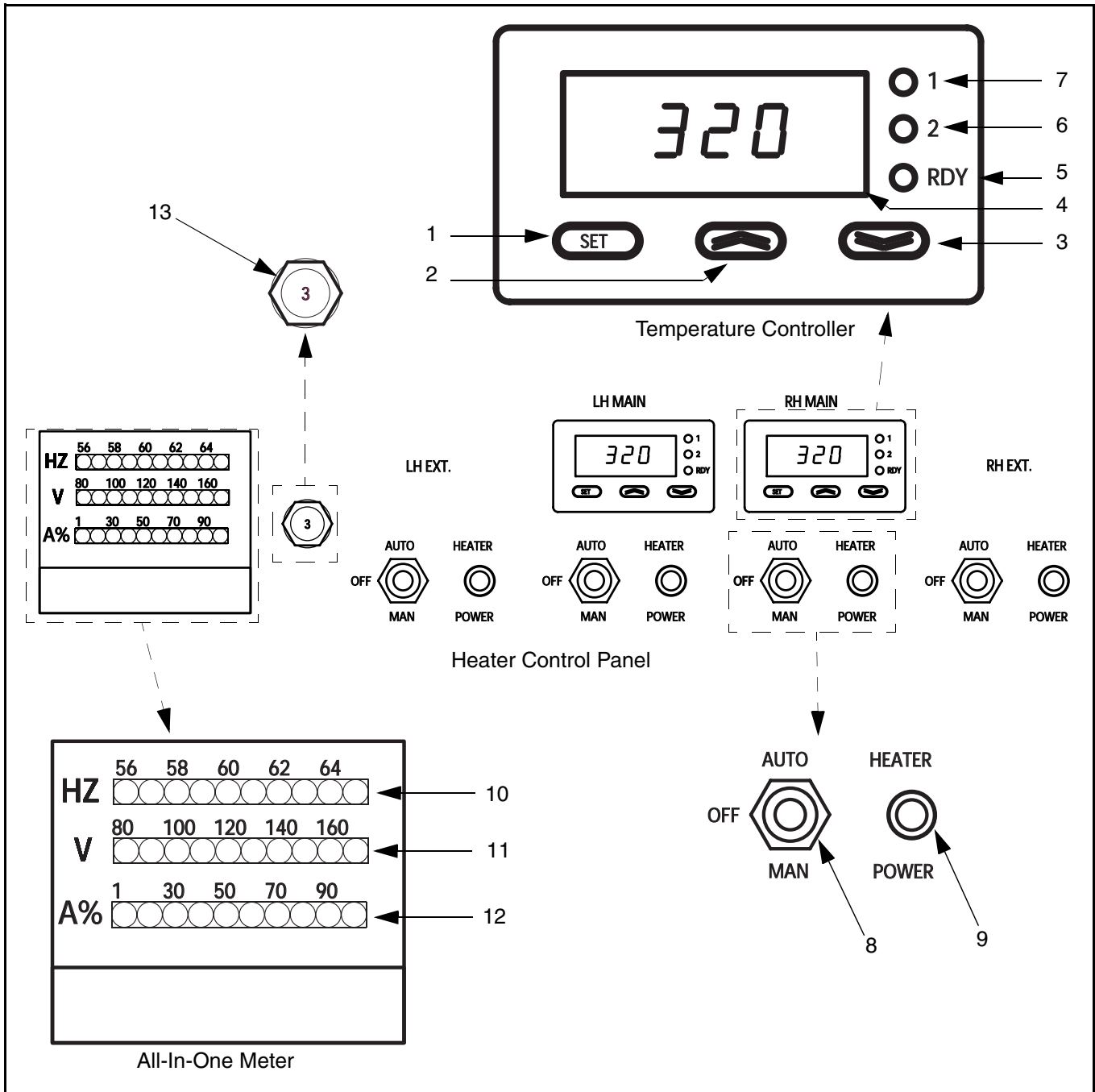

Figure 8 Screed Heater Control Panel

Electrical System Operation

The screed heater control panel (Figure 8) is designed to provide ease of operation and the ability to monitor and control the heating of the screed electrical components.

The function of each control is outlined below:

Temperature Controllers

The control panel has two individual temperature controllers. The left hand (LH) controller is for the left main section of the screed and left extension. The right hand (RH) controller is for the right main section and extension. Each controller unit contains components to allow setting and monitoring of temperature adjustment for the corresponding screed sections. The temperature controllers are only active when the respective control switch is set to AUTO (see item 8).

1) Temperature Controller Set Button

Indicates screed section temperature set point when the button is depressed. Used in conjunction with either the Temperature Up (see item 2) or Temperature Down (see item 3) buttons to adjust the temperature settings of the respective screed section. When a set button is released, controller reads the actual screed section temperature.

2) Temperature Up Button

With the Set button depressed, pushing the Temperature Up button raises the temperature set point of the respective screed section.

3) Temperature Down Button

Pushing the Temperature Down button lowers the temperature set point of the respective screed section with the set button depressed.

4) Temperature Controller Display

The Temperature Controller Display is a digital display meter which shows either the actual temperature or the temperature set point of the respective screed section depending upon whether the set button is depressed or released.

5) Temperature Controller Ready Light

Non-functional Light Emitting Diode (LED) indicator.

6) Temperature Controller #2 Light

LED indicator illuminates when actual screed section temperature is *lower* than the set point. LED light goes out when temperature reaches set point.

7) Temperature Controller #1 Light

Non-functional LED indicator.

Section Controllers

8) Screed Section Control Switch

A three-position switch that controls electrical power to each screed section temperature controller. When switch is toggled to the AUTO position, it automatically activates the temperature controller for the respective section of the screed. Placing the switch in the MAN position by-passes the automatic temperature controls and allows manual powering of the screed heating element for the selected section.

9) Screed Section Heater Power Indicator

LED indicator comes on when screed section heater has electrical power running through it.

Electrical System Operation

All-In-One Meter

The all-in-one meter on the control panel gives a general visual reading of the generator output. LED indicators will light to display generator output status.

10) All-In-One Meter Frequency

LED indicators which come on to indicate the generator's electrical frequency output. Normal frequency should be 58 - 62 Hz.

11) All-In-One Meter Voltage

LED indicators that identify the voltage output for the generator. Normal voltage should be 110 - 130 Volts DC.

12) All-In-One Meter Amperage

LED indicators that identify the output amperage for the generator. The LEDs will go on or off depending on the load as each screed section is powered up or down. With all screed sections heating, the amperage will be @ 50 Amps.

Circuit Breakers

13) Screed Control Panel Circuit Breaker

Circuit breaker that provides protection for screed control panel components.

Screed Heater Operation

Perform the following to operate the screed heaters and pre-heat the screed:

- 1) Start engine and run at 1400 rpm until engine and hydraulic fluid are warm.

NOTICE

Make sure generator switch and all screed section control switches are OFF.

- 2) Turn generator switch ON (Figure 7).
- 3) Turn each screed section control switch to AUTO (Figure 8).

NOTICE

If screed section heater power indicators (Figure 8) do not light, check circuit breakers inside of control box (Figure 7).

- 4) Press set button on temperature controller and, with it depressed, press either the up or down button to adjust that section's set point. Recommended set point is 180° - 240° F.
- 5) Release set button. Temperature display should now read actual screed section temperature.
- 6) Repeat for the other screed sections.
- 7) Wait until all screed sections reach temperature set point before starting paving operation.

Remote Control

Remote Control

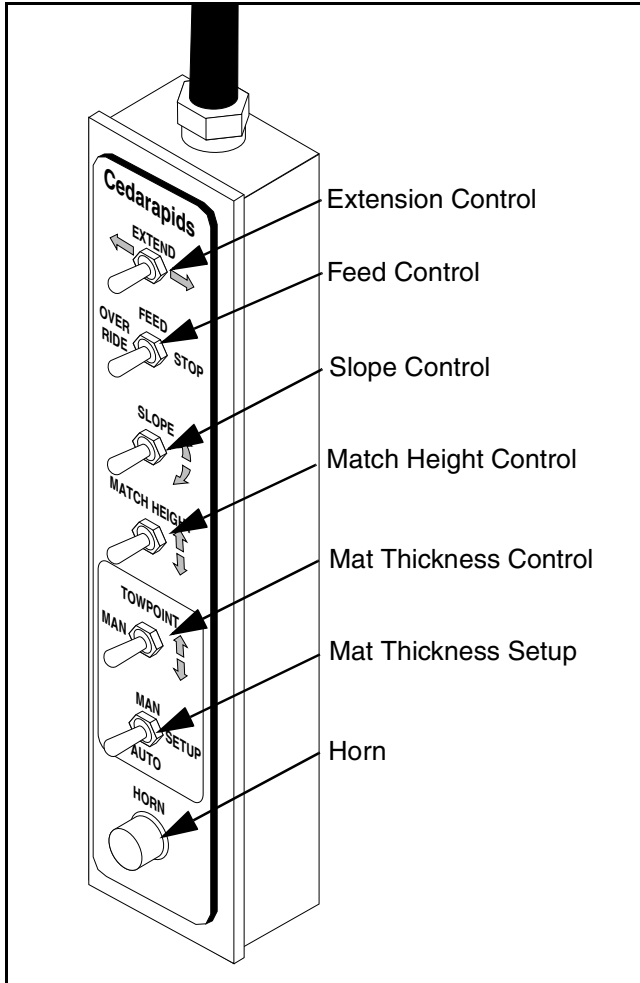

Figure 9 Remote Control Panel

Raising and Lowering Screed



Warning - Always make sure everyone is clear of the screed before raising or lowering the screed.

Raising and lowering the screed is accomplished by two double-acting hydraulic cylinders mounted on the rear of the pull arms. The cylinders are controlled by electric solenoid valves mounted on

the tractors rear bulkhead. The screed is raised using the Screed Lift switch on the tractor operator console.

When engine is at FULL throttle and screed lift switch is held in the RAISE position, the screed will rise until it reaches maximum height or the switch is released. When the switch is released it will automatically return to the neutral position where the screed is hydraulically locked at the existing height. While paving the screed lift switch must be in the LOWER/FLOAT position. This position allows the screed to float over mix at the preset mat thickness.

Supporting an elevated screed



Warning - Always make sure screed is locked in the up position or supported using blocks before working under or around an elevated screed and while traveling with the screed elevated.

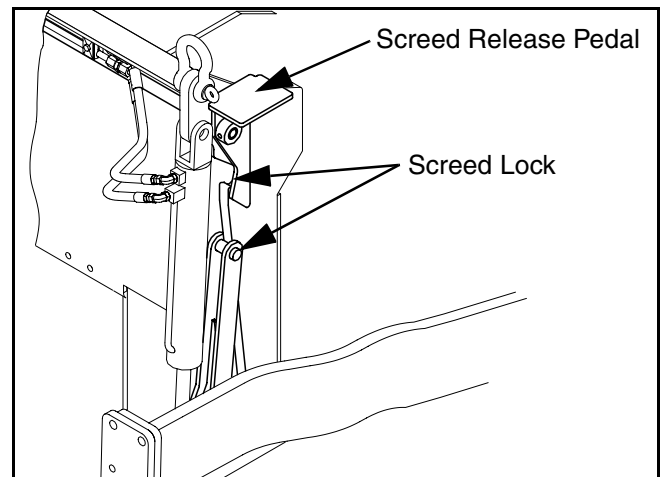

Figure 10 Screed Lock

To lock screed in up position, raise screed to the upper limit until lock engages. To lower, step on screed release pedal and lower screed.

Detaching & Attaching Screed

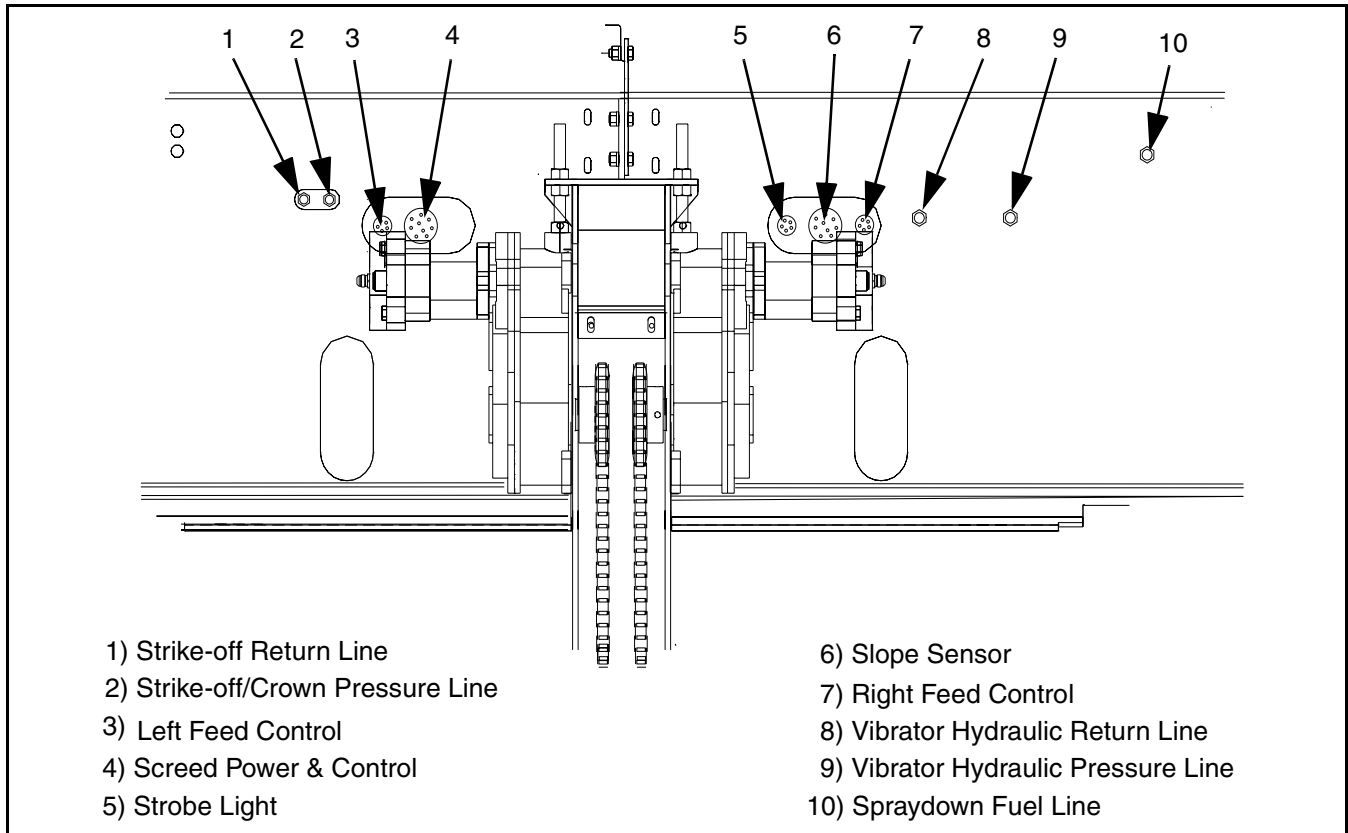

Figure 11 Hydraulic and Electrical Disconnects

Detaching & Attaching Screed

The screed may need to be detached from the tractor because:

- Maintenance and repair work on screed and/on rear of tractor can be more easily performed with screed removed.
- A screed with extensions can be detached and hauled lengthwise on a truck bed.
- Smaller trucks can be used to transport separated tractor and screed.
- The tractor can be driven on a steeper ramp with the screed removed than with the screed installed.

Notice - Screed detachment must be performed correctly to prevent damage to the screed or tractor.

- 1) Lower the screed to the ground.
- 2) Unplug all hydraulic hoses and electrical cables from tractor. Plug or cover the open connectors on both the tractor and on the ends of the hoses or wires using protective covers.
- 3) Remove the four bolts on each pull arm coupler and move tractor forward.
- 4) To attach screed, reverse above procedure.

Operating the Screed

Operating the Screed

Mat Thickness Control

The screed angle of attack (Figure 12) must be adjusted based on desired mat thickness and mix design. Refer to the Quality Paving Guide for detailed instructions on how to determine the correct angle of attack setting.

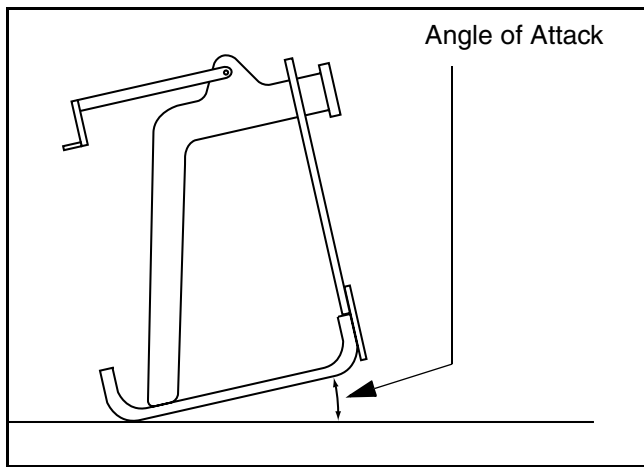

Figure 12 Screed Angle of Attack

Thickness of material deposited is determined by the height of screed pull arm tow points on the tractor and the screed angle of attack in relation to the tow points.

Screed bottom attack angle adjustment is made by vertical movement of tow points (Figure 13). Use the mat thickness switch (INCREASE or DECREASE), on remote control box, to alter pull point height. This method of attack angle adjustment should be the primary means of obtaining the desired mat thickness in the MANUAL mode.

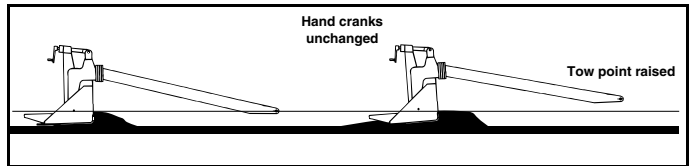

Figure 13 Angle Change Moving Tow Point

Manual attack angle adjustment (mat thickness) can be made by turning hand crank at each end of screed (Figure 14). When hand cranks are turned clockwise, they increase the screed attack angle producing a thicker mat. When the hand cranks are turned counterclockwise, they decrease the screed attack angle producing a thinner mat. If the screed was purchased with opposite rotation, the rotation directions will be reversed.

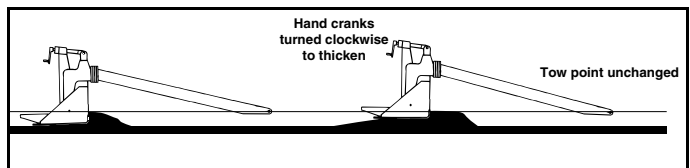

Figure 14 Angle Change Moving Hand Crank

Mat thickness, at each end of screed, is controlled independently so that a tapered mat can be laid in order to level or to super-elevate a roadway.

A change of material may cause screed to react differently, requiring different settings. To obtain a smooth mat, screed adjustments should be made gradually and screed should travel a few feet before an additional adjustment is made. This allows screed to seek new level of operation.

If a paver is equipped with automatic screed control, the operator will normally set up the screed using manual adjustments before switching on the automatic system. Both tow points should be adjusted to the same height at start-up.

Operating the Screed

Screed Pull Arms

Screed pull arms are attached to the paver at a single point (tow point) on each side of the tractor (Figure 15). As the tractor follows the contour of the existing road surface, the pull arms are allowed to move independently to maintain a consistent line of pull. This system allows the screed to cover over irregularities found in grade and base material and produce a new smooth ride surface.

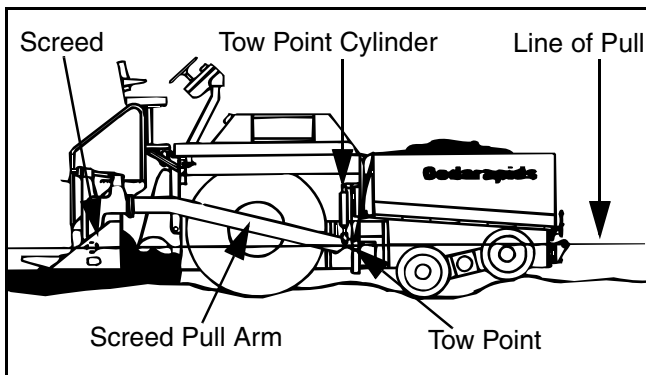

Figure 15 Pull Arms

Tow Point Cylinder Speed Test

Speed adjustment (flow control) valves are included in the hydraulic system for each tow point cylinder so the speed of mat thickness correction can be regulated. These valves make very fine control of flow possible.

The flow control valve is factory set and should not require a change. If one or both tow points react too slow or too fast to changes in grade line, the following test should be performed.

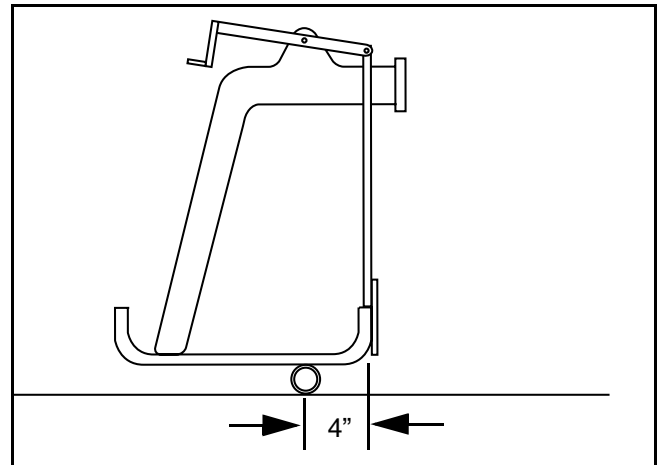

Figure 16 tow point speed test

- 1) Place the paver on a flat hard surface. Place a 2" (O.D.) or larger pipe under each end of the main screed to serve as a pivot (Figure 16). Lay pipe parallel to leading edge of the main screed and exactly 4" from leading edge.
- 2) With engine running at FULL throttle, hydraulic oil at operating temperature, set mat thickness switch, on remote control box, to MANUAL.
- 3) Use the mat thickness switch (INCREASE/DECREASE) and stroke the cylinder from one end of stroke to the other. Total time required should be between 18 to 20 seconds in each direction.
- 4) If not, adjust the tow point flow control valve on the tractor as needed to get the stroke time within the 18 to 20 second range.
- 5) Perform this procedure on both the left and right tow points to ensure both move at the same speed.

Operating the Screed

Tow Point Position

Screed tow points are raised or lowered by tow point cylinders controlled by the mat thickness switch on remote control box. For normal types of material and mat thickness, the tow point cylinders should be set at midstroke. A decal mounted on the tow point cylinders indicates the current position of each tow point (Figure 17).

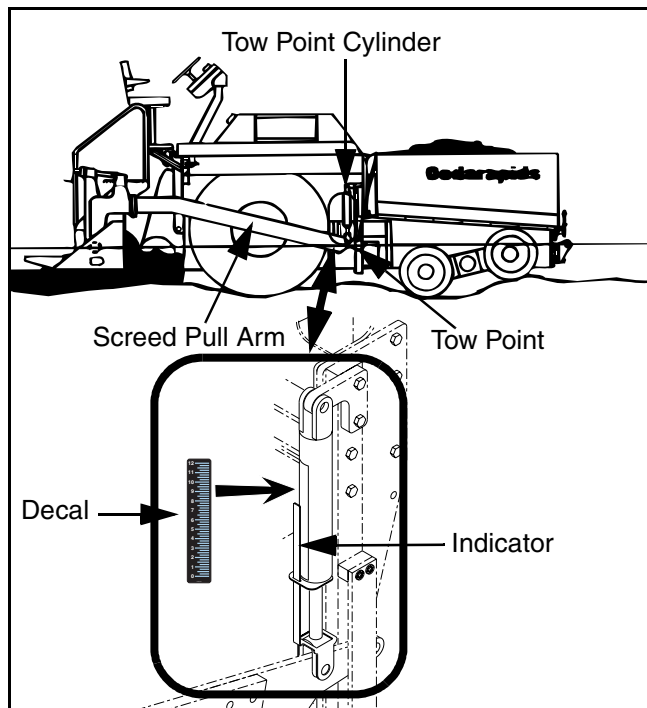

Figure 17 Tow Point Indicator

Notice - The tow points should be reset to the midpoint, depending on depth for line of pull, and the screed nulled at the start of each day. When adjusting tow points to the desired setting, make sure both are adjusted the same. If tow points and hand cranks are excessively out of balance, it causes the screed to twist resulting in poor mat surface.

The tow point most critical settings are with low stability sandy mixes. If screed tends to sink and ride on trailing edge due to unstable mix or a thick mat requirement, tow points can be raised to improve mat. If the paver is required to lay a very thin mat, tow points can be lowered to give screed better flotation and greater initial density to mat.

Correct tow point settings become a matter of experience. Locating mid-stroke of tow points as noted has proven satisfactory for most paving jobs. The softer and more unstable the material, the more important it becomes to have screed bottom flat with mat.

Notice - Unstable mixes can be caused by too much asphalt in mix, poor gradation, poor quality asphalt, excessive temperature, moisture in material, and/or insufficient dust.

Effects of Tow Points Positioned Too High

When pull points are too high and the screed is adjusted to compensate for this, the screed bottom will wear more on the leading edge. See Figure 18. This could cause some of the following problems:

- 1) Premature failure of leading edge of screed bottom and possible damage to strikeoffs.
- 2) Bumpy, wavy mat caused by screed riding on its leading edge.
- 3) Tendency for screed to dip each time paver starts moving.
- 4) Torn mat caused by "digging in" action of leading edge.

Operating the Screed

- 5) Loss of compaction caused by trailing edge of screed not being in contact with mat being laid. Vibrators connected to screed bottom support will not be operating efficiently as full screed width is not being utilized. Mat appearance and texture will change with only slight movement of mat thickness hand cranks.

Effects of Pull Points Positioned Too Low

When pull points are too low and the screed is adjusted to compensate for this, the screed bottom will wear more at the trailing edge. See Figure 18. This could cause some of the following problems:

- 1) Premature failure of trailing edge of screed bottom.
- 2) Tendency for screed to climb each time paver starts moving. Poor control of mat thickness will exist and good transverse joints will be difficult to make.
- 3) Possible tearing of mat caused by excessive ironing effect of screed.

Correct Tow Point Position

Correct tow point positioning will result in more uniform wear of the screed bottom as well as better mat texture. See Figure 18.

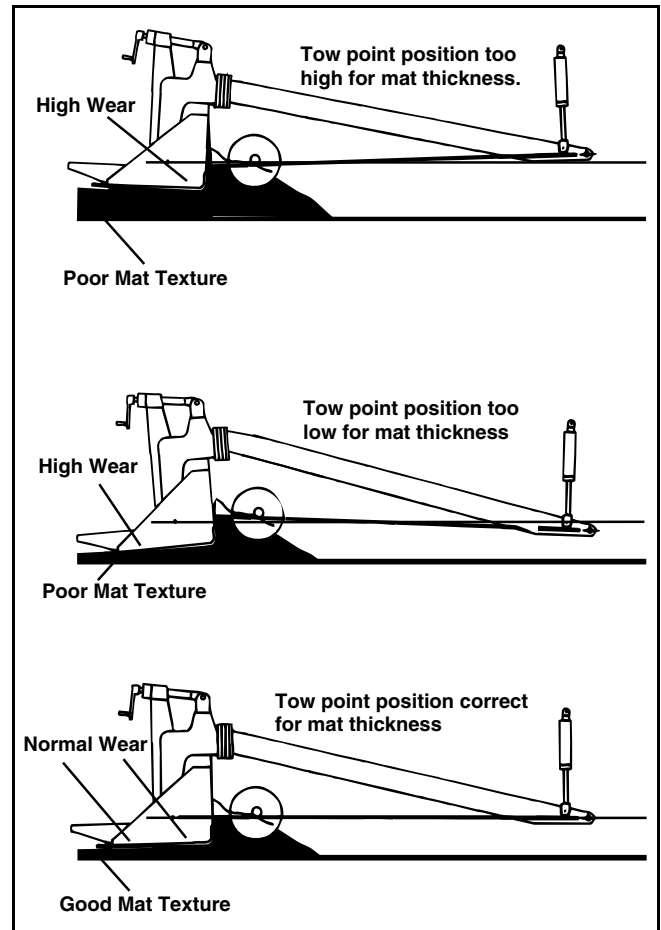

Figure 18 Effects of Tow Point Position

Screed Adjustments

Screed Adjustments

General

All screed adjustments in the following sections should be made only after setting the tow point cylinders to the same position, nulling screed, and zeroing the lead and trailing crown.

Position Tow Points

Use the Manual Jog switch to reposition both tow points to the midpoint on the tow point gauge.

Nulling the Screed

Measure the distance from the screed frame to the left tow arm plate. (Figure 19)

Measure the distance from the screed frame to the right tow arm plate.

Rotate the right side hand crank as needed until the measurement is equal to that of the left side.

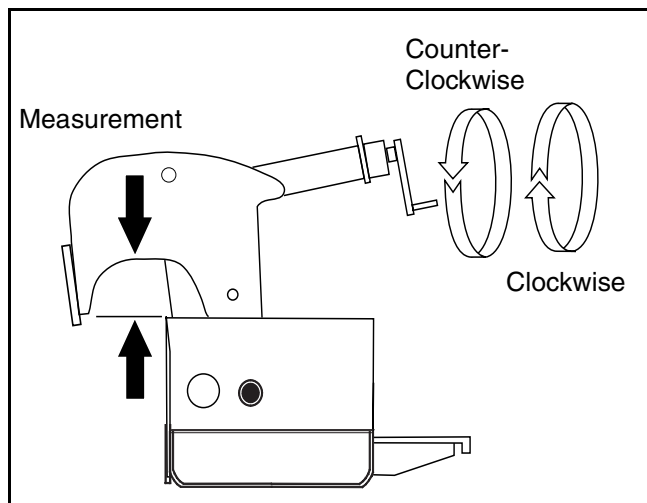

Figure 19 Nulling Screed

Mat Crown Control

The flat screed bottom can be flexed at its center to produce a finished mat having a positive or negative crown for water drainage. For 10' wide paving, maximum positive crown is 3" and maximum negative crown is 1", see Figure 20. The crown gauges provide a crown reference.

Crown adjustment is accomplished by means of two hydraulically driven adjusters (Lead & Trail). The crown adjustment is controlled at the main screed control panel.

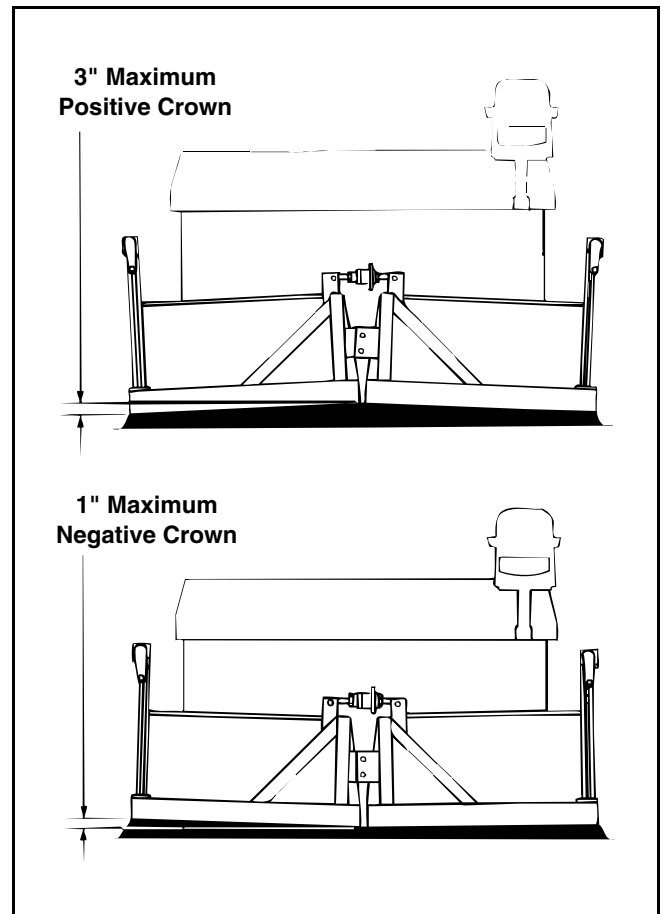

Figure 20 Controlling Mat Crown

Screed Adjustments

Lead/Trail Crown

The main screed crown has two adjusters, the lead & trail. The lead and trail crown can be adjusted simultaneously to add a crown to the final mat. The lead crown can be set independent of the trail, to allow a little extra material to pass into the center area of the main screed. This is necessary to compensate for the void area created by the auger-conveyor drive case. Typically the lead crown is 1/16" to 1/8" above that of the trail. This range is sufficient for most mixes.

The most common way to check the lead and trail crown is to use a strong string line, two equal thickness spacers (new 1/2" NC nuts) and a tape measure.

The first check to be performed is checking and adjusting the trail crown.

- 1) Place two spacers near the outer edge of the screed bottom and just foreword of the trailing edge.

Important - A screed that has been used in a joint matching application may have a few inches on the outer edge of the screed bottom that is worn more than the rest of the screed bottom. In such a situation the spacers will have to be placed inboard of the worn areas to get a proper measurement.

- 2) Stretch a strong string line across the center of the spacers and pull tight.
- 3) Measure the distance from the string line to the screed bottom next to each spacer and in the center of the screed.

- 4) For initial setup purposes we adjust the lead and trail crown to 0" (flat). If the measurement in the center of the screed is less than or more than the measurement near the spacers, the trail crown must be adjusted.
- 5) To adjust, press the crown switch located on the main screed control panel to Increase or Decrease. Adjust until measurement at center area of screed is equal to the measurement near the spacers.
- 6) Once the trail crown is set to 0" (flat), move the spacers and string line forward to the leading edge of the screed bottom.
- 7) Measure the amount of lead crown.
- 8) To adjust the lead crown independent of the trail crown, remove the two clevis pins in the rear crowning sprocket. Press the crown switch to the increase or decrease position.
- 9) Adjust until measurement at center area of screed is equal to measurement at spacers.
- 10) Reinstall the two crown clevis pins in the rear sprocket.
- 11) Once the lead and trail crowns are set at 0" (flat), loosen and reset the crown indicator gauges to 0.

Screed Adjustments

Final Crown Adjustment

Final crown adjustment is made after paving has started and actual mat crown can be accurately checked by taut string line. Final crown adjustment is always made after checking; a) Behind the screed before roller compaction; and b) After roller compaction. Do this after enough mix has been laid to be certain the screed has stabilized. This allows you to check the screed as well as what effect the roller compaction has on the mat shape.

- 1) Place spacers (2 X 4s) near the edges of the newly rolled mat. The spacers must be of equal thickness and be thick enough to hold a stretched string line above the crown of the mat.
- 2) Stretch a string line across the spacers and pull the string line tight.
- 3) Measure the distance from the string line to the mat at the peak of the crown and at each side of the mat near the spacers.
- 4) Adjust the crown as needed recheck the crown of the rolled mat until it matches the specified profile.

Screed Bottom Flatness

The trailing edge flatness must be checked from time to time to ensure the mat produced will be flat across the entire width of the screed.

- 1) Starting from the center line of the screed bottom, place a 5 foot straight edge from the center to the outside edge. The straight edge should be placed along the trailing edge of the screed bottom.
- 2) Check the screed bottom along the length of the straight edge for flatness. If the screed bottom is not flat, loosen the retaining bolt adjacent to the shim bolt and tighten the shim bolt as needed to flatten the trailing edge. Retighten the retaining bolt. (Figure 21)

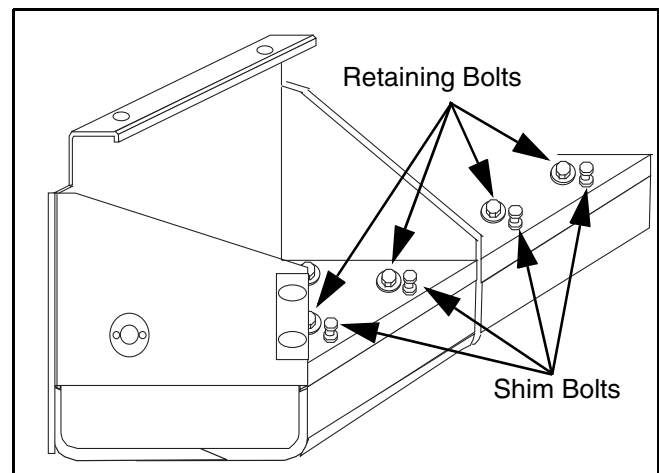

Figure 21 Screed Bottom Flatness

Screed Adjustments

Match Height Adjustment

This adjustment is performed to make sure the extending screeds are positioned at the same height as main screed. Procedures described below are done for both extending screeds.

- 1) With the extending screeds fully retracted, check the match height across bottom of rear extending screed and main screed at outer edge. If the main and extending screed bottoms do not match, use the match height switch on the remote control to raise or lower the extending screed as needed.
- 2) When the outside edges of the screed bottoms are at the same height, check the height at inner edge. If the inner edges do not match, use the slope switch on the remote control to align the inner edges of the screed bottoms.
- 3) When both the inner and outer edges are matched, check match height scale pointer. If pointer is not at zero, loosen cap screws, align with zero, and re-tighten screws.
- 4) Extend the extending screed. Lay a straightedge across the main and extending screed bottoms. Both surfaces should be level if the preceding steps have been performed correctly.

Independent Angle of Attack

The extending screeds run with a slight increased angle of attack relative to the main screed to provide a uniform texture across the width of the mat. This is called the independent angle of attack.

Important - The Match Height Adjustment above must be performed before adjusting the independent angle of attack.

To check and adjust the independent angle of attack:

- 1) Fully retract both extending screeds.
- 2) Place a straight edge on the outer edge of the main screed that extends under the extending screed.
- 3) With straight edge flat against the main screed bottom, the straight edge should contact the extending screed bottom at the trailing edge. There should be 1/8" gap between the leading edge of the extending screed bottom and the straightedge. (Figure 22)

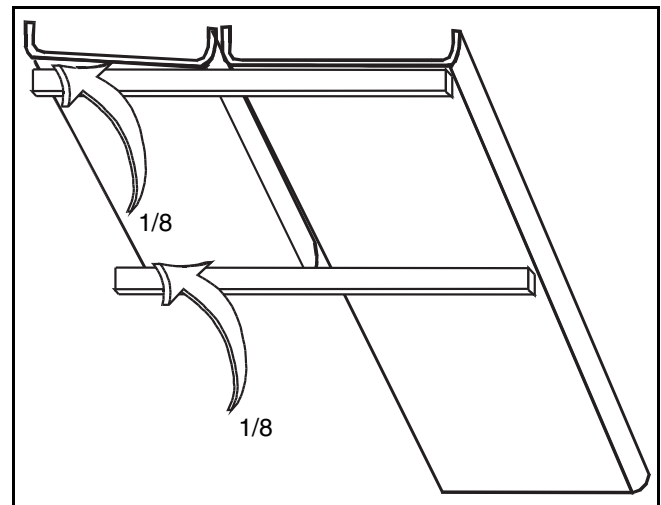

Figure 22 Independent Angle of Attack

Screed Adjustments

Independent Angle of Attack Adjustment

- 1) To adjust the independent attack angle, first loosen rear adjustment rod retaining bolts. (Figure 23)
- 2) Loosen jam nuts on adjustment rod.
- 3) Move adjustment rod downward to increase angle of attack or upward to decrease angle of attack. This will move the tipping frame and thus change the angle of attack of the extending screed bottom.
- 4) Once the desired angle is obtained, re-tighten jam nuts and retaining bolts. (Figure 23)
- 5) Repeat steps 1 through 4 above for each side of the screed.

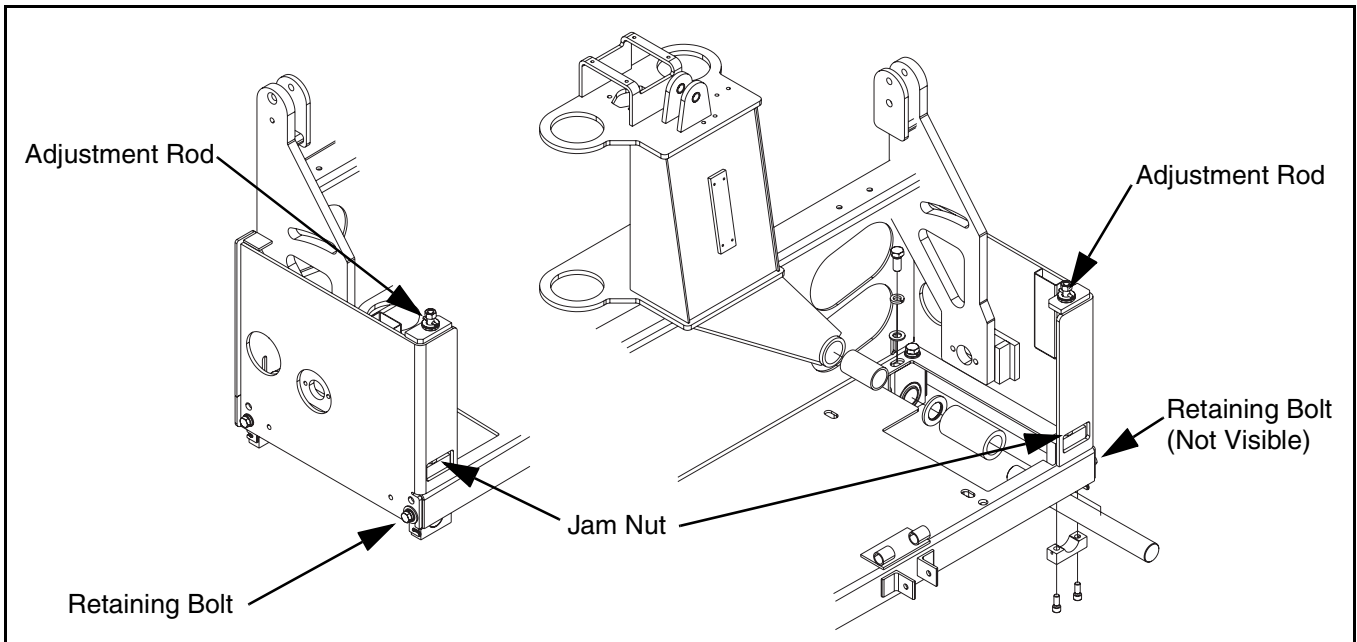

Figure 23 Adjusting Angle of Attack

Screed Adjustments

Extending Screed Alignment

An extending screed that is not parallel with the main screed can still function properly. The most obvious indicator that the extending screed is not parallel to the main screed will be that the extender tubes will be out-of-line. When retracting the screed, tubes may rub or hit part of the structure normally cleared or be noticeably misaligned with tubes of the opposite extending screed. (Figure 25)

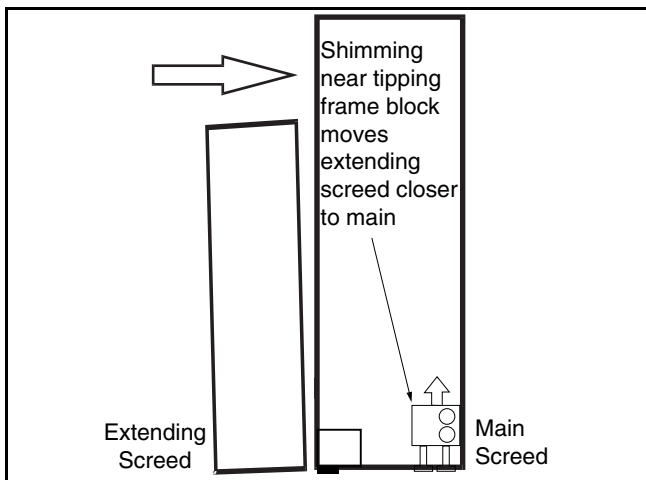

Figure 24 Extending Screed Alignment

To realign the extending screeds:

- 1) Retract both extending screeds.
- 2) Loosen inner and outer keeper bolts.
- 3) Install a press bolt in threaded hole next to the outer keeper bolts and tighten. This causes the tipping frame block and extending screed to move.
- 4) Once the extending screed is aligned with the main screed, add shims between the tipping frame block and main screed frame.

- 5) Tighten the keeper bolts and remove press bolt. (Figure 25)

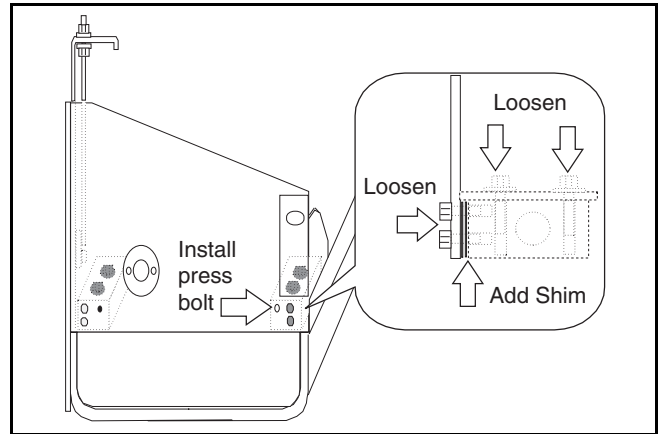

Figure 25 Shim Tipping Frame

Screed Accessories**Screed Accessories****Heaters**

The purpose of the heaters is to raise the temperature of the screed bottom to allow material to flow under the screed bottom without sticking and produce a more uniform mat surface texture. The hot mix will usually maintain proper screed temperature. Since the heaters are thermostatically controlled, they will only come on when needed.

If material delivered to hopper has cooled too much, mat texture may be improved by running heaters. When hauling long distances, it may be necessary to raise the temperature of the mix at the mixing plant to restore efficient production of a high quality mat.

Usually the screed bottom will be heated sufficiently by running heaters for 15 to 20 minutes before operation.

Notice - Excessive heat can cause screed bottom to warp.

Screed Vibrators

Hydraulic vibrators on screed, which help with initial compaction and uniform smoothing of a high density mat, are activated by toggle switch on operator's console. Vibrators will only operate when travel lever(s) is FORWARD. This prevents extra compaction in one place on mat when paver is temporarily stopped.

Operating intensity of vibrators can be varied to produce more or less vibration. The vibrator speed knob (flow control valve) is located adjacent to heater control panel. A recommended start-up setting is 3/4 of range between zero and the highest dial marking.

Operating Screed Vibrator

- 1) With engine running, set paver speed dial to zero (MIN.).
- 2) Turn vibrator switch to ON, set brake switch to RELEASE, and move travel switch/lever forward.
- 3) To turn vibrators off, set vibrator switch to OFF, return travel lever(s) to neutral, and ENGAGE brake switch.



Warning - Do not work on vibrators with engine running.

Screed Accessories

Vibrator Weight Installation and Alignment

Each vibrator weight consists of two plates mounted 120° apart and clamped to the vibrator shaft (Figure 26). There are four pairs of weights, two on each side of the screed, and two motors, one at the outer end of each shaft. Each extending screed has a vibrator and a motor.

Weights are mounted at 120° to each other to produce adequate compaction for most mixes. If more or less compaction force is needed, the relationship of weights in each pair can be changed.

Aligning the weights closer together will produce more compaction force. When both weights are exactly aligned, maximum force is obtained.

Aligning the weights opposite each other counter balances the force and provides no vibratory compaction force.

To reposition a weight, loosen with an Allen wrench and rotate the weight to the desired position. Only one weight will need to be moved.

Important - All pairs of weights must be aligned along the length of the shaft to produce a synchronized vibrating force. This is very important to remember when installing screed extensions equipped with vibrators. Misalignment will reduce vibrating force across the screed affecting the quality of mat compaction.

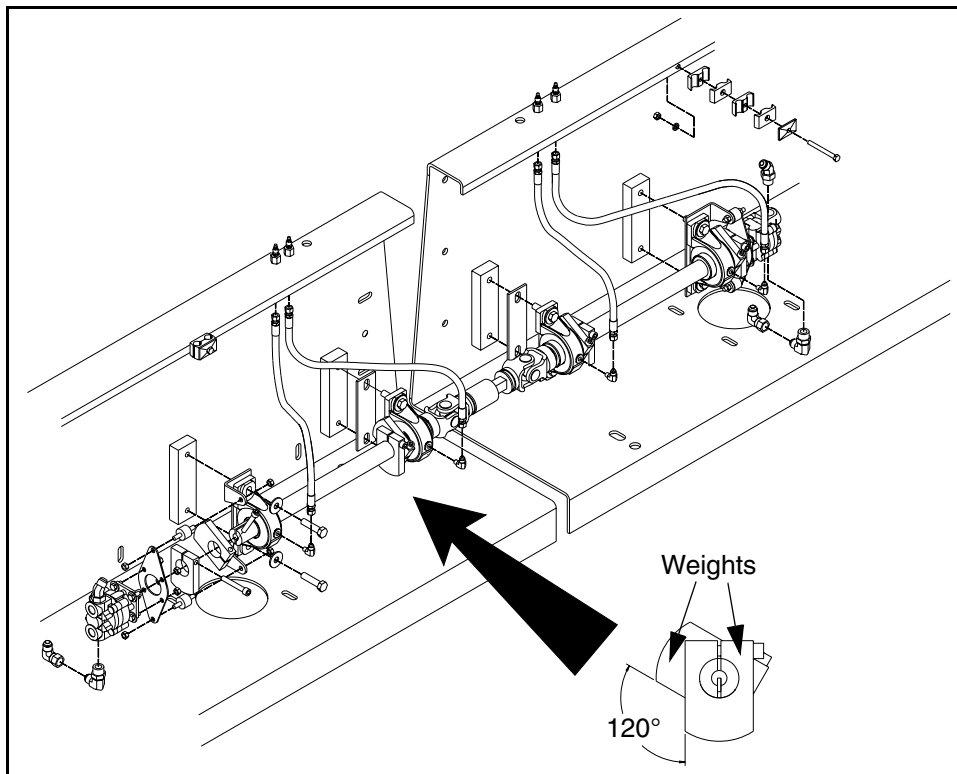

Figure 26 Vibrator Weight Installation & Alignment

Screed Accessories

Strike-Offs

Strike-offs bolted to front of main and each extending screed bottoms meter material to screeds. They also absorb wear which would otherwise take place on leading edge of screed bottoms. If these strike-offs are not properly adjusted and maintained they can cause operational difficulties.

Important - A silicone additive is often added to asphalt to improve mix laying characteristics of hot sand or fine mixes. Use of this additive may require adjustment of the strike-offs.

Adjusting Strike-off

The fixed strike-offs act as a material metering device to control the amount of material allowed to pass under the screed, thereby controlling or affecting the angle of attack required to produce a given depth. They also absorb wear that would have been introduced to the nose area of the screed

bottom. The normal strike-off setting is 1/2 inch above the screed bottom and will work fine with most material designs. (Figure 27) There are some material designs that will require changing the setting to allow the screed to run with the desired 1/8 inch to 1/4 inch nose-up attitude or angle of attack.

To check and adjust the strike-off:

- 1) Place a straight edge against the bottom of the screed and measure from the straight edge to the bottom of the strike-off. (Figure 27)
- 2) Adjust the strike-off by loosening the bottom jam nut on the strike-off adjusters and tightening the top nut to raise the strike-off. Loosen the top jam nut and tighten the bottom jam nut to lower the strike-off.
- 3) Check the strike-off setting at both the inside and outside edges of the screed.

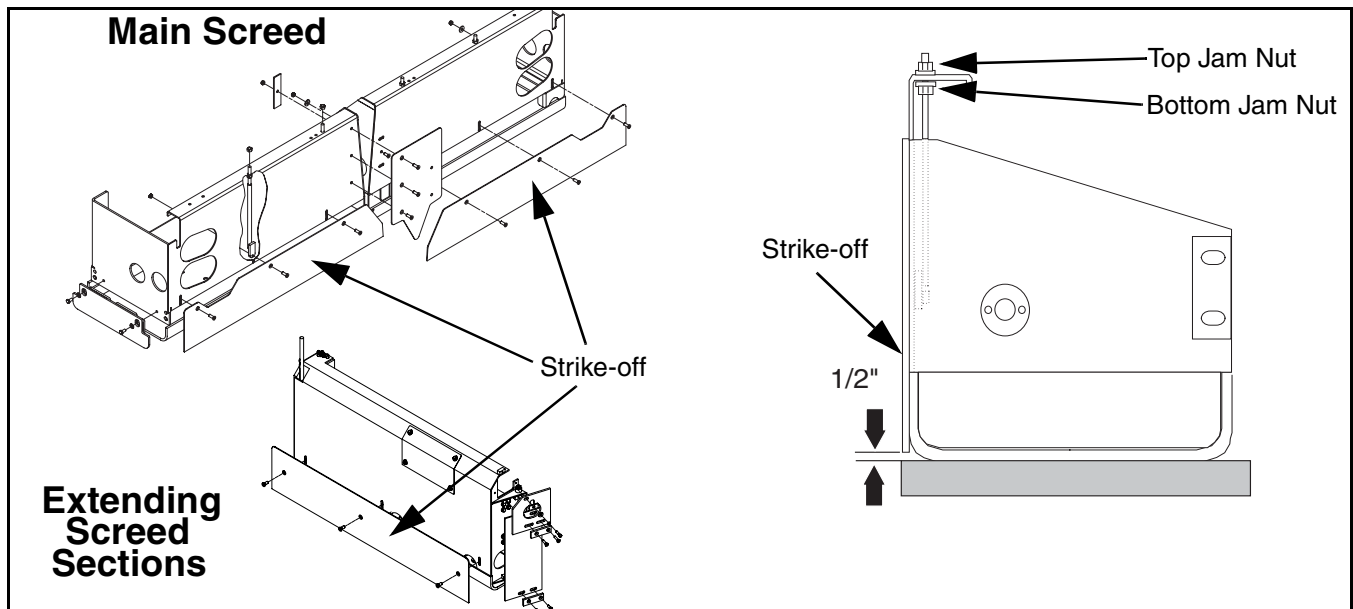

Figure 27 Strike-Off Adjustment

Screed Accessories

Changing Screed Bottom

The screed bottoms will need to be removed from time-to-time for replacement. If the trailing edge of the main screed is worn significantly more than the leading edge, the screed bottom can be removed and turned end-for-end and reinstalled to increase the screed bottom's useful life.

Screed Bottom Removal

- 1) Adjust lead and tail crown to 0" (flat).
- 2) Install two 5/8" x 2" cap screws into the red aligning plates in the center of the screed and tighten securely.

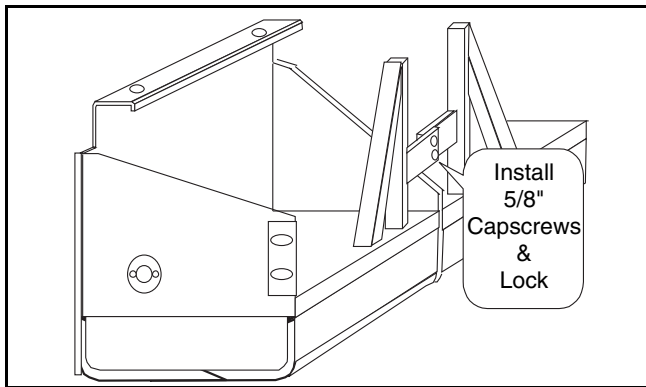

Figure 28

- 3) Loosen nut on cover plate of left inside upper screed frame and rotate plate 90° as shown in Figure 29.
- 4) Install two 1/2" x 2" cap screws in two holes and tighten, locking front of the upper screed frames together.

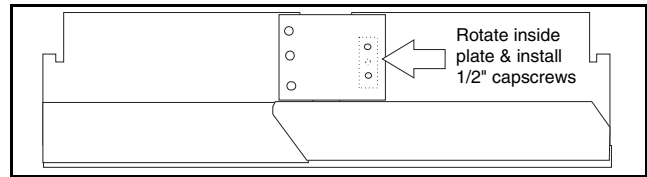

Figure 29

- 5) Set the screed down on a flat level area.
- 6) Remove the 3/4" retaining cap screws from rear and front of upper screed frames (8 main screed, 4 per extending screed).

NOTICE - Do not loosen or attempt to adjust the shim bolts located on the main screed. They are set at the factory so the screed bottom when installed is parallel with the upper frames.

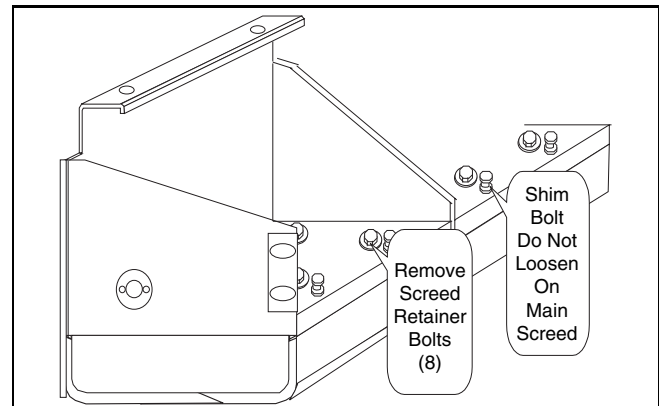

Figure 30

- 7) Raise the screed frames up away from the screed plate. Drive the paver forward a short distance.
- 8) Inspect and clean the back side of the fixed strike-offs of all built-up asphalt materials.
- 9) Inspect and clean the screed heaters.

Screed Accessories

10) Measure distance from screed bottom lip to screed sub-frame at both ends of each sub-frame. These measurements will be used to install sub-frames on a new screed bottom.

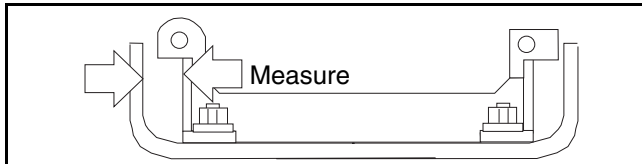

Figure 31

11) Remove the 5/8” nuts on the rear and front of both screed sub-frames. Remove flat washers and lift sub-frames off old screed bottom.

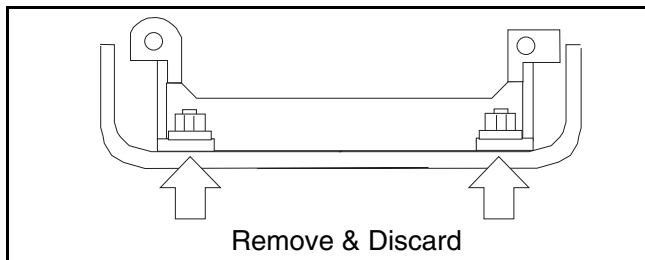

Figure 32

Screed Bottom Installation

- 1) Place NEW screed bottom on a flat level surface.
- 2) Place the screed sub-frames over the studs on the new screed bottom.
- 3) Place one flat washer on each stud and start NEW 5/8” lock nuts.
- 4) Measure the distance from the screed bottom lip to the sub-frame and adjust to the dimensions previously taken when removing screed bottom.

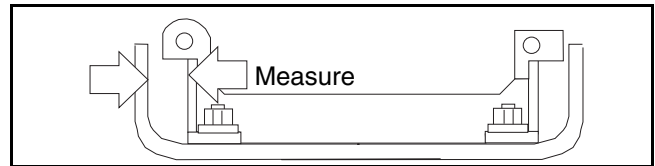

Figure 33

- 5) Tighten 5/8” lock nuts to 85 foot pounds torque.
- 6) Position paver over screed bottom and align.
- 7) Lower upper screed frame onto screed bottom and sub-frame.
- 8) Install the eight 3/4” retaining cap screws and torque to 266 foot pounds torque.

NOTICE - Do not loosen or attempt to adjust the shim bolts located on the main screed. They are set at the factory so the screed bottom when installed is parallel with the upper frames.

Cleaning the Screed**Cleaning the Screed**

It is extremely important that screed and paver be thoroughly cleaned at end of each day's operation! A spray nozzle with 30' hose is attached using a quick-disconnect to the pressure side of fuel pump. This permits operator to reach all areas of paver that require cleaning and lubricating.



Warning - Do not operate spray down system when screed heaters are on or generator is operating.

- 1) Turn main key switch ON. If extensive cleaning is required, run engine at IDLE speed.
- 2) Remove hose assembly from tool box and connect to the quick-disconnect.
- 3) Turn fuel pump ON.
- 4) Fully extend extending screeds. Spray and clean the screed bottoms, strike-offs, and seal plate area. Periodically check for accumulation of asphalt that has spilled over extension moldboard.
- 5) Clean all parts of paver that come in contact with asphalt. Front, bogie assemblies, hopper, slat conveyors, augers, screed, etc. require cleaning at end of each day. This holds true even if paver was used only a short time. Many troubles can be traced to improper cleaning! Fuel oil on slat conveyors provide needed lubrication that prevents rapid wear. Slat conveyors should be operated during spraying to be sure chain and all slats are reached.

Notice - Keep oil spray away from all electrical boxes. Avoid spraying rubber hoses and cables with fuel oil as this may cause some deterioration over a period of time.



Warning - Keep open flame, sparks, welding arcs, etc. away from screed where there are flammable materials present such as fuel oil

Lubrication**Lubrication****General**

Proper lubrication and daily cleaning are the most important factors in bearing life. Follow the recommended lubrication intervals. Be sure to clean all grease zerks and grease gun tip before greasing. During your daily cleaning and lubrication procedures, inspect the seal area for signs of a blown seal. Over-greasing or greasing when the bearings are cold is the biggest reason for blown seals.

Depth Cranks

The screed depth crank assemblies have two lubrication points on each, one on the threaded link and the other on the screed depth crank bearing housing. These should be lubricated every 40 hours of operation. One to two pumps from a hand grease gun is all that is necessary.

Vibrator Bearings

The main screed vibrator assemblies have four lubrication points, one on each vibrator bearing. The extending screed vibrator assemblies have two lubrication points, one on each bearing. All should be lubricated every 8 hours of operation. One to two pumps from a hand grease gun is all that is necessary.

Match Height

The match height assemblies have two lubrication points on each, one on the threaded link and the other on the match height bearing housing. These should be lubricated every 40 hours of operation. One to two pumps from a hand grease gun is all that is necessary.

Extending Screed Slope

The extending screed slope assemblies have two lubrication points on each, one on the threaded link and the other on the slope shaft bearing housing. These should be lubricated every 40 hours of operation. One to two pumps from a hand grease gun is all that is necessary.

Crown

The crown has two lubrication points, one on each turnbuckle assembly. They should be lubricated every 40 hours of operation. One to two pumps from a hand grease gun is all that is necessary.

Tractor Generator Pump Plumbing

Tractor Generator Pump Plumbing

Adding or removing the electric screed from a tractor requires changes to the tractor generator pump plumbing configuration. The generator pump load sensor hydraulic line is either connected to the generator drive motor or connected on the tractor in the bypass mode respectively.

CAUTION

Make sure generator pump plumbing is properly connected prior to operation of the generator.

Attaching Screed to Tractor

When the screed is attached to the tractor, the generator pump load sensor line must be connected to quick connect fitting on the screed's generator drive hydraulic motor. See (Figure 34) for the VersaScreed 10 foot connection. See for the VersaScreed 8 foot connection.

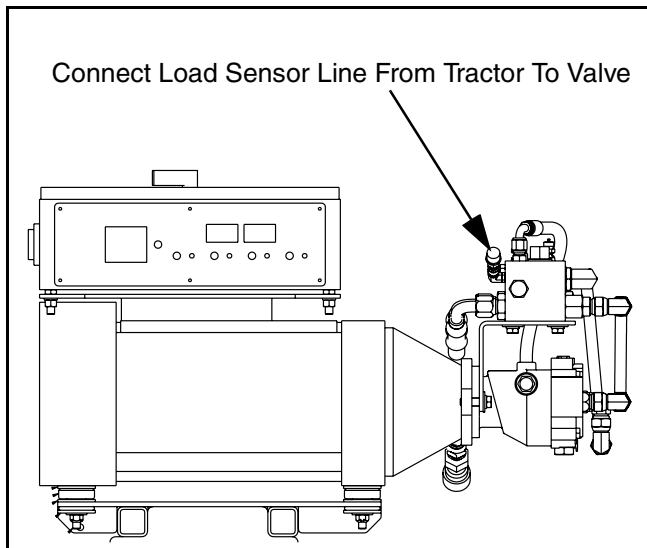

Figure 34 Tractor Generator Pump Connection on 10-Foot Screed Generator Drive Motor

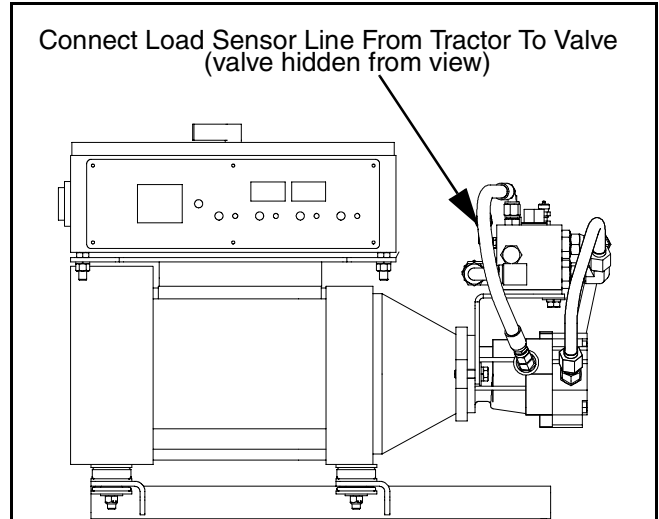

Figure 35 Tractor Generator Pump Connection on 8-Foot Screed Generator Drive Motor

Operating Pump Without Screed

When the screed is not attached to the tractor, the load sensor line is connected to route hydraulic fluid back to the pump. Attach the line it to the 1/4" nipple on the rear of the tractor (Figure 36).

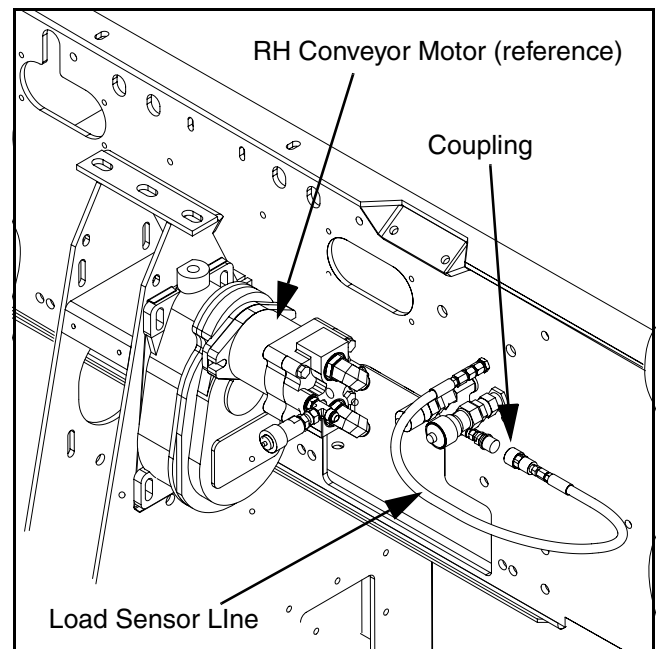

Figure 36 Generator Pump Connections for Detached Screed

VersaScreed 8 Generator Pump Setup

VersaScreed 8 Generator Pump Setup

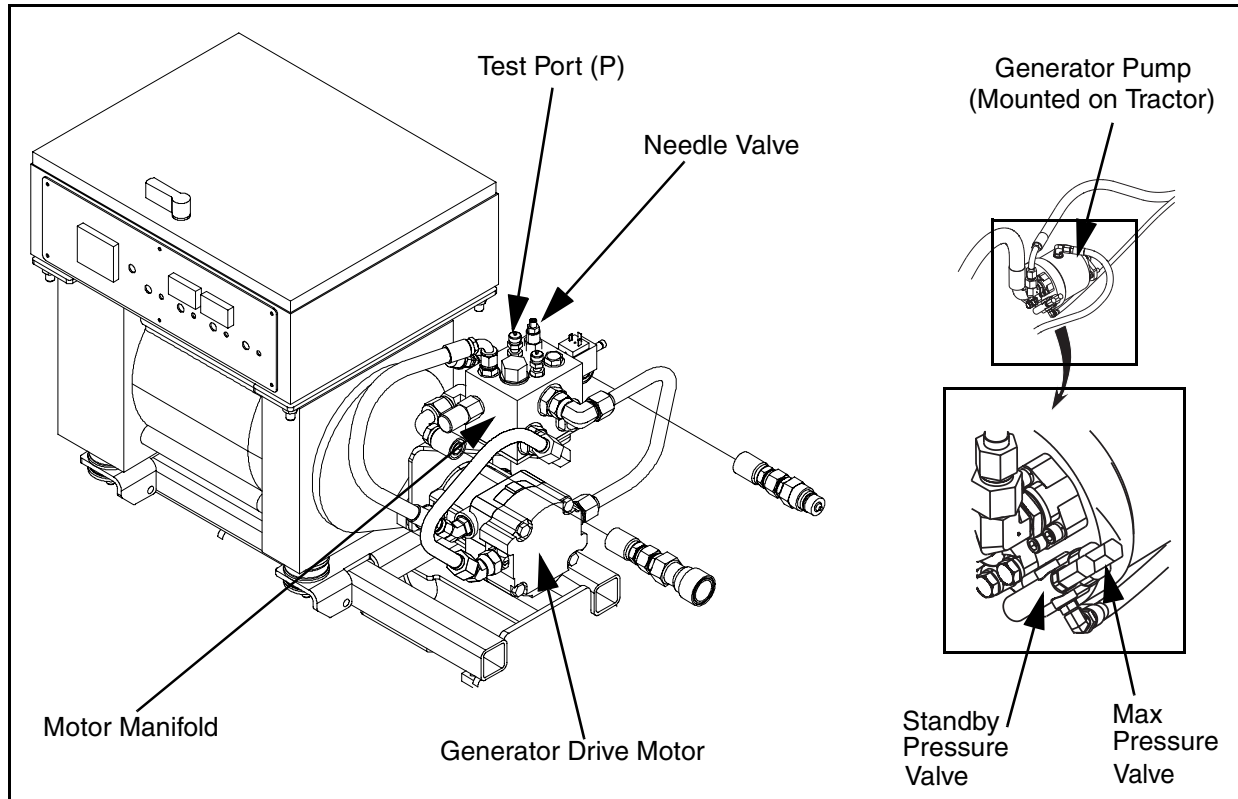

Figure 37 Generator Hydraulic Pump Assembly - VersaScreed 8

To properly operate the screed electric heating units, it is necessary to set up the screed generator pump circuit.

This hydraulic pump circuit has three valves which require adjustment: the needle valve (located on the drive motor manifold), the pump standby pressure adjustment screw and the maximum pressure valves, both located on the pump (Figure 38).

Start-up After Initial Installation of Pump

- 1) Fill pump housing with clean oil. Do this through the case drain port on the pump housing.

- 2) Loosen needle valve jam nut on screed generator drive motor manifold.
- 3) Turn screw clockwise until it bottoms to fully close valve.
- 4) Start engine and run at idle.
- 5) Turn generator switch on and let run with engine at idle approximately one (1) minute to prime pump and purge air from lines. Generator should turn at a low speed.

CAUTION

Do not apply electrical load to generator.



VersaScreed 8 Generator Pump Setup

- 6) Turn generator switch off.
- 7) Shut off engine.

Set Pump Max Pressure

- 1) Start engine and run at 1400 rpm.

NOTICE

Make sure generator switch is turned OFF.

- 2) Install 6000 psi gauge on test port (P) of generator drive motor manifold. (Figure 37)
- 3) Remove cap from standby pressure adjustment screw and loosen jam nut.
- 4) Turn standby pressure adjustment screw clockwise until it bottoms to fully seat valve.
- 5) Note gauge pressure. Pressure will be approximately 500 - 2500 psi.
- 6) Remove cap from max pressure adjustment screw and loosen jam nut.
- 7) Turn max pressure adjustment screw clockwise until gauge reads 4000 psi.
- 8) Tighten jam nut on max pressure adjustment screw and reinstall cap.

Set Pump Standby Pressure

- 1) With engine still running at 1400 rpm as described above, turn standby pressure adjustment screw counter-clockwise until gauge reads approximately 400 psi.

NOTICE

Make sure generator switch is turned OFF.

- 2) Shut off engine.
- 3) Remove 6000 psi gauge and install 1000 psi gauge.
- 4) Re-start engine and run at 1400 rpm.
- 5) Re-check pressure to make sure standby pressure reads 400 psi. Adjust if necessary.
- 6) Tighten jam nut on standby pressure adjustment screw and reinstall cap.
- 7) Shut off engine.

VersaScreed 10 Generator Pump Setup

VersaScreed 10 Generator Pump Setup

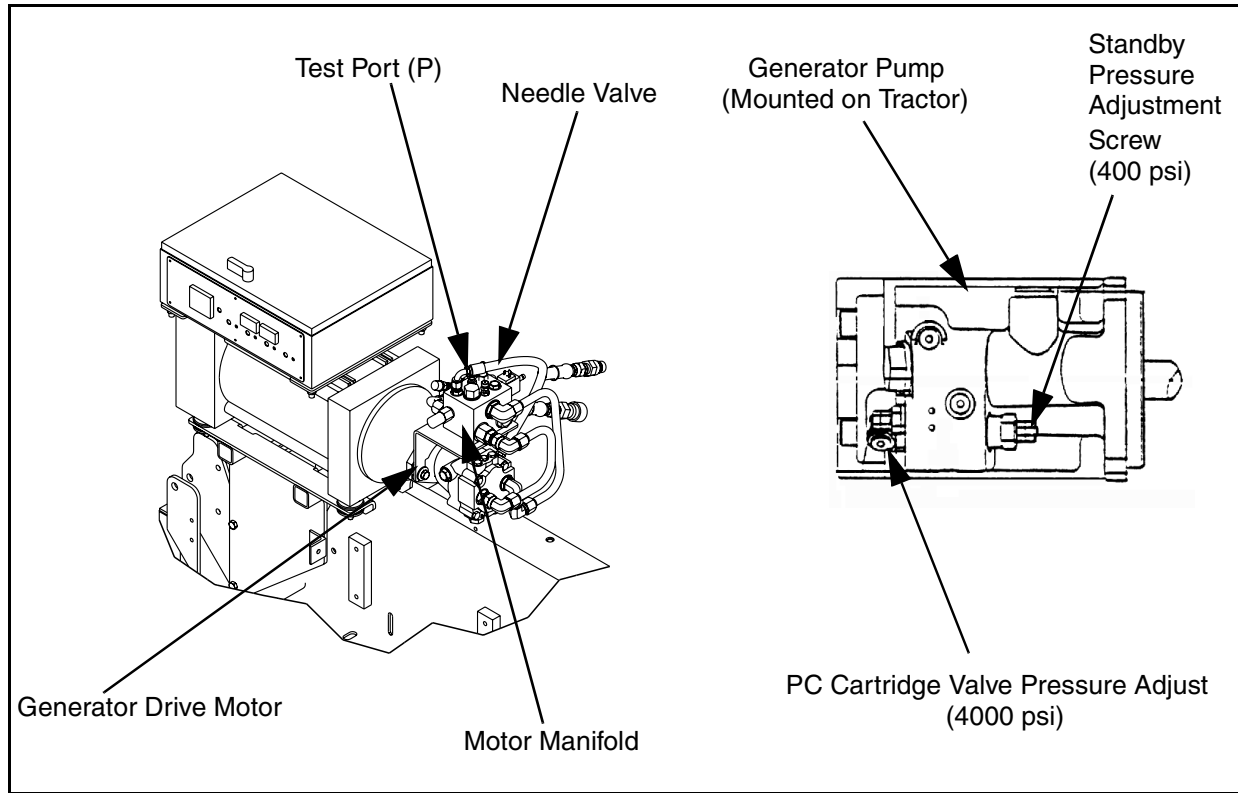

Figure 38 Generator Hydraulic Pump Assembly - VersaScreed 10

To properly operate the screed electric heating units, it is necessary to set up the screed generator pump circuit.

This hydraulic pump circuit has three valves which require adjustment: the needle valve (located on the drive motor manifold), the pump standby pressure adjustment screw and the maximum pressure valves, both located on the pump (Figure 38).

Start-up After Initial Installation of Pump

- 1) Fill pump housing with clean oil. Do this through the case drain port on the pump housing.
- 2) Loosen needle valve jam nut on screed generator drive motor manifold.

- 3) Turn screw clockwise until it bottoms to fully close valve.
- 4) Start engine and run at idle.
- 5) Turn generator switch on and let run with engine at idle approximately one (1) minute to prime pump and purge air from lines. Generator should turn at a low speed.

CAUTION

Do not apply electrical load to generator.

- 6) Turn generator switch off.
- 7) Shut off engine.

VersaScreed 10 Generator Pump Setup

Set Pump Max Pressure

NOTICE

Make sure generator switch is turned OFF or the screed is disconnected from the tractor.

- 1) Install 6000 psi gauge on test port (P) of generator drive motor manifold (Figure 38).
- 2) Remove load sensor line from X port on pump. (Figure 39).

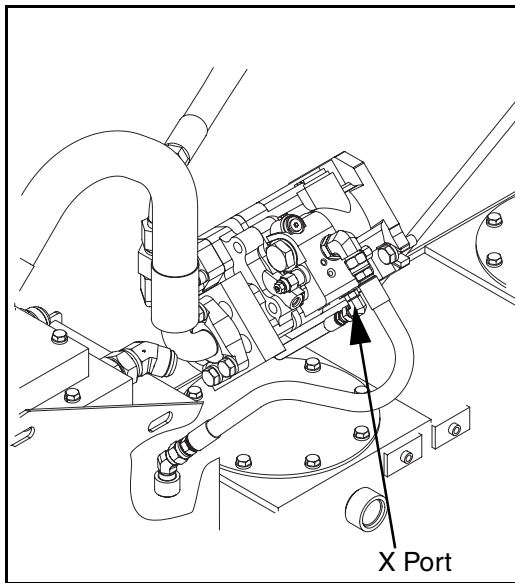

Figure 39 X Port - Tractor Generator Pump

- 3) Add a jumper hose between ports X and M2 on pump (Figure 40).
- 4) Start engine and run at 1400 rpm.
- 5) Loosen the jam nut on the max pressure adjustment screw.

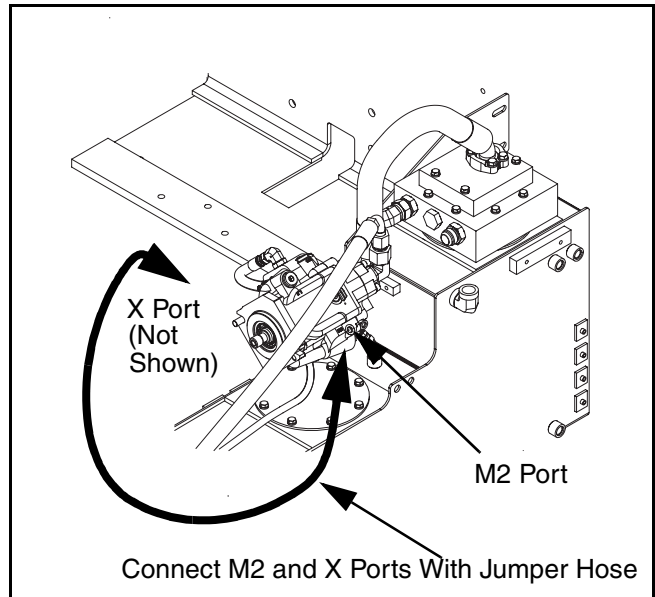

Figure 40 M2 Port - Tractor Generator Pump

- 6) Turn max pressure adjustment screw clockwise until gauge reads 4000 psi.
- 7) Tighten jam nut on max pressure adjustment screw.
- 8) Shut off engine.
- 9) Remove jumper hose and reconnect load sensor line to the X port on pump.

Set Pump Standby Pressure

- 1) Start engine and run at 1400 rpm as described above. Turn standby pressure adjustment screw counter-clockwise until gauge reads approximately 400 psi.

NOTICE

Make sure generator switch is turned OFF.

Set Generator Motor Speed (Frequency)

- 2) Shut off engine.
- 3) Remove 6000 psi gauge and install 1000 psi gauge.
- 4) Re-start engine and run at 1400 rpm.
- 5) Re-check pressure to make sure standby pressure reads 400 psi. Adjust if necessary.
- 6) Tighten jam nut on standby pressure adjustment screw and reinstall cap.
- 7) Shut off engine.

Set Generator Motor Speed (Frequency)

- 1) Install a frequency (Hz) test meter into the 120-volt outlet on the generator control box (Figure 41).
- 2) Start engine and run at 1400 rpm.
- 3) Turn generator switch on.
- 4) Turn needle valve screw counter-clockwise until test meter reads 62 Hz.
- 5) Tighten jam nut on needle valve.
- 6) Shut off engine.

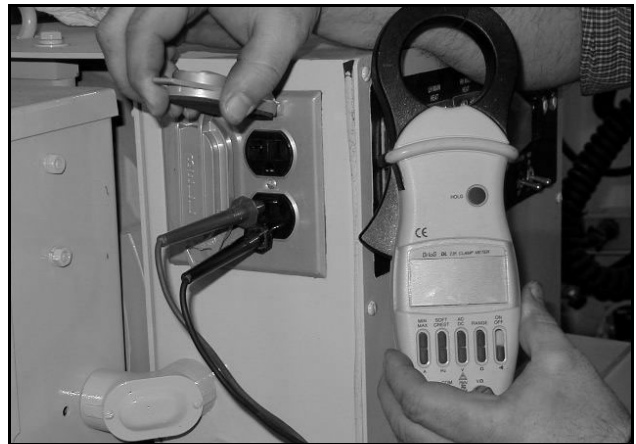

Figure 41 Setting Generator Frequency

The Screed generator pump and hydraulics are now ready to be put into operation.



TEREX

Roadbuilding

Set Generator Motor Speed (Frequency)

This Page Intentionally Left Blank