



BRUSH BANDIT

**BUILT WITH QUALITY
AND DESIGN FIRST**

ATTENTION:

Depending on what replacement parts you are ordering, we will need the following information:

CHIPPER COMPONENTS

Serial Number
Model Number of Chipper

ENGINE COMPONENTS

Brand
Engine Serial Number
Engine Spec. Number

CLUTCH COMPONENTS

Brand
Serial Number
Assembly of Clutch

BRUSH CHIPPER MODELS 1290XP/1590 OPERATING & PARTS MANUAL

Model No: _____

Serial No: _____

DEALER:

Name: _____

Address: _____

City/State: _____

Phone No: _____

Delivery Date: _____

Engine Make: _____

Serial No: _____

Clutch Make: _____

Model: _____ S/N _____



Copyright 12/07

MANUFACTURED BY
BANDIT INDUSTRIES, INC.
6750 Millbrook Road
REMUS, MICHIGAN, USA 49340
PHONE: (800) 952-0178 IN USA
PHONE: (989) 561-2270 OR 561-2272
FAX: (989) 561-2273 ~ SALES DEPT.
FAX: (989) 561-2962 ~ PARTS/SERVICE
E-MAIL: www.banditchippers.com

TO BE RETURNED AFTER THIRTY (30) DAYS OF OPERATION

Please return to: Customer Data Department
6750 Millbrook Road
Remus, MI 49340

PH: (800) 952-0178 in USA
PH: (989) 561-2270
FAX: (989) 561-2273
E-MAIL: www.banditchippers.com

DATE PURCHASED: _____

MODEL: _____

SERIAL NUMBER: _____

DEALER NAME: _____

EQUIPMENT QUALITY REPORT

All of the employees that build your equipment strive to manufacturer the **very best quality** product on the market. We would appreciate your efforts in letting us know how we are doing.

We would like you to operate your machine for thirty (30) days and then fill out this questionnaire and mail it to us. This will help us to keep producing a good product and improving our products through your recommendations.

- 1. Did your machine perform to your expectations? _____
- 2. Was the machine delivered on schedule? _____
- 3. Was the paint color and finish to your satisfaction? _____
- 4. Was machine equipment as ordered? _____
- 5. Did all welds appear to be of high quality? _____
- 6. Was the overall machine to your liking? _____
- 7. What problems have you experienced? _____
- 8. Have any components regularly loosened that caused problems? _____
- 9. Does the hydraulic system seem to have adequate power for feeding wood into the machine? _____
- 10. Is the machine manufactured to accommodate service in an adequate manner? If not, please explain:

- 11. General comments and/or suggestions: _____

- 12. Would you like to be contacted concerning more of our equipment? _____

YOUR COMPANY: _____
NAME: _____
ADDRESS: _____
CITY: _____
STATE & ZIP: _____
PHONE: (_____) _____
E-MAIL: _____

IT IS VERY IMPORTANT THAT THIS FORM IS FILLED OUT COMPLETELY & ACCURATELY. IF WE CANNOT READ THE PURCHASER'S INFORMATION OR IT IS INCORRECT, OUR CUSTOMER LIST WILL NOT BE ACCURATE.

IMPORTANT - THIS FORM MUST BE RETURNED TO THE CUSTOMER DATA DEPARTMENT WITHIN TEN (10) DAYS IN ORDER TO VALIDATE WARRANTY

Customer Data Department
6750 Millbrook Road
Remus, MI, USA 49340
Phone: (800) 952-0178 in USA
Phone: (989) 561-2270
Fax: (989) 561-2273
E-mail: www.banditchippers.com

WARRANTY VALIDATION FORM
(HAND FED CHIPPER)

PURCHASER / OWNER INFORMATION:

Company Name _____ Contact Name _____
Mailing/Street Address _____ City _____
State _____ Zip Code _____ Country _____ Telephone Number (____) _____
E-mail _____ Machine Model No. _____ Date Put Into Service _____
Machine Serial No. _____ Machine Work Order No. _____ Machine Hours _____
Engine Make _____ Engine Serial No. _____ Machine Color _____

DEALER / SELLER INFORMATION:

Dealer/Seller Name _____ Contact Name _____
Mailing/Street Address _____ City _____
State _____ Zip Code _____ Country _____ Telephone Number (____) _____

- 1. _____ Customer has been instructed and understands operation and all safety aspects of operating the equipment.
2. _____ Customer has been instructed and understands that everyone within 100 feet (30 m) of machine must wear personal safety equipment (i.e. hard hat, face shield, safety glasses, gloves, ear protection, etc.)
3. _____ Customer has been instructed and understands equipment maintenance schedules, procedures, and that it is their responsibility to perform maintenance that includes periodic relief valve adjustments, retightening all fasteners as needed, periodic cleaning of flow divider, clutch and belt adjustments, etc.
4. _____ Customer has been advised and understands not to reach into the infeed hopper with hands or feet. The machine operators must always be located within easy reach of all feed control and shut down devices.
5. _____ Customer understands that the wooden push paddle must be used to push small debris into the chipper and, that they are not to reach or kick debris into the infeed hopper area of the machine.
6. _____ Customer understands the purpose of and how to operate the last chance device, and if used the machine has been operated in an unsafe manner. Customer understands to never attempt to override any safety devices or guards.
7. _____ Customer has been instructed and understands to always remove the ignition key and completely disconnect battery from cables, wait for the chipper disc/drum to come to a complete stop, and to install the disc/drum lock before performing any type of maintenance on the machine. Allow all the time necessary for the disc/drum to come to a complete stop before opening the disc/drum housing or starting any maintenance or service procedures. Customer has been shown and understands the purpose of the beltshield inspection hole and to not attempt any maintenance until belts are visually confirmed to have come to a complete stop.
8. _____ Customer has been instructed and understands: To Not operate this machine without the factory approved hood pin assembly in place and padlocked. To Not operate this machine with any type of make shift hood pin. To Not operate this machine under any circumstances with the chipper hood open or unsecured.
9. _____ Customer has reviewed and understands limited warranty, and all written and visual instructions.
10. _____ Customer has received, been advised, and understands the manuals, and the Safety/Service video supplied with the chipper. A video is supplied for equipment models as available.
11. _____ All Danger, Warning and Operational decals are properly displayed on equipment and fully understood by customer.
12. _____ Customer has been instructed, understands, and agrees that all potential operators must: See the supplied video, be instructed on all the Danger, Warning and Operational decals, read the manual and follow the procedures.
13. _____ I have been advised of all safety options.

I have inspected this equipment and find it in correct working condition. To the best of my knowledge, the customer and his/her personnel are aware of, and agree to the above procedures.

Signed: _____ Date: _____
(Dealer Representative)

The equipment has been thoroughly checked by the above named dealer representative, and I am satisfied with his/her instructions. I have also read, understand, and agree to reverse side of page.

Signed: _____ Date: _____
(Customer)

SAFETY PROCEDURES BRUSH BANDIT CHIPPERS

SAFETY ALERT SYMBOLS AND NOTATIONS

Signal Word	Likelihood of Occurrence	Degree of Potential Injury or Damage
⚠ DANGER	Will occur if warning is ignored	Severe
⚠ WARNING	Can occur if warning is ignored	Severe
⚠ CAUTION	Will or can occur if warning is ignored	Minor to Severe
NOTICE	Important, but not hazard related	Minor

THIS IS GENERAL INFORMATION REVIEW, UNDERSTAND AND FOLLOW DETAILED INFORMATION IN MANUALS AND DECALS AT ALL TIMES

⚠ DANGER

This machine is equipped with safety decals, guards and designs for your protection.

Don't ever take the machine for granted, always be cautious and careful when operating your equipment.

Read and follow all the instructions in your manual thoroughly. Your safety is dependent on your knowledge of how to operate and maintain this machine. You may obtain additional copies of this manual from your Bandit Dealer.

Before operating machine, you must have all potential operators; read and understand manuals and decals, watch the video and follow the recommendations.

Regardless of how hard a manufacturer tries to produce a safe machine, accidents still happen. Normally accidents are caused by people making mistakes. They do not read the manual, they ignore warning decals or do not use lockouts provided for their safety. This normally happens after the person has become accustomed to the machinery. In the initial start up and operation of the machinery, they are cautious, they are very careful because they do not understand the machine.

This equipment is intended for use by personnel who are experienced with similar equipment. Always operate safely. There must be at least two qualified and trained operators at the work site. They must be positioned in safe working locations, following safety procedures and instructions, and aware of each others whereabouts. There must, also, be at least two people on site during maintenance and service procedures in case an accident should occur. Never operate any machine while under the influence of drugs or alcohol.

Keep children, bystanders and animals clear of working area. Never operate equipment that is in need of repair or adjustment.

⚠ DANGER

Turn or loose clothing is more likely to get caught in moving machinery parts or tree branches. Keep such items as long hair, shirt sleeves, and shirt tails properly contained. Avoid wearing necklaces, rings, watches, and especially neckties while operating this machinery. Make sure the machine is in excellent condition, and all the guards are in place, tight and secure.

Wear all personal protection equipment and follow all safety standards per ANSI and OSHA instructions. Examples of equipment: hard hat, face shield, safety glasses, gloves, ear protection, etc. Do not wear gauntlet or secured fit gloves. Always keep a fully charged fire extinguisher with the machine while operating or servicing the machine.

⚠ DANGER

Before starting the machine, take a minute to check a few things. The machine should be in an area restricted from people passing by. This area around the machine must be free of all objects that can obstruct your movement when working with the machine. The machine should be checked for loose tools or foreign objects, especially in the infeed hopper area. All tools not in use should be secured in a tool box.

⚠ DANGER

Before attempting any type of maintenance disengage clutch, turn off engine, wait for the chipper disc/drum to come to a complete stop, install the disc/drum lock pin, disconnect battery, and make sure the ignition key is in your possession.

ALWAYS install the disc/drum lock pin to prevent inadvertent rotation. On disc chippers insert lock pin through lock pin tube on the belly band under hood rest. On drum chippers insert lock pin through lock pin tube on side of drum housing.

Simply slide the lock pin into the disc/drum lock tube. This is to ensure that the chipper disc/drum cannot be started while you are working inside the machine. If for some reason the chipper disc/drum would start to turn, it would simply hit the lock pin.

⚠ WARNING

Always stand to the side of the infeed hopper when inserting material. This will allow you to turn away from the wood, and walk away, without passing through the material. Machines should be fed from curbside (right side) whenever possible. Anytime an operator is near the infeed hopper, they must be within easy reach of feed control devices.

To increase production, don't waste time watching the material being fed. Once the limbs have started into the machine, you can walk away and get more material.

Keep the feedwheel tension springs adjusted only tight enough to keep the feedwheel teeth from slipping on the material. DO NOT OVERTIGHTEN! This will overwork the hydraulic system, and make it difficult to feed larger material.

Always start the larger end (base end) of the log, tree or branch into the feedwheel(s) first.

Keep the engine R.P.M.'s at full throttle whether you are chipping brush or round wood. Lower R.P.M.'s will cause weak throwing power, and can cause plugging in the discharge.

⚠ DANGER

Always block the tires and the machine tongue whenever the machine is unhooked for operation. DO NOT rely on the tongue jack for operational stabilization.

⚠ DANGER

Never reach into the infeed hopper area of the machine, there is never any reason to. The feedwheel(s) are designed to pull trees and brush of any length into the machine. Pulling a hand, arm, foot or entire body through the machine is much easier than pulling a tree. Do not think you will be able to pull yourself free of the feedwheel(s), they will not let go. There is absolutely no reason to work inside of the infeed hopper. If the feedwheel(s) become tangled or clogged, stop the machine and wait several minutes before cleaning them out. If there are short pieces, or leaves and twigs, just leave them until feeding longer pieces. While the long pieces are feeding, simply toss the short pieces on top of them. The longer pieces will take them on into the machine.

A wooden push paddle has been provided to assist in feeding smaller material. It is the owner's and operator's responsibility to use and keep a wooden push paddle with the machine and to also secure it when transporting the machine. DO NOT use any body parts or any steel devices inside the infeed hopper area.

If there is larger diameter wood, try to feed it with smaller diameter wood. Start a small diameter limb which will partially open the feedwheel(s). Once the feedwheel(s) are partially open it is much easier to insert the larger diameter wood.

When feeding larger diameter wood, listen for the engine to possibly lug down. If it starts lugging down stop the feedwheel(s) by pushing the hydraulic control bar to off, and let the engine recover to full speed. If the machine is equipped with Autofeed and it is functioning properly, the feed system will automatically stop to let the engine recover. This will help stop the machine from plugging the discharge chute.

⚠ WARNING

Operators **must** at all times be located within easy reach of all feed control and shut-off devices when the unit is running. They must be attentive and prepared to activate the devices.

START-UP PROCEDURES

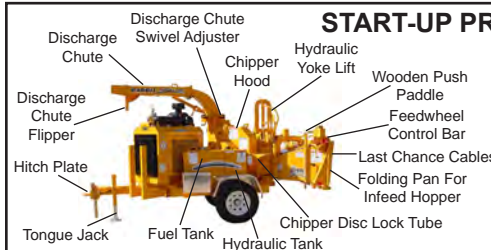

Position the control bar in the off position and start the engine and let the engine warm up at 1000 RPM's. (Follow engine manual information.) The machine may show signs of vibration until the engine can set at full throttle. The engine causes most of this vibration until it is brought up to full throttle. Engage PTO clutch, if applicable.

Push control bar forward towards the machine. This will allow the feedwheels to turn in reverse.

Allowing the feedwheels to turn in reverse will also allow for the hydraulic oil to warm up along with the engine.

Once the engine is properly warmed up, position the discharge chute to the proper position and bring the engine to full throttle. (Follow engine break-in procedures.)

Make sure to wear all personal protection equipment and follow all safety standards per ANSI and OSHA instructions. Examples of equipment: hard hat, face shield, safety glasses, gloves, ear protection, etc.

 D A N G E R

ACCIDENTS
INVOLVING
BRUSH CHIPPERS
CAN AND
SHOULD BE
PREVENTED...

Operator training and
enforcement of safety
policies are

ESSENTIAL!



DANGER

READ, UNDERSTAND AND FOLLOW ALL
SAFETY RULES AND INSTRUCTIONS

This safety booklet describes important safety features on Brush Bandit® Chippers. This booklet involves safety for your employees and the chipper. The safety features are available as update kits for older chippers and can be obtained for very little expense. If you have chippers that Do Not have any of these - Add them to your chipper now.

If you have purchased a Brush Bandit® Chipper second hand, know someone that has, or have resold a Brush Bandit® Chipper - please contact us. Please fax us at (989) 561-2273 or e-mail us at www.banditchippers.com with the chipper model number, chipper serial number, and current owners name, address, etc. We need to know them and we want them to know us. Your assistance is greatly appreciated.

Make sure your chipper operators have been properly trained, and have read, understand, and follow safety and operational procedures contained in the manuals, on the chipper itself, on decals, in this booklet, and the video. These devices can be obtained through your local Bandit® dealer. To find your closest dealer, look in the yellow pages, look on our web page (www.banditchippers.com), or call 800-952-0178 or 989-561-2270.

Most, if not all, chipper related accidents are caused by operator negligence. A lack of proper and ongoing training and lack of enforcement of safety policies significantly increase the opportunity for operator error.

Many companies involved in tree care or tree maintenance have weekly meetings to review potential hazards and discuss how accidents can be avoided. These meetings are a benefit to new inexperienced employees, and also remind experienced employees of the obvious dangers involved with tree work. Even inexperienced employees may be injured if they mistakenly believe they fully understand the machine, yet take unnecessary chances.

Industry leaders agree that safety should be at the top of everyone's priority list. Employees need constant reminders not to become over confident and not to take a casual approach to the potential hazards they encounter on a daily basis. Improperly operating a brush chipper is very dangerous. The operator must be trained and warned that amputation and death can happen unless they follow all warning instructions. They must also always be in position and ready to operate feed controls if a dangerous situation should arise.

Bandit Industries, Inc. provides numerous decals on our chippers, safety instructions in operator manuals, and videos to warn operators of hazards involving the use of the chipper. Additionally, we endeavor to provide safety features on the machines to help prevent possible accidents when operators become careless and neglectful.

The Brush Bandit® Chipper was introduced in 1983. Since then there have been several accidents in the feed wheel area involving hands, arms, feet, and legs, some of which have resulted in death. These injuries are caused by operators who improperly reach or kick into the chipper feedwheels. An operator reaches or kicks into the feedwheels when he or she feels a need to push small twigs, leaves, etc. into the feedwheels or to dislodge a piece of material in the machine. DO NOT reach or kick into the infeed hopper under any circumstances!



DANGER

NEVER REACH INTO THE INFEED HOPPER.

Operators must be trained to be constantly thinking about being in a position and ready to use the forward-off-reverse feed control bar and other controls. They should be thinking and ready to stop or reverse the feed control bar the instant they feel any pulling toward the infeed hopper or feedwheels. It is very easy to activate the control when the operator is properly positioned, to stop or reverse the feedwheels, especially if they are properly trained and paying attention.

It is difficult to activate the forward-off-reverse feed control bar if the operator is bent over, reaching into the infeed hopper of the chipper. In this position the operator is past the feed control bar, and in a very unsafe situation requiring him/her to reach back and contact the control bar to stop or reverse the



feedwheels. The operators manual, video, and decals (located several places on chipper) state; “never put feet or hands into the infeed hopper for any reason”.

If you have short pieces of wood, leaves, or twigs simply lay them on top of longer material while it is feeding into the chipper. You can also use the wooden pusher tool. Do not feed vines or vine type material into the chipper. Cut the vines into 4 to 5 foot lengths and lay them on top of longer material while it is feeding into the chipper. With the vine material at this length, stop the feedwheels and lay the 4 to 5 foot pieces in the infeed hopper, then they should be fed with the wooden pusher paddle. If you can't cut the vines to this length, don't feed it into the chipper. Never put feet or hands into the infeed hopper for any reason! Always be positioned and ready to operate control handle.

Always stand to the side of the infeed hopper when inserting material. This will allow you to turn away from the wood, and walk away, without passing through the material. Feeding from the side also positions the operator further from the feedwheels.

If you or your employees are not following these instructions, a very serious accident could occur. There is no such thing as a “minor accident” if an operator gets into the feedwheels. Severe lacerations, amputations, or even death can occur.



Do not let this happen to you or your employees. Follow correct operating instructions. There have been several accidents that involved foot amputations, leg amputations, and death as a result of operators kicking into the infeed hopper of the chipper. Brush chippers are designed to be operated with hands placing the material into the chipper - NOT FEET! If the operator kicks the material that has become lodged or is not going into the feedwheels, he or she is placing themselves in extreme danger. If the wood does free up and goes into the feedwheels, the operator can be thrown off balance. NEVER KICK OR PLACE A FOOT IN THE CHIPPER INFEED HOPPER! Use a wooden push paddle to feed light, loose, wood material such as twigs, leaves, etc. or when job is done you can shut off everything, sweep up everything, and throw it in the chip box or pile. If the wood material becomes lodged and stops feeding, back it out, and turn it to a better position or trim it with a chain saw. Then, re-feed it into the chipper. NEVER FIGHT WITH THE WOOD TO GET IT TO ENTER THE CHIPPER!

Bandit Industries, Inc. continues looking into what can be done to reduce chipper injuries. The following safety features have been developed for, and are currently being used on Brush Bandit® Chippers. They are available from your local Bandit® Dealer. Some are new and some have been presented before. We urge you to update your chippers with these devices.

To update your chippers, you must supply chipper models and serial numbers of every unit where you are installing these very important safety features. Safety devices available vary between “Hand Fed” and “Loader Fed” Chippers.



SAFETY CLOTHING AND APPAREL

It is essential that a chipper operator wears proper gloves, clothing, hard hat, face shield, hearing protection, safety glasses, etc. when operating a chipper. Don't wear gauntlet type gloves or loose improper clothing. Avoid wearing necklaces, rings, watches, and neckties while operating the equipment.

Follow the established “ANSI” and “OSHA” standards.



When you supply chipper model and serial number, these kits are available from your local Bandit® dealer.

Update Kit # UK-1007
"WELD-ON INFEED
EXTENSION PAN"

Update Kit # UK-1014
"12" EXTENSION FOR
18" PAN"

SAFETY FEATURE

WELD ON INFEED PAN EXTENSION

You must supply the chipper model number and chipper serial number when ordering, to ensure an accurate fit of the weld-on pan or pan extension. Also supply the inside width dimension of the inlet end of the infeed hopper or existing 18" deep folding infeed pan. Folding infeed pans were optional on Bandit Chippers for many years. The 18" deep infeed pan became standard equipment on Bandit hand-fed chippers in February 1994. The 30" deep folding infeed pan became standard in January 2000. If your chipper is not equipped with the pan device that extends the infeed hopper 30", one of these two weld-on kits would apply. They are simple to install. The purpose is to help locate the chipper operator further from the feedwheels; in the event he/she negligently reaches toward the feedwheels. **THERE IS NO NEED TO REACH OR KICK INSIDE THE INFEED HOPPER AREA.** It is foolish, negligent, and extremely dangerous. **DO NOT DO IT! DON'T** use your foot to push material inside the infeed hopper. **ALWAYS** be in a position and ready to quickly activate the forward-neutral-reverse feed control bar whenever you are near the infeed hopper. "Stop To Think" **BEFORE** you put your hand, foot, or body in a dangerous position - and then **DON'T DO IT!**

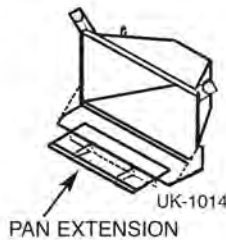
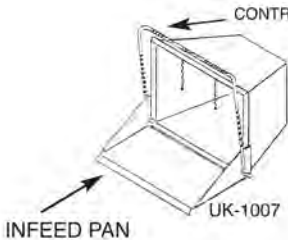

SAFETY FEATURE

WOODEN PUSH PADDLE MOUNT

Update Kit # UK-1008
"WOODEN PUSH PADDLE
AND MOUNT"

The "Wood Push Paddle and Mount" have been standard equipment on our hand fed chippers since March 21, 1994. The wooden push paddle, if used correctly, is intended to reduce the chance of a negligent operator disregarding correct procedures, and using his/her foot or hand to push small wood debris in the infeed hopper area. The wooden push paddle allows the operator to safely push materials from outside the infeed hopper.

The wooden push paddle can also be used to push wood that may be hung up in the feedwheels. If the hang up can not be dislodged by the wooden push paddle, a foot or hand won't help either. Do Not use steel or shovels or rakes. Reverse the material and trim it down, or shut down the chipper, wait as many minutes as it takes for everything to completely stop and dislodge the material using safety procedures. Have you heard reports or seen operators bending over and reaching way back into the infeed hopper, near the feedwheels? Have you seen or heard of your employees using their foot to kick or push material that is inside the infeed hopper? If either answer is yes, think how important the wooden push paddle can be to discourage reaching or kicking into the feedwheels. The wooden push paddle can be ordered through the Bandit® dealer:

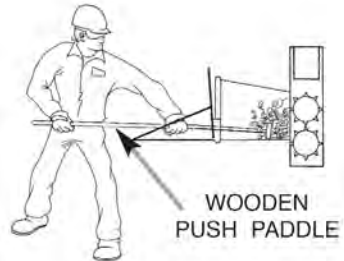

#626-0000-52
14" Wide Paddle

#980-0507-42
19" Wide Paddle

#981-1005-30
22" Wide Paddle

#980-200147
34" Wide Paddle



SAFETY FEATURE

SPRING LOCK FOR HOOD PIN

Update Kit # UK-1009
"SPRING LOCK FOR
HOOD PIN"

Since November 1996 Bandit Industries, Inc. has been installing on our hydraulic feed disc chippers a patented spring lock device for the hood pin. If properly maintained the device prevents the hood pin from being removed when the chipper disc is turning. The spring pin is positioned in front of a collar on the hood pin and when the hood pin is secured in place the hood is kept closed. While the disc is turning, the spring lock pin prevents the hood pin from being removed. The disc and disc shaft must stop turning to recess the spring lock pin and remove the hood pin. Do Not open the chipper hood with the chipper disc turning. Do Not run the chipper with the hood open. Do Not close the hood with the chipper disc turning. Do Not operate without a factory approved chipper hood pin system securely in place, and padlocked.

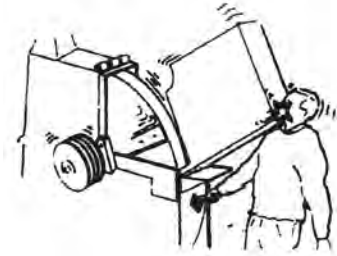

SAFETY FEATURE

CHIPPER HOOD ENGINE DISABLE PLUG

Update Kit # UK-1010
"CHIPPER HOOD ENGINE
DISABLE PLUG"

Since September 1998 mechanical feed hand fed Bandit® Chippers have been built with a plug-in device on the chipper hood that disables the engine if the hood pin, is not properly in place holding the chipper hood in the closed position. Correctly installed and maintained, the engine will not start or it will shut off if the plug-in is disconnected. The chipper hood must NEVER be opened, or pushed closed if the disc/drum is turning.

When you supply the chipper model and serial number, this kit is available through your local Bandit® dealer. You also need to supply us with the engine make and model, then we will include the electric schematic to wire the device into the engine system.

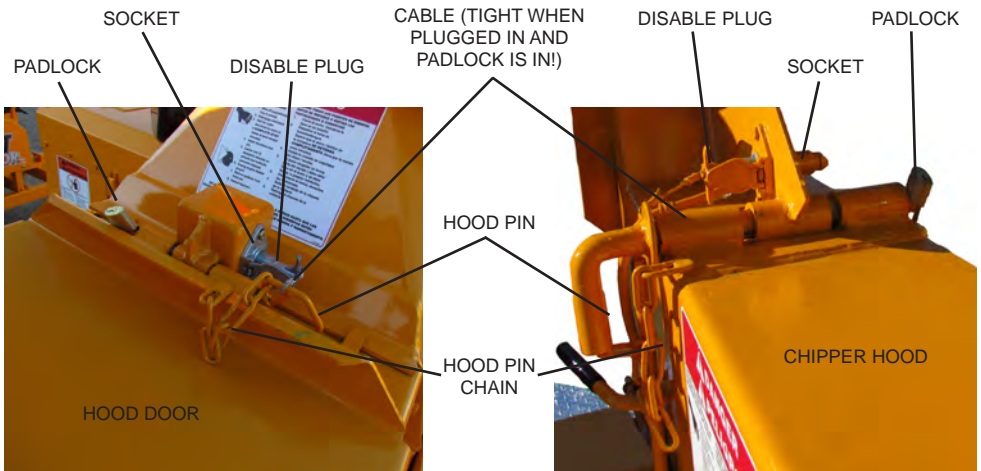

DRUM CHIPPER

DISC CHIPPER



SAFETY FEATURE

LAST CHANCE STOP

Update Kit # UK-1011
"LAST CHANCE STOP"

Have you heard reports or seen your employees bending over and reaching into the infeed hopper, near the feedwheels? Along with the wooden push paddle and the infeed hopper pan, Bandit Industries, Inc. began installing on their mechanical feed hand fed chippers the patented "Last Chance Stop" cable system. This system has been standard on Bandit® Chippers since March 1997. This device was developed to provide an emergency shut-off/reverse for the hydraulic feedwheels on most hand fed chippers, and operates without any electric parts. The system typically consists of two simple cables hanging inside the infeed hopper and in front of the feedwheels approximately halfway between the entrance of the infeed hopper and the feedwheels.

If an operator incorrectly finds themselves past the feed control bar and inside the infeed hopper, he/she has a cable to reverse/stop feedwheels and wood flow.

The "Last Chance Stop" is Not installed to encourage an operator to reach into the infeed hopper. Operators should never reach into that area with hands or feet. If your operator gets into a situation that the safety cable needs to be pulled, they have been operating the chipper in an unsafe manner contrary to all safety instructions. The system must be properly maintained and periodically checked. The "Last Chance Stop" will do nothing for the negligent operator kicking into the infeed hopper.

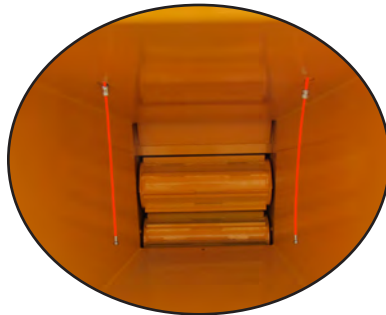

SAFETY FEATURE

HOOD LOCK PIN WITH ATTACHING CHAIN

Update Kit # UK-1012
"HOOD LOCK PIN WITH
ATTACHING CHAIN"

Brush Chippers have been involved in a number of hood related accidents over the years. Some have resulted in death! All known hood accidents happened because the factory installed solid steel pin joining the hood halves was removed and the disc was spinning when the chipper hood was opened or being closed. Do Not open the chipper hood with chipper disc/drum turning. Do Not close the hood with chipper disc/drum turning. Do Not run the chipper with the hood open. Do Not operate without the factory approved chipper hood pin system securely in place.

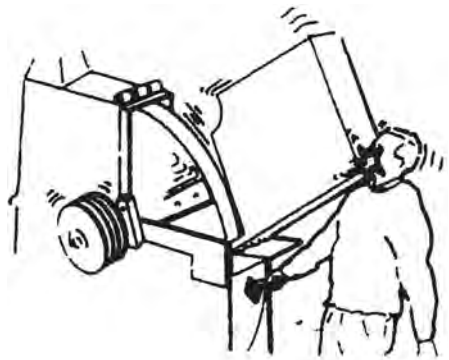

The Hood Pin has to be in place to do what it was designed to do.

Hood pins and associated parts like padlocks, engine disable plug, and spring lock for the hood pin are all available from Bandit® Dealers.

Do Not attempt to remove the hood pin or open chipper hood until the engine is shut off, you have waited as many minutes as it takes, and you can see, feel, and hear that the chipper disc/drum has stopped turning.

If the hood contacts a spinning chipper disc/drum it can suddenly fly open and severely injure or kill you.

Make-shift replacement pins don't work and are dangerous. Use the correct size factory approved pins.



SAFETY FEATURE

FEED CONTROL BAR

Brush Bandit® Chippers that are designed to be hand fed have a simple, easy to reach feed control bar located across the top and down both sides of the infeed hopper. The feed control bar operates the feedwheels forward-neutral-reverse pulling, stopping, and reversing the wood branches into the chipper. The operator must always be thinking, ready, and in position to reverse the wood flow if a dangerous situation should arise. Push the control bar away from the operator (toward chipper) to reverse wood flow on all chippers that are designed for hand feeding.

Keep the control handle serviced, and properly operational at all times. If something gets hung up in the chipper feed system, reverse it back out. Reposition the material and re-feed it back into the infeed hopper. If the wood material is too big or limby, back it out, trim it, and re-feed it in portions. **NEVER** fight or wrestle with limbs or branches! Forcing material into the chipper is an unsafe practice. When you supply the chipper model and serial number, replacement feed control bars are available at your Bandit® dealer.

FEED CONTROL BAR

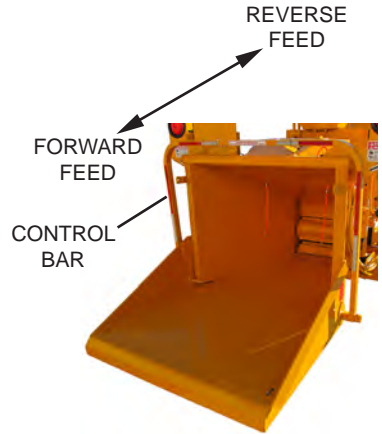

WARNING

WARNING DECALS

WARNING DECALS

There are warning decals prominently displayed on the chipper to provide a constant reminder as to how the machine should be fed, operated, and maintained. It is the owners and operators responsibility to keep all decals, especially safety related decals, clean and readable. Every person involved in the operation or service of the chipper must be familiar, understand, and follow instructions on the decals. Decals are available in a variety of languages via Bandit® dealers or factory.

Correct Installation and Care of Decals

1. You should use soap and water to keep your decals clean. Never use mineral spirits or any other abrasive cleaners.
2. Replace immediately any missing or damaged decals. The location the decal is going to be applied to must be clean and dry, and at least 40°F (5°C) before applying decal.
3. When the need arises to replace a machine component with a decal attached, be sure and replace the decal.
4. Replacement decals are available, and can be purchased from the manufacturer or your Bandit Dealer.
5. Peel back about half of the backer paper on the decal. Position it on the flat, dry, clean surface so it is smooth and secure. Peel off the remainder of the backer paper as you continue to stick the decal on the surface.
6. Rub decal from the center outward to remove air bubbles and to secure contact.
7. Combination English / Spanish decals are typically standard. Other foreign language decals are available and may be purchased. Mail translated decals required to Bandit Industries, Inc.



WARNING

OPERATOR MANUALS

OPERATOR MANUALS

Chipper operator manuals are available for all of our equipment and when machines leave the factory, they are shipped with the manuals. There is extensive safety, service, and operational information in the manuals. An operator must never be allowed to use a chipper unless he/she is completely trained, has read and understands the manual and decals, and will follow the instructions provided. The instructions are for the safety of the operator, machine, bystanders, and nearby buildings. You can obtain manuals through your Bandit® dealers.





WARNING

HOOD HINGE AND HOOD REST

The hood hinge and the hood pin are what holds the pivoting hood half in place. Both have to be properly and securely fitted and maintained. A loose or bent hinge could cause the hood to come in contact with the chipper disc/drum. IF A HOOD HINGE GETS SLOPPY OR CRACKED OR BENT, IT MUST BE REPLACED! Don't wait, replace it! The hinge is used for hood alignment and hood location security.

Don't slam the chipper hood open! It damages the hinge!

The hinge needs periodic lubrication to properly operate and to avoid excessive wear! The hinge, hood rest, and hood require scheduled inspection. If they are damaged, replace them! Use only a Bandit factory replacement part.

HOOD HINGE AND HOOD REST

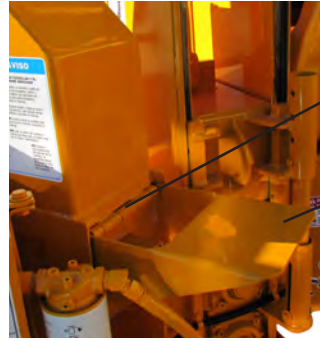

HOOD HINGE

HOOD REST



WARNING

CHIPPER KNIVES

You must use sharp, good quality chipper knives that have not been resharpened past the recommended width, per manual. Dull chipper knives are not only dangerous, but add to operating costs and slow production. Chippers Do Not feed or throw chips properly when the knives are dull. Operating with dull knives may cause the operator to push, kick, or wrestle with the wood going into the chipper which is unsafe. Dull knives make the chipper vibrate excessively, causing machine fatigue, damage, and the engine to use more fuel. Keep the knives sharp and the chipper will work smoother, feed wood easier, and make a safer operation. In the long run, sharp knives can save you money.

The chipper knives must be of good quality and the correct design for that model chipper. The knives must be properly hardened at the edge, annealed at the bolt holes, and the correct metallurgical composition. Improper knives may break and cause a dangerous and costly accident. Use only factory approved knives and mounting hardware from Bandit Industries, Inc.

Bandit Industries, Inc. offers through our dealers a unique knife sharpening device called "The Knife Saver Kit™" that within minutes can put a sharp edge back on a dulled chipper knife. The knife doesn't have to be removed from the disc or drum. The Knife Saver Kit™ sells under part number 900-9901-68.

The kit includes the sharpener, protective glove, a touch-up file, and comes in a protective case. The Knife Saver Kit™ will not restore knives that are severely nicked or damaged, but will extend knife life before needing a professional knife grind.

CHIPPER KNIVES



DANGER

REFLECTIVE STRIPED TAPE ON FEED CONTROL HANDLE

We began installing striped reflective tape on the feed control handle of our hand fed chippers. This tape is reflective, self adhesive, and has contrasting colors. The tape helps make the feed control bar stand out more and it makes the rear of the chipper more visible to a vehicle behind you while transporting the chipper. Striped tape can be obtained through your local Bandit® dealer. The striped tape can be ordered by the foot under part number 900-9901-69.

REFLECTIVE STRIPED TAPE ON FEED CONTROL HANDLE

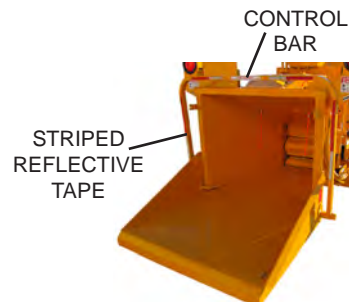

PROCEDURE FOR UNPLUGGING YOUR CHIPPER

If your chipper is plugging, it is usually caused by allowing the engine to drop below required R.P.M.'s. This can be resolved by simply shutting the feedwheel(s) off when the engine begins to lug down. Operating the engine at speeds lower than full R.P.M.'s causes your chipper to plug. **Always run the chipper at full engine speed.** If your chipper is equipped with the optional autofeed feature, make sure it is set correctly. The setting for the low R.P.M. stop must be high enough not to allow the chipper discharge to plug. Dull chipper knives also contribute to chipper plugging. Dull knives can create slivers and chunks, causing the engine to lug excessively. Both of the aforementioned conditions cause a plugging situation.

DANGER

If the chipper is properly maintained and operated correctly, the chipper should not plug. In the unlikely event that the chipper becomes plugged, do not attempt to clean out the discharge or chipper housing in the field. Take the machine to a local dealer or professional shop. If the machine is a rental, take it back to the rental company.

DANGER

If the discharge or hood need to be removed, always use some sort of mechanical device like an overhead hoist, loader, lift truck, etc. that is rated for lifting that component. Follow all OSHA instructions for lifting.

STEPS TO FOLLOW WHEN UNPLUGGING YOUR CHIPPER

1. Before attempting any type of maintenance disengage clutch, turn off engine, wait for the disc/drum to come to a complete stop, install the disc/drum lock pin, disconnect battery, and make sure the ignition key is in your possession.
2. There should, also, be at least two people on site during maintenance and service procedures in case an accident should occur.
3. Make sure the chipper disc/drum is **NOT** turning and then open the hinged portion of the chipper hood.
4. Using gloved hands and some type of raking tool, dig the chips out of the chipper housing.
5. If the discharge chute is plugged, use a raking tool to pull the majority of chips out of the open outlet end of the chute. If the discharge chute needs to be removed, use some sort of mechanical device like an overhead hoist, loader, lift truck, etc. that is rated to lift the discharge. Follow all OSHA instructions for lifting.
6. Never allow a person to turn the chipper disc/drum when someone else is working inside the chipper housing. More than likely, the chipper disc/drum will turn hard then loosen causing it to turn faster. If another person is anywhere near the chipper disc/drum, they may be injured.
7. Never turn the chipper disc/drum by hand. Always use a pry bar or wood bar. This will prevent the person turning the disc/drum from being injured should the disc/drum break loose.
8. Reinstall the discharge chute, mount securely and point it in a safe direction away from anything.
9. Never leave the chipper hood open and try to start the engine in order to engage the chipper disc/ drum to blow chips out of the housing, this is very hard on the P.T.O. of the chipper and may burn clutch plates. Also, the flying debris is very dangerous. An exposed chipper disc/drum turning very fast creates an unsafe condition. In other words, **DO NOT** start the chipper with the hood open because it is just too dangerous.
10. Once the disc/drum turns freely, close the chipper hood, insert the hood pin, install the padlock in the hood pin, reinstall the chipper hood engine disable plug, make sure the spring lock for hood pin springs back to the correct operating position on disc chippers, start engine, properly engage clutch and throttle to full speed. Insert a small branch into the feedwheel(s). If the chips discharge properly, the chipper is clear and normal operation may resume.

Training is essential! It is extremely important for everyone who operates a wood chipper to be trained. Operating instructions for the chipper are included in Bandit manuals, decals, and training videos with each chipper sold. We also highly recommend that you use the NAA chipper safety video. A copy of the video can be purchased by contacting NAA at the following address:

Tree Care Industry Association
3 Perimeter Road, Unit 1
Manchester, NH 03103
Phone: 603-314-5380
800-733-2622
Fax: 603-314-5386
E-mail: www.tcia.org

Safety training and enforcement of safety operating procedures is an important process. No device will prevent accidents when equipment is operated in an improper manner. Operators need a frequent reminder as to the proper, safe operation of any piece of equipment, especially a chipper that is designed to quickly break down material much tougher than human flesh.

Please meet with your employees and have them read this Safety Booklet. Ask them what they think about the dangers we have discussed. Ask them if they have been guilty of some of the unsafe practices addressed in this bulletin. Lecture, preach, train, discuss, and enforce safety procedures constantly!!

Maintenance of a chipper also includes maintenance of safety devices. If you loose or destroy the wooden push paddle, get another one.

Chipper safety has to be a constant and continuing effort by all involved while operating and maintaining chippers.

Bandit Industries, Inc.
6750 Millbrook Rd.
Remus, MI 49340
USA

PHONE: (800) 952-0178 in USA
PHONE: (989) 561-2270 or 561-2272
FAX: (989) 561-2273 ~ Sales Dept.
FAX: (989) 561-2962 ~ Parts/Service Dept.
E-MAIL: www.banditchippers.com

Copyright December 2011

TABLE OF CONTENTS

	PAGES
INTRODUCTION & WARRANTY	2
SERIAL NUMBER LOCATION	6
SAFETY PROCEDURES	7
EQUIPMENT SPECIFICATIONS	13
DECALS	14
AUTOFEED OPTIONS	25
CONTROLS.....	29
TRANSPORTATION PROCEDURES	35
MAINTENANCE	37
HYDRAULIC SECTION	54
CHIPPER SECTION	70
LUBRICATION & COOLANT.....	73
ELECTRICAL SECTION	74
REPLACEMENT PARTS SECTION	75
INFEED HOPPER COMPONENTS	76
CHIPPER COMPONENTS	82
CHIPPER KNIFE & HARDWARE	86
ANVIL & HARDWARE	87
DISCHARGE COMPONENTS	88
HYDRAULIC COMPONENTS	94
FRAME & ACCESSORY COMPONENTS	104
FUEL & HYDRAULIC TANK COMPONENTS	112
OPTIONAL COMPONENTS	114
SERVICE RECORD	118



NOTE - IF THE MACHINE HAS A LOADER OR TRACK UNDERCARRIAGE, CONTACT DEALER OR MANUFACTURER FOR MORE INFORMATION.

NOTE - IF THE MACHINE HAS A LOADER OR TRACK UNDERCARRIAGE, A SEPARATE (LOOSE) HYDRAULIC AND ELECTRIC SCHEMATIC IS SUPPLIED WITH THE MACHINE.

NOTE - ANY PART, PORTION, DESIGN, NUMBER, SPECIFICATION, AND/OR DIMENSION IN THIS MANUAL IS SUBJECT TO CHANGE WITHOUT NOTICE BY THE MANUFACTURER.

INTRODUCTION

The purpose of this manual is to provide the user with specifications and procedures for the operation, maintenance and repair of this BANDIT product. As with any piece of equipment, safety should always be a constant thought while the machine is being operated, serviced or stored. In order to highlight this consideration, the material which addresses safety is preceded by the following signal words:

Signal Word	Likelihood of Occurrence	Degree of Potential Injury or Damage
 DANGER	Will occur if warning is ignored	Severe
 WARNING	Can occur if warning is ignored	Severe
 CAUTION	Will or can occur if warning is ignored	Minor to Severe
NOTICE	Important, but not hazard related	Minor

The equipment is designed and manufactured in accordance with the latest product industry standards. This alone does not prevent injury. It is the operator's responsibility to use good judgement and follow the warnings and instructions as indicated in this manual.

 **WARNING**

Improper use of the product can result in severe personal injury. Personnel using the equipment must be qualified, trained and familiar with the operating procedures as defined in this manual, prior to operating the product.

 **WARNING**

It is the responsibility of the owner or employer to insure that the operator is trained and practices safe operation while using and servicing the machine. It is also the owner's responsibility to provide and follow a regularly scheduled preventative maintenance and repair program on the product, using only factory approved replacement parts. Any unapproved repairs or modifications may not only damage the machine and its performance, but could result in severe personal injury. Unapproved repairs or modifications will void warranty and eliminate manufacturer of any liability claims. Consult the equipment manufacturer!!!

Each machine is shipped with a manual, a customer's check sheet on the product, and any available parts & service manuals on component parts not produced by this manufacturer. Additional copies of these manuals and check sheets can be purchased from the manufacturer, or through the dealer. Engine parts, service and maintenance manuals **MUST** be purchased through the engine manufacturer or their dealer.

NOTE - The producer of this Bandit product reserves the right to make any modifications or revisions to the design or specifications of its machine without advance notice. The producer also reserves the right to change machine and part prices as needed without advance notice.

BANDIT INDUSTRIES, INC.

EXPLANATION OF LIMITED WARRANTY

The manufacturer will not reimburse the customer or dealer labor costs incurred for installing “bolt-on” or “slip-on” items, such as hydraulic pumps and motors, control valves, flow dividers, belts, sheaves, etc. The manufacturer will provide replacement parts to the customer for defective parts during the warranty period. **Defective parts must be returned to Bandit Industries, Inc.** It will be the customer’s responsibility to install the replacement parts unless arrangements are made with the selling dealer.

The manufacturer will not reimburse travel costs to servicing dealer unless prior approval has been obtained from the manufacturer. It is the customer’s responsibility to deliver the machine to dealer’s service facility, unless other arrangements have been agreed to between selling dealer and customer.

The manufacturer may elect, at its discretion, to reimburse reasonable labor costs to customer or dealer for major defect repairs. Diagnostic labor and overtime labor will not be covered under warranty. Prior approval must be obtained from Bandit Industries, Inc.

There are several forms that must be completely filled out and returned to us in reference to our portion of warranty. Read and understand the Bandit Limited Warranty responsibilities. Some components on your machine are covered by their respective manufacturers and cannot be handled through Bandit Industries as stated in Warranty Section of this manual.

Use this manual to help you resolve what and where your problem is, in most cases you can fix it easily. If you still have problems, work through the dealer you purchased the machine through, or contact Bandit Industries direct if needed.

Make sure the following forms are used, for us as well as you, to keep track of service and pending warranty request. It is our company policy that all parts shipped out will be invoiced until the possible warranty parts are returned with a Warranty Claim Form completed for consideration.

Make sure the Warranty Validation Form is completed and sent in to us as soon as you receive the Bandit. This will activate our warranty responsibilities.

If Warranty Validation Form is not on file, all Warranty consideration is null and void.

NOTE: Prior to delivery to final owner and during storage, this machine must be serviced and lubricated to avoid damage that will not be covered under warranty, see “Lubrication & Coolant” page.

Also, damage or premature failure of equipment components because of incorrect or incomplete service and maintenance by the equipment owner will not be covered under warranty.

All controls, safety devices, guards, and shields must be correctly operational and securely in place at all times during equipment operation.

Bandit

BANDIT INDUSTRIES INC. LIMITED WARRANTY (989) 561-2270

Bandit Industries Inc., also referred to as “Manufacturer” warrants this new product to be free of defects in workmanship and material for a period of 1 year or 2000 operating hours, whichever ever comes first.

This warranty takes effect upon delivery to the original retail purchaser. The manufacturer at its option will replace or repair at a point designated by the manufacturer, any parts which appear to have been defective in material or workmanship. The manufacturer is not responsible for labor, consequential damages, traveling or down time expenses.

This warranty and any possible liability of Bandit Industries Inc., is expressly in lieu of any other warranties, expressed or implied, including but not limited to, any implied warranty or merchantability of fitness for a particular purpose and of any noncontractual liabilities including product liabilities based upon negligence or strict liability. Bandit Industries Inc., will not be liable for consequential damages resulting from breach of warranty.

All parties involved agree that the Owner’s Sole and Exclusive Remedy against the Manufacturer, whether in contract or arising out of this warranty, instructions, representations, or defects shall only be for the replacement or repair of defective parts as provided herein. In no event or circumstances shall the Manufacturer’s liability exceed the purchase price of the machine. The buyer also agrees that no other remedy (including but not limited to consequential or incidental loss) shall be available to him or her.

It is absolutely necessary to return the Warranty Validation Form, completely and accurately filled out, and notify Bandit Industries Inc., in writing within ten (10) days from the date of purchase to validate this warranty. If Warranty Validation Form is not on file, all Warranty Consideration is NULL AND VOID.

This warranty will not apply if the Bandit Chipper is not operated with replacement parts or equipment not manufactured or recommended by Bandit Industries, Inc.

This warranty will not apply if the Bandit Chipper is not operated in a manner recommended by the manufacturer. The following examples would void the warranty:

1. The completed Warranty Validation Form is not on file.
2. The Bandit Chipper has been abused, or not serviced properly.
3. Repairs or attempted repairs made without prior written authorization.
4. Repairs made due to normal wear are not warrantable.
5. The Chipper was involved in, or damaged by an accident.
6. The Chipper was damaged from any type of foreign material.

The owner is responsible for all scheduled maintenance as explained in the Operators Manuals. Negligence of proper maintenance or any other negligence, accident or fire; nor with failure to adjust, tighten, or replace wear items included but not limited to items such as knives, knife anvil, belts, lubrication fluids, bearings, filters, hydraulic components, loose nuts or bolts, etc. may void warranty.

All components and parts being returned to Bandit Industries for warranty consideration must be complete and assembled when delivered. Hydraulic components and parts must be returned assembled with all fluid ports capped or plugged and free of foreign contamination, or warranty will not be considered.

INTRODUCTION & WARRANTY

BANDIT INDUSTRIES, INC. LIMITED WARRANTY (989) 561-2270

NOTE: This warranty applies only to new and unused equipment or parts thereof manufactured by Bandit Industries Inc. and is void if the machine is operated with replacement parts or equipment not manufactured or recommended by Bandit Industries Inc.

All other components are warranted by their respective manufacturers (i.e. engines, axles, hydraulic pumps and motors, clutches, tires, batteries, etc.) Any machines used for lease or rental purposes warranty is limited to 90 days from the first day of initial service.

CONTINENTAL U.S. INFORMATION PHONE NUMBERS FOR ACCESSORIES (NOT COVERED UNDER PRODUCT WARRANTY PROGRAM)

Briggs & Stratton Engines	1-414-259-5333	PGL Auto Clutch	1-800-551-2938
Caterpillar Engines (Thru 275Hp)	1-800-551-2938	PT Tech Clutch	1-330-414-3172
Caterpillar Engines (300Hp & Up)	1-866-228-2111	NACD, Rockford Clutch	1-800-383-9204
Continental Engines	1-800-726-8870	Twin Disc Clutch	1-440-951-5111
Cummins Engines	1-248-573-1592	Electronic Solutions	1-866-736-6839
Deutz, Lombardini Engines	1-800-445-5273	E.S.I.	1-815-985-0383
Ford, Hatz Engines	1-800-726-8870	L.O.R. MFG.	1-866-644-8622
GM, Perkins Engines	1-800-551-2938	Miratron Inc.	1-866-285-0132
Honda Engines	1-734-453-6258	Omnex Radios	1-419-294-4985
John Deere Engines	1-888-803-9175	Dexter Axles	1-574-295-7888
Kohler Engines	1-800-854-9273	Tires	1-989-463-4088
Kubota Engines	1-800-832-7670	Caterpillar Tracks	1-309-636-1100
Robin Engines	1-248-399-0002	Chermack Tracks	1-715-458-2655
Wisconsin Engines	1-800-726-8870	Petro-Canada Hydrex XV	1-888-284-4572
Interstate Batteries	1-800-331-2000		

(Phone numbers for outside the continental U.S. can be supplied from your phone directory or local Bandit dealer.)

In order to process any warranty claims, it is the owner's responsibility to report the claims promptly to the Manufacturer, or our authorized dealer from whom the equipment was purchased.

It is necessary to include the following information on any and all requests for warranty:

- 1) Warranty Claim Form, obtained from Bandit Industries or it's dealers, completely and accurately filled out.
- 2) Dealer from whom purchased.
- 3) Date of delivery.
- 4) Serial number of unit.
- 5) Model number of unit.
- 6) Engine make and serial number.
- 7) Length of time in use (hours on machine).
- 8) Date of Failure.
- 9) Nature of Failure.

Bandit Industries Inc., reserves the right to alter, improve, revise or modify any parts or products with the altered, improved, revised or modified parts or products. They also may change design, specifications, or part prices without advance notice.

Bandit Industries Inc., is NOT responsible for updating or upgrading completed machines with design changes that are made after it's production.

Bandit Industries Inc., expects the Customer/Owner to bring their machine to the Dealer/Manufacturer for Warranty Repairs. The Manufacturer DOES NOT pay Dealers or Customers for bringing their machine in for repair. Nor does the Manufacturer furnish loaner machines while the unit is being repaired.

Bandit

TYPICAL CHIPPER SERIAL NUMBER AND/OR WORK ORDER NUMBER LOCATIONS



- 1. Belt shield
- 2. W/O # on top of tongue
- 3. Side of frame (other side of frame)
- 4. Top of frame

NOTE: The engine information is located on the engine block. The clutch information is located on the clutch plate.

SAFETY PROCEDURES

⚠ DANGER

The words **⚠ Danger**, **⚠ Warning**, **⚠ Caution**, and **Notice** are used on the safety decals and throughout this manual, to make you aware of the safety procedures. These procedures are very important, read and obey them.

YOUR SAFETY IS VERY IMPORTANT TO US!

This machine is equipped with safety decals, guards and designs for your protection.

Don't ever take the machine for granted, always be cautious and careful when operating your equipment.

Read and follow all the instructions in your manual thoroughly. Your safety is dependent on your knowledge of how to operate and maintain this machine. You may obtain additional copies of this manual from your Bandit Dealer.

Before operating machine, you must have all potential operators; read and understand manuals and decals, watch video and follow the recommendations.

Regardless of how hard a manufacturer tries to produce a safe machine, accidents still happen. Normally accidents are caused by people making mistakes. They do not read the manual, they ignore warning decals or do not use lockouts provided for their safety. This normally happens after the person has become accustomed to the machinery. In the initial start up and operation of the machinery, they are cautious, they are very careful because they do not understand the machine.

This equipment is intended for use by personnel who are experienced with similar equipment. Always operate safely. It is also recommended that someone else is present while operating or servicing in case an accident should occur. Never operate any machine while under the influence of drugs or alcohol.

Keep children, bystanders and animals clear of working area. Never operate equipment that is in need of repair or adjustment.

NOTICE

Striped reflective tape has been installed on the feed control handle of the machine. This tape is reflective, self adhesive and has contrasting colors. The tape helps make the feed control handle stand out more and it makes the rear of the machine more visible to a vehicle behind the machine while transporting. Striped tape can be obtained through your local Bandit Dealer.

⚠ DANGER

Before starting the machine, take a minute to check a few things. The machine should be in an area restricted from people passing by. This area around the machine must be free of all objects that can obstruct your movement when working with the machine. The machine should be checked for loose tools or foreign objects, especially in the infeed hopper area. All tools not in use should be secured in a tool box.

⚠ WARNING

Operators **must** at all times be located within easy reach of all feed control and shut-off devices when the unit is running.

⚠ DANGER

Torn or loose clothing is more likely to get caught in moving machinery parts or tree branches. Keep such items as long hair, shirt sleeves, and shirt tails properly contained. Avoid wearing necklaces, rings, watches, and especially neckties while operating this machinery. Make sure the machine is in excellent condition, and all the guards are in place, tight and secure.

Wear all personal protection equipment and follow all safety standards per ANSI and OSHA instructions. Examples of equipment: hard hat, face shield, safety glasses, gloves, ear protection, etc. Do not wear gauntlet or secured fit gloves. Always keep a fully charged fire extinguisher with the machine while operating or servicing the machine.

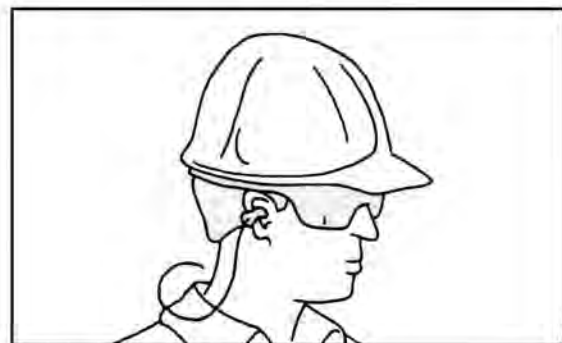

SAFETY PROCEDURES

DANGER

Always block the tires and the machine tongue whenever the machine is unhooked for operation. DO NOT rely on the tongue jack for operational stabilization.

DANGER

Pay attention to the direction of the discharge chute before chipping. Never stand in front of the chipper discharge chute. Never direct the chute towards anyone or anything that could cause an accident or problems. Always stop chipping and warn anyone that comes near the discharge area. Failure to do this could result in severe injury. Wood chips flying out of the discharge chute can be very dangerous!

DANGER

NEVER sit, stand, lay, climb or ride anywhere on this machine while it is running, operating, or in transit. You will be injured.

WARNING

It is very important after you have operated a new machine for approximately an hour to shut down the machine and recheck all nuts and bolts. It is normal for nuts and bolts to loosen once on a new piece of machinery. If you tighten them now, there is a good possibility they won't loosen again. Certain nuts and bolts should be checked periodically such as anvil and knife nuts and bolts, etc. for torque and fit.

Most of the nuts used on the machine are self locking. After a nut or bolt has been removed five times, it should be replaced to insure proper tightness. This is especially critical on the chipper knife nuts and bolts!

After the engine is started, let the chipper disc/drum turn at the lowest RPM's possible. Listen for any type of noise that is foreign. Any steel on steel noise is foreign. If you hear a noise, stop the engine, find the problem and fix it.

WARNING

DO NOT operate this machine unless all hydraulic control devices operate properly. They must function, shift and position smoothly and accurately at all times. Faulty controls can cause personal injury!

DANGER

Never reach into the infeed hopper area of the machine. There is never any reason to. The feedwheel(s) are designed to pull trees and brush of any length into the machine. Pulling a hand, arm, foot or entire body through the machine is much easier than pulling a tree. Do not think you will be able to pull yourself free of the feedwheel(s), they will not let go. There is absolutely no reason to work inside of the infeed hopper. If the feedwheel(s) become tangled or clogged, stop the machine and wait several minutes before cleaning them out. If there are short pieces, or leaves and twigs, just leave them until feeding longer pieces. While the long pieces are feeding, simply toss the short pieces on top of them. The longer pieces will take them on into the machine.

A wooden push paddle has been provided to assist in feeding smaller material. It is the owner's and operator's responsibility to use and keep a wooden push paddle with the machine and to also secure it when transporting the machine. DO NOT use any body parts or any steel devices inside the infeed hopper area.

If there is larger diameter wood, try to feed it with smaller diameter wood. Start a small diameter limb which will partially open the feedwheel(s). Once the feedwheel(s) are partially open it is much easier to insert the larger diameter wood.

When feeding larger diameter wood, listen for the engine to possibly lug down. If it starts lugging down stop the feedwheel(s) by pushing the hydraulic control bar to off, and let the engine recover to full speed. If the machine is equipped with Autofeed and is functioning properly, the feed system will automatically stop to let the engine recover. This will help stop the machine from plugging the discharge chute.

NOTICE

Do not attempt to start the engine or engage the engine PTO (power-take-off) system on this machine if the chipper disc/drum is jammed or frozen in place. If you do, you will damage or ruin the drive belts and/or the PTO which will not be covered under warranty and will cost you down time and money.

SAFETY PROCEDURES

DANGER

DO NOT feed vines or vine-like material! DO NOT pile vines or vine-like material in front of the infeed hopper which may cause you to trip or fall! DO NOT allow vines or limbs to become entangled with you or your clothing! DO cut vine-like material into 4 to 5 foot (1.2 to 1.5 meter) length's, away from the chipper area! DO stop the feed system before feeding the cut vine-like material into the infeed hopper! DO use a wooden pusher paddle when feeding the cut vines into the feedwheel(s)! ALWAYS be in position and prepared to activate the feed control handle!

DANGER

DO NOT operate this machine indoors! Exhaust fumes can be fatal. Never refuel while the machine is running. Never refuel in the shop or building. Always refuel in a well ventilated area, away from sparks or open flames, DO NOT SMOKE. Extinguish all smoking materials. Wipe up all spilled fuel before restarting the engine. Do not fill above 1/2" (12.7 mm) from top of tank.

To obtain the most from your machine, for the least amount of cost, it is a good practice to set up and follow a scheduled preventative maintenance program. It will eliminate many possible problems and down time.

WARNING

Never use jumper cables during freezing temperatures. Tow the machine inside and allow the battery time to warm up. If the machine must be started outside, inspect the battery acid for ice formation. Explosion will occur with a frozen battery. Never use jumper cables in a confined or unventilated area. Battery acid fumes are explosive. Never expose an open flame or spark near the battery.

DANGER

Before using the top feedwheel jack, if equipped, remove the yoke springs. Install the disc/drum lock pin in the mount tube before using hand jack to raise top feedwheel. Hand jack is only provided as a means of lifting the top feedwheel, not holding it up for service.

CALIFORNIA

Proposition 65 Warning

Diesel engine exhaust and some of its constituents are known to the State of California to cause cancer, birth defects, and other reproductive harm.

DANGER

Never feed any materials that might contain wires, stones, nails, metal objects, or any foreign object which may damage the knives and become dangerous projectiles.

DANGER

Before attempting any type of maintenance disengage clutch, turn off engine, wait for the chipper disc/drum to come to a complete stop, install the disc/drum lock pin, disconnect battery, and make sure the ignition key is in your possession.

ALWAYS install the disc/drum lock pin to prevent inadvertent rotation. On disc chippers insert lock pin through lock pin tube on the belly band under hood rest. On drum chippers insert lock pin through lock pin tube on side of drum housing.

Simply slide the lock pin into the disc/drum lock tube. This is to insure that the chipper disc/drum cannot be started while you are working inside the machine. If for some reason the chipper disc/drum would start to turn, it would simply hit the lock pin.

DANGER

DO NOT remove the hood pin until the chipper disc/drum has come to a complete stop. The chipper disc/drum will coast for several minutes after the engine is shut down. Always wait at least several minutes.

DO NOT operate this machine without the Hood Pin in place. Do not operate the machine with any type of makeshift hood pin or an improperly installed hood pin! The Hood Pin MUST be padlocked.

DO NOT operate the machine with the chipper hood open under any circumstances.

DANGER

The patented "Last Chance Stop" is a means of stopping/reversing the feedwheels if a negligent operator does not follow the safety rules and finds themselves in trouble! DO NOT RELY ON THE "LAST CHANCE STOP" TO DISOBEY THE OPERATOR RULES! The "Last Chance Stop" does nothing for the foolish operator who kicks into the infeed hopper area.

With engine shut off and all moving parts stopped, DAILY pull last chance cables to ensure they freely disengage and reverse feed wheel hydraulic valve.

Bandit

SAFETY PROCEDURES

⚠ WARNING

The machine was built with a chipper hood engine disable plug which disables the engine if it is not installed properly with the hood pin holding the chipper hood in the closed position. Correctly installed and maintained, the engine will not start or it will shut off if the chipper hood engine disable plug is disconnected. The chipper hood must NEVER be opened, or pushed closed if the chipper disc/drum is turning.

⚠ DANGER

DO NOT slam the chipper hood to the open position. This will cause damage to the hinge. If your hinge has become damaged by slamming the hood to the open position, Replace The Hinge Immediately! If the hinge has become damaged it will cause misalignment of the hood, the chipper disc/drum may then hit the hood and cause a serious accident! Lubricate the hood hinge daily.

⚠ DANGER

Do not work inside the mouth of the chipper or around the feedwheel(s), until you have installed the yoke lock pin completely and securely to help keep the top feedwheel in the raised position. Remove top wheel springs if equipped, block and chain top wheel up before doing any work inside throat.

⚠ DANGER

Do not work on the machine if the engine is running with the clutch disengaged. A clutch can self engage if either the pilot or throw-out bearing happens to seize to the main output shaft.

There are various types of clutches (PTO's) available for this type of equipment. Make sure to study the original clutch manufacturer's manual that is provided with the machine and follow its instructions for operation, service, and adjustments. Some styles require clutch engagement to be maintained so that it takes a lot of force, others will require very little force, and some are push button, electric, manual lever, or hydraulic activation. Each different style clutch (PTO) is a very expensive item that will fail if not correctly maintained and adjusted. It will be quite costly if a few minutes are not taken daily, weekly, and monthly to keep the clutch serviced as required.

The operator must take care in the engagement and disengagement of the clutch, engine RPM should always be below 1000 RPM. When the engine has sufficiently warmed up, bump the clutch handle against engagement to start the chipper disc/drum turning. This will have to be repeated until the chipper disc/drum is turning at proper ratio with engine RPM. Then push the handle all the way in gear until it locks into position securely. After engagement raise engine RPM to full throttle. Engaging and disengaging the clutch at high engine RPM will quickly and excessively wear out clutch plates as well as bearings. Refer to clutch manufacturer's manual for proper service and operation.

Use Yoke Lock Pin

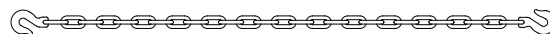
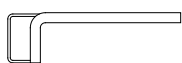

Use Chain

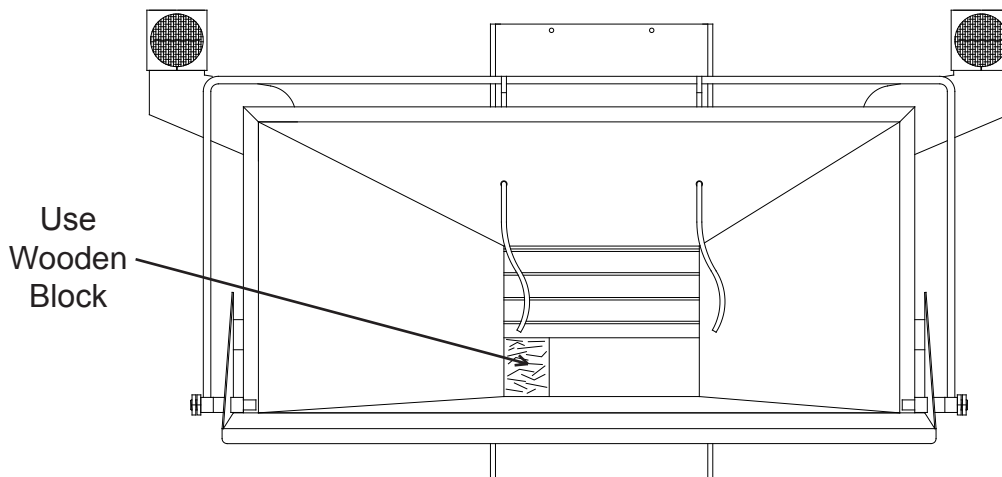

Use
Wooden
Block

SAFETY PROCEDURES

WARNING

The ANSI required control bar is designed to reverse the feedwheels when pushed. Check the direction and proper operation of the control bar before operating the chipper.

CORRECT OPERATION OF FEED CONTROL BAR

FEEDING ← OFF → PUSH TO REVERSE FEEDING



WARNING

EXPLOSION HAZARD: Ultra low sulfur diesel (ULSD) poses a greater static ignition hazard than earlier diesel formulations with higher sulfur content. Avoid death or serious injury from fire or explosion; consult with your fuel or fuel system supplier to ensure the delivery system is in compliance with fueling standards for proper grounding and bonding practices.



DANGER

Before opening or closing the feedwheel trap door: disengage clutch, turn off engine, wait for the disc/drum to come to a complete stop, install the disc/drum lock pin, disconnect battery, and make sure the ignition key is in your possession. In the event that dirty material is being run through the chipper the feedwheel trap door can be opened.

DANGER

If the discharge or hood need to be removed, always use some sort of mechanical device like an overhead hoist, loader, lift truck, etc. that is rated for lifting that component. Follow all OSHA instructions for lifting.

SAFETY PROCEDURES

WARNING

CLEAN MACHINE OF ALL DEBRIS! DO NOT leave this machine unattended until all potential fire debris is removed, no fire or smoldering exists, and hot spots are cold. The engine creates many hot spots including: exhaust manifold, exhaust, turbo (if equipped), etc. Remove all flammable debris such as wood, chips, leaves, oils, fuels, etc. from engine exhaust, engine turbo (if equipped), beside, around, and under engine, around and under tanks, inside belt shields and guards, inside battery and tool boxes, inside cabinets (if equipped), and anywhere materials collect. ALWAYS keep several type A:B:C fire extinguishers operational and on the job at all times.

WARNING

Operation of this equipment may create sparks that can start fires around dry vegetation. A spark arrester may be required. The operator should contact local fire agencies for laws or regulations relating to fire prevention requirements.

NOTICE

The Bandit has only been run for a short time to test proper hydraulic pressures, possible leaks, etc. The fuel tank will be empty. Fuel is provided through a small auxiliary tank for testing. This immensely helps maintain safety in our manufacturing facility and while shipping.

NOTICE

Expensive damage to the Bandit will occur if proper preparation is not taken before welding on the machine. Be sure to disconnect both battery cables and the engine ECM (engine control module) before welding. Follow the specific Engine MFG. instructions for proper welding and grounding procedures, before attempting to weld on the machine. If welding on the machine, do not ground the welder through the machine bearings, ground near work to be performed.

DANGER

Brush being fed into the chipper infeed hopper can snag an extended winch line. The knives on the spinning disc/drum can grab and pull in the winch line at a high rate of speed resulting in serious injury or death to workers nearby.

DANGER

The winch line is under tension at times and could suddenly release, snapping back into the operator causing serious injury or death.

DANGER

Never operate the hydraulic winch with the wood chipper detached from the towing vehicle. The load may move the wood chipper or pull the tongue off the support blocking.

DANGER

Climbers' ropes and other lines present at the work site can become entangled in brush being fed into the chipper. The knives on the spinning disc/drum can grab and pull in ropes at a high rate of speed resulting in serious injury or death to workers nearby.

DANGER

Most winch lines contain a metal hook at the end. If the metal hook enters the infeed hopper, it could be ejected out of the discharge chute at a high rate of speed causing serious injury or death.

DANGER

Make sure there is outbound tension on the winch line whenever the winch line is being powered out. Using the hydraulic control to power out the winch line rather than free spool the line out could result in the line becoming tangled around the spool and wind inward when the hydraulic lever is in the unwind position. If a worker is holding the winch line when this happens a potential nip point is created between the cable housing and hook and also the winch line and material.

DANGER

Never reach into the winch or winch roller area.

OPERATING & PARTS MANUAL SUPPLEMENT

KEEP WITH YOUR OPERATING & PARTS MANUAL

PROPER MAINTENANCE AND USE OF BOTTOM CLEAN-OUT DOOR

DANGER

There is never any reason to open the bottom clean-out door while the chipper is in operation. Opening and closing the bottom clean-out door should always be done after the chipper has been turned off and the feedwheels have stopped turning. The ignition key should be removed and in the operator's possession.

Never reach or kick underneath the chipper in the area of the feedwheel clean-out door. If your hand or foot comes into contact with the bottom feedwheel, serious injury could occur. Always turn off the chipper and make sure the feedwheels have stopped turning before performing any maintenance in the bottom clean-out door.

There is never any need to remove debris that collects underneath the chipper while the chipper is in operation. Make sure the chipper engine is off and the feedwheels have stopped turning before cleaning any debris from underneath the chipper, or simply move the chipper to assist with cleaning debris from underneath it.

The bottom clean-out door is located directly underneath the feedwheels. It is hinged to the chipper and can be secured in a closed position with spring-loaded pins. When the door is in the closed position, access is restricted to the bottom feedwheel from underneath the chipper. When in the closed position, the door keeps debris from piling on the ground. The door can be opened to perform maintenance to the bottom feedwheel or to assist with unclogging, should vine-like material become wrapped around the bottom feedwheel.

During chipping operations, the bottom clean-out door should be closed. It is intended to be open **ONLY** when materials that need to be placed into the chipper contain muddy gravel or rocks. If possible you should try to remove all gravel, mud, and rocks from the brush before feeding it into the chipper. By opening the bottom clean-out door, mud, and rocks are allowed to drop down onto the surface below, preventing damage to the knives and discharge chute which can cause damage to the chipper, as well as serious risk of injury. Stray rocks and gravel may damage or break the knives. Rocks and broken knives will be propelled out through the discharge chute, which could cause injury to anyone in the vicinity.

Never transport the chipper with the bottom clean-out door in the open position because it subjects the door to physical abuse and damage during transportation. This can damage the hinge and prevent the door from being properly closed during operation.

Once the bottom clean-out door has been opened to perform maintenance or prevent debris from damaging the chipper, the door should always be closed before continuing operations.

SAFETY PROCEDURES FOR OPERATING OPTIONAL HYDRAULIC WINCH

This Notice describes important safety information for all Brush Bandit wood chipper owners and operators. The information below is meant to provide you with notice of a potentially dangerous situation that can and should be avoided.

Everyone working around wood chippers should be well-trained to understand that ropes and cables commonly used at the job site can inadvertently be pulled into the chipper while feeding brush. This includes the cable on the optional hydraulic winch attached to the top of the infeed hopper. When the winch line is extended, the opportunity exists for brush or workers to become entangled in the winch line. Never place yourself between the brush and winch line. Feeding brush with the winch line extended or when other ropes are in the area of the infeed hopper can result in the line becoming entangled in the brush being fed into the chipper. If this happens, the winch line or rope will be pulled into the chipper. If any rope or cable becomes caught in the spinning knives, it could be pulled into the chipper at a high rate of speed and when a worker is in its path, there is little or no opportunity to avoid it. The result is serious injury or death.

Chipper owners and operators should not feed brush into the chipper while the winch line is extended. The intended use of the winch is to assist the operator in pulling large tree limbs to the wood chipper feedwheels without having to lift and carry. Never pull out the winch line while brush or limbs are feeding into the chipper. When you are not using the winch, ensure that it is retracted and stowed so that it cannot become tangled in brush and pulled into the chipper.

Make sure there is outbound tension on the winch line whenever the winch line is being powered out. Using the hydraulic control to power out the winch line rather than free spool the line out could result in the line becoming tangled around the spool and wind inward when the hydraulic lever is in the unwind position. If a worker is holding the winch line when this happens a potential nip point is created between the cable housing and hook and also the winch line and material.

⚠ DANGER

Brush being fed into the chipper infeed hopper can snag an extended winch line. The knives on the spinning disc/drum can grab and pull in the winch line at a high rate of speed resulting in serious injury or death to workers nearby.

⚠ DANGER

Climbers' ropes and other lines present at the work site can become entangled in brush being fed into the chipper. The knives on the spinning disc/drum can grab and pull in ropes at a high rate of speed resulting in serious injury or death to workers nearby.

⚠ DANGER

Never operate the hydraulic winch with the wood chipper detached from the towing vehicle. The load may move the wood chipper or pull the tongue off the support blocking.

⚠ DANGER

Never reach into the winch or winch roller area.

⚠ DANGER

Follow all winch operating procedures, if not followed severe injury or death can result.

- The intended use of the winch is to assist the operator with pulling large tree limbs to the wood chipper feedwheels without having to lift and carry.
- Pinch point hazards may develop during winching operations. The hydraulic controls are located on the side of the infeed hopper. Operating the winch is a one-man operation. Do not have one person operating the winch hydraulic control with another person operating or holding the winch line. The person holding the winch line could have his hand pinched when another person is operating the winch control.
- Winching large limbs to the wood chipper should be performed by one person.
- Stay clear when winching.
- Do not allow winch line or other ropes to be snagged and pulled into the chipper knives.
- Avoid becoming entangled in the winch line. Never place yourself between the brush and the winch line while using the winch line to pull large tree limbs toward the chipper.
- The metal hook at the end of the winch line entering the wood chipper could result in serious damage to the knives and other internal components causing the potential for injury to operators.
- When you are not using the winch, ensure that it is retracted and stowed so that it can not be pulled into the chipper.
- Never pull out the winch line while brush or limbs are feeding into the chipper.
- Never attach winch line to an installed choker if other limbs are feeding into the machine.
- Brush can snag winch line or climbers' ropes. Knives can grab and pull in line and anything attached to it at a high rate of speed.
- If you are in between the chipper and the winch line that is caught in the knives, the winch line will be pulled in at a very rapid speed and you will not have time to get out of its way. Death or serious injury may result.
- Do not overload the winch. The cable can break or the choker can come off and strike a worker.
- Be aware of the hazards of winch line breakage. Ensure that everyone remains clear of the recoil area in the event of load or cable breakage.
- Pull loads in a manner that avoids angles which could result in tipping or other unintended movement of the chipper and towing vehicle.

⚠ DANGER

Most winch lines contain a metal hook at the end. If the metal hook enters the infeed hopper, it could be ejected out of the discharge chute at a high rate of speed causing serious injury or death.

⚠ DANGER

Make sure there is outbound tension on the winch line whenever the winch line is being powered out. Using the hydraulic control to power out the winch line rather than free spool the line out could result in the line becoming tangled around the spool and wind inward when the hydraulic lever is in the unwind position. If a worker is holding the winch line when this happens a potential nip point is created between the cable housing and hook and also the winch line and material.

⚠ DANGER

The winch line is under tension at times and could suddenly release, snapping back into the operator causing serious injury or death.

SAFETY PROCEDURES

⚠ WARNING

Always stand to the side of the infeed hopper when inserting material. This will allow you to turn away from the wood, and walk away, without passing through the material. Machines should be fed from curbside (right side) whenever possible. Anytime an operator is near the infeed hopper, they must be within easy reach of feed control devices.

To increase production, don't waste time watching the material being fed. Once the limbs have started into the machine, you can walk away and get more material.

Keep the feedwheel tension springs adjusted only tight enough to keep the feedwheel teeth from slipping on the material. **DO NOT OVERTIGHTEN!** This will overwork the hydraulic system, and make it difficult to feed larger material.

Always start the larger end (base end) of the log, tree or branch into the feedwheel(s) first.

Keep the engine R.P.M.'s at full throttle whether you are chipping brush or round wood. Lower R.P.M.'s will cause weak throwing power, and can cause plugging in the discharge.

⚠ DANGER

Never turn the chipper disc/drum by hand, always carefully use a pry bar or wood bar. This will help prevent the person turning the disc/drum from being injured should the disc/drum break loose.

A sight hole in the chipper beltshield has been provided. If chipper belts are moving do not open chipper hood. Do not stick fingers in sight hole.

⚠ WARNING

It is very important after you have operated a new machine for approximately an hour to shut down the machine and recheck all hydraulic fittings. Retighten as needed.

DO NOT GO NEAR HYDRAULIC LEAKS! High pressure oil easily punctures skin causing serious injury, gangrene, or death. **DO NOT** use fingers or skin to check for leaks. Lower load or relieve hydraulic pressure before loosening fittings. Use a piece of cardboard to find leaks. Never use your bare hands.

In cold weather situations let your hydraulic system idle for approximately 15 minutes to allow the system to warm up to operating temperature.

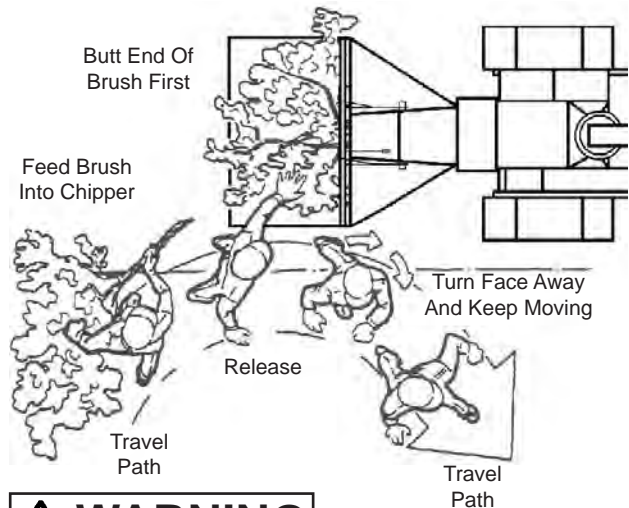

⚠ WARNING

Before you begin to transport your trailerized machine follow all of the transportation procedures on pages 35-36. Make sure that the tongue has been raised to the proper height and attach the machine securely to the towing vehicle. Once secured to vehicle, locate tongue jack and secure it in the transport position. Always hook safety chains to vehicle by crossing them under the tongue allowing enough slack to avoid binding or dragging the ground when making turns. Check brakes and highway lights make sure that they are all operating properly. Check that the plug terminal functions match the towing vehicle for proper operation. Make sure that the discharge chute is in the transport position pointed over the tongue of machine and the transport bolt is securely in its place. Be sure to check tire pressure before you begin to transport the machine. Close the folding pan, if equipped for the infeed hopper and make sure spring latches are locked into place. If machine is equipped with a vise, make sure to secure in place and clamp jaws closed. Close and secure any of the following, if equipped: tool box, battery box, engine cowl doors and side panels, radiator debris screens, inspection doors, cabinet doors, housing covers, tank caps and covers, etc.

⚠ DANGER

Chipper knives are sharp and can be dangerous. It is always necessary for your protection to be extra careful and wear leather gloves when handling knives.

⚠ DANGER

The knives must be securely fastened and torqued in position. If one comes loose or breaks during operation, someone or something may get injured.

Bandit

SAFETY PROCEDURES

IF MACHINE IS EQUIPPED WITH UNDERCARRIAGE TRACK

Machines equipped with undercarriage tracks are shipped with a manual from the track manufacturer. Refer to it for service, operation, and safety information.

⚠ WARNING

Do not attempt to operate the track machine on an ascending or descending slope of more than 25° or 46% or a side slope of more than 17° or 30%, it is Dangerous and could be Fatal. This is the maximum slope grade the machine can be operated on if the hydraulics, tracks, and engine are running at maximum performance and the tracks sustain good traction.

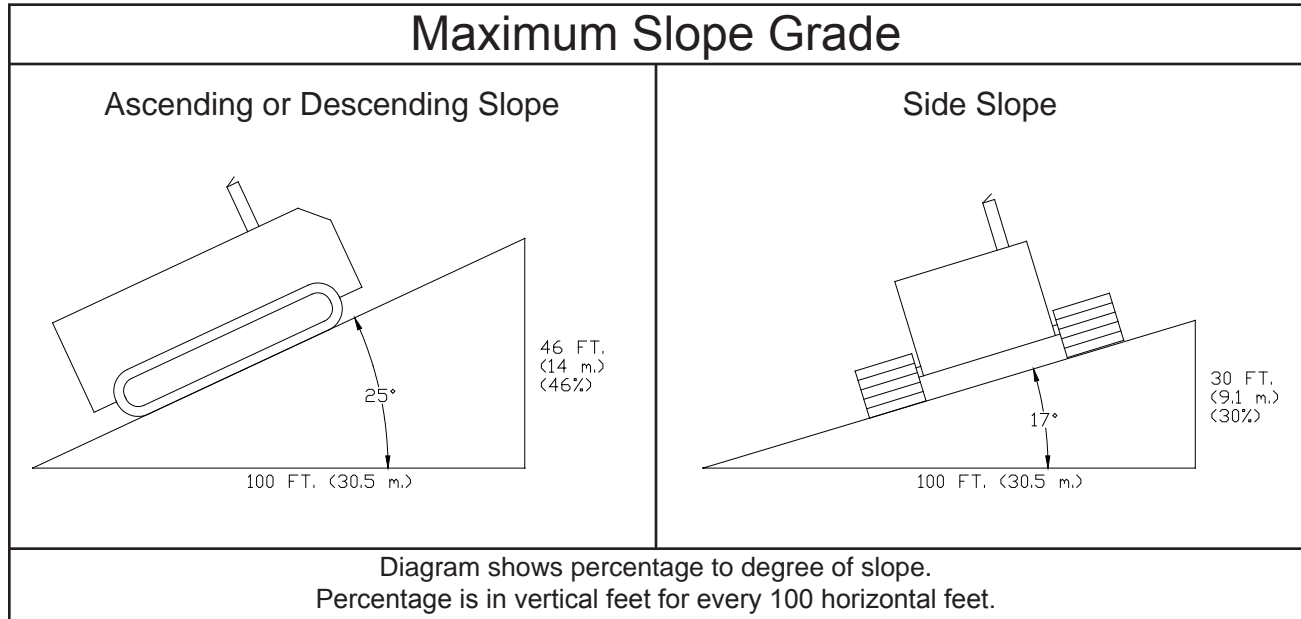

⚠ WARNING

Any increase from the specified maximum operating angles may cause loss of lubrication function and damage the engine.

⚠ DANGER

The track machine should never be parked on a slope at any time. The machine can coast or creep causing equipment and/or personal injury.

⚠ DANGER

Make sure everyone is clear of machine before moving the track machine. Stay clear of tracks when the machine is moving.

⚠ DANGER

DO NOT entangle feet or hands in undercarriage travel system.

⚠ DANGER

Use **EXTREME CAUTION** when traveling over non-level surface! This machine can tip over or tip backwards on non-level surface. You will cause engine damage, machine damage and possible personal injury!

⚠ DANGER

NEVER sit, stand, lay, climb or ride anywhere on this machine while it is running, operating, or in transit. You will be injured.

Bandit

EQUIPMENT SPECIFICATIONS

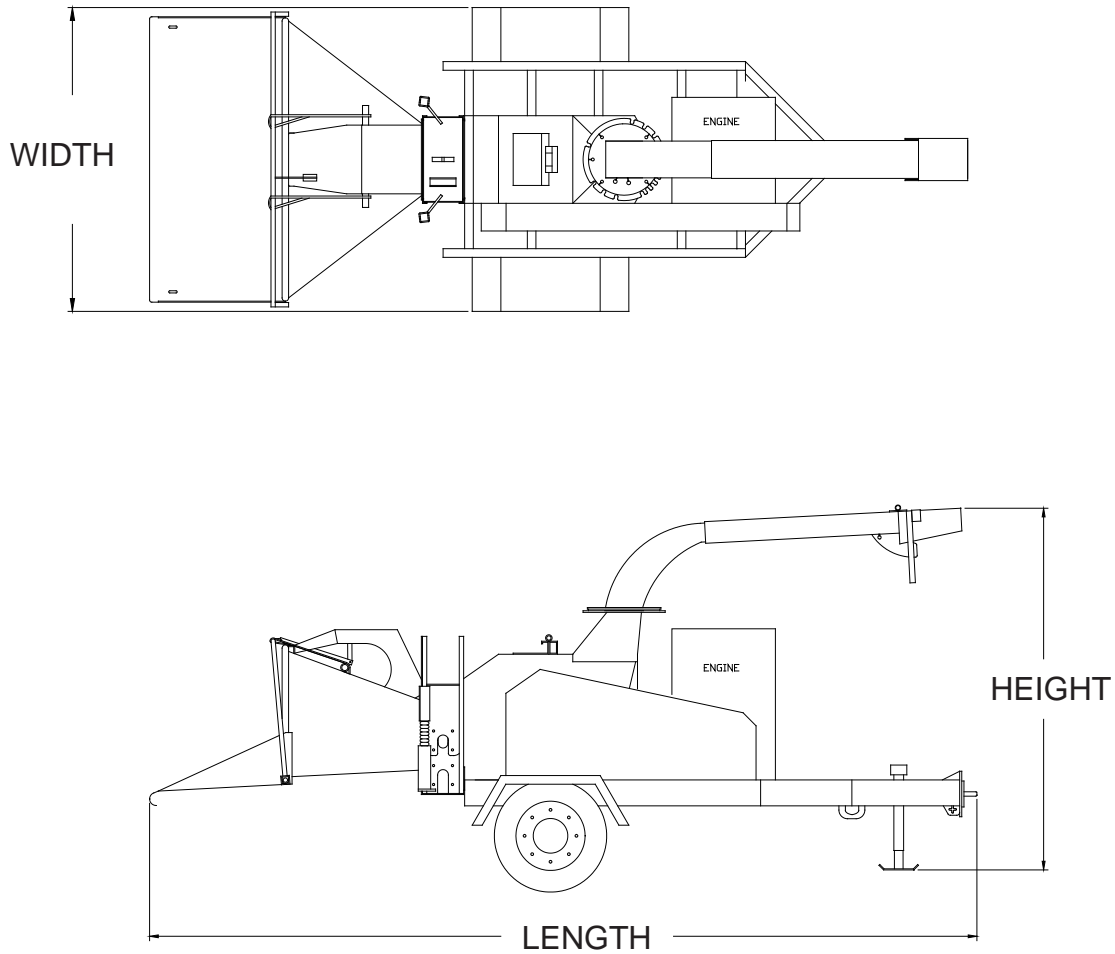

Approximate Dimensions & Weights

(Dimensions & weights will vary depending on optional equipment)

Approx. Model 1290XP: 6800 to 7500 lbs. (3084 to 3402 kg)
 Weight: Model 1590: 7000 to 7800 lbs. (3175 to 3538 kg)

(Approximate weights depending on engine and equipment options.)

Overall Model 1290XP: Height: 96" (2.4 m), Length: 208" (5.3 m), Width: 85" (2.2 m)
 Dimension: Model 1590: Height: 107" (2.7 m), Length: 199" (5.1 m), Width: 85" (2.2 m)

	<u>Model 1290XP</u>	<u>Model 1590</u>
Fuel Tank Capacity:	24 Gallons (91 Liters)	30 Gallons (114 Liters)
Hydraulic Tank Capacity:	12 Gallons (45 Liters)	12 Gallons (45 Liters)

(Approximate dimension depending on equipment options.)

DECAL LOCATIONS - MODEL 1290XP

Decal locations may vary, these are general locations.

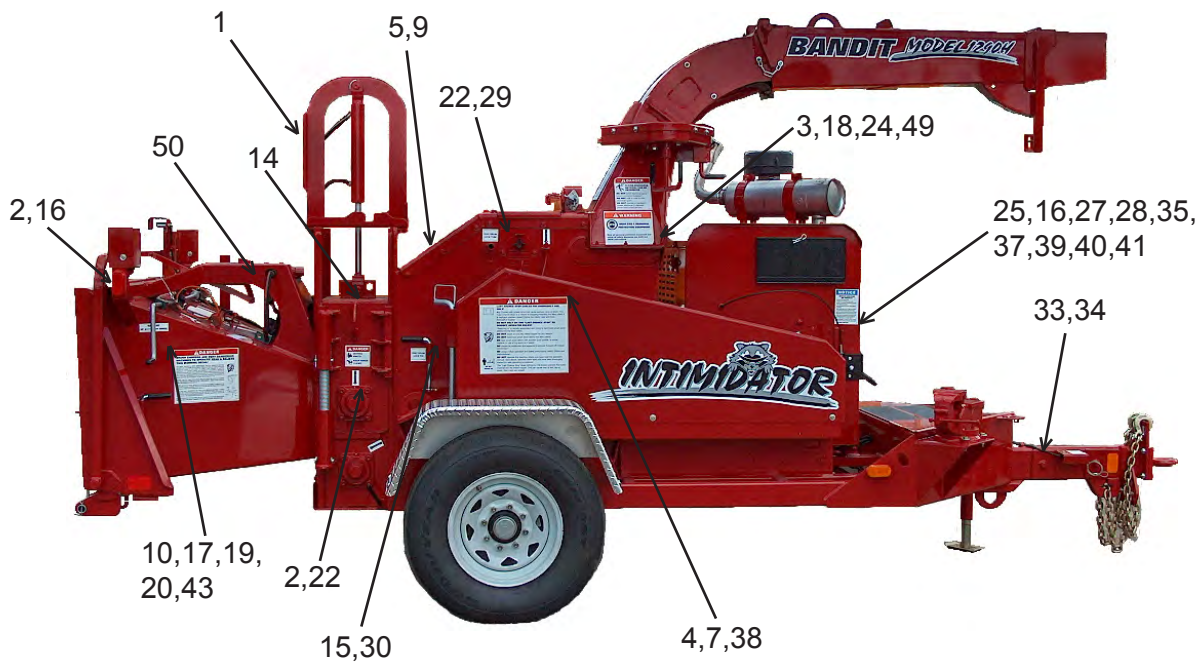
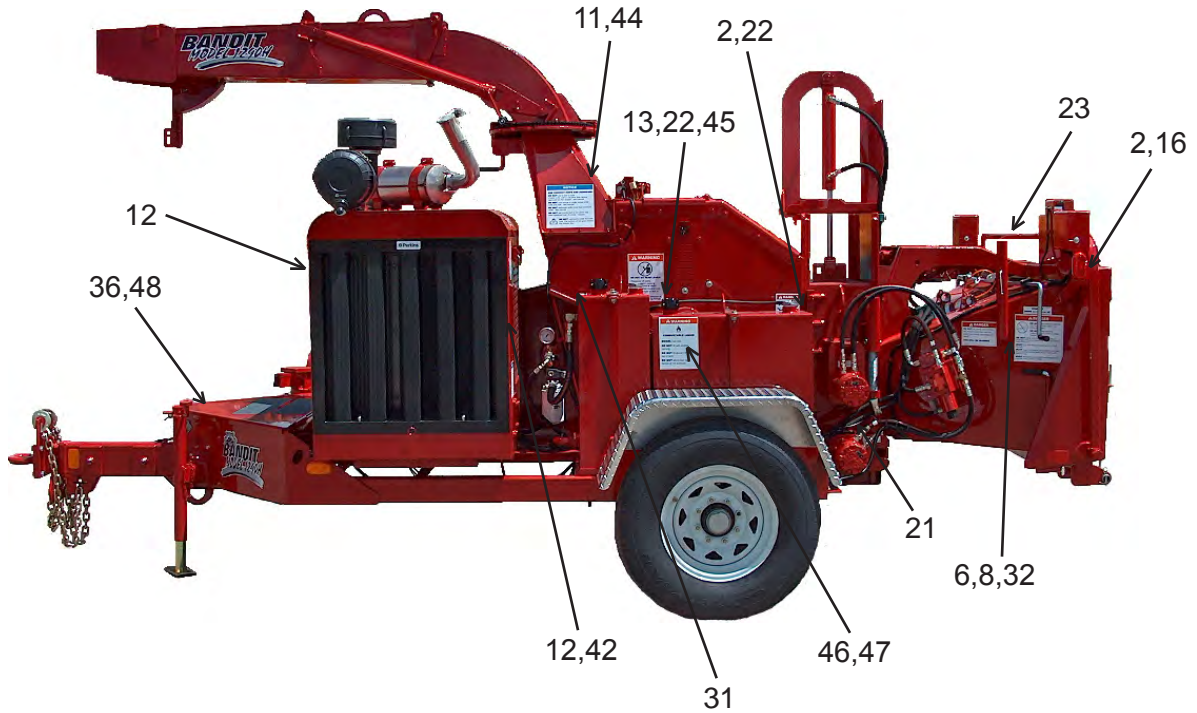

DECAL LOCATIONS - MODEL 1290XP

Modifications and/or additions of decals to this list will happen.
 Consult chipper dealer or manufacturer for most current decal package.

LOCATION	NUMBER	DESCRIPTION
1.	SPD-01	Avoid Injury Or Death...
2.	SPD-02	Moving Parts...
3.	SPD-04	Flying Discharge Material...
4.	SPD-07	Last Chance Stop Cables...
5.	SPD-09	Not Work Under Top Feed...
6.	SPD-12	Do Not Feed Vine-Like...
7.	SPD-28	Do Not Insert Fingers
8.	SPD-30	Do Not Sit, Stand, Lay, Climb...
9.	SPD-33	Do Not Work Under...
10.	SPD-34	Brush Chippers Are Very Dangerous...
11.	SPD-37	Lockout All Energy Sources...
12.	ID-42	Bandit Industries Inc...USA
13.	INST-01	Remove To Check Torque...
14.	INST-02	Yoke Lock Hole
15.	INST-03	Yoke Lock Bar
16.	INST-04	Arrow
17.	INST-05	Yoke Lift Up / Down
18.	INST-07	Discharge Swivel Right / Left
19.	INST-08	Winch Control Out / In
20.	INST-09	Selector Winch / Feed
21.	INST-11	Motor Coupler Guard...
22.	INST-12	Grease Daily (Arrow)
23.	SPINST-13	Push To Reverse
24.	INST-15	Flipper Down / Up
25.	INST-16	Grease Weekly Arrow
26.	INST-39	Oil Daily Arrow
27.	INST-44	California Proposition 65
28.	INST-46	Autofeed Basic Info...
29.	INST-48	Disc/Drum Lock Tube
30.	INST-49	Disc/Drum Lock Pin
31.	INST-53	Hydraulic Oil...Hydrex XV...
32.	INST-76	Yoke Lift Down / Up
33.	INST-90	Tongue Up / Down
34.	INST-95	Electric Plug-In Schematic
35.	INST-101	Canada Engine Decal
36.	INST-109	Basic Maintenance Check List

Note: Some decals are for optional equipment. Decal locations may vary, these are general locations. If any decals become damaged, replace immediately.

DECAL LOCATIONS - MODEL 1290XP

Decal locations may vary, these are general locations.

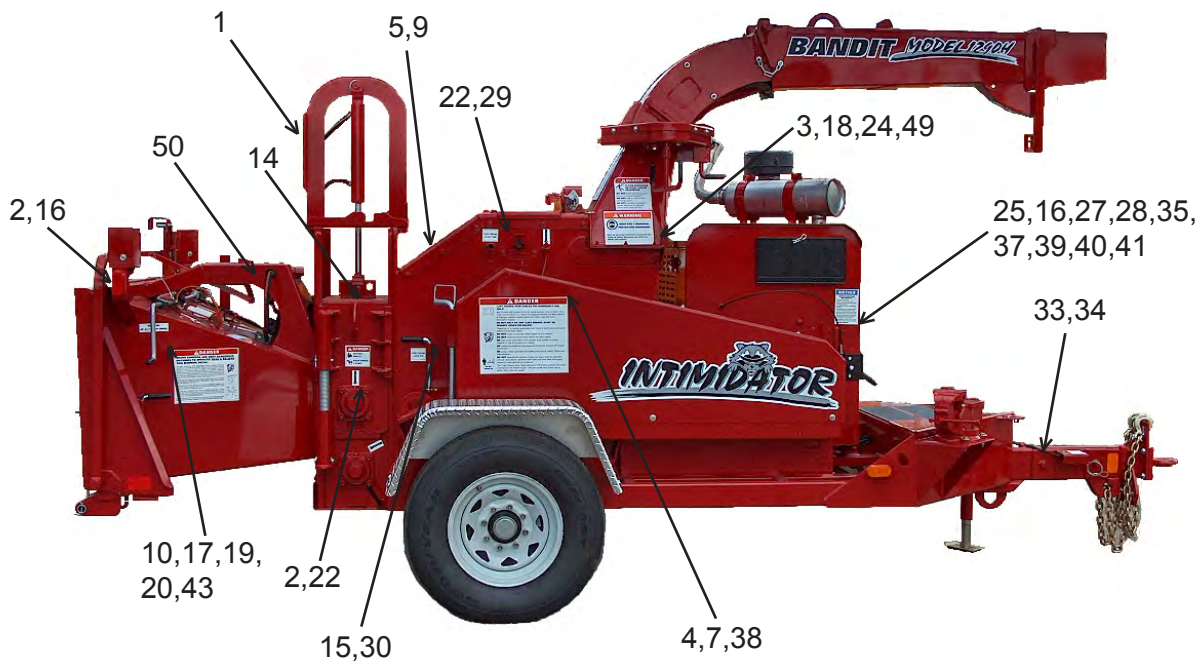
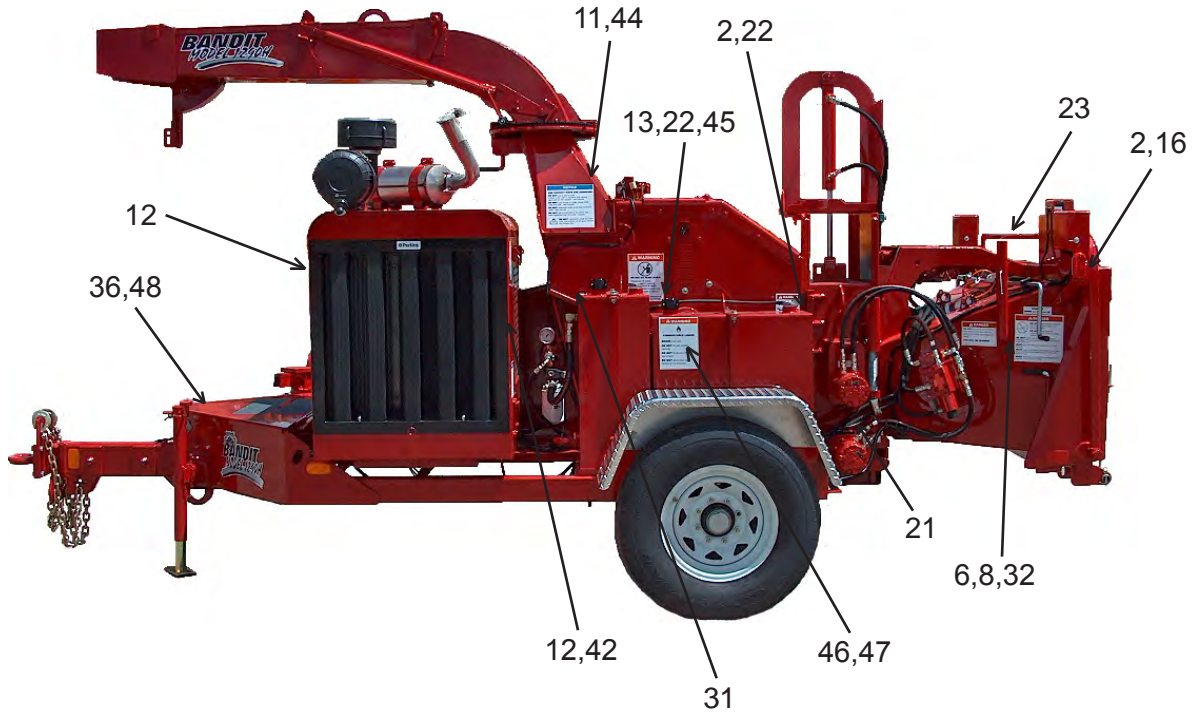

DECAL LOCATIONS - MODEL 1290XP

Modifications and/or additions of decals to this list will happen.
Consult chipper dealer or manufacturer for most current decal package.

LOCATION	NUMBER	DESCRIPTION
37.	N-02	Maintain Lubrication...
38.	N-03	Service Required Under Beltshield...
39.	N-05	Frequently Adjust...PTO...
40.	SPN-06	Decal Maintenance...
41.	N-07	Clutch Operation...
42.	N-08	Patents...
43.	N-09	Adjustable Feed Speed...
44.	SPN-11	Correct Knife And Hardware...
45.	SPW-01	Do Not Go Near Oil Leaks...
46.	SPW-02	Diesel Fuel Only...
47.	SPW-03	Gasoline Fuel Only...
48.	SPW-04	Frozen Battery Can Explode...
49.	SPW-08	Wear Personal Protection...
50.	SPW-10	Hydraulic Winch...
51.	900-8900-30	Basic Safety Decal Kit (Options may require additional decals)
52.	900-8900-21	Bandit Model 1290XP Logo Decal Kit

Additional Decals for Machine Equipped With A Track Undercarriage - Consult dealer or manufacturer for general locations.

53.	SPD-19	...Minimum 10 Feet Away From Tracks...
54.	SPD-38	Do Not Entangle Feet...
55.	INST-125	Selector Winch / Feed
56.	INST-126	Winch Out / In
57.	INST-127	Selector Winch / Track
58.	INST-135	Remote Starting Procedure
59.	INST-137	Remote / Tether
60.	SPW-06	Do Not Attempt...Slope Of More Than...
61.	SPW-07	Do Not Move Machine...Horn Is Blown...
62.	SPW-11	Do Not Leave Unit Parked On A Slope...
63.		Bandit Track Logo Decal Kit

Note: Some decals are for optional equipment. Decal locations may vary, these are general locations. If any decals become damaged, replace immediately.

DECAL LOCATIONS - MODEL 1590

Decal locations may vary, these are general locations.

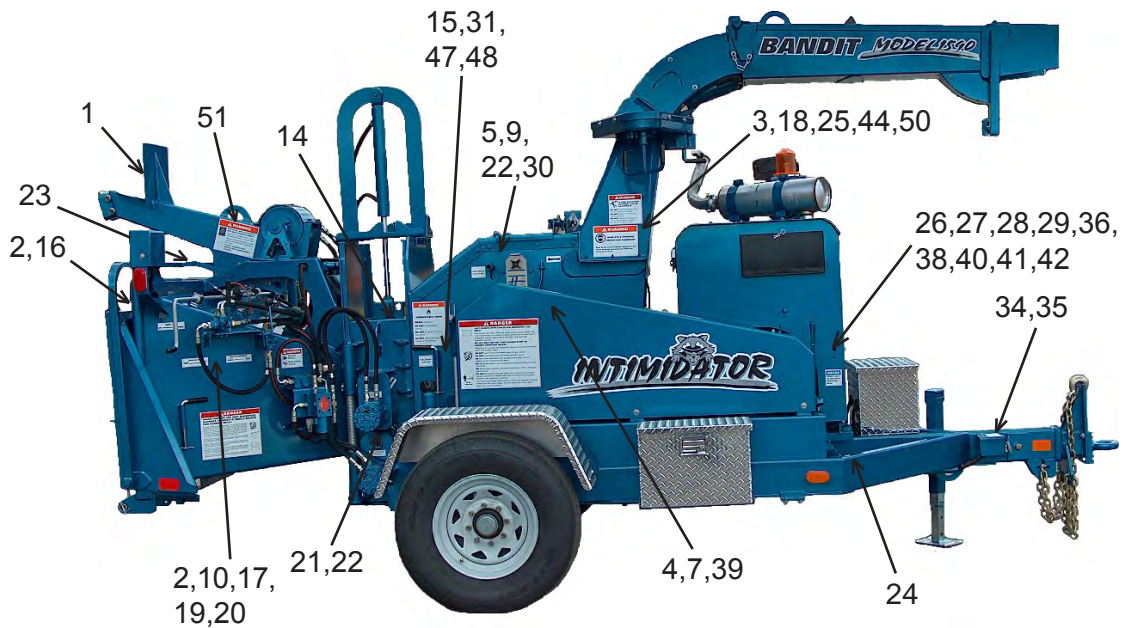
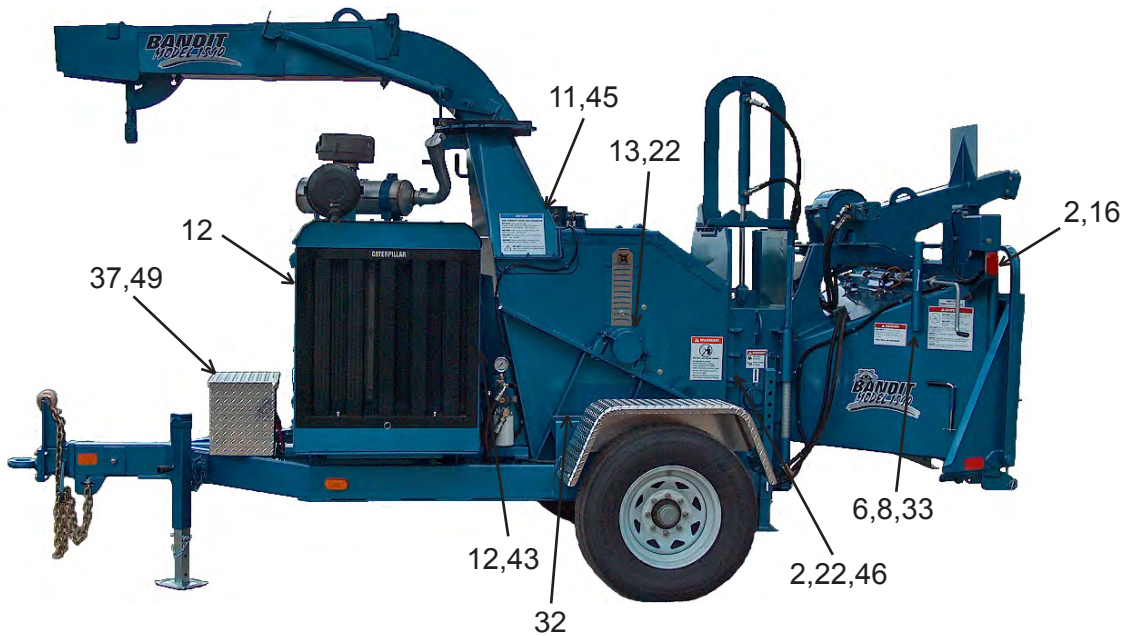

DECAL LOCATIONS - MODEL 1590

Modifications and/or additions of decals to this list will happen.
Consult chipper dealer or manufacturer for most current decal package.

LOCATION	NUMBER	DESCRIPTION
1.	SPD-01	Avoid Injury Or Death...
2.	SPD-02	Moving Parts...
3.	SPD-04	Flying Discharge Material...
4.	SPD-07	Last Chance Stop Cables...
5.	SPD-09	Not Work Under Top Feed...
6.	SPD-12	Do Not Feed Vine-Like...
7.	SPD-28	Do Not Insert Fingers
8.	SPD-30	Do Not Sit, Stand, Lay, Climb...
9.	SPD-33	Do Not Work Under...
10.	SPD-34	Brush Chippers Are Very Dangerous...
11.	SPD-37	Lockout All Energy Sources...
12.	ID-42	Bandit Industries Inc...USA
13.	INST-01	Remove To Check Torque...
14.	INST-02	Yoke Lock Hole
15.	INST-03	Yoke Lock Bar
16.	INST-04	Arrow
17.	INST-05	Yoke Lift Up / Down
18.	INST-07	Discharge Swivel Right / Left
19.	INST-08	Winch Control Out / In
20.	INST-09	Selector Winch / Feed
21.	INST-11	Motor Coupler Guard...
22.	INST-12	Grease Daily (Arrow)
23.	SPINST-13	Push To Reverse
24.	INST-14	Articulating Tongue Out / In
25.	INST-15	Flipper Down / Up
26.	INST-16	Grease Weekly Arrow
27.	INST-39	Oil Daily Arrow
28.	INST-44	California Proposition 65
29.	INST-46	Autofeed Basic Info...
30.	INST-48	Disc/Drum Lock Tube
31.	INST-49	Disc/Drum Lock Pin
32.	INST-53	Hydraulic Oil...Hydrex XV...
33.	INST-76	Yoke Lift Down / Up
34.	INST-90	Tongue Up / Down
35.	INST-95	Electric Plug-In Schematic
36.	INST-101	Canada Engine Decal
37.	INST-109	Basic Maintenance Check List

Note: Some decals are for optional equipment. Decal locations may vary, these are general locations. If any decals become damaged, replace immediately.

DECAL LOCATIONS - MODEL 1590

Decal locations may vary, these are general locations.

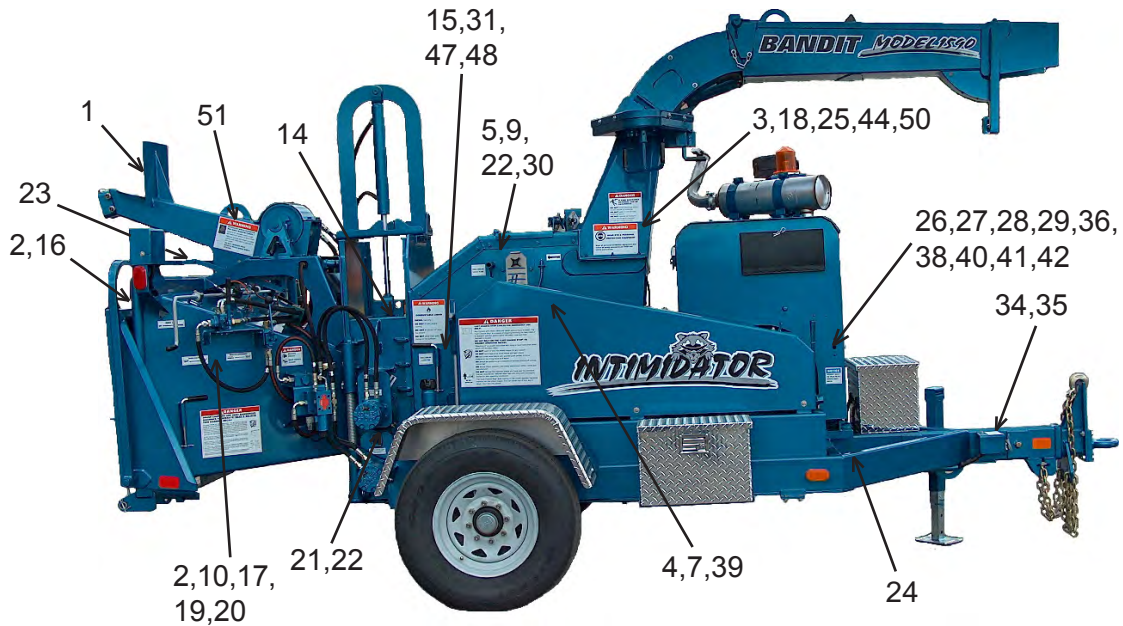
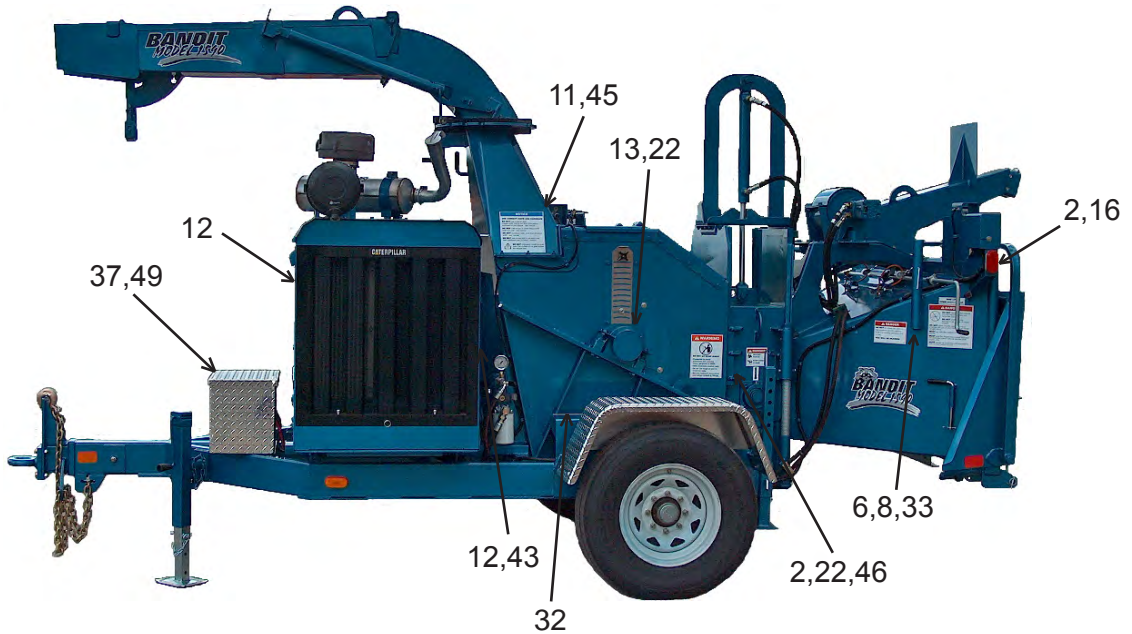

DECAL LOCATIONS - MODEL 1590

Modifications and/or additions of decals to this list will happen.
Consult chipper dealer or manufacturer for most current decal package.

LOCATION	NUMBER	DESCRIPTION
38.	N-02	Maintain Lubrication...
39.	N-03	Service Required Under Beltshield...
40.	N-05	Frequently Adjust...PTO...
41.	SPN-06	Decal Maintenance...
42.	N-07	Clutch Operation...
43.	N-08	Patents...
44.	N-09	Adjustable Feed Speed...
45.	SPN-11	Correct Knife And Hardware...
46.	SPW-01	Do Not Go Near Oil Leaks...
47.	SPW-02	Diesel Fuel Only...
48.	SPW-03	Gasoline Fuel Only...
49.	SPW-04	Frozen Battery Can Explode...
50.	SPW-08	Wear Personal Protection...
51.	SPW-10	Hydraulic Winch...
52.	900-8900-30	Basic Safety Decal Kit (Options may require additional decals)
53.	900-8900-23	Bandit Model 1590 Logo Decal Kit

Additional Decals for Machine Equipped With A Track Undercarriage - Consult dealer or manufacturer for general locations.

54.	SPD-19	...Minimum 10 Feet Away From Tracks...
55.	SPD-38	Do Not Entangle Feet...
56.	INST-125	Selector Winch / Feed
57.	INST-126	Winch Out / In
58.	INST-127	Selector Winch / Track
59.	INST-135	Remote Starting Procedure
60.	INST-137	Remote / Tether
61.	SPW-06	Do Not Attempt...Slope Of More Than...
62.	SPW-07	Do Not Move Machine...Horn Is Blown...
63.	SPW-11	Do Not Leave Unit Parked On A Slope...
64.		Bandit Track Logo Decal Kit

Note: Some decals are for optional equipment. Decal locations may vary, these are general locations. If any decals become damaged, replace immediately.

DECALS

Decals located on your Bandit equipment contain useful information to assist you in operating your equipment safely. Some of the decals on your machine and their location are shown in this section.

It is very important that all decals remain in place and in good condition on your machine. Please follow the care and instructions given below:

- 1) You should use soap and water to keep your decals clean. Never use mineral spirits or any other abrasive cleaners.
- 2) Replace immediately any missing or damaged decals. The location the decal is going to be applied to must be clean and dry, and at least 40° F (5°C) before applying decal.
- 3) When the need arises to replace a machine component with a decal attached, be sure and replace the decal.
- 4) Replacement decals are available, and can be purchased from the manufacturer or your Bandit Dealer.
- 5) Combination English / Spanish decals are typically standard. Other foreign language decals are available and may be purchased. Mail translated decals required to Bandit Industries, Inc.

EXAMPLES:

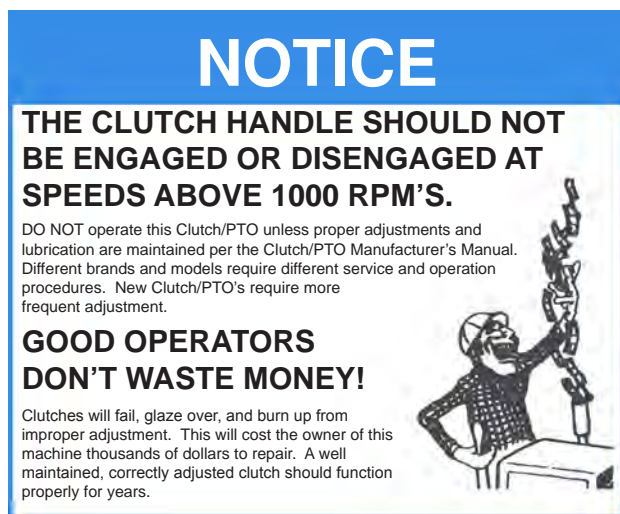



! DANGER

AVOID INJURY OR DEATH!

DO NOT OPERATE THIS MACHINE UNLESS:

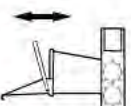







- Only properly and fully trained people are used.
- Wearing clothing and personal protective equipment per ANSI Z133 and OSHA 29-1910 standards.
- Constantly prepared and positioned to activate the feed control bar.
- All guards and covers are secure and in place.
- Only factory approved pins, guards and replacement parts are used.
- All safety devices and controls are operational.
- Never allow hand, foot or body part to enter infeed hopper during operation or while running.
- All decals are legible, in place and operator thoroughly understands them.
- Never open chipper hood cover while disc/drum is turning or engine is running.

Follow all safety and operational instructions per manuals decals, video, ANSI Z133 and OSHA 29-1910 standards.

! WARNING



DO NOT GO NEAR LEAKS!

- Pressured oil easily punctures skin causing injury, gangrene or death.
- Seek immediate medical care.
- Do not use finger or skin to check for leaks.
- Remove hydraulic pressure or load before loosening fittings.

! DANGER

LAST CHANCE STOP CABLES FOR EMERGENCY USE ONLY!

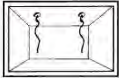

Any Contact with infeed rollers will cause serious injury or death. The "Last Chance Stop" is a means of stopping/reversing the feed rollers if a negligent operator doesn't follow the safety rules and finds themselves in trouble!

DO NOT RELY ON THE "LAST CHANCE STOP" TO DISOBEY OPERATOR RULES!!

"Reaching in" is usually associated with trying to hand feed small wood debris into the feed rollers.



DO NOT reach or kick into infeed hopper for any reason!
DO NOT hand feed small wood debris into feed rollers!
DO feed small wood debris with wooden push paddle, or throw material on top of big wood as it feeds!
DO always be positioned and prepared to activate forward-off-reverse control bar!
DO always follow operation and safety instructions! (ANSI, OSHA and manufacturer)
DO NOT operate this machine unless you have read the operators manual, read decals, watched video tape and have been thoroughly trained for safe operating procedures!



DO NOT REACH IN!

The "Last Chance Stop" does nothing for the foolish operator that kicks material into the infeed hopper. This can cause loss of foot, leg or death. Don't kick into infeed!

! DANGER

BRUSH CHIPPERS ARE VERY DANGEROUS MACHINES TO OPERATE! READ & BELIEVE THIS WARNING DECAL!

The chipper feedrolls are VERY DANGEROUS. They are designed to pull large diameter trees of any length into the chipper. Pulling your hand, arm, foot or entire body through the machine is much easier than pulling a tree. FOLLOW the operating instructions in the operator's manual, and ALWAYS be in a position to activate the *Forward-Off-Reverse Control Bar*. NEVER take chances pushing wood too far into the infeed hopper of the chipper. NEVER use your feet to try to kick wood into the machine. There have been ACCIDENTS involving the feed rolls, resulting in the amputation of hands, arms, feet, legs and DEATH. DO NOT let this happen to you!

DO NOT open the chipper hood without letting the chipper disc come to a complete stop. THIS MEANS A COMPLETE STOP - NOT ALMOST! WAIT at least 3 minutes before disengaging the hood lock pin.

NEVER operate the chipper without the hood lock pin SECURELY installed and the hood lock pin padlock LOCKED. Failure to do this will allow the chipper hood to slam to the open position and possibly injure someone.

There have been ACCIDENTS, all of them were SERIOUS INJURIES or DEATH involved with chipper hoods flying open and hitting someone. In ALL of the cases the hood lock pin was NOT INSTALLED PROPERLY. DO NOT operate this chipper if the hood lock pin is not LOCKED INTO POSITION.

DO NOT OPERATE THIS MACHINE UNLESS YOU HAVE READ THE OPERATOR'S MANUAL AND HAVE BEEN TRAINED FOR SAFE OPERATING PROCEDURES!

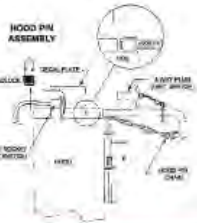

CONTROL BAR

AUTOFEED OPTIONS AUTOFEED SYSTEM

Consult the original manufacturer's manual for your chippers
Autofeed operating and maintenance procedures

When processing material through the chipper, the feed system will automatically stop when the engine drops below a preset RPM point. The engine is constantly being monitored by an adjustable electronic speed switch. The switch can be adjusted so that at a given RPM, an electronic relay system will operate the hydraulic solenoid valves to stop the feedwheels until the engine has recovered speed. The patented "Autofeed Plus" system will reverse the feedwheels for a set period of time and then stop until the engine has recovered speed. Both autofeed systems will then automatically turn the feed on to resume forward travel.

Due to required components and equipment options a machine may have various types or brands of autofeed systems. Each chipper is shipped with the original manufacturer's manual for the autofeed system it is equipped with.

For the approximate autofeed settings on all optional autofeed systems refer to page 28 of the chipper manual. For part numbers on the hydraulic portion of the autofeed systems refer to pages 98 & 99 of the chipper manual.

Do not power wash the digital tach hour meters. Pressure causes unwarranted damage. **Do not spray tach, this will void warranty.**

PART NUMBERS FOR AUTOFEED DIGITAL TACH HOUR METERS

<div style="text-align: center;"> <p>ESI Intelli-Feed Part Number: 900-2908-11 For Service Call 1-815-985-0383</p>  </div>	<div style="text-align: center;"> <p>Electronic Solutions Part Number: 900-2904-85 For Service Call 1-866-736-6839</p> <p>No longer used.</p>  </div>
<div style="text-align: center;"> <p>L.O.R. MFG. Part Number: 900-2906-82L For Service Call 1-866-644-8622</p>  </div>	<div style="text-align: center;"> <p>Miratron Inc. Part Number: 900-2910-68 For Service Call 1-866-285-0132</p> <p>No longer used.</p>  </div>

AUTOFEED TERMINOLOGY

- PPR** Pulses per revolution. On magnetic pick-up machines, this setting will be the number of teeth on the gear or sprocket it is reading. On alternator pick-up machines, the setting will need to be obtained from your local dealer or Bandit Industries.
- Mag Pick-up** Magnetic pick-up, also called pick-up probe. This is normally located screwed into the flywheel housing on the engine block. It can also be found on the clutch housing or chipper shaft. See Figure 1.
- Dump Block** This block is used in most cases. It is located near the fender on the frame of the chipper. An easy way to find it is by following the hydraulic hose from the pump. The block will be the first thing it is hooked into. This block also contains the main relief. When the solenoid is activated (indicated by the light in the connector) the feedwheel(s) are stopped by the autofeed system. See Figure 2.
- Reverse Valve** Located on the infeed hopper of the chipper. It can be recognized by a valve with one solenoid bolted on a square block. The solenoid is approximately 2-1/2" (63.5mm) diameter x 2-3/4" (69.9mm) long. It will have two wires coming from it or on the newer machines it will have a connector with a light screwed to it. When the solenoid is activated (indicated by the light in the connector) the feedwheel(s) are reversed by the autofeed plus system. See Figure 3.
- Dual Coil Reverse Valve** Normally seen on bigger machines such as 280, 1850, 1890, 1990, 2090, etc. and special options. This will normally be located on the infeed hopper of the machine. It can be recognized by a valve with two solenoids bolted on a square block. The solenoid is approximately 2-1/2" (63.5mm) diameter x 2-3/4" (69.9mm) long. It will have two wires coming from it or on the newer machines it will have a connector with a light screwed to it. The feed coil must have power (indicated by the light in the connector) for the feedwheels to feed and pull material in. See Figure 4.
- Solenoid** Electronically activated to produce a magnetic pull which shifts the spool inside the hydraulic valve. Shifting of the spool changes oil flow direction from operating forward or dumping oil to tank.
- High** High or HI is the setting when the feedwheels will turn back on (feeding operation).
- Low** Low or LO is the setting when the autofeed will reverse (if equipped) the feedwheels and then turn the feedwheels off.
- Back** Amount of time in seconds the feedwheels will back the wood away from the cutter disc/drum. Normally this will be set at .3 seconds.

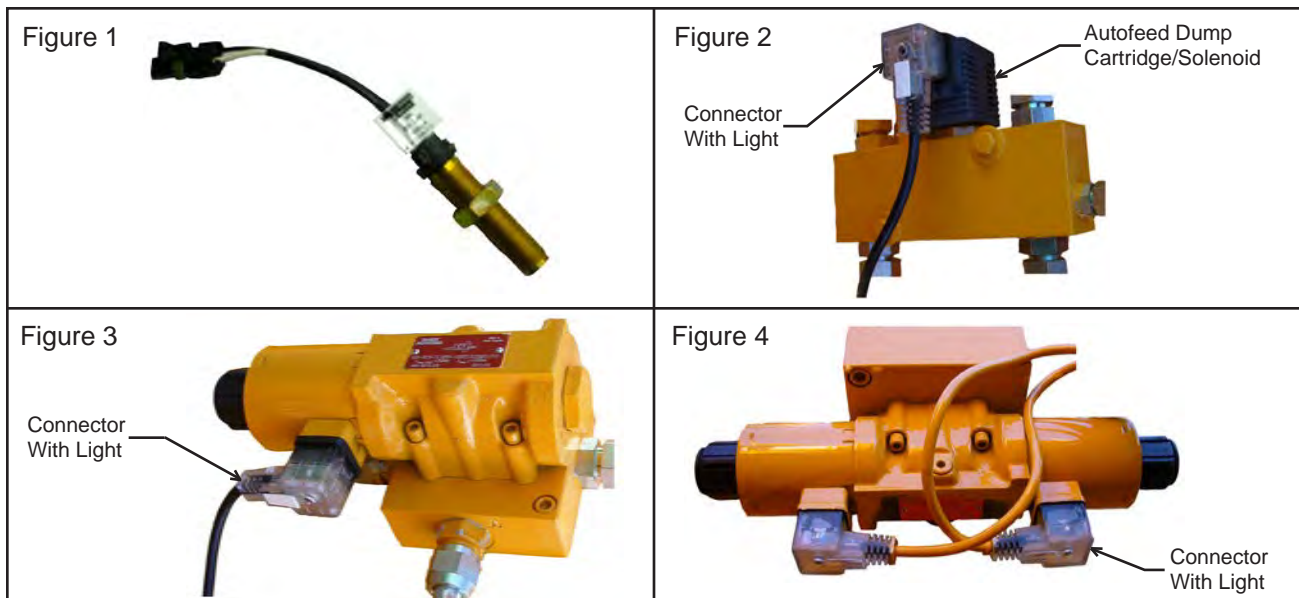



TROUBLE SHOOTING GUIDE

PROBLEM	POSSIBLE CAUSE	SOLUTION
No Display	-Gauge not getting power.	-Check continuity of Red wire to a clean power source. -Check 7.5 amp fuse. -Check connection at engine disable plug at hood pin. -Check key switch for switched power in and out.
	-Gauge not properly grounded.	-Check continuity of Black wire to ground connection.
	-Dead Battery.	-Charge or replace.
Feedwheels Do Not Stop (Autofeed Doesn't Activate)	-Loose chipper belts.	-Tighten or replace per manual specifications.
	-Clutch slipping.	-Adjust per clutch manufacturer's recommendations.
	-Sticky dump cartridge.	-Lightly tap on dump block to free up. -Take cartridge out and clean free of debris. -Replace solenoid and/or cartridge.
	-No power to dump valve solenoid.	-Check fuse on dump valve signal wire (if equipped). -Check continuity on the dump valve wire (normally green wire).
	-Faulty tach.	-Check autofeed tachometer settings.
	-Low or "LO" setting wrong.	-Check autofeed tachometer settings.
Feedwheels Do Not Re-engage	-Engine RPM not reaching HI set point on tach.	-Check for stretched or out of adjustment throttle cable. This would not engine reach full RPM. -Check HI RPM setting on gauge to make sure it is not set too close to full RPM of engine. HI setting should be 150 to 200 RPM below full engine RPM.
	-Sticky dump cartridge.	-Lightly tap on dump block to free up. -Take cartridge out and clean free of debris. -Replace solenoid and/or cartridge.
	-System pressure.	-Check and readjust per manual specifications.
	-Faulty tach.	-Consult local dealer or Bandit Industries.
No Signal	-Engine not running.	-Normal operating condition.
	-Bad signal wire.	-Check continuity on the signal wire (white wire in autofeed harness).
	-No signal from alternator.	-Check for at least 3.5 VAC output at idle and 10-12 VAC at HI RPM.
	-No signal from mag pick-up.	-Check for approx. 2-7 VAC at idle and approx. 14-20 VAC at HI RPM. Testing must be done at the two wires coming out of mag pick-up after disconnecting. Remove and clean off magnet at end. Reinstall by turning it in until it bottoms out. Then back off approx. 1/2 a turn. Lock with jam nut.
	-Bad mag pick-up.	-Replace mag pick-up.
Gauge Jumped Program	-Low voltage to tach.	-Check engine disable plug at hood. Clean and check for tight connection. Re-install using dielectric grease.
	-Shorts in wire harness.	-Check for possible worn wires or loose connections.
	-Faulty ground.	-Check black wire for a good ground.
	-Faulty tach.	-Consult local dealer or Bandit Industries.

TROUBLE SHOOTING GUIDE cont.

PROBLEM	POSSIBLE CAUSE	SOLUTION
Feedwheels Run In Reverse From Normal	-Backup time set wrong.	Reset backup time. Normal setting is .3 seconds.
	-Sticking reverse valve.	-Check solenoid operation. -Override cartridge manually by sticking a small allen wrench in the end of the solenoid. -Replace solenoid and/or cartridge.
	-Type settings programmed wrong.	-Reprogram or consult local dealer or Bandit Ind.

NOTE: Autofeeds with dump blocks can be unplugged and run manually. Autofeeds with dual output block will need a jumper plug. This can be a good test to determine if you problem is hydraulic or electronic.

LOR Jumper Plug Part No.: 900-2913-51		ESI Jumper Plug Part No.: 900-2914-09	
--	---	--	---

**APPROXIMATE DIGITAL AUTOFEED SETTINGS
(FOR ALL AUTO FEED SYSTEMS - REFERENCE ONLY)**

Some Current Engine Types	Maximum RPM	Alternator PPR	Magnetic Pick-Up PPR	Off RPM	On RPM	ALR (LOR only)	Feed Reverse Time
Caterpillar 3054 - 86 Hp	2500	N/A	126	2350	2150	N/A	.3
Caterpillar 3054 - 115 Hp	2425	N/A	126	2275	2050	N/A	.3
Caterpillar 3054 - 130 Hp	2340	N/A	126	2190	1900	N/A	.3
Caterpillar 3054 - 140 Hp	2380	N/A	126	2230	1900	N/A	.3
Cummins B3.3 - 65 Hp	2500	N/A	110	2350	2150	N/A	.3
Cummins B3.3 - 85 Hp	2500	N/A	127	2350	2150	N/A	.3
Cummins B3.9 - 110, 130 Hp	2500	N/A	159	2350	2150	N/A	.3
Cummins B3.9 - 125 Hp	2450	N/A	159	2300	2150	N/A	.3
Deutz F4M - 66 Hp	2800	12.5	N/A	2650	2400	50	.3
Deutz BF4M - 88 Hp	2800	12.5	N/A	2650	2400	50	.3
John Deere 4045 - 80, 100 Hp	2500	N/A	30	2350	2150	N/A	.3
John Deere 4045 - 115, 125 Hp	2500	N/A	129	2350	2150	N/A	.3
John Deere 4045 - 140 Hp	2400	N/A	129	2250	2050	N/A	.3
John Deere 4024 - 66 Hp	2800	N/A	30	2650	2400	N/A	.3
John Deere 5030 - 75, 84 Hp	2800	N/A	30	2650	2400	N/A	.3
Kubota V3300 - 73, 90 Hp	2600	12.5	N/A	2450	2200	N/A	.3
Perkins 1104C - 86 Hp	2500	N/A	126	2400	2150	50	.3
Perkins 1104C - 115 Hp	2425	N/A	126	2275	2050	50	.3
Perkins 1104C - 130 Hp	2340	N/A	126	2190	1900	N/A	.3
Perkins 1104C - 140 Hp	2380	N/A	126	2230	1900	N/A	.3
Some Prior Engine Types							
CAT / Perkins 125 Hp - Tier 1	2400	126	126	2250	2050	10	.3
CAT / Perkins 115 Hp - Tier 1	2500	126	126	2350	2150	50	.3
Cummins 4B - 80 to 130 Hp	2500	159	159	2350	2150	N/A	.3

CONTROLS

CORRECT OPERATION OF FEED CONTROL HANDLE

FOR ALL CHIPPERS DESIGNED TO BE "HAND FED".

IF YOU ARE IN THE AREA OF INFEED HOPPER, ALWAYS BE PREPARED TO OPERATE AND WITHIN EASY REACH OF THE FEED CONTROL HANDLE.

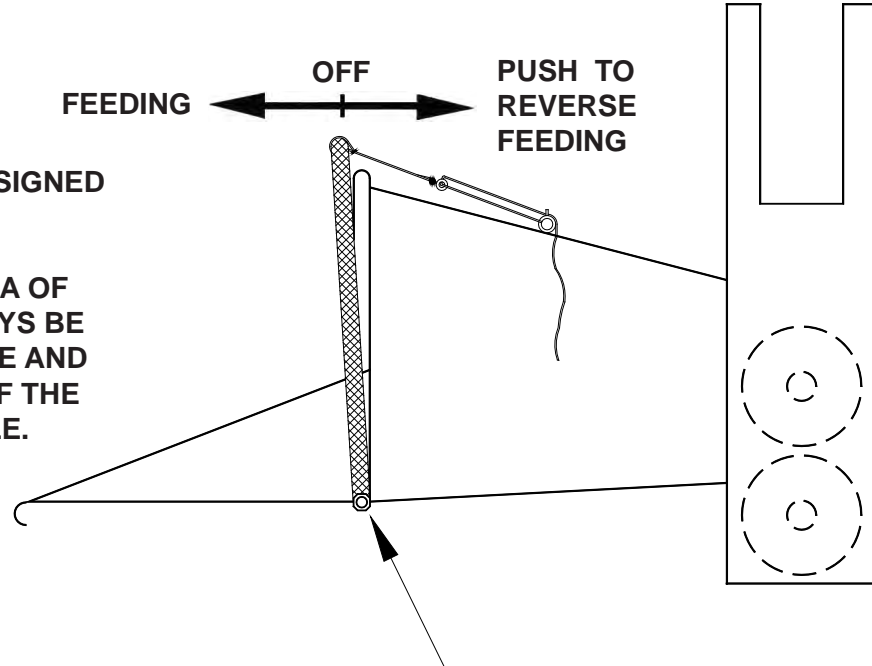

USE THE 1" JAM NUT TO ADJUST CONTROL HANDLE PIVOT TENSION.

ADJUSTING TENSION FOR CONTROL HANDLE PIVOT AND LAST CHANCE CABLE PULL.

NORMAL WEAR REQUIRES PERIODICAL ADJUSTMENT OF PIVOT TENSION.

FEED CONTROL HANDLE SHOULD PIVOT WITH LITTLE EFFORT, BY HAND OR WITH A PULL ON "LAST CHANCE" CABLES. LUBRICATE PIVOT POINTS OF FEED CONTROL HANDLE WEEKLY.

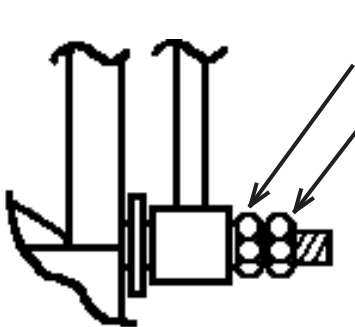

ADJUST PIVOT TENSION WITH THE TIGHTNESS OF INSIDE FRICTION NUTS.

SECURE ADJUSTMENT WITH OUTSIDE JAM NUTS.

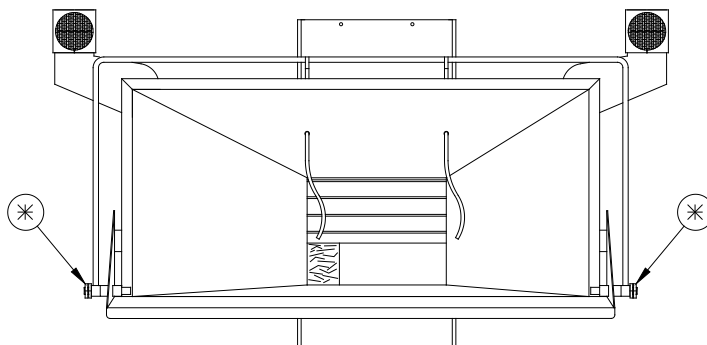

CONTROLS

Models 1290XP/1590 Basic Location of Controls and Adjustments

LOCATION SHOWN

1. Foot Pad Jack
2. Chipper Belts / Pump Belts
3. Lug Nuts
4. Motor Coupler
5. Infeed Hopper
6. Folding Infeed Pan
7. Feedwheel Control Bar
8. Hydraulic Control Valves
9. Hydraulic Winch Area "Optional"
10. Wooden Push Paddle
11. Yoke Lift Cylinder "Optional"
12. Knives & Hardware
13. Swivel Discharge "Optional"
14. Discharge Chute
15. Discharge Flipper Adjuster
16. Engine Controls, Adjusters
17. Clutch Handle
18. Engine Throttle Adjuster
19. Autofeed Controls "Optional"

NOT SHOWN

"Bandit" Lever Throttle Adjuster

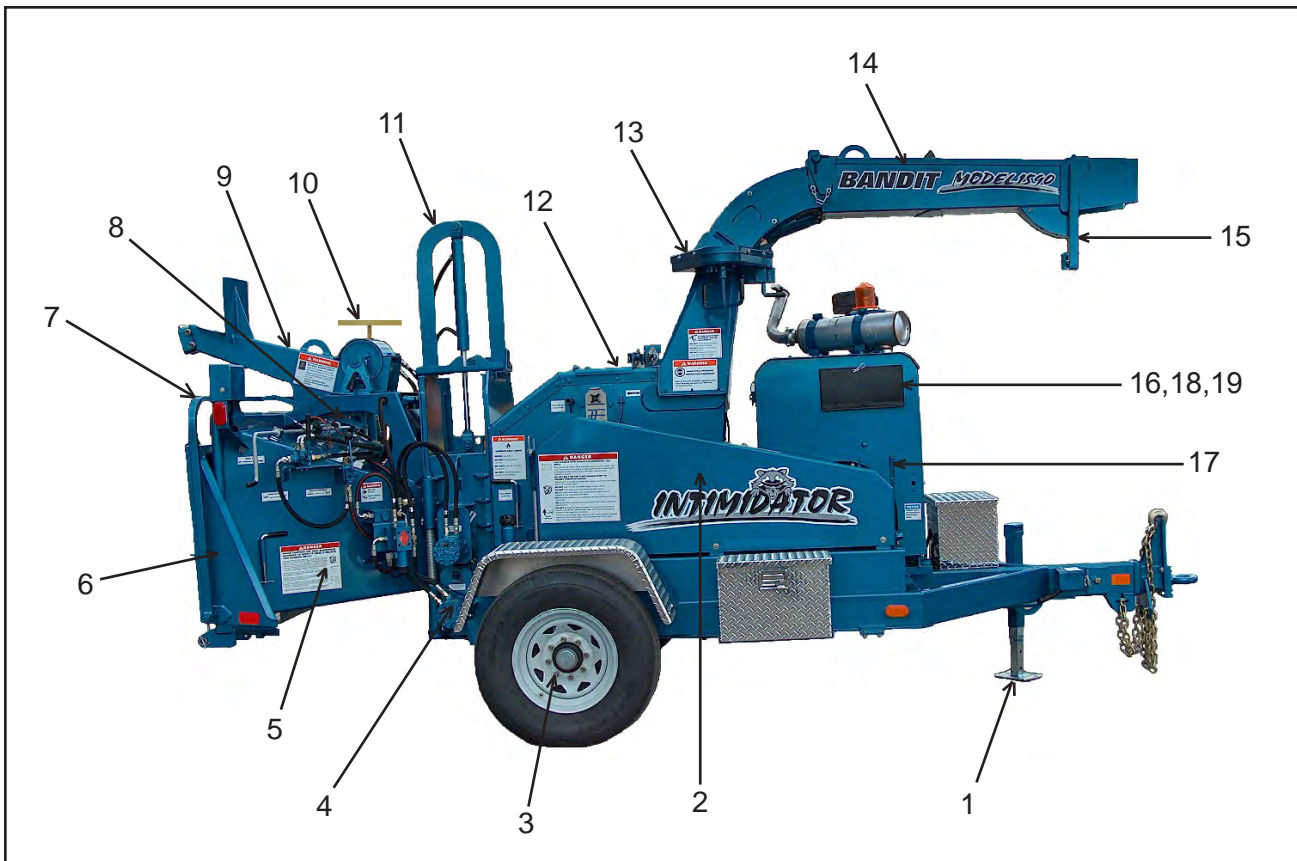

Bandit

CONTROL OPERATING PROCEDURES

Feedwheel Control Bar:

The feedwheel control bar operates the feedwheel(s). To make the feedwheel(s) operate so they are pulling material into the machine, pull the control handle towards the operator away from the chipper. To make the feedwheel(s) operate so they are pushing material out of the machine, away from the chipper disc/drum, the control handle should be pushed away from the operator, away from you and towards the machine. The control bar is in the off position when it is in the center location.

Yoke Lift Control - Optional:

The yoke lift control operates the top yoke lift cylinder. To lower the yoke, push the yoke lift control handle towards the tongue of the machine. To raise the yoke, push the yoke lift control handle towards the infeed hopper of the machine. The yoke lift control handle is in the off position when it is in the center location.

Selector Valve Control - Optional:

The selector valve control allows the operator to change the operation function from the feed function to the winch function or from the winch function to the feed function. The feedwheel(s) will not operate when the selector valve is in the winch function and the winch will not work while the selector valve is in the feed function. To have the feedwheel(s) operate the selector valve needs to be pushed in, away from the operator. To operate the winch the selector valve needs to be pulled out, towards the operator.

Winch Control - Optional:

The winch control operates the winch option. To make the winch reel out push the winch control handle in, away from the operator. To make the winch pull material in pull the winch control handle out, towards the operator. The winch also has a spool rotation lock, make sure this is disengaged to free wheel cable out of spool.

Discharge Swivel Control - Optional:

NOTE: Remove transport bolt and/or lock pin BEFORE operating this function.

The discharge swivel control operates the discharge rotate. To make the discharge swivel to the right pull the discharge swivel control handle out, towards the operator. To make the discharge swivel to the left push the discharge swivel control handle in, away from the operator. The discharge swivel control handle is in the off position when it is in the center location. Do not use the hydraulics to secure the discharge when transporting the chipper. Make sure to install the lock bolt and nut before transporting.

Discharge Hydraulic Flipper Control - Optional:

The discharge hydraulic flipper control operates the discharge flipper cylinder. To make the discharge flipper rotate up push the discharge hydraulic flipper control handle in, away from the operator. To make the discharge flipper rotate downward pull the discharge hydraulic flipper control handle out, towards the operator. The discharge hydraulic flipper control handle is in the off position when it is in the center location.

Hydraulic Tongue Jack Control - Optional:

NOTE: Remove lock pin BEFORE operating this function.

The hydraulic tongue jack control operates the hydraulic tongue jack cylinder. To raise the front of the machine pull the hydraulic tongue jack control handle up, away from the ground. To lower the front of the machine push the hydraulic tongue jack control handle down, towards the ground. The hydraulic tongue jack control handle is in the off position when it is in the center location. Install the lock pin at the desired tongue height.

WINCH OPERATING PROCEDURES

⚠ DANGER

Brush being fed into the chipper infeed hopper can snag an extended winch line. The knives on the spinning disc/drum can grab and pull in the winch line at a high rate of speed resulting in serious injury or death to workers nearby.

⚠ DANGER

The winch line is under tension at times and could suddenly release, snapping back into the operator causing serious injury or death.

⚠ DANGER

Never operate the hydraulic winch with the wood chipper detached from the towing vehicle. The load may move the wood chipper or pull the tongue off the support blocking.

⚠ DANGER

Climbers' ropes and other lines present at the work site can become entangled in brush being fed into the chipper. The knives on the spinning disc/drum can grab and pull in ropes at a high rate of speed resulting in serious injury or death to workers nearby.

⚠ DANGER

Follow all winch operating procedures, if not followed severe injury or death can result.

- The intended use of the winch is to assist the operator with pulling large tree limbs to the wood chipper feedwheels without having to lift and carry.
- Pinch point hazards may develop during winching operations. The hydraulic controls are located on the side of the infeed hopper. Operating the winch is a one-man operation. Do not have one person operating the winch hydraulic control with another person operating or holding the winch line. The person holding the winch line could have his hand pinched when another person is operating the winch control.
- Winching large limbs to the wood chipper should be performed by one person.
- Stay clear when winching.
- Do not allow winch line or other ropes to be snagged and pulled into the chipper knives.
- Avoid becoming entangled in the winch line. Never place yourself between the brush and the winch line while using the winch line to pull large tree limbs toward the chipper.
- The metal hook at the end of the winch line entering the wood chipper could result in serious damage to the knives and other internal components causing the potential for injury to operators.
- When you are not using the winch, ensure that it is retracted and stowed so that it can not be pulled into the chipper.
- Never pull out the winch line while brush or limbs are feeding into the chipper.
- Never attach winch line to an installed choker if other limbs are feeding into the machine.
- Brush can snag winch line or climbers' ropes. Knives can grab and pull in line and anything attached to it at a high rate of speed.
- If you are in between the chipper and the winch line that is caught in the knives, the winch line will be pulled in at a very rapid speed and you will not have time to get out of its way. Death or serious injury may result.
- Do not overload the winch. The cable can break or the choker can come off and strike a worker.
- Be aware of the hazards of winch line breakage. Ensure that everyone remains clear of the recoil area in the event of load or cable breakage.
- Pull loads in a manner that avoids angles which could result in tipping or other unintended movement of the chipper and towing vehicle.

⚠ DANGER

Most winch lines contain a metal hook at the end. If the metal hook enters the infeed hopper, it could be ejected out of the discharge chute at a high rate of speed causing serious injury or death.

⚠ DANGER

Make sure there is outbound tension on the winch line whenever the winch line is being powered out. Using the hydraulic control to power out the winch line rather than free spool the line out could result in the line becoming tangled around the spool and wind inward when the hydraulic lever is in the unwind position. If a worker is holding the winch line when this happens a potential nip point is created between the cable housing and hook and also the the winch line and material.

NOTICE

Before operating machine, you must have all potential operators; read and understand manuals and decals, watch the video and follow the recommendations.

WINCH OPERATING PROCEDURES

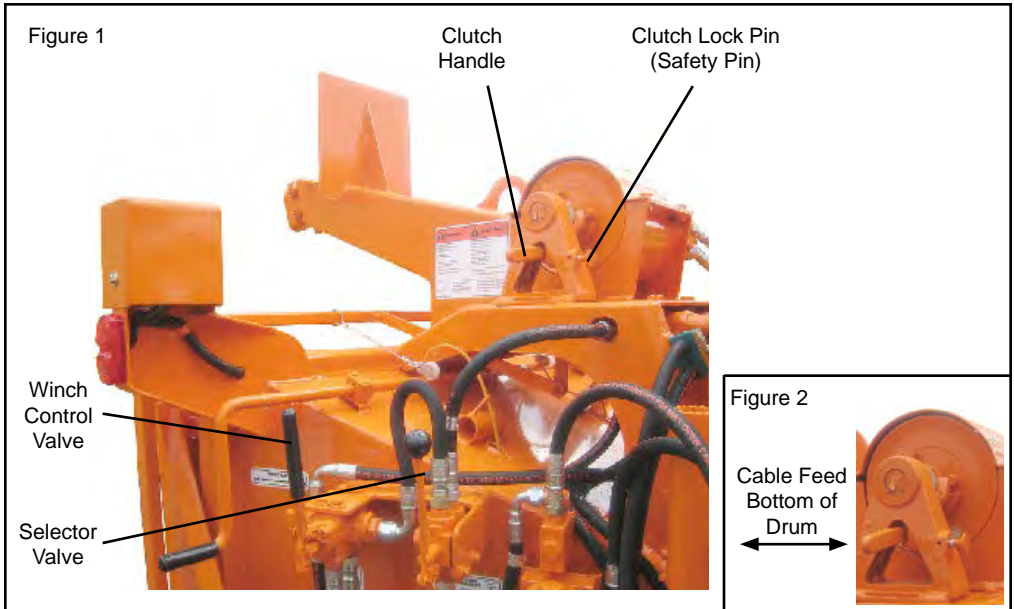

⚠ WARNING

HYDRAULIC WINCH OPERATION PER WINCH MANUFACTURER!

Install the cable to pull and feed from the bottom of the winch drum (see Figure 2). Remove excess bolt length on cable bolts after cable is secured to the spool.

⚠ DANGER

Never reach into the winch or winch roller area.

OPERATING PROCEDURE

1. Winch operation is a one person job. This means the person who hooks the winch to the wood material is the same person who engages the winch.
2. Place the feedwheel control bar in the off position. Make sure the chipper and towing vehicle are blocked or anchored in a solid location.
3. Locate the selector valve and engage it to the winch position. The feed system should not operate with the selector valve in this mode.
4. Make sure the winch clutch is disengaged and pull the cable to the material to be reeled in. Attach cable securely to the wood material that you want pulled to the chipper.
5. Make sure everyone is clear and then retract the clutch lock pin and then pull the clutch handle up to engage the winch clutch (see Figure 1). Make sure the handle is locked in position.
6. Use the winch control valve or the radio remote control (if applicable) to now pull the wood material towards the machine.
7. Once the wood material is pulled to the machine, unhook it from the winch and make sure the cable is completely reeled back in and out of the way. Attach the cable to the keeper loop. Make sure the cable is clear of the feedwheel(s) or severe damage can occur if the cable should enter the chipper.
8. Reengage the selector valve to the feed position.
9. Engage the feedwheel(s) and begin feeding wood material.

CHIPPER HOOD ENGINE DISABLE PLUG OPERATION

This chipper hood engine disable plug is installed for safety purposes. It is designed to shut down the engine if the hood pin is not properly in place holding the chipper hood in the closed position. The system must be correctly maintained and operative at all times. If the plug connector is not correctly installed the engine will not start or run.

The chipper hood engine disable plug is located on top of the chipper hood (see figure 1). The chipper engine disable plug is made up of two parts: an electric socket and a plug connector (see figure 2). The electric socket is bolted to the chipper engine disable plug mount bracket (see figure 3) and the plug connector is attached by a cable to the hood pin (see figure 4).

If the chipper engine disable plug is not properly installed then the engine will not start or run. If the chipper engine disable plug becomes disconnected while the chipper engine is running the engine will be shut down or be disabled from running. This is for safety purposes, to ensure that the hood pin is not removed and the chipper hood is not opened while the engine is running.

The chipper engine disable plug is wired to shut down the chipper engine. When the plug connector is pulled out of the electric socket the electric circuit is broken, disabling the engine.

NOTICE

The engine disable plug has a circuit fuse. If the engine will not start or run, check the fuse first before consulting the engine manufacturer's manual. Circuit fuse locations: CAT / Perkins- located at the "BATT" wire near the ignition switch, Cummins- located by engine manufacturer near the starter (wires labeled "POW"), John Deere- located by engine manufacturer "Short Stop" circuit breaker by the ignition switch on the instrument panel or fuse by the ECM, and Deutz, Hatz, Honda, Kohler, and Robin- located at the battery post on the starter.

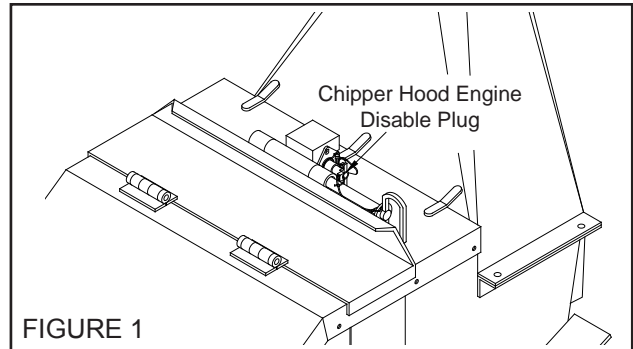

FIGURE 1

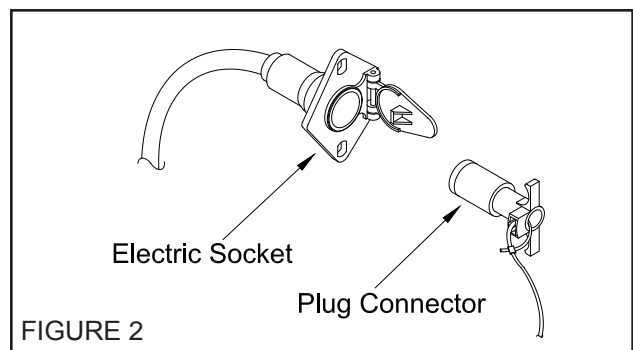

FIGURE 2

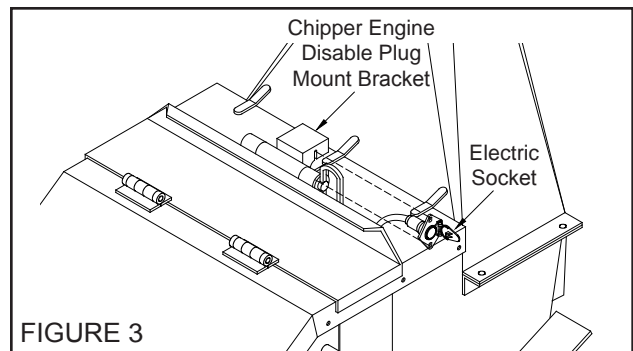

FIGURE 3

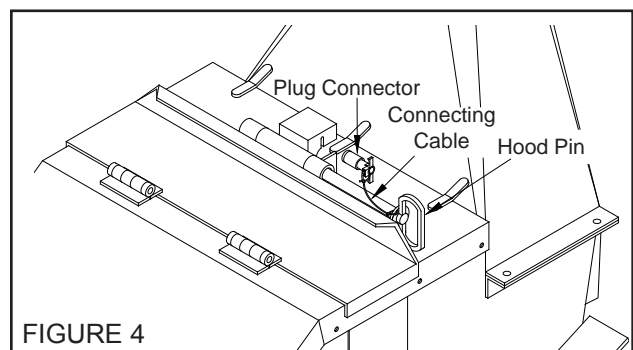

FIGURE 4

CONSULT THE ENGINE MANUFACTURER’S MANUAL FOR SPECIFIC CONTROLS, OPERATION, & MAINTENANCE FOR TYPICAL ENGINES

- 1) **Ignition Switch:**
Turn the ignition switch key clockwise one stop (on position) to turn the electrical system on. The key should remain in the on position while the engine is running. Turn the key fully clockwise (start position) this will start the engine. To shut off the engine, return the key to the off position.
- 2) **On/Off Switch - Push Button Start:**
Some gasoline engines may have a Toggle Switch or an On/Off Switch combined with a push button to start the engine. First turn the On/Off Switch or Toggle Switch to the on position, then depress and hold the Push Button Start until the engine starts, then release the button. To shut off the engine, return the On/Off Switch or Toggle Switch to the off position.
- 3) **Ignition Switch With Preheat:**
The typical diesel engine may have a preheat system to assist in starting the engine during cold weather. To activate the preheat system, continue to hold the ignition key in the preheat position for 15 to 20 seconds, then attempt to start the engine. If the engine fails to start within 15 seconds, return the key to the preheat position, hold 10 seconds, and try starting again.
- 4) **Choke Adjustment (if equipped):**
Some gasoline engines may have a choke adjustment, pull the choke lever out to choke the engine. Push the choke lever in for normal engine operations.
- 5) **Throttle Adjustment (if equipped):**
Some engines may have a knob or a handle for the throttle adjustment. Typically you would pull the knob out, or turn the handle to increase the engine R.P.M.'s. To decrease you would push in the knob or turn the handle the opposite way.
- 6) **“Bandit” Lever Lock Cable Throttle System (if equipped):**
The Bandit throttle system has (2) positions, HIGH and LOW. Engine R.P.M. is controlled by moving the lever from one position to the other.
- 8) **Push Button Or Electric Throttle System (if equipped):**
Some engines may have a push button or electric throttle adjustment. Engine R.P.M. is controlled by pushing a button or switch to raise or lower the R.P.M.
- 9) **Alternator Warning Light:**
This light will glow when the alternator is not charging, or when the ignition switch is turned on and the engine is not running.
- 10) **Oil Pressure Warning Light:**
This light will glow when the oil pressure is to low, or when the ignition switch is turned on and the engine is not running.
- 11) **Engine Temperature Warning Light:**
This light will glow when the engine, or engine coolant, is above normal operating temperature. If this occurs allow the engine temperature to cool down. If the engine is overheating because of a loss of coolant, or a broken fan belt, shut the engine off immediately.

TYPICAL DIESEL ENGINES

TYPICAL GASOLINE ENGINE

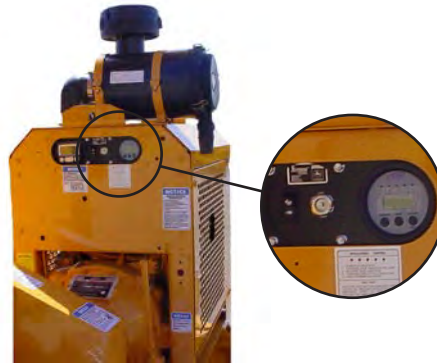
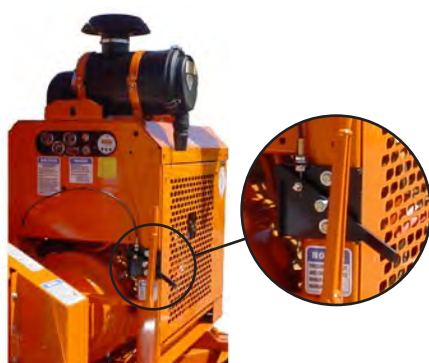

BANDIT THROTTLE SYSTEM

PUSH BUTTON OR ELECTRIC THROTTLE SYSTEM

Bandit

Transportation Procedures

WARNING

BEFORE TRANSPORTING THE MACHINE THE FOLLOWING MUST BE COMPLETED.

- 1) Idle engine, disengage clutch.
- 2) Make sure the feedwheel is in the lowered position.
- 3) Place all hydraulic controls in the "off" position.
- 4) Turn off engine, wait for the chipper disc/drum to come to a complete stop and you must have the ignition key in your possession.
- 5) Remove all excess debris. Remove any wood or debris which may have collected.
- 6) Return wooden push paddle to the mount and secure for transportation. Store all tools in the tool box and make sure all boxes and cabinets are closed and secured.
- 7) If equipped, close the folding infeed pan for the infeed hopper and make sure the spring latches are locked into place.
- 8) Raise the front of the machine or transport trailer with the tongue jack and remove the stabilization blocks used. If the machine is equipped with a hydraulic tongue jack, remove the lock pin before raising the front of the machine.
- 9) Couple machine or transport trailer to transport vehicle by lowering the machine onto the hitch. Make sure the hitch matches the coupling size. Then secure hitch and lock it.
- 10) Place the tongue jack in the transport position. If the machine is equipped with a hydraulic tongue jack, lift the foot pad to the transport position and install the lock pin.
- 11) Attach the safety chains by crossing them under hitch, make sure to allow the proper amount of slack in chains to avoid binding or dragging the ground when making turns.
- 12) Connect the brake breakaway cable (if equipped) and plug in the electrical connection for the lights on the machine or transport trailer.
- 13) Check running lights, turn signals, and brake lights. All must be operating properly before transporting the machine. Also check brakes (if equipped) to make sure they are operating correctly.
- 14) Do not transport unless discharge is clamped, pinned and bolted securely into place in the transport position pointed over the tongue.
- 15) If machine is equipped with a chip box, lock the turntable in the transport position.
- 16) Check tires for correct pressure, cuts or damaged rims.
- 17) Check lug nuts and retorque if necessary. Check new units before operation, check again after 20-25 miles (32-40 km) and regularly check at least weekly.
- 18) Inspect and replace any axle dust caps that are damaged or leaking.
- 19) Check wheel bearings and grease or oil axles per axle manufacturer's manual.
- 20) Walk around the machine to confirm that everything is secure and that there is not anything loose that could fall off during transport. Look under machine to ensure nothing is dragging. Look down both sides of the machine for anything sticking out that may become damaged during transport.
- 21) If machine is equipped with a vise, make sure to secure in place and clamp jaws closed.
- 22) Close and secure any of the following, if equipped: engine cowl doors and side panels, radiator debris screens, inspection doors, housing covers, tanks caps and covers, etc.
- 23) If the machine is self propelled and on a transport trailer, make sure the trailer has the correct load capacity, the machine is positioned on the trailer for correct weight distribution, and the machine is securely bound down to the trailer bed per your States binding requirements. Make sure the loading ramps are securely stored for transport. (See Loading & Unloading Self-Propelled Machines.)
- 24) The machine is now ready for transport. Make sure to obey all local regulations and laws regarding the transporting of this type of machine.
- 25) Do not drive too fast for road conditions or exceed speed regulations for equipment towing. Machine must be hauled level and the towing vehicle must be sized to handle hitch weight, towing weight, and braking requirements.

Loading & Unloading Self-Propelled Machines

WARNING

BEFORE ATTEMPTING TO USE A TRAILER FOR TRANSPORT, MAKE SURE THE TRAILER TOWING VEHICLE IS APPROPRIATE FOR THE TASK.

- 1) The trailer has a cargo weight rating capacity for the weight of the machine. The combined weight of the trailer and the machine can not exceed the load capacity of the tires, axles, hitch coupler system or the GVWR (Gross Vehicle Weight Rating) of the trailer.
- 2) The trailer must have a lighting system and a braking system to match and perform correctly off the towing vehicle's system. You must meet the Federal and your States' Department of Transportation Code of Regulations concerning lights, brakes, and highway transit.
- 3) Make sure the towing vehicle has the hauling and hitch capacity ratings for the trailer and machine combination. The towing vehicle must be mechanically sound and capable of handling the towing job.
- 4) The trailer should be constructed with appropriate chain down positions for the specific sized machine. You must have binders that will withstand the strain of the machine trying to move while it is being transported.
- 5) When the machine is positioned on the trailer bed, there should be about 15% of the total trailer package weight on the tongue or hitch.
- 6) The loading ramps or loading gate of the trailer must be constructed to withstand the weight and forces involved in loading and unloading the machine.

WARNING

BEFORE LOADING OR UNLOADING THE MACHINE INSPECT AND CONFIRM THE FOLLOWING STEPS: When loading or unloading the self-propelled machine on the trailer, use care and caution. The maneuvering of the equipment must be slow, smooth, and intentional, not fast and jerky.

- 1) Make sure the trailer and towing vehicle are parked on a flat surface. They must be stable on the surface with the brakes locked and/or the wheels chocked to avoid unwanted movement.
- 2) Position the loading ramps or loading gate securely between the trailer and the ground level. Have them located so that they are in line with the tires or tracks of the machine when it moves.
- 3) Remove and store the chains and binders used for transporting.
- 4) Confirm that there are not any obstacles on the trailer bed, around the trailer that may cause restricted movement of the machine or the operator.
- 5) The only person in the area should be the one that is operating the machine controls, and he/she should be very experienced with the controls on this machine.
- 6) If you are on streets, roads or public areas, position the warning cones etc, per your company's safety policy.
- 7) Follow all pre-startup instructions for the machine.
- 8) Typically, the engine end of the machine should be positioned so that it is toward the tongue of the trailer, during transport.
- 9) Align the machine with the trailer bed, and the loading ramps. The only equipment movement should be slowly, straight on or straight off the trailer.
- 10) With the engine and the machine at as low a speed as possible, move the machine toward the ramp system. Make sure the alignment is correct throughout the travel.
- 11) Properly secure the equipment and the area to avoid any possible accidents or dangers.

MAINTENANCE SECTION

The Bandit is a very simple machine to maintain. If you will follow a regular scheduled preventative maintenance program you should have years of trouble free operation.

⚠ DANGER

Before attempting any type of maintenance disengage clutch, turn off engine, wait for the disc/drum to come to a complete stop, install the disc/drum lock pin, disconnect battery, and make sure the ignition key is in your possession.

⚠ DANGER

Do not let anyone operate or maintain this machine until they have thoroughly read this manual, reviewed the equipment decals, watched the equipment video, and has been properly trained. You can purchase additional Bandit manuals, decals and videos for a nominal fee.

NOTICE

Consult your engine manual for proper break-in procedures. Various engines require somewhat different procedures, but basically the engines need to operate at lower R.P.M.'s and loads for a specific time.

NOTICE

Failure to properly break-in your engine may result in poor bearing and piston ring surfaces.

NOTICE

The Bandit has only been run for a short time to test proper hydraulic pressures, possible leaks, etc. The fuel tank will be empty. Fuel is provided through a small auxiliary tank for testing. This immensely helps maintain safety in our manufacturing facility and while shipping.

NOTICE

Expensive damage to the Bandit will occur if proper preparation is not taken before welding on the machine. Be sure to disconnect both battery cables and the engine ECM (engine control module) before welding. Follow the specific Engine MFG. instructions for proper welding and grounding procedures, before attempting to weld on the machine. If welding on the machine, do not ground the welder through the machine bearings, ground near work to be performed.

DAILY START UP & MAINTENANCE

1) Check the safety decals and engine gauges:

Replace any missing or damaged decals and/or engine gauges.

2) Check all safety equipment:

Check for proper operation. Repair or replace as needed. With everything shut down and stopped, insure last chance cables freely operate feed control valve.

3) Check entire machine for loose bolts, nuts, parts, or components:

Check entire machine for any loose parts or components. Check for loose nuts or bolts. Torque, tighten, or replace any of the loose components. See page 41 for specific bolt torques.

4) Check all guards:

Check to make sure all guards are in place and installed correctly. Make sure they are secure.

5) Check chipper hood hinge:

Make sure the hood hinge operates correctly, and is lubricated. Must replace hinge if damaged.

6) Checking for foreign objects:

Before opening the hood make sure the clutch is disengaged, the engine off, the disc/drum lock pin is installed, battery is disconnected, and also make sure the ignition key is in your possession. Remove the hood pin padlock, disconnect the chipper hood engine disable plug, suppress the spring lock for hood pin on disc chippers, and then remove the hood lock pin. Look for any foreign objects inside the chipper housing. Remove any foreign objects found.

Bandit

DAILY START UP & MAINTENANCE (cont.)

7) Check chipper drum assembly:

Check for the condition of knife bolt threads, secure welds, torqued bolts, excessive wear and impact cracks. If a problem is found contact the chipper manufacturer or an authorized Bandit dealer. Also check the chipper housing at this time. Check the chipper base, belly band, and hoods for wear or damage. Also inspect the chipper bearings.

8) Check chipper disc/drum to turn:

Very carefully, manually with a pry bar or wood bar, turn the chipper disc/drum a full revolution. This is to ensure the anvil and knives have proper clearance. If the chipper disc/drum is jammed with debris or frozen in place, DO NOT attempt to start the engine and engage clutch until the chipper disc/drum rotates freely.

9) Check the condition of your fan blades, knives, anvil, and attaching hardware:

Grind, file, or replace your knives to keep them sharp. Check the fan blades, anvil, and attaching hardware for the knives and anvil. Replace if necessary.

10) Properly torque the knife mounting hardware:

All knife mounting hardware must be factory approved. Knife mounting hardware must be replaced after maximum of 4-5 knife rotations/changes to insure safe clamping ability.

Torque set, AT ALL TIMES to: 180 ft-lbs (245 Nm)

11) Hood lock pin and padlock:

After closing chipper hood, reinsert the hood pin and padlock, make sure pin is tight and secure. If worn replace immediately. Don't use a worn or makeshift hood pin. Make sure the spring lock for the hood pin is in the correct position on disc chippers. Make sure the chipper hood engine disable plug is installed correctly and that it is also operating properly.

12) Grease all feedwheel and chipper bearings daily:

Use an EP-2 Lithium type grease only for all bearings. Purge chipper bearings with grease. You can not over grease these bearings. Grease feedwheel bearings with one shot of grease. Both types of bearings are designed with a relief system that will not allow over greasing. In other words, you can not hurt the bearing seals by pumping in too much grease. Most of the failures related to bearings are diagnosed as "Contamination". Contamination is caused by improper lubrication. Wipe off excess grease. **Excessive grease will attract dirt.**

13) Check / adjust the chipper drive belt tension:

The belts will need to be tightened several times in the first few days of operation. A loose belt will slip and then glaze over. Once they slip you must replace them. Check hydraulic pump drive belts also if equipped. See pages 44-45 for procedures.

14) Check the hydraulic pump and motor shafts:

Check the hydraulic pump and hydraulic motor shafts for fit and tightness.

15) Check hydraulic oil level:

The hydraulic oil reservoir tank level should always remain at 7/8 full. Remember to check DAILY to avoid excessive heat build up.

16) Check for any fluid leaks:

Inspect for any oil, fuel, hydraulic oil, or engine coolant leaks. Check all hoses, fittings, lines, and tanks. DO NOT use fingers or skin to check for hydraulic leaks. Repair or replace any damaged or leaking components.

17) Check hydraulic control valves:

Inspect all hydraulic control valves and insure they operate smoothly and shift correctly.

18) Check the fuel level:

Check the fuel level, running out and repriming is time consuming. Do not over fill, and you must leave fuel expansion space in the top of the tank.

19) Check engine oil and coolant level:

Follow the engine manufacturer manual recommendations for fluid levels. You MUST follow specific ENGINE MFG. manual recommendations for radiator coolant, additives, lubrication, correct engine speed, ETC.

20) Check radiator, debris screen:

Thoroughly clean radiator fins at least once a day and twice in excessive conditions. Make sure debris is not packed between fins. Use pressurized water spray to clean. Do not rely on air pressure. The radiator will only appear to be clean. A partially plugged radiator will not allow the engine to cool properly. Clean cooling fan, shroud on air cooled engines, and the debris screen (if so equipped). Improper service, maintenance, or neglect will cause overheating problems and engine failure.

DAILY START UP & MAINTENANCE (cont.)

21) Check air cleaner or precleaner:

Clean or replace element following engine manual recommendations.

22) Check clutch:

Check for proper lubrication, and engagement tension adjustment, frequently adjust and lubricate per PTO clutch manufacturer's manual. Bandit Industries, Inc. does not warranty clutch failures.

23) Check tires:

Check tires for wear, weather checking and damage. Replace if damaged.

24) Inspect axle dust caps:

Inspect axle dust caps and replace if damaged or leaking.

25) Check the infeed hopper:

Check in the infeed hopper for any foreign objects and around the entire machine for tools, cans, saws, etc. All tools not in use should be stored in a tool box.

26) Block the tires and tongue:

Before operation block the tires and tongue for stability. Do not rely on tongue jack for operational stabilization.

27) Check the discharge direction:

Remove transport bolt and nut, then make sure the discharge is pointed in a safe direction and locked into place.

28) Review all safety procedures on decals, from manual, and from video.**29) Make sure all safety equipment is being worn:**

Hard hat, gloves, eye protection, ear protection, etc.

30) Remember to check EVERYTHING on the checklist.

WEEKLY MAINTENANCE

1) Check anvil clearance, tightness, and wear:

Measure the anvil clearance. The clearance should be .120" (3.0 mm) from highest knife. Check the anvil hardware, make sure the bolts are at the proper tightness. The anvil is a normal wear item, if it is worn you can rotate it to a new working edge. Refer to page 47 for the exact checking of anvil clearance procedure.

2) Check alternator and fan belts on engine:

As applicable adjust and maintain per the engine manufacturer's manual.

3) Check spring tension on feedwheel system:

Do not over tighten. Keep tight for small diameter material and progressively looser for larger diameter material. See page 46.

4) Check wheel lug nuts:

Keep lug nuts tight, retorque, replace if needed.

5) Check and retighten tank mount bolts:

Check and retighten the fuel tank and hydraulic tank mount bolts.

6) Lubricate all pivoting and hinged areas:

Lubricate all pivoting and hinged areas on the machine (i.e. control handle, discharge flipper, etc.)

7) Lube chain driven components:

Use a dry lube on any chain driven components: hydraulic swivel discharge and chain driven feedwheels.

8) Check and oil feedwheel slide box:

Check that feedwheel slide box is working smoothly, oil with 10W/30 type motor oil. Especially new machines need oiling to ensure correct operation during break-in.

MONTHLY MAINTENANCE

1) Check towing hitch:

Check for excessive damage or wear. Replace if needed. Keep pintle ring greased to reduce wear.

2) Check discharge and infeed hopper wear:

Check for wear on discharge, infeed hopper, and discharge direction adjustor; build up, repair or replace as needed.

3) Inspect feedwheel motor connections:

Check and maintain correct torque, on feedwheel motor connections. See page 48.

4) Check feedwheel teeth for sharpness:

Replace if needed.

5) Check chipper bearings and chipper sheave:

Check, retighten all bearing bolts, bearing lock collars, and also belt sheave bushings to correct torques.

6) Tire air pressure:

Fill each tire to rated capacity on tire.

7) Check hydraulic function pressures:

Check, reset and maintain all hydraulic function pressure settings to a maximum of the specified PSI (bar). This will give you the best performance from the hydraulic system.

8) Check wheel bearings:

Check and grease or oil wheel bearings per axle manufacturer's instructions.

9) Check and adjust brakes:

Check and adjust brakes as needed per axle MFG. manual.

10) Lubricate "Bandit" lever throttle cable:

If the machine is equipped with a "Bandit" lever throttle system, lubricate inner throttle cable and cable ends with a cable lube or SAE 10W/30 oil. Replace throttle cable if it doesn't operate smoothly.

3 MONTH MAINTENANCE

1) Hydraulic oil filter(s):

Must be replaced after FIRST 10 HOURS OF OPERATION, USE A 10 MICRON FILTER, then quarterly or every 400 hours afterwards.

3) High pressure oil filter(s) (if equipped):

Must be replaced after FIRST 10 HOURS OF OPERATION, then quarterly or every 400 hours afterwards.

2) Grease discharge swivel plates:

Grease swivel plates for discharge as needed.

YEARLY MAINTENANCE

1) Hydraulic oil:

Change hydraulic oil and flush the hydraulic reservoir tank.

2) Hydraulic suction screen(s):

Change hydraulic suction screen(s) yearly or every 2000 hours.



MAINTENANCE SECTION

BOLT TORQUE CHART (THESE TORQUES ARE BASED ON DRY, CLEAN THREADS)			
DESCRIPTION	BOLT SIZE	TORQUE (FT.-LBS.)	TORQUE (Nm)
Chipper Bearing Bolts	3/4" - 10 NC	220	298
Drum Head Shaft Bushing "4040"	5/8" - 11 NC	142	193
Anvil	1/2" - 13 NC	75	102
Knife Bolts	5/8" - 11 NC	180	245
Feedwheel Bearing Bolts	1/2" - 13 NC	75	102
Feedwheel Bearing Set Screws	3/8" - 24 NF	20	27
Grip-Tight Feedwheel Bearing Set Screws		2	3
Engine Hold Downs	1/2 - 13 NC	60	81
Engine Hold Downs	5/8" - 11 NC	125	169
"RE" Hydraulic Feedwheel Motor Shaft Nut	1" - 20 NEF	250 - 300	339 - 407
Engine Sheave Bushing "SF"	3/8" - 16 NC	30	41
Engine Sheave Bushing "E"	1/2" - 13 NC	60	81
Chipper Sheave Bushing "E"	1/2" - 13 NC	60	81
Chipper Sheave Bushing "F"	9/16" - 12 NC	75	102
Autofeed Cartridge Nut		4 - 6	5 - 8
Autofeed Plus Solenoid Retainer Nut		4 - 6	5 - 8
Hitch Mount Bolts	5/8" - 11 NC	220	298

Before tightening bolts be sure you have the correct size bolt for the correct amount of torque.
Use only factory approved knives and hardware.

<u>BASIC WHEEL TORQUE REQUIREMENTS (per mfg.)</u>	
KEEP LUG NUTS PROPERLY TIGHTENED, CHECK NEW UNIT BEFORE OPERATION, CHECK AGAIN AFTER 20-25 MILES (32-40 km) AND REGULARLY CHECK AT LEAST WEEKLY.	
5 & 6 Lug Hubs (1/2" - 20 Studs)	90 - 120 ft.-lbs. Torque (122 - 163 Nm)
8 Lug Hubs (1/2" - 20 Studs)	90 - 120 ft.-lbs. Torque (122 - 163 Nm)
8 Lug Hubs (9/16" - 18 Studs)	110 - 120 ft.-lbs. Torque (149 - 163 Nm)
8 Lug Hubs (5/8" - 18 Studs)	190 - 210 ft.-lbs. Torque (258 - 285 Nm) (Cone Nut)
8 Lug Hubs (5/8" - 18 Studs)	275 - 325 ft.-lbs. Torque (373 - 441 Nm) (Flange Nut)
10 Lug Hubs (3/4" - 16 Studs)	450 - 500 ft.-lbs. Torque (610 - 678 Nm)
(Consult axle manufacturers manual shipped with each machine for specific axle-stud-wheel combination lug nut torques.)	

DAILY START UP & MAINTENANCE CHECK LIST

Each day before starting your machine these checks must be made:

	O.K.	Repaired
1) Check the safety decals and engine gauges, replace if damaged.	<input type="checkbox"/>	<input type="checkbox"/>
2) Check, maintain, and service all safety equipment for proper operation: “Last Chance Stop” system, engine disable plug, control bar, hood pin, spring lock for hood pin (disc chippers only), pusher tool, etc.	<input type="checkbox"/>	<input type="checkbox"/>
3) Check entire machine for loose nuts, bolts, and components.	<input type="checkbox"/>	<input type="checkbox"/>
4) Check all guards to make sure they are tight and securely in place.	<input type="checkbox"/>	<input type="checkbox"/>
5) Make sure hood hinge operates correctly, is not damaged, and is lubricated.	<input type="checkbox"/>	<input type="checkbox"/>
6) Open chipper hood and check for any foreign objects.	<input type="checkbox"/>	<input type="checkbox"/>
7) Check the condition of chipper disc/drum assembly.	<input type="checkbox"/>	<input type="checkbox"/>
8) Carefully rotate the chipper disc/drum with a pry bar or wood bar to insure proper anvil clearance. If chipper disc/drum is jammed with debris or frozen in place, do not attempt to start engine and engage clutch until chipper disc/drum rotates freely.	<input type="checkbox"/>	<input type="checkbox"/>
9) Check the condition of your fan blades, knives, anvil, and attaching hardware.	<input type="checkbox"/>	<input type="checkbox"/>
10) Properly torque knife mounting hardware.	<input type="checkbox"/>	<input type="checkbox"/>
11) After closing chipper hood, reinsert the hood pin and padlock, make sure the hood pin is tight and secure. Make sure the hood lock pin is firmly in place, the spring lock for hood pin springs back into position on disc chippers, and the chipper hood engine disable plug is installed correctly.	<input type="checkbox"/>	<input type="checkbox"/>
12) Grease chipper bearings (purge) and feedwheel bearings (1 shot) daily.	<input type="checkbox"/>	<input type="checkbox"/>
13) Check and/or adjust belt tension on chipper and hydraulic pump belt drives.	<input type="checkbox"/>	<input type="checkbox"/>
14) Check hydraulic pump and motor shafts for fit and tightness.	<input type="checkbox"/>	<input type="checkbox"/>
15) Check and always maintain hydraulic level at 7/8 full.	<input type="checkbox"/>	<input type="checkbox"/>
16) Check all hoses, fittings, lines, and tanks for damage and fluid leaks.	<input type="checkbox"/>	<input type="checkbox"/>
17) Check hydraulic control valves and insure they operate and shift correctly.	<input type="checkbox"/>	<input type="checkbox"/>
18) Check fuel level. (Running out and repriming is time consuming).	<input type="checkbox"/>	<input type="checkbox"/>
19) Check engine oil, coolant levels, and correct engine speed. Follow ENGINE MANUFACTURER’S manual specs.	<input type="checkbox"/>	<input type="checkbox"/>
20) Check radiator and debris screen. Clean as necessary. Clean cooling fan and shroud on air cooled engines.	<input type="checkbox"/>	<input type="checkbox"/>
21) Check air cleaner and precleaner. Clean as necessary.	<input type="checkbox"/>	<input type="checkbox"/>
22) Check clutch for proper engagement tension and lubrication, frequently adjust and grease per PTO manufacturer’s manual recommendations.	<input type="checkbox"/>	<input type="checkbox"/>
23) Check condition of the tires.	<input type="checkbox"/>	<input type="checkbox"/>
24) Inspect and replace any axle dust caps that are damaged or leaking.	<input type="checkbox"/>	<input type="checkbox"/>
25) Check infeed hopper and around the entire machine for any foreign objects, tools, cans, saws, etc.	<input type="checkbox"/>	<input type="checkbox"/>
26) Block tires and tongue for stability before operation. Do not rely on tongue jack.	<input type="checkbox"/>	<input type="checkbox"/>
27) Remove transport bolt and nut, then make sure discharge is pointed in safe direction and locked into place.	<input type="checkbox"/>	<input type="checkbox"/>
28) Review all safety procedures on decals, from manual, and from video.	<input type="checkbox"/>	<input type="checkbox"/>
29) Wear all applicable safety equipment: hard hat, gloves, eye protection, ear protection, etc.	<input type="checkbox"/>	<input type="checkbox"/>
30) Remember to check EVERYTHING on the checklist.	<input type="checkbox"/>	<input type="checkbox"/>

Bandit

WEEKLY CHECK LIST

	O.K.	Repaired
1) Check anvil clearance, tightness, and wear.	<input type="checkbox"/>	<input type="checkbox"/>
2) Check alternator and fan belts on engine.	<input type="checkbox"/>	<input type="checkbox"/>
3) Check spring tension on easy climb system.	<input type="checkbox"/>	<input type="checkbox"/>
4) Check and retighten wheel lug nuts.	<input type="checkbox"/>	<input type="checkbox"/>
5) Check and retighten fuel tank and hydraulic tank mount bolts.	<input type="checkbox"/>	<input type="checkbox"/>
6) Lubricate pivoting and hinged areas (i.e. control handle, discharge flipper, etc.)	<input type="checkbox"/>	<input type="checkbox"/>
7) Use a dry lube on any chain driven component.	<input type="checkbox"/>	<input type="checkbox"/>
8) Check feedwheel slide box is working smoothly and oil.	<input type="checkbox"/>	<input type="checkbox"/>

MONTHLY CHECK LIST

	O.K.	Repaired
1) Check towing hitch for wear, keep pintle ring greased.	<input type="checkbox"/>	<input type="checkbox"/>
2) Check discharge, and infeed hopper for wear.	<input type="checkbox"/>	<input type="checkbox"/>
3) Inspect feedwheel motor connection.	<input type="checkbox"/>	<input type="checkbox"/>
4) Check feedwheel teeth for sharpness.	<input type="checkbox"/>	<input type="checkbox"/>
5) Check, retighten all bearing and chipper sheave bolts.	<input type="checkbox"/>	<input type="checkbox"/>
6) Check and fill tires to rated pressure.	<input type="checkbox"/>	<input type="checkbox"/>
7) Check hydraulic function pressures. Set to specified PSI (bar).	<input type="checkbox"/>	<input type="checkbox"/>
8) Check and grease or oil wheel bearings, follow axle MFG. instructions.	<input type="checkbox"/>	<input type="checkbox"/>
9) Check and adjust brakes, follow axle MFG. instructions.	<input type="checkbox"/>	<input type="checkbox"/>
10) Lubricate "Bandit" lever throttle cable.	<input type="checkbox"/>	<input type="checkbox"/>

3 MONTH CHECK LIST

	O.K.	Repaired
1) Replace hydraulic filter(s) after first 10 hours then quarterly or every 400 hours.	<input type="checkbox"/>	<input type="checkbox"/>
2) Grease swivel plates for discharge as needed.	<input type="checkbox"/>	<input type="checkbox"/>
3) Replace high pressure oil filter(s) (if equipped) after first 10 hours then quarterly or every 400 hours.	<input type="checkbox"/>	<input type="checkbox"/>

YEARLY CHECK LIST

	O.K.	Repaired
1) Change hydraulic oil and flush the hydraulic tank.	<input type="checkbox"/>	<input type="checkbox"/>
2) Replace hydraulic suction screen(s) annually or every 2000 hours.	<input type="checkbox"/>	<input type="checkbox"/>

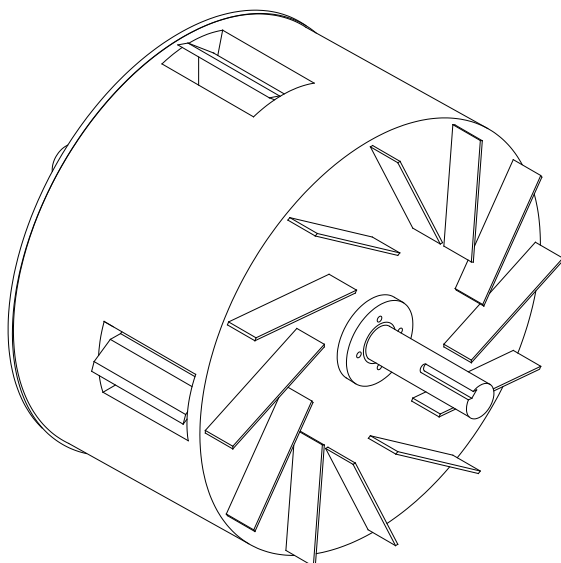

⚠ WARNING

WHEN YOU CHANGE CHIPPER KNIVES

CHECK CHIPPER DRUM ASSEMBLY FOR CONDITION OF KNIFE BOLT THREADS, SECURE WELDS, TORQUED BOLTS, EXCESSIVE WEAR AND IMPACT CRACKS. IF PROBLEM FOUND CONTACT CHIPPER MANUFACTURER, OR AUTHORIZED CHIPPER DEALER.

BELT TENSION

GENERAL RULES FOR TENSIONING

1. Check tensioning during the first 2 through 48 hours of run-in operation especially.
2. Over tensioning or under tensioning shortens belt and bearing life.
3. Keep belts free from foreign materials that may cause the belt to slip.
4. Make V-drive inspection on a periodic basis. Never use belt dressing as this will damage the belt and cause early failure.
5. Belts should never be forced over the sheave. Allow enough room for belts to slip on.
6. Always make sure sheaves are aligned properly.

TENSIONING PROCEDURE

Main Drive Belts

Follow all pre-maintenance shut down procedures. Locate the center of the belt span between the sheaves. Push or pull on the belt until the belt has deflected 3/8" (9.5 mm). Record the push or pull force. The force should be 22 to 24 lbs./belt (10.0 to 10.9 kg/belt). Adjust the belt tension if the force falls outside of this range. If belts are not properly adjusted belts will slip, glaze over, and be ruined. This is NOT covered by warranty.

- 1) Remove beltshield.
- 2) To adjust the belt tension, loosen the four engine mounting bolts and the jam nuts on the engine adjuster on the radiator end of the engine.
- 3) Adjust the belt tension with the engine adjuster on the clutch end of the engine. If you have to push the engine with the adjuster, the belts will tighten slightly after the engine is realigned.
- 4) Use the engine adjuster on the radiator end of the engine to realign the engine, so the engine sheave and chipper sheave are aligned. The sheaves can be checked with a string or straight edge.
- 5) Torque the two engine mounting bolts (see Torque Chart for the correct torque) on the opposite side of the engine from the engine adjusters.
- 6) Loosen the jam nuts on the engine adjuster on the radiator end of the engine.
- 7) Torque the engine mount bolt and then tighten the engine adjuster jam nuts on the radiator end.
- 8) Hand tighten the remaining engine mount bolt and loosen the engine adjuster jam nut on the clutch end half a rotation. Loosen the engine adjuster jam nuts all the way and torque the engine mount bolt.
- 9) Tighten the engine adjuster jam nuts on the clutch end.
- 10) Recheck the belt tension and alignment, if readjustment is needed go back to step 2.
- 11) Reinstall beltshield.

NOTE: lbs./belt (kg/belt) is per 1 belt. If equipped with 4 groove poly band belt, lbs./belt (kg/belt) must be multiplied by 4. If equipped with two 3 groove poly band belts, lbs./belt (kg/belt) must be multiplied by 3 for each poly band belt.

NOTE: It is a good practice to rotate the belts during tensioning. Then recheck deflections. The belts may need to be tightened again.

Pump Drive Belts (If equipped)

- 1) Locate the center of the span between sheaves.
- 2) Push or pull down on the belt until the belt has deflected 1/4" (6.4 mm).
- 3) Record push or pull down force. The force should be 12 lbs (5.4 kg).
- 4) Adjust the belt tension if the force falls outside of this range.

Do not over tighten the hydraulic pump belt. For best results use a good belt tension tester. Most all pump failures result from too much side load on the pump shaft. Too much belt tension is very easy to detect inside a failed pump. Pumps with this condition will not be covered under warranty.

DO NOT IGNORE THIS MAINTENANCE RULE!

New belts stretch very soon and must be adjusted several times in the first few hours of operation. Adjust after one hour of operation, then every four hours until the belts quit stretching.

Failure to do this will cause the belts to burn and fly off. **THIS FAILURE IS NOT COVERED BY WARRANTY!**

BELT TENSION

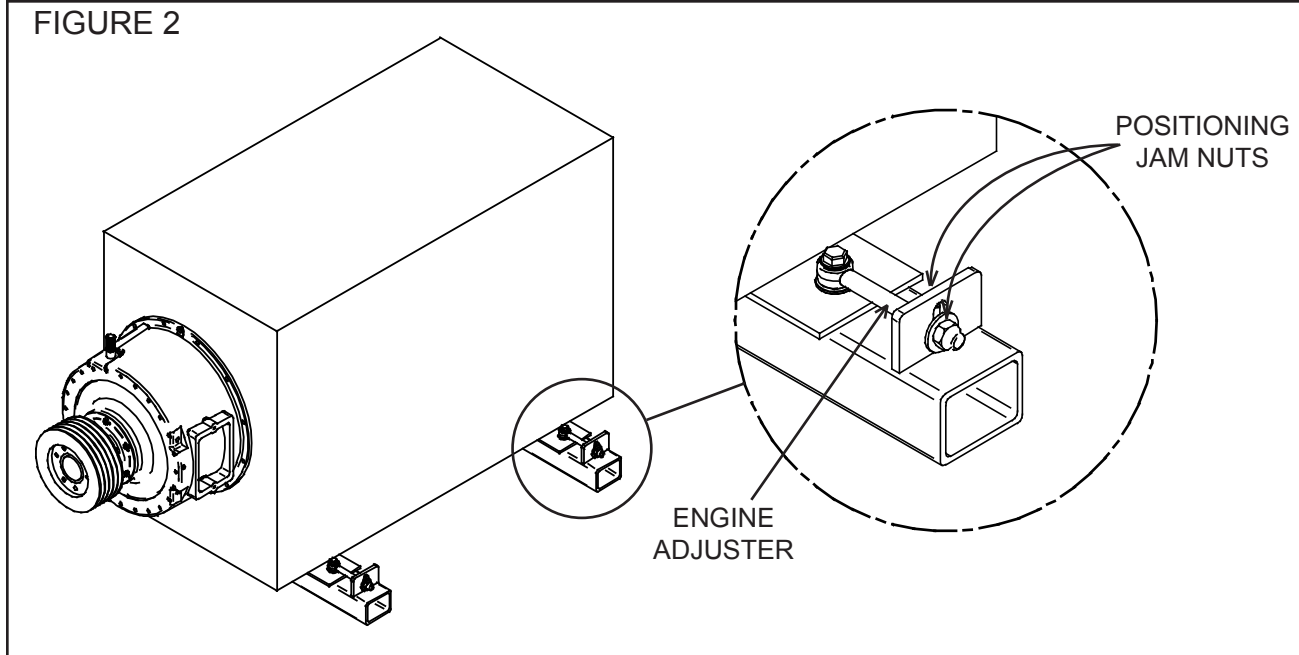
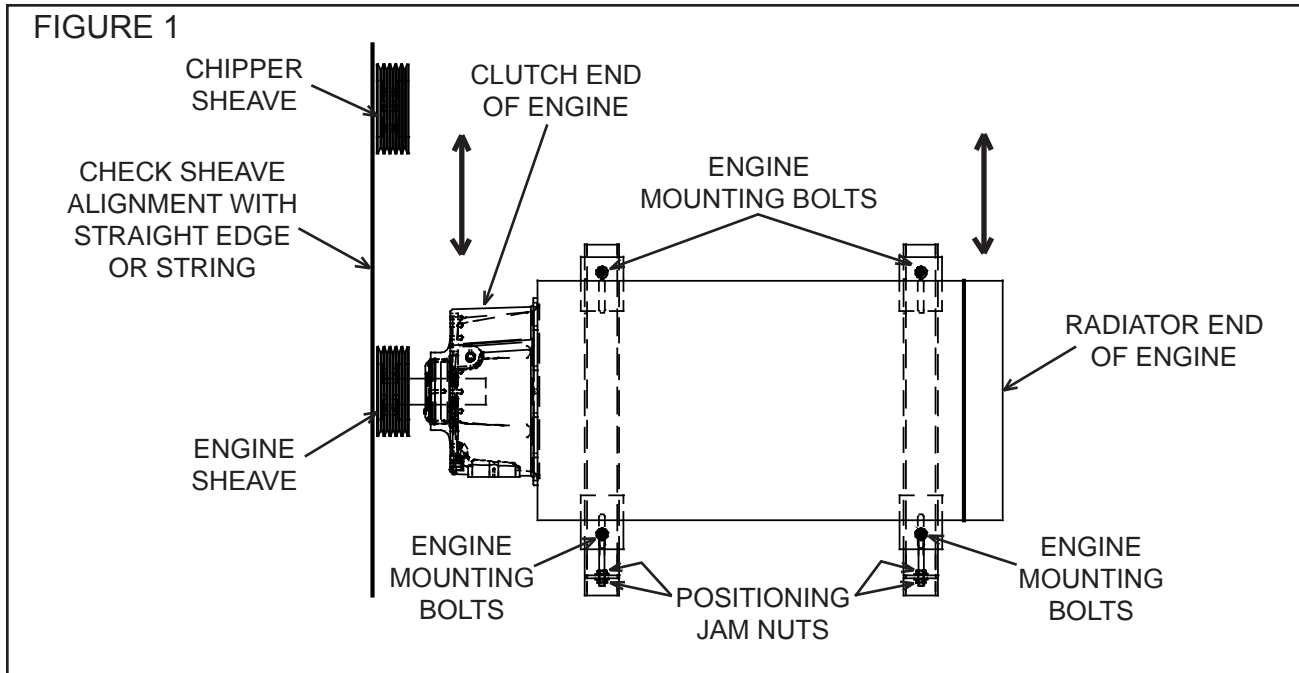

Worn or misaligned belts and sheaves in the power train causes belt slippage, thus power loss. Keep the power train working for you, not against you, by checking for needed adjustment or replacement.

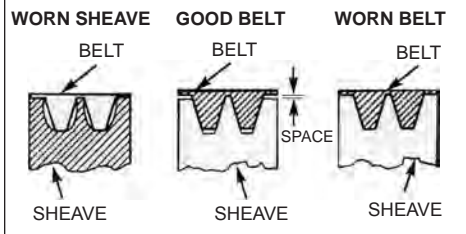

Main Drive belts maximum of 3/8" deflection with 22 to 24 lbs. of force.
 Pump Drive belts maximum of 1/4" deflection with 12 lbs. of force.

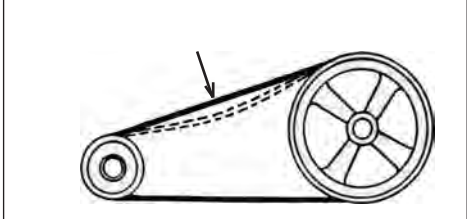

EASY CLIMB FEED SYSTEM

⚠ DANGER

Before attempting any type of maintenance disengage clutch, turn off engine, wait for the disc/drum to come to a complete stop, install the disc/drum lock pin, disconnect battery, and make sure the ignition key is in your possession.

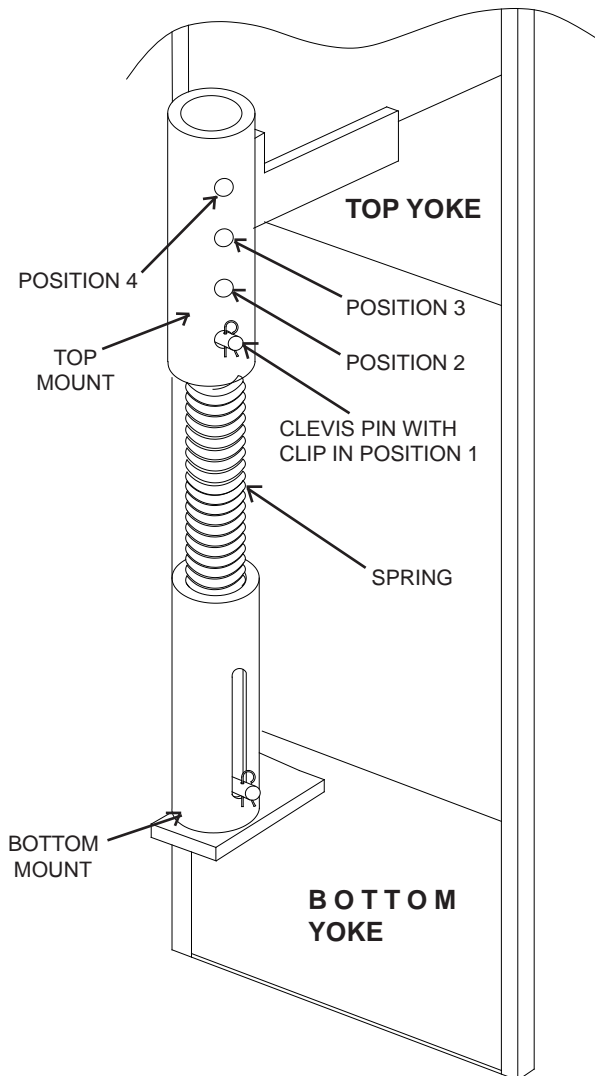

The Easy Climb System allows you to adjust the amount of spring tension put on the top feedwheel. The more spring tension you have the harder it will be for your top feedwheel to raise. More spring tension will keep the top feedwheel down on smaller brush material. The less spring tension you have the easier it will be for the top feedwheel to raise. Less spring tension allows the top feedwheel to raise, and climb over the larger diameter material. Additional spring tension requires more hydraulic yoke lift cylinder power to raise the top feedwheel. May require slight hydraulic relief valve adjustment.

There are four adjustment positions on the Easy Climb System. When adjusting spring tension have the top feedwheel in the lowered position. Use the Clevis Pin with Clip to adjust the tension. Make sure that the Clevis Pin is installed properly and that the Clip is secured tightly in place.

With the pin in position 1 the Easy Climb System will have approximately 6" (152 mm) of travel before you start spring tension. Use this position when chipping the maximum diameter material allowed by the chipper.

With the pin in position 2 the Easy Climb System will have approximately 4" (102 mm) of travel before you start spring tension. Use this position while chipping slightly smaller material than the maximum diameter material allowed by the chipper.

With the pin in position 3 the Easy Climb System will have approximately 2" (51 mm) of travel before you start spring tension. Use this position when chipping brush type material.

With the pin in position 4 the Easy Climb System will have approximately 0" of travel before you start spring tension. Use this position when chipping small brush type material.

ADJUST ACCORDINGLY AS SPRINGS STRETCH.

Bandit

ANVIL ADJUSTMENT

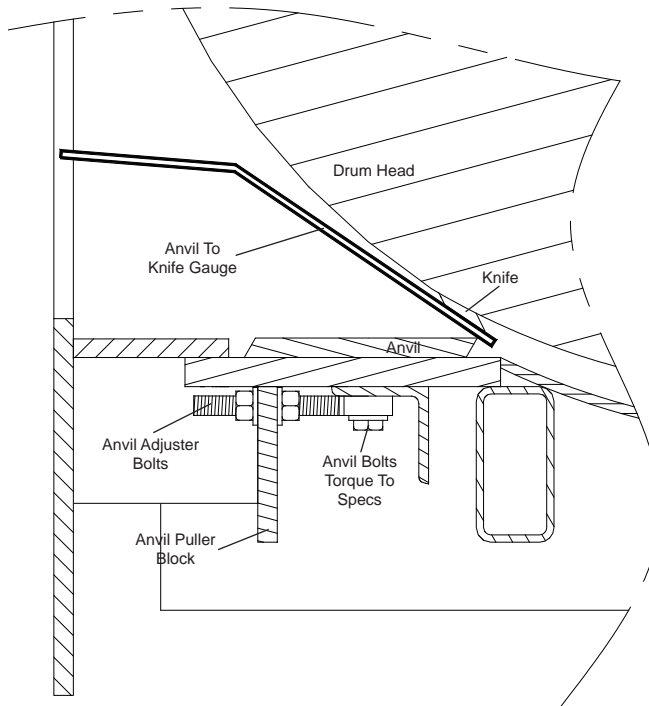

⚠ DANGER

Before attempting any type of maintenance disengage clutch, turn off engine, wait for the drum to come to a complete stop, install the drum lock pin, disconnect battery, and make sure the ignition key is in your possession.

Before working inside the infeed hopper or under the top feedwheel remove the easy climb springs from the top yoke, raise the yoke, install the yoke lock pin, safety chain the yoke in the raised position, and insert a wooden block to assist in holding the yoke in the raised position.

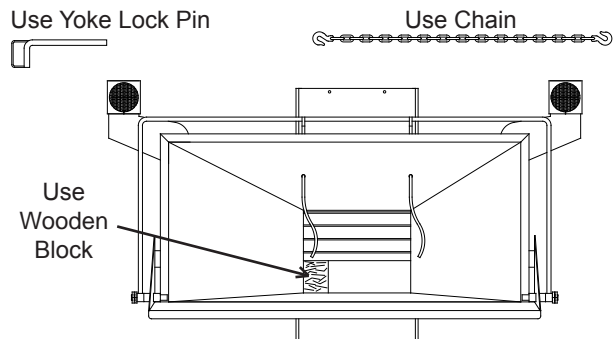

Check the Anvil to Knife Clearance

This clearance should be checked on a weekly basis or as knives are changed. To check the anvil clearance the above safety procedures must be taken. Once all safety procedures are completed the anvil to knife clearance can be checked. In order to check the clearance one person will need to climb into the infeed hopper. Use a feeler gauge or the anvil to knife gauge supplied by Bandit to check the clearance of the first knife to the anvil. Check the clearance at the left and right sides of the knife. Once that knife has been checked climb back out of the infeed hopper, remove the drum lock pin, and very carefully rotate the chipper drum so the other knives can be checked.

⚠ DANGER

Do Not under any circumstance attempt to rotate the chipper drum while someone is inside the infeed hopper. They may become seriously injured, Do Not Do This!

Once the drum has been rotated, reinstall the drum lock pin, and then check the clearance between the next knife. Once all knives have been checked adjust the anvil according to the closest knife. The anvil to knife clearance should be .120 inches (3.0 mm). Set the closet knife to this distance.

Anvil Adjustment Procedure

(Refer to above Figure)

To adjust the anvil first loosen two of the hex nuts on either the inside or outside of the anvil puller block. If the anvil needs to be adjusted closer to the drum, loosen the outside hex nuts. If the anvil needs to be adjusted away from the drum, loosen the inside hex nuts. Next loosen the anvil clamp bolts from underneath the machine. Once the components have been loosened, move the anvil to the correct clearance using the adjuster bolts and hex nuts. Once the knife is set to the correct clearance, .120 inches (3.0 mm), retighten all components. Make sure bolts are torqued to their specific bolt torques refer to bolt torques on page 41. Carefully rotate the chipper drum to make sure all the knives clear the anvil.

Bandit

CABLE/ROPE SHEAR

⚠ DANGER

Before attempting any type of maintenance disengage clutch, turn off engine, wait for the drum to come to a complete stop, install the disc/drum lock pin, disconnect battery, and make sure the ignition key is in your possession.

CHECK THE CABLE/ROPE SHEAR TO KNIFE CLEARANCE

1. This clearance should be checked on a weekly basis or as knives are changed. To check the cable/rope shear clearance, follow all pre-maintenance shut down procedures. Once all safety procedures are completed the cable/rope shear to knife clearance can be checked.
2. Remove the padlock on the hood pin, unplug the chipper hood engine disable plug, and pull the hood lock pin out to open the hood door.
3. Remove the drum lock pin.
4. Use a feeler gauge or the anvil to knife gauge supplied by Bandit to check the clearance of the first knife to the cable/rope shear. Check the clearance at the left and right sides of the knife.
5. Once that knife has been checked, very carefully rotate the chipper drum so the other knives can be checked.
6. Once all knives have been checked adjust the cable/rope shear according to the closest knife. The cable/rope shear to knife clearance should be .120 inches (3.0 mm).
7. To set the closet knife to this distance, see the CABLE/SHEAR ADJUSTMENT PROCEDURE.

NOTICE

- The cable/rope shear clearance needs to be checked on a weekly basis and every time the knives are changed or sharpened.
- Make sure the adjustment hex bolts on the mount bar are tight and loc-tited in place.
- Make sure the counter knife bolts are tight and loc-tited in place.

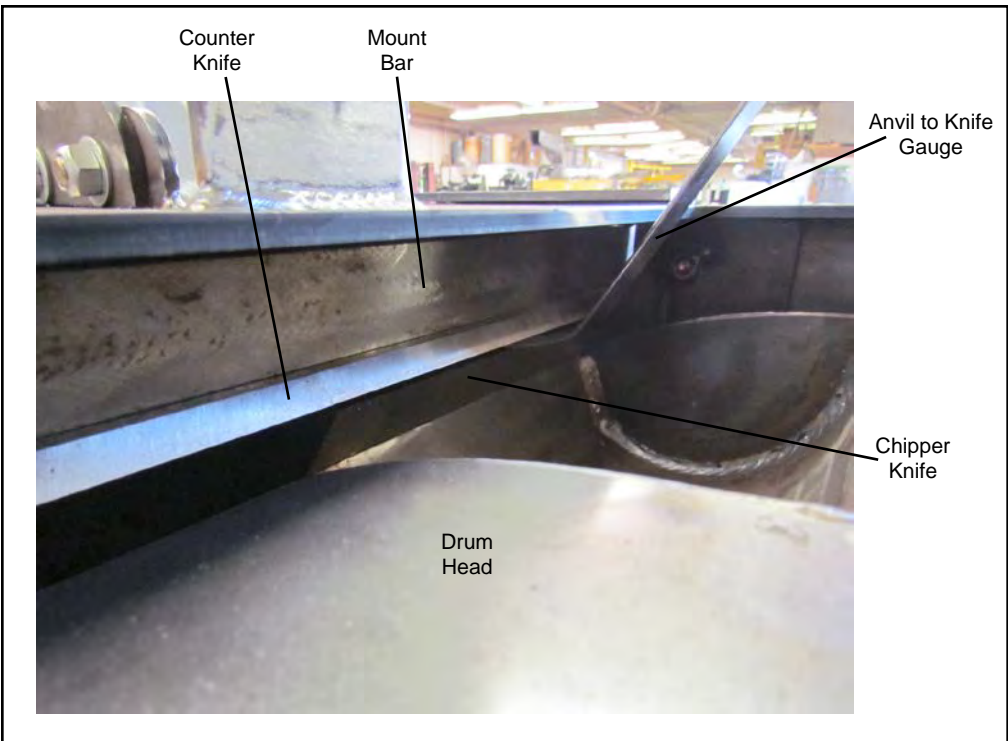

CABLE/ROPE SHEAR

⚠ DANGER

Before attempting any type of maintenance disengage clutch, turn off engine, wait for the drum to come to a complete stop, install the disc/drum lock pin, disconnect battery, and make sure the ignition key is in your possession.

CABLE/ROPE SHEAR COUNTER KNIFE REPLACEMENT

1. To replace the cable/rope shear counter knife, first remove the cable/rope shear adjustment cover on either side of the drum housing.
2. Remove the two adjustment hex bolts on each side cable/rope shear mount bar.
3. Move the cable/rope shear towards the feed system.
4. Pull the counter knife and mount out the side of the drum housing.
5. Remove the counter knife bolts.
6. Clean the loc-tite off the counter knife bolts and from the mounting holes.
7. Install the new counter knife to the mount bar.
8. Apply Loc-Tite 242 (blue) to the counter knife bolts and torque them to 15 ft-lbs (20 Nm).
9. Slide the cable/shear assembly back through the side of the drum housing and set into place.
9. Follow the CABLE/SHEAR ADJUSTMENT PROCEDURE to finish installing the cable/shear assembly.
10. Remove the drum lock pin and carefully rotate the chipper drum to make sure all the knives clear the cable/rope shear.

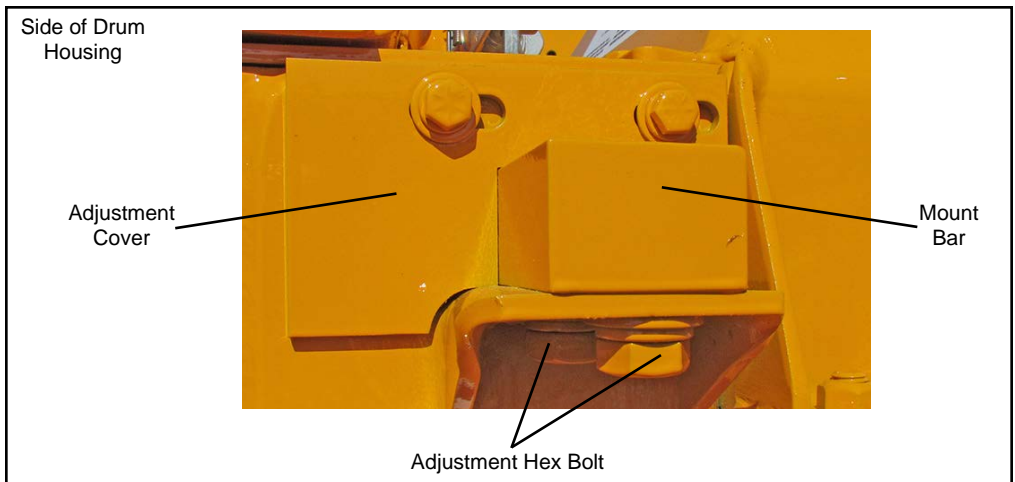

⚠ DANGER

Before attempting any type of maintenance disengage clutch, turn off engine, wait for the drum to come to a complete stop, install the disc/drum lock pin, disconnect battery, and make sure the ignition key is in your possession.

CABLE/ROPE SHEAR ADJUSTMENT PROCEDURE

1. To adjust the cable/rope shear, after the clearance has been checked first loosen the cable/rope shear adjustment cover on either side of the drum housing.
2. Remove the two adjustment hex bolts on each side cable/rope shear mount bar.
3. Clean the Loc-Tite off the adjustment hex bolts and from the mounting holes.
4. Move the cable/rope shear to the correct clearance.
5. Once the knife is set to the correct clearance, .120 inches (3.0 mm), retighten all components.
6. Apply Loc-Tite 242 (blue) to the adjustment hex bolts and torque them to 180 ft-lbs (244 Nm).
7. Tighten the cable/rope shear adjustment covers.
8. Remove the drum lock pin and carefully rotate the chipper drum to make sure all the knives clear the cable/rope shear.

PROPER PROCEDURE FOR INSTALLATION AND REMOVAL OF J.B. COUPLERS AND TAPERED FEEDWHEEL MOTORS

A. Proper Equipment Needed:

1. Feedwheel motor with tapered shaft.
2. 5/16" x 9/32" x 1 1/4" long key (900-3937-23) for "DT" motor.
5/16" x 9/32" x 15/16" long key (900-3934-06) for "RE" motor.
3/16" x 3/16" x 3/4" long key (900-3937-03) for "RS" motor.
3. Correct feedwheel shaft, coupler and taper pin ass'y
4. Loc-Tite 271 (red).
5. Loc-Tite 241 (blue).
6. Emery cloth and/or a file.
7. A degreaser agent.
8. Self locking nut.
9. Hammer.
10. Torque wrench and
1 5/8" socket for "DT" motor.
1 3/8" socket for "RE" motor.
1 3/16" socket for "RS" motor.
11. 1 1/16" hand wrench for "RE" motor.
7/8" hand wrench for "RS" motor.

B. Installation Procedure

1. Remove any sharp edges on the coupler bores or the motor shaft.
Example: Emery cloth or file for burrs on keyways or shafts.
2. Clean the coupler bores and motor shaft with a degreasing solvent.
3. Install the correct key in the feedwheel motor shaft.
4. Slide the coupler onto the motor shaft, making sure that the two mate tightly.
Example: The coupler does not rock or slop on the shaft.
5. Install the self locking nut with Loc-Tite 271 on the threads.
6. Tighten to the correct torque, 340 ft.-lbs. (461 Nm) for "DT" motor, 250-300 ft.-lbs. (339-407 Nm) for "RE" motor, & 150-170 ft.-lbs. (203-230 Nm) for "RS" motor.
7. Slightly tap with a hammer on the coupler face to insure proper seating.
8. Retorque self locking nut.
9. Deburr and degrease the feedwheel shaft.
10. Install the motor and coupler assembly onto the feedwheel shaft.
11. Install the correct tapered pin through the coupler and feedwheel shaft.
12. If coupler pin is threaded and is equipped with a nut, make sure the nut is flush with top of pin.
13. Hammer the pin into the coupler to secure the coupler and feedwheel shaft. If the pin is threaded and has a nut do not hammer the pin directly, use a piece of wood as a buffer.
14. If the tapered pin is equipped with a nut, put Loc-Tite 241 on the threads and then tighten nut flush with top of pin.

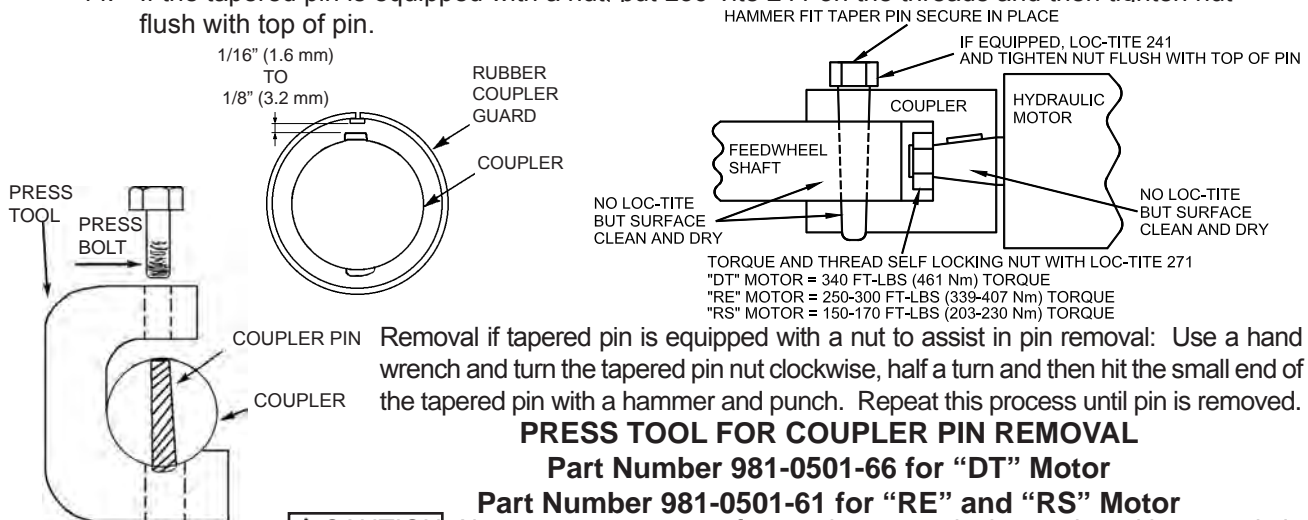

Always wear proper safety equipment and take caution with tapered pin when attempting to remove. The use of this tool will assist in the removal of the tapered pin in the feedwheel coupler. Lubricate end of bolt and threads with grease. Position the press tool so that it cradles the coupler, with the large end of the tapered pin at the side opposite the press bolt. You may want to remove yoke springs to get easier access to coupler. Set the tool as described and hand tighten press bolt to snug tool against coupler. Make sure press bolt is set on small end of tapered pin, and that pin will go through hole in tool without interference. Use of a 1/2" impact wrench is recommended. Run impact on bolt to start pin removal, then usually a good hit with hammer on the end of bolt will knock out the pin. You may have to run impact on bolt and hit with hammer a few times to remove pin. Do not spend excessive time trying to remove the pin and coupler. If problems occur during pin and coupler removal, contact your nearest dealer or Bandit Industries.

**PROPER PROCEDURE FOR INSTALLATION AND REMOVAL
OF TAPERLOCK KEYLESS FEEDWHEEL COUPLERS AND
FEEDWHEEL MOTORS**

A. Proper Equipment Needed:

- | | |
|--|----------------------|
| 1. Feedwheel motor with straight shaft. | 4. Torque wrench |
| 2. Correct feedwheel shaft and coupler ass'y | 5. 17mm crow foot |
| 3. Emery cloth and/or a file | 6. A degreaser agent |

NOTICE

Never tighten locking screws before shaft installation, as the coupler sleeve bore can be permanently deformed even at relatively low tightening torques.

B. Installation Procedure

1. Remove any sharp edges on the coupler bore, the motor shaft, or the feedwheel shaft.
Example: Emery cloth or file for burrs on shafts.
2. Rough up the feedwheel shaft and feedwheel motor shaft horizontally along the axis of the shaft.
3. Clean the coupler bore, motor shaft, and feedwheel shaft with a degreasing solvent.
4. Slide the coupler onto the feedwheel shaft until it stops.
5. Install the motor with the torque arm installed into the feedwheel shaft.
6. Tighten the coupler locking screws in several stages by using 1/4 turns or 90° in a clockwise or counter-clockwise direction (not diametrically opposed, like wheel lug nuts) until you reach a torque of 55 ft.-lbs. (74 Nm).
7. Make 2 more passes torquing the locking screws to 55 ft.-lbs. (74 Nm) after the torque has been reached.
8. Make 1 more pass torquing the locking screws to 52 ft.-lbs. (71 Nm). No screws should turn at this point or repeat step 7.

WARNING

DO NOT completely remove locking screws before outer collars are disengaged from inner ring. A sudden release of the outer collars involves high separating forces and could result in permanent injury or death. Be certain that outer collars are disengaged from inner ring before completely removing locking screws.

C. Removal Procedure

1. Make sure there are no torque or thrust loads on the coupler, feedwheel shaft, or feedwheel motor.
2. Loosen the locking screws in several stages by using 1/2 turns, following a clockwise or counter-clockwise direction, until the coupling can be moved on the shaft.
3. Remove the feedwheel motor and then the coupler.

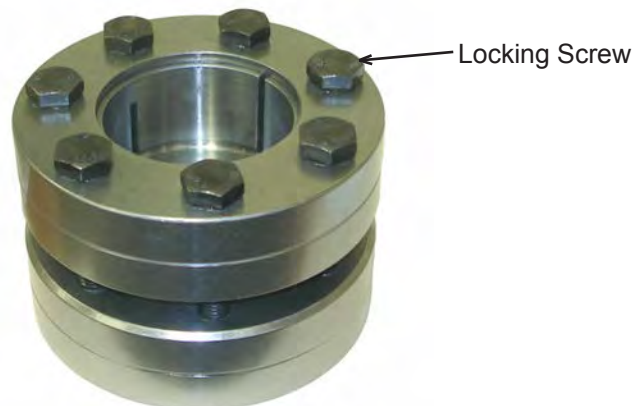

Taperlock Keyless Coupler

SERVICING / CHANGING FEEDWHEEL BEARING (WITH THE GRIP TIGHT BEARING BEHIND FEEDWHEEL MOTOR)

Your Bandit Chipper maybe equipped with a tapered lock style (Grip Tight) feedwheel bearing on the hydraulic motor side of the feedwheel and a conventional (set screw) style on the opposite side. With the Grip Tight bearing this gives a very positive locking system to the feedwheel shaft. The set screws on both bearings should still be checked as part of normal maintenance.

A few simple rules and installation instructions must be followed if the bearings ever need to be replaced or removed during service.

The machine is set up with one set screw bearing and one Grip Tight bearing because the one Grip Tight bearing is all that is needed to securely hold the feedwheel shaft (along with the set screws on the opposite bearing). This also makes for very easy assembly. **When installing the bearing it is very important to install and lock the Grip Tight bearing first with the set screw bearing done after.** This is to keep the bearings from being put into a side load which will lead to premature failure.

Installation procedure:

- 1) Clean the feedwheel shaft of all debris, use a degreaser.
- 2) Install both feedwheel bearings on the feedwheel shaft with the Grip Tight bearing on the hydraulic motor side and the set screw bearing on the opposite side. **Do not lock the bearings on the shaft at this time, allow the feedwheel to shift freely for installation.**
- 3) Position the feedwheel in the yoke mount and install all (8) feedwheel bearing bolts with a thread locking compound applied. These are completely tightened and torqued at this time (refer to bolt torque chart).
- 4) The feedwheel then needs to be centered in the yoke and then it must be off set 3/16" (4.8 mm) towards the set screw bearing side (away from the hydraulic motor). The weight of the feedwheel needs to be taken off the bearings also.
- 5) First the Grip Tight bearing lock nut must be tightened by hand as tight as possible (in a clock wise direction). This is the zero reference point. Scribe a line on the lock nut above the adapter slot.
- 6) Using a spanner wrench or drift pin and hammer, lock the bearing to the shaft by tightening the lock nut in a clock wise direction. Tighten 3/4 to 1 full turn (you may need to block the feedwheel from turning at this time). Now you can tighten the set screws on the Grip Tight bearing. Note: the set screw is only to be tightened to 25 in.-lbs. (2 ft.-lbs.) (2.7 Nm).
- 7) Apply a thread locking compound on the set screws of the set screw bearing and torque to 20 ft.-lbs (27 Nm).

Grip Tight Bearing



Set Screw Bearing



**SERVICING / CHANGING CHIPPER BEARING
(FOR LINK BELT PB22647FHK4/2 SERIES)**

NOTE: Proper installation is critical to bearing life. Improper installation could cause premature or immediate failure. Particular care must be taken not to create a preload on the bearings while tightening the locknut. Use of a good quality torque wrench is also important to your safety as well as proper bearing installation.

1. Clean the shaft so that it is free from burrs and rust. Do not coat the chipper shaft or the bore of the bearing adapter with a preservative or lubricant.
2. Remove the bearing adapter and apply a light weight oil to the outer surface and threads. Reassemble the adapter in the bearing with about 1/4" (6.4 mm) if clearance between the bearing face and lockwasher. Repeat the process to the other bearing.

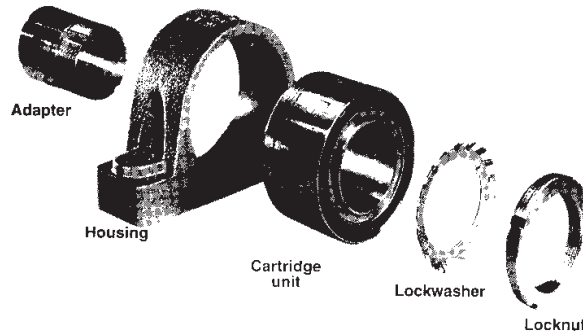

3. Center the chipper drum inside the base and bolt the bearing down on the road side of the machine and tighten the four bearing bolts to 220 ft.-lbs. (298 Nm) of torque.
4. Keeping the drum centered, take a large flat blade screwdriver to wedge between the bearing's face and lockwasher on the road side of the machine. Use the screwdriver to draw the adapter through the bearing until there is a snug fit between the adapter and chipper drum shaft. Finger tighten the locknut, then use a hook type spanner wrench to bring the locknut to a snug fit.

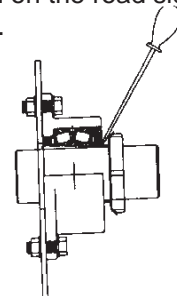

5. Mark the locknut and chipper drum shaft with a grease pencil or a dark marker. Use a soft steel drift pin and a hammer to drive against the face in a circular movement of the locknut as shown in the following picture. Retighten the locknut with a spanner wrench and repeat procedure until 7/8 of a turn is achieved.

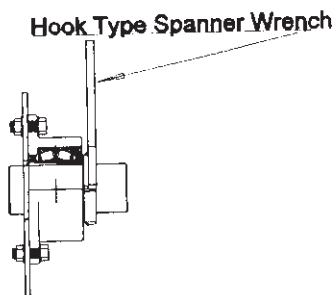
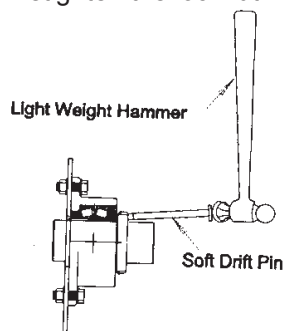

6. Find the tang of the lockwasher that is in line with a slot in the locknut and bend it over into the slot. If needed tighten the locknut slightly until one of the slots line up.
7. Offset the bearing on the curb side of the machine about 1/8" (3.2 mm) to 3/16" (4.8 mm) away from the drum housing, so that when the bearing is tightened up on the shaft, the bolt holes will line up. The bearing housing should not be wedged up against the base, if it is the bearing will have a preload.
8. Repeat steps 4 through 6 to tighten the curb side bearing on the shaft.
9. Loosen all the bearing bolts to release the preload on the bearings if there is any. Bolt both bearings down and torque the bolts to 220 ft.-lbs. (298 Nm)
10. If the drum head does not spin freely, there is a preload on the bearings and steps 7 through 9 need to be repeated.

MAINTENANCE

PROCEDURE FOR UNPLUGGING YOUR CHIPPER

If your chipper is plugging, it is usually caused by allowing the engine to drop below required R.P.M.'s. This can be resolved by simply shutting the feedwheel(s) off when the engine begins to lug down. Operating the engine at speeds lower than full R.P.M.'s causes your chipper to plug. **Always run the chipper at full engine speed.** If your chipper is equipped with the optional autofeed feature, make sure it is set correctly. The setting for the low R.P.M. stop must be high enough not to allow the chipper discharge to plug. Dull chipper knives also contribute to chipper plugging. Dull knives can create slivers and chunks, causing the engine to lug excessively. Both of the aforementioned conditions cause a plugging situation.

STEPS TO FOLLOW WHEN UNPLUGGING YOUR CHIPPER

1. Before attempting any type of maintenance disengage clutch, turn off engine, wait for the disc/drum to come to a complete stop, install the disc/drum lock pin, disconnect battery, and make sure the ignition key is in your possession.
2. Make sure the chipper disc/drum is **NOT** turning and then open the hinged portion of the chipper hood.
3. Using gloved hands and some type of raking tool, dig the chips out of the chipper housing.
4. If the discharge chute is plugged, use a raking tool to pull the majority of chips out of the open outlet end of the chute. Then, two people must remove the chute. Do not attempt this with one person, because the chute can fall causing injury. If used properly, a hoist can be used to assist in the removal of the chute.
5. Never allow one person to turn the chipper disc/drum when someone else is working inside the chipper housing. More than likely, the chipper disc/drum will turn hard then loosen causing it to turn faster. If another person is anywhere near the chipper disc/drum, they may be injured.
6. Never turn the chipper disc/drum by hand. Always use a pry bar. This will prevent the person turning the disc/drum from being injured should the disc/drum break loose.
7. Reinstall the discharge chute, mount securely and point it in a safe direction away from anything.
8. Never leave the chipper hood open and try to start the engine in order to engage the chipper disc/drum to blow chips out of the housing, this is very hard on the P.T.O. of the chipper and may burn clutch plates. Also, the flying debris is very dangerous. An exposed chipper disc/drum turning very fast creates an unsafe condition. In other words, **DO NOT** start the chipper with the hood open because it is just too dangerous.
9. Once the disc/drum turns freely, close the chipper hood, insert the hood pin, install the padlock in the hood pin, reinstall the chipper hood engine disable plug, make sure the spring lock for hood pin springs back to the correct operating position on disc chippers, start engine, properly engage clutch and throttle to full speed. Insert a small branch into the feedwheel(s). If the chips discharge properly, the chipper is clear and normal operation may resume.

PAINT CARE

To help keep up the appearance of your Bandit Equipment and reduce the possibility of surface rust follow these steps:

- 1) The machine should be washed on a regular basis with a non-abrasive mild detergent and then rinsed thoroughly. Do not pressure wash sensitive areas like: decals, gauges, electronic devices, autofeed control, etc.
- 2) If a stone chip, paint scratch, or paint crack occurs - it should be repaired immediately. Simply sand the edges of the damaged paint area, mask off the surrounding area and apply primer and paint to the dry, clean, and warm surface. This will help keep the damaged area from spreading or getting worse.
- 3) If you are unable to sand and mask the area, there are containers of primer and paint available. A small brush can be used to touch up the area.
- 4) Also, primer and most colors of paint are available in aerosol spray cans to simply spray over the effected area after it is cleaned, dry, and warmed. This method is not as reliable as the process in step #2.

It is also reported that some equipment owners polish their machine at least yearly, and keep good mud flaps on their towing trucks.

 **DANGER**

**LOCKOUT ALL ENERGY SOURCES
BEFORE SERVICING OR REMOVING
GUARDS OR HOODS!**









1. Shut off engine/motor. Key in pocket.
2. Disengage pto/clutch.
3. Wait for cutter disc/drum to come to a **COMPLETE STOP** (takes at least several minutes).
4. Install disc/drum lock pin.
5. Loader arm (if equipped) securely on ground and hydraulic pressure released.
6. Unplug engine disable plug-in.
7. Remove padlock from hood pin.
8. Retract hood pin.

**DO NOT RESTART UNTIL ALL GUARDS
AND HOODS ARE SECURELY AND
PROPERLY REINSTALLED.**

TIRE WEAR DIAGNOSTIC CHART

Wear Pattern		Cause	Action
	Center Wear	Over Inflation	Adjust pressure to particular load per tire catalog
	Edge Wear	Under Inflation	Adjust pressure to particular load per tire catalog
	Side Wear	Not Hauling Trailer Level Bent Axles Wide Tires Wheel Bearings	Must be hauled parallel to ground Replace as needed Characteristic of wide flotation tires Adjust or replace
	Cupping	Out-Of-Balance Wheel Bearings	Check bearing adjustment and balance tires Adjust or replace
	Flat Spots	Wheel Lock Up & Tire Skidding	Avoid sudden stops when possible and adjust brakes.

The wear pattern and tread life of tires involves many variables that the user has control of, but DOES NOT fall under faulty manufacture or design.

The following is a list of some causes supplied by tire suppliers and axle manufacturers:

- Misalignment - from rough roads, pot holes, excessive speeds and hitting curbs.
- Tire Width - the wider the tire for flotation, the more uneven the tire wear.
- Tire Air Pressure - to much or too little, for the load.
- Vehicle Hitch Height - if trailer is not level with ground, axle camber is misaligned.
- Maintenance - wheel bearing lubrication and adjustment. Follow axle MFG. instructions.
- Brakes - uneven or misadjusted brakes cause irregular brake activation.

RECOMMENDED BRAKE ADJUSTMENT PROCEDURE PER AXLE MANUFACTURER.

The proper clearance between the shoe and drum surfaces will be set up initially from our factory to assure proper operation during the normal break in period. No further adjustment will be necessary until the vehicle completes the recommended break in period of 200 miles (322 km).

Since all brakes of this type must be burnished or "run in" before their full effectiveness can be achieved, the MFG. maintenance manuals call for readjustment after the first 200 miles (322 km) of operation. This usually allows ample time for the burnishing to take place. Readjustments are not necessary for brakes fitted with self-adjustment features although periodic inspection is suggested.

The following shows the correct adjustment for the MFG. brakes of 12 1/4" diameter.

NOTICE: Clearances that are too small will result in excessive drag and overheating while too much clearance can render the brake nonfunctional.

AXLE SIZE	SIZE	TYPE	DIAMETRAL CLEARANCE	CLICKS TO BACK OFF
7000 LBS.	12 1/4" X 2.5"	Elec. or Hyd.	.040" (1 mm)	7 TO 13
8000 LBS.	12 1/4" X 3.38"	Elec. or Hyd.	.040" (1 mm)	AUTOMATIC ADJUSTING

For additional brake adjustment procedures consult the axle manufacturer manual.

HYDRAULIC SECTION

⚠ WARNING

DO NOT GO NEAR HYDRAULIC LEAKS!

High pressure oil easily punctures skin causing serious injury, gangrene, or death. If injured, seek emergency medical help. Immediate surgery is required to remove oil. DO NOT use fingers or skin to check for leaks. Lower load or relieve hydraulic pressure before loosening fittings.

DO NOT operate this machine unless all hydraulic control devices operate properly. They must function, shift and position smoothly and accurately at all times. Faulty controls can cause personal injury!

Hydraulic Fluid Requirements

This machine is equipped with “Petro-Canada Hydrex XV” hydraulic fluid. It is recommended to replace with the same. “Petro-Canada Hydrex XV” is an all season hydraulic fluid. This is a premium performance, long life anti-wear, hydraulic fluid, designed for all season use in heavy duty hydraulic systems. “Petro-Canada Hydrex XV” allows year round use under wide extremes of temperature. It allows the hydraulic system to start at temperatures as low as -40°C/-40°F, under no load conditions and it improves lubrication of hydraulic components at high operating temperatures. It will also help protect against hydraulic failures during the wide temperature swings of spring and fall. To find the closest “Petro-Canada Hydrex XV” dealer call 1-888-284-4572.

Multi Viscosity motor oils not recommended to mix with “Petro-Canada Hydrex XV” hydraulic oil. AW oils may mix with “Petro-Canada Hydrex XV” hydraulic oil. The following are specifications and authorizations of compatible oils. Only a high quality anti-wear (AW) hydraulic oil containing foam, corrosion, rust and oxidations inhibitors should be used. This viscosity grade depends on the oil temperature in service, based on the climate and operating conditions.

	Hydrex XV	ISO 22, AW	ISO 32, AW	ISO 46, AW	ISO 68, AW	ISO 100, AW
Viscosity Index	>235	>95	>95	>95	>95	>95
Flash Point	>240°C /464°F	>200°C /395°F	>210°C /410°F	>220°C /430°F	>220°C /430°F	>240°C /464°F
Oxidations Stability (ASTM D0943)	>9,000 Hours	>3,000 Hours	>3,000 Hours	>3,000 Hours	>3,000 Hours	>3,000 Hours
Cold Start-up, No Load, Max	-40°C/-40°F	-34°C/-29°F	-26°C/-14°F	-19°C/-3°F	-9°C/16°F	-4°C/24°F

HYDRAULIC SECTION

Alternate hydraulic oils are available, but they do not equal the performance or longevity of the “Hydrex XV” oil. Consult the following information supplied by the oil distributor.

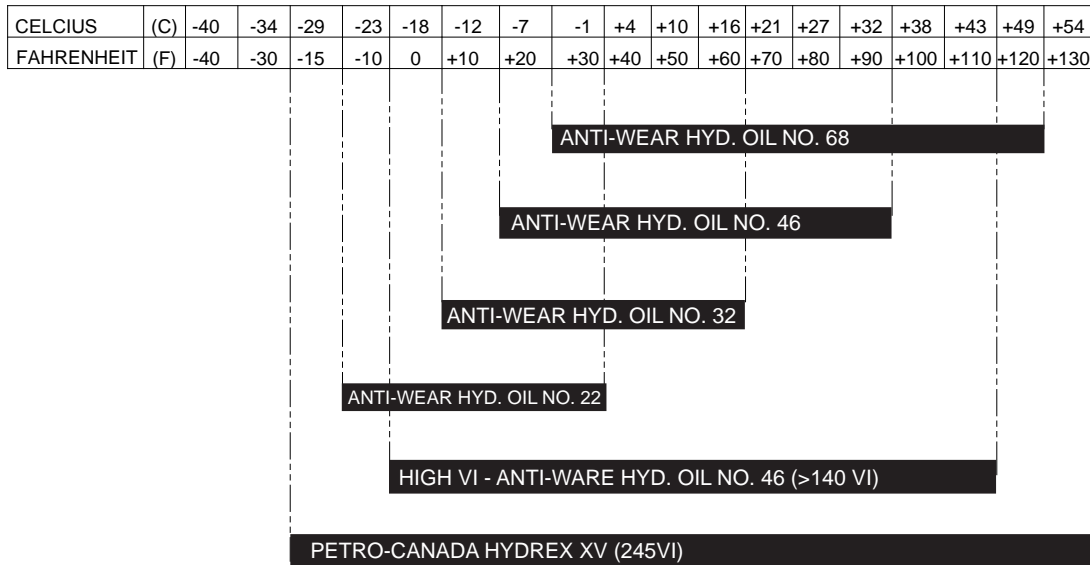

Note: The above chart is a suggested guide for viscosity of hydraulic fluids at start up ambient temperature. The load, demand, and cleanliness of the equipment will affect actual oil temperatures which can increase dramatically above ambient air temperatures during operation. The actual viscosity needed is based on oil temperature during operation and not air temperature. Compare your fluid specifications with the specifications below to verify compliance.

When choosing a hydraulic fluid - these maximum and minimum specifications must be met:

Minimum Viscosity during operation = 12 cSt
 Maximum No-Load Viscosity at start-up = 2000 cSt

Hydraulic fluids vary in their resistance to oxidation at elevated temperatures, their ability to protect against metal-to-metal contact under increasing temperature, and their ability to separate water from the fluid. Viscosity is temperature dependant. Fluids with high viscosity-index (VI) will thin out slower at higher temperature and thicken slower at colder temperatures allowing a wider operating range. Choose a fluid that has test results in these areas for best results.

Based on the varying temperatures of the area where Bandit equipment is used, and the high demand and loads placed on this equipment, Bandit has filled each hydraulic system with Petro-Canada’s Hydrex XV All Season Hydraulic Fluid for maximum protection and performance.

Contact Petro Canada at (888) 284-4572 to find a dealer near you.

Note: Some equipment and components such as fluid engagement clutch’s (PTO’s) have their own lubrication requirements. Consult their manufactures manual for that information.

MODELS 1290XP/1590

TYPICAL HYDRAULIC RELIEF PRESSURE SETTINGS TYPICAL HYDRAULIC FLOWS AND RPM SETTINGS (Approximate, For Reference Only, Engine At Full RPM)

Equipment Model	1290XP (Pre S/N 7070)	1290XP (Starting S/N 7071)
Pump GPM (LPM)	5.2 (19.7)	10.2 (38.6)
Top Feedwheel GPM (LPM)	5.2 (19.7)	5.1 (19.3)
Bottom Feedwheel GPM (LPM)	5.2 (19.7)	5.1 (19.3)
Feedwheel RPM	35-37	32-35
If Equipped Main Relief PSI (bar)	2500 (172)	2500 (172)
Feed Relief PSI (bar)	2500 (172)	2500 (172)
Yoke Up Relief PSI (bar)	1500 (103)	1500 (103)
Yoke Down Relief PSI (bar)	1500 (103)	1500 (103)
Winch Relief PSI (bar)	2200 (152)	2200 (152)
Disch. Rotate PSI (bar)	500-800 (34-55)	500-800 (34-55)
Disch. Flipper PSI (bar)	500-800 (34-55)	500-800 (34-55)
Front Stab. PSI (bar)	2200 (152)	2200 (152)

Equipment Model	1590
Pump GPM (LPM)	10.2 (38.6)
Top Feedwheel GPM (LPM)	5.1 (19.3)
Bottom Feedwheel GPM (LPM)	5.1 (19.3)
Feedwheel RPM	35-37
If Equipped Main Relief PSI (bar)	2500 (172)
Feed Relief PSI (bar)	2500 (172)
Yoke Up Relief PSI (bar)	1500 (103)
Yoke Down Relief PSI (bar)	1500 (103)
Winch Relief PSI (bar)	2200 (152)
Disch. Rotate PSI (bar)	500-800 (34-55)
Disch. Flipper PSI (bar)	500-800 (34-55)
Front Stab. PSI (bar)	2200 (152)

NOTICE

DO NOT UNDER ANY CIRCUMSTANCES OVER-SET THESE RELIEF PRESSURES, BECAUSE IT WILL CAUSE DAMAGE TO COMPONENT PARTS AS WELL AS HYDRAULIC PARTS.

NOTE: These Typical Hydraulic Flows And Relief Pressure Settings Are With The Engine At Full RPM. All Settings Are Subject To Change!

HYDRAULIC SECTION

THE BANDIT HYDRAULIC SYSTEM

The Bandit is equipped with a very efficient, simple hydraulic system. Each component is capable of withstanding a specified PSI (bar) and still operate for a very long time.

If the simple rules mentioned below are followed, the hydraulic components will last for years:

- After you have operated a new machine for approximately an hour shut down the machine and recheck all hydraulic fittings for tightness and leaks.
- Avoid hydraulic pump cavitation. Low oil levels or cold start-ups will cause the hydraulic pump to cavitate. Cavitation will ruin the pump and possibly the entire hydraulic system. Cavitation only has to happen once. This will start the pump on its way to ruin. Allow hydraulic system to turn slowly for several minutes in cold weather in order for hydraulic system to warm up. Cavitation is not covered under warranty.
- Do not increase the feedwheel relief valve settings beyond specified PSI (bar). This will cause damage to hydraulic components. Do not set any other hydraulic component past it's specified pressure or this will cause damage to the hydraulic components.
- Keep hydraulic oil clean. Dirty oil will cause excessive wear and loss of hydraulic power.
- Replace the hydraulic oil filter(s) after first 10 hours and with each 400 hours of operation or 3 months.
- Replace hydraulic oil & suction screen(s) at least once yearly. This is also a very good time to flush and clean the tank. Replace hydraulic oil immediately if it is contaminated or looks "milky". See pages 54 - 55 for hydraulic oil requirements.

- If the Bandit's hydraulic system is kept clean and the hydraulic pressures are not increased beyond the specified PSI (bar), the maximum use and life should be received from the Bandit chipper hydraulic system.

- If a problem is encountered, it will more than likely be located in the relief valve or something as simple as belts slipping, check these first.

- Only use the optional adjustable flow control when chipping large diameter trees. Do not leave the speed adjustment partially open for long periods of time. This will cause excessive heat to the hydraulic system! Excessive heat will cause low feedwheel power and premature failure of all hydraulic components. Always operate system at full oil flow unless chipping large diameter trees.

- Do not close the optional hydraulic shut-off valve for more than 3 to 4 seconds. Hydraulic shut-off valve handle must be completely turned on (in line with hose) at all times unless checking hydraulic pressure. Pressure gauge should be safely stored and installed only when checking pressure. Follow above instructions or this will cause unwarranted damage to the hydraulic components.

- Never close the ball valves on the hydraulic tank suction ports (if equipped) while the machine is running, this will ruin the hydraulic pump and components.

- Some component manufacturers require different specific hydraulic lubrication, such as gear boxes, undercarriage drives, etc. Refer to their manuals and maintenance section of this manual.

HYDRAULIC COMPONENTS

Feedwheel hydraulic motor(s):

These hydraulic motor(s) are attached to the feedwheel(s) by a tapered feedwheel motor connection or by a clamp style connection.

Hydraulic pump:

The hydraulic pump could be bolted directly to the engine, or may be driven by a sheave/belt combination off of the chipper shaft.

Suction strainer(s):

This strainer(s) stops contaminants from reaching the hydraulic pump. The suction strainer(s) should be replaced at least once yearly or every 2000 hours.

Hydraulic tank:

This tank must be kept clean and filled minimum 7/8 full. Clean tank yearly.

Filter:

This spin-on cartridge filter must be replaced per maintenance schedule.

Filter mount:

The filter is tightened on the Filter Mount.

Feedwheel valve:

This valve is actuated by the control bar. The valve actuates the feedwheel for forward, off or reverse. It may also contain an adjustable relief valve.

Bandit

HYDRAULIC SECTION

THE BANDIT CHIPPER IS EQUIPPED WITH ONE OF THREE POSSIBLE MAIN RELIEF HYDRAULIC PRESSURE ADJUSTMENT PROCEDURES

PROCEDURE 1 FOR MODELS 1290XP/1590 WITH NO OPTIONS

The relief valve is typically located internally in the control valve. Do not adjust this relief valve above 2500 PSI (172 bar). The relief valve system is a simple spring tension design but small pieces of debris can stick the valve partially open which weakens the feedwheel power. The relief as well as hydraulic oil, and screen must be kept clean.

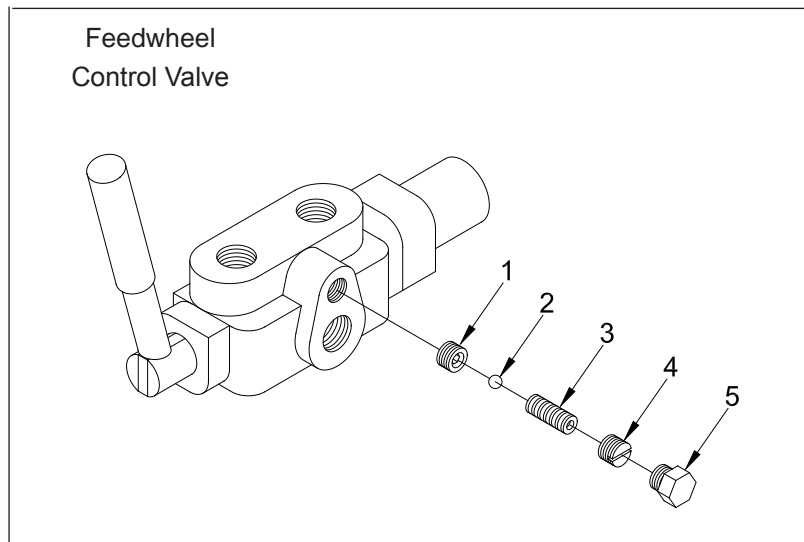

1. **VALVE SEAT:**
The springs pushes the relief valve ball against it, until pressure builds.
2. **POPPIT VALVE:**
This ball opens and closes to relieve excess pressure on hydraulic system.
3. **RELIEF SPRING:**
This spring tensions the amount of pressure required to open the relief valve ball. This spring weakens and must be checked and/or readjusted every month for best performance.
4. **SLOTTED SET SCREW:**
Turn clockwise to increase pressure, but do not surpass maximum of 2500 PSI (172 bar).
5. **HEX HEAD PLUG:**
Remove to access the relief valve.

YOUR BANDIT CHIPPER IS EQUIPPED WITH ONE OF TWO HYDRAULIC PRESSURE ADJUSTMENT PROCEDURE OPTIONS.

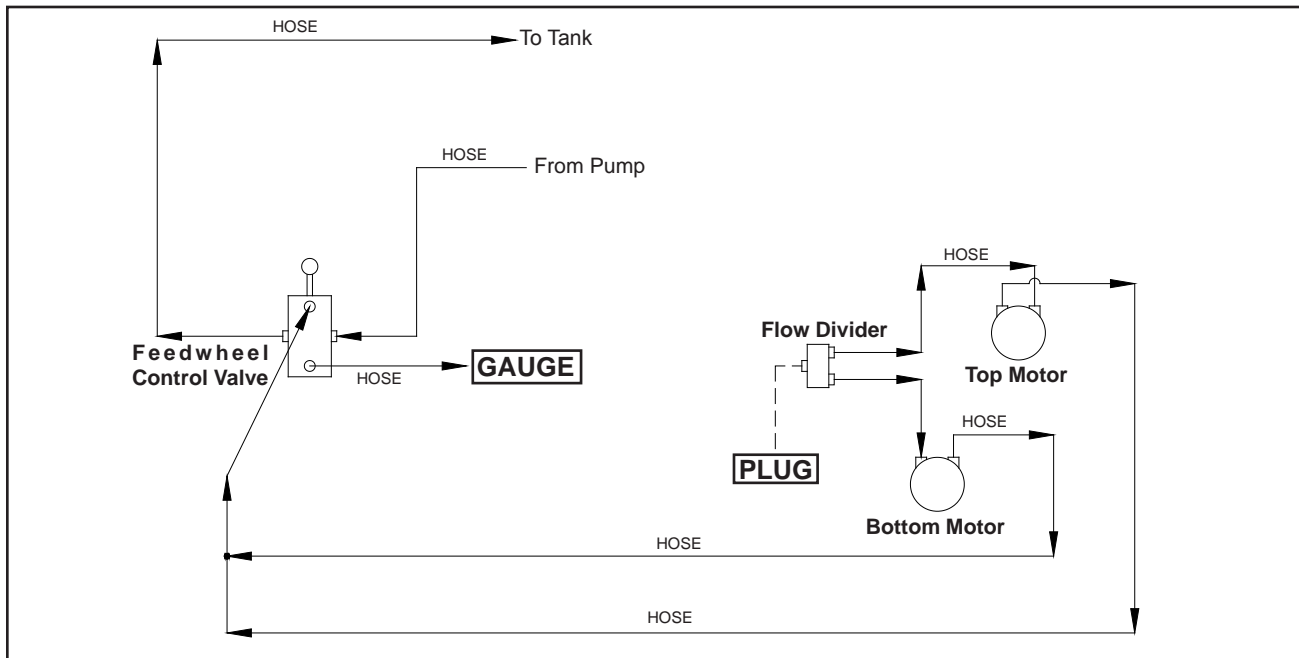

⚠ WARNING

PROCEDURE 1 FOR MODELS 1290XP/1590 WITH NO OPTIONS cont.
CHECKING AND ADJUSTING RELIEF VALVE PRESSURE

Before attempting any hydraulic pressure settings, make sure engine is shut off, engine key removed and in your possession, hydraulic oil is clean, hydraulic tank is 7/8 full, and the machine has been pre-run to warm the hydraulic oil. To correctly check relief valve pressure, gauge MUST be installed correctly.

1. First put control handle in off position.
2. Disconnect flow divider from control valve, and plug port on flow divider.
3. Leave all other hydraulic hoses connected.
4. Install pressure gauge in port on control valve from which flow divider was disconnected.
5. Start engine, and engage control handle to normal operating position.
6. Adjust engine to full throttle to activate reading on pressure gauge.
7. Pressure gauge should read maximum 2500 PSI (172 bar).
ONLY RUN ENGINE FOR 4-5 SECONDS TO SET PRESSURE OR YOU MAY DAMAGE HYDRAULICS.
8. Readjust relief pressure setting if needed, if not needed, shut off engine remove plug and gauge. Reassemble flow divider to control valve.
9. Check for hydraulic leaks.
10. Relief valve pressure should be checked and/or readjusted every month for best performance.

MAINTAIN FEEDWHEEL HYDRAULIC PRESSURE AT 2500 PSI (172 bar).

YOUR BANDIT CHIPPER IS EQUIPPED WITH ONE OF TWO HYDRAULIC PRESSURE ADJUSTMENT PROCEDURE OPTIONS.

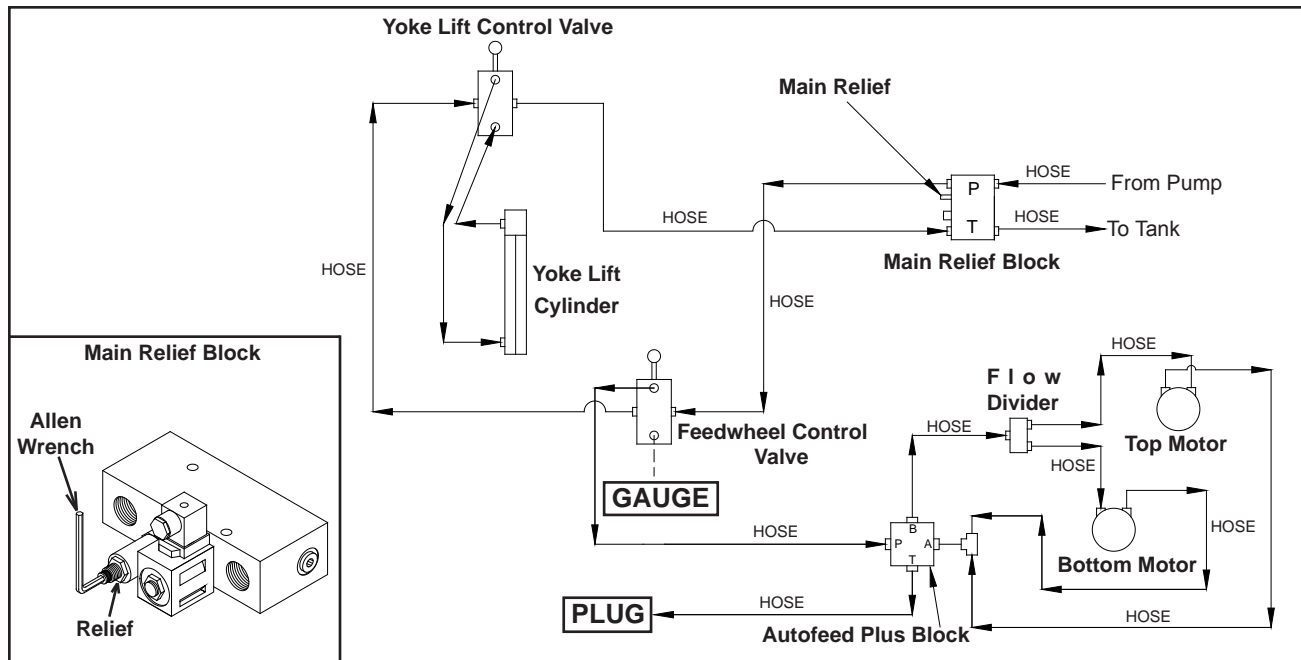

⚠ WARNING

PROCEDURE 2 FOR MODELS 1290XP/1590 WITH OPTIONS
(SHOWN WITH AUTOFEED PLUS AND LIFT CYLINDER OPTIONS COMBINED)

Before attempting any hydraulic pressure settings, make sure engine is shut off, engine key removed and in your possession, hydraulic oil is clean, hydraulic tank is 7/8 full, and the machine has been pre-run to warm the hydraulic oil. To correctly check relief valve pressure, gauge MUST be installed correctly.

1. First put control handle in off position.
2. Disconnect hydraulic hose going from autofeed plus block (or from flow divider if machine not equipped with autofeed plus) to feedwheel control valve at the feedwheel control valve end.
3. Install pressure gauge in port on feedwheel control valve where you disconnected the hose and plug the end of the hose.
4. Start engine and adjust engine to full throttle to activate reading on pressure gauge.
5. Pressure gauge should read maximum 2500 PSI (172 bar).
ONLY RUN ENGINE FOR 4-5 SECONDS TO SET PRESSURE OR YOU MAY DAMAGE HYDRAULICS.
6. Locate relief next to autofeed solenoid, loosen jam nut, use an allen wrench to readjust relief pressure setting if needed, and then retighten jam nut.
7. Reassemble hose from autofeed plus block (or from flow divider) to feedwheel control valve.
8. Check for hydraulic leaks.
9. Relief valve pressure should be checked and/or readjusted every month for best performance.

MAINTAIN FEEDWHEEL HYDRAULIC PRESSURE AT 2500 PSI (172 bar).

PROCEDURE FOR CHECKING OPTIONAL HYDRAULIC COMPONENTS

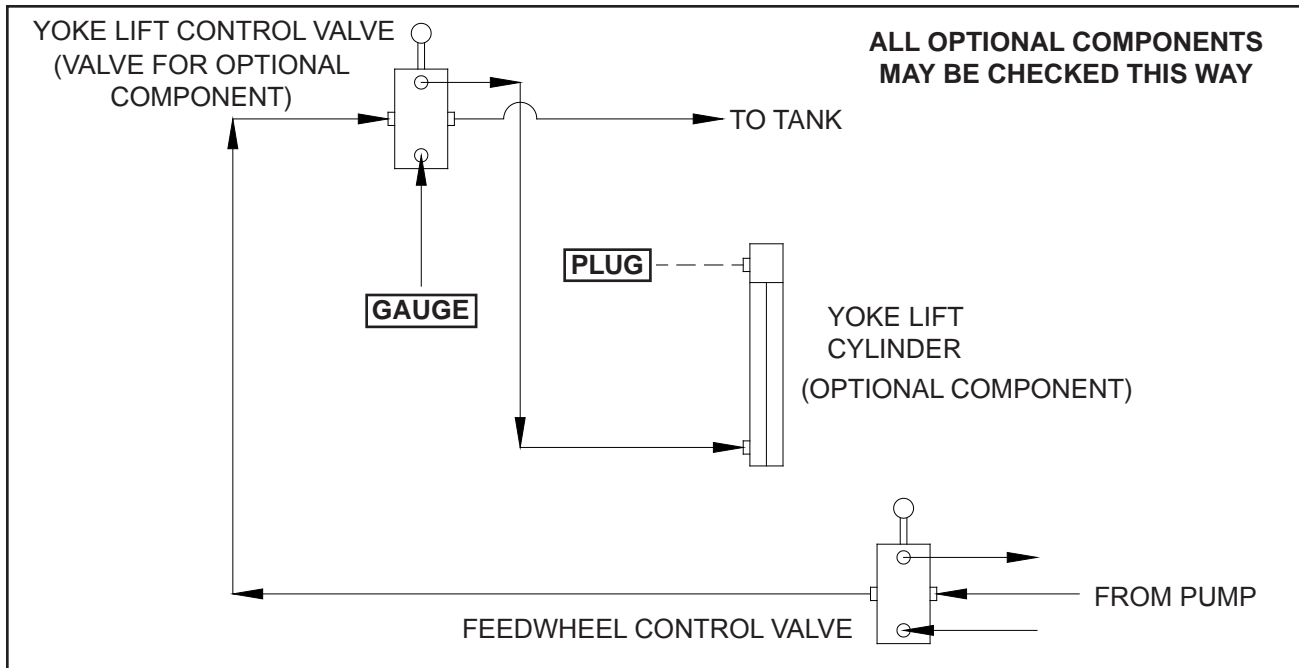

⚠ WARNING

MODELS 1290XP/1590 PROCEDURE

Before attempting any hydraulic pressure settings, make sure engine is shut off, the ignition key is removed and in your possession, hydraulic oil is clean, hydraulic tank is 7/8 full, and the machine has been pre-run to warm the hydraulic oil. To correctly check relief valve pressure, the pressure gauge MUST be installed correctly.

1. First put control handle in off position.
2. Disconnect hose coming out of the port farthest from the handle of the control valve from the optional motor or cylinder, and plug the hose.
3. Leave all other hydraulic hoses connected.
4. Install pressure gauge in the valve port which had the hose of the optional motor or cylinder disconnected.
5. Start engine and adjust engine to full throttle to activate reading on pressure gauge.
6. Only operate the valve for that component to activate pressure gauge. Pressure gauge should read the maximum specified PSI (bar) for that component, see page 56.

ONLY RUN ENGINE FOR 4-5 SECONDS TO SET PRESSURE OR YOU MAY DAMAGE HYDRAULICS.

7. Readjust relief pressure setting if needed, if not needed, shut off engine and remove plug and pressure gauge. Reassemble control valve to optional motor or cylinder.
8. Check for hydraulic leaks.
9. Relief valve pressure should be checked and/or readjusted every month for best performance.

MAINTAIN HYDRAULIC PRESSURE TO THE SPECIFIED PSI (bar).

HYDRAULIC SYSTEM TROUBLE SHOOTING

Before attempting any type of maintenance disengage clutch, turn off engine, wait for the disc/drum to come to a complete stop, install the disc/drum lock pin, disconnect battery, and make sure the ignition key is in your possession!

PROBLEM	POSSIBLE CAUSE	SOLUTION
Feedwheel(s) turn at normal speed but does not chip wood properly	<ol style="list-style-type: none"> 1. Dull Knives 2. Worn feed teeth 3. Low feedwheel relief valve setting 4. Pump is worn 5. Motor is weak 6. Feedwheel springs too loose 	<ol style="list-style-type: none"> 1. Replace knives 2. Replace 3. Readjust to specified PSI (bar) 4. Replace 5. Replace 6. Adjust
Feedwheel(s) slow or stop when feeding	<ol style="list-style-type: none"> 1. Dull knives 2. Relief valve is worn or dirty 3. Pump is worn 4. Motor is worn 5. Feedwheel springs too tight 6. Feedwheel slide box sticking or hanging up 	<ol style="list-style-type: none"> 1. Replace knives 2. Clean, reset or replace 3. Replace 4. Replace 5. Adjust 6. Lubricate
Feedwheel(s) turn slowly or not at all	<ol style="list-style-type: none"> 1. Relief valve stuck open 2. Worn hydraulic motor 3. Pump is worn 4. Feedwheel relief pressure off 5. Pinched or damaged hydraulic hose 6. Feedwheel valve (control valve) worn & leaking internally 7. Low hydraulic oil level 8. Plugged oil screen 9. Binding such as worn bearings, etc. 10. Control lever improperly shifting valve 	<ol style="list-style-type: none"> 1. Clean or replace 2. Replace 3. Replace 4. Reset to specified PSI (bar) 5. Replace 6. Replace 7. Fill 7/8 full minimum 8. Replace 9. Repair 10. Readjust, valve must open completely
Hydraulic oil very hot, causing system to operate slowly	<ol style="list-style-type: none"> 1. Dull knives 2. Low oil level 3. Pump is worn 4. Relief valve stuck open or opens easily 5. Damaged hose 6. Oil suction screen or filter plugged 7. Oil cooler plugged, if equipped 8. Motor is worn 9. Binding 10. Operator running oil over relief too much 	<ol style="list-style-type: none"> 1. Replace knives 2. Fill 7/8 full minimum 3. Replace 4. Clean, reset or replace 5. Replace 6. Clean or replace 7. Clean 8. Replace 9. Repair 10. Don't

MAINTAIN FEEDWHEEL HYDRAULIC PRESSURE AT 2500 PSI (172 bar).

Follow typical hydraulic flow and relief settings on pages 56 - 61.

Follow proper hydraulic oil requirements on page 54 - 55.

CORRECTING HYDRAULIC PROBLEMS

Before attempting any type of maintenance disengage clutch, turn off engine, wait for the disc/drum to come to a complete stop, install the disc/drum lock pin, disconnect battery, and make sure the ignition key is in your possession!

COMPONENT	PROCEDURE
Checking relief valve setting	Refer to the hydraulic pressure adjustment procedure section of the manual to find the correct procedure for checking relief valve setting. (pgs. 58 - 61)
Adjusting relief valve setting	Refer to the hydraulic pressure adjustment procedure section of the manual to find the correct procedure for adjusting relief valve pressure settings. (pgs. 58 - 61)
Cleaning relief valve (with engine shut off)	<ol style="list-style-type: none"> 1. Remove plug from feedwheel valve (control valve), see illustration of relief valve components. (pg. 58) 2. Unscrew slotted set screw completely out of the valve. 3. Remove poppit spring. 4. Remove poppit ball. 5. Clean all parts, inspect for damage and blow out relief hole with air. 6. Reassemble, set and maintain feedwheel hydraulic pressure at 2500 PSI (172 bar).
Checking for defective pump	<ol style="list-style-type: none"> 1. See pages 64-65 on how to check a hydraulic pump.
Checking for defective motor	<ol style="list-style-type: none"> 1. If everything checks out as correct, it may be time to check the hydraulic motor. 2. If your machine has Live Hydraulics, see page 66 on how to check a hydraulic motor. 3. If your machine does not have Live Hydraulics, contact your local dealer or Bandit Industries for instructions.

NOTE: When returning hydraulic components for warranty make sure to box up all warranted parts to avoid additional damage while shipping. **Do not disassemble any hydraulic components which are to be warranted.** Anything which has been disassembled or tampered with will not be warranted. Items being returned must be clean. All hydraulic components must have all hosing ports plugged. Failure to plug ports will allow debris to enter components which will void warranty.

MAINTAIN FEEDWHEEL HYDRAULIC PRESSURE AT 2500 PSI (172 bar)

Follow typical hydraulic flow and relief settings on pages 56 - 61.
Follow proper hydraulic oil requirements on page 54 - 55.

HYDRAULIC PUMP CHECK OUT

HYDRAULIC PUMP CHECK OUT WITHOUT USING A FLOW METER

To check out the hydraulic pump the mechanic will need a needle type flow control valve, a pressure gauge capable of reading 3000 psi (207 bar) and a long enough hose that will span between the pump and the hydraulic tank.

- 1) Disconnect the pressure line going from the pump at the first component and cap the fitting at the component.
- 2) Attach a Tee fitting to the end of the pressure hose (which was removed from the component) and install the Tee fitting and gauge.
- 3) Attach the hydraulic flow control valve to the Tee fitting and the hose (you supply) to the outlet port of the flow control valve.
- 4) **Make sure the pressure gauge is installed up stream from the flow control valve. Failure to do this will cause serious damage to the hydraulic pump when testing.**
- 5) If the hydraulic oil tank is equipped with a mesh strainer in the fill neck, remove it and place the open end of the hose (you supply) into the tank fill neck.
- 6) **MAKE SURE THAT THE FLOW CONTROL VALVE IS FULLY OPEN SO AS TO ALLOW UNRESTRICTED FLOW TO PASS THROUGH IT.**
- 7) Start the engine to engage the pump, the clutch may have to be engaged if the pump is belt driven.
- 8) Have a second person lift the hydraulic hose far enough out of the tank inlet to observe the flow of oil going into the tank. Observe the pressure gauge reading to make sure a high pressure does not exist.
- 9) Increase the engine speed slowly to full rpm and at the same time observe the pressure. This should still remain low.
- 10) **SLOWLY** turn the needle valve on the flow control in and observe the pressure increase on the pressure gauge.
- 11) Continue closing the flow control valve until the pressure gauge reading reaches 90% of the normal relief valve setting (example: if system operates at 2500 psi (172 bar), do not exceed 2250 psi (155 bar). **Never allow the pressure to go more than 90% of the main relief pressure.**
- 12) If the pump is good there should be no noticeable decrease in the flow rate coming out of the hose and into the hydraulic tank.
- 13) If 90% of the main relief pressure can not be obtained and/or the flow rate of the hose is considerably less, then the pump is worn or damaged.

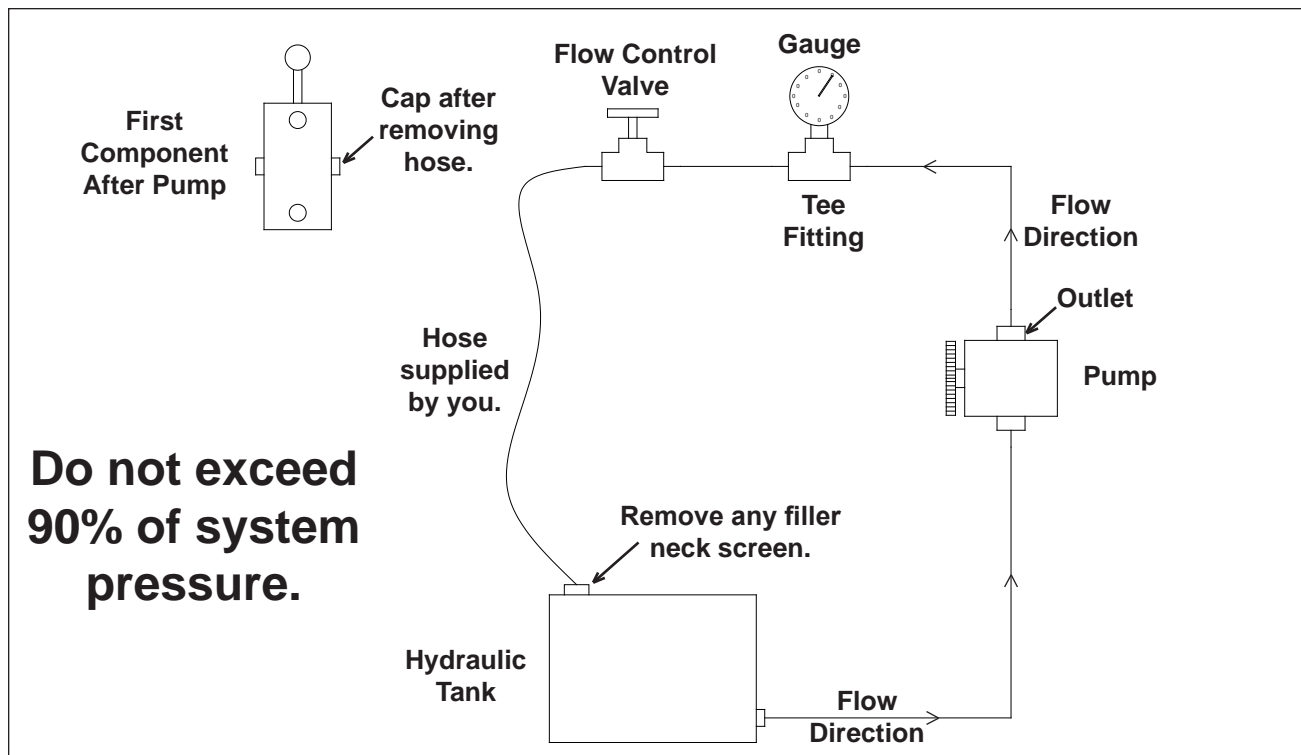

HYDRAULIC PUMP CHECK OUT

HYDRAULIC PUMP CHECK OUT USING A FLOW METER

To check out the hydraulic pump the mechanic will need a needle type flow meter capable of reading 3000 psi (207 bar) and a long enough hose that will go from the flow meter back to the first component.

- 1) Disconnect the pressure line going from the pump at the first component.
- 2) Attach the flow meter to the end of the pressure hose (which was removed from the component).
- 3) Attach the hose you supplied to the outlet of the flow meter and run the hose back to the first component. **MAKE SURE THE HOSES ARE ON THE CORRECT SIDES OF THE FLOW METER.**
- 4) **Make sure the pressure gauge is installed up stream from the flow control valve. Failure to do this will cause serious damage to the hydraulic pump when testing.**
- 5) **MAKE SURE THAT THE FLOW CONTROL VALVE IS FULLY OPEN SO AS TO ALLOW UNRESTRICTED FLOW TO PASS THROUGH IT.**
- 6) Start the engine to engage the pump, the clutch may have to be engaged if the pump is belt driven.
- 7) Observe the flow rate through the meter and pressure gauge reading to make sure a high pressure does not exist.
- 8) Increase the engine speed slowly to full rpm and at the same time observe the pressure and flow rate. The pressure should still remain low. Make a note of the flow rate (gpm or Lpm) at full engine rpm.
- 9) **SLOWLY** turn the needle valve on the flow control in and observe the pressure increase on the pressure gauge.
- 10) Continue closing the flow control valve until the pressure gauge reading reaches 90% of the normal relief valve setting (example: if system runs at 2500 psi (172 bar), do not exceed 2250 psi (155 bar). **Never allow the pressure to go more than 90% of the main relief pressure.**
- 11) If the pump is good, you should have at least 80% of the flow rate (gpm or Lpm) passing through the flow meter as noted at low pressure and full rpm (example: 10 gpm (38 Lpm) and low pressure = 8 gpm (30 Lpm) at 90% pressure).
- 12) If 90% of the main relief pressure can not be obtained and/or the flow rate passing through the meter is considerably less, then the pump is worn or damaged.

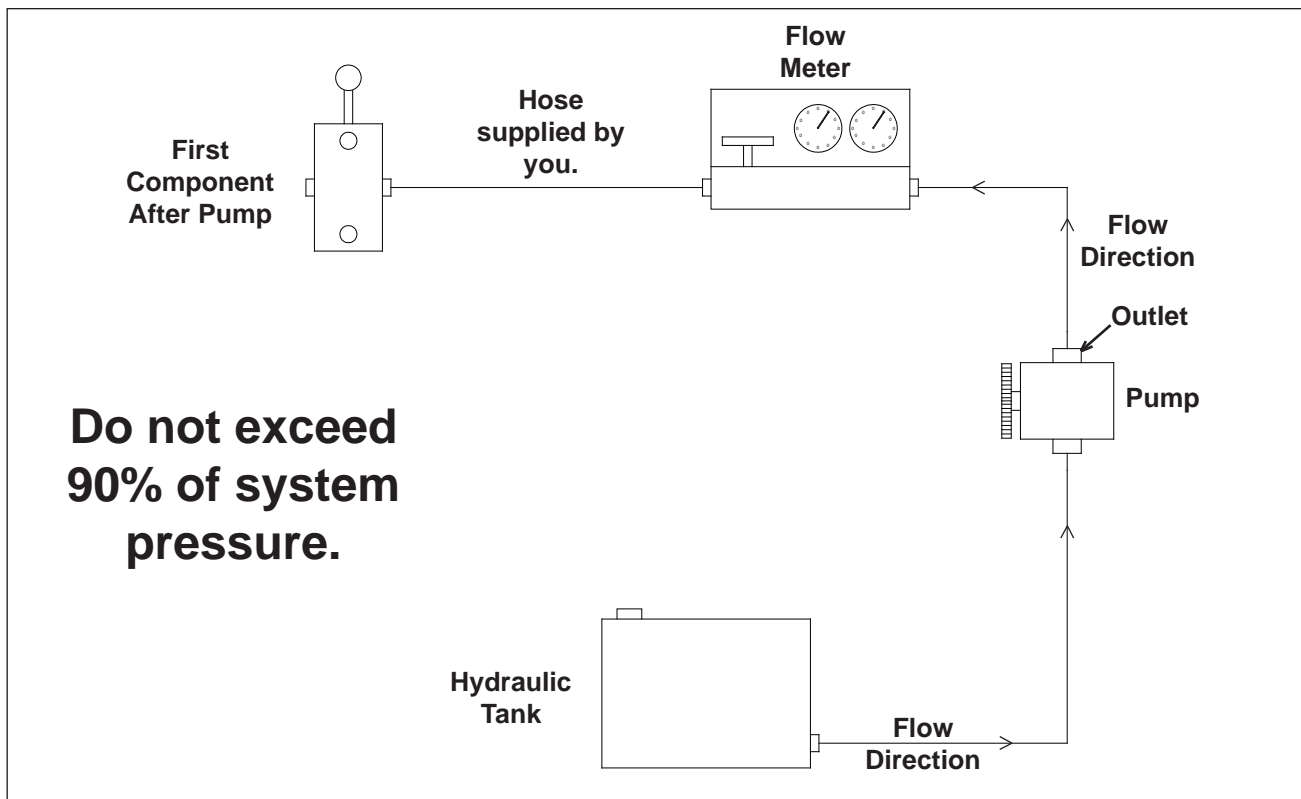

HYDRAULIC MOTOR CHECK OUT

HYDRAULIC MOTOR CHECK OUT FOR MACHINES WITH LIVE HYDRAULICS

To check out a hydraulic motor the mechanic will need a pressure gauge capable of reading 3000 p.s.i. (207 bar), a Tee fitting to install in the control valve, a plug fitting to install in the control valve and a clean 5 gallon (19L) pail.

- 1) The following instructions are for machines with Live Hydraulics, for machines without Live Hydraulics contact your local dealer or Bandit Industries.
- 2) In order to check out a hydraulic motor, it is necessary to mechanically stop the motor from turning while under load. The hydraulic pump needs to be driven without turning the chipper disc/drum (Live Hydraulics). Feed a reasonably large size log into the machine until it contacts the stationary disc/drum. This should stall the hydraulic motor(s). It may also be necessary to apply down pressure by operating the yoke control valve (if equipped).
- 3) With the feedwheel(s) mechanically locked as described and the engine turned off, unhook the hose going from the hydraulic motor back to the control valve at the valve. Some machines will be equipped with a flow divider between the hydraulic motor and the control valve.
- 4) Place the end of the hose in a clean 5 gallon (19L) pail.
- 5) Plug the open port in the control valve.
- 6) Unhook the other hose in the control valve and install a Tee fitting into the control valve and attach the hose to the Tee fitting.
- 7) Install a pressure gauge in the other port in the Tee fitting to monitor hydraulic pressure.
- 8) Put the infeed control valve in the center position and start the engine.
- 9) Increase the engine speed slowly to full rpm.
- 10) Operate the infeed control valve to feed the log into the stationary disc/drum. If the feedwheel(s) try to turn, apply down pressure by using the yoke control valve (if equipped).
- 11) Providing the pump and the relief are functioning properly, the pressure gauge should read the specified main relief setting.
- 12) Observe the amount of hydraulic fluid coming from the hose into the pail. The amount of leakage should not be more than about 1 g.p.m. (3.8 L.p.m.) into the pail.

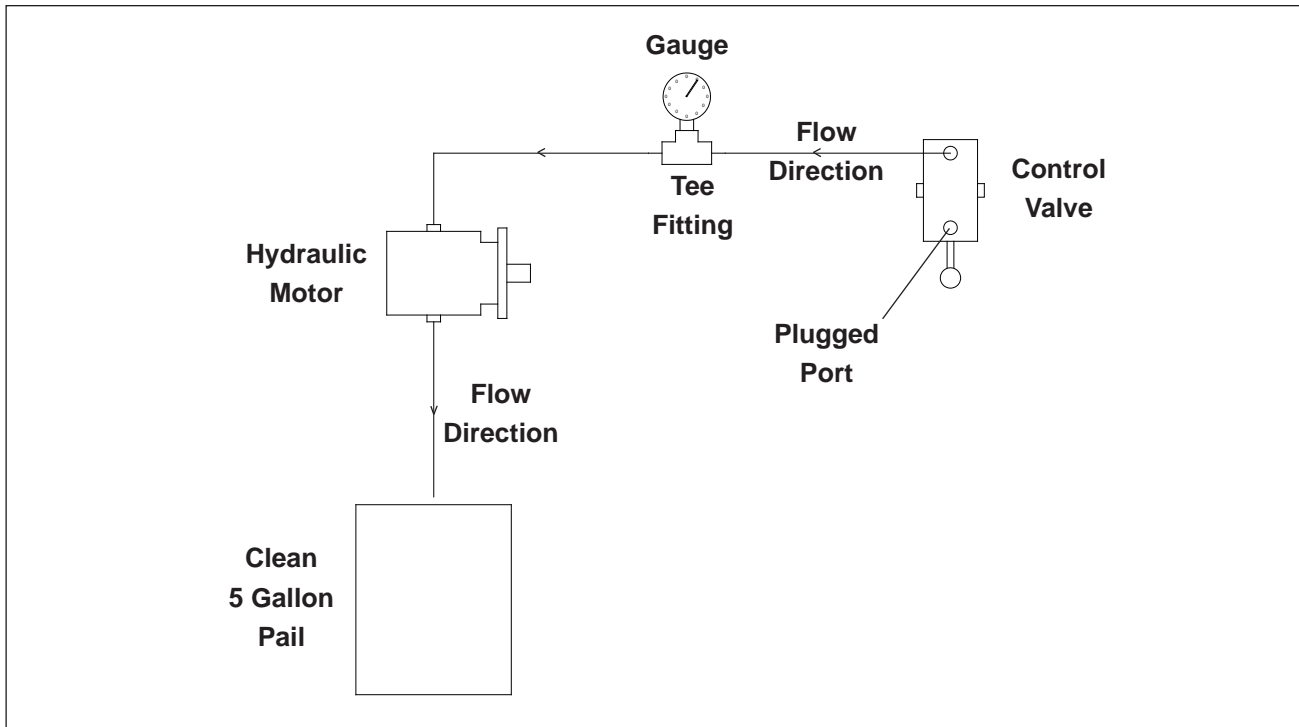

CONTROL VALVE DETENT ASSEMBLY AND O-RING REPLACEMENT

Tools Required:

- Small amount of clean hydraulic oil
- Clean working area, free of debris and shop rags
- 3/16" Tee handle hex driver
- 1/2" drag link drive socket
- jawed vice

General Procedure:

Disassembly:

- 1) Secure valve in vice or suitable method to firmly hold valve.
- 2) Note the orientation and placement of all components during disassembly.
- 3) Using the 3/16" Tee handle hex driver, remove (2) two socket head cap screws which holds the spring cover to the valve body. Set aside for re-use.
- 4) The detent assembly is now visible. Insert the 1/2" drag link drive socket blade into slot of retaining screw. Loosen and remove the retaining screw along with the entire detent assembly.
- 5) With the 3/16" Tee handle hex driver, remove (2) two socket head cap screws that hold the control lever assembly to the valve body.
- 6) Detach hand lever from spool. Carefully remove valve spool from valve body. Take care not to scratch, dent, or nick the spool. Note the orientation of handle attachment point on spool. Set aside for re-use.
- 7) Remove (2) seal retainers, o-rings, and back-up rings from both ends of the valve.
- 8) Inspect and replace o-ring and back-up ring if cut, or if leak is suspected.

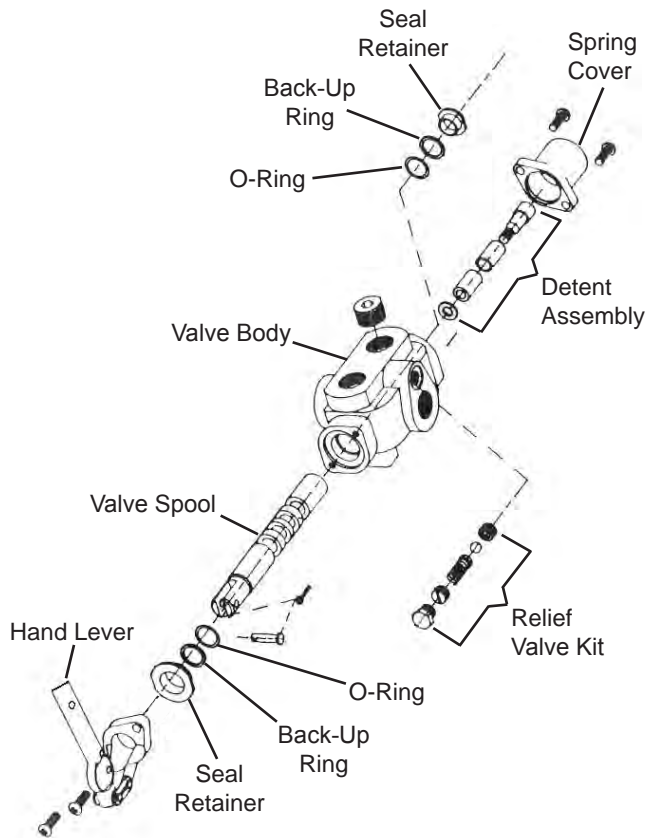

Assembly:

- 1) Lubricate spool, o-rings, and back-up rings with clean oil. Insert spool and center it in the valve body.
- 2) Place the new o-rings and back-up rings over spool ends and seat them into the valve body. Seat the seal retainer onto back-up ring making sure not to pinch the o-ring or back-up ring against the valve body.
- 3) Re-attach the hand lever to the spool. Mount control lever assembly onto the valve body using the (2) two socket head cap screws.
- 4) Thread a new detent assembly onto the spool end and hand tighten with the 1/2" drag link drive socket blade. No additional lubricant is required.
- 5) Mount the spring cover and the (2) socket head cap screws.
- 6) Hand tighten all (4) four socket head cap screws with the 3/16" Tee handle hex driver.
- 7) Shift valve with hand lever to assure operation. With some effort, the hand lever should move between three positions. The detent will hold the hand lever in the three positions.

Instructions and illustrations provided by component manufacturer.

SPECIFIC SCHEMATIC FUNCTION MAY VARY DEPENDING ON OPTIONS OR COMPONENT MANUFACTURE.

WITH NO OPTIONS

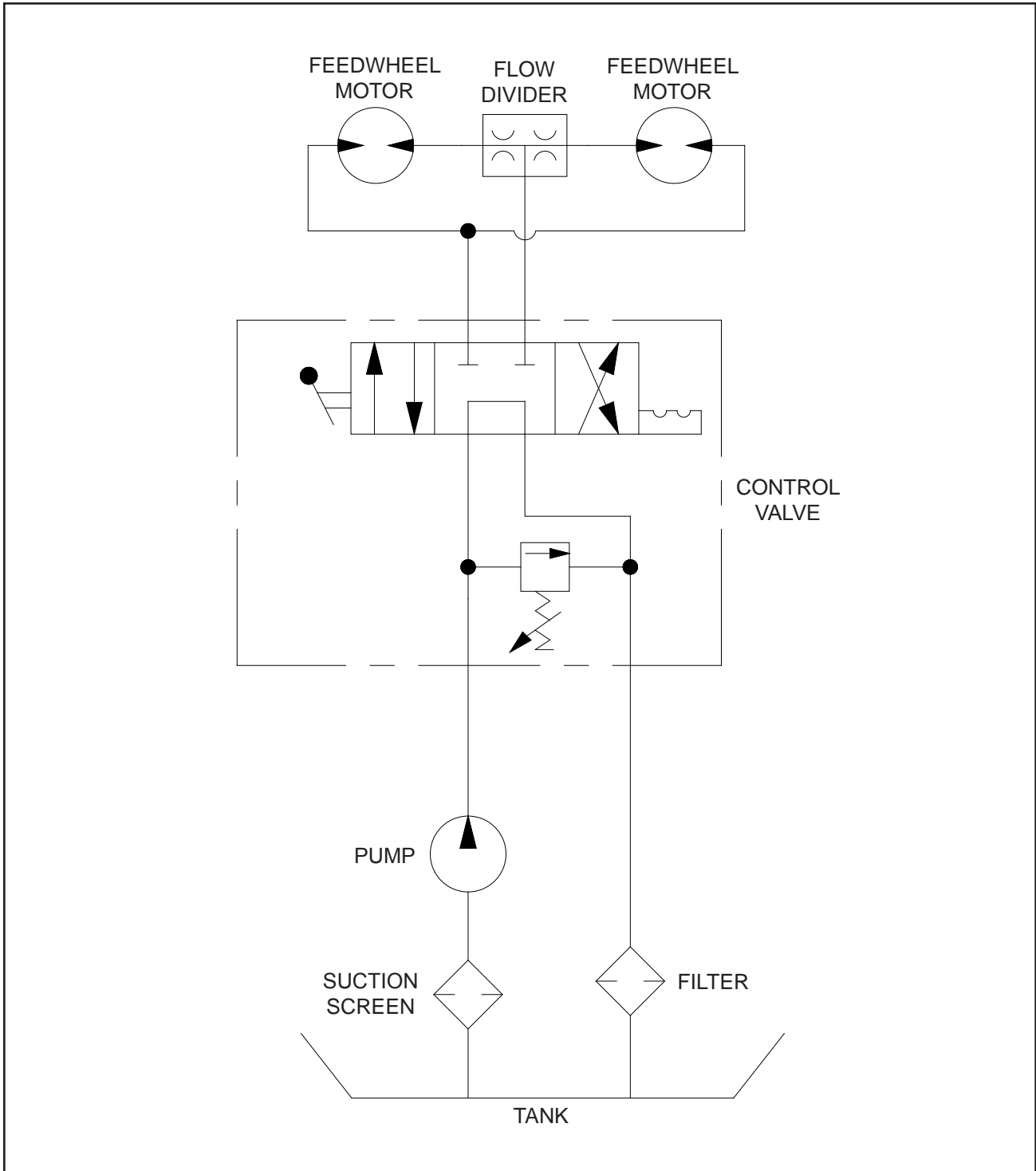

SPECIFIC SCHEMATIC FUNCTION MAY VARY DEPENDING ON OPTIONS OR COMPONENT MANUFACTURE.
WITH AUTOFEED PLUS, YOKE LIFT CYLINDER, AND WINCH

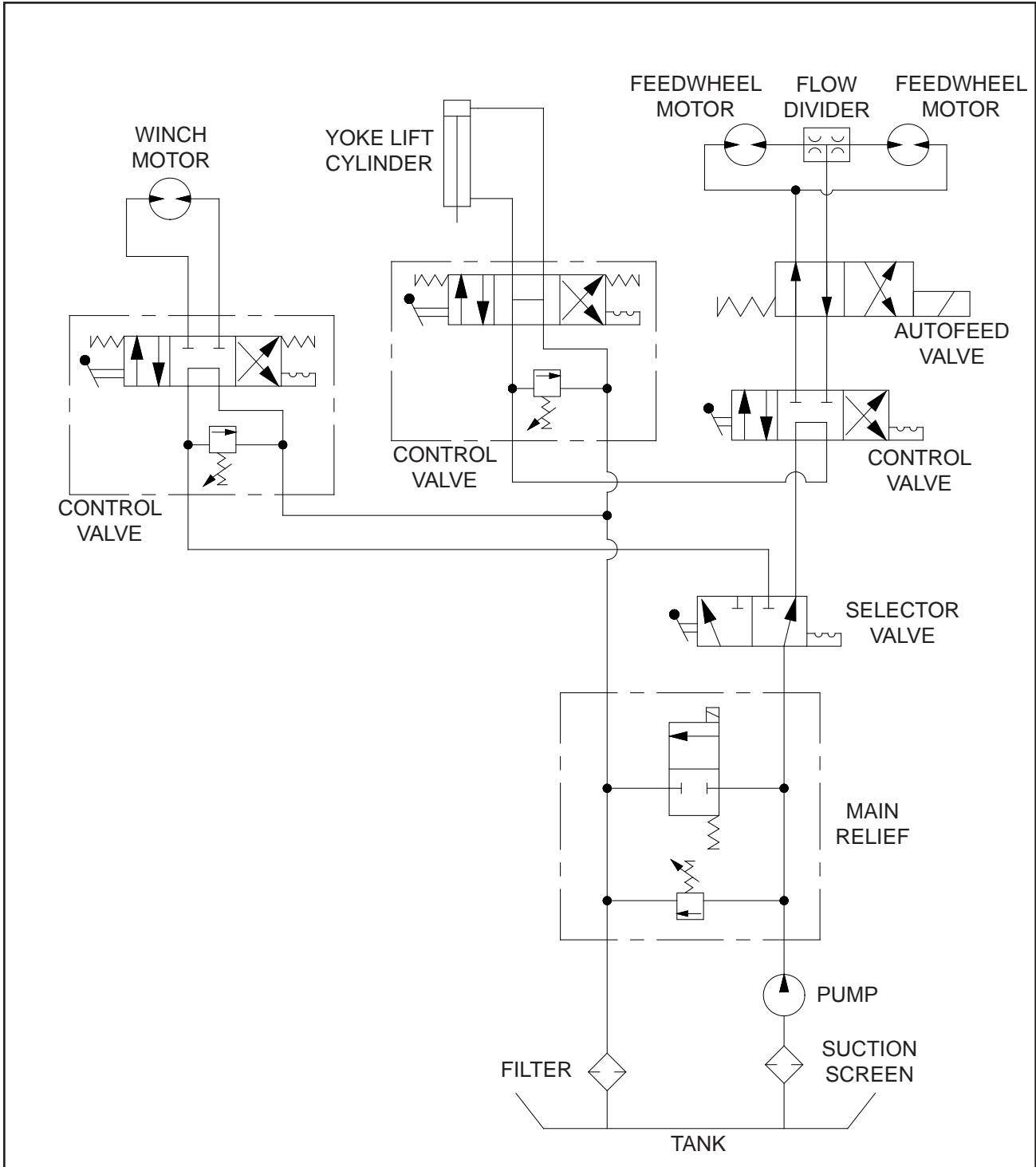

CHIPPER SECTION

Knives should be replaced in sets. These sets are determined by the amount of resharpening done to the knives. It should be reinstalled with another knife of comparable usage. It helps to keep the disc/drum balanced, and it helps maintain chip quality.

NEVER allow these knives to wear beyond absolute specified minimum distance from the center line of bolt.

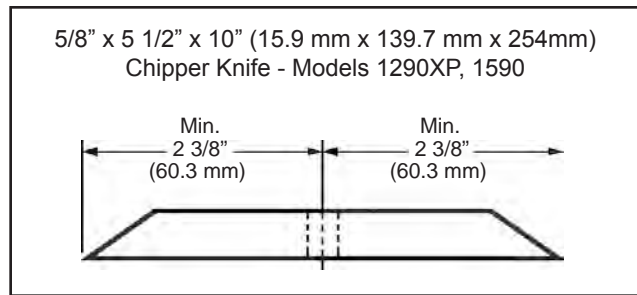

TROUBLE SHOOTING CHIPPER PROBLEMS

- 1) **Chipper Makes Poor Quality Chips or Does Not Feed Properly.**
 - A. Knives have lost their edge. File, grind or replace knives. **DO NOT** operate the Bandit with dull knives.
 - B. Knife anvil worn or needs adjustment. Rotate, repair or replace (see below).
 - C. Feedwheel(s) are not operating correctly. (SEE HYDRAULIC TROUBLE SHOOTING).
 - D. The throat/base opening is a high-wear area. The feed plate anvil takes much of this wear but other areas wear as well. Attention must be paid to any areas where outer, noncutting edges of chipper knife are exposed. These areas must be built up with weld to maintain the original integrity.
 - E. Knives are at the wrong angle. Knives must be ground at a 30° to 30 1/2° angle.
 - F. Feedwheel teeth worn (REPLACE).
 - G. Material being chipped is very small, dry or rotting. This type of material does not produce good chip quality.

- 2) **Chipper Knife Hits Anvil.**
 - A. Check the anvil clearance at both sides of the knife by using a feeler gauge, the clearance should be approximately .120" (3.0 mm) from the highest knife.
 - B. Check the chipper bearing bolts for tightness (SEE TORQUE CHART).

- 3) **Discharge Plugs or Does Not Throw Chips Properly.**
 - A. Lugging engine on large material - keep engine RPM up.
 - B. Knives are dull or worn to minimum size.
 - C. Obstruction in discharge chute. Patches welded into the chute can cause obstruction of chip flow. Anything causing an obstruction will cause the chute to plug.
 - D. Chipping rotting material that has little substance can also plug the discharge chute.
 - E. Worn fan blades.
- 4) **Chipper Bearings Running Too Hot.**
 - A. Improper lubrication - purge bearings once a day with EP-2 Lithium type grease.
 - B. Chipper drum operating at too high RPM's. **DO NOT** exceed recommended RPM's.
 - C. Bearings worn out (REPLACE).
 - D. Bearing locknut is loose.

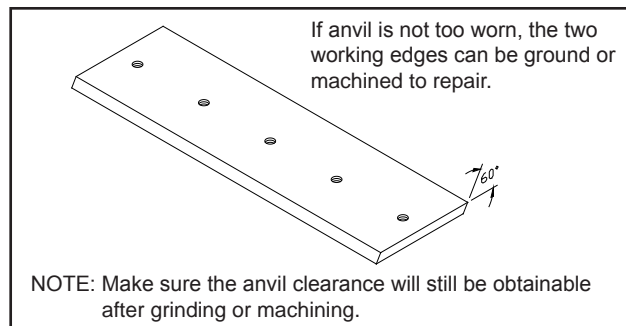

KNIFE GRINDING AND FILING

Only Bandit knives and hardware are recommended for use in your Bandit chippers. Only then can you be assured of a quality product that fits and performs the best to the standards of excellence that is expected from the Bandit chipper.

Chipper knives **MUST** be kept sharp at all times for the ultimate chipper and knife performance. The main cause of poor cutting performance is dull knives.

Dull Knives Cause:

- Excessive waste of engine horsepower
- Bad quality chips; chunks, slivers, etc.
- Excessive strain on knives and mounting hardware
- Excessive strain on chipper disc/drum bearings and total machine
- Excessive chipping vibration damaging the machine
- Excessive strain on drives, PTO's, engines, etc.
- Increase the probability of the discharge plugging and decreases the throwing distance
- Loss of time and money

The Dulling Of Chipper Knives Is Caused By:

- Poor quality knives
- Improper anvil to knife clearance
- Force feeding wood faster than chipper will accept
- Dirt, grit, or foreign material on the wood
- Chipper knives ground at wrong angle
- Improper care of knives and knife hardware

These are just a few factors, there are other situations that can lead to the dulling of chipper knives.

NOTICE

Many times a chipper knives cutting edge/point can be brought back to a good edge with a #10 Flat Bastard Mill File. This can reduce the amount of regrinding.

Typical Knife Grinding Angles:
 "Bolt-In" Knives = 30° to 30 1/2° Angle

Knives should be replaced in sets. These sets are determined by the amount of resharpening done to the knives (knife width). Regrinding knives reduces the width of the knife. Knife replacement should be done in sets of the same width knives. That will reduce chipping vibration and increase chipping performance.

NOTICE

- Keep knives sharp.
- Keep knife angle correct when grinding.
- Do not over grind so knife is narrower than allowed width, or you will pack wood and break knives.
- Use correct knife size, knife quality, knife mounting hardware, and torque knife mounting hardware to the specified torque.
- Replace knife mounting hardware after (5) times of tightening.

CAUTION

Do not grind the knives in a direction which produces a radius, or hollow grind, on the surface of the knife. Strength and life of the cutting edge is reduced.

- For maximum chipper efficiency, the original cutting angle must be maintained when the knives are sharpened. The knives should be machine ground to produce a flat, straight edge.
- Knives may be sharpened repeatedly as long as their original width is not reduced to less than the specified minimum width. If a knife measures less than the specified minimum width after sharpening, it must be discarded.
- Sharpening techniques should be the same as those employed for any high carbon steel cutting edge. Use a coolant and exercise care not to draw temper or crack the cutting edges by excessive heating.
- Inspect the knives after grinding to ensure the knives are free of cracks.
- Maintain spare sharpened knives to avoid downtime for knife sharpening.

NOTICE

USE CORRECT KNIFE AND HARDWARE

DO NOT use a size or style chipper knife, bolt or nut other than factory approved for this chipper - see manual.

DO NOT over torque or under torque knife bolts and nuts - see manual.

DO NOT resharpen knife more than minimum width - see manual.

DO NOT use a knife bolt or nut which has been tightened over (5) times - replace.



DO NOT improperly install the knife nuts. Flat surface of nut goes toward the chipper disc.

KNIFE CHANGING PROCEDURE

Only Bandit knives and hardware are recommended for use in your Bandit chippers. Only then can you be assured of a quality product that fits and performs the best to the standards of excellence that is expected from the Bandit chipper.

DANGER

Chipper knives are sharp and can be dangerous. It is always necessary for your protection to be extra careful and wear leather gloves when handling knives. Before changing knives make sure all shut down procedures are followed.

1. Before attempting any type of maintenance disengage clutch, install clutch lock if equipped, turn off engine, wait for the disc/drum to come to a complete stop, install the disc/drum lock pin, disconnect battery, and make sure the ignition key is in your possession.
2. Disconnect the chipper hood engine disable plug.
3. Remove the padlock from the hood pin.
4. On disc chippers, recess the spring lock for the hood pin and retract the hood pin. On drum chippers, retract the hood pin.
5. Carefully open the hinged part of the chipper hood. Do not slam the chipper hood to the open position. This will cause damage to the hinge. If the hinge becomes damaged by slamming the hood open, replace the hinge immediately! If the hinge has become damaged, it will cause misalignment of the hood, the chipper disc/drum may hit the hood and cause a serious accident!
6. Changing the chipper knives is a two person job. One person, using a wooden block, holds the chipper knife in place while the other person removes the chipper knife hardware. Remove all of the knives in each pocket. If the machine is a disc chipper with 5/8" knife bolts, typically a 3/8" allen key and a 1 1/16" socket is required to change or torque the knife hardware. If the machine is a disc chipper with 1/2" knife bolts, typically a 5/16" allen key and a 7/8" socket is required to change or torque the knife hardware. If the machine is a drum chipper, typically a 15/16" socket is required to change or torque the knife hardware.
7. Once the knives have been removed, inspect the knife pocket. Check for secure welds, excessive wear, impact cracks, and elongated bolt holes on disc chippers or the condition of the knife bolt threads on drum chippers. If a problem is found, contact your local dealer or Bandit Industries.
8. Clean out the knife pocket at this time. Remove all debris from the pocket and knife bolt holes.
9. Sharpen, rotate, or replace the chipper knife. Knives should be professionally ground, maintaining angle and dimensional specifications. Knives should be replaced in sets. These sets are determined by the amount of resharpening done to the knives. It should be reinstalled with another knife of comparable usage. It helps to keep the disc/drum balanced, and it helps maintain chip quality. Do not allow the knives to wear beyond the absolute minimum specified distance from the center line of the bolt hole. Reinstall the chipper knives. Make sure to properly torque the knife hardware, see Bolt Torque Chart. Knife mounting hardware must be replaced after maximum of 4 - 5 knife rotations/changes to insure safe clamping ability. All knives and knife mounting hardware must be factory approved.
10. Remove the disc/drum lock pin. Very carefully, manually with a bar, turn the chipper disc/drum to the next knife pocket. Reinstall the disc/drum lock pin.
11. Repeat steps 6 through 10, for each knife pocket.
12. Once the knives have been changed or rotated, check the anvil clearance. Make sure the clearance is maintained to the specified distance from the highest knife. Do Not under any circumstance attempt to rotate the chipper disc/drum while someone is inside the infeed hopper. They may become seriously injured, Do Not Do This!
13. Close the hinged part of the chipper hood and reinstall the hood pin, hood pin padlock, chipper hood disable plug, and on disc chippers make sure the spring lock for the hood pin springs back into position.

Bandit

LUBRICATION & COOLANT

1) Engine:

Follow original equipment manufacturer's requirements for both changing oils and filters, refer to engine manual specifications.

2) Engine Coolant:

Refer to engine manufacturer's manual specifications.

3) Clutch:

Follow original equipment manufacturer's requirements for both greasing and adjusting. Frequently, adjust and lubricate per PTO manufacturer's manual.

4) Wheel Bearings:

Follow axle manufacturer's instructions for greasing or oiling wheel bearings.

5) Hydraulic Reservoir Tank:

Completely change hydraulic oil, suction screen(s), and flush the tank annually. Change hydraulic oil filter(s) AFTER FIRST 10 HOURS OF OPERATION. Then change hydraulic oil filter(s) every 3 months or 400 hours thereafter. Maintain hydraulic oil level 7/8 full. See hydraulic oil requirements below. Check hydraulic oil level in tank daily.

6) High Pressure Filter(s) (if equipped):

If machine is equipped, change high pressure oil filter(s) AFTER FIRST 10 HOURS OF OPERATION. Then change high pressure oil filter(s) every 3 months or 400 hours thereafter.

7) Hydraulic Fluid Requirements:

See pages 54 - 55 for hydraulic fluid requirements.

8) Discharge Swivel:

Grease swivel plates for discharge as needed.

9) Hood Hinge:

Make sure the hood hinge operates correctly, and is lubricated. Must replace hinge if damaged.

10) Pivoting And Hinged Areas:

Lubricate all pivoting and hinged areas weekly. (i.e. control handle, discharge flipper, etc.)

11) Pintle Eye Ring:

Keep greased to reduce wear and extend the normal life of your pintle eye ring.

12) Chain Operated Components:

Use a dry lubricant on any chain driven components weekly. (i.e. hydraulic swivel discharge, or chain driven feedwheels)

13) Chipper & Feedwheel Bearings:

Use an EP-2 Lithium type grease only for all bearings. Purge chipper bearings with grease you can not over grease these bearings. Grease feedwheel bearings with one shot of grease. Both types of bearings are designed with a relief system that will not allow over greasing. In other words, you can not hurt the bearing seals by pumping in too much grease. Wipe off excess grease. **Excessive grease will attract dirt.**

Most of the failures related to bearings are diagnosed as "Contamination". Contamination is caused by improper lubrication.

Especially important is proper lubrication when the chipper is setting idle. The bearings must be fully purged when shut down. Then the bearings must be again fully purged each thirty (30) days and the machine allowed to run for approximately 10 minutes. Then fully purged again before the machine is put back into operation. Failure to do this will ruin the bearings. Bearings corrode when the machine is setting idle.

The second largest cause of bearing failure is operating them at high speeds when the grease is cold. This causes the bearing race to turn on the shaft. Naturally this ruins the bearing as well as the shaft. Allow the bearings to turn at slower speeds for at least five minutes. Also check the bearing lock collar set screws or bearing locknut for tightness each 30 days. Loose set screws or locknut allows the race to turn on the shaft. Failed bearings diagnosed as contamination or cold starts at high speed are not covered by warranty of the bearing manufacturer.

14) Feedwheel Slide Box:

Check that feedwheel slide box is working smoothly, oil with 10W/30 type motor oil weekly. Especially new machines need oiling to ensure correct operation during break-in.

15) "Bandit Lever Throttle Cable (if equipped):

If the machine is equipped with a "Bandit" lever throttle system, lubricate inner throttle cable and cable ends with a cable lube or SAE 10W/30 oil every month. Replace throttle cable if it doesn't operate smoothly.

TYPICAL ELECTRICAL WIRING DIAGRAMS

WIRING FOR STANDARD 6 PRONG PLUG AND 6 WIRE MAIN CABLE EFFECTIVE ON MACHINES BUILT AFTER 11/01/04

6 Wire Main Cable Color Code
 Red R (Brakes & Breakaway Switch)
 White W (Ground)
 Green G (Right Turn)
 Yellow Y (Left Turn)
 Brown BR (Running Lights)
 Black BL (Power to Breakaway Switch)

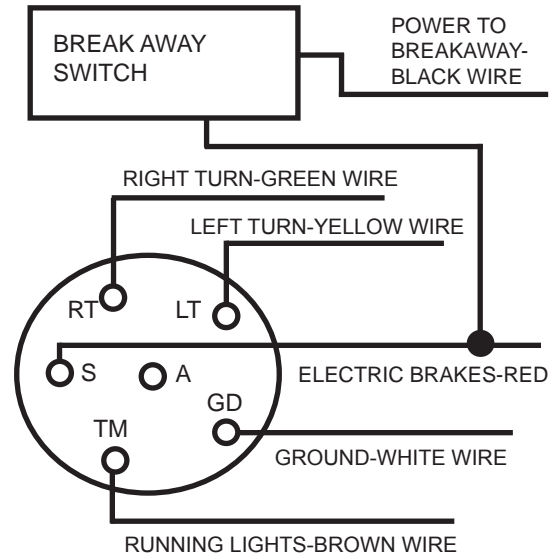

J JUNCTION BOX
 WIRES SPliced TOGETHER
 WHITE WIRES GROUNDED

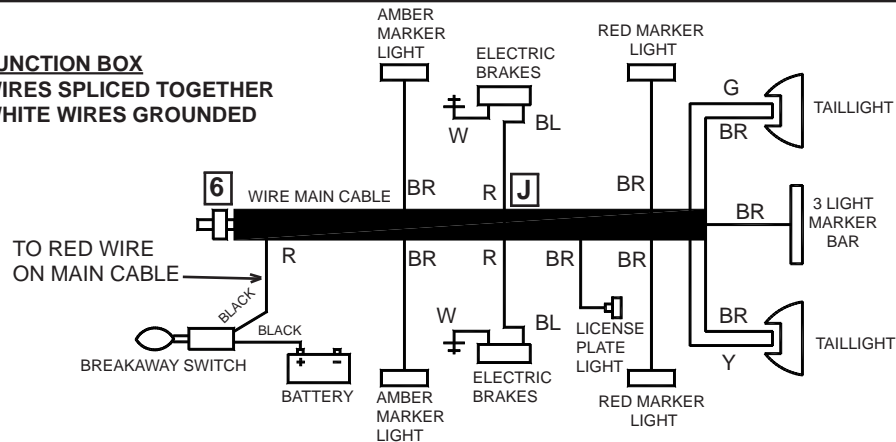

6 WIRE MAIN CABLE COLOR CODE (OLD STYLE)

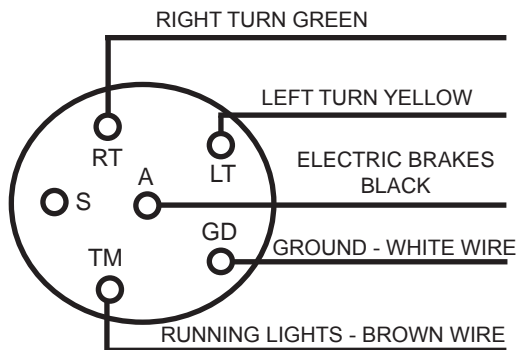

OLD STYLE

6 Wire Main Cable Color Code

Black BL (Brakes)
 White W (Ground)
 Green G (Right Turn)
 Yellow Y (Left Turn)
 Brown BR (Running Lights)
 Red R (Breakaway Switch)

REPLACEMENT PARTS SECTION

Depending on what replacement parts you are ordering the following information will be needed:

CHIPPER COMPONENTS

Serial Number
Model Number of Chipper

ENGINE COMPONENTS

Brand
Engine Serial Number
Engine Spec. Number

CLUTCH COMPONENTS

Brand
Serial Number
Assembly Number of Clutch

NOTE

When ordering any replacement parts you should have the serial number (S/N) and model of the machine to ensure that you receive the correct replacement part. See page 6 for typical serial number & work order number locations.

NOTE

All nuts, bolts, washers, and many other components can be ordered by physical description.

NOTE

Some of the components shown in this section are for optional equipment and may not apply to every machine.

Bandit Industries Inc. reserves the right to make changes in models, size, design, installations and applications on any part without notification.

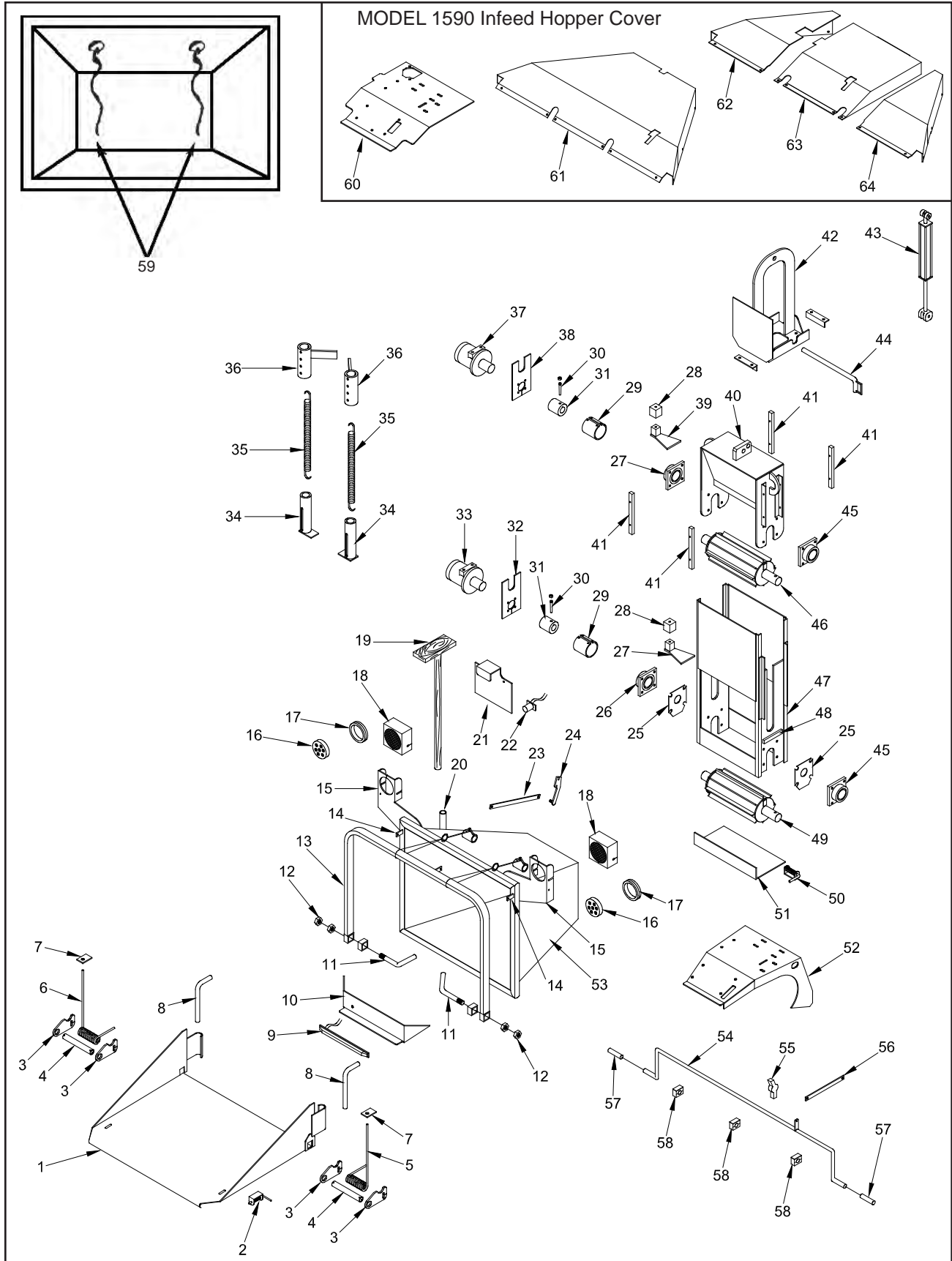

NOTE: Parts may not be exactly as shown.

Bandit

MODELS 1290XP/1590

INFEED HOPPER COMPONENTS

LOCATION	MODEL 1290XP PART NUMBER	MODEL 1590 PART NUMBER	DESCRIPTION
1.	912-200002	981-200028	30" Folding Pan For Infeed Hopper
2 a.	900-4904-90	900-4904-90	Folding Pan Spring Lock - 3/4" Diameter Pin
b.	900-4901-83	900-4901-83	Folding Pan Spring Lock - 1/2" Diameter Pin
c.	900-7900-96	900-7900-96	Rubber Cap For Spring Lock - 3/4" Diameter (Not Shown)
d.	900-7900-93	900-7900-93	Rubber Cap For Spring Lock - 1/2" Diameter (Not Shown)
3 a.	980-300320	980-300320	Spring Mount For Spring Assist - 2" x 3" Tube Bottom Infeed Rim
b.	911-1001-26	980-0129-66	Spring Mount For Spring Assist - 1" x 2" Tube Bottom Infeed Rim
4 a.	980-0129-86	980-0129-86	Spring Tube For Spring Assist
b.	900-4905-45	900-4905-45	Cotter Pin For Spring Tube
5 a.	900-4905-40	900-4905-40	Right Spring For Spring Assist
b.	980-0509-56	980-0509-56	Spring Assist Kit (Includes 3 Through 7)
6 a.	900-4905-39	900-4905-39	Left Spring For Spring Assist
b.	980-0509-56	980-0509-56	Spring Assist Kit (Includes 3 Through 7)
7.	980-0133-34	980-0133-34	Top Spring Block
8 a.	955-300086	955-300086	Folding Pan Lock Pin
b.	900-7900-96	900-7900-96	Rubber Cap For Lock Pin (Not Shown)
9.	900-2909-93	900-2909-93	LED 3 Light Bar
10.	980-300118	980-300118	Mount For LED 3 Light Bar
11.	912-1001-15	955-1007-66	Pivot Pin
12.	900-4900-44	900-4900-44	Pivot Pin Jam Nut
13.	912-1001-10	980-300001	Control Handle
14 a.	980-300302	980-300302	Folding Pan Lock Tab For 3/4" Diameter Pin
b.	955-1005-28	955-1005-28	Folding Pan Lock Tab For 1/2" Diameter Pin
15 a.	980-200176	980-200176	Tail Light Mount - Road Side
b.	980-200177	980-200177	Tail Light Mount - Curb Side
16 a.	900-2908-76	900-2908-76	LED Tail Light
b.	900-2908-74	900-2908-74	Adapter Wire for LED Tail Light (Not Shown)
17.	900-2908-75	900-2908-75	Rubber Grommet for LED Tail Light
18.	980-0508-72	980-0508-72	Heavy Duty Tail Light Cover
19.	981-1005-30	981-1005-30	Wooden Push Paddle
20.	980-0122-55	980-0122-55	Wooden Push Paddle Mount
21.	980-300181	980-300181	License Plate and Light Mount
22.	900-2900-07	900-2900-07	License Plate Light
23.	911-300076	911-300076	Hydraulic Control Arm - 19 1/4"
24.	980-100141	980-100141	Feedwheel Control Valve Linkage
25.	955-300104	955-300104	Bottom Feedwheel Bearing Backer Plate
26 a.	900-1909-80	900-1909-80	Feedwheel Bearing (Grip-Tight Style) (Start 8/04)
b.	900-4912-37	900-4912-37	Top Feedwheel Bearing Bolt (1/2"-13NC x 1" SHCS)
c.	900-4909-23	900-4909-23	Bottom Feedwheel Bearing Bolt (1/2"-13NC x 1 1/4" SHCS)
d.	900-1900-66	900-1900-66	Feedwheel Bearing (Pre 8/04)
e.	900-4900-13	900-4900-13	Feedwheel Bearing Bolt (Pre 8/04)
27 a.	981-300199	N/A	Bottom Torque Arm Stop (Start 3/07)
b.	911-1002-39	N/A	Bottom Torque Arm Stop (Pre 3/07)
c.	N/A	981-300199	Bottom Torque Arm Stop (Start 2/05)
d.	N/A	911-1002-39	Bottom Torque Arm Stop (10/02 - 2/05)
e.	N/A	981-1006-71	Bottom Torque Arm Stop (S/N 1013 - 1017)
f.	937-300316	937-300316	Torque Arm Cushion Mount (Start 4/06)
g.	955-1014-01	955-1014-01	Torque Arm Stop Block (Pre 4/06)
28.	937-900009	937-900009	Torque Arm Cushion (Start 4/06)
29 a.	900-7901-23	900-7901-23	Rubber Coupler Guard (Start 5/05)
b.	900-7900-38	900-7900-38	Rubber Coupler Guard (Pre 5/05)
c.	980-0508-57	980-0508-57	Coupler Guard Mount (Not Shown)

NOTE: The Model 1590 hydraulic feedwheel motors may be on the road side or the curb side of the machine, depending on the machine S/N. Grip-Tight style feedwheel bearing is on the hydraulic motor side.

Bandit

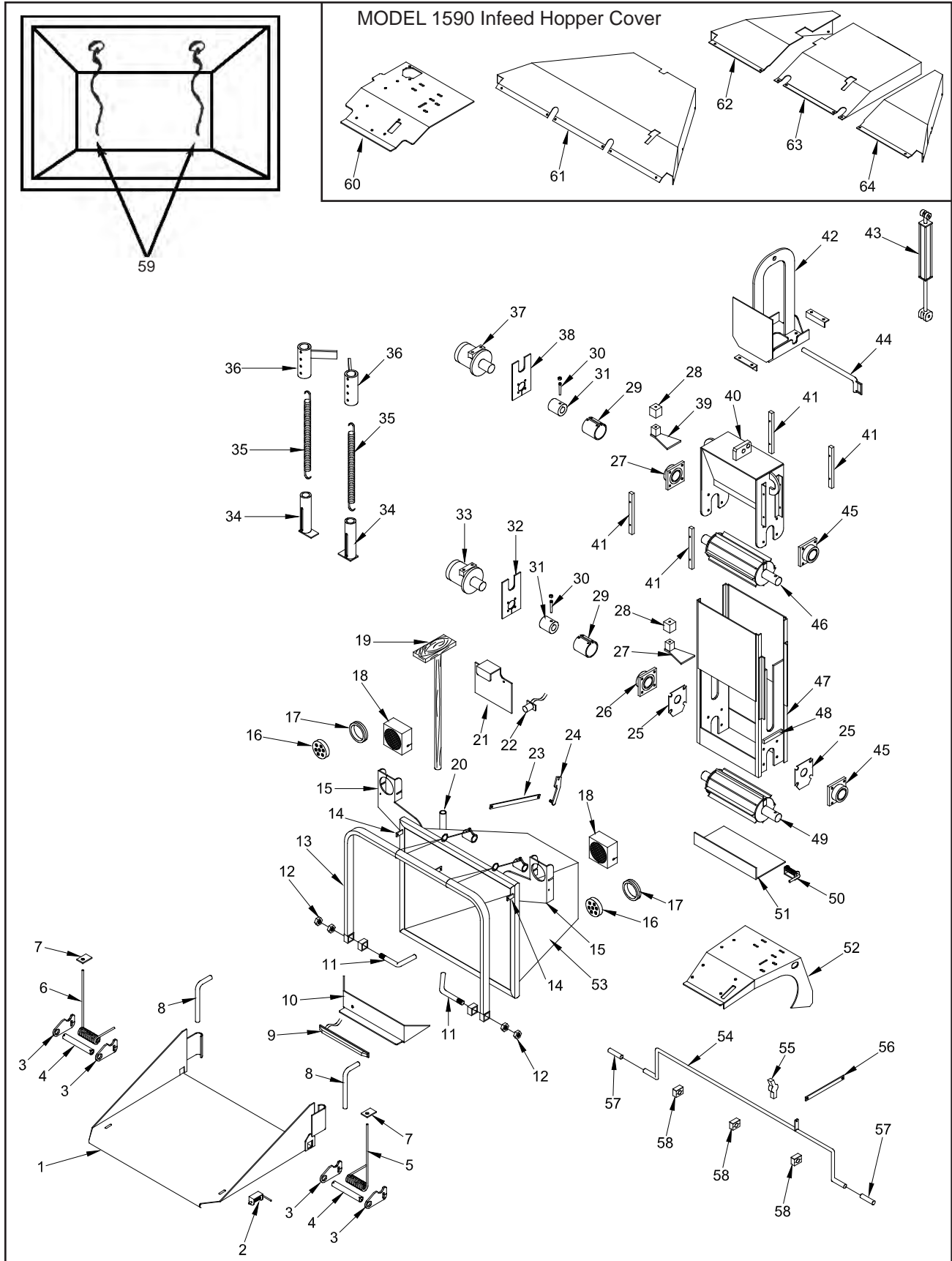

NOTE: Parts may not be exactly as shown.

Bandit

MODELS 1290XP/1590

INFEED HOPPER COMPONENTS

LOCATION	MODEL 1290XP PART NUMBER	MODEL 1590 PART NUMBER	DESCRIPTION
30 a.	900-4909-54	900-4909-54	Taper Pin With Nut (Start 5/05)
b.	900-4905-55	900-4905-55	Taper Pin (Pre 5/05)
31 a.	981-300140	981-300140	Coupler With Motor Nut and Taper Pin With Nut (Start 5/05)
b.	981-1006-45	981-1006-45	Coupler With Motor Nut and Taper Pin (Pre 5/05)
32 a.	981-100050	981-100050	Bottom Torque Arm With Coupler Guard Mount (Start 4/06)
b.	981-300196	981-300196	Bottom Feedwheel Torque Arm (Start 4/06)
c.	981-1006-43	981-1006-43	Bottom Feedwheel Torque Arm (Pre 4/06)
33 a.	900-3908-68	N/A	Bottom Feedwheel Hydraulic Motor
b.	N/A	900-3908-68	Bottom Feedwheel Hydraulic Motor (Start 12/05)
c.	N/A	900-3908-67	Bottom Feedwheel Hydraulic Motor (Pre 12/05)
34 a.	981-300031	981-300031	Bottom Mount for Easy Climb System
b.	900-4905-79	900-4905-79	Clevis Pin (Not Shown)
c.	900-4905-80	900-4905-80	Cotter Pin for Clevis Pin (Not Shown)
d.	900-4900-36	900-4900-36	Flat Washer (Not Shown)
35 a.	900-4903-81	N/A	Yoke Spring (Start 3/07)
b.	900-4900-04	N/A	Yoke Spring (Pre 3/07)
c.	N/A	900-4903-81	Yoke Spring
36 a.	981-300030	981-300030	Top Mount for Easy Climb System
b.	900-4905-14	900-4905-14	Clevis Pin (Not Shown)
c.	900-4905-19	900-4905-19	Hair Pin for Clevis Pin (Not Shown)
37 a.	900-3908-67	N/A	Top Feedwheel Hydraulic Motor
b.	N/A	900-3908-67	Top Feedwheel Hydraulic Motor (Start 12/05)
c.	N/A	900-3908-68	Top Feedwheel Hydraulic Motor (Pre 12/05)
38 a.	981-100049	981-100049	Top Torque Arm With Coupler Guard Mount (Start 4/06)
b.	981-300197	981-300197	Top Feedwheel Torque Arm (Start 4/06)
c.	981-1006-44	N/A	Top Feedwheel Torque Arm (Pre 4/06)
d.	N/A	981-1006-44	Top Feedwheel Torque Arm (2/05 - 4/06)
e.	N/A	981-1006-43	Top Feedwheel Torque Arm (Pre 2/05)
39 a.	981-300199	981-300199	Top Torque Arm Stop
b.	937-300316	937-300316	Torque Arm Cushion Mount (Start 4/06)
c.	955-1014-01	955-1014-01	Torque Arm Stop Block (Pre 4/06)
40 a.	912-200003	912-200003	Top Yoke Assembly (Start 2/05)
b.	912-0500-02A	911-0500-27A	Top Yoke Assembly (8/04 - 2/05)
c.	912-0500-02	911-0500-27	Top Yoke Assembly (Pre 8/04)
41 a.	980-0138-10	980-0138-10	Yoke Phenolic Slide - 1" x 1"
b.	980-0111-08	980-0111-08	Yoke Phenolic Slide - 3/4" x 1"
42 a.	911-200011	N/A	Yoke Lift Assembly (Start 3/07)
b.	912-200015	N/A	Yoke Lift Assembly (Pre 3/07)
c.	N/A	955-0500-36	Yoke Lift Assembly (Start 6/07)
d.	N/A	911-200011	Yoke Lift Assembly (Pre 6/07)
e.	981-300138	981-300138	Top Yoke Plate Without Yoke Lift (Not Shown)
f.	955-1005-76	955-1005-76	Yoke Lift / Top Plate Angle Mount
g.	980-0132-68	980-0132-68	Decal Plate Only
43 a.	900-3928-15	N/A	Yoke Lift Cylinder - Welded (Start 3/07)
b.	900-3928-04	N/A	Yoke Lift Cylinder - Welded (Pre 3/07)
c.	N/A	900-3925-06	Yoke Lift Cylinder - Welded (Start 6/07)
d.	N/A	900-3928-15	Yoke Lift Cylinder - Welded (Pre 6/07)
e.	904-0007-14	904-0007-14	Pin For Welded Cylinder (Not Shown)
f.	900-4913-23	900-4913-23	Rubber Washer - Top Of Cylinder (Not Shown)

NOTE: The Model 1590 hydraulic feedwheel motors may be on the road side or the curb side of the machine, depending on the machine S/N. Grip-Tight style feedwheel bearing is on the hydraulic motor side.

Bandit

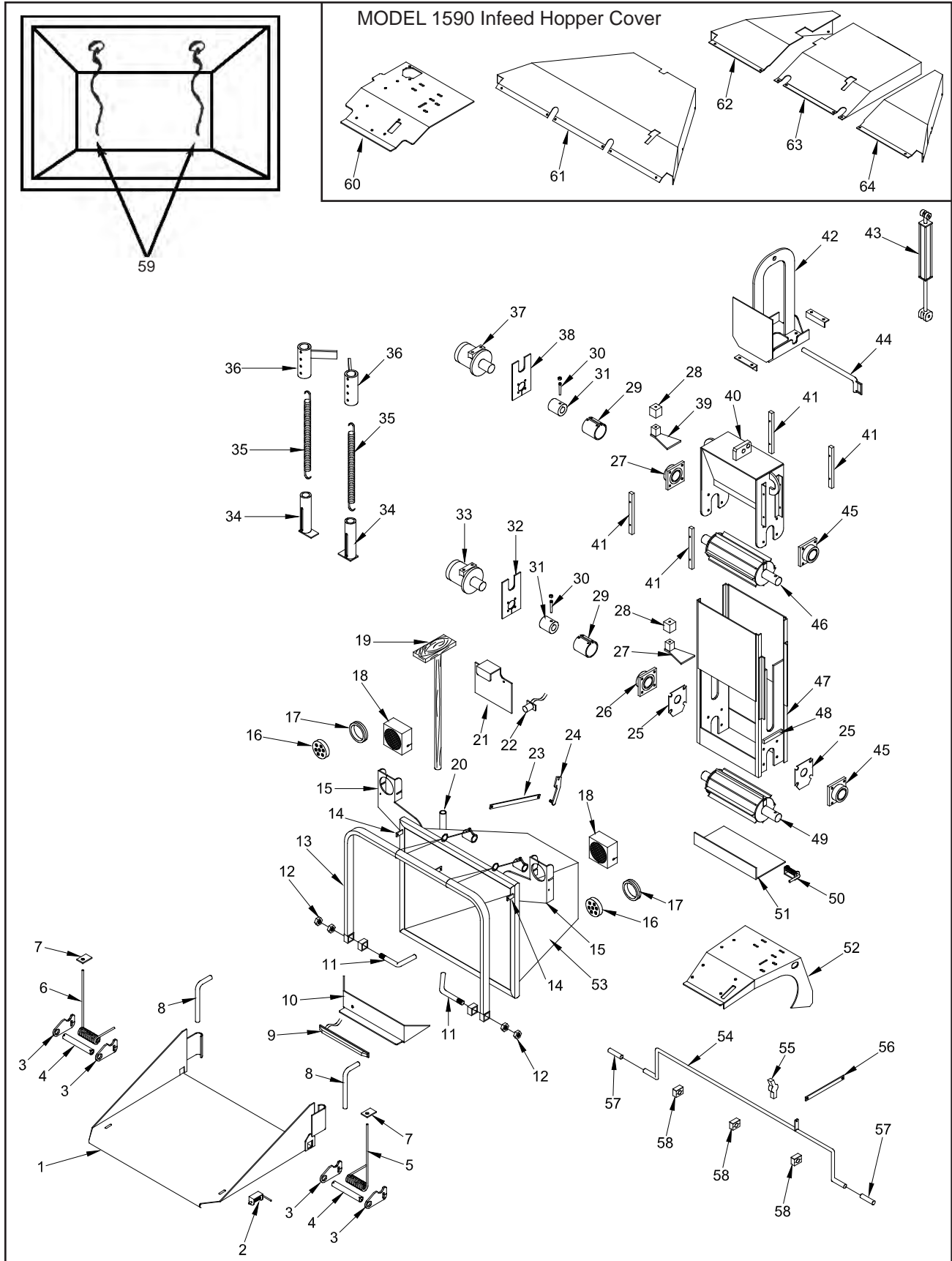

NOTE: Parts may not be exactly as shown.

Bandit

MODELS 1290XP/1590**INFEED HOPPER COMPONENTS**

LOCATION	MODEL 1290XP PART NUMBER	MODEL 1590 PART NUMBER	DESCRIPTION
44 a.	955-1005-91	955-1005-91	Yoke Lock Pin (Start 2/05)
b.	955-1005-80	955-1005-80	Yoke Lock Pin (Pre 2/05)
45 a.	900-1909-79	900-1909-79	Feedwheel Bearing (Set Screw Style) (Start 8/04)
b.	900-1909-81	900-1909-81	Feedwheel Bearing - Debris (Set Screw) (Start 8/04)
c.	900-4912-37	900-4912-37	Top Feedwheel Bearing Bolt (1/2"-13NC x 1" SHCS)
d.	900-4909-23	900-4909-23	Bottom Feedwheel Bearing Bolt (1/2"-13NC x 1 1/4" SHCS)
e.	900-1900-66	900-1900-66	Feedwheel Bearing (Pre 8/04)
f.	900-4900-13	900-4900-13	Feedwheel Bearing Bolt (Pre 8/04)
46 a.	912-0500-10	N/A	Top Feedwheel Assembly
b.	N/A	912-0500-10	Top Feedwheel Assembly (Start 12/05)
c.	N/A	955-0500-47	Top Feedwheel Assembly (Pre 12/05)
d.	955-1001-52	955-1001-52	Top Feedwheel Tooth
e.	955-0500-46	955-0500-46	Top Feedwheel Shaft & Coupler Assembly
47 a.	912-200032	N/A	Feedwheel Slide Box Assembly (Start 3/07)
b.	912-200005	N/A	Feedwheel Slide Box Assembly (2/05 - 3/07)
c.	N/A	911-2000-48	Feedwheel Slide Box Assembly (Start 8/07)
d.	N/A	911-2000-53	Feedwheel Slide Box Assembly (6/07 - 8/07)
e.	N/A	911-200006	Feedwheel Slide Box Assembly (2/05 - 6/07)
f.	912-0500-05A	911-0500-21A	Feedwheel Slide Box Assembly (8/04 - 2/05)
g.	912-0500-05	911-0500-21	Feedwheel Slide Box Assembly (Pre 8/04)
48.	955-1002-45	955-1002-45	Yoke Stop Block
49 a.	912-0500-09	N/A	Bottom Feedwheel Assembly
b.	N/A	912-0500-09	Bottom Feedwheel Assembly (Start 12/05)
c.	N/A	914-0502-52	Bottom Feedwheel Assembly (Pre 12/05)
d.	955-1001-52	955-1001-52	Bottom Feedwheel Tooth
e.	955-0500-46	955-0500-46	Bottom Feedwheel Shaft & Coupler Assembly
50.	900-4901-83	900-4901-83	Trap Door Spring Lock
51 a.	911-0500-30	911-0500-30	Trap Door Assembly
b.	981-1000-60	981-1000-60	Hinge For Trap Door
52.	912-200012	911-200008	Winch and Valve Mount
53 a.	912-0500-03	N/A	Infeed Hopper Assembly (Start 3/07)
b.	912-200007	N/A	Infeed Hopper Assembly (Pre 3/07)
c.	N/A	955-0500-09	Infeed Hopper Assembly (Start 8/07)
d.	N/A	911-200007	Infeed Hopper Assembly (Pre 8/07)
54 a.	904-0006-91	904-0006-91	Dual Yoke Lift Control Bar Kit
b.	912-300020	980-300065	Dual Yoke Lift Control Bar
55.	900-3930-96	900-3930-96	Short Valve Handle - Lift Cylinder Control Linkage
56.	980-300157	980-300157	Control Arm - Dual Yoke Lift - 12 1/2"
57.	900-7900-96	900-7900-96	Rubber Cap - Dual Yoke Lift Control Bar
58.	900-3914-02	900-3914-02	Clamp - Lift Control Bar
59.	980-0508-64	980-0508-64	Last Chance Cable Assembly
60.	N/A	911-300025	Winch Mount
61.	N/A	911-1001-72	Infeed Hopper Hydraulic Cover (Specify S/N)
62.	N/A	911-1002-49	Infeed Hopper Hydraulic Cover - Road Side With Winch Option
63.	N/A	911-1002-48	Infeed Hopper Hydraulic Cover Winch Tunnel Mount
64.	N/A	911-1002-50	Infeed Hopper Hydraulic Cover - Curb Side With Winch Option
65.	980-0100-70	980-0100-70	Bottom Feedwheel Scrapper Bar (Not Shown)

NOTE: The Model 1590 hydraulic feedwheel motors may be on the road side or the curb side of the machine, depending on the machine S/N. Grip-Tight style feedwheel bearing is on the hydraulic motor side.

Bandit

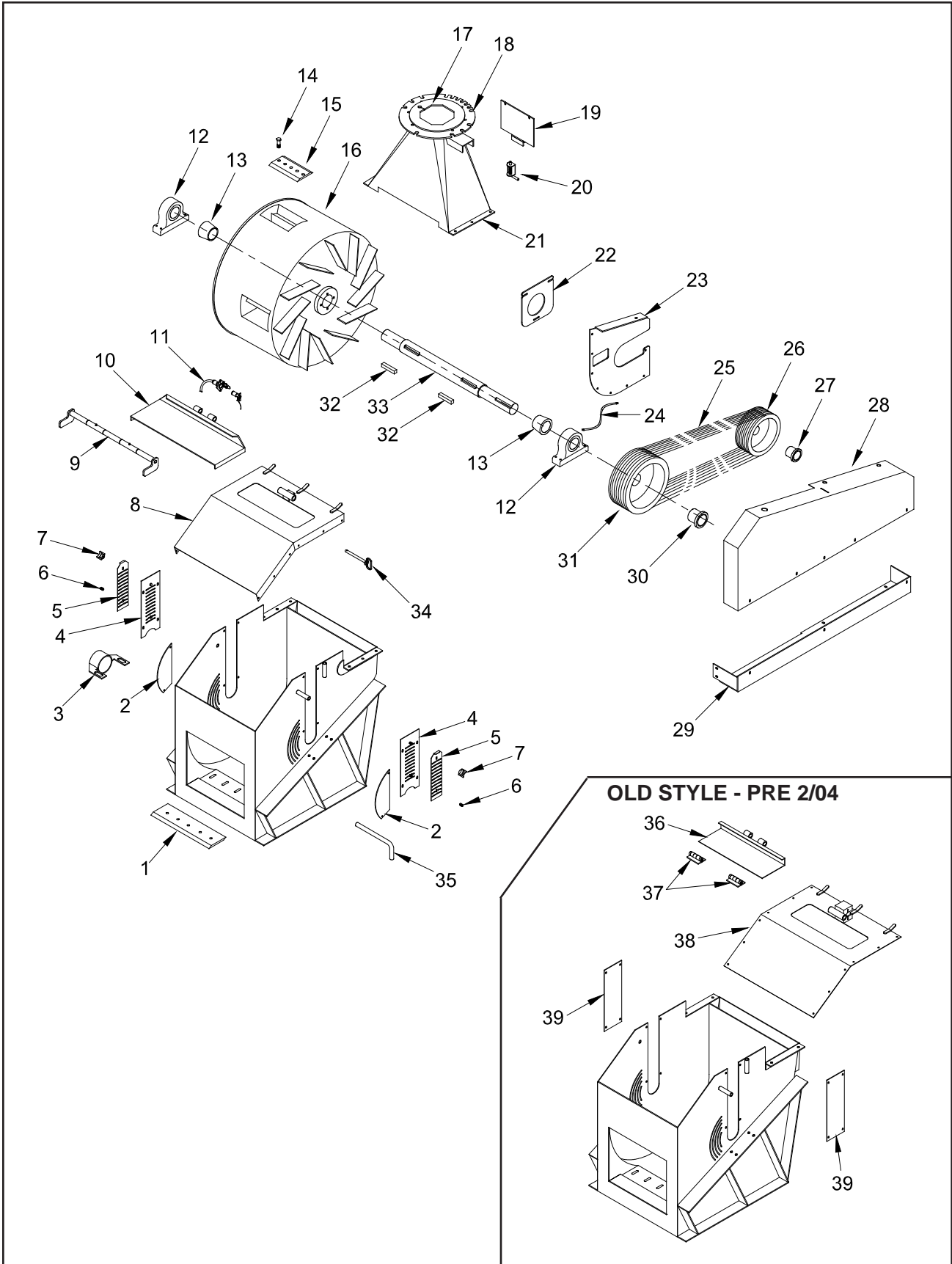

NOTE: Parts may not be exactly as shown.

Bandit

LOCATION	MODEL 1290XP PART NUMBER	MODEL 1590 PART NUMBER	DESCRIPTION
1.	See Page 87	See Page 87	Anvil
2.	911-1001-88	911-1001-88	Vent Cover
3.	911-0500-31	911-0500-31	Drum Shaft Bearing Cover
4.	937-1012-38	937-1012-38	Base Slot Cover
5 a.	937-300007	937-300007	Air Vent Cover - Steel
b.	937-300008	937-300008	Air Vent Cover - Aluminum
c.	937-100001	937-100001	Air Vent Cover Kit - Steel (Includes Two Pieces Of 5,6,7)
d.	937-100000	937-100000	Air Vent Cover Kit - Aluminum (Includes Two Pieces Of 5,6,7)
6.	900-4908-33	900-4908-33	Spring For Vent Cover
7.	900-4908-29	900-4908-29	Plastic Knob For Vent Cover
8.	912-300023	911-300019	Base Top
9 a.	937-200086	937-200086	Hood Door Hinge Kit (Includes 9b - 9f) (Start 8/06)
b.	937-300304	937-300304	Pin For Hood Door Hinge
c.	937-300301	937-300301	Side Mount For Hood Door Hinge
d.	937-300302	937-300302	Tube For Hood Door Hinge
e.	937-300307	937-300307	Tube With Grease Zerk Hole For Hood Door Hinge
f.	900-4911-84	900-4911-84	Grease Zerk For Hood Door Hinge
10.	912-300022	937-300032	Hood Door
11 a.	937-200133	937-200133	Engine Disable Plug Kit (Includes Hood Pin & Mounts)
b.	900-2904-13	900-2904-13	6-Prong Female Plug Only
c.	980-100083	980-100083	6-Prong Male Plug With Wire Loop & Crimp Sleeves
12 a.	900-1905-97	900-1905-97	Chipper Drum Bearing
b.	900-4910-40	900-4910-40	Chipper Drum Bearing Bolt - Road Side Only (Not Shown)
c.	900-4910-34	900-4910-34	Chipper Drum Bearing Bolt - Curb Side Only (Not Shown)
d.	900-4903-21	900-4903-21	Chipper Drum Bearing Washer - Mill Carb (Not Shown)
e.	900-4910-19	900-4910-19	Chipper Drum Bearing Jam Nut-Road Side Only (Not Shown)
f.	900-4901-23	900-4901-23	Chipper Drum Bearing Nut (Not Shown)
13.	900-1906-26	900-1906-26	Drum Head Bushing
14.	See Page 86	See Page 86	Chipper Knife Bolt
15.	See Page 86	See Page 86	Chipper Knife
16.	912-0500-01	911-0500-37	Chipper Drum Head Assembly With Shaft
17.	937-1005-63	937-1005-63	Hood Flange
18 a.	980-0128-24	980-0128-24	Bottom Swivel Ring For Manual Swivel Discharge
b.	980-0128-23	980-0128-23	Bottom Swivel Ring For Hand Crank Swivel Discharge
c.	980-0122-18	980-0122-18	Bottom Swivel Ring For Hydraulic Swivel Discharge
19.	937-0501-31	937-0501-31	Optional Clean Out Door Assembly
20 a.	900-4908-27	900-4908-27	Discharge Spring Lock
b.	900-7900-96	900-7900-96	Rubber Cap (Not Shown)
21.	912-200013	911-0500-23	Transition Assembly
22.	912-300065	912-300065	Adjustable Cover - Engine PTO Sheave
23.	912-300039	912-300039	Removable PTO Cover - Beltshield Back
24.	900-3921-02	900-3921-02	Chipper Bearing Grease Line

**NOTE: Nuts, bolts, washers, and all other components can be ordered by physical description.
 ** Components vary with engine options order by physical description or machine S/N.**

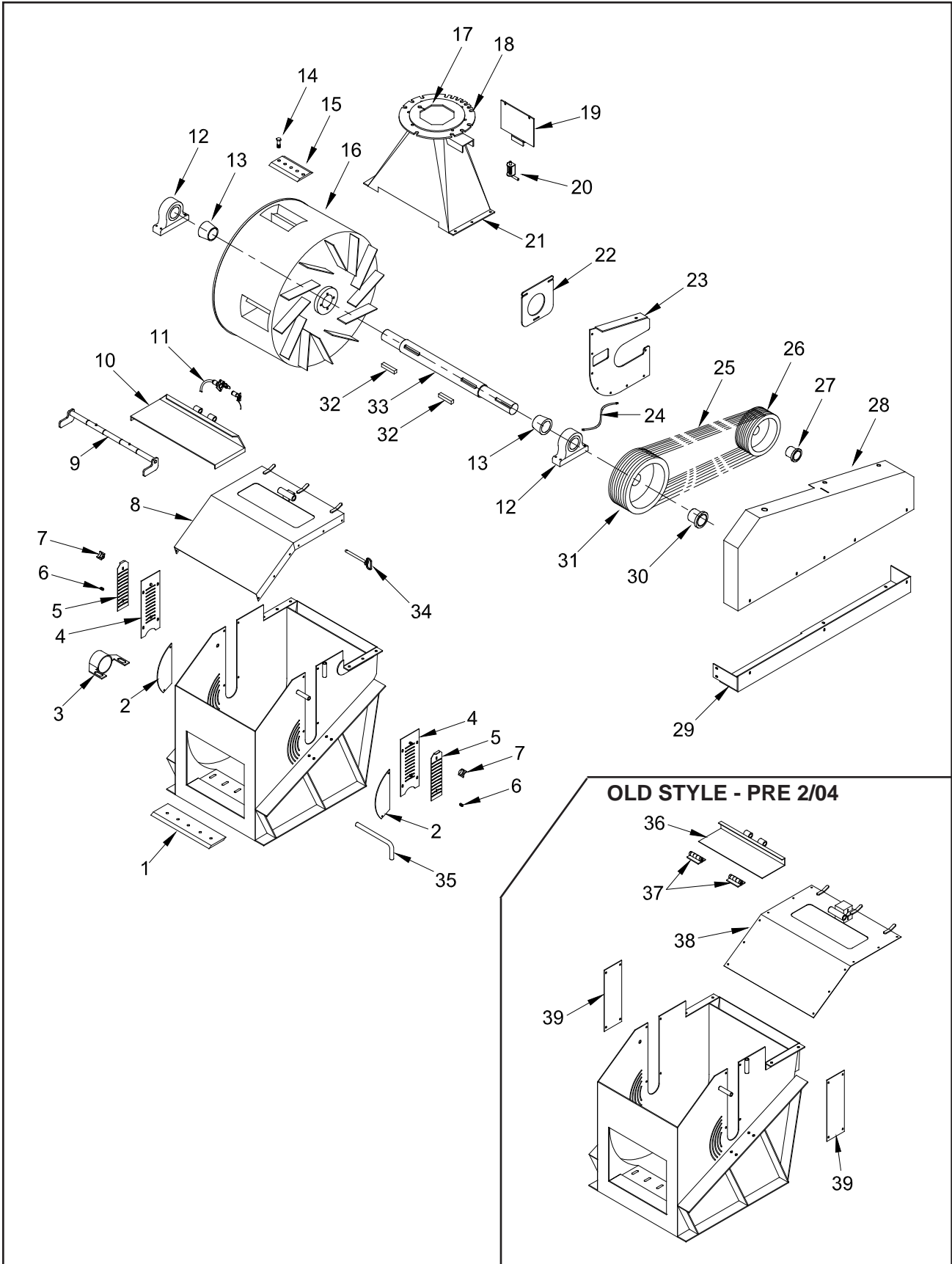

NOTE: Parts may not be exactly as shown.

Bandit

LOCATION	MODEL 1290XP PART NUMBER	MODEL 1590 PART NUMBER	DESCRIPTION
25.	**	**	Chipper Belts
26.	**	**	Engine Sheave
27.	**	**	Engine Sheave Bushing
28.	911-0500-25	911-0500-25	Beltshield
29.	912-200016	912-200016	Beltshield Bottom
30.	**	**	Chipper Sheave
31.	**	**	Chipper Sheave Bushing
32.	937-1004-19	937-1004-19	Key For Drum Head Shaft
33.	912-1000-94	911-1002-19	Drum Head Shaft
34 a.	911-100000	911-100000	Hood Pin With Attaching Chain
b.	900-4902-20	900-4902-20	Padlock For Hood Pin (Not Shown)
c.	P812	P812	Key For Padlock (Not Shown)
35 a.	955-1003-94	955-1003-94	Drum Lock Pin
b.	900-7900-96	900-7900-96	Rubber Cap (Not Shown)
36.	N/A	937-1009-24	Hood Door (Pre 2/04)
37.	937-1002-82	937-1002-82	Hood Door Hinge (Pre 8/06)
38.	N/A	911-1000-97	Base Top (Pre 2/04)
39.	911-1001-98	911-1001-98	Base Strap (Pre 2/04)

**NOTE: Nuts, bolts, washers, and all other components can be ordered by physical description.
 ** Components vary with engine options order by physical description or machine S/N.**

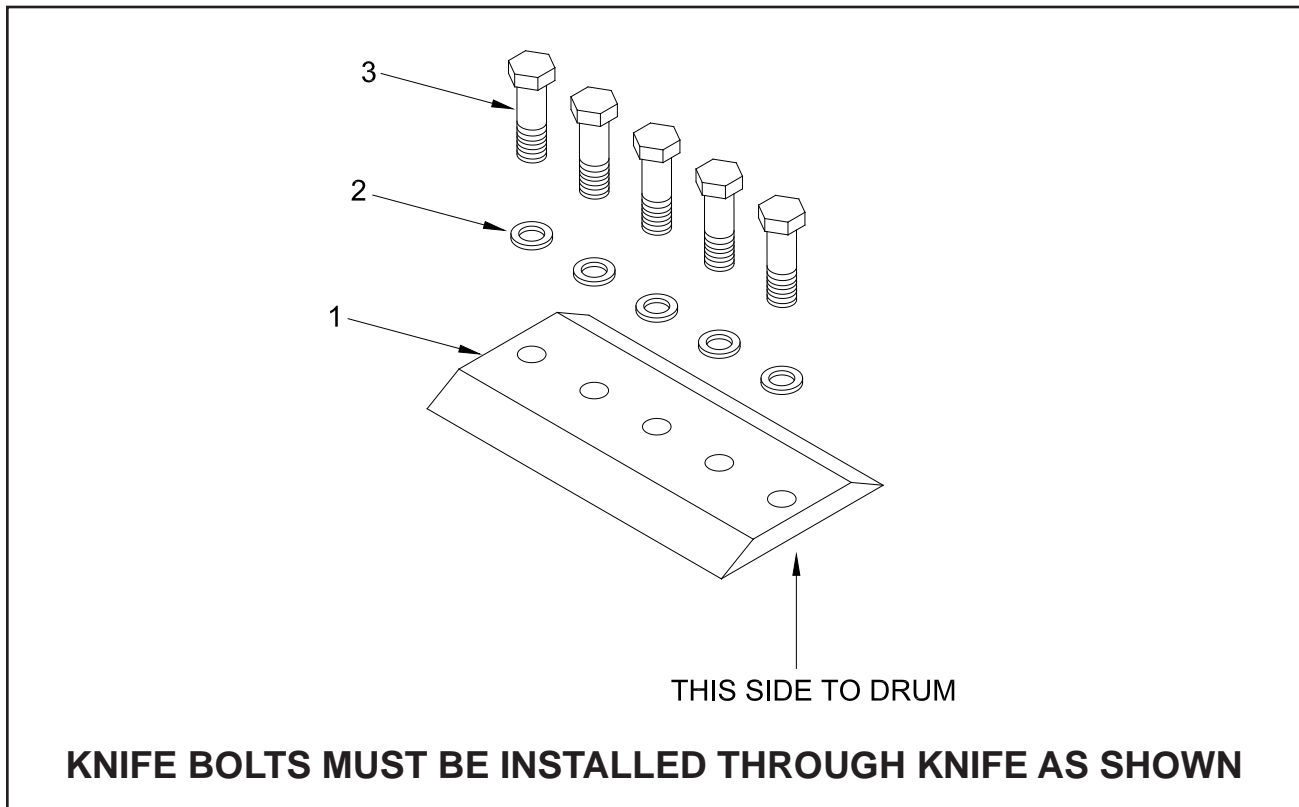

Part Numbers For Models 1290XP/1590 Knives

LOCATION	PART NUMBER	DESCRIPTION
1.	900-9902-27	5/8" x 5 1/2" x 10" Chipper Knife
2.	900-4901-32	5/8" Mill Carb Washer
3.	900-4900-20	5/8"-11NC x 2" Knife Bolt

NOTE: Torque Knife Bolts to 180 ft.-lbs. (245 Nm)

Part Numbers For Miscellaneous Knife Parts

LOCATION	PART NUMBER	DESCRIPTION
4.	900-9901-68	Knife Saver Kit (Not Shown)
5.	900-9901-65	File For Knife Saver Kit Only (Not Shown)
6.	900-9901-63	Replacement Blades For Knife Saver (Not Shown)

NOTE: Parts may not be exactly as shown.

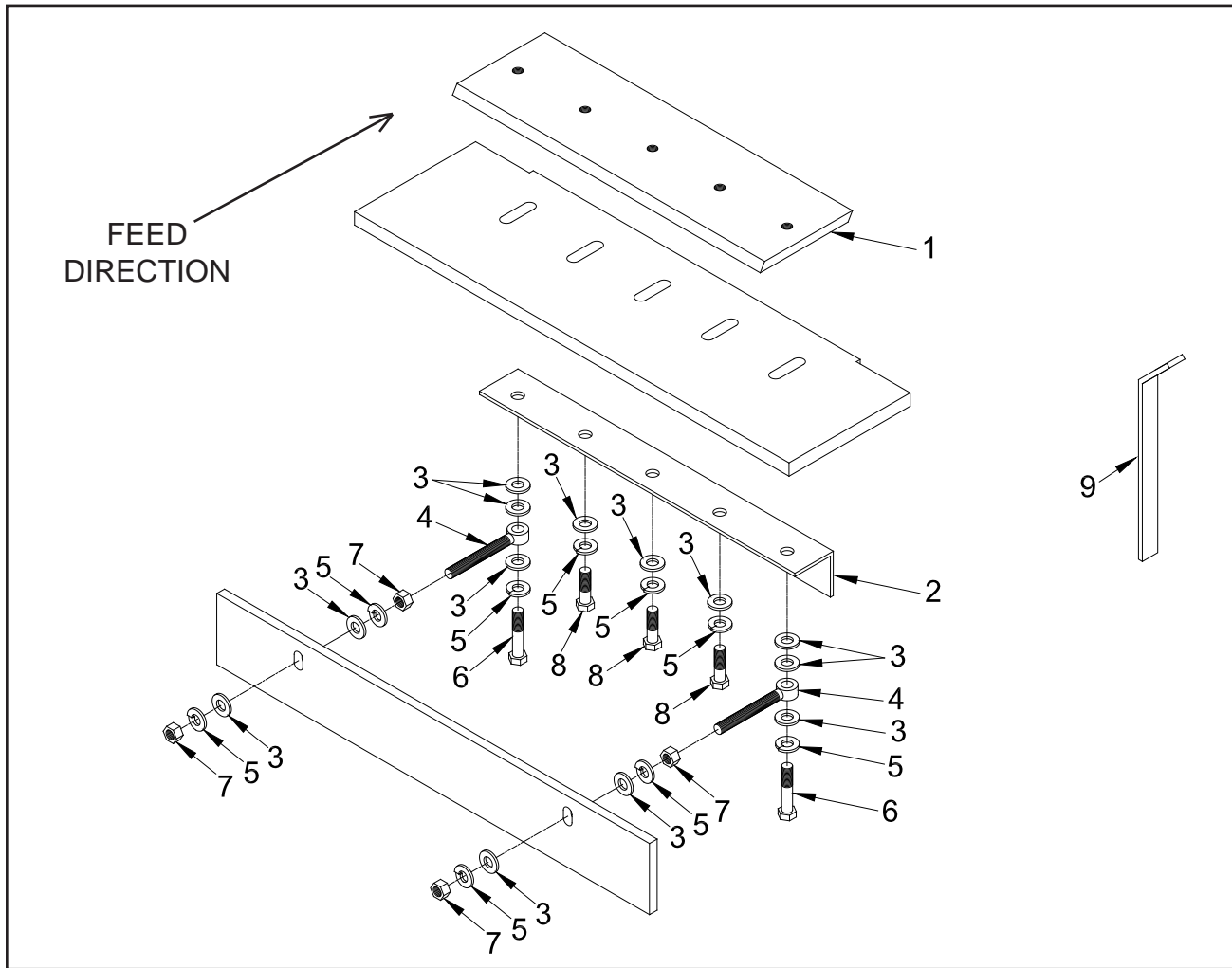

LOCATION	PART NUMBER	DESCRIPTION
1 a.	937-1001-72	Anvil Only
1 b.	937-1004-37	"AR" Anvil Only
2.	911-1001-74	Anvil Clamp Plate
3.	900-4909-18	1/2" Mill Carb Washer
4 a.	900-4907-91	Anvil Eye Bolt - 1/2"-13NC x 4 1/2" (Current)
4 b.	900-4902-73	Anvil Eye Bolt - 1/2"-13NC x 5 1/2" (Prior)
5.	900-4902-11	1/2" Lock Washer
6.	900-4903-17	1/2"-13NC x 2 1/2" Hex Head Bolt
7.	900-4900-45	1/2"-13NC Hex Nut
8.	900-4900-74	1/2"-13NC x 2" Hex Head Bolt
9.	981-1006-25	Anvil Gauge
10.	904-0003-90	Anvil Hardware Kit Only (Includes 3 Through 8)
11.	937-0501-64	Anvil and Hardware Kit (Includes 1a & 3 Through 8)

NOTE: Torque Anvil Bolts to 75 ft.-lbs. (102 Nm)

NOTE: Parts may not be exactly as shown.

STANDARD DISCHARGE

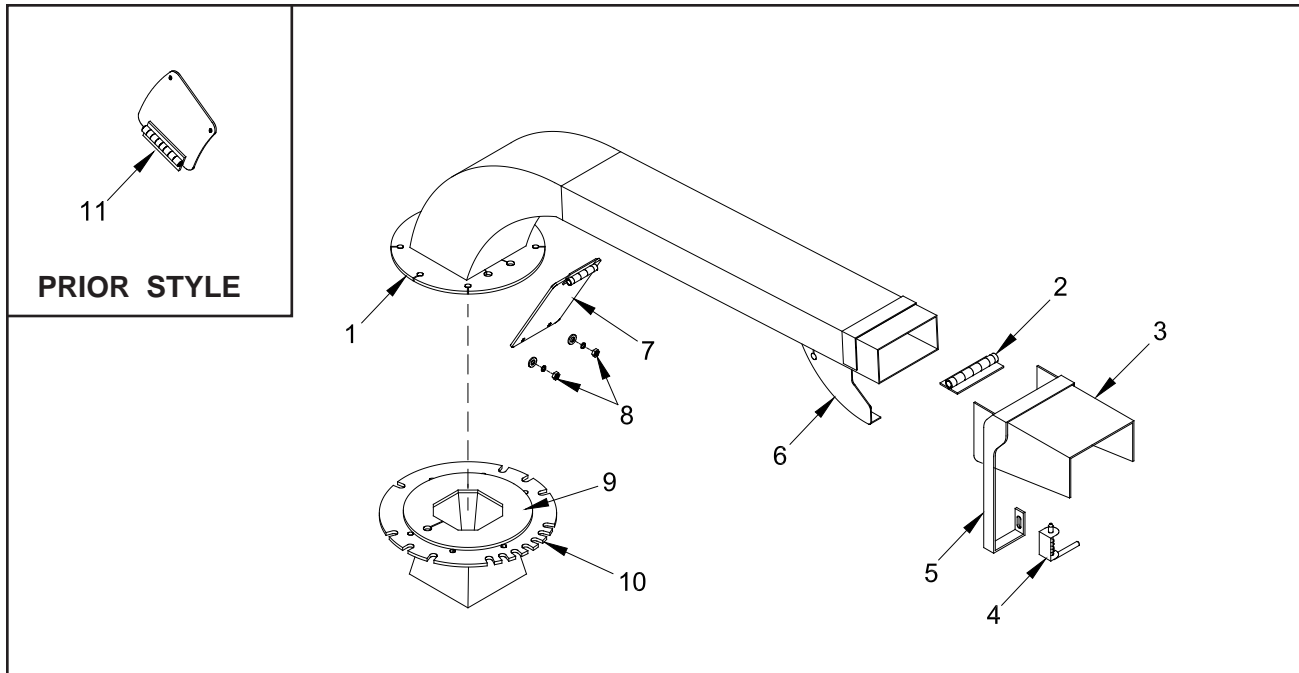

LOCATION	PART NUMBER	DESCRIPTION
1.	980-0127-33	Discharge Bottom Swivel Ring
2.	981-1001-63	Discharge Flipper Hinge
3 a.	937-1009-10	12" Discharge Flipper Assembly
b.	937-0502-24	12" Enclosed Discharge Flipper Assembly
c.	937-0501-63	12" Enclosed Discharge Flipper Assembly For Hydraulic Flipper
4.	900-4901-83	Discharge Flipper Adjusting Spring
5.	937-1009-14	Adjusting Spring Mount
6 a.	980-0510-23	Adjusting Spring Lock Plate Assembly For Standard Flipper
b.	980-0510-24	Adjusting Spring Lock Plate Assembly For Enclosed Flipper
7.	980-300616	Optional Clean Out Door (Optional On All Discharges)
8 a.	900-4910-73	5/16"-18NC Hex Nut
b.	900-4906-47	5/16" Lock Washer
c.	900-4906-48	5/16" Washer
9.	937-1005-63	Hood Flange
10.	980-300424	Bottom Swivel Ring
11.	980-0509-94	Optional Clean Out Door Assembly (Pre 9/06)
12 a.	900-4911-04	Discharge Transport Bolt - 5/8"-11NC x 1 1/2" (Not Shown)
b.	900-4903-25	Discharge Transport Nut - 5/8"-11NC (Not Shown)

DISCHARGE ASSEMBLIES

LOCATION	PART NUMBER	DESCRIPTION
1.	937-0500-14	Standard Discharge Assembly
2.	937-0500-19	Hand Crank And Adjustable Height Discharge Assembly
3.	937-0500-16	Hand Crank Discharge Assembly
4.	937-0500-18	Hydraulic Swivel And Adjustable Height Discharge Assembly
5.	937-0500-15	Hydraulic Swivel Discharge Assembly
6.	937-0500-17	Adjustable Height Discharge Assembly

NOTE: Parts may not be exactly as shown.

HAND CRANK ADJ. HEIGHT DISCHARGE

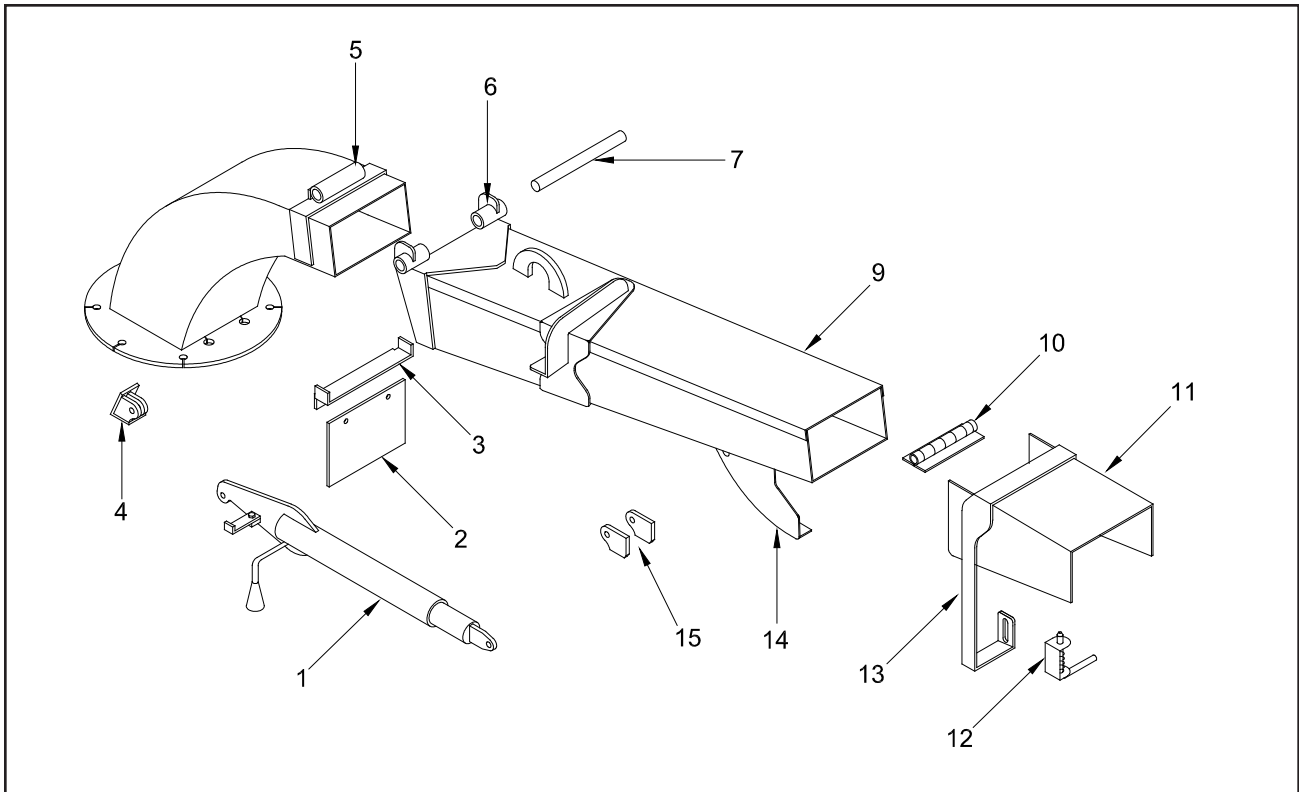

LOCATION	PART NUMBER	DESCRIPTION
1 a.	980-0510-86	Hand Crank For Adj. Height Discharge - Mounted On The Curb Side
b.	912-200035	Hand Crank For Adj. Height Discharge - Mounted On The Road Side
c.	980-0508-51	Hand Crank For Adj. Height Discharge - Mounted Underneath
2.	980-0126-12	Rubber Discharge Guard
3.	937-300318	Rubber Discharge Guard Mount
4.	980-300032	Hand Crank Adj. Height Mount Brackets
5.	980-300210	Hand Crank Adj. Height Hinge Large Hinge Tube
6.	980-300211	Hand Crank Adj. Height Small Hinge Tube
7.	980-300209	Hand Crank Adj. Height Hinge Pin
8.	937-200130	Hand Crank Adj. Height Hinge Assembly (Includes #'s 6 - 8)
9.	937-0501-65	Straight Section Hand Crank Adj. Height Discharge
10.	981-1001-63	Discharge Flipper Hinge
11 a.	937-1009-10	12" Discharge Flipper Assembly
b.	937-0502-24	12" Enclosed Discharge Flipper Assembly
c.	937-0501-63	12" Enclosed Discharge Flipper Assembly For Hydraulic Flipper
12.	900-4901-83	Discharge Flipper Adjusting Spring
13.	937-1009-14	Adjusting Spring Mount
14 a.	980-0510-23	Adjusting Spring Lock Plate For Standard Flipper
b.	980-0510-24	Adjusting Spring Lock Plate For Enclosed Flipper
15.	980-300032	Hand Crank Adj. Height Mount Brackets
16 a.	900-4911-04	Discharge Transport Bolt - 5/8"-11NC x 1 1/2" (Not Shown)
b.	900-4903-25	Discharge Transport Nut - 5/8"-11NC (Not Shown)

NOTE: Parts may not be exactly as shown.

Bandit

HYDRAULIC SWIVEL DISCHARGE

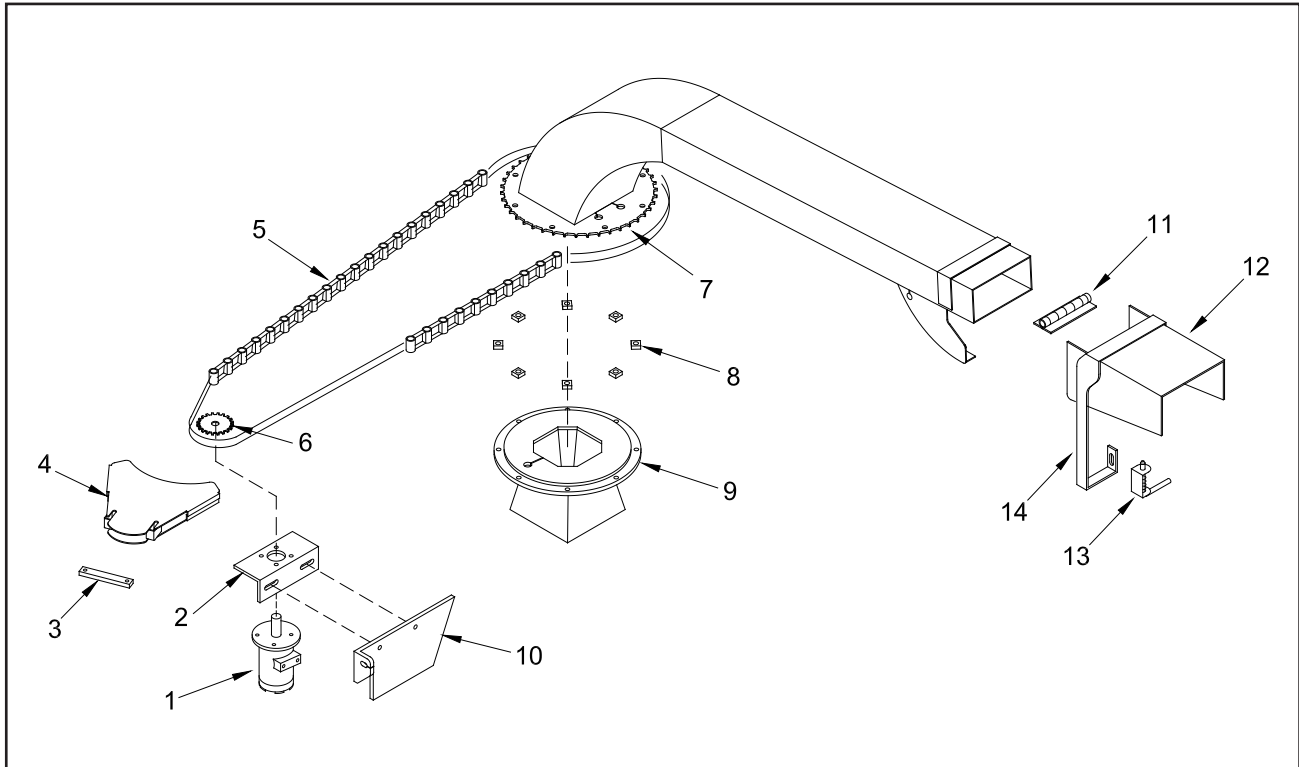

LOCATION	PART NUMBER	DESCRIPTION
1 a.	900-3902-14	Discharge Swivel Hydraulic Motor - Pipe Fitting
b.	900-3921-57	Discharge Swivel Hydraulic Motor - SAE O-ring
2.	980-0110-66	Hydraulic Swivel Mount
3.	937-1005-35	Chain Guard Mount
4.	937-200061	Hydraulic Swivel Chain Guard
5 a.	900-1901-20	#50 Roller Chain
b.	900-1901-18	Half Link- Chain (Not Shown)
c.	900-1901-19	Master Link - Chain (Not Shown)
6.	900-1901-21	Sprocket For Hydraulic Motor
7.	980-0110-63	Sprocket For Discharge (Weld On)
8.	900-4905-00	Spacer Washer
9.	980-0122-18	Bottom Swivel Ring
10.	937-1004-30	Hydraulic Swivel Motor Mount
11.	981-1001-63	Discharge Flipper Hinge
12 a.	937-1009-10	12" Discharge Flipper Assembly
b.	937-0502-24	12" Enclosed Discharge Flipper Assembly
c.	937-0501-63	12" Enclosed Discharge Flipper Assembly For Hydraulic Flipper
13.	900-4901-83	Discharge Flipper Adjusting Spring
14.	937-1009-14	Adjusting Spring Mount
15 a.	900-4911-04	Discharge Transport Bolt - 5/8"-11NC x 1 1/2" (Not Shown)
b.	900-4903-25	Discharge Transport Nut - 5/8"-11NC (Not Shown)

NOTE: Parts may not be exactly as shown.

Bandit

DISCHARGE WITH HYDRAULIC FLIPPER

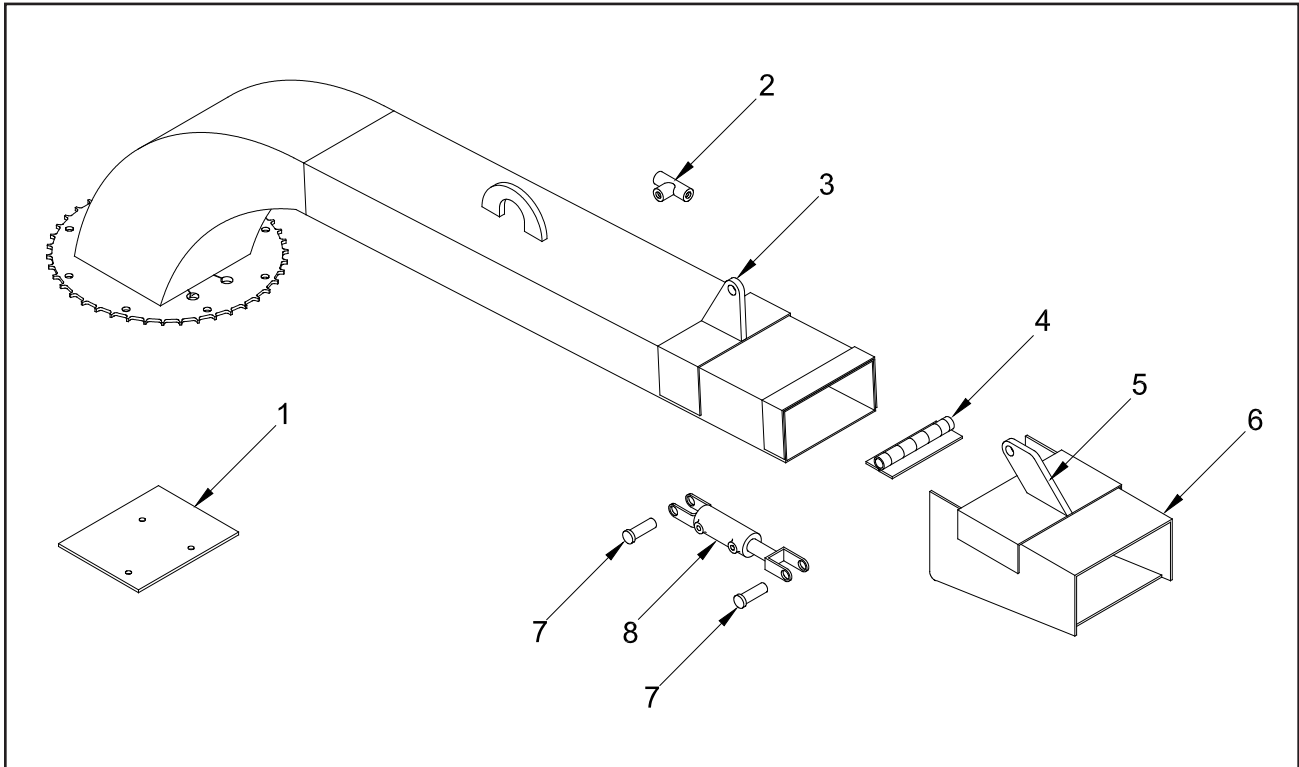

LOCATION	PART NUMBER	DESCRIPTION
1.	937-1003-30	Hydraulic Flipper Control Valve Mount Plate
2.	900-3925-18	Check Valve
3.	960-0006-42	Straight Section Cylinder Lug
4.	981-1001-63	Hydraulic Flipper Hinge
5.	980-0126-48	Flipper Lug
6.	937-0501-63	12" Hydraulic Flipper Assembly (Enclosed)
7.	900-3930-71	Cylinder Lug Pin - 3/4" Dia. x 2 1/2" & Cotter Pin - 1/4" x 1 1/2"
8.	900-3928-16	Hydraulic Flipper Cylinder
9.	900-3916-62	Swivel Discharge & Discharge Flipper Control Valve (Not Shown)
10 a.	900-4911-04	Discharge Transport Bolt - 5/8"-11NC x 1 1/2" (Not Shown)
b.	900-4903-25	Discharge Transport Nut - 5/8"-11NC (Not Shown)

NOTE: Parts may not be exactly as shown.

Bandit

HAND CRANK SWIVEL DISCHARGE

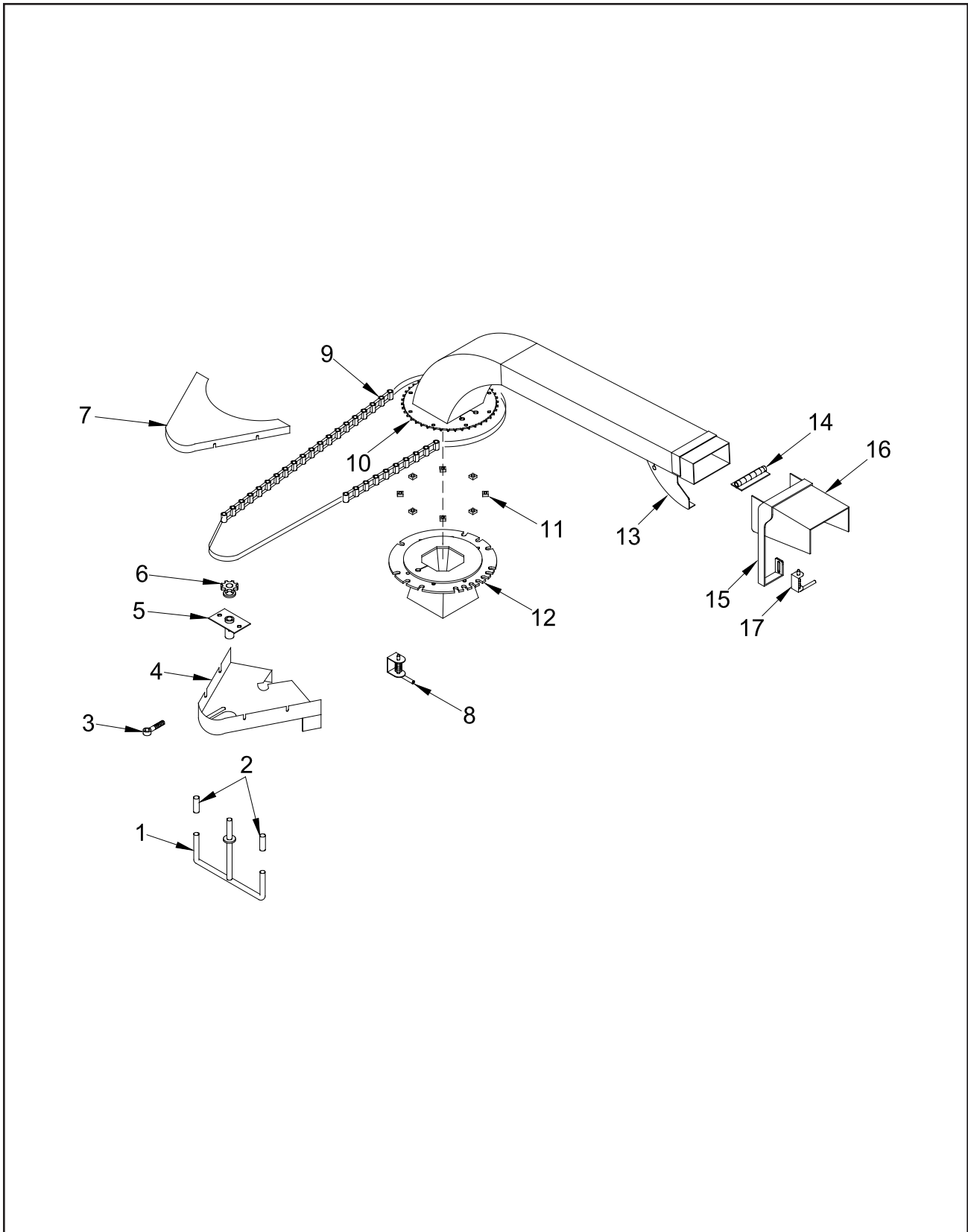

NOTE: Parts may not be exactly as shown.

LOCATION	PART NUMBER	DESCRIPTION
1.	937-200064	T-Handle Assembly
2.	900-7900-96	Rubber Cap
3.	900-4905-43	Eye Bolt Adjuster For Hand Crank Swivel Discharge
4 a.	912-300040	Bottom Chain Guard - Rounded Style
b.	937-300002	Bottom Chain Guard - Square Style
5.	980-200006	Chain Adjuster Assembly
6 a.	900-1905-59	T-Handle Sprocket
b.	980-0125-82	Key For Sprocket (Not Shown)
7 a.	980-200108	Steel Top Chain Guard - Rounded Style
b.	900-9904-64	Plastic Top Chain Guard - Rounded Style
c.	980-0138-22	Steel Top Chain Guard - Square Style
8 a.	900-4904-90	Spring Plunger
b.	900-7900-96	Rubber Cap
9 a.	980-0128-74	#50 Roller Chain
b.	900-1901-18	Half Link - Chain (Not Shown)
c.	900-1901-19	Master Link - Chain (Not Shown)
10.	980-0127-32	Sprocket For Hand Crank Swivel Discharge (Weld On)
11.	980-0137-35	Spacers Blocks
12.	980-0128-23	Bottom Swivel Ring
13 a.	980-0510-23	Adjusting Spring Lock Plate Assembly For Standard Flipper
b.	980-0510-24	Adjusting Spring Lock Plate Assembly For Enclosed Flipper
14.	981-1001-63	Discharge Flipper Hinge
15.	937-1009-14	Adjusting Spring Mount
16 a.	937-1009-10	12" Discharge Flipper Assembly
b.	937-0502-24	12" Enclosed Discharge Flipper Assembly
c.	937-0501-63	12" Enclosed Discharge Flipper Assembly For Hydraulic Flipper
17.	900-4901-83	Discharge Flipper Adjusting Spring
18 a.	900-4911-04	Discharge Transport Bolt - 5/8"-11NC x 1 1/2" (Not Shown)
b.	900-4903-25	Discharge Transport Nut - 5/8"-11NC (Not Shown)

TYPICAL MODELS 1290XP/1590
HYDRAULIC SCHEMATIC
(With No Options)

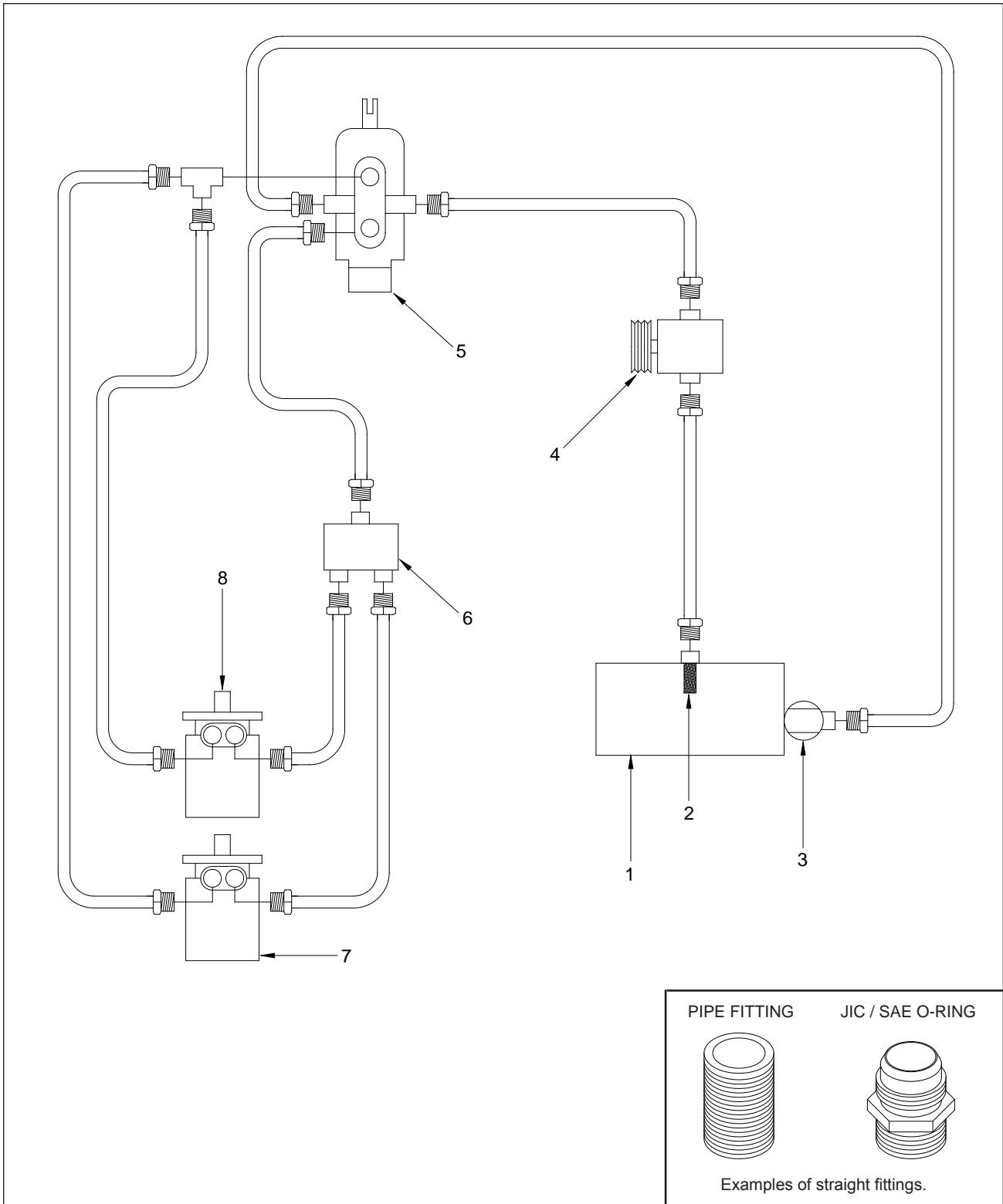

NOTE: Parts may not be exactly as shown.

Bandit

**TYPICAL MODELS 1290XP/1590
HYDRAULIC SCHEMATIC
(With No Options)**

LOCATION	PIPE FITTING	SAE O-RING	DESCRIPTION
1.	See Pages 112-113	See Pages 112-113	Hydraulic Tank
2.	900-3903-39	N/A	Hydraulic Tank Strainer
3 a.	900-3900-09	N/A	Filter Head
b.	900-3900-10	N/A	Filter
4.	**	**	Hydraulic Pump
5.	900-3909-89	900-3920-06A	Feedwheel Control Valve With Relief
6.	See Pages 100-101	See Pages 100-101	Flow Divider
7 a.	N/A	900-3908-68	Bottom Feedwheel Hydraulic Motor - Model 1290XP
b.	N/A	900-3908-68	Bottom Feedwheel Hydraulic Motor - Model 1590 (Start 12/05)
c.	N/A	900-3908-67	Bottom Feedwheel Hydraulic Motor - Model 1590 (Pre 12/05)
8 a.	N/A	900-3908-67	Top Feedwheel Hydraulic Motor - Model 1290XP
b.	N/A	900-3908-67	Top Feedwheel Hydraulic Motor - Model 1590 (Start 12/05)
c.	N/A	900-3908-68	Top Feedwheel Hydraulic Motor - Model 1590 (Pre 12/05)

NOTE: Make sure to order components according to fitting type, fittings may vary on all components.

**** Hydraulic components, fittings, hoses will vary depending on optional equipment. Order by physical description.**

**** Hydraulic pumps need to be ordered by physical description and serial number of machine.**

TYPICAL MODELS 1290XP/1590 HYDRAULIC SCHEMATIC (With Options)

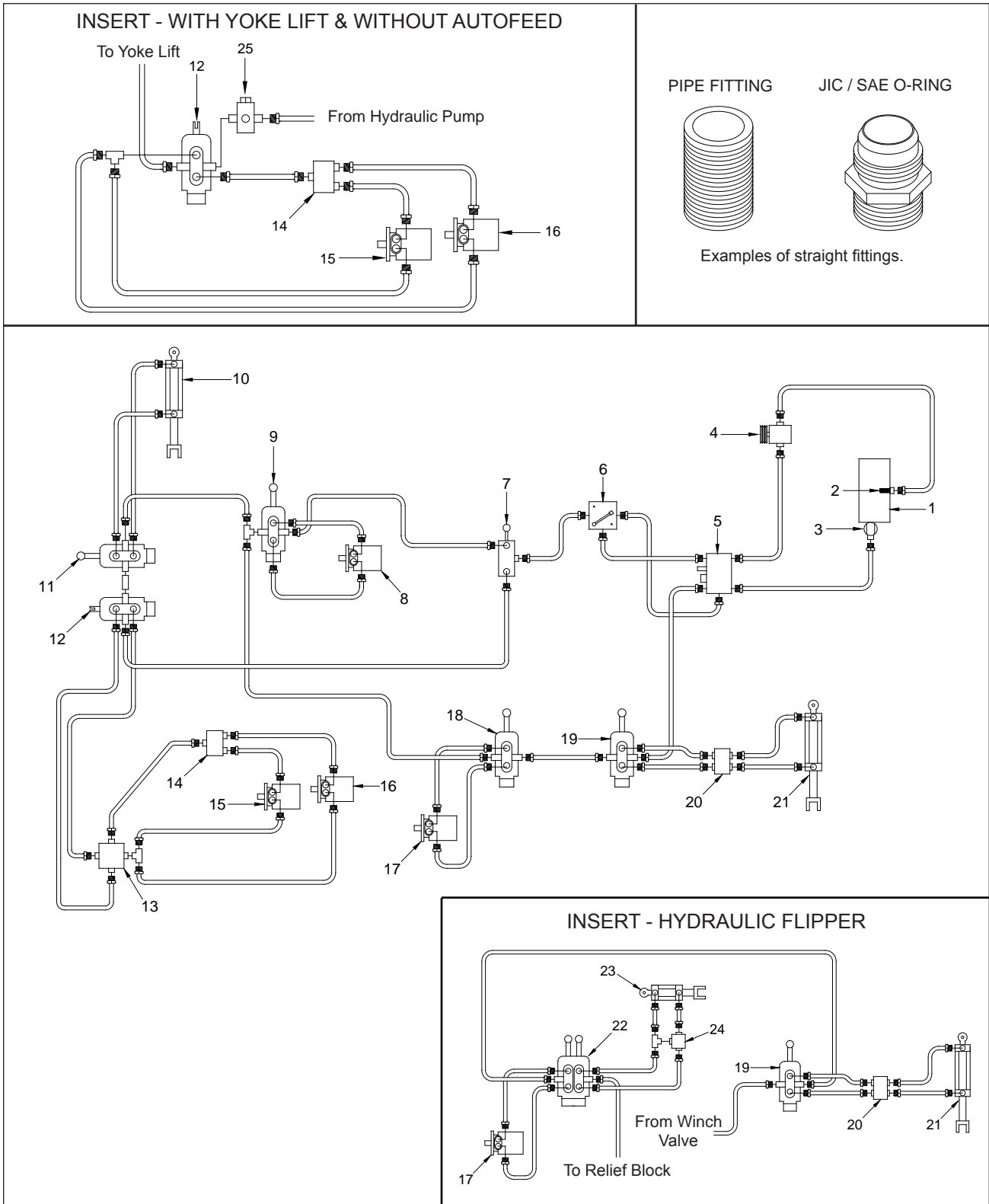

NOTE: Parts may not be exactly as shown.

Bandit

**TYPICAL MODELS 1290XP/1590
HYDRAULIC COMPONENTS (With Options)**

LOCATION	PIPE FITTING	SAE O-RING	DESCRIPTION
1.	See Pages 112-113	See Pages 112-113	Hydraulic Tank
2.	900-3903-39	N/A	Hydraulic Tank Strainer
3 a.	900-3900-09	N/A	Filter Head
b.	900-3900-10	N/A	Filter
4.	**	**	Hydraulic Pump
5.	See Pages 98-99	See Pages 98-98	Relief Block With Autofeed Option
6.	900-3901-99	900-3924-55	Variable Speed Control Valve
7 a.	900-3913-41	900-3936-39	Winch Selector Control Valve (Replaces 900-3920-58)
b.	N/A	900-3936-40	5/16" Replacement Stud For Selector Valve (900-3936-39)
c.	900-3924-48	900-3924-48	1/4" Replacement Stud For Selector Valve (900-3920-58 & 900-3913-41)
8.	900-3902-14	900-3921-57	Winch Hydraulic Motor
9.	900-3901-42	900-3920-01	Winch Control Valve
10 a.	N/A	900-3928-15	Yoke Lift Cylinder - Welded - Model 1290XP (Start 3/07)
b.	N/A	900-3925-04	Yoke Lift Cylinder - Welded - Model 1290XP (Pre 3/07)
c.	N/A	900-3925-06	Yoke Lift Cylinder - Welded - Model 1590 (Start 6/07)
d.	N/A	900-3928-15	Yoke Lift Cylinder - Welded - Model 1590 (Pre 6/07)
e.	904-0007-14	904-0007-14	Pin For Welded Cylinder (Not Shown)
f.	904-0006-90	904-0006-90	Seal Kit - Welded Lift Cylinder (Not Shown)
g.	900-3905-37	900-3905-37	Seal Kit - Tie Rod Ends Cylinder (Not Shown)
11 a.	N/A	900-3927-73	Yoke Lift Control Valve For Dual Control Yoke Lift
b.	900-3908-62	900-3920-09	Yoke Lift Control Valve With Winch Option (Model 1290XP)
c.	900-3901-24	900-3920-02	Yoke Lift Control Valve Without Winch Option (Model 1290XP)
d.	900-3908-62	900-3920-09	Yoke Lift Control Valve (Model 1590)
12.	900-3914-47	900-3920-05A	Feedwheel Control Valve Without Relief
13.	See Pages 98-99	See Pages 98-98	Reversing "Autofeed Plus"
14.	See Pages 100-101	See Pages 100-101	Flow Divider
15 a.	N/A	900-3908-67	Top Feedwheel Hydraulic Motor - Model 1290XP
b.	N/A	900-3908-67	Top Feedwheel Hydraulic Motor - Model 1590 (Start 12/05)
c.	N/A	900-3908-68	Top Feedwheel Hydraulic Motor - Model 1590 (Pre 12/05)
16 a.	N/A	900-3908-68	Bottom Feedwheel Hydraulic Motor - Model 1290XP
b.	N/A	900-3908-68	Bottom Feedwheel Hydraulic Motor - Model 1590 (Start 12/05)
c.	N/A	900-3908-67	Bottom Feedwheel Hydraulic Motor - Model 1590 (Pre 12/05)
17.	900-3902-14	900-3921-57	Swivel Discharge Hydraulic Motor
18.	900-3901-42	900-3920-01	Swivel Discharge Control Valve Only
19.	900-3901-42	900-3920-01	Tongue Jack Control Valve
20.	N/A	900-3925-94	Tongue Jack Check Valve
21.	N/A	900-3934-24	Tongue Jack Cylinder - Welded
22.	N/A	900-3916-62	Swivel Discharge & Discharge Flipper Control Valve
23.	900-3928-16	N/A	Discharge Flipper Cylinder
24.	900-3925-18	N/A	Flipper Check Valve
25.	900-3907-31	N/A	Relief Block - Machines With Yoke Lift & Without Autofeed
26.	900-3901-42	900-3920-01	Articulating Tongue Control Valve - Model 1590 Only (Not Shown)
27.	900-3906-27	N/A	Articulating Tongue Cylinder - Model 1590 Only (Not Shown)
28 a.	N/A	980-100121	In-Line Pressure Check Kit - With Autofeed (Not Shown)
b.	N/A	980-100122	In-Line Pressure Check Kit - Without Autofeed (Not Shown)
c.	N/A	900-3935-13	In-Line Pressure Check Kit - Pre Horizontal Winch Mount (Not Shown)

NOTE: Make sure to order components according to fitting type, fittings may vary on all components.

**** Hydraulic components, fittings, hoses will vary depending on optional equipment. Order by physical description.**

**** Hydraulic pumps need to be ordered by physical description and serial number of machine.**

Bandit

RELIEF BLOCK

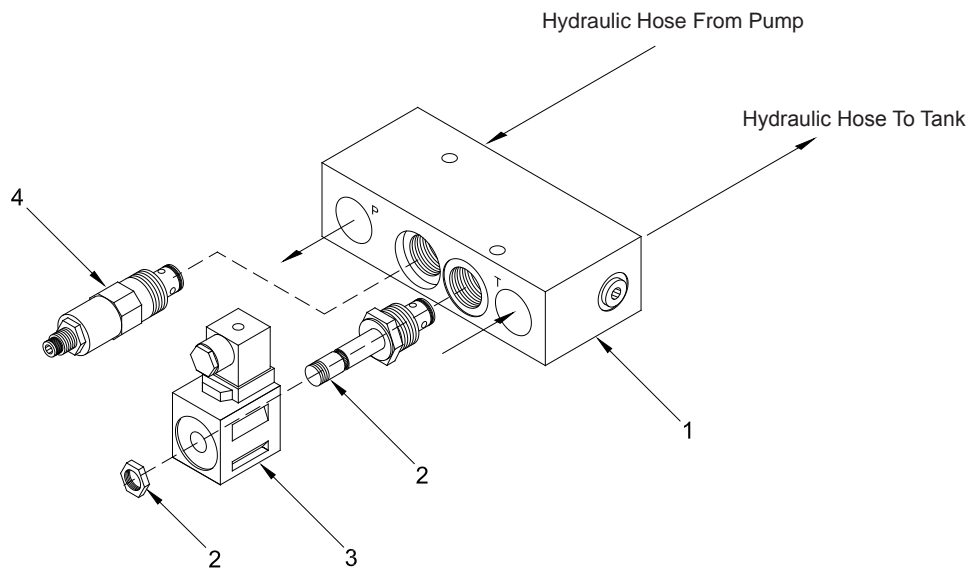

Torque Autofeed Cartridge Nut to a Maximum of 4 to 6 ft.-lbs. (5 to 8 Nm) and Install Loc-Tite 241. Over Torque Will Cause Damage and Will Also Void Warranty.

**“AUTO FEED PLUS” SYSTEM
(SINGLE SOLENOID)**

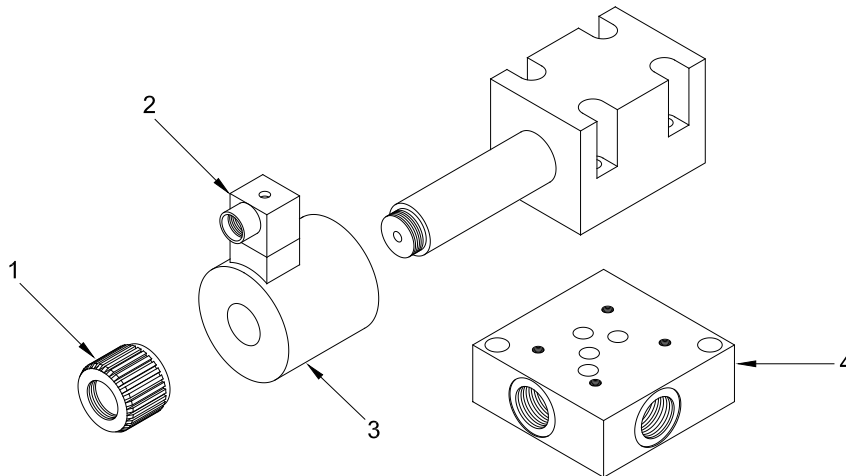

Torque Retainer Nut to a Maximum of 4 to 6 ft.-lbs. (5 to 8 Nm) and Install Vibra Tite. Over Torque Will Cause Damage and Will Also Void Warranty.

NOTE: Parts may not be exactly as shown.

RELIEF BLOCK

LOCATION	PIPE FITTING	SAE O-RING	DESCRIPTION
1.	900-2900-82	N/A	Autofeed Block Only
2.	900-3923-47	900-3923-47	Autofeed Cartridge Only
3.	900-3923-44	900-3923-44	12 V Autofeed Solenoid Only
4 a.	900-3908-23	900-3908-23	Main Relief Only (Vickers)
b.	900-3919-96	900-3919-96	Main Relief Only (Danfoss)
5 a.	900-3910-68	900-3923-46	Autofeed Block Assembly With Relief
b.	900-3910-69	900-3923-46	Autofeed Block Assembly Without Lift Cylinder
c.	900-3909-05	900-3923-48	Main Relief Block Ass'y (Used Without Autofeed)

“AUTO FEED PLUS” SYSTEM (SINGLE SOLENOID)

LOCATION	PART NUMBER	DESCRIPTION
1 a.	900-3915-19	Retainer Nut (Northman)
b.	900-3920-20	Retainer Nut and Sealing Ring (Danfoss)
2.	900-2909-55	Herschman Connector Only
3 a.	900-3915-20	Solenoid Only (Northman)
b.	900-3920-19	Solenoid Only (Danfoss)
4 a.	900-3918-43	Autofeed Plus Relief Block Subplate (DTS)
b.	900-3923-34	Autofeed Plus Relief Block Subplate (Edmore)
5 a.	900-3918-39	Solenoid Assembly (Northman Includes #'s 1,2,3, & 6)
b.	900-3919-73	Solenoid Assembly (Danfoss Includes #'s 1,2,3, & 6)
6.	900-3915-39	Seal Kit (Not Shown)
7 a.	900-3925-89	10' Cord and Molded Herschman Connector (Not Shown)
b.	900-3920-71	16' Cord and Molded Herschman Connector (Not Shown)
c.	900-3918-63	25' Cord and Molded Herschman Connector (Not Shown)

HOSE CLAMP

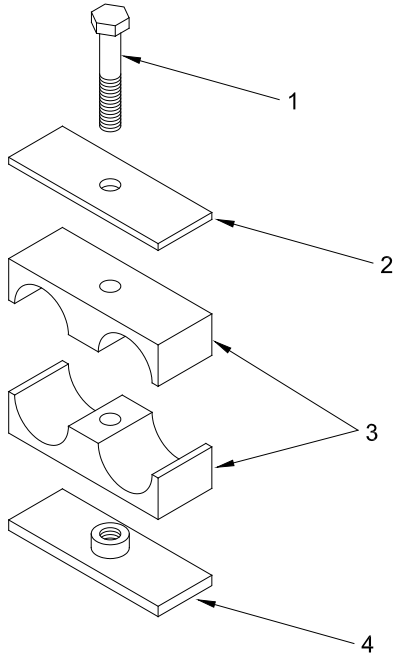

HOSE GUARD

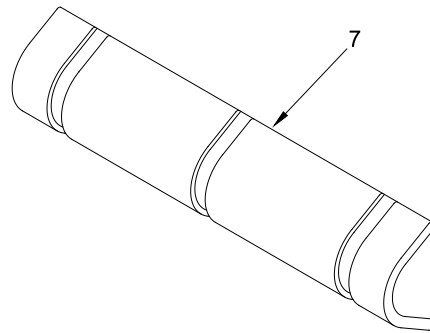

FLOW DIVIDER

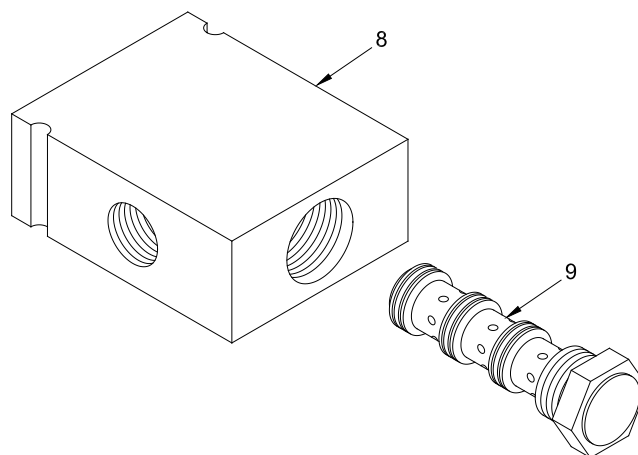

NOTE: Parts may not be exactly as shown.

Bandit

HOSE CLAMP

LOCATION	PART NUMBER	DESCRIPTION
1.	N/A	Bolt
2.	N/A	Locking Plate
3.	N/A	Plastic Clamp
4 a.	900-3914-09	Weld Plate for 1/4" Double Clamp
b.	900-3914-08	Weld Plate for 1/2" Double Clamp
c.	900-3926-47	Weld Plate for 3/4" Double Clamp
5 a.	900-3917-25	1/4" Double Clamp Assembly (Includes #'s 1-4)
b.	900-3926-44	3/8" Double Clamp Assembly (Includes #'s 1-4)
c.	900-3928-19	1/2" Single Clamp Assembly (Includes #'s 1-4)
d.	900-3914-02	1/2" Single Clamp Assembly For Steel Lines (Includes #'s 1-4)
e.	900-3915-61	1/2" Double Clamp Assembly (Includes #'s 1-4)
f.	900-3913-32	1/2" Double Clamp Assembly For Steel Lines (Includes #'s 1-4)
g.	900-3914-03	3/4" Single Clamp Assembly (Includes #'s 1-4)
h.	900-3914-07	3/4" Double Clamp Assembly (Includes #'s 1-4)
i.	900-3914-04	1" Single Clamp Assembly (Includes #'s 1-4)
j.	900-3914-05	1 1/4" Single Clamp Assembly (Includes #'s 1-4)
k.	900-3914-06	1 1/2" Single Clamp Assembly (Includes #'s 1-4)
6 a.	900-3914-10	Stacking Bolt for 1/2" Double Clamp (Not Shown)
b.	900-3920-11	Stacking Bolt for 3/4" Double Clamp (Not Shown)

HOSE GUARD

LOCATION	PART NUMBER	DESCRIPTION
7 a.	900-3934-76	Hose Guard - 4" Long
b.	900-3934-77	Hose Guard - 6" Long
c.	900-3934-78	Hose Guard - 8" Long

FLOW DIVIDER

LOCATION	PART NUMBER	DESCRIPTION
8 a.	900-3924-59	Flow Divider Body With Cartridge - Sauer/Danfoss #66 (Start 5/03)
b.	900-3919-21	Flow Divider Body With Cartridge - Vickers #66 (Start 5/03)
c.	900-3901-40	Flow Divider Body With Cartridge - Vickers #44 (Pre 5/03)
9 a.	900-3934-30	Cartridge Only - Sauer/Danfoss #66 (Start 5/03)
b.	900-3917-20	Cartridge Only - Vickers #66 (Start 5/03)
c.	900-3907-18	Cartridge Only - Vickers #44 (Pre 5/03)

NOTE: Flow Dividers On Model 1290XP Started S/N 7071

TYPICAL SPRING LOADED CONTROL VALVE

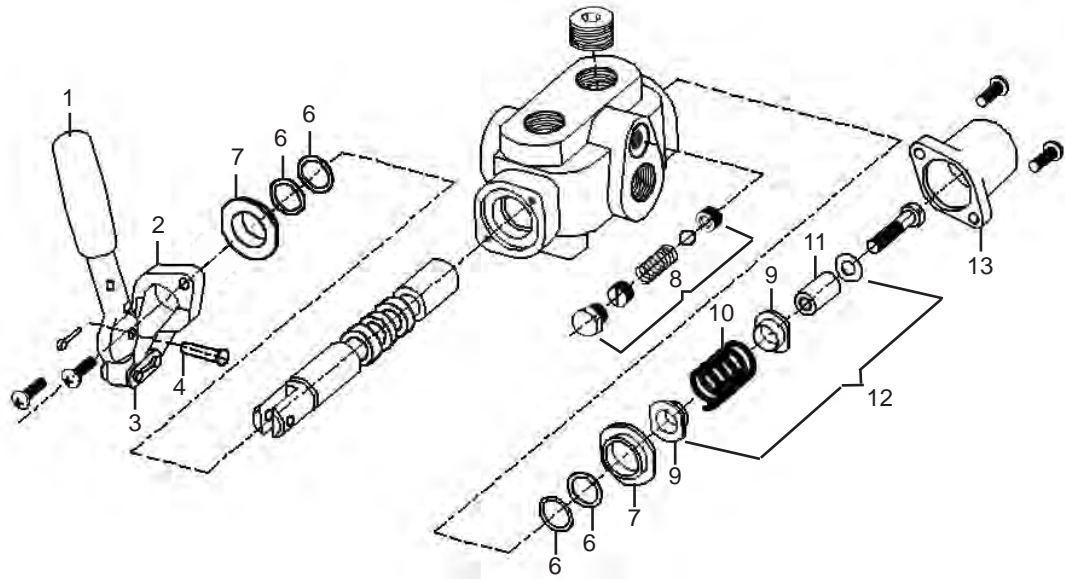

TYPICAL FEEDWHEEL CONTROL VALVES

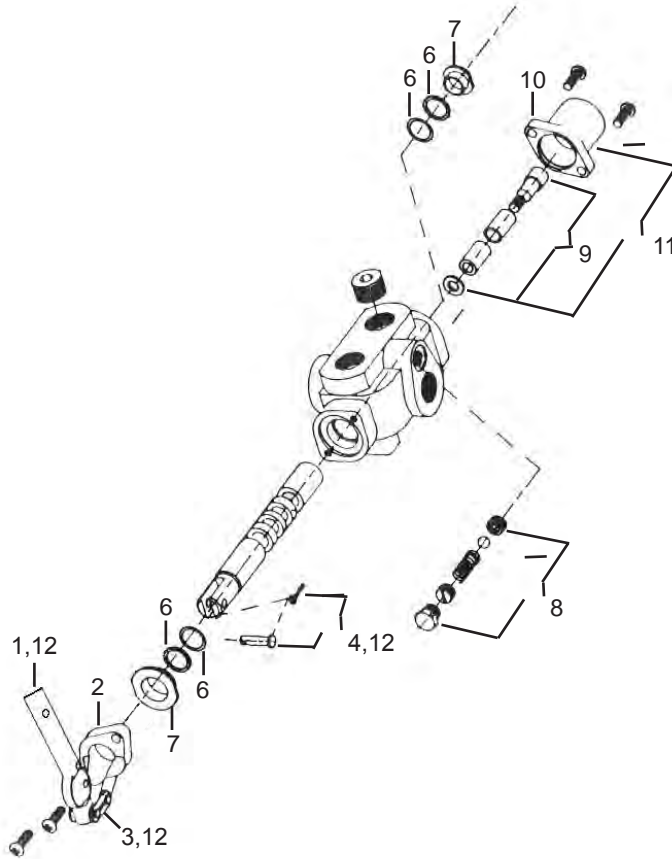

NOTE: Parts may not be exactly as shown.

TYPICAL SPRING LOADED CONTROL VALVE COMPONENTS

LOCATION	PART NUMBER	DESCRIPTION
1.	904-0003-29	Handle Only (Long)
2.	900-3905-95	Valve Bracket Only With Screws
3.	904-0003-30	Master Link Only Control Valve
4.	904-0003-31	Pin And Cotter Key For Control Valve
5.	904-0003-32	Bracket, Handle And Chain Link NOTE: INCLUDES #s 1, 2, 3, 4
6.	900-3937-34	Seal Kit For Control Valve
7.	904-0003-33	Seal Retainer For Control Valve NOTE: NOT INCLUDED IN SEAL KIT
8.	900-3901-12	Relief Valve Kit - Spring, Ball, Screw NOTE: SOLD ONLY AS A KIT
9.	904-0003-34	Valve Spool Stop For Spring Loaded Valve
10.	904-0003-35	Valve Spool Spring
11.	904-0003-36	Valve Spacer For Yoke Lift Valve
12.	900-A-2941	Spring Center Kit For Spring Loaded Valve
13.	904-0003-37	Detent Cap Only For Spring Loaded Valve (Short)

TYPICAL FEEDWHEEL CONTROL VALVE COMPONENTS

LOCATION	PART NUMBER	DESCRIPTION
1.	900-3905-95H	Handle Only (Short)
2.	900-3905-95	Valve Bracket Only With Screws
3.	904-0003-30	Master Link Only Control Valve
4.	904-0003-31	Pin And Cotter Key For Control Valve
5.	904-0003-32	Bracket, Handle And Chain Link NOTE: INCLUDES #s 1, 2, 3, 4
6.	900-3937-34	Seal Kit For Control Valve
7.	904-0003-33	Seal Retainer For Control Valve NOTE: NOT INCLUDED IN SEAL KIT
8.	900-3901-12	Relief Valve Kit - Spring, Ball, Screw NOTE: SOLD ONLY AS A KIT
9.	900-3900-71	Detent Kit For Feedwheel Control Valve NOTE: SOLD ONLY AS A KIT
10.	900-390071C	Detent Cap Only With Screws (Long)
11.	900-3900-71E	Detent Kit With Cap And Screws NOTE: INCLUDES #s 9 & 10
12.	900-3905-59	Handle, Pin, and Link NOTE: INCLUDES #s 1, 3, & 4

CONTROL VALVES

LOCATION	PIPE FITTING	SAE O-RING	DESCRIPTION
1.	N/A	900-3927-73	Yoke Lift Control Valve for Dual Control Yoke Lift
2.	900-3901-24	900-3920-02	Yoke Lift Control Valve Without Winch Option (Model 1290XP)
3.	900-3908-62	900-3920-09	Yoke Lift Control Valve With Winch Option (Model 1290XP)
4.	900-3908-62	900-3920-09	Yoke Lift Control Valve (Model 1590)
5.	900-3901-42	900-3920-01	Winch, Hyd. Swivel Discharge, and Articulating Tongue
6.	900-3909-89	900-3920-06A	Feedwheel Control Valve With Relief
7.	900-3914-47	900-3920-05A	Feedwheel Control Valve With Out Relief

MODEL 1290XP

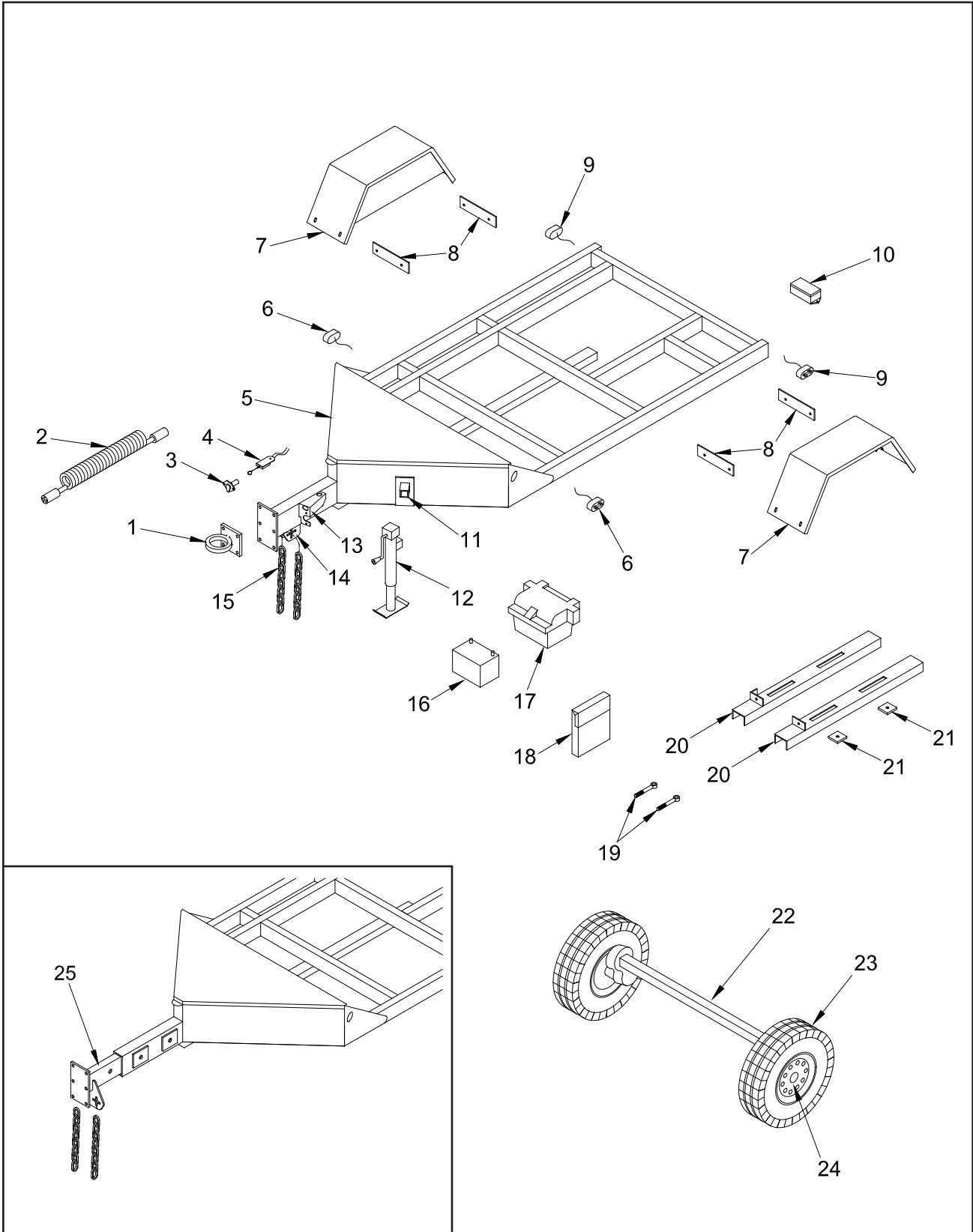

NOTE: Parts may not be exactly as shown.

Bandit

MODEL 1290XP

LOCATION	PART NUMBER	DESCRIPTION
1 a.	900-5900-13	2 1/2" Heavy Duty Pintle Ring Hitch
b.	900-5905-73	3" Heavy Duty Pintle Ring Hitch
c.	980-0505-33	2 5/16" Ball Coupler Assembly
d.	980-0501-47	2" Ball Coupler Assembly
e.	*-*	Other Hitch Options Available
2 a.	900-2916-63	Coil Cable Assembly With 6 Prong Plugs - 15'
b.	900-2904-12	6-Prong Trailer Plug Male Plug Only
3.	900-2904-13	6-Prong Trailer Plug Female Plug Only
4.	900-5900-09	Electrical Breakaway Switch
5.	912-1001-24	Tool Box Lid
6.	900-2915-97	LED Amber Marker Light
7.	900-5904-43	Aluminum Fender Assembly
8 a.	911-1002-84	Fender Mount For 8000 Lbs. Axle
b.	980-0128-14	Fender Mount For 7000 Lbs. Axle
9.	900-2915-98	LED Red Marker Light
10.	900-2902-41	Junction Box for Wiring
11 a.	900-5905-71	Pivot Mount For 5,000 Lbs. Jack
b.	980-0127-45	Mount For 8,000 Lbs. Drop Leg Jack
c.	980-0127-44	Pin For 8,000 Lbs. Drop Leg Jack
12 a.	900-5908-44	5,000 Lbs. Side Crank Jack - Zinc (Start S/N 7237)
b.	900-5906-11	5,000 Lbs. Top Crank Jack - Zinc (Replaces 900-5905-70) (Pre S/N 7237)
c.	900-5903-78	8,000 Lbs. Drop Leg Jack - Optional
13.	980-300106	Trailer Plug Receptacle Mount
14.	980-0121-31	Safety Chain Holder
15 a.	900-4912-71	Safety Chain W / Hooks and Spring Latches for Standard Tongue
b.	900-4912-38	Safety Chain W / Hooks and Spring Latches for Telescopic Tongue
c.	900-4905-77	Hook For Safety Chain
16.	900-6900-02	660 CCA Battery
17 a.	900-7900-08	Plastic Battery Liner Box for 660 CCA Battery
b.	900-6907-88	1400 CCA Battery (Cummins Tier 3)
18.	900-9902-07	Manual Holder
19 a.	900-4905-11	Engine Adjuster Rod End - 5/8"-11NC X 6"
b.	900-4902-29	Engine Adjuster Rod End - 1/2"-13NC X 6"
c.	900-4902-28	Engine Adjuster Rod End - 1/2"-13NC X 8 1/2"
20.	*-*	Engine Rails
21 a.	922-0003-38	Engine Mount Pad For 1/2" Engine Hold Down
b.	980-0101-33	Engine Mount Pad For 5/8" Engine Hold Down
22 a.	900-5904-55	8000 Lb. Torflex Axle Assembly (Electric Brakes) (Start 8/06)
b.	900-5905-12	8000 Lb. Torflex Axle Assembly (Electric Brakes) (6/05 - 8/06)
c.	900-5905-43	7000 Lb. Torflex Axle Assembly (Electric Brakes) (Pre 6/05)

**** Order Brake Hub And Drum Assembly According To Axle Type.
(Grease Type, Oil Type, Never Lube Type).**

***-* Engine Rails And Adjusters Will Vary Depending On Engine And Component Options.
Order By Serial Number Of Chipper Or Physical Description.**

NOTE: Other Fenders And Fender Stone Shields Are Optional.

Bandit

MODEL 1290XP

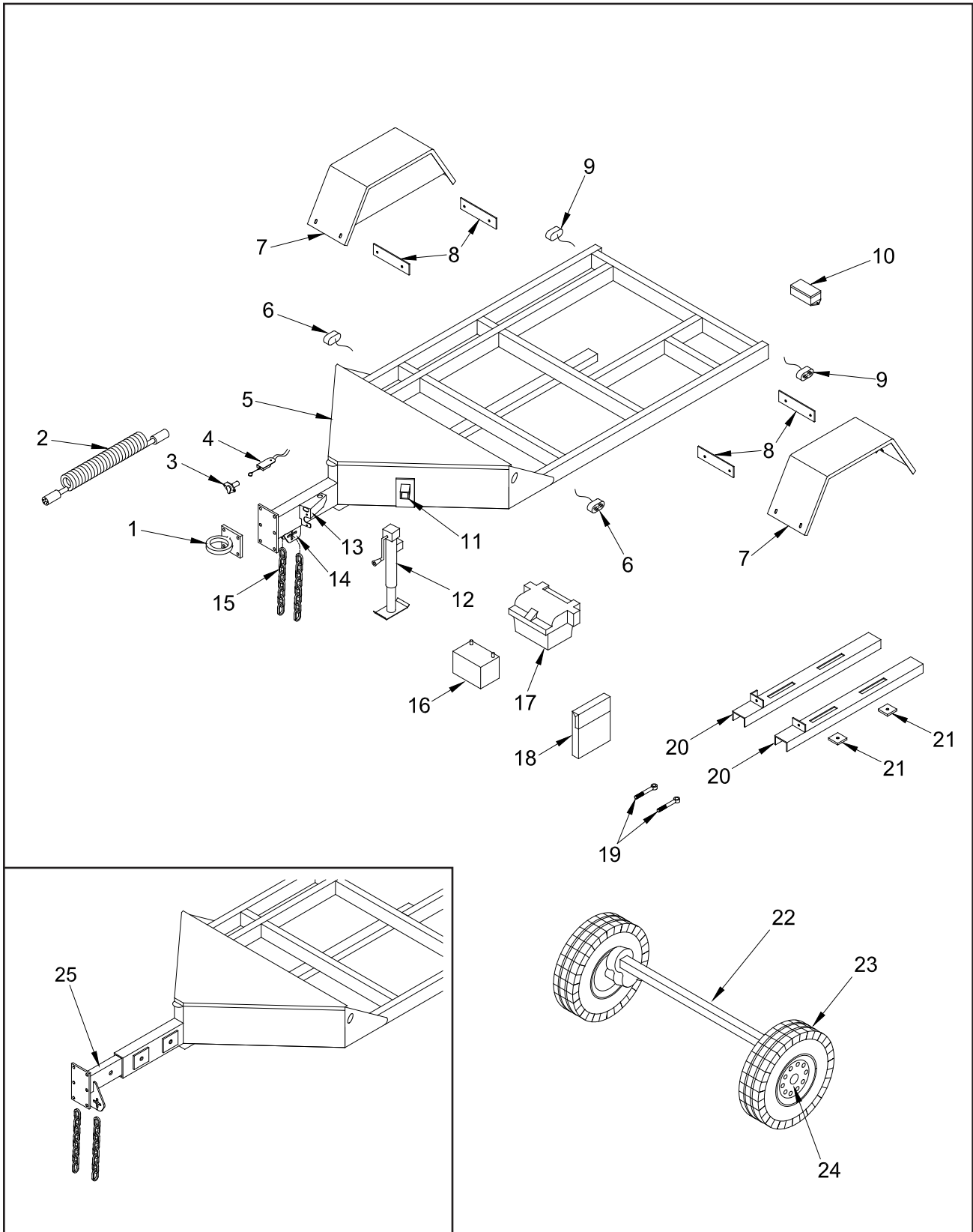

NOTE: Parts may not be exactly as shown.

Bandit

MODEL 1290XP

LOCATION	PART NUMBER	DESCRIPTION
23 a.	900-5908-39	215/75R-17.5" Tire and Solid Gray, 8-Bolt Rim (Start 8/06)
b.	900-5903-54	215/75R-17.5" Tire Only (Start 8/06)
c.	900-5904-49	17.5" x 6.75" Solid Gray, 8-Bolt Rim Only (Start 8/06)
d.	900-5905-03	235/85R-16" Tire and White Spoke, 8-Bolt Rim (Pre 8/06)
e.	900-5905-01	235/85R-16" Tire Only (Pre 8/06)
f.	900-5904-22	16" x 6" White Spoke, 8-Bolt Rim Only (Pre 8/06)
24.	**	Brake Hub and Drum Assembly
25.	912-0501-16	Telescopic Tongue Assembly
26 a.	980-0508-25	Optional Wheel Chock Holders Aluminum Bolt-On (Not Shown)
b.	980-0508-26	Optional Wheel Chock Holders Metal Weld-On (Not Shown)
27.	900-5902-32	Optional Rubber Wheel Chock (Not Shown)
28.	900-5900-62	Optional Safety Flags For Fenders (Not Shown)
29.	900-7900-48	Optional Mud Flap (Not Shown)
30 a.	900-9904-94	Optional Vice (Not Shown)
b.	980-300113	Optional Weld-On Vice Mount (Not Shown)

**** Order Brake Hub And Drum Assembly According To Axle Type.
(Grease Type, Oil Type, Never Lube Type).**

***-* Engine Rails And Adjusters Will Vary Depending On Engine And Component Options.
Order By Serial Number Of Chipper Or Physical Description.**

NOTE: Other Fenders And Fender Stone Shields Are Optional.

Bandit

MODEL 1590

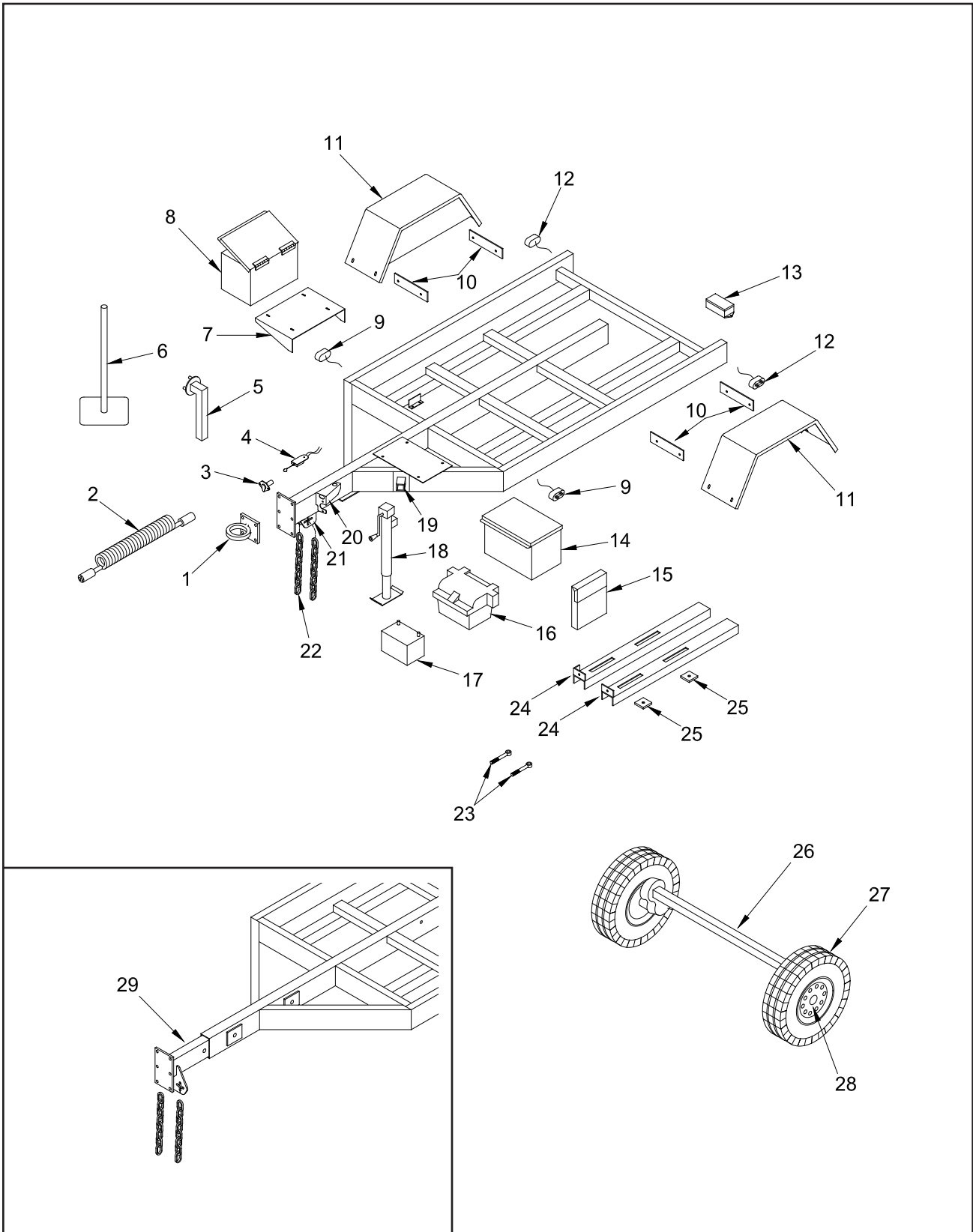

NOTE: Parts may not be exactly as shown.

Bandit

MODEL 1590

LOCATION	PART NUMBER	DESCRIPTION
1 a.	900-5900-13	2 1/2" Heavy Duty Pintle Ring Hitch
b.	900-5905-73	3" Heavy Duty Pintle Ring Hitch
c.	980-0505-33	2 5/16" Ball Coupler Assembly
d.	980-0501-47	2" Ball Coupler Assembly
e.	*-*	Other Hitch Options Available
2 a.	900-2916-63	Coil Cable Assembly With 6 Prong Plugs - 15'
b.	900-2904-12	6-Prong Trailer Plug Male Plug Only
3.	900-2904-13	6-Prong Trailer Plug Female Plug Only
4.	900-5900-09	Electrical Breakaway Switch
5.	980-0510-51	Optional Spare Tire Mount
6 a.	980-200202	Optional Cone Holder (Replaces 980-0508-30)
b.	980-200215	Optional Bolt-On Cone Holder (Not Shown)
c.	980-200107	Optional Hoop Style Cone Holder (Not Shown)
d.	900-7900-86	Cap For Cone Holder (Not Shown)
7.	980-200205	Battery / Tool Box Mount
8 a.	900-7900-78	Aluminum Tool Box
b.	980-0508-37	Steel Tool Box
9.	900-2915-97	LED Amber Marker Light
10 a.	911-1002-84	Fender Mount For 8000 lb. Axle
b.	980-0128-14	Fender Mount For 7000 lb. Axle
11.	900-5904-43	Aluminum Fender Assembly
12.	900-2915-98	LED Red Marker Light
13.	900-2902-41	Junction Box for Wiring
14 a.	900-7900-78B	Aluminum Battery Box For 660 CCA Battery And Manual Holder
b.	980-0509-37	Steel Battery Box For 660 CCA Battery And Manual Holder
c.	914-0501-46	Steel Battery Box For 1400 CCA Battery And Manual Holder (Cummins Tier 3)
15.	900-9902-07	Manual Holder
16.	900-7900-08	Plastic Battery Liner Box for 660 CCA Battery
17 a.	900-6900-02	660 CCA Battery
b.	900-6907-88	1400 CCA Battery (Cummins Tier 3)
18 a.	900-5903-78	8,000 Lbs. Drop Leg Jack
b.	900-5903-86	5,000 Lbs. Side Crank Jack
19 a.	980-0127-45	Mount For 8,000 Lbs. Drop Leg Jack
b.	980-0127-44	Pin For 8,000 Lbs. Drop Leg Jack
c.	937-1002-31	Pivot Mount For 5,000 Lbs. Side Crank Jack
20.	980-300106	Trailer Plug Receptacle Mount
21.	980-0121-31	Safety Chain Holder
22 a.	900-4912-71	Safety Chain W / Hooks and Spring Latches for Standard Tongue
b.	900-4912-38	Safety Chain W / Hooks and Spring Latches for Telescopic Tongue
c.	900-4905-77	Hook For Safety Chain
23 a.	900-4905-11	Engine Adjuster Rod End - 5/8"-11NC X 6"
b.	900-4902-29	Engine Adjuster Rod End - 1/2"-13NC X 6"
c.	900-4902-28	Engine Adjuster Rod End - 1/2"-13NC X 8 1/2"
24.	*-*	Engine Rails
25 a.	922-0003-38	Engine Mount Pad For 1/2" Engine Hold Down
b.	980-0101-33	Engine Mount Pad For 5/8" Engine Hold Down

**** Order Brake Hub And Drum Assembly According To Axle Type.
(Grease Type, Oil Type, Never Lube Type).**

***-* Engine Rails And Adjusters Will Vary Depending On Engine And Component Options.**

Order By Serial Number Of Chipper Or Physical Description.

NOTE: Other Fenders And Fender Stone Shields Are Optional.

Bandit

MODEL 1590

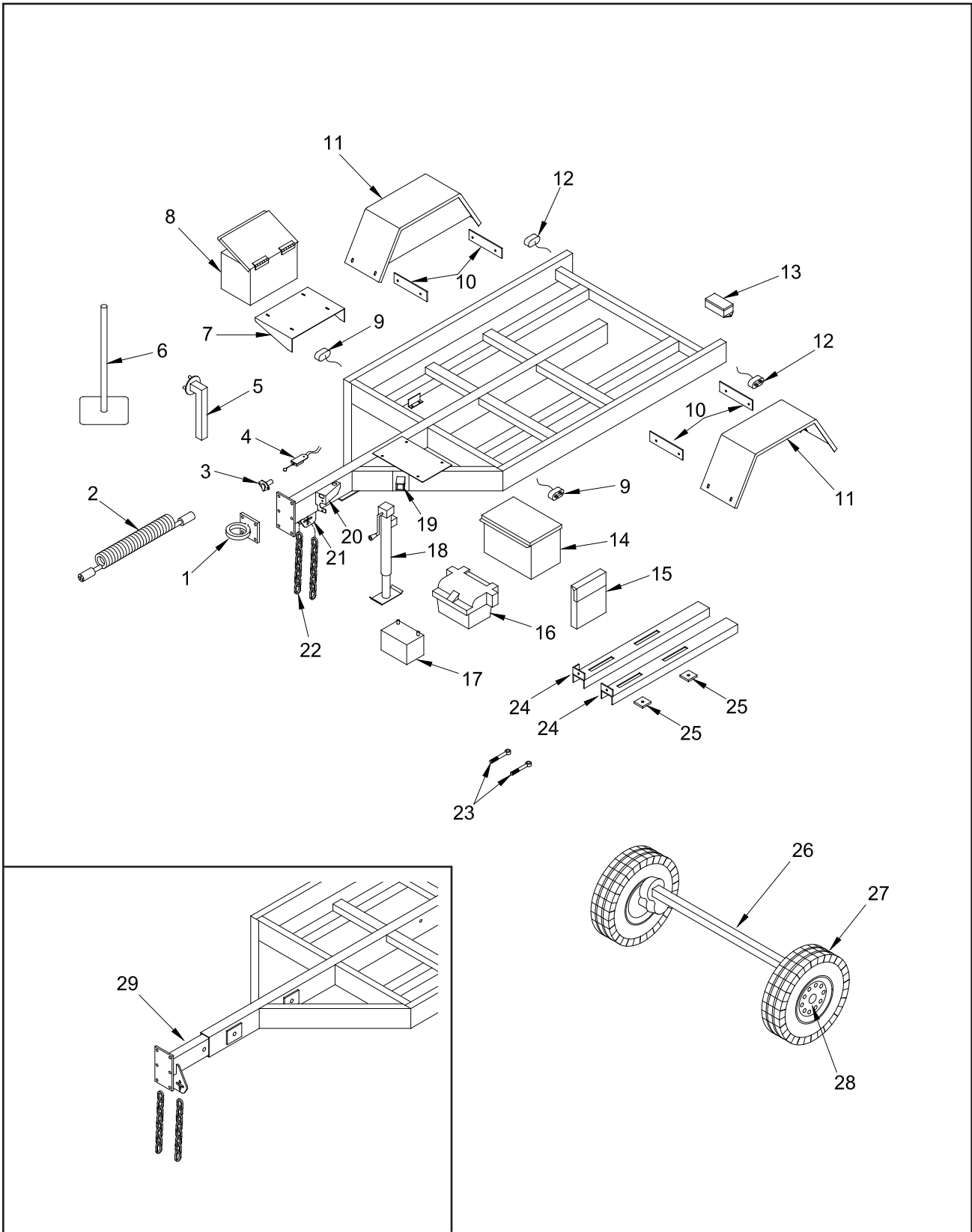

NOTE: Parts may not be exactly as shown.

Bandit

MODEL 1590

LOCATION	PART NUMBER	DESCRIPTION
26 a.	900-5904-55	8,000 Lbs. Torflex Axle Assembly (Electric Brakes) (Start 8/06)
b.	900-5905-12	8,000 Lbs. Torflex Axle Assembly (Electric Brakes) (12/04 - 8/06)
c.	900-5902-70	7,000 Lbs. Torflex Axle Assembly (Electric Brakes) (Pre 12/04)
27 a.	900-5908-39	215/75R-17.5" Tire and Solid Gray, 8-Bolt Rim (Start 8/06)
b.	900-5903-54	215/75R-17.5" Tire Only (Start 8/06)
c.	900-5904-49	17.5" x 6.75" Solid Gray, 8-Bolt Rim Only (Start 8/06)
d.	900-5905-03	235/85R-16" Tire and White Spoke, 8-Bolt Rim (Pre 8/06)
e.	900-5905-01	235/85R-16" Tire Only (Pre 8/06)
f.	900-5904-22	16" x 6" White Spoke, 8-Bolt Rim Only (Pre 8/06)
28.	**	Brake Hub and Drum Assembly
29.	981-0501-18	Telescopic Tongue Assembly
30 a.	980-0508-25	Optional Wheel Chock Holders Aluminum Bolt-On (Not Shown)
b.	980-0508-26	Optional Wheel Chock Holders Metal Weld-On (Not Shown)
31.	900-5902-32	Optional Rubber Wheel Chock (Not Shown)
32.	900-5900-62	Optional Safety Flags For Fenders (Not Shown)
33.	900-7900-48	Optional Mud Flap (Not Shown)
34 a.	900-9904-94	Optional Vice (Not Shown)
b.	980-300113	Optional Weld-On Vice Mount (Not Shown)

**** Order Brake Hub And Drum Assembly According To Axle Type.
(Grease Type, Oil Type, Never Lube Type).**

***-* Engine Rails And Adjusters Will Vary Depending On Engine And Component Options.**

Order By Serial Number Of Chipper Or Physical Description.

NOTE: Other Fenders And Fender Stone Shields Are Optional.

Bandit

MODEL 1290XP TANKS & COMPONENTS

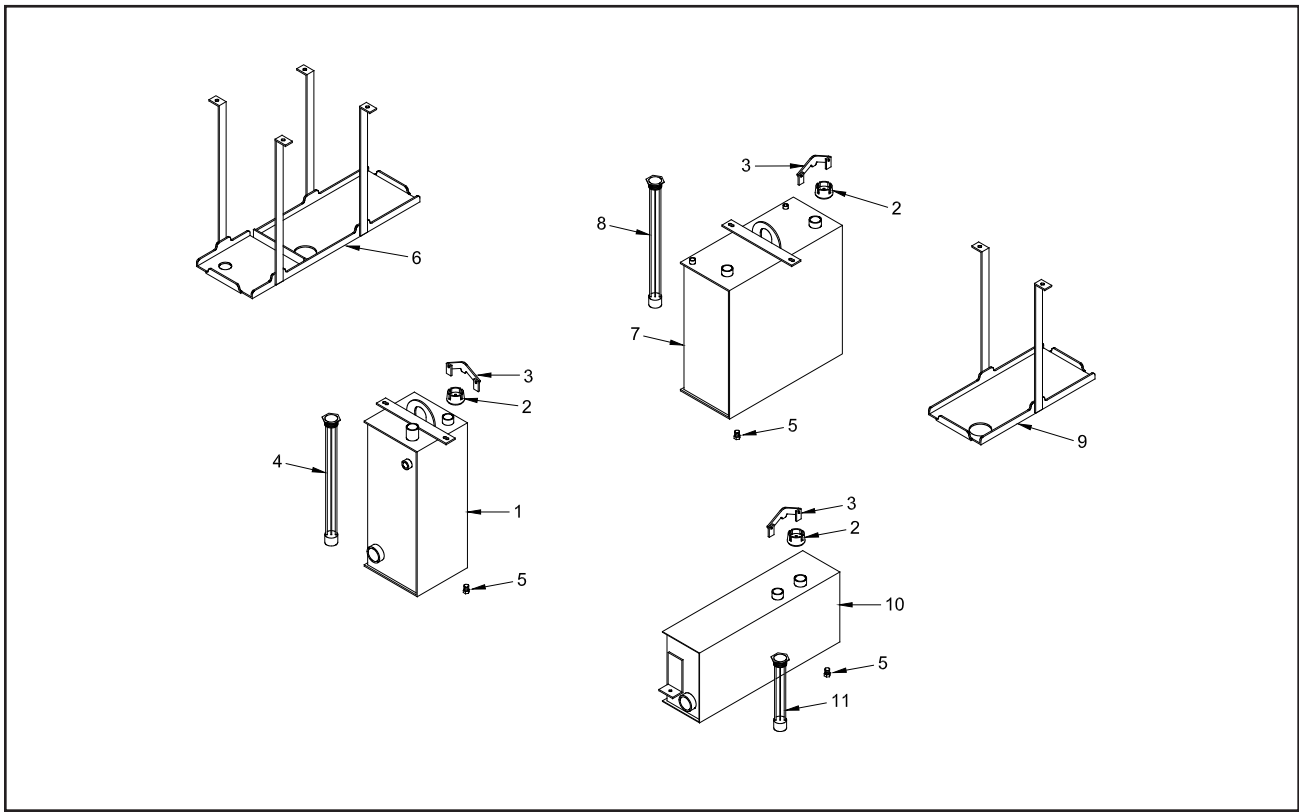

LOCATION	MODEL 1290XP PART NUMBER	DESCRIPTION
1.	912-200010	12 Gallon Hydraulic Tank Assembly (Start S/N 7111, 5/05)
2 a.	900-3934-56	Fuel (Diesel) Locking Fill Cap - Green (Replaces 900-3917-71)
b.	900-3934-55	Fuel (Gasoline) Locking Fill Cap - Black (Replaces 900-3917-71)
c.	900-3934-55	Hydraulic Locking Fill Cap - Black (Replaces 900-3917-71)
d.	900-3935-06	Keeper For Fuel & Hydraulic Locking Fill Cap (Not Shown)
3.	980-0506-85	Fill Cap Lock Assembly for Steel Tank With 900-3917-71 Fill Cap
4.	900-2903-95	Rochester Sight Gauge For 12 Gallon Hydraulic Tank (Start S/N 7111, 5/05)
5.	900-3922-60	Magnetic Drain Plug
6 a.	912-200011	24 1/2 Gallon Fuel Tank & 12 Gallon Hydraulic Tank Mount
b.	900-0104-95	Rubber Fuel Tank Pad (Not Shown)
7.	980-0509-58	24 1/2 Gallon Fuel Tank Assembly
8.	900-2903-95	Rochester Sight Gauge For 24 1/2 Gallon Fuel Tank
9 a.	980-0508-41	24 1/2 Gallon Fuel Tank Mount
b.	900-0104-95	Rubber Fuel Tank Pad (Not Shown)
10.	911-0500-16	12 Gallon Hydraulic Tank Assembly (Pre S/N 7110, 5/05)
11.	900-2903-93	Rochester Sight Gauge For 12 Gallon Hydraulic Tank (Pre S/N 7110, 5/05)
12 a.	900-4912-40	Padlock For Tank With Short Shackle For Locking Cap (Not Shown)
b.	P812	Key For Padlock (Not Shown)

**NOTE: Components vary with fuel type.
Specify gas or diesel when ordering fuel tank components.**

NOTE: Parts may not be exactly as shown.

Bandit

MODEL 1590 TANKS & COMPONENTS

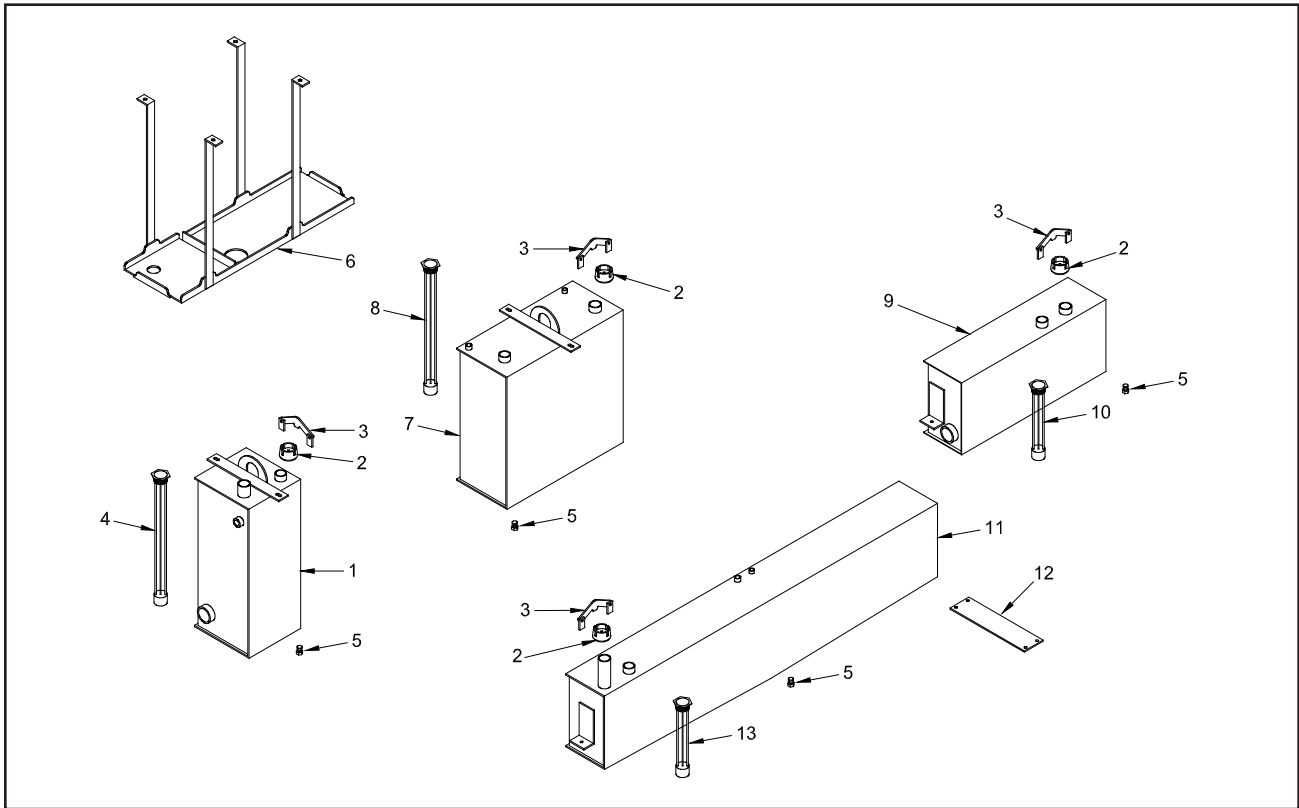

LOCATION	MODEL 1590 PART NUMBER	DESCRIPTION
1.	912-200010	12 Gallon Hydraulic Tank Assembly (Start 12/05)
2 a.	900-3934-56	Fuel (Diesel) Locking Fill Cap - Green (Replaces 900-3917-71)
b.	900-3934-55	Fuel (Gasoline) Locking Fill Cap - Black (Replaces 900-3917-71)
c.	900-3934-55	Hydraulic Locking Fill Cap - Black (Replaces 900-3917-71)
d.	900-3935-06	Keeper For Fuel & Hydraulic Locking Fill Cap (Not Shown)
3.	980-0506-85	Fill Cap Lock Assembly for Steel Tank With 900-3917-71 Fill Cap
4.	900-2903-95	Rochester Sight Gauge For 12 Gallon Hydraulic Tank (Start 12/05)
5.	900-3922-60	Magnetic Drain Plug
6 a.	911-200014	30 Gallon Fuel Tank & 12 Gallon Hydraulic Tank Mount (Start 12/05)
b.	900-0104-95	Rubber Fuel Tank Pad (Not Shown)
7.	911-200013	30 Gallon Fuel Tank Assembly (Start 12/05)
8.	900-2904-14	Rochester Sight Gauge For 30 Gallon Fuel Tank (Start 12/05)
9.	911-0500-16	12 Gallon Hydraulic Tank Assembly (Pre 12/05)
10.	900-2903-93	Rochester Sight Gauge For 12 Gallon Hydraulic Tank (Pre 12/05)
11.	911-0500-17	30 Gallon Fuel Tank Assembly (Pre 12/05)
12 a.	911-1001-93	Fuel Tank Brace
b.	900-0104-95	Rubber Fuel Tank Pad (Not Shown)
13.	900-2903-93	Rochester Sight Gauge For 30 Gallon Fuel Tank (Pre 12/05)
14 a.	900-4912-40	Padlock For Tank With Short Shackle For Locking Cap (Not Shown)
b.	P812	Key For Padlock (Not Shown)

**NOTE: Components vary with fuel type.
Specify gas or diesel when ordering fuel tank components.**

NOTE: Parts may not be exactly as shown.

Bandit

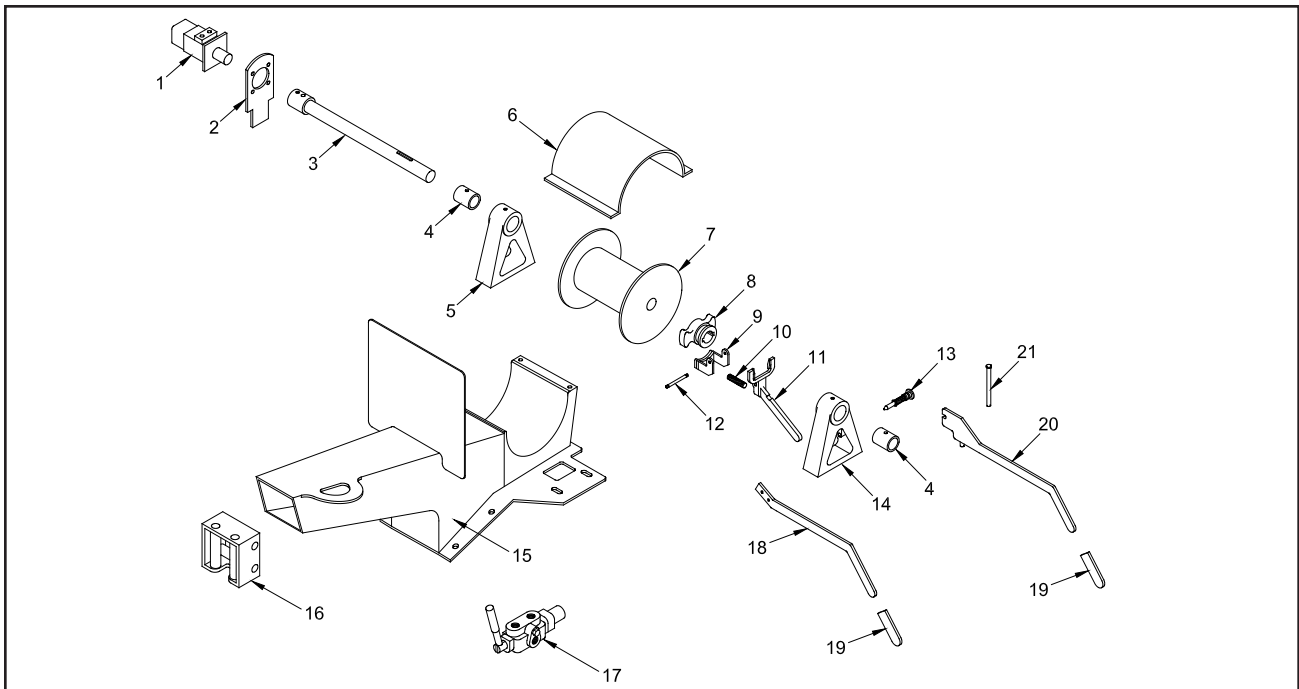

LOCATION	PART NUMBER	DESCRIPTION
1 a.	900-3921-57	Winch Hydraulic Motor (SAE O-rings) "RS" - Square
1 b.	900-3902-14	Winch Hydraulic Motor (Pipe Fittings) "RS" - Square
1 c.	900-3924-39	Winch Hydraulic Motor (SAE O-rings) "RE" - Round
2 a.	981-1001-01	Winch Motor Torque Arm For "RS" Motor
2 b.	955-1011-71	Winch Motor Torque Arm For "RE" Motor
3 a.	43626	Winch Shaft Only
3 b.	900-3905-22	Winch Shaft With Keys
4.	40003	Winch Bushing For A Frame
5.	900-3905-21	Winch A Frame Arm (Also Includes # 4)
6.	980-300260	Winch Drum Cover
7.	900-3905-19	Winch Drum
8.	900-3905-17	Winch Clutch
9.	40473	Winch Brake Shoe Only
10.	40024	Winch Spring
11 a.	40469	Winch Shift Lever Only
11 b.	900-3905-16	Winch Shift Lever With #'s 9 & 10
12 a.	40025	Winch Pin For Brake Assembly
12 b.	41669	Winch Snap Ring For Winch Pin
13.	900-3905-14	Winch Release Lever Pin Assembly
14.	900-3905-18	Winch Arm (Includes #'s 4, 9 - 13)
15 a.	980-200162	Winch Tunnel Assembly
15 b.	920-200027	Winch Tunnel Assembly For Machine With Loader (Not Shown)
16 a.	980-0505-82	Winch Roller Assembly
16 b.	914-1004-18	Winch Roller Only
16 c.	914-1004-21	Winch Roller Bolt Only
17 a.	900-3920-01	Winch Valve (SAE O-rings)
17 b.	900-3901-42	Winch Valve (Pipe Fittings)
18.	955-300376	Winch Shift Lever Extension (If Applicable)
19.	900-9904-59	Vinyl Cap For Handle Extension (If Applicable)
20.	955-300377	Lock Pin Handle Extension (If Applicable)
21.	900-4913-00	Pivot Pin For Winch Handle Extension (If Applicable)
22.	904-0002-60	Winch Kit (Includes #'s 1 - 17)

NOTE: Parts may not be exactly as shown.

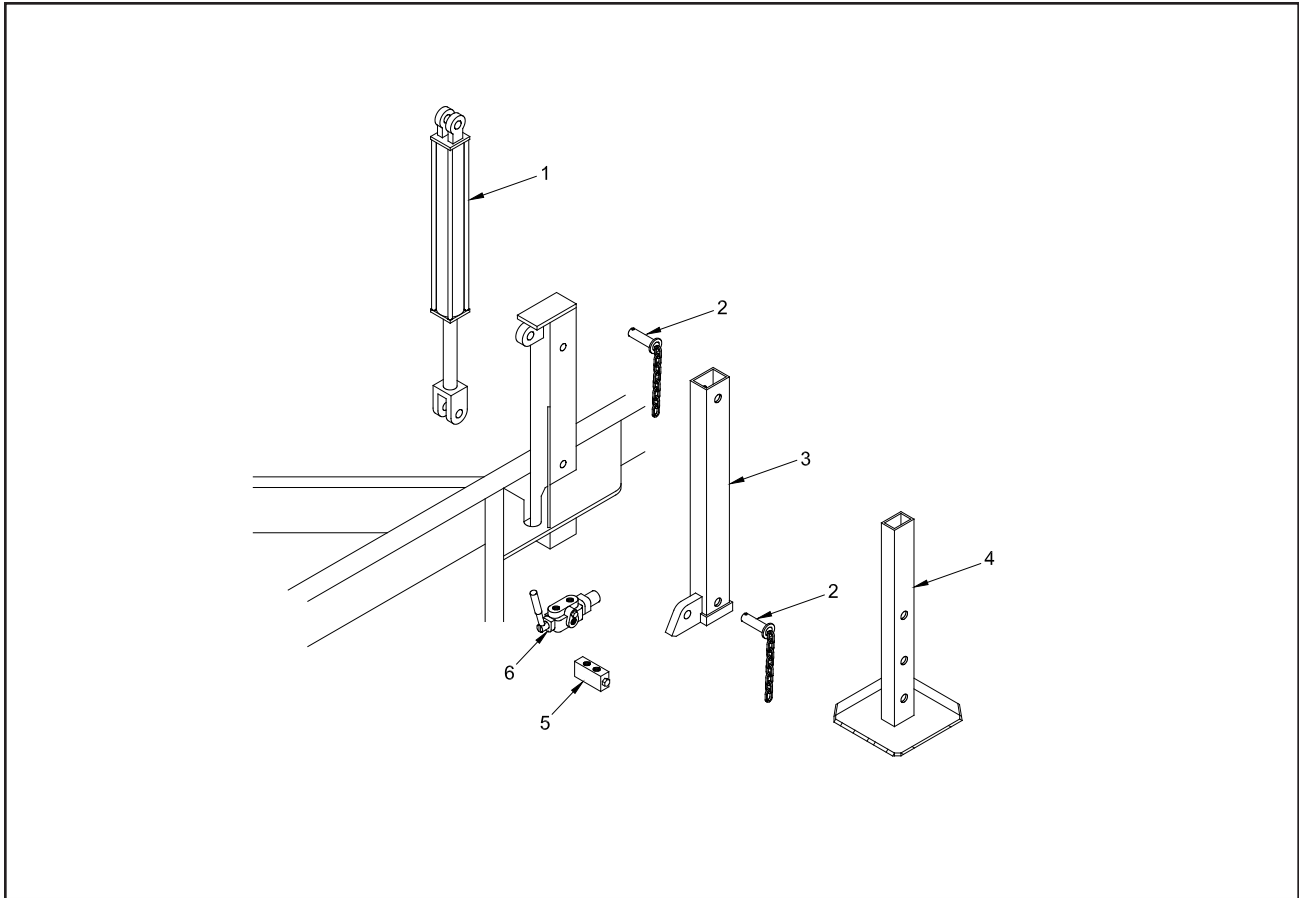

LOCATION	PART NUMBER	DESCRIPTION
1 a.	900-3934-24	Tongue Jack Cylinder - Welded
b.	900-3912-12	Tongue Jack Cylinder - Tie Rod
c.	904-0007-14	Pin For Welded Cylinder (Not Shown)
2.	914-1000-38	Lock Pin
3.	980-0131-50	Inside Tube Assembly
4.	980-0509-53	Drop Leg Foot Pad Assembly
5.	900-3925-94	Check Valve
6 a.	900-3920-01	Tongue Jack Valve (SAE O-rings)
b.	900-3901-42	Tongue Jack Valve (Pipe Fittings)
7.	980-0509-00	Hydraulic Tongue Jack Kit (Includes #'s 1 - 6)

NOTE: Parts may not be exactly as shown.

Bandit

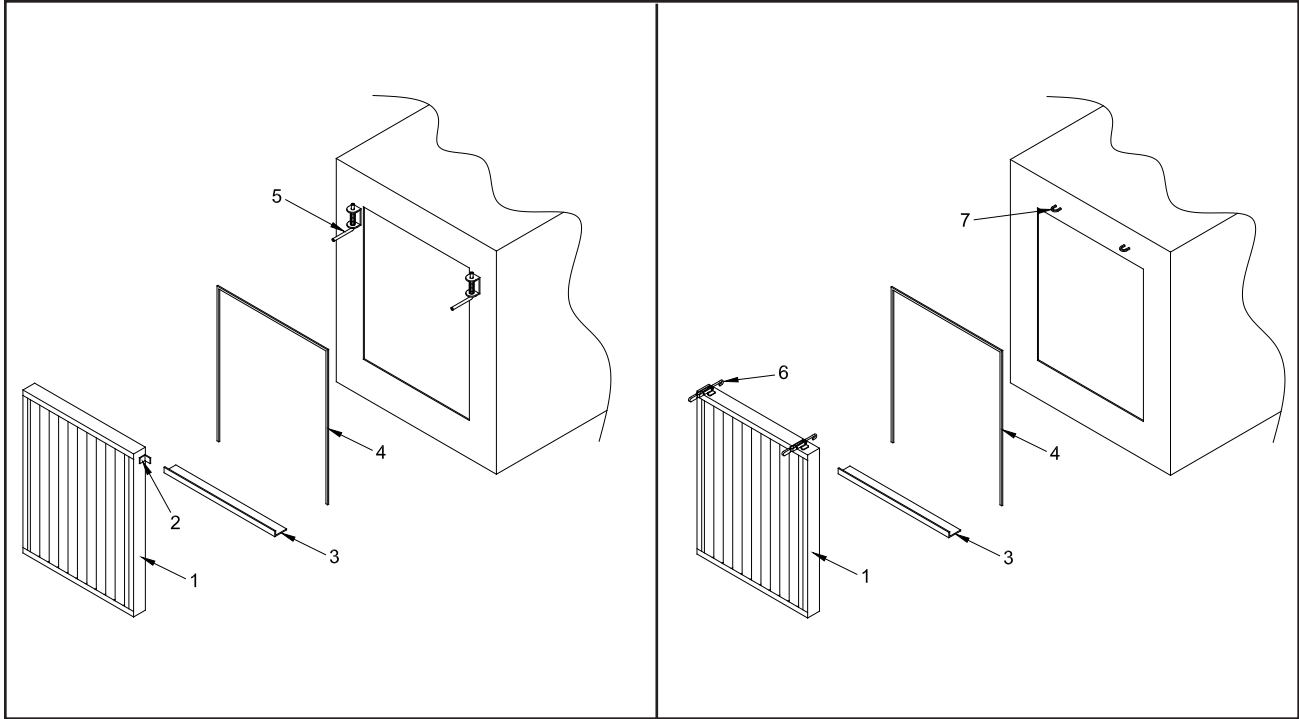

LOCATION	PART NUMBER	DESCRIPTION
1.	980-0508-17	Bandit H.D. Foldaway Radiator Screen Ass'y (specify latch type)
2.	980-0122-86	Spring Lock Tab Foldaway Radiator Screen
3.	*_*	Mount Tray For Foldaway Radiator Screen
4.	900-7900-57	Weather Strip
5 a.	900-4901-83	Spring Lock Plunger
b.	900-7900-93	Rubber Cap For Spring Lock - 1/2" Diameter
6.	900-4901-61	Hook Pull Clamp
7.	980-0128-77	Lock Tab For Hook

***_* Will Vary Depending On Engine And Component Options. Order By Serial Number Of Chipper Or Physical Description.**

NOTE: Parts may not be exactly as shown.

Bandit

MODEL 1590 ARTICULATING TONGUE

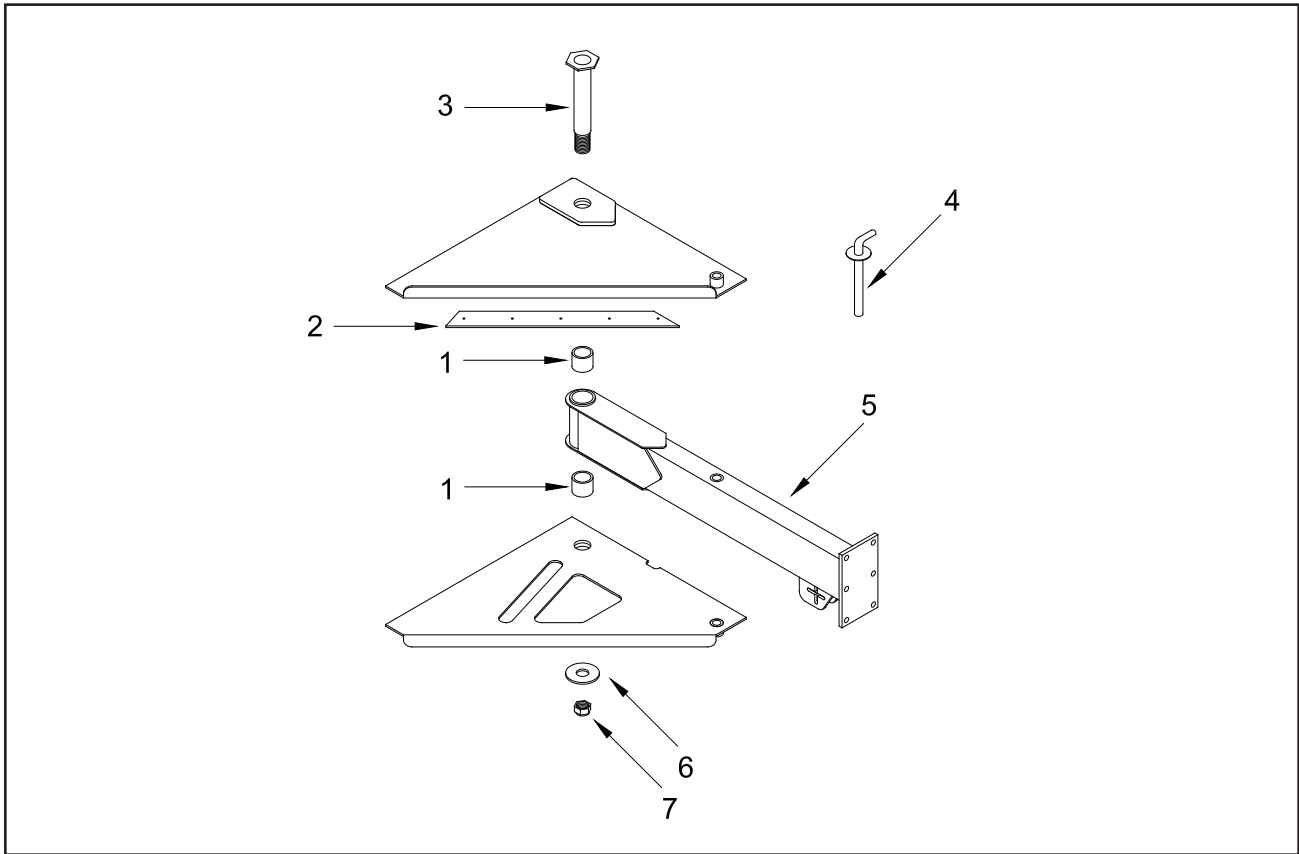

LOCATION	MODEL 1590 PART NUMBER	DESCRIPTION
1.	900-1907-82	Tension Bushing
2.	911-1002-42	Articulating Tongue Plastic Slide
3.	914-1017-16	Articulating Tongue Pivot Pin
4.	980-0500-16	Articulating Tongue Lock Pin
5.	911-0500-40	Articulating Tongue Assembly
6.	900-4905-95	Articulating Tongue Pivot Pin Washer
7.	914-4901-10	Articulating Tongue Pivot Pin Nut
8.	900-3906-27	Articulating Tongue Cylinder (Not Shown)
9 a.	900-3920-01	Articulating Tongue Valve (SAE O-Rings) (Not Shown)
b.	900-3901-42	Articulating Tongue Valve (Pipe Fittings) (Not Shown)

NOTE: Parts may not be exactly as shown.

