

TABLE OF CONTENTS



	PAGES
INTRODUCTION & WARRANTY	2
SERIAL NUMBER LOCATIONS	6
SAFETY PROCEDURES	7
EQUIPMENT SPECIFICATIONS	11
DECALS	12
SUPER SWEEP OPTION	15
CONTROLS	19
MACHINE OPERATION	25
TRANSPORTATION PROCEDURES	28
MAINTENANCE	30
HYDRAULIC SECTION	44
CUTTER WHEEL SECTION	56
ELECTRICAL SECTION	58
LUBRICATION & COOLANT	64
REPLACEMENT PARTS SECTION	65
CUTTERWHEEL COMPONENTS	66
UPPER FRAME COMPONENTS	68
ENGINE MOUNT COMPONENTS	72
BELT ENGAGE COMPONENTS	74
PIVOT BRACKET COMPONENTS	75
FRAME COMPONENTS	76
STEERING COMPONENTS	78
CONTROL BOX COMPONENTS	84
TANK COMPONENTS	85
GRADING BLADE COMPONENTS	86
REMOTE CONTROL COMPONENTS	87
HYDRAULIC COMPONENTS	88
SERVICE RECORD	104

NOTICE

ANY PART, PORTION, DESIGN, NUMBER, SPECIFICATION, AND/OR DIMENSION IN THIS MANUAL IS SUBJECT TO CHANGE WITHOUT NOTICE BY THE MANUFACTURER.

INTRODUCTION

The purpose of this manual is to provide the user with specifications and procedures for the operation, maintenance and repair of this BANDIT product. As with any piece of equipment, safety should always be a constant thought while the machine is being operated, serviced or stored. In order to highlight this consideration, the material which addresses safety is preceded by the following signal words:

Signal Word	Likelihood of Occurrence	Degree of Potential Injury or Damage
 DANGER	Will occur if warning is ignored	Severe
 WARNING	Can occur if warning is ignored	Severe
 CAUTION	Will or can occur if warning is ignored	Minor to Severe
NOTICE	Important, but not hazard related	Minor

The equipment is designed and manufactured in accordance with the latest product industry standards. This alone does not prevent injury. It is the operator's responsibility to use good judgement and follow the warnings and instructions as indicated in this manual, on the machine and follow all safety standards per ANSI and OSHA instructions.

WARNING

Improper use of the product can result in severe personal injury. Personnel using the equipment must be qualified, trained and familiar with the operating procedures as defined in this manual, prior to operating the product.

WARNING

It is the responsibility of the owner or employer to insure that the operator is trained and practices safe operation while using and servicing the machine. It is also the owner's responsibility to provide and follow a regularly scheduled preventative maintenance and repair program on the product, using only factory approved replacement parts. Any unapproved repairs or modifications may not only damage the machine and its performance, but could result in severe personal injury. Unapproved repairs or modifications will void warranty and eliminate manufacturer of any liability claims. Consult the equipment manufacturer!!!

Each machine is shipped with a manual, a customer's check sheet on the product, and any available parts & service manuals on component parts not produced by this manufacturer. Additional copies of these manuals and check sheets can be purchased from the manufacturer, or through the dealer. Engine parts, service and maintenance manuals **MUST** be purchased through the engine manufacturer or their dealer.

NOTICE

The producer of this Bandit product reserves the right to make any modifications or revisions to the design or specifications of its machine without advance notice. The producer also reserves the right to change machine and part prices as needed without advance notice.

BANDIT INDUSTRIES, INC.

EXPLANATION OF LIMITED WARRANTY

The manufacturer will not reimburse the customer or dealer labor costs incurred for installing “bolt-on” or “slip-on” items, such as hydraulic pumps and motors, control valves, flow dividers, belts, sheaves, etc. The manufacturer will provide replacement parts to the customer for defective parts during the warranty period. **Defective parts must be returned to Bandit Industries, Inc.** It will be the customer’s responsibility to install the replacement parts unless arrangements are made with the selling dealer.

The manufacturer will not reimburse travel costs to servicing dealer unless prior approval has been obtained from the manufacturer. It is the customer’s responsibility to deliver the machine to dealer’s service facility, unless other arrangements have been agreed to between selling dealer and customer.

The manufacturer may elect, at its discretion, to reimburse reasonable labor costs to customer or dealer for major defect repairs. Diagnostic labor and overtime labor will not be covered under warranty. Prior approval must be obtained from Bandit Industries, Inc.

There are several forms that must be completely filled out and returned to us in reference to our portion of warranty. Read and understand the Bandit Limited Warranty responsibilities. Some components on your machine are covered by their respective manufacturers and cannot be handled through Bandit Industries as stated in Warranty Section of this manual.

Use this manual to help you resolve what and where your problem is, in most cases you can fix it easily. If you still have problems, work through the dealer you purchased the machine through, or contact Bandit Industries direct if needed.

Make sure the following forms are used, for us as well as you, to keep track of service and pending warranty request. It is our company policy that all parts shipped out will be invoiced until the possible warranty parts are returned with a Warranty Claim Form completed for consideration.

Make sure the Warranty Validation Form is completed and sent in to us as soon as you receive the Bandit. This will activate our warranty responsibilities.

If Warranty Validation Form is not on file, all Warranty consideration is null and void.

NOTICE

Prior to delivery to final owner and during storage, this machine must be serviced and lubricated to avoid damage that will not be covered under warranty, see “Lubrication & Coolant” page.

Also, damage or premature failure of equipment components because of incorrect or incomplete service and maintenance by the equipment owner will not be covered under warranty.

All controls, safety devices, guards, and shields must be correctly operational and securely in place at all times during equipment operation.

Bandit

BANDIT INDUSTRIES, INC. LIMITED WARRANTY (989) 561-2270

Bandit Industries Inc., also referred to as “Manufacturer” warrants this new product to be free of defects in workmanship and material for a period of 1 year.

This warranty takes effect upon delivery to the original retail purchaser. The manufacturer at it's option will replace or repair at a point designated by the manufacturer, any parts which appear to have been defective in material or workmanship. The manufacturer is not responsible for labor, consequential damages, traveling or down time expenses.

This warranty and any possible liability of Bandit Industries Inc., is expressly in lieu of any other warranties, expressed or implied, including but not limited to, any implied warranty or merchantability of fitness for a particular purpose and of any noncontractual liabilities including product liabilities based upon negligence or strict liability. Bandit Industries Inc., will not be liable for consequential damages resulting from breach of warranty.

All parties involved agree that the Owner's Sole and Exclusive Remedy against the Manufacturer, whether in contract or arising out of this warranty, instructions, representations, or defects shall only be for the replacement or repair of defective parts as provided herein. In no event or circumstances shall the Manufacturer's liability exceed the purchase price of the machine. The buyer also agrees that no other remedy (including but not limited to consequential or incidental loss) shall be available to him or her.

It is absolutely necessary to return the Warranty Validation Form, completely and accurately filled out, and notify Bandit Industries Inc., in writing within ten (10) days from the date of purchase to validate this warranty. If Warranty Validation Form is not on file, all Warranty Consideration is NULL AND VOID.

This warranty will not apply if the Bandit product is not operated with replacement parts or equipment not manufactured or recommended by Bandit Industries, Inc.

This warranty will not apply if the Bandit product is not operated in a manner recommended by the manufacturer. The following examples would void the warranty:

1. The completed Warranty Validation Form is not on file.
2. The Bandit product has been abused, or not serviced properly.
3. Repairs or attempted repairs made without prior written authorization.
4. Repairs made due to normal wear are not warrantable.
5. The Bandit product was involved in, or damaged by an accident.
6. The Bandit product was damaged from any type of foreign material.

The owner is responsible for all scheduled maintenance as explained in the Operators Manuals. Negligence of proper maintenance or any other negligence, accident or fire; nor with failure to adjust, tighten, or replace wear items included but not limited to items such as teeth, teeth holders, belts, lubrication fluids, bearings, filters, hydraulic components, loose nuts or bolts, etc. may void warranty.

All components and parts being returned to Bandit Industries for warranty consideration must be complete and assembled when delivered. Hydraulic components and parts must be returned assembled with all fluid ports capped or plugged and free of foreign contamination, or warranty will not be considered.

INTRODUCTION & WARRANTY

BANDIT INDUSTRIES, INC. LIMITED WARRANTY (989) 561-2270

NOTICE This warranty applies only to new and unused equipment or parts thereof manufactured by Bandit Industries Inc. and is void if the machine is operated with replacement parts or equipment not manufactured or recommended by Bandit Industries Inc.

All other components are warranted by their respective manufacturers (i.e. engines, axles, hydraulic pumps and motors, clutches, tires, batteries, etc.) Any machines used for lease or rental purposes warranty is limited to 90 days from the first day of initial service.

NOTICE Clutch maintenance and adjustments and engine maintenance (air filter maintenance, oil changes, oil filter maintenance, etc.) are important to your machine. Refer to the clutch or engine manual for the maintenance schedule. Failure to perform the clutch or engine maintenance will void the warranty with the respective manufacturer, Bandit Industries Inc. does not warranty these components!

CONTINENTAL U.S. INFORMATION PHONE NUMBERS FOR ACCESSORIES (NOT COVERED UNDER PRODUCT WARRANTY PROGRAM)

Briggs & Stratton (Vanguard) Engines	1-414-259-5333	PGL Auto Clutch	1-800-551-2938
Caterpillar Engines (Thru 275Hp)	1-800-551-2938	PT Tech Clutch	1-330-414-3172
Caterpillar Engines (300Hp & Up)	1-866-228-2111	NACD, Rockford Clutch	1-800-383-9204
Continental Engines	1-800-726-8870	Twin Disc Clutch	1-262-638-4000
Cummins Engines	1-248-573-1592	Electronic Solutions	1-866-736-6839
Deutz, Lombardini Engines	1-800-445-5273	I.E.C. (formerly E.S.I.)	1-815-985-0383
Ford, Hatz Engines	1-800-726-8870	L.O.R. MFG.	1-866-644-8622
GM, Perkins Engines	1-800-551-2938	Miratron Inc.	1-866-285-0132
Honda Engines	1-734-453-6258	Omnex Radios	1-419-294-4985
John Deere Engines	1-888-803-9175	Dexter Axles	1-574-295-7888
Kohler Engines	1-800-854-9273	Tires	1-989-463-4088
Kubota Engines	1-800-457-7056	Caterpillar Tracks	1-309-636-1100
Robin Engines	1-248-399-0002	Chermack Tracks	1-715-458-2655
Wisconsin Engines	1-800-726-8870	Petro-Canada Hydrex XV	1-888-284-4572
Interstate Batteries	1-800-331-2000		

(Phone numbers for outside the continental U.S. can be supplied from your phone directory or local Bandit dealer.)

In order to process any warranty claims, it is the owner's responsibility to report the claims promptly to the Manufacturer, or our authorized dealer from whom the equipment was purchased.

It is necessary to include the following information on any and all requests for warranty:

- 1) Warranty Claim Form, obtained from Bandit Industries or it's dealers, completely and accurately filled out.
- 2) Dealer from whom purchased.
- 3) Date of delivery.
- 4) Serial number of unit.
- 5) Model number of unit.
- 6) Engine make and serial number.
- 7) Length of time in use (hours on machine).
- 8) Date of Failure.
- 9) Nature of Failure.

Bandit Industries Inc., reserves the right to alter, improve, revise or modify any parts or products with the altered, improved, revised or modified parts or products. They also may change design, specifications, or part prices without advance notice.

Bandit Industries Inc., is NOT responsible for updating or upgrading completed machines with design changes that are made after it's production.

Bandit Industries Inc., expects the Customer/Owner to bring their machine to the Dealer/Manufacturer for Warranty Repairs. The Manufacturer **DOES NOT** pay Dealers or Customers for bringing their machine in for repair. Nor does the Manufacturer furnish loaner machines while the unit is being repaired.

Bandit

TYPICAL GRINDER SERIAL NUMBER AND/OR WORK ORDER NUMBER LOCATIONS

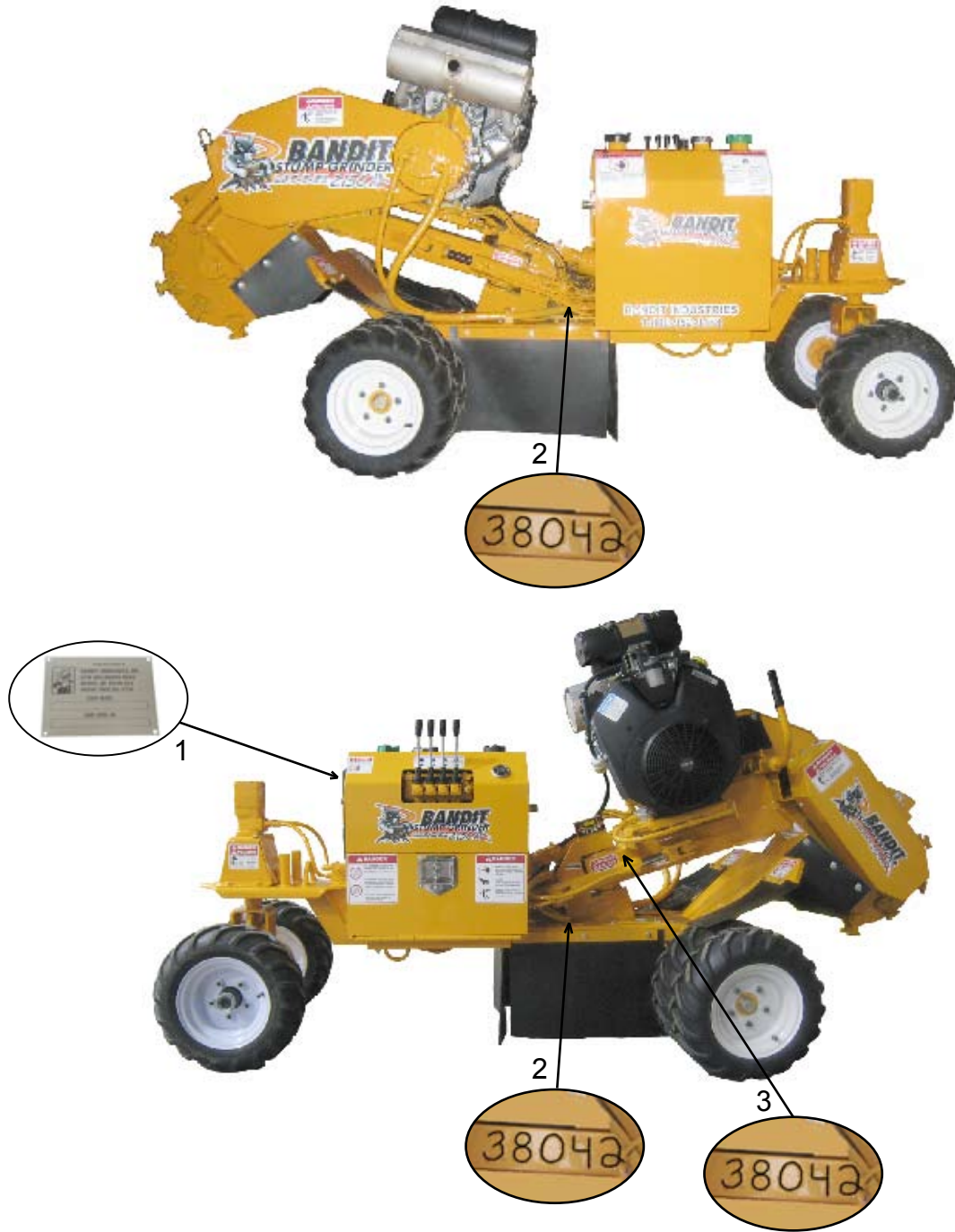



- 1. Serial Number
- 2. Work Order Number welded on top of frame
- 3. Work Order Number welded on side of boom (start 9/09)

NOTICE The engine information is located on the engine block. The clutch information is located on the clutch plate (if equipped).

SAFETY PROCEDURES

DANGER

The words  Danger,  Warning,  Caution, and Notice are used on the safety decals and throughout this manual, to make you aware of the safety procedures. These procedures are very important, read and obey them.

YOUR SAFETY IS VERY IMPORTANT TO US!

This machine is equipped with safety decals, guards and designs for your protection.

Don't ever take the machine for granted, always be cautious and careful when operating your equipment.

Read and follow all the instructions in your manual thoroughly. Your safety is dependent on your knowledge of how to operate and maintain this machine. You may obtain additional copies of this manual from your Bandit Dealer.

Before operating machine, you must have all potential operators; read and understand manuals and decals, watch the video and follow the recommendations.

Regardless of how hard a manufacturer tries to produce a safe machine, accidents still happen. Normally accidents are caused by people making mistakes. They do not read the manual, they ignore warning decals or do not use lockouts provided for their safety. This normally happens after the person has become accustomed to the machinery. In the initial start up and operation of the machinery, they are cautious, they are very careful because they do not understand the machine.

This equipment is intended for use by personnel who are experienced with similar equipment. Always operate safely. There should be at least two qualified and trained operators at the work site. They should be positioned in safe working locations, following safety procedures and instructions, and aware of each others whereabouts. There should, also, be at least two people on site during maintenance and service procedures in case an accident should occur. Never operate any machine while under the influence of drugs or alcohol.

Keep children, bystanders and animals clear of working area. Never operate equipment that is in need of repair or adjustment.

DANGER

Before starting the machine, take a minute to check a few things. The grinder should be in an area restricted from people passing by. This area around the grinder must be free of all objects that can obstruct movement when working with the grinder. The machine should be checked for loose tools or foreign objects, especially in the grinding area. All tools not in use should be secured in a tool box.

WARNING

Operators **must** at all times be located within easy reach of all feed control and shut-off devices when the unit is running. They must be attentive and prepared to activate the devices.

DANGER

Torn or loose clothing is more likely to get caught in moving machinery parts. Keep such items as long hair, shirt sleeves, and shirt tails properly contained. Avoid wearing necklaces, rings, watches, and especially neckties while operating this machinery. Make sure the machine is in excellent condition, and all the guards are in place, tight and secure.

Wear all personal protection equipment and follow all safety standards per ANSI and OSHA instructions. Examples of equipment: hard hat, face shield, safety glasses, gloves, ear protection, etc. Always keep a fully charged fire extinguisher with the machine while operating and servicing the machine.



 **WARNING**



WEAR EYE & PERSONAL PROTECTION EQUIPMENT

Wear all personal protection equipment and follow all safety standards per ANSI and OSHA instructions.

SAFETY PROCEDURES

DANGER

NEVER sit, stand, lay, climb or ride anywhere on this machine while it is running, operating, or in transit. You will be injured.

WARNING

It is very important after you have operated a new machine for approximately an hour to shut down the machine and recheck all hydraulic fittings. Retighten as needed.

DO NOT GO NEAR HYDRAULIC LEAKS! High pressure oil easily punctures skin causing serious injury, gangrene, or death. **DO NOT** use fingers or skin to check for leaks. Lower load or relieve hydraulic pressure before loosening fittings. Use a piece of cardboard to find leaks. Never use your bare hands.

In cold weather situations let your hydraulic system idle for approximately 15 minutes to allow the system to warm up to operating temperature. Avoid burns from fluid. Hot fluid under pressure can cause severe burns. Relieve all pressure in the system before disconnecting the lines, hoses or performing other work. Allow system to cool down to ambient temperature before opening any coolant or hydraulic oil system.

WARNING

It is very important after you have operated a new machine for approximately an hour to shut down the machine and recheck all nuts and bolts. It is normal for nuts and bolts to loosen once on a new piece of machinery. If you tighten them now, there is a good possibility they won't loosen again. Certain nuts and bolts must be checked periodically such as cutter teeth bolts, etc. for torque and fit.

Most of the nuts used on the Bandit Grinder are self locking. After a nut or bolt has been removed five times, it should be replaced to insure proper tightness. This is especially critical on the cutter tooth bolts!

After the engine is started, let the grinder disc turn at the lowest RPM's possible. Listen for any type of noise that is foreign. Any steel on steel noise is foreign. If you hear a noise, stop the engine, find the problem and fix it.

WARNING

DO NOT operate this machine unless all hydraulic control devices operate properly. They must function, shift and position smoothly and accurately at all times. Faulty controls can cause personal injury!

DANGER

Do not go near or in-line with the debris field of the stump grinder while in operation. While grinding stumps, the chips and portions of the stump fly from the cutterhead and can cause severe injury.

DANGER

DO NOT operate this machine indoors! Exhaust fumes can be fatal. Never refuel while the machine is running. Never refuel in the shop or building. Always refuel in a well ventilated area, away from sparks or open flames, **DO NOT SMOKE**. Extinguish all smoking materials. Wipe up all spilled fuel before restarting the engine. Do not fill above 1/2" (12.7 mm) from top of tank.

To obtain the most from your machine, for the least amount of cost, it is a good practice to set up and follow a scheduled preventative maintenance program. It will eliminate many possible problems and down time.

WARNING

Never use jumper cables during freezing temperatures. Haul the machine inside and allow the battery time to warm up. If the machine must be started outside, inspect the battery acid for ice formation. Explosion will occur with a frozen battery. If the machine is going to be operated in excessively cold conditions, a larger cold cranking amp battery may be needed to insure proper and prompt starting. Never use jumper cables in a confined or unventilated area. Battery acid fumes are explosive. Battery acid can cause severe burns. Never expose an open flame or spark near the battery. Keep all burning materials away from the battery. When servicing the battery, shield eyes and face, and do not smoke. Service in a well ventilated area.

DANGER

Before attempting any type of maintenance disengage clutch, turn off engine, wait for the cutter wheel to come to a complete stop, install the cutter wheel lock pin, disconnect battery, and make sure the ignition key is in your possession.

ALWAYS install the lock pin into the cutter lock tube before working on the grinder.

Simply slide the lock pin into the cutter wheel lock tube. This is to insure that the cutter wheel cannot be started while you are working on the grinder. If for some reason the cutter wheel would start to turn, it would simply hit the lock pin.

Bandit

SAFETY PROCEDURES

NOTICE

Do not attempt to start the engine or engage the engine PTO (power-take-off) system on this machine if the cutter wheel is jammed or frozen in place. If you do, you will damage or ruin the drive belts and/or the PTO which will not be covered under warranty and will cost you down time and money.

DANGER

Your machine may or may not be equipped with a clutch. Depending on the options ordered, some machines are direct drive.

Do not work on the machine if the engine is running with the clutch disengaged. A clutch can self engage if either the pilot or throw-out bearing happens to seize to the main output shaft.

There are various types of clutches (PTO's) available for this type of equipment. Make sure to study the original clutch manufacturer's manual that is provided with the machine and follow its instructions for operation, service, and adjustments. Some styles require clutch engagement to be maintained so that it takes a lot of force, others will require very little force, and some are push button, electric, manual lever, or hydraulic activation. Each different style clutch (PTO) is a very expensive item that will fail if not correctly maintained and adjusted. It will be quite costly if a few minutes are not taken daily, weekly, and monthly to keep the clutch serviced as required.

The operator must take care in the engagement and disengagement of the clutch, engine RPM should always be below 1000 RPM. When the engine has sufficiently warmed up, bump the clutch handle against engagement to start the cutter wheel turning. This will have to be repeated until the cutter wheel is turning at proper ratio with engine RPM. Then push the handle all the way in gear until it locks into position securely. After engagement raise engine RPM to full throttle. Engaging and disengaging the clutch at high engine RPM will quickly and excessively wear out clutch plates as well as bearings. Refer to clutch manufacturer's manual for proper service and operation.

DANGER

Never grind any materials that might contain wires, stones, nails, or other metal objects which may damage the teeth and become dangerous projectiles. Remove all rocks and stones from stump grinding area.

DANGER

Avoid moving parts. Keep hands, feet, and clothing away from power driven parts. Keep all guards and shields in place and properly secured.

DANGER

Do Not start to grind a stump unless you are completely sure there are not any power lines, water lines, sewer lines, phone lines, etc. in the area above or below ground level where you are grinding.

DANGER

Never go near cutter wheel or teeth while engine is running or cutter wheel is coasting to a stop.

DANGER

Keep the machine in good condition. Be sure the machine is in good operating condition and that all safety devices, including guards and shields are installed and functioning properly. Visually inspect the machine daily before starting the machine. Refer to the "Daily Start Up & Maintenance". Make no modifications to your equipment unless specifically recommended or requested by Bandit Industries Inc.

WARNING

Check laws and regulations. Know and obey all federal, state, and local laws and regulations that apply to your work situation and the transportation of a machine this size.

DANGER

- 

• Use **EXTREME CAUTION** when traveling over non-level surface! Not designed to be used on non-level surface.
- 

• This machine can tip over or tip backwards on non-level surface. You will cause engine damage, machine damage and possible personal injury!
- Use caution when transporting to avoid a roll over because of narrow wheel base!

CALIFORNIA

Proposition 65 Warning

Diesel engine exhaust and some of its constituents are known to the State of California to cause cancer, birth defects, and other reproductive harm.

SAFETY PROCEDURES

IF MACHINE IS EQUIPPED WITH A SELF PROPELLED UNDERCARRIAGE

Machines equipped with undercarriage tracks are shipped with a manual from the track manufacturer. Refer to it for service, operation, and safety information.

⚠ WARNING

Do not attempt to operate the machine on an ascending or descending slope of more than 25° or 46% or a side slope of more than 17° or 30%, it is Dangerous and could be Fatal. This is the maximum slope grade the machine can be operated on if the hydraulics, self propelled undercarriage, and engine are running at maximum performance and good traction is sustained.

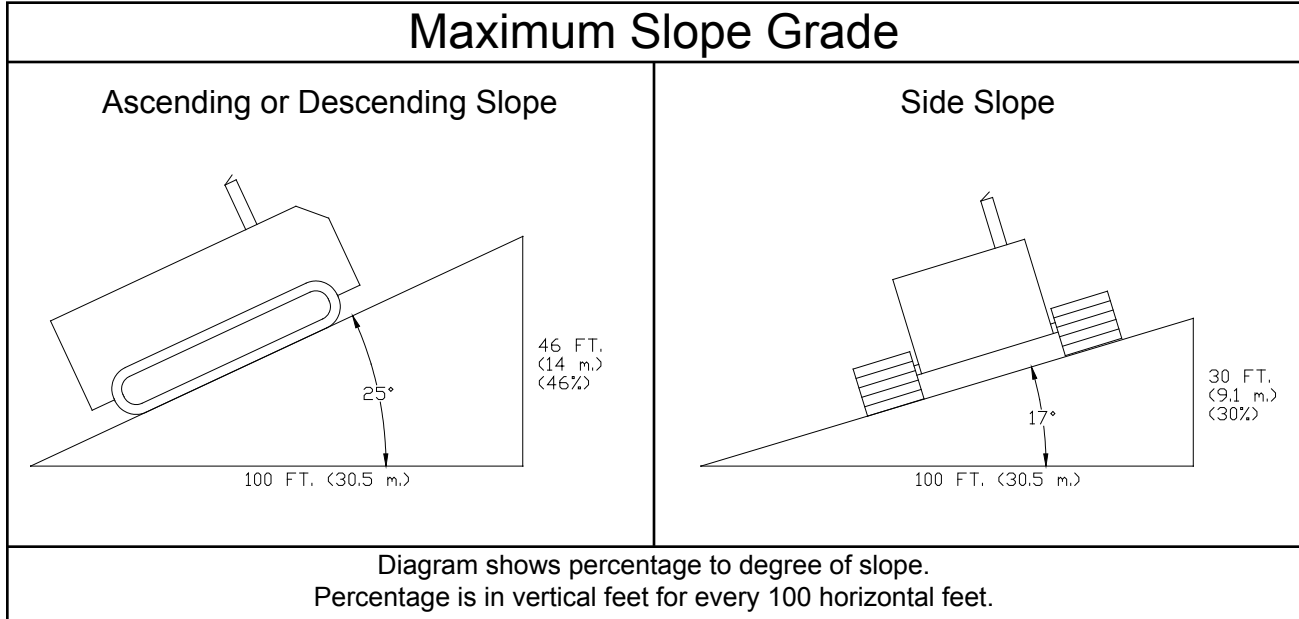

⚠ WARNING

Any increase from the specified maximum operating angles may cause loss of lubrication function and damage the engine.

⚠ DANGER

The machine should never be parked on a slope at any time. The machine can coast or creep causing equipment and/or personal injury.

⚠ DANGER

Make sure everyone is clear of machine before moving the machine. Stay clear of undercarriage travel system when the machine is moving.

⚠ DANGER

DO NOT entangle feet or hands in undercarriage travel system.

⚠ DANGER

Use **EXTREME CAUTION** when traveling over non-level surface! This machine can tip over or tip backwards on non-level surface. You will cause engine damage, machine damage and possible personal injury!

⚠ DANGER

NEVER sit, stand, lay, climb or ride anywhere on this machine while it is running, operating, or in transit. You will be injured.

Bandit

EQUIPMENT SPECIFICATIONS

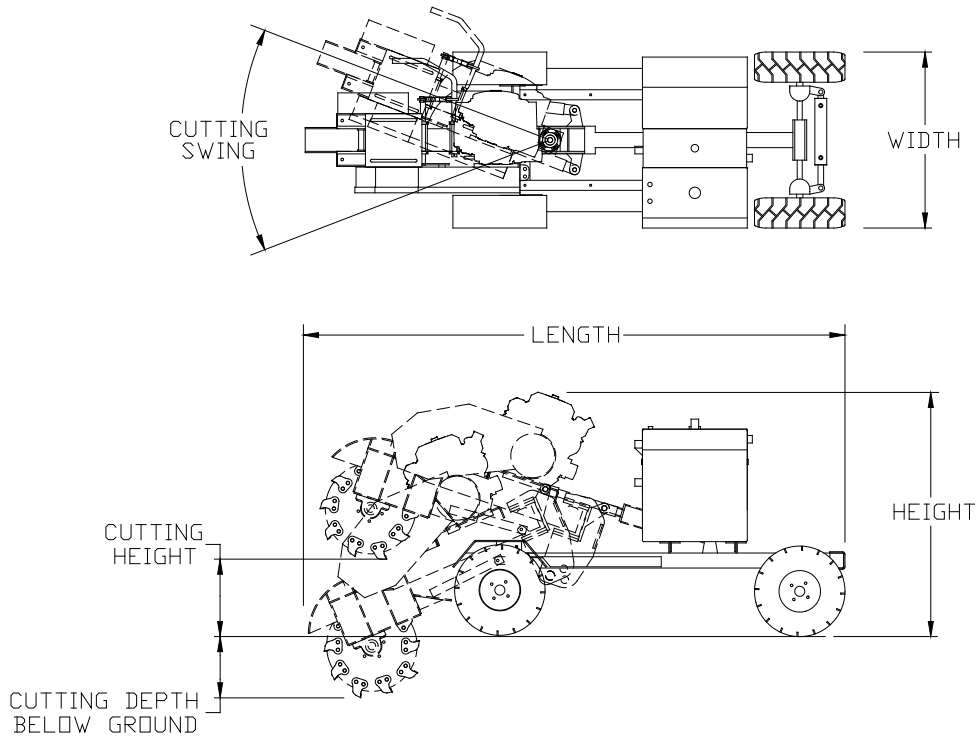

Approximate Dimensions & Weights

(Dimensions & weights will vary depending on optional equipment)

Approx. Model 2150XP: 1650 to 1850 lbs. (748 to 839 kg)
 Weight: Model 2450XP: 1900 to 2000 lbs. (862 to 907 kg)

(Approximate weights depending on engine and equipment options.)

Overall

Dimension: Height: 48" (1.2 m), Length: 112" (2.8 m), Width: 35" (.9 m) or optional 29" (.7 m)

Cutting Depth: 12 1/2" (.3 m)

Cutting Height: 23" (.6 m)

Cutting Swing: 50" (1.3 m)

Number of Teeth
 on Cutter Wheel: 18

Cutter Wheel
 Diameter with Teeth: 21" (.5 m)

Fuel Tank Capacity: 8 1/2 Gallons (32 Liters)

Hydraulic Tank Capacity: 8 1/2 Gallons (32 Liters)

(Approximate dimension depending on equipment options.)

DECAL LOCATIONS

Decal locations may vary, these are general locations.

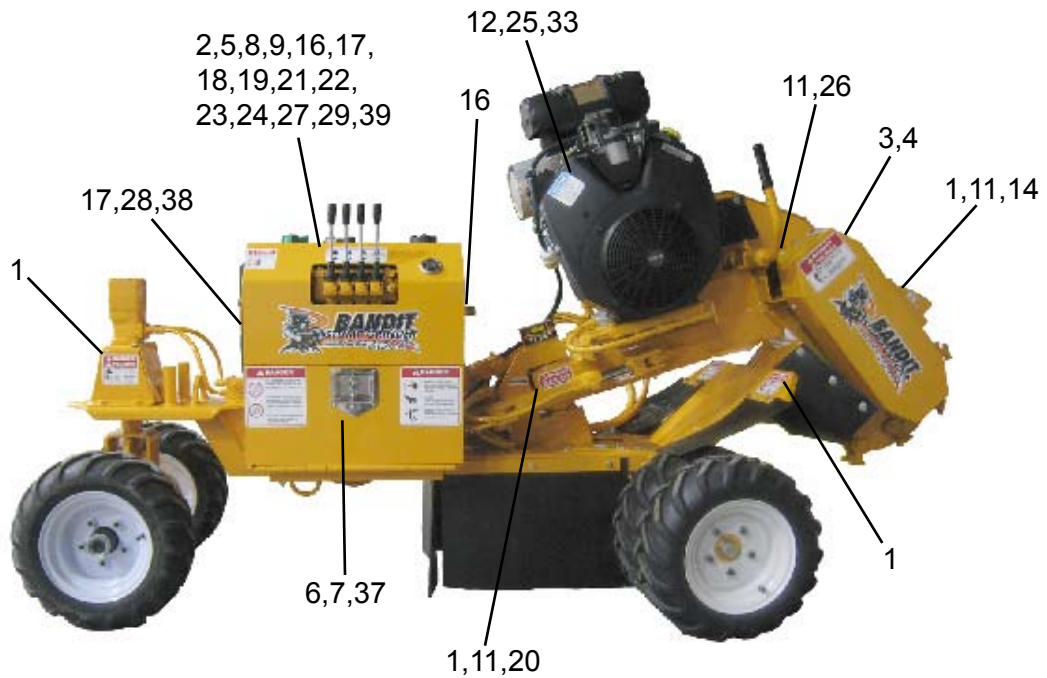
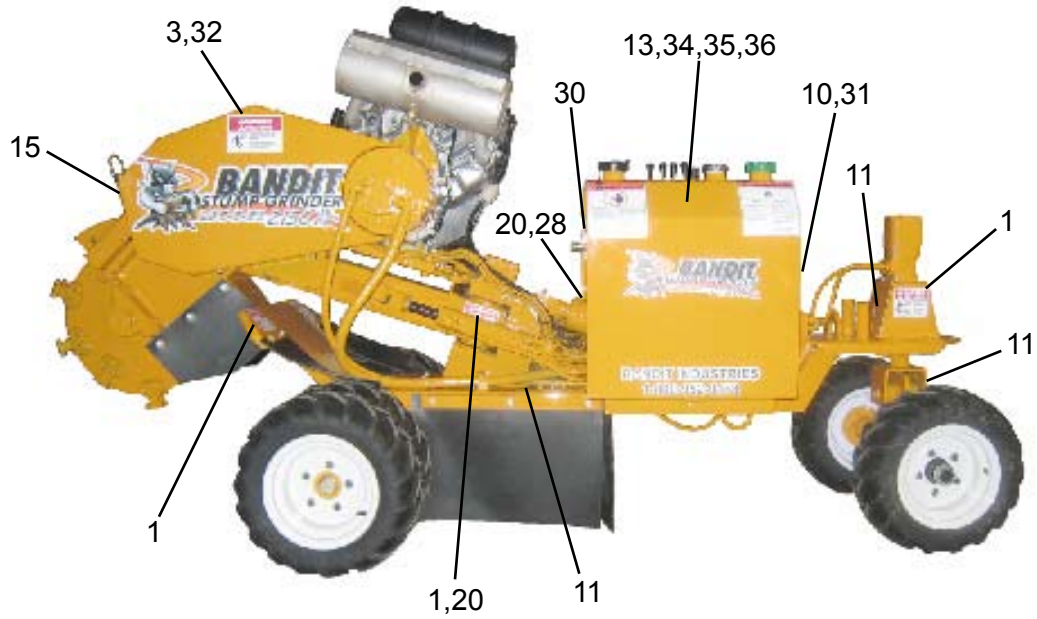

DECAL LOCATIONS

Modifications and/or additions of decals to this list will happen.
 Consult machine dealer or manufacturer for most current decal package.

LOCATION	NUMBER	DESCRIPTION
1.	SPD-02	Moving Parts Keep Hands...
2.	SPD-19	...Minimum 10 Feet Away From Tracks...
3.	SPD-20	Flying Objects Stand Clear...
4.	SPD-28	Do Not Insert Fingers...
5.	SPD-30	Do Not Sit, Stand, Lay, Climb or...
6.	SPD-35	Extreme Caution...Non-Level Surface...
7.	SPD-36	...Debris Field...
8.	SPD-38	Do Not Entangle Feet...
9.	SPD-39	Do Not Operate...
10.	ID-42	Bandit Industries, Inc...USA
11.	INST-12	Grease Daily
12.	INST-44	Proposition 65
13.	INST-53	Hydraulic Oil...Hydrex XV...
14.	INST-73	Cutter Head Lock Hole
15.	INST-74	Cutter Head Lock Pin
16.	INST-79	Swing Speed - Counter-Clockwise To Slow
17.	INST-80	Travel Speed - Counter-Clockwise To Slow
18.	INST-81	Swing Speed - Clockwise To Slow (Remote Machines)
19.	INST-82	Travel Speed - Clockwise To Slow (Remote Machines)
20.	INST-86	Grease Daily - Double Arrow
21.	INST-88	Controls - 4 Function
22.	INST-89	Controls - 5 Function
23.	INST-136	Remote Starting Procedure
24.	INST-137	Remote / Tether
25.	INST-101	Canada Engine Decal
26.	INST-115	Belt Tightening Instructions...
27.	INST-151	Brake Release Procedure
28.	INST-152	Turn Ball Valve...To Release Brakes
29.	INST-153	Brake Release Hand Pump
30.	N-02	Maintain Lubrication...
31.	SPN-06	Decal Maintenance..
32.	N-24	Service Under Beltshield...
33.	N-33	Engine Oil Lubrication...Break-In...
34.	SPW-01	Do Not Go Near Oil Leaks...
35.	SPW-02	Combustible Liquid...Diesel Fuel Only...
36.	SPW-03	Flammable Liquid...Gasoline Fuel Only...
37.	SPW-04	Frozen Battery Will Explode...
38.	SPW-08	Wear Eye & Personal Protection...
39.	SPW-09	...Go Slow Around Corners...
40.	900-8900-34	Basic Safety Decal Kit (Options may require additional decals)
41.	900-8900-66	Bandit Model 2150XP Logo Decal Kit
42.	900-8900-67	Bandit Model 2450XP Logo Decal Kit

NOTICE

Some decals are for optional equipment. Decal locations may vary, these are general locations. If any decals become damaged, replace immediately.

DECALS

Decals located on your Bandit equipment contain useful information to assist you in operating your equipment safely. Some of the decals on your machine and their location are shown in this section.

It is very important that all decals remain in place and in good condition on your machine. Please follow the care and instructions given below:

- 1) You should use soap and water to keep your decals clean. Never use mineral spirits or any other abrasive cleaners.
- 2) Replace immediately any missing or damaged decals. The location the decal is going to be applied to must be clean and dry, and at least 40°F (5°C) before applying decal.
- 3) When the need arises to replace a machine component with a decal attached, be sure and replace the decal.
- 4) Replacement decals are available, and can be purchased from the manufacturer or your Bandit Dealer.
- 5) Combination English / Spanish decals are typically standard. Other foreign language decals are available and may be purchased. Mail translated decals required to Bandit Industries, Inc.

EXAMPLES:



OPTIONAL SUPER SWEEP

Consult the original manufacturer's manual for your machines
Super Sweep operating and maintenance procedures

When grinding material with the machine, the Super Sweep system will automatically stop when the engine drops below a preset RPM point. The engine is constantly being monitored by an adjustable electronic speed switch. The switch can be adjusted so that at a given RPM, an electronic relay system will operate the hydraulic solenoid valves to stop the cutter wheel swing and reverse the swing for a set period of time until the engine has recovered speed.

Due to required components and equipment options a machine may have various types or brands of super sweep systems. Each stump grinder is shipped with the original manufacturer's manual for the super sweep system it is equipped with.

For the approximate super sweep settings on all optional super sweep systems refer to page 18 of the stump grinder manual. For part numbers on the hydraulic portion of the super sweep systems refer to page 103 of the stump grinder manual.

Do not power wash the digital tach hour meters. Pressure causes unwarranted damage. **Do not spray tach, this will void warranty.**

PART NUMBERS FOR AUTOFEED DIGITAL TACH HOUR METERS

IEC (formerly ESI Intelli-Feed)
 Part Number: 900-2908-11
 For Service Call
 1-815-985-0383



Electronic Solutions
 Part Number: 900-2904-85
 For Service Call
 1-866-736-6839



No longer used.

L.O.R. MFG.
 Part Number: 900-2906-82L
 For Service Call
 1-866-644-8622



Miratron Inc.
 Part Number: 900-2910-68
 For Service Call
 1-866-285-0132



No longer used.

SUPER SWEEP TERMINOLOGY

- PPR** Pulses per revolution. On magnetic pick-up machines, this setting will be the number of teeth on the gear or sprocket it is reading. On alternator pick-up machines, the setting will need to be obtained from your local dealer or Bandit Industries.

- Mag Pick-up** Magnetic pick-up, also called pick-up probe. This is normally located screwed into the flywheel housing on the engine block or the pump mount bolted on the engine. See Figure 1.

- Dual Coil Reverse Valve** The dual coil reverse valve can be recognized by a valve with two solenoids bolted on a square block. The solenoid is approximately 2-1/2" (63.5mm) diameter x 2-3/4" (69.9mm) long. It will have two wires coming from it or on the newer machines it will have a connector with a light screwed to it. The swing coil must have power (indicated by the light in the connector) for the cylinders to swing the cutterhead. See Figure 2.

- Solenoid** Electronically activated to produce a magnetic pull which shifts the spool inside the hydraulic valve. Shifting of the spool changes oil flow direction in the swing cylinders.

- High** High or HI is the setting when the cutter head swing will turn back on (grinding operation).

- Low** Low or LO is the setting when the super sweep system will stop and reverse the cutter head swing.

- Back** Amount of time in seconds the cutterhead will back away from the stump. Normally this will be set at .5 seconds.

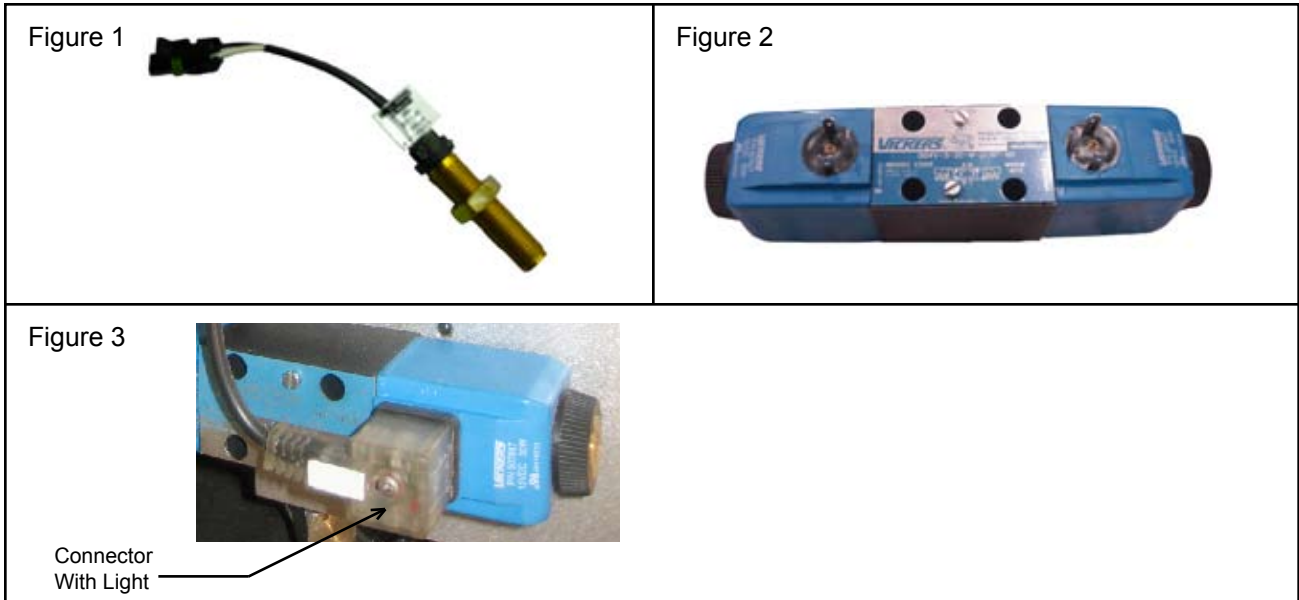

TROUBLE SHOOTING GUIDE

PROBLEM	POSSIBLE CAUSE	SOLUTION
No Display	-Gauge not getting power.	-Check continuity of Red wire to a clean power source. -Check 7.5 amp fuse. -Check connection at engine disable plug at hood pin. -Check key switch for switched power in and out.
	-Gauge not properly grounded.	-Check continuity of Black wire to ground connection.
	-Dead Battery.	-Charge or replace.
Cutter Head Does Not Stop (Super Sweep Doesn't Activate)	-No power to reverse valve solenoid.	-Check fuse on reverse valve signal wire (if equipped). -Check continuity on the reverse valve wire (normally green wire).
	-Faulty tach.	-Check super sweep tachometer settings.
	-Low or "LO" setting wrong.	-Check super sweep tachometer settings.
Cutter Head Swing Does Not Re-engage	-Engine RPM not reaching HI set point on tach.	-Check for stretched or out of adjustment throttle cable. This would not let engine reach full RPM. -Check HI RPM setting on gauge to make sure it is not set too close to full RPM of engine. HI setting should be 150 to 200 RPM below full engine RPM.
	-System pressure.	-Check and readjust per manual specifications.
	-Faulty tach.	-Consult local dealer or Bandit Industries.
Cutter Head Will Not Swing	-No power to reverse valve solenoid.	-Check fuse on reverse valve signal wire (if equipped). -Check continuity on the reverse valve wire (normally green wire).
	-No voltage signal to receiver from tach on electric valves.	-Check for voltage on wire from tach to receiver (normally red, white, yellow wire).
No Signal	-Engine not running.	-Normal operating condition.
	-Bad signal wire.	-Check continuity on the signal wire (white wire in super sweep harness).
	-No signal from alternator.	-Check for at least 3.5 VAC output at idle and 10-12 VAC at HI RPM.
	-No signal from mag pick-up.	-Check for approx. 2-7 VAC at idle and approx. 14-20 VAC at HI RPM. Testing must be done at the two wires coming out of mag pick-up after disconnecting. Remove and clean off magnet at end. Reinstall by turning it in until it bottoms out. Then back off approx. 1/2 a turn. Lock with jam nut.
	-Bad mag pick-up.	-Replace mag pick-up.
Gauge Jumped Program	-Shorts in wire harness.	-Check for possible worn wires or loose connections.
	-Faulty ground.	-Check black wire for a good ground.
	-Faulty tach.	-Consult local dealer or Bandit Industries.
Cutter Head Swing Is Reverse From Normal	-Backup time set wrong.	-Reset backup time. Normal setting is .5 seconds.
	-Sticking reverse valve.	-Check solenoid operation. -Override cartridge manually by sticking a small allen wrench in the end of the solenoid. -Replace solenoid and/or cartridge.
	-Type settings programmed wrong.	-Reprogram or consult local dealer or Bandit Ind.

TROUBLE SHOOTING GUIDE cont.

NOTICE Super sweeps with dual output block will need a jumper plug. This can be a good test to determine if you problem is hydraulic or electronic.

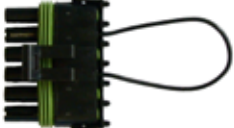
<p>LOR Jumper Plug Part No.: 900-2913-51</p> 	<p>IEC Jumper Plug Part No.: 900-2914-09</p> 
--	--

**APPROXIMATE DIGITAL AUTOFEED SETTINGS
(FOR ALL SUPER SWEEP SYSTEMS - REFERENCE ONLY)**

NOTICE Refer to the Completion/Check Sheet, that is shipped with the machine for the correct engine rpm. If needed, contact your local dealer or Bandit Industries.

Some Current Engine Types	Maximum RPM	PPR	Off RPM	On RPM	Back Up Time
Briggs & Stratton (Vanguard) - 35 Hp	3600	100	3300	3650	.5
Caterpillar C1.5 - 34 Hp	2800	109	2700	2400	.5
Kohler CH740-01 - 27 Hp	3400	6	3250	2600	.5
Kohler CH930S - 38 Hp	3600	6	3300	2650	.5
Kubota V1505 - 35 Hp	3000	10	2600	2450	.5
Kubota V1505T - 44 Hp	3000	10	2600	2450	.5



Basic Location of Controls and Adjustments

LOCATION SHOWN

- | | |
|---|-------------------------------|
| 1. Drive Belts | 11. Belt Engage Handle |
| 2. Cutter Wheel Lock Pin | 12. Cutter Wheel Belt |
| 3. Cutter Wheel Lock Pin Hole | 13. Holding Stake (not shown) |
| 4. Cutter Wheel Teeth | |
| 5. Travel Speed | |
| 6. Swing Speed | |
| 7. Manual Controls | |
| 8. Hour Meter, Tachometer, Super Sweep Tachometer | |
| 9. Tilt Indicator | |
| 10. Engine Throttle (varies with engines) | |

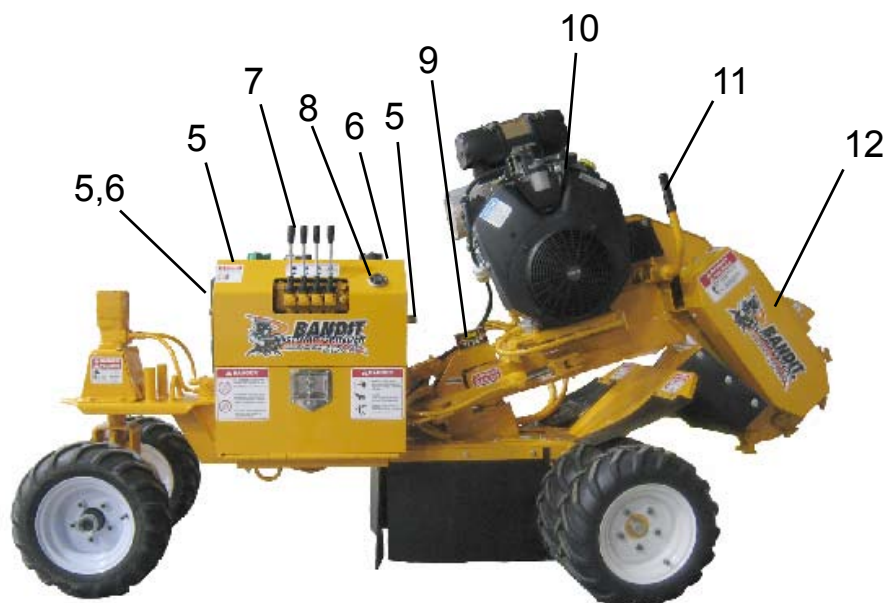

MANUAL CONTROLS

Basic Location of Controls and Adjustments

LOCATION SHOWN

- | | |
|---|----------------------------|
| 1. Swing Speed Control | 10. Travel Speed Control |
| 2. Brake Release Ball Valve (Pre 6/09) | 11. Remote / Tether Switch |
| 3. Brake Release Needle Valve (Start 6/09) | 12. Tether Plug Jack |
| 4. Steer Right / Left | |
| 5. Drive Forward / Reverse | |
| 6. Cutter Down / Up | |
| 7. Tongue Out / In or Blade Up / Down | |
| 8. Swing Left / Right | |
| 9. Hour Meter, Tachometer, Super Sweep Tachometer | |

Manual Machines

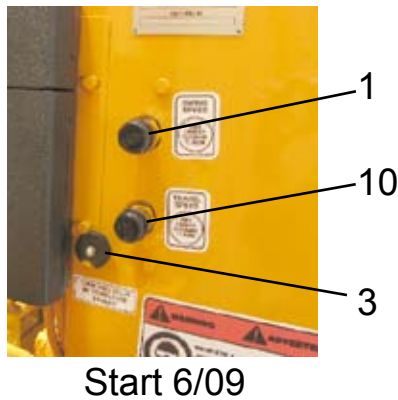

Remote Machines

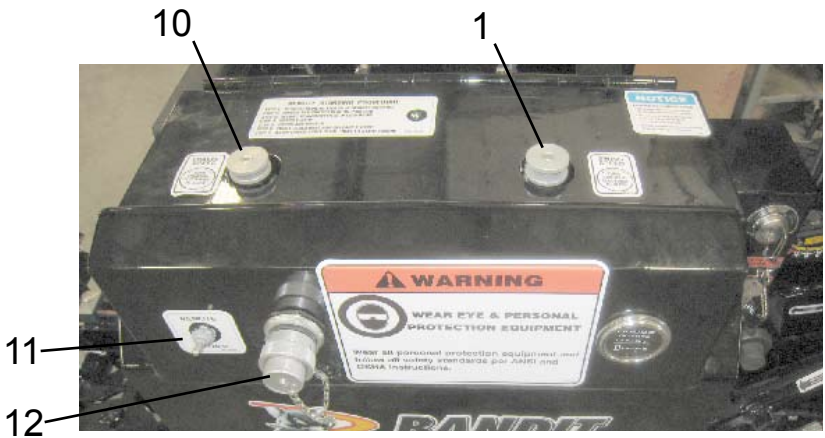

MANUAL CONTROL OPERATING PROCEDURES

1. Swing Speed Control:

The swing speed controls the rate the cutter wheel passes through the stump. To increase or decrease the swing speed, the control knob will have to be turned clockwise or counter-clockwise depending on the options on that particular machine.

2. Brake Release Ball Valve (Pre 6/09):

Turned 90° when moving the machine without power.

3. Brake Release Needle Valve (Start 6/09):

Turn 3 to 4 full revolutions when moving the machine without power.

4. Steer Right / Left:

To steer the machine to the right, push the handle or switch, away from the operator. To steer the machine to the left, pull the handle or switch, towards the operator. The steering is stationary when the handle or switch is in the center location.

5. Drive Forward / Reverse:

To move the machine forward, push the handle or switch away from the operator. To reverse the machine, pull the handle or switch towards the operator. The machine is stationary when the handle or switch is in the center location.

6. Cutter Down / Up:

To lower the cutter wheel, push the handle or switch away from the operator. To lift the cutter wheel, pull the handle or switch towards the operator. The cutter wheel lift is stationary when the handle or switch is in the center location.

7. Tongue Out / In or Blade Up / Down (optional):

To extend the tongue out or lift the grading blade, push the handle or switch away from the operator. To retract the tongue in or lower the grading blade, pull the handle or switch towards the operator. The tongue or grading blade is stationary when the handle or switch is in the center location.

8. Swing Left / Right:

To swing the cutter wheel to the left, push the handle or switch, away from the operator. To swing the cutter wheel to the right, pull the handle or switch, towards the operator. The swing is stationary when the handle or switch is in the center location.

9. Hour Meter, Tachometer, Super Sweep Tachometer:

Depending on options, may display the engine hours, the engine rpm's and hours, or the engine rpm's, hours, and control the super sweep valve.

10. Travel Speed Control:

Controls the rate the machine approaches the stump. To increase or decrease the travel speed, the control knob will have to be turned clockwise or counter-clockwise depending on the options on that particular machine.

11. Remote / Tether Switch:

On remote control machines, if the toggle switch is in the remote position, the machine is controlled by the transmitter. If the toggle switch is in the tether position and the tether cord is plugged into the jack, the machine is controlled by the tether.

12. Tether Plug Jack:

Plug the tether control cord in here to control the machine if the batteries in your remote control run out of power.

RADIO CONTROLS

Basic Location of Controls and Adjustments

LOCATION SHOWN

- | | |
|---------------------------------------|---------------------------|
| 1. Lift Down / Up | 6. Steer Right / Left |
| 2. Tongue Out / In or Blade Up / Down | 7. Cutter Bump Adjustment |
| 3. Swing Left / Right | 8. Link Light |
| 4. Drive Forward / Reverse | 9. Batteries |
| 5. Engine Stop | |

Tether Control

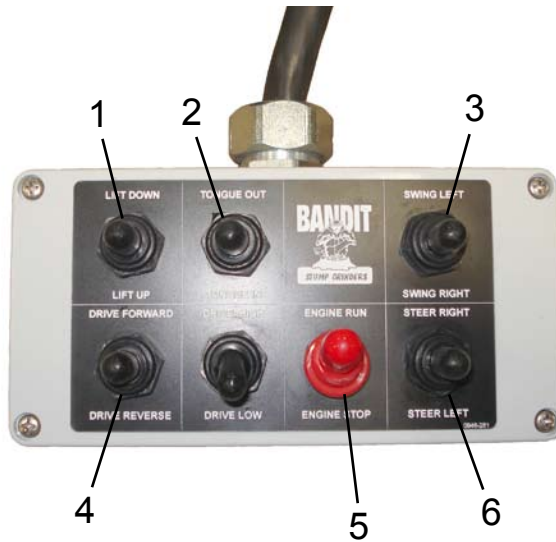

Omnex Transmitter

NOTICE

To turn the transmitter power on:

1. Press the engine stop switch.
2. Toggle any switch.
3. Twist and release the engine stop switch.

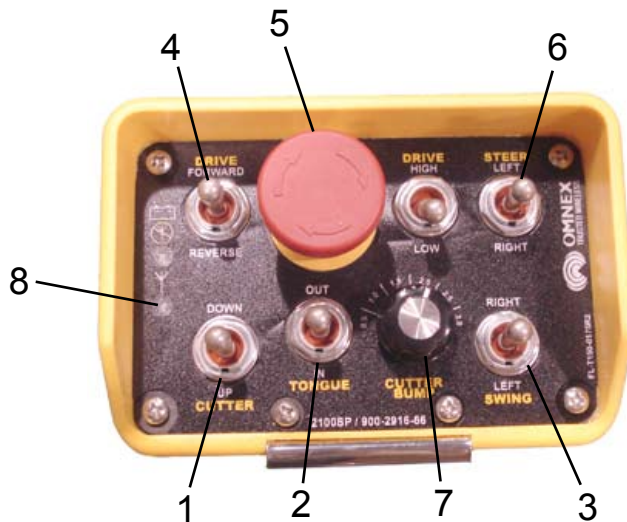

RADIO CONTROL OPERATING PROCEDURES

1. Lift Down / Up:

To lower the cutter wheel, push the switch away from the operator. To lift the cutter wheel, pull the switch towards the operator. The cutter wheel lift is stationary when the switch is in the center location.

2. Tongue Out / In or Blade Up / Down (Optional):

If equipped, to extend the tongue out or lift the grading blade, push the switch away from the operator. To retract the tongue in or lower the grading blade, pull the switch towards the operator. The tongue or grading blade is stationary when the switch is in the center location.

3. Swing Left / Right:

With the tether control or a LOR transmitter, to swing the cutter wheel to the left, push the switch, away from the operator. To swing the cutter wheel to the right, pull the switch, towards the operator. The swing is stationary when the switch is in the center location.

With an Omnex transmitter, to swing the cutter wheel to the right, push the switch, away from the operator. To swing the cutter wheel to the left, pull the switch, towards the operator. The swing is stationary when the switch is in the center location.

4. Drive Forward / Reverse:

To move the machine forward, push the switch away from the operator. To reverse the machine, pull the switch towards the operator. The machine is stationary when the switch is in the center location.

5. Engine Stop Switch:

Shuts off the power to the engine and to the hydraulic valve. The engine stop switch must be pulled out or in the run position for the engine to start.

6. Steer Right / Left:

With the tether control or a LOR transmitter, to steer the machine to the left, push the switch, away from the operator. To steer the machine to the right, pull the switch, towards the operator. The steering is stationary when the switch is in the center location.

With an Omnex transmitter, to steer the machine to the right, push the switch, away from the operator. To steer the machine to the left, pull the switch, towards the operator. The steering is stationary when the switch is in the center location.

7. Cutter Bump Adjustment:

Turn the knob clockwise to increase the distance the cutter wheel drops when you activate the cutter wheel lift control and counter-clockwise to decrease the cutter wheel drops.

8. Link Light:

A yellow light will be flashing when the transmitter is successfully linked to the receiver.

9. Batteries (not shown):

Omnex transmitters require (4) AA batteries (if the batteries are dead, the engine will shut down).

CONSULT THE ENGINE MANUFACTURER’S MANUAL FOR SPECIFIC CONTROLS, OPERATION, & MAINTENANCE FOR TYPICAL ENGINES

- 1) **Ignition Switch:**
Turn the ignition switch key clockwise one stop (on position) to turn the electrical system on. The key should remain in the on position while the engine is running. Turn the key fully clockwise (start position) this will start the engine. To shut off the engine, return the key to the off position.
- 2) **On/Off Switch - Push Button Start:**
Some gasoline engines may have a Toggle Switch or an On/Off Switch combined with a push button to start the engine. First turn the On/Off Switch or Toggle Switch to the on position, then depress and hold the Push Button Start until the engine starts, then release the button. To shut off the engine, return the On/Off Switch or Toggle Switch to the off position.
- 3) **Ignition Switch With Preheat:**
The typical diesel engine may have a preheat system to assist in starting the engine during cold weather. To activate the preheat system, continue to hold the ignition key in the preheat position for 15 to 20 seconds, then attempt to start the engine. If the engine fails to start within 15 seconds, return the key to the preheat position, hold 10 seconds, and try starting again.
- 4) **Choke Adjustment (if equipped):**
Some gasoline engines may have a choke adjustment, pull the choke lever out to choke the engine. Push the choke lever in for normal engine operations.
- 5) **Throttle Adjustment (if equipped):**
Some engines may have a knob or a handle for the throttle adjustment. Typically you would pull the knob out, or turn the handle to increase the engine R.P.M.'s. To decrease you would push in the knob or turn the handle the opposite way.
- 6) **“Bandit” Lever Lock Cable Throttle System (if equipped):**
The Bandit throttle system has (2) positions, HIGH and LOW. Engine R.P.M. is controlled by moving the lever from one position to the other.
- 8) **Push Button Or Electric Throttle System (if equipped):**
Some engines may have a push button or electric throttle adjustment. Engine R.P.M. is controlled by pushing a button or switch to raise or lower the R.P.M.
- 9) **Alternator Warning Light:**
This light will glow when the alternator is not charging, or when the ignition switch is turned on and the engine is not running.
- 10) **Oil Pressure Warning Light:**
This light will glow when the oil pressure is to low, or when the ignition switch is turned on and the engine is not running.
- 11) **Engine Temperature Warning Light:**
This light will glow when the engine, or engine coolant, is above normal operating temperature. If this occurs allow the engine temperature to cool down. If the engine is overheating because of a loss of coolant, or a broken fan belt, shut the engine off immediately.

NOTICE

Most engines have an automatic low oil pressure shutdown device, but some engines do not for example the **Lombardini 9LD**. Expensive damage to the engine may occur if the engine oil level and condition is not checked daily. Follow all maintenance procedures specified by the engine manufacturer’s manual. Check the fuel level daily, running out and repriming is time consuming. Do not over fill the fuel tank, there must be expansion space in the top of the tank. Inspect hoses, fittings, lines, tanks, etc. for any oil, fuel, engine coolant, etc. leaks daily. Repair or replace any damaged or leaking components.

TYPICAL DIESEL ENGINES

TYPICAL GASOLINE ENGINE

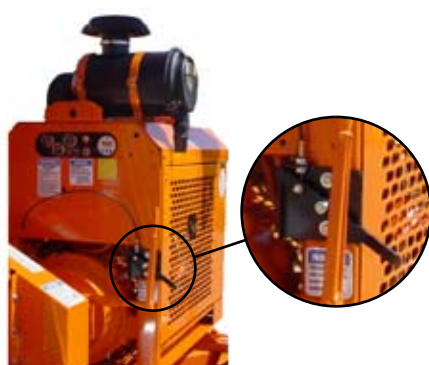

BANDIT THROTTLE SYSTEM

PUSH BUTTON OR ELECTRIC THROTTLE SYSTEM

MACHINE OPERATION

- Check all fluids before starting the machine.
- Make sure to go through the daily start-up and maintenance procedures before operating the machine.
- Drive belts or clutch must be disengaged before starting.
- Make sure the cutter wheel switch is in the “off” position on the remote control.
- Push the remote control power switch to the “on” position.
- Start engine at idle speed and allow for sufficient time for oil to circulate before proceeding.
- Test all controls for proper operation.
- Avoid transversing slopes.

DANGER

DO NOT OPERATE AROUND WATER, GAS, POWER OR PHONE LINES. IF IN DOUBT, CHECK BEFORE GRINDING.

DANGER

WEAR ALL PERSONAL PROTECTIVE EQUIPMENT PER ANSI, OSHA AND MANUALS.

DANGER

KEEP CLEAR OF CUTTING WHEEL, MOVING MACHINE PARTS AND GRINDER DEBRIS FIELD.

Do not run engine, if not in white area of level gauge on boom.

Position machine at stump with cutter wheel a slight distance away from stump.

Extend tongue, if equipped.

Reduce engine RPM to idle.

Drive the holding stake (if equipped) into the ground.

Remove the upper frame lock pin (if equipped).

Raise cutter wheel clear of stump.

Engage the cutter wheel.

Increase engine RPM to full.

Test the controls for proper operation, speed, and unobstructed movement.

The cutter wheel swing speed should be adjusted to a rate that will allow cutter wheel to pass through stump smoothly. If jerking, bouncing or significant drops in engine speed occur, swing rate is too rapid and must be decreased.

Swing speed should be determined and adjusted with the controls in the full open position.

A swing speed control is located on the top or on the side of the control box of the machine to adjust this speed. Turning the dial counter-clockwise will either slow or speed up the swing action, depending on the type of controls (manual or electric) and when the machine was built.

Travel speed should be adjusted to a rate that will allow cutter wheel to approach stump smoothly. If cutter wheel is approaching stump quickly, travel speed is too rapid and must be decreased.

Travel speed should be determined and adjusted with the controls in the full open position.

A travel speed control is located on the side or on the top of the control box of the machine to adjust this speed. Turning the dial counter-clockwise will either slow or increase the travel speed, depending on the type of controls (manual or electric) and when the machine was built.

Lower the spinning cutter wheel to the stump and make a few light passes at the stump to get a feel for the cutting action.

Gradually increase cutting action and work away at the stump by swinging cutter wheel left-to-right-to-left through stump in a sideways motion. Smooth, effortless cutting lengthens machine life, minimizes down time and is more profitable in the long run.

Continue cutting stump by adjusting cutting wheel progressively lower until stump is cut well below ground level.

Swing cutter wheel clear of stump and position machine closer to stump for next series of passes and continue cutting. If the machine is equipped with a tongue extension, reposition the cutter wheel with the tongue extension control.

Continued on the following page.

Bandit

MACHINE OPERATION (cont.)

Continue in this manner until stump has been removed.

Larger stumps may require repositioning machine to remove complete stump.

Raise cutter wheel clear of stump and return to center position.

Withdraw tongue extension (if equipped).

Pull the holding stake (if equipped) and place in transport position.

Reduce engine speed to idle and disengage cutter wheel. **DO NOT TURN OFF MOTOR.** Engine should be allowed to cool slowly at idle for 3-5 minutes to avoid damage.

DO NOT ENGAGE OR DISENGAGE DRIVE BELTS AT A HIGH ENGINE SPEED. Damage to belts and machine will occur.

At low engine RPM, the cutter wheel swing speed control needs to be closed or slowed all the way down for the cutter head to swing. The direction the control knob needs to be turned will depend on the type of controls (manual or electric) and when the machine was built.

Turn off engine.

Allow cutter wheel to come to a complete stop before inspecting.

CUTTING AREA

⚠ DANGER

For optimum performance, the stump should be cut with the portion of the cutter wheel shown below. **NEVER UNDERCUT THE STUMP.** Undercutting the stump may cause severe kickback, vibration and component damage. **NEVER CUT THE STUMP FROM THE TOP.** The cutter wheel will throw debris up and toward the operator, instead of down and under the machine.

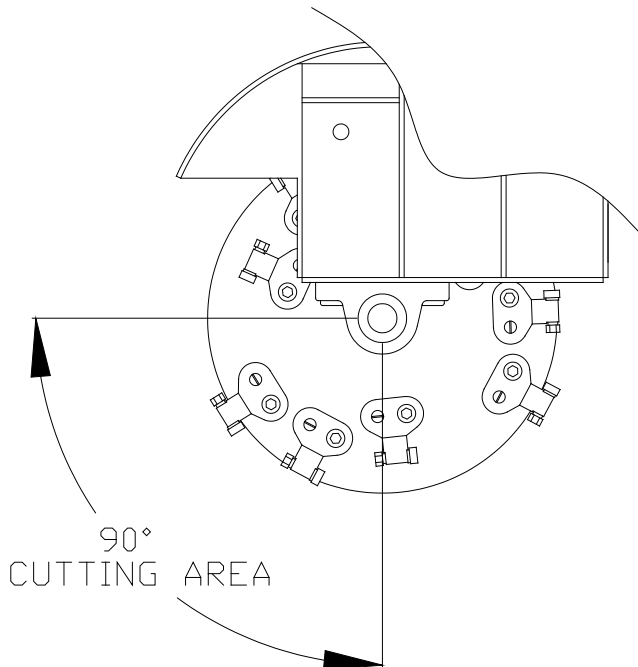

⚠ DANGER

FLYING OBJECTS
STAND CLEAR
OR YOU WILL BE
INJURED!

MOVING A MACHINE WITHOUT POWER

NOTICE

Use this procedure only when the machine will not start or run to help prevent damage to the hydraulic system. With the key in the “off” position and in your possession, follow the steps below:

1. Close the ball valve (see Figure 1) by turning 1/4 of a turn or the needle valve (see Figure 2) by turning the knob clockwise 3 to 4 full turns. It will be located near the bottom of the control cabinet on the outside.
2. Close the ball valve located between the control cabinet and the hydraulic tank, see Figure 3.
3. Pump the brake release 2 to 4 pumps. For a manual control machine, the brake release is located inside of the control cabinet on the left side. For a remote control machine, the brake release is located in between the control cabinet and the tank on the right hand side. See Figure 4.
4. The machine is now in freewheel mode, although there will be drag from the drive wheel motors.
5. Reverse steps 1 and 2 after moving the machine.

Figure 1

Pre 6/09



Figure 2

Start 6/09



Figure 3



Figure 4



TRANSPORTATION PROCEDURES

WARNING

BEFORE TRANSPORTING THE MACHINE, INSPECT AND CONFIRM THE FOLLOWING STEPS:

- 1) The trailer has a cargo weight rating capacity for the weight of the stump grinder. The combined weight of the trailer and the stump grinder can not exceed the load capacity of the tires, axles, hitch coupler system or the GVWR (Gross Vehicle Weight Rating) of the trailer.
- 2) The towing vehicle is rated for and has the towing capabilities to haul the stump grinder package (includes the stump grinder and a trailer). The towing vehicle must be mechanically sound and capable of handling the towing job.
- 3) The hitch on the towing vehicle and the coupler on the trailer is a perfect match in size, type, and needed capacity.
- 4) Both the towing hitch and the coupler are in good mechanical and wear condition, that they are joined together securely, and the coupler/hitch is locked in place.
- 5) The safety chains have the correct capacity for the equipment being towed.
- 6) The safety chains are crossed under the coupler/hitch then securely attached to the towing vehicle. The safety chains are long enough to not restrict the turning movement, but short enough to not drag on the road.
- 7) The electrical plug-in on the towing vehicle and the trailer are wired for the same functions and they fit securely together. The plug-in wire is long enough to not restrict the turning movement, but short enough to not drag on the road. The trailer must have a lighting system and braking system to match and perform correctly off the towing vehicles system. You must meet the Federal and your States' Department of Transportation Code of Regulations concerning lights, brakes, and highway transit.
- 8) The break-away actuator (if equipped) that is installed on the trailer correctly works and is appropriately attached to the towing vehicle.
- 9) All lights and brakes on the trailer correctly functions when activated by the systems in the towing vehicle.
- 10) The tires have been checked for cuts or damaged rims, air pressure is correct, and the axle lug nuts have been checked for correct torque (refer to trailer manual).
- 11) When the stump grinder is on the trailer, the trailer has the right load capacity, the stump grinder is positioned on the trailer for the correct weight distribution (there should be about 15% of the total stump grinder package weight on the tongue or hitch), the stump grinder brakes are locked, the cutterwheel is resting on the trailer bed, and the stump grinder is securely bound down to the trailer bed per your States binding requirements.
- 12) Any loose debris, tools or parts have been cleared off or are put away.
- 13) Close and secure any of the following if equipped: tool box, battery box, engine cowl doors and side panels, radiator debris screens, inspection doors, cabinet doors, housing covers, tank caps and covers, vise, etc.
- 14) Make sure the load ramps are securely stored for transport.
- 15) Make sure the stump grinder's engine is not running, the ignition key is in your possession, and all controls are stored correctly and locked in place for transport.
- 16) The stump grinder package must be hauled level and the towing vehicle must be sized to handle hitch weight and towing weight. The towing vehicle or the combination of towing vehicle and towing package must have enough braking capacity to meet the Federal and your State Department of Transportation requirements.
- 17) The stump grinder package is now ready for transport. Make sure to obey all local regulation and laws regarding the transporting of this type of machine.
- 18) Do not drive too fast for road conditions or exceed speed regulations for equipment towing.

LOADING & UNLOADING

WARNING

BEFORE LOADING OR UNLOADING THE MACHINE INSPECT AND CONFIRM THE FOLLOWING STEPS: When loading or unloading the self-propelled machine on the trailer, use care and caution. The maneuvering of the equipment must be slow, smooth, and intentional, not fast and jerky.

- 1) Make sure the trailer and towing vehicle are parked on a flat surface. They must be stable on the surface with the brakes locked and/or the wheels chocked to avoid unwanted movement.
- 2) Position the loading ramps or loading gate securely between the trailer and the ground level. Have them located so that they are in line with the tires or tracks of the machine when it moves.
- 3) Remove and store the chains and binders used for transporting.
- 4) Confirm that there are not any obstacles on the trailer bed, around the trailer that may cause restricted movement of the machine or the operator.
- 5) The only person in the area should be the one that is operating the machine controls, and he/she should be very experienced with the controls on this machine.
- 6) If you are on streets, roads or public areas, position the warning cones etc, per your company's safety policy.
- 7) Follow all pre-startup instructions for the machine.
- 8) Once the engine is running at as low a speed as possible, carefully raise the cutterwheel slightly up off the ground or trailer bed. While loading or unloading the stump grinder, the cutterwheel should not be raised any higher than necessary to just clear whatever is under it. You need to keep the weight center of gravity as low as possible to avoid tipping the machine while it is moving.
- 9) The cutterwheel end of the stump grinder should always be positioned so that it is toward the rear of the trailer, not the tongue, during transport.
- 10) When the machine is positioned on the trailer bed, there should be about 15% of the total trailer package weight on the tongue or hitch.
- 11) Align the machine with the trailer bed, and the loading ramps. The only equipment movement should be slowly, straight on or straight off the trailer.
- 12) With the engine and the machine at as low of speed as possible, move the machine toward the ramp system. Make sure the alignment is correct throughout the travel, and carefully readjust the cutter wheel height so that it barely clears obstacles as it is going up or down the ramp system.
- 13) Properly secure the equipment and the area to avoid any possible accidents or dangers.
- 14) The trailer should be constructed with appropriate chain down positions for the specific sized stump grinder. You must have binders that will withstand the strain of the machine trying to move while it is being transported.
- 15) The loading ramps or loading gate of the trailer must be constructed to withstand the weight and forces involved in loading and unloading the machine.

MAINTENANCE SECTION

The Bandit is a very simple machine to maintain. If you will follow a regular scheduled preventative maintenance program you should have years of trouble free operation.

⚠ DANGER

Before attempting any type of maintenance disengage clutch, turn off engine, wait for the cutterwheel to come to a complete stop, install the cutter wheel lock pin, place cutter wheel on the ground, disconnect battery, and make sure the ignition key is in your possession.

⚠ DANGER

Do not let anyone operate or maintain this machine until they have thoroughly read this manual, reviewed the equipment decals, watched the equipment video, and has been properly trained. You can purchase additional Bandit manuals, decals and videos for a nominal fee.

NOTICE

Consult your engine manual for proper break-in procedures. Various engines require somewhat different procedures, but basically the engines need to operate at lower R.P.M.'s and loads for a specific time.

NOTICE

Failure to properly break-in your engine may result in poor bearing and piston ring surfaces.

NOTICE

The Bandit has only been run for a short time to test proper hydraulic pressures, possible leaks, etc. The fuel tank will be empty. Fuel is provided through a small auxiliary tank for testing. This immensely helps maintain safety in our manufacturing facility and while shipping.

NOTICE

Expensive damage to the Bandit will occur if proper preparation is not taken before welding on the machine. Be sure to disconnect both battery cables and the engine ECM (engine control module) before welding. Follow the specific Engine MFG. instructions for proper welding and grounding procedures, before attempting to weld on the machine. If welding on the machine, do not ground the welder through the machine bearings, ground near work to be performed.

DAILY START UP & MAINTENANCE

1) Check the safety decals and engine gauges:

Replace any missing or damaged decals and/or engine gauges.

2) Check all safety equipment:

Check for proper operation. Repair or replace as needed.

3) Check entire machine for loose bolts, nuts, parts, or components:

Check entire machine for any loose parts or components. Check for loose nuts or bolts. Torque, tighten, or replace any of the loose components. See page 36 for specific bolt torques.

4) Check all guards:

Check to make sure all guards are in place and installed correctly. Make sure they are secure.

5) Check the cutter wheel and pockets for wear:

Check for elongated bolt holes, secure welds, torqued bolts, excessive wear and impact cracks. If a problem is found contact the grinder manufacturer or an authorized Bandit dealer.

6) Check condition of cutter teeth, pockets, and hardware:

Sharpen or replace your cutter teeth to keep them sharp. Check the condition of your teeth pockets and hardware. Replace if necessary.

DAILY START UP & MAINTENANCE cont.**7) Check cutter wheel pocket bolts:**

All cutter wheel pocket bolts must be factory approved. Bolts must be replaced after a maximum of 4-5 rotations/changes to insure safe clamping ability.

See TORQUE CHART for proper torque.

8) Grease cutter wheel & jackshaft bearings daily:

Use an EP-2 Lithium type grease only for all bearings. Purge cutter wheel and jackshaft bearings with grease. You can not over grease these bearings. These bearings are designed with a relief system that will not allow over greasing. In other words, you can not hurt the bearing seals by pumping in too much grease. Most of the failures related to bearings are diagnosed as "contaminations". Contamination is caused by improper lubrication. Wipe off excess grease. **Excessive grease will attract dirt.**

9) Grease upper frame pivot bushings:

Grease upper frame pivot bushings with 1 to 2 shots of EP-2 Lithium type grease. Wipe off excess grease. **Excessive grease will attract dirt.**

10) Clean debris from engine beltshield & cutter wheel beltshield:

Inspect both beltshields for debris and clean out any chips. Chip build up will wear, stretch, or break the belts.

11) Check / adjust the engine and cutter wheel belt tensions and alignment:

The belts will need to be tightened several times in the first few days of operation. A loose belt will slip and glaze over. Once they slip you must replace them. See pages 40 - 42 for procedures. Check the belt sheaves with a straight edge to ensure they are in line.

12) Check and torque set screws:

Check and torque set screws and / or clamp bolt on hydraulic pump and make sure it is fully inserted into shaft.

13) Check hydraulic oil level:

The hydraulic oil reservoir tank level should always remain at 7/8 full. Remember to check DAILY to avoid excessive heat build up.

14) Check for any fluid leaks:

Inspect for any oil, fuel, or hydraulic oil. Check all hoses, fittings, lines, and tanks. DO NOT use fingers or skin to check for hydraulic leaks. Repair or replace any damaged or leaking components.

15) Check the fuel level:

Check the fuel level, running out and repriming is time consuming. Do not over fill, and you must leave fuel expansion space in the top of the tank.

16) Check engine oil and coolant levels:

Follow the engine manufacturer manual recommendations for fluid levels. You MUST follow specific ENGINE MFG. manual recommendations for radiator coolant, additives, lubrication, correct engine speed, ETC.

17) Check radiator, debris screen:

Thoroughly clean radiator fins at least once a day and twice in excessive condition. Make sure debris is not packed between fins. Use pressurized water spray to clean. Do not rely on air pressure. The radiator will only appear to be clean. A partially plugged radiator will not allow the engine to cool properly. Clean cooling fan, shroud on air cooled engines, and the debris screen (if so equipped). Improper service, maintenance, or neglect will cause overheating problems and engine failure.

18) Check air cleaner or precleaner:

Clean or replace element following engine manual recommendations. Also, check and clean the vacuator valve.

19) Check tires:

Check tires for wear, weather checking and damage. Replace if damaged.

20) Inspect wheel hub dust cap (Model 2150):

Inspect dust caps and replace if damaged or leaking.

21) Check around machine:

Check around the entire machine for tools, cans, saws, etc. All tools not in use should be stored in a tool box.

22) Review all safety procedures on decals, from manual, and from video.**23) Make sure all safety equipment is being worn:**

Make sure you are wearing all of your safety equipment: hard hat, face shield, gloves, eye protection, ear protection, etc. per ANSI and OSHA standards.

24) Remember to check EVERYTHING on the checklist.

WEEKLY MAINTENANCE

1) Grease cutter head swing pivot bearings:

Grease the top and bottom cutter head swing pivot bearings with 1 shot of EP-2 Lithium type grease. Wipe off excess grease. **Excessive grease will attract dirt.**

2) Grease steering axle pivot bushing:

Grease steering axle pivot bushing with 1 to 2 shots of EP-2 Lithium type grease. Wipe off excess grease. **Excessive grease will attract dirt.**

3) Grease steering bearings (Model 2150):

Grease steering bearings with 1 to 2 shots of EP-2 Lithium type grease on the Model 2150XP with the tight turn option. Wipe off excess grease. **Excessive grease will attract dirt.**

4) Grease steering bushings (if equipped):

On Model 2150 with optional 4WD & Model 2450, grease steering bushings with 1 to 2 shots of EP-2 Lithium type grease. Wipe off excess grease. **Excessive grease will attract dirt.**

5) Grease cylinder lug pin bushings:

Grease cylinder lug pin bushings with 1 to 2 shots of EP-2 Lithium type grease. Wipe off excess grease. **Excessive grease will attract dirt.**

6) Grease engagement arm pivot:

Grease engagement arm pivot with 1 to 2 shots of EP-2 Lithium type grease. Wipe off excess grease. **Excessive grease will attract dirt.**

7) Check set screws in bearings:

Check set screws in cutter wheel bearings for tightness.

8) Check and retighten tank mount bolts:

Check the fuel tank and hydraulic tank mount bolts and retighten.

9) Check alternator and fan belts on engine (as applicable):

Adjust and maintain per the engine manufacturer's manual.

10) Check wheel lug nuts:

Keep lug nuts tight, retorque, replace if needed.

MONTHLY MAINTENANCE

1) Grease telescopic tongue (if equipped):

With tongue extended, grease inside tongue with 1 to 2 shots of grease per side and spread evenly.

2) Grease grading blade bushings (if equipped):

Grease grading blade pivot bushings with 1 to 2 shots of EP-2 Lithium type grease. Wipe off excess grease. **Excessive grease will attract dirt.**

3) Check grinder bearings and grinder sheave:

Check, retighten all bearing bolts and belt sheave bushings to correct torques.

4) Tire air pressure:

Fill each tire to rated capacity on tire.

5) Check bearing and bearing lock collars:

Check, retighten bearing lock collars to correct torques.

6) Check hydraulic pressures:

Check, reset and maintain all hydraulic pressure settings to the specified maximum, see page 47. This will give you the best performance from the hydraulic system.

7) Inspect steering motor coupler (Model 2150):

Check and maintain correct torque on motor coupler bolts.

8) Lubricate throttle cable (if equipped):

If the machine is equipped with a manual control throttle system, lubricate inner throttle cable and cable ends with a cable lube or SAE 10W/30 oil. Replace throttle cable if it doesn't operate smoothly.

3 MONTH MAINTENANCE

1) Hydraulic oil filter:

Must be replaced after FIRST 10 HOURS OF OPERATION, USE A 10 MICRON FILTER. After first change replace oil filter every 3 months or 400 hours.

6 MONTH MAINTENANCE

1) Grease outboard bearing (Caterpillar engine):

On Caterpillar engines, grease outboard bearing behind engine sheave every 6 months or 1000 hours. Use 1 to 2 shots of EP-2 Lithium type grease. **DO NOT OVER GREASE.**

2) Grease stub shaft bearing (Kubota engine):

On Kubota engines, grease stub shaft bearing behind engine sheave every 6 months or 1000 hours. Grease the zerk on the end of the stub shaft with 2 to 3 shots. Grease the zerk on the side of the stub shaft until the pin extends from the relief valve on the opposite side of the stub shaft. Use EP-2 Lithium type grease. **DO NOT OVER GREASE.**

Grease zerk on side of stub shaft Relief valve on side of stub shaft



Grease zerk on end of stub shaft

YEARLY MAINTENANCE

1) Hydraulic oil:

Change hydraulic oil and flush the hydraulic reservoir tank.

2) Hydraulic suction screen:

Change hydraulic suction screen yearly or every 2000 hours.

3) Grease wheel hub bearings (Model 2150):

Inspect and clean wheel hub bearings, cups, and seals. Replace seals if ever removed. Grease wheel bearing with an EP-2 Lithium type grease. Remove rubber plug and pump grease into E-Z Lube zerk until all of the old grease is pumped out of the dust cap. Wipe off excess grease and replace rubber plug. **Excessive grease will attract dirt.**

DAILY START UP & MAINTENANCE CHECK LIST

Each day before starting your machine these checks must be made:

	O.K.	Repaired
1) Check the safety decals and engine gauges, replace if damaged.	<input type="checkbox"/>	<input type="checkbox"/>
2) Check, maintain, and service all safety equipment for proper operation.	<input type="checkbox"/>	<input type="checkbox"/>
3) Check entire machine for loose nuts, bolts, and components.	<input type="checkbox"/>	<input type="checkbox"/>
4) Check all guards to make sure they are tight and securely in place.	<input type="checkbox"/>	<input type="checkbox"/>
5) Check the condition of the cutter wheel and teeth pockets.	<input type="checkbox"/>	<input type="checkbox"/>
6) Check the condition of the cutter teeth, pockets, and hardware.	<input type="checkbox"/>	<input type="checkbox"/>
7) Properly torque cutter wheel pocket bolts.	<input type="checkbox"/>	<input type="checkbox"/>
8) Grease (purge) cutter wheel and jackshaft bearings daily.	<input type="checkbox"/>	<input type="checkbox"/>
9) Grease upper frame pivot bushings with 1 to 2 shots.	<input type="checkbox"/>	<input type="checkbox"/>
10) Clean debris from beltshield and poly chain guard.	<input type="checkbox"/>	<input type="checkbox"/>
11) Check and / or adjust engine and cutter wheel belt tensions and alignment.	<input type="checkbox"/>	<input type="checkbox"/>
12) Check and torque set screws and / or clamp bolt on hydraulic pump.	<input type="checkbox"/>	<input type="checkbox"/>
13) Check and always maintain hydraulic oil level at 7/8 full.	<input type="checkbox"/>	<input type="checkbox"/>
14) Check all hoses, fittings, lines, and tanks for damage and fluid leaks.	<input type="checkbox"/>	<input type="checkbox"/>
15) Check fuel level. (Running out and repriming is time consuming).	<input type="checkbox"/>	<input type="checkbox"/>
16) Check engine oil, coolant levels, and correct engine speed. Follow ENGINE MANUFACTURER'S manual specs. Engine Must Be Level To Check Fluids.	<input type="checkbox"/>	<input type="checkbox"/>
17) Check radiator and debris screen. Clean as necessary. Clean cooling fan and shroud on air cooled engines.	<input type="checkbox"/>	<input type="checkbox"/>
18) Check air cleaner, precleaner, and vacuator valve. Clean as necessary.	<input type="checkbox"/>	<input type="checkbox"/>
19) Check condition of the tires.	<input type="checkbox"/>	<input type="checkbox"/>
20) Inspect wheel hub dust cap (Model 2150).	<input type="checkbox"/>	<input type="checkbox"/>
21) Check around the entire machine for any foreign objects, tools, cans, saws, etc.	<input type="checkbox"/>	<input type="checkbox"/>
22) Review all safety procedures on decals, from manual, and from video.	<input type="checkbox"/>	<input type="checkbox"/>
23) Wear all applicable safety equipment: hard hat, face shield, gloves, eye protection, ear protection, etc.	<input type="checkbox"/>	<input type="checkbox"/>
24) Remember to check EVERYTHING on the checklist.	<input type="checkbox"/>	<input type="checkbox"/>

 DANGER

DO NOT sit, stand, lay, climb or ride anywhere on this machine while it is running, operating or in transit.

YOU WILL BE INJURED!

 WARNING



WEAR EYE & PERSONAL PROTECTION EQUIPMENT

Wear all personal protection equipment and follow all safety standards per ANSI and OSHA instructions.

WEEKLY CHECK LIST

	O.K.	Repaired
1) Grease top and bottom cutter head swing pivot bearings with 1 shot.	<input type="checkbox"/>	<input type="checkbox"/>
2) Grease axle pivot bushings with 1 to 2 shots.	<input type="checkbox"/>	<input type="checkbox"/>
3) Grease steering bearings with 1 to 2 shots (Model 2150).	<input type="checkbox"/>	<input type="checkbox"/>
4) Grease steering bushings with 1 to 2 shots (Model 2150 With 4WD & 2450).	<input type="checkbox"/>	<input type="checkbox"/>
5) Grease cylinder lug pin bushings with 1 to 2 shots.	<input type="checkbox"/>	<input type="checkbox"/>
6) Grease engagement arm pivot with 1 to 2 shots.	<input type="checkbox"/>	<input type="checkbox"/>
7) Check set screws in bearings.	<input type="checkbox"/>	<input type="checkbox"/>
8) Check and retighten fuel / hydraulic tank mount bolts.	<input type="checkbox"/>	<input type="checkbox"/>
9) Check alternator and fan belts on engine.	<input type="checkbox"/>	<input type="checkbox"/>
10) Check and retighten wheel lug nuts.	<input type="checkbox"/>	<input type="checkbox"/>

MONTHLY CHECK LIST

	O.K.	Repaired
1) Grease inside telescoping tongue with 1 to 2 shots and spread evenly (if equipped).	<input type="checkbox"/>	<input type="checkbox"/>
2) Grease grading blade pivot bushing with 1 to 2 shots (if equipped)	<input type="checkbox"/>	<input type="checkbox"/>
3) Check grinder bearings and grinder sheaves.	<input type="checkbox"/>	<input type="checkbox"/>
4) Check and fill tires to rated pressures.	<input type="checkbox"/>	<input type="checkbox"/>
5) Check bearing and bearing lock collars.	<input type="checkbox"/>	<input type="checkbox"/>
6) Check hydraulic pressure. Set to specified PSI (bar).	<input type="checkbox"/>	<input type="checkbox"/>
7) Inspect steering motor coupler and check torque on bolts (Model 2150).	<input type="checkbox"/>	<input type="checkbox"/>
8) Lubricate throttle cable (if equipped).	<input type="checkbox"/>	<input type="checkbox"/>

3 MONTH CHECK LIST

	O.K.	Repaired
1) Replace hydraulic oil filter after first 10 hours, then quarterly or every 400 hours.	<input type="checkbox"/>	<input type="checkbox"/>

6 MONTH CHECK LIST

	O.K.	Repaired
1) Grease outboard bearing behind engine sheave every 6 months or every 1000 hours (Caterpillar engine only).	<input type="checkbox"/>	<input type="checkbox"/>
2) Grease stub shaft bearing behind engine sheave every 6 months or every 1000 hours (Kubota engine only).	<input type="checkbox"/>	<input type="checkbox"/>

YEARLY CHECK LIST

	O.K.	Repaired
1) Change hydraulic oil and flush the hydraulic tank.	<input type="checkbox"/>	<input type="checkbox"/>
2) Replace the hydraulic suction screen(s) annually or every 2000 hours.	<input type="checkbox"/>	<input type="checkbox"/>
3) Inspect and clean wheel hub bearings, cups, and seals. Grease wheel hub bearings. Replace seals if ever removed. (Model 2150).	<input type="checkbox"/>	<input type="checkbox"/>

Bandit

BOLT TORQUE CHART

(THESE TORQUES ARE BASED ON DRY, CLEAN THREADS)

DESCRIPTION	BOLT SIZE	TORQUE (FT.-LBS.)	TORQUE (Nm)
Grinder Bearing Bolts	1/2"-13 NC	95	129
Grinder Bearing Set Screws		57	77
Engine Hold Downs	1/2"-13 NC	95	129
Engine Sheave Bushing (SH)	1/4"-20 NC	9	12
Engine Sheave Bushing (SDS)	1/4"-20 NC	9	12
Jackshaft Sheave Bushing (SK) - Model 2150	5/16"-18 NC	15	20
Jackshaft Sheave Bushing (SF) - Model 2150	3/8"-16NC	30	41
Jackshaft Sprocket Bushing - Model 2450		23	31
Cutter Wheel Sprocket Bushing - Model 2450		23	31
Cutter Wheel Bushing - Model 2150	5/16"-18 NC	15	20
Cutter Wheel Green Tooth Pocket Bolts	5/8"-18 NF	125 - 150	169 - 203
Cutter Wheel Green Tooth Nut - Model 2150		20 - 28	27 - 38
Cutter Wheel Green Tooth Nut - Model 2450		31 - 43	42 - 58
Steering Motor Coupler Bolts	1/2"-13 NC	60	81
Lug Nuts	1/2"-20 NF	90 - 120	122 - 163

Before tightening bolts be sure you have the correct size bolt for the correct amount of torque.
Use only factory approved bolts and hardware.

! WARNING



WEAR EYE & PERSONAL PROTECTION EQUIPMENT

Wear all personal protection equipment and follow all safety standards per ANSI and OSHA instructions.

! WARNING



FROZEN BATTERY WILL CAUSE BATTERY TO EXPLODE.

Tow machine inside and allow battery to warm up before using jumper cables. If machine must be started outside, inspect the battery acid for ice formation.

Never use jumper cables in a confined or un-ventilated area. Battery acid vapors are explosive. Keep all spark producing items, open flames, or other ignition sources away from the battery.

! DANGER



MOVING PARTS!



KEEP HANDS CLEAR!

PAINT CARE

To help keep up the appearance of your Bandit Equipment and reduce the possibility of surface rust follow these steps:

- 1) The machine should be washed on a regular basis with a non-abrasive mild detergent and then rinsed thoroughly. Do not pressure wash sensitive areas like: decals, gauges, electronic devices, autofeed control, etc.
- 2) If a stone chip, paint scratch, or paint crack occurs - it should be repaired immediately. Simply sand the edges of the damaged paint area, mask off the surrounding area and apply primer and paint to the dry, clean, and warm surface. This will help keep the damaged area from spreading or getting worse.
- 3) If you are unable to sand and mask the area, there are containers of primer and paint available. A small brush can be used to touch up the area.
- 4) Also, primer and most colors of paint are available in aerosol spray cans to simply spray over the effected area after it is cleaned, dry, and warmed. This method is not as reliable as the process in step #2.

It is also reported that some equipment owners polish their machine at least yearly, and keep good mud flaps on their towing trucks.

 **DANGER**

- DO NOT OPERATE THIS UNIT WITHOUT GUARD IN PLACE.
- DO NOT REMOVE GUARD WHILE UNIT IS IN OPERATION.
- WAIT FOR ALL MOVING PARTS TO COME TO A COMPLETE STOP BEFORE SERVICING MACHINE.
- DO NOT LEAVE CONTROLS UNTIL THE CUTTER WHEEL COMES TO A COMPLETE STOP. NOTE: THE CUTTER WHEEL WILL CONTINUE TO MOVE ONCE THE MACHINE IS SHUT OFF.
- KEEP HANDS, FEET AND LOOSE CLOTHING AWAY FROM MOVING PARTS.
- ALWAYS MAKE SURE AREA IS CLEAR BEFORE STARTING MACHINE.

NOTICE

DECAL MAINTENANCE IS THE RESPONSIBILITY OF THE OWNER OF THIS MACHINE. KEEP DECALS LEGIBLE. DECALS (ETC.) ARE AVAILABLE IN OTHER LANGUAGES.

CONTACT: PARTS DEPARTMENT
6750 MILLBROOK RD.
REMUS, MI USA 49340
PHONE (888) 748-6348

LUBRICATION CHART

#	DESCRIPTION	CHECK			PROCEDURE
		DAY	WEEK	MONTH	
1	Grinder Bearings	X			Purge bearings daily - wipe off excess
2	Jack Shaft Bearings	X			Purge bearings daily - wipe off excess
3	Upper Frame Pivot Bushings	X			1 to 2 shots of grease - wipe off excess
4	Swing Pivot Bearing		X		1 shot of grease - wipe off excess
5	Steering Axle Pivot Bushings		X		1 to 2 shots of grease - wipe off excess
6	Steering Bushings / Bearings		X		1 to 2 shots of grease - wipe off excess
7	Cylinder Lug Pin Bushings		X		1 to 2 shots of grease - wipe off excess
8	Engagement Arm Pivot		X		1 to 2 shots of grease - wipe off excess
9	Telescopic Tongue			X	1 to 2 shots of grease per side of tongue
10	Grading Blade Bushings			X	1 to 2 shots of grease - wipe off excess
11	Bandit Throttle Cable			X	Lubricate inner cable & ends SAE 10W/30
12	Outboard Bearing - CAT Engine			6 Months	1 to 2 shots of grease - wipe off excess
13	Stub Shaft Bearing - Kubota Eng.			6 Months	2 to 3 shots of grease - wipe off excess
14	Stub Shaft Bearing - Kubota Eng.			6 Months	until relief pin extends - wipe off excess
15	Wheel Hub Bearings			Yearly	Repack with grease - wipe off excess

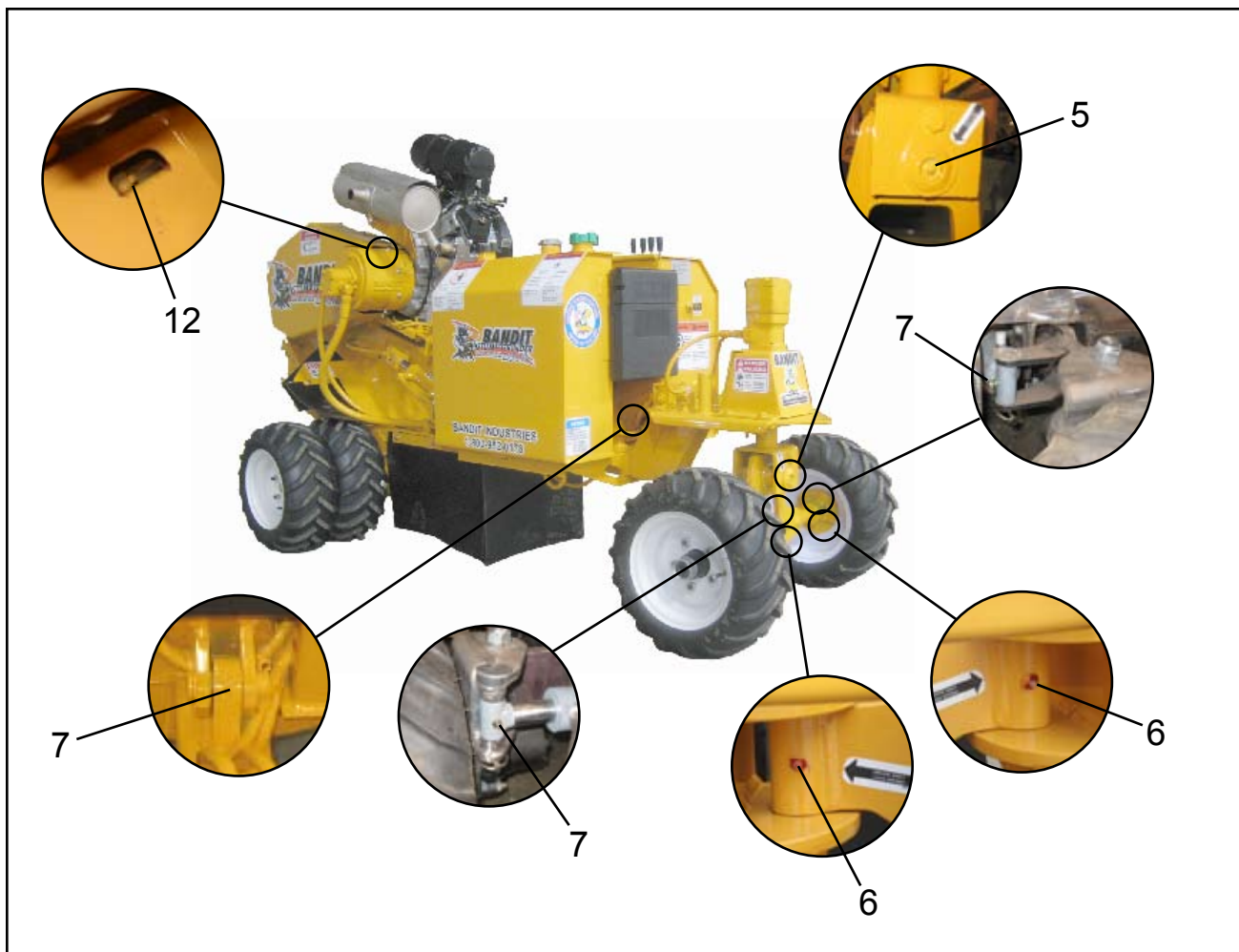

NOTICE Use as a reference only, locations may vary depending on options or component manufacturer. Lubrication point instructions are described on the machine, in the Lubrication & Coolant Section and Maintenance Section of this manual, or component manufacturer's manual.

Bandit

LUBRICATION CHART

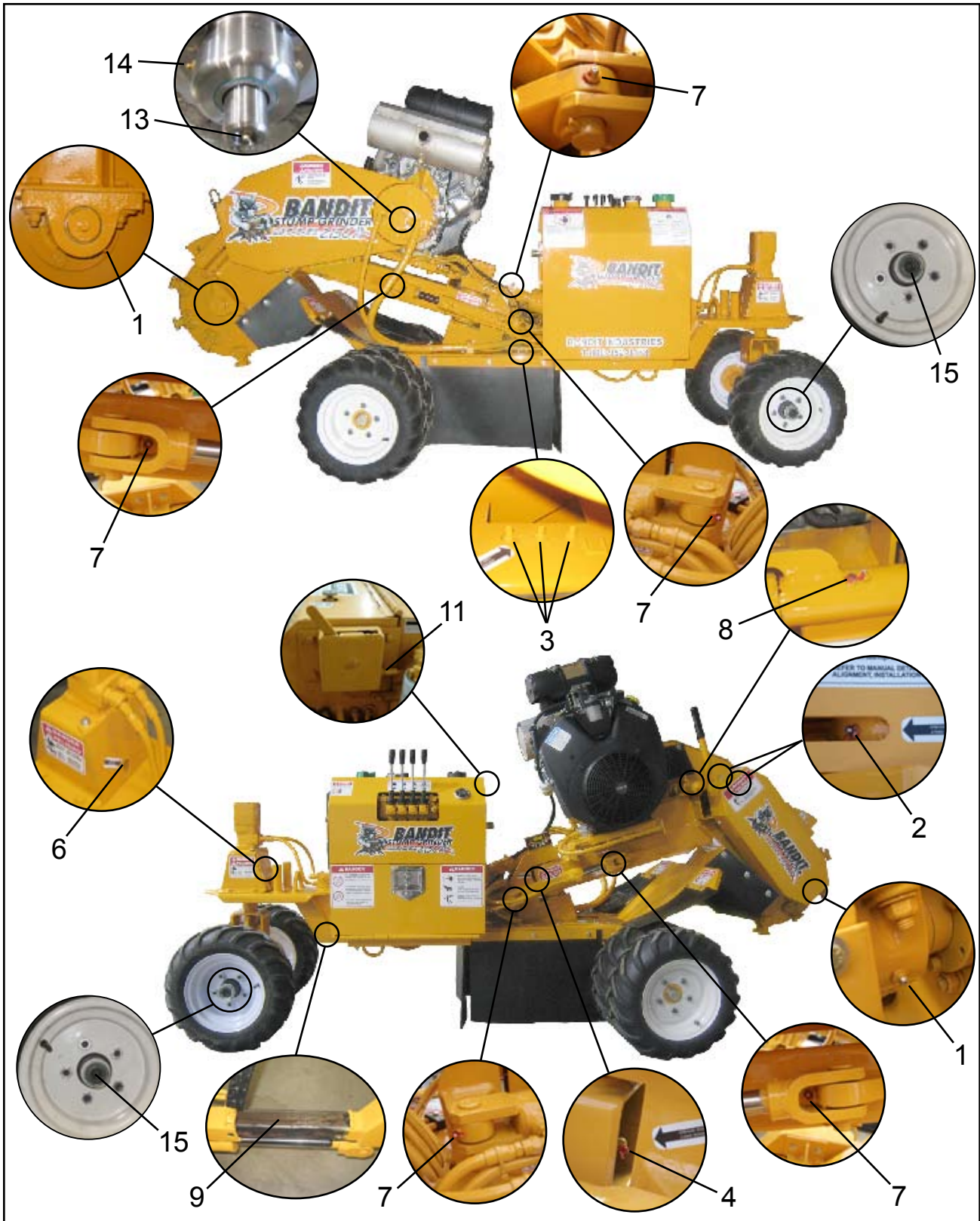

NOTICE Use as a reference only, locations may vary depending on options or component manufacturer. Lubrication point instructions are described on the machine, in the Lubrication & Coolant Section and Maintenance Section of this manual, or component manufacturer's manual.

Bandit

BELT TENSION

GENERAL RULES FOR TENSIONING

1. Check tensioning during the first 2 through 48 hours of run-in operation especially.
2. Over tensioning or under tensioning shortens belt and bearing life.
3. Keep belts free from foreign materials that may cause the belt to slip.
4. Make V-drive inspection on a periodic basis. Never use belt dressing as this will damage the belt and cause early failure.
5. Belts should never be forced over the sheave. Allow enough room for belts to slip on.
6. Always make sure sheaves are aligned properly.

TENSIONING PROCEDURE

Main Drive Belts

Follow all pre-maintenance shut down procedures. Locate the center of the belt span between the sheaves. Push or pull on the belt until the belt has deflected the specified distance (see NOTICE below). Record the push or pull force. The specified force varies depending if the belt is new or used. Adjust the belt tension if the force falls outside of this range. If belts are not properly adjusted belts will slip, glaze over, and be ruined. This is **NOT** covered by warranty.

NOTICE It is a good practice to rotate the belts during tensioning. Then recheck deflections. The belts may need to be tightened again.

DO NOT IGNORE THIS MAINTENANCE RULE!

New belts stretch very soon and must be adjusted several times in the first few hours of operation. Adjust after one hour of operation, then every four hours until the belts quit stretching.

Failure to do this will cause the belts to burn and fly off. **THIS FAILURE IS NOT COVERED BY WARRANTY!**

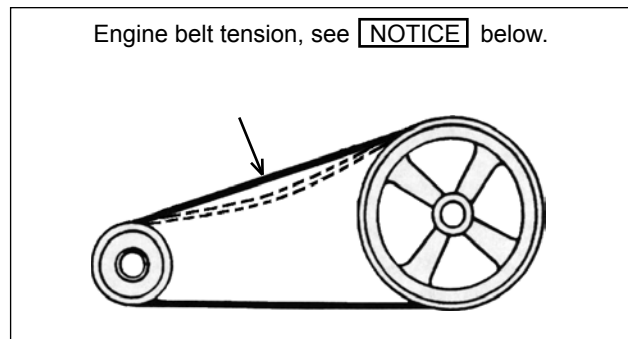
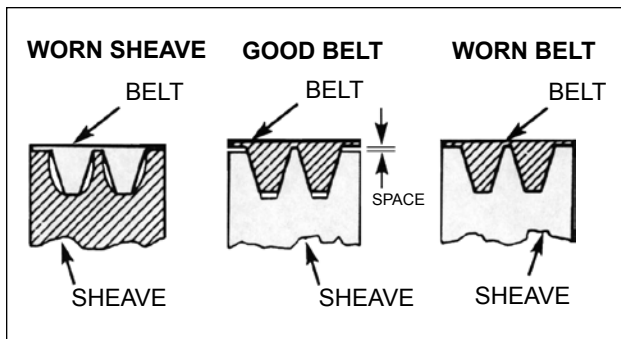

ENGINE BELTS

NOTICE

- New Belt: 5/16" (7.9 mm) deflection at 23 - 26 lbs. (10.4 - 11.8 kg) of force.
- Used Belt: 5/16" (7.9 mm) deflection at 20 - 23 lbs. (9.1 - 10.4 kg) of force.

CUTTER WHEEL BELT (V-Belt & Poly Chain Belt)

Special care needs to be taken with your cutter wheel belt. Alignment, tension, and cleanliness of this belt is very important. The cutter wheel belt needs to be checked for tension approximately every 70 to 100 hours of use. The cutter wheel belt must be running true. If you adjust one bearing more than the other, the belt will run on an angle which will cause belt failure. When replacing the cutter wheel belt, do not try to pry the belt on over pulley, this can break the fibers in the cutter wheel belt. After you have installed or re-tensioned the cutter wheel belt, you will have to readjust the engine belt for proper tension.

Remove the cutter wheel belt guard and jack shaft mount cover. Loosen cutter wheel belt by moving jack shaft bearings back toward rear of machine. Mark them so that you know how they are positioned on the jack shaft plate. Loosen, do not remove, the four bolts that hold the jack shaft bearings down. Loosen the jam bolts in the back and move the bearings back toward cutter wheel. Remove the old belt and replace with a new one.

To adjust tension of the belt, slide the bearings back into the place that you had marked. Tighten the jam bolts. To tighten the belt more if needed, loosen the front jam bolts and tighten each of the back jam bolts the same number of revolutions, to keep the alignment true. Then once the belt is adjusted, tighten the front jam bolts back against the bearing. Check cutter wheel belt sheaves or sprockets, with a straight edge to ensure that they are in line. You will also have to check engine belt for tightness and straightness after adjusting the cutter wheel belt.

NOTICE

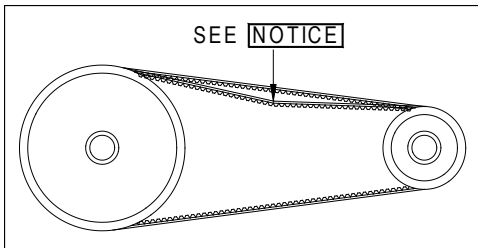

Model 2150 V-Belt

- New: 5/16" (7.9 mm) deflection at 17 - 20 lbs. (7.7 - 9.1 kg) of force.
- Used: 5/16" (7.9 mm) deflection at 14 - 17 lbs. (6.4 - 7.7 kg) of force.

Model 2450 Poly Chain Belt

- New: 5/16" (7.9 mm) deflection at 12 - 14 lbs. (5.4 - 6.4 kg) of force.
- Used: 5/16" (7.9 mm) deflection at 10 - 12 lbs. (4.5 - 5.4 kg) of force.

Poly Chain Sprocket Alignment and Installation - Model 2450

Sheave or sprocket alignment is very important. Proper alignment allows the load to be transferred equally across belt width, which reduces wear and improves belt life.

1. Place a straight edge on the outside of the drive sheave or sprocket, making sure that the straight edge touches the outside and inside of the sheave or sprocket.
2. Move the sheave or sprocket until the straight edge touches both outside edges and inside edges.
3. Make sure the sheaves or sprockets are properly aligned. Alignment should be within 1/4 degree. This is the maximum "M" dimension of .05" per foot (1.3 mm per 305 mm) center distance.

ANGULAR MISALIGNMENT

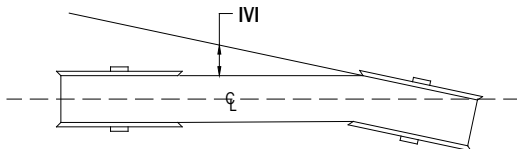

PARALLEL MISALIGNMENT

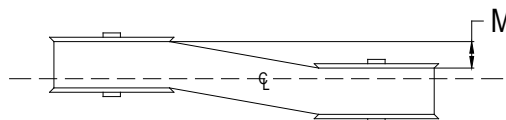

Sheave or Sprocket Installation

1. Inspect the bore of the sheave or sprocket and the bushings tapered surface. Remove any oil, dirt or grease.
2. Place bushing in the sheave or sprocket inserting screw loosely.
3. Place key in key set and slide sheave or sprocket to its desired location with the screw head facing outside. If bushing goes on hard check shaft for burrs, remove if necessary.
4. Check for proper alignment of belts and evenly tighten bolts to recommended torque (SEE PAGE 36).

NOTICE

Adjust jackshaft (cutter wheel belt) first, then engine belt.

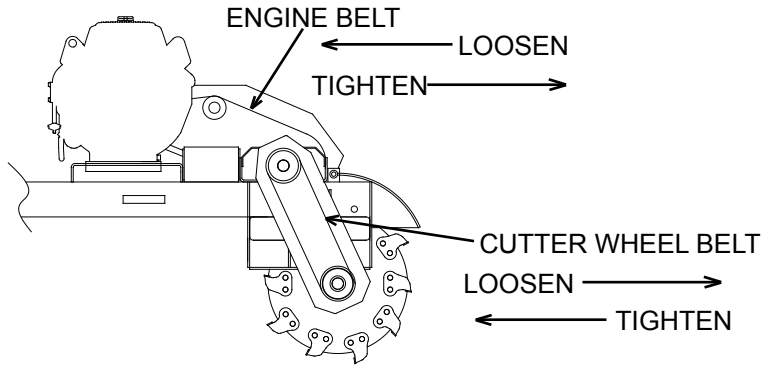

ENGINE BELT

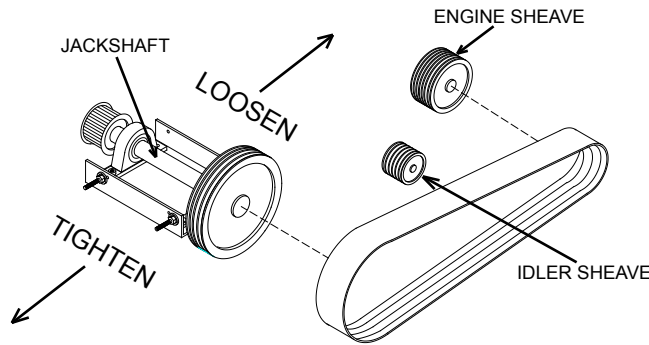

CUTTER WHEEL BELT

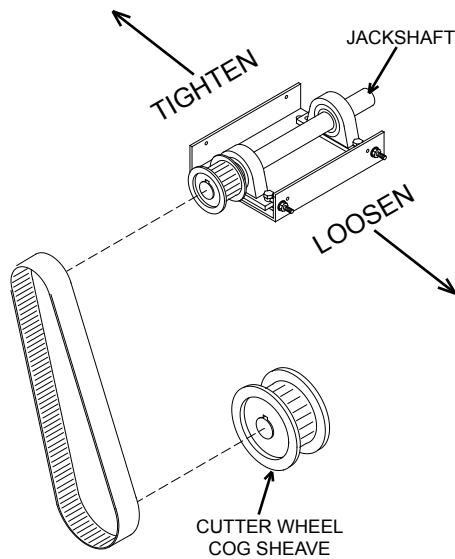

NOTICE

Adjust each jam nut the EXACT same revolutions to maintain proper sheave alignment.

TROUBLE SHOOTING

PROBLEM	POSSIBLE CAUSE	SOLUTION
Engine will not start. (See Engine MFG. manual for further information.)	<ol style="list-style-type: none"> 1. Loose ground cable. 2. Loose hot cable. 3. Dead battery. 4. Cutter wheel was engaged before the machine engine was started. 5. Batteries in remote are dead. 6. Kill switch on remote is activated. 	<ol style="list-style-type: none"> 1. Clean and tighten. 2. Clean and tighten. 3. Recharge or replace. 4. Switch cutter wheel to off, make sure key switch is off, and then restart the machine. 5. Replace. 6. Twist and pull out.
Cutter wheel vibration.	<ol style="list-style-type: none"> 1. Tooth missing. 2. Pocket out of balance. 3. Improper tooth arrangement. 4. Bad cutter wheel shaft bearing. 	<ol style="list-style-type: none"> 1. Replace missing teeth. 2. Always replace pockets in pairs across from each other. 3. Install correctly with like pairs of teeth directly across from each other. 4. Replace.
Belt squeal.	<ol style="list-style-type: none"> 1. Belt tension too loose. 2. Belt out of alignment. 	<ol style="list-style-type: none"> 1. Tighten or replace. 2. Align pulleys.
Belt jumping off.	<ol style="list-style-type: none"> 1. Engaging or disengaging belt at high engine RPM. 2. Belt keeper too far from belt. 3. Belt out of alignment. 	<ol style="list-style-type: none"> 1. Only engage or disengage belts at low engine speed or need replacement. 2. Adjust belt keeper closer to belt. 3. Make sure sheaves aligned properly.
Cutter wheel throwing teeth.	<ol style="list-style-type: none"> 1. Bad pocket. 2. Dirt in pocket. 	<ol style="list-style-type: none"> 1. Replace pocket. 2. Clean pocket and replace missing teeth.
Cutter wheel breaking teeth.	<ol style="list-style-type: none"> 1. Operator hitting rocks. 	<ol style="list-style-type: none"> 1. Avoid rocks, stone, etc.
Cutter wheel stops turning.	<ol style="list-style-type: none"> 1. Belt or clutch not engaged. 2. Belt loose. 3. Engine belt broke. 4. Cutter wheel belt broke. 5. Sheared key in shaft. 6. Broke cutter wheel shaft. 	<ol style="list-style-type: none"> 1. Adjust belt assembly or clutch. 2. Tighten. 3. Replace. 4. Replace. 5. Replace. 6. Replace.
Roar in machine when cutter wheel is engaged.	<ol style="list-style-type: none"> 1. Belt guards rubbing on motor shaft or cutter wheel shaft. 2. Cutter wheel or jack shaft bearings going bad. 	<ol style="list-style-type: none"> 1. Reposition guards off of shafts. 2. Replace bearings.
Bearing will not take grease.	<ol style="list-style-type: none"> 1. Grease fitting clogged. 	<ol style="list-style-type: none"> 1. Replace.
Machine will not respond to remote.	<ol style="list-style-type: none"> 1. Weak or dead batteries in remote. 2. Remote not turned on before starting the machine engine. 3. Machine is out of range of the remote. 4. Broken or damaged antenna. 5. Remote power switch was turned off. 	<ol style="list-style-type: none"> 1. Replace. 2. Turn off engine, turn remote power on, and then start engine. 3. Move closer to the machine and make sure there are no obstructions between operator and machine. 4. Replace. 5. Shut down and restart the machine.

HYDRAULIC SECTION

⚠ WARNING

DO NOT GO NEAR HYDRAULIC LEAKS!

High pressure oil easily punctures skin causing serious injury, gangrene, or death. If injured, seek emergency medical help. Immediate surgery is required to remove oil. DO NOT use fingers or skin to check for leaks. Lower load or relieve hydraulic pressure before loosening fittings.

⚠ WARNING

DO NOT operate this machine unless all hydraulic control devices operate properly. They must function, shift and position smoothly and accurately at all times. Faulty controls can cause personal injury!

HYDRAULIC FLUID REQUIREMENTS

This machine is equipped with “Petro-Canada Hydrex XV” hydraulic fluid. It is recommended to replace with the same. “Petro-Canada Hydrex XV” is an all season hydraulic fluid. This is a premium performance, long life anti-wear, hydraulic fluid, designed for all season use in heavy duty hydraulic systems. “Petro-Canada Hydrex XV” allows year round use under wide extremes of temperature. It allows the hydraulic system to start at temperatures as low as -40°C/-40°F, under no load conditions and it improves lubrication of hydraulic components at high operating temperatures. It will also help protect against hydraulic failures during the wide temperature swings of spring and fall. To find the closest “Petro-Canada Hydrex XV” dealer call 1-888-284-4572.

Multi Viscosity motor oils are not recommended to mix with “Petro-Canada Hydrex XV” hydraulic oil. AW oils may mix with “Petro-Canada Hydrex XV” hydraulic oil. The following are specifications and authorizations of compatible oils. Only a high quality anti-wear (AW) hydraulic oil containing foam, corrosion, rust and oxidation inhibitors should be used. This viscosity grade depends on the oil temperature in service, based on the climate and operating conditions.

	Hydrex XV	ISO 22, AW	ISO 32, AW	ISO 46, AW	ISO 68, AW	ISO 100, AW
Viscosity Index	>235	>95	>95	>95	>95	>95
Flash Point	>240°C /464°F	>200°C /395°F	>210°C /410°F	>220°C /430°F	>220°C /430°F	>240°C /464°F
Oxidations Stability (ASTM D0943)	>9,000 Hours	>3,000 Hours	>3,000 Hours	>3,000 Hours	>3,000 Hours	>3,000 Hours
Cold Start-up, No Load, Max	-40°C/-40°F	-34°C/-29°F	-26°C/-14°F	-19°C/-3°F	-9°C/16°F	-4°C/24°F

HYDRAULIC SECTION

Alternate hydraulic oils are available, but they do not equal the performance or longevity of the "Hydrex XV" oil. Consult the following information supplied by the oil distributor.

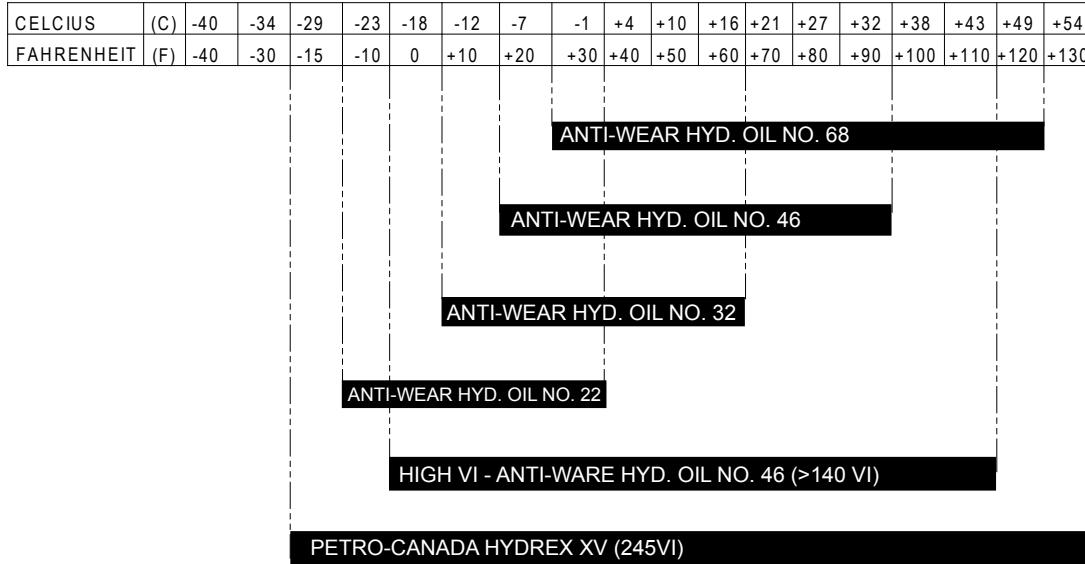

Note: The above chart is a suggested guide for viscosity of hydraulic fluids at start up ambient temperature. The load, demand, and cleanliness of the equipment will affect actual oil temperatures which can increase dramatically above ambient air temperatures during operation. The actual viscosity needed is based on oil temperature during operation and not air temperature. Compare your fluid specifications with the specifications below to verify compliance.

When choosing a hydraulic fluid - these maximum and minimum specifications must be met:

Minimum Viscosity during operation = 12 cSt
 Maximum No-Load Viscosity at start-up = 2000 cSt

Hydraulic fluids vary in their resistance to oxidation at elevated temperatures, their ability to protect against metal-to-metal contact under increasing temperature, and their ability to separate water from the fluid. Viscosity is temperature dependant. Fluids with high viscosity-index (VI) will thin out slower at higher temperature and thicken slower at colder temperatures allowing a wider operating range. Choose a fluid that has test results in these areas for best results.

Based on the varying temperatures of the area where Bandit equipment is used, and the high demand and loads placed on this equipment, Bandit has filled each hydraulic system with Petro-Canada's Hydrex XV All Season Hydraulic Fluid for maximum protection and performance.

Contact Petro Canada at (888) 284-4572 to find a dealer near you.

NOTICE

Some equipment and components such as fluid engagement clutch's (PTO's) have their own lubrication requirements. Consult their manufactures manual for that information.

HYDRAULIC SECTION

THE BANDIT HYDRAULIC SYSTEM

The Bandit is equipped with a very efficient, simple hydraulic system. Each component is capable of withstanding a specified PSI (bar) and still operate for a very long time.

If the simple rules mentioned below are followed, the hydraulic components will last for years:

- After you have operated a new machine for approximately an hour shut down the machine and recheck all hydraulic fittings for tightness and leaks.
- Avoid hydraulic pump cavitation. Low oil levels or cold start-ups will cause the hydraulic pump to cavitate. Cavitation will ruin the pump and possibly the entire hydraulic system. Cavitation only has to happen once. This will start the pump on its way to ruin. Allow hydraulic system to turn slowly for several minutes in cold weather in order for hydraulic system to warm up. Cavitation is not covered under warranty.
- Do not increase the relief valve settings beyond specified PSI (bar). This will cause damage to hydraulic components. Do not set any other hydraulic component past it's specified pressure or this will cause damage to the hydraulic components.
- Keep hydraulic oil clean. Dirty oil will cause excessive wear and loss of hydraulic power.
- Replace the hydraulic oil filter(s) after first 10 hours and with each 400 hours of operation or 3 months.
- Replace hydraulic oil & suction screen(s) at least once yearly. This is also a very good time to flush and clean the tank. Replace hydraulic oil immediately if it is contaminated or looks "milky". See pages 44 - 45 for hydraulic oil requirements.
- If the Bandit's hydraulic system is kept clean and the hydraulic pressures are not increased beyond the specified PSI (bar), the maximum use and life should be received from the Bandit grinder hydraulic system.
- If a problem is encountered, it will more than likely be located in the relief valve or something as simple as belts slipping, check these first.
- Do not close the hydraulic shut-off valve for more than 3 to 4 seconds. Hydraulic shut-off valve handle must be completely turned on at all times unless checking hydraulic pressure. Pressure gauge should be safely stored and installed only when checking pressure. Follow above instructions or this will cause unwarranted damage to the hydraulic components.
- Never close the ball valves on the hydraulic tank suction ports (if equipped) while the machine is running, this will ruin the hydraulic pump and components.
- Some component manufacturers require different specific hydraulic lubrication, such as gear boxes, undercarriage drives, etc. Refer to their manuals and maintenance section of this manual.



**TYPICAL HYDRAULIC RELIEF PRESSURE SETTINGS
TYPICAL HYDRAULIC FLOWS AND RPM SETTINGS
(Approximate, For Reference Only, Engine At Full RPM)**

Equipment Model	2150XP	2150XP - Kubota Engine	2450XP
Pump GPM (LPM)	4 (15)	5 (19)	5 (19)
Main Relief PSI (bar)	2650 (183)	2400 (165)	2400 (165)
Steering PSI (bar)	1000 (69)	1000 (69)	1000 (69)
Cutter Wheel Down PSI (bar)	1000 (69)	1000 (69)	1000 (69)
Optional Tongue Extension PSI (bar)	1000 (69)	N/A	N/A
Optional Grading Blade PSI (bar)	1000 (69)	1000 (69)	1000 (69)

NOTICE The main relief may be the only adjustable pressure on some machines.

NOTICE

DO NOT UNDER ANY CIRCUMSTANCES OVER-SET THESE RELIEF PRESSURES, BECAUSE IT WILL CAUSE DAMAGE TO COMPONENT PARTS AS WELL AS HYDRAULIC PARTS.

NOTICE

These Typical Hydraulic Flows And Relief Pressure Settings Are With The Engine At Full RPM. All Settings Are Subject To Change!

CAUTION

After the initial start-up of the machine and after any replacement of hydraulic components, that fittings and hoses should be re-checked for leaks and clearances.

NOTICE

When returning hydraulic components for warranty make sure to box up all warranted parts to avoid additional damage while shipping. **Do not disassemble any hydraulic components which are to be warranted.** Anything which has been disassembled or tampered with will not be warranted. Items being returned must be clean. All hydraulic components must have all hosing ports plugged. Failure to plug ports will allow debris to enter components which will void warranty.

CHECKING HYDRAULIC PRESSURE

The relief valve is typically located internally in the valve bank. Do not adjust the relief valves above the specified psi (bar). The relief valve system is a simple spring tension design but small pieces of debris can stick the valve partially open which weakens the hydraulic power. The relief as well as hydraulic oil, and suction screen must be kept clean.

WARNING

Before attempting to check any pressures, make sure engine is shut off, ignition key is removed and in your possession, hydraulic oil is clean, hydraulic tank is 7/8 full, and the machine has been pre-run to warm the hydraulic oil. To correctly check relief valve pressure, the pressure gauge MUST be installed correctly.

CHECKING MAIN RELIEF PRESSURE

1. Make sure all the controls are in the off position.
2. Install pressure gauge into the test port.
3. Start engine and adjust engine to full throttle.
4. Pull the cutter wheel lift control lever or switch on remote controlled machines towards the operator so that the cylinder bottoms out and then read the pressure gauge.
5. Adjust relief if necessary. Turn the relief clockwise to increase pressure and counter-clockwise to decrease the pressure.

CHECKING FUNCTION PRESSURE

1. Make sure all the controls are in the off position.
2. Install pressure gauge into the test port.
3. Leave all hydraulic hoses connected.
4. Start engine and adjust engine to full throttle.
5. Activate the function you would like to check with the control lever or remote switch so that the cylinder bottoms out or the steering motor (if equipped) stalls against the swivel stops. The drive motor lines will need to be plugged off to check the drive pressure on remote controlled machines.
6. Adjust relief if necessary. Turn the relief clockwise to increase pressure and counter-clockwise to decrease the pressure.

CHECKING HYDRAULIC PRESSURE

MANUAL CONTROLS

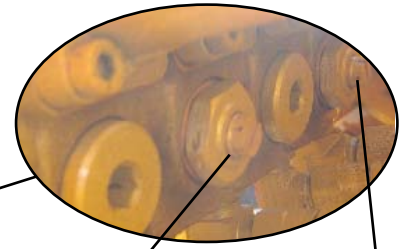
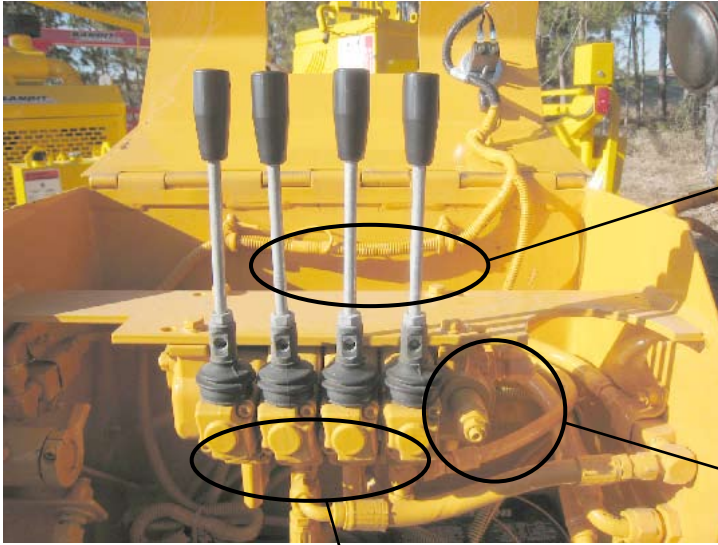

Cutter Down Relief

Steer Relief

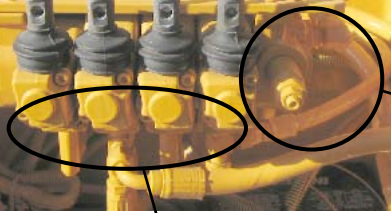

Steer Relief

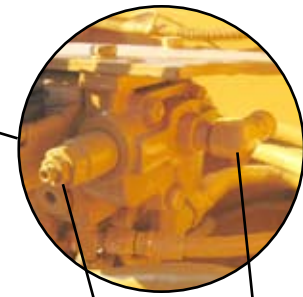

Main Relief

Test Port

REMOTE CONTROLS

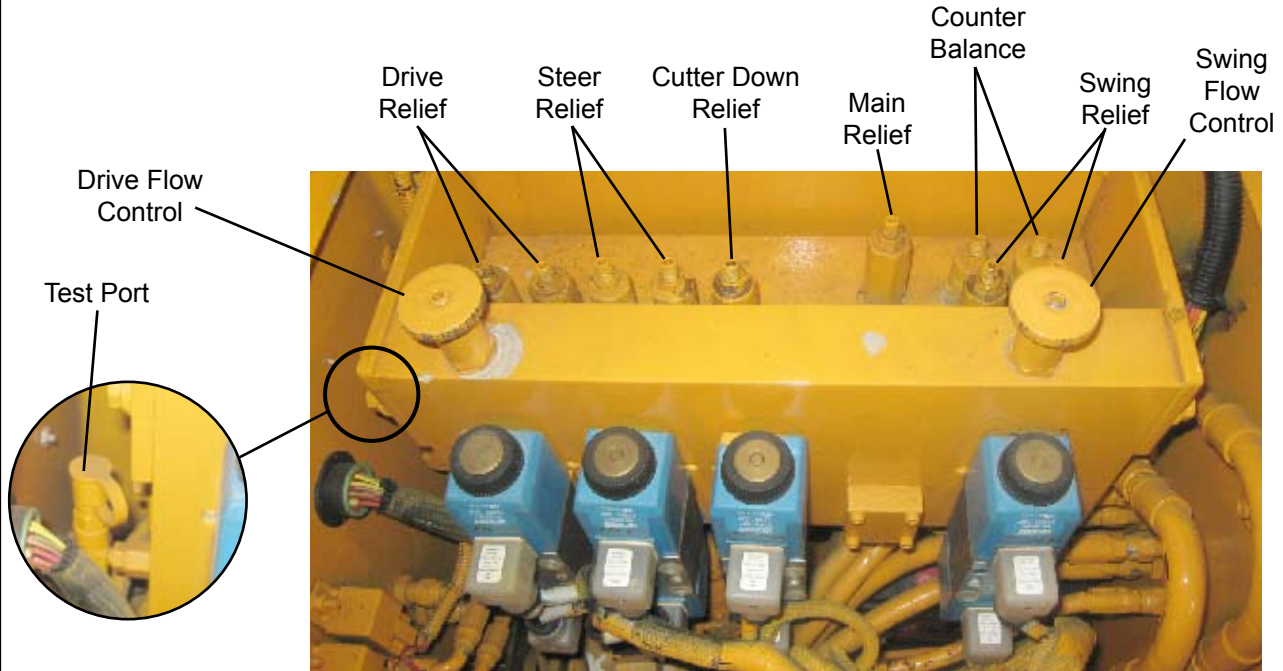

Drive Flow Control

Test Port



Drive Relief

Steer Relief

Cutter Down Relief

Main Relief

Counter Balance

Swing Relief

Swing Flow Control

NOTICE Valves may not be exactly as shown, depending on options.

Bandit

TROUBLE SHOOTING

BEFORE ATTEMPTING ANY TYPE OF MAINTENANCE DISENGAGE CLUTCH, TURN OFF ENGINE, WAIT FOR THE CUTTER WHEEL TO COME TO A COMPLETE STOP, INSTALL THE CUTTER WHEEL LOCK PIN, DISCONNECT BATTERY, AND MAKE SURE THE IGNITION KEY IS IN YOUR POSSESSION.

PROBLEM	POSSIBLE CAUSE	SOLUTION
Hydraulic oil very hot, causing system to operate slowly	<ol style="list-style-type: none"> 1. Dull teeth. 2. Low oil level. 3. Worn pump, poor oil quality. 4. Damaged hose. 5. Oil suction screen or filter plugged. 6. Binding. 	<ol style="list-style-type: none"> 1. Replace teeth. 2. Fill 7/8 full minimum. 3. Replace. 4. Replace. 5. Clean or replace. 6. Repair.
Hydraulic system loss of power.	<ol style="list-style-type: none"> 1. Low oil level. 2. Poor oil quality. 3. Bad cylinder. 4. Bad pump. 5. Bad motor. 6. Relief stuck open. 	<ol style="list-style-type: none"> 1. Fill 7/8 full minimum. 2. Replace. 3. Replace or repair. 4. Replace. 5. Replace or repair. 6. Clean or replace.
Swing cylinder loss of power.	<ol style="list-style-type: none"> 1. Cutterhead speed adjustment screw turned wide open. 2. Bad cylinder. 	<ol style="list-style-type: none"> 1. Screw in speed adjustment screw to close bypass. Readjust for "no bounce" cutting. 2. Replace or repair.
Cutter head swings faster one way than the other.	<ol style="list-style-type: none"> 1. Counter balance valve is out of adjustment. 2. Bad cylinder. 	<ol style="list-style-type: none"> 1. Adjust counter balance valve to equalize swing speed. 2. Replace or repair.
Cutter head does not stay in up position, creeps down	<ol style="list-style-type: none"> 1. Counter balance out of adjustment. 2. Bad cylinder. 	<ol style="list-style-type: none"> 1. Adjust counter balance valve or replace counter balance cartridge. 2. Replace or repair.
Cutter wheel turns while disengaged.	<ol style="list-style-type: none"> 1. Belt tension too tight. 	<ol style="list-style-type: none"> 1. Adjust belt tension, adjust belt with linkage, or slide engine towards cutter wheel.

NOTICE

When returning hydraulic components for warranty make sure to box up all warranted parts to avoid additional damage while shipping. **Do not disassemble any hydraulic components which are to be warranted.** Anything which has been disassembled or tampered with will not be warranted. Items being returned must be clean. All hydraulic components must have all hosing ports plugged. Failure to plug ports will allow debris to enter components which will void warranty.

MODEL 2150 (START 6/09) - MANUAL CONTROL HYDRAULIC SCHEMATIC

SPECIFIC SCHEMATIC FUNCTION MAY VARY
DEPENDING ON OPTIONS OR COMPONENT MANUFACTURER.

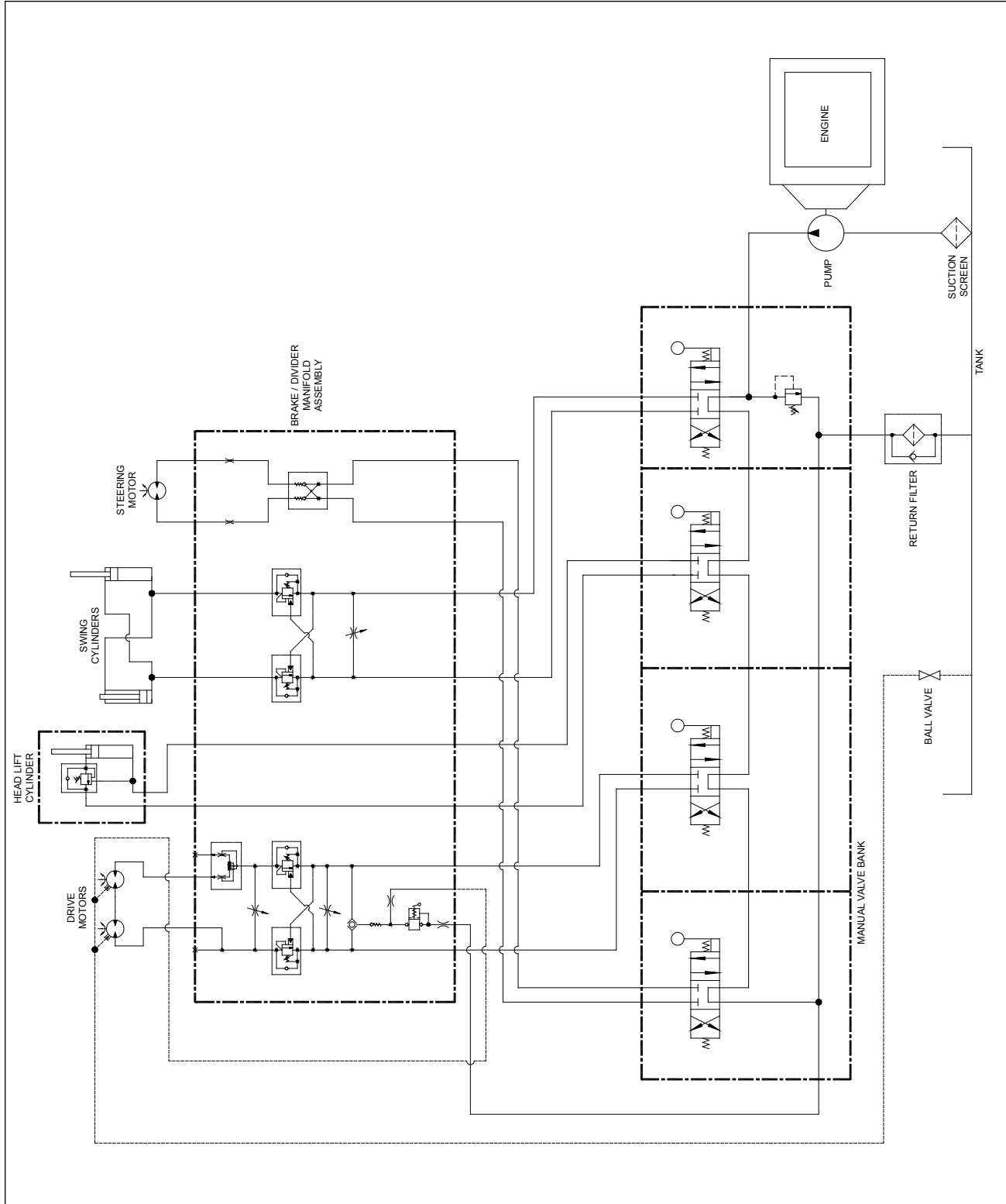

MODEL 2150 (PRE 6/09) - MANUAL CONTROL HYDRAULIC SCHEMATIC

SPECIFIC SCHEMATIC FUNCTION MAY VARY
DEPENDING ON OPTIONS OR COMPONENT MANUFACTURER.

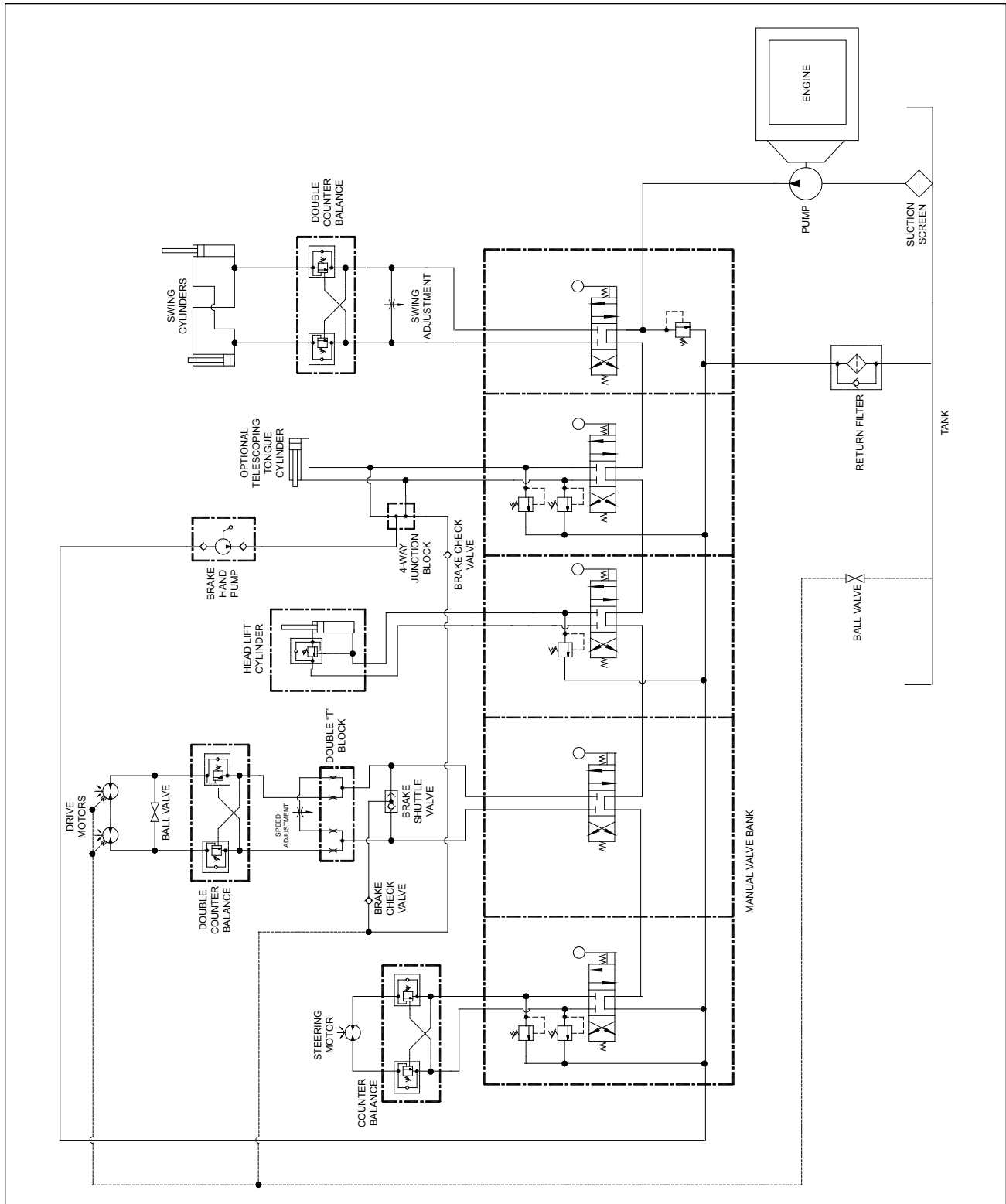

MODEL 2150 ELECTRIC CONTROL HYDRAULIC SCHEMATIC

SPECIFIC SCHEMATIC FUNCTION MAY VARY
DEPENDING ON OPTIONS OR COMPONENT MANUFACTURER.

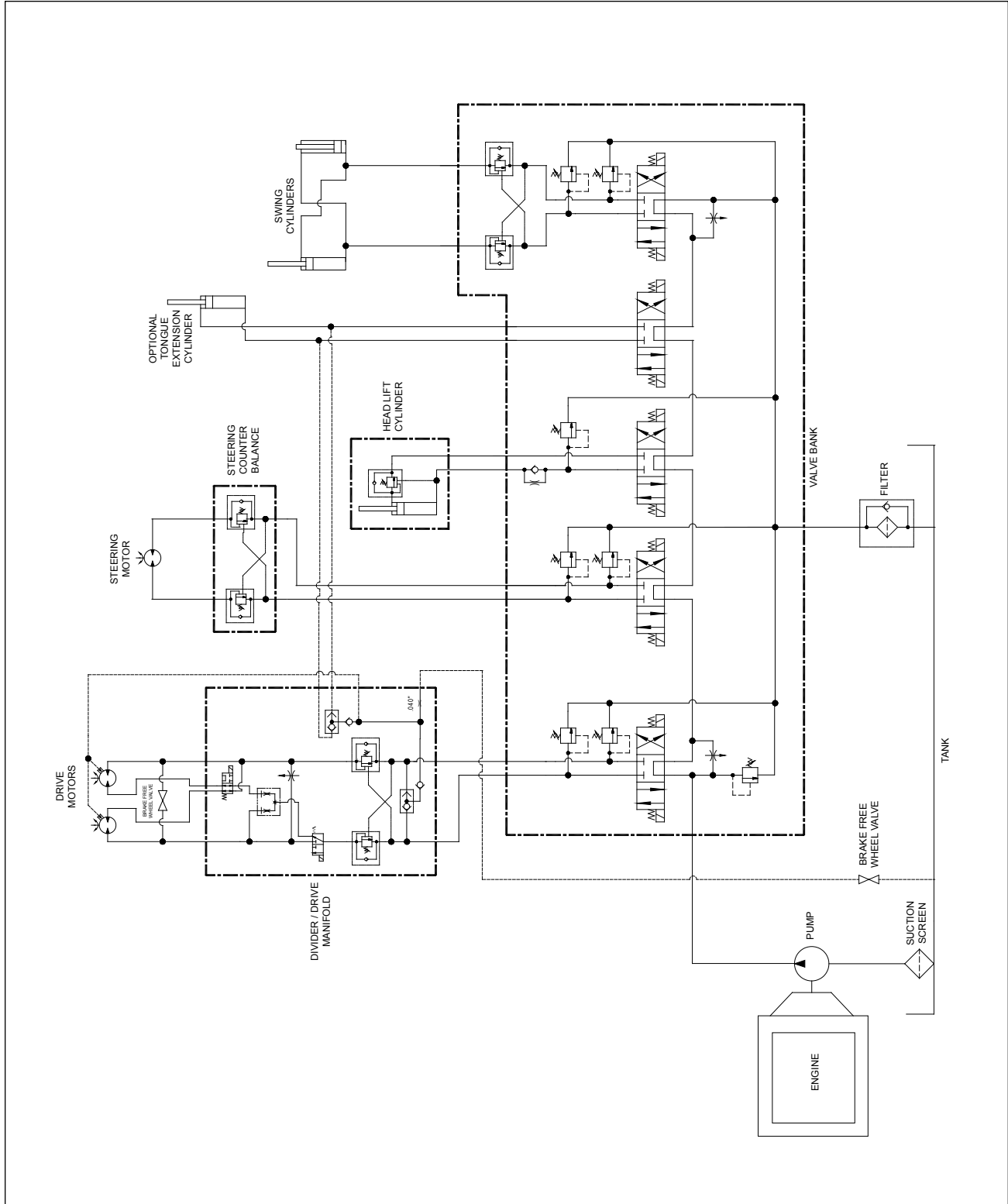

MODEL 2150 / 2450 - 4WD ELECTRIC CONTROL HYDRAULIC SCHEMATIC

SPECIFIC SCHEMATIC FUNCTION MAY VARY
DEPENDING ON OPTIONS OR COMPONENT MANUFACTURER.

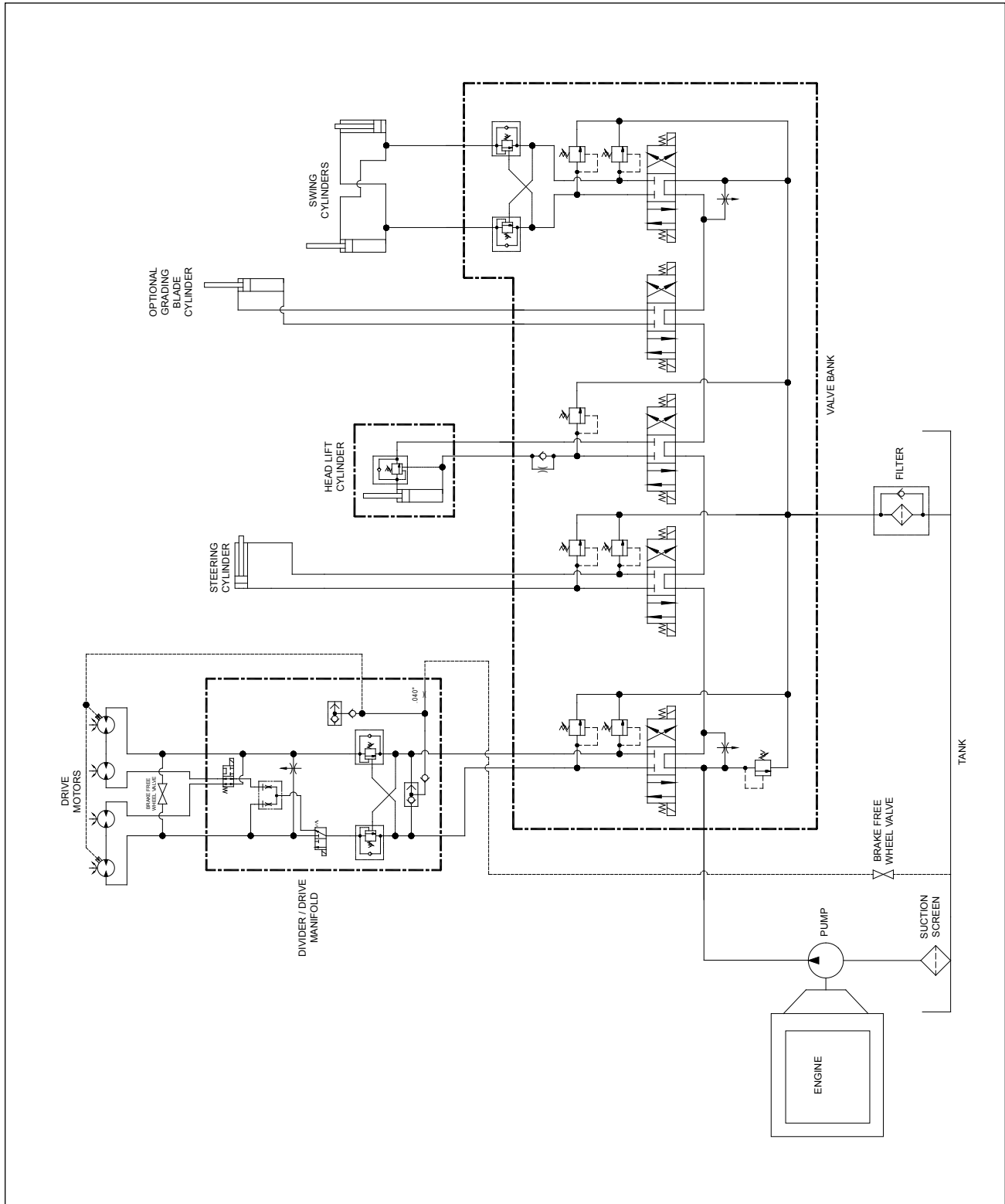

MODEL 2150 CUTTER WHEEL SECTION

DO NOT OPERATE MACHINE WITHOUT A FULL SET OF TEETH. OPERATING MACHINE WITHOUT A FULL SET OF TEETH CAN CAUSE EXCESSIVE VIBRATION AND PREMATURE BEARING FAILURE.

Use only original equipment manufacturer's teeth. The use of any other aftermarket teeth may cause damage or premature failure to the drive train.

There are eighteen (18) teeth and pockets to a complete set on a model 2150XP. Eighteen (18) teeth, six (6) straight pockets and twelve (12) angle pockets.

Do Not operate machine with extremely worn or broken teeth.

A locking pin is provided to hold the cutter wheel in position during tooth removal and installation. Locking pin will only lock on outer teeth. **NEVER USE HAND ON CUTTER WHEEL TO HOLD IN PLACE WHILE CHANGING TEETH. BE SURE TO REMOVE LOCKING PIN BEFORE OPERATING THE MACHINE.**

MODEL 2150 TOOTH ARRANGEMENT

Inspect pockets, teeth and bolts for damage and replace as required.

When replacing pockets, always replace new pockets across from each other (180°) in order to prevent vibration.

Replacement teeth must be carbide tipped and of like design as provided with the machine.

Use anti-seize on threads to help prevent bolts from "freezing up" in cutter wheel pockets.

When replacing complete set of teeth, be sure to duplicate original factory tooth arrangement. Typically a 1/2" allen key socket is required to change or torque the teeth. Torque pocket bolts to 125-150 ft.-lbs. (169-203 Nm). For Model 2150, torque tooth nut to 20-28 ft.-lbs. (27-38 Nm).

All Outside Pockets require a straight pocket mounted on each side of the cutter wheel. There are three outside pockets on each side of the cutter wheel.

All Inside Pockets require an angle pocket mounted away from the cutter wheel.

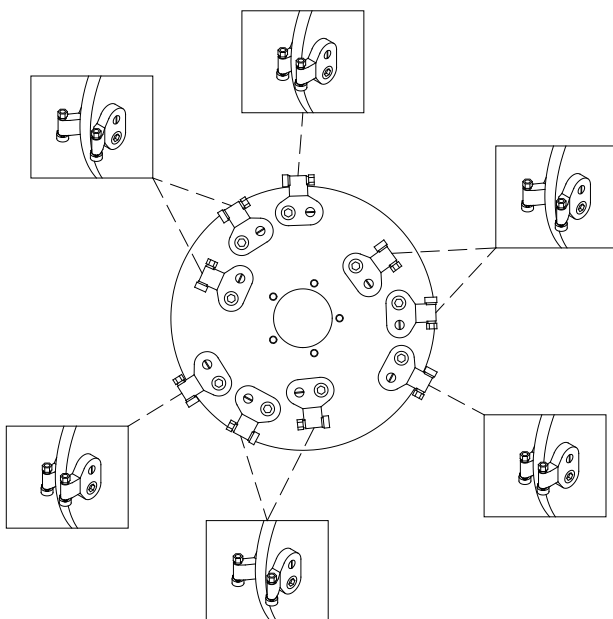

MODEL 2150XP

Green Tooth With Nut:	900-9907-76
Straight Pocket:	900-9907-05
Angle Pocket:	900-9907-04
Pocket Bolt:	900-9907-14
18 Tooth Kit:	900-9907-15

MODEL 2450 CUTTER WHEEL SECTION

DO NOT OPERATE MACHINE WITHOUT A FULL SET OF TEETH. OPERATING MACHINE WITHOUT A FULL SET OF TEETH CAN CAUSE EXCESSIVE VIBRATION AND PREMATURE BEARING FAILURE.

Use only original equipment manufacturer's teeth. The use of any other aftermarket teeth may cause damage or premature failure to the drive train.

There are eighteen (18) teeth and pockets to a complete set on a model 2450XP. Eighteen (18) teeth, six (6) straight pockets and twelve (12) angle pockets.

Do Not operate machine with extremely worn or broken teeth.

A locking pin is provided to hold the cutter wheel in position during tooth removal and installation. Locking pin will only lock on outer teeth. **NEVER USE HAND ON CUTTER WHEEL TO HOLD IN PLACE WHILE CHANGING TEETH. BE SURE TO REMOVE LOCKING PIN BEFORE OPERATING THE MACHINE.**

MODEL 2450 TOOTH ARRANGEMENT

Inspect pockets, teeth and bolts for damage and replace as required.

When replacing pockets, always replace new pockets across from each other (180°) in order to prevent vibration.

Replacement teeth must be carbide tipped and of like design as provided with the machine.

Use anti-seize on threads to help prevent bolts from "freezing up" in cutter wheel pockets.

When replacing complete set of teeth, be sure to duplicate original factory tooth arrangement. Typically a 1/2" allen key socket is required to change or torque the teeth. Torque pocket bolts to 125-150 ft.-lbs. (169-203 Nm). For Model 2450, torque tooth nut to 31-43 ft.-lbs. (42-58 Nm).

All Outside Pockets require a straight pocket mounted on each side of the cutter wheel. There are three outside pockets on each side of the cutter wheel.

All Inside Pockets require an angle pocket mounted away from the cutter wheel.

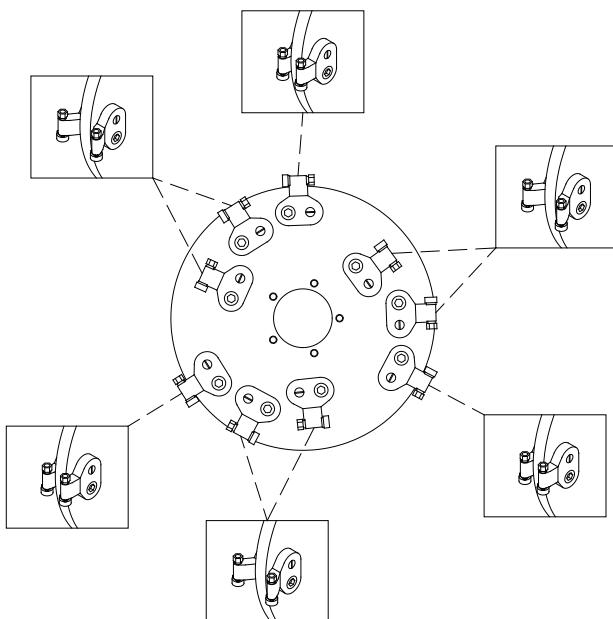

MODEL 2450XP

Green Tooth With Nut:	900-9907-92
Straight Pocket:	900-9907-87
Angle Pocket:	900-9907-86
Pocket Bolt:	900-9907-14
18 Tooth Kit:	900-9908-24

ELECTRICAL SCHEMATIC (991-8000-15) - GAS ENGINE OMNEX RADIO CONTROL MACHINE HARNESS

SPECIFIC SCHEMATIC FUNCTION MAY VARY DEPENDING
ON OPTIONS OR COMPONENT MANUFACTURER.

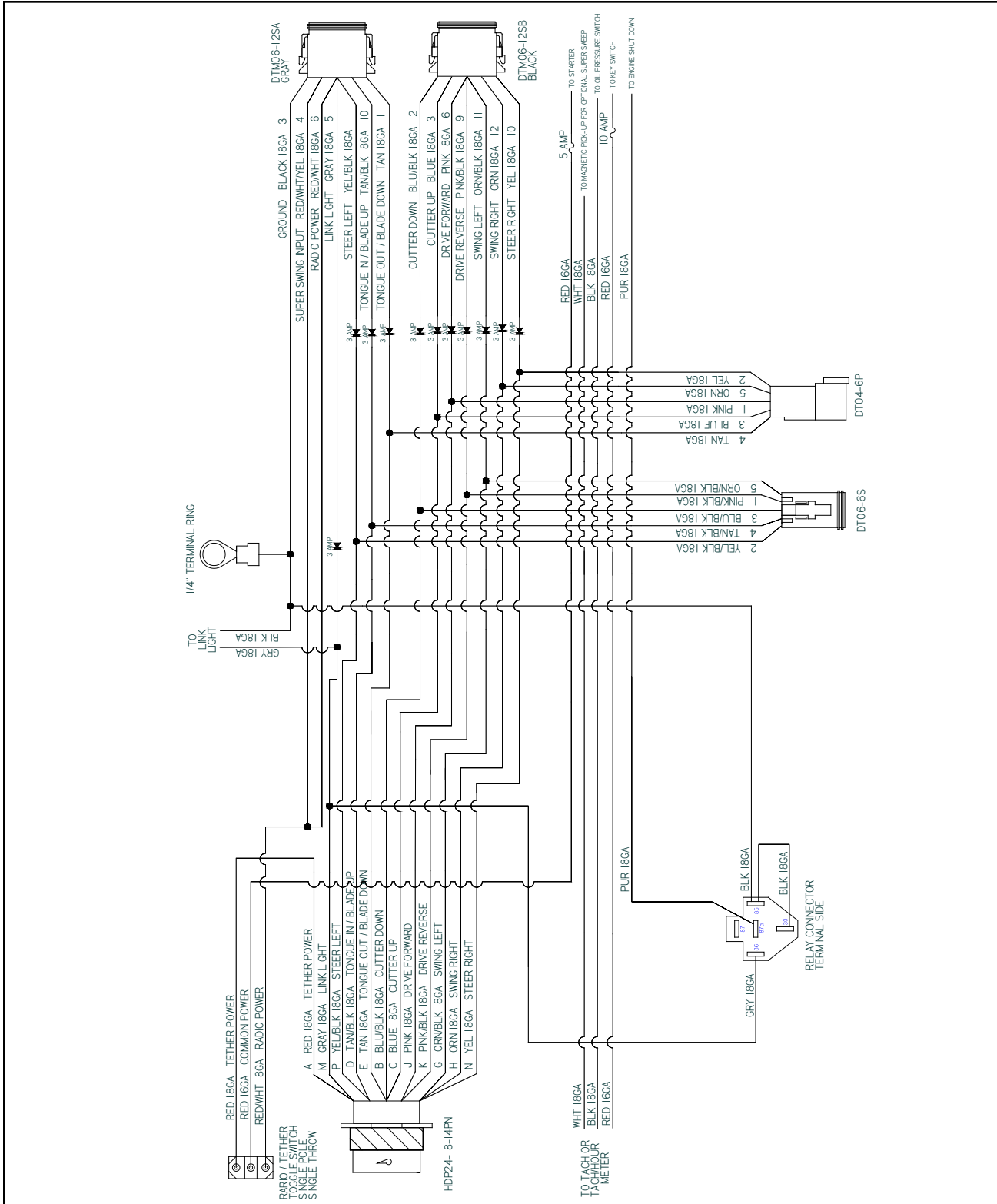

ELECTRICAL SCHEMATIC (991-8000-14) - DIESEL ENGINE OMNEX RADIO CONTROL MACHINE HARNESS

SPECIFIC SCHEMATIC FUNCTION MAY VARY DEPENDING
ON OPTIONS OR COMPONENT MANUFACTURER.

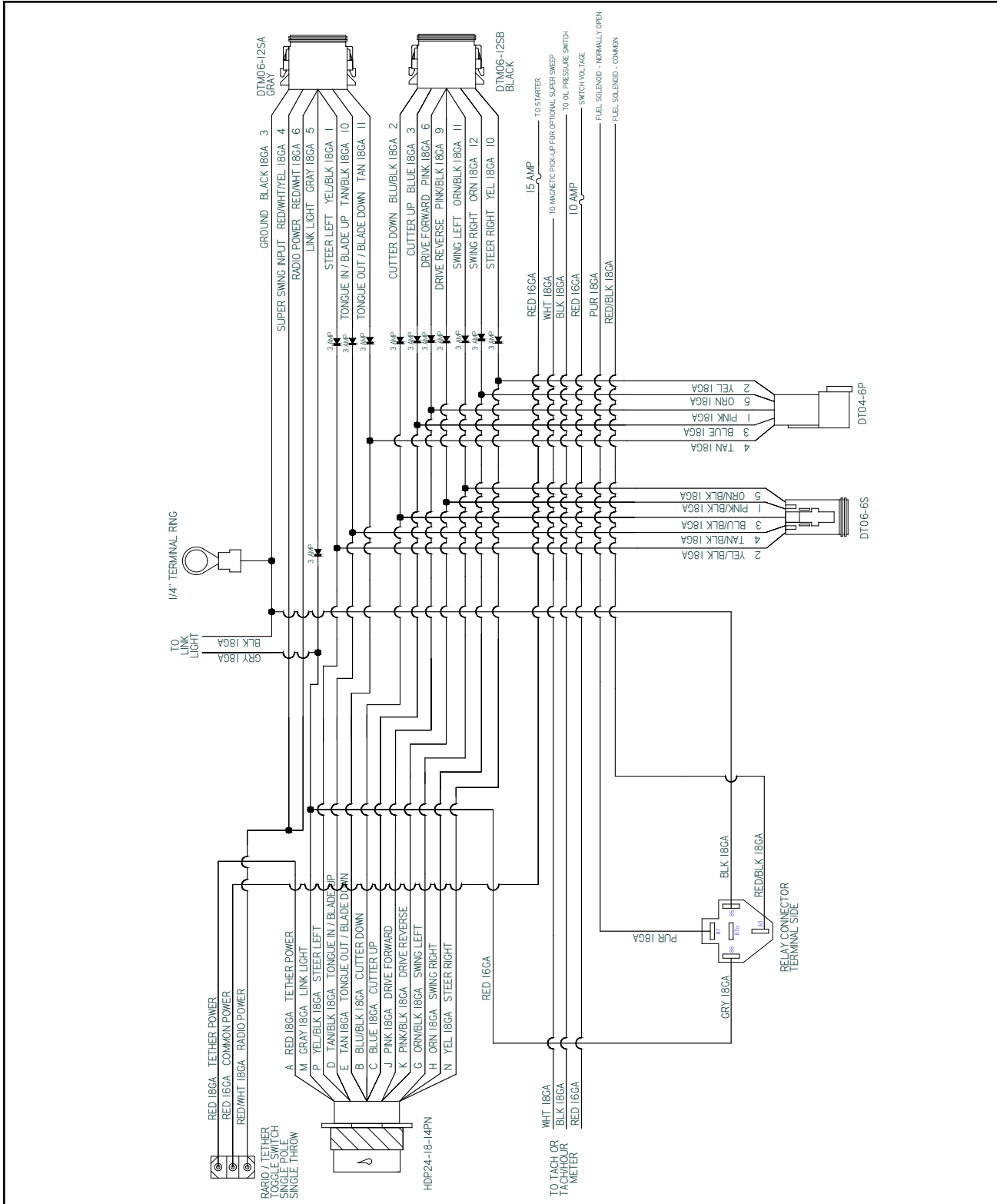

ELECTRICAL SCHEMATIC (991-8000-09)

DRIVE FORWARD VALVE HARNESS - OMNEX RADIO

SPECIFIC SCHEMATIC FUNCTION MAY VARY DEPENDING ON OPTIONS OR COMPONENT MANUFACTURER.

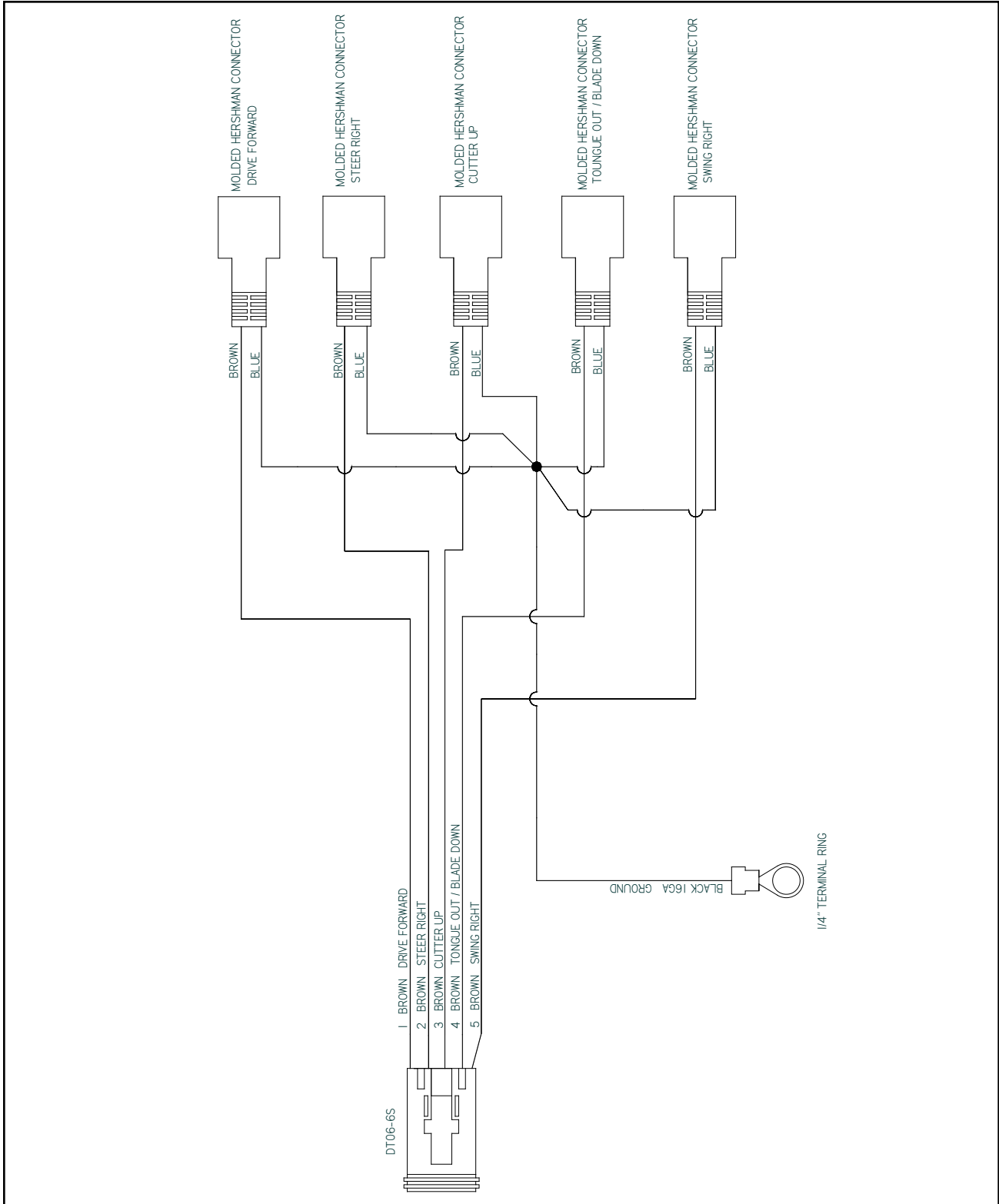

ELECTRICAL SCHEMATIC (991-8000-10)

DRIVE REVERSE VALVE HARNESS - OMNEX RADIO

SPECIFIC SCHEMATIC FUNCTION MAY VARY DEPENDING ON OPTIONS OR COMPONENT MANUFACTURER.

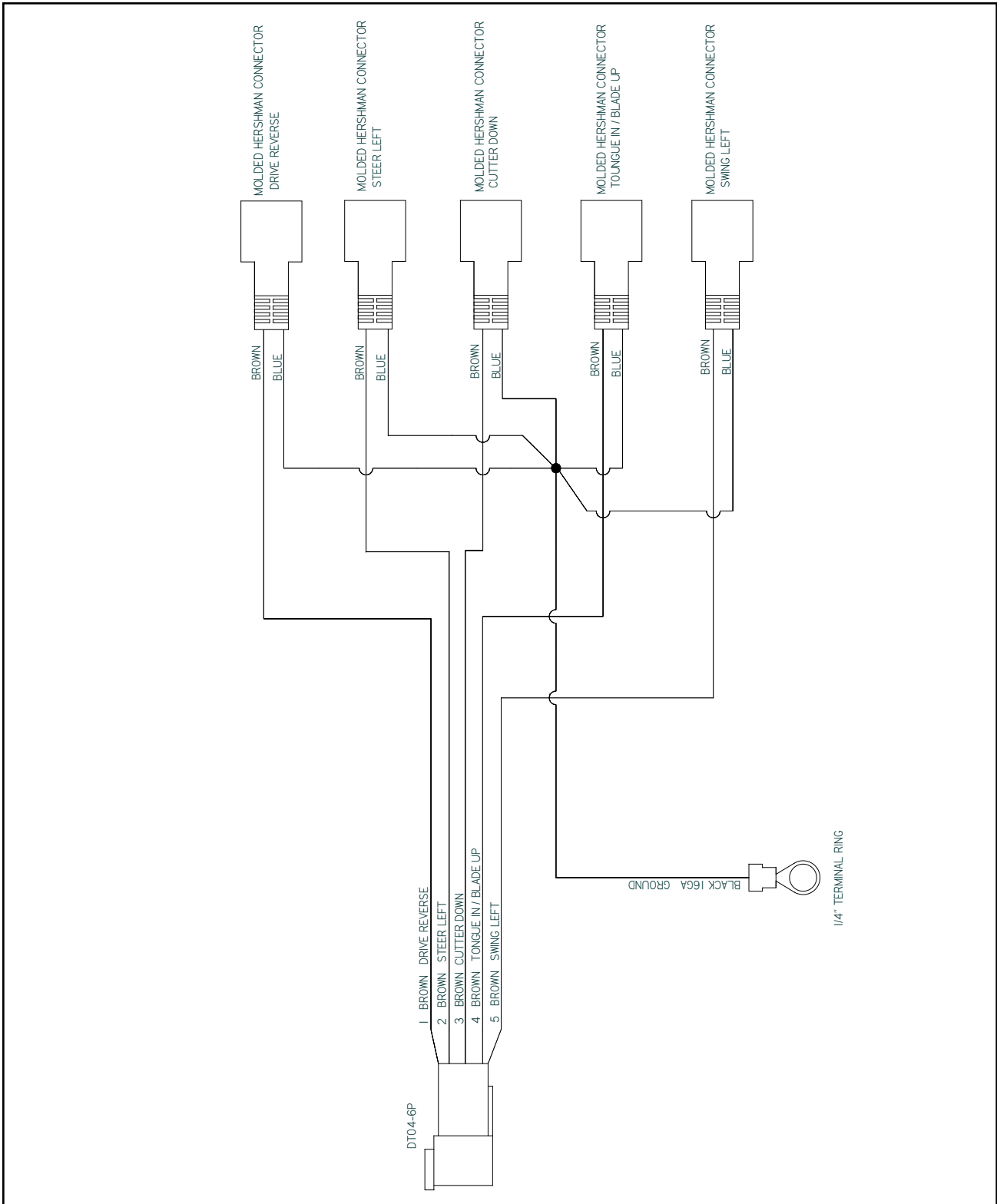

ELECTRICAL SCHEMATIC (991-8000-11) DUAL COIL SUPER SWEEP - IEC TACH

SPECIFIC SCHEMATIC FUNCTION MAY VARY DEPENDING
ON OPTIONS OR COMPONENT MANUFACTURER.

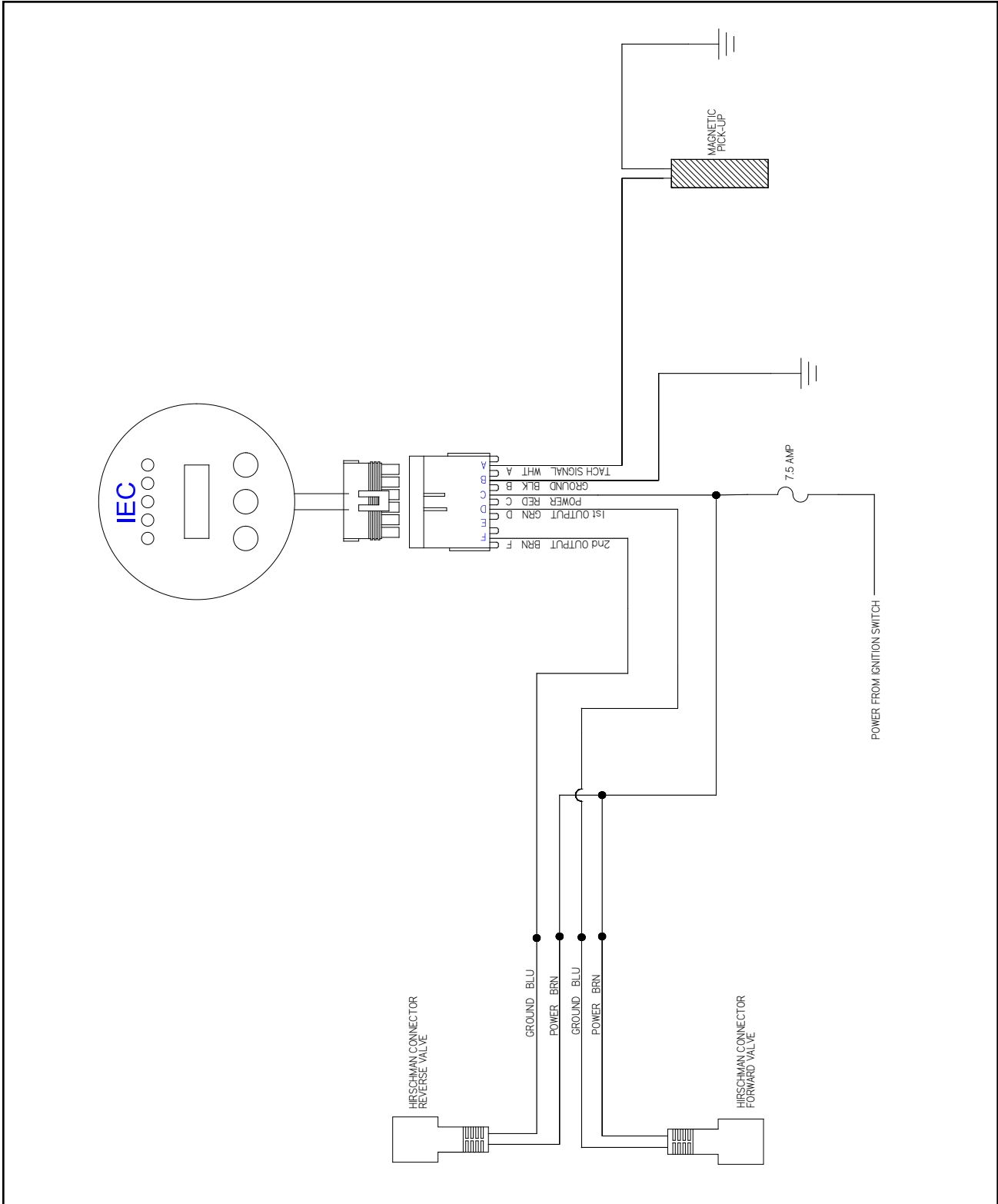

ELECTRICAL SCHEMATIC (993-8000-16) DUAL COIL SUPER SWEEP - LOR TACH

SPECIFIC SCHEMATIC FUNCTION MAY VARY DEPENDING
ON OPTIONS OR COMPONENT MANUFACTURER.

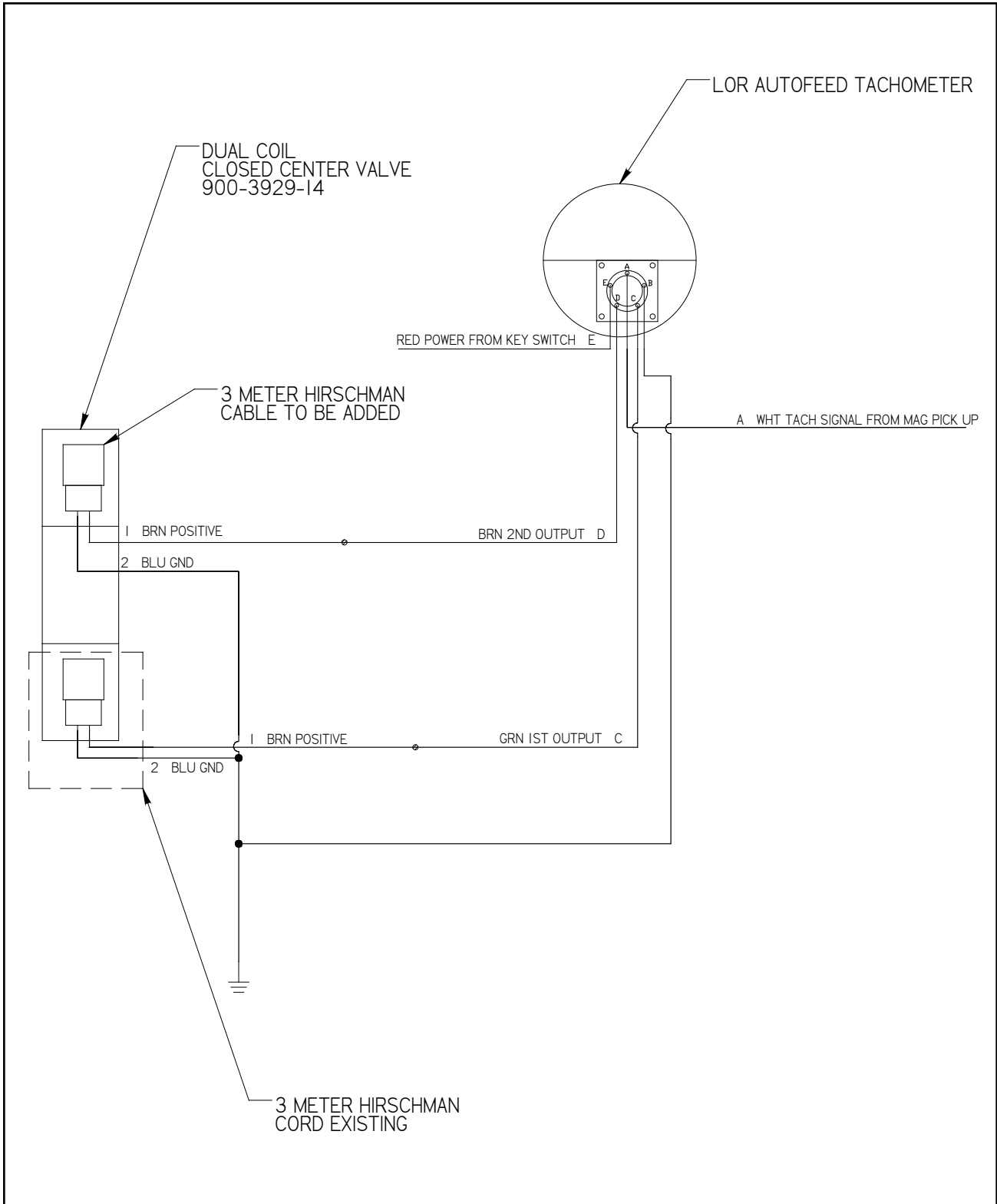

LUBRICATION & COOLANT

1) **Engine:** Follow original equipment manufacturers requirements for both changing oils and filters, refer to engine manual specifications.

2) **Engine Coolant:** Refer to engine manufacturers manual specifications.

3) **Hydraulic Reservoir Tank:** Completely change hydraulic oil, suction screen(s), and flush the tank annually. Change hydraulic oil filter AFTER FIRST 10 HOURS OF OPERATION. Then change hydraulic oil filter(s) every 400 hours or 3 months thereafter. Maintain hydraulic oil level 7/8 full. See hydraulic oil requirements below. Check hydraulic oil level in tank daily.

4) **Hydraulic Fluid Requirements:** See pages 44 - 45 for hydraulic fluid requirements.

5) **Cutter Wheel & Jack Shaft Bearings:** Use an EP-2 Lithium type grease only for all bearings. Purge cutter wheel bearings and jack shaft bearings daily with grease you can not over grease these bearings. These bearings are designed with a relief system that will not allow over greasing. In other words, you can not hurt the bearing seals by pumping in to much grease. Wipe off excess grease. **Excessive grease will attract dirt.**

Most of the failures related to bearings are diagnosed as "Contamination". Contamination is caused by improper lubrication.

Especially important is proper lubrication when the grinder is setting idle. The bearings must be fully purged when shut down. Then the bearings must be again fully purged each thirty (30) days and the machine allowed to run for approximately 10 minutes. Then fully purged again before the machine is put back into operation. Failure to do this will ruin the bearings. Bearings corrode when the machine is setting idle.

The second largest cause of bearing failure is operating them at high speeds when the grease is cold. This causes the bearing race to turn on the shaft. Naturally this ruins the bearing as well as the shaft. Allow the bearings to turn at slower speeds for at least five minutes. Also check the bearing lock collar set screws for tightness each 30 days. Loose set screws allow the race to turn on the shaft. Failed bearings diagnosed as contamination or cold starts at high speed are not covered by warranty of the bearing manufacturer.

6) **Upper Frame Pivot Bushings:** Grease upper frame pivot bushings daily with one (1) or two (2) shots of EP-2 Lithium type grease. Wipe off excess grease. **Excessive grease will attract dirt.**

7) **Swing Pivot Bearings:** Grease top and bottom cutter head swing pivot bearings weekly with one (1) shot of EP-2 Lithium type grease. Wipe off excess grease. **Excessive grease will attract dirt.**

8) **Grease Steering Axle Pivot Bushings:** Grease steering axle pivot bushings weekly. Use one (1) or two (2) shots of EP-2 Lithium type grease. Wipe off excessive grease. **Excessive grease will attract dirt.**

9) **Grease Steering Bearings:** Grease steering bearings weekly on the Model 2150. Use one (1) or two (2) shots of EP-2 Lithium type grease. Wipe off excess grease. **Excessive grease will attract dirt.**

10) **Grease Steering Bushings:** Grease steering bushings weekly on the Model 2150 with 4WD option and Model 2450. Use one (1) or two (2) shots of EP-2 Lithium type grease. Wipe off excessive grease. **Excessive grease will attract dirt.**

11) **Cylinder Lug Pin Bushings:** Grease cylinder lug pin bushings weekly. Use one (1) or two (2) shots of EP-2 Lithium type grease. Wipe off excess grease. **Excessive grease will attract dirt.**

12) **Engagement Arm Pivot:** Grease engagement arm pivot weekly. Use one (1) or two (2) shots of EP-2 Lithium type grease. Wipe off excess grease. **Excessive grease will attract dirt.**

13) **Telescopic Tongue (if equipped):** With tongue extended, grease inside tongue with one (1) to two (2) shots of an EP-2 Lithium type grease per side and spread evenly every month.

14) **Throttle Cable (if equipped):** If the machine is equipped with a manual control throttle system, lubricate inner throttle cable and cable ends with a cable lube or SAE 10W/30 type oil every month. Replace throttle cable if it doesn't operate smoothly.

15) **Outboard Bearing (Caterpillar engine):** On Caterpillar engines, grease outboard bearing behind engine sheave with one (1) to two (2) shots of an EP-2 Lithium type grease once every 6 months or 2000 hours. May need to remove the beltshield. **DO NOT OVER GREASE.**

16) **Stub Shaft Bearing (Kubota engine):** On Kubota engines, grease stub shaft bearing behind engine sheave with an EP-2 Lithium type grease once every 6 months or 2000 hours. Grease the zerk on the end of the stub shaft with two (2) to three (3) shots. Grease the zerk on the side of the stub shaft until the pin extends from the relief valve on the opposite side of the stub shaft. **DO NOT OVER GREASE.**

17) **Wheel Hub Bearings:** On Model 2150, inspect and clean wheel hub bearings, cups, and seals. Replace seals if ever removed. Grease wheel bearing with an EP-2 Lithium type grease. Remove rubber plug and pump grease into E-Z Lube zerk until all of the old grease is pumped out of the dust cap. Wipe off excess grease and replace rubber plug. **Excessive grease will attract dirt.**

REPLACEMENT PARTS SECTION

Depending on what replacement parts you are ordering the following information will be needed:

GRINDER COMPONENTS

Serial Number
Model Number of Grinder

ENGINE COMPONENTS

Brand
Engine Serial Number
Engine Spec. Number

CLUTCH COMPONENTS

Brand
Serial Number
Assembly Number of Clutch

NOTICE

When ordering any replacement parts you should have the serial number (S/N) and model of the machine to ensure that you receive the correct replacement part. See page 6 for typical serial number & work order number locations.

NOTICE

All nuts, bolts, washers, and many other components can be ordered by physical description.

NOTICE

Some of the components shown in this section are for optional equipment and may not apply to every machine.

NOTICE

Bandit Industries Inc. reserves the right to make changes in models, size, design, installations and applications on any part without notification.

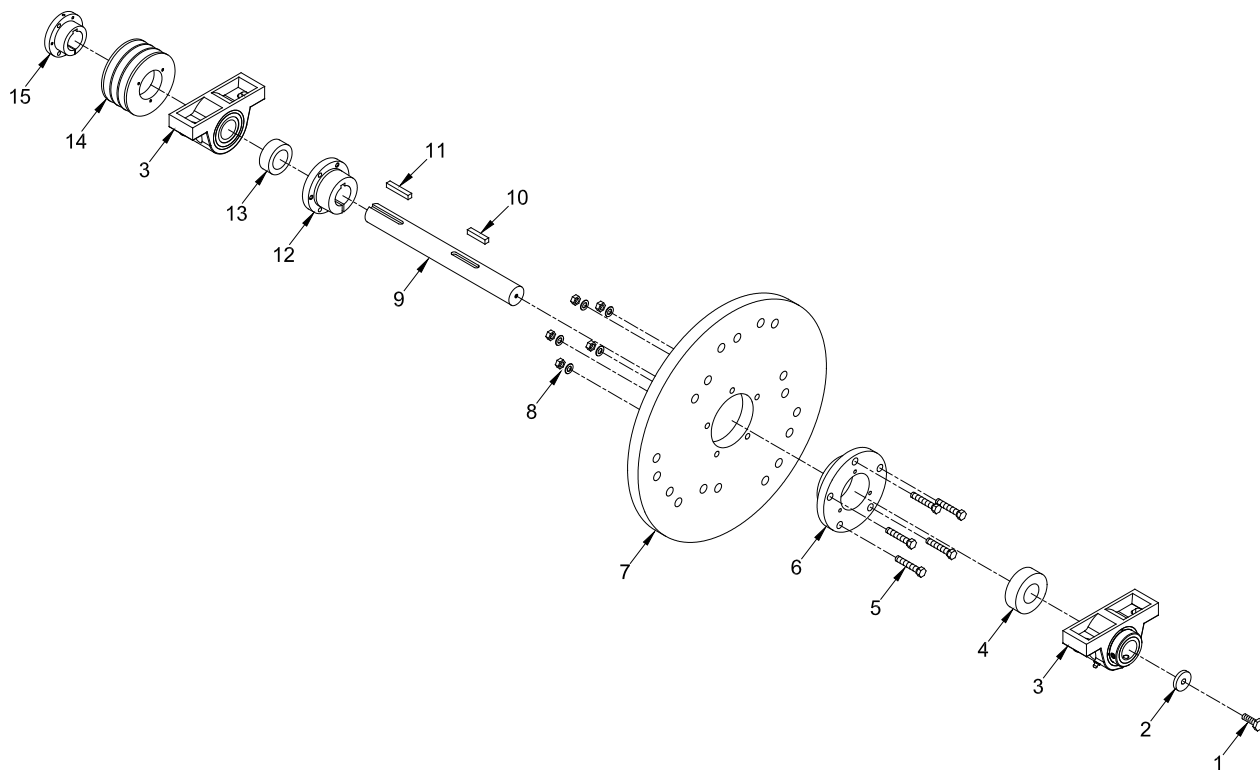

GREEN TEETH

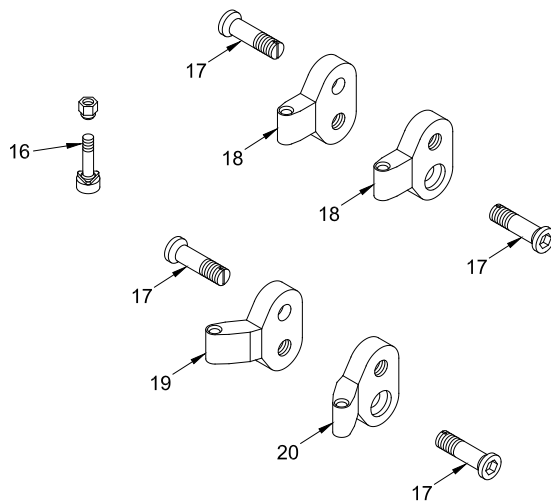

NOTICE Parts may not be exactly as shown.

Bandit

MODELS 2150XP / 2450XP**CUTTER WHEEL COMPONENTS**

LOCATION	MODEL 2150XP PART NUMBER	MODEL 2450XP PART NUMBER	DESCRIPTION
1 a.	900-4900-13	900-4900-13	3/8"-16NC x 1" Hex Head Bolt
b.	900-4906-62	900-4906-62	3/8" Lock Washer (Not Shown)
2.	900-4913-27	900-4913-27	3/8" x 1 3/4" O.D. Washer
3.	900-1914-15	900-1914-15	Cutter Wheel Bearing
4.	991-3001-19	991-3001-19	Cutter Wheel Spacer
5.	900-4903-17	900-4903-17	1/2"-13NC x 2 1/2" Hex Head Bolt (Full Thread)
6.	993-300002	993-300002	Cutter Wheel Mount Hub
7.	993-3010-72	993-3010-72	Cutter Wheel - 18 Tooth
8 a.	900-4906-84	900-4906-84	1/2" -13NC Automation Lock Nut
b.	900-4909-18	900-4909-18	1/2" Mill Carb Washer
9.	993-300003	993-300003	Cutter Wheel Shaft
10.	993-300007	993-300007	3/8" Key x 2"
11.	993-300199	993-300199	3/8" Key x 2 1/2"
12.	900-1903-36	900-1903-36	Bushing For Mount Hub
13.	200-300065	200-300065	Cutter Wheel Spacer
14 a.	900-1913-71	N/A	Sheave For V-Belt Drive
b.	N/A	900-1910-91	Sprocket For Poly Chain Belt Drive
15 a.	900-1913-72	N/A	Bushing For V-Belt Drive
b.	N/A	900-1908-15	Bushing For Poly Chain Belt Drive
16.	900-9907-76	900-9907-92	Green Tooth With Nut
17.	900-9907-14	900-9907-14	Green Bolt
18.	900-9907-05	900-9907-87	Straight Pocket
19.	900-9907-04	900-9907-86	Angle Pocket
20.	N/A	900-9907-88	Reverse Angle Pocket
21.	900-9907-15	900-9908-24	18 Green Teeth Kit - Includes Pockets & Bolts
22.	900-9904-57	900-9904-57	1/2" Allen Key Socket For 1/2" Drive (Not Shown)

NOTICE Nuts, bolts, washers, and all other components can be ordered by physical description.

Bandit

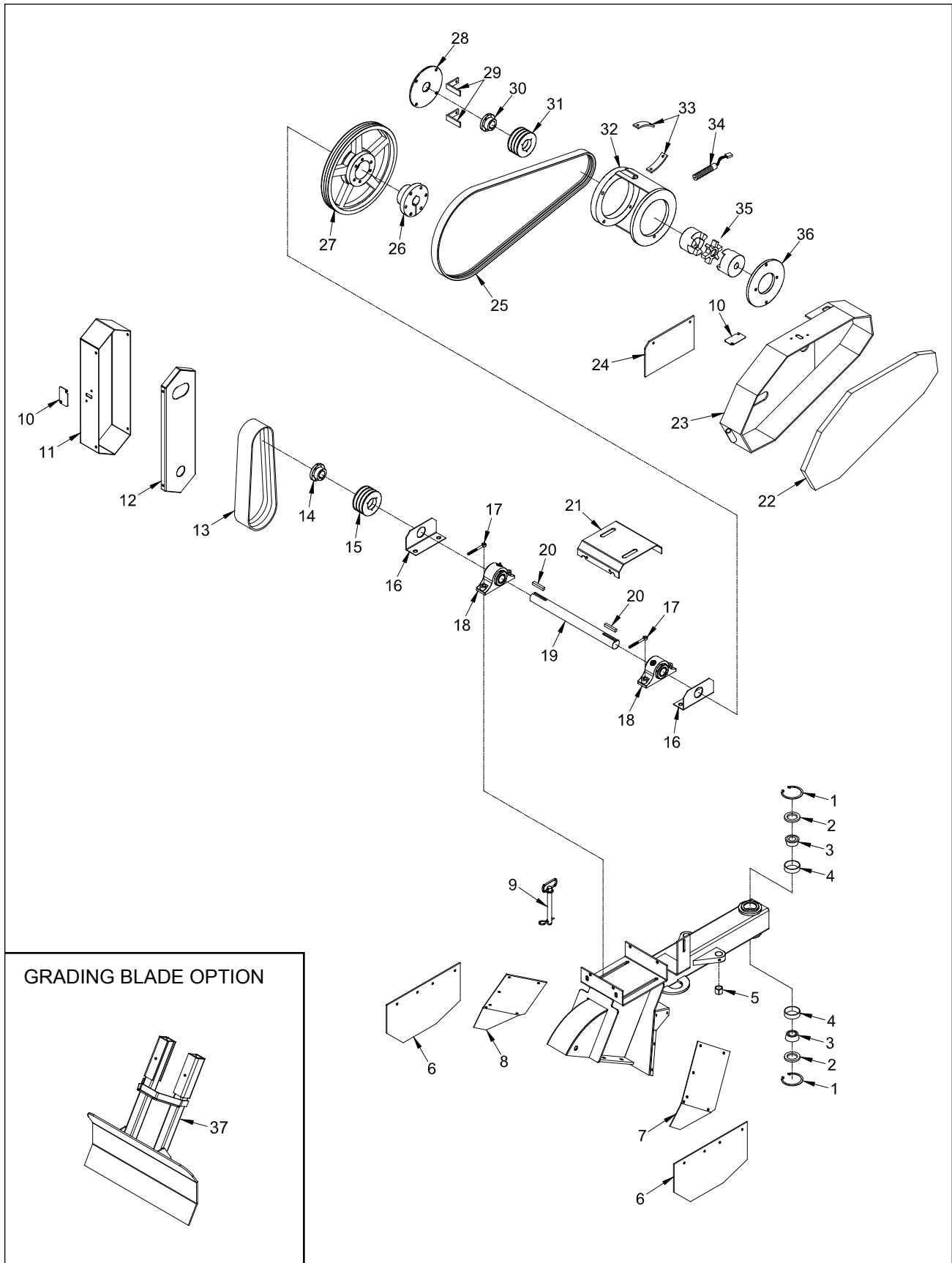

NOTICE Parts may not be exactly as shown.

Bandit

MODELS 2150XP / 2450XP**UPPER FRAME COMPONENTS**

LOCATION	MODEL 2150XP PART NUMBER	MODEL 2450XP PART NUMBER	DESCRIPTION
1.	900-1910-07	900-1910-07	Retaining Ring
2.	900-1910-01	900-1910-01	Bearing Seal
3.	900-1910-02	900-1910-02	Pivot Bearing
4.	900-1910-03	900-1910-03	Bearing Cup
5.	900-1902-42	900-1902-42	Split Bushing - 1 1/4" OD x 1" ID x 1"
6.	991-3001-91	991-3001-91	Rubber Curtain
7.	991-3001-89	991-3001-89	Cutter Head Debris Guard - Road Side
8.	991-3001-90	991-3001-90	Cutter Head Debris Guard - Curb Side
9.	900-4907-44	900-4907-44	Lock Pin
10.	989-3014-28	989-3014-28	Beltshield Slot Cover
11 a.	993-200130	993-200130	Cutter Wheel Beltshield Cover
b.	993-100140	993-100140	Cutter Wheel Beltshield Ass'y (Includes 10, 12, & 12)
12.	993-200129	993-200129	Cutter Wheel Beltshield Back
13 a.	900-1914-93	N/A	Cutter Wheel Belt
b.	N/A	900-1910-90	Poly Chain Belt
14 a.	900-1913-72	N/A	Jackshaft Sheave Bushing For Cutter Wheel Drive
b.	N/A	900-1908-15	Jackshaft Sprocket Bushing For Cutter Wheel Drive
15 a.	900-1913-71	N/A	Jackshaft Sheave For Cutter Wheel Drive
b.	N/A	900-1910-91	Jackshaft Sprocket For Cutter Wheel Drive
16.	993-300205	993-300205	Jackshaft Seal Plate
17.	900-4902-29	900-4902-29	Jackshaft Bearing Adjuster - 1/2"-13NC x 6" Eye Bolt
18.	900-1914-15	900-1914-15	Jackshaft Bearing
19 a.	993-300198	N/A	Jackshaft - Kohler / Briggs & Stratton Engine
b.	993-300202	N/A	Jackshaft - CAT Engine
c.	991-3001-77	991-3001-77	Jackshaft - Kubota Engine
20.	993-300006	993-300006	Jackshaft Key - 3/8" SQ. x 2 3/4"
21 a.	993-300197	N/A	Jackshaft Mount Cover - Kohler / Briggs & Stratton Engine
b.	993-300201	N/A	Jackshaft Mount Cover - CAT Engine
c.	991-3001-55	991-3001-55	Jackshaft Mount Cover - Kubota Engine
22 a.	991-2000-32	N/A	Engine Beltshield Cover (Start 8/09) - Kohler Engine
b.	991-1000-37	N/A	Engine Beltshield Ass'y (Start 8/09) (Includes 22) - Kohler Engine
c.	993-2001-76	N/A	Engine Beltshield Cover (Pre 8/09) - 38 Hp Kohler Engine
d.	993-1001-89	N/A	Engine Beltshield Ass'y (Pre 8/09) (Includes 22) - 38 Hp Kohler
e.	993-200055	N/A	Engine Beltshield Cover (Pre 8/09) - 27 Hp Kohler Engine
f.	993-100022	N/A	Engine Beltshield Ass'y (Pre 8/09) (Includes 22) - 27 Hp Kohler
g.	993-2001-76	N/A	Engine Beltshield Cover - Briggs & Stratton Engine
h.	993-1001-89	N/A	Engine Beltshield Ass'y (Includes 22) - Briggs & Stratton
i.	993-200056	N/A	Engine Beltshield Cover - CAT Engine
j.	993-100074	N/A	Engine Beltshield Ass'y (Includes 22) - CAT Engine
k.	991-2000-41	991-2000-41	Engine Beltshield Cover - Kubota Engine
l.	991-1000-49	991-1000-49	Engine Beltshield Ass'y (Includes 22) - Kubota Engine
23 a.	991-2000-31	N/A	Engine Beltshield Back (Start 8/09) - Kohler Engine
b.	993-2001-77	N/A	Engine Beltshield Back (Pre 8/09) - 38 Hp Kohler Engine
c.	993-200054	N/A	Engine Beltshield Back (Pre 8/09) - 27 Hp Kohler Engine
d.	993-200057	N/A	Engine Beltshield Back - CAT Engine
e.	991-2000-40	991-2000-40	Engine Beltshield Back - Kubota Engine
24 a.	993-300197	N/A	Beltshield Engagement Cover - Kohler / Briggs & Stratton
b.	993-3011-80	N/A	Beltshield Engagement Cover - CAT Engine
c.	991-3001-55	991-3001-55	Beltshield Engagement Cover - Kubota Engine

NOTICE Nuts, bolts, washers, and all other components can be ordered by physical description.

Bandit

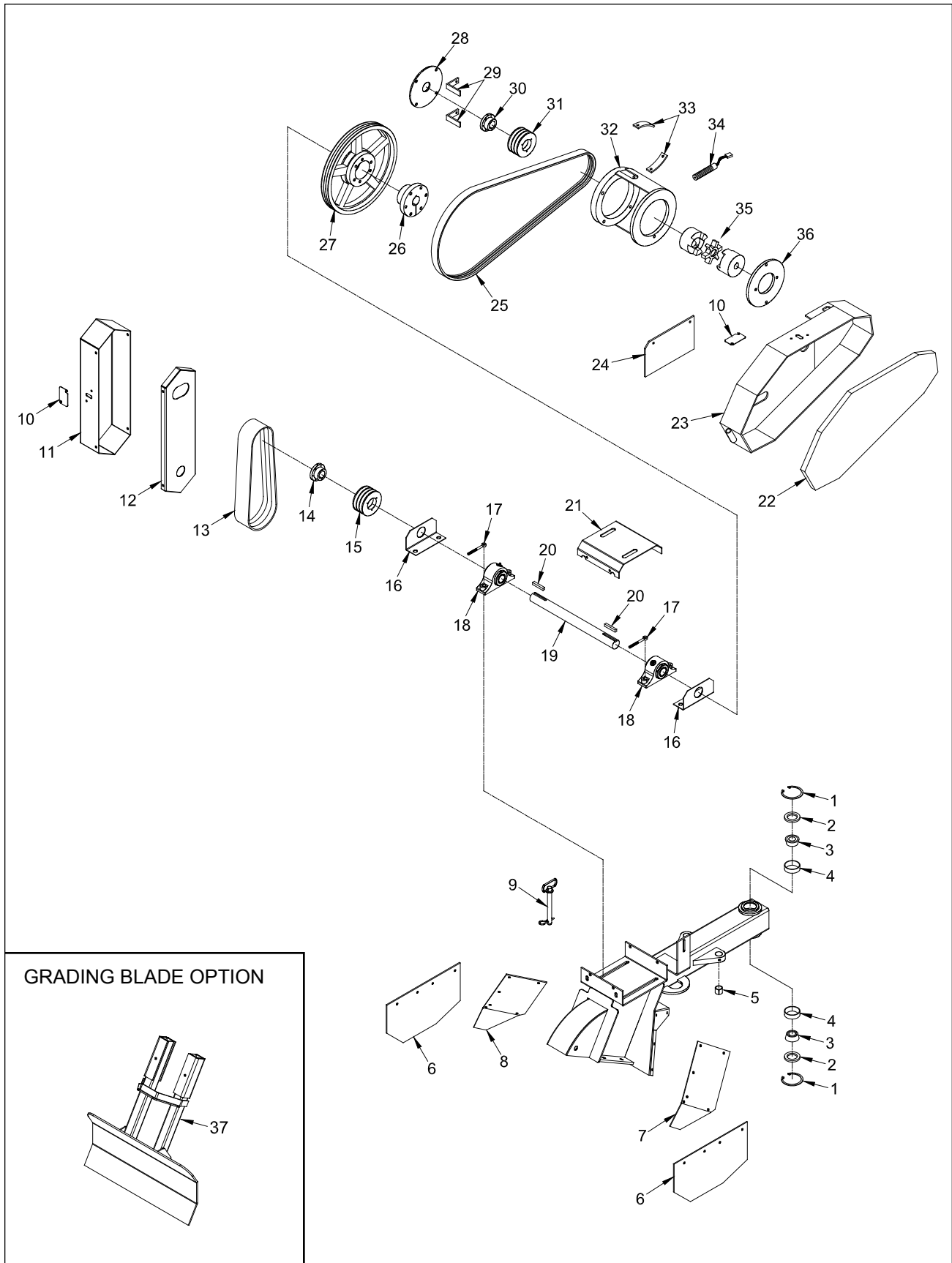

NOTICE Parts may not be exactly as shown.

Bandit

MODELS 2150XP / 2450XP**UPPER FRAME COMPONENTS**

LOCATION	MODEL 2150XP PART NUMBER	MODEL 2450XP PART NUMBER	DESCRIPTION
25 a.	900-1912-19	N/A	Engine Belt - Kohler Engine
b.	900-1912-19	N/A	Engine Belt - Briggs & Stratton Engine
c.	900-1912-76	N/A	Engine Belt - CAT Engine
d.	900-1912-19	900-1912-19	Engine Belt - Kubota Engine
26 a.	900-1903-36	N/A	Jackshaft Bushing For Engine Drive - 27 Hp Kohler Engine
b.	900-1909-19	N/A	Jackshaft Bushing For Engine Drive - 38 Hp Kohler Engine
c.	900-1909-19	N/A	Jackshaft Bushing For Engine Drive - Briggs & Stratton
d.	900-1909-19	N/A	Jackshaft Bushing For Engine Drive - CAT Engine
e.	900-1909-19	900-1909-19	Jackshaft Bushing For Engine Drive - Kubota Engine
27 a.	900-1908-61	N/A	Jackshaft Sheave For Engine Drive - 27 Hp Kohler Engine
b.	900-1911-76	N/A	Jackshaft Sheave For Engine Drive - 38 Hp Kohler Engine
c.	900-1911-76	N/A	Jackshaft Sheave For Engine Drive - Briggs & Stratton Engine
d.	900-1909-18	N/A	Jackshaft Sheave For Engine Drive - CAT Engine
e.	900-1903-41	900-1903-41	Jackshaft Sheave For Engine Drive - Kubota Engine
28 a.	993-300241	N/A	Engine Plate For Hydraulic Pump Mount - Kohler (Pre 8/09)
b.	993-300241	N/A	Engine Plate For Hydraulic Pump Mount - Briggs & Stratton
29 a.	993-300245	N/A	Belt Guide (Long) - Engine Sheave - Kohler / Briggs & Stratton
b.	991-3001-82	N/A	Belt Guide (Short) - Engine Sheave - Kohler / Briggs & Stratton
c.	993-300190	N/A	Belt Guide - Engine Sheave - CAT Engine
d.	991-3001-82	991-3001-82	Belt Guide - Engine Sheave - Kubota Engine
30 a.	900-1908-60	N/A	Engine Sheave Bushing - 27 Hp Kohler Engine
b.	900-1903-13	N/A	Engine Sheave Bushing - 38 Hp Kohler Engine
c.	900-1903-13	N/A	Engine Sheave Bushing - Briggs & Stratton Engine
d.	900-1903-86	N/A	Engine Sheave Bushing - CAT Engine
e.	900-1909-19	900-1909-19	Engine Sheave Bushing - Kubota Engine
31 a.	900-1908-59	N/A	Engine Sheave - 27 Hp Kohler Engine
b.	900-1909-16	N/A	Engine Sheave - 38 Hp Kohler Engine
c.	900-1909-16	N/A	Engine Sheave - Briggs & Stratton Engine
d.	900-1909-16	N/A	Engine Sheave - CAT Engine
e.	900-1911-76	900-1911-76	Engine Sheave - Kubota Engine
32 a.	900-6910-79	N/A	Pump Mount - Kohler Engine (Pre 8/09)
b.	900-6910-78	N/A	Pump Mount - Briggs & Stratton Engine
c.	993-100139	N/A	Pump Mount (29" Wide Machine) (Pre 8/09)
33.	993-3008-91	N/A	Pump Mount Cover
34.	900-2914-80	900-2914-80	Magnetic Pick-Up
35 a.	900-1915-59	N/A	Pump Coupler Assembly - Kohler Engine (Pre 8/09)
b.	900-1915-59	N/A	Pump Coupler Assembly - Briggs & Stratton Engine
c.	900-1915-84	N/A	Pump Coupler Body Only (29" Wide Machine) (Pre 8/09)
d.	900-1915-85	N/A	Pump Coupler Spider Only (29" Wide Machine) (Pre 8/09)
36 a.	993-300243	N/A	Hydraulic Pump Mount Plate - Kohler Engine (Pre 8/09)
b.	993-300243	N/A	Hydraulic Pump Mount Plate - Briggs & Stratton
37.	991-2000-44	N/A	Optional Grading Blade Assembly

NOTICE Nuts, bolts, washers, and all other components can be ordered by physical description.

Bandit

KOHLER / BRIGGS & STRATTON (VANGUARD) ENGINE

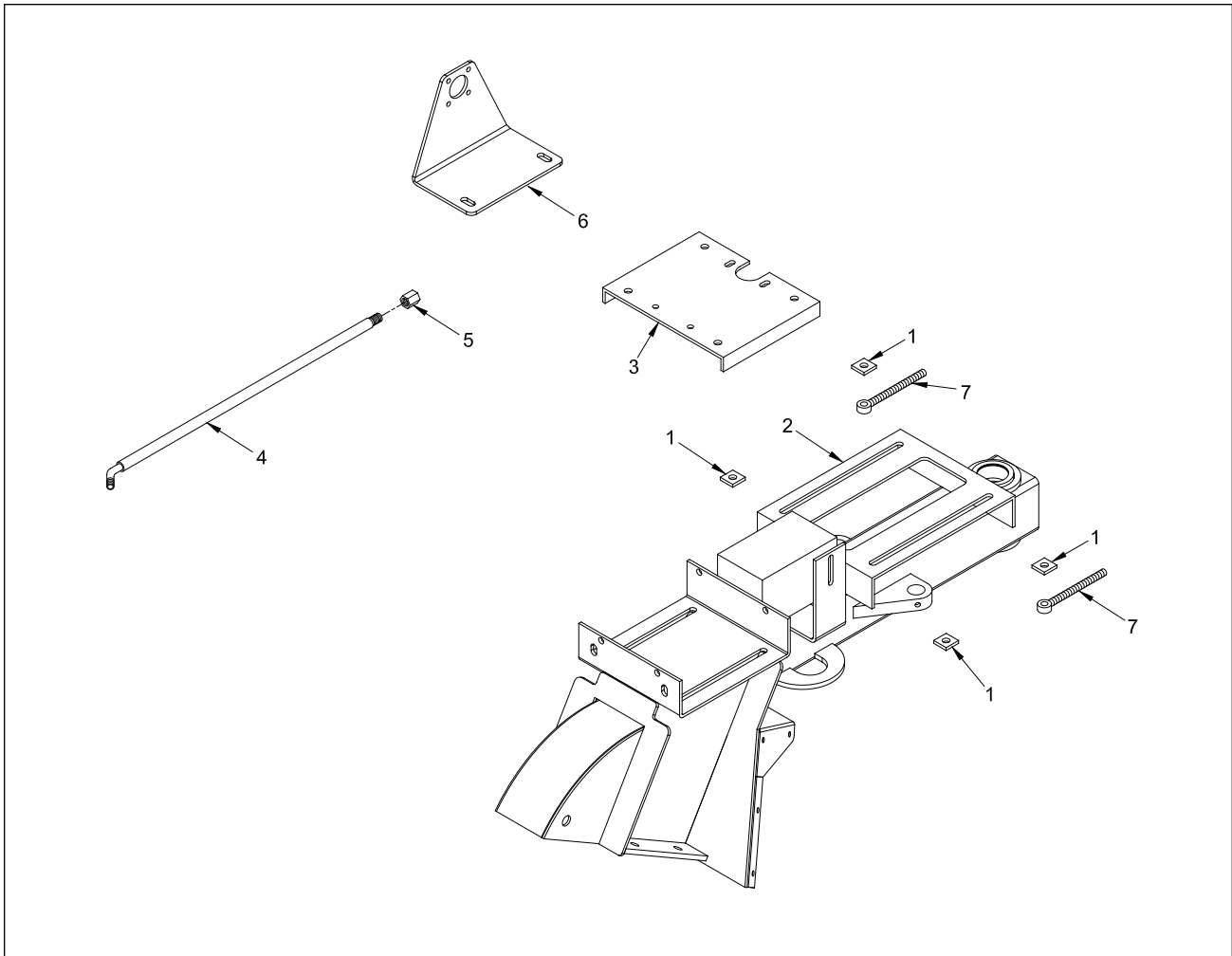

LOCATION	PART NUMBER	DESCRIPTION
1.	993-300077	Engine Mount Washer
2 a.	993-300074	Kohler Engine Mount
b.	993-300494	Briggs & Stratton Engine Mount
3 a.	993-300076	Kohler Engine Plate
b.	993-300495	Briggs & Stratton Engine Plate
4.	900-3937-80	Engine Oil Drain Hose
5.	900-3936-41	Cap For Engine Oil Drain Hose
6 a.	991-2000-28	Pump Mount - 27 Hp Kohler Engine
b.	991-2000-47	Pump Mount - 38 Hp Kohler Engine
c.	991-2000-33	Pump Mount - Briggs & Stratton Engine
7.	900-4907-91	1/2"-13NC x 4 1/2" Eye Bolt - Engine Adjuster
8 a.	993-800009	Positive Battery Cable - Kohler / Briggs & Stratton (Not Shown)
b.	993-800010	Negative Battery Cable - Kohler / Briggs & Stratton (Not Shown)

NOTICE Nuts, bolts, washers, and all other components can be ordered by physical description.

NOTICE Parts may not be exactly as shown.

CAT / KUBOTA ENGINE

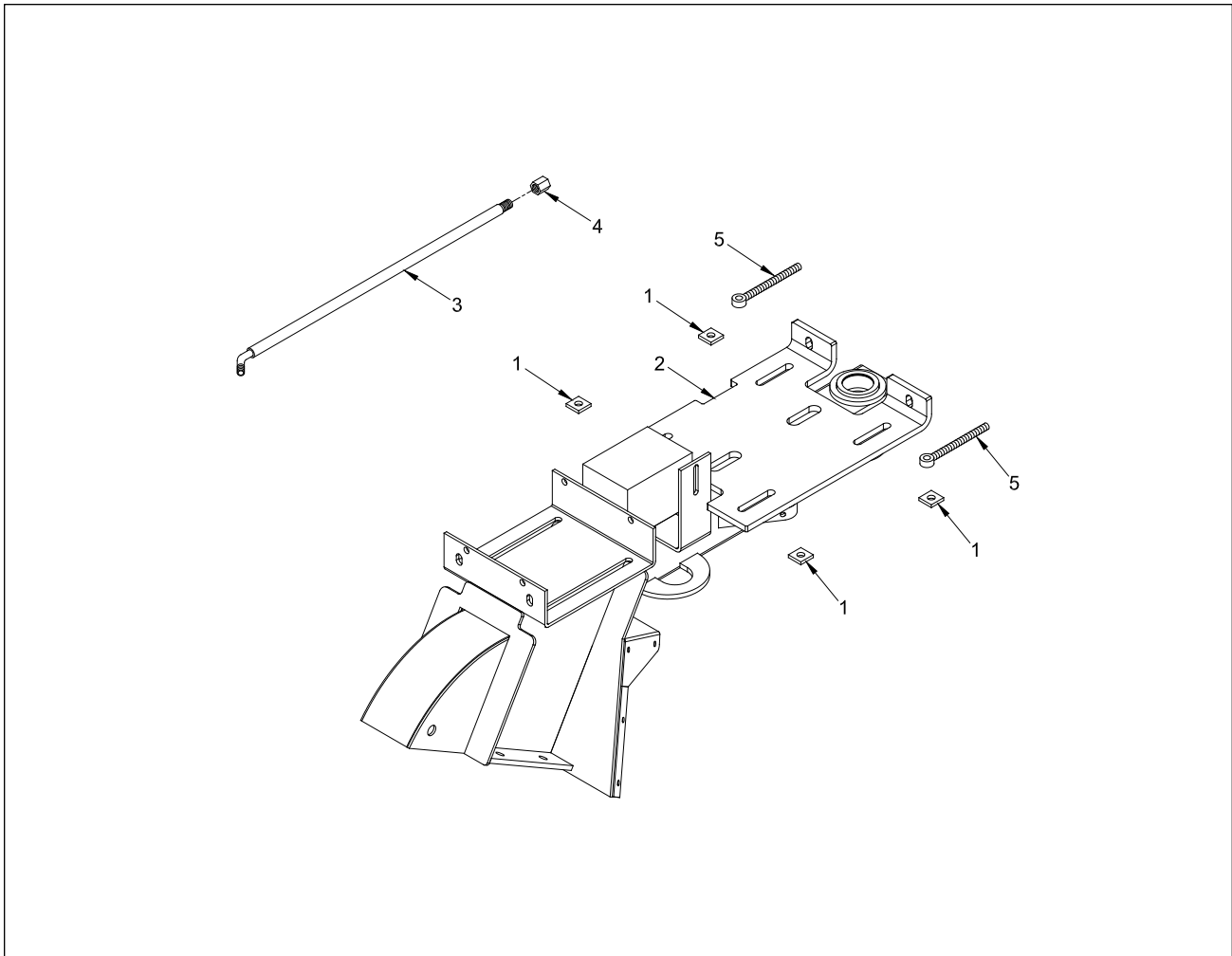

LOCATION	MODEL 2150XP PART NUMBER	MODEL 2450XP PART NUMBER	DESCRIPTION
1.	993-300077	993-300077	Engine Mount Washer
2 a.	993-300634	N/A	CAT Engine Mount Plate
b.	993-3010-89	993-3010-88	Kubota Engine Mount
3.	900-3937-80	900-3937-80	Engine Oil Drain Hose
4.	900-3936-41	900-3936-41	Cap For Engine Oil Drain Hose
5.	900-4907-91	900-4907-91	1/2"-13NC x 4 1/2" Eye Bolt - Engine Adjuster
6 a.	993-8000-12	N/A	Positive Battery Cable - CAT (Not Shown)
b.	993-8000-13	N/A	Negative Battery Cable - CAT (Not Shown)
c.	991-8000-12	991-8000-12	Positive Battery Cable - Kubota (Not Shown)
d.	991-8000-13	991-8000-13	Negative Battery Cable - Kubota (Not Shown)

NOTICE Nuts, bolts, washers, and all other components can be ordered by physical description.

NOTICE Parts may not be exactly as shown.

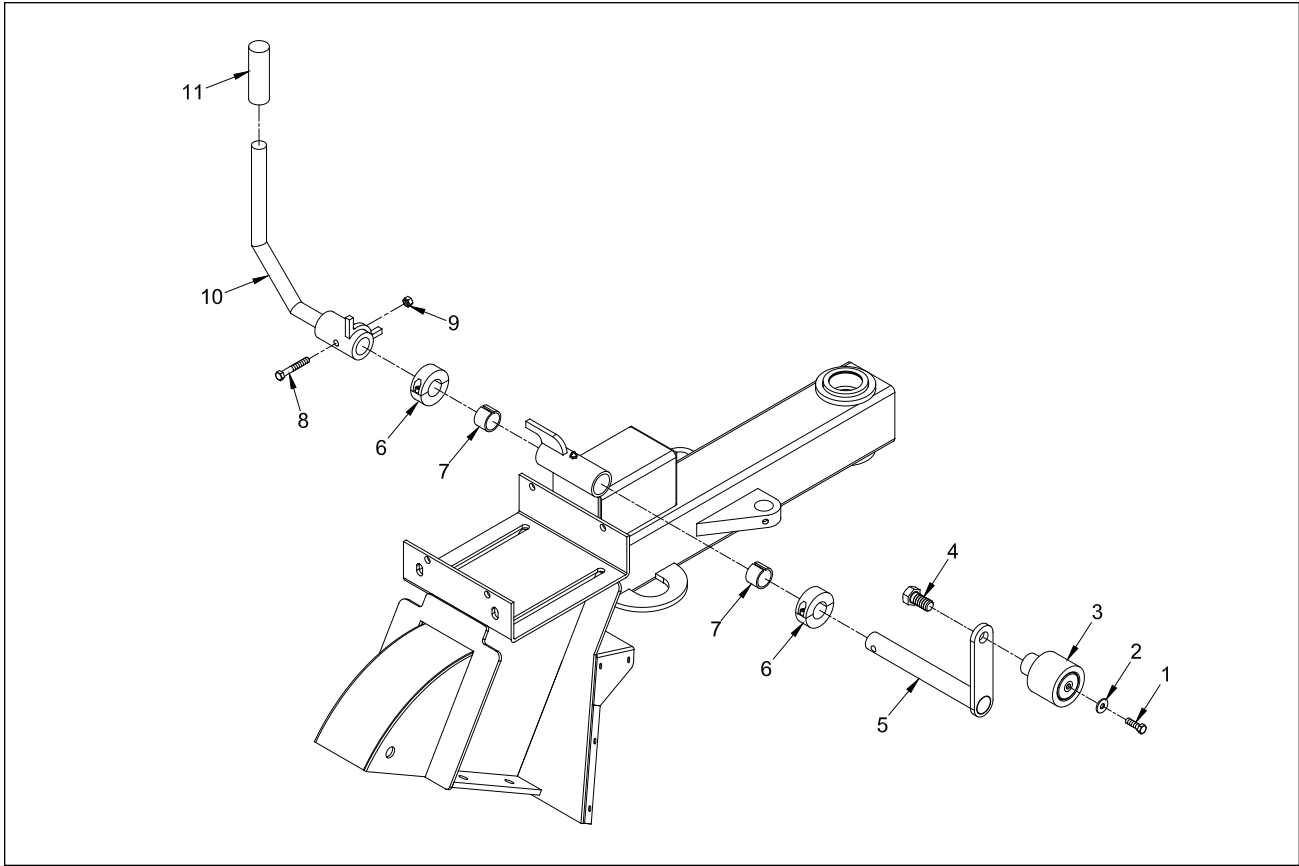

LOCATION	PART NUMBER	DESCRIPTION
1.	900-4900-13	3/8"-16NC x 1" Hex Head Bolt
2 a.	900-4906-65	3/8" Flat Washer
b.	900-4906-62	3/8" Lock Washer (Not Shown)
3.	900-1913-12	Idler Pulley Assembly (Pulley & Shaft)
4 a.	900-4910-21	3/4"-10NC x 1 1/2" Hex Head Bolt
b.	900-4907-17	3/4" Lock Washer (Not Shown)
5 a.	993-3010-76	Engagement Shaft - Kohler / Briggs & Stratton
b.	993-3010-58	Engagement Shaft - Caterpillar
c.	993-3011-07	Engagement Shaft - Kubota
6.	900-4914-51	Split Lock Collar - 1 1/4" ID
7.	900-1912-57	Split Bushing - 1 1/2" OD x 1 1/4" ID x 1"
8.	900-4903-62	3/8"-16NC x 2 1/2" Hex Head Bolt
9.	900-4900-62	3/8"-16NC Hex Nut
10 a.	993-3010-78	Engagement Handle - Kohler / Briggs & Stratton
b.	993-3010-62	Engagement Handle - Caterpillar
c.	993-3010-78	Engagement Handle - Kubota
11.	900-4907-35	Handle Grip

NOTICE Nuts, bolts, washers, and all other components can be ordered by physical description.

NOTICE Parts may not be exactly as shown.

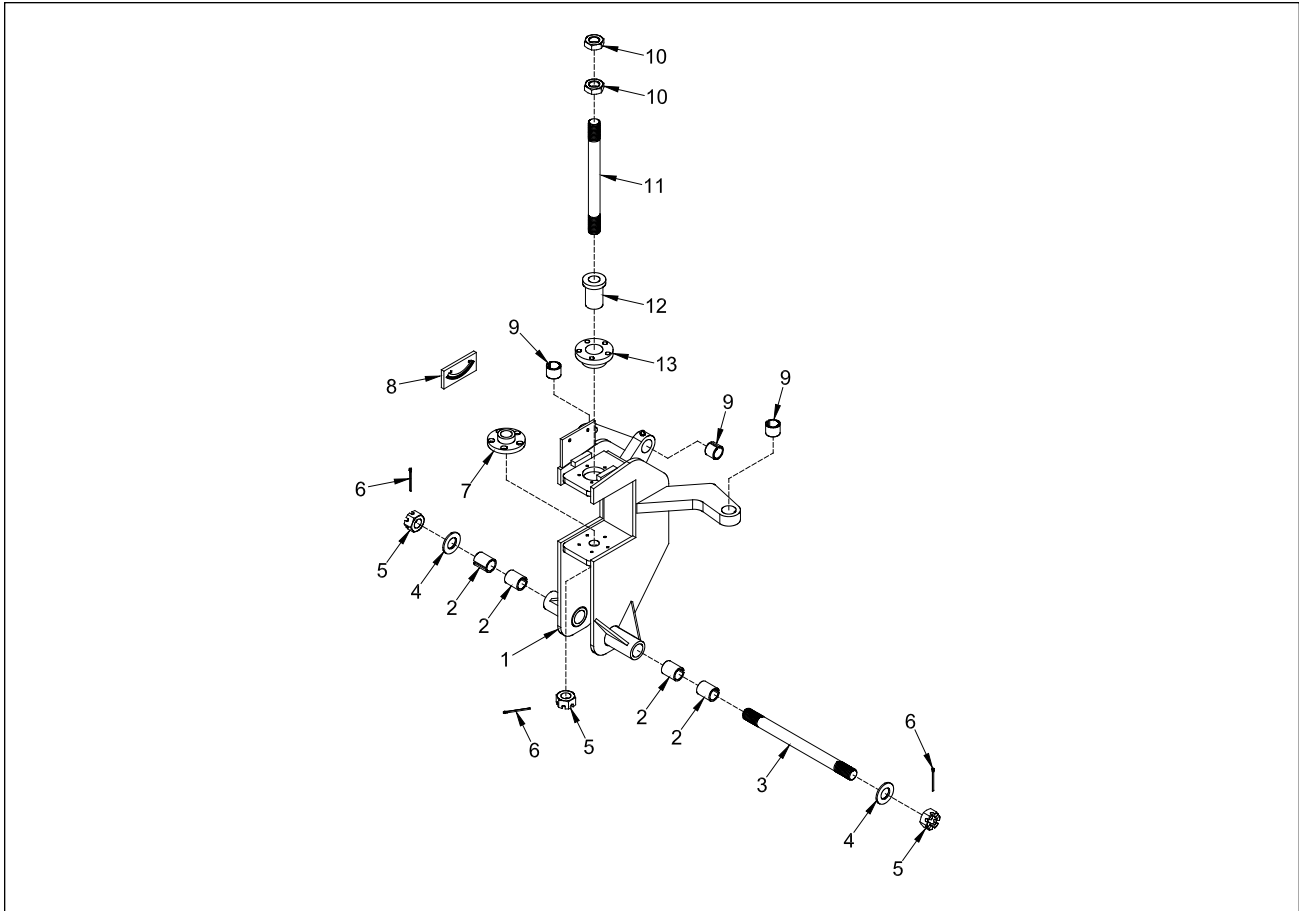

LOCATION	PART NUMBER	DESCRIPTION
1.	991-1000-50	Pivot Assembly (Includes 1 - 13)
2.	900-1902-50	Split Bushing - 1 1/4" OD x 1" ID x 1 1/2"
3.	993-300065	Up & Down Pivot Pin
4.	900-4900-79	1" USS Washer
5.	900-4909-08	1"-8NC Slotted Hex Nut
6.	900-4911-72	1/8" x 2" Cotter Pin
7 a.	993-300358	Pivot Pin Sleeve
b.	900-4912-72	1/4"-20NC x 3/4" Flat Head Cap Screw (Not Shown)
8.	900-4907-45	Tilt Indicator Gauge
9.	900-1902-42	Split Bushing - 1 1/4" OD x 1" ID x 1"
10.	900-4900-44	1"-8NC Jam Nut
11.	993-000352	Swing Pivot Pin
12.	993-300359	Pivot Pin Sleeve
13 a.	993-300357	Pivot Pin Sleeve
b.	900-4909-82	1/4"-20NC x 3/4" Socket Head Cap Screw (Not Shown)

NOTICE Nuts, bolts, washers, and all other components can be ordered by physical description.

NOTICE Parts may not be exactly as shown.

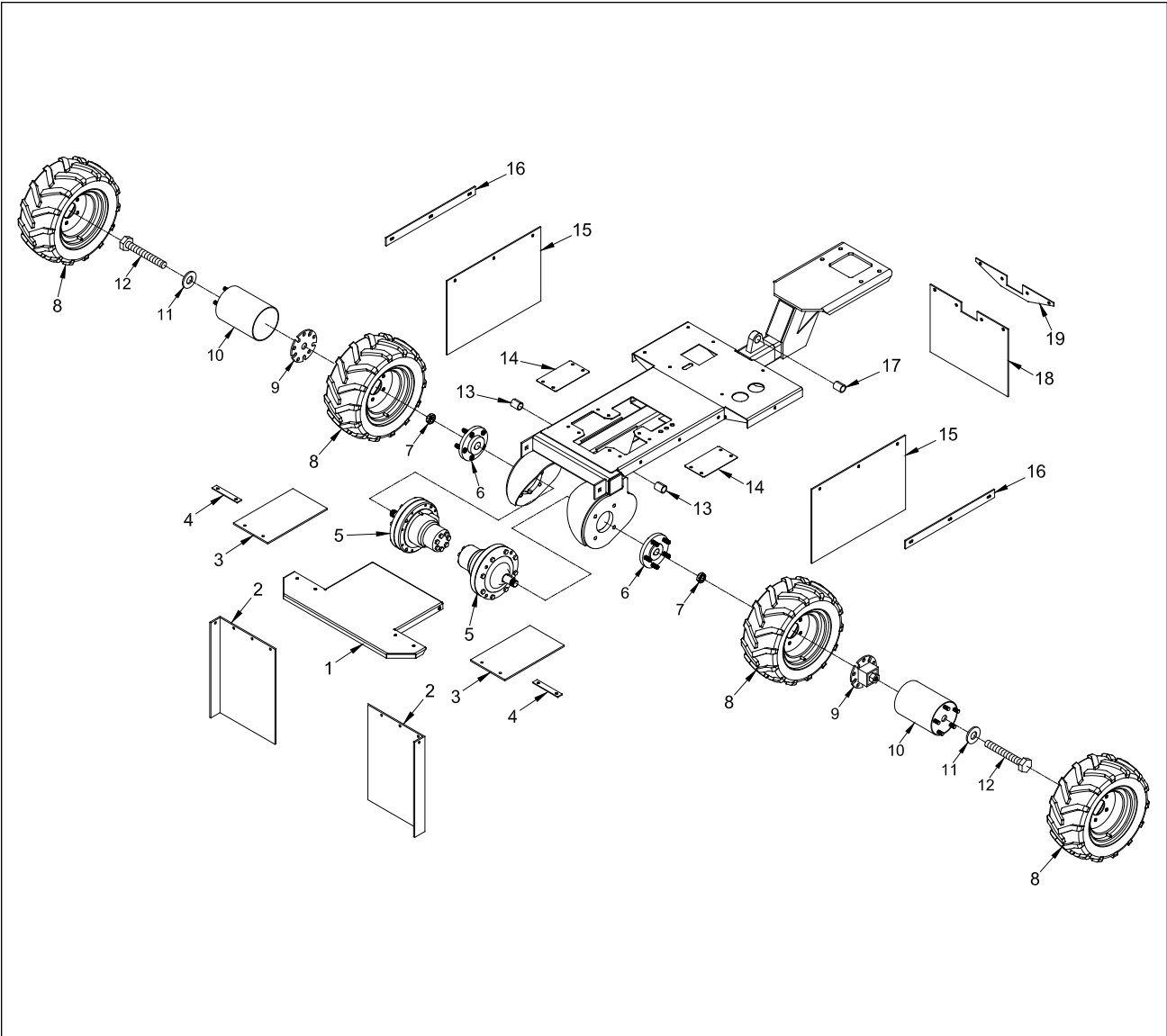

TELESCOPING TONGUE OPTION

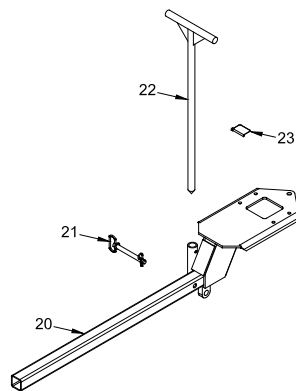

NOTICE Parts may not be exactly as shown.

Bandit

LOCATION	PART NUMBER	DESCRIPTION
1.	991-2000-24	Chip Pan Assembly
2.	991-3001-96	Chip Pan Rubber Curtain
3.	991-3000-98	Rubber Fender
4.	991-3001-08	Rubber Fender Strap
5.	900-3940-00	Hydraulic Motor With Brake
6 a.	993-100087	Wheel Hub Assembly
b.	900-5905-97	1/2"-20NF Stud Only
7.	900-3938-50	1"-20UNEF Hex Slotted Nut
8 a.	900-5909-22	18" x 8.50" - 10" Tire & White, 5 Bolt Rim (Specify Left Or Right)
b.	900-5909-20	18" x 8.50" - 10" Tire Only
c.	900-5909-21	10" x 6" White, 5 Bolt Rim Only
d.	900-5905-39	5.70 - 8" High Speed Traction Tire & White, 5 Bolt Rim (29" Wide Machine)
e.	900-5906-12	5.70 - 8" High Speed Traction Tire Only (29" Wide Machine)
f.	900-5906-03	8" x 3.75" White, 5 Bolt Rim Only (29" Wide Machine)
g.	900-4914-00	1/2"-20NF Lug Nut Only (Not Shown)
9 a.	993-2001-42	Dual Wheel Hub (35" Wide Machine)
b.	993-200096	Dual Wheel Hub (29" Wide Machine)
10 a.	993-2001-36	Dual Wheel Spacer (35" Wide Machine)
b.	993-200099	Dual Wheel Spacer (29" Wide Machine)
c.	993-1001-87	Dual Wheel Spacer Kit - Includes 9-12 (35" Wide Machine)
d.	993-100031	Dual Wheel Spacer Kit - Includes 9-12 (29" Wide Machine)
11 a.	900-4900-79	1" Flat Washer
b.	900-4908-99	1" Lock Washer (Not Shown)
12.	900-4913-38	1"-8NC x 5 1/2" Hex Head Bolt
13.	900-1902-50	Split Bushing - 1 1/4" OD x 1" ID x 1 1/2"
14.	993-3010-20	Pivot Cover
15.	993-3010-21	Side Rubber Curtain
16.	993-3010-39	Side Curtain Strap
17.	900-1902-42	Split Bushing - 1 1/4" OD x 1" ID x 1"
18.	993-3010-44	Rear Rubber Curtain
19.	993-3010-45	Rear Curtain Strap
20.	993-2001-71	Optional Telescoping Tongue Assembly
21.	900-4907-44	Lock Pin
22.	993-100027	Holding Stake Assembly
23.	900-4913-80	Snapper Pin - 5/16" x 2 3/4"

NOTICE Nuts, bolts, washers, and all other components can be ordered by physical description.

SINGLE STEERING WHEEL

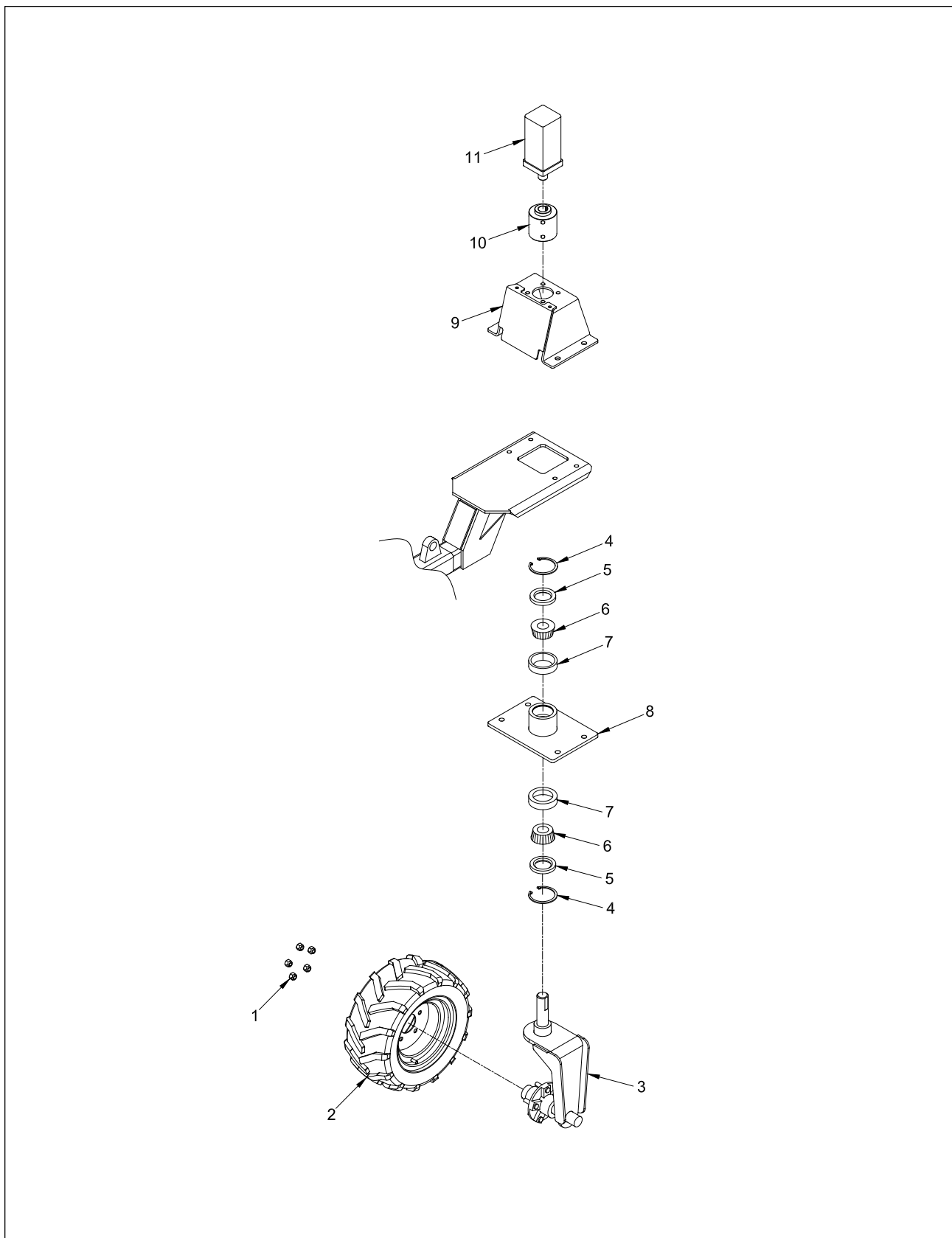

NOTICE Parts may not be exactly as shown.

Bandit

SINGLE STEERING WHEEL

LOCATION	PART NUMBER	DESCRIPTION
1.	900-4914-00	1/2"-20NF Lug Nut
2 a.	900-5909-22	18" x 8.50" - 10" Tire & White, 5 Bolt Rim (Specify Left Or Right)
b.	900-5909-20	18" x 8.50" - 10" Tire Only
c.	900-5909-21	10" x 6" White, 5 Bolt Rim Only
3 a.	991-2000-05	Single Steering Wheel Axle Assembly
b.	021-041-01	Grease Cap For Hub (Not Shown)
c.	085-001-00	Rubber Plug For Grease Cap (Not Shown)
d.	031-031-02	Inner & Outer Bearing For Hub (Not Shown)
e.	031-031-01	Inner & Outer Bearing Cup For Hub (Not Shown)
f.	010-060-00	Inner & Outer Seal For Hub (Not Shown)
g.	900-5905-97	1/2"-20NF Stud Only (Not Shown)
4.	900-1910-08	Retaining Ring
5.	900-1910-04	Bearing Seal
6.	900-1910-06	Pivot Bearing
7.	900-1910-05	Bearing Cup
8.	993-2001-54	Steering Bearing Housing Assembly
9 a.	993-2001-52	Motor Mount Assembly
b.	993-3009-71	Cover Plate Only
10 a.	993-3011-10	Hydraulic Motor Coupler
b.	900-4914-67	1/2"-13NC x 1" Cup Point Socket Set Screw (Not Shown)
11.	900-3921-57	Hydraulic Motor

NOTICE Nuts, bolts, washers, and all other components can be ordered by physical description.

DUAL STEERING WHEELS

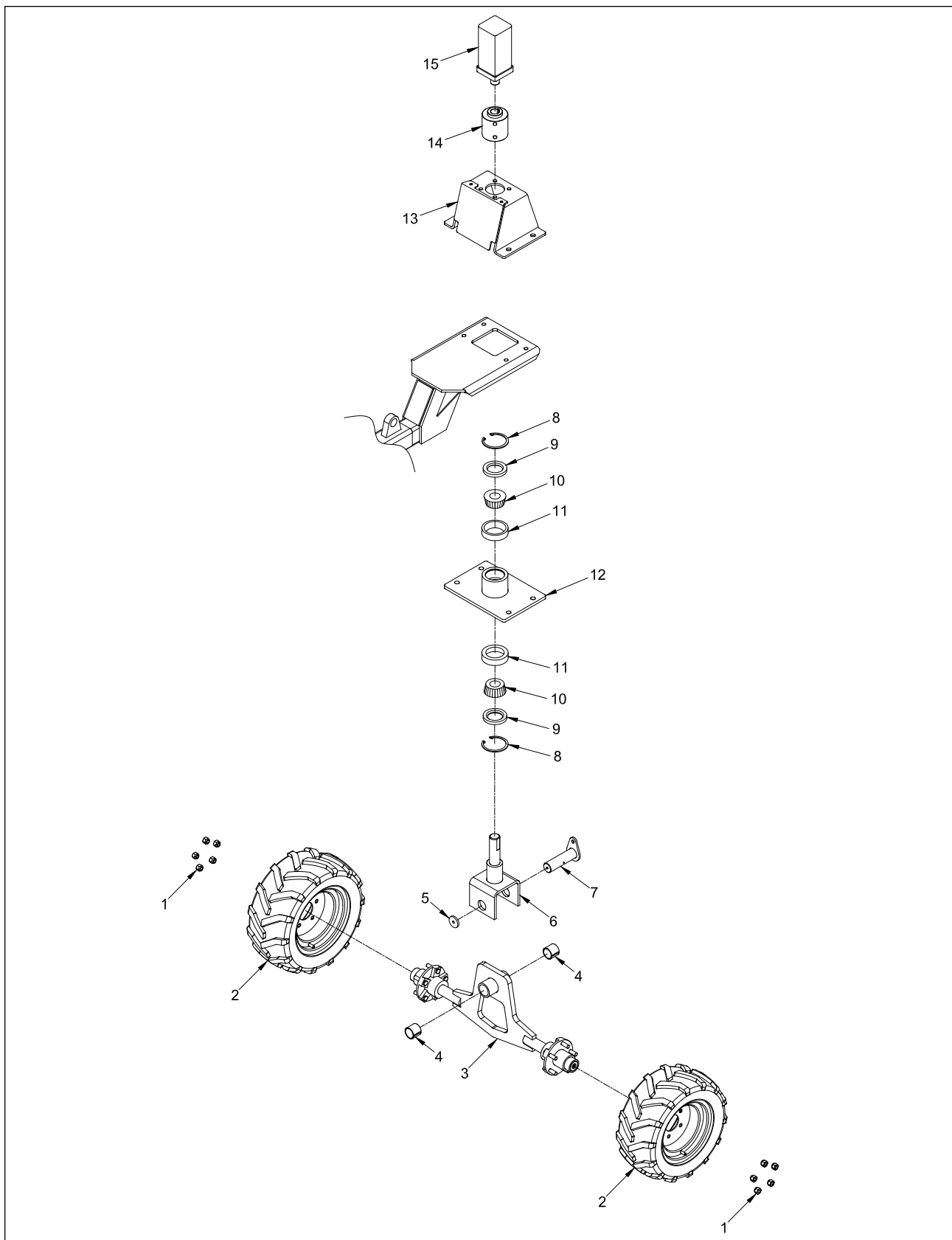

NOTICE Parts may not be exactly as shown.

Bandit

DUAL STEERING WHEELS

LOCATION	PART NUMBER	DESCRIPTION
1.	900-4914-00	1/2"-20NF Lug Nut
2 a.	900-5909-22	18" x 8.50" - 10" Tire & White, 5 Bolt Rim (Specify Left Or Right)
b.	900-5909-20	18" x 8.50" - 10" Tire Only
c.	900-5909-21	10" x 6" White, 5 Bolt Rim Only
d.	900-5905-39	5.70 - 8" High Speed Traction Tire & White, 5 Bolt Rim (29" Wide Machine)
e.	900-5906-12	5.70 - 8" High Speed Traction Tire Only (29" Wide Machine)
f.	900-5906-03	8" x 3.75" White, 5 Bolt Rim Only (29" Wide Machine)
3 a.	993-2001-69	Dual Wheel Steering Axle Assembly
b.	993-2001-68	Dual Wheel Steering Axle Assembly (29" Wide Machine)
c.	021-041-01	Grease Cap For Hub (Not Shown)
d.	085-001-00	Rubber Plug For Grease Cap (Not Shown)
e.	031-031-02	Inner & Outer Bearing For Hub (Not Shown)
f.	031-031-01	Inner & Outer Bearing Cup For Hub (Not Shown)
g.	010-060-00	Inner & Outer Seal For Hub (Not Shown)
h.	900-5905-97	1/2"-20NF Stud Only (Not Shown)
4.	900-1908-37	Split Bushing - 1 3/4" OD x 1 1/2" ID x 1 1/2"
5 a.	900-4913-27	1 3/4" OD x 3/8" ID x 1/8" Washer
b.	900-4900-13	3/8"-16NC x 1" Hex Head Bolt (Not Shown)
c.	900-4906-62	3/8" Lockwasher (Not Shown)
6.	993-2001-67	Shaft & Pivot Assembly
7 a.	993-200002	Steering Axle Pivot Pin
b.	900-4906-70	1/2"-13NC x 1" Hex Head Bolt (Not Shown)
c.	900-4906-86	1/2" Lockwasher (Not Shown)
8.	900-1910-08	Retaining Ring
9.	900-1910-04	Bearing Seal
10.	900-1910-06	Pivot Bearing
11.	900-1910-05	Bearing Cup
12.	993-2001-54	Steering Bearing Housing Assembly
13 a.	993-2001-52	Motor Mount Assembly
b.	993-3009-71	Cover Plate Only
14 a.	993-3011-10	Hydraulic Motor Coupler
b.	900-4914-67	1/2"-13NC x 1" Cup Point Socket Set Screw (Not Shown)
15.	900-3921-57	Hydraulic Motor

NOTICE Nuts, bolts, washers, and all other components can be ordered by physical description.

FOUR WHEEL DRIVE

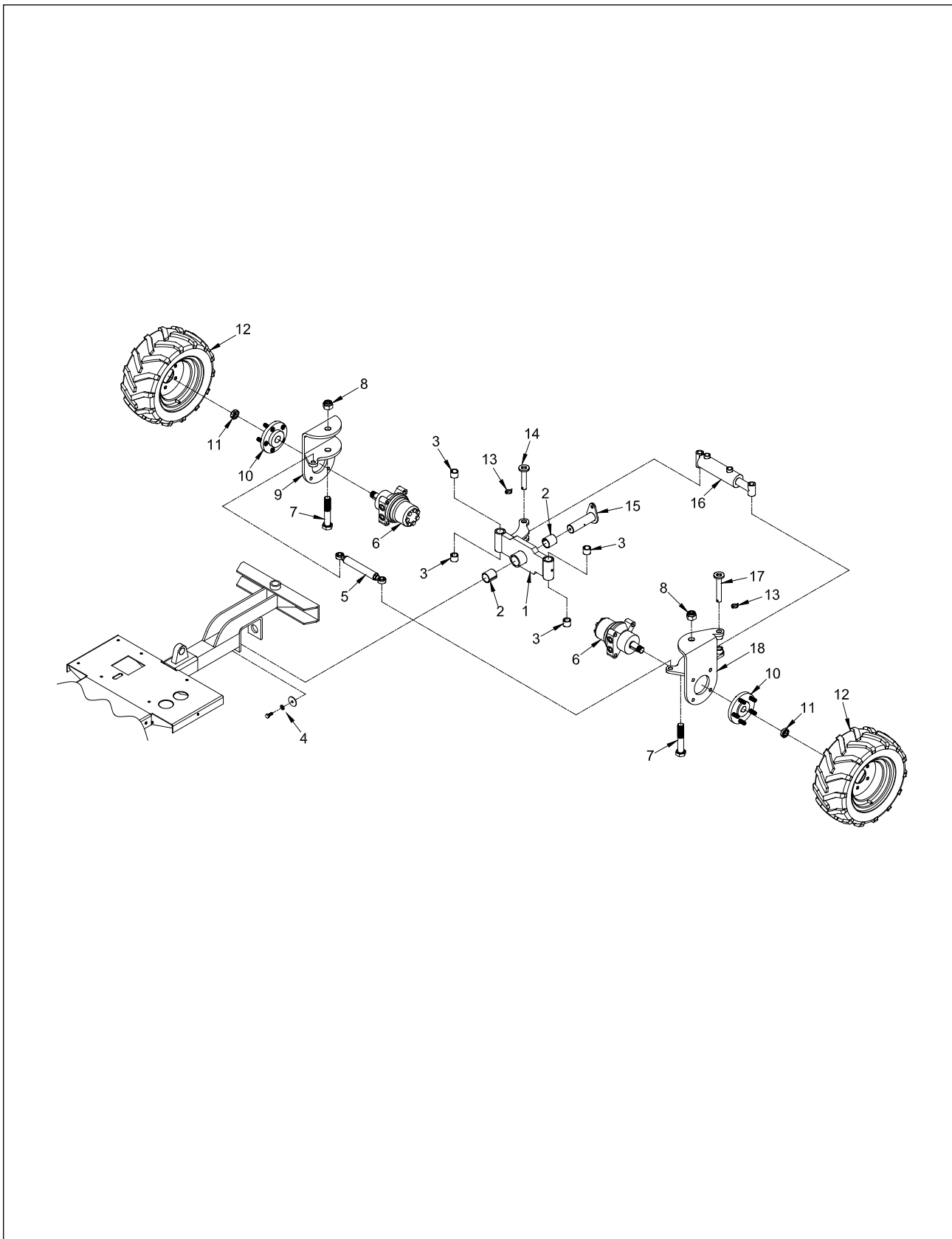

NOTICE Parts may not be exactly as shown.

Bandit

FOUR WHEEL DRIVE

LOCATION	PART NUMBER	DESCRIPTION
1.	993-2001-81	Steering Axle Assembly (Includes 2 & 3)
2.	900-1908-37	Split Bushing - 1 3/4" OD x 1 1/2" ID x 1 1/2"
3.	900-1902-42	Split Bushing - 1 1/4" OD x 1" ID x 1"
4 a.	900-4900-13	3/8"-16NC x 1" Hex Head Bolt
b.	900-4906-62	3/8" Lock Washer
c.	900-4913-27	1 3/4" OD x 3/8" ID x 1/8" Washer
5 a.	993-1001-91	Tie Rod Assembly
b.	900-4912-76	Tie Rod End
c.	900-4909-51	5/8"-18NF Hex Jam Nut
6.	900-3926-14	Hydraulic Motor Without Brake
7.	---	1"-8NC x 5 1/2" Hex Head Bolt (1 1/4" Of Thread) - Special
8.	900-4900-80	1"-8NC Nylon Insert Hex Lock Nut
9.	993-2001-38	Right Steering Motor Mount Assembly
10 a.	993-100087	Wheel Hub Assembly
b.	900-5905-97	1/2"-20NF Stud Only
11.	900-3938-50	1"-20UNEF Hex Slotted Nut
12 a.	900-5909-22	18" x 8.50" - 10" Tire & White, 5 Bolt Rim (Specify Left Or Right)
b.	900-5909-20	18" x 8.50" - 10" Tire Only
c.	900-5909-21	10" x 6" White, 5 Bolt Rim Only
13.	900-4907-28	Lynch Pin
14.	993-200023	Steering Cylinder Pin - 4" Long
15 a.	993-200002	Steering Axle Pivot Pin
b.	900-4906-70	1/2"-13NC x 1" Hex Head Bolt (Not Shown)
c.	900-4906-86	1/2" Lockwasher (Not Shown)
16.	900-3937-68	Steering Axle Cylinder
17.	993-200022	Steering Cylinder Pin - 5 1/8" Long
18.	993-2001-37	Left Steering Motor Mount Assembly

NOTICE Nuts, bolts, washers, and all other components can be ordered by physical description.

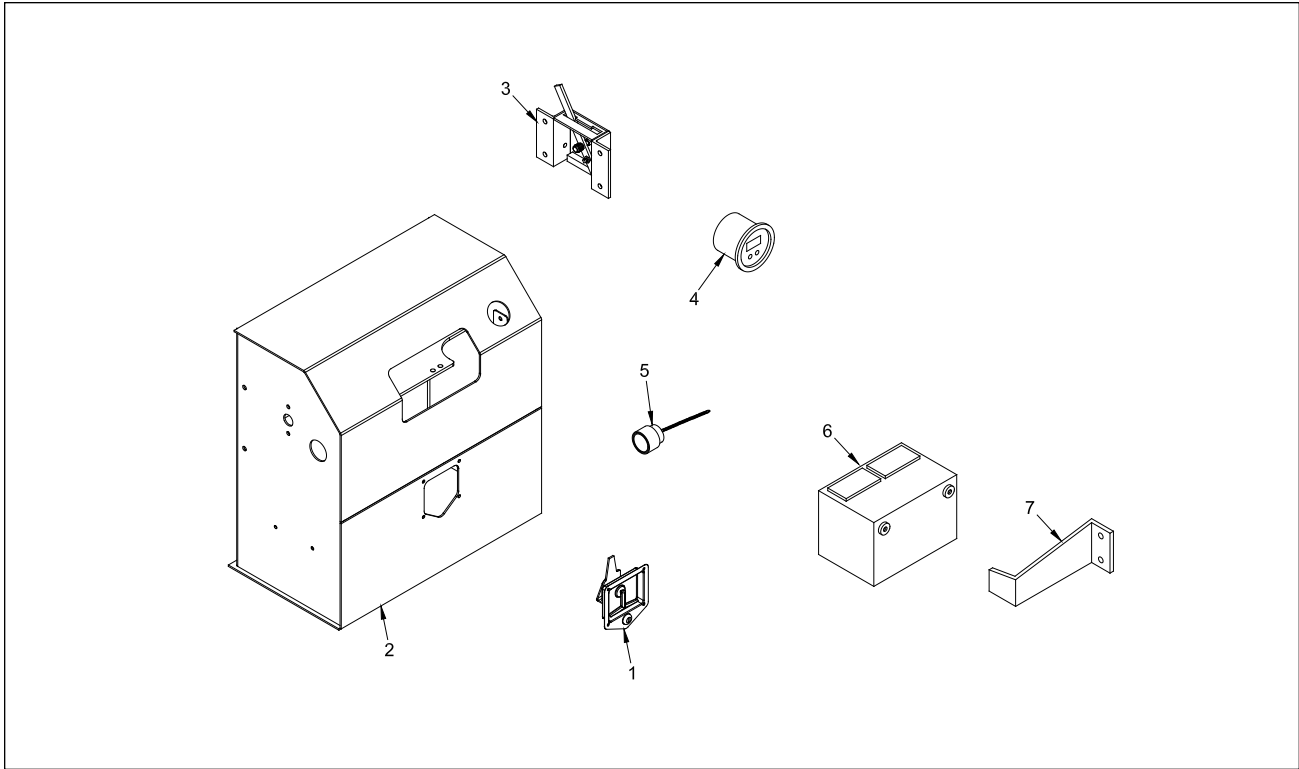

LOCATION	PART NUMBER	DESCRIPTION
1 a.	900-4908-19	"T" Handle Latch
1 b.	CH545	Key For "T" Handle Latch
2 a.	991-2000-29	Manual Control Box Assembly
2 b.	993-2001-80	Radio Control Box Assembly
3 a.	993-100116	Lombardini Throttle Lever Assembly (If Equipped)
3 b.	993-300462	Throttle Handle Only
3 c.	900-4908-88	Spring Only
3 d.	900-6907-63	Bowden Pin Only
3 e.	900-2902-02	Cable For Lombardini Throttle Lever Assembly (Not Shown)
4 a.	900-2903-76	Hour Meter
4 b.	900-2909-79	Tach / Hour Meter
4 c.	900-2906-82	Super Sweep Tach
5.	900-2908-63	Dust Cap And Chain For Tether Jack - Radio Remote Machine
6.	900-6910-57	525 CCA Battery - Side Mount
7.	993-300402	Battery Clamp

NOTICE Parts may not be exactly as shown.

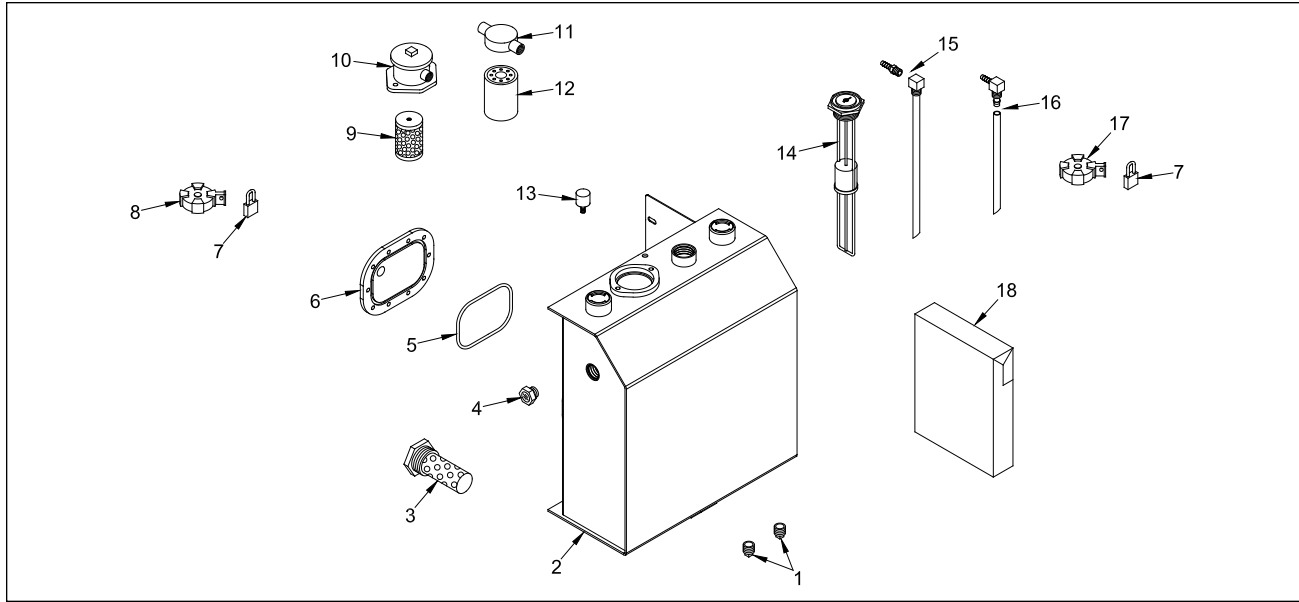

LOCATION	PART NUMBER	DESCRIPTION
1.	900-3922-60	Magnetic Drain Plug
2 a.	991-2000-30	Fuel & Hydraulic Tank Assembly With Internal Hydraulic Filter (Start 6/09)
b.	993-2001-63	Fuel & Hydraulic Tank Assembly With External Hydraulic Filter (Pre 6/09)
3 a.	900-3944-78	Suction Screen - SAE (Start 6/09)
b.	900-3900-07	Suction Screen - NPT (Pre 6/09)
4.	900-3900-44	Glass Sight Gauge For Hydraulic Tank
5.	900-7901-32	Rubber O-ring
6.	993-3010-96	Clean Out Door - Hydraulic Tank
7 a.	900-4912-40	Padlock With Short Shackle For Tank With Locking Cap
b.	P812	Key For Padlock (Not Shown)
8 a.	900-3941-30	Hydraulic Locking Fill Cap - Black
b.	900-3935-06	Keeper For Fuel & Hydraulic Locking Fill Cap (Not Shown)
9.	900-3938-96	In-Tank Hydraulic Oil Filter Only (Start 6/09)
10.	900-3938-23	In-Tank Return Filter Ass'y - Includes Filter (Start 6/09)
11.	900-3900-09	External Filter Head (Pre 6/09)
12.	900-3938-08	External Hydraulic Oil Filter (Pre 6/09)
13.	900-9905-35	Rubber Bumper Stop
14 a.	900-2910-39	Optional Rochester Sight Gauge For Fuel Tank - 20"
b.	900-2903-55	Face For Sight Gauge Only
15 a.	900-3909-00	Drop Pipe Assembly For Diesel Suction Line
b.	900-3926-82	Hose Barb
16 a.	900-3936-69	Return / Suction 1/4" NPTF Elbow 3/16" Hose Barb x 1/4" Hose Barb
b.	900-3909-03	1/4" ID Drop Pipe
17 a.	900-3941-30	Fuel (Gasoline) Locking Fill Cap - Black
b.	900-3941-31	Fuel (Diesel) Locking Fill Cap - Green
c.	900-3935-06	Keeper For Fuel & Hydraulic Locking Fill Cap (Not Shown)
18.	900-9902-07	Manual Holder

NOTICE Components vary with fuel type.
Specify gas or diesel when ordering fuel tank components.

NOTICE Tank assemblies vary with options.
Specify all options when ordering.

NOTICE Parts may not be exactly as shown.

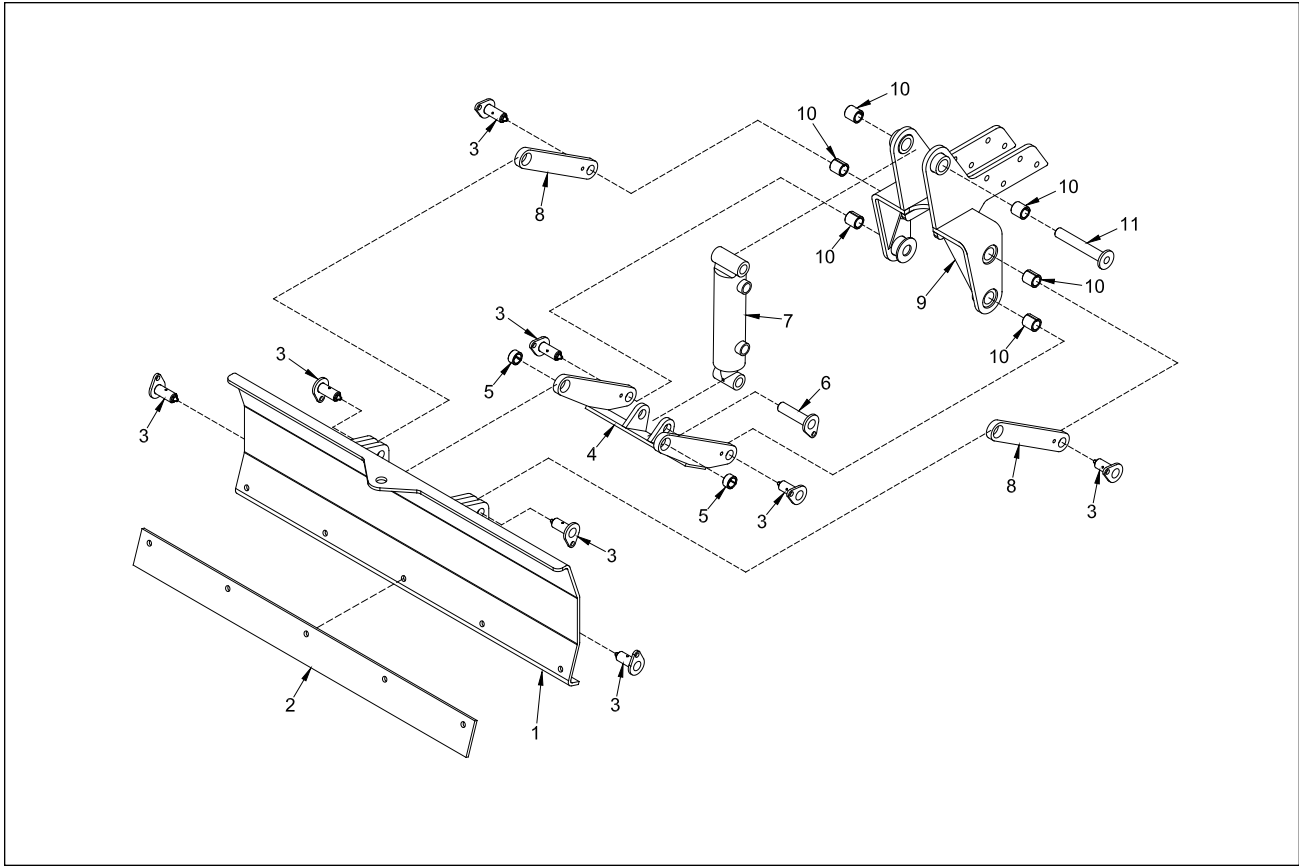

LOCATION	PART NUMBER	DESCRIPTION
1.	991-2000-36	Grading Blade Assembly (Includes #2)
2.	991-3001-40	Grading Blade Wear Bar
3.	991-2000-38	Grading Blade Arm Pin
4.	991-2000-35	Grading Blade Lower Arm Assembly (Includes #5)
5.	900-1916-28	Split Bushing - 1" OD x 3/4" ID x 1/2"
6.	991-2000-37	Lower Cylinder Pin
7.	--	Cylinder For Grading Blade
8.	991-3001-33	Grading Blade Arm
9.	991-2000-34	Grading Blade Mount (Includes #10)
10.	900-1908-38	Split Bushing - 1" OD x 3/4" ID x 1"
11.	991-2000-39	Upper Cylinder Pin

NOTICE Nuts, bolts, washers, and all other components can be ordered by physical description.

NOTICE Parts may not be exactly as shown.



LOCATION	PART NUMBER	DESCRIPTION
1.	900-2920-40	Transmitter - Omnex
2.	900-2916-75	Receiver - Omnex
3 a.	900-2918-47	Tether
b.	900-2908-63	Cap For Tether Jack On Machine (Not Shown)
4.	900-2920-41	Radio Remote Kit - Omnex (includes 1 & 2)

NOTICE Parts may not be exactly as shown.

MODEL 2150XP HYDRAULIC COMPONENTS (START 6/09)

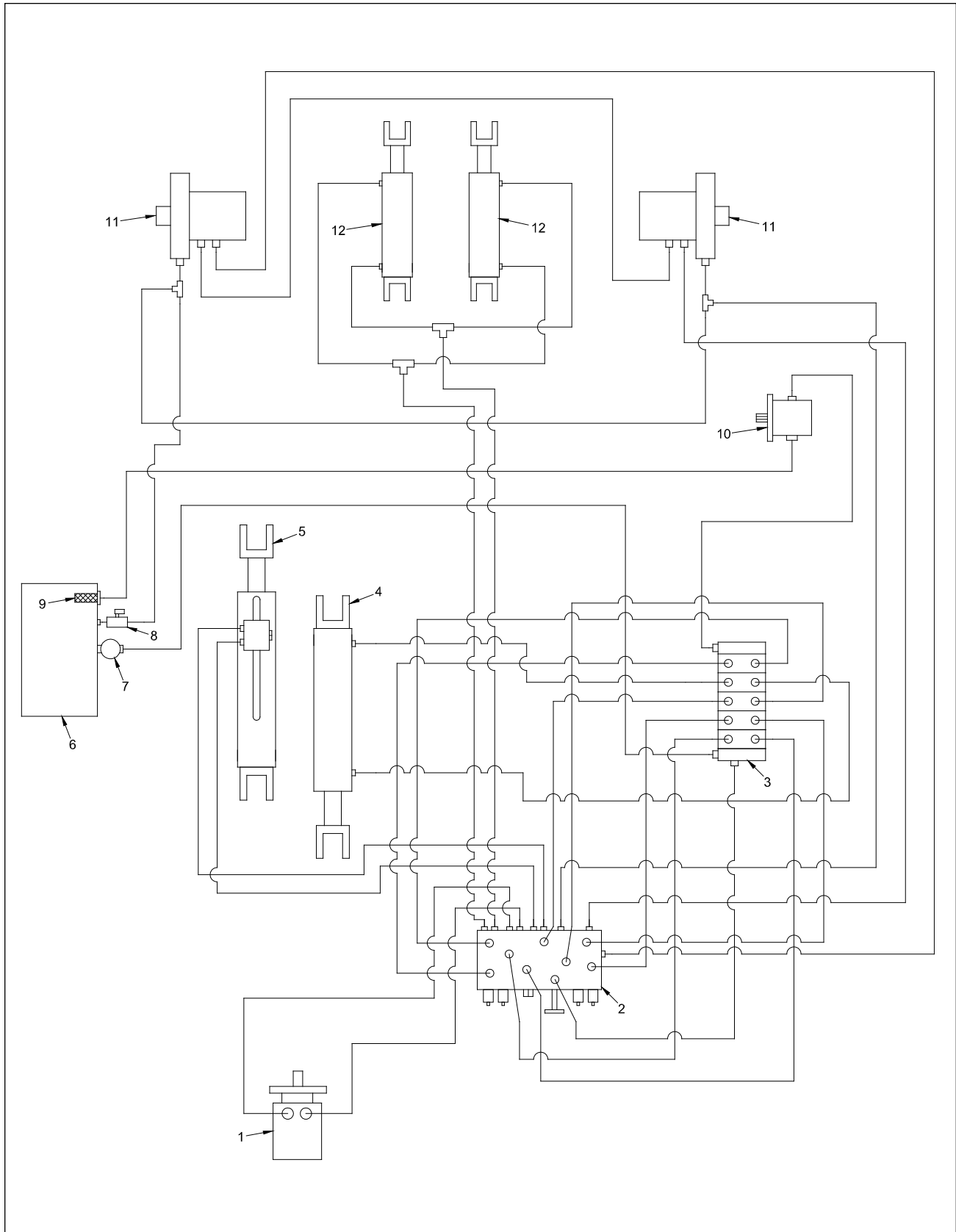

NOTICE Parts may not be exactly as shown.

Bandit

MODEL 2150XP HYDRAULIC COMPONENTS (START 6/09)

LOCATION	PART NUMBER	DESCRIPTION
1.	900-3921-57	Steering Motor
2 a.	900-3945-13	Brake / Divider Manifold Assembly
b.	900-3929-09	Counter Balance Relief Only
c.	900-3928-25	Brake Release Hand Pump Only
d.	900-3945-71	Brake Release Needle Valve Only
e.	900-3945-72	Drive & Swing Flow Control Needle Valve Only
f.	900-3945-73	Check Valve Only
g.	900-3945-74	Shuttle Valve Only
h.	900-3945-75	Pressure Override Check Valve Only
i.	900-3945-76	.030" Orifice Only
j.	900-3945-77	Cavity Plug (2 wheel drive only)
3 a.	900-3926-07	Manual Control Valve - 4 Bank
b.	900-3926-06	Manual Control Valve - 5 Bank
4.	900-3937-10	Optional Telescopic Tongue Cylinder
5 a.	900-3937-13	Cutter Head Lift Cylinder
b.	900-3944-87	Counter Balance Relief Only
6.	See Page 85	Hydraulic Tank
7 a.	900-3938-96	In-Tank Hydraulic Oil Filter (Start 6/09)
b.	900-3938-23	In-Tank Return Filter Ass'y - Includes Filter (Start 6/09)
8.	900-3943-65	1/4" Ball Valve
9.	900-3944-78	Suction Screen - SAE (Start 6/09)
10.	**	Hydraulic Pump
11.	900-3940-00	Drive Motor With Internal Brake
12.	900-3937-09	Cutter Head Swing Cylinder

**** Components will vary with engines, order by Serial Number of machine.**

NOTICE Make sure to order components according to fitting type, fittings may vary on all components. Hydraulic components, fittings, hoses will vary depending on optional equipment. Order by physical description.

MODEL 2150XP HYDRAULIC COMPONENTS (PRE 6/09)

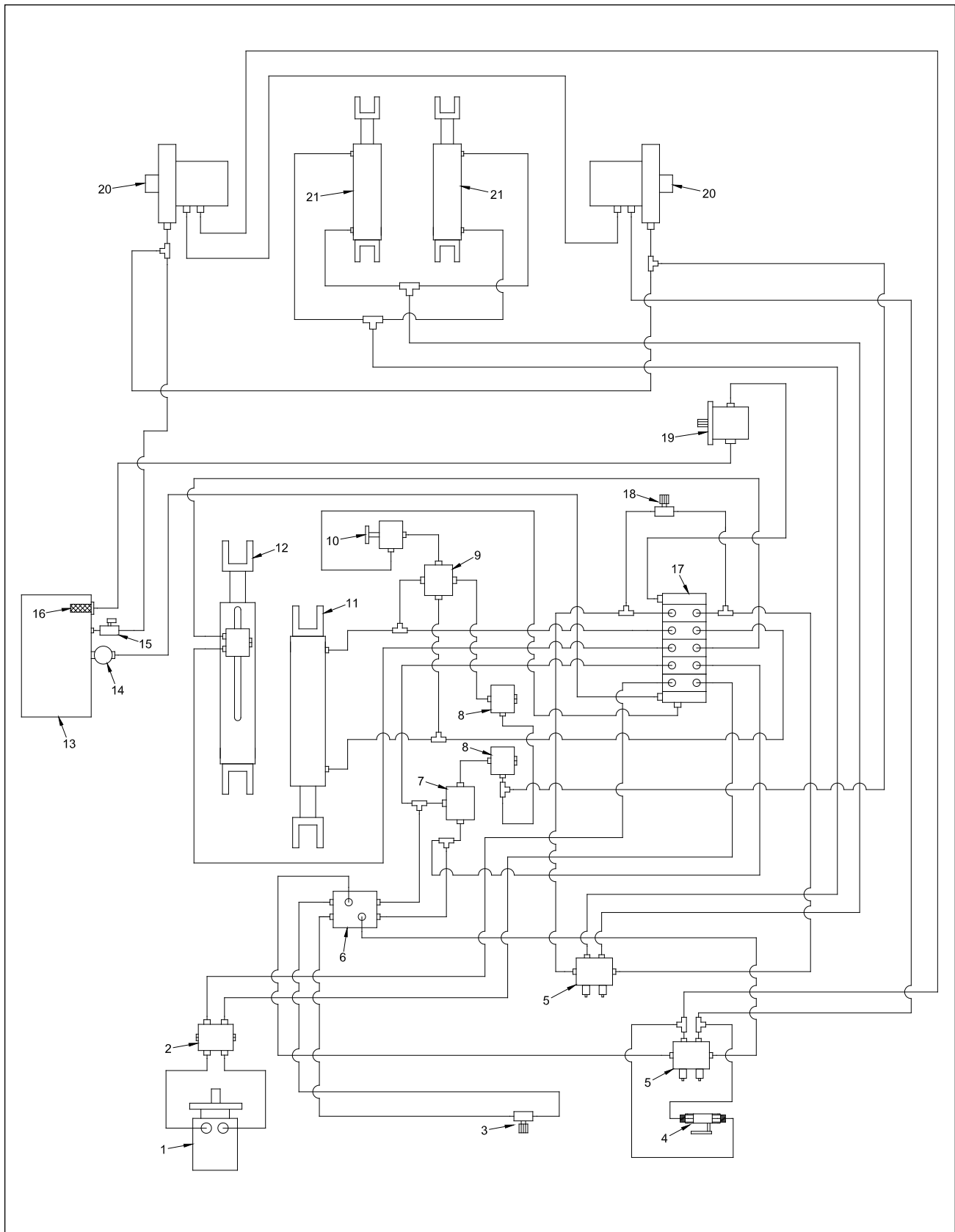

NOTICE Parts may not be exactly as shown.

Bandit

MODEL 2150XP HYDRAULIC COMPONENTS (PRE 6/09)

LOCATION	PART NUMBER	DESCRIPTION
1.	900-3921-57	Steering Motor
2.	900-3923-05	Steering Counter Balance
3.	900-3943-60	Swing Speed Control
4.	900-3926-11	1/2" Ball Valve
5 a.	900-3918-65	Double Counter Balance
b.	900-3929-09	Counter Balance Relief Only
6.	900-3917-50	Double "T" Block
7 a.	900-3943-53	Brake Shuttle Valve Body
b.	900-3943-52	Brake Shuttle Valve Cartridge
8 a.	900-3943-55	Brake Check Valve Body
b.	900-3943-54	Brake Check Valve Cartridge
9.	900-3937-58	4 Way Junction Block
10.	900-3928-25	Brake Hand Pump
11.	900-3937-10	Optional Telescopic Tongue Cylinder
12 a.	900-3937-13	Cutter Head Lift Cylinder
b.	900-3944-87	Counter Balance Relief Only
13.	See Page 85	Hydraulic Tank
14 a.	900-3938-08	External Hydraulic Oil Filter (Pre 6/09)
b.	900-3900-09	External Filter Head (Pre 6/09)
15.	900-3943-65	1/4" Ball Valve
16.	900-3900-07	Suction Screen - NPT (Pre 6/09)
17 a.	900-3926-07	Manual Control Valve - 4 Bank
b.	900-3926-06	Manual Control Valve - 5 Bank
18.	900-3943-60	Travel Speed Control
19.	**	Hydraulic Pump
20.	900-3940-00	Drive Motor With Internal Brake
21.	900-3937-09	Cutter Head Swing Cylinder

**** Components will vary with engines, order by Serial Number of machine.**

NOTICE Make sure to order components according to fitting type, fittings may vary on all components. Hydraulic components, fittings, hoses will vary depending on optional equipment. Order by physical description.

MODEL 2150XP WITH REMOTE CONTROLS
HYDRAULIC COMPONENTS

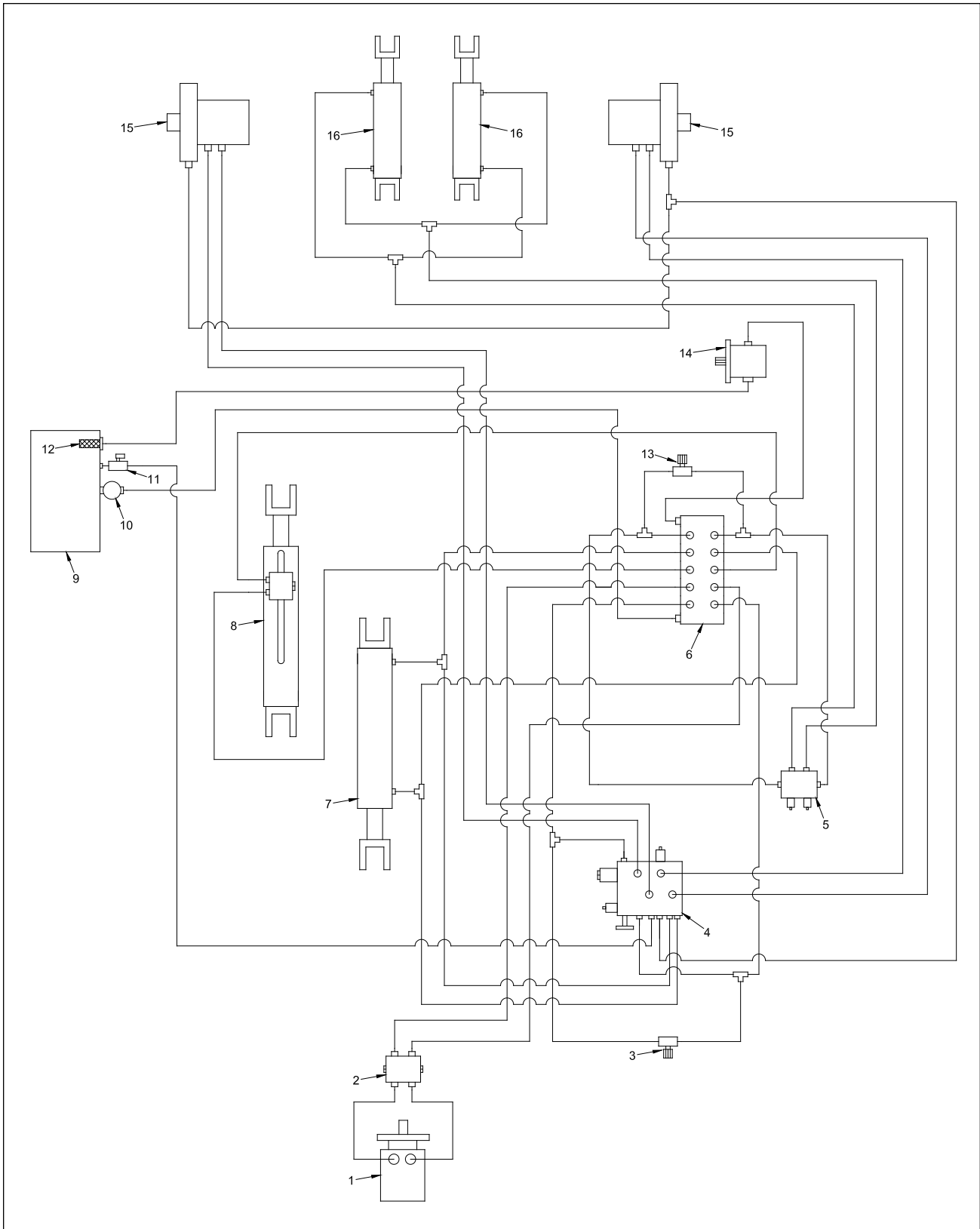

NOTICE Parts may not be exactly as shown.

Bandit

**MODEL 2150XP WITH REMOTE CONTROLS
HYDRAULIC COMPONENTS**

LOCATION	PART NUMBER	DESCRIPTION
1.	900-3937-68	Steering Cylinder
2.	900-3923-05	Steering Counter Balance
3.	900-3924-30	Swing Speed Control
4 a.	900-3940-96	Divider / Brake Manifold Assembly
b.	900-3929-09	Counter Balance Relief Only
c.	900-3928-08	Divider Cartridge Only
d.	900-3929-22	Bypass Valve Cartridge Only
e.	900-3929-23	Bypass Coil
f.	900-3929-24	Brake Check Valve Cartridge
g.	900-3929-25	Brake Shuttle Valve Cartridge
h.	900-3929-03	Series/Parallel Valve Cartridge Only
i.	900-3944-97	Series/Parallel Coil
j.	900-3944-98	Flow Control Needle Valve
k.	900-3938-62	.030" Orifice
5 a.	900-3918-65	Double Counter Balance
b.	900-3929-09	Counter Balance Relief Only
6.	See Page ??	Electric Control Manifold
7.	900-3937-10	Optional Telescopic Tongue Cylinder
8 a.	900-3937-13	Cutter Head Lift Cylinder
b.	900-3944-87	Counter Balance Relief Only
9.	See Page 85	Hydraulic Tank
10 a.	900-3938-96	In-Tank Hydraulic Oil Filter (Start 6/09)
b.	900-3938-23	In-Tank Return Filter Ass'y - Includes Filter (Start 6/09)
c.	900-3938-08	External Hydraulic Oil Filter (Pre 6/09)
d.	900-3900-09	External Filter Head (Pre 6/09)
11.	900-3943-65	1/4" Ball Valve
12 a.	900-3944-78	Suction Screen - SAE (Start 6/09)
b.	900-3900-07	Suction Screen - NPT (Pre 6/09)
13.	900-3924-30	Travel Speed Control
14.	**	Hydraulic Pump
15.	900-3940-00	Drive Motor With Internal Brake
16.	900-3937-09	Cutter Head Swing Cylinder

**** Components will vary order by Serial Number of machine.**

NOTICE Make sure to order components according to fitting type, fittings may vary on all components. Hydraulic components, fittings, hoses will vary depending on optional equipment. Order by physical description.

MODEL 2150XP / 2450XP WITH FOUR WHEEL DRIVE
HYDRAULIC COMPONENTS

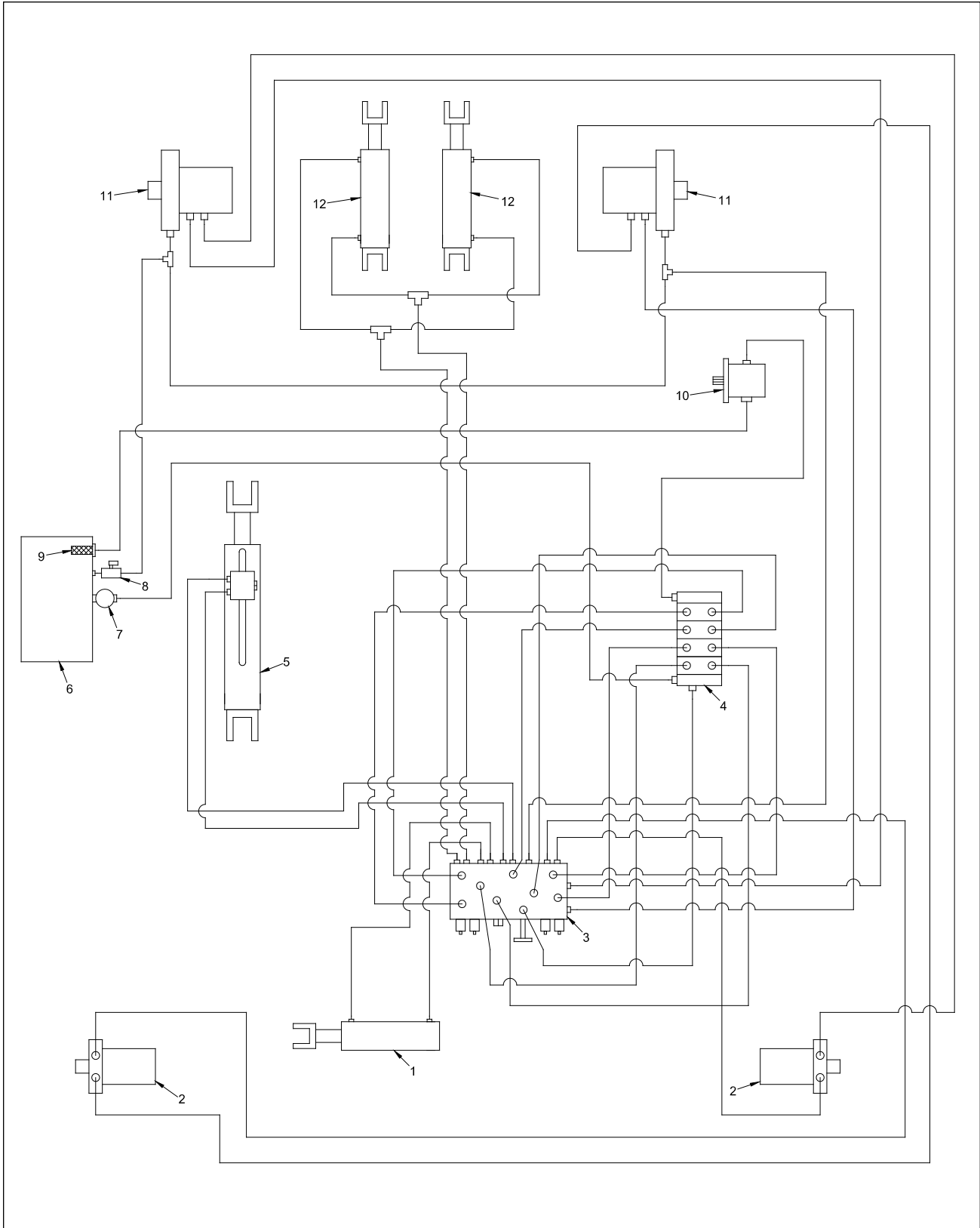

NOTICE Parts may not be exactly as shown.

Bandit

**MODEL 2150XP / 2450XP WITH FOUR WHEEL DRIVE
HYDRAULIC COMPONENTS**

LOCATION	PART NUMBER	DESCRIPTION
1.	900-3937-68	Steering Cylinder
2.	900-3926-14	Rear Drive Wheel Motor Without Brake
3 a.	900-3945-13	Brake / Divider Manifold Assembly
b.	900-3929-09	Counter Balance Relief Only
c.	900-3928-25	Brake Release Hand Pump Only
d.	900-3945-71	Brake Release Needle Valve Only
e.	900-3945-72	Drive & Swing Flow Control Needle Valve Only
f.	900-3945-73	Check Valve Only
g.	900-3945-74	Shuttle Valve Only
h.	900-3945-75	Pressure Override Check Valve Only
i.	900-3945-76	.030" Orifice Only
j.	900-3945-77	Cavity Plug (2 wheel drive only)
4 a.	900-3926-07	Manual Control Valve - 4 Bank
b.	900-3926-06	Manual Control Valve - 5 Bank
5 a.	900-3937-13	Cutter Head Lift Cylinder
b.	900-3944-87	Counter Balance Relief Only
6.	See Page 85	Hydraulic Tank
7 a.	900-3938-96	In-Tank Hydraulic Oil Filter (Start 6/09)
b.	900-3938-23	In-Tank Return Filter Ass'y - Includes Filter (Start 6/09)
c.	900-3938-08	External Hydraulic Oil Filter (Pre 6/09)
d.	900-3900-09	External Filter Head (Pre 6/09)
8.	900-3943-65	1/4" Ball Valve
9 a.	900-3944-78	Suction Screen - SAE (Start 6/09)
b.	900-3900-07	Suction Screen - NPT (Pre 6/09)
10.	**	Hydraulic Pump
11.	900-3940-00	Drive Motor With Internal Brake
12.	900-3937-09	Cutter Head Swing Cylinder
13.	--	Grading Blade Cylinder (Not Shown)

**** Components will vary order by Serial Number of machine.**

NOTICE Make sure to order components according to fitting type, fittings may vary on all components. Hydraulic components, fittings, hoses will vary depending on optional equipment. Order by physical description.

MODEL 2150XP / 2450XP WITH FOUR WHEEL DRIVE & REMOTE CONTROLS - HYDRAULIC COMPONENTS

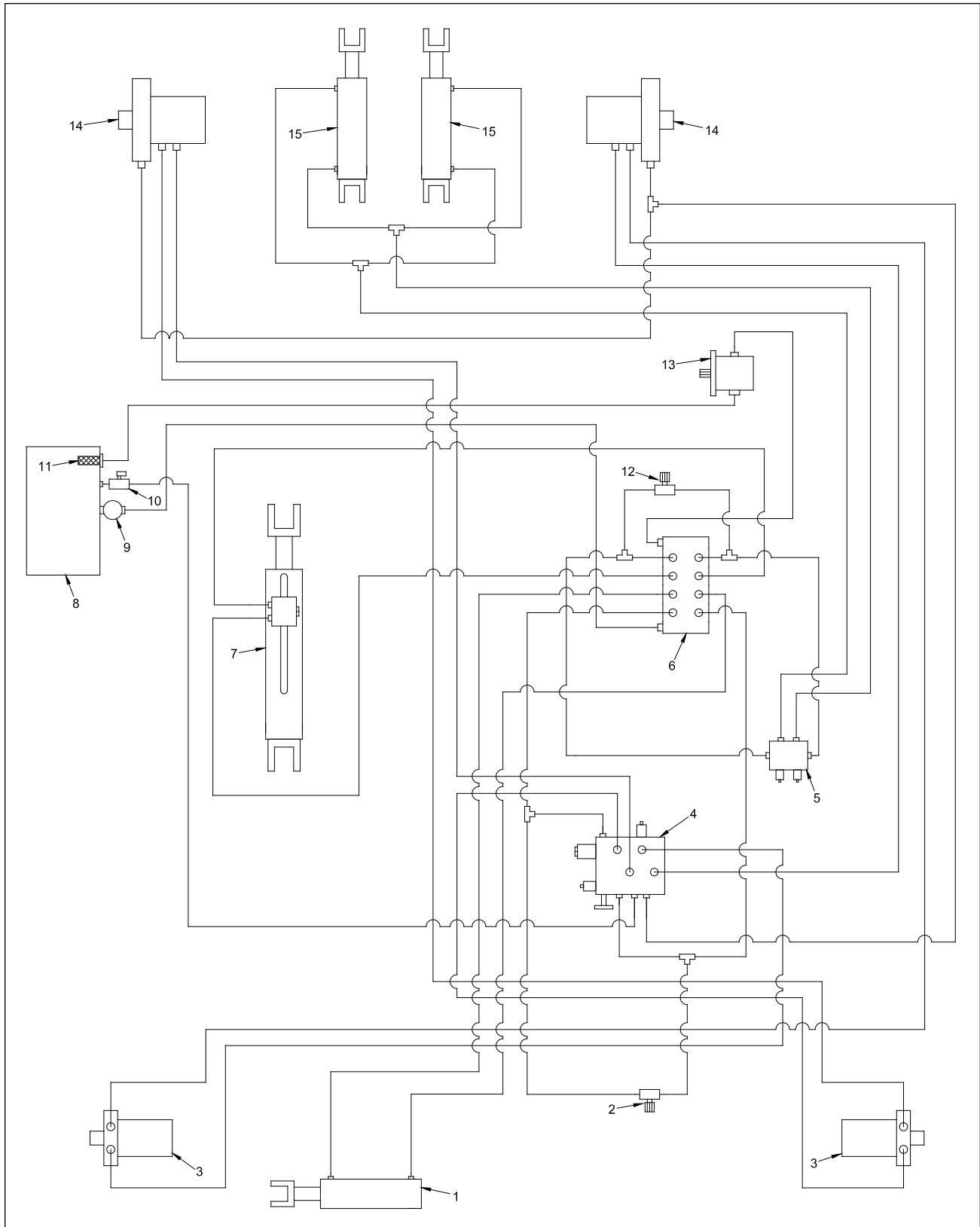

NOTICE Parts may not be exactly as shown.







Bandit

MODEL 2150XP / 2450XP WITH FOUR WHEEL DRIVE & REMOTE CONTROLS - HYDRAULIC COMPONENTS

LOCATION	PART NUMBER	DESCRIPTION
1.	900-3937-68	Steering Cylinder
2.	900-3924-30	Swing Speed Control
3.	900-3926-14	Rear Drive Wheel Motor Without Brake
4 a.	900-3940-96	Divider / Brake Manifold Assembly
b.	900-3929-09	Counter Balance Relief Only
c.	900-3928-08	Divider Cartridge Only
d.	900-3929-22	Bypass Valve Cartridge Only
e.	900-3929-23	Bypass Coil
f.	900-3929-24	Brake Check Valve Cartridge
g.	900-3929-25	Brake Shuttle Valve Cartridge
h.	900-3929-03	Series/Parallel Valve Cartridge Only
i.	900-3944-97	Series/Parallel Coil
j.	900-3944-98	Flow Control Needle Valve
k.	900-3938-62	.030" Orifice
5 a.	900-3918-65	Double Counter Balance
b.	900-3929-09	Counter Balance Relief Only
6.	See Page ??	Electric Control Manifold
7 a.	900-3937-13	Cutter Head Lift Cylinder
b.	900-3944-87	Counter Balance Relief Only
8.	See Page 85	Hydraulic Tank
9 a.	900-3938-96	In-Tank Hydraulic Oil Filter (Start 6/09)
b.	900-3938-23	In-Tank Return Filter Ass'y - Includes Filter (Start 6/09)
c.	900-3938-08	External Hydraulic Oil Filter (Pre 6/09)
d.	900-3900-09	External Filter Head (Pre 6/09)
10.	900-3943-65	1/4" Ball Valve
11 a.	900-3944-78	Suction Screen - SAE (Start 6/09)
b.	900-3900-07	Suction Screen - NPT (Pre 6/09)
12.	900-3924-30	Travel Speed Control
13.	**	Hydraulic Pump
14.	900-3940-00	Drive Motor With Internal Brake
15.	900-3937-09	Cutter Head Swing Cylinder

**** Components will vary order by Serial Number of machine.**

NOTICE Make sure to order components according to fitting type, fittings may vary on all components. Hydraulic components, fittings, hoses will vary depending on optional equipment. Order by physical description.

<p>1.</p>  <p>In-Tank Return Filter Ass'y: 900-3938-23 (Start 6/09) In-Tank Filter Only (Start 6/09)</p>	<p>2.</p>  <p>Filter Head: 900-3900-09 (Pre 6/09)</p>
<p>4.</p>  <p>Suction Screen: 900-3944-78 (Start 6/09) 900-3900-07 (Pre 6/09)</p>	<p>3.</p>  <p>Hydraulic Oil Filter: 900-3938-08 (Pre 6/09)</p>
<p>6.</p>  <p>Drive Wheel Motor With Brake: 900-3940-00 Castle Nut Only: 900-3938-50</p>	<p>5.</p>  <p>Model 2150 Steering Motor: 900-3921-57</p> <p>7.</p>  <p>Model 2150 With 4WD & Model 2450 Drive Wheel Motor Without Brake: 900-3926-14 Castle Nut Only: 900-3938-50</p>

NOTICE Parts may not be exactly as shown.

Bandit

<p>1.</p>  <p>Hydraulic Pump: 900-3943-85 With Kohler Engine (Start 8/09)</p>	<p>2.</p>  <p>Hydraulic Pump: 900-3938-89 With Kohler Engine (Pre 8/09) or Briggs & Stratton Engine</p>
<p>3.</p>  <p>Pump Coupler Ass'y: 900-1915-59 With Kohler Engine (Pre 8/09) or Briggs & Stratton Engine</p> <p>Pump Coupler Body Only: 900-1915-84 29" Wide Machine (Pre 8/09)</p> <p>Pump Coupler Spider Only: 900-1915-85 29" Wide Machine (Pre 8/09)</p>	
<p>4.</p>  <p>Hydraulic Pump: 900-3942-84 With Caterpillar Tier 3 Engine</p>	<p>5.</p>  <p>Hydraulic Pump: --- With Kubota Engine</p>

NOTICE Parts may not be exactly as shown.

1.



1/2" Ball Valve: 900-3926-11

2.



1/4" Ball Valve: 900-3943-65

3.



Needle Valve: 900-3943-60
(Swing & Travel Speed Adjustment)

4.

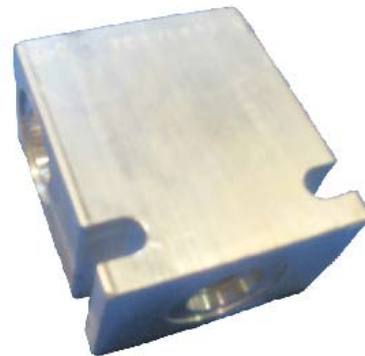

4 Way Junction Block: 900-3937-58

5.



Double "T" Block: 900-3917-50

6.



Brake Hand Pump: 900-3928-25

NOTICE Parts may not be exactly as shown.

Bandit

1.



Model 2150 (START 6/09)

Divider / Brake Manifold Assembly	900-3945-13
Counter Balance Relief Only	900-3929-09
Brake Hand Pump Only	900-3928-25
Brake Release Needle Valve Only	900-3945-71
Flow Control Needle Valve Only	900-3945-72
Check Valve	900-3945-73
Shuttle Valve	900-3945-74
Pressure Override Check Valve	900-3945-75
.030" Orifice	900-3945-76
Cavity Plug (2 wheel drive only)	900-3945-77

2.



Model 2150 With 4WD & Model 2450

Divider / Brake Manifold Assembly	900-3940-96
Counter Balance Relief Only	900-3929-09
Divider Cartridge Only	900-3928-08
Bypass Valve Cartridge Only	900-3929-22
Bypass Coil	900-3929-23
Brake Check Valve Cartridge	900-3929-24
Brake Shuttle Valve Cartridge	900-3929-25
Series/Parallel Valve Cartridge Only	900-3923-03
Series/Parallel Coil	900-3944-97
Flow Control Needle Valve	900-3944-98
.030" Orifice	900-3938-62

3.



Brake Shuttle Valve Body: 900-3943-53
Brake Shuttle Valve Cartridge: 900-3943-52

4.



Brake Check Valve Body: 900-3943-55
Brake Check Valve Cartridge: 900-3943-54

NOTICE Parts may not be exactly as shown.

1.



Steering Counter Balance: 900-3923-05

2.



Double Counter Balance: 900-3918-65
Counter Balance Relief Only: 900-3929-09

3.



Upper Frame Lift Cylinder: 900-3937-13
Counter Balance Relief: 900-3944-87

4.



Swing Cylinder: 900-3937-09

5.



Model 2150 With 4WD & Model 2450
Steering Cylinder: 900-3937-68

6.



Optional Telescoping Tongue Cylinder: 900-3937-10

7.



Model 2150 With 4WD & Model 2450
Grading Blade Cylinder: ---

NOTICE Parts may not be exactly as shown.

1.



Manual Control Valve - 4 Bank: 900-3926-07
 Manual Control Valve - 5 Bank: 900-3926-06

2.



Electric Control Manifold With Valves: 900-3936-79
 D03 Control Valve Assembly: 900-3929-14
 D03 Coil Only: 900-3931-01
 Counter Balance Only: 900-3929-09
 High Relief Valve Only: 900-3929-12
 Low Relief Valve Only: 900-3929-11
 Needle Valve Only: 900-3936-80

3.



Dual Coil Super Sweep Valve: 900-3930-99
 Coil Only: 900-3931-01
 Nut For Coil: 900-3931-02
 O-Ring For Coil: 900-3931-03

4.



Subplate For Super Sweep Valve: 900-3926-12

NOTICE Parts may not be exactly as shown.

