



BRUSH BANDIT

**BUILT WITH QUALITY
AND DESIGN FIRST**

ATTENTION:

Depending on what replacement parts you are ordering, we will need the following information:

GRINDER COMPONENTS

Serial Number
Model Number of Grinder

ENGINE COMPONENTS

Brand
Engine Serial Number
Engine Spec. Number

CLUTCH COMPONENTS

Brand
Serial Number
Assembly of Clutch

STUMP GRINDER MODELS 4000T/5000T OPERATING & PARTS MANUAL

Model No: _____

Serial No: _____

DEALER:

Name: _____

Address: _____

City/State: _____

Phone No: _____

Delivery Date: _____

Engine Make: _____

Serial No: _____

Clutch Make: _____

Model: _____ S/N _____



Copyright 9/10

MANUFACTURED BY
BANDIT INDUSTRIES, INC.

6750 Millbrook Road

REMUS, MICHIGAN, USA 49340

PHONE: (800) 952-0178 IN USA

PHONE: (989) 561-2270 OR 561-2272

FAX: (989) 561-2273 ~ SALES DEPT.

FAX: (989) 561-2962 ~ PARTS/SERVICE

E-MAIL: www.banditchippers.com

TABLE OF CONTENTS



	PAGES
INTRODUCTION & WARRANTY	2
SERIAL NUMBER LOCATIONS	6
SAFETY PROCEDURES	7
DECALS	12
CONTROLS	18
MACHINE OPERATION	26
TRANSPORTATION PROCEDURES	30
MAINTENANCE	32
HYDRAULIC SECTION	49
CUTTER HEAD SECTION	59
CUTTER WHEEL SECTION	60
LUBRICATION & COOLANT	61
ELECTRICAL SECTION	62
REPLACEMENT PARTS SECTION	65
MOWER HEAD COMPONENTS	66
STUMP GRINDER HEAD COMPONENTS	68
ATTACHMENT ARM COMPONENTS	70
FRAME & ACCESSORY COMPONENTS	72
FUEL TANK COMPONENTS	74
HYDRAULIC TANK COMPONENTS	75
CAB COMPONENTS	76
HYDRAULIC COMPONENTS	80
SERVICE RECORD	86

NOTICE

ANY PART, PORTION, DESIGN, NUMBER, SPECIFICATION, AND/OR DIMENSION IN THIS MANUAL IS SUBJECT TO CHANGE WITHOUT NOTICE BY THE MANUFACTURER.

INTRODUCTION

The purpose of this manual is to provide the user with specifications and procedures for the operation, maintenance and repair of this BANDIT product. As with any piece of equipment, safety should always be a constant thought while the machine is being operated, serviced or stored. In order to highlight this consideration, the material which addresses safety is preceded by the following signal words:

Signal Word	Likelihood of Occurrence	Degree of Potential Injury or Damage
 DANGER	Will occur if warning is ignored	Severe
 WARNING	Can occur if warning is ignored	Severe
 CAUTION	Will or can occur if warning is ignored	Minor to Severe
NOTICE	Important, but not hazard related	Minor

The equipment is designed and manufactured in accordance with the latest product industry standards. This alone does not prevent injury. It is the operator's responsibility to use good judgement and follow the warnings and instructions as indicated in this manual, on the machine and follow all safety standards per ANSI and OSHA instructions.

WARNING

Improper use of the product can result in severe personal injury. Personnel using the equipment must be qualified, trained and familiar with the operating procedures as defined in this manual, prior to operating the product.

WARNING

It is the responsibility of the owner or employer to insure that the operator is trained and practices safe operation while using and servicing the machine. It is also the owner's responsibility to provide and follow a regularly scheduled preventative maintenance and repair program on the product, using only factory approved replacement parts. Any unapproved repairs or modifications may not only damage the machine and its performance, but could result in severe personal injury. Unapproved repairs or modifications will void warranty and eliminate manufacturer of any liability claims. Consult the equipment manufacturer!!!

Each machine is shipped with a manual, a customer's check sheet on the product, and any available parts & service manuals on component parts not produced by this manufacturer. Additional copies of these manuals and check sheets can be purchased from the manufacturer, or through the dealer. Engine parts, service and maintenance manuals **MUST** be purchased through the engine manufacturer or their dealer.

NOTICE

The producer of this Bandit product reserves the right to make any modifications or revisions to the design or specifications of its machine without advance notice. The producer also reserves the right to change machine and part prices as needed without advance notice.

TYPICAL MACHINE SERIAL NUMBER AND/OR WORK ORDER NUMBER LOCATIONS



1. Serial Number - inside of cab near the top
2. Work Order Number - welded to the frame

NOTICE The engine information is located on the engine block. The clutch information is located on the clutch plate (if equipped).

SAFETY PROCEDURES

⚠ DANGER

The words ⚠ Danger, ⚠ Warning, ⚠ Caution, and Notice are used on the safety decals and throughout this manual, to make you aware of the safety procedures. These procedures are very important, read and obey them.

YOUR SAFETY IS VERY IMPORTANT TO US!

This machine is equipped with safety decals, guards and designs for your protection.

Don't ever take the machine for granted, always be cautious and careful when operating your equipment.

Read and follow all the instructions in your manual thoroughly. Your safety is dependent on your knowledge of how to operate and maintain this machine. You may obtain additional copies of this manual from your Bandit Dealer.

Before operating machine, you must have all potential operators; read and understand manuals and decals, watch the video and follow the recommendations.

Regardless of how hard a manufacturer tries to produce a safe machine, accidents still happen. Normally accidents are caused by people making mistakes. They do not read the manual, they ignore warning decals or do not use lockouts provided for their safety. This normally happens after the person has become accustomed to the machinery. In the initial start up and operation of the machinery, they are cautious, they are very careful because they do not understand the machine.

This equipment is intended for use by personnel who are experienced with similar equipment. Always operate safely. There should be at least two qualified and trained operators at the work site. They should be positioned in safe working locations, following safety procedures and instructions, and aware of each others whereabouts. There should, also, be at least two people on site during maintenance and service procedures in case an accident should occur. Never operate any machine while under the influence of drugs or alcohol.

Keep children, bystanders and animals clear of working area. Never operate equipment that is in need of repair or adjustment.

⚠ DANGER

Do not go near or in-line with the debris field of the stump grinder while in operation. While grinding stumps, the chips and portions of the stump fly from the cutterhead and can cause severe injury.

⚠ DANGER

Before starting the machine, take a minute to check a few things. The machine should be in an area restricted from people passing by. This area around the machine must be free of all objects that can obstruct movement. The machine should be checked for loose tools or foreign objects. All tools not in use should be secured in a tool box.

⚠ WARNING

Operators **must** at all times be located within easy reach of all control and shut-off devices when the unit is running. They must be attentive and prepared to activate the devices.

⚠ DANGER

Torn or loose clothing is more likely to get caught in moving machinery parts. Keep such items as long hair, shirt sleeves, and shirt tails properly contained. Avoid wearing necklaces, rings, watches, and especially neckties while operating this machinery. Make sure the machine is in excellent condition, and all the guards are in place, tight and secure.

Wear all personal protection equipment and follow all safety standards per ANSI and OSHA instructions. Examples of equipment: hard hat, face shield, safety glasses, gloves, ear protection, etc. Always keep a fully charged fire extinguisher with the machine while operating and servicing the machine.

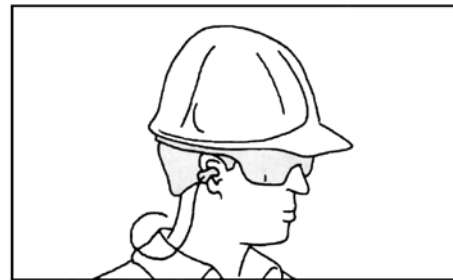

NOTICE

Expensive damage to the Bandit will occur if proper preparation is not taken before welding on the machine. Be sure to disconnect both battery cables and the engine ECM (engine control module) before welding. Follow the specific Engine MFG. instructions for proper welding and grounding procedures, before attempting to weld on the machine. If welding on the machine, do not ground the welder through the machine bearings, ground near work to be performed.

Bandit

SAFETY PROCEDURES

⚠ DANGER

NEVER sit, stand, lay, climb or ride anywhere on this machine while it is running, operating, or in transit. You will be injured.

⚠ WARNING

It is very important after you have operated a new machine for approximately an hour to shut down the machine and recheck all hydraulic fittings. Retighten as needed.

DO NOT GO NEAR HYDRAULIC LEAKS! High pressure oil easily punctures skin causing serious injury, gangrene, or death. **DO NOT** use fingers or skin to check for leaks. Lower load or relieve hydraulic pressure before loosening fittings. Use a piece of cardboard to find leaks. Never use your bare hands.

In cold weather situations let your hydraulic system idle for approximately 15 minutes to allow the system to warm up to operating temperature. Avoid burns from fluid. Hot fluid under pressure can cause severe burns. Relieve all pressure in the system before disconnecting the lines, hoses or performing other work. Allow system to cool down to ambient temperature before opening any coolant or hydraulic oil system.

⚠ WARNING

It is very important after you have operated a new machine for approximately an hour to shut down the machine and recheck all nuts and bolts. It is normal for nuts and bolts to loosen once on a new piece of machinery. If you tighten them now, there is a good possibility they won't loosen again. Certain nuts and bolts must be checked periodically such as cutter teeth bolts and nuts, etc. for torque and fit.

Most of the nuts used on the machine are self locking. After a nut or bolt has been removed five times, it should be replaced to insure proper tightness. This is especially critical on the cutter tooth bolts and nuts!

After the engine is started, let the cutter head turn at the lowest RPM's possible. Listen for any type of noise that is foreign. Any steel on steel noise is foreign. If you hear a noise, stop the engine, find the problem and fix it.

NOTICE

The Bandit has only been run for a short time to test proper hydraulic pressures, possible leaks, etc. The fuel tank will be empty. Fuel is provided through a small auxiliary tank for testing. This immensely helps maintain safety in our manufacturing facility and while shipping.

⚠ DANGER

DO NOT operate this machine indoors! Exhaust fumes can be fatal. Never refuel while the machine is running. Never refuel in the shop or building. Always refuel in a well ventilated area, away from sparks or open flames, **DO NOT SMOKE**. Extinguish all smoking materials. Wipe up all spilled fuel before restarting the engine. Do not fill above 1/2" (12.7 mm) from top of tank.

To obtain the most from your machine, for the least amount of cost, it is a good practice to set up and follow a scheduled preventative maintenance program. It will eliminate many possible problems and down time.

⚠ WARNING

Never use jumper cables during freezing temperatures. Haul the machine inside and allow the battery time to warm up. If the machine must be started outside, inspect the battery acid for ice formation. Explosion will occur with a frozen battery. If the machine is going to be operated in excessively cold conditions, a larger cold cranking amp battery may be needed to insure proper and prompt starting. Never use jumper cables in a confined or unventilated area. Battery acid fumes are explosive. Battery acid can cause severe burns. Never expose an open flame or spark near the battery. Keep all burning materials away from the battery. When servicing the battery, shield eyes and face, and do not smoke. Service in a well ventilated area.

⚠ DANGER

AVOID EQUIPMENT AND PERSONAL INJURY WHEN TILTING THE CAB.



DO NOT ALLOW ANYONE IN THE CAB WHEN IT IS TILTING OPEN OR CLOSED.

DO NOT ALLOW ANYONE NEAR THE CAB WHEN IT IS TILTING OPEN OR CLOSED.

DO NOT TILT THE CAB WITH THE CAB DOORS OPEN. SECURE IN CLOSED POSITION.

BE AWARE AND AVOID ALL PINCH POINTS OF THE CAB WHEN OPENING OR CLOSING.

ALWAYS OPERATE THE CAB TILT SLOWLY AND CAREFULLY.

ALWAYS SECURELY BOLT THE CAB IN THE "DOWN" POSITION DURING OPERATION OR TRANSPORT.

ALWAYS USE THE CAB CYLINDER LOCKS WHEN THE CAB IS TILTED.

SAFETY PROCEDURES

DANGER

Never work under or around the cutter head without first disengaging the clutch, turning off the engine, waiting for the cutter head to come to a complete stop, turning the battery disconnect switch off, and make sure the ignition key is in your possession. Make sure the cutter head is set on the ground or securely blocked up and also chained before doing any work around or under it.

NOTICE

Do not attempt to start the engine or engage the engine PTO (power-take-off) system on this machine if the cutter head is jammed or frozen in place. If you do, you will damage or ruin the drive belts and/or the PTO which will not be covered under warranty and will cost you down time and money.

DANGER

Your machine may or may not be equipped with a clutch. Depending on the options ordered, some machines are direct drive.

Do not work on the machine if the engine is running with the clutch disengaged. A clutch can self engage if either the pilot or throw-out bearing happens to seize to the main output shaft.

There are various types of clutches (PTO's) available for this type of equipment. Make sure to study the original clutch manufacturer's manual that is provided with the machine and follow its instructions for operation, service, and adjustments. Some styles require clutch engagement to be maintained so that it takes a lot of force, others will require very little force, and some are push button, electric, manual lever, or hydraulic activation. Each different style clutch (PTO) is a very expensive item that will fail if not correctly maintained and adjusted. It will be quite costly if a few minutes are not taken daily, weekly, and monthly to keep the clutch serviced as required.

The operator must take care in the engagement and disengagement of the clutch, engine RPM should always be below 1000 RPM. When the engine has sufficiently warmed up, slowly push the handle all the way in gear until it locks into position securely. After engagement raise engine RPM to full throttle. Engaging and disengaging the clutch at high engine RPM will quickly and excessively wear out clutch plates as well as bearings. Refer to clutch manufacturer's manual for proper service and operation.

WARNING

DO NOT operate this machine unless all hydraulic control devices operate properly. They must function, shift and position smoothly and accurately at all times. Faulty controls can cause personal injury!

DANGER

Before attempting any type of maintenance disengage clutch (if equipped), turn off engine, wait for the cutter head to come to a complete stop, turn the battery disconnect to the off position, and make sure the ignition key is in your possession.

DANGER

Never grind/mow any materials that might contain wires, stones, nails, or other metal objects which may damage the teeth and become dangerous projectiles. Remove all rocks and stones from work area.

DANGER

Do Not start to grind/mow unless you are completely sure there are not any power lines, water lines, sewer lines, phone lines, etc. in the area above or below ground level where you are working.

DANGER

Avoid power lines. Electrocutation is possible if the machine touches a power line. Take the following precautions. Keep the machine at least 10 feet (3 meters) from electric lines. If the machine contacts an electric line stay away from the machine.

DANGER

Avoid moving parts. Keep hands, feet, and clothing away from power driven parts. Keep all guards and shields in place and properly secured.

DANGER

Never go near cutter head or teeth while engine is running or cutter head is coasting to a stop.

DANGER

Keep the machine in good condition. Be sure the machine is in good operating condition and that all safety devices, including guards, shields, and deflection chains are installed and functioning properly. Visually inspect the machine daily before starting the machine. Refer to the "Daily Start Up & Maintenance". Make no modifications to your equipment unless specifically recommended or requested by Bandit Industries Inc.

WARNING

Check laws and regulations. Know and obey all federal, state, and local laws and regulations that apply to your work situation and the transportation of a machine this size.

Bandit

SAFETY PROCEDURES

⚠ DANGER

Stay back 300 feet (90 m) in all directions from the machine while in operation. Always stop and warn anyone from entering the 300 foot (90 m) radius debris field around the machine. Failure to do this could result in severe injury. Wood chips, rocks, and other debris flying from the cutter head can be very dangerous.

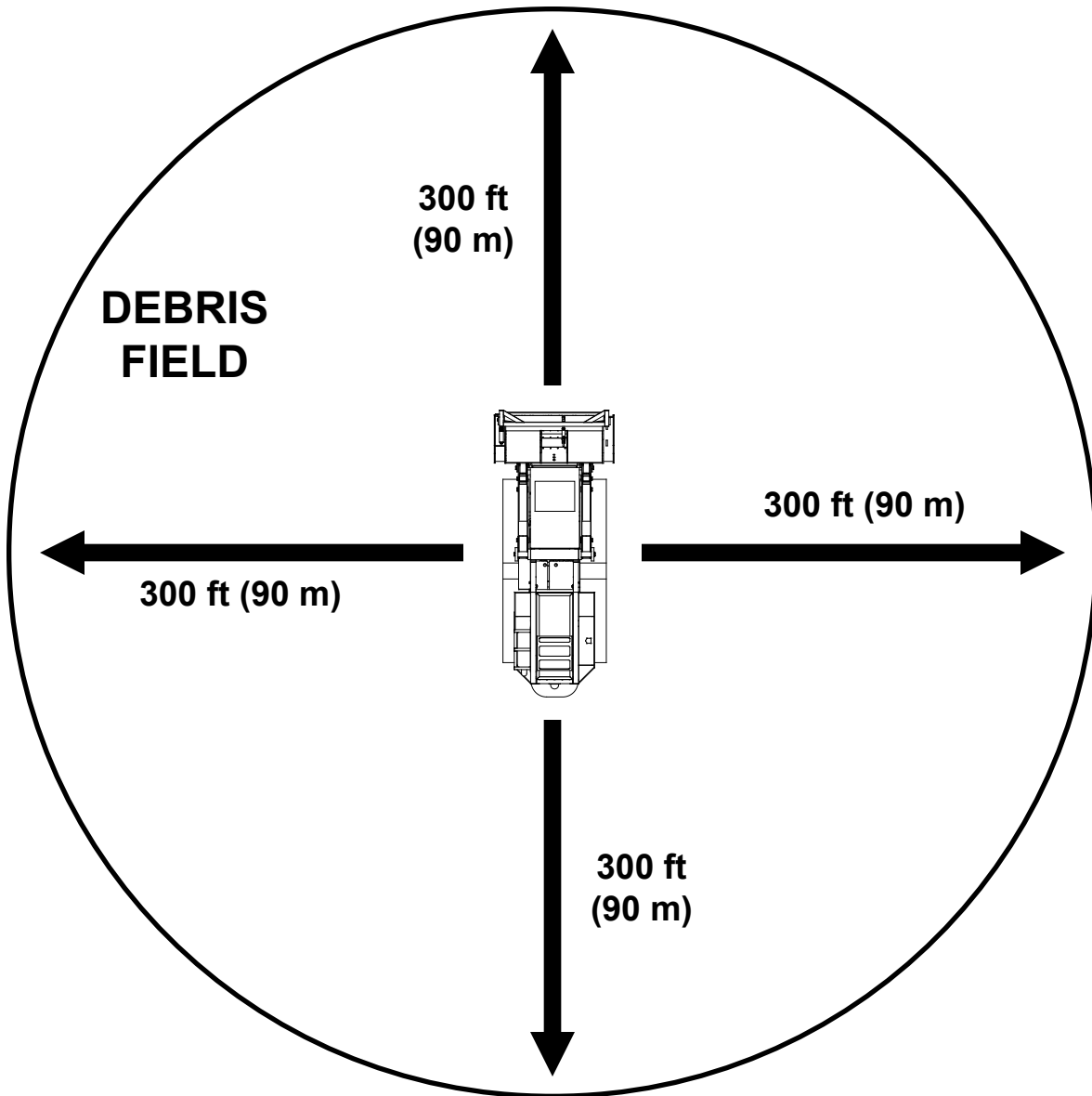

SAFETY PROCEDURES

IF MACHINE IS EQUIPPED WITH A SELF PROPELLED UNDERCARRIAGE

Machines equipped with undercarriage tracks are shipped with a manual from the track manufacturer. Refer to it for service, operation, and safety information.

⚠ WARNING

Do not attempt to operate the machine on an ascending or descending slope of more than 25° or 46% or a side slope of more than 17° or 30%, it is Dangerous and could be Fatal. This is the maximum slope grade the machine can be operated on if the hydraulics, self propelled undercarriage, and engine are running at maximum performance and good traction is sustained.

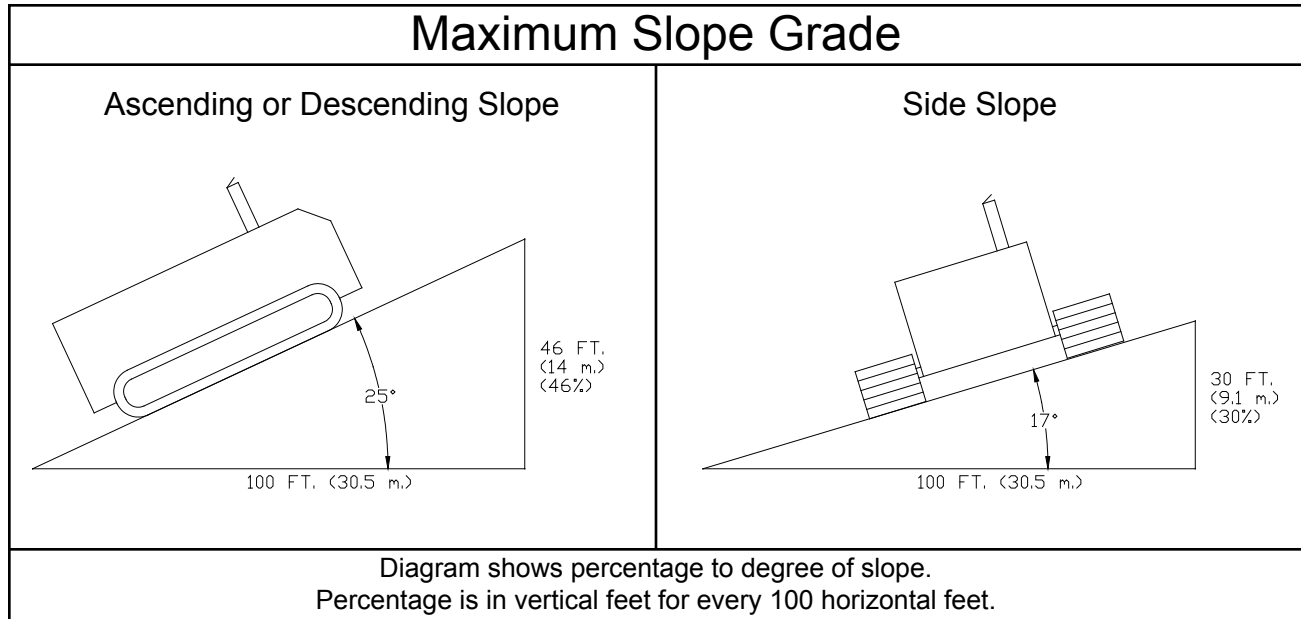

⚠ WARNING

Any increase from the specified maximum operating angles may cause loss of lubrication function and damage the engine.

⚠ DANGER

The machine should never be parked on a slope at any time. The machine can coast or creep causing equipment and/or personal injury.

⚠ DANGER

Make sure everyone is clear of machine before moving the machine. Stay clear of undercarriage travel system when the machine is moving.

⚠ DANGER

DO NOT entangle feet or hands in undercarriage travel system.

⚠ DANGER

Use **EXTREME CAUTION** when traveling over non-level surface! This machine can tip over or tip backwards on non-level surface. You will cause engine damage, machine damage and possible personal injury!

⚠ DANGER

NEVER sit, stand, lay, climb or ride anywhere on this machine while it is running, operating, or in transit. You will be injured.

Bandit

DECAL LOCATIONS

Decal locations may vary, these are general locations.

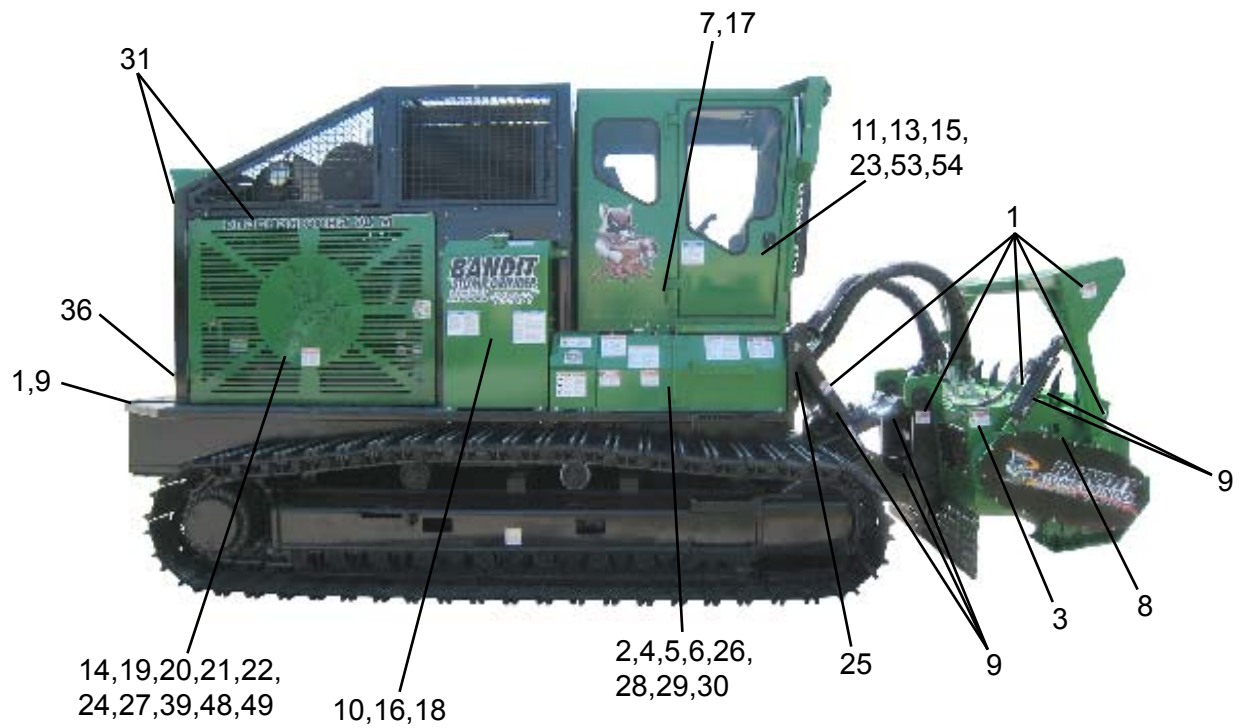
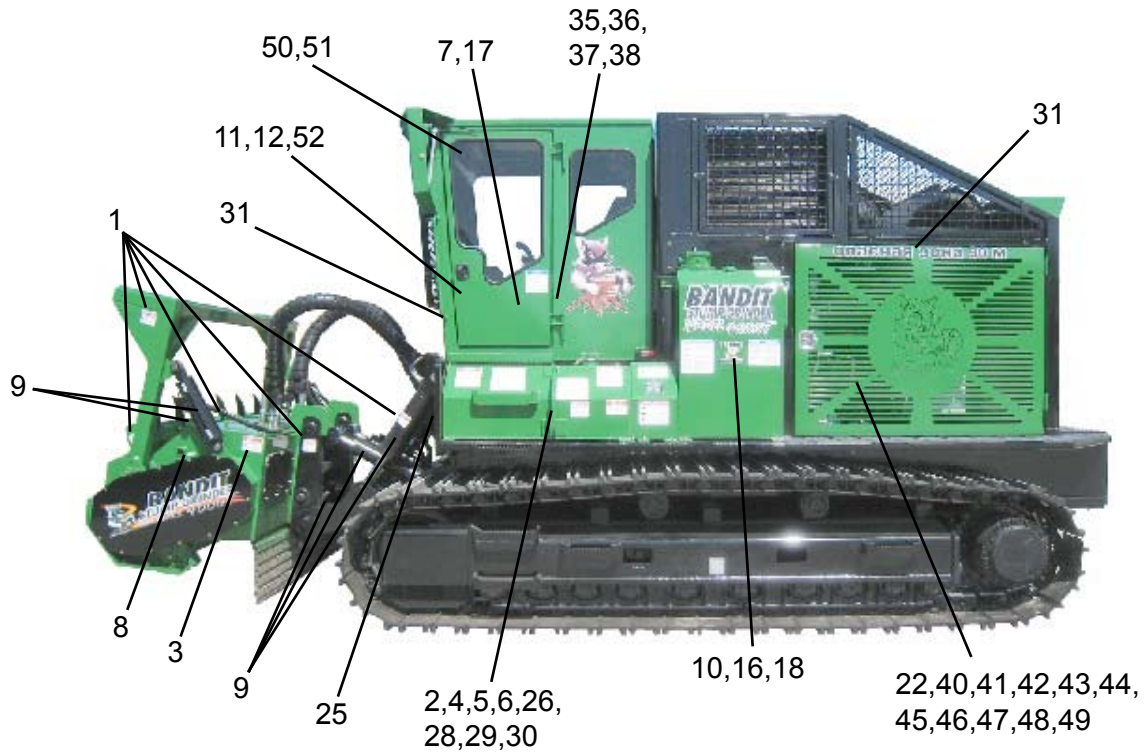

DECAL LOCATIONS

Modifications and/or additions of decals to this list will happen.
Consult machine dealer or manufacturer for most current decal package.

LOCATION	NUMBER	DESCRIPTION
1.	SPD-02	Moving Parts Keep Hands...
2.	SPD-19	...Minimum 10 Feet Away From Tracks...
3.	SPD-20	Flying Objects Stand Clear...
4.	SPD-30	Do Not Sit, Stand, Lay, Climb or...
5.	SPD-36	...Debris Field...
6.	SPD-45	Avoid...Injury When Tilting Cab
7.	SPD-49	...Cab Is Tilted...Cylinder Locks Must Be In Place...
8.	INST-12	Grease Daily Arrow
9.	INST-16	Grease Weekly Arrow
10.	INST-53	Hydraulic Oil...Hydrex XV...
11.	INST-110	Window Washing Instructions...
12.	INST-174	Left Joystick Controls
13.	INST-175	Right Joystick Controls
14.	INST-189	Power Box Fuse & Relay Panel
15.	INST-190	Cab Fuse Panel
16.	N-02	Maintain Lubrication...
17.	SPN-06	Decal Maintenance..
18.	N-14	Do Not Start To Weld...Unless...
19.	N-16	24 Volt Circuit
20.	N-17	Battery Disconnect Switch Off (Arrow) On
21.	N-30	Must Wait 45 Seconds Before Turning Off Battery...
22.	N-36	12 Volt Circuit
23.	N-40	Decrease Cutter Head Rpm...
24.	N-42	Cab Tilt Power Disconnect Switch Off (Arrow) On
25.	SPW-01	Do Not Go Near Oil Leaks...
26.	SPW-02	Combustible Liquid...Diesel Fuel Only...
27.	SPW-04	Frozen Battery Will Explode...
28.	SPW-06	Do Not Attempt...Slope Of More Than...
29.	SPW-08	Wear Eye & Personal Protection...
30.	SPW-11	Do Not Leave Unit Parked On A Slope...
31.	--	STAY BACK 300 FT (90 m)
32.	900-8901-39	Basic Safety Decal Kit (Options may require additional decals)
33.	900-8900-65	Bandit Model 4000T Logo Decal Kit
34.	900-8901-42	Bandit Model 5000T Logo Decal Kit

NOTICE

Some decals are for optional equipment. Decal locations may vary, these are general locations.
If any decals become damaged, replace immediately.

Bandit

DECAL LOCATIONS

Decal locations may vary, these are general locations.

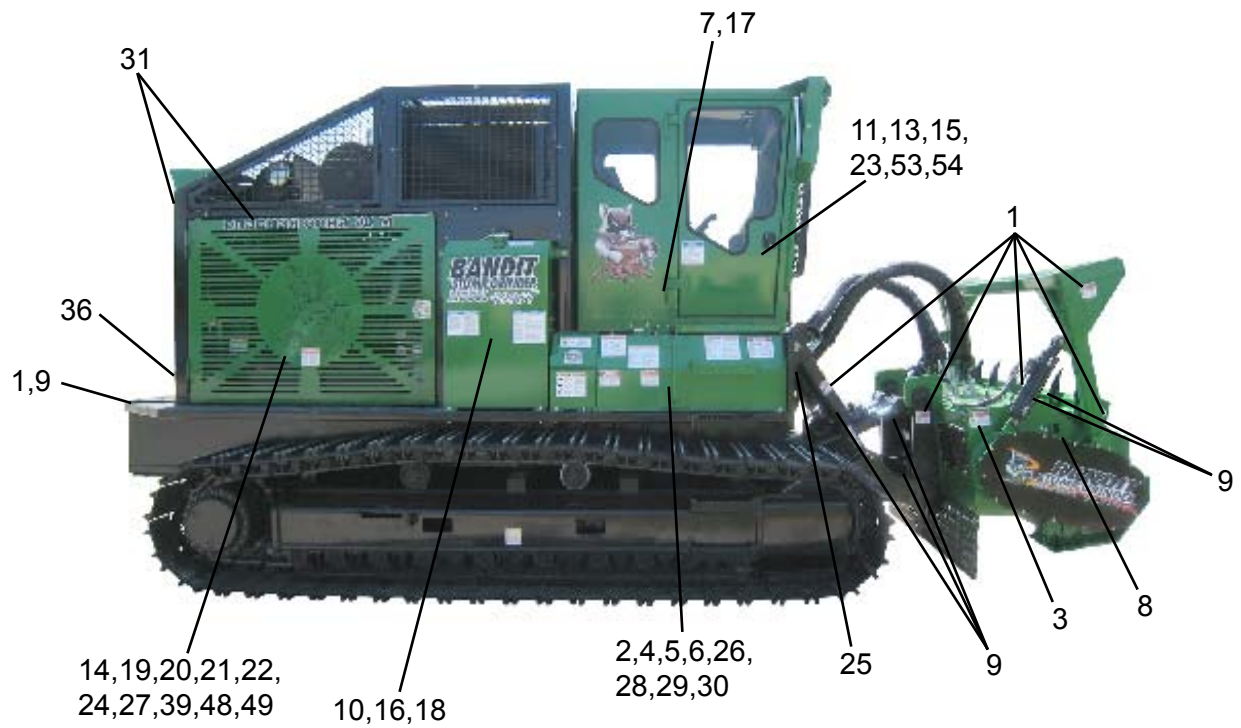
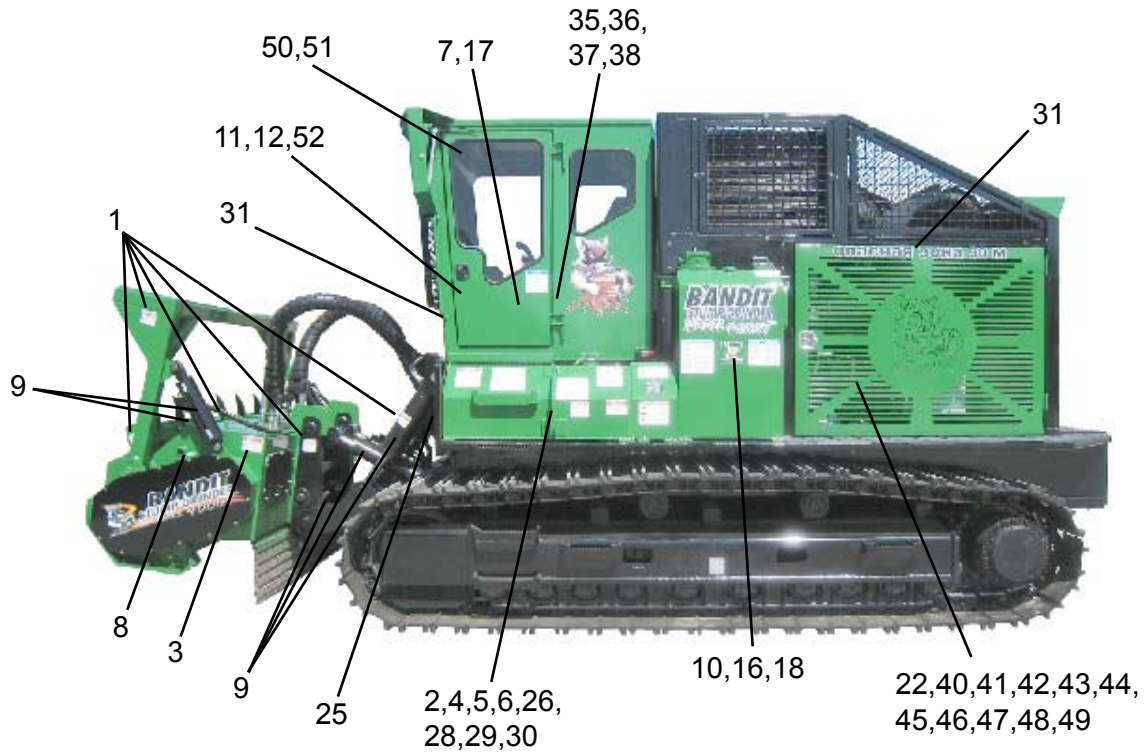

DECAL LOCATIONS

Modifications and/or additions of decals to this list will happen.
 Consult machine dealer or manufacturer for most current decal package.

LOCATION	NUMBER	DESCRIPTION
35.	OL-06	12 Volt Power Outlet
36.	OL-07	Winch Tether Jack
37.	OL-08	Starting Preheater Controls & Timer
38.	OL-09	Manual Fan Purge
39.	OL-10	Cab Power Box
40.	OL-11	Cab Tilt Power Unit
41.	OL-12	Left Cutter Head Pressure
42.	OL-13	Right Cutter Head Pressure
43.	OL-14	Left Cutter Head Charge Pressure
44.	OL-15	Right Cutter Head Charge Pressure
45.	OL-16	Left Track Charge Pressure
46.	OL-17	Right Track Charge Pressure
47.	OL-18	Auxiliary Pressure
48.	OL-19	Left Accumulator Pressure
49.	OL-20	Right Accumulator Pressure
50.	OL-26	Upper Control Panel
51.	OL-27	Mirror Controls
52.	OL-28	Ignition Panel
53.	OL-29	Data Link
54.	OL-30	Plus One Fault Alarm
55.	900-8901-40	Overlay Decal Kit

NOTICE

Some decals are for optional equipment. Decal locations may vary, these are general locations. If any decals become damaged, replace immediately.

DECALS

Decals located on your Bandit equipment contain useful information to assist you in operating your equipment safely. Some of the decals on your machine and their location are shown in this section.

It is very important that all decals remain in place and in good condition on your machine. Please follow the care and instructions given below:

- 1) You should use soap and water to keep your decals clean. Never use mineral spirits or any other abrasive cleaners.
- 2) Replace immediately any missing or damaged decals. The location the decal is going to be applied to must be clean and dry, and at least 40°F (5°C) before applying decal.
- 3) When the need arises to replace a machine component with a decal attached, be sure and replace the decal.
- 4) Replacement decals are available, and can be purchased from the manufacturer or your Bandit Dealer.
- 5) Peel back about half of the backer paper on the decal. Position it on the flat, dry, clean surface so it is smooth and secure. Peel off the remainder of the backer paper as you continue to stick the decal on the surface.
- 6) Rub decal from the center outward to remove air bubbles and to secure contact.
- 7) Combination English / Spanish decals are typically standard. Other foreign language decals are available and may be purchased. Mail translated decals required to Bandit Industries, Inc.

EXAMPLES:



DECALS

! DANGER



**FLYING OBJECTS
STAND CLEAR
OR YOU WILL BE
INJURED!**

! DANGER



**MOVING
PARTS!**



**KEEP HANDS
CLEAR!**

! DANGER

**AVOID EQUIPMENT AND
PERSONAL INJURY WHEN
TILTING THE CAB.**



**DO NOT ALLOW ANYONE IN THE CAB WHEN IT IS TILTING
OPEN OR CLOSED.**

**DO NOT ALLOW ANYONE NEAR THE CAB WHEN IT IS
TILTING OPEN OR CLOSED.**

**DO NOT TILT THE CAB WITH THE CAB DOORS OPEN.
SECURE IN CLOSED POSITION.**

**BE AWARE AND AVOID ALL PINCH POINTS OF THE CAB
WHEN OPENING OR CLOSING.**

ALWAYS OPERATE THE CAB TILT SLOWLY AND CAREFULLY.

**ALWAYS SECURELY BOLT THE CAB IN THE "DOWN"
POSITION DURING OPERATION OR TRANSPORT.**

**ALWAYS USE THE CAB CYLINDER LOCKS WHEN THE
CAB IS TILTED.**

! WARNING



DO NOT GO NEAR LEAKS!

- Pressured oil easily punctures skin causing injury, gangrene or death.
- Seek immediate medical care.
- Do not use finger or skin to check for leaks.
- Remove hydraulic pressure or load before loosening fittings.

! WARNING



**WEAR EYE & PERSONAL
PROTECTION EQUIPMENT**

Wear all personal protection equipment and follow all safety standards per ANSI and OSHA instructions.

JOYSTICK FUNCTIONS WITH MOWER ATTACHMENT

LEFT JOYSTICK

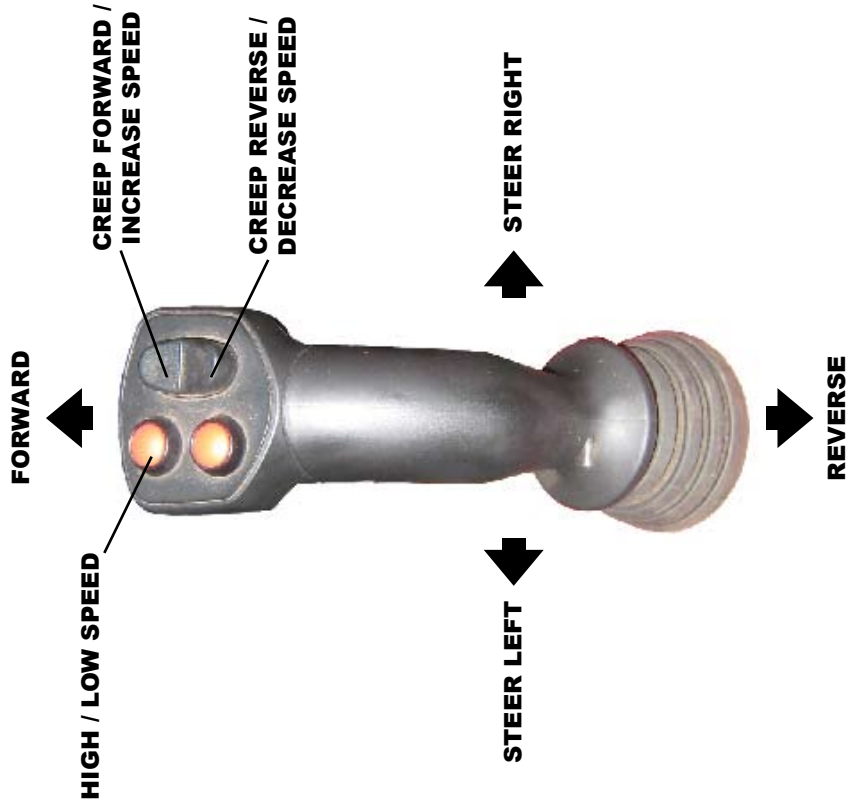

RIGHT JOYSTICK

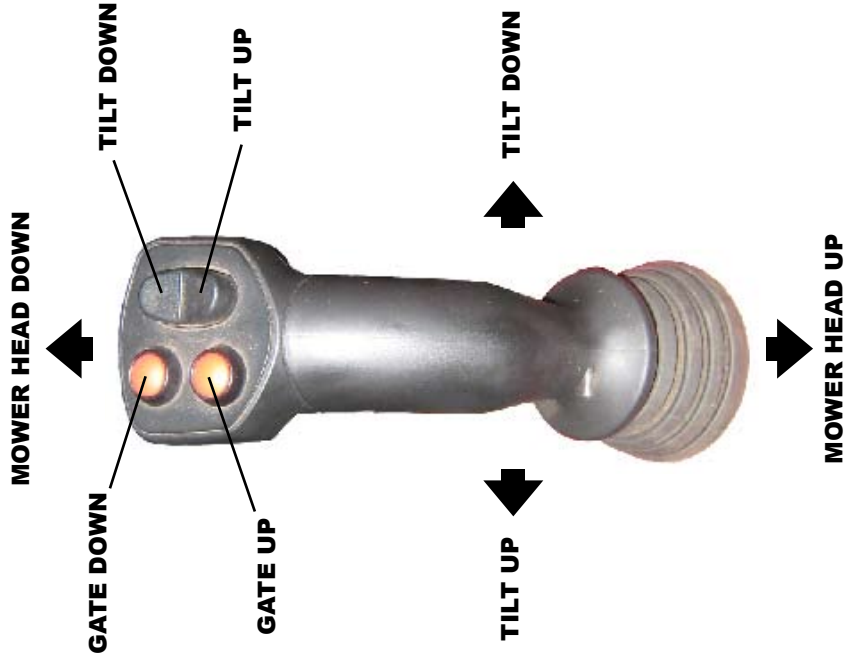

JOYSTICK FUNCTIONS WITH STUMP GRINDER ATTACHMENT

LEFT JOYSTICK

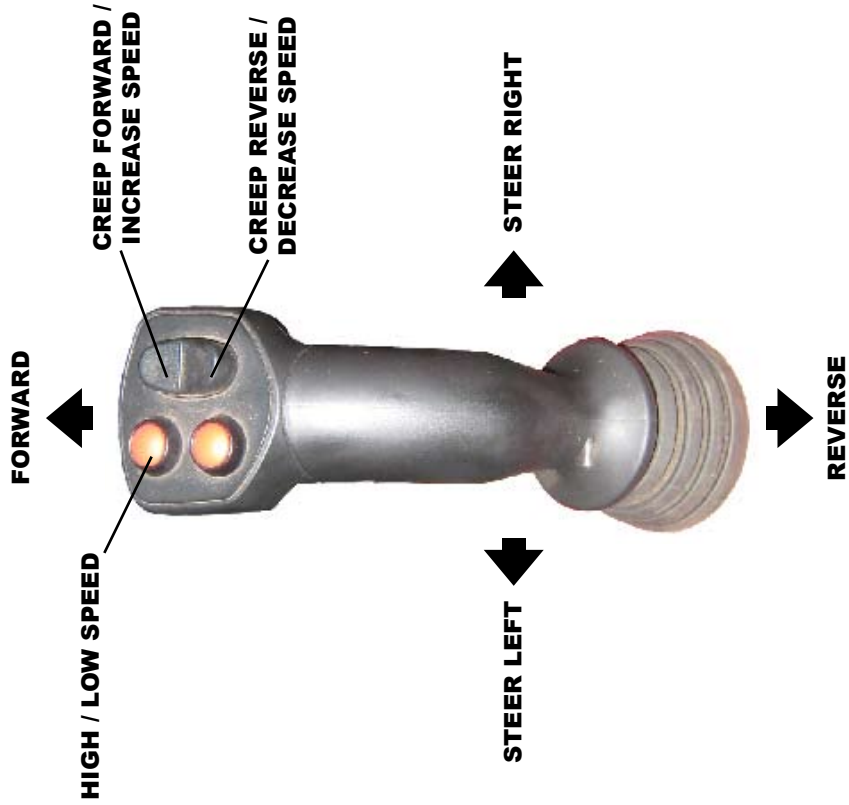

RIGHT JOYSTICK

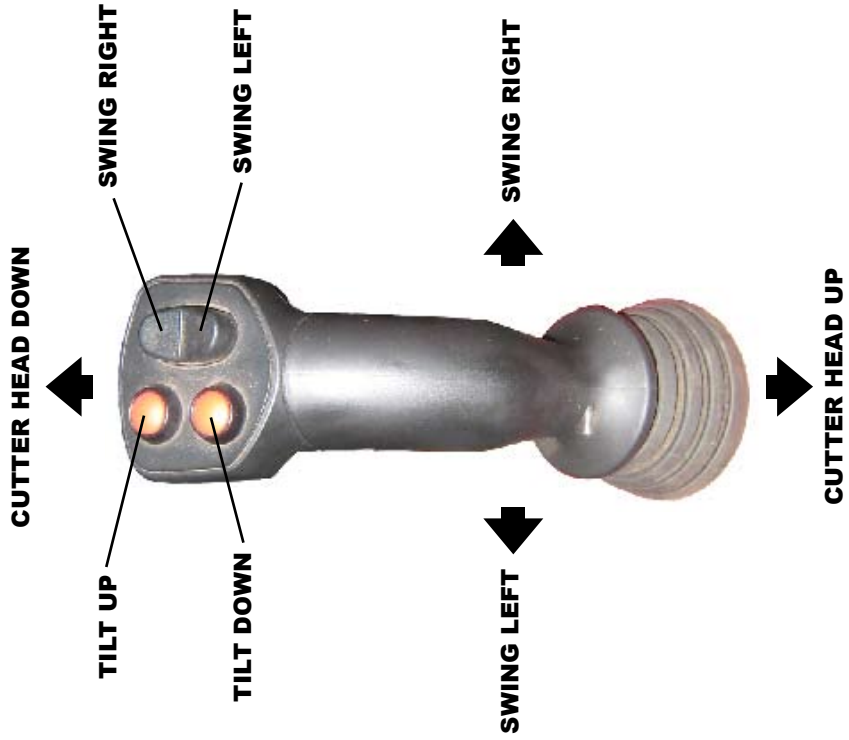

CAB CONTROLS

Located between the right hand cab door and the seat.

Located between the left hand cab door and the seat.



12 Volt Power Outlet

Engine Data Link

Manual Fan Purge Button

Winch Tether Jack

Fuse Panel

Right side of cab.

Left side of cab.



Heater and air conditioner controls.



Starting preheater controls and timer.

CAB CONTROLS

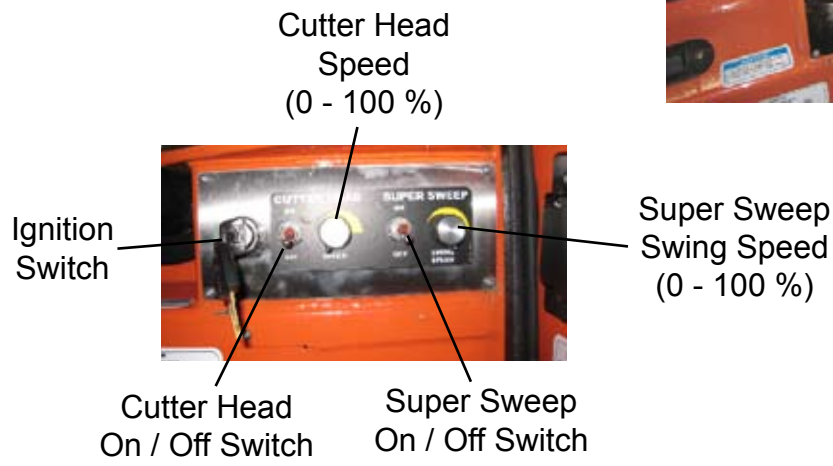
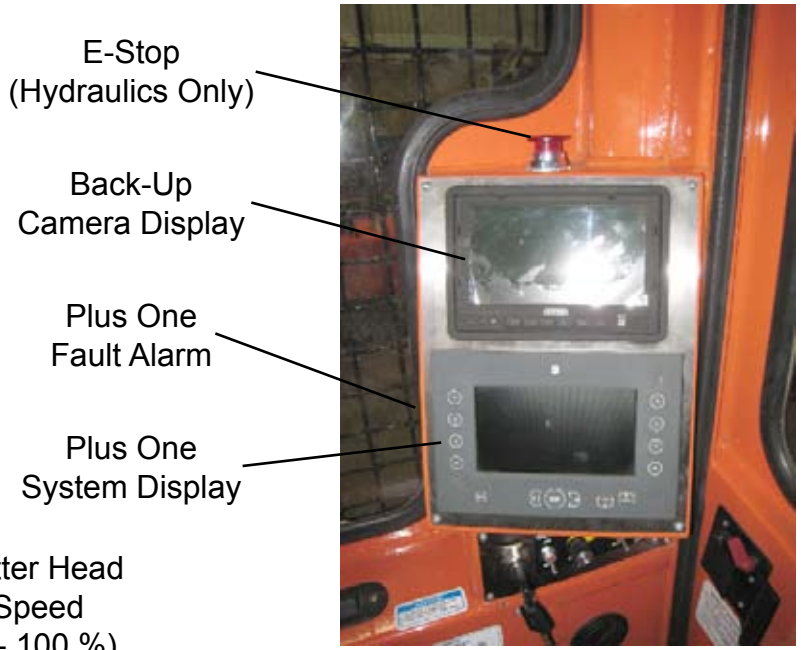
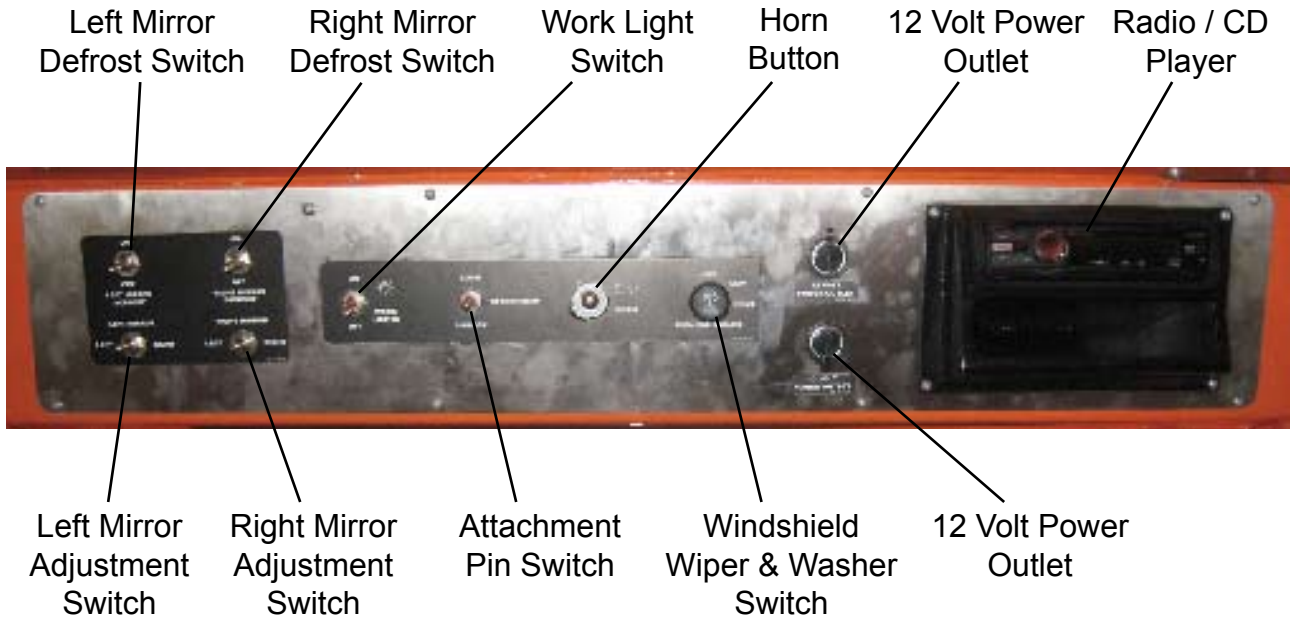

ROAD (LEFT) SIDE OF ENGINE

Hydraulic diagnostic
gauges

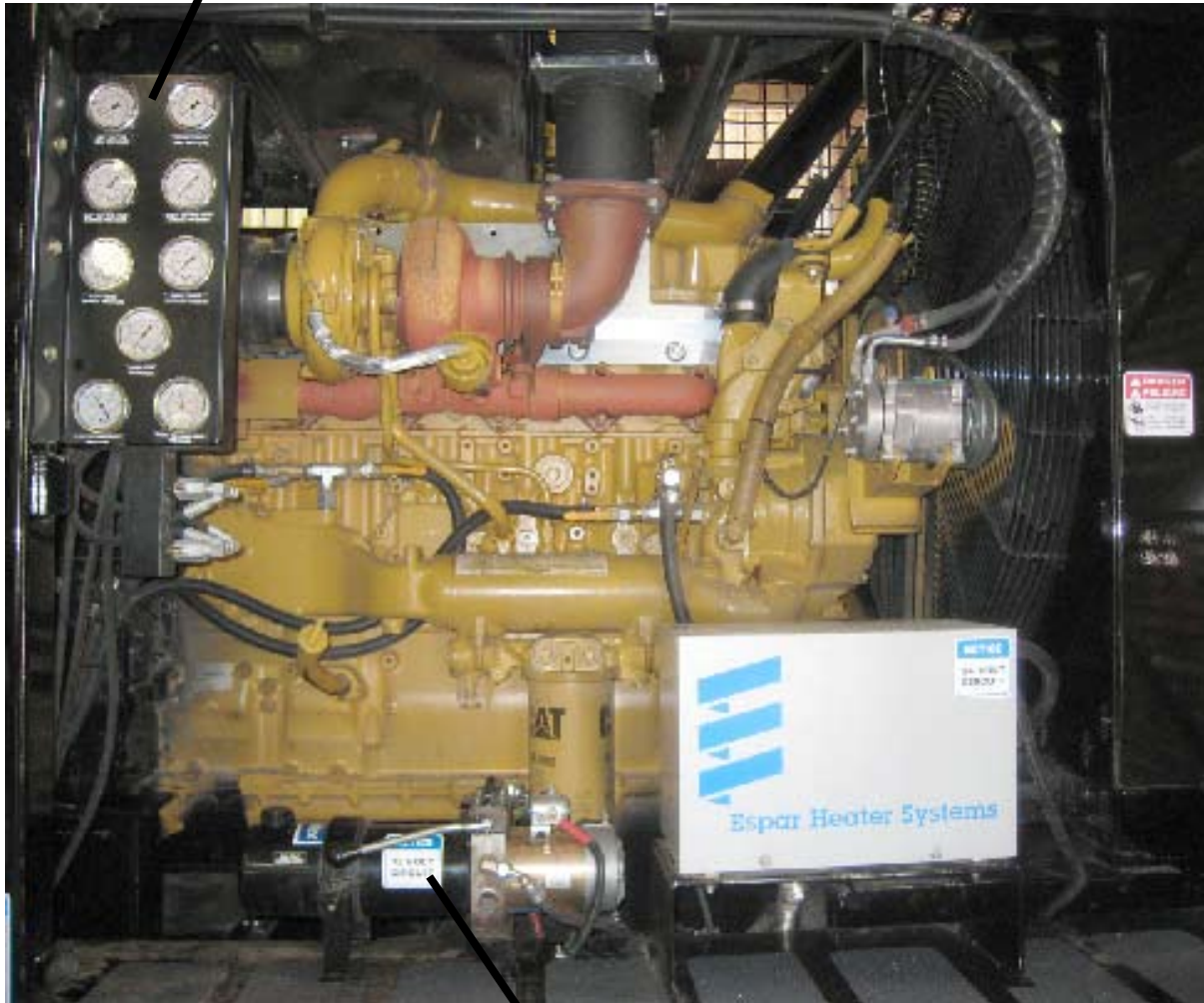

Cab tilt pump
and valve

CURB (RIGHT) SIDE OF ENGINE



Reversing fan controller (the switch is located in the cab).

12 volt circuit battery disconnect switch

Power box fuse & relay panel

24 volt circuit breaker

Cab power box



24 volt circuit battery disconnect switch

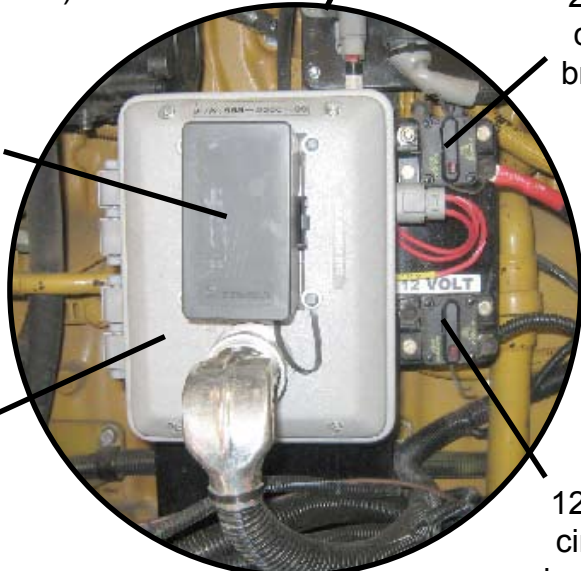

12 volt circuit breaker

NOTICE Parts may not be exactly as shown.

WINCH



The winch tether can be plugged into the rear of the machine near the winch or in the cab.



The winch tether jack in the cab of the machine. Located between the left hand cab door and the seat.



The winch tether jack at the rear of the machine. Located at the lower right hand corner of the engine radiator door.

OPERATOR CHAIR ADJUSTMENTS



1. Twist the adjustment knob and lean back or lean forward to move the seat back to the desired position.
2. Press or pull the lever to adjust the bottom of the seat.
3. Press the button to release the lumbar.
4. Squeeze the bulb to pump up the lumbar.
5. Pull the lever to allow the chair to slide back and forth to the desired location.
6. Adjust the seat suspension to the operator's weight.
7. Pull the lever to allow the pedestal and chair to slide back and forth to the desired location.

MACHINE OPERATION - MOWER

DANGER

DO NOT operate this machine unless all hydraulic control devices operate properly. They must function, shift and position smoothly and accurately at all times. Faulty controls can cause personal injury!

DANGER

Never grind/mow any materials that might contain wires, stones, nails, or other metal objects which may damage the teeth and become dangerous projectiles. Remove all rocks and stones from work area.

DANGER

Do **Not** start to grind/mow unless you are completely sure there are not any power lines, water lines, sewer lines, phone lines, etc. in the area above or below ground level where you are working.

DANGER

Avoid power lines. Electrocutation is possible if the machine touches a power line. Take the following precautions. Keep the machine at least 10 feet (3 meters) from electric lines. If the machine contacts an electric line stay away from the machine.

WARNING

Stay back 300 feet (90 m) in all directions from the machine while in operation. Always stop and warn anyone from entering the 300 foot (90 m) radius debris field around the machine. Failure to do this could result in severe injury. Wood chips, rocks, and other debris flying from the cutter head can be very dangerous.

- Check all fluids before starting the machine.
- Make sure to go through the daily start-up and maintenance procedures before operating the machine.
- Make sure the cutter speed switch is in the "off" position.
- Start engine at idle speed and allow for sufficient time for oil to circulate before proceeding.
- Test all controls for proper operation.
- Avoid transversing slopes.

Pushworking - making the first initial passes

Lift the cutter head up and tilt the mower up so that the cutter head is as exposed as possible.

Open the gate or trap door.

Drive the machine into the work area and start mowing/grinding.

Lower the cutter head as allowed.

Move the machine slowly back and tilt the cutter head down as it approaches the ground.

Watch the engine RPM's and adjust the machines mowing/grinding depth and travel speed as needed.

Do not allow the engine to stall.

Pullworking - grinding what you have taken down with the first initial passes

Position the cutter head slightly off the ground.

Close the gate or trap door as needed to contain or control the debris.

Back the machine back over the area that was mowed/ground.

Watch the engine RPM's and adjust the machines mowing/grinding depth and travel speed as needed.

Do not allow the engine to stall.

MACHINE OPERATION - MOWER

Removing Stumps - still in the ground

To grind stumps that are still in the ground, move the machine back and forth while slowly lowering the cutter head.

Grinding stumps works best in the forward direction.

Removing Stumps - loose and out of the ground

To grind stumps that are loose and out of the ground, with the front of the mower tilted up, lower the cutter head down on top of the stump.

Do not tilt the mower up in the back because the stump may be flung into the machine.

Loose stumps should be chased or pinned in a hole in the ground.

Keep lowering the cutter head down on the stump, be careful not to fling the stump under the machine as the size decreases.

Finishing - after all initial passes and stumps have been removed

Position the cutterhead with the mower foot pads on the ground.

Close the gate or trap door

Back the machine back over the area that was mowed/ground.

The slower the machine is driven, the finer the material that is left on the ground.

FOOT PAD ADJUSTMENT

⚠ DANGER

Before attempting any type of maintenance disengage clutch (if equipped), turn off engine, wait for the cutter head to come to a complete stop, turn the battery disconnect to the off position, and make sure the ignition key is in your possession.

⚠ DANGER

Never work under or around the cutter head without first disengaging the clutch, turning off the engine, waiting for the cutter head to come to a complete stop, turning the battery disconnect switch off, and make sure the ignition key is in your possession. Make sure the cutter head is set on the ground or securely blocked up and also chained before doing any work around or under it.

⚠ DANGER

Never go near cutter head or teeth while engine is running or cutter head is coasting to a stop.

- 1) Read all instructions and Dangers before starting procedures.
- 2) Lift the cutter head off the ground and block it. Do not rely on the hydraulics to hold the cutter head off the ground.
- 3) Follow all pre-maintenance shut down procedures.
- 4) Remove all eight (8) bolts in the foot pad.
- 5) Position the foot pad assembly to the desired position for the specific application. The closer the cutter head is to the ground the finer the debris/mulch.
- 6) Put the bolts back in and tighten.
- 7) Repeat procedure to the other foot pad assembly.

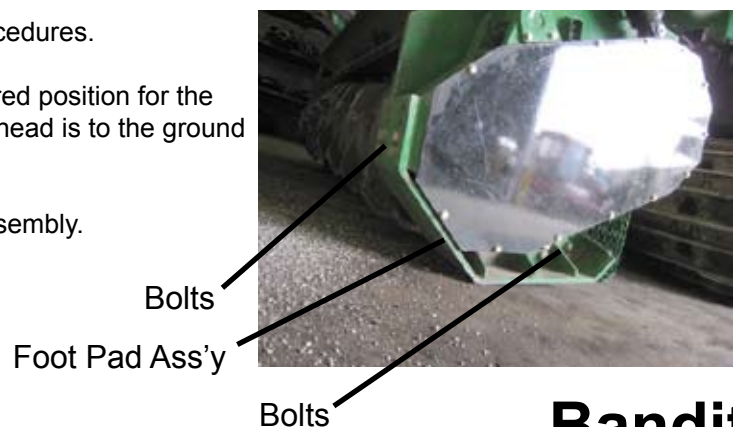

Bandit

MACHINE OPERATION - STUMP GRINDER

DANGER

DO NOT operate this machine unless all hydraulic control devices operate properly. They must function, shift and position smoothly and accurately at all times. Faulty controls can cause personal injury!

DANGER

Never grind/mow any materials that might contain wires, stones, nails, or other metal objects which may damage the teeth and become dangerous projectiles. Remove all rocks and stones from work area.

DANGER

Do **Not** start to grind/mow unless you are completely sure there are not any power lines, water lines, sewer lines, phone lines, etc. in the area above or below ground level where you are working.

DANGER

Avoid power lines. Electrocutation is possible if the machine touches a power line. Take the following precautions. Keep the machine at least 10 feet (3 meters) from electric lines. If the machine contacts an electric line stay away from the machine.

WARNING

Stay back 300 feet (90 m) in all directions from the machine while in operation. Always stop and warn anyone from entering the 300 foot (90 m) radius debris field around the machine. Failure to do this could result in severe injury. Wood chips, rocks, and other debris flying from the cutter head can be very dangerous.

- Check all fluids before starting the machine.
- Make sure to go through the daily start-up and maintenance procedures before operating the machine.
- Make sure the cutter speed switch is in the "off" position.
- Start engine at idle speed and allow for sufficient time for oil to circulate before proceeding.
- Test all controls for proper operation.
- Avoid transversing slopes.

Position machine at stump with cutter wheel a slight distance away from stump.

Raise cutter wheel clear of stump.

Engage the cutter wheel.

Increase engine RPM to full.

Test the controls for proper operation, speed, and unobstructed movement.

The cutter wheel swing speed should be adjusted to a rate that will allow cutter wheel to pass through stump smoothly. If jerking, bouncing or significant drops in engine speed occur, swing rate is too rapid and must be decreased.

Travel speed should be adjusted to a rate that will allow cutter wheel to approach stump smoothly. If cutter wheel is approaching stump quickly, travel speed is too rapid and must be decreased.

Lower the spinning cutter wheel to the stump and make a few light passes at the stump to get a feel for the cutting action.

Gradually increase cutting action and work away at the stump by swinging cutter wheel left-to-right-to-left through stump in a sideways motion. Smooth, effortless cutting lengthens machine life, minimizes down time and is more profitable in the long run.

Continue cutting stump by adjusting cutting wheel progressively lower until stump is cut well below ground level.

Swing cutter wheel clear of stump and position machine closer to stump for next series of passes and continue cutting.

Continue in this manner until stump has been removed.

Larger stumps may require repositioning machine to remove complete stump.

Raise cutter wheel clear of stump and return to center position.

Bandit

MACHINE OPERATION - STUMP GRINDER

Proceed to the next stump.

Reduce engine speed to idle and disengage cutter wheel. **DO NOT TURN OFF MOTOR.** Engine should be allowed to cool slowly at idle for 3-5 minutes to avoid damage.

DO NOT ENGAGE OR DISENGAGE CUTTER HEAD AT A HIGH ENGINE SPEED. Damage to the machine will occur.

Turn off engine.

Allow cutter wheel to come to a complete stop before inspecting.

CUTTING AREA - STUMP GRINDER

⚠ DANGER

For optimum performance, the stump should be cut with the portion of the cutter wheel shown below. **NEVER UNDERCUT THE STUMP.** Undercutting the stump may cause severe kickback, vibration and component damage. **NEVER CUT THE STUMP FROM THE TOP.** The cutter wheel will throw debris up and toward the operator, instead of down and under the machine.

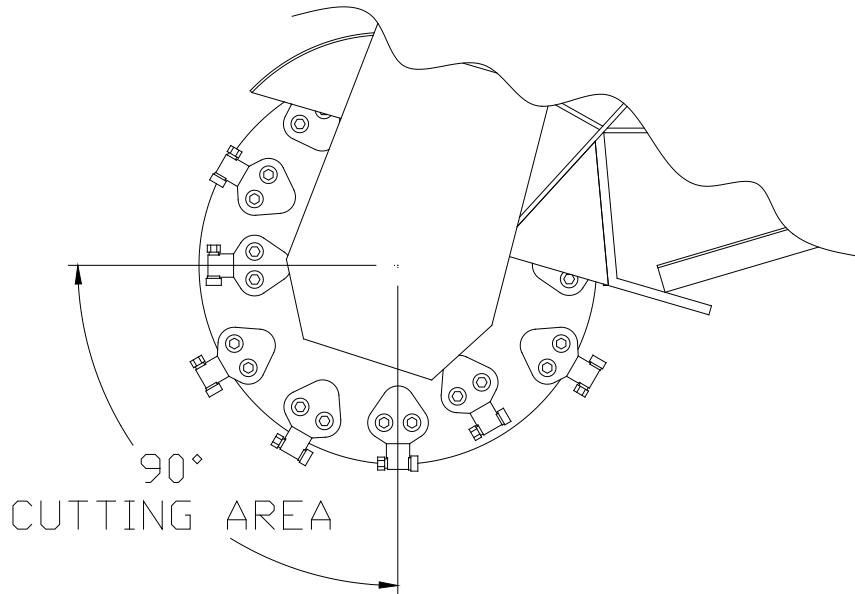

⚠ DANGER



**FLYING OBJECTS
STAND CLEAR
OR YOU WILL BE
INJURED!**

Transportation Procedures

WARNING

BEFORE TRANSPORTING THE MACHINE, INSPECT AND CONFIRM THE FOLLOWING STEPS:

- 1) The trailer has a cargo weight rating capacity for the weight of the stump grinder. The combined weight of the trailer and the stump grinder can not exceed the load capacity of the tires, axles, hitch coupler system or the GVWR (Gross Vehicle Weight Rating) of the trailer.
- 2) The towing vehicle is rated for and has the towing capabilities to haul the stump grinder package (includes the stump grinder and a trailer). The towing vehicle must be mechanically sound and capable of handling the towing job.
- 3) The hitch on the towing vehicle and the coupler on the trailer is a perfect match in size, type, and needed capacity.
- 4) Both the towing hitch and the coupler are in good mechanical and wear condition, that they are joined together securely, and the coupler/hitch is locked in place.
- 5) The safety chains have the correct capacity for the equipment being towed.
- 6) The safety chains are crossed under the coupler/hitch then securely attached to the towing vehicle. The safety chains are long enough to not restrict the turning movement, but short enough to not drag on the road.
- 7) The electrical plug-in on the towing vehicle and the trailer are wired for the same functions and they fit securely together. The plug-in wire is long enough to not restrict the turning movement, but short enough to not drag on the road. The trailer must have a lighting system and braking system to match and perform correctly off the towing vehicles system. You must meet the Federal and your States' Department of Transportation Code of Regulations concerning lights, brakes, and highway transit.
- 8) The break-away actuator (if equipped) that is installed on the trailer correctly works and is appropriately attached to the towing vehicle.
- 9) All lights and brakes on the trailer correctly functions when activated by the systems in the towing vehicle.
- 10) The tires have been checked for cuts or damaged rims, air pressure is correct, and the axle lug nuts have been checked for correct torque (refer to trailer manual).
- 11) When the stump grinder is on the trailer, the trailer has the right load capacity, the stump grinder is positioned on the trailer for the correct weight distribution (there should be about 15% of the total stump grinder package weight on the tongue or hitch), the stump grinder brakes are locked, the cutterwheel is resting on the trailer bed, and the stump grinder is securely bound down to the trailer bed per your States binding requirements.
- 12) Any loose debris, tools or parts have been cleared off or are put away.
- 13) Close and secure any of the following if equipped: tool box, battery box, engine cowl doors and side panels, radiator debris screens, inspection doors, cabinet doors, housing covers, tank caps and covers, vise, etc.
- 14) Make sure the load ramps are securely stored for transport.
- 15) Make sure the stump grinder's engine is not running, the ignition key is in your possession, and all controls are stored correctly and locked in place for transport.
- 16) The stump grinder package must be hauled level and the towing vehicle must be sized to handle hitch weight and towing weight. The towing vehicle or the combination of towing vehicle and towing package must have enough braking capacity to meet the Federal and your State Department of Transportation requirements.
- 17) The stump grinder package is now ready for transport. Make sure to obey all local regulation and laws regarding the transporting of this type of machine.
- 18) Do not drive too fast for road conditions or exceed speed regulations for equipment towing.

Loading & Unloading

WARNING

BEFORE LOADING OR UNLOADING THE MACHINE INSPECT AND CONFIRM THE FOLLOWING STEPS: When loading or unloading the self-propelled machine on the trailer, use care and caution. The maneuvering of the equipment must be slow, smooth, and intentional, not fast and jerky.

- 1) Make sure the trailer and towing vehicle are parked on a flat surface. They must be stable on the surface with the brakes locked and/or the wheels chocked to avoid unwanted movement.
- 2) Position the loading ramps or loading gate securely between the trailer and the ground level. Have them located so that they are in line with the tires or tracks of the machine when it moves.
- 3) Remove and store the chains and binders used for transporting.
- 4) Confirm that there are not any obstacles on the trailer bed, around the trailer that may cause restricted movement of the machine or the operator.
- 5) The only person in the area should be the one that is operating the machine controls, and he/she should be very experienced with the controls on this machine.
- 6) If you are on streets, roads or public areas, position the warning cones etc, per your company's safety policy.
- 7) Follow all pre-startup instructions for the machine.
- 8) Once the engine is running at as low a speed as possible, carefully raise the cutterwheel slightly up off the ground or trailer bed. While loading or unloading the stump grinder, the cutterwheel should not be raised any higher than necessary to just clear whatever is under it. You need to keep the weight center of gravity as low as possible to avoid tipping the machine while it is moving.
- 9) The cutterwheel end of the stump grinder should always be positioned so that it is toward the rear of the trailer, not the tongue, during transport.
- 10) When the machine is positioned on the trailer bed, there should be about 15% of the total trailer package weight on the tongue or hitch.
- 11) Align the machine with the trailer bed, and the loading ramps. The only equipment movement should be slowly, straight on or straight off the trailer.
- 12) With the engine and the machine at as low of speed as possible, move the machine toward the ramp system. Make sure the alignment is correct throughout the travel, and carefully readjust the cutter wheel height so that it barely clears obstacles as it is going up or down the ramp system.
- 13) Properly secure the equipment and the area to avoid any possible accidents or dangers.
- 14) The trailer should be constructed with appropriate chain down positions for the specific sized stump grinder. You must have binders that will withstand the strain of the machine trying to move while it is being transported.
- 15) The loading ramps or loading gate of the trailer must be constructed to withstand the weight and forces involved in loading and unloading the machine.

MAINTENANCE SECTION

The Bandit is a very simple machine to maintain. If you will follow a regular scheduled preventative maintenance program you should have years of trouble free operation.

⚠ DANGER

Before attempting any type of maintenance disengage clutch (if equipped), turn off engine, wait for the cutter head to come to a complete stop, place cutter head on the ground, switch the battery disconnect to the off position, and make sure the ignition key is in your possession.

⚠ DANGER

Do not let anyone operate or maintain this machine until they have thoroughly read this manual, reviewed the equipment decals, watched the equipment video, and has been properly trained. You can purchase additional Bandit manuals, decals and videos for a nominal fee.

NOTICE

Consult your engine manual for proper break-in procedures. Various engines require somewhat different procedures, but basically the engines need to operate at lower R.P.M.'s and loads for a specific time.

NOTICE

Failure to properly break-in your engine may result in poor bearing and piston ring surfaces.

NOTICE

The Bandit has only been run for a short time to test proper hydraulic pressures, possible leaks, etc. The fuel tank will be empty. Fuel is provided through a small auxiliary tank for testing. This immensely helps maintain safety in our manufacturing facility and while shipping.

NOTICE

Expensive damage to the Bandit will occur if proper preparation is not taken before welding on the machine. Be sure to disconnect both battery cables and the engine ECM (engine control module) before welding. Follow the specific Engine MFG. instructions for proper welding and grounding procedures, before attempting to weld on the machine. If welding on the machine, do not ground the welder through the machine bearings, ground near work to be performed.

DAILY START UP & MAINTENANCE

1) Check the safety decals and engine gauges:

Replace any missing or damaged decals and/or engine gauges.

2) Check all safety equipment:

Check for proper operation. Repair or replace as needed. Examples: deflection chains, cab window guard, etc.

3) Check entire machine for loose bolts, nuts, parts, or components:

Check entire machine for any loose parts or components. Check for loose nuts or bolts. Torque, tighten, or replace any of the loose components. See page 31 for specific bolt torques.

4) Check all guards:

Check to make sure all guards are in place and installed correctly. Make sure they are secure.

5) Check the cutter head or mower head & attachment:

Check for elongated bolt holes, secure welds, torqued bolts, excessive wear and impact cracks. If a problem is found contact the machine manufacturer or an authorized Bandit dealer.

6) Check condition of cutter teeth, tool holders, and attaching hardware:

Check condition of cutter teeth, tool holders, and attaching hardware. Look for, find, and tighten any component that has loosened up, become damaged, or is missing. Replace if necessary. Cutter teeth bolts must be replaced after a maximum of 4-5 rotations/changes to insure safe clamping ability.

Torque cutter teeth bolts to correct specs AT ALL TIMES.

Bandit

DAILY START UP & MAINTENANCE cont.**7) Grease mower head bearings (if equipped):**

Grease each mower head bearing with 1 shot for every hour of use with EP-2 Lithium type grease (example: if the machine was used for 8 hours, each bearing would require 8 pumps of grease). Wipe off excessive grease. **Excessive grease will attract dirt.**

8) Grease cylinder lug pin bushings:

Grease cylinder lug pin bushings with 1 to 2 shots of EP-2 Lithium type grease. Wipe off excessive grease. **Excessive grease will attract dirt.**

9) Check mower head belt tension (if equipped):

Remove the mower head guard and check the tension of mower head belt on each side of the head. Belt tension should measure 3/8" (9.5 mm) deflection with 70 to 80 lbs (32 to 36 kg) of force. New belt tension should be checked after 2 hours of operation, then every 4 hours for the first 48 hours of operation or until they quit stretching. Then belt tension should be checked daily.

10) Check hydraulic oil level:

Both hydraulic oil reservoir tank levels should always remain at 7/8 full. Remember to check DAILY to avoid excessive heat build up.

11) Check hydraulic shut-off valves:

Check to insure all shut-off valves are open.

12) Check for any fluid leaks:

Inspect for any oil, fuel, or hydraulic oil. Check all hoses, fittings, lines, and tanks. DO NOT use fingers or skin to check for hydraulic leaks. Repair or replace any damaged or leaking components.

13) Check the fuel level:

Check the fuel level, running out and repriming is time consuming. Do not over fill, and you must leave fuel expansion space in the top of the tank.

14) Check engine oil and coolant levels:

Follow the engine manufacturer manual recommendations for fluid levels. You MUST follow specific ENGINE MFG. manual recommendations for radiator coolant, additives, lubrication, correct engine speed, ETC.

15) Check radiator, debris screen:

Thoroughly clean radiator fins at least once a day and twice in excessive condition. Make sure debris is not packed between fins. Use pressurized water spray to clean. Do not rely on air pressure. The radiator will only appear to be clean. A partially plugged radiator will not allow the engine to cool properly. Clean cooling fan, shroud on air cooled engines, and the debris screen (if so equipped). Improper service, maintenance, or neglect will cause overheating problems and engine failure.

16) Check oil coolers:

Thoroughly clean cooler fins at least once a day and twice in excessive conditions. Make sure debris is not packed between fins. Use pressurized water spray to clean. Do not rely on air pressure. The oil coolers will only appear to be clean.

17) Check A/C condenser:

Thoroughly clean condenser fins at least once a day and twice in excessive conditions. Make sure debris is not packed between fins. Use pressurized water spray to clean. Do not rely on air pressure. The A/C condenser will only appear to be clean.

18) Check A/C filter:

Clean or replace foam A/C filter. Located inside of the cab behind the seat.

19) Check air cleaner or precleaner:

Clean or replace element following engine manual recommendations. Also, check and clean the vacuator valve.

20) Check gear box:

Check for proper lubrication and inspect the pump drives for leaks. Make sure the gear lube (85W/90 type gear lube) level is to the full mark on the dipstick, which is on the left hand side of the gear box. Too much oil in the gearbox may be an indication that an oil seal on a pump has failed and must be replaced. Bandit Industries, Inc. does not warranty gear box failures.

21) Check hydraulic control valves:

Inspect all hydraulic control valves and insure they operate smoothly and shift correctly.

continued on following page

Bandit

DAILY START UP & MAINTENANCE cont.

22) Inspect, adjust, and lubricate tracks:

Inspect, adjust, and lubricate tracks as needed per track MFG. manual.

23) Clean off mower attachment (if equipped):

Clean off the mower attachment daily. Remove any debris that builds up on top of the mower attachment, especially around the hydraulic hoses. This may need to be done more than once a day, depending on the application.

24) Check around machine:

Check around the entire machine for tools, cans, saws, etc. All tools not in use should be stored in a tool box.

25) Review all safety procedures on decals, from manual, and from video.

26) Make sure all safety equipment is being worn:

Make sure you are wearing all of your safety equipment: hard hat, face shield, gloves, eye protection, ear protection, etc. per ANSI and OSHA standards.

27) Turn battery disconnect switches on.

28) Make sure the throttle switch is in the idle position on the control panel.

29) Remember to check EVERYTHING on the checklist.

WEEKLY MAINTENANCE

1) Lubricate all steel friction areas:

Lubricate all steel friction areas including, but not limited to pivoting, hinged, sliding, rotating areas on the machine (i.e. doors, cab tilt hinge, winch rollers, etc.)

2) Grease stump grinder swing pivot bushings (if equipped):

Grease the top and bottom stump grinder swing pivot bushings with 1 to 2 shots of EP-2 Lithium type grease. Wipe off excess grease. **Excessive grease will attract dirt.**

3) Check and fill windshield washer reservoir:

Check and fill the windshield washer fluid reservoir. Located under the cab.

4) Check and retighten tank mount bolts:

Check the mount bolts for the fuel tanks and hydraulic tanks and retighten.

5) Remove mower head belt guards and clean out (if equipped):

Remove the mower head belt guards, wipe off any grease that has built up around the mower head bearings and remove any debris that has built up.

6) Check alternator and fan belts on engine (as applicable):

Adjust and maintain per the engine manufacturer's manual.

MONTHLY MAINTENANCE

1) Check hydraulic pressures:

Check, reset and maintain all hydraulic pressure settings to the specified maximum, see page 47. This will give you the best performance from the hydraulic system.

2) Check cab tilt pump reservoir:

Keep full of hydraulic oil, Petro-Canada Hydrex XV.

3) Check cab air filter:

Check and clean the air filter element on the back of the cab. Replace as needed.

3 MONTH MAINTENANCE

1) Hydraulic oil filter (In-Tank):

Must be replaced after FIRST 10 HOURS OF OPERATION, USE A 10 MICRON FILTER. After first change replace oil filter every 3 months or 400 hours.

2) Charge filters:

Must be replaced after FIRST 10 HOURS OF OPERATION, USE A 10 MICRON FILTER. After first change replace oil filters every 3 months or 400 hours. Total of 4, located on the pumps behind the operator's cab..

6 MONTH MAINTENANCE

1) Hydraulic pump gear box:

Change gear lube after first 100 hours, then every 6 months or every 2000 hours afterwards. Requires approximately 10 quarts (9.46 L) of 85W/90 type gear lube, use the sight window to fill to the proper level. Do not overfill, too much oil will overheat the gear box.

2) Windshield Wiper:

Check the windshield wiper. Replace as needed.

YEARLY MAINTENANCE

1) Grease mower overhung load adapters (if equipped):

Grease both zerks on each overhung load adapter that the cutter head hydraulic motors plug into with 1 to 2 shots of EP-2 Lithium type grease. Wipe off excessive grease. **Excessive grease will attract dirt.**

2) Hydraulic oil:

Change hydraulic oil and flush the hydraulic reservoir tanks.

3) Hydraulic suction screens:

Change hydraulic suction screens yearly or every 2000 hours.

4) Cab tilt pump reservoir:

Change hydraulic oil and flush the cab tilt pump reservoir.

DAILY START UP & MAINTENANCE CHECK LIST

Each day before starting your machine these checks must be made:

	O.K.	Repaired
1) Check the safety decals and engine gauges, replace if damaged.	<input type="checkbox"/>	<input type="checkbox"/>
2) Check, maintain, and service all safety equipment for proper operation: deflection chains, cab window guard, cab cylinder locks, etc.	<input type="checkbox"/>	<input type="checkbox"/>
3) Check entire machine for loose nuts, bolts, and components.	<input type="checkbox"/>	<input type="checkbox"/>
4) Check all guards to make sure they are tight and securely in place.	<input type="checkbox"/>	<input type="checkbox"/>
5) Check the condition of the cutter head and mower attachment.	<input type="checkbox"/>	<input type="checkbox"/>
6) Check the condition of the cutter teeth, tool holder, and hardware.	<input type="checkbox"/>	<input type="checkbox"/>
7) Grease mower head bearings with 1 shot for every hour of use.	<input type="checkbox"/>	<input type="checkbox"/>
8) Grease cylinder lug pin bushings with 1 to 2 shots.	<input type="checkbox"/>	<input type="checkbox"/>
9) Check and adjust mower head belt tension, both sides (70-80 lbs with 3/8" deflection).	<input type="checkbox"/>	<input type="checkbox"/>
10) Check and always maintain hydraulic oil level at 7/8 full.	<input type="checkbox"/>	<input type="checkbox"/>
11) Check to insure all hydraulic shut-off valves are open.	<input type="checkbox"/>	<input type="checkbox"/>
12) Check all hoses, fittings, lines, and tanks for damage and fluid leaks.	<input type="checkbox"/>	<input type="checkbox"/>
13) Check fuel level. (Running out and repriming is time consuming).	<input type="checkbox"/>	<input type="checkbox"/>
14) Check engine oil, coolant levels, and correct engine speed. Follow ENGINE MANUFACTURER'S manual specs. Engine Must Be Level To Check Fluids.	<input type="checkbox"/>	<input type="checkbox"/>
15) Check radiator and debris screen. Clean as necessary. Clean cooling fan and shroud on air cooled engines.	<input type="checkbox"/>	<input type="checkbox"/>
16) Check oil coolers. Clean as necessary.	<input type="checkbox"/>	<input type="checkbox"/>
17) Check A/C condenser. Clean as necessary.	<input type="checkbox"/>	<input type="checkbox"/>
18) Check A/C filter (located behind the seat). Clean as necessary.	<input type="checkbox"/>	<input type="checkbox"/>
19) Check air cleaner, precleaner, and vacuator valve. Clean as necessary.	<input type="checkbox"/>	<input type="checkbox"/>
20) Check gear box for proper lubrication and inspect the pump drive for leaks. Keep full of 85W/90 type gear lube.	<input type="checkbox"/>	<input type="checkbox"/>
21) Check hydraulic control valves and insure they operate and shift correctly.	<input type="checkbox"/>	<input type="checkbox"/>
22) Inspect, adjust, lubricate tracks per manufacturer's manual recommendations.	<input type="checkbox"/>	<input type="checkbox"/>
23) Clean & remove any debris that builds up on top of the mower head, if equipped.	<input type="checkbox"/>	<input type="checkbox"/>
24) Check around the entire machine for any foreign objects, tools, cans, saws, etc.	<input type="checkbox"/>	<input type="checkbox"/>
25) Review all safety procedures on decals, from manual, and from video.	<input type="checkbox"/>	<input type="checkbox"/>
26) Wear all applicable safety equipment: hard hat, face shield, gloves, eye protection, ear protection, etc.	<input type="checkbox"/>	<input type="checkbox"/>
27) Turn battery disconnect switches on.	<input type="checkbox"/>	<input type="checkbox"/>
28) Make sure the throttle switch is in the idle position on the control panel.	<input type="checkbox"/>	<input type="checkbox"/>
29) Remember to check EVERYTHING on the checklist.	<input type="checkbox"/>	<input type="checkbox"/>

WEEKLY CHECK LIST

- | | O.K. | Repaired |
|--|--------------------------|--------------------------|
| 1) Lubricate steel friction areas: pivoting, hinged, sliding, & rotating areas (i.e. doors, cab tilt hinge, winch rollers, etc). | <input type="checkbox"/> | <input type="checkbox"/> |
| 2) Grease top & bottom stump grinder swing pivot bushings with 1 to 2 shots, if equipped. | <input type="checkbox"/> | <input type="checkbox"/> |
| 3) Check and fill the windshield washer fluid reservoir. Located under the cab. | <input type="checkbox"/> | <input type="checkbox"/> |
| 4) Check and retighten mount bolts for fuel tanks and hydraulic tanks. | <input type="checkbox"/> | <input type="checkbox"/> |
| 5) Remove mower head belt guards, wipe off grease, and clean out debris, if equipped. | <input type="checkbox"/> | <input type="checkbox"/> |
| 6) Check alternator and fan belts on engine. | <input type="checkbox"/> | <input type="checkbox"/> |

MONTHLY CHECK LIST

- | | O.K. | Repaired |
|--|--------------------------|--------------------------|
| 1) Check hydraulic pressure. Set to specified PSI (bar). | <input type="checkbox"/> | <input type="checkbox"/> |
| 2) Check cab tilt pump reservoir, keep full of hydraulic oil. | <input type="checkbox"/> | <input type="checkbox"/> |
| 3) Check and clean cab air filter on back of cab. Replace as needed. | <input type="checkbox"/> | <input type="checkbox"/> |

3 MONTH CHECK LIST

- | | O.K. | Repaired |
|--|--------------------------|--------------------------|
| 1) Replace hydraulic oil filter after first 10 hours, then quarterly or every 400 hours. | <input type="checkbox"/> | <input type="checkbox"/> |
| 2) Replace charge filters (4 total) after first 10 hours, then quarterly or every 400 hours. | <input type="checkbox"/> | <input type="checkbox"/> |

6 MONTH CHECK LIST

- | | O.K. | Repaired |
|---|--------------------------|--------------------------|
| 1) Change gear lube (85W/90 type gear lube) in hydraulic pump gear box after first 100 hours, then every 6 months or every 2000 hours afterwards. | <input type="checkbox"/> | <input type="checkbox"/> |
| 2) Check the windshield wiper. Replace as needed. | <input type="checkbox"/> | <input type="checkbox"/> |

YEARLY CHECK LIST

- | | O.K. | Repaired |
|--|--------------------------|--------------------------|
| 1) Grease mower overhung load adapters with 1 to 2 shots (4 zerks total), if equipped. | <input type="checkbox"/> | <input type="checkbox"/> |
| 2) Change hydraulic oil and flush the hydraulic tanks. | <input type="checkbox"/> | <input type="checkbox"/> |
| 3) Replace the hydraulic suction screens annually or every 2000 hours. | <input type="checkbox"/> | <input type="checkbox"/> |
| 4) Change hydraulic oil and flush the cab tilt pump reservoir. | <input type="checkbox"/> | <input type="checkbox"/> |

BOLT TORQUE CHART

(THESE TORQUES ARE BASED ON DRY, CLEAN THREADS)

DESCRIPTION	BOLT SIZE	TORQUE (FT.-LBS.)	TORQUE (Nm)
Mower Head Tooth Bolt	3/4"-10 NC	376	509
Mower Head Bearing Bolts	3/4"-10 NC	225	305
Mower Head Bearing Set Screws		39	53
Mower Head Sheave Bushing "3535"		83	113
Mower Head Shaft Bushing		61	82
Mower Head Motor Sheave Bushing "3535"		83	113
Cutter Wheel To Hydrostatic Motor Bolts	M20 - 2.5	184 - 202	250 - 274
Hydrostatic Motor To Upper Frame Bolts	3/4"-10 NC	340	461
Cutter Wheel Teeth Bolts	7/8"-14 NF	600	813
Engine Hold Downs	3/4"-10 NC	350	475
Valve Solenoid Retainer Nut		4 - 6	5 - 8

Before tightening bolts be sure you have the correct size bolt for the correct amount of torque.
Use only factory approved bolts and hardware.

PAINT CARE

To help keep up the appearance of your Bandit Equipment and reduce the possibility of surface rust follow these steps:

- 1) The machine should be washed on a regular basis with a non-abrasive mild detergent and then rinsed thoroughly. Do not pressure wash sensitive areas like: decals, gauges, electronic devices, autofeed control, etc.
- 2) If a stone chip, paint scratch, or paint crack occurs - it should be repaired immediately. Simply sand the edges of the damaged paint area, mask off the surrounding area and apply primer and paint to the dry, clean, and warm surface. This will help keep the damaged area from spreading or getting worse.
- 3) If you are unable to sand and mask the area, there are containers of primer and paint available. A small brush can be used to touch up the area.
- 4) Also, primer and most colors of paint are available in aerosol spray cans to simply spray over the effected area after it is cleaned, dry, and warmed. This method is not as reliable as the process in step #2.

It is also reported that some equipment owners polish their machine at least yearly, and keep good mud flaps on their towing trucks.

MAINTENANCE SECTION



Clean or replace foam A/C filter. Located inside of the cab behind the seat.

WINDOW WASHING INSTRUCTIONS:

DO NOT use any glass cleaner on windows. Follow these steps to clean the windows:

- 1) Rinse with water to remove abrasive dust and dirt
- 2) Wash with soap or mild detergent, using a soft cloth or sponge
DO NOT SCRUB
- 3) Rinse once more, then dry with a soft cloth or chamois
- 4) To remove grease, wet paint or stickers. Rub gently with a cloth wetted thoroughly in VM&P Naptha or Isopropyl Alcohol. Wash and rinse.

DO NOT USE RAZOR BLADES, SCRAPPERS, SQUEEGEES, ETC.

Also use these instructions on the back-up camera cover.

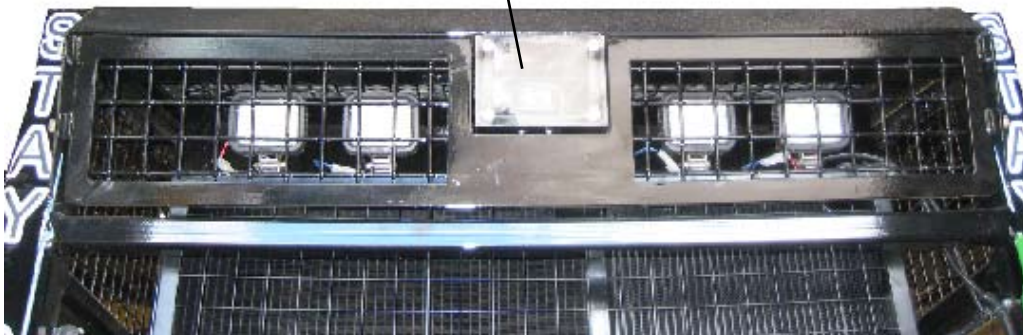

LUBRICATION CHART

#	DESCRIPTION	CHECK			PROCEDURE
		DAY	WEEK	MONTH	
1	Cutter Head Bearings	X			1 shot of grease per hour of use - wipe off excess
2	Cylinder Lug Pin Bushings	X			1 to 2 shots of grease - wipe off excess
3	Steel Friction Areas: pivoting, hinged, sliding, rolling		X		Lubricate (i.e. doors, cab tilt hinge, winch rollers, etc)
4	Swing Pivot Bushings		X		1 to 2 shots of grease - wipe off excess
5	Overhung Load Adapter			Yearly	1 to 2 shots of grease per zerk - wipe off excess
6	Tracks	—————▶			Grease per MFG's instructions



NOTICE Use as a reference only, locations may vary depending on options or component manufacturer. Lubrication point instructions are described on the machine, in the Lubrication & Coolant Section and Maintenance Section of this manual, or component manufacturer's manual.

Bandit

LUBRICATION CHART

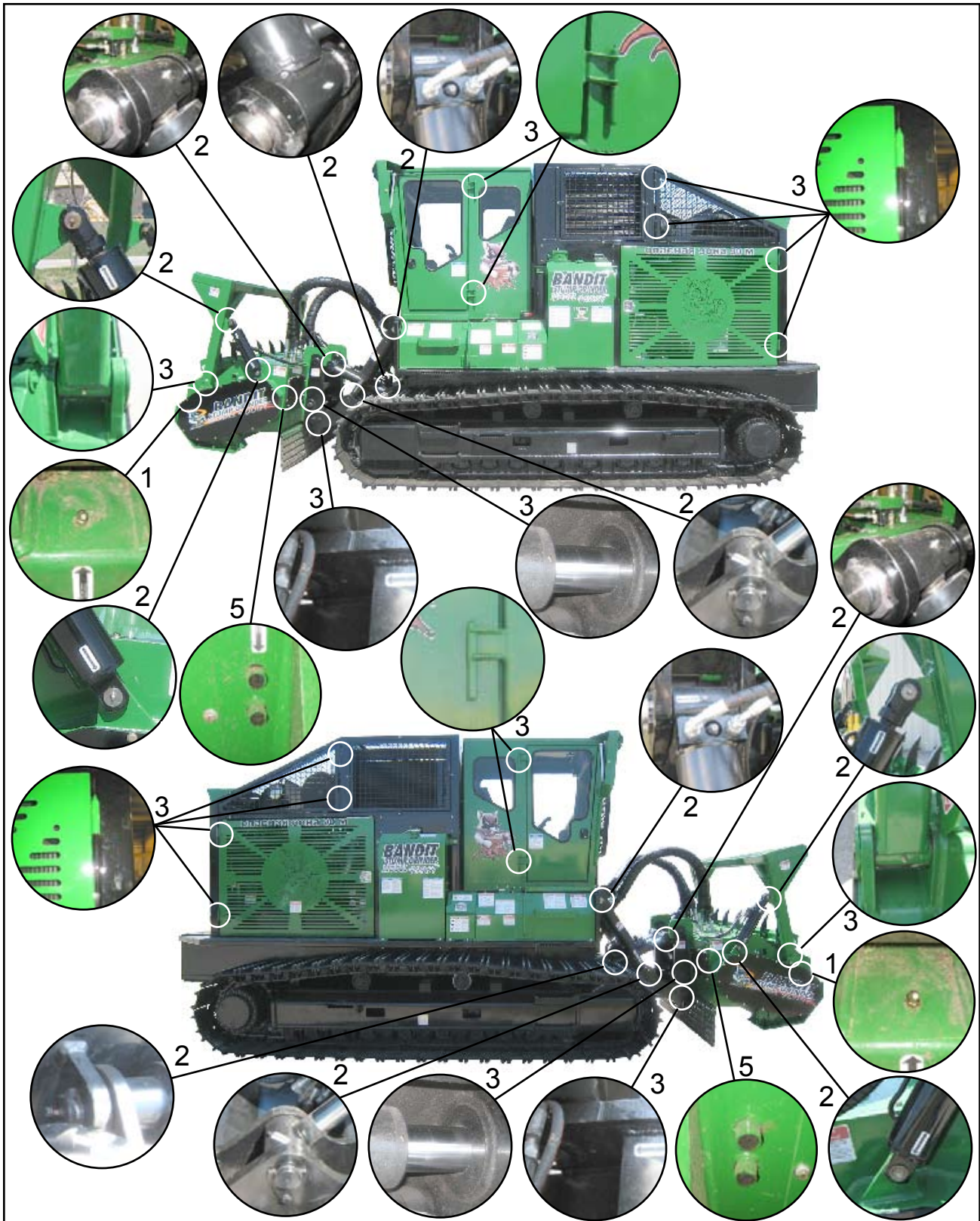

NOTICE Use as a reference only, locations may vary depending on options or component manufacturer. Lubrication point instructions are described on the machine, in the Lubrication & Coolant Section and Maintenance Section of this manual, or component manufacturer's manual.

Bandit

BELT TENSION

GENERAL RULES FOR TENSIONING

1. Check tensioning during the first 2 through 48 hours of run-in operation especially.
2. Over tensioning or under tensioning shortens belt and bearing life.
3. Keep belts free from foreign materials that may cause the belt to slip.
4. Make belt inspections on a periodic basis. Never use belt dressing as this will damage the belt and cause early failure.
5. Belts should never be forced over the sheave. Allow enough room for belts to slip on.
6. Always make sure sheaves are aligned properly.

NOTICE It is a good practice to rotate the belts during tensioning. Then recheck deflections. The belts may need to be tightened again.

DO NOT IGNORE THIS MAINTENANCE RULE!

New belts stretch very soon and must be adjusted several times in the first few hours of operation. Adjust after one hour of operation, then every four hours until the belts quit stretching.

Failure to do this will cause the belts to burn and fly off. **THIS FAILURE IS NOT COVERED BY WARRANTY!**

CUTTER HEAD BELTS (Poly Chain Belts)

Special care needs to be taken with your cutter head belt. Alignment, tension, and cleanliness of this belt is very important. The cutter head belt needs to be checked for tension approximately every 10 to 20 hours of use. The cutter head belt must be running true. If the belt runs on an angle, it will cause belt failure. When replacing the cutter head belts, do not try to pry the belt on over pulley, this can break the fibers in the cutter head belt.

1. Follow all pre-maintenance shut down procedures.
2. Remove the cutter head belt guard.
3. Remove the old belt and replace with a new one, if replacing.
4. Measure the belt tension, proper belt tension is 3/8" (9.5 mm) deflection with 70 to 80 lbs (32 to 36 kg) of force.
5. To adjust tension of the belt, loosen the 4 bolts on cutter head bearing mount.
6. Tighten or loosen the belt tension adjuster.
7. Check the belt tension with a sonic tension meter and readjust if necessary.
8. Tighten the cutter head bearing mount bolts.
9. Tighten the jam nuts on the belt tension adjuster.
10. Check the belt to make sure it is at the specified tension.
11. Check cutter head sprockets, with a straight edge to ensure that they are in line.
12. Replace the cutter head belt guard.
13. Repeat procedure to the belt on other side of the cutter head.

NOTICE

Cutter Head Belt Tension: 3/8" (9.5 mm) deflection with 70 to 80 lbs (32 to 36 kg) of force.

CUTTER HEAD BELTS (Poly Chain Belts) cont.

Poly Chain Sprocket Alignment and Installation

Sprocket alignment is very important. Proper alignment allows the load to be transformed equally across the belt width, which reduces wear and improves belt life.

1. Place a straight edge on the outside of the drive sprocket, making sure that the straight edge touches the outside and inside of the sprocket.
2. Move the sprocket until the straight edge touches both outside edges and inside edges.
3. Make sure the sprockets are properly aligned. Alignment should be within 1/4 degree. This is the maximum "M" dimension of .05" per foot (1.3 mm per 305 mm) center distance.

ANGULAR MISALIGNMENT

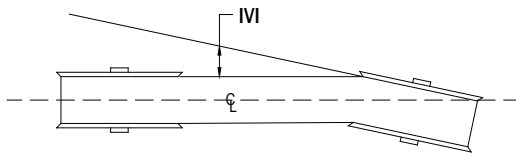

PARALLEL MISALIGNMENT

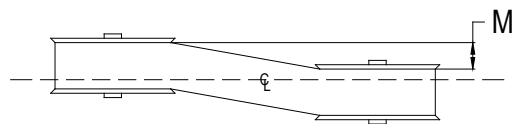

Sprocket Installation

1. Inspect the bore of the sprocket and the bushings tapered surface. Remove any oil, dirt or grease.
2. Place bushing in the sprocket inserting screw loosely.
3. Place key in key set and slide sprocket to its desired location with the screw head facing outside. If bushing goes on hard check shaft for burrs, remove if necessary.
4. Check for proper alignment of belts and evenly tighten bolts to recommended torque (SEE PAGE ??).

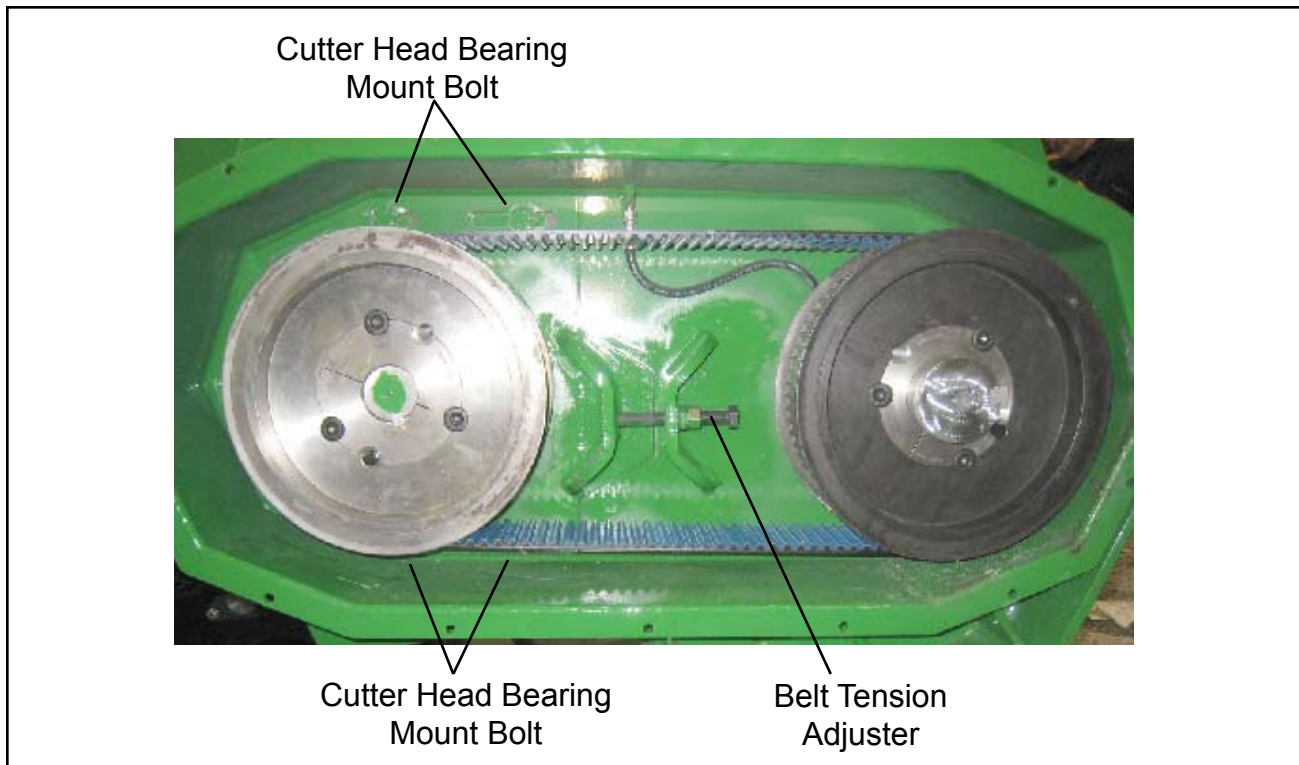

CAB TILTING INSTRUCTIONS

⚠ DANGER

Before attempting any type of maintenance disengage clutch (if equipped), turn off engine, wait for the cutter head to come to a complete stop, turn the battery disconnect to the off position, and make sure the ignition key is in your possession.



⚠ DANGER

AVOID EQUIPMENT AND PERSONAL INJURY WHEN TILTING THE CAB.



DO NOT ALLOW ANYONE IN THE CAB WHEN IT IS TILTING OPEN OR CLOSED.

DO NOT ALLOW ANYONE NEAR THE CAB WHEN IT IS TILTING OPEN OR CLOSED.

DO NOT TILT THE CAB WITH THE CAB DOORS OPEN. SECURE IN CLOSED POSITION.

BE AWARE AND AVOID ALL PINCH POINTS OF THE CAB WHEN OPENING OR CLOSING.

ALWAYS OPERATE THE CAB TILT SLOWLY AND CAREFULLY.

ALWAYS SECURELY BOLT THE CAB IN THE "DOWN" POSITION DURING OPERATION OR TRANSPORT.

ALWAYS USE THE CAB CYLINDER LOCKS WHEN THE CAB IS TILTED.

- 1) Read all instructions and Dangers before starting procedures.
- 2) Make sure the cutter head is resting on the ground.
- 3) Follow all pre-maintenance shut down procedures.
- 4) Switch the 12 volt power disconnect switch to the on position. See Figure 1.
- 5) Unbolt the cab lock. See Figure 2.
- 6) Push the lever away from the operator to lift the cab. See Figure 3.
- 7) Switch the 12 volt power disconnect switch to the off position. See Figure 1.
- 8) Pin the cylinder locks in place before doing anything under the cab. See Figure 4.
- 9) To lower the cab reverse the steps.

Figure 1



12 volt circuit disconnect switch
(Turn to the off position after tilting the cab and before performing maintenance)

24 volt circuit disconnect switch

CAB TILTING INSTRUCTIONS cont.

Figure 2



The cab lock bolt is located on each side of the cab about half way up. Remove the bolt.

Figure 3



Push the lever away from the operator to lift the cab. Pull the lever towards the operator to lower the cab. Make sure the 12 volt power disconnect switch is in the on position and the cab lock pin is unlocked.

Figure 4



⚠ DANGER

Before attempting any type of maintenance or service work under the cab make sure the cylinder locks are in place.

Cylinder Locks in place on the cab tilt cylinders

GEAR BOX

DANGER

Before attempting any type of maintenance disengage clutch (if equipped), turn off engine, wait for the cutter head to come to a complete stop, turn the battery disconnect to the off position, and make sure the ignition key is in your possession.

CHECK OIL LEVEL

IMPORTANT: Check oil level at the beginning of each day the machine is used. Inspect the gear box for leaks or visible damage.

- 1) Run the gear box until the lubricating oil is warm.
- 2) Be sure the gear box is level and the machine is on level ground.
- 3) Lower all equipment to the ground.
- 4) Stop engine before servicing gear box and follow all pre-maintenance shut down procedures.
- 5) Block the machine so that it can not move.
- 6) Clean around the dipstick gauge.
- 7) Keep the oil level at the full mark on the dipstick.

IMPORTANT: Too much oil in the gear box may be an indication that an oil seal on a pump has failed and must be replaced.

- 8) Check oil level.

IMPORTANT: The oil should be changed anytime it shows traces of dirt, contamination by other fluids or the effects of high temperature evidenced by discoloration or strong odor.

Under no circumstances should the gear box oil go unchanged for more than 6 months. Condensation may contaminate the oil reducing its effectiveness.

- 9) Add oil or change oil if necessary.

IMPORTANT: Do not overfill. Too much oil will cause the gear box to overheat.

OIL CHANGE PROCEDURE

Change oil after the first 100 hours of service or 6 months, whichever comes first. Then, change oil every 2000 hours of service or 6 months whichever comes first.

- 1) Run the gear box until the lubricating oil is warm.
- 2) Be sure the gear box is level and the machine is on level ground.
- 3) Lower all equipment to the ground.
- 4) Stop engine before servicing gear box and follow all pre-maintenance shut down procedures.
- 5) Block the machine so that it can not move.
- 6) Clean around the oil drain, fill, and check locations.
- 7) Look for oil leaks and damage.
- 8) Place a container that is large enough to hold all of the oil in the gear box under the drain location (approximately 10 quarts or 9.46 L).
- 9) Remove drain plug.
- 10) Look for metal particles on the magnetic end of drain plug.
- 11) Clean and replace drain plug.
- 12) Remove the fill plug and breather as an assembly.
- 13) Clean, inspect, and check the breather for function.

NOTE: The breather should allow pressure to vent inside the gear case as it heats and cools while keeping out dirt and water.

IMPORTANT: Do not overfill. Too much oil will cause the gear box to overheat.

- 14) Refill the gear case to proper level using 85W/90 type gear lube (approximately 10 quarts or 9.46 L).
- 15) Replace the fill plug and breather assembly.
- 16) Operate the gear box for several minutes. Look for oil leaks and listen for unusual sounds.

Bandit

GEAR BOX

View looking in through the road (left) side engine panel door.



Gear Box fluid level dipstick.



View looking behind the operator's cab.



Gear Box breather and fill cap.

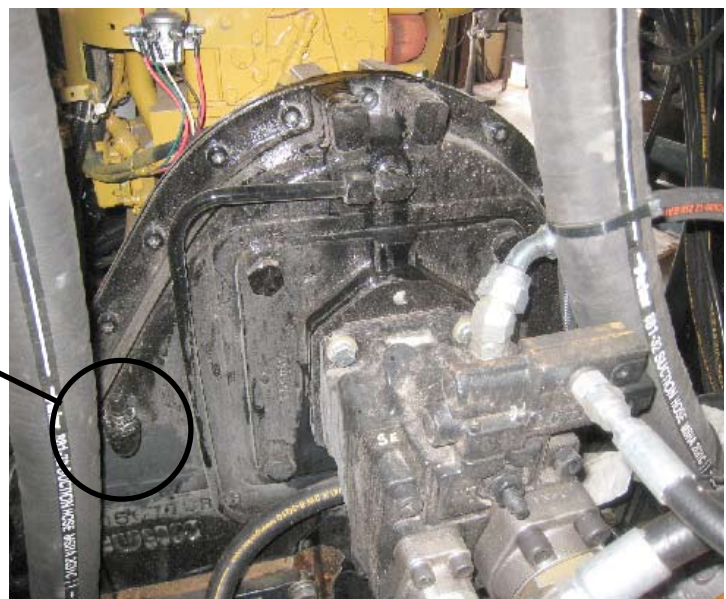

MAINTENANCE SECTION



The window washer fluid tank is located under the cab on the back side of the left hand side fuel tank. Keep full.



⚠ DANGER

Before attempting any type of maintenance or service work under the cab make sure the cylinder locks are in place.

Cylinder Locks in place on the cab tilt cylinders



Cab air filter located on the back side of the cab. The cab will need to be tilted to access. Check and clean the air filter element on the back of the cab monthly. Replace as needed.

HYDRAULIC SECTION

⚠ WARNING

DO NOT GO NEAR HYDRAULIC LEAKS!

High pressure oil easily punctures skin causing serious injury, gangrene, or death. If injured, seek emergency medical help. Immediate surgery is required to remove oil. DO NOT use fingers or skin to check for leaks. Lower load or relieve hydraulic pressure before loosening fittings.

⚠ WARNING

DO NOT operate this machine unless all hydraulic control devices operate properly. They must function, shift and position smoothly and accurately at all times. Faulty controls can cause personal injury!

HYDRAULIC FLUID REQUIREMENTS

This machine is equipped with “Petro-Canada Hydrex XV” hydraulic fluid. It is recommended to replace with the same. “Petro-Canada Hydrex XV” is an all season hydraulic fluid. This is a premium performance, long life anti-wear, hydraulic fluid, designed for all season use in heavy duty hydraulic systems. “Petro-Canada Hydrex XV” allows year round use under wide extremes of temperature. It allows the hydraulic system to start at temperatures as low as -40°C/-40°F, under no load conditions and it improves lubrication of hydraulic components at high operating temperatures. It will also help protect against hydraulic failures during the wide temperature swings of spring and fall. To find the closest “Petro-Canada Hydrex XV” dealer call 1-888-284-4572.

Multi Viscosity motor oils are not recommended to mix with “Petro-Canada Hydrex XV” hydraulic oil. AW oils may mix with “Petro-Canada Hydrex XV” hydraulic oil. The following are specifications and authorizations of compatible oils. Only a high quality anti-wear (AW) hydraulic oil containing foam, corrosion, rust and oxidation inhibitors should be used. This viscosity grade depends on the oil temperature in service, based on the climate and operating conditions.

	Hydrex XV	ISO 22, AW	ISO 32, AW	ISO 46, AW	ISO 68, AW	ISO 100, AW
Viscosity Index	>235	>95	>95	>95	>95	>95
Flash Point	>240°C /464°F	>200°C /395°F	>210°C /410°F	>220°C /430°F	>220°C /430°F	>240°C /464°F
Oxidations Stability (ASTM D0943)	>9,000 Hours	>3,000 Hours	>3,000 Hours	>3,000 Hours	>3,000 Hours	>3,000 Hours
Cold Start-up, No Load, Max	-40°C/-40°F	-34°C/-29°F	-26°C/-14°F	-19°C/-3°F	-9°C/16°F	-4°C/24°F

HYDRAULIC SECTION

Alternate hydraulic oils are available, but they do not equal the performance or longevity of the "Hydrex XV" oil. Consult the following information supplied by the oil distributor.

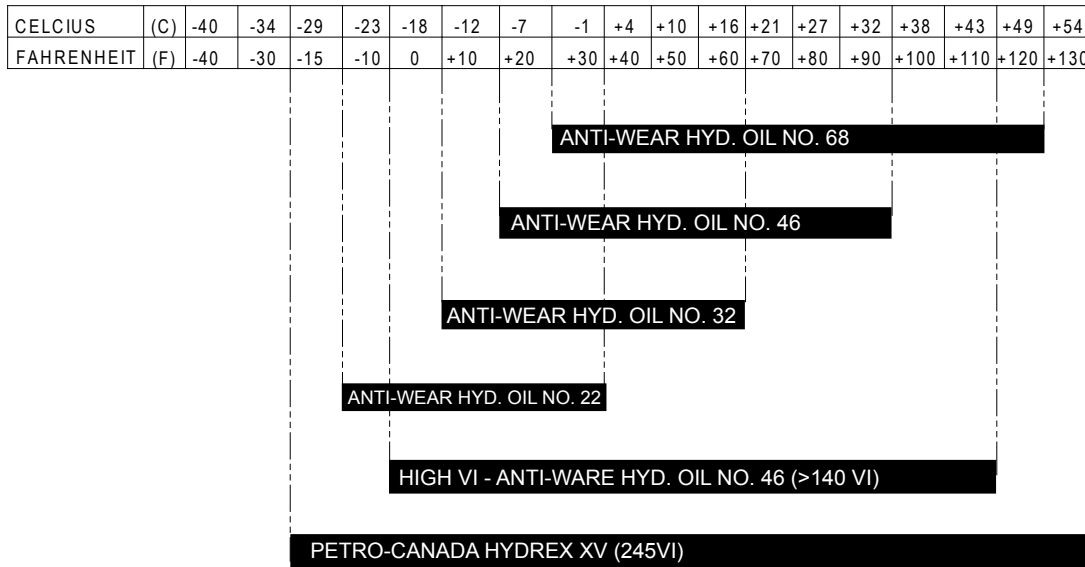

Note: The above chart is a suggested guide for viscosity of hydraulic fluids at start up ambient temperature. The load, demand, and cleanliness of the equipment will affect actual oil temperatures which can increase dramatically above ambient air temperatures during operation. The actual viscosity needed is based on oil temperature during operation and not air temperature. Compare your fluid specifications with the specifications below to verify compliance.

When choosing a hydraulic fluid - these maximum and minimum specifications must be met:

Minimum Viscosity during operation = 12 cSt
 Maximum No-Load Viscosity at start-up = 2000 cSt

Hydraulic fluids vary in their resistance to oxidation at elevated temperatures, their ability to protect against metal-to-metal contact under increasing temperature, and their ability to separate water from the fluid. Viscosity is temperature dependant. Fluids with high viscosity-index (VI) will thin out slower at higher temperature and thicken slower at colder temperatures allowing a wider operating range. Choose a fluid that has test results in these areas for best results.

Based on the varying temperatures of the area where Bandit equipment is used, and the high demand and loads placed on this equipment, Bandit has filled each hydraulic system with Petro-Canada's Hydrex XV All Season Hydraulic Fluid for maximum protection and performance.

Contact Petro Canada at (888) 284-4572 to find a dealer near you.

NOTICE

Some equipment and components such as fluid engagement clutch's (PTO's) have their own lubrication requirements. Consult their manufactures manual for that information.

HYDRAULIC SECTION

THE BANDIT HYDRAULIC SYSTEM

The Bandit is equipped with a very efficient, simple hydraulic system. Each component is capable of withstanding a specified PSI (bar) and still operate for a very long time.

If the simple rules mentioned below are followed, the hydraulic components will last for years:

- After you have operated a new machine for approximately an hour shut down the machine and recheck all hydraulic fittings for tightness and leaks.
- Avoid hydraulic pump cavitation. Low oil levels or cold start-ups will cause the hydraulic pump to cavitate. Cavitation will ruin the pump and possibly the entire hydraulic system. Cavitation only has to happen once. This will start the pump on its way to ruin. Allow hydraulic system to turn slowly for several minutes in cold weather in order for hydraulic system to warm up. Cavitation is not covered under warranty.
- Do not increase the relief valve settings beyond specified PSI (bar). This will cause damage to hydraulic components. Do not set any other hydraulic component past it's specified pressure or this will cause damage to the hydraulic components.
- Keep hydraulic oil clean. Dirty oil will cause excessive wear and loss of hydraulic power.
- Replace the hydraulic oil filter(s) after first 10 hours and with each 400 hours of operation or 3 months.
- Replace hydraulic oil & suction screen(s) at least once yearly. This is also a very good time to flush and clean the tank. Replace hydraulic oil immediately if it is contaminated or looks "milky". See pages 43 - 44 for hydraulic oil requirements.
- If the Bandit's hydraulic system is kept clean and the hydraulic pressures are not increased beyond the specified PSI (bar), the maximum use and life should be received from the Bandit grinder hydraulic system.
- If a problem is encountered, it will more than likely be located in the relief valve or something as simple as belts slipping, check these first.
- Do not close the hydraulic shut-off valve for more than 3 to 4 seconds. Hydraulic shut-off valve handle must be completely turned on at all times unless checking hydraulic pressure. Pressure gauge should be safely stored and installed only when checking pressure. Follow above instructions or this will cause unwarranted damage to the hydraulic components.
- Never close the ball valves on the hydraulic tank suction ports (if equipped) while the machine is running, this will ruin the hydraulic pump and components. Close the ball valves for service purposes only.
- Some component manufacturers require different specific hydraulic lubrication, such as gear boxes, undercarriage drives, etc. Refer to their manuals and maintenance section of this manual.

WARNING

It is very important after you have operated a new machine for approximately an hour to shut down the machine and recheck all hydraulic fittings. Retighten as needed.

DO NOT GO NEAR HYDRAULIC LEAKS! High pressure oil easily punctures skin causing serious injury, gangrene, or death. Avoid burns from fluid. Hot fluid under pressure can cause severe burns. **DO NOT** use fingers or skin to check for leaks. Lower load or relieve hydraulic pressure before loosening fittings. Relieve all pressure in the system before disconnecting the lines, hoses, or performing other work. Use a piece of cardboard to find leaks. Never use your bare hands. Allow system to cool down to ambient temperature before opening any coolant or hydraulic oil system.

In cold weather situations let your hydraulic system idle for approximately 15 minutes to allow the system to warm up to operating temperature.

WARNING

DO NOT operate this machine unless all hydraulic control devices operate properly. They must function, shift and position smoothly and accurately at all times. Faulty controls can cause personal injury!

NOTICE

All components and parts being returned to Bandit Industries for warranty consideration must be complete and assembled when delivered. Hydraulic components and parts must be returned assembled with all fluid ports capped or plugged and free of foreign contamination, or warranty will not be considered.

Bandit

HYDRAULIC SECTION

⚠ DANGER

Before attempting any type of maintenance disengage clutch (if equipped), turn off engine, wait for the cutter head to come to a complete stop, place cutter head on the ground, switch the battery disconnect to the off position, and make sure the ignition key is in your possession.

NOTICE

DO NOT UNDER ANY CIRCUMSTANCES OVER-SET THESE RELIEF PRESSURES, BECAUSE IT WILL CAUSE DAMAGE TO COMPONENT PARTS AS WELL AS HYDRAULIC PARTS.

NOTICE

These Typical Hydraulic Flows And Relief Pressure Settings Are With The Engine At Full RPM. All Settings Are Subject To Change!

⚠ CAUTION

After the initial start-up of the machine and after any replacement of hydraulic components, that fittings and hoses should be re-checked for leaks and clearances.



⚠ DANGER

Before attempting any type of maintenance or service work under the cab make sure the cylinder locks are in place.

Cylinder Locks in place on the cab tilt cylinders

HYDRAULIC SECTION



HYDRAULIC RELIEF VALVE SETTING

Equipment Model	4000T / 5000T
Cutter Head Pressure	6500 PSI (448 bar)
Cutter Head Charge Pressure	480 PSI (33 bar)
Track Pressure	4900 PSI (337 bar)
Track Charge Pressure	420 PSI (29 bar)
Auxiliary Valve Main Relief Pressure	2900 PSI (200 bar)
Head Up / Down Pressure	2800 PSI (193 bar)
Head Tilt Pressure	2800 PSI (193 bar)
Attachment Lock Pin Pressure	2500 PSI (172 bar)
Mower Rake / Gate Pressure	2000 PSI (137 bar)
Mower Push Bar Pressure	1800 PSI (124 bar)
Winch Pressure	2500 PSI (172 bar)
Cab Tilt Pressure	2200 PSI (151 bar)
Left & Right Oil Cooler Fan Pressure	1600 PSI (110 bar)
Reversing Fan Pressure	600 PSI (41 bar)
Accumulator Pressure	minimum 240 PSI (17 bar)

AUXILIARY VALVE (located underneath cab)

Valve Section
Relief



Valve Section
Relief

NOTICE

The handles on the valve sections are for manual override during trouble shooting.

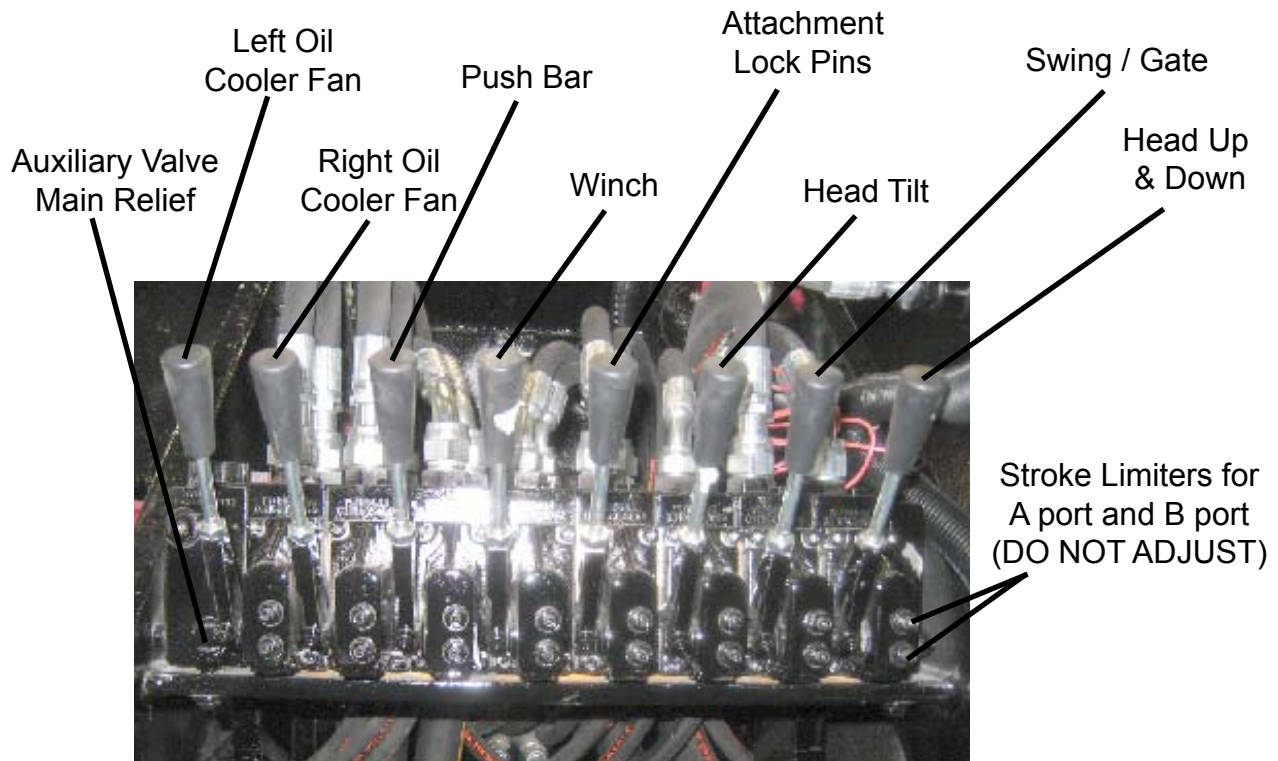

PUMPS

Left Side of Machine

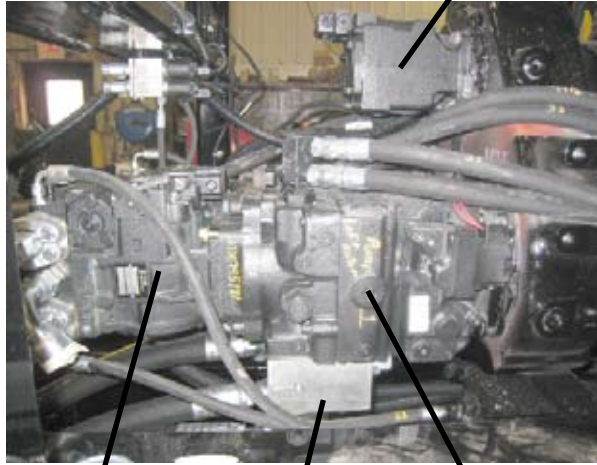

Left Track Pump

Cutter Head Pump A & B Port Blocks (1 Per Port) with 5 PSI (.3 bar) Anticavitate Check Valve

Left Cutter Head Pump

Auxiliary Pump

Right Side of Machine

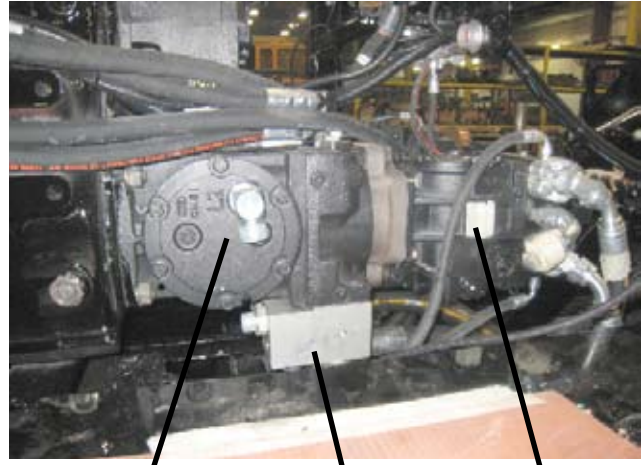

Right Cutter Head Pump

Cutter Head Pump A & B Port Blocks (1 Per Port) with 5 PSI (.3 bar) Anticavitate Check Valve

Right Track Pump

CHARGE FILTERS

(located behind cab)

Right Cutter Head Charge Filter

Left Cutter Head Charge Filter

Right Track Charge Filter

Left Track Charge Filter

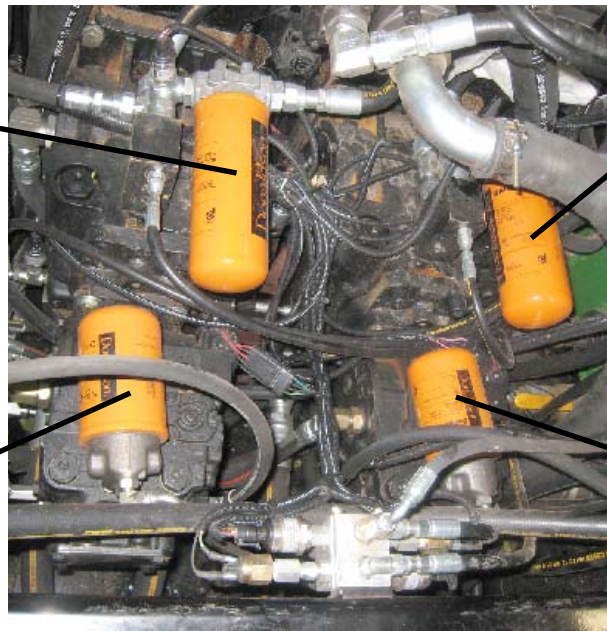

Bandit

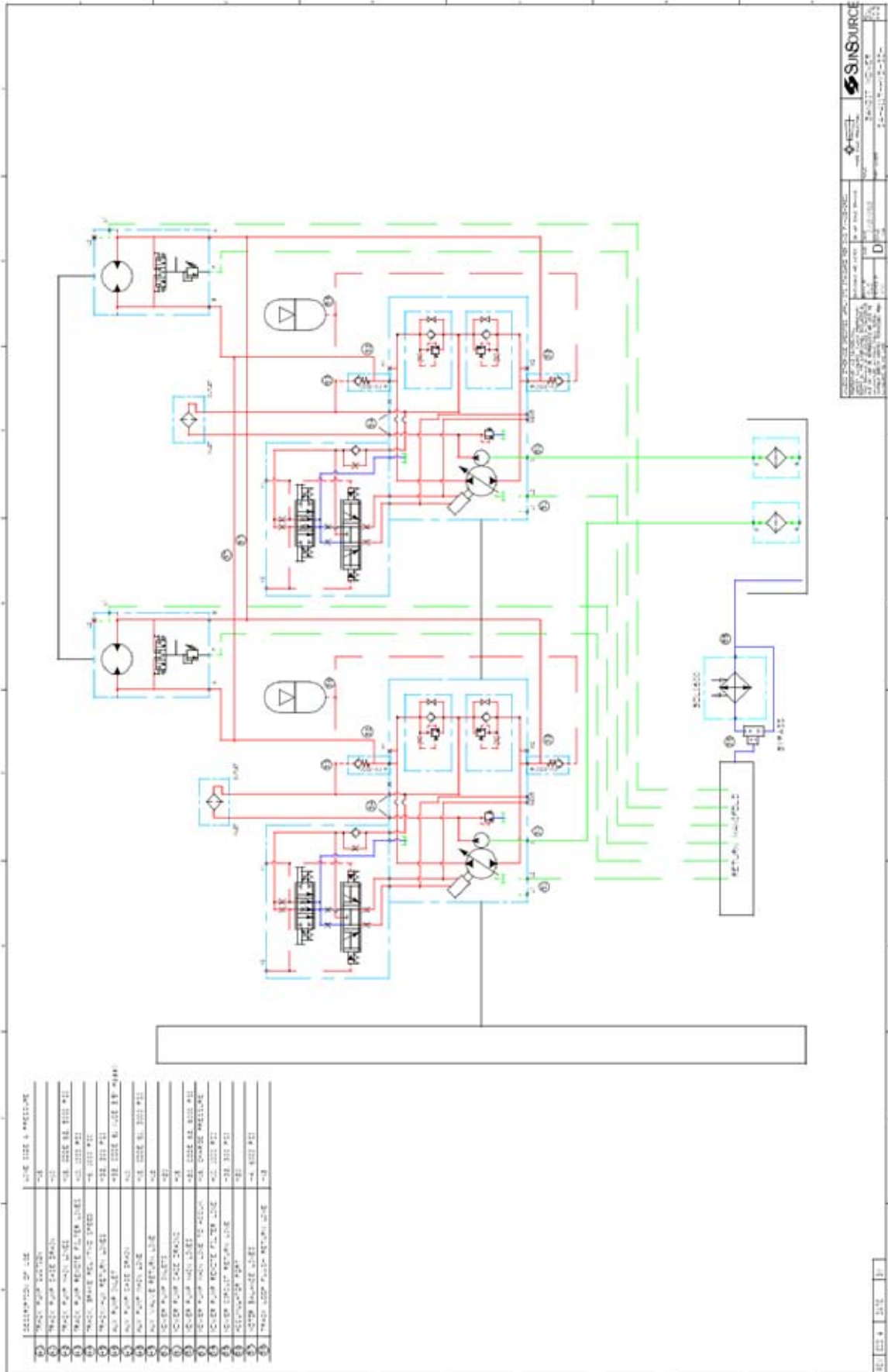

SPECIFIC SCHEMATIC FUNCTION MAY VARY DEPENDING ON OPTIONS OR COMPONENT MANUFACTURER.



HYDRAULIC DIAGNOSTIC GAUGES

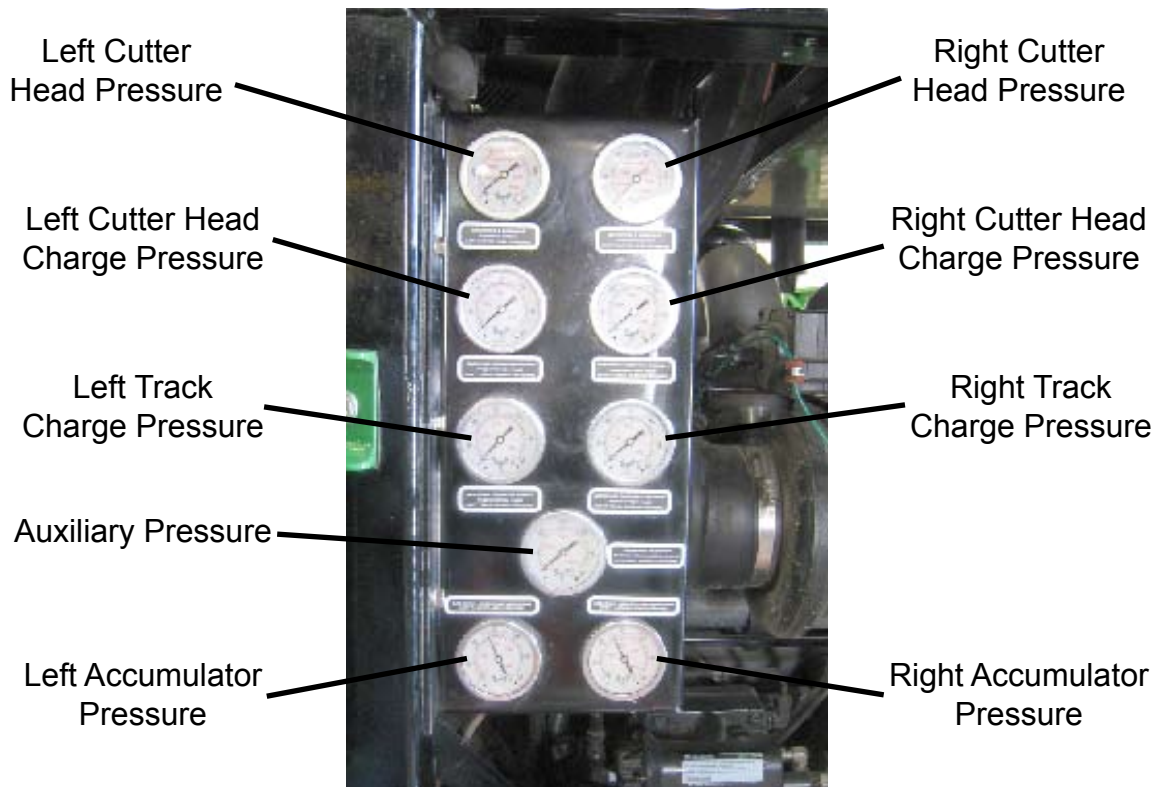

Hydraulic diagnostic gauges located behind the left side engine door in the upper left hand corner.

CUTTER HEAD SECTION

⚠ DANGER

Before attempting any type of maintenance disengage clutch (if equipped), turn off engine, wait for the cutter head to come to a complete stop, turn the battery disconnect to the off position, and make sure the ignition key is in your possession.

⚠ DANGER

Never work under or around the cutter head without first disengaging the clutch, turning off the engine, waiting for the cutter head to come to a complete stop, turning the battery disconnect switch off, and make sure the ignition key is in your possession. Make sure the cutter head is set on the ground or securely blocked up and also chained before doing any work around or under it.

⚠ DANGER

Never go near cutter head or teeth while engine is running or cutter head is coasting to a stop.

DO NOT OPERATE MACHINE WITHOUT A FULL SET OF CUTTER TEETH. OPERATING MACHINE WITHOUT A FULL SET OF CUTTER TEETH CAN CAUSE EXCESSIVE VIBRATION AND PREMATURE BEARING FAILURE.

Do Not operate machine with extremely worn or broken teeth.

TEETH CHANGING PROCEDURE

There are sixty-six (66) teeth to a complete set on a model 4000T/5000T cutter head.

Use only original equipment manufacturer's cutter teeth. The use of any other aftermarket cutter teeth may cause damage or premature failure to the drive train.

- 1) Read all instructions and Dangers before starting procedures.
- 2) Lift the cutter head off the ground and block it. Do not rely on the hydraulics to hold the cutter head off the ground.
- 3) Follow all pre-maintenance shut down procedures.
- 4) Check the cutter head and mower attachment for elongated bolt holes, secure welds, torqued bolts, excessive wear and impact cracks. If a problem is found contact the machine manufacturer or an authorized Bandit dealer.
- 5) Check condition of cutter teeth, tool holders, and attaching hardware. Look for, find, and tighten any component that has loosened up, become damaged, or is missing. Replace if necessary. Cutter teeth bolts must be replaced after a maximum of 4-5 rotations/changes to insure safe clamping ability. Torque cutter teeth bolts to 376 ft-lbs (509 Nm).

NOTICE

It is a good practice to stop after 20 or 30 minutes of running new cutter teeth in order to retighten any loose bolts to their specified torque.

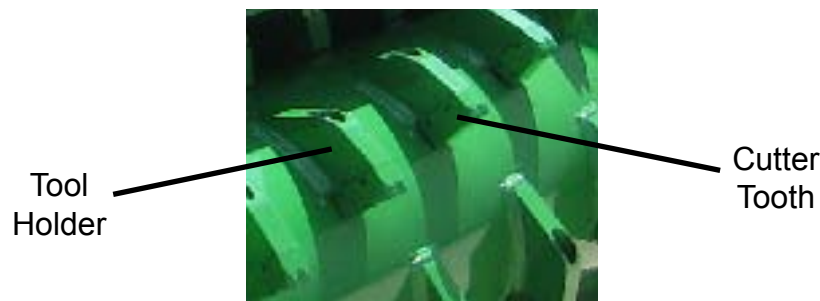

Bandit

CUTTER WHEEL SECTION

DO NOT OPERATE MACHINE WITHOUT A FULL SET OF TEETH. OPERATING MACHINE WITHOUT A FULL SET OF TEETH CAN CAUSE EXCESSIVE VIBRATION AND PREMATURE BEARING FAILURE.

Use only original equipment manufacturer's teeth. The use of any other aftermarket teeth may cause damage or premature failure to the drive train.

There are forty (40) Buck teeth to a complete set on models 4000T/5000T. Two (2) straight c'bored teeth, two (2) straight threaded teeth, eighteen (18) angle c'bored teeth, and eighteen (18) angle threaded teeth.

Do Not operate machine with extremely worn or broken teeth.

A locking pin is provided to hold the cutter wheel in position during tooth removal and reinstallation. Locking pin will only lock on cutter head motor. **NEVER USE HAND ON CUTTER WHEEL TO HOLD IN PLACE WHILE CHANGING TEETH. BE SURE TO REMOVE LOCKING PIN BEFORE OPERATING THE MACHINE.**

BUCK TOOTH ARRANGEMENT

Inspect teeth and bolts for damage and replace as required.

When replacing teeth, always replace new teeth across from each other (180°) in order to prevent vibration.

Replacement teeth must be carbide tipped and of like design as provided with the machine.

Use anti-seize on threads to help prevent bolts from "freezing up" in cutter wheel pockets.

When replacing complete set of teeth, be sure to duplicate original factory tooth arrangement. Typically a 3/4" allen key socket is required to change or torque the teeth. Torque bolts to 600 ft.-lbs. (813 Nm).

Straight teeth are mounted in **TWO OPPOSING OUTSIDE POCKETS** (180°). The pockets are machined out so the tooth sets inside the cutter wheel.

A straight tooth must have an angle tooth accompanying it in the same pocket set. The opposite pocket set should have this same combination of straight and angle tooth, except with positions reversed. Mounting these teeth opposite each other on the cutter wheel reduces damaging vibration.

All Inside Pockets require angle teeth mounted away from the cutter wheel.

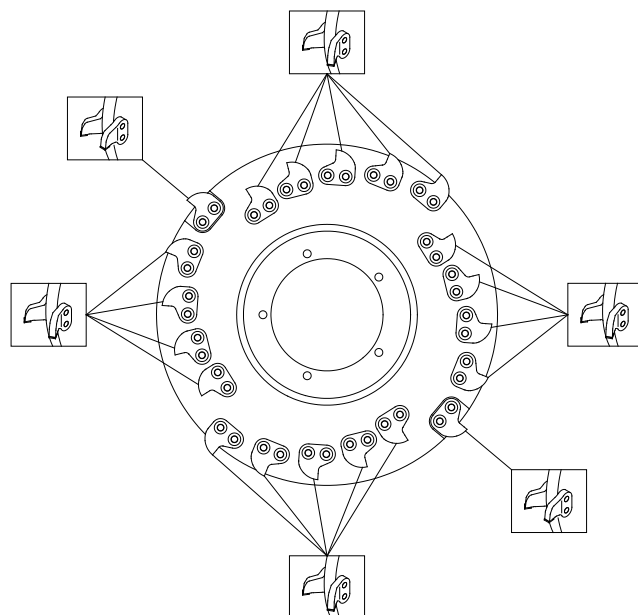

MODELS 4000T/5000T

Angle Threaded Tooth (Right):	900-9909-41
Angle C'Bored Tooth (Left):	900-9909-42
Straight Threaded Tooth (Right):	900-9909-43
Straight C'Bored Tooth (Left):	900-9909-44
Bolt:	900-9909-45

NOTICE Parts may not be exactly as shown.

Bandit

LUBRICATION & COOLANT

- 1) **Engine:** Follow original equipment manufacturers requirements for both changing oils and filters, refer to engine manual specifications.
- 2) **Engine Coolant:** Refer to engine manufacturers manual specifications.
- 3) **Tracks:** Follow track manufacturer's requirements for specific track lubricating procedures.
- 4) **Hydraulic Pump Gear Box:** Check the gear lube level daily and keep it full (is to the correct level on the dipstick). Change gear lube after first 100 hours or 6 months which ever comes first, then every 6 months or every 2000 hours afterwards, which ever comes first. Requires approximately 10 quarts (9.46 L) of 85W/90 type gear lube. See pages 46 -47.
- 5) **Hydraulic Reservoir Tanks:** Completely change hydraulic oil, suction screens, and flush the tanks annually. Change hydraulic oil filter AFTER FIRST 10 HOURS OF OPERATION. Then change hydraulic oil filter every 400 hours or 3 months thereafter. Maintain hydraulic oil level 7/8 full. See hydraulic oil requirements below. Check hydraulic oil level in tanks daily.
- 6) **Hydraulic Fluid Requirements:** See pages 49 - 50 for hydraulic fluid requirements.
- 7) **Charge Filters (total of 4):** Change charge filters AFTER FIRST 10 HOURS OF OPERATION. Then change charge filters every 400 hours or 3 months thereafter. Located on the pumps behind the operator's cab.
- 8) **Mower Head Bearings (if equipped):** Grease each cutter head bearing daily. Use one (1) or shot for each hour the machine was used of EP-2 Lithium type grease (example: if the machine was used for 8 hours, each bearing would require 8 pumps of grease). Wipe off excessive grease. **Excessive grease will attract dirt.**
- 9) **Mower Overhung Load Adapter (if equipped):** Grease both zerks on each overhung load adapter yearly with one (1) or two (2) shots of EP-2 Lithium type grease. Wipe off excess grease. **Excessive grease will attract dirt.**
- 10) **Stump Grinder Swing Pivot Bushings (if equipped):** Grease the top and bottom stump grinder swing pivot bushings weekly. Use one (1) or two (2) shots of EP-2 Lithium type grease. Wipe off excess grease. **Excessive grease will attract dirt.**
- 11) **Cylinder Lug Pin Bushings:** Grease cylinder lug pin bushings daily. Use one (1) or two (2) shots of EP-2 Lithium type grease. Wipe off excess grease. **Excessive grease will attract dirt.**
- 12) **Cab Tilt Pump Reservoir:** Check the hydraulic oil level in the reservoir daily and keep full. Completely change hydraulic oil and flush the reservoir yearly.
- 13) **Steel Friction Areas:** Lubricate all steel friction areas including, but not limited to pivoting, hinged, sliding, and rotating areas weekly. (i.e. doors, cab tilt hinge, winch rollers, etc.)
- 14) **Windshield Washer Fluid Reservoir:** Check and fill the windshield washer fluid reservoir weekly. Located under the cab on the back of the right hand side fuel tank.

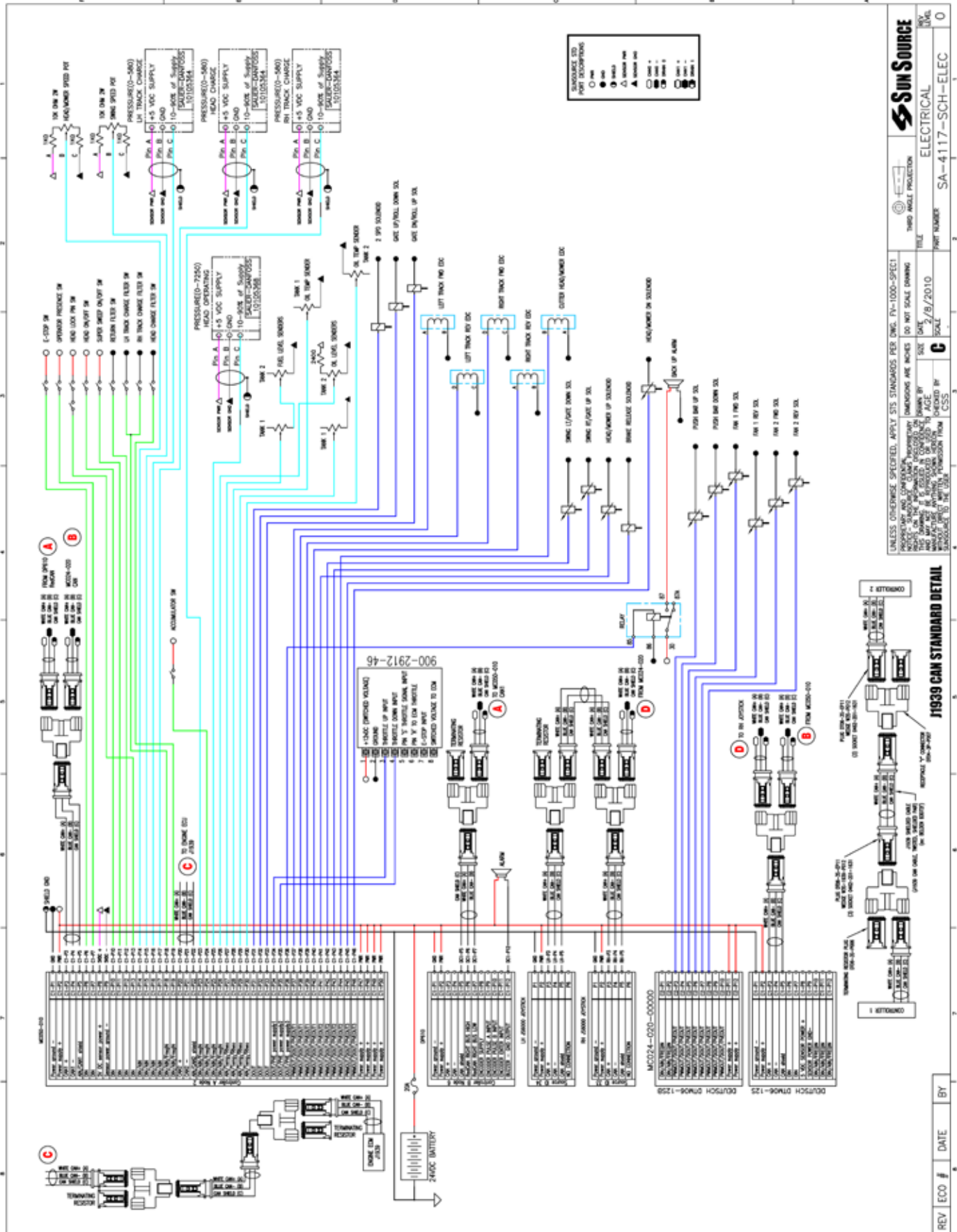

SPECIFIC SCHEMATIC FUNCTION MAY VARY DEPENDING ON OPTIONS OR COMPONENT MANUFACTURER.

Bandit

CAB FUSE PANEL

F11 POWER OUTLET 1 10A	F1 AIR CONDITIONER 15A
F12 POWER OUTLET 1 10A	F2 PRESSURIZED CAB FAN 10A
F13 POWER OUTLET 1 10A	F3 WORK LIGHTS 20A
F14 MIRRORS 15A	F4 WINDSHIELD WIPER 10A
F15 RADIO 10A	F5 PLUS ONE 20A
F16 SPARE	F6 ENGINE REVERSING FAN 10A
F17 SPARE	F7 ATTACHMENT LOCK PIN 5A
F18 SPARE	F8 WINCH 5A
F19 SPARE	F9 BACK-UP CAMERA 5A
F20 SPARE	F10 SPARE



The cab fuse panel is located between the right hand cab door and the seat.

POWER BOX FUSE & RELAY PANEL

BACK-UP BEEPER RELAY	F1 AIR CONDITIONER 15A
	F2 AIR CONDITIONER CONDENSOR 30A
AIR CONDITIONER COMPRESSOR RELAY	F3 AIR CONDITIONER COMPRESSOR 5A
	F4 WINCH 5A
	F5 HORN 10A
	F6 SPARE
	F7 SPARE
	F8 SPARE
SPARE	F9 SPARE
	F10 SPARE



The power box fuse & relay panel is located on the right hand side of the engine on the cab power box.

REPLACEMENT PARTS SECTION

Depending on what replacement parts you are ordering the following information will be needed:

CHIPPER COMPONENTS

Serial Number
Model Number of Grinder

ENGINE COMPONENTS

Brand
Engine Serial Number
Engine Spec. Number

CLUTCH COMPONENTS

Brand
Serial Number
Assembly Number of Clutch

NOTICE

When ordering any replacement parts you should have the serial number (S/N) and model of the machine to ensure that you receive the correct replacement part. See page 6 for typical serial number & work order number locations.

NOTICE

All nuts, bolts, washers, and many other components can be ordered by physical description.

NOTICE

Some of the components shown in this section are for optional equipment and may not apply to every machine.

NOTICE

Bandit Industries Inc. reserves the right to make changes in models, size, design, installations and applications on any part without notification.

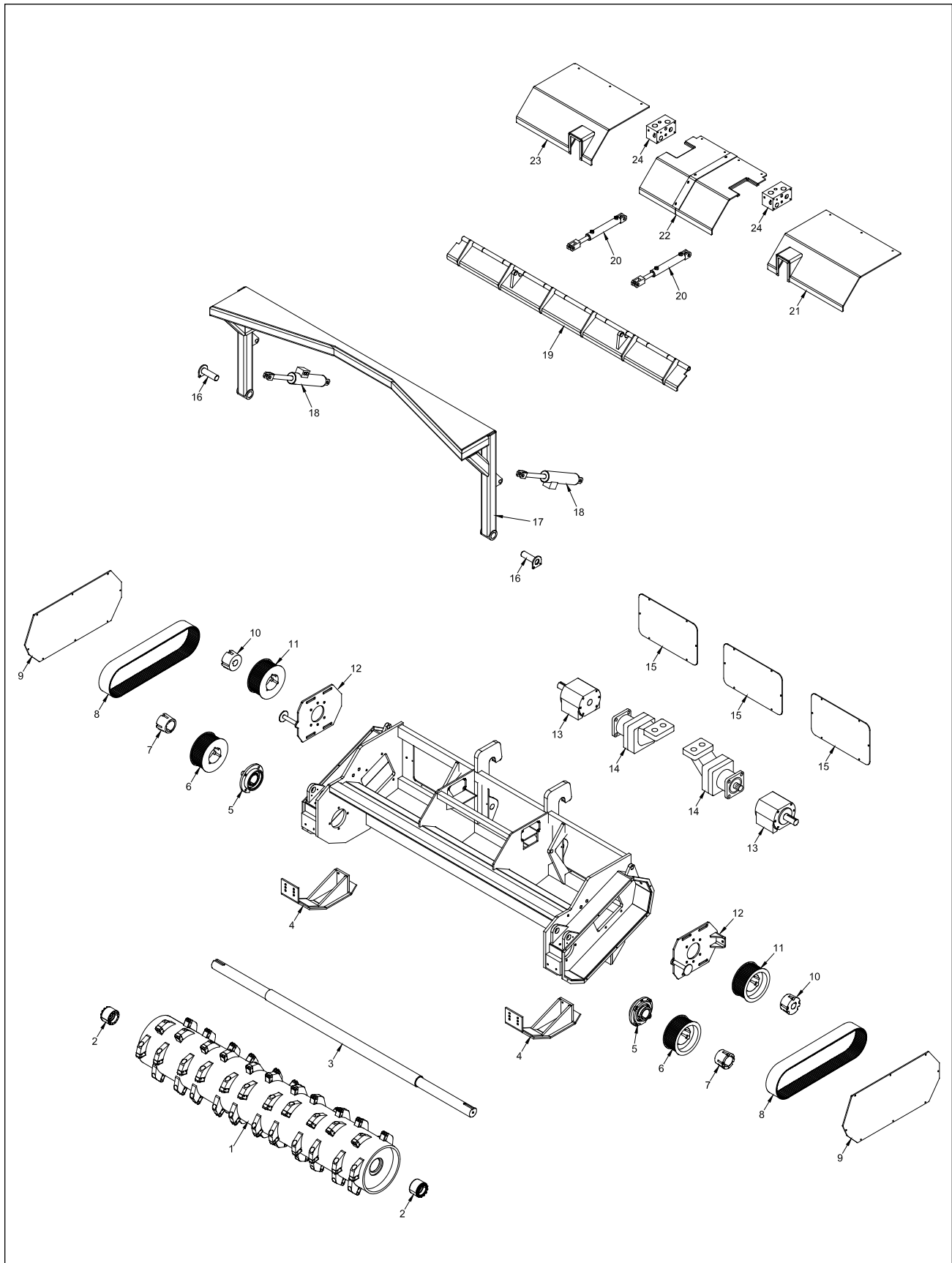

NOTICE Parts may not be exactly as shown.

Bandit

LOCATION	PART NUMBER	DESCRIPTION
1 a.	988-2002-99	Forestry Mower Drum Assembly
b.	900-9903-14	Cutter Head Tooth (66 Per Head)
c.	900-4902-77	3/4" - 10NC x 2 1/4" Hex Head Bolt
d.	900-4905-91	3/4" NordLock Washer
2.	900-1916-78	Taper Lock Bushing
3.	988-3016-34	Cutter Head Shaft
4.	988-2002-92	Skid Plate - (Specify Road Side Or Curb Side)
5.	900-1916-85	Cutter Head Bearing
6.	900-1916-74	Sheave - Forestry Mower
7.	900-1916-96	Bushing - Forestry Mower
8.	900-1916-87	Forestry Mower Belt (Poly Chain)
9.	988-3015-84	Belt & Sheave Cover
10.	900-1916-97	Bushing - Hydraulic Motor
11.	900-1916-88	Sheave - Hydraulic Motor
12.	988-2002-87	Motor Mount Assembly
13.	900-3946-06	Bearing Block
14.	900-3948-05	Cutter Head Motor
15.	988-3015-91	Rear Cover For Mower
16.	988-2002-22	Pin For Push Bar
17.	988-2002-91	Push Bar Assembly
18.	900-3927-84	Push Bar Cylinder
19.	988-2002-93	Gate Assembly
20.	900-3925-03	Gate Cylinder
21.	988-2002-96	Top Cover For Mower - Road Side
22.	988-2002-88	Top Cover Assembly For Mower - Middle
23.	988-2002-95	Top Cover For Mower - Curb Side
24.	900-3947-00	Cutter Head Manifold
25.	988-1000-72	Forestry Mower Assembly - 108" Cut

NOTICE Nuts, bolts, washers, and all other components can be ordered by physical description.

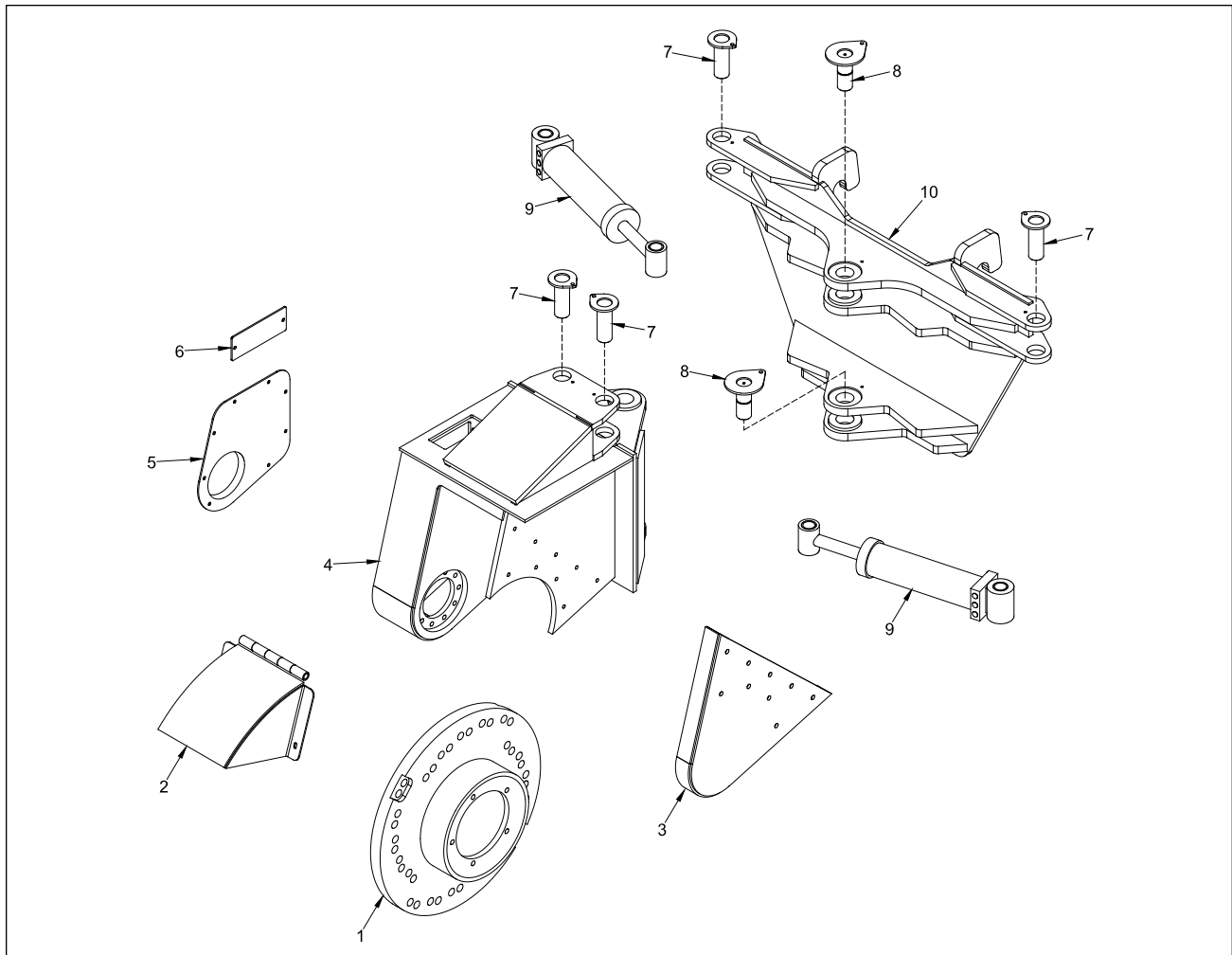

LOCATION	PART NUMBER	DESCRIPTION
1.	988-1000-77	Cutter Wheel Assembly
2.	988-2001-09	Chip Guard
3.	988-2001-07	Cutter Head Removable Guard
4.	988-2001-08	Cutter Head Pivot Assembly
5.	988-2001-05	Cutter Wheel Motor & Hose Guard
6.	988-3007-52	Cutter Head Side Cover
7.	988-200083	Swing Cylinder Pin
8.	988-200089	Swing Pin
9.	900-3941-02	Swing Cylinder
10.	988-200075	Quick Attach Plate Assembly

NOTICE Nuts, bolts, washers, and all other components can be ordered by physical description.

NOTICE Parts may not be exactly as shown.



LOCATION	PART NUMBER	DESCRIPTION
1.	900-9909-41	Angle Threaded Tooth (Right)
2.	900-9909-42	Angle C'Bored Tooth (Left)
3.	900-9909-43	Straight Threaded Tooth (Right)
4.	900-9909-44	Straight C'Bored Tooth (Left)
5.	900-9909-45	Bolt
6.	--	--

NOTICE Parts may not be exactly as shown.

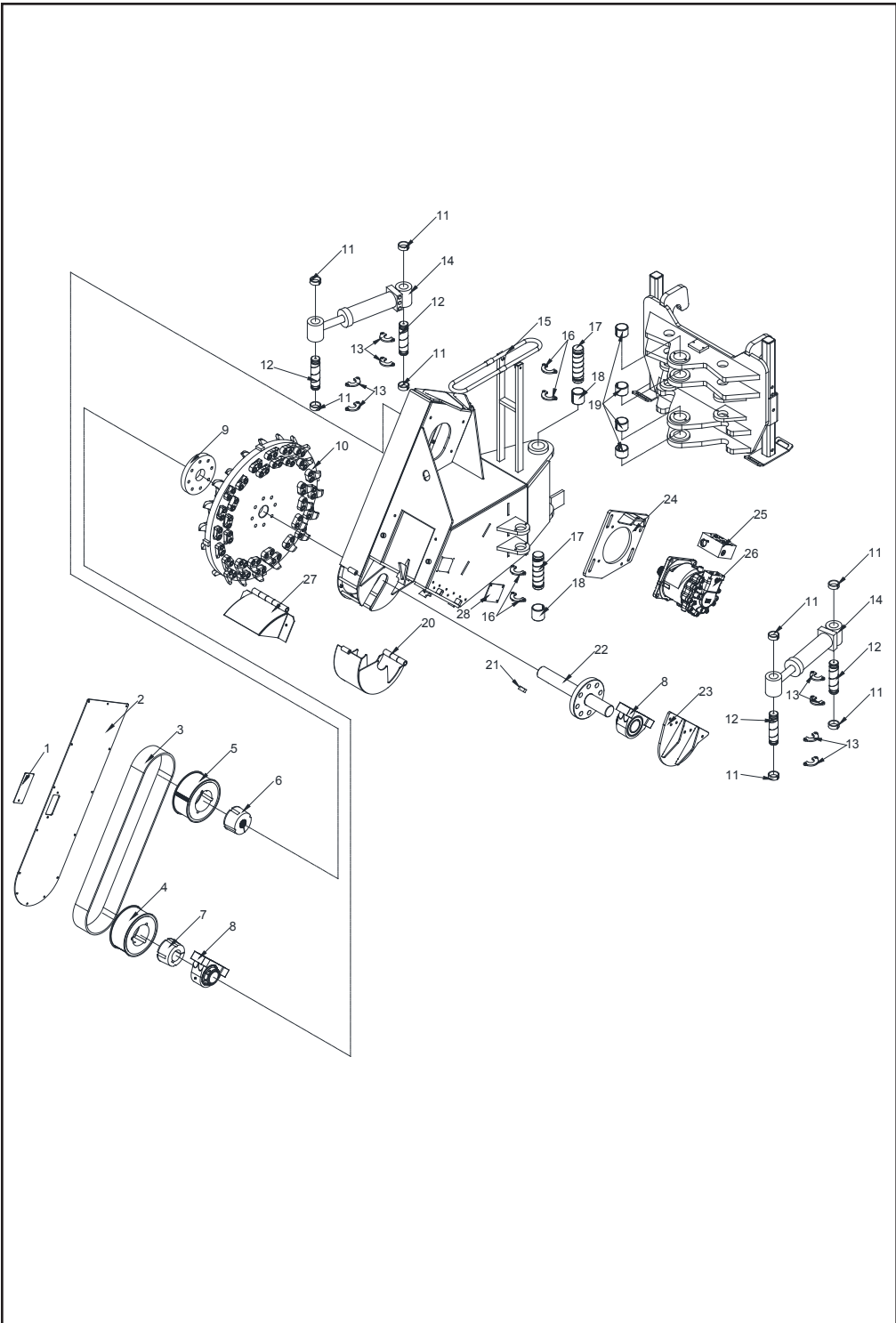

NOTICE Parts may not be exactly as shown.

LOCATION	PART NUMBER	DESCRIPTION
1.	988-3024-48	Beltshield Inspection Cover
2.	988-3024-42	Beltshield Cover
3.	900-1921-95	Cutter Wheel Belt
4.	900-1921-96	Cutter Wheel Sheave
5.	900-1921-96	Cutter Wheel Motor Sheave
6.	900-1921-99	Cutter Wheel Motor Bushing
7.	900-1921-97	Cutter Wheel Bushing
8.	900-1921-98	Cutter Wheel Bearing
9.	988-3024-63	Cutter Wheel Draw Ring
10 a.	987-3012-89	Cutter Wheel
b.	900-9909-45	Socket Head Cap Screw for Tooth
c.	900-9909-42	Counter Bored Tooth
d.	900-9909-41	Threaded Tooth
11.	900-1915-02	Split Bushing - 3" OD x 2 1/2" ID x 1"
12.	987-3005-28	Swing Cylinder Pin
13.	987-3004-79	Keeper for Cylinder Pin
14.	900-3948-40	Swing Cylinder
15.	988-2003-30	Hose Keeper
16.	987-3011-46	Keeper for Swing Pivot Pin
17.	988-3024-58	Pin for Swing Pivot
18.	900-1921-93	Split Bushing - 3 1/2" OD x 3" ID x 3 1/2"
19.	900-1921-94	Split Bushing - 3 1/2" OD x 3" ID x 2 1/2"
20.	988-2004-34	Hinged Beltshield End
21.	987-3011-54	Key
22.	988-2004-28	Cutter Wheel Shaft
23.	988-2004-27	Bearing Guard
24.	988-2004-30	Belt Adjuster Assembly
25.	900-3967-42	Cutter Wheel Relief
26.	900-3966-17	Cutter Wheel Motor
27.	994-2000-63	Cutter Wheel Guard
28.	988-3024-75	Grease Line Access Cover

NOTICE Nuts, bolts, washers, and all other components can be ordered by physical description.

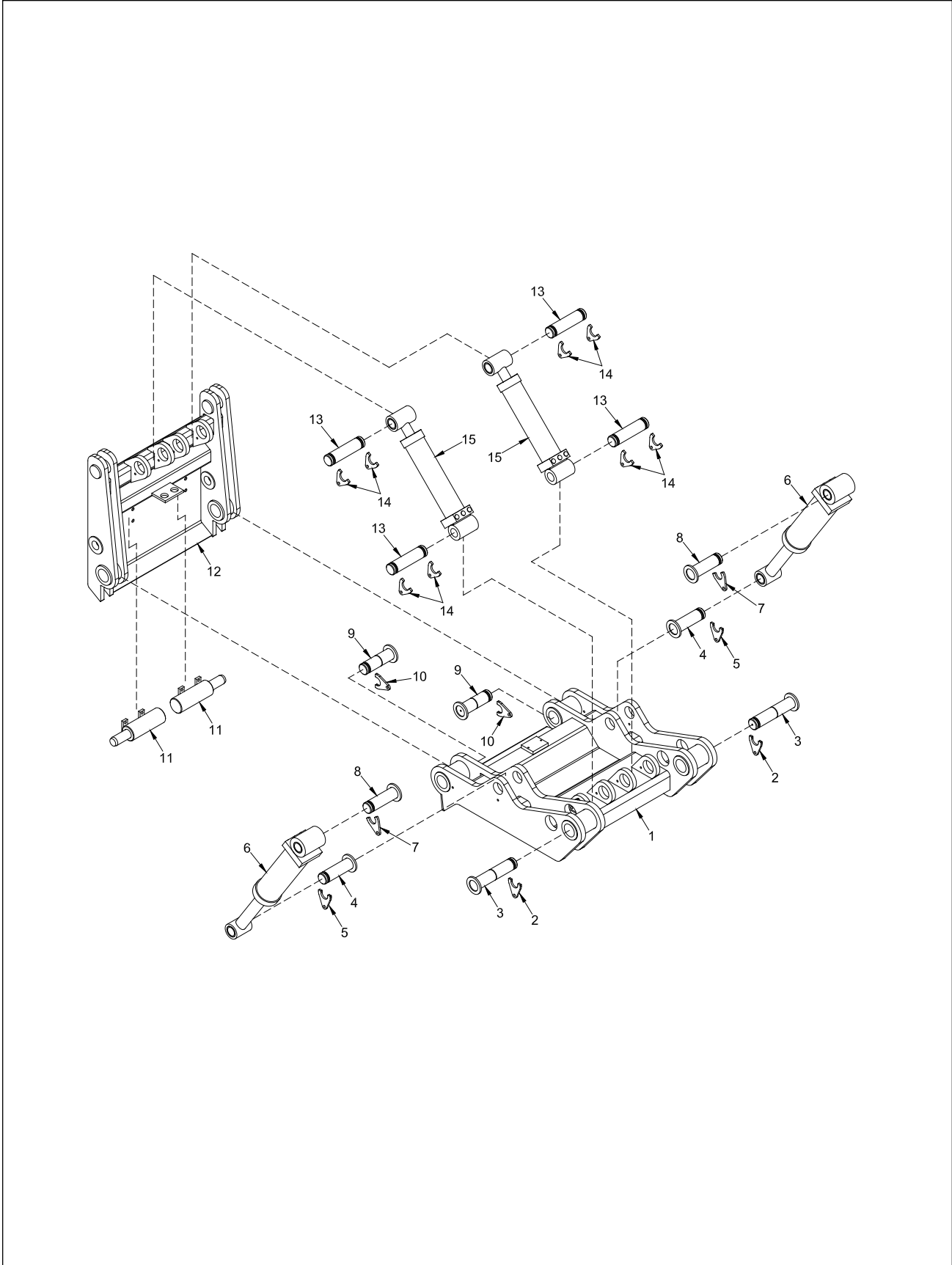

NOTICE Parts may not be exactly as shown.

Bandit

LOCATION	PART NUMBER	DESCRIPTION
1.	988-2002-89	Quick Attach Main Assembly
2.	988-3013-55	Pin Retainer
3.	988-2002-29	Lower Main Attaching Pin
4.	988-2002-31	Pin For Up / Down Cylinder - Rod End
5.	988-3013-55	Pin Retainer
6.	900-3940-28	Up / Down Cylinder
7.	988-3013-54	Pin Retainer
8.	988-2002-31	Pin For Up / Down Cylinder - Ram End
9.	988-2002-30	Up / Down To Tilt Pin - Greaseable
10.	988-3013-55	Pin Retainer
11.	900-3941-01	Lock Cylinder
12.	988-2002-90	Quick Attach Tilt Assembly
13.	988-3013-50	Pin For Tilt Cylinder
14.	988-3013-54	Pin Retainer
15.	900-3940-27	Tilt Cylinder
16.	988-1000-73	Quick Attachment Assembly

NOTICE Nuts, bolts, washers, and all other components can be ordered by physical description.

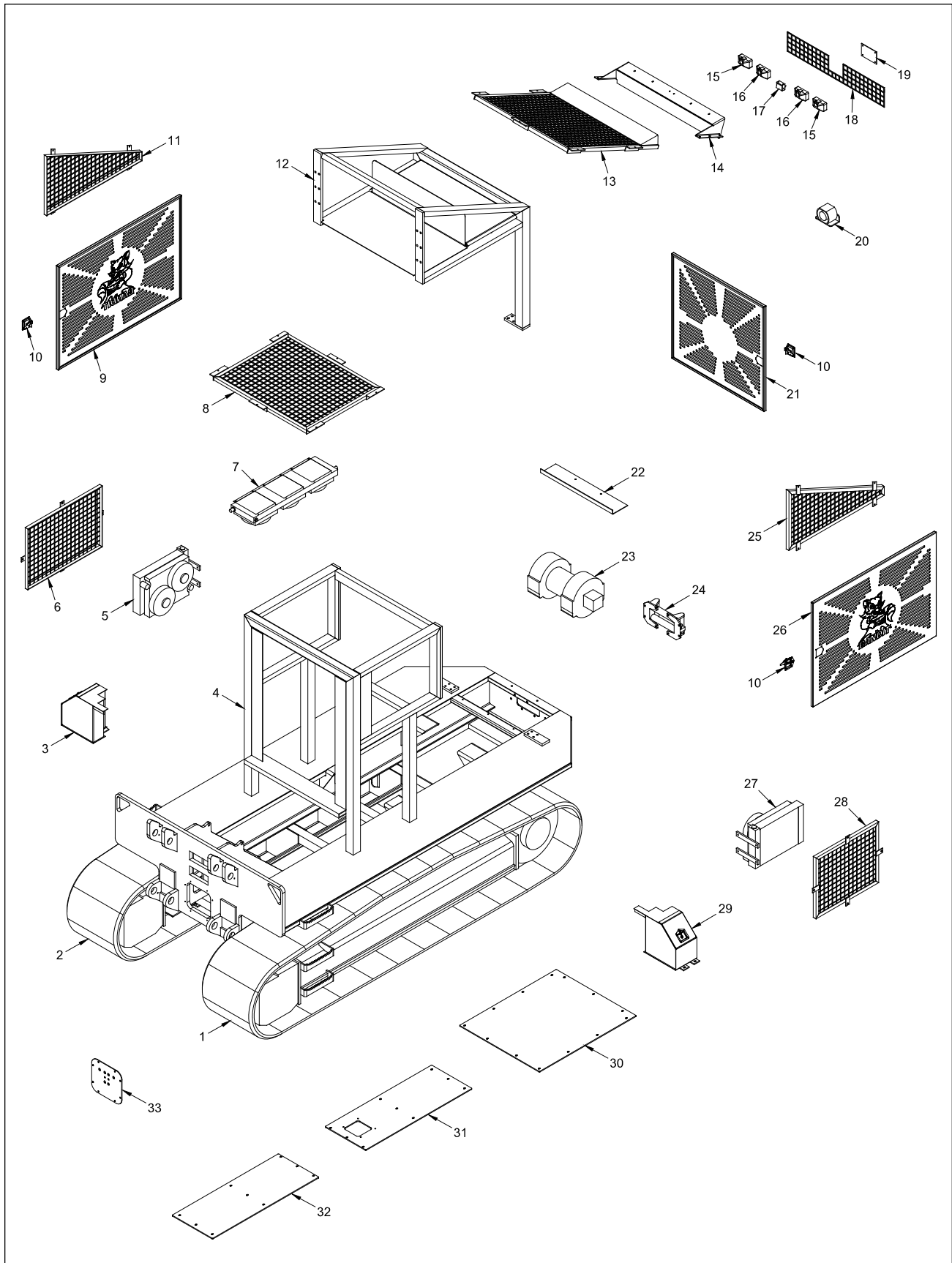

NOTICE Parts may not be exactly as shown.

Bandit

LOCATION	PART NUMBER	DESCRIPTION
1.	**	Road Side Track Assembly
2.	**	Curb Side Track Assembly
3 a.	988-2002-33	Tool Box Assembly - Curb Side
b.	900-4908-19	"T" Handle Latch Only
c.	CH545	Key For "T" Handle Latch
4.	988-2002-49	Roll Cage Assembly - Coolers
5.	900-3946-76	Curb Side Oil Cooler - Cutter Head
6.	988-2002-42	Cooler Guard Assembly - Curb Side
7.	900-9908-02	A/C Condenser - 24V
8.	988-2001-94	A/C Condenser Guard Assembly
9 a.	988-3010-88	Engine Door - Curb Side
b.	900-4913-96	Hinge Only
10 a.	900-4908-19	"T" Handle Latch
b.	CH545	Key For "T" Handle Latch
11.	988-2003-06	Upper Side Door Assembly - Curb Side
12.	988-2002-70	Roll Cage Assembly - Engine
13.	988-2003-08	Roll Cage Top Door Assembly
14.	988-2001-95	Work Light & Camera Mount
15.	900-2921-64	Work Light - Flood
16.	900-2921-65	Work Light - Trapezoid
17.	900-2919-07	Back-Up Camera
18.	988-2003-07	Light Guard Assembly
19.	988-3011-20	Back-Up Camera Cover
20.	900-2907-52	Back-Up Beeper
21 a.	988-3011-22	Rear Engine Door
b.	900-4913-96	Hinge Only
22.	988-3016-93	Winch Cover
23.	900-3941-45	Winch
24.	900-3941-46	Winch Roller Fairlead
25.	988-2003-05	Upper Side Door Assembly - Road Side
26 a.	988-3010-87	Engine Door - Road Side
b.	900-4913-96	Hinge Only
27.	900-3946-76	Road Side Oil Cooler - Tracks / Auxiliary
28.	988-2002-42	Cooler Guard - Road Side
29 a.	988-2002-45	Tool Box Assembly - Road Side
b.	900-4908-19	"T" Handle Latch Only
c.	CH545	Key For "T" Handle Latch
30.	988-3011-14	Rear Skid Plate
31.	988-3014-46	Skid Plate
32.	988-3014-47	Skid Plate
33.	988-3007-89	Front Plate Hose Cover

** Track Assemblies and components vary with options, order by S/N of machine or physical description.

NOTICE Nuts, bolts, washers, and all other components can be ordered by physical description.

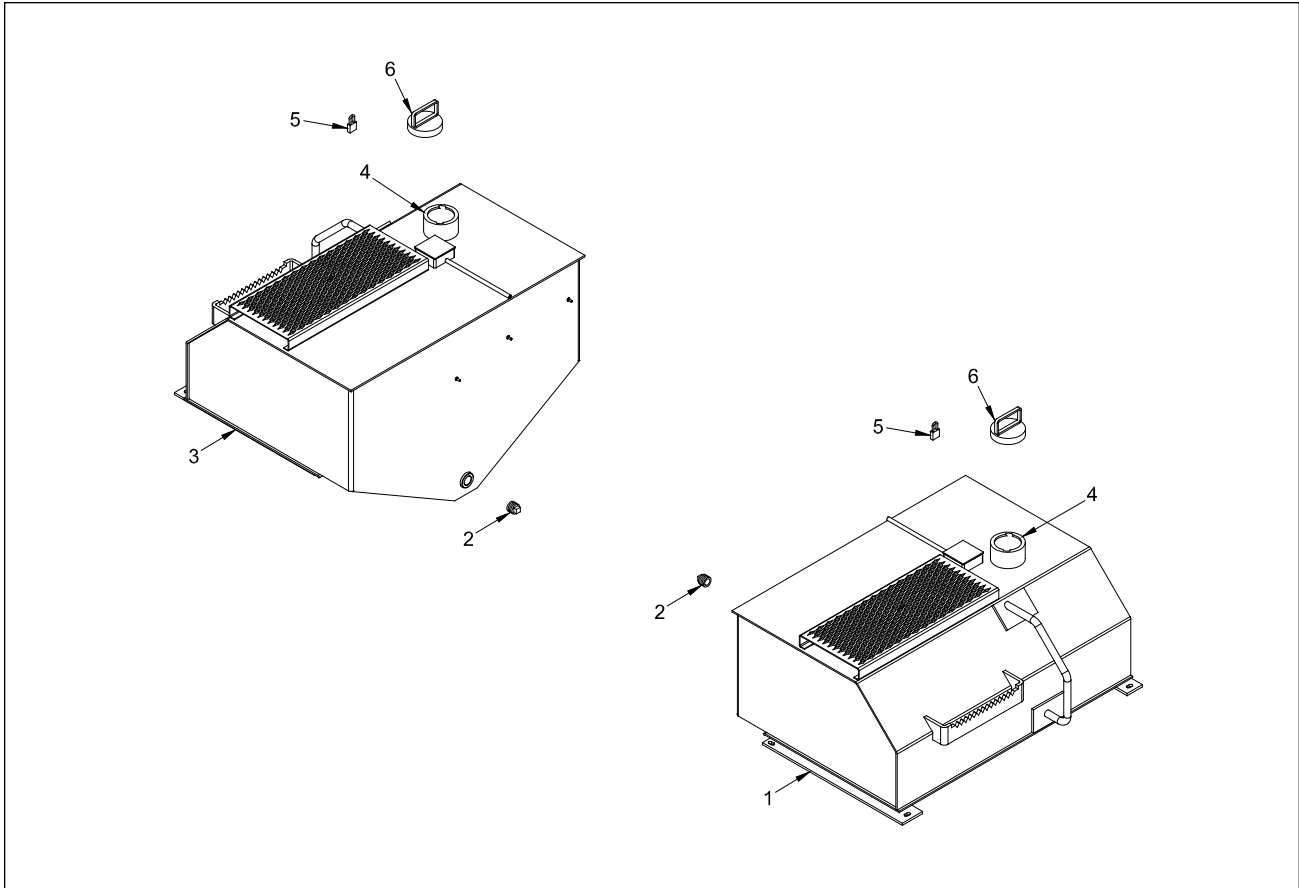

LOCATION	PART NUMBER	DESCRIPTION
1.	988-2002-78	Road Side Fuel Tank Assembly - 110 Gallon (416 L)
2.	900-3922-60	Magnetic Drain Plug
3.	988-2002-77	Curb Side Fuel Tank Assembly - 110 Gallon (416 L)
4 a.	900-3947-92	Filler Neck With Lock
b.	900-3947-93	Filler Basket - 12"
5 a.	900-4912-40	Padlock With Short Shackle For Tank With Locking Cap
b.	P812	Key For Padlock (Not Shown)
6.	900-3947-90	Diesel Fuel Cap With Lock Tab & Chain
7.	900-2920-31	Fuel Level Sensor (Not Shown)

NOTICE Tank assemblies vary with options.
Specify all options when ordering.

NOTICE Parts may not be exactly as shown.

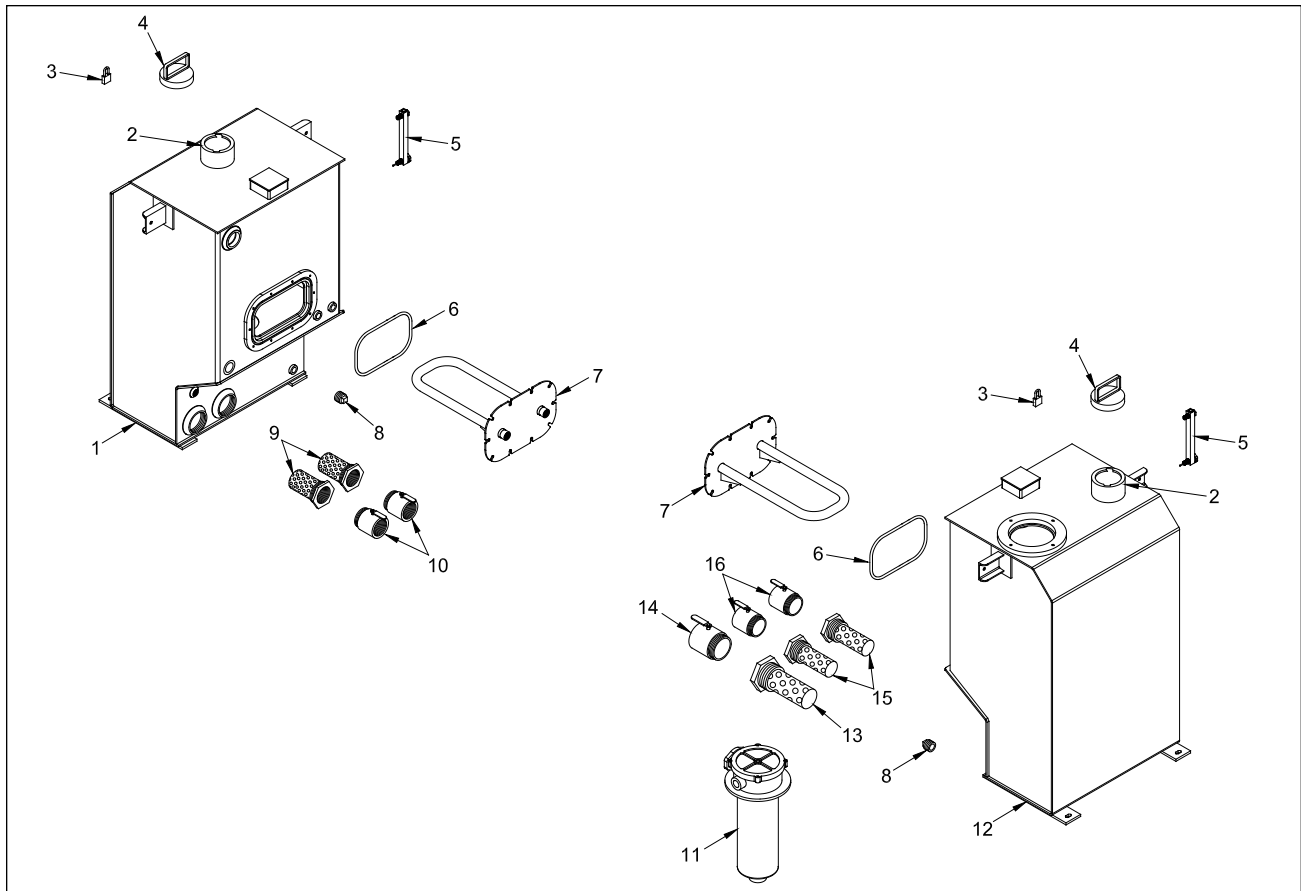

LOCATION	PART NUMBER	DESCRIPTION
1.	988-2002-80	Curb Side Hydraulic Tank Assembly - Cutter Head - 82 Gallon (310 L)
2 a.	900-3947-92	Filler Neck With Lock
b.	900-3947-93	Filler Basket - 12"
3 a.	900-4912-40	Padlock With Short Shackle For Tank With Locking Cap
b.	P812	Key For Padlock (Not Shown)
4.	900-3947-91	Hydraulic Fuel Cap With Lock Tab & Chain
5.	900-3901-78	Temperature/Sight Gauge
6.	900-7901-32	Rubber O-ring
7.	988-2002-07	Heater Core / Clean Out Door - Hydraulic Tank
8.	900-3922-60	Magnetic Drain Plug
9.	900-3907-05	Suction Screen
10.	900-3920-14	Ball Valve - 1 1/2"
11 a.	900-3946-82	In-Tank Return Filter Assembly
b.	900-3947-45	Filter Element Only
12.	988-2002-79	Road Side Hydraulic Tank Assembly - Tracks/Auxiliary - 82 Gallon (310 L)
13.	900-3925-22	Suction Screen
14.	900-3901-84	Ball Valve - 2"
15.	900-3907-05	Suction Screen
16.	900-3920-14	Ball Valve - 1 1/2"
17.	900-2920-30	Fuel Level Sensor (Not Shown)

NOTICE Tank assemblies vary with options.
Specify all options when ordering.

NOTICE Parts may not be exactly as shown.

Bandit

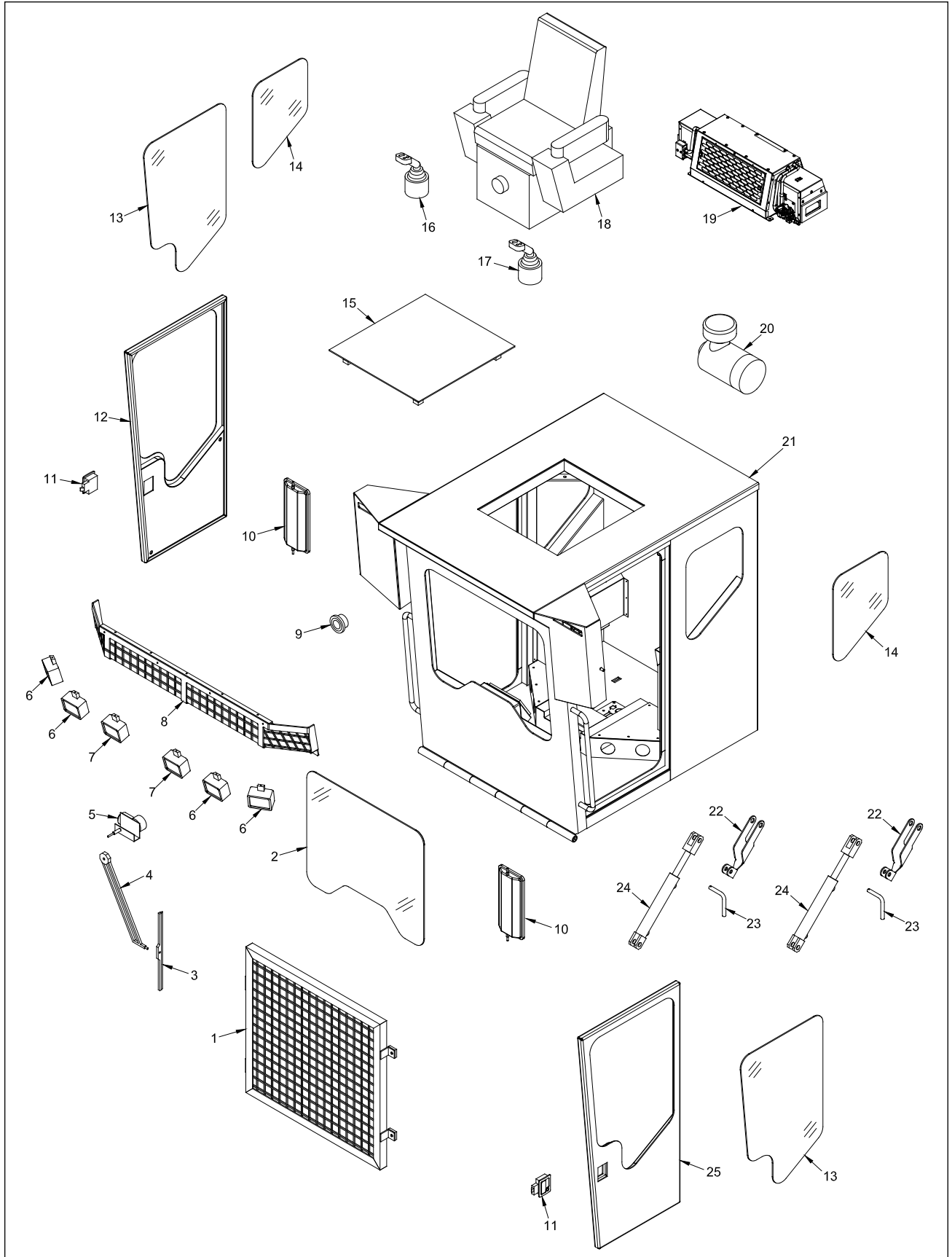

NOTICE Parts may not be exactly as shown.

Bandit

LOCATION	PART NUMBER	DESCRIPTION
1.	988-2002-98	Front Window Guard Assembly
2 a.	988-3015-70	Front Window
b.	900-8900-07	Window Seal
3.	900-2922-05	Window Wiper
4.	900-2921-96	Wiper Arm
5.	900-2922-11	Window Wiper Motor
6.	900-2921-64	Work Light - Flood
7.	900-2921-65	Work Light - Trapezoid
8.	988-2002-97	Light Guard Assembly
9.	900-9909-20	Heated Mirror
10.	900-2900-54	Horn
11.	900-4915-66	Door Handle
12.	988-2002-50	Door Assembly - Right Side
13 a.	988-3015-71	Right Side Door Window
b.	900-8900-07	Window Seal (Not Shown)
14 a.	988-3015-72	Side Window
b.	900-8900-07	Window Seal (Not Shown)
15.	988-2002-94	Escape Hatch Door Assembly
16.	900-2916-11	Right Joystick
17.	900-2916-10	Left Joystick
18.	900-9909-17	Operator's Chair Only
19.	900-9908-66	A/C & Heater Unit
20 a.	900-9909-16	Cab Air Filter Assembly
b.	900-6913-70	Primary Filter Element Only
21.	988-2002-72	Cab Assembly
22.	988-3009-70	Cylinder Lock
23.	955-300086	Cylinder Lock Pin
24.	900-3925-03	Cab Tilt Cylinder
25.	988-2002-51	Door Assembly - Left Side

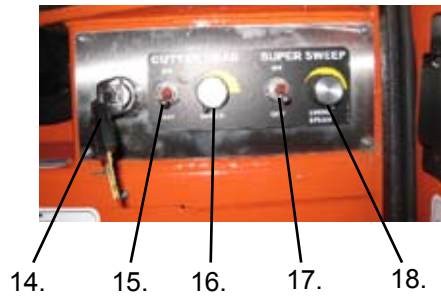
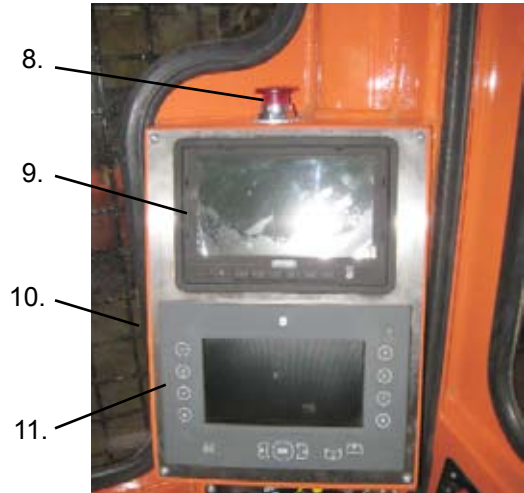
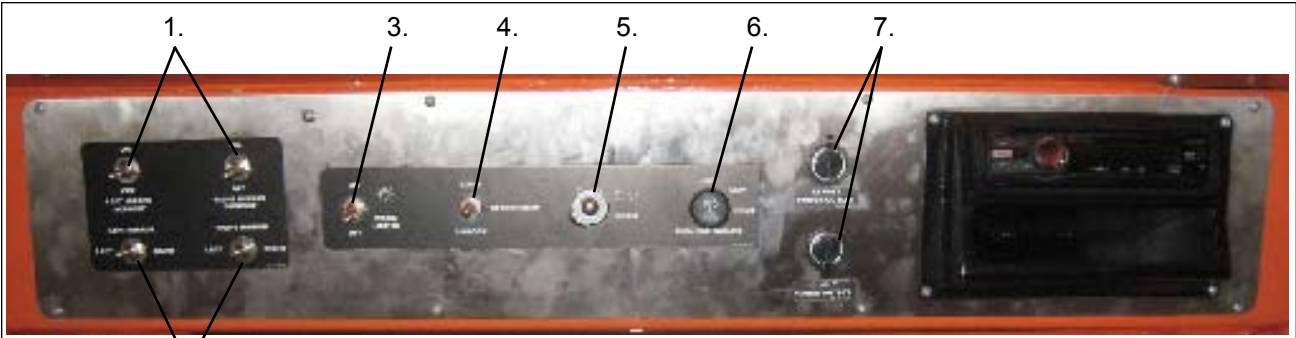

NOTICE Parts may not be exactly as shown.

LOCATION	PART NUMBER	DESCRIPTION
1.	900-2910-46	Mirror Defrost Switch
2.	900-2921-77	Mirror Adjustment Switch
3.	900-2910-46	Work Light Switch
4.	900-2921-78	Attachment Pin Switch
5.	900-2900-54	Horn Button
6.	900-9908-34	Windshield Wiper & Washer Switch
7 a.	900-2914-53	12 Volt Power Outlet
b.	900-2914-54	Power Outlet Cap Only
8 a.	900-2901-03	E-Stop Switch
b.	900-2901-05	Contact Block For E-Stop Switch
9.	900-2919-26	Back-Up Camera Display Screen
10.	900-2904-78	Plus One Fault Alarm
11.	900-2916-09	Plus One System Display
12.	900-2901-95	Manual Fan Purge Switch
13.	900-4908-17	Winch Controller & Tether Jack
14 a.	904-0001-42	Ignition Switch
b.	AR51481	Key For Ignition Switch
15.	900-2910-46	Cutter Head On / Off Switch
16.	900-2922-48	Cutter Head Speed Switch (0 - 100 %)
17.	900-2910-46	Super Sweep On / Off Switch
18.	900-2922-48	Swing Speed Switch (0 - 100 %)

Road Side of Machine

Left Side
Track Pump
900-3946-81



Auxiliary Pump
900-3946-73

Pump Gear
Box

Left Side Cutter
Head Pump
900-2916-14

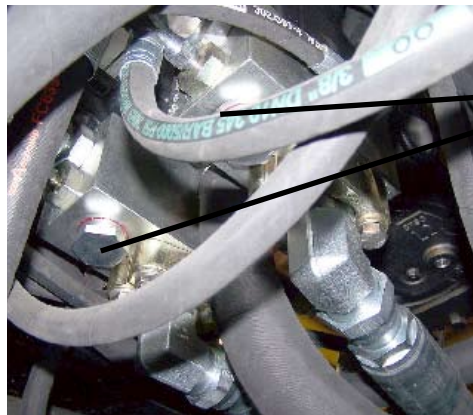

Cutter Head Pump
Port Block With
5 PSI (.3 bar)
Anticavitate Check
Valve (2 Per Cutter
Head Pump)
900-3941-22

Curb Side of Machine

Right Side Cutter
Head Pump
900-2916-14

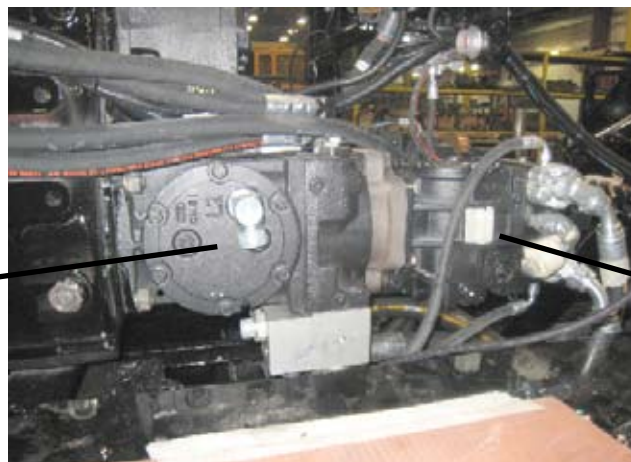

Right Side
Track Pump
900-3946-80

NOTICE Some of the hydraulic components are listed in other component sections.

NOTICE Parts may not be exactly as shown.

Bandit

Charge Filters located behind the cab

Right Side Cutter
Head Charge Filter
900-6911-08

Left Side Cutter
Head Charge Filter
900-6911-08



Right Side Track
Charge Filter
900-6911-08

Left Side Track
Charge Filter
900-6911-08

NOTICE Some of the hydraulic components are listed in other component sections.

NOTICE Parts may not be exactly as shown.

Bandit

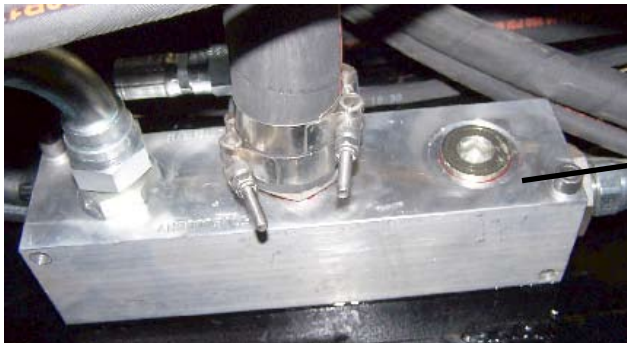

Oil Cooler
Manifold
900-3942-37

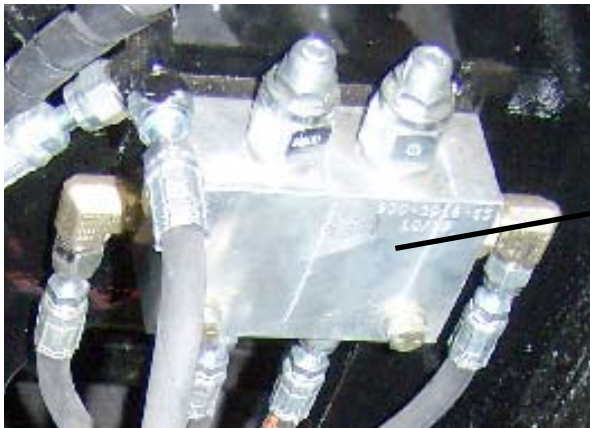

Counter Balance
Valve For Cab Tilt
900-3918-65



8 Section
Control Valve
900-3946-74

NOTICE Some of the hydraulic components are listed in other component sections.

NOTICE Parts may not be exactly as shown.

Bandit



Thermal Transfer
3-Way Bypass
900-3946-83

1-1/2 Gallon Accumulator
(1 Per Cutter Head Motor)
900-3941-10

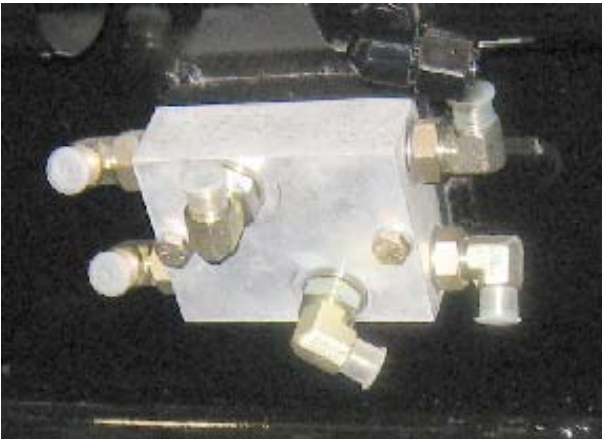

Double Tee Block
(1 Used Per Each Of The Following:
Mower Tilt Cylinders, Attachment Lock
Cylinders, Mower Up / Down Cylinders,
Gate Cylinders, Push Bar Cylinders)
900-3917-50

NOTICE Some of the hydraulic components are listed in other component sections.

NOTICE Parts may not be exactly as shown.

Bandit



Brake Release /
Track Two Speed
Valve

900-3937-58

Coil Only (24V)

900-3946-86

Cartridge Only

900-3935-37



Drive Loop
Flushing Block

900-3941-08



Cab Tilt Electric / Hydraulic
Pump & Valve With 3 Quart
Reservoir & Harness

900-3937-69

NOTICE Some of the hydraulic components are listed in other component sections.

NOTICE Parts may not be exactly as shown.

Bandit

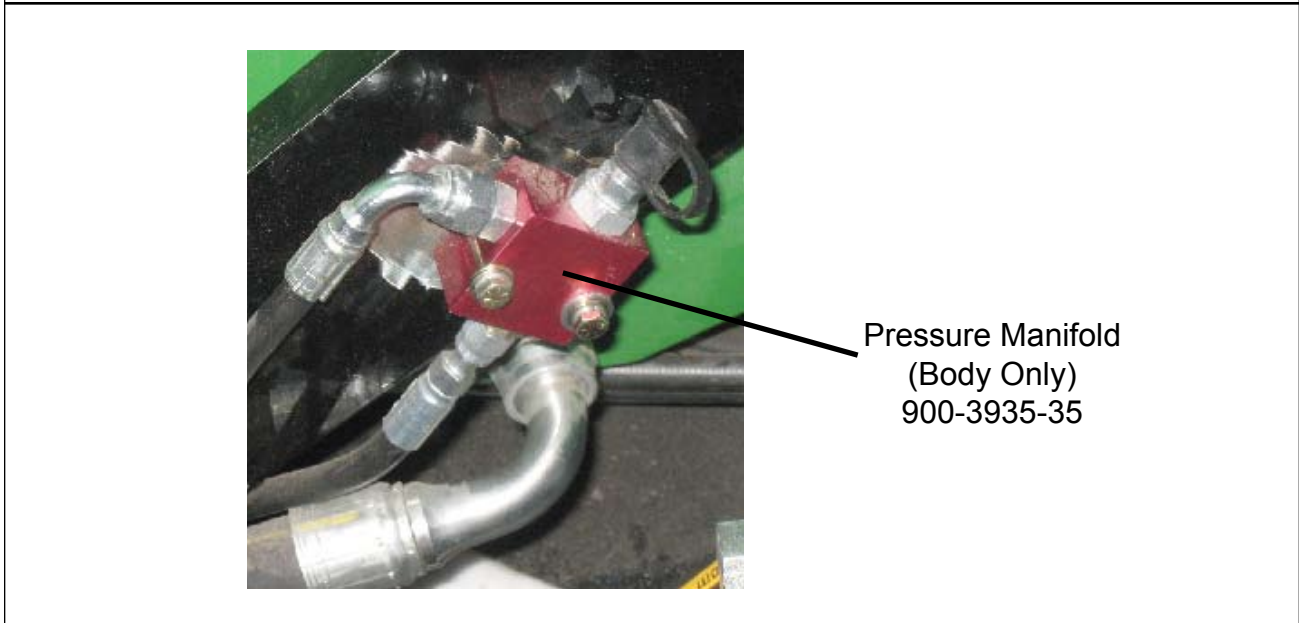
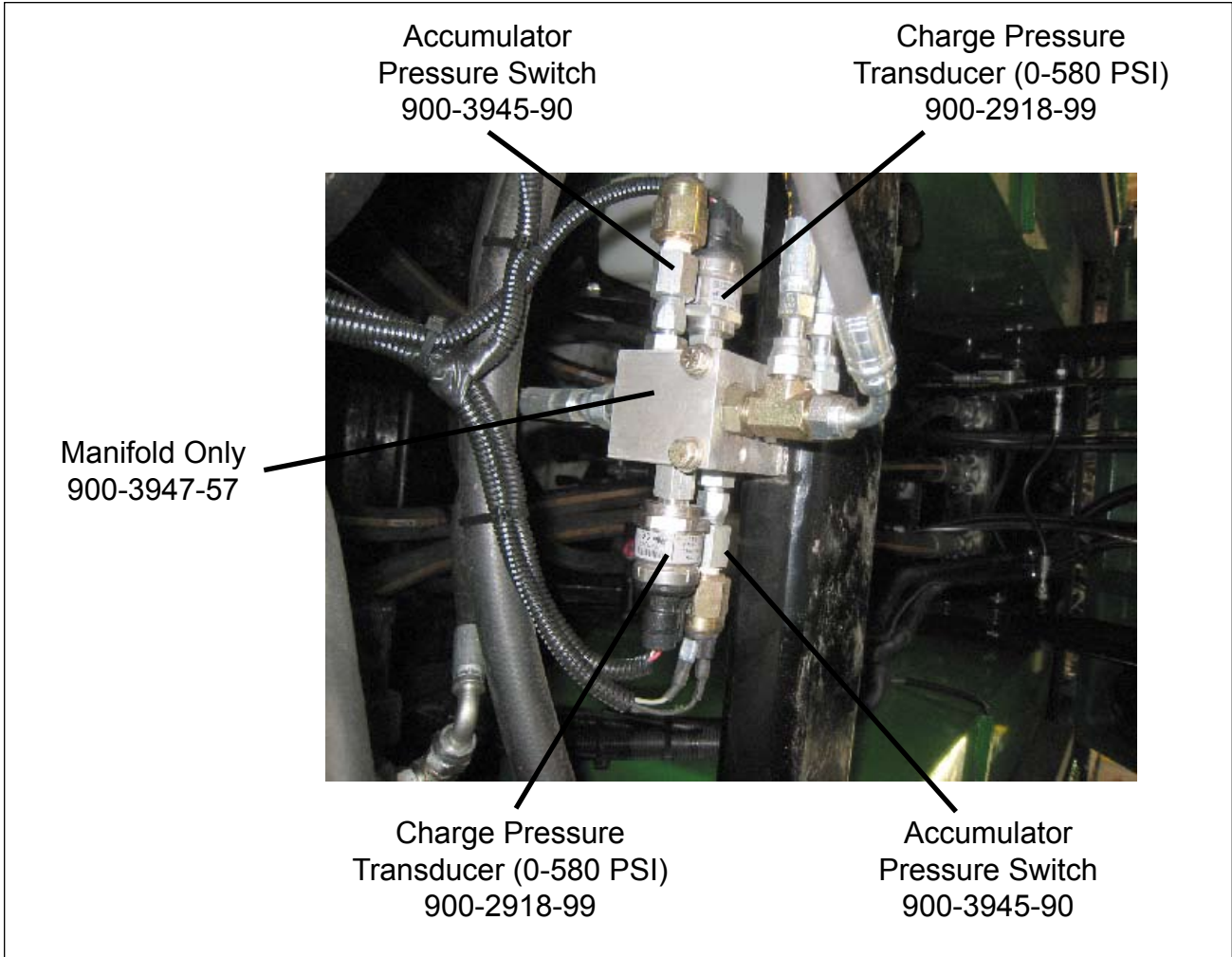

NOTICE Some of the hydraulic components are listed in other component sections.

NOTICE Parts may not be exactly as shown.

