



# BRUSH BANDIT

**BUILT WITH QUALITY  
AND DESIGN FIRST**

## **ATTENTION:**

Depending on what replacement parts you are ordering, we will need the following information:

### **CHIPPER COMPONENTS**

Serial Number  
Model Number of Chipper

### **ENGINE COMPONENTS**

Brand  
Engine Serial Number  
Engine Spec. Number

### **CLUTCH COMPONENTS**

Brand  
Serial Number  
Assembly of Clutch

## **WHOLE TREE CHIPPER MODELS 1900/2400 OPERATING & PARTS MANUAL**

Model No: \_\_\_\_\_

Serial No: \_\_\_\_\_

DEALER:

Name: \_\_\_\_\_

Address: \_\_\_\_\_

City/State: \_\_\_\_\_

Phone No: \_\_\_\_\_

Delivery Date: \_\_\_\_\_

Engine Make: \_\_\_\_\_

Serial No: \_\_\_\_\_

Clutch Make: \_\_\_\_\_

Model: \_\_\_\_\_ S/N \_\_\_\_\_



Copyright 1/06

MANUFACTURED BY  
**BANDIT INDUSTRIES, INC.**

6750 Millbrook Road

REMUS, MICHIGAN, USA 49340

PHONE: (800) 952-0178 IN USA

PHONE: (989) 561-2270 OR 561-2272

FAX: (989) 561-2273 ~ SALES DEPT.

FAX: (989) 561-2962 ~ PARTS/SERVICE

E-MAIL: [www.banditchippers.com](http://www.banditchippers.com)

# CALIFORNIA PROPOSITION 65

## **WARNING**

## **ADVERTENCIA**

Breathing diesel engine exhaust exposes you to chemicals known to the State of California to cause cancer and birth defects or other reproductive harm.

- Always start and operate the engine in a well-ventilated area.
- If in an enclosed area, vent the exhaust to the outside.
- Do not modify or tamper with the exhaust system.
- Do not idle the engine except as necessary.

For more information go to:  
[www.P65warnings.ca.gov/diesel](http://www.P65warnings.ca.gov/diesel)

Respirar gases de escape de motores diesel le expone a químicos conocidos por el estado de California como causales de cáncer y defectos congénitos u otros daños reproductivos.

- Siempre encienda y opere el motor en áreas bien ventiladas.
- Si está en un área cerrada, ventile escape hacia el exterior.
- No modifique ni altere el sistema de escape.
- No deje el motor en ralentí a no ser que sea necesario.

Para mayor información visite:  
[www.P65warnings.ca.gov/diesel](http://www.P65warnings.ca.gov/diesel)

SPW-46 8/18

## **WARNING**

## **ADVERTENCIA**

**Cancer and  
Reproductive  
Harm**

**Cáncer y daño  
reproductivo**

[www.P65warnings.ca.gov](http://www.P65warnings.ca.gov)

SPW-47 8/18

IT IS VERY IMPORTANT THAT THIS FORM IS FILLED OUT COMPLETELY & ACCURATELY. IF WE CANNOT READ THE PURCHASER'S INFORMATION OR IT IS INCORRECT, OUR CUSTOMER LIST WILL NOT BE ACCURATE.

**IMPORTANT - THIS FORM MUST BE RETURNED TO THE CUSTOMER DATA DEPARTMENT WITHIN TEN (10) DAYS IN ORDER TO VALIDATE WARRANTY**

**Customer Data Department  
6750 Millbrook Road  
Remus, MI, USA 49340  
Phone: (800) 952-0178 in USA  
Phone: (989) 561-2270  
Fax: (989) 561-2273  
E-mail: www.banditchippers.com**

**WARRANTY VALIDATION FORM  
(WHOLE TREE & LOADER FED CHIPPER)**

**PURCHASER / OWNER INFORMATION:**

Company Name \_\_\_\_\_ Contact Name \_\_\_\_\_  
 Mailing/Street Address \_\_\_\_\_ City \_\_\_\_\_  
 State \_\_\_\_\_ Zip Code \_\_\_\_\_ Country \_\_\_\_\_ Telephone Number ( \_\_\_\_ ) \_\_\_\_\_  
 E-mail \_\_\_\_\_ Machine Model No. \_\_\_\_\_ Date Put Into Service \_\_\_\_\_  
 Machine Serial No. \_\_\_\_\_ Machine Work Order No. \_\_\_\_\_ Machine Hours \_\_\_\_\_  
 Engine Make \_\_\_\_\_ Engine Serial No. \_\_\_\_\_ Machine Color \_\_\_\_\_

**DEALER / SELLER INFORMATION:**

Dealer/Seller Name \_\_\_\_\_ Contact Name \_\_\_\_\_  
 Mailing/Street Address \_\_\_\_\_ City \_\_\_\_\_  
 State \_\_\_\_\_ Zip Code \_\_\_\_\_ Country \_\_\_\_\_ Telephone Number ( \_\_\_\_ ) \_\_\_\_\_

1. \_\_\_\_\_ Customer has been instructed and understands operation and all safety aspects of operating the equipment.
2. \_\_\_\_\_ Customer has been instructed and understands that everyone within 100 feet (30 m) of machine must wear personal safety equipment (i.e. hard hat, face shield, safety glasses, gloves, ear protection, etc.)
3. \_\_\_\_\_ Customer has been instructed and understands equipment maintenance schedules, procedures, and that it is their responsibility to perform maintenance that includes periodic relief valve adjustments, retightening all fasteners as needed, periodic cleaning of flow divider, clutch and belt adjustments, etc.
4. \_\_\_\_\_ Customer has been advised and understands not to reach into the infeed hopper with hands or feet. The machine operators must always be located within easy reach of all feed control and shut down devices.
5. \_\_\_\_\_ Customer understands that this machine is designed to be "loader" fed and is to follow all feeding instructions in the manual. The customer understands that under no circumstances should the operator hand feed these machines or use anything other than a mechanical device, knuckle boom loader, or the machines loader to feed these machines.
6. \_\_\_\_\_ Customer understands the purpose of and how to operate any safety devices or guards and to never attempt to override any safety devices or guards.
7. \_\_\_\_\_ Customer has been instructed and understands to always remove the ignition key and completely disconnect battery from cables, wait for the chipper disc/drum to come to a complete stop, and to install the disc/drum lock before performing any type of maintenance on the machine. Allow all the time necessary for the disc/drum to come to a complete stop before opening the disc/drum housing or starting any maintenance or service procedures. Customer has been shown and understands the purpose of the beltshield inspection hole and to not attempt any maintenance until belts are visually confirmed to have come to a complete stop.
8. \_\_\_\_\_ Customer has been instructed and understands: To Not operate this machine without the factory approved hood pin assembly in place and padlocked. To Not operate this machine with any type of make shift hood pin. To Not operate this machine under any circumstances with the chipper hood open or unsecured.
9. \_\_\_\_\_ Customer has reviewed and understands limited warranty, and all written and visual instructions.
10. \_\_\_\_\_ Customer has received, been advised, and understands the manuals, and the Safety/Service video supplied with the chipper. A video is supplied for equipment models as available.
11. \_\_\_\_\_ All Danger, Warning and Operational decals are properly displayed on equipment and fully understood by customer.
12. \_\_\_\_\_ Customer has been instructed, understands, and agrees that all potential operators must: See the supplied video, be instructed on all the Danger, Warning and Operational decals, read the manual and follow the procedures.

**I have inspected this equipment and find it in correct working condition. To the best of my knowledge, the customer and his/her personnel are aware of, and agree to the above procedures.**

Signed: \_\_\_\_\_ Date: \_\_\_\_\_  
(Dealer Representative)

**The equipment has been thoroughly checked by the above named dealer representative, and I am satisfied with his/her instructions. I have also read, understand, and agree to reverse side of page.**

Signed: \_\_\_\_\_ Date: \_\_\_\_\_  
(Customer)

**TO BE RETURNED AFTER THIRTY (30) DAYS OF OPERATION**

Please return to: Customer Data Department  
6750 Millbrook Road  
Remus, MI 49340

**PH: (800) 952-0178 in USA**  
**PH: (989) 561-2270**  
**FAX: (989) 561-2273**  
**E-MAIL: www.banditchippers.com**

**DATE PURCHASED:** \_\_\_\_\_

**MODEL:** \_\_\_\_\_

**SERIAL NUMBER:** \_\_\_\_\_

**DEALER NAME:** \_\_\_\_\_

**EQUIPMENT QUALITY REPORT**

All of the employees that build your equipment strive to manufacturer the **very best quality** product on the market. We would appreciate your efforts in letting us know how we are doing.

We would like you to operate your machine for thirty (30) days and then fill out this questionnaire and mail it to us. This will help us to keep producing a good product and improving our products through your recommendations.

- 1. Did your machine perform to your expectations? \_\_\_\_\_
- 2. Was the machine delivered on schedule? \_\_\_\_\_
- 3. Was the paint color and finish to your satisfaction? \_\_\_\_\_
- 4. Was machine equipment as ordered? \_\_\_\_\_
- 5. Did all welds appear to be of high quality? \_\_\_\_\_
- 6. Was the overall machine to your liking? \_\_\_\_\_
- 7. What problems have you experienced? \_\_\_\_\_
- 8. Have any components regularly loosened that caused problems? \_\_\_\_\_
- 9. Does the hydraulic system seem to have adequate power for feeding wood into the machine? \_\_\_\_\_
- 10. Is the machine manufactured to accommodate service in an adequate manner? If not, please explain:  
\_\_\_\_\_  
\_\_\_\_\_
- 11. General comments and/or suggestions: \_\_\_\_\_  
\_\_\_\_\_  
\_\_\_\_\_
- 12. Would you like to be contacted concerning more of our equipment? \_\_\_\_\_

**YOUR COMPANY:** \_\_\_\_\_  
**NAME:** \_\_\_\_\_  
**ADDRESS:** \_\_\_\_\_  
**CITY:** \_\_\_\_\_  
**STATE & ZIP:** \_\_\_\_\_  
**PHONE:** ( \_\_\_\_\_ ) \_\_\_\_\_  
**E-MAIL:** \_\_\_\_\_



# TABLE OF CONTENTS

	PAGES
INTRODUCTION & WARRANTY .....	2
SERIAL NUMBER LOCATIONS .....	6
SAFETY PROCEDURES .....	8
EQUIPMENT SPECIFICATIONS .....	14
DECALS .....	16
AUTOFEED OPTIONS .....	26
CONTROLS .....	28
TRANSPORTATION PROCEDURES .....	33
MAINTENANCE .....	34
HYDRAULIC SECTION .....	48
CHIPPER SECTION .....	61
LUBRICATION & COOLANT .....	65
ELECTRICAL SCHEMATIC .....	66
REPLACEMENT PARTS SECTION .....	67
INFEED HOPPER COMPONENTS .....	68
CHIPPER COMPONENTS .....	70
KNIFE COMPONENTS .....	72
ANVIL COMPONENTS .....	73
SIDE FEEDWHEEL COMPONENTS .....	74
DISCHARGE COMPONENTS .....	75
LOADER COMPONENTS .....	76
PLANETARY SPEED REDUCER COMPONENTS .....	78
GRAPPLE COMPONENTS .....	80
FRAME COMPONENTS .....	82
AIR BRAKE COMPONENTS .....	84
CAB COMPONENTS .....	85
FUEL TANK COMPONENTS .....	86
HYDRAULIC TANK COMPONENTS .....	87
HYDRAULIC COMPONENTS .....	88
BEARING BLOCK COMPONENTS .....	94
REMOTE CONTROL COMPONENTS .....	95
SERVICE RECORD .....	96

NOTE- ANY PART, PORTION, DESIGN, NUMBER, SPECIFICATION, AND/OR DIMENSION IN THIS MANUAL IS SUBJECT TO CHANGE WITHOUT NOTICE BY THE MANUFACTURER.

# INTRODUCTION

The purpose of this manual is to provide the user with specifications and procedures for the operation, maintenance and repair of this BANDIT product. As with any piece of equipment, safety should always be a constant thought while the machine is being operated, serviced or stored. In order to highlight this consideration, the material which addresses safety is preceded by the following signal words:

Signal Word	Likelihood of Occurrence	Degree of Potential Injury or Damage
 <b>DANGER</b>	Will occur if warning is ignored	Severe
 <b>WARNING</b>	Can occur if warning is ignored	Severe
 <b>CAUTION</b>	Will or can occur if warning is ignored	Minor to Severe
<b>NOTICE</b>	Important, but not hazard related	Minor

The equipment is designed and manufactured in accordance with the latest product industry standards. This alone does not prevent injury. It is the operator's responsibility to use good judgement and follow the warnings and instructions as indicated in this manual.

### **WARNING**

Improper use of the product can result in severe personal injury. Personnel using the equipment must be qualified, trained and familiar with the operating procedures as defined in this manual, prior to operating the product.

### **WARNING**

It is the responsibility of the owner or employer to insure that the operator is trained and practices safe operation while using and servicing the machine. It is also the owner's responsibility to provide and follow a regularly scheduled preventative maintenance and repair program on the product, using only factory approved replacement parts. Any unapproved repairs or modifications may not only damage the machine and its performance, but could result in severe personal injury. Unapproved repairs or modifications will void warranty and eliminate manufacturer of any liability claims. Consult the equipment manufacturer!!!

Each machine is shipped with a manual, a customer's check sheet on the product, and any available parts & service manuals on component parts not produced by this manufacturer. Additional copies of these manuals and check sheets can be purchased from the manufacturer, or through the dealer. Engine parts, service and maintenance manuals **MUST** be purchased through the engine manufacturer or their dealer.

**NOTE** - The producer of this Bandit product reserves the right to make any modifications or revisions to the design or specifications of its machine without advance notice. The producer also reserves the right to change machine and part prices as needed without advance notice.

# Bandit



# TYPICAL CHIPPER SERIAL NUMBER LOCATIONS FOR TRAILERIZED MACHINES



1. Front bearing pad
2. Top of frame behind stabilizer

**NOTE:** The engine information is located on the engine block. The clutch information is located on the clutch plate.

# TYPICAL CHIPPER SERIAL NUMBER LOCATIONS FOR TRACK MACHINES



1. Front bearing pad
2. Top of frame inside brush guard

**NOTE:** The engine information is located on the engine block. The clutch information is located on the clutch plate.

# SAFETY PROCEDURES

## **⚠ DANGER**

The words **⚠ Danger**, **⚠ Warning**, **⚠ Caution**, and **Notice** are used on the safety decals and throughout this manual, to make you aware of the safety procedures. These procedures are very important, read and obey them.

### **YOUR SAFETY IS VERY IMPORTANT TO US!**

This machine is equipped with safety decals, guards and designs for your protection.

Don't ever take the machine for granted, always be cautious and careful when operating your equipment.

Read and follow all the instructions in your manual thoroughly. Your safety is dependent on your knowledge of how to operate and maintain this machine. You may obtain additional copies of this manual from your Bandit Dealer.

Before operating machine, you must have all potential operators; read and understand manuals and decals, watch video and follow the recommendations.

Regardless of how hard a manufacturer tries to produce a safe machine, accidents still happen. Normally accidents are caused by people making mistakes. They do not read the manual, they ignore warning decals or do not use lockouts provided for their safety. This normally happens after the person has become accustomed to the machinery. In the initial start up and operation of the machinery, they are cautious, they are very careful because they do not understand the machine.

This equipment is intended for use by personnel who are experienced with similar equipment. Always operate safely. It is also recommended that someone else is present while operating or servicing in case an accident should occur. Never operate any machine while under the influence of drugs or alcohol.

Keep children, bystanders and animals clear of working area. Never operate equipment that is in need of repair or adjustment.

## **⚠ DANGER**

Before starting the machine, take a minute to check a few things. The machine should be in an area restricted from people passing by. This area around the machine must be free of all objects that can obstruct your movement when working with the machine. The machine should be checked for loose tools or foreign objects, especially in the infeed hopper area. All tools not in use should be secured in a tool box.

## **⚠ WARNING**

Operators **must** at all times be located within easy reach of all feed control and shut-off devices when the unit is running.

## **⚠ DANGER**

Torn or loose clothing is more likely to get caught in moving machinery parts or tree branches. Keep such items as long hair, shirt sleeves, and shirt tails properly contained. Avoid wearing necklaces, rings, watches, and especially neckties while operating this machinery. Make sure the machine is in excellent condition, and all the guards are in place, tight and secure.

Wear all personal protection equipment and follow all safety standards per ANSI and OSHA instructions. Examples of equipment: hard hat, safety glasses, gloves, ear protection, etc. Do not wear gauntlet or secured fit gloves. Always keep a fully charged fire extinguisher with the machine while operating or servicing the machine.

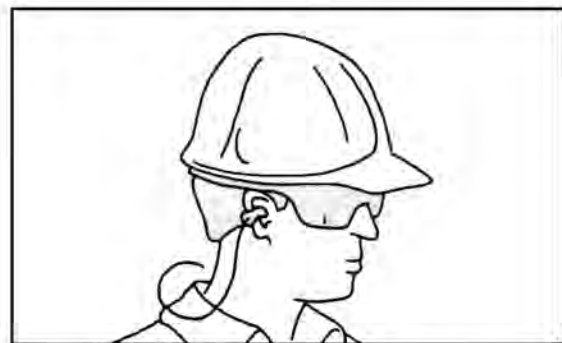

# SAFETY PROCEDURES

## DANGER

Always block the tires and the machine tongue whenever the machine is unhooked for operation. DO NOT rely on the hydraulic stabilizers. With the bouncing and rocking, the stabilizer cylinders may have a tendency to leak off allowing the machine to drop slowly down. Do not depend on them for stability. Install secure blocking as needed.

## DANGER

Pay attention to the direction of the discharge chute before chipping. Never stand in front of the chipper discharge chute. Never direct the chute towards anyone or anything that could cause an accident or problems. Always stop chipping and warn anyone that comes near the discharge area. Failure to do this could result in severe injury. Wood chips flying out of the discharge chute can be very dangerous!

## WARNING

It is very important after you have operated a new machine for approximately an hour to shut down the machine and recheck all nuts and bolts. It is normal for bolts to loosen once on a new piece of machinery. If you tighten them now, there is a good possibility they won't loosen again. Certain bolts should be checked periodically such as anvil and knife bolts, etc. for torque and fit.

Most of the nuts used on the machine are self locking. After a nut has been removed five times, it should be replaced to insure proper tightness. This is especially critical on the chipper knife lock nuts!

After the engine is started, let the chipper disc/drum turn at the lowest RPM's possible. Listen for any type of noise that is foreign. Any steel on steel noise is foreign. If you hear a noise, stop the engine, find the problem and fix it.

## DANGER

The knives must be securely fastened and torqued in position. If one comes loose or breaks during operation, someone or something may get injured.

## DANGER

Chipper knives are sharp and can be dangerous. It is always necessary for your protection to be extra careful and wear leather gloves when handling knives.

## DANGER

Never feed any materials that might contain wires, stones, nails, or other metal objects which may damage the knives and become dangerous projectiles.

## DANGER

Never reach into the infeed hopper area of the machine. There is never any reason to. The feedwheel(s) are designed to pull trees and brush of any length into the machine. Pulling a hand, arm, foot or entire body through the machine is much easier than pulling a tree. Do not think you will be able to pull yourself free of the feedwheel(s), they will not let go. There is absolutely no reason to work inside of the infeed hopper. If the feedwheel(s) become tangled or clogged, stop the machine and wait several minutes before cleaning them out. If there are short pieces, or leaves and twigs, just leave them until feeding longer pieces. The longer pieces will take them on into the machine.

DO NOT use any body parts or any steel devices inside the infeed hopper area.

If there is larger diameter wood, try to feed it with smaller diameter wood. Start a small diameter limb which will partially open the feedwheel(s). Once the feedwheel(s) are partially open it is much easier to insert the larger diameter wood.

When feeding larger diameter wood, listen for the engine to possibly lug down. If it starts lugging down stop the feedwheel(s) by stopping the feed system, and let the engine recover to full speed. If the machine is equipped with Autofeed and is functioning properly, the feed system will automatically stop let the engine recover. This will help stop the machine from plugging the discharge chute.

## DANGER

DO NOT attempt to hand feed this machine. DO NOT operate the loader arm or chipper when anyone is standing or working in front of the chipper infeed opening. Failure to do this could result in serious injury or death.

## CALIFORNIA

### Proposition 65 Warning

Diesel engine exhaust and some of its constituents are known to the State of California to cause cancer, birth defects, and other reproductive harm.

# Bandit

# SAFETY PROCEDURES

**⚠ DANGER**

If the machine is equipped with a hydraulically operated hood. The engine must be running in order to open and close the chipper hood. Before opening hood you **MUST** make sure the chipper disc/drum has come to a complete stop and the disc/drum lock pin has been installed. Under no circumstance should the hood ever be open or opened with the disc/drum moving.

**⚠ DANGER**

DO NOT slam the chipper hood to the open position. This will cause damage to the hinge. If your hinge has become damaged by slamming the hood to the open position, Replace The Hinge Immediately! If the hinge has become damaged it will cause misalignment of the hood, the chipper disc/drum may then hit the hood and cause a serious accident!

**⚠ DANGER**

Do not work inside the mouth of the chipper or around the feedwheel(s), until you have installed the yoke lock pin completely and securely to help keep the top feedwheel in the raised position. Block and chain the top wheel up before doing any work inside throat.

**⚠ DANGER**

Before attempting any type of maintenance disengage clutch, install clutch lock, turn off engine, wait for the chipper disc/drum to come to a complete stop, install the disc/drum lock pin, disconnect battery, and make sure the ignition key is in your possession.

ALWAYS install the disc/drum lock pin to prevent inadvertent rotation. Insert lock pin through lock pin tube on the chipper base.

Simply slide the lock pin into the disc/drum lock tube. This is to insure that the chipper disc/drum cannot be started while you are working inside the machine. If for some reason the chipper disc/drum would start to turn, it would simply hit the lock pin.

**⚠ DANGER**

DO NOT remove the hood pin until the chipper disc/drum has come to a complete stop. The chipper disc/drum will coast for several minutes after the engine is shut down. Always wait at least several minutes.

DO NOT operate this machine without the Hood Pin in place. Do not operate the machine with any type of makeshift hood pin or an improperly installed hood pin! The Hood Pin **MUST** be padlocked.

DO NOT operate the machine with the chipper hood open under any circumstances.

Use Yoke Lock Pin

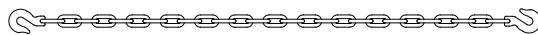
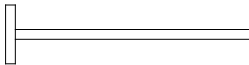

Use Chain

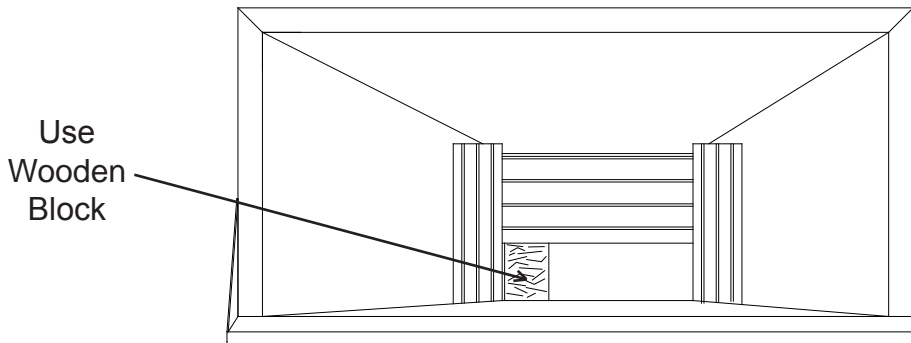

Use Wooden Block

# SAFETY PROCEDURES

## **⚠ DANGER**

Never turn the chipper disc/drum by hand always use a pry bar. This will prevent the person turning the disc/drum from being injured should the disc/drum break loose.

A sight hole in the chipper belt shield has been provided. If chipper belts are moving do not open chipper hood. Do not stick fingers in sight hole.

## **⚠ DANGER**

DO NOT operate this machine indoors! Exhaust fumes can be fatal. Never refuel while the machine is running. Never refuel in the shop or building. Always refuel in a well ventilated area, away from sparks or open flames, DO NOT SMOKE. Extinguish all smoking materials. Wipe up all spilled fuel before restarting the engine. Do not fill above 1/2" from top of tank.

To obtain the most from your machine, for the least amount of cost, it is a good practice to set up and follow a scheduled preventative maintenance program. It will eliminate many possible problems and down time.

## **⚠ WARNING**

Never use jumper cables during freezing temperatures. Tow the machine inside and allow the battery time to warm up. If the machine must be started outside, inspect the battery acid for ice formation. Explosion will occur with a frozen battery. Never use jumper cables in a confined or unventilated area. Battery acid fumes are explosive. Never expose an open flame or spark near the battery.

## **⚠ WARNING**

Before you begin to transport your trailerized machine follow all of the transportation procedures on page 33. Make sure that the tongue has been raised to the proper height and attach the machine securely to the towing vehicle. Once secured to vehicle, locate stabilizer legs and secure them in the transport position. Always hook safety chains to vehicle by crossing them under the tongue allowing enough slack to avoid binding when making turns. Check brakes and highway lights make sure that they are all operating properly. Check that the plug terminal functions match the towing vehicle for proper operation. Make sure that the discharge chute is in the transport cradle and the cradle is locked into position. Be sure to check tire pressure before you begin to transport the machine.

## **NOTICE**

Do not attempt to start the engine or engage the engine PTO (power-take-off) system on this machine if the chipper disc/drum is jammed or frozen in place. If you do, you will damage or ruin the drive belts and/or the PTO which will not be covered under warranty and will cost you down time and money.

**Bandit**

# SAFETY PROCEDURES

## **⚠ DANGER**

Before beginning to operate the loader make sure the loader is unhooked from the transport chains. DO NOT operate this machine or loader arm near power lines. Keep machine and loader arm, when fully extended up and out, at least 10' away from all power lines. Failure to do this could result in serious injury or death.

## **⚠ WARNING**

DO NOT operate this machine unless all hydraulic control devices operate properly. They must function, shift and position smoothly and accurately at all times. Faulty controls can cause personal injury!

## **⚠ WARNING**

It is very important after you have operated a new machine for approximately an hour to shut down the machine and recheck all hydraulic fittings. Retighten as needed.

DO NOT GO NEAR HYDRAULIC LEAKS! High pressure oil easily punctures skin causing serious injury, gangrene, or death. DO NOT use fingers or skin to check for leaks. Lower load or relieve hydraulic pressure before loosening fittings. Use a piece of cardboard to find leaks. Never use your bare hands.

In cold weather situations let your hydraulic system idle for approximately 15 minutes to allow the system to warm up to operating temperature.

## **⚠ DANGER**

DO NOT operate this chipper or loader arm when anyone is performing any type of maintenance to the machine. Before attempting any type of maintenance disengage clutch, install clutch lock, turn off engine, wait for the disc/drum to come to a complete stop, install the disc/drum lock pin, disconnect battery, make sure the ignition key is in your possession, and the loader arm, if equipped, is positioned on the ground. Failure to do this could result in serious injury or death.

## **⚠ DANGER**

Do not work on the machine if the engine is running without the clutch disengaged and the clutch lock installed. A clutch can self engage if either the pilot or throw-out bearing happens to seize to the main output shaft.

There are various types of clutches (PTO's) available for this type of equipment. Make sure to study the original clutch manufacturer's manual that is provided with the machine and follow its instructions for operation, service, and adjustments. Some styles require clutch engagement to be maintained so that it takes a lot of force, others will require very little force, and some are push button, electric, or hydraulic activation. Each different style clutch (PTO) is a very expensive item that will fail if not correctly maintained and adjusted. It will be quite costly if a few minutes are not taken daily, weekly, and monthly to keep the clutch serviced as required.

The operator must take care in the engagement and disengagement of the clutch, engine RPM should always be below 1000 RPM. When the engine has sufficiently warmed up, bump the clutch handle against engagement to start the chipper disc/drum turning. This will have to be repeated until the chipper disc/drum is turning at proper ratio with engine RPM. Then push the handle all the way in gear until it locks into position securely. After engagement raise engine RPM to full throttle. Engaging and disengaging the clutch at high engine RPM will quickly and excessively wear out clutch plates as well as bearings. Refer to clutch manufacturer's manual for proper service and operation.

## **⚠ DANGER**

NEVER sit, stand, lay, climb or ride anywhere on this machine while it is running, operating, or in transit. You will be injured.



# Bandit

# SAFETY PROCEDURES

## IF MACHINE IS EQUIPPED WITH UNDERCARRIAGE TRACK

Machines equipped with undercarriage tracks are shipped with a manual from the track manufacturer. Refer to it for service, operation, and safety information.

**⚠ WARNING**

Do not attempt to operate the track machine on an ascending or descending slope of more than 25° or 46% or a side slope of more than 17° or 30%, it is Dangerous and could be Fatal. This is the maximum slope grade the machine can be operated on if the hydraulics, tracks, and engine are running at maximum performance and the tracks sustain good traction.

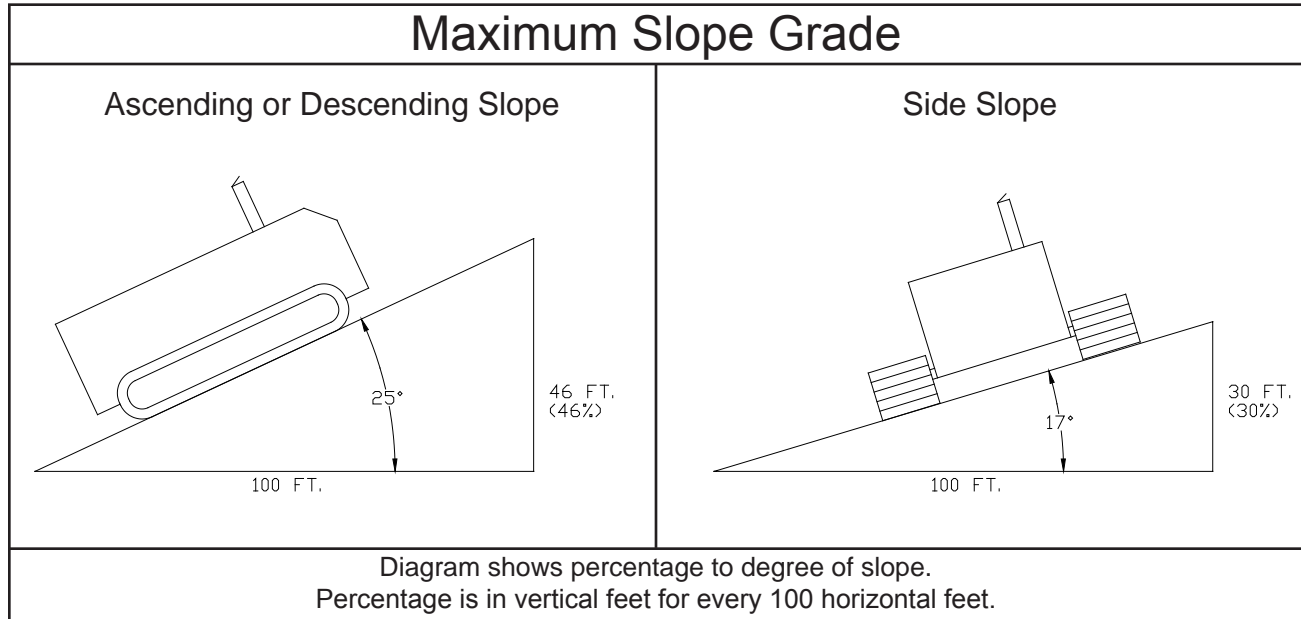

**⚠ WARNING**

Any increase from the specified maximum operating angles may cause loss of lubrication function and damage the engine.

**⚠ DANGER**

The track machine should never be parked on a slope at any time. The machine can coast or creep causing equipment and/or personal injury.

**⚠ DANGER**

Make sure everyone is clear of machine before moving the track machine. Stay clear of tracks when the machine is moving.

**⚠ DANGER**

**DO NOT** entangle feet or hands in undercarriage travel system.

**⚠ DANGER**

Use **EXTREME CAUTION** when traveling over non-level surface! This machine can tip over or tip backwards on non-level surface. You will cause engine damage, machine damage and possible personal injury!

**⚠ DANGER**

**NEVER** sit, stand, lay, climb or ride anywhere on this machine while it is running, operating, or in transit. You will be injured.

**Bandit**

TRAILERIZED EQUIPMENT SPECIFICATIONS



Approximate Dimensions & Weights

(Dimensions & weights will vary depending on optional equipment)

Approx. Weight:	Model 1900:	30,000 to 32,000 lbs.
	Model 1900XL:	26,000 to 28,000 lbs.
	Model 2400:	62,000 to 64,000 lbs.
	Model 2400XL:	N/A

(Approximate weights depending on engine and equipment options.)

Overall Dimension:	Model 1900:	Height: 137",	Length: 320",	Width: 108"
	Model 1900XL:	Height: 137",	Length: 320",	Width: 108"
	Model 2400:	Height: 156",	Length: 370",	Width: 132"
	Model 2400XL:	Height: N/A,	Length: N/A,	Width: N/A

	<u>Model 1900</u>	<u>Model 1900XL</u>	<u>Model 2400</u>	<u>Model 2400XL</u>
Fuel Tank Capacity:	200 Gallons	200 Gallons	340 Gallons	N/A
Hydraulic Tank Capacity:	200 Gallons	65 Gallons	200 Gallons	N/A

(Approximate dimension depending on equipment options.)

# TRACK EQUIPMENT SPECIFICATIONS



## Approximate Dimensions & Weights

(Dimensions & weights will vary depending on optional equipment)

Approx. Weight:	Model 1900 Track:	70,000 to 72,000 lbs.
	Model 2400 Track:	83,000 to 85,000 lbs.

(Approximate weights depending on engine and equipment options.)

Overall Dimension:	Model 1900 Track:	Height: 137",	Length: 273",	Width: 138"
	Model 2400 Track:	Height: 156",	Length: 322",	Width: 138"

	<u>Model 1900 Track</u>	<u>Model 2400 Track</u>
Fuel Tank Capacity:	200 Gallons	340 Gallons
Hydraulic Tank Capacity:	200 Gallons	200 Gallons

(Approximate dimension depending on equipment options.)

# DECAL LOCATIONS - MODEL 1900/2400 TRAILERIZED

Decal locations may vary, these are general locations.

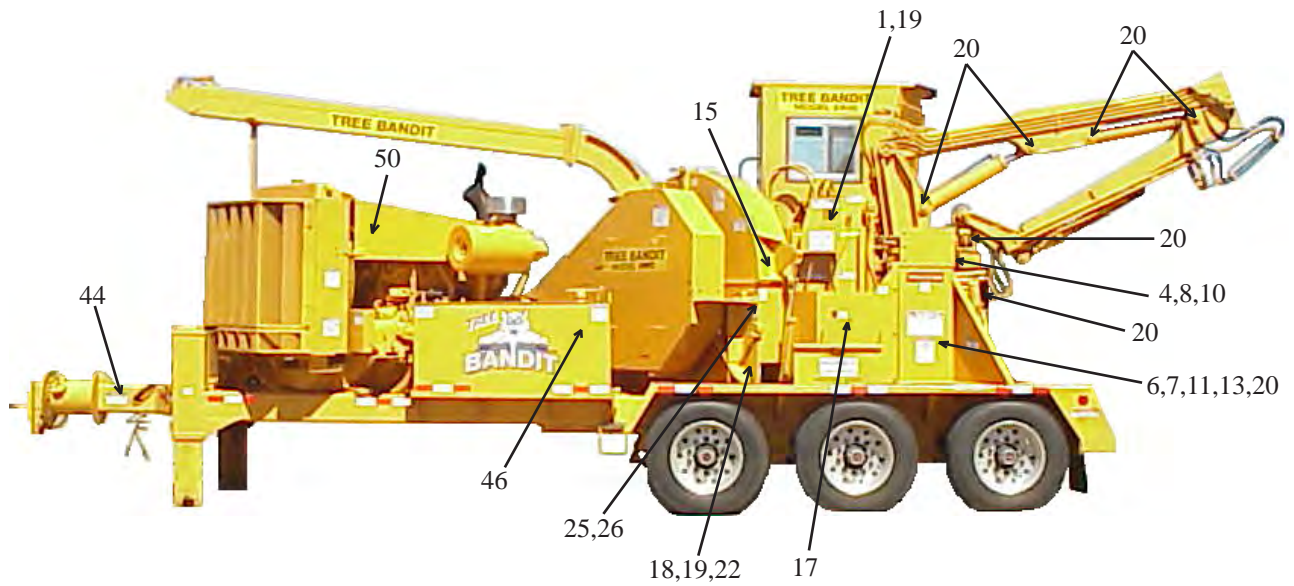
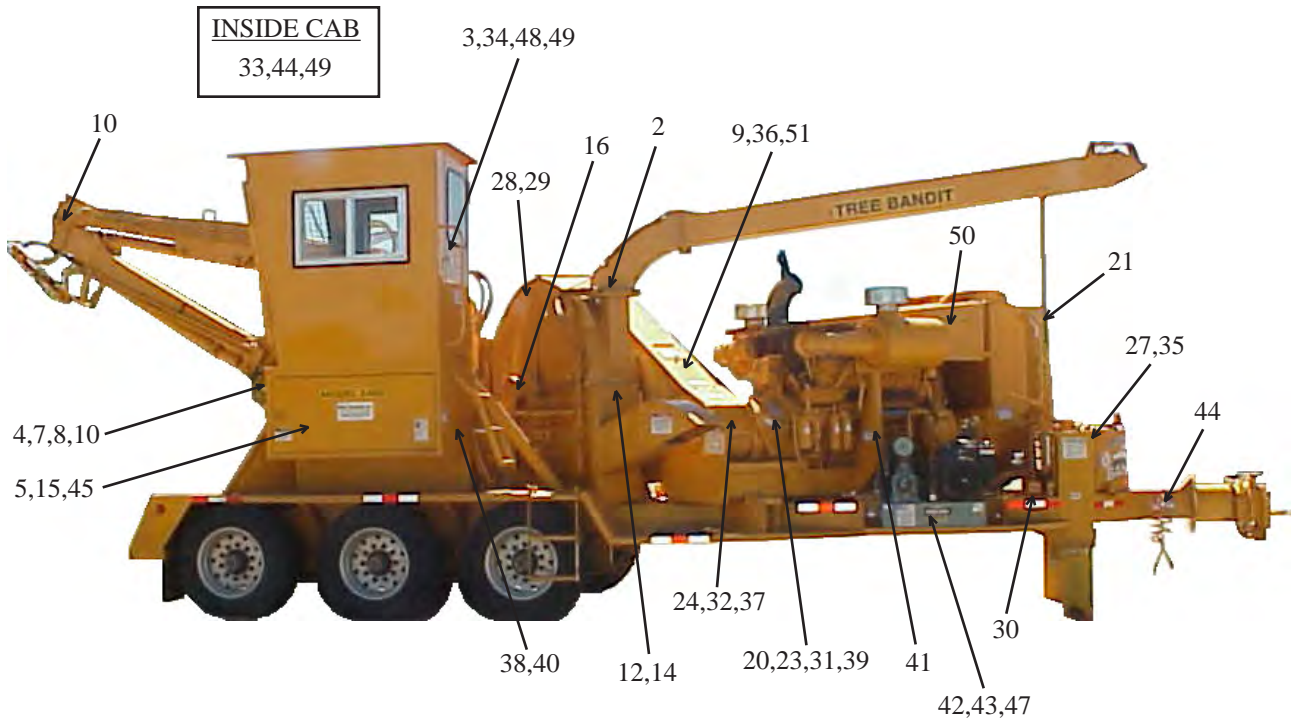

## DECAL LOCATIONS - MODEL 1900/2400 TRAILERIZED

Modifications and/or additions of decals to this list will happen.  
Consult chipper dealer or manufacturer for most current decal package.

LOCATION	NUMBER	DESCRIPTION
1.	D-02	Moving Parts...
2.	D-04	Flying Discharge Material...
3.	D-15	Do Not Operate Loader Arm...
4.	D-16	Do Not Hand Feed...
5.	D-17	Do Not Run Or Operate...
6.	D-18	Never Perform Maintenance...
7.	D-20	Flying Objects Stand Clear...
8.	D-25	Stand Clear - Moving Conveyor
9.	D-28	Do Not Insert Fingers...
10.	D-29	NO Do Not Climb...
11.	D-30	Do Not Sit, Stand, Lay, Climb...
12.	D-32	Do Not Operate This Machine...
13.	D-33	Do Not Work Under...
14.	D-37	Lockout All Energy Sources...
15.	ID-42	Bandit Industries Inc...USA
16.	INST-01	Remove To Check Torque...
17.	INST-02	Yoke Lock Hole
18.	INST-03	Yoke Lock Bar
19.	INST-04	Arrow
20.	INST-12	Grease Daily (Arrow)
21.	INST-18	Transport Brace...
22.	INST-23	Chipper Hood Cylinder... (Model 2400)
23.	INST-43	Clutch Lock
24.	INST-44	California Proposition 65
25.	INST-48	Disc/Drum Lock Tube
26.	INST-49	Disc/Drum Lock Pin
27.	INST-53	Hydraulic Oil...Hydrex XV...
28.	INST-54	Model 2400 Knife Hardware Assembly...
29.	INST-55	Model 1900 Knife Hardware Assembly...
30.	INST-90	Stabilizer Up / Down
31.	INST-92	Air Brake Release
32.	INST-101	Canada Engine Decal
33.	INST-102	Joystick Controls
34.	INST-110	Window Washing Instructions

Note: Some decals are for optional equipment. Decal locations may vary, these are general locations. If any decals become damaged, replace immediately.

# DECAL LOCATIONS - MODEL 1900/2400 TRAILERIZED

Decal locations may vary, these are general locations.

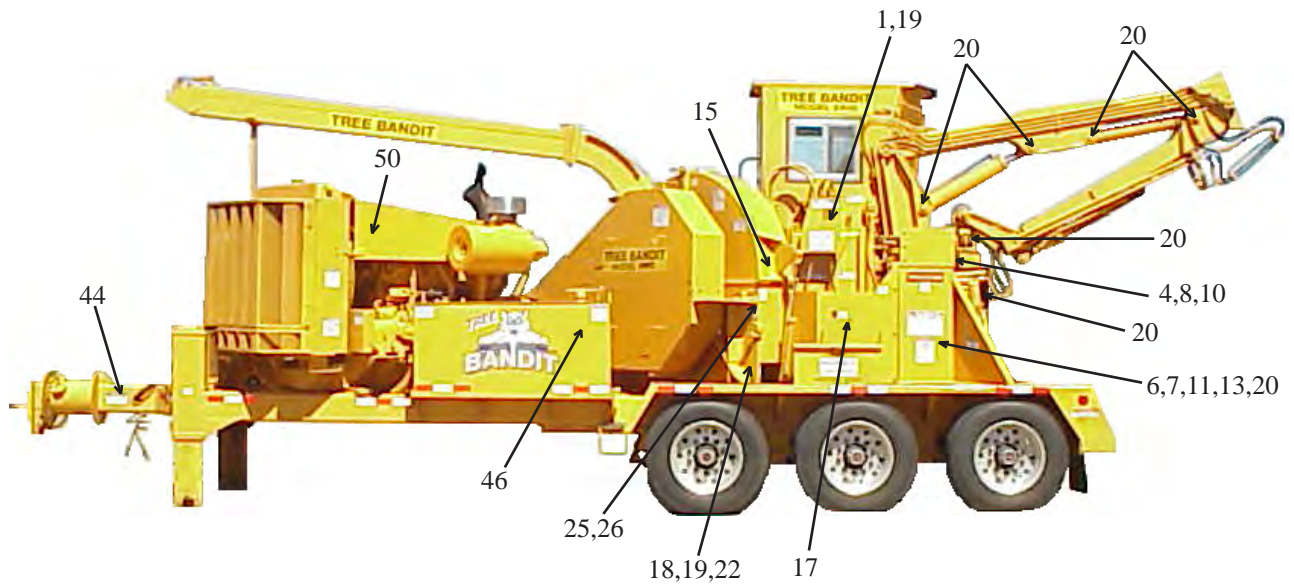
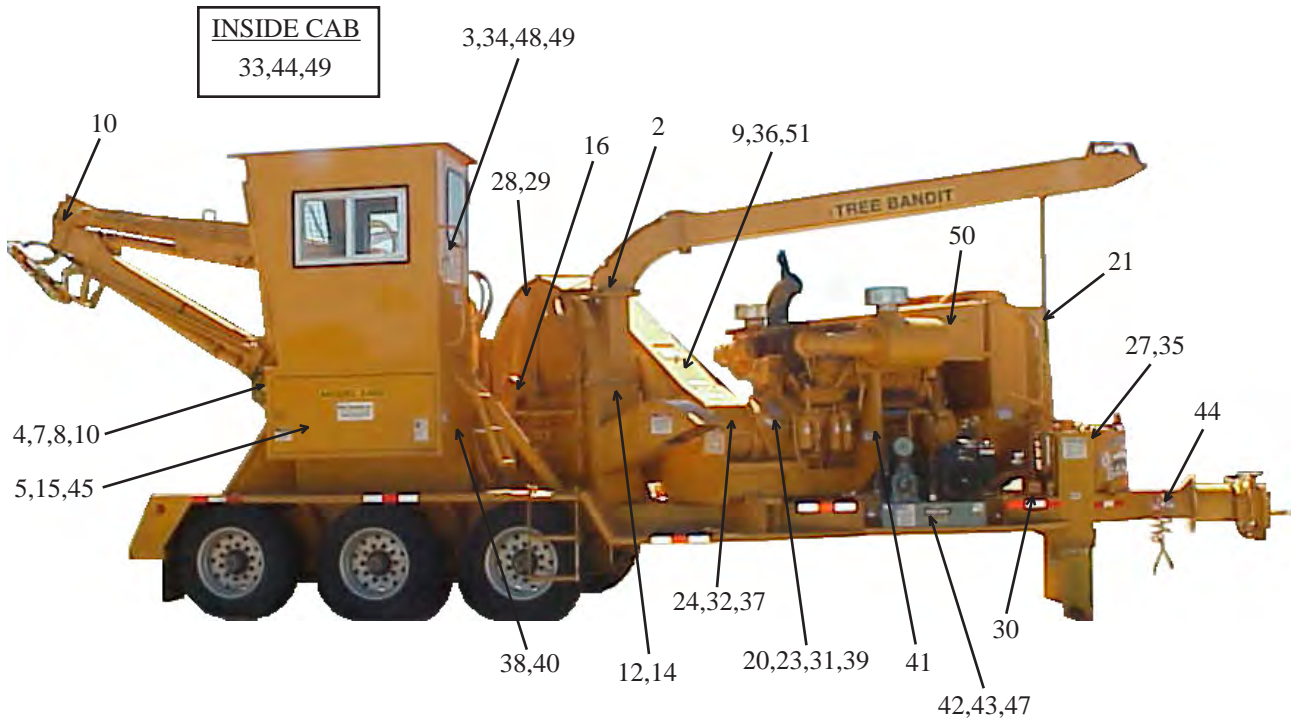

**DECAL LOCATIONS - MODEL 1900/2400 TRAILERIZED**

Modifications and/or additions of decals to this list will happen.  
 Consult chipper dealer or manufacturer for most current decal package.

LOCATION	NUMBER	DESCRIPTION
35.	N-02	Maintain Lubrication...
36.	N-03	Service Required Under Beltshield...
37.	N-05	Frequently Adjust...PTO...
38.	N-06	Decal Maintenance...
39.	N-07	Clutch Operation...
40.	N-08	Patents...
41.	N-14	Do Not Start To Weld...
42.	N-16	24 Volt Circuit...
43.	N-17	Battery Disconnect Switch...
44.	N-20	Maximum Towing Speed 55 MPH
45.	W-01	Do Not Go Near Oil Leaks...
46.	W-02	Diesel Fuel Only...
47.	W-04	Frozen Battery Can Explode...
48.	W-07	Do Not Move Machine...
49.	W-08	Wear Personal Protection...
50.	W-13	Check For Fires, Clean Off Debris...
51.	W-15	Do Not Open This Door...
52.		Bandit Model 1900 Vinyl Decals
53.		Bandit Model 1900XL Vinyl Decals
54.		Bandit Model 2400 Vinyl Decals
55.		Bandit Model 2400XL Vinyl Decals
56.	Optional	Spanish/ English Decals

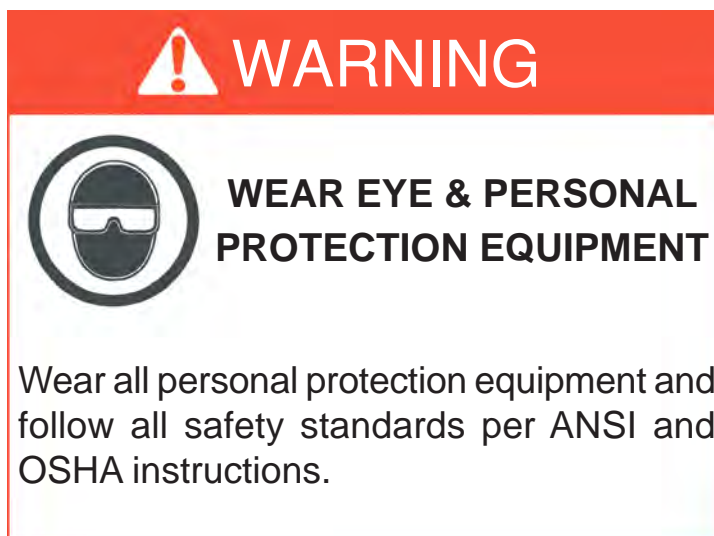

Note: Some decals are for optional equipment. Decal locations may vary, these are general locations. If any decals become damaged, replace immediately.

# DECAL LOCATIONS - MODEL 1900/2400 TRACK

Decal locations may vary, these are general locations.

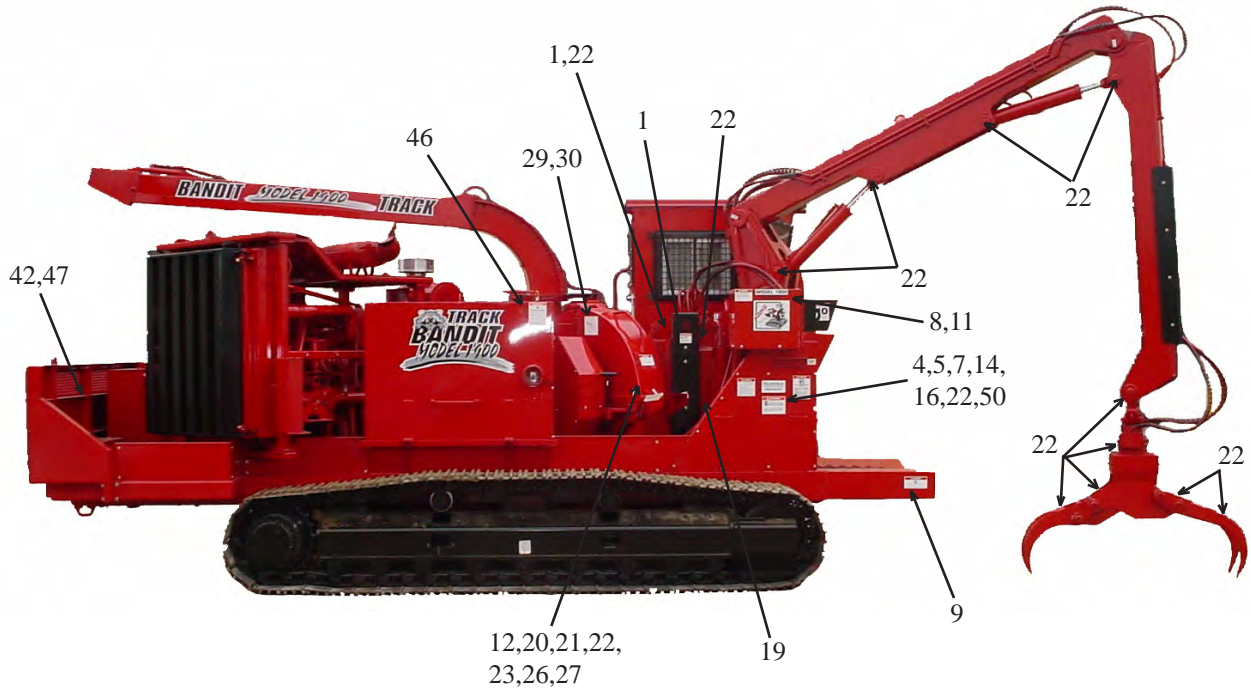
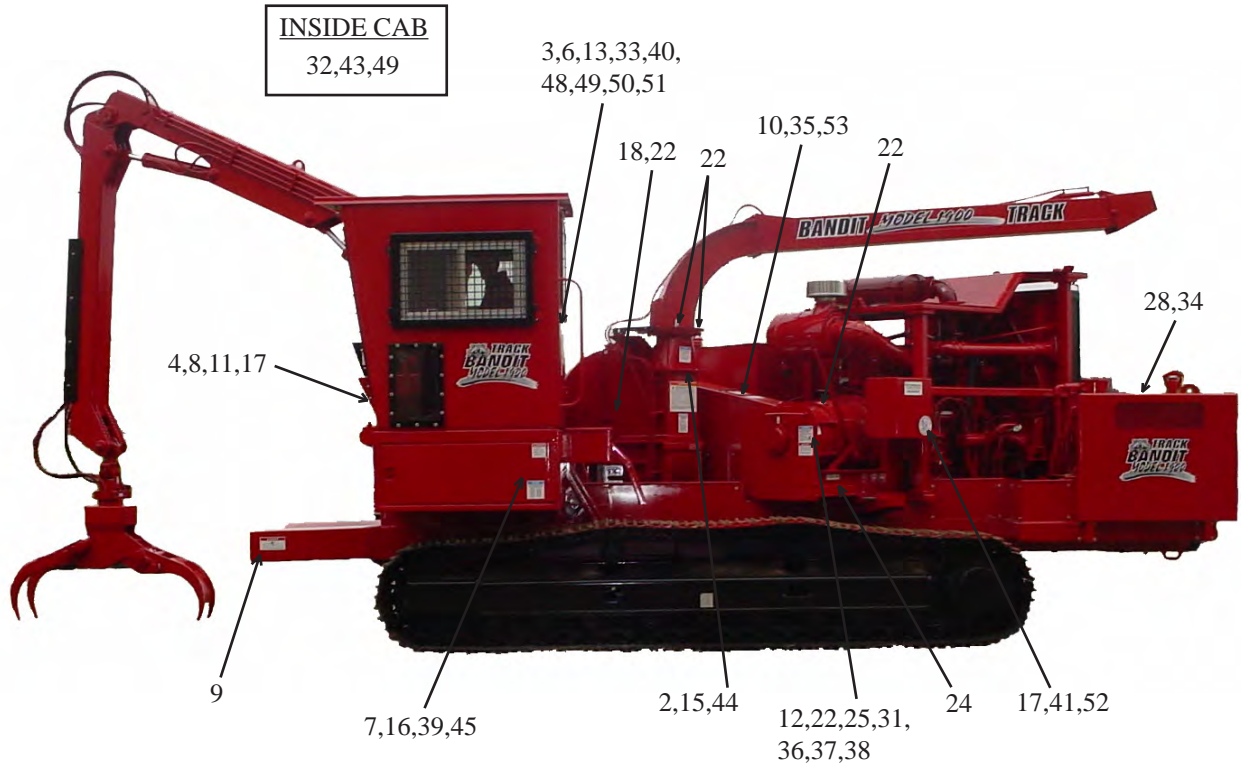

## DECAL LOCATIONS - MODEL 1900/2400 TRACK

Modifications and/or additions of decals to this list will happen.  
Consult chipper dealer or manufacturer for most current decal package.

LOCATION	NUMBER	DESCRIPTION
1.	D-02	Moving Parts...
2.	D-04	Flying Discharge Material...
3.	D-15	Do Not Operate Loader Arm
4.	D-16	Do Not Hand Feed
5.	D-17	Do Not Run Or Operate...
6.	D-18	Never Perform Maintenance...
7.	D-19	...Minimum 10 Feet Away From Tracks...
8.	D-20	Flying Objects - Stand Clear
9.	D-25	Stand Clear - Moving Conveyor
10.	D-28	Do Not Insert Fingers
11.	D-29	NO Do Not Climb...
12.	D-30	Do Not Sit, Stand, Lay, Climb...
13.	D-32	Do Not Operate This Machine...
14.	D-33	Do Not Work Under...
15.	D-37	Lockout All Energy Sources...
16.	D-38	Do Not Entangle Feet...
17.	ID-42	Bandit Industries Inc...USA
18.	INST-01	Remove To Check Torque...
19.	INST-02	Yoke Lock Hole
20.	INST-03	Yoke Lock Bar
21.	INST-04	Arrow
22.	INST-12	Grease Daily (Arrow)
23.	INST-23	Chipper Hood Cylinder... (Model 2400)
24.	INST-43	Clutch Lock
25.	INST-44	California Proposition 65
26.	INST-48	Disc/Drum Lock Tube
27.	INST-49	Disc/Drum Lock Pin
28.	INST-53	Hydraulic Oil...Hydrex XV...
29.	INST-54	Model 2400 Knife Hardware Assembly...
30.	INST-55	Model 1900 Knife Hardware Assembly...
31.	INST-101	Canada Engine Decal
32.	INST-102	Joystick Controls
33.	INST-110	Window Washing Instructions

Note: Some decals are for optional equipment. Decal locations may vary, these are general locations. If any decals become damaged, replace immediately.

# DECAL LOCATIONS - MODEL 1900/2400 TRACK

Decal locations may vary, these are general locations.

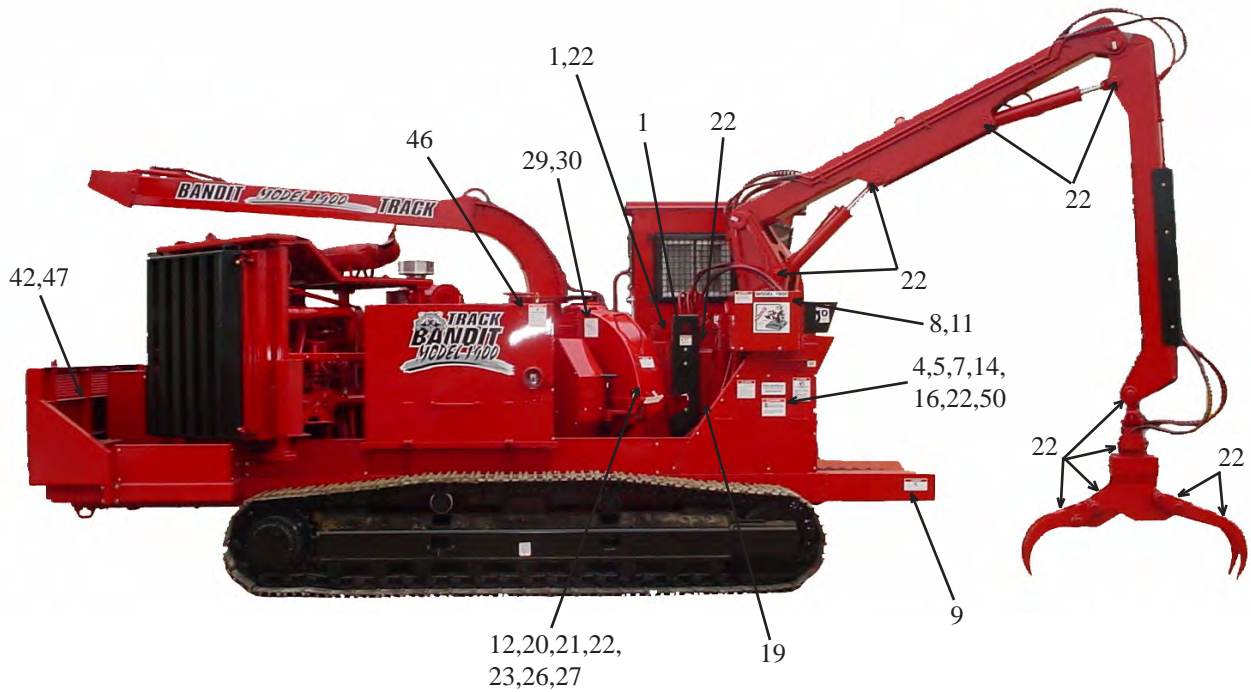
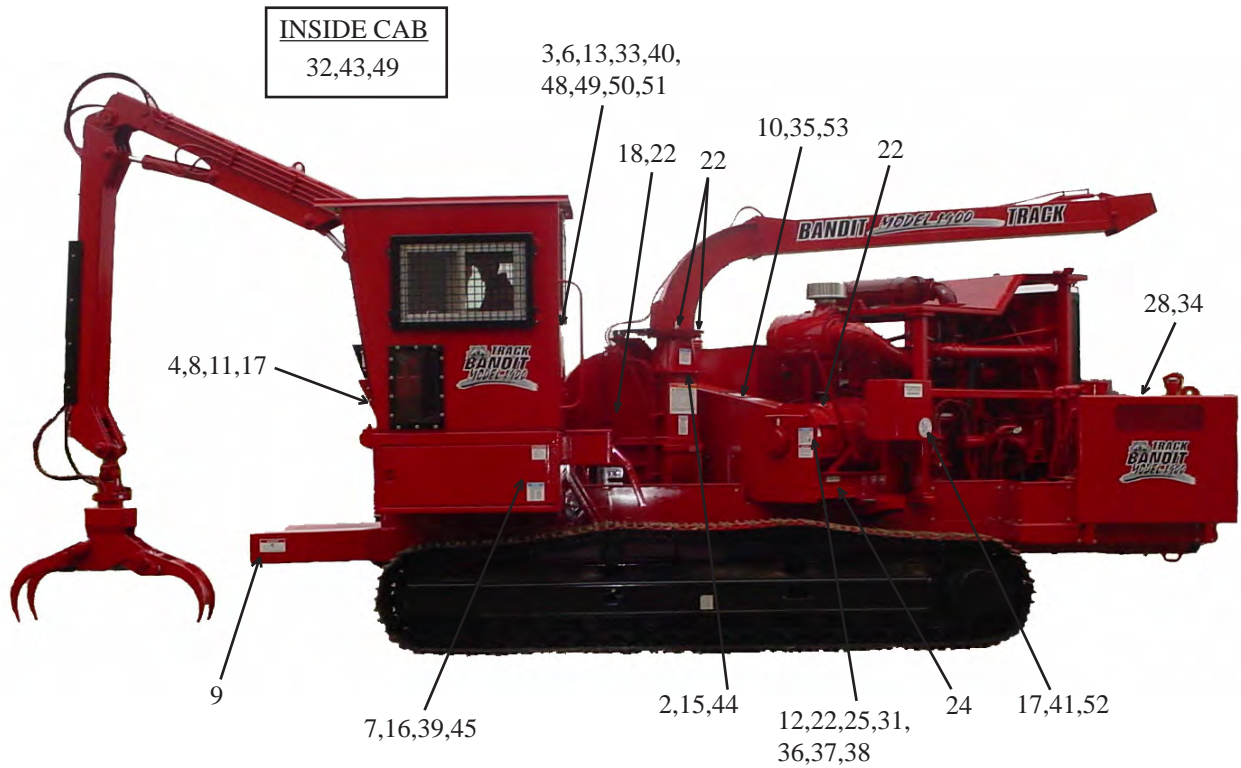

**DECAL LOCATIONS - MODEL 1900/2400 TRACK**

Modifications and/or additions of decals to this list will happen.  
 Consult chipper dealer or manufacturer for most current decal package.

LOCATION	NUMBER	DESCRIPTION
34.	N-02	Maintain Lubrication...
35.	N-03	Service Required Under Beltshield...
36.	N-05	Frequently Adjust...PTO...
37.	N-06	Decal Maintenance...
38.	N-07	Clutch Operation...
39.	N-08	Patents...
40.	N-10	Always Fold Loader...
41.	N-14	Do Not Start To Weld...
42.	N-16	24 Volt Circuit...
43.	N-17	Battery Disconnect Switch...
44.	N-18	Do Not Operate This Machine...
45.	W-01	Do Not Go Near Oil Leaks...
46.	W-02	Diesel Fuel Only...
47.	W-04	Frozen Battery Can Explode...
48.	W-06	Do Not Attempt...Slope Of More Than 17°...
49.	W-07	Do Not Move Machine...
50.	W-08	Wear Personal Protection...
51.	W-11	Do Not Leave Unit Parked On A Slope...
52.	W-13	Check For Fires, Clean Off Debris...
53.	W-15	Do Not Open This Door...
54.		Bandit Model 1900 Track Vinyl Decals
55.		Bandit Model 2400 Track Vinyl Decals
56.	Optional	Spanish/ English Decals



Note: Some decals are for optional equipment. Decal locations may vary, these are general locations. If any decals become damaged, replace immediately.

# DECALS

Decals located on your Bandit equipment contain useful information to assist you in operating your equipment safely. Some of the decals on your machine and their location are shown in this section.

It is very important that all decals remain in place and in good condition on your machine. Please follow the care and instructions given below:

- 1) You should use soap and water to keep your decals clean. Never use mineral spirits or any other abrasive cleaners.
- 2) Replace immediately any missing or damaged decals. The location the decal is going to be applied to must be clean and dry, and at least 40° F (5°C) before applying decal.
- 3) When the need arises to replace a machine component with a decal attached, be sure and replace the decal.
- 4) Replacement decals are available, and can be purchased from the manufacturer or your Bandit Dealer.
- 5) Other language decals may be purchased. Spanish and other foreign language decals are available. Mail translated decals required to Bandit Industries, Inc.

## EXAMPLES: (New Style Decals)

NOTICE

DECAL MAINTENANCE IS THE RESPONSIBILITY OF THE OWNER OF THIS MACHINE. KEEP DECALS LEGIBLE. DECALS (ETC.) ARE AVAILABLE IN OTHER LANGUAGES.

CONTACT: PARTS DEPARTMENT  
6750 MILLBROOK RD.  
REMUS, MI 49340  
PHONE (888) 748-6348

**DANGER**

**DO NOT** insert fingers or amputation could occur.

**DO NOT** perform any maintenance until belts inside this hole have completely stopped moving.

NOTICE

THE CLUTCH HANDLE SHOULD NOT BE ENGAGED OR DISENGAGED AT SPEEDS ABOVE 1000 RPM'S.

DO NOT operate this Clutch/PTO unless proper adjustments and lubrication are maintained per the Clutch/PTO Manufacturer's Manual. Different brands and models require different service and operation procedures. New Clutch/PTO's require more frequent adjustment.

GOOD OPERATORS DON'T WASTE MONEY!

Clutches will fail, glaze over, and burn up from improper adjustment. This will cost the owner of this machine thousands of dollars to repair. A well maintained, correctly adjusted clutch should function properly for years.

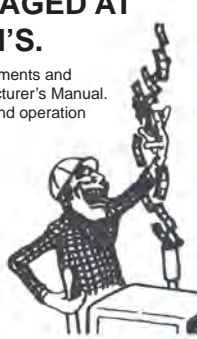

**DANGER**

**DO NOT** sit, stand, lay, climb or ride anywhere on this machine while it is running, operating or in transit.

YOU WILL BE INJURED!

Examples of some previous (old style) decals on Bandit equipment containing safety information. This information is also contained in the current (new style) decals, in the operating manual, and in the operations video.

 **DANGER**

**NEVER** OPEN OR CLOSE THE CHIPPER HOOD WITH THE ENGINE RUNNING OR THE DISC TURNING.

**NEVER** PERFORM ANY TYPE OF MAINTENANCE ON THIS MACHINE WITHOUT SHUTTING THE ENGINE OFF AND REMOVING THE ENGINE KEY. THE CUTTERWHEEL WILL COAST FOR SEVERAL MINUTES AFTER THE ENGINE IS SHUT OFF.

**ALWAYS** WAIT UNTIL THE DISC HAS COME TO A COMPLETE STOP BEFORE OPENING THE CHIPPER HOOD.



 **DANGER**

**YOKE LOCK PIN**



NEVER PERFORM ANY WORK UNDER TOP FEED WHEEL UNTIL THE YOKE LOCK PIN IS SECURELY IN PLACE.

NEVER OPERATE/RUN THE CHIPPER DISC OR FEED WHEELS WITH THE YOKE LOCK PIN HOLDING TOP FEED WHEEL UP.

 **DANGER**

**NEVER**

SIT, STAND OR RIDE AT ANY TIME IN THE INFEED AREA OR ANYWHERE ELSE ON THIS MACHINE - YOU CAN BE SEVERELY INJURED.

 **DANGER**

THIS MACHINE IS NOT DESIGNED TO BE HAND FED. HAND FEEDING IS VERY DANGEROUS!

**DO NOT DO IT!**

 **DANGER**

**DO NOT** OPERATE THIS CHIPPER OR LOADER ARM WHEN ANYONE IS PERFORMING ANY TYPE OF MAINTENANCE TO THE MACHINE. THE ENGINE **MUST** BE SHUT OFF, THE CUTTERWHEEL **MUST** BE COMPLETELY STOPPED BY WAITING A MINIMUM OF 10 MINUTES AND THE LOADER ARM POSITIONED ON THE GROUND. **FAILURE TO DO THIS COULD RESULT IN SERIOUS INJURY OR DEATH.**

# AUTOFEED OPTIONS

## AUTOFEED SYSTEM

Consult the original manufacturer's manual for your chippers  
Autofeed operating and maintenance procedures

When processing material through the chipper, the feed system will automatically stop when the engine drops below a preset RPM point. The engine is constantly being monitored by an adjustable electronic speed switch. The switch can be adjusted so that at a given RPM, an electronic relay system will operate the hydraulic solenoid valves to stop until the engine has recovered speed. The "Autofeed Plus" system will reverse for a set period of time and then stop until the engine has recovered speed. Both autofeed systems will then automatically turn the feed on to resume forward travel.

Due to required components and equipment options a machine may have various types or brands of autofeed systems. Each chipper is shipped with the original manufacturer's manual for the autofeed system it is equipped with.

For the approximate autofeed settings on all optional autofeed systems refer to page 27 of the chipper manual. For part numbers on the hydraulic portion of the autofeed systems refer to pages 92 & 93 of the chipper manual.

Do not power wash the digital tach hour meters. Pressure causes unwarranted damage. **Do not spray tach, this will void warranty.**

### PART NUMBERS FOR AUTOFEED DIGITAL TACH HOUR METERS

L.O.R. MFG.  
 Part Number: 900-2906-83

For Service Call  
 1-866-644-8622



# TROUBLE SHOOTING GUIDE

**POSSIBLE CAUSES WHY AUTOFEED DOES NOT WORK OR IS INTERMITTENT:**

- |   |   |
|---|---|
| <ol style="list-style-type: none"> <li>1. Autofeed is not turned on.</li> <li>2. Engine not coming back to full rated RPM.</li> <li>3. Tach not programmed correctly.</li> <li>4. Bad or corroded fuse holder.</li> <li>5. Bad fuse.</li> <li>6. Loose or corroded wire ends.</li> <li>7. Not wired properly.</li> <li>8. Alternator belt loose.</li> </ol> | <ol style="list-style-type: none"> <li>9. Alternator not working.</li> <li>10. Hydraulic valve not working.</li> <li>11. Hydraulic valve stuck in OPEN or CLOSED position.</li> <li>12. Hydraulic coil bad.</li> <li>13. Hydraulic coil not grounded properly.</li> <li>14. Chipper belts loose.</li> <li>15. Clutch slipping, not adjusted correctly.</li> </ol> |
|---|---|

NOTE: Refer to the Completion/Check Sheet, that is shipped with the machine for the correct engine rpm. If needed, contact your local dealer or Bandit Industries.

## APPROXIMATE DIGITAL AUTOFEED SETTINGS (FOR ALL AUTO FEED SYSTEMS - REFERENCE ONLY)

Some Current Engine Types	Maximum RPM	Magnetic Pick-Up PPR	Off RPM	On RPM	Feed Reverse Time
Caterpillar C-12, 457 Hp	2100	113	2050	1500	.3
Caterpillar C-15, 566 Hp	2100	136	2050	1850	.3
Caterpillar C-16, 647 Hp	2100	136	2050	1800	.3
Caterpillar 3412E, 760 Hp	2100	136	2050	1750	.3
Cummins QSK-23, 800 Hp	2100	142	2050	1800	.3
<b>Some Prior Engine Types</b>					
Caterpillar 3412, 650 Hp	2100	136	2050	1750	.3
Caterpillar 3412, 680 Hp	2100	136	2050	1750	.3
Cummins QSK-19, 650 Hp	2100	142	2050	1800	.3

# CONTROLS

## Basic Location Of Cab Controls And Adjustments For Models 1900/2400

- |                               |   |
|-------------------------------|---|
| 1. Autofeed Tach              | 11. Discharge Swivel Switch                     |
| 2. Power View                 | 12. High/Low Speed Switch (Tracks)              |
| 3. Horn Switch                | 13. Function Switch (Loader or Track)           |
| 4. Throttle Switch            | 14. Feedwheel Buttons                           |
| 5. Variable Heat Control      | 15. Loader Swing Foot Pedals (Not Shown)        |
| 6. Heater / Air Conditioning  | 16. Chipper Hood Switch - Mod. 2400 (Not Shown) |
| 7. Fan                        |   |
| 8. Engine Kill Switch         |   |
| 9. Yoke Buttons               |   |
| 10. Horizontal Flipper Switch |   |



---

# CONTROL OPERATING PROCEDURES

**HORN SWITCH (#3):**

The horn switch is located on the gauge panel. To sound the horn push the horn switch in.

**THROTTLE SWITCH (#4):**

The throttle switch is located on the gauge panel. To make the engine throttle up push the throttle switch up. To make the engine throttle down push the throttle switch down.

**ENGINE KILL SWITCH (#8):**

The engine kill switch is located on the gauge panel. To kill the engine push the engine kill switch in.

**YOKE UP / DOWN BUTTONS (#9):**

The yoke up and down buttons are located on top of the left hand joystick. To make the yoke go up push the left button down. To make the yoke go down push the right button down.

**HORIZONTAL FLIPPER SWITCH (#10):**

The horizontal flipper switch is located on the right joystick console. To make the flipper go up push the flipper switch forward. To make the flipper go down push the switch backwards.

**DISCHARGE SWIVEL SWITCH (#11):**

The discharge swivel switch is located on the right joystick console. To make the discharge swivel to the right push the switch right. To make the discharge swivel to the left push the switch left.

**FEEDWHEEL BUTTONS (#14):**

The feedwheel control is located on the buttons on top of the right hand joystick. To make the feedwheels rotate so that they are pulling material into the machine, push the right button down. To turn the feedwheels off, push the right button again. To make the feedwheels rotate so that they are pushing material out of the machine, push the left button down. To turn the feedwheels off, push the left button again.

**LOADER SWING (#15):**

The loader swing is located on the cab floor in front of the operators seat. To make the loader swing to the right push down on the right pedal with your right foot. To make the loader swing to the left push down on the left pedal with your left foot.

**CHIPPER HOOD SWITCH - Model 2400 Only (#16):**

The chipper hood open / close switch is located on the side of the chipper base housing, opposite the operator's cab side of the machine. To open the hinged half of the chipper hood, push the switch up. To close the hinged half of the chipper hood, push the switch down.

# Joystick Application For The Loader Function Of Models 1900/2400

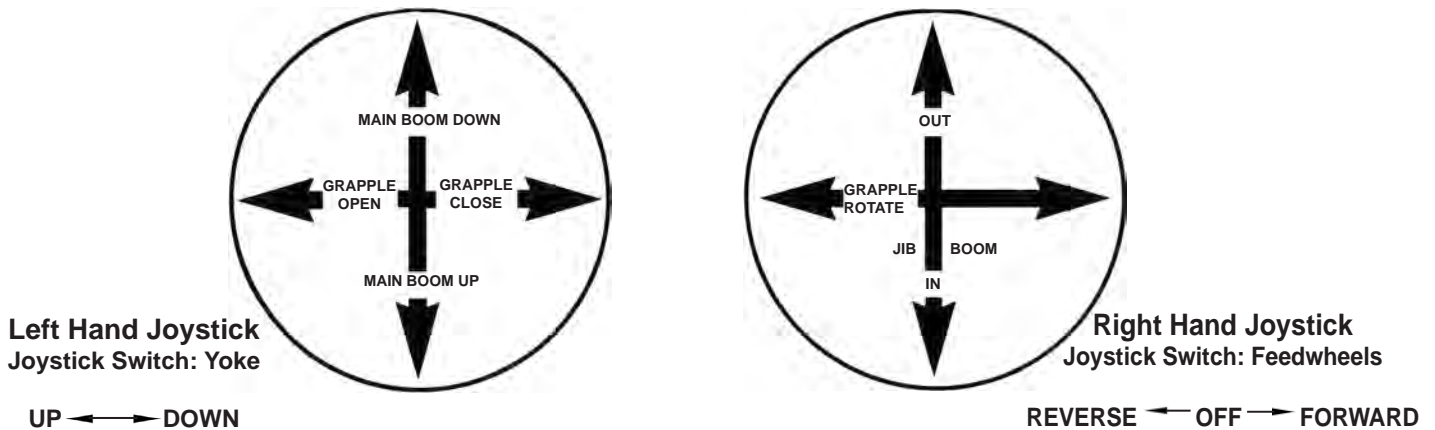

## JOYSTICK OPERATING PROCEDURES LOADER OPERATION

Before beginning to operate the machine make sure you are seated comfortably and are seat belted into the seat.

WHEN OPERATING THE LOADER, THE JOYSTICKS OPERATE IN THE FOLLOWING MANNER:

### LEFT HAND JOYSTICK:

The left hand joystick operates the main boom and the grapple open and close function. To make the main boom move in an upward motion pull the joystick backwards, toward the operator. To make the main boom move in a downward motion push the joystick forward, away from the operator. To make the grapple open push the joystick to the left, toward the outside of the chipper. To make the grapple close push the joystick to the right, toward the loader.

### RIGHT HAND JOYSTICK:

The right hand joystick operates the jib boom and the grapple rotate functions. To make the jib boom move in an outward motion, away from the chipper, push the joystick forward, away from the operator. To make the jib boom move in an inward motion, towards the chipper, pull the joystick backwards, toward the operator. To make the grapple rotate to the left push the joystick to the left, toward the outside of the chipper. To make the grapple rotate to the right push the joystick to the right, toward the loader.

## TRACK OPERATION

Before beginning to operate the machine make sure you are seated comfortably and are seat belted into the seat.

WHEN OPERATING THE LOADER, THE JOYSTICKS OPERATE IN THE FOLLOWING MANNER:

Note: Flip the "function switch" from loader to track.

### LEFT HAND JOYSTICK:

The left hand joystick operates the left side track. To move the left track forward, push the joystick forward, away from the operator. To reverse the left side track, pull the joystick backwards, toward the operator.

### RIGHT HAND JOYSTICK:

The right hand joystick operates the right side track. To move the right track forward, push the joystick forward, away from the operator. To reverse the right side track, pull the joystick backwards, toward the operator.

### HIGH/LOW SPEED SWITCH:

Located on the left joystick console is the High/Low Speed Switch. The switch operates the High and Low speeds for the motors. High speed is for traveling between piles and Low speed is for more torque. When turning, you should be in Low speed.

**CONSULT THE ENGINE MANUFACTURER’S MANUAL FOR  
SPECIFIC CONTROLS FOR TYPICAL DIESEL ENGINES**

**ENGINE OPERATION PRECAUTIONS**

- 1) Engine starting aids, engine block heaters, or extra battery capacity may be required to start your engine during below freezing weather conditions.
- 2) Always check coolant level, and oil level before starting the engine.
- 3) When starting a cold engine, always slowly bring the engine up to operating R.P.M’s. This allows the oil pressure to stabilize as the engine warms up.
- 4) Normal engine coolant operating temperature should remain between 150°F and 200° F.
- 5) If the engine has been operating and the coolant is hot, never remove the radiator cap until the engine has completely cooled off.
- 6) Consult the engine manufacturers manual for specific oil, and oil change recommendations.

**TYPICAL DIESEL ENGINE GAUGES AND CONTROLS**

- A) Oil Pressure Gauge: Indicates the engine oil pressure.
- B) Volts Gauge: Indicates the battery voltage.
- C) Temperature Gauge: Indicates the engine coolant temperature.
- D) Reset Button: This button must be depressed and held while attempting to start the engine. When the engine starts, and the oil pressure is above the low oil pressure shutdown point, release the button. (Not Applicable On Caterpillar Engines.)
- E) Tachometer: Indicates the engine speed.
- F) Ignition Key Switch: Turn and hold the ignition key in the run position while cranking the engine. (Also depress and hold the reset button). Release the key when the engine starts, and release the reset button after the oil pressure stabilizes. (Not Applicable On Caterpillar Engines.)
- G) Before turning off the key, allow the engine to run at idle with no load for 5 minutes to cool down.

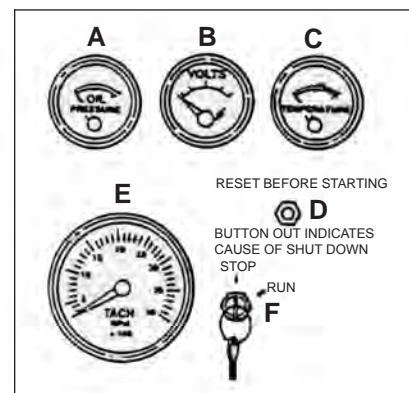

## SPRING LOCK FOR HOOD PIN OPERATION

The spring lock for hood pin, is installed for safety purposes. It is designed to help keep the hood pin from being removed if the chipper disc is turning. NEVER ATTEMPT TO PUSH THE SPRING LOCK FOR HOOD PIN DOWN OR REMOVE THE HOOD PIN, UNTIL AFTER THE ENGINE AND CHIPPER DISC HAVE BOTH COME TO A COMPLETE STOP.

The spring lock is located on the side of the chipper hood. The top of the spring lock should be directly behind the hood pin washer when the hood pin is properly installed in place holding the chipper hood in the closed position (see figure 1).

With the chipper hood shut and hood pin in place the spring lock helps keep the hood pin from sliding out or from being removed if the chipper disc is turning. There is a shaft cam block installed on the chipper shaft which will not allow the spring lock to be pulled down if the chipper disc is turning (see figure 2). When the chipper disc is turning, if the spring lock was to be pulled down or recessed it would simply hit the shaft cam block bouncing the spring lock back into position not allowing for the removal of the hood pin.

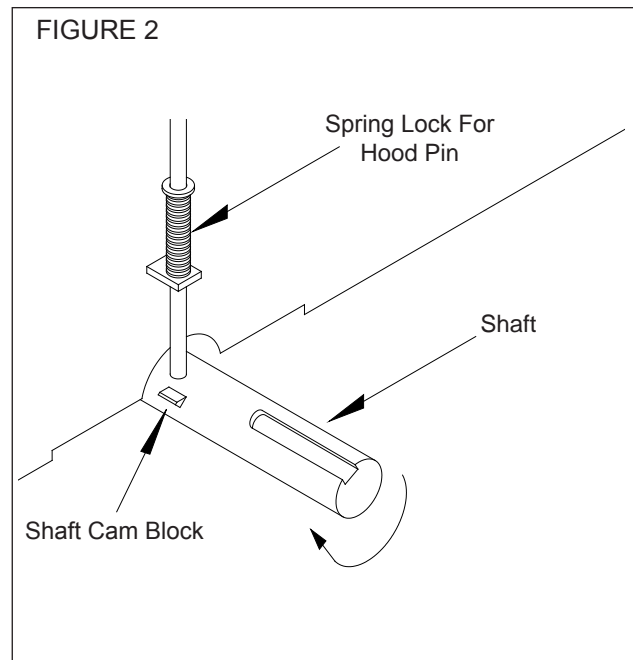
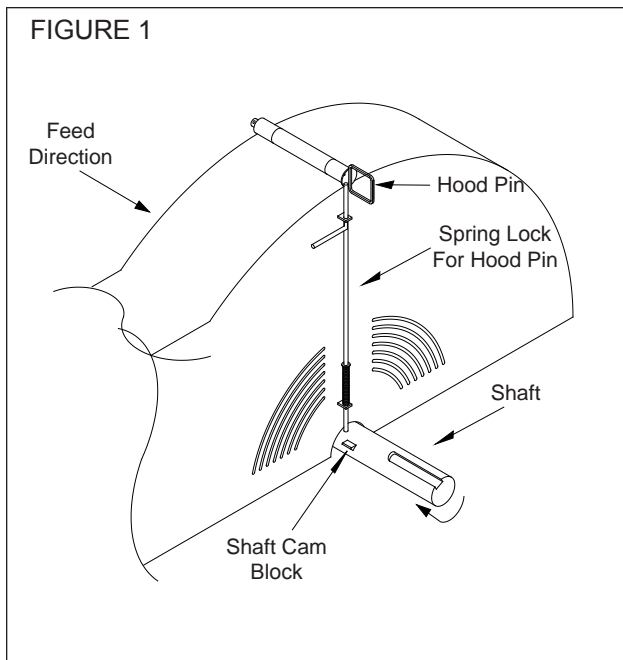

## OPERATION

### **⚠ DANGER**

Avoid moving parts. Keep hands, feet, and clothing away from power driven parts. Keep all guards and shields in place and properly secured. Contact with moving parts will result in serious injury or death.

Never feed any materials that might contain wires, stones, nails, metal objects, or any foreign object which may damage the knives and become dangerous projectiles.

Do not operate this machine without the hood pin in place. Do not operate the machine with any type of makeshift hood pin or an improperly installed hood pin. The hood pin must be padlocked.

Do not attempt to hand feed this machine. This machine is designed to be fed by a mechanical log loader. Feeding material into this machine by hand is not permitted or authorized. Severe injury or death can result!

### **⚠ WARNING**

There must be at least two qualified and trained operators at the work site. They must be positioned in safe working locations, following safety procedures and instructions, and aware of each others' whereabouts.

### **NOTICE**

Do not operate this machine unless all machine controls operate properly. They must function, shift smoothly and accurately at all times.

Make sure machine safety guards are properly installed and safety devices are functioning properly.

Check laws and regulations. Know and obey all laws and regulations that apply to your work situation.

Make sure that all required maintenance has been completed before following the set-up procedures.

## SET-UP

***Before starting the machine, read all safety procedures and watch the start-up and safety videos.***

- Prepare and set up the work site. Make sure there are no loose tools, cans, lines or any other foreign objects in the area. Anything not in use must be stored in a tool box or stowed away.
- Stabilize the infeed hopper and tongue if unhooked from a tow vehicle.
- Do not rely on a tongue jack to keep the machine stable if unhooked from a tow vehicle.
- Make sure to chock the tires.
- Check for and remove any foreign objects in the infeed hopper.
- Make sure the discharge is pointed in a safe direction.
- Adjust the flipper as needed.
- Make sure all personal protective equipment (PPE) is worn. Examples of PPE: hard hat, face shield, gloves (no gauntlet style gloves or secured fit), ear protection, high visibility vest, and steel toe boots.
- Follow all start-up procedures.

## START-UP

1. Follow all engine manufacturer's recommendations for starting the engine.
2. If equipped with a hydraulic clutch, engage the clutch from the control panel. If equipped with a manual clutch, bump the clutch handle until the drum or disc is moving, then fully engage the clutch handle.
3. Throttle the machine up.

## MACHINE OPERATION

1. Once the machine is at full RPM, engage the feedwheels in the forward direction.
2. Feed the machine with a mechanical log loader.
3. Feed large, or butt end, of the branch or log into the infeed hopper first. Never feed this machine by hand.
4. If the limb or log does not feed, it may need repositioned. To reposition, read the following steps:
  - A. Reverse the feedwheels, reposition the limb or log, and feed again.
  - B. The log may need to be removed from the machine to a safe work area and trimmed before attempting to feed again if it still will not feed.

---

# MACHINE OPERATION

## NOTICE

Chippers are not designed to cut chunk wood, dimensional lumber including rail road ties, or end cut logs standing on end. Chipper knives coming in contact with a flat surface puts an extreme shock load on the chipper drum or disc components and bearings. This can cause damage to the machine that will not be covered under warranty.



---

## SHUT DOWN

1. Stop feeding material.
2. Allow the machine to clear out any remaining material.
3. Make sure the top feedwheel is in the lowered position.
4. Throttle the machine down.
5. Disengage the clutch.
6. Wait for the chipper drum or disc to come to a complete stop.
7. Shut the engine off.
8. Remove the key, and make sure it stays in your possession.
9. Allow the machine to cool down
10. Remove all debris, wood chips, sawdust, leaves, etc. from the machine.
11. If transporting the machine, follow the transport procedures.

# Transportation Procedures

## **WARNING**

### **BEFORE TRANSPORTING THE MACHINE THE FOLLOWING MUST BE COMPLETED**

- 1) Idle engine and disengage clutch.
- 2) Make sure the feedwheel is in the lowered position.
- 3) Tuck grapple into infeed hopper, chain down jib boom if equipped.
- 4) Raise the front of machine with the stabilizer legs and remove the stabilization blocks used.
- 5) Couple machine to transport vehicle by lowering the machine onto the hitch. Be sure the stabilizer legs are fully retracted in the upper position. Make sure the hitch matches the coupling size. Then secure hitch and lock it.
- 6) Place all hydraulic controls in the “off” position.
- 7) Turn off engine, wait for the chipper disc/drum to come to a complete stop and you must have the ignition key in your possession.
- 8) Attach the safety chains by crossing them under hitch, make sure to allow the proper amount of slack in chains to avoid binding when making turns.
- 9) Connect the brake lines and make sure the air tank drain valve is closed. Check brakes to make sure they are operating correctly.
- 10) Plug in the electrical connection and check running lights, turn signals, and brake lights. All must be operating properly before transporting the machine.
- 11) Raise the discharge support tube and lower the discharge onto the support tube.
- 12) Do not transport unless discharge is in the transport cradle and the cradle is locked into the transporting position.
- 13) Store all tools in the tool box and make sure all boxes and cabinets are closed and secured.
- 14) Remove all excess debris. Remove any wood or debris which may have collected.
- 15) Check lug nuts and retorque if necessary. Check new units before operation, check again after 20-25 miles and regularly check at least weekly.
- 16) Check tires for correct pressure, cuts or damaged rims.
- 17) Inspect and replace any axle dust caps that are damaged or leaking.
- 18) Check oil level in hubs and grease axles per axle manufacturers manual.
- 19) Walk around the machine to confirm that everything is secure and that there isn't anything loose that could fall off during transport. Look under chipper to ensure nothing is dragging. Look down both sides of the machine for anything sticking out that may become damaged during transport.
- 20) The machine is now ready for transport. Make sure to obey all local regulation and laws regarding the transporting of this type of machine.
- 21) Do not drive too fast for road conditions or exceed speed regulations for equipment towing. Machine must be hauled level and the towing vehicle must be sized to handle hitch weight, towing weight, and braking requirements.

# MAINTENANCE SECTION

The Bandit is a very simple machine to maintain. If you will follow a regular scheduled preventative maintenance program you should have years of trouble free operation.

## **⚠ DANGER**

Before attempting any type of maintenance disengage clutch, install clutch lock, turn off engine, wait for the disc/drum to come to a complete stop, install the disc/drum lock pin, disconnect battery, and make sure the ignition key is in your possession.

## **⚠ DANGER**

Do not let anyone operate or maintain this machine until they have thoroughly read this manual, reviewed the equipment decals, watched the equipment video, and has been properly trained. You can purchase additional Bandit manuals, decals and videos for a nominal fee.

## **NOTICE**

Consult your engine manual for proper break-in procedures. Various engines require somewhat different procedures, but basically the engines need to operate at lower R.P.M.'s and loads for a specific time.

## **NOTICE**

Failure to properly break-in your engine will result in poor bearing and piston ring surfaces.

## **NOTICE**

The Bandit has only been run for a short time to test proper hydraulic pressures, possible leaks, etc. The fuel tank will be empty. Fuel is provided through a small auxiliary tank for testing. This immensely helps maintain safety in our manufacturing facility and while shipping.

## **NOTICE**

Expensive damage to the Bandit will occur if proper preparation is not taken before welding on the machine. Be sure to disconnect both battery cables and the engine ECM (engine control module) before welding. Follow the specific Engine MFG. instructions for proper welding and grounding procedures, before attempting to weld on the machine.

## DAILY START UP & MAINTENANCE

### **1) Check the safety decals and engine gauges:**

Replace any missing or damaged decals and/or engine gauges.

### **2) Check all safety equipment:**

Check for proper operation. Repair or replace as needed.

### **3) Check entire machine for loose bolts, nuts, parts, or components:**

Check entire machine for any loose parts or components. Check for loose nuts or bolts. Torque, tighten, or replace any of the loose components. See page 37 for specific bolt torques. Make sure all guards are tight and securely in place.

### **4) Check chipper hood hinge:**

Make sure the hood hinge operates correctly, and is lubricated. Must replace hinge if damaged. Make sure the hydraulic hood works properly on Model 2400.

### **5) Checking for foreign objects:**

Before opening the hood make sure the clutch is disengaged, the engine off, the disc/drum lock pin is installed, battery is disconnected, and also make sure the ignition key is in your possession. Remove the hood pin padlock, suppress the spring lock for hood pin on disc chippers, and then remove the hood lock pin. Prior steps must be done after opening the hood, on Model 2400, because the engine must be running to open the chipper hood. Look for any foreign objects inside the chipper housing. Remove any foreign objects found.

# Bandit

**DAILY START UP & MAINTENANCE (cont.)****6) Check chipper disc assembly:**

Check for elongated bolt holes, secure welds, torqued bolts, excessive wear and impact cracks. If a problem is found contact the chipper manufacturer or an authorized Bandit dealer. Also check the chipper housing at this time. Check the chipper base, belly band, and hoods for wear or damage. Also inspect the chipper bearings.

**7) Check chipper disc/drum to turn:**

Very carefully, manually with a bar, turn the chipper disc/drum a full revolution. This is to ensure the anvil and knives have proper clearance. If the chipper disc/drum is jammed with debris or frozen in place, DO NOT attempt to start the engine and engage clutch until the chipper disc/drum rotates freely.

**8) Check the condition of your fan blades, knives, anvil, and attaching hardware:**

Grind, file, or replace your knives to keep them sharp. Check the fan blades, anvil, and attaching hardware for the knives and anvil. Replace if necessary.

**9) Properly torque the knife mounting hardware:**

All knife mounting hardware must be factory approved. Knife mounting hardware must be replaced after maximum of 4-5 knife rotations/changes to insure safe clamping ability.

Torque set, AT ALL TIMES to: See Page 37.

**10) Hood lock pin and padlock:**

After closing chipper hood, reinsert the hood pin and padlock, make sure pin is tight and secure. If worn replace immediately. Don't use a worn or makeshift hood pin. Make sure the spring lock for the hood pin is in the correct position on disc chippers.

**11) Grease all feedwheel, and chipper bearings daily:**

Use an EP-2 Lithium type grease only for all bearings. Purge chipper bearings with grease. You can not over grease these bearings. Grease feedwheel bearings with one shot of grease. Both types bearings are designed with a relief system that will not allow over greasing. In other words, you can not hurt the bearing seals by pumping in too much grease. Most of the failures related to bearings are diagnosed as "Contamination". Contamination is caused by improper lubrication. Wipe off excess grease. **Excessive grease will attract dirt.**

**12) Grease knuckle boom loader (if equipped):**

Grease all loader and grapple pins and bushings with 1 to 2 shots of an EP-2 Lithium type grease. Wipe off excess grease. **Excessive grease will attract dirt.** NOTE: May accept grease easier after the loader has been operated.

**13) Check chain drive tension:**

Check tension on all chain drives and tighten as necessary.

**14) Check / adjust the chipper drive belt tension:**

The belts will need to be tightened several times in the first few days of operation. A loose belt will slip and then glaze over. Once they slip you must replace them. Check hydraulic pump drive belts also if equipped. See page 40 for procedures.

**15) Check the hydraulic pump and motor shafts:**

Check the hydraulic pump and hydraulic motor shafts for fit and tightness.

**16) Check hydraulic oil level:**

The hydraulic oil reservoir tank level should always remain at 7/8 full. Remember to check DAILY to avoid excessive heat build up.

**17) Check for any fluid leaks:**

Inspect for any oil, fuel, hydraulic oil, or engine coolant leaks. Check all hoses, fittings, lines, and tanks. DO NOT use fingers or skin to check for hydraulic leaks. Repair or replace any damaged or leaking components.

**18) Check hydraulic control valves:**

Inspect all hydraulic control valves and insure they operate smoothly and shift correctly.

**19) Check the fuel level:**

Check the fuel level, running out and repriming is time consuming.

**20) Check engine oil and coolant level:**

Follow the engine manufacturer manual recommendations for fluid levels. You MUST follow specific ENGINE MFG. manual recommendations for radiator coolant, additives, lubrication, correct engine speed, ETC.

**21) Check radiator, debris screen:**

Thoroughly clean radiator fins at least once a day and twice in excessive conditions. Make sure debris is not packed between fins. Use pressurized water spray to clean. Do not rely on air pressure. The radiator will only appear to be clean. A partially plugged radiator will not allow the engine to cool properly. Clean cooling fan, shroud on air cooled engines, and the debris screen (if so equipped). Improper service, maintenance, or neglect will cause overheating problems and engine failure.

**22) Check air cleaner or precleaner:**

Clean or replace element following engine manual recommendations.

**23) Check clutch:**

Check for proper lubrication, and engagement tension adjustment, frequently adjust and lubricate per PTO clutch manufacturer's manual. Bandit Industries, Inc. does not warranty clutch failures.

## DAILY START UP & MAINTENANCE (cont.)

**24) Check hydraulic clutch fluid level (if applicable):**  
The hydraulic clutch reservoir tank level should always remain at the clutch manufacturer's recommendations. Refer to the clutch manufacturer's manual.

**25) Check tires (if equipped):**  
Check tires for wear, weather checking and damage. Replace if damaged.

**26) Inspect dust caps and adjust brakes (if equipped):**  
Inspect or replace axle dust caps. Inspect and adjust brakes as needed per axle MFG. manual.

**27) Inspect, adjust, and lubricate tracks (if equipped):**  
Inspect, adjust, and lubricate tracks as needed per track MFG. manual.

**28) Block the tires and tongue (if applicable):**  
Before operation block the tires and tongue for stability.

**29) Check the infeed hopper:**  
Check in the infeed hopper for any foreign objects and around the entire machine for tools, cans, saws, etc. All tools not in use should be stored in a tool box.

**30) Check the discharge direction:**  
Make sure the discharge is pointed in a safe direction and locked into place.

**31) Remove transport chain on loader:**  
Remove the transport chain on the loader and store in a tool box.

**32) Review all safety procedures on decals, from manual, and from video.**

**33) Make sure all safety equipment is being worn:**  
Hard hat, gloves, eye protection, ear protection, etc.

**34) Remember to check EVERYTHING on the checklist.**

## WEEKLY MAINTENANCE

**1) Check anvil clearance, tightness, and wear:**  
Measure the anvil clearance. The clearance should be .060 to .080 from highest knife. Check the anvil hardware, make sure the bolts are at the proper tightness. The anvil is a normal wear item, if it is worn you can rotate it to a new working edge. Refer to page 41 for the exact checking of anvil clearance procedure.

**2) Check alternator and fan belts on engine:**  
As applicable adjust and maintain per the engine manufacturer's manual.

**3) Check and retighten tank mount bolts:**  
Check and retighten the fuel tank and hydraulic tank mount bolts.

**4) Check wheel lug nuts (if equipped):**  
Keep lug nuts tight, retorque, replace if needed.

**5) Lubricate all pivoting and hinged areas:**  
Lubricate all pivoting and hinged areas on the machine (i.e. cabinet doors, discharge flipper, etc.)

**6) Lube chain driven components:**  
Use a dry lube on any chain driven components: hydraulic swivel discharge and chain driven feedwheels.

**7) Check and oil feedwheel slide box:**  
Check that feedwheel slide box is working smoothly, oil with 10W/30 type motor oil. Especially new machines need oiling to ensure correct operation during break-in.

**8) Check fluid level in pump bearing block(s):**  
Keep the fluid level in the pump bearing block(s) full, use an 80W/90 type gear lube.

## MONTHLY MAINTENANCE

**1) Check towing hitch:**  
Check for excessive damage or wear. Replace if needed. Keep pintle ring greased to reduce wear.

**2) Check discharge, and infeed hopper wear:**  
Check for wear on discharge, infeed hopper, and discharge direction adjustor, build up, repair or replace as needed.

**3) Inspect feedwheel motor connections, sprockets, and bushings:**  
Check and maintain correct torque, on feedwheel motor connections, sprockets, and bushings. See page 37.

**4) Check feedwheel teeth for sharpness:**  
Replace if needed.

**5) Check chipper bearings and chipper sheave:**  
Check, retighten all bearing bolts, bearing lock collars, and also belt sheave bushings to correct torques.

**6) Check hydraulic pressures on the feedwheel system:**  
Check, reset and maintain all hydraulic feedwheel pressure settings to a maximum of 2100 P.S.I. This will give you the best performance from the hydraulic feed system.

**7) Tire air pressure:**  
Fill each tire to rated capacity on tire.

**8) Check wheel bearings:**  
Check and lubricate wheel bearings per axle manufacturer's instructions.

# Bandit

**3 MONTH MAINTENANCE**

**1) Hydraulic oil filter:**

Must be replaced after FIRST 10 HOURS OF OPERATION, USE A 10 MICRON FILTER, then quarterly or every 400 hours afterwards.

**2) Grease discharge swivel plates:**

Grease swivel plates for discharge as needed.

**6 MONTH MAINTENANCE**

**1) Pump bearing block(s):**

Pack the female splines of the bearing block(s) every 6 months or every 1000 hours with an EP-2 Lithium type grease. See page 43.

**2) Planetary speed reducer:**

Change gear lube after first 50 hours and 100 hours, then every 6 months or every 1000 hours afterwards. Requires 40 oz. of 80W/90 gear lube, keep full.

**YEARLY MAINTENANCE**

**1) Hydraulic oil:**

Change hydraulic oil and flush the hydraulic reservoir tank.

**2) Hydraulic suction screen(s):**

Change hydraulic suction screen(s) yearly or every 2000 hours.

**BOLT TORQUE CHART**

(THESE TORQUES ARE BASED ON DRY, CLEAN THREADS)

DESCRIPTION	BOLT SIZE	TORQUE (FT.-LBS.)
Chipper Bearing Bolts	7/8" - 9 NC	350
Chipper Bearing Bolts	3/4" - 10 NC	250
Chipper Shaft Bearing Retainer	1 1/2" - 6 NC	350
Chipper Shaft Bearing Retainer	1 1/4" - 7 NC	300
Chipper Draw Ring	1" - 14 NF	550
Anvil	5/8" - 11 NC	212
Knife Clamp Nut	7/8" - 14 NF	500
Knife Holder	5/8" - 11 NC	212
Knife Holder	3/4" - 10 NC	250
Knife Holder Height Bar	1/4" - 20 NC	12
Counter Knife Clamp	1/4" - 20 NC	12
Fan Blade	5/8" - 11 NC	212
Wear Plate	1/2" - 13 NC	106
Feedwheel Bearing Bolts	5/8" - 11 NC	212
Feedwheel Bearing Set Screws	3/8" - 24 NF	20
Grip-Tight Feedwheel Bearing Set Screws		2
Engine Hold Downs	3/4" - 10 NC	250
Engine Sheave Bushing "MS"	3/4" - 10 NC	225
Chipper Sheave Bushing "N"	7/8" - 9 NC	300
Autofeed Plus Solenoid Retainer Nut		4 - 6
Hitch Mount Bolts	7/8" - 9 NC	350

Before tightening bolts be sure you have the correct size bolt for the correct amount of torque. Use only factory approved knives and hardware.

**BASIC WHEEL TORQUE REQUIREMENTS (per mfg.)**

**KEEP LUG NUTS PROPERLY TIGHTENED, CHECK NEW UNIT BEFORE OPERATION, CHECK AGAIN AFTER 20-25 MILES AND REGULARLY CHECK AT LEAST WEEKLY.**

5 & 6 Lug Hubs (1/2" - 20 Studs) .....	90 - 120 ft.-lbs. Torque
8 Lug Hubs (1/2" - 20 Studs) .....	90 - 120 ft.-lbs. Torque
8 Lug Hubs (9/16" - 18 Studs) .....	110 - 120 ft.-lbs. Torque
8 Lug Hubs (5/8" - 18 Studs) .....	190 - 210 ft.-lbs. Torque (Cone Nut)
8 Lug Hubs (5/8" - 18 Studs) .....	275 - 325 ft.-lbs. Torque (Flange Nut)
10 Lug Hubs (3/4" - 16 Studs) .....	450 - 500 ft.-lbs. Torque

(Consult axle manufacturers manual shipped with each machine for specific axle-stud-wheel combination lug nut torques.)

**DAILY START UP & MAINTENANCE CHECK LIST**

Each day before starting your machine these checks must be made:

	O.K.	Repaired
1) Check the safety decals and engine gauges, replace if damaged.	<input type="checkbox"/>	<input type="checkbox"/>
2) Check, maintain, and service all safety equipment for proper operation: hood pin, spring lock for hood pin (disc chippers only), etc.	<input type="checkbox"/>	<input type="checkbox"/>
3) Check entire machine for loose nuts, bolts, and components. Make sure all guards are tight and securely in place.	<input type="checkbox"/>	<input type="checkbox"/>
4) Make sure hood hinge operates correctly, is not damaged, and is lubricated.	<input type="checkbox"/>	<input type="checkbox"/>
5) Open chipper hood and check for any foreign objects.	<input type="checkbox"/>	<input type="checkbox"/>
6) Check the condition of chipper disc/drum assembly.	<input type="checkbox"/>	<input type="checkbox"/>
7) Carefully rotate the chipper disc/drum with a bar to insure proper anvil clearance. If chipper disc/drum is jammed with debris or frozen in place, do not attempt to start engine and engage clutch until chipper disc/drum rotates freely.	<input type="checkbox"/>	<input type="checkbox"/>
8) Check the condition of your fan blades, knives, anvil, and attaching hardware.	<input type="checkbox"/>	<input type="checkbox"/>
9) Properly torque knife mounting hardware.	<input type="checkbox"/>	<input type="checkbox"/>
10) After closing chipper hood, reinsert the hood pin and padlock, make sure the hood pin is tight and secure. Make sure the hood lock pin is firmly in place, and the spring lock for hood pin springs back into position on disc chippers.	<input type="checkbox"/>	<input type="checkbox"/>
11) Grease chipper bearings (purge) and feedwheel bearings (1 shot) daily.	<input type="checkbox"/>	<input type="checkbox"/>
12) Grease knuckle boom loader and grapple pins and bushings (1 - 2 shots).	<input type="checkbox"/>	<input type="checkbox"/>
13) Check and/or adjust all chain tensions.	<input type="checkbox"/>	<input type="checkbox"/>
14) Check and/or adjust belt tension on chipper and hydraulic pump belt drives.	<input type="checkbox"/>	<input type="checkbox"/>
15) Check hydraulic pump and motor shafts for fit and tightness.	<input type="checkbox"/>	<input type="checkbox"/>
16) Check and always maintain hydraulic level at 7/8 full.	<input type="checkbox"/>	<input type="checkbox"/>
17) Check all hoses, fittings, lines, and tanks for damage and fluid leaks.	<input type="checkbox"/>	<input type="checkbox"/>
18) Check hydraulic control valves and insure they operate and shift correctly.	<input type="checkbox"/>	<input type="checkbox"/>
19) Check fuel level. (Running out and repriming is time consuming).	<input type="checkbox"/>	<input type="checkbox"/>
20) Check engine oil, coolant levels, and correct engine speed. Follow ENGINE MANUFACTURER'S manual specs.	<input type="checkbox"/>	<input type="checkbox"/>
21) Check radiator and debris screen. Clean as necessary. Clean cooling fan and shroud on air cooled engines.	<input type="checkbox"/>	<input type="checkbox"/>
22) Check air cleaner and precleaner. Clean as necessary.	<input type="checkbox"/>	<input type="checkbox"/>
23) Check clutch for proper engagement tension and lubrication, frequently adjust and grease per PTO manufacturer's manual recommendations.	<input type="checkbox"/>	<input type="checkbox"/>
24) Check hydraulic clutch fluid level per manufacturer's manual recommendations.	<input type="checkbox"/>	<input type="checkbox"/>
25) Check condition of the tires.	<input type="checkbox"/>	<input type="checkbox"/>
26) Check/replace axle dust caps. Adjust brakes, follow axle MFG. instructions.	<input type="checkbox"/>	<input type="checkbox"/>
27) Inspect, adjust, and lubricate tracks per manufacturer's manual recommendations.	<input type="checkbox"/>	<input type="checkbox"/>
28) Block tires and tongue for stability before operation.	<input type="checkbox"/>	<input type="checkbox"/>
29) Check infeed hopper and around the entire machine for any foreign objects, tools, cans, saws, etc.	<input type="checkbox"/>	<input type="checkbox"/>
30) Make sure discharge is pointed in safe direction and locked into place.	<input type="checkbox"/>	<input type="checkbox"/>
31) Remove transport chain on loader and store in tool box.	<input type="checkbox"/>	<input type="checkbox"/>
32) Review all safety procedures on decals, from manual, and from video.	<input type="checkbox"/>	<input type="checkbox"/>
33) Wear all applicable safety equipment: hard hat, gloves, eye protection, ear protection, etc.	<input type="checkbox"/>	<input type="checkbox"/>
34) Remember to check EVERYTHING on the checklist.	<input type="checkbox"/>	<input type="checkbox"/>



### WEEKLY CHECK LIST

	O.K.	Repaired
1) Check anvil clearance, tightness, and wear.	<input type="checkbox"/>	<input type="checkbox"/>
2) Check alternator and fan belts on engine.	<input type="checkbox"/>	<input type="checkbox"/>
3) Check and retighten fuel tank and hydraulic tank mount bolts.	<input type="checkbox"/>	<input type="checkbox"/>
4) Check and retighten wheel lug nuts.	<input type="checkbox"/>	<input type="checkbox"/>
5) Lubricate pivoting and hinged areas (i.e. cabinet doors, discharge flipper, etc.)	<input type="checkbox"/>	<input type="checkbox"/>
6) Use a dry lube on any chain driven component.	<input type="checkbox"/>	<input type="checkbox"/>
7) Check feedwheel slide box is working smoothly and oil.	<input type="checkbox"/>	<input type="checkbox"/>
8) Keep pump bearing block(s) full of gear lube.	<input type="checkbox"/>	<input type="checkbox"/>

### MONTHLY CHECK LIST

	O.K.	Repaired
1) Check towing hitch for wear, keep pintle ring greased.	<input type="checkbox"/>	<input type="checkbox"/>
2) Check discharge, and infeed hopper for wear.	<input type="checkbox"/>	<input type="checkbox"/>
3) Inspect feedwheel motor connections, sprockets, and bushings.	<input type="checkbox"/>	<input type="checkbox"/>
4) Check feedwheel teeth for sharpness.	<input type="checkbox"/>	<input type="checkbox"/>
5) Check, retighten all bearing and chipper sheave bolts.	<input type="checkbox"/>	<input type="checkbox"/>
6) Check hydraulic pressure on the feedwheel system. Set to 2100 PSI.	<input type="checkbox"/>	<input type="checkbox"/>
7) Check and fill tires to rated pressure.	<input type="checkbox"/>	<input type="checkbox"/>
8) Check and lubricate wheel bearings, follow axle MFG. instructions.	<input type="checkbox"/>	<input type="checkbox"/>

### 3 MONTH CHECK LIST

	O.K.	Repaired
1) Replace hydraulic filter after first 10 hours then quarterly or every 400 hours.	<input type="checkbox"/>	<input type="checkbox"/>
2) Grease swivel plates for discharge as needed.	<input type="checkbox"/>	<input type="checkbox"/>

### 6 MONTH CHECK LIST

	O.K.	Repaired
1) Pack the female splines of the bearing block(s) with grease.	<input type="checkbox"/>	<input type="checkbox"/>
2) Change gear lube in planetary speed reducer after first 50 hours and 100 hours, then every 6 months or every 1000 hours afterwards.	<input type="checkbox"/>	<input type="checkbox"/>

### YEARLY CHECK LIST

	O.K.	Repaired
1) Change hydraulic oil and flush the hydraulic tank.	<input type="checkbox"/>	<input type="checkbox"/>
2) Replace hydraulic suction screen(s) annually or every 2000 hours.	<input type="checkbox"/>	<input type="checkbox"/>

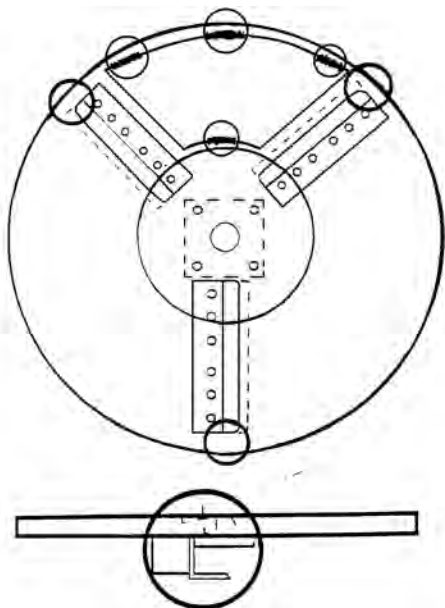

## **⚠ WARNING**

### WHEN YOU CHANGE CHIPPER KNIVES

CHECK CHIPPER DISC ASSEMBLY FOR ELONGATED BOLT HOLES, SECURE WELDS, TORQUED BOLTS, EXCESSIVE WEAR AND IMPACT CRACKS, IF PROBLEM FOUND CONTACT CHIPPER MANUFACTURER, OR AUTHORIZED CHIPPER DEALER. ALSO CHECK WEAR PLATES AND WELDS.

# BELT TENSION

## GENERAL RULES FOR TENSIONING

1. Check tensioning during the first 2 through 48 hours of run-in operation especially.
2. Over tensioning or under tensioning shortens belt and bearing life.
3. Keep belts free from foreign materials that may cause the belt to slip.
4. Make V-drive inspection on a periodic basis. Never use belt dressing as this will damage the belt and cause early failure.
5. Belts should never be forced over the sheave. Allow enough room for belts to slip on.
6. Always make sure sheaves are aligned properly.

## TENSIONING PROCEDURE

### Main Drive Belts

Locate the center of the belt span between the sheaves. Push or pull on the belt until the belt has deflected 1" to 1 1/8". Record the push or pull force. The force should be 140 to 150 lbs./ poly band belt for Model 1900's and 175 to 190 lbs./ poly band belt for Model 2400's. Adjust the belt tension if the force falls outside of this range. If belts are not properly adjusted belts will slip, glaze over, and be ruined. This is NOT covered by warranty.

To adjust the belt tension, loosen the four engine mounting bolts and the jam nuts on the engine adjuster on the radiator end of the engine. Adjust the belt tension with the engine adjuster on the clutch end of the engine. If you have to push the engine with the adjuster, the belts will tighten slightly after engine is realigned. Use the engine adjuster on the radiator end of the engine to realign the engine, so the engine sheave and chipper sheave are aligned. The sheaves can be checked with a string or straight edge or you can measure the distance from the engine frame to the keystick on the engine rail. The keystick is on the engine rail near the engine adjuster. Tighten the two engine mounting bolts (see Torque Chart for correct torque) on the opposite side of the engine from the engine adjusters. Loosen the jam nuts on the engine adjuster on the radiator end of the engine. Tighten the engine mount bolts and then the engine adjuster jam nuts. Hand tighten the remaining engine mount bolt, loosen the engine adjuster jam nut, half a rotation, tighten the engine mounting bolt, loosen the engine adjuster jam nuts all the way and tighten the engine mount bolt again. Tighten the engine adjuster jam nuts. Recheck the belt tension and alignment, readjust if needed.

**NOTE:** It is a good practice to rotate the belts during tensioning. Then recheck deflections. The belts may need to be tightened again.

### Pump Drive Belts (If equipped)

Locate the center of the span between sheaves. Push or pull down on the belt until the belt has deflected 3/8". Record the push or pull down force. The force should be 9 to 11 lbs. Adjust the belt tension if the force falls outside of this range. Do not over tighten the hydraulic pump belt. For best results use a good belt tension tester. Most all pump failures result from too much side load on the pump shaft. Too much belt tension is very easy to detect inside a failed pump. Pumps with this condition will not be covered under warranty.

## DO NOT IGNORE THIS MAINTENANCE RULE!

New belts stretch very soon and must be adjusted several times in the first few hours of operation. Adjust after one hour of operation, then every four hours until the belts quit stretching.

Failure to do this will cause the belts to burn and fly off. **THIS FAILURE IS NOT COVERED BY WARRANTY!**

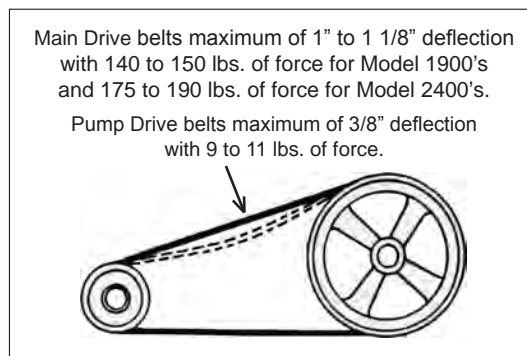
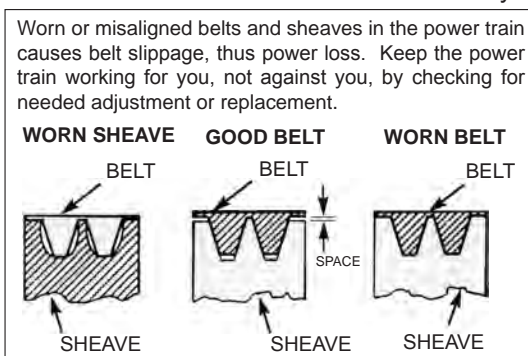

# ANVIL ADJUSTMENT

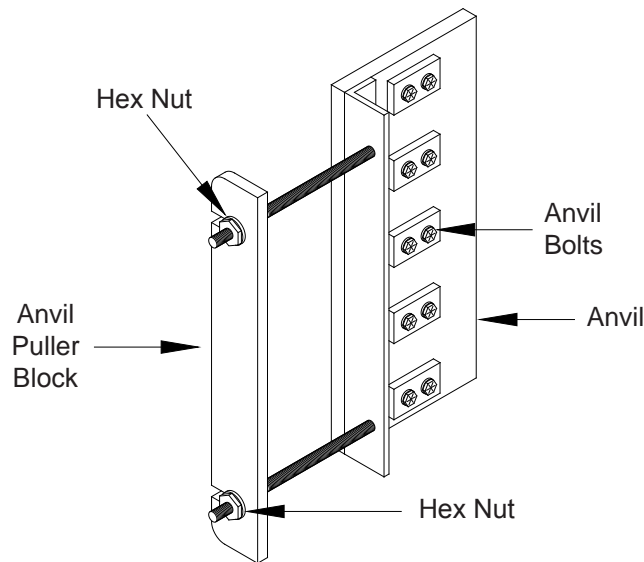

## **⚠ DANGER**

Before attempting any type of maintenance disengage clutch, install clutch lock, turn off engine, wait for the disc to come to a complete stop, install the disc lock pin, disconnect battery, and make sure the ignition key is in your possession.

Before working inside the infeed hopper or under the top feedwheel, raise the yoke, install the yoke lock pin, safety chain the yoke in the raised position, and insert a wooden block to assist in holding the yoke in the raised position.

## **Check the anvil to knife clearance**

This clearance should be checked on a weekly basis. To check the anvil clearance the above safety procedures must be taken. Once all safety procedures are completed the anvil to knife clearance can be checked. In order to check the clearance one person will need to climb into the infeed hopper. Use a feeler gauge or the anvil to knife gauge supplied by Bandit to check the clearance of the first knife to the anvil. Check the clearance at the top and bottom of the anvil. Once that knife has been checked climb back out of the infeed hopper, remove the disc lock pin, and very carefully rotate the chipper disc so the next knife can be checked. Repeat procedure for the third knife.

## **⚠ DANGER**

Do Not under any circumstance attempt to rotate the chipper disc while someone is inside the infeed hopper. They may become seriously injured, Do Not Do This!

Once the disc has been rotated, reinstall the disc lock pin, and then check the clearance between the next knife. Once all knives have been checked adjust the anvil according to the closest knife. The anvil to knife clearance should be .060 to .080 inches. Set the closet knife to this distance.

## **Anvil Adjustment Procedure**

(Refer to above Figure)

To adjust the anvil first loosen all of the anvil bolts. Then loosen two of the hex nuts on either the inside or outside of the anvil puller block. If the anvil needs to be adjusted closer to the disc, loosen the outside hex nuts. If the anvil needs to be adjusted away from the disc, loosen the inside hex nuts. Once the nuts have been loosened, use the anvil adjustment handle to move the anvil. This is a two person job, one to move the anvil and the other to check the clearance. Once the knife is set to the correct clearance, .060 to .080 inches, retighten all components. Make sure bolts are torqued to their specific bolt torques refer to bolt torques on page 37. Carefully rotate the chipper disc to make sure all the knives clear the anvil.

**⚠ DANGER**

Before attempting any type of maintenance disengage clutch, install clutch lock, turn off engine, wait for the disc/drum to come to a complete stop, install the disc/drum lock pin, disconnect battery, and make sure the ignition key is in your possession.

Before working inside the infeed hopper or under the top feedwheel, raise the yoke, install the yoke lock pin, safety chain the yoke in the raised position, and insert a wooden block to assist in holding the yoke in the raised position.

**NOTICE**

Expensive damage to the Bandit will occur if proper preparation is not taken before welding on the machine. Be sure to disconnect both battery cables and the engine ECM (engine control module) before welding. Follow the specific Engine MFG. instructions for proper welding and grounding procedures, before attempting to weld on the machine.

**REPLACING FAN BADES**

If you notice that your fan blades inserts are getting thin, you should replace them. Always remember to check the chipper disc for balance after you are through replacing the fan blades.

NOTE: Make sure to ground welder directly to disc/drum when welding on any parts that rotate with the disc/drum. Failure to do so, will cause bearing failure.

**REPLACING WEAR PLATES**

The wear plate's primary function is to save wear and tear on the chipper disc. After extended use, the wear plates will have to be replaced. To replace the plates, first remove the bolts, then torch or grind out the stitch welds. Before you install the new wear plates, grind the face of the chipper disc smooth where ever there was a stitch weld, to make sure the new wear plate is tight against the chipper disc. Once the new plates are in place, stitch weld the wear plates to the chipper disc where the previous welds were located.

**REPLACING BELLY BAND**

Remove both halves of chipper hood. The belly band is welded on each end. Remove weld with grinder and slide out old belly band around the chipper disc. Install new belly band and weld one end flush with top of chipper housing. Push down on free end making sure bottom of belly band is down against bottom of chipper housing. Now weld free end to top of chipper housing. Trim off any excess belly band extending above weld at chipper housing.

**REBUILDING CHIPPER HOUSING**

After extended use (check this every month or if quality of chips drop) you will see wear on the bottom plate of the throat where it attaches to the chipper housing. This should be built up to form a square corner as shown with hard surface welding rod. Clamp a brass bar on the inside edge so that it forms a square corner when you fill it in with weld. Grind smooth after you are done welding.

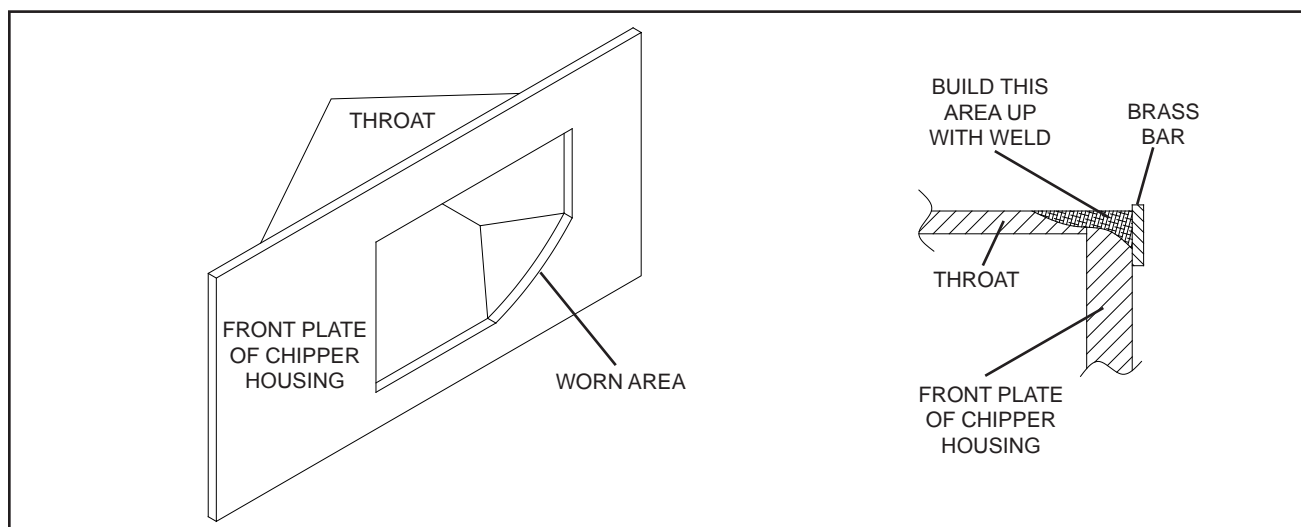

**SERVICING BEARING BLOCK**

Your machine maybe equipped with bearing block(s) and hydraulic pump(s) that are belt driven. The female splines in the bearing block need to be packed with an EP-2 Lithium type grease every six months. To do this, unbolt the hydraulic pump from the bearing block and slide the hydraulic pump out of the bearing block. There is no need to loosen or remove the drive belts or hydraulic lines. Once the hydraulic pump is removed from the bearing block, inspect the internal splines of the bearing block and the external splines of the hydraulic pump. The tops of the splines should be flat. If the splines are pointed, they are wore and need to be replaced. If the splines are good, pack the internal splines of the bearing block with an EP-2 Lithium type grease, reinstall the hydraulic pump, and bolt the hydraulic pump to the bearing block.

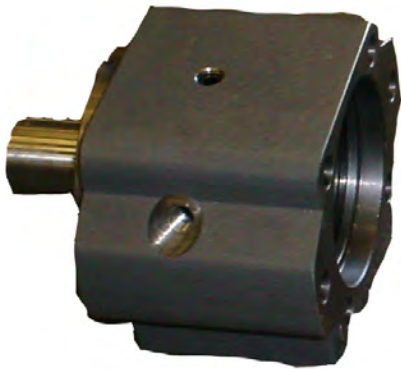

**BEARING BLOCK**

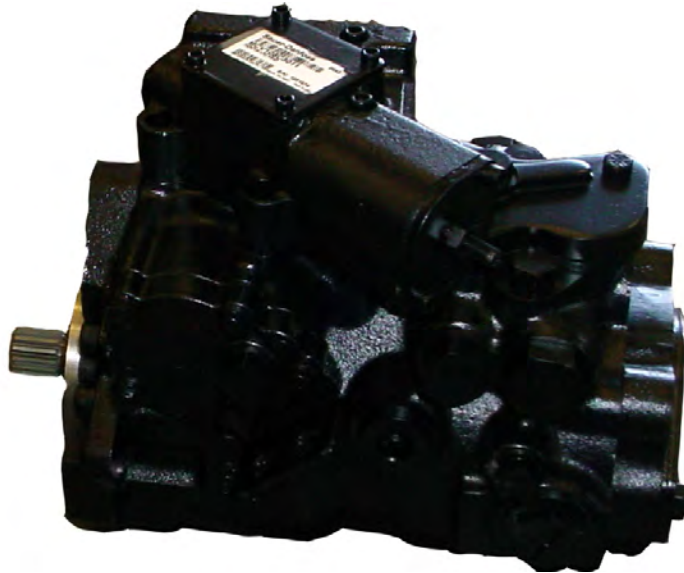

**HYDRAULIC PUMP**

**INTERNAL SPLINES OF THE BEARING BLOCK**

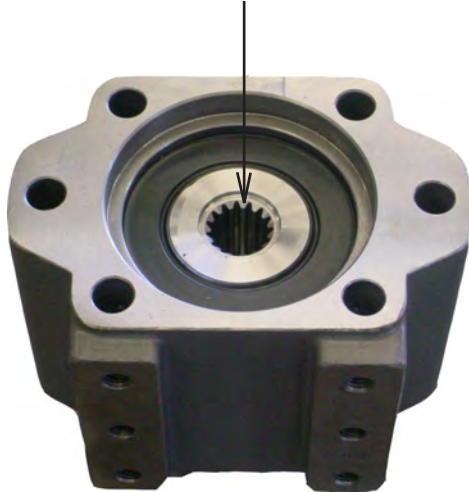

**EXTERNAL SPLINES OF THE HYDRAULIC PUMP**

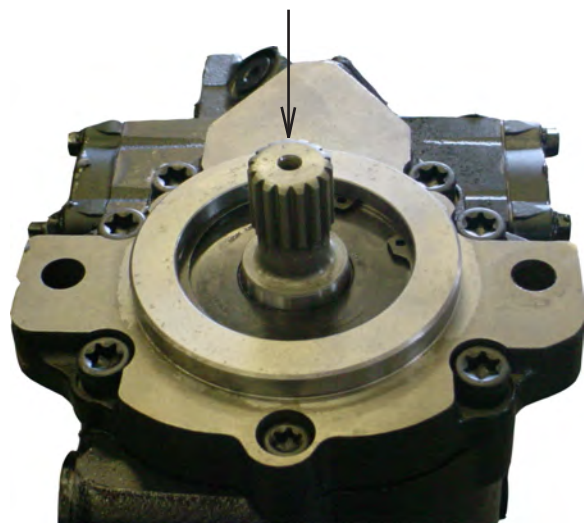

## SERVICING / CHANGING FEEDWHEEL BEARING (WITH THE GRIP TIGHT BEARING BEHIND FEEDWHEEL SPROCKET)

Your Bandit Chipper maybe equipped with a tapered lock style (Grip Tight) feedwheel bearing on one side of the feedwheel and a conventional (set screw) style on the opposite side. With the Grip Tight bearing this gives a very positive locking system to the feedwheel shaft. The set screws on both bearings should still be checked as part of normal maintenance.

A few simple rules and installation instructions must be followed if the bearings ever need to be replaced or removed during service.

The machine is set up with one set screw bearing and one Grip Tight bearing because the one Grip Tight bearing is all that is needed to securely hold the feedwheel shaft (along with the set screws on the opposite bearing). This also makes for very easy assembly. **When installing the bearing it is very important to install and lock the Grip Tight bearing first with the set screw bearing done after.** This is to keep the bearings from being put into a side load which will lead to premature failure.

### Installation procedure:

- 1) Clean the feedwheel shaft of all debris, use a degreaser.
- 2) Install both feedwheel bearings on the feedwheel shaft with the Grip Tight bearing on the hydraulic motor side and the set screw bearing on the opposite side. **Do not lock the bearings on the shaft at this time, allow the feedwheel to shift freely for installation.**
- 3) Position the feedwheel in the yoke mount and install all (8) feedwheel bearing bolts using Loc-Tite 271. These are completely tightened and torqued at this time (refer to bolt torque chart).
- 4) The feedwheel then needs to be centered in the yoke and then it must be off set 3/16" towards the set screw bearing side (away from the hydraulic motor). The weight of the feedwheel motor needs to be taken off the bearings also.
- 5) First the Grip Tight bearing lock nut must be tightened by hand as tight as possible (in a clock wise direction). This is the zero reference point. Scribe a line on the lock nut above the adapter slot.
- 6) Using a spanner wrench or drift pin and hammer, lock the bearing to the shaft by tightening the lock nut in a clock wise direction. Tighten 3/4 to 1 full turn (you may need to block the feedwheel from turning at this time). Now you can tighten the set screws on the Grip Tight bearing. Note: the set screw is only to be tightened to 25 in.-lbs. (2 ft.-lbs.).
- 7) Now tighten the set screws on the set screw bearing at 20 ft.-lbs.

**Grip Tight Bearing**



**Set Screw Bearing**



# MAINTENANCE

## PROCEDURE FOR UNPLUGGING YOUR CHIPPER

If your chipper is plugging, it is usually caused by allowing the engine to drop below required R.P.M.'s. This can be resolved by simply shutting the feedwheel(s) off when the engine begins to lug down. Operating the engine at speeds lower than full R.P.M.'s causes your chipper to plug. **Always run the chipper at full engine speed.** Your chipper is equipped with the autofeed feature, make sure it is set correctly. The setting for the low R.P.M. stop must be high enough not to allow the chipper discharge to plug. Dull chipper knives also contribute to chipper plugging. Dull knives can create slivers and chunks, causing the engine to lug excessively. Both of the aforementioned conditions cause a plugging situation.

### STEPS TO FOLLOW WHEN UNPLUGGING YOUR CHIPPER

1. Before attempting any type of maintenance disengage clutch, install clutch lock, turn off engine, wait for the disc/drum to come to a complete stop, install the disc/drum lock pin, disconnect battery, and make sure the ignition key is in your possession.
2. Make sure the chipper disc/drum is **NOT** turning and then open the hinged portion of the chipper hood.
3. Using gloved hands and some type of raking tool, dig the chips out of the chipper housing.
4. If the discharge chute is plugged, use a raking tool to pull the majority of chips out of the open outlet end of the chute. A clean out door and a hinged straight section is provided to aid in the clean out procedure.
5. Never allow one person to turn the chipper disc/drum when someone else is working inside the chipper housing. More than likely, the chipper disc/drum will turn hard then loosen causing it to turn faster. If another person is anywhere near the chipper disc/drum, they may be injured.
6. Never turn the chipper disc/drum by hand. Always use a pry bar. This will prevent the person turning the disc/drum from being injured should the disc break loose.
7. Never leave the chipper hood open and try to start the engine in order to engage the chipper disc/drum to blow chips out of the housing, this is very hard on the P.T.O. of the chipper and may burn clutch plates. Also, the flying debris is very dangerous. An exposed chipper disc/drum turning very fast creates an unsafe condition. In other words, **DO NOT** start the chipper with the hood open because it is just too dangerous.
9. Once the disc/drum turns freely, close the chipper hood, insert the hood pin, install the padlock in the hood pin, make sure the spring lock for hood pin springs back to the correct operating position on disc chippers, start engine, properly engage clutch and throttle to full speed. Insert a small branch into the feedwheel(s). If the chips discharge properly, the chipper is clear and normal operation may resume.

## PAINT CARE

To help keep up the appearance of your Bandit Equipment and reduce the possibility of surface rust follow these steps:

- 1) The machine should be washed on a regular basis with a non-abrasive mild detergent and then rinsed thoroughly. Do not pressure wash sensitive areas like: decals, gauges, electronic devices, autofeed control, etc.
- 2) If a stone chip, paint scratch, or paint crack occurs - it should be repaired immediately. Simply sand the edges of the damaged paint area, mask off the surrounding area and apply primer and paint to the dry, clean, and warm surface.  
This will help keep the damaged area from spreading or getting worse.
- 3) If you are unable to sand and mask the area, there are containers of primer and paint available. A small brush can be used to touch up the area.
- 4) Also, primer and most colors of paint are available in aerosol spray cans to simply spray over the effected area after it is cleaned, dry, and warmed. This method is not as reliable as the process in step #2.

It is also reported that some equipment owners polish their machine at least yearly, and keep good mud flaps on their towing trucks.



## DANGER

### LOCK OUT ALL ENERGY SOURCES BEFORE SERVICING OR REMOVING GUARDS OR HOODS!







1. Shut off engine/motor. Key in pocket.
2. Disengage pto/clutch.
3. Wait for cutter disc/drum to come to a **COMPLETE STOP** (takes at least several minutes).
4. Install disc/drum lock pin.
5. Loader arm (if equipped) securely on ground and hydraulic pressure released.
6. Unplug engine disable plug.
7. Remove padlock from hood pin.
8. Retract hood pin.



**DO NOT RESTART UNTIL ALL GUARDS  
AND HOODS ARE SECURELY AND  
PROPERLY REINSTALLED**

# TIRE WEAR DIAGNOSTIC CHART

Wear Pattern		Cause	Action
	Center Wear	Over Inflation	Adjust pressure to particular load per tire catalog
	Edge Wear	Under Inflation	Adjust pressure to particular load per tire catalog
	Side Wear	Not Hauling Trailer Level Bent Axles Wide Tires Wheel Bearings	Must be hauled parallel to ground Replace as needed Characteristic of wide flotation tires Adjust or replace
	Cupping	Out-Of-Balance Wheel Bearings	Check bearing adjustment and balance tires Adjust or replace
	Flat Spots	Wheel Lock Up & Tire Skidding	Avoid sudden stops when possible and adjust brakes.

The wear pattern and tread life of tires involves many variables that the user has control of, but **DOES NOT** fall under faulty manufacture or design.

The following is a list of some causes supplied by tire suppliers and axle manufacturers:

- Misalignment - from rough roads, pot holes, excessive speeds and hitting curbs.
- Tire Width - the wider the tire for flotation, the more uneven the tire wear.
- Tire Air Pressure - too much or too little, for the load.
- Vehicle Hitch Height - if trailer is not level with ground, axle camber is misaligned.
- Maintenance - wheel bearing lubrication and adjustment. Follow axle MFG. instructions.
- Brakes - uneven or misadjusted brakes cause irregular brake activation.

### RECOMMENDED BRAKE ADJUSTMENT PROCEDURE PER AXLE MANUFACTURER.

The proper clearance between the shoe and drum surfaces will be set up initially from our factory to assure proper operation during the normal break in period. No further adjustment will be necessary until the vehicle completes the recommended break in period of 200 miles.

Since all brakes of this type must be burnished or “run in” before their full effectiveness can be achieved, the MFG. maintenance manuals call for readjustment after the first 200 miles of operation. This usually allows ample time for the burnishing to take place. Readjustments is not necessary for brakes fitted with self-adjustment features although periodic inspection is suggested.

The following shows the correct adjustment for the MFG. brakes of 12 1/4” diameter and 16 1/2” diameter.

**NOTICE: Clearances that are too small will result in excessive drag and overheating while too much clearance can render the brake nonfunctional.**

AXLE SIZE	SIZE	TYPE	DIAMETRICAL CLEARANCE	CLICKS TO BACK OFF
15,000 LBS.	12 1/4” X 5”	Air	.040”	AUTOMATIC ADJUSTING
25,000 LBS.	16 1/2” X 7”	Air	.030”	AUTOMATIC ADJUSTING

For additional brake adjustment procedures consult the axle manufacturer manual.

# HYDRAULIC SECTION

**⚠ WARNING**

**DO NOT GO NEAR HYDRAULIC LEAKS!**

High pressure oil easily punctures skin causing serious injury, gangrene, or death. If injured, seek emergency medical help. Immediate surgery is required to remove oil. DO NOT use fingers or skin to check for leaks. Lower load or relieve hydraulic pressure before loosening fittings.

DO NOT operate this machine unless all hydraulic control devices operate properly. They must function, shift and position smoothly and accurately at all times. Faulty controls can cause personal injury!

## Hydraulic Fluid Requirements

This machine is equipped with “Petro-Canada Hydrex XV” hydraulic fluid. It is recommended to replace with the same. “Petro-Canada Hydrex XV” is an all season hydraulic fluid. This is a premium performance, long life anti-wear, hydraulic fluid, designed for all season use in heavy duty hydraulic systems. “Petro-Canada Hydrex XV” allows year round use under wide extremes of temperature. It allows the hydraulic system to start at temperatures as low as -40°C/-40°F, under no load conditions and it improves lubrication of hydraulic components at high operating temperatures. It will also help protect against hydraulic failures during the wide temperature swings of spring and fall. To find the closest “Petro-Canada Hydrex XV” dealer call 1-888-284-4572.

Multi Viscosity motor oils not recommended to mix with “Petro-Canada Hydrex XV” hydraulic oil. AW oils may mix with “Petro-Canada Hydrex XV” hydraulic oil. The following are specifications and authorizations of compatible oils. Only a high quality anti-wear (AW) hydraulic oil containing foam, corrosion, rust and oxidations inhibitors should be used. This viscosity grade depends on the oil temperature in service, based on the climate and operating conditions.

	Hydrex XV	ISO 22, AW	ISO 32, AW	ISO 46, AW	ISO 68, AW	ISO 100, AW
Viscosity Index	>235	>95	>95	>95	>95	>95
Flash Point	>240°C /464°F	>200°C /395°F	>210°C /410°F	>220°C /430°F	>220°C /430°F	>240°C /464°F
Oxidations Stability (ASTM D0943)	>9,000 Hours	>3,000 Hours	>3,000 Hours	>3,000 Hours	>3,000 Hours	>3,000 Hours
Cold Start-up, No Load, Max	-40°C/-40°F	-34°C/-29°F	-26°C/-14°F	-19°C/-3°F	-9°C/16°F	-4°C/24°F

## Hydraulic Fluid For “PT Tech” Clutch

If machine is equipped with a “PT Tech” hydraulic clutch, the clutch must use “Mobil” Fluid #424, per clutch manufacturer’s recommendations. Refer to clutch manufacturer’s manual for more information, fluid level, inspection, and service.

## Hydraulic Fluid For “Twin Disc” Clutch

If machine is equipped with a “Twin Disc” hydraulic clutch, the clutch is equipped with “Petro-Canada Duron” SAE 30W oil. If changing oil, could use SAE -API Class CD or CC: meet Caterpillar TO-2 transmission oil specifications or meet Allison Type C-4 transmission fluid specifications, per clutch manufacturer’s recommendations. Refer to clutch manufacturer’s manual for more information, fluid level, inspection, and service.

**Bandit**

# HYDRAULIC SECTION

Alternate hydraulic oils are available, but they do not equal the performance or longevity of the “Hydrex XV” oil. Consult the following information supplied by the oil distributor.

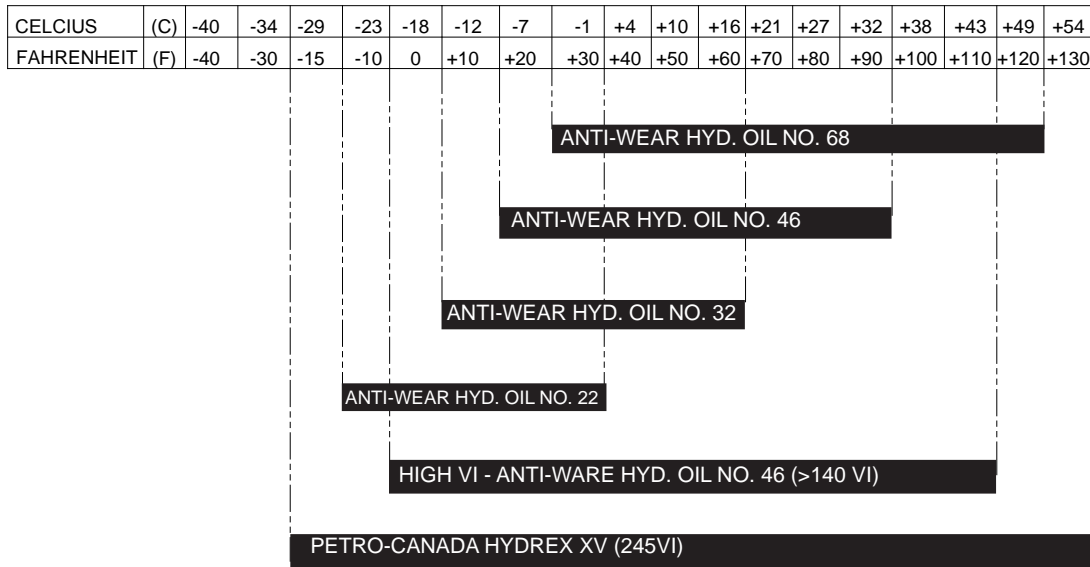

**Note:** The above chart is a suggested guide for viscosity of hydraulic fluids at start up ambient temperature. The load, demand, and cleanliness of the equipment will affect actual oil temperatures which can increase dramatically above ambient air temperatures during operation. The actual viscosity needed is based on oil temperature during operation and not air temperature. Compare your fluid specifications with the specifications below to verify compliance.

When choosing a hydraulic fluid - these maximum and minimum specifications must be met:

- Minimum Viscosity during operation = 12 cSt
- Maximum No-Load Viscosity at start-up = 2000 cSt

Hydraulic fluids vary in their resistance to oxidation at elevated temperatures, their ability to protect against metal-to-metal contact under increasing temperature, and their ability to separate water from the fluid. Viscosity is temperature dependant. Fluids with high viscosity-index (VI) will thin out slower at higher temperature and thicken slower at colder temperatures allowing a wider operating range. Choose a fluid that has test results in these areas for best results.

Based on the varying temperatures of the area where Bandit equipment is used, and the high demand and loads placed on this equipment, Bandit has filled each hydraulic system with Petro-Canada’s Hydrex XV All Season Hydraulic Fluid for maximum protection and performance.

Contact Petro Canada at (888) 284-4572 to find a dealer near you.

**Note:** Some equipment and components such as fluid engagement clutch’s (PTO’s) have their own lubrication requirements. Consult their manufactures manual for that information.

# MODELS 1900/2400

## TYPICAL HYDRAULIC RELIEF PRESSURE SETTINGS AND FLOWS (Approximate, For Reference Only, Engine At Full RPM)

Track (each) - GPM	43
Top Feedwheel - GPM	40.5
Bottom Feedwheel - GPM	40.5
Side Feedwheel and Stabilizers - GPM	14.3
Loader Swing and Grapple Rotate - GPM	11.5
Jib Boom - GPM	24
Main Boom and Grapple Open & Close - GPM	24
Joystick - GPM	2.6
Track Relief - PSI	5000
Top Feedwheel Relief - PSI	2100
Bottom Feedwheel Relief - PSI	2100
Side Feedwheel Relief - PSI	2100
Loader Swing Relief - PSI	2000
Main Boom Up Relief - PSI	2000
Main Boom Down Relief - PSI	800
Jib Boom Up Relief - PSI	2300
Jib Boom Down Relief - PSI	2200
Rotobec Grapple Rotate Relief - PSI	1200 - 1500
Rotobec Grapple Open & Close Relief - PSI	2000
Yoke Lift Up Relief - PSI	1800
Yoke Lift Down Relief - PSI	1500
Swivel Discharge Relief - PSI	1000
Stabilizers Relief - PSI	2000
Joystick Relief - PSI	350 - 400

**NOTICE**

DO NOT UNDER ANY CIRCUMSTANCES OVER-SET THESE RELIEF PRESSURES, BECAUSE IT WILL CAUSE DAMAGE TO COMPONENT PARTS AS WELL AS HYDRAULIC PARTS.

**NOTE:** These Typical Hydraulic Flows And Relief Pressure Settings Are With The Engine At Full RPM. All Settings Are Subject To Change!

**NOTE:** For Machines With An Optional Chip Size, Hydraulic Charts Are Available Upon Request.

# HYDRAULIC SECTION

## THE BANDIT HYDRAULIC SYSTEM

The Bandit is equipped with a very efficient, simple hydraulic system. Each component is capable of withstanding a specified PSI and still operate for a very long time.

If the simple rules mentioned below are followed, the hydraulic components will last for years:

- Avoid hydraulic pump cavitation. Low oil levels or cold start-ups will cause the hydraulic pump to cavitate. Cavitation will ruin the pump and possibly the entire hydraulic system. Cavitation only has to happen once. This will start the pump on its way to ruin. Allow hydraulic system to turn slowly for several minutes in cold weather in order for hydraulic system to warm up. Cavitation is not covered under warranty.
- Do not increase the feedwheel relief valve setting beyond 2100 PSI. This will cause damage to hydraulic components. Do not set any other hydraulic component past it's specified pressure or this will cause damage to the hydraulic components.
- Keep hydraulic oil clean. Dirty oil will cause excessive wear and loss of feedwheel power. Replace filter(s) per maintenance chart.

- Replace the hydraulic oil filter(s) with each 400 hours of operation or 3 months. See pages 48 - 49 for hydraulic oil requirements.

- Replace hydraulic oil & suction screen(s) once yearly. This is also a very good time to flush and clean the tank. Replace hydraulic oil immediately if it is contaminated or looks "milky".

- If the Bandit's hydraulic system is kept clean and the feedwheel hydraulic pressure is not increased beyond 2100 PSI, the maximum use and life should be received from the Bandit chipper hydraulic system.

- If a problem is encountered, it will more than likely be located in a relief valve or something as simple as belts slipping, check these first.

- Do not close the optional hydraulic shut-off valve for more than 3 to 4 seconds. Hydraulic shut-off valve handle must be completely turned on (in line with hose) at all times unless working on or testing hydraulic system. Pressure gauge should be safely stored and installed only when checking pressure. Follow above instructions or this will cause unwarranted damage to the hydraulic components.

## HYDRAULIC MAIN RELIEF ADJUSTMENTS

### CHECKING AND ADJUSTING RELIEF VALVE PRESSURE

#### **WARNING**

Before attempting any hydraulic pressure settings, disengage clutch, install clutch lock, turn off engine, wait for the disc to come to a complete stop, install the disc lock pin, disconnect battery, and make sure the ignition key is in your possession.

1. First locate the relief valve to be checked.
2. Remove cap from diagnostic port and plug pressure gauge into the diagnostic port.
3. Start the engine and open throttle to full RPM. NOTE: Oil must be at operating temperature.
4. To check the cylinder pressures, hold cylinder in the fully extended and fully retracted positions for 4-5 seconds to receive pressure reading. Feedwheel valves are provided with shut-off valves for checking pressure. To check feedwheel pressure, turn shut-off valve to off position for 4-5 seconds to receive pressure reading.
5. Pressure gauge should read the maximum specified pressure. See page 50 for the correct pressure settings. **ONLY HAVE "TESTING" SHUT-OFF VALVE CLOSED FOR 4-5 SECONDS OR YOU MAY DAMAGE HYDRAULICS.**
6. To readjust pressure, if needed, first remove hex head cap and then loosen jam nut. There will be either a set screw or an allen head screw for adjustment. To increase the pressure turn the screw in and to lower the pressure turn the screw out. When pressure is set, reassemble the main relief.
7. Remove pressure gauge from the diagnostic port and put cap back on.
8. Check for hydraulic leaks.
9. Relief valve pressure should be checked and/or readjusted every month for best performance.

# Bandit

# HYDRAULIC SECTION

## MAINTENANCE PROCEDURE FOR HUSCO

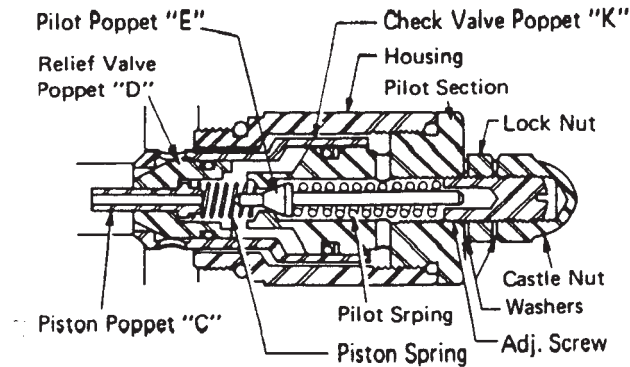

There are several variations to the Service Port Reliefs. However, all are similar in nature regarding service and repair.

### How to Set Pressure on Service Port Relief

A good pressure gauge must be installed in the line which is in communication with the service port relief. A load must be applied in a manner to reach the set pressure of the port relief unit. Then, follow these steps:

- Remove castle nut and loosen lock nut.
- Use a screwdriver and set adjusting screw to desired pressure setting.
- Tighten lock nut and reassemble castle nut.
- Retest in similar manner as above.

The relief does not have a stop to keep from coming all the way out. When backing off the relief, make sure there are no loads on the hydraulic functions. If there was a load on the valve and the relief was backed out all the way, it would blow out of the valve.

## TROUBLESHOOTING - RELIEF VALVE

PROBLEM	POSSIBLE CAUSE	SOLUTION
Can't get pressure.	1. Poppet D, E, or K stuck open or dirt under seat of frame.	1. Check for foreign matter between poppets D, E, or K and their mating members. Members must slide freely.
Erratic pressure.	1. Pilot poppet seat damaged. 2. Poppet C sticking in D.	1. Replace damaged parts. 2. Clean contamination and remove surface marks for free movement.
Pressure setting not correct.	1. Wear due to contamination. 2. Lock nut and adj. screw loose.	1. Replace worn parts. 2. See "How To Set Pressure On Service Port Relief".
Leaks.	1. Damaged seats. 2. Worn o-rings. 3. Parts sticking due to contamination.	1. Check seats for scratches, nicks, or other marks. Replace damaged parts. 2. Replace worn parts. 3. Inspect for free movement of components.

## SERVICE AND REPAIR INFORMATION

The cartridge type service port reliefs used in the Husco valves are of the pilot poppet type with external adjustment. Any malfunctioning is usually the result of foreign matter lodging between the piston, relief valve poppet, and check valve.

To perform service, clean the surrounding area and remove the complete relief valve cartridge. Examine the seat in the main valve housing and if grooves or ridges are present, the cartridge must be replaced.

The design of the pilot poppet and its seat provides positive seating and very seldom requires any maintenance. Therefore, the pilot section can be removed from the cartridge housing without disturbing the setting. It will come with the check valve poppet and other internal parts. These are

easily disassembled and should be examined for foreign matter. All seats and seating surfaces should be smooth and free of nicks, scratches, or grooves. Examine o-rings and back-up washers for any damage. Any parts found to be faulty must be replaced. All moving parts should slide freely, with only seal friction being present.

After inspecting and cleaning, immerse all parts in hydraulic oil and reassemble. Since pressure setting was not disturbed, unit can be tested for proper functioning under actual working conditions.

If operating difficulties indicate that the pilot poppet is leaking or sticking, remove internal parts of the pilot section, and follow same procedure as shown.

**Bandit**

## HYDRAULIC SYSTEM TROUBLE SHOOTING

**Before attempting any type of maintenance disengage clutch, install clutch lock, turn off engine, wait for the disc/drum to come to a complete stop, install the disc/drum lock pin, disconnect battery, and make sure the ignition key is in your possession!**

PROBLEM	POSSIBLE CAUSE	SOLUTION
<b>Feedwheel(s) turn at normal speed but does not chip wood properly</b>	<ol style="list-style-type: none"> <li>1. Dull Knives</li> <li>2. Worn feed teeth</li> <li>3. Low feedwheel relief valve setting</li> <li>4. Worn pump</li> </ol>	<ol style="list-style-type: none"> <li>1. Replace knives</li> <li>2. Replace</li> <li>3. Readjust to 2100 PSI</li> <li>4. Replace</li> </ol>
<b>Feedwheel(s) slow or stop when feeding</b>	<ol style="list-style-type: none"> <li>1. Dull knives</li> <li>2. Relief valve is worn or dirty</li> <li>3. Pump is worn</li> <li>4. Motor is worn</li> </ol>	<ol style="list-style-type: none"> <li>1. Replace knives</li> <li>2. Clean, reset or replace</li> <li>3. Replace</li> <li>4. Replace</li> </ol>
<b>Feedwheel(s) turn slowly or not at all</b>	<ol style="list-style-type: none"> <li>1. Relief valve stuck open</li> <li>2. Worn hydraulic motor</li> <li>3. Pump worn</li> <li>4. Feedwheel Relief pressure off</li> <li>5. Pinched or damaged hydraulic hose</li> <li>6. Feedwheel valve (control valve) worn &amp; leaking internally</li> <li>7. Low hydraulic oil level</li> <li>8. Plugged oil screen</li> <li>9. Binding such as worn bearings, etc.</li> <li>10. Controller improperly shifting valve</li> </ol>	<ol style="list-style-type: none"> <li>1. Clean or replace</li> <li>2. Replace</li> <li>3. Replace</li> <li>4. Reset to 2100 PSI</li> <li>5. Replace</li> <li>6. Replace</li> <li>7. Fill 7/8 full minimum</li> <li>8. Replace</li> <li>9. Repair</li> <li>10. Readjust, valve must open completely</li> </ol>
<b>Hydraulic oil very hot, causing system to operate slowly</b>	<ol style="list-style-type: none"> <li>1. Dull knives</li> <li>2. Low oil level</li> <li>3. Worn pump</li> <li>4. Relief valve stuck open or opens easily</li> <li>5. Damaged hose</li> <li>6. Oil suction screen or filter plugged</li> <li>7. Worn motor</li> <li>8. Binding</li> <li>9. Operator running oil over relief too much</li> </ol>	<ol style="list-style-type: none"> <li>1. Replace knives</li> <li>2. Fill 7/8 full minimum</li> <li>3. Replace</li> <li>4. Clean, reset or replace</li> <li>5. Replace</li> <li>6. Clean or replace</li> <li>7. Replace</li> <li>8. Repair</li> <li>9. Don't</li> </ol>
<b>Noisy Pump-Cavitation (Pump Starving)</b>	<ol style="list-style-type: none"> <li>1. Damaged inlet hose</li> <li>2. Fluid viscosity too high</li> <li>3. Operation temperature too low / cold oil</li> <li>4. Excessive drive speed</li> </ol>	<ol style="list-style-type: none"> <li>1. Replace hose</li> <li>2. Replace oil - refer to oil usage</li> <li>3. Allow system to warm up</li> <li>4. Do not exceed the specified PSI</li> </ol>

Make sure shut-off valves on hydraulic tank are completely open when running the machine.

### MAINTAIN FEEDWHEEL HYDRAULIC PRESSURE AT 2100 PSI.

Follow typical hydraulic flow and relief settings on pages 50 - 52.

Follow proper hydraulic oil requirements on page 48 - 49.

**HYDRAULIC SYSTEM TROUBLE SHOOTING cont.**

**Before attempting any type of maintenance disengage clutch, install clutch lock, turn off engine, wait for the disc/drum to come to a complete stop, install the disc/drum lock pin, disconnect battery, and make sure the ignition key is in your possession!**

PROBLEM	POSSIBLE CAUSE	SOLUTION
<b>Pump Picking Up Air</b>	<ol style="list-style-type: none"> <li>1. Low oil level</li> <li>2. Loose or damaged inlet hose</li> <li>3. Aeration of fluid in reservoir</li> <li>4. Worn or damaged pump shaft or seal</li> </ol>	<ol style="list-style-type: none"> <li>1. Refill to 7/8 full</li> <li>2. Replace hose</li> <li>3. Check oil return pipes in reservoir</li> <li>4. Replace</li> </ol>
<b>Other Noises</b>	<ol style="list-style-type: none"> <li>1. Worn or damaged gears and housings</li> <li>2. Shaft misalignment</li> <li>3. Worn or faulty bearing</li> <li>4. Belt shield rubbing</li> </ol>	<ol style="list-style-type: none"> <li>1. Replace pump</li> <li>2. Realign shaft</li> <li>3. Replace bearing</li> <li>4. Tighten bolts</li> </ol>
<b>No Pressure</b>	<ol style="list-style-type: none"> <li>1. Low oil level</li> <li>2. Pump cartridge turning wrong direction</li> <li>3. Pump shaft broken</li> <li>4. Relief valve sticking</li> <li>5. Belts slipping</li> </ol>	<ol style="list-style-type: none"> <li>1. Refill to 7/8 full</li> <li>2. Reverse cartridge</li> <li>3. Replace</li> <li>4. Clean or replace</li> <li>5. Tighten or replace belts</li> </ol>
<b>Erratic Pressure</b>	<ol style="list-style-type: none"> <li>1. Contaminants in fluid</li> <li>2. Worn or sticking relief valve</li> <li>3. Pressure setting too low</li> </ol>	<ol style="list-style-type: none"> <li>1. Replace fluid</li> <li>2. Clean or replace</li> <li>3. Check and reset pressure at relief correctly</li> </ol>
<b>Solenoid Valve Not Working</b>	<ol style="list-style-type: none"> <li>1. Faulty pump</li> <li>2. Directional control shifting</li> <li>3. Spool not shifting</li> <li>4. Spool binding</li> <li>5. Loose wires</li> </ol>	<ol style="list-style-type: none"> <li>1. See additional pump info.</li> <li>2. Check voltage to solenoid coils</li> <li>3. Check internal pilot pressure for sticking</li> <li>4. Remove and clean</li> <li>5. Check and repair</li> </ol>
<b>Slow or Erratic Operation</b>	<ol style="list-style-type: none"> <li>1. Air in fluid</li> <li>2. Low fluid level</li> <li>3. Viscosity of fluid too high</li> <li>4. Internal leakage through solenoid or manual valve</li> <li>5. Worn pump</li> <li>6. Pump RPM too slow</li> <li>7. Pump belt too loose</li> </ol>	<ol style="list-style-type: none"> <li>1. See info. on pump</li> <li>2. Refill to 7/8 full</li> <li>3. Use recommended hydraulic oil</li> <li>4. Replace with new valves</li> <li>5. Replace pump</li> <li>6. See pump info.</li> <li>7. Tighten or replace</li> </ol>
<b>Overheating of System Under Continuous Operation at Relief Setting</b>	<ol style="list-style-type: none"> <li>1. Stalling under load, etc.</li> <li>2. Fluid viscosity too high</li> <li>3. Collapsed hose</li> </ol>	<ol style="list-style-type: none"> <li>1. Readjust relief setting if necessary</li> <li>2. Use recommended hydraulic oil</li> <li>3. Locate, repair or replace</li> </ol>
<b>Excessive Slippage or Internal Leakage</b>	<ol style="list-style-type: none"> <li>1. Check stall leakage past motors</li> <li>2. Fluid viscosity too low</li> </ol>	<ol style="list-style-type: none"> <li>1. Repair or replace motor check pump with flow meter</li> <li>2. Replace with recommended oil</li> </ol>

Make sure shut-off valves on hydraulic tank are completely open when running the machine.

**MAINTAIN FEEDWHEEL HYDRAULIC PRESSURE AT 2100 PSI.**

Follow typical hydraulic flow and relief settings on pages 50 - 52.

Follow proper hydraulic oil requirements on page 48 - 49.

**Bandit**

## CORRECTING HYDRAULIC PROBLEMS

**Before attempting any type of maintenance disengage clutch, install clutch lock, turn off engine, wait for the disc/drum to come to a complete stop, install the disc/drum lock pin, disconnect battery, and make sure the ignition key is in your possession!**

COMPONENT	PROCEDURE
<b>Checking relief valve setting</b>	Refer to the hydraulic pressure adjustment procedure section of the manual to find the correct procedure for checking relief valve setting. (pgs. 50 - 52)
<b>Adjusting relief valve setting</b>	Refer to the hydraulic pressure adjustment procedure section of the manual to find the correct procedure for adjusting relief valve pressure settings. (pgs. 50 - 52)
<b>Cleaning relief valve</b>	1. See page 50 on how to clean a relief valve.
<b>Checking for defective pump</b>	1. See pages 56 - 57 on how to check a hydraulic pump.
<b>Checking for defective motor</b>	<ol style="list-style-type: none"> <li>1. If everything checks out as correct, it may be time to check the hydraulic motor.</li> <li>2. If your machine has Live Hydraulics, see page 58 on how to check a hydraulic motor.</li> <li>3. If your machine does not have Live Hydraulics, contact your local dealer or Bandit Industries for instructions.</li> </ol>

**NOTE:** When returning hydraulic components for warranty make sure to box up all warranted parts to avoid additional damage while shipping. **Do not disassemble any hydraulic components which are to be warranted.** Anything which has been disassembled or tampered with will not be warranted. Items being returned must be clean. All hydraulic components must have all hosing ports plugged. Failure to plug ports will allow debris to enter components which will void warranty.

### MAINTAIN FEEDWHEEL HYDRAULIC PRESSURE AT 2100 P.S.I.

Follow typical hydraulic flow and relief settings on pages 50 - 52.

Follow proper hydraulic oil requirements on page 48 - 49.

# HYDRAULIC PUMP CHECK OUT

## HYDRAULIC PUMP CHECK OUT WITHOUT USING A FLOW METER

To check out the hydraulic pump the mechanic will need a needle type flow control valve, a pressure gauge capable of reading 3000 p.s.i. and a long enough hose that will span between the pump and the hydraulic tank.

- 1) Attach a Tee fitting to the discharge outlet on the pump and insert the pressure gauge to the fitting.
- 2) Attach the hydraulic flow control valve to the fitting and the hose to the outlet port of the flow control valve.
- 3) **Make sure the pressure gauge is installed up stream from the flow control valve.**  
**Failure to do this will cause serious damage to the hydraulic pump when testing.**
- 4) Remove any inlet screen from underneath the hydraulic oil tank fill inlet and place the open end of the hose into the tank oil fill inlet.
- 5) **MAKE SURE THAT THE FLOW CONTROL VALVE IS FULLY OPEN SO AS TO ALLOW UNRESTRICTED FLOW TO PASS THROUGH IT.**
- 6) Start the engine and engage the pump.
- 7) Have a second person lift the hydraulic hose far enough out of the tank inlet to observe the flow of oil going onto the tank. Observe the pressure gauge reading to make sure a high pressure does not exist.
- 8) Increase the engine speed slowly to full rpm and at the same time observe the pressure. This should still remain low.
- 9) **SLOWLY** turn the needle valve on the flow control in and observe the pressure increase on the pressure gauge.
- 10) Continue closing the flow control valve until the pressure gauge reading reaches 90% of the normal relief valve setting. **Never allow the pressure to go more than 90% of the main relief pressure.**
- 11) If the pump is good there should be no noticeable decrease in the flow rate coming out of the hose and into the hydraulic tank.
- 12) If 90% of the main relief pressure can not be obtained and/or the flow rate of the hose is considerably less, then the pump is worn or damaged.

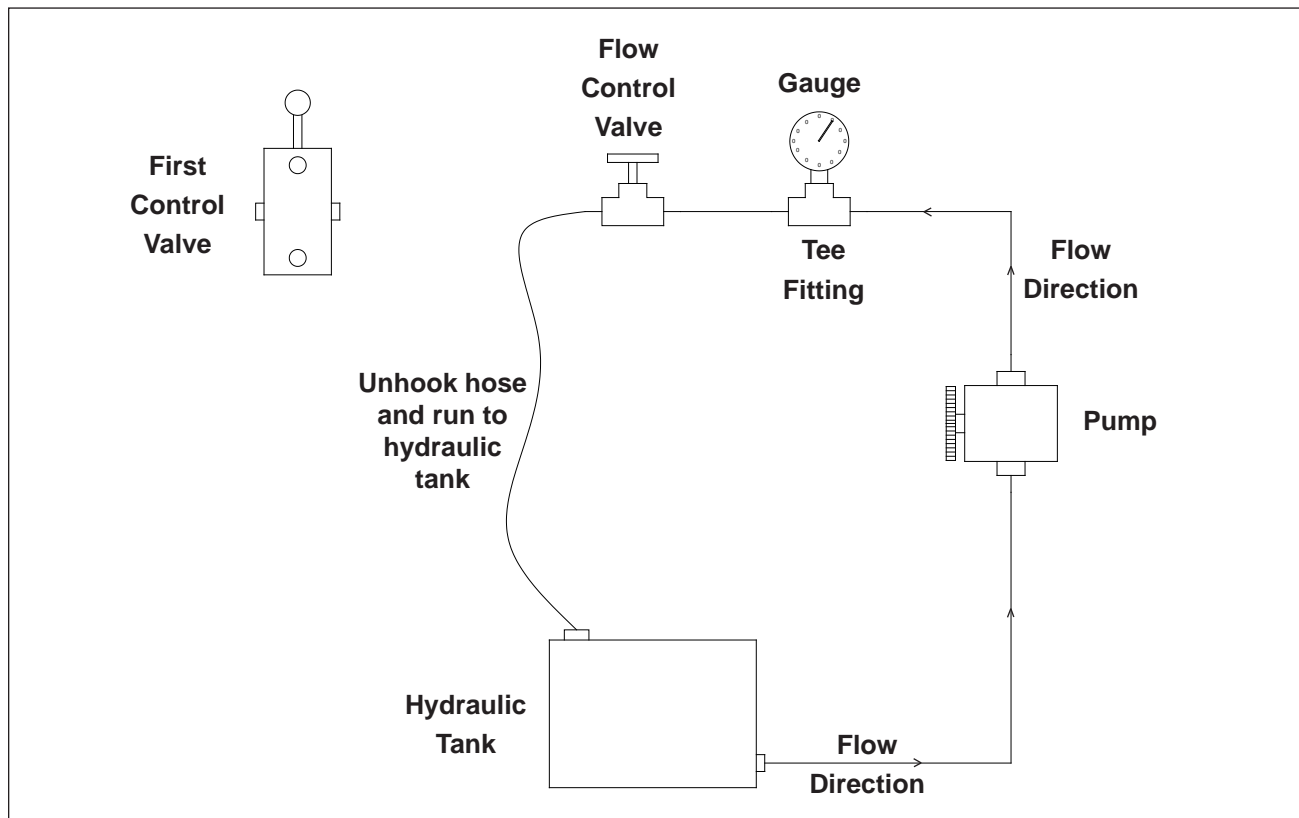

# HYDRAULIC PUMP CHECK OUT

## HYDRAULIC PUMP CHECK OUT USING A FLOW METER

To check out the hydraulic pump the mechanic will need a pressure gauge capable of reading 3000 p.s.i. and a needle type flow valve.

- 1) Disconnect the pump outlet hose from the pump.
- 2) Attach a Tee fitting to the discharge outlet on the pump and insert the pressure gauge to the fitting.
- 3) Attach the flow meter to the tee fitting and the flow control valve to the flow meter.
- 4) Reattach the pump pressure outlet hose to the flow control valve.
- 5) **Make sure the pressure gauge is installed up stream from the flow control valve. Failure to do this will cause serious damage to the hydraulic pump when testing.**
- 6) **MAKE SURE THAT THE FLOW CONTROL VALVE IS FULLY OPEN SO AS TO ALLOW UNRESTRICTED FLOW TO PASS THROUGH IT.**
- 7) Start the engine and engage the pump.
- 8) Observe the flow rate through the meter and pressure gauge reading to make sure a high pressure does not exist.
- 9) Increase the engine speed slowly to full rpm and at the same time observe the pressure and flow rate. The pressure should still remain low. Make a note of the flow rate (gpm) at full engine rpm.
- 10) **SLOWLY** turn the needle valve on the flow control in and observe the pressure increase on the pressure gauge.
- 11) Continue closing the flow control valve until the pressure gauge reading reaches 90% of the normal relief valve setting. **Never allow the pressure to go more than 90% of the main relief pressure.**
- 12) If the pump is good, you should have at least 80% of the flow rate (gpm) passing through the flow meter as noted at low pressure.
- 13) If 90% of the main relief pressure can not be obtained and/or the flow rate passing through the meter is considerably less, then the pump is worn or damaged.

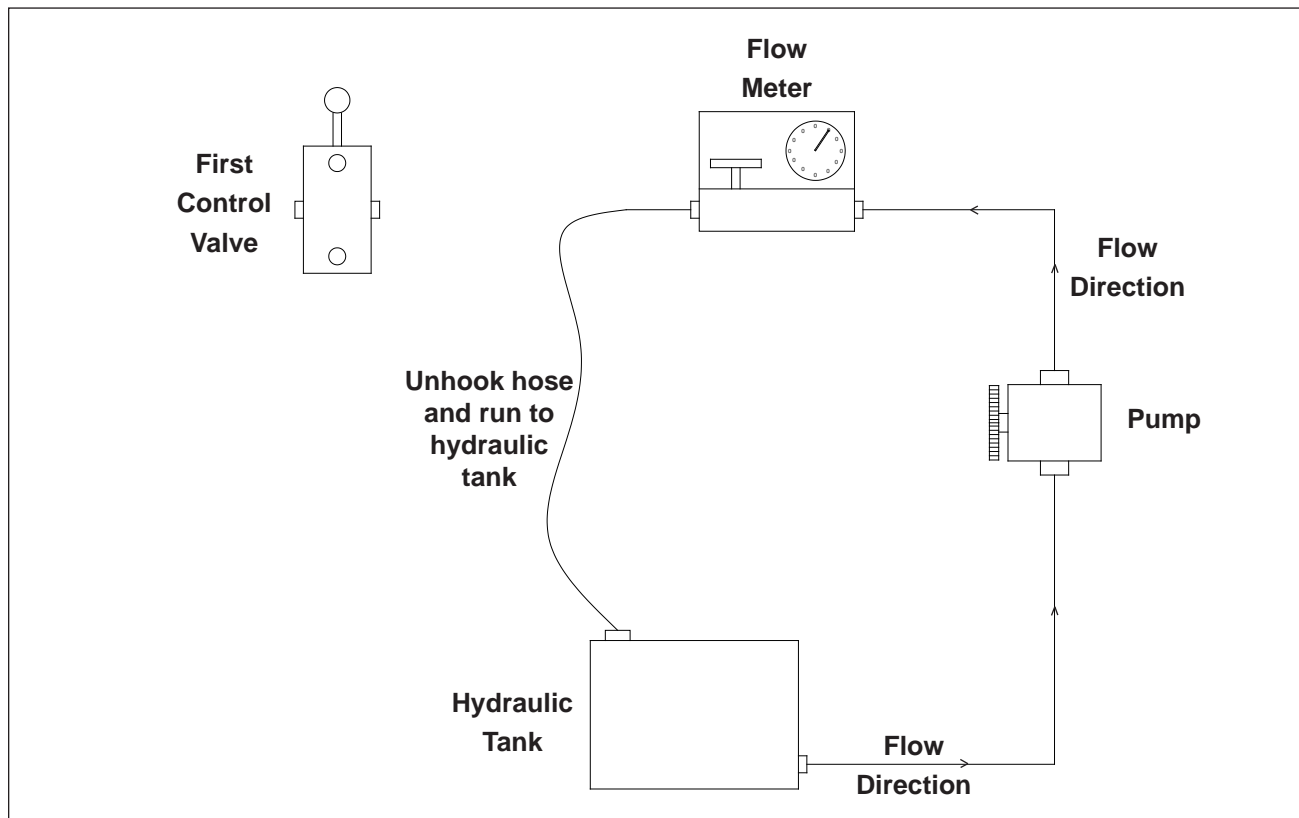

# HYDRAULIC MOTOR CHECK OUT

## HYDRAULIC MOTOR CHECK OUT FOR MACHINES WITH LIVE HYDRAULICS

To check out a hydraulic motor the mechanic will need a pressure gauge capable of reading 3000 p.s.i., a Tee fitting to install in the control valve, a plug fitting to install in the control valve and a clean 5 gallon pail.

- 1) The following instructions are for machines with Live Hydraulics, for machines without Live Hydraulics contact your local dealer or Bandit Industries.
- 2) In order to check out a hydraulic motor, it is necessary to mechanically stop the motor from turning while under load. The hydraulic pump needs to be driven without turning the chipper disc/drum (Live Hydraulics). Feed a reasonably large size log into the machine until it contacts the stationary disc/drum. This should stall the hydraulic motor(s). It may also be necessary to apply down pressure by operating the yoke control valve (if equipped).
- 3) With the feedwheel(s) mechanically locked as described and the engine turned off, unhook the hose going from the hydraulic motor back to the control valve at the valve. Some machines will be equipped with a flow divider between the hydraulic motor and the control valve.
- 4) Place the end of the hose in a clean 5 gallon pail.
- 5) Plug the open port in the control valve.
- 6) Unhook the other hose in the control valve and install a Tee fitting into the control valve and attach the hose to the Tee fitting.
- 7) Install a pressure gauge in the other port in the Tee fitting to monitor hydraulic pressure.
- 8) Put the infeed control valve in the center position and start the engine.
- 9) Increase the engine speed slowly to full rpm.
- 10) Operate the infeed control valve to feed the log into the stationary disc/drum. If the feedwheel(s) try to turn, apply down pressure by using the yoke control valve (if equipped).
- 11) Providing the pump and the relief are functioning properly, the pressure gauge should read the specified main relief setting, see page 51.
- 12) Observe the amount of hydraulic fluid coming from the hose into the pail. The amount of leakage should not be more than about 1 g.p.m. into the pail.

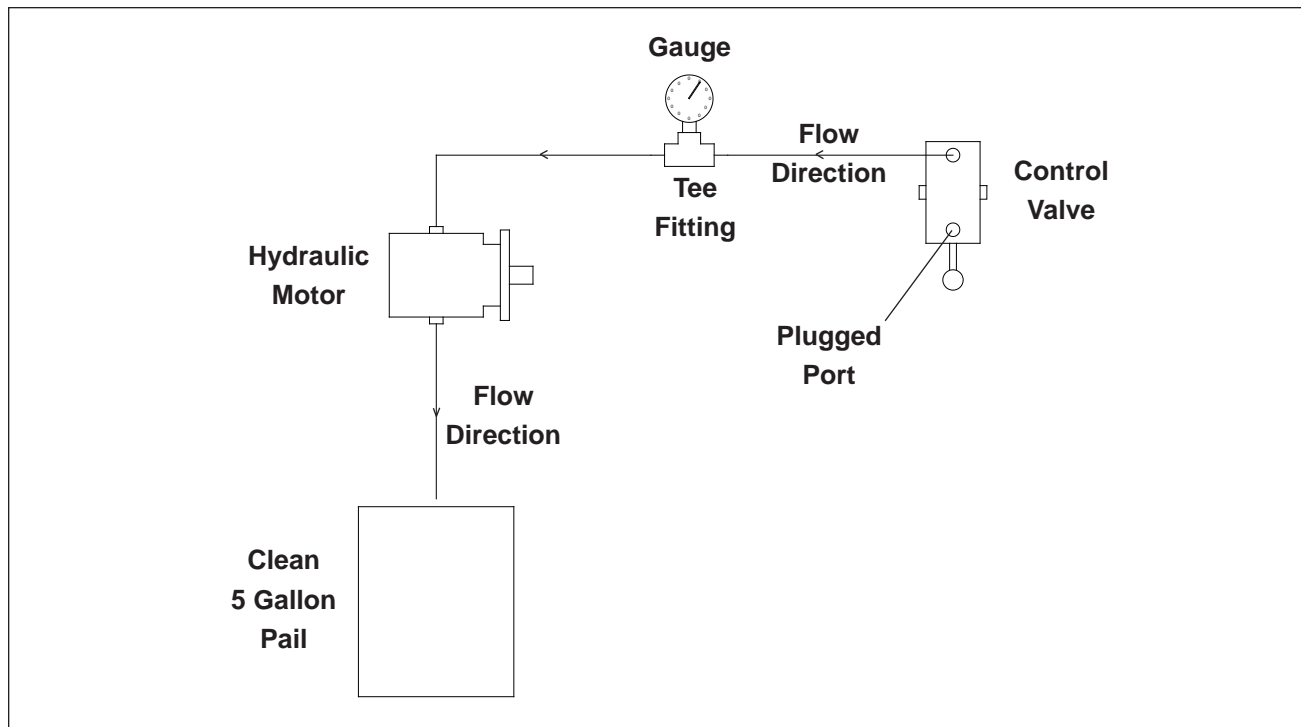

# TRAILERIZED HYDRAULIC SCHEMATIC

SPECIFIC SCHEMATIC FUNCTION MAY VARY DEPENDING ON OPTIONS OR COMPONENT MANUFACTURE.

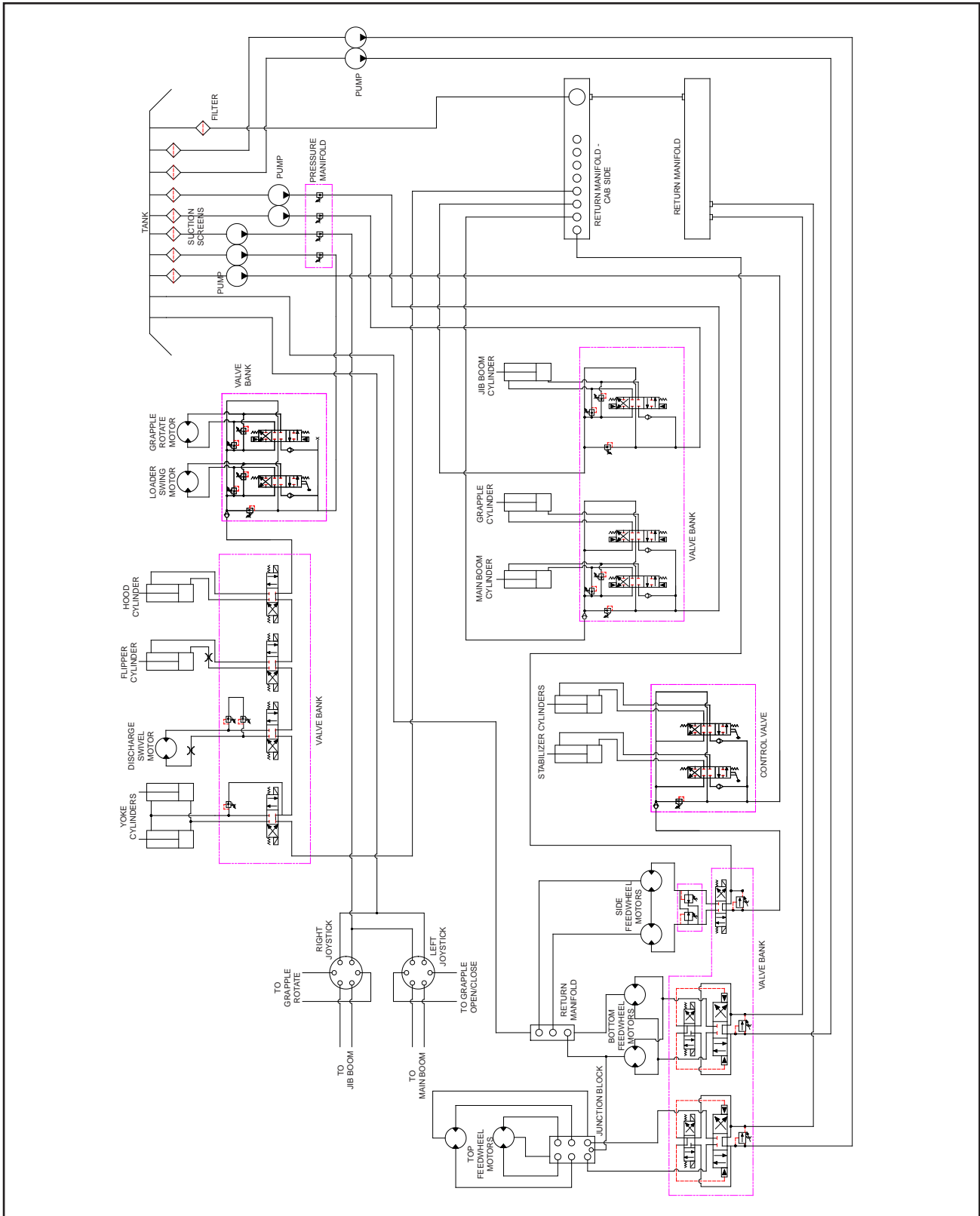

# TRACK HYDRAULIC SCHEMATIC

SPECIFIC SCHEMATIC FUNCTION MAY VARY DEPENDING ON OPTIONS OR COMPONENT MANUFACTURE.

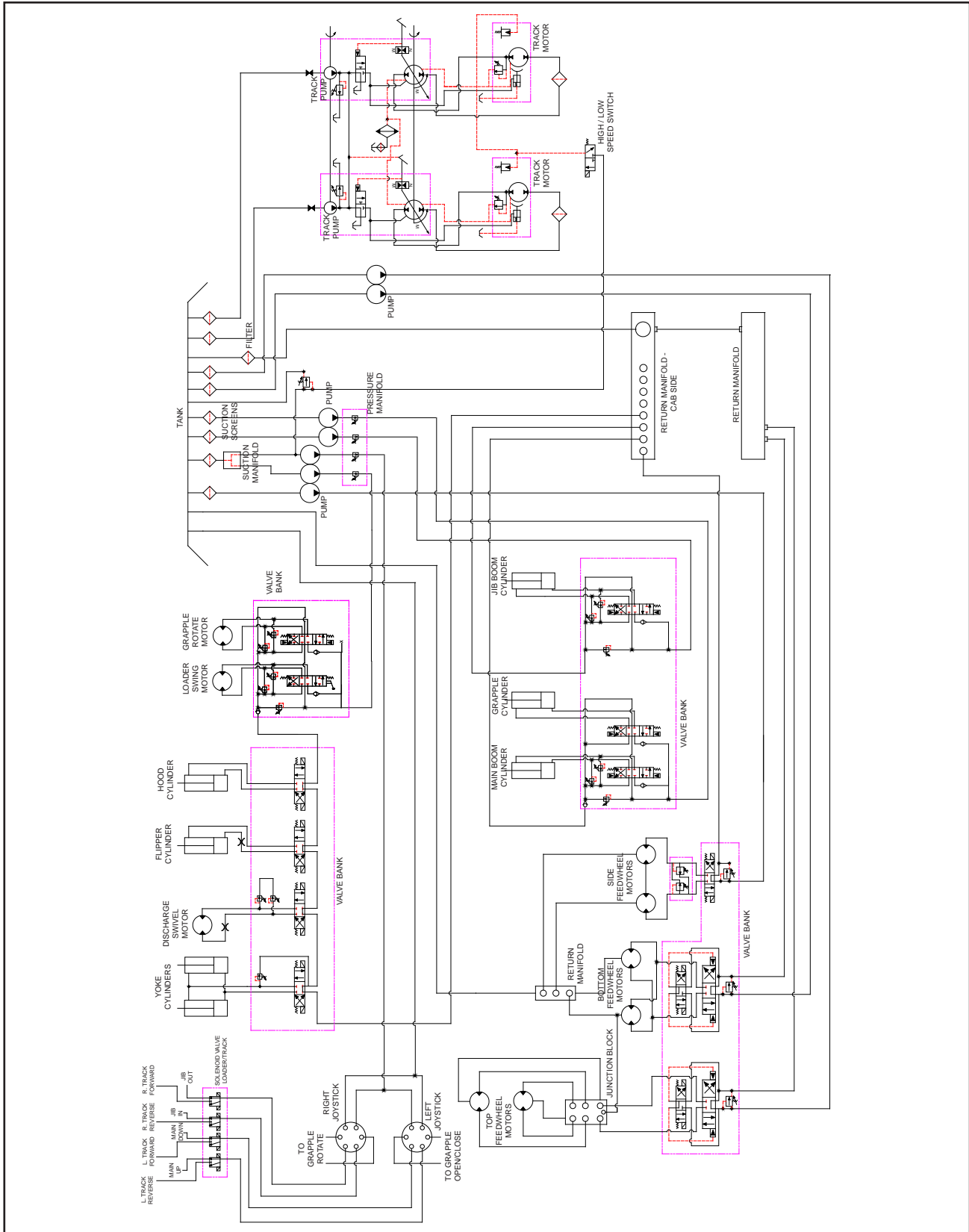

# CHIPPER SECTION

Knives should be replaced in sets. These sets are determined by the amount of resharpening done to the knives. It should be reinstalled with another knife of comparable usage. It helps to keep the disc/drum balanced, and it helps maintain chip quality. **NEVER** allow these knives to wear beyond absolute specified minimum distance.

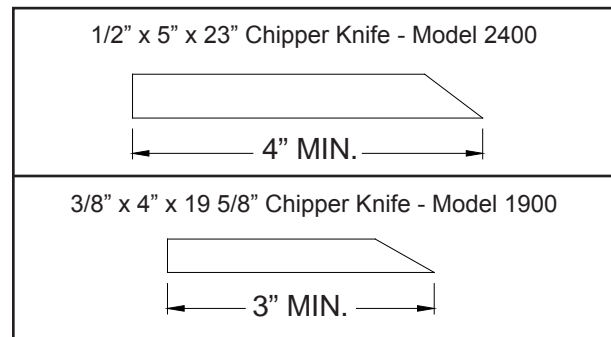

## TROUBLE SHOOTING CHIPPER PROBLEMS

### 1) Chipper Makes Poor Quality Chips or Does Not Feed Properly.

- A. Knives have lost their edge. File, grind or replace knives. **DO NOT** operate the Bandit with dull knives.
- B. Knife anvil worn or needs adjustment. Rotate or replace.
- C. Feedwheel is not operating correctly. (SEE HYDRAULIC TROUBLE SHOOTING).
- D. The throat/base opening is a high-wear area. The feed plate anvil takes much of this wear but other areas wear as well. Attention must be paid to any areas where outer, noncutting edges of chipper knife are exposed. These areas must be built up with weld to maintain the original integrity.
- E. Knives are at the wrong angle. Knives must be ground at a  $29\ 1/2^\circ$  to  $30^\circ$  angle.
- F. Feedwheel teeth worn (REPLACE).
- G. Material being chipped is very small, dry or rotting. This type of material does not produce good chip quality.

### 2) Chipper Knife Hits Anvil.

- A. Check the anvil clearance at both sides of the knife by using a feeler gauge, the clearance should be approximately .060 to .080 from the highest knife.
- B. Check the chipper bearing bolts for tightness (SEE TORQUE CHART).

### 3) Discharge Plugs or Does Not Throw Chips Properly.

- A. Lugging engine on large material - keep engine RPM up.
- B. Knives are dull or worn to minimum size.
- C. Obstruction in discharge chute. Patches welded into the chute can cause obstruction of chip flow. Anything causing an obstruction will cause the chute to plug.
- D. Chipping rotting material that has little substance can also plug the discharge chute.
- E. Worn fan blades.

### 4) Chipper Bearings Running Too Hot.

- A. Improper lubrication-grease bearings once a day with EP-2 Lithium type grease.
- B. Chipper disc operating at too high RPM's. **DO NOT** exceed recommended RPM's.
- C. Bearings worn out (REPLACE).
- D. Locknut on sheave side bearing is loose.

# CHIPPER SECTION

## TROUBLE SHOOTING CHIPPER PROBLEMS

PROBLEM	POSSIBLE CAUSE	SOLUTION
Chips Too Big	<ol style="list-style-type: none"> <li>1. Counter knives worn</li> <li>2. Chipper disc speed too slow</li> <li>3. Worn knife anvil</li> <li>4. Chipper infeed hopper worn</li> </ol>	<ol style="list-style-type: none"> <li>1. Replace counter knives.</li> <li>2. Chipper RPM with no load should be as specified below.</li> <li>3. Replace or rotate.</li> <li>4. Build up with weld or hard surface material, replace.</li> </ol>
Chips Too Fine	<ol style="list-style-type: none"> <li>1. Dull knives</li> <li>2. Anvil clearance too close</li> <li>3. Obstruction in discharge chute or chipper base</li> <li>4. Feed rate too slow</li> <li>5. Excessive disc speed</li> <li>6. Damaged knife anvil</li> <li>7. Feeding small wood</li> </ol>	<ol style="list-style-type: none"> <li>1. Replace with sharp knives.</li> <li>2. Clearance should be .060 to .080.</li> <li>3. Remove obstruction.</li> <li>4. Increase feed rate.</li> <li>5. Disc should not exceed specified RPM.</li> <li>6. Replace or rotate.</li> <li>7. Small braches and twigs can not produce good sized chips.</li> </ol>
Chipper Feeding Poorly	<ol style="list-style-type: none"> <li>1. Anvil clearance too close</li> <li>2. Improper knife angle</li> <li>3. Wood extremely dirty or dry</li> <li>4. Wood extremely hard or frozen</li> <li>5. Poor quality chipper knives</li> <li>6. Dull chipper knives</li> <li>7. Chipper RPM's too slow</li> </ol>	<ol style="list-style-type: none"> <li>1. Check anvil setting. Clearance should be .060 to .080.</li> <li>2. Check knife angle. Maintain knives at an angle of 29 1/2° to 30°.</li> <li>3. Caused by seasonal conditions which can not be avoided.</li> <li>4. Same as 3.</li> <li>5. Replace chipper knives.</li> <li>6. Replace chipper knives, never attempt to chip with dull knives.</li> <li>7. Chipper RPM with no load should be as specified below.</li> </ol>
Wood Packing Between Knife and Counter Knife	<ol style="list-style-type: none"> <li>1. Counter knives excessively worn</li> <li>2. Clamps not properly tightened</li> <li>3. Hardware not properly seated due to foreign material in pocket</li> <li>4. Worpded or worn pocket hardware</li> </ol>	<ol style="list-style-type: none"> <li>1. Check counter knife wear. When knives are worn, wood will pack between counter knife and chipper knife, usually ruining hardware.</li> <li>2. Tighten to 500 ft.-lbs.</li> <li>3. Always clean knife pocket thoroughly when changing knives.</li> <li>4. If the steel pockets parts are worpded, damaged, or worn they will not properly clamp and hold together.</li> </ol>
Chipper Disc Moving Sideways	<ol style="list-style-type: none"> <li>1. Loose draw ring</li> <li>2. Loose shaft</li> </ol>	<ol style="list-style-type: none"> <li>1. Tighten draw ring, aligning disc as you retighten. Check alignment with dial indicator holding within .005 of high knife.</li> <li>2. Check to make sure that shaft is not sliding in bearings, or that bearing bolts are not loose. Check tightness of retainer bolt on front bearing and lock nut on rear bearing.</li> </ol>

**NOTE:** Model 1900 Chipper Disc - 737 RPM  
 Model 2400 Chipper Disc - 594 RPM

# KNIFE GRINDING AND FILING

Only Bandit knives and hardware are recommended for use in your Bandit chippers. Only then can you be assured of a quality product that fits and performs the best to the standards of excellence that is expected from the Bandit chipper.

Chipper knives **MUST** be kept sharp at all times for the ultimate chipper and knife performance. The main cause of poor cutting performance is dull knives.

**Dull Knives Cause:**

- Excessive waste of engine horsepower
- Bad quality chips; chunks, slivers, etc.
- Excessive strain on knives and knife mounting hardware
- Excessive strain on chipper disc/drum bearings and total machine
- Excessive chipping vibration damaging the machine
- Excessive strain on drives, PTO's, engines, etc.
- Increases the probability of the discharge plugging and decreases the throwing distance
- Loss of time and money

**The Dulling Of Chipper Knives Is Caused By:**

- Poor quality knives
- Improper anvil to knife clearance
- Force feeding wood faster than chipper will accept
- Dirt, grit, or foreign material on the wood
- Chipper knives ground at wrong angle
- Improper care of knives and knife hardware

These are just a few factors, there are other situations that can lead to the dulling of chipper knives.

**NOTICE**

Many times a chipper knives cutting edge/point can be brought back to a good edge with a #10 Flat Bastard Mill File. This can reduce the amount of regrinding.

Typical Knife Grinding Angles:

“Bolt-In” Knives = 29 1/2° to 30° Angle

Knives should be replaced in sets. These sets are determined by the amount of resharping done to the knives (knife width). Regrinding knives reduces the width of the knife. Knife replacement should be done in sets of the same width knives. That will reduce chipping vibration and increase chipping performance.

**NOTICE**

- Keep knives sharp.
- Keep knife angle correct when grinding.
- Do not over grind so knife is narrower than allowed width, or you will pack wood and break knives.
- Use correct knife size, knife quality, knife mounting hardware, and torque knife mounting hardware to the specified torque.
- Replace knife mounting hardware after (5) times of tightening.

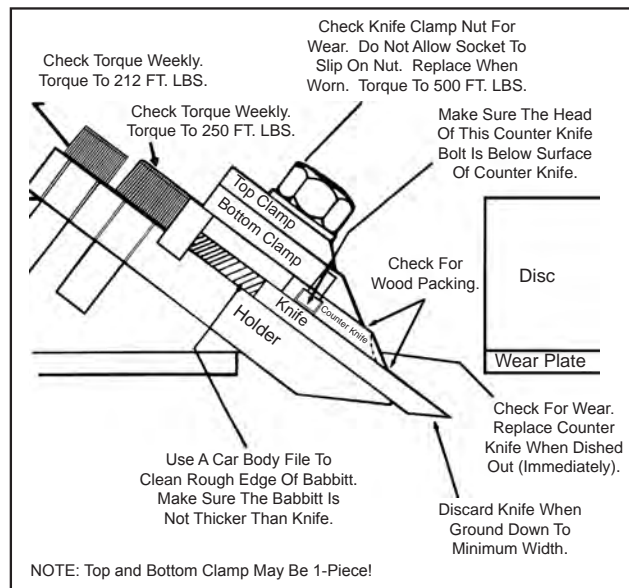

# CHIPPER SECTION

## “CLAMP-IN” KNIFE HARDWARE

**⚠ DANGER**

Replace the bolts, nuts, knives, counter knives, clamps and holder when they need it. DON'T stretch it! You will pay for it either by damage to machine or possible damage to a person. Knife pocket nuts and bolts should be replaced after (5) uses.

Using a piece of wood and a screwdriver install the sharp babbitted knife and hold it firmly into position. The piece of wood will hold the knife back into pocket and the screwdriver must be used to raise the knife to the outer edge of pocket.

To retighten the knife clamp; first tighten center nut on clamp and then tighten the outside nuts. Clamp nuts must be torqued tight at 500 ft.-lbs.

Always check with a .002 to .005 feeler gauge to make sure the knife, counter knife and clamps are seated tight at all seams when done. There should not be any gap between the knife pocket pinch points in hardware.

When changing “clamp-in” knives it is a must that one person be on each side of chipper disc to change knives.

To remove the dull knife have one person hold the knife in position carefully with leather gloves from infeed side of disc. Then the other person from engine side of disc can loosen the clamp nuts with a 6-point socket. They only need to be loosened enough to let knife slide out infeed side of chipper disc. Clean all debris out of the knife slot in hardware. Always visually check the counter knife for replacement wear.

## KNIFE BABBITTING PROCEDURES

Insert the knives into the knife gauge and slide the spacers up tight to avoid overspill of the babbitt material.

Heat the knife and knife gauge with a torch. This will prevent blow back which could occur if there were any moisture left in the fixture.

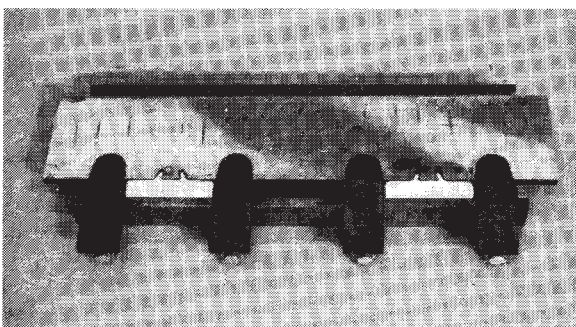
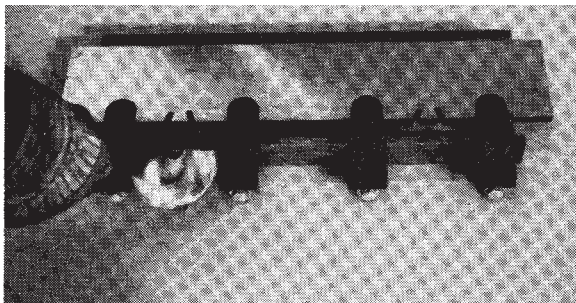

Pour babbitt slowly from the ladle on to knife gauge between steps gradually filling the cavity.

Once the babbitt has cooled remove the knife and place on a stand so the access babbitt can be filed away. Do not allow the babbitt to extend over the edges of the knife or serious damage will result to the components in the knife pocket.

“PROPER” USE OF BABBITT ON CHIPPER KNIVES

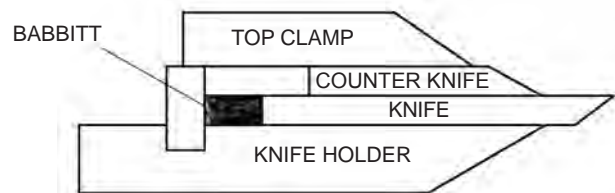

“IMPROPER” USE OF BABBITT ON CHIPPER KNIVES

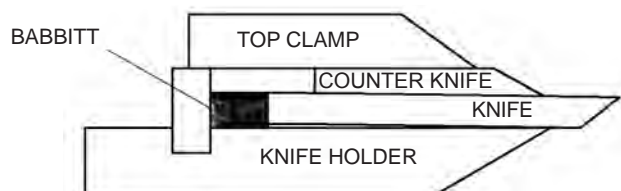

**Bandit**

---

## LUBRICATION & COOLANT

**1) Engine:**

Follow original equipment manufacturer's requirements for both changing oils and filters, refer to engine manual specifications.

**2) Engine Coolant:**

Refer to engine manufacturer's manual specifications.

**3) Clutch:**

Follow original equipment manufacturer's requirements for both greasing and adjusting. Frequently, adjust and lubricate per PTO manufacturer's manual.

**4) Hydraulic Clutch (if applicable):**

See page 48 for hydraulic clutch fluid requirements. Refer to clutch manufacturer's manual for the specific fluid level to maintain and hydraulic clutch fluid requirements.

**5) Wheel Bearings (if equipped):**

Follow axle manufacturer's requirements for lubricating wheel bearings.

**6) Tracks (if equipped):**

Follow track manufacturer's requirements for specific track lubricating procedures.

**7) Hydraulic Reservoir Tank:**

Completely change hydraulic oil, suction screen(s), and flush the tank annually. Change hydraulic oil filter AFTER FIRST 10 HOURS OF OPERATION. Then change hydraulic oil filter(s) every 400 hours or 3 months thereafter. Maintain hydraulic oil level 7/8 full. See hydraulic oil requirements below. Check hydraulic oil level in tank daily.

**8) Hydraulic Fluid Requirements:**

See pages 48 - 49 for hydraulic fluid requirements.

**9) Discharge Swivel:**

Grease swivel plates for discharge as needed.

**10) Hood Hinge:**

Make sure the hood hinge operates correctly, and is lubricated. Must replace hinge if damaged.

**11) Pivoting And Hinged Areas:**

Lubricate all pivoting and hinged areas weekly. (i.e. cabinet doors, discharge flipper, etc.)

**12) Pintle Eye Ring:**

Keep greased to reduce wear and extend the normal life of your pintle eye ring.

**13) Chain Operated Components:**

Use a dry lubricant on any chain driven components weekly. (i.e. hydraulic swivel discharge, or chain driven feedwheels).

**14) Chipper & Feedwheel Bearings:**

Use an EP-2 Lithium type grease only for all bearings. Purge chipper bearings with grease you can not over grease these bearings. Grease feedwheel bearings with one shot of grease. Both types of bearings are designed with a relief system that will not allow over greasing. In other words, you can not hurt the bearing seals by pumping in too much grease. Wipe off excess grease. **Excessive grease will attract dirt.**

Most of the failures related to bearings are diagnosed as "Contamination". Contamination is caused by improper lubrication.

Especially important is proper lubrication when the chipper is setting idle. The bearings must be fully purged when shut down. Then the bearings must be again fully purged each thirty (30) days and the machine allowed to run for approximately 10 minutes. Then fully purged again before the machine is put back into operation. Failure to do this will ruin the bearings. Bearings corrode when the machine is setting idle.

The second largest cause of bearing failure is operating them at high speeds when the grease is cold. This causes the bearing race to turn on the shaft. Naturally this ruins the bearing as well as the shaft. Allow the bearings to turn at slower speeds for at least five minutes. Also check the bearing lock collar set screws or bearing locknut for tightness each 30 days. Loose set screws or locknut allows the race to turn on the shaft. Failed bearings diagnosed as contamination or cold starts at high speed are not covered by warranty of by the bearing manufacturer.

**15) Knuckle Boom Loader (if equipped):**

Grease all pins and bushings on knuckle boom loader and grapple daily. Use 1 or 2 shots of EP-2 Lithium type grease. Wipe off excess grease. **Excessive grease will attract dirt.** NOTE: will take grease easier after the loader has been operated.

**16) Feedwheel Slide Box:**

Check that feedwheel slide box is working smoothly, oil with 10W/30 type motor oil. Especially new machines need oiling to ensure correct operation during break-in.

**17) Planetary Speed Reducer:**

Change gear lube after first 50 hours and 100 hours, then every 6 months or every 1000 hours afterwards. Requires 40 oz. of 80W/90 gear lube, keep full.

**18) Pump Bearing Block(s):**

Check and keep the fluid level in the pump bearing block(s) full weekly, use an 80W/90 type gear lube. Pack the female splines of the bearing block(s) every 6 months or every 1000 hours with an EP-2 Lithium type grease.

# TYPICAL ELECTRICAL WIRING DIAGRAMS FOR TRAILERIZED UNITS

## 6 Wire Main Cable Color Code

- Red R (Brake Light)
- White W (Ground)
- Green G (Right Turn)
- Yellow Y (Left Turn)
- Black BL (Running Lights)
- Brown BR (N/A)

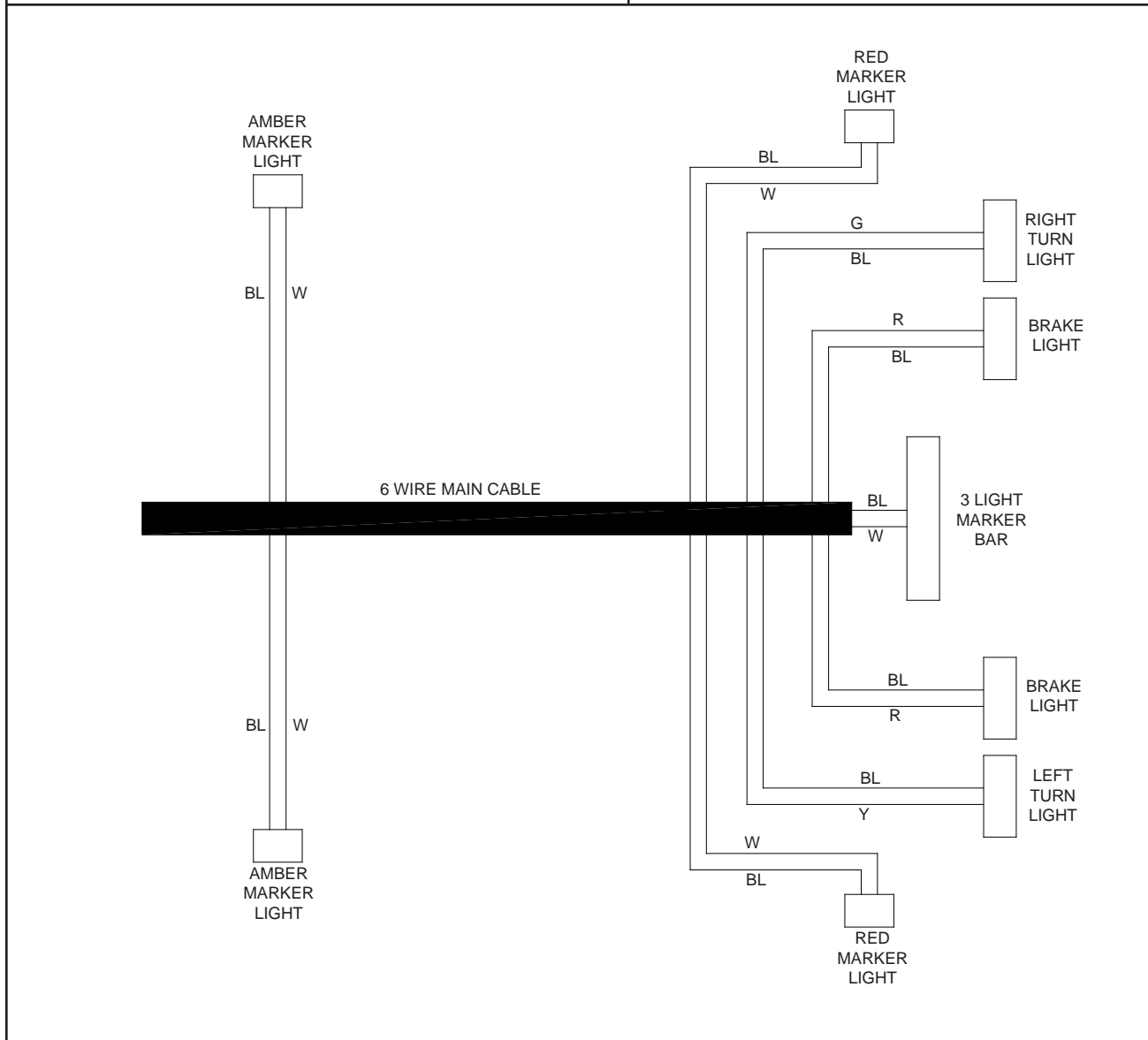
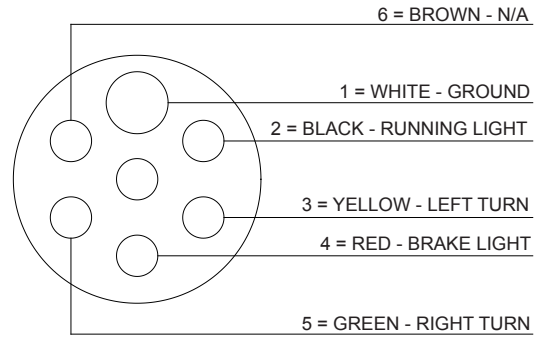

---

# REPLACEMENT PARTS SECTION

Depending on what replacement parts you are ordering the following information will be needed:

**CHIPPER COMPONENTS**

Serial Number  
Model Number of Chipper

**ENGINE COMPONENTS**

Brand  
Engine Serial Number  
Engine Spec. Number

**CLUTCH COMPONENTS**

Brand  
Serial Number  
Assembly Number of Clutch

**NOTE**

When ordering any replacement parts you should have the serial number (S/N) and model of the machine to ensure that you receive the correct replacement part. See pages 6 and 7 for typical serial number & work order number locations.

**NOTE**

All nuts, bolts, washers, and many other components can be ordered by physical description.

**NOTE**

Some of the components shown in this section are for optional equipment and may not apply to every machine.

Bandit Industries Inc. reserves the right to make changes in models, size, design, installations and applications on any part without notification.

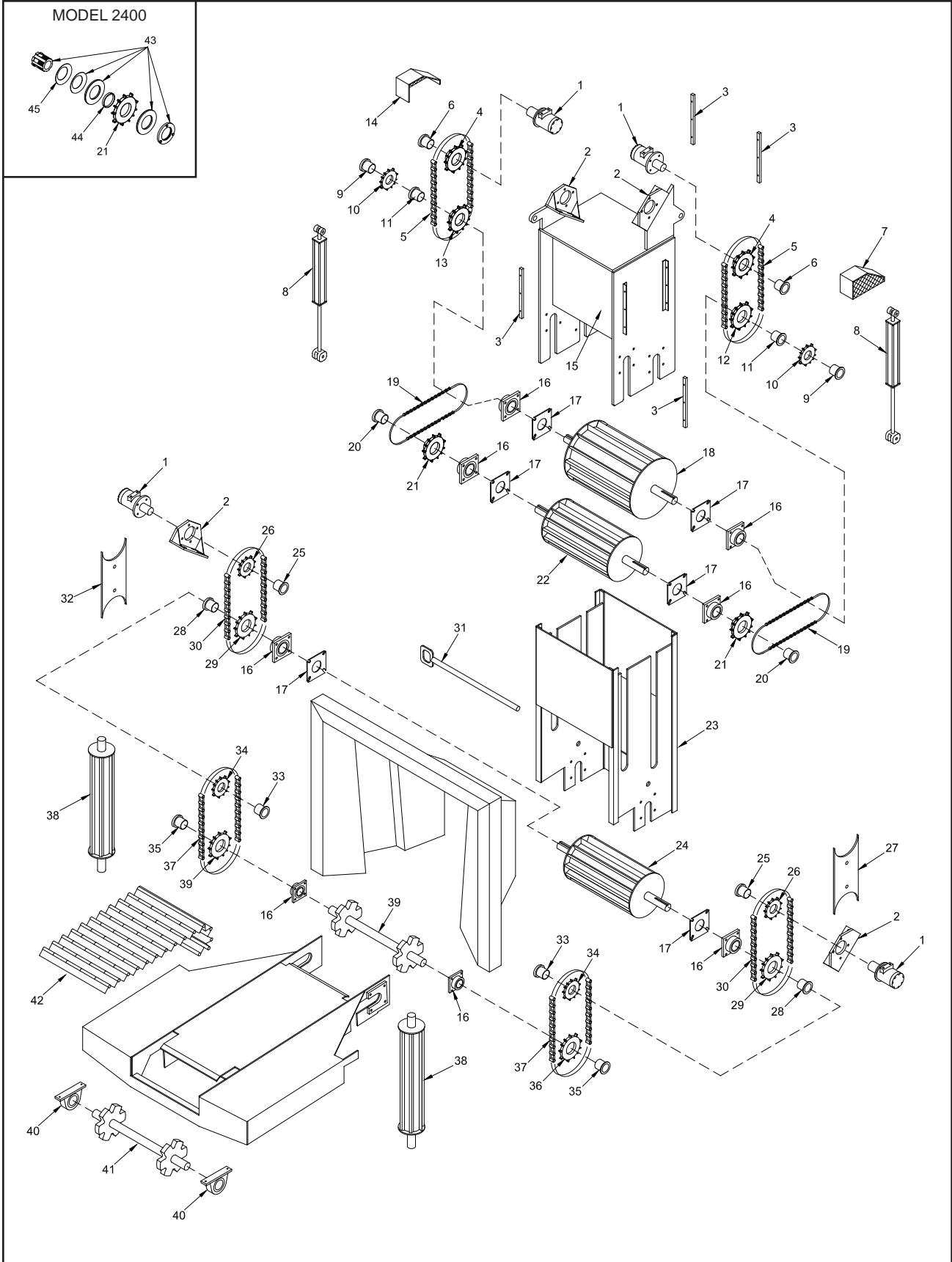

NOTE: Parts may not be exactly as shown.

**Bandit**

**MODELS 1900/2400****INFEED HOPPER COMPONENTS**

LOCATION	MODEL 1900 PART NUMBER	MODEL 2400 PART NUMBER	DESCRIPTION
1.	900-3906-29	900-3906-29	Feedwheel Hydraulic Motor
2.	975-200028	975-200028	Feedwheel Motor Mount
3.	960-200017	975-0006-18	Top Yoke Wear Slide
4.	900-1906-40	900-1906-40	Top Feedwheel Motor Sprocket
5.	900-1909-78	900-1909-78	Top Feedwheel Drive Chain
6.	900-1903-43	900-1903-43	Top Feedwheel Motor Bushing
7.	960-0502-69	975-0500-57	Right Top Feedwheel Chain Guard (Curb Side)
8.	900-3908-16	900-3902-36	Yoke Lift Cylinder
9.	N/A	900-1906-39	Climber Feedwheel Drive Bushing
10.	N/A	900-1910-09	Climber Feedwheel Drive Sprocket
11.	900-1900-08	900-1901-10	Top Feedwheel Drive Bushing
12.	900-1906-81	900-1910-51	Top Feedwheel Drive Sprocket (Double Sprocket on Mod.1900)
13.	900-1906-80	900-1910-51	Top Feedwheel Drive Sprocket
14.	960-0502-70	975-0500-58	Left Top Feedwheel Chain Guard (Road Side)
15.	960-200017	975-0500-03	Top Yoke Assembly
16 a.	900-1912-36	900-1912-36	Feedwheel & Conveyor Drive Bearing - Grip Tight Style
b.	900-1900-34	900-1900-34	Feedwheel & Conveyor Drive Bearing - Set Screw Style
17.	960-0015-09	960-0015-09	Feedwheel Bearing Backer
18.	960-0502-80	975-0500-55	Top Feedwheel Assembly
19.	900-1909-78	900-1909-78	Climber Feedwheel Drive Chain (Curb Side Only-Mod. 1900)
20.	900-1906-39	See #'s 43-45	Climber Feedwheel Driven Bushing (Curb Side Only-Mod. 1900)
21.	900-1906-80	900-1910-13	Climber Feedwheel Driven Sprocket (Curb Side Only- Mod. 1900)
22.	960-0502-92	975-0500-54	Climber Feedwheel Assembly
23.	960-200009	975-0500-04	Bottom Slide Box Assembly
24.	960-0502-79	975-0500-09	Bottom Feedwheel Assembly
25.	900-1903-43	900-1903-43	Bottom Feedwheel Motor Bushing
26.	900-1906-40	900-1906-79	Bottom Feedwheel Motor Sprocket
27.	960-0015-88	975-0005-57	Right Bottom Feedwheel Chain Guard
28.	900-1906-39	900-1906-39	Bottom Feedwheel Driven Bushing
29.	900-1906-80	900-1906-80	Bottom Feedwheel Driven Sprocket
30.	900-1909-78	900-1909-78	Bottom Feedwheel Drive Chain
31.	960-0501-73	975-0500-17	Yoke Lock Pin
32.	960-0015-89	975-0005-56	Left Bottom Feedwheel Chain Guard
33.	900-1906-39	900-1906-39	Conveyor Drive Bushing (Optional on Model 1900)
34.	900-1906-79	900-1906-79	Conveyor Drive Sprocket (Optional on Model 1900)
35.	900-1906-39	900-1906-39	Conveyor Driven Bushing (Optional on Model 1900)
36.	900-1906-94	900-1906-94	Conveyor Driven Sprocket (Optional on Model 1900)
37.	900-1909-78	900-1909-78	Conveyor Drive Chain (Optional on Model 1900)
38.	See Page 74	See Page 74	Side Feedwheel Assembly
39.	960-0503-06	975-200024	Conveyor Drive Shaft Assembly (Optional on Model 1900)
40.	900-1906-33	900-1906-33	Conveyor Idler Bearing (Optional on Model 1900)
41.	960-0502-88	975-0500-06	Conveyor Idler Shaft Assembly (Optional on Model 1900)
42 a.	960-0502-89	975-200043	Conveyor Chain Assembly (Optional on Model 1900)
b.	960-0501-47	975-200029	Conveyor Link Assembly (Optional on Model 1900)
43.	N/A	900-1910-11	Clutch For Climber Feedwheel (Model 2400)
44.	N/A	900-1910-10	Bushing For Sprocket On Climber Feedwheel (Model 2400)
45.	N/A	900-1910-12	Clutch Spring For Climber Feedwheel (Model 2400)

NOTE: One clutch spring comes with the clutch, two required.

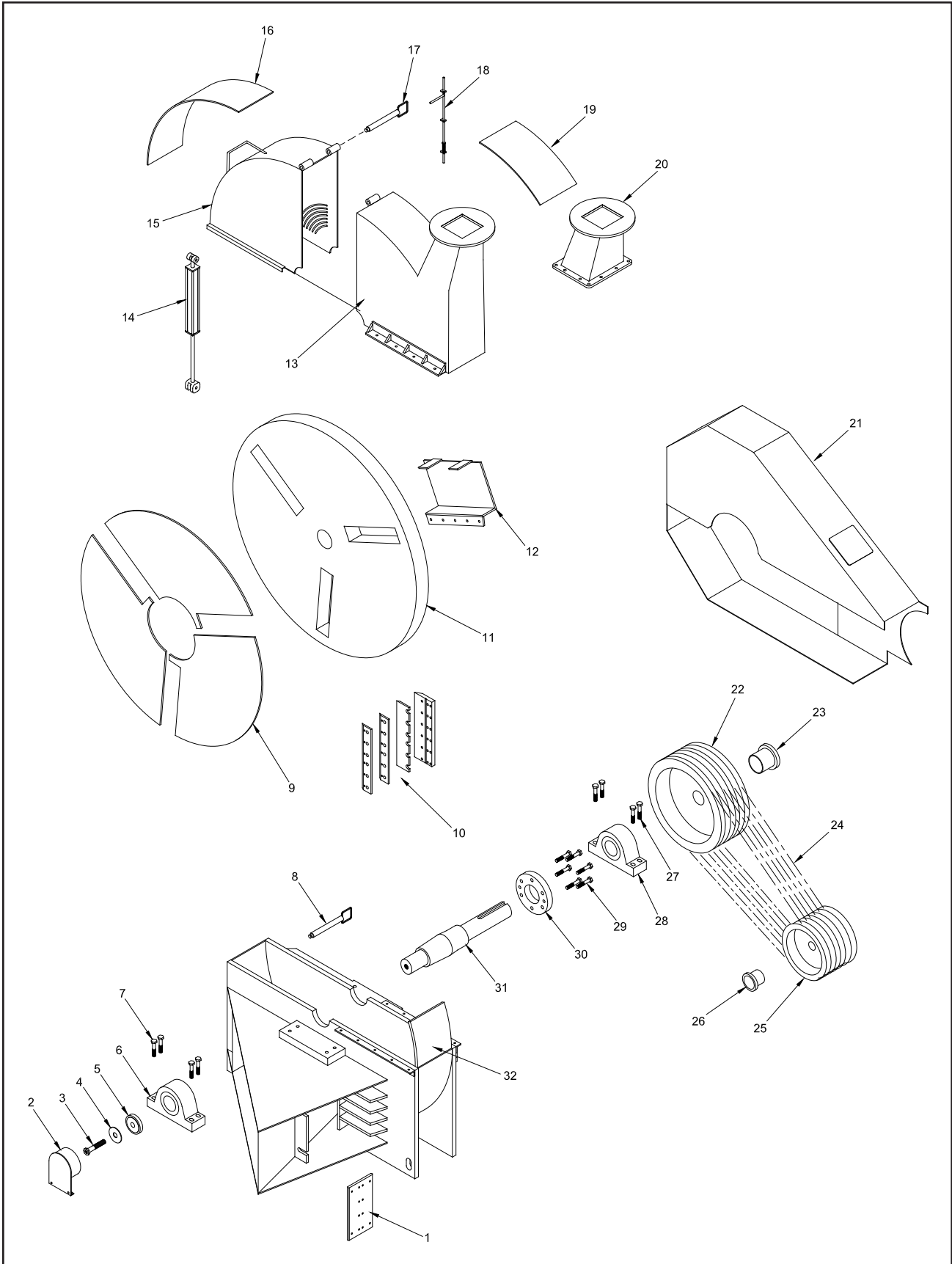

NOTE: Parts may not be exactly as shown.

**Bandit**

**MODELS 1900/2400****CHIPPER COMPONENTS**

LOCATION	MODEL 1900 PART NUMBER	MODEL 2400 PART NUMBER	DESCRIPTION
1.	See Page 73	See Page 73	Anvil
2.	960-0502-13	975-0500-11	Shaft Guard
3.	900-4904-78	900-4905-50	Bearing Retainer Bolt
4.	900-4904-77	900-4905-51	Bearing Retainer Bolt Washer
5.	960-0019-55	975-0000-55	Bearing Retainer
6.	900-1907-88	900-1906-76	Front Chipper Bearing
7.	900-3910-41	900-4907-96	Front Chipper Bearing Bolt
8.	960-0503-00	975-0500-44	Chipper Disc Lock Pin
9.	960-0016-66	975-0000-18	Wear Plate
10.	See Page 72	See Page 72	Knife Components
11.	960-0005-81	975-0500-02	Chipper Disc
12 a.	960-0502-28	975-200042	Fan Blade
b.	N/A	975-300151	Replaceable Wear Insert - Wide (Model 2400)
c.	N/A	975-300152	Replaceable Wear Insert - Narrow (Model 2400)
13.	960-200027	975-200025	Chipper Hood Stationary Half
14.	N/A	900-3908-16	Chipper Hood Cylinder (Model 2400 Only)
15.	960-0500-59	975-200027	Chipper Hood Hinged Half
16.	N/A	975-0007-16	Hinged Hood Insert (Model 2400 Only)
17 a.	960-0501-05	975-0500-17	Hood Pin
b.	900-4902-20	900-4902-20	Padlock For Hood Pin (Not Shown)
c.	P812	P812	Key For Padlock (Not Shown)
18.	960-0502-97	975-200056	Spring Lock For Hood Pin
19.	N/A	975-300453	Stationary Hood Insert (Model 2400 Only)
20.	960-0502-83	N/A	Bolt-On Transition (Model 1900 Only)
21.	960-200047	975-0500-13	Beltshield Assembly
22.	**	**	Chipper Sheave
23.	**	**	Chipper Bushing
24.	**	**	Chipper Belt
25.	**	**	Engine Sheave
26.	**	**	Engine Bushing
27.	900-3910-38	900-4907-97	Rear Chipper Bearing Bolt
28.	900-1907-89	900-1906-77	Rear Chipper Bearing
29.	900-4905-22	900-4907-95	Draw Ring Bolt
30.	960-0007-35	975-0002-20	Draw Ring
31.	960-0016-18	975-0002-18	Chipper Shaft
32.	960-300170	975-300038	Replaceable Belly Band

**\*\* Components vary with engine options order by physical description or machine S/N.**

**NOTE: Nuts, bolts, washers, and all other components  
can be ordered by physical description.**

**Bandit**

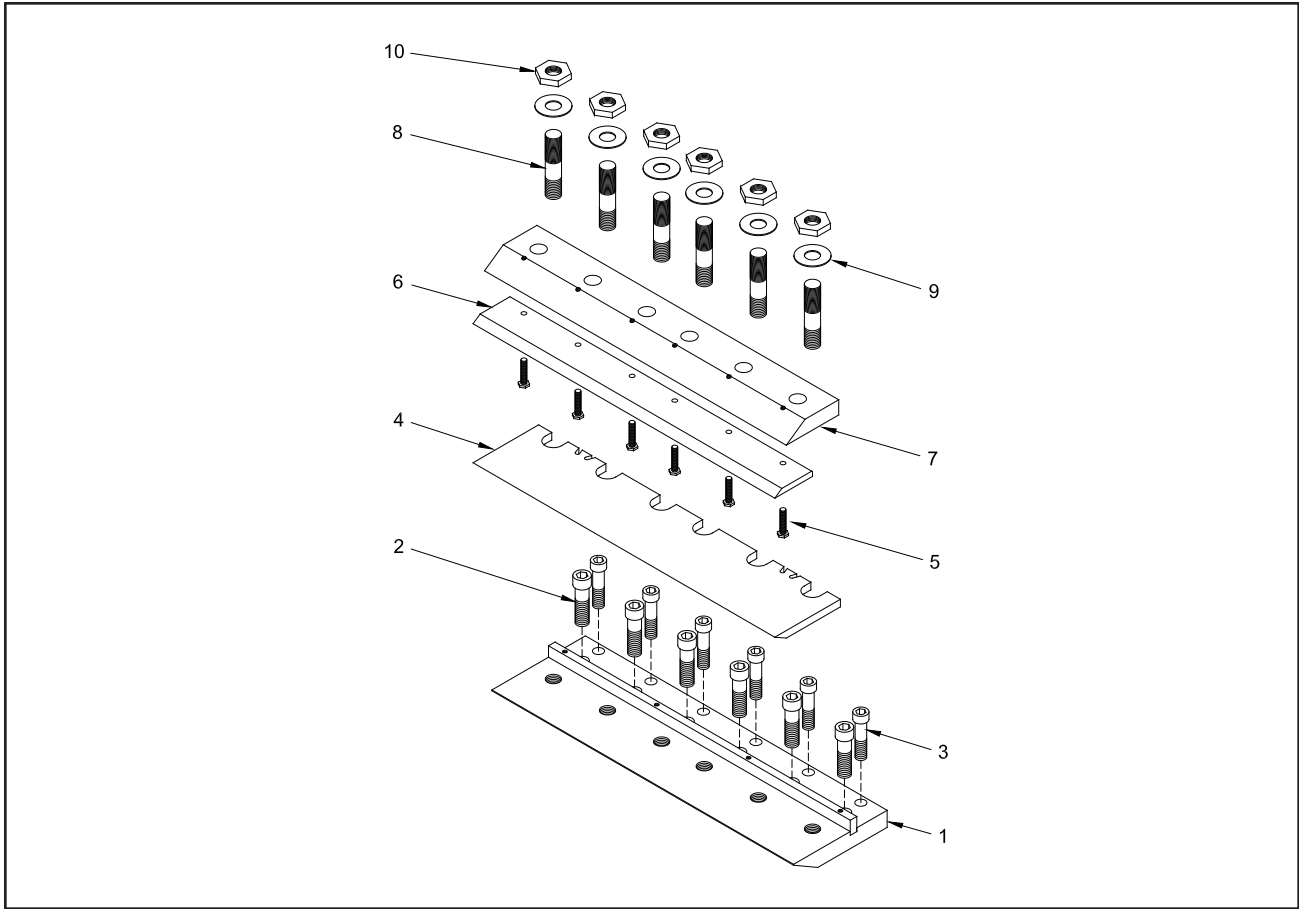

LOCATION	MODEL 1900 PART NUMBER	MODEL 2400 PART NUMBER	DESCRIPTION
1 a.	960-0006-97	975-0000-00	Knife Holder And Height Bar - 3/4" Chip
b.	960-0007-27	975-0006-14	Knife Holder And Height Bar - 7/8" & 1" Chip
2.	900-4901-85	900-4901-85	3/4" Socket Head Cap Screw
3.	900-4905-27	900-4905-27	5/8" Socket Head Cap Screw
4.	900-9900-08	900-9902-74	Chipper Knife
5.	900-4905-29	900-4905-29	Counter Knife Bolt
6.	900-9903-04	900-9902-75	Counter Knife
7.	960-0013-48	975-0001-95	Knife Clamp
8.	900-4901-68	900-4905-38	Knife holder Stud
9.	900-4901-98	900-4901-98	Flat Washer (Mill Carb)
10.	900-4901-66	900-4901-66	Nut
11.	900-9900-60	900-9900-60	Knife Babbitt (Not Shown)

NOTE: Parts may not be exactly as shown.

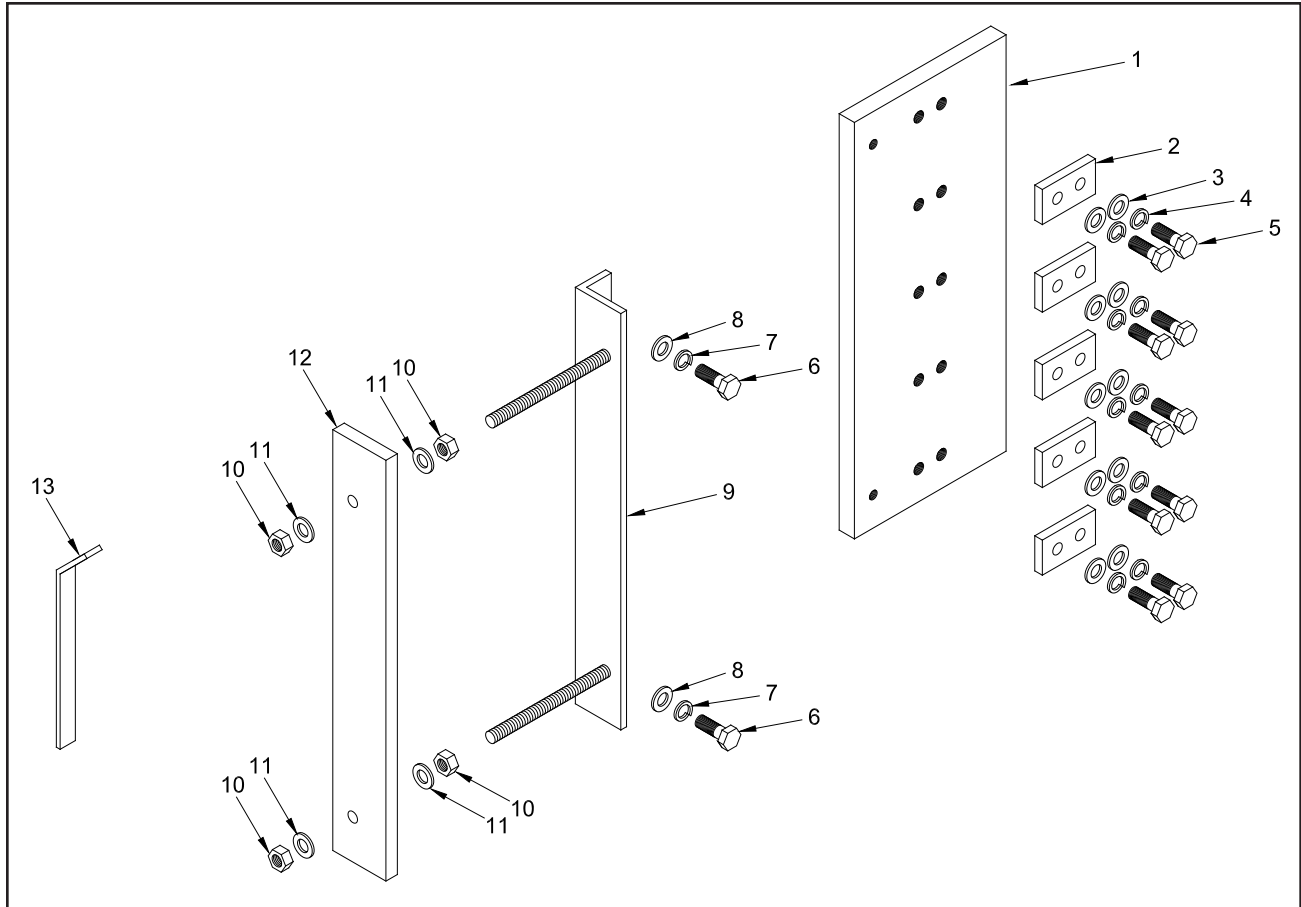

LOCATION	MODEL 1900 PART NUMBER	MODEL 2400 PART NUMBER	DESCRIPTION
1 a.	960-0020-59	975-0001-57	Anvil Only
1 b.	960-200049	975-200057	Anvil and Hardware Kit
2.	960-0007-82	960-0007-82	Double Washer
3.	900-4901-32	900-4901-32	5/8" Mill Carb Washer
4.	900-4907-04	900-4907-04	5/8" Lock Washer
5.	960-4911-11	900-4906-96	Anvil Bolt
6.	900-4906-71	900-4906-71	Adjuster Bracket Bolt
7.	900-4902-11	900-4902-11	1/2" Lock Washer
8.	900-4909-18	900-4909-18	1/2" Mill Carb Washer
9.	960-0008-34	975-0001-53	Anvil Adjuster Bracket
10.	900-4903-25	900-4903-25	5/8" Hex Nut
11.	900-4901-32	900-4901-32	5/8" Mill Carb Washer
12.	960-0002-01	975-0000-11	Anvil Puller Block
13.	981-1006-16	981-1006-16	Anvil Gauge

NOTE: Parts may not be exactly as shown.

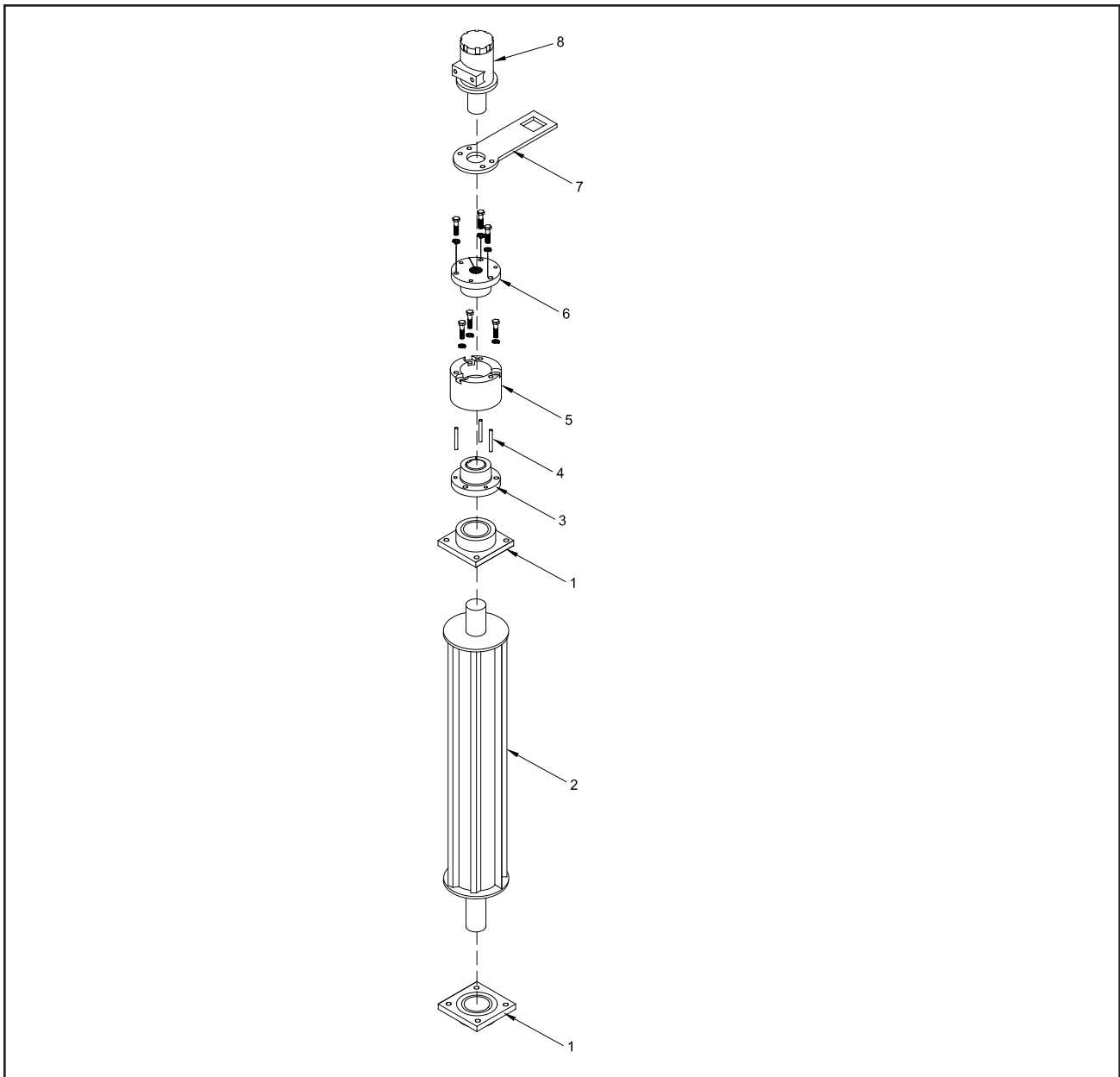

LOCATION	MODEL 1900 PART NUMBER	MODEL 2400 PART NUMBER	DESCRIPTION
1 a.	900-1912-36	900-1912-36	Feedwheel Bearing - Grip Tight Style
b.	900-1900-34	900-1900-34	Feedwheel Bearing - Set Screw Style
2 a.	960-200010	975-200015	Right Side Feedwheel (Curb Side)
b.	960-200011	975-200016	Left Side Feedwheel (Road Side)
3.	900-1903-34	900-1903-34	Keyed Bushing
4.	975-300391	975-300391	Push Out Pins
5.	975-300211	975-300211	Coupling Hub
6.	975-300252	975-300252	Splined Bushing
7.	975-300310	975-300310	Side Feedwheel Torque Arm
8.	900-3926-73	900-3926-73	Side Feedwheel Hydraulic Motor

NOTE: Parts may not be exactly as shown.

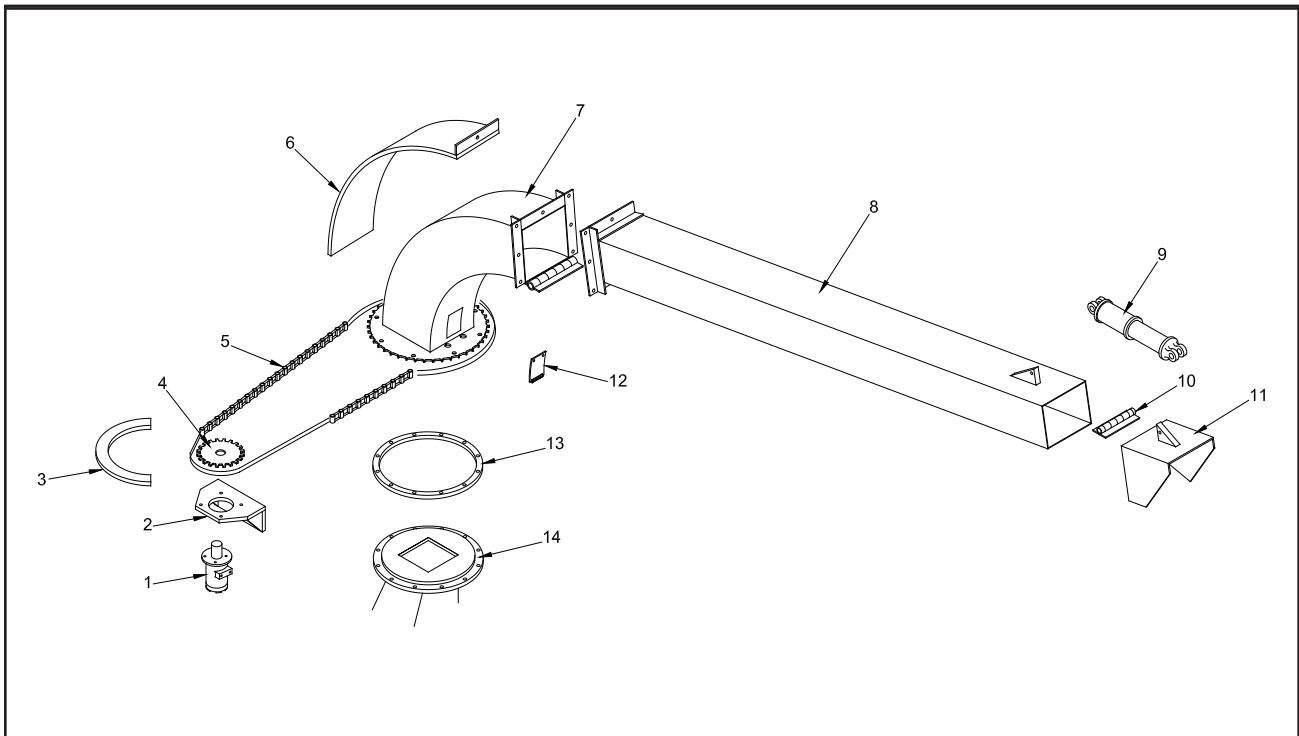

LOCATION	MODEL 1900 PART NUMBER	MODEL 2400 PART NUMBER	DESCRIPTION
1.	900-3906-30	900-3906-30	Discharge Swivel Motor
2.	975-200028	975-200028	Discharge Motor Mount
3.	960-0502-51	975-200032	Discharge Chain Guard
4.	900-1910-25	900-1910-25	Discharge Swivel Sprocket
5.	900-1901-34	900-1901-34	Discharge Swivel Chain
6.	960-200026	975-200040	Discharge Wear Liner
7.	960-200035	975-0500-14	Discharge Radius Chute
8.	960-0501-18	975-0500-38	Discharge Horizontal Chute
9.	900-3926-66	900-3926-66	Discharge Deflector Cylinder
10.	975-0006-98	975-0006-98	Discharge Deflector Hinge
11.	975-200026	975-200026	Discharge Deflector
12.	960-0013-35	960-0013-35	Discharge Clean Out Door
13.	960-0002-21	960-0002-21	Discharge Spacer Ring
14.	960-300115	960-300115	Discharge Flange Ring

NOTE: Parts may not be exactly as shown.



**MODELS 1900/2400****LOADER COMPONENTS**

LOCATION	MODEL 1900 PART NUMBER	MODEL 2400 PART NUMBER	DESCRIPTION
1.	900-3901-57	900-3901-57	Loader Swing Hydraulic Motor
2.	900-3901-59	900-3901-59	Spline Adapter
3.	900-3901-58	900-3901-58	Gear Box
4.	900-1901-44	900-1901-44	Pinion Gear
5.	960-0005-49	960-0005-49	Washer
6.	900-4906-70	900-4906-70	1/2" - 13NC Bolt
7.	900-1909-95	900-1909-95	Turntable Bearing
8.	975-200009	975-200009	Pedestal Mount Assembly
9.	975-200010	975-200010	Pedestal Assembly
10.	900-4905-44	900-4905-44	Nut
11.	900-1909-12	900-1909-12	Spherical Bushing
12.	960-0501-91	975-0500-28	Jib Boom Cylinder
13.	900-4912-55	900-4912-55	1" - 8NC Bolt
14.	900-4912-56	900-4912-56	1" Lockwasher
15.	975-300267	975-300267	Retainer Cap
16.	900-1911-53	900-1911-53	Bushing
17.	975-200022	975-200022	Jib Boom Assembly
18.	975-200054	975-200054	Jib Boom To Grapple Swing Damper Pin
19.	975-200054	975-200054	Jib Boom Cylinder To Jib Boom Pin
20.	975-200049	975-200049	Jib Boom To Main Boom Pin
21.	900-1909-53	900-1909-53	Split Bushing
22.	975-200054	975-200054	Jib Boom Cylinder To Main Boom Pin
23.	960-0501-90	975-0500-27	Main Boom Cylinder
24.	975-200054	975-200054	Main Boom Cylinder To Main Boom Pin
25.	975-200053	975-200053	Main Boom Cylinder To Pedestal Pin
26.	975-200021	975-200021	Main Boom Assembly
27.	975-200048	975-200048	Main Boom To Pedestal Pin

**NOTE: Nuts, bolts, washers, and all other components  
can be ordered by physical description.**

**Bandit**

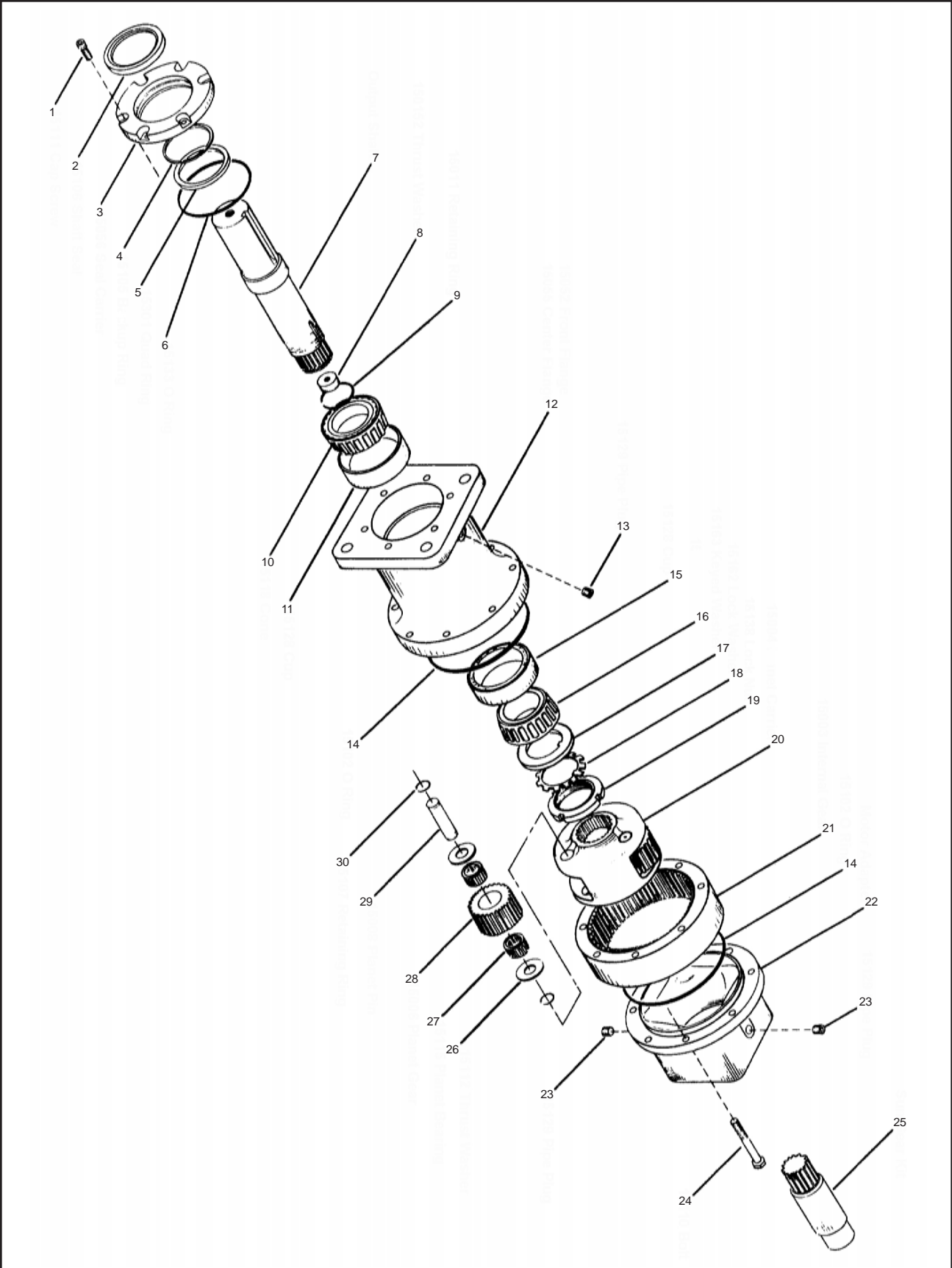

NOTE: Parts may not be exactly as shown.

**Bandit**

LOCATION	PART NUMBER	DESCRIPTION
1.	15111	Cap Screw
2.	15106	Shaft Seal*
3.	15056	Seal Carrier
4.	15105	Backup Ring*
5.	15301	Quad Ring*
6.	15133	O-Ring*
7.		Output Shaft
	15053	2.25" Straight Keyed
	15054	2.25" Tapered
	15096	16T 8/16 Spline
	15057	4-Bolt Flange
	15224	5-Bolt Flange
8.	15015-2	Thrust Washer
9.	15011	Retaining Ring
10.	15118	Cone
11.	15128	Cup
12.		Bearing Housing
	15052	Front Flange
	15055	Center Flange
13.	15121	Pipe Plug
14.	15102	O-Ring*
15.	15128	Cup
16.	15118	Cone
17.	15163	Keyed Washer
18.	15162	Lock Washer
19.	15138	Lock Nut
20.	15004	Planet Carrier
21.	15003	Internal Gear
22.		Motor Adaptor
	15205	SAE A 2-Bolt
	15064	SAE B 2-Bolt
	15241	Ross MAB & MAE
23.	15129	Pipe Plug
24.	15110	Bolt
25.		Sun Gear - Order Sun Gear Kit
26.	15112	Thrust Washer
27.	15113	Planet Bearing
28.	15005	Planet Gear
29.	15008	Planet Pin
30.	15107	Retaining Ring
31 a.	15930	Seal Kit - Buna
b.	15932	Seal Kit - Viton
32.	900-3901-58	Entire Planetary Speed Reducer Assembly

NOTE: Seal kits include items indicated by \*

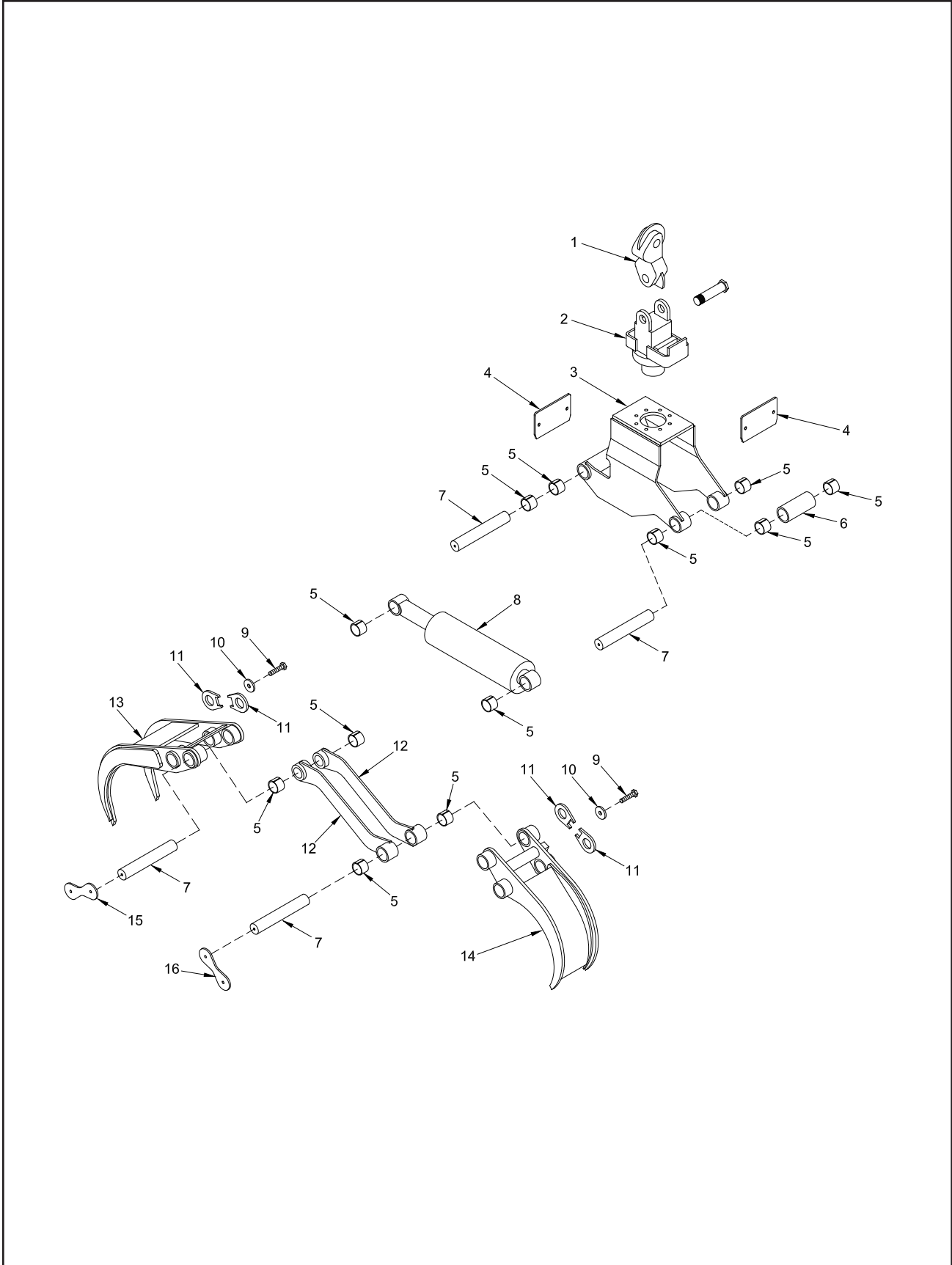

NOTE: Parts may not be exactly as shown.

**Bandit**

---

LOCATION	PART NUMBER	DESCRIPTION
1.	900-4905-68	Grapple Swing Damper
2.	900-3925-58	Grapple Rotator
3.	975-200048	Grapple Body
4.	975-300327	Enclosure Plate
5.	900-1909-53	Split Bushing
6.	975-300641	Bushing
7.	975-300082	Pin
8.	901-200001	Grapple Cylinder
9.	900-4907-12	Retainer Bolt
10.	975-300297	Pin Retainer Washer
11.	975-300296	Pin End Cap
12.	975-300079	Linkage Arm
13.	975-200050	Wide Jaw
14.	975-200049	Narrow Jaw
15.	975-300084	Pin Retainer For Wide Jaw
16.	975-300083	Pin Retainer For Narrow Jaw
17.	975-200020	Grapple Assembly (Includes 3 through 16)

**NOTE: Nuts, bolts, washers, and all other components  
can be ordered by physical description.**

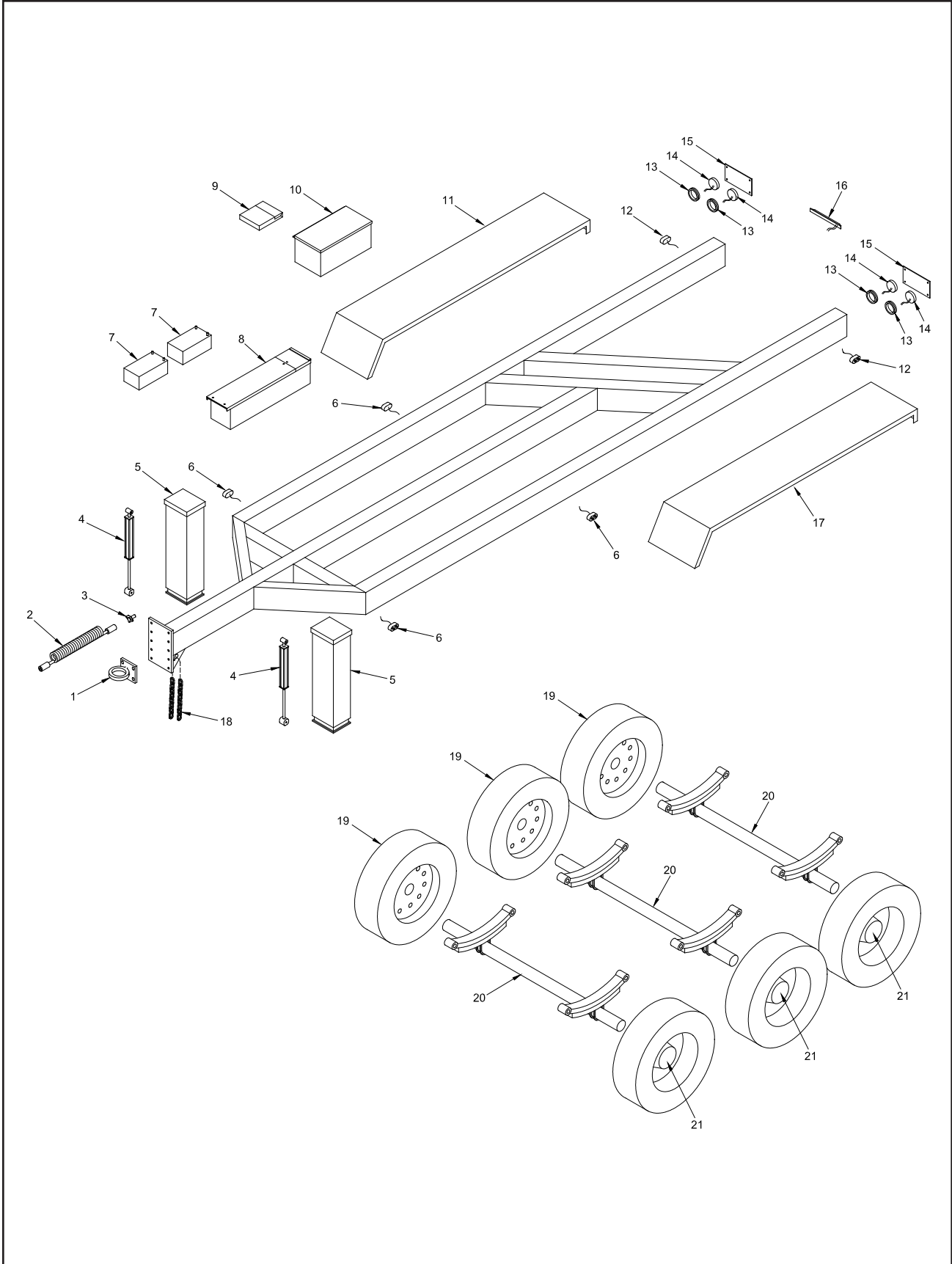

NOTE: Parts may not be exactly as shown.

**Bandit**

**MODELS 1900/2400****FRAME COMPONENTS**

LOCATION	MODEL 1900 PART NUMBER	MODEL 2400 PART NUMBER	DESCRIPTION
1.	900-5905-73	900-5905-73	3" Heavy Duty Pintle Ring Hitch
2 a.	900-2911-13	900-2911-13	Coil Cable Assembly With 7 Prong Plugs - 8'
b.	900-2911-16	900-2911-16	7-Prong Trailer Male Plug Only
3.	900-2911-15	900-2911-15	7-Prong Trailer Female Plug Only
4.	900-3923-26	900-3923-26	Front Stabilizer Cylinder
5.	975-200030	975-200030	Front Stabilizer Housing Assembly
6.	900-2907-83	900-2907-83	Amber Marker Light
7.	900-6900-73	900-6900-73	1000 CCA Battery (2 required)
8.	960-0500-51	960-0500-51	Battery box Assembly
9.	900-9902-07	900-9902-07	Manual Holder
10.	975-200039	975-200039	Tool box Assembly
11.	960-0502-90	975-0500-73	Curb Side Fender Assembly
12.	900-2900-03	900-2900-03	Red Marker Light
13.	900-2908-75	900-2908-75	Rubber Grommet For LED Tail Light
14.	900-2908-76	900-2908-76	LED Tail Light
15.	960-0501-08	960-0501-08	Clear Tail Light Cover
16.	900-2909-93	900-2909-93	LED 3 Light Bar
17.	960-0502-91	975-0500-74	Road Side Fender Assembly
18 a.	975-0005-29	975-0005-29	Safety Chain With Hooks And Spring Latches
b.	900-4904-42	900-4904-42	Hook For Safety Chain Only
19 a.	*_*	*_*	Tire And Rim Assembly
b.	*_*	*_*	Tire Only
c.	*_*	*_*	Rim Only
20 a.	900-5904-27	N/A	15,000 LBS. Air Brake Axle
b.	N/A	900-5905-26	25,000 LBS. Air Brake Axle
21.	**	**	Brake Hub And Drum Assembly

**\*\* Order Brake Hub And Drum Assembly According To Axle Type.  
(Grease Type, Oil Type, Never Lube Type).**

**\*\_\* Tires And Rims Will Vary Order By Serial Number Of Chipper Or Physical Description.**

**Bandit**

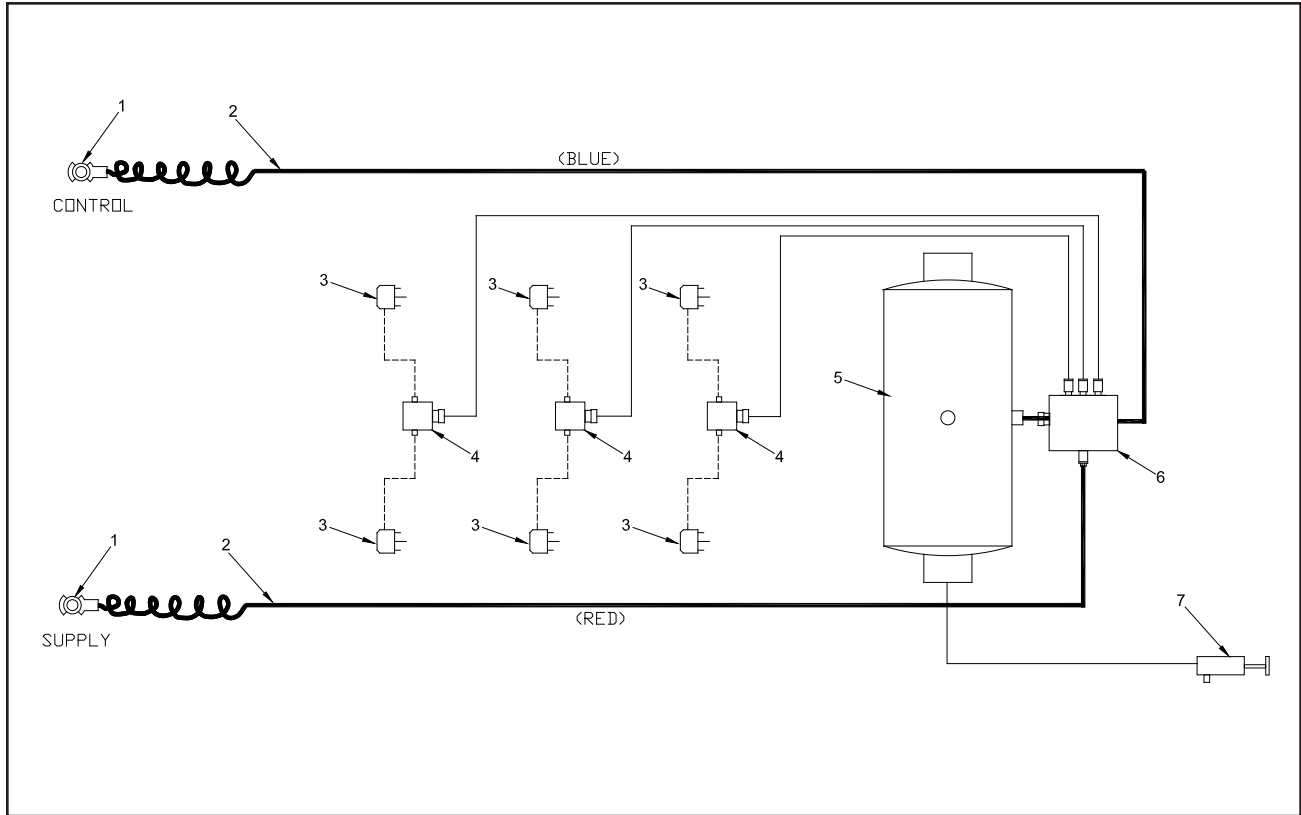

LOCATION	PART NUMBER	DESCRIPTION
1.	900-5903-81	Glad Hands
2.	900-3911-17	Coil Flex Hoses - 1 Set
3.	034-057-01	Air Chamber
4.	900-3925-61	Quick Release Valve
5.	900-5901-01	Air Tank
6.	900-5905-57	Air Tank Regulator
7.	901-100001	Brake Air Release Assembly

**NOTE: Fittings, hoses, and all other components can be ordered by physical description.**

NOTE: Parts may not be exactly as shown.

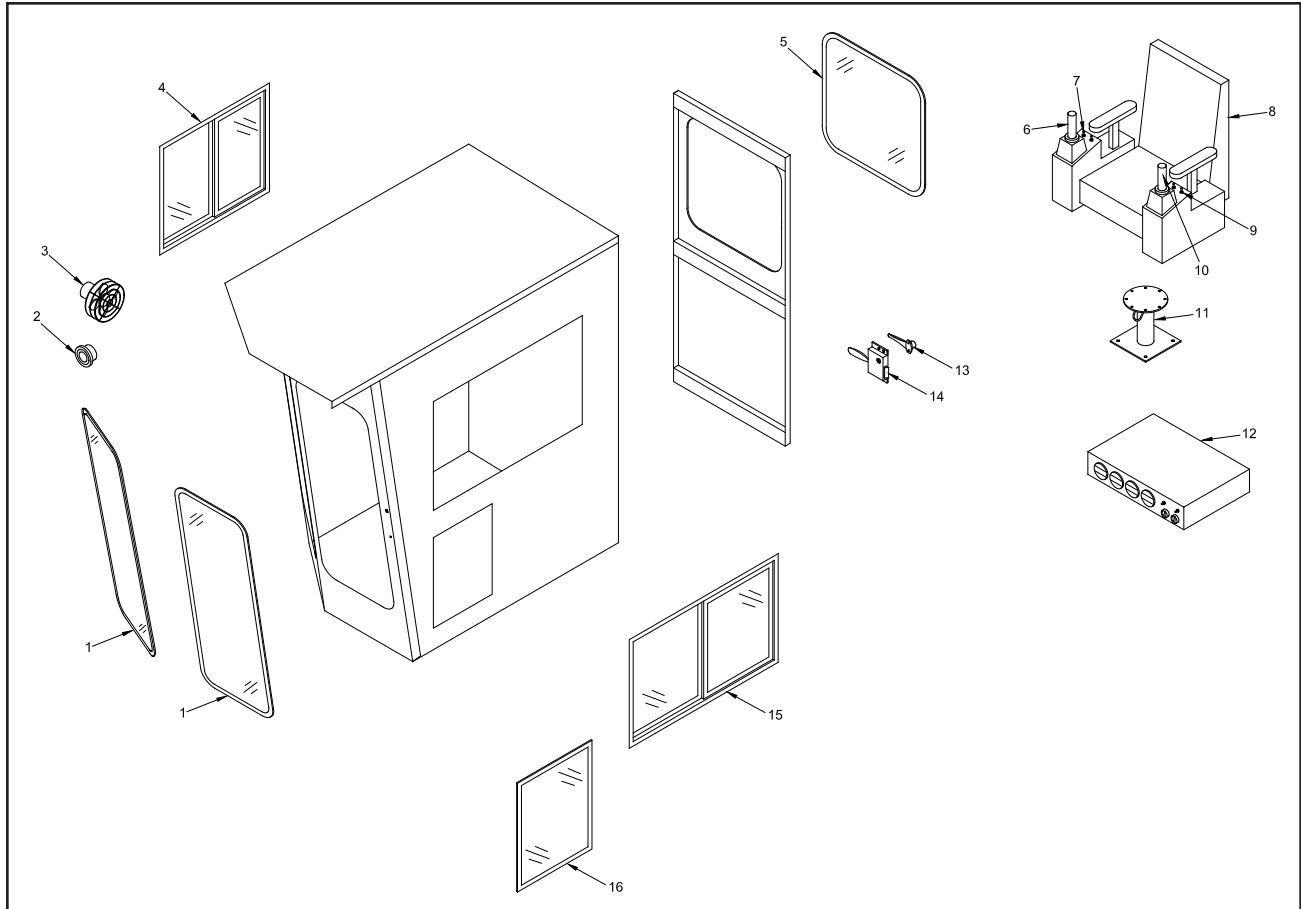

LOCATION	PART NUMBER	DESCRIPTION
1.	900-9800-03	Front Window
2.	900-2901-17	Horn
3.	900-2900-91	Cab Fan
4.	960-0004-04	Right Side Window
5.	900-9801-01	Door Window
6.	**	Right Joystick
7 a.	900-2906-97	Discharge Swivel Switch
b.	900-2906-97	Flipper Up / Down Switch
8 a.	900-9903-44	Operator's Seat
b.	900-9903-11	Seat Belt
9 a.	900-2910-46	Function Switch (Track / Loader)
b.	900-2910-46	2 Speed Switch (High / Low)
10.	**	Left Joystick
11.	900-9903-45	Seat Pedestal
12.	900-9904-31	A/C / Heater
13.	900-9900-29	Outside Door Handle
14.	900-9900-28	Inside Door Handle
15.	960-0004-03	Left Side Window
16.	900-9800-00	Kick Out Window (Track Units Only)

**\*\* Components will vary order by Serial Number of machine or physical description.**

NOTE: Parts may not be exactly as shown.

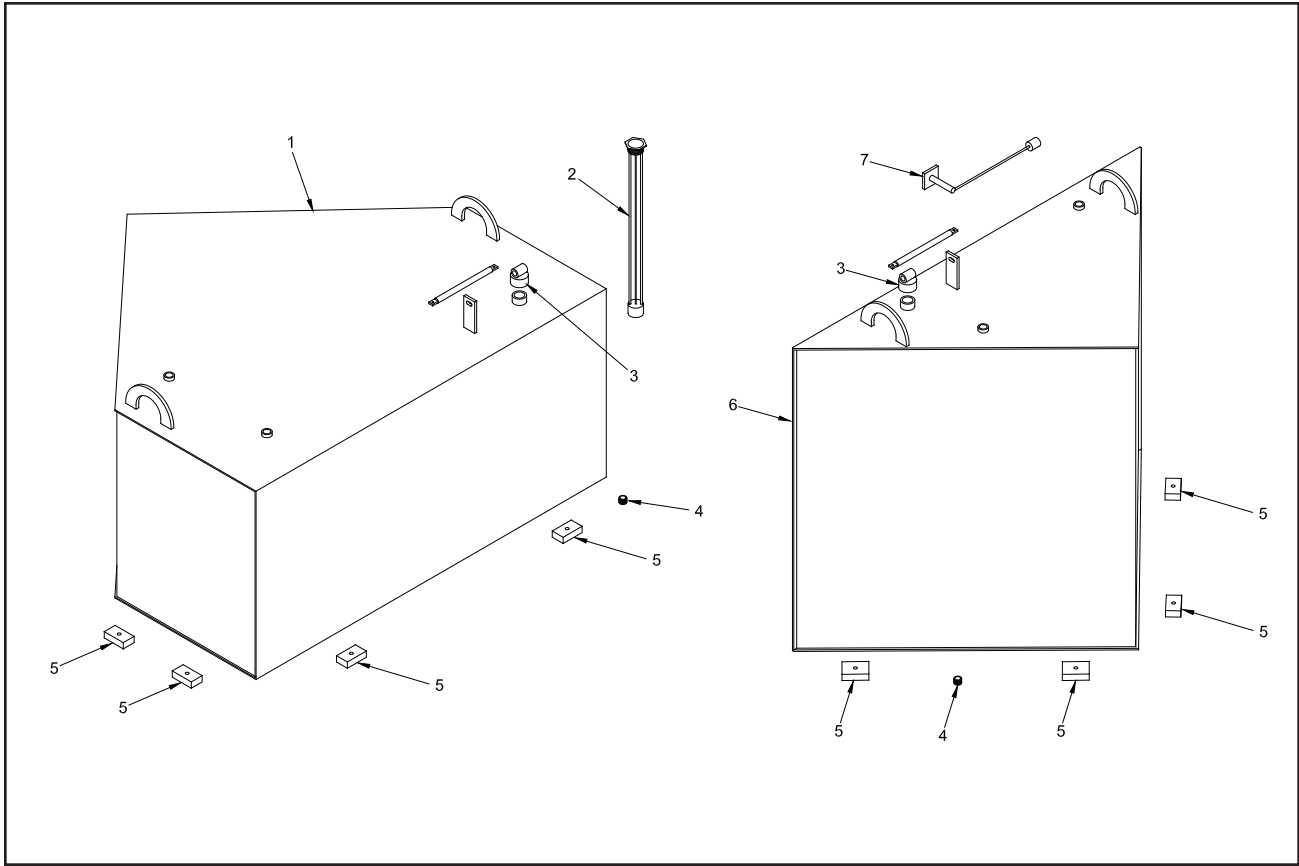

LOCATION	PART NUMBER	DESCRIPTION
1.	975-200034	340 Gallon Fuel Tank Assembly (2400 Trailerized, 2400 Track)
2.	900-2904-14	Sight Gauge (2400 Trailerized, 2400 Track)
3.	960-0502-07	Cap & Lock Assembly
4.	900-3922-60	Magnetic Drain Plug
5.	914-1000-25	Rubber Tank Mounting Pad
6.	960-200018	200 Gallon Fuel Tank Assembly (1900 Trailerized, 1900 Track)
7.	900-3905-82	Sight Gauge (1900 Trailerized, 1900 Track)
8 a.	900-4912-40	Padlock For Tank With Short Shackle For Locking Cap (Not Shown)
b.	P812	Key For Padlock (Not Shown)

NOTE: Parts may not be exactly as shown.

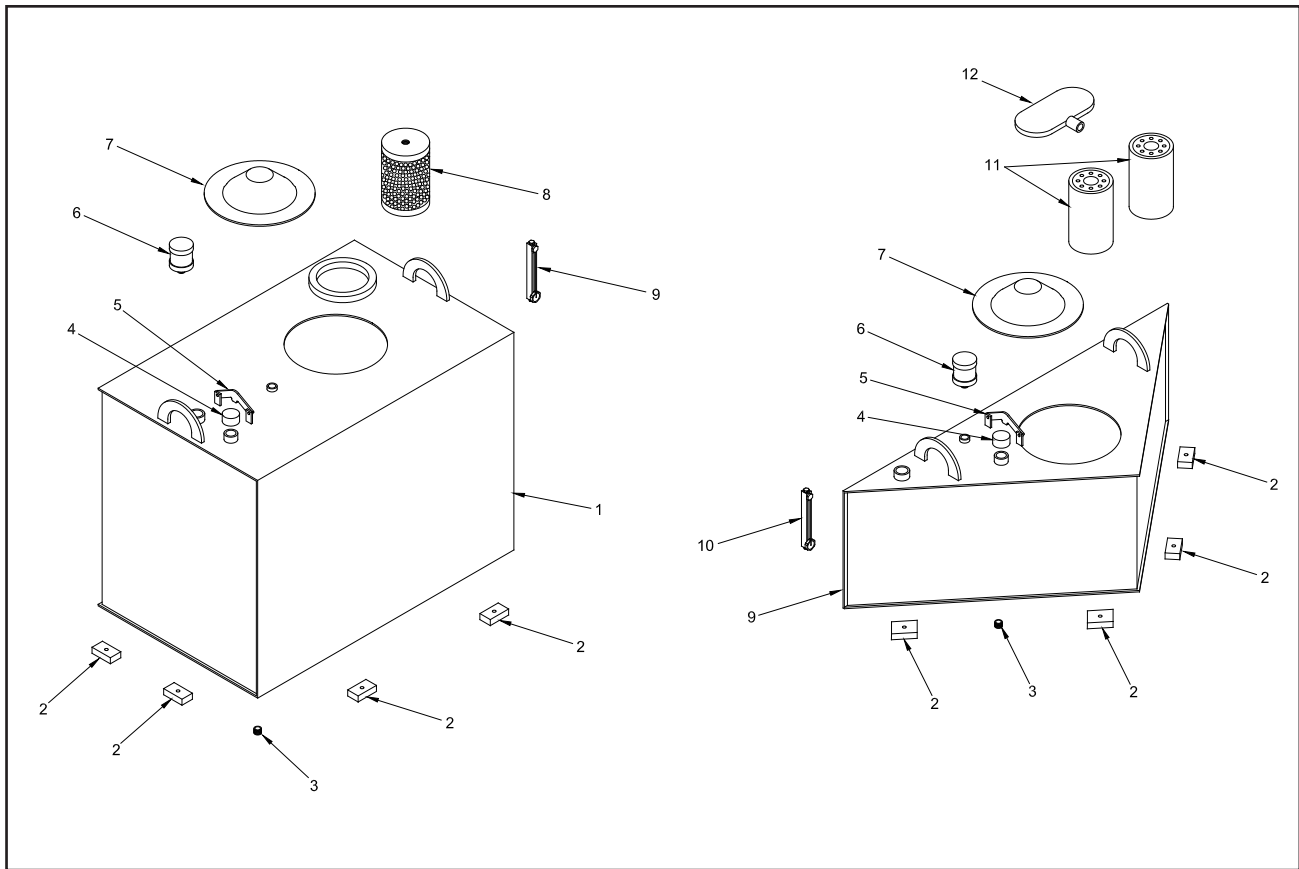

LOCATION	PART NUMBER	DESCRIPTION
1.	975-200019	200 Gallon Hydraulic Tank Assembly (1900 Track, 2400 Track, 2400 Trailerized)
2.	914-1000-25	Rubber Tank Mounting Pad
3.	900-3922-60	Magnetic Drain Plug
4.	900-3913-72	Hydraulic Tank Cap
5.	980-0506-85	Fill Cap Lock Assembly For Steel Tank
6.	900-3913-68	Moisture Separator
7.	900-3905-11	Tank Cover
8.	900-6902-89	Filter Element (Internal)
9.	960-0500-64	65 Gallon Hydraulic Tank Assembly (1900 Trailerized)
10.	900-3901-78	Temperature/Sight Gauge
11.	900-3901-66	Filter Element (External)
12.	900-3901-72	Dual Filter Head
13 a.	900-4912-40	Padlock For Tank With Short Shackle For Locking Cap (Not Shown)
b.	P812	Key For Padlock (Not Shown)

NOTE: Parts may not be exactly as shown.

FEED, DISCHARGE, LOADER, STABILIZERS, HOOD

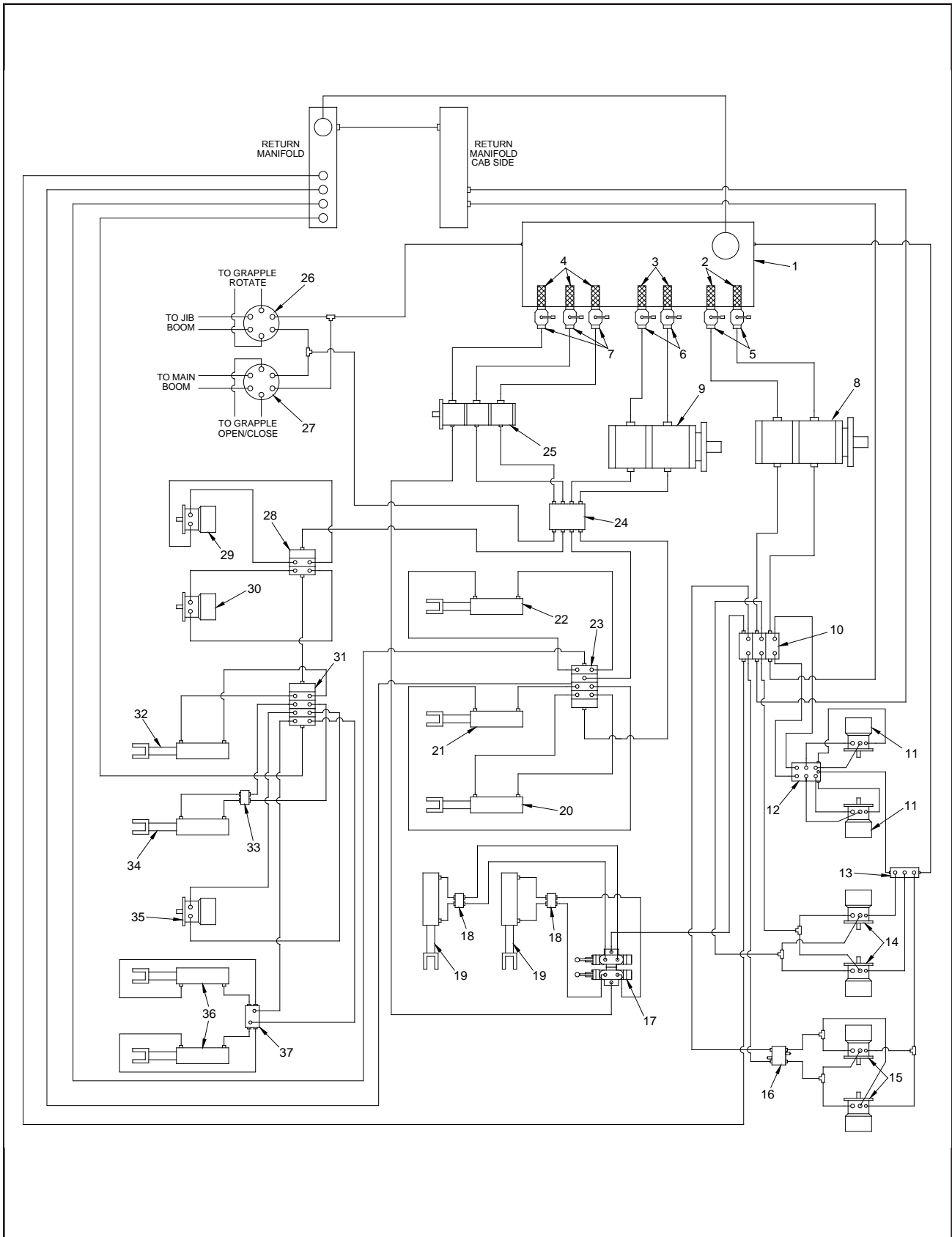

NOTE: Parts may not be exactly as shown.

**Bandit**

**MODELS 1900/2400****HYDRAULIC COMPONENTS**

LOCATION	MODEL 1900 PART NUMBER	MODEL 2400 PART NUMBER	DESCRIPTION
1.	See Page 87	See Page 87	Hydraulic Tank
2.	900-3925-22	900-3925-22	Suction Screen
3.	900-3925-21	900-3925-21	Suction Screen
4.	900-3932-05	900-3932-05	Suction Screen
5.	900-3932-06	900-3932-06	2" Shut Off Valve
6.	900-3932-07	900-3932-07	1 1/2" Shut Off Valve
7.	900-3932-08	900-3932-08	1" Shut Off Valve
8.	900-3918-93	900-3918-93	Feedwheel Pump
9.	900-3926-55	900-3926-55	Loader Pump
10 a.	900-3920-98	900-3920-98	Feedwheel Valve Bank
b.	See Pages 92-93	See Pages 92-93	Autofeed Valves
11.	900-3906-29	900-3906-29	Top Feedwheel Motor
12.	960-0020-89	960-0020-89	Junction Block
13.	975-300464	975-300464	Return Manifold
14.	900-3906-29	900-3906-29	Bottom Feedwheel Motor
15.	900-3926-73	900-3926-73	Side Feedwheel Motor
16.	900-3901-70	900-3901-70	Crossover Relief
17.	900-3902-08	900-3902-08	Stabilizer Valve
18.	900-3923-05	900-3923-05	Lock Valve
19.	900-3923-26	900-3923-26	Stabilizer Cylinder
20.	960-0501-90	975-0500-27	Main Boom Cylinder
21.	901-200001	901-200001	Grapple Cylinder
22.	960-0501-91	975-0500-28	Jib Boom Cylinder
23.	900-3932-75	900-3932-75	Valve Bank - Main Boom, Grapple Cylinder, Jib Boom
24.	900-3933-86	900-3933-86	4 Station Relief Manifold - Block Only
25.	900-3931-85	900-3931-85	Pump - Loader Swing, Side Feedwheel, Joystick Pilot
26.	**	**	Right Hand Joystick
27.	**	**	Left Hand Joystick
28.	900-3932-76	900-3932-76	Valve Bank - Loader Swing, Grapple Rotate
29.	900-3901-57	900-3901-57	Loader Swing Motor
30.	900-3925-58	900-3925-58	Grapple Rotator
31.	900-3932-78	900-3932-77	Valve Bank - Yoke, Discharge, Flipper, (Hood on 2400)
32.	N/A	900-3908-16	Chipper hood Cylinder (Model 2400 Only)
33.	900-3923-05	900-3923-05	Lock Valve
34.	900-3926-66	900-3926-66	Flipper Cylinder
35.	900-3906-30	900-3906-30	Discharge Swivel Motor
36.	900-3908-16	900-3902-36	Yoke Cylinder
37.	900-3917-50	900-3917-50	Splitter Block

**\*\* Components will vary order by Serial Number of machine or physical description.**

TRACK

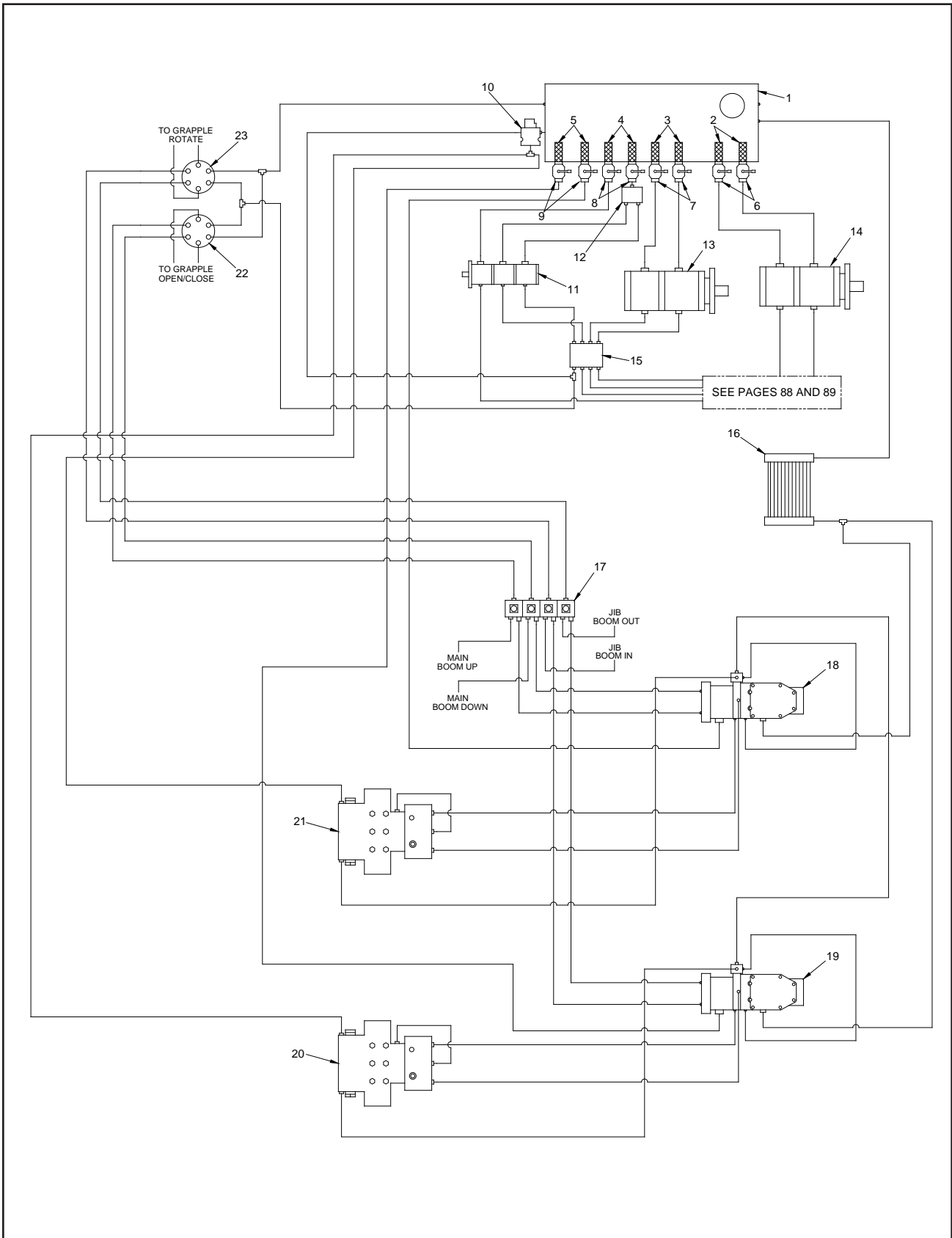

NOTE: Parts may not be exactly as shown.

**Bandit**

**MODELS 1900/2400****HYDRAULIC COMPONENTS**

LOCATION	MODEL 1900 PART NUMBER	MODEL 2400 PART NUMBER	DESCRIPTION
1.	See Page 87	See Page 87	Hydraulic Tank
2.	900-3925-22	900-3925-22	Suction Screen
3.	900-3925-21	900-3925-21	Suction Screen
4.	900-3925-05	900-3925-05	Suction Screen
5.	900-3925-05	900-3925-05	Suction Screen
6.	900-3932-06	900-3932-06	2" Shut Off Valve
7.	900-3932-07	900-3932-07	1 1/2" Shut Off Valve
8.	900-3932-08	900-3932-08	1" Shut Off Valve
9.	900-3932-08	900-3932-08	1" Shut Off Valve
10.	900-3928-91	900-3928-91	High/Low Speed Switch
11.	900-3931-85	900-3931-85	Pump - Loader Swing, Side Feedwheel, Joystick Pilot
12.	960-300266	960-300266	Suction Manifold
13.	900-3926-55	900-3926-55	Loader Pump
14.	900-3918-93	900-3918-93	Feedwheel Pump
15.	900-3933-86	900-3933-86	4 Station Relief Manifold - Block Only
16.	900-3928-67	900-3928-67	Hydraulic Oil Cooler
17.	900-3904-62	900-3904-62	Solenoid Valve - Loader / Track
18 a.	900-3931-46	900-3931-46	Cab Side Track Pump
b.	900-3904-38	900-3904-38	Track Pump Filter (Not Shown)
19 a.	900-3931-45	900-3931-45	Fuel Tank Side Track Pump
b.	900-3904-38	900-3904-38	Track Pump Filter (Not Shown)
20.	**	**	Fuel Tank Side Track Motor
21.	**	**	Cab Side Track Motor
22.	**	**	Left Hand Joystick
23.	**	**	Right Hand Joystick

**\*\* Components will vary order by Serial Number of machine or physical description.**

# AUTOFEED VALVES

## TOP & BOTTOM FEEDWHEELS

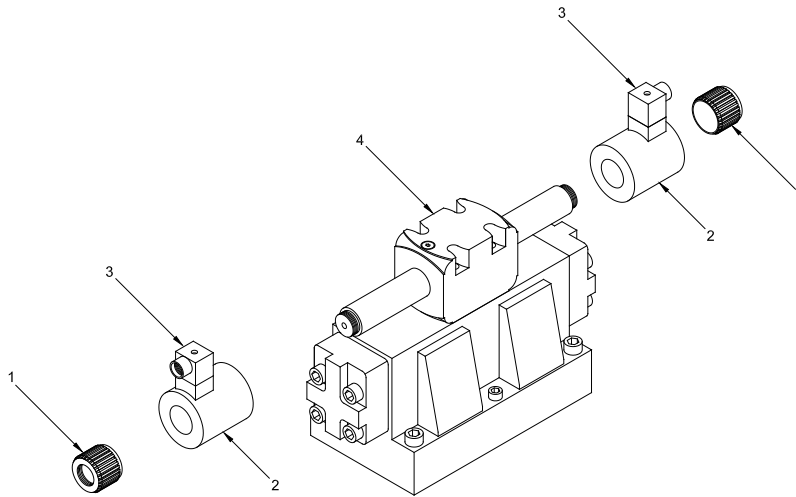

## SIDE FEEDWHEELS

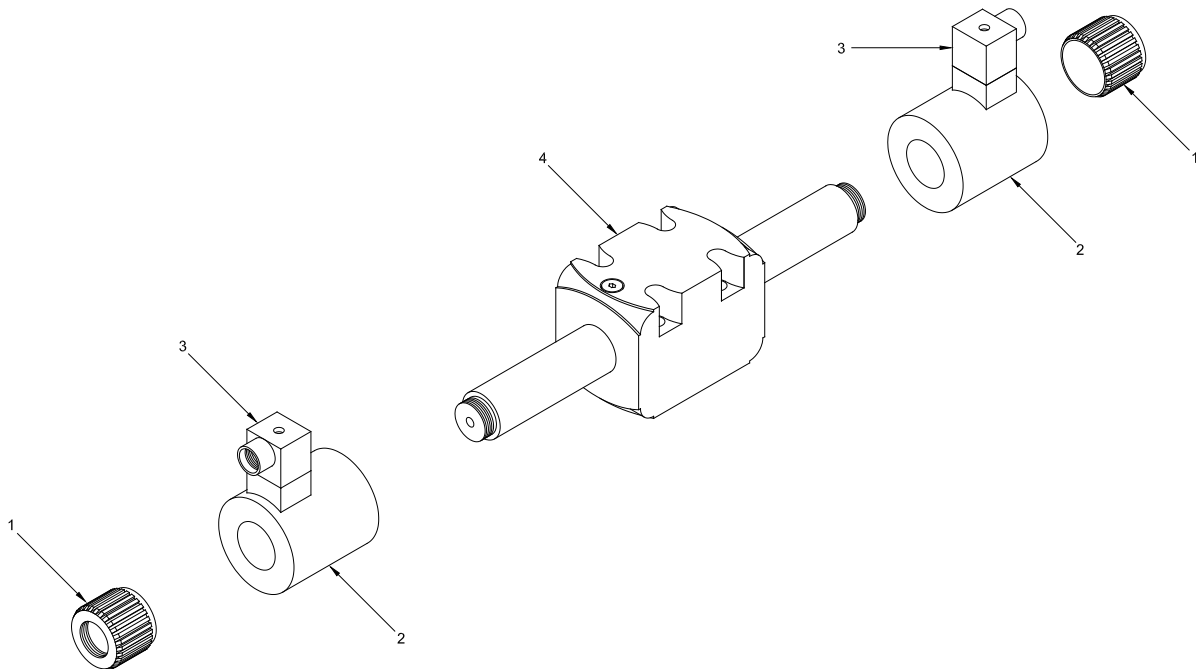

NOTE: Parts may not be exactly as shown.

**Bandit**

**TOP & BOTTOM FEEDWHEELS**

LOCATION	PART NUMBER	DESCRIPTION
1.	900-3933-93	Solenoid Retainer Nut
2.	900-3927-05	Solenoid Only
3.	900-3918-63	Molded Wire Plug Assembly
4.	N/A	Valve Body Only
5.	900-3933-92	D07 Valve Assembly (Includes #'s 1,2, & 3)
6.	900-3920-71	16' Cord and Molded Herschman Connector (Not Shown)

**SIDE FEEDWHEELS**

LOCATION	PART NUMBER	DESCRIPTION
1.	900-3933-91	Solenoid Retainer Nut
2.	900-3933-90	Solenoid Only
3.	900-3918-63	Molded Wire Plug Assembly
4.	N/A	Valve Body Only
5.	900-3933-89	D05 Valve Assembly (Includes #'s 1,2, & 3)
6.	900-3920-71	16' Cord and Molded Herschman Connector (Not Shown)

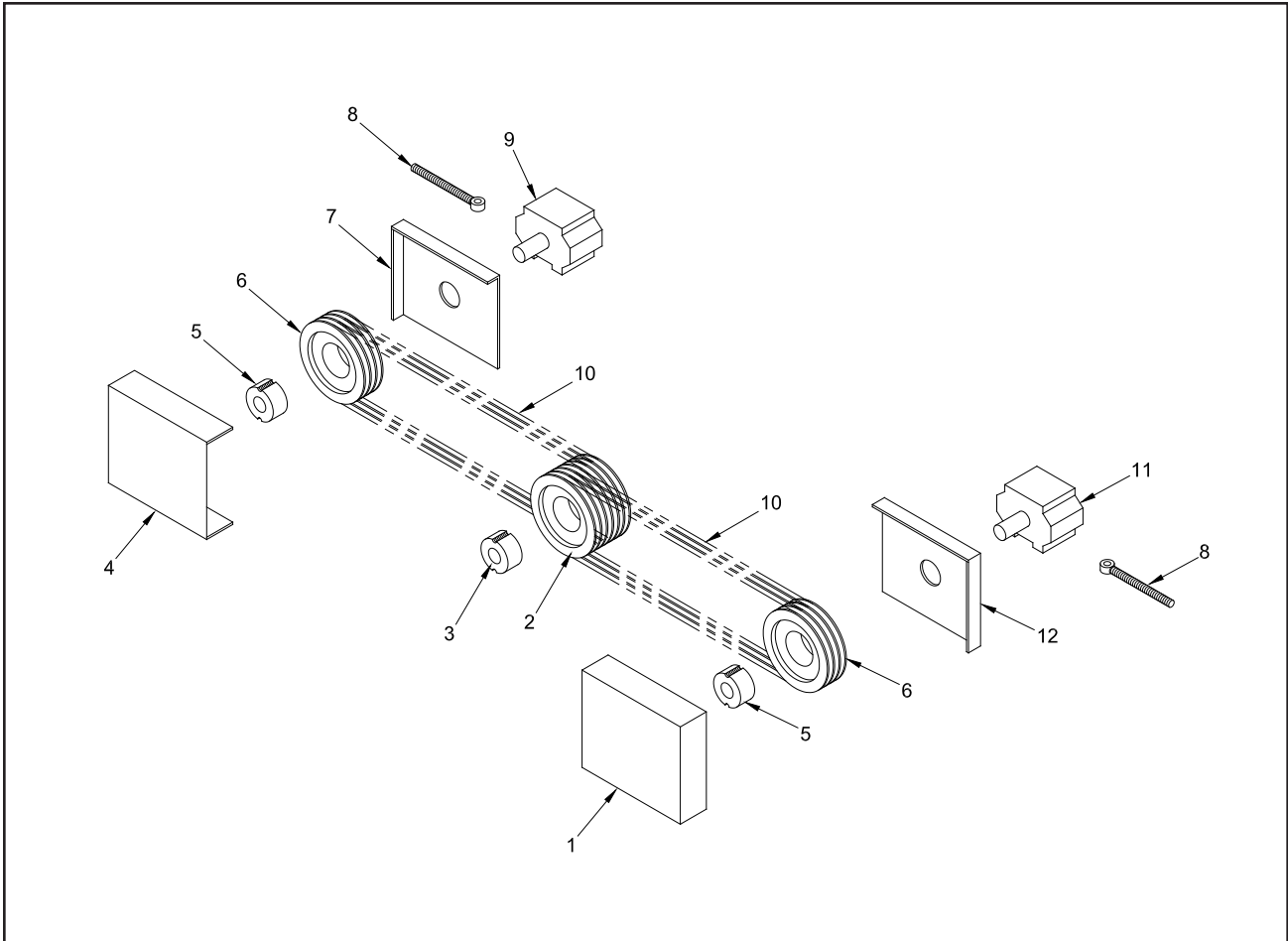

LOCATION	MODEL 1900 PART NUMBER	MODEL 2400 PART NUMBER	DESCRIPTION
1.	960-300184	975-0001-59R	Sheave Guard Cover
2.	**	**	Pump Drive Sheave
3.	**	**	Pump Driver Bushing
4.	960-300183	975-0001-59L	Sheave Guard Cover
5.	**	**	Loader Pump Bushing
6.	**	**	Loader Pump Sheave
7 a.	960-0017-76L	975-0001-60L	Sheave Guard Mount (Trailerized Unit Only)
b.	960-300277L	960-300277L	Sheave Guard Mount (Track Unit Only)
8.	900-4905-11	900-4905-11	Pump Belt Tension Adjuster Bolt
9 a.	900-3901-64	900-3901-64	Loader Pump Bearing Block (Trailerized Unit Only)
b.	900-3904-59	900-3904-59	Pump Bearing Block (Track Unit Only)
10.	**	**	Pump Belt
11 a.	900-3913-31	900-3913-31	Feedwheel Pump Bearing Block (Trailerized Unit Only)
b.	900-3904-59	900-3904-59	Pump Bearing Block (Track Unit Only)
12 a.	960-0017-76	975-0001-60R	Sheave Guard Mount (Trailerized Unit Only)
b.	960-300277R	960-300277R	Sheave Guard Mount (Track Unit Only)

**\*\* Components will vary order by Serial Number of machine or physical description.**

**NOTE: Nuts, bolts, washers, and all other components can be ordered by physical description.**

NOTE: Parts may not be exactly as shown.

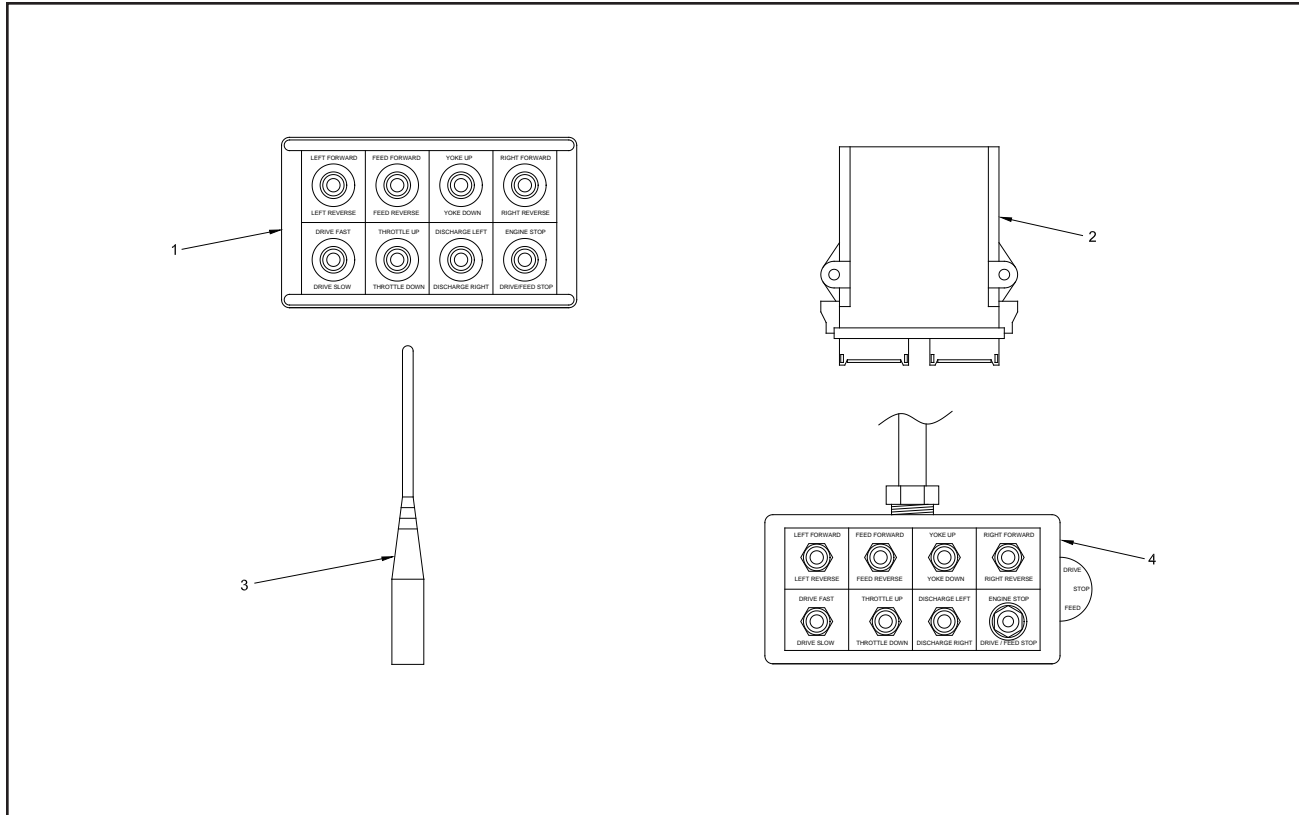

LOCATION	PART NUMBER	DESCRIPTION
1 a.	900-2912-81	Radio Transmitter - Trailerized Unit
b.	900-2912-63	Radio Transmitter - Tracks Only
c.	900-2912-64	Radio Transmitter - Tracks, Feed, Yoke, Throttle, Discharge
d.	900-2912-65	Radio Transmitter - Tracks, Feed, Yoke, Throttle, Discharge, Flipper
2 a.	900-2912-80	Radio Receiver - Trailerized Unit
b.	900-2912-62	Radio Receiver - Track Unit
3.	900-2912-66	Antenna
4 a.	900-2912-82	Tether Transmitter - Trailerized Unit
b.	900-2912-67	Tether Transmitter - Tracks Only
c.	900-2912-35	Tether Transmitter - Tracks, Feed, Yoke, Throttle, Discharge
d.	900-2912-69	Tether Transmitter - Tracks, Feed, Yoke, Throttle, Discharge, Flipper
5.	900-2912-36	Harness - Track Units (Not Shown)
6 a.	900-2912-79	Radio Remote Kit - Trailerized Unit (Includes 1a,2a,3)
b.	900-2912-68	Radio Remote Kit - Tracks Only (Includes 1b,2b,3)
c.	900-2912-34	Radio Remote Kit - Tracks, Feed, Yoke, Throttle, Discharge (Includes 1c,2c,3)
d.	900-2912-70	Radio Remote Kit - Tracks, Feed, Yoke, Throttle, Discharge, Flipper (Includes 1d,2d,3)

NOTE: Parts may not be exactly as shown.

