



OPERATIONS, SERVICE AND PARTS MANUAL



LEEBOY MODEL 8500B CONVEYOR PAVER

Manual No. 1003097

Introduction

1

Safety

2

General Information

3

Specifications

4

Component Location

5

Operation

6

Maintenance

7

Troubleshooting

8

Schematics

9

Illustrated Parts List (IPL)

10

DISCLAIMER AND COPYRIGHT

Disclaimer:

All information, illustrations and specifications in this manual are based on the latest information available at the time of publishing. The illustrations used in this manual are intended as representative reference views only. Moreover, because of our continuous product improvement policy, we may modify information, illustrations and/or specifications to explain and/or exemplify a product, service or maintenance improvement. We reserve the right to make any change at any time without notice. VT LeeBoy, Inc., VT LeeBoy, and LeeBoy are all the same entity and are used interchangeably.

©2010 VT LeeBoy, Inc.

LeeBoy reserves all copyright and other rights in this manual and the manual's content. No part of this manual may be reproduced or used in any way without the written permission of LeeBoy, except as necessary to operate LeeBoy equipment.

This manual has been most recently updated 04/10 to apply to units with serial number 58239 and above:

Refer to manual no. 986947 for units with serial number 44987 to 58238.



TABLE OF CONTENTS

	Page
Table Of Contentsv
Introduction	1-1
Safety	2-1
Safety Precautions	2-3
Safety Label Locations	2-6
Safety Precautions.	2-6
General Information	3-1
Limited Warranty Policy	3-2
Warranty.	3-2
Limitations.	3-2
Items Not Covered	3-3
Other Limitations.	3-3
Contact Information	3-4
Record of Ownership	3-4
Nameplate	3-4
Specifications	4-1
General Information	4-2
Engine.	4-2
Hydraulic System	4-2
Torque Hubs.	4-2
Hopper	4-2
Operator Platform	4-2
Screed	4-3
Electrical System	4-3
Specification charts	4-4
Dimensions	4-6

Torque Specs: Inch	4-7
Torque Specs: Metric	4-8
Component Location	5-1
Location of Operation Panels and Controls	5-2
Main Dash Panel	5-4
Main Dash Panel (Continued).	5-6
Speed and Steering Control Levers	5-8
Hydraulic Controls	5-10
Paving Controls	5-12
Electric screed Operation Controls.	5-14
Operation	6-1
General Information	6-3
Pre-Start Inspection and Preparation.	6-4
Starting The Engine	6-4
Preliminary.	6-4
Engine Start-Up	6-4
Stopping the Engine	6-5
Paver Driving Instructions	6-5
General Control Information	6-5
Operating Information	6-5
Paver Operation	6-6
Conveyor Operation	6-6
Hydraulic Cutoff Gates Operation	6-7
Spray Down	6-7
Sonic Augers Operation	6-7
Auger Extensions	6-8
Electric Flight Screws Operation (Option)	6-9
Burner Ignition Procedure	6-9
Electric Heating Controls (Option)	6-11
Starting To Pave	6-12
Setting Screed To Pave	6-13
Setting Screed End Gates	6-14
Setting Screed Extensions.	6-15
Mat Texture Adjustment	6-15
Unloading And Loading.	6-16
Unloading	6-16

Loading	6-17
Tie Down Procedure	6-17
Electric Screed Heating System (Option)	6-18
Generator	6-18
Control Box	6-19
Cycle Timer	6-20
Element Relay	6-20
Element Breaker	6-21
Element Connections	6-21
Element Assembly	6-21
Truck Hitch Attachment (Option)	6-22
Umbrella (Option)	6-23
Maintenance	7-1
Lubrication Chart	7-4
Maintenance Schedule	7-6
General Information	7-6
Preparing Paver for Maintenance	7-6
Paver Lubrication	7-6
10-Hour or Daily Routine Maintenance	7-7
50-Hour (Initial) or Weekly Routine Maintenance	7-7
100-Hour or Monthly Routine Maintenance	7-8
250-Hour or Quarterly Routine Maintenance	7-8
500-Hour or Semi-Annual Routine Maintenance	7-8
1000-Hour or Annual Routine Maintenance	7-8
Maintenance Adjustments	7-9
Extension Top Guide Adjustment	7-9
Replacing Screed Extension Wear Plates	7-9
Replacing Screed Main Wear Plates	7-10
Raising Conveyor	7-11
Lowering Conveyor	7-11
Conveyor Flight Chain Adjustment	7-12
Automatic Track Adjustment	7-12
Conveyor Drive Chain Adjustment	7-13
Torque Hub Hydraulic Motor Adjustment	7-13
Auger Drive Chain Adjustment	7-14
Torque Hub Lubrication	7-14

Track Tension Pressure Relief	7-14
Track Tension Release	7-14
Conveyor Limit Switch Adjustment	7-15
Electrical System.	7-16
Generator Voltage Testing	7-16
Generator Speed Tuning.	7-17
Generator Capacitor Replacement.	7-19
Testing Element Relays	7-19
Testing Element Resistance	7-20
Battery Servicing.	7-20
Engine Maintenance	7-21
General Information	7-21
Engine Lubrication Oil - Kubota	7-21
Changing Engine Lubrication Oil Filter	7-22
Engine Lubrication Oil - CAT	7-23
Changing Engine Lubrication Oil Filter	7-24
Fuel system	7-24
Fuel Tank	7-24
Engine Fuel Filters.	7-25
Engine Air Filter	7-25
Hydraulic System	7-26
General Information	7-26
Checking Hydraulic Oil Level	7-26
Adding Hydraulic Oil To Hydraulic Oil Reservoir	7-26
Changing Hydraulic Oil.	7-27
Changing Hydraulic Oil Strainer	7-28
Removal & Installation Procedures	7-28
Track Component Replacement	7-28
Rubber Track Replacement	7-30
Torque Hub Replacement	7-31
Rear Conveyor Shaft Replacement.	7-32
Auger And Inner Bearing Replacement.	7-33
Screed Extensions, Slides Or Bushing Replacement	7-34
Screed Wear Plate Replacement.	7-34
Extension Wear Plate Replacement	7-35
Tandem Servo Pump Replacement	7-35

2-Speed Hydraulic Motor Replacement	7-36
Safety Label Installation	7-37
Troubleshooting	8-1
Troubleshooting Charts	8-2
Schematics	9-1
Electrical 1 of 4	9-3
Electrical 2 of 4	9-5
Electrical 3 of 4	9-7
Electrical 4 of 4	9-9
Hydraulic 1 of 5	9-11
Hydraulic 2 of 5	9-13
Hydraulic 3 of 5	9-15
Hydraulic 4 of 5	9-17
Hydraulic 5 of 5	9-19
Illustrated Parts List (IPL)	10-1
Quick Reference Guide - Filters	10-3
Sprocket Drive Track System (4 Roller Undercarriage)	10-4
Sprocket Drive Track System (4 Roller Undercarriage) (continued).	10-6
Rubber Track Undercarriage (5 Roller Undercarriage)	10-8
Conveyor Drive Assembly	10-10
Conveyor Drive Assembly (continued)	10-12
Hopper Components	10-14
Hopper Components (components)	10-16
Auger Assembly	10-18
Conveyor Drive Cutoff, Screed Lift Cylinders	10-20
Hydraulic Components LH Side Fuel Tank	10-22
Kubota Engine	10-24
Kubota Engine (continued).	10-26
Kubota Engine (continued).	10-28
Cat Engine.	10-30
Cat Engine (continued).	10-32
Cat Engine (continued).	10-34
Pump Components	10-36
Main Valve And Spray Down (Option).	10-38
Screed Arm Assembly With Manual or Electric Toe Point	10-40
Propane Heater And Automatic Ignitors	10-42

Auger Extension10-44
Paver Leveling Control (TOPCON) System 410-46
Paver Leveling Control (TOPCON) System 510-48
Truck Hitch Assembly10-50
Controls - Right Side High Deck10-52
Controls - Right Side Low Deck10-54
Controls - Left Side10-56
Controls - Left Side (continued)10-58
Main Valve Manifold Detail	10-60
Kubota Sheet Metal Cover - High Deck.10-62
Kubota Sheet Metal Cover - High Deck (continued).10-64
Kubota Sheet Metal Cover - Low Deck	10-66
Kubota Sheet Metal Cover - Low Deck (continued)	10-68
CAT Sheet Metal Cover - High Deck10-70
CAT Sheet Metal Cover - High Deck (continued)10-72
CAT Sheet Metal Cover - Low Deck10-74
CAT Sheet Metal Cover - Low Deck (continued)10-76
Strike Offs And Extensions.10-78
Instrument Panel Dash - Controls and Gauges	10-80
Instrument Panel Dash - Relays and Fuses.10-82
Screed Non-sloping Overview10-84
Screed Frame Non-Sloping - Propane	10-86
Extension Single Adjust LH Assembly - Propane	10-88
Extension Single Adjust RH Assembly - Propane	10-90
Extension Double Adjust LH Assembly - Propane.10-92
Extension Double Adjust RH Assembly - Propane10-94
Screed Frame Non-Sloping - Electric	10-96
Vibrator Assembly	10-98
Walk Board Assembly	10-100
Slide Plate Assembly.	10-102
Extension Single Adjust LH Assembly - Electric.	10-104
Extension Single Adjust RH Assembly - Electric	10-106
Extension Double Adjust LH Assembly - Electric	10-108
Extension Double Adjust RH Assembly - Electric	10-110
Endgate LH Assembly	10-112
Endgate RH Assembly	10-114

- Screed Pull Arms LH Assembly 10-116
- Screed Pull Arms RH Assembly 10-118
- Citrus Tank & Heat Control Box 10-120
- Screed Miscellaneous Components 10-122
- Generator 10-124
- Alphabetical Parts Index 10-126

NOTES



Section 1

INTRODUCTION

Thank you for purchasing the LeeBoy Model 8500B Conveyor Paver. We wish you many years of safe and efficient operation of your paver.

READ THIS MANUAL PRIOR TO OPERATING the paver. This manual is an important part of the paver and should be kept with the paver at all times in the dedicated storage container on the paver. Even though you may be familiar with similar equipment, you **MUST** read and understand this manual before operating this paver. Reading the manual will help you and others avoid injury and help prevent any damage to the paver. If this manual becomes lost or damaged, contact your authorized LeeBoy Dealer immediately to order a replacement, (see **Contact Information** in Section 3).

This manual is intended as a guide for the safe and efficient use of the paver. This manual covers the procedures for proper operation and maintenance of the paver. This manual contains information that was available at the time of printing and are subject to change without notice.

This manual should be used with all related supplemental books, engine and transmission manuals, and parts books. Related Service Bulletins should be reviewed to provide information regarding some of the recent changes.

If any questions arise concerning this publication or others, contact your local LeeBoy Dealer for the latest available information.

This manual provides information for use by the equipment operator under the following headings:

Safety—See Section 2 for important safety guidelines information.

General Information—See Section 3 for important warranty, contact, and nameplate information.

Specifications—See Section 4 for all major system specifications and typical torque value tables.

Component Location—See Section 5 for general overview of controls and major components.

Operation—See Section 6 for control functionality and normal equipment operation.

Maintenance—See Section 7 for basic preventive maintenance and repair procedures.

Troubleshooting—See Section 8 for problem descriptions and recommended solution tables.

Schematics—See Section 9 for schematic diagrams of electrical wiring.

Illustrated Parts List (IPL)—See Section 10 for illustrations, descriptions and part numbers of available service parts.

NOTES



Section 2 SAFETY

	Page
Safety	2-1
Safety Precautions	2-3
Safety Label Locations	2-6
Safety Precautions	2-6

This manual provides important information to familiarize you with safe operating and maintenance procedures. Even though you may be familiar with similar equipment, you **MUST** read and understand this manual before operating the LeeBoy Model 8500B Conveyor Paver and follow its instructions when operating the paver.

Safety is everyone's business and is our top concern. Knowing the guidelines covered in this section and in Section 1 will help ensure your safety, the safety of those around you and the paver's proper operation.

LOOK FOR THESE SYMBOLS WHICH POINT OUT ITEMS OF EXTREME IMPORTANCE TO THE SAFETY OF YOU AND YOUR COWORKERS. READ AND UNDERSTAND THOROUGHLY. HEED THE WARNING AND FOLLOW THE INSTRUCTIONS.

Keep safety labels in good condition. If safety labels become missing or damaged, replacement safety labels are available from your LeeBoy Dealer (see **Contact Information** in Section 3 and **Safety Label Installation** in Section 7).

DANGER

Indicates a hazardous situation which, if not avoided, **will result in death or serious injury.**

WARNING

Indicates a hazardous situation which, if not avoided, **could result in death or serious injury.**

CAUTION

Indicates a hazardous situation which, if not avoided, **could result in minor or moderate injury.**

NOTICE

Indicates a situation which can cause damage to the equipment, personal property and/or the environment, or cause the LeeBoy Model 8500B Conveyor Paver to operate improperly.

NOTE: Indicates a procedure, practice, or condition that should be followed in order for the paver or component to function in the manner intended.

SAFETY PRECAUTIONS

CAUTION

The safety messages that follow have CAUTION level hazards.

Pre-Operation Hazard



Read and understand this Operation Manual before operating or servicing the engine to ensure that safe operating practices and maintenance procedures are followed.

- Never permit anyone to service or operate the LeeBoy Model 8500B Conveyor Paver without proper training.
- Safety signs and labels are additional reminders for safe operating and maintenance techniques.
- Contact LeeBoy or an authorized LeeBoy Dealer for additional training.
- Make sure you are aware of all laws and regulations that are in effect where the paver is operated. Make sure you have all necessary licenses to operate the paver.

WARNING

The safety messages that follow have WARNING level hazards.

Crush Hazard

Keep bystanders away from work area before and during operation.

Modification Hazard

Never modify the LeeBoy Model 8500B Conveyor Paver without written consent of LeeBoy. Any modification can affect the safe operation of the paver and may cause personal injury or death.

Exposure Hazard



Always wear personal protective equipment, including appropriate clothing, gloves, work shoes, and eye and hearing protection, as required by the task at hand.

Explosion Hazard



While the engine is running or the battery is charging, hydrogen gas is being produced and can be easily ignited. Keep the area around the battery well-ventilated and keep sparks, open flame and any other form of ignition out of the area.

- Always disconnect the negative (-) battery cable before servicing the paver.
- Do not start the engine by shorting the starter circuit or any other starting method not stated in this manual. Only use the starting procedure as described in this manual to start the engine.
- Never charge a frozen battery. Always slowly warm the battery to room temperature before charging.

Fire and Explosion Hazard

- Diesel fuel is flammable and explosive under certain conditions.
- Never use a shop rag to catch the fuel.
- Wipe up all spills immediately.
- Never refuel with the engine running.
- Store any containers containing fuel in a well-ventilated area, away from any combustibles or sources of ignition.

Fire Hazard



Have appropriate safety equipment available. Have all fire extinguishers checked periodically for proper operation and/or readiness.

- Always read and follow safety-related precautions found on containers of hazardous substances like parts cleaners, primers, sealants and sealant removers.
- Undersized wiring systems can cause an electrical fire.

WARNING

The safety messages that follow have **WARNING** level hazards.

Exhaust Hazard



All internal combustion engines create carbon monoxide gas during operation and special precautions are required to avoid carbon monoxide poisoning:

- Never block windows, vents or other means of ventilation if the LeeBoy Model 8500B Conveyor Paver is operating in an enclosed area.
- Always ensure that all connections are tightened to specifications after repair is made to the exhaust system.

Entanglement/Sever Hazard



Verify there are no people, obstacles or other equipment near the LeeBoy Model 8500B Conveyor Paver before starting the engine. Sound the horn as a warning before starting the engine.



If the engine must be serviced while it is operating, remove all jewelry, tie back long hair and keep hands, other body parts and clothing away from moving/rotating parts.

- Always stop the engine before beginning service.
- Verify that all paver guards and covers are attached properly to the paver before starting the engine. Do not start the engine if any guards or covers are not properly installed on the paver.
- If you must run the engine during maintenance procedures, make sure you have a helper to keep bystanders clear of the paver and make observations of moving parts as requested by the operator.
- Always turn the start switch to the OFF position after operation is complete and remove the key from the switch. Keep the key in your possession when the paver is not operating.
- Attach a “Do Not Operate” tag near the key switch while performing maintenance on the equipment.
- Never operate the engine while wearing a headset to listen to music or radio because it will be difficult to hear the warning signals.

- Always start the engine or operate the controls while you are seated in the operators seat.

Alcohol and Drug Hazard



Never operate the engine while under the influence of alcohol or drugs, or when ill.

Piercing Hazard



Avoid skin contact with high-pressure hydraulic fluid or diesel fuel spray caused by a hydraulic or fuel system leak such as a broken hydraulic hose or fuel injection line. High-pressure hydraulic fluid or fuel can penetrate your skin and result in serious injury. If you are exposed to high-pressure hydraulic fluid or fuel spray, obtain prompt medical treatment.

- Never check for a hydraulic fluid or fuel leak with your hands. Always use a piece of wood or cardboard. Have your authorized LeeBoy Dealer or distributor repair the damage.

Flying Object Hazard



Always wear eye protection when cleaning the LeeBoy Model 8500B Conveyor Paver with compressed air or high-pressure water. Dust, flying debris, compressed air, pressurized water or steam may injure your eyes.

Coolant Hazard



Wear eye protection and rubber gloves when handling engine coolant. If contact with the eyes or skin should occur, flush eyes and wash immediately with clean water.

Burn Hazard



Some of the paver surfaces become very hot during operation and shortly after shutdown.

- Keep hands and other body parts away from hot paver surfaces.
- Handle hot components with heat-resistant gloves.

CAUTION

The safety messages that follow have CAUTION level hazards.

Poor Lighting Hazard

Ensure that the work area is adequately illuminated.
Always install wire cages on portable safety lights.

Tool Hazard

Always use tools appropriate for the task at hand and use the correct size tool for loosening or tightening LeeBoy Model 8500B Conveyor Paver parts.

NOTICE

The safety messages that follow have NOTICE level hazards.

Any part which is found defective as a result of inspection or any part whose measured value does not satisfy the standard or limit must be replaced.

Always tighten components to the specified torque. Loose parts can cause LeeBoy Model 8500B Conveyor Paver damage or cause it to operate improperly.

Only use replacement parts approved by LeeBoy. Other replacement parts may affect warranty coverage.



Follow the guidelines of the EPA or other governmental agencies for the proper disposal of hazardous materials such as engine oil, diesel fuel and engine coolant. Consult the local authorities or reclamation facility.

Clean all accumulated dirt and debris away from the body of the paver and its components before you inspect the paver or perform preventive maintenance procedures or repairs. Operating a paver with accumulated dirt and debris will cause premature wear of paver components. Accumulated dirt and debris also hinders effective paver inspection.

Retrieve any tools or parts that may have dropped inside of the paver to avoid improper paver operation.

Dispose of hazardous materials in accordance with all applicable laws and regulations. Never dispose of hazardous materials by dumping them into a sewer, on the ground, or into groundwater or waterways.

If any alert indicator illuminates during paver operation, stop the engine immediately. Determine the cause and repair the problem before continuing to operate the paver.

SAFETY LABEL LOCATIONS

Safety Precautions

If your LeeBoy Model 8500B Conveyor Paver has been repainted, it is extremely important that all the decals referring to CAUTION, WARNING, and DANGER be replaced in their proper locations. The illustrations on this page will aid you in determining the proper locations; for additional help, you should refer to the

parts listing in the parts section of this manual and note the description column.

A description of location is provided below for each safety label. For additional instructions, contact your dealer see **Contact Information** in Section 3).

NOTE: It is the responsibility of the owner and operator to make sure that all safety labels are readable and located on paver as designated by LeeBoy.

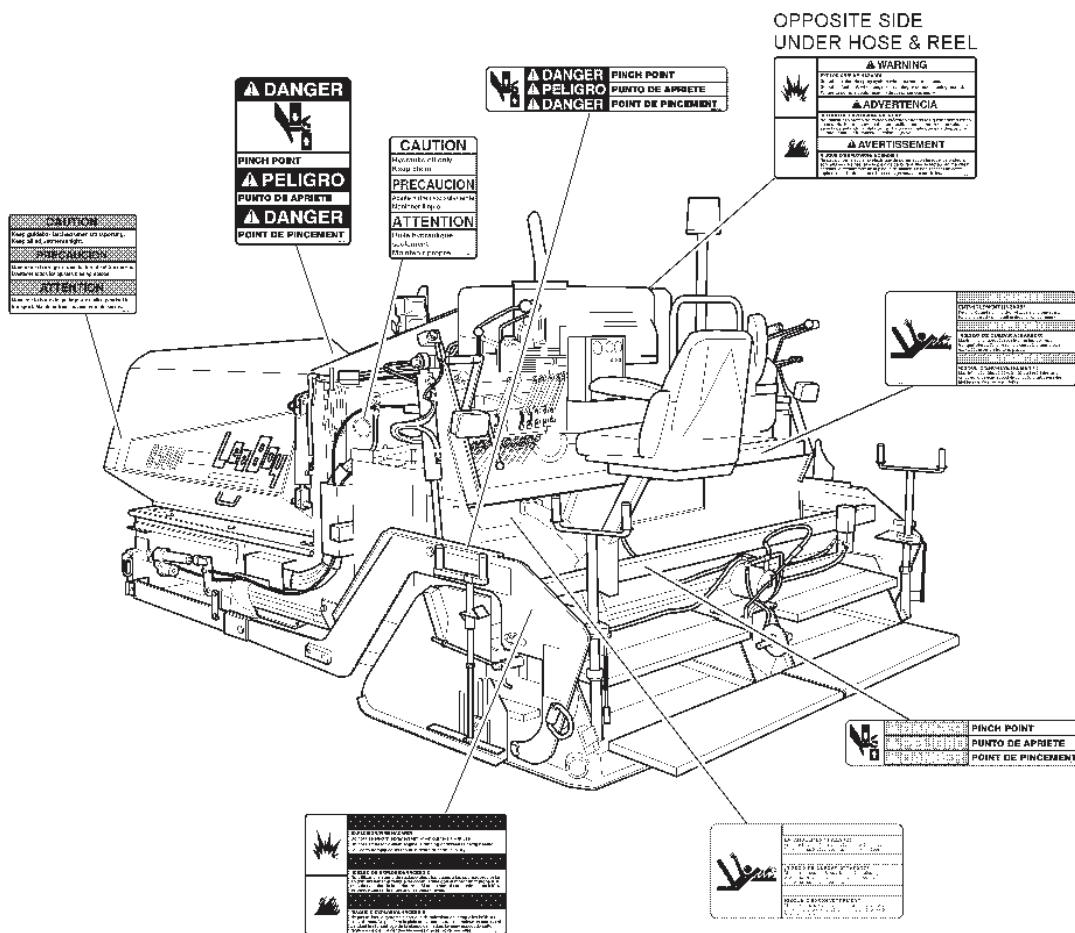

Conveyor Paver Safety Labels and Safety Label Locations

Figure 2-1

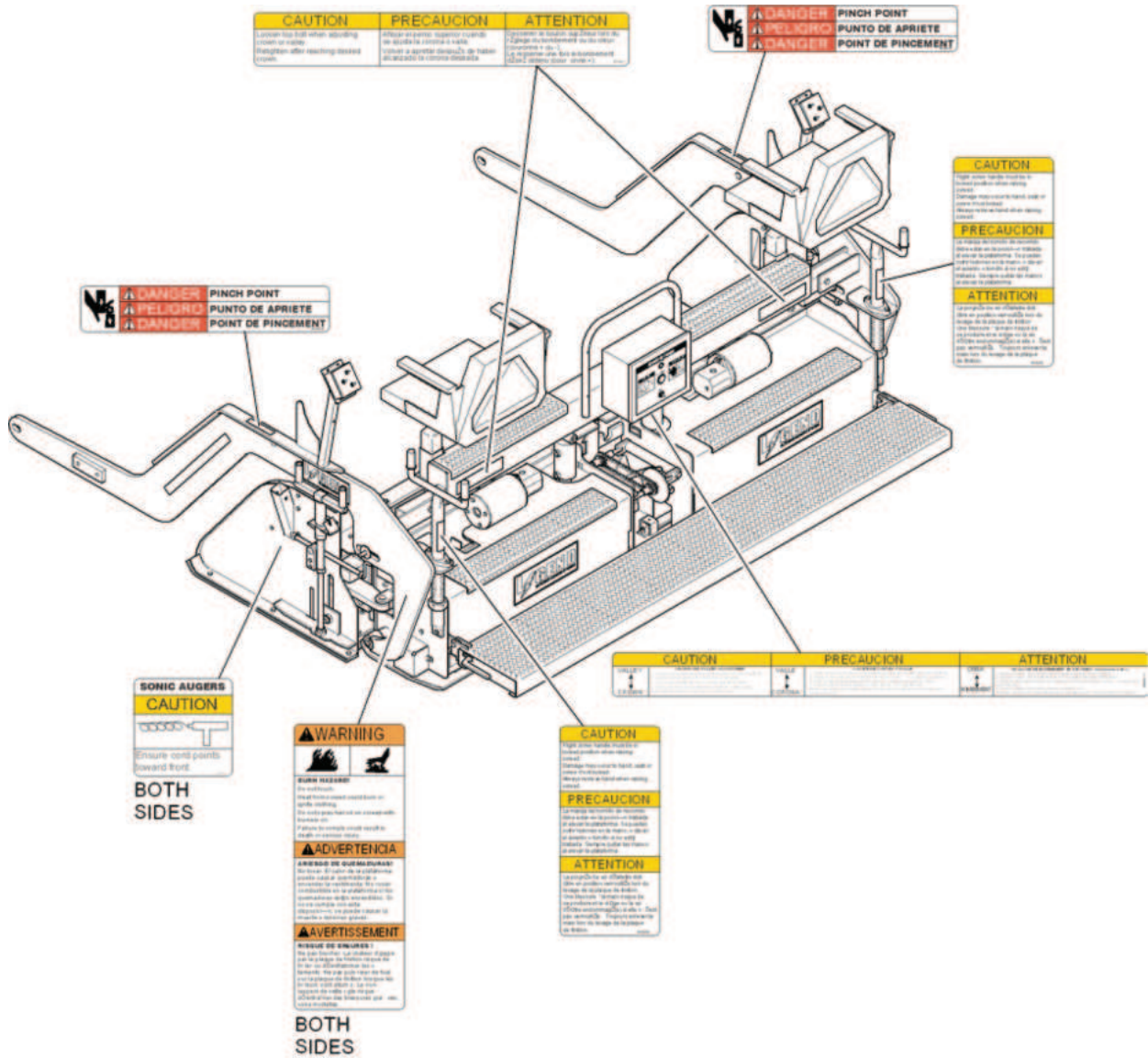

8500B Electric Screed Safety Labels and Safety Label Locations

Figure 2-2

NOTES



Section 3

GENERAL INFORMATION

	Page
General Information	3-1
Limited Warranty Policy	3-2
Warranty.	3-2
Limitations.	3-2
Items Not Covered	3-3
Other Limitations.	3-3
Contact Information	3-4
Record of Ownership	3-4
Nameplate	3-4

LIMITED WARRANTY POLICY

Warranty

1. Subject to the limitations, exclusions, and claims procedures set forth herein, LeeBoy warrants [to the first retail purchaser] that this product will be free from [substantial] defects in materials and workmanship during the warranty period.
2. If a defect in material or workmanship is found, your authorized LeeBoy Dealer is to be notified during the warranty period. LeeBoy and its authorized Dealer will repair or replace any part or component of the unit or part that fails to conform to the warranty during the warranty period.
3. The warranty period will begin on the initial start-up, training and delivery of the unit by the Dealer to the customer, and will expire after twelve (12) months following the delivery of the paver to the first retail purchaser. (See Dealer for additional warranty.)
4. Manufacturers' Warranties: Engines are warranted by their manufacturers and may have warranty coverage that differs from that of LeeBoy. LeeBoy does not warrant any engine.
5. Replacement parts furnished by LeeBoy are covered for the remainder of the warranty period applicable to the unit or component in which such parts are installed.
6. LeeBoy has the right to repair any component or part before replacing it with a new one.
7. All new replacement parts purchased by a LeeBoy Dealer will carry a six-month warranty.
8. This Limited Warranty is governed by the laws of the State of North Carolina.

THE FOREGOING WARRANTY IS EXCLUSIVE AND IN LIEU OF ALL OTHER EXPRESSED, STATUTORY AND IMPLIED WARRANTIES APPLICABLE TO UNITS, ENGINES, OR PARTS INCLUDING WITHOUT LIMITATION, ALL IMPLIED WARRANTIES OF MERCHANTABILITY OR FITNESS FOR ANY PARTICULAR USE OR PURPOSE OR AGAINST INFRINGEMENT.

Limitations

LeeBoy has no obligation for:

1. Any defects caused by misuse, misapplication, negligence, accident or failure to maintain or use in accordance with the most current operating instructions.
2. Unauthorized alterations.
3. Defects or failures caused by any replacement parts or attachments not manufactured by or approved by LeeBoy.
4. Failure to conduct normal maintenance and operating service including, without limitation, providing lubricants, coolant, fuel, tune-ups, inspections or adjustments.
5. Unreasonable delay, as established by LeeBoy, in making the applicable units or parts available upon notification of a service notice ordered by same.
6. Warranty Responsibility: The warranty responsibility on all engines rests with the manufacturer of the engine.
7. Warranty and Parts Support: LeeBoy may have support agreements with some engine manufacturers for warranty and parts support. However, LeeBoy does not warrant the engine.
8. This Limited Warranty sets forth your sole remedy in connection with the sale or use of the LeeBoy product covered by this Limited Warranty.
9. This Limited Warranty extends only to the first retail purchaser, and is not transferable.
10. In the event any portion of this Limited Warranty shall be determined to be invalid under any applicable law, such provision shall be deemed null and void and the remainder of the Limited Warranty shall continue in full force and effect.

Items Not Covered

LeeBoy is not responsible for the following:

1. All used units or used parts of any kind.
2. Repairs due to normal wear and tear or brought about by abuse or lack of maintenance of the Machine.
3. Attachments not manufactured or installed by LeeBoy.
4. Liability for incidental or consequential damages of any type including, but not limited to, lost profits or expenses of acquiring replacement equipment.
5. Liability for incidental or consequential damages of any type including, but not limited to, lost profits or expenses of acquiring replacement equipment.

Other Limitations

IN NO EVENT, WHETHER AS A RESULT OF BREACH OF CONTRACT OR WARRANTY OR ALLEGED NEGLIGENCE OR LIABILITY WITHOUT FAULT, SHALL LEEBOY BE LIABLE FOR SPECIAL, INCIDENTAL OR CONSEQUENTIAL DAMAGES INCLUDING, WITHOUT LIMITATION, LOSS OF PROFIT OR REVENUE, COST OF CAPITAL, COST OF SUBSTITUTED EQUIPMENT, FACILITIES OR SERVICES, DOWNTIME COSTS, LABOR COSTS OR CLAIMS OF CUSTOMERS, PURCHASERS OR LESSEES FOR SUCH DAMAGES. IN NO EVENT WILL WARRANTY COMPENSATION, OR OTHER DAMAGES AVAILABLE FROM LEEBOY, EXCEED THE PURCHASE PRICE OF THE PRODUCT.

CONTACT INFORMATION

For information regarding parts and repairs about your LeeBoy product, first contact the dealer you purchased your product from.

If you have a persistent problem your dealer is unable to resolve, contact LeeBoy directly.

Record dealer information in the space provided. For additional information about LeeBoy, please visit: www.leeboy.com.

Sales Representative: _____

Dealership Name: _____

Dealership Address: _____

Dealership Phone: _____

RECORD OF OWNERSHIP

Please fill out the following information and use it when you need to contact LeeBoy for service, parts or literature.

Paver Model Number: _____

Paver Serial Number: _____

Date of Purchase: _____

NAMEPLATE

Nameplate (**Figure 3-1**) contains the specific model number and serial number used to identify the components for any parts or service information.

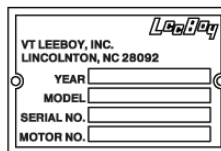
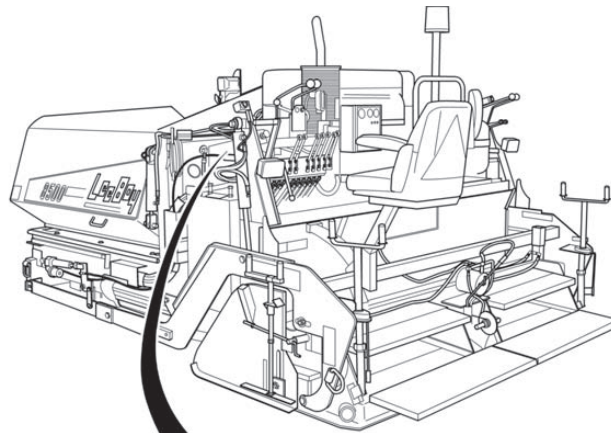

Nameplate Location

Figure 3-1



Section 4

SPECIFICATIONS

	Page
Specifications	4-1
General Information	4-2
Major Components	4-2
Hopper	4-2
Augers.	4-2
Operator Station.	4-2
Heating Components	4-2
Specifications	4-3
Dimensions	4-4
Torque Specs: Inch	4-5
Torque Specs: Metric	4-6



GENERAL INFORMATION

The descriptions and specifications provided in this section are applicable to the LeeBoy Model 8500B Conveyor Paver.

This section contains a description of how the major components operate. It also includes specifications for the major system components. Included in this section are paver weights, dimensions, performance, and major system specifications for the paver.

Engine

The LeeBoy Model 8500B Conveyor Paver uses either a Kubota, V3600-E3B 84.5 HP or CAT, C3.4 NA 83 HP four-cylinder engine to drive the hydraulic function pump and steering pump. The engine is mounted near the center of the paver and is accessible through several access doors in the engine cover.

A fuel lift pump mounted on the engine draws diesel fuel from the fuel tank. The fuel tank is mounted at the rear of the engine compartment.

An air cleaner is mounted on the top of the right-hand pump cover. The air cleaner removes fine particles such as dust, sand, chaff and lint from the air.

As air is taken into the air cleaner assembly, a cyclone type action deposits some of the fine particles in the evacuator mounted on the bottom of the air cleaner housing. The evacuator is held closed during engine operation by suction. When the engine is shut off the weight of the debris helps to open the rubber flaps allowing the debris to fall out. The rubber flaps can also be squeezed to open for cleaning.

Primary and secondary fuel filters remove contaminants from the diesel fuel before the fuel flows to the injection pump for injection into the engine combustion chamber.

A radiator mounted in front of the engine cools the engine. As coolant flows through the radiator, airflow from the engine-driven fan removes heat from the coolant.

Refer to the engine owner's Operation and Maintenance Manual for a complete description of the engine.

Hydraulic System

The hydraulic system includes four hydraulic pumps driven by the engine: 1) Left Drive Pump, 2) Right Drive Pump, 3) Conveyor Pump, 4) Auger and Cylinder Pump.

The auxiliary pumps is mounted on the rear of the drive pumps, to the right side of the engine, and driven by the drive pump output shaft. This gear type pump provides hydraulic flow to operate all the hydraulic cylinders used to control the paver functions.

Each auxiliary pump has it's own suction hose from tank. The conveyor pump will also charge the Left and Right Drive Pumps.

Torque Hubs

The paver drive system contains two torque hubs. The torque hubs provide power to propel the tracks.

Hopper

The hopper wings are hydraulically controlled to raise and lower. The hopper wings also hinge in and out to allow for more compact transportation. The hopper when fully open can hold a payload up to 7 tons.

Material in the hopper is moved toward the back of the paver to the screed by conveyors. The conveyor is activated at the operator platform and are controlled on and off with limit switches..

Augers

The Auger rotates clockwise (CW) to assist in moving material from the conveyors to the screed. The auger can be manually controlled at the operator platform on the paver or by the screed operator on the screed.

The auger can also be controlled automatically when the sonic auger system is installed and active. The sonic auger sensor mounted on the screed end gates detect the amount of material present and control the auger to keep the material flow constant.

Operator Platform

The operator platform allows easy and convenient control of most all functions of the paver and screed. The paver can be operated from either the left-hand or right-hand side depending on which control panel side is active and best suited to the working conditions.

Screed

The Screed is the last part of the paver that contacts the paved material. Operation of the screed is usually done by the screed operator. Paving material is fed from the hopper and conveyor to the augers to the front of the Screed. The Screed has hydraulically controlled extensions that move in and out to allow a wider paving base from 8 ft up to 15 ft.

Screed heating is accomplished by either LPG burners, or by electric heating elements mounted directly to the wear plates.

The hydraulically driven vibrators mounted on the main screed frame can be used to increase paving material compaction.

Electrical System

The electrical system is powered by a 12-volt battery mounted in the engine compartment located under the covers in the center of the paver forward of the operator's platform.

The battery produces 12 volts DC and maintains 1125 cold cranking amperes (CCA). An engine-mounted alternator capable of at least 60 amperes charging capacity keeps the battery charged during normal operation. The battery charge rate can be monitored using the voltmeter on the center operator dash panel.

Electrically heated pavers come equipped with a generator. The generator is mounted on the paver under the hopper floor near the right hand track.

The generator is hydraulically driven by the first section of the rear pump on the engine pump stack. When the paver is at full rpm, and the hydraulic system is at normal operating temperature, the generator should operate at a sufficient speed to produce between 220VAC and 240VAC.

All LeeBoy generators are equipped with an integrated generator speed control manifold. This manifold should not require adjustment, but if there is a need to fine tune the generator speed, there is an adjustment on the manifold (see **Generator Speed Tuning** in Section 7).

NOTICE Generator speed tuning should only be done by an authorized LeeBoy Dealer.

All output power from the generator is passed through the main breaker for safety. All output power is lost when this breaker is in the "tripped" or "off" position. The location of the generator main output breaker is shown in **Figure 6-22**.

The paver has heating controls to provide the necessary connection and control of the output power from the generator to the heating elements. It is necessary to maintain all components of the heating controls system in good working order to maintain safe and efficient screed heating.

The Heating Control or Distribution/Control Box is mounted near the middle of the screed and is easily accessible to the screed operator when a heating cycle is required.

There is a five second delay after the heat cycle is initiated before the actual electric load is sent to the heating elements from the generator. This delay is to allow the generator to reach optimal operating speed before the electrical load is required.

Once the heat cycle is started, a pre-programmed timer controls the amount of time for output power from the generator to go through the element connection supply plugs coming out of the bottom of the Heating Control Box to the heating elements.

Any element lead can be plugged into any supply plug under the heating control/distribution box. All six plugs are equally rated.

Each element is sized to fit properly in your screed, and provide sufficient power to heat your screed plate to a temperature that mix will not drag or stick to the lower surface of the screed plate.

To know that the element is correct, you should read a resistance between 28 ohms and 60 ohms (see **Testing Element Relays** in Section 7).

SPECIFICATION CHARTS

The specifications provided in this section are applicable to the LeeBoy Model 8500B Conveyor Paver. Included in this section are specifications for

paver weights, dimensions, performance, and torque values for both metric and standard inch fasteners.

⚠ CAUTION Replace original equipment only with LeeBoy approved components.

Table 4-1. Dimension Specifications (See Figure 4-1)

ITEM	SPECIFICATION
Overall Length	12' 4" (365 cm)
Overall Height	6' 6" (198 cm)
Overall Width (hopper wings in)	8' 6" (259 cm)
Overall Width (hopper wings out)	10' (305 cm)
Paver Weight (without screed)	15,700 lbs (7,121 kg)
Screed Weight	2,900 lbs. (1,315kg)
Basic Paving Width	8' (2.44m)
Maximum Paving Width	15' (4.57m)
Screed Plate Material	3/8" (9.5mm) AR400 Steel
Main Screed Wear Plate	15" (.38m)
Extensions Width of Wear Plate	7" (17.8cm)
Extensions Length	3'6" (1.07m)
Walkway Width	12" (30.5cm) W/Extension

Table 4-2. Performance Specifications

ITEM	SPECIFICATION
Travel Speed	240 FPM (0.73 KPM)
Paving Speed	140 FPM (0.37 KPM)
Coverage: Basic Screed Width	8' (2.44 m)
Coverage: Maximum Screed Width	15' (4.57 m)

Table 4-3. Kubota Tier 3 Engine Specifications

ITEM	SPECIFICATION
Manufacturer and Model	Kubota, V3600-E3B
Emission Regulation	Tier 3 / Stage III A
Type	Vertical 4-cycle Liquid Cooled Diesel
Number of Cylinders	4
Bore, Stroke, and Displacement	3.86" (98 mm) ; 4.72" (120 mm); 220.9 in ³ (3.62 L)
Combustion System	Direct Injection
Power Rating kW - HP	63.0 kW - 84.5 HP
Maximum Speed	2600 rpm
Fuel Filter Type	Kubota Diesel

Table 4-4. CAT Tier 3 Engine Specifications

ITEM	SPECIFICATION
Manufacturer and Model	CAT, C3.4 NA 83 HP
Emission Regulation	Tier 3 / Stage III A
Type	I-4, 4-Stroke-Cycle Diesel, Liquid Cooled
Number of Cylinders	4
Bore, Stroke, and Displacement	3.70" (94 mm) ; 4.72" (120 mm); 203 in ³ (3.33 L)
Combustion System	Direct Injection
Power Rating bkW - HP	62.0 bkW - 83.0 HP
Maximum Speed	2500 rpm
Fuel Filter Type	CAT Diesel

Table 4-5. Machine System Capacity Specifications

ITEM	SPECIFICATION	
	Kubota	CAT
Engine Lubrication Oil - Refill capacity	15.0 quarts (14.2 L)	10.6 quarts (10.0 L)
Engine Lubrication Oil - Pan capacity	13.9 quarts (13.2 L)	9.5 quarts (9.0 L)
Hydraulic Oil Reservoir	40 gal (151.40 L)	
Torque Hubs	32 oz. (0.355 L) each	
Fuel	20 gal (75.70 L)	
Propane	One (1) 20 lb tank	
Antifreeze	Glycol based, Red, Extended Life; 3.6 gal (13.8 L)	

Table 4-6. Electrical Specifications

ITEM	SPECIFICATION	
	Kubota	CAT
Battery	One, Maintenance Free	
Battery Ampere Hour Rating	680 CCA	
Battery Voltage	12 Volts	
Alternator Type and Voltage	12 Volt, negative ground	
Alternator Output Amperage	60 Amps	63 Amps
Alternator Fan Belt Tension	Automatic belt tension mechanism keeps serpentine belt under tension at all times	
Starter Voltage and Type	12 Volt, negative ground	

Table 4-7. Hydraulic Pressures Specifications

ITEM	SPECIFICATION
Drive	3700 PSI (255 Bar)
Conveyors	2400 PSI (165 Bar)
Augers and Cylinders	2400 PSI (165 Bar)



Table 4-8. Lubricant Specifications

ITEM	SPECIFICATION
Engine Oil	15W-40, API CH-4, CI-4
Hydraulic Oil	All Weather VG 32
Torque Hub	50 WT Gear Oil
Grease	Shell Avania EP Grease or Equivalent
Chain Lube	Chain Lube

Table 4-9. Screed Specifications

ITEM	SPECIFICATION
Extensions	Two 45 inch hydraulically operated extensions
Vibration	One hydraulic vibrator producing 3400 vibrations per minute
Crown/Valley	Adjustable, at least 2 inches of crown and 1-1/2 inches of valley
Extensions	Includes a level indicator
Propane Heat	Two (2) 54,000 BTU propane burners on main screed One (1) 54,000 BTU propane burner on each extension
Electric Heat (Option)	Two (2) Electric Heat Elements (3412 BTU/hr) on main screed One (1) Electric Heat Element (3412 BTU/hr) on each extension

DIMENSIONS

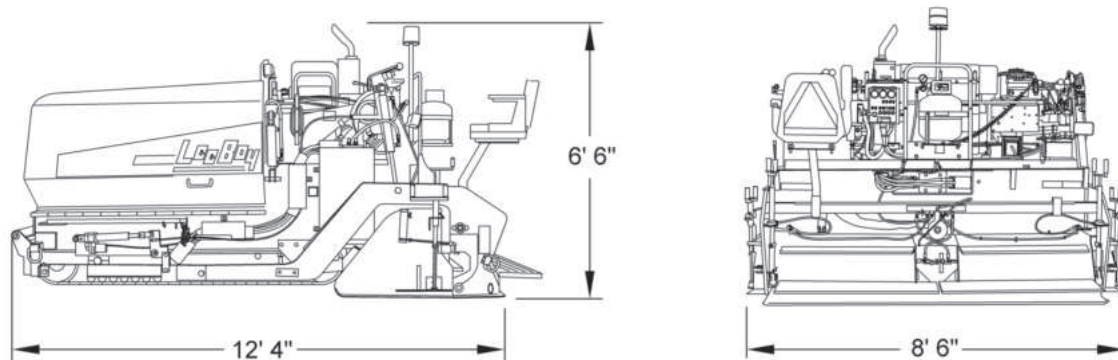

8500B Conveyor Paver Dimensions

Figure 4-1

TORQUE SPECS: INCH

⚠ WARNING The following Table lists torque values for standard hardware and are intended as a guide for average application involving typical stresses and machined surfaces. Values are based on

physical limitations of clean, plated and lubricated hardware. In all cases, when an individual torque value is specified, it should be followed instead of values given in this table.

⚠ CAUTION Replace original equipment with hardware of equal grade.

Table 4-10. Torque Specifications For Standard Inch Fasteners

SIZE	THREAD	CAPSCREWS: SAE GRADE 5				CAPSCREWS: SAE GRADE 8			
		TORQUE FT. LBS.		TORQUE N•m		TORQUE FT. LBS.		TORQUE N•m	
		Dry	Lubed	Dry	Lubed	Dry	Lubed	Dry	Lubed
1/4	20 UNC	8	6	11	9	12	9	16	12
	28 UNF	10	7	13	10	14	10	19	14
5/16	18 UNC	17	13	24	18	25	18	33	25
	24 UNF	19	14	26	20	27	20	37	28
3/8	16 UNC	31	23	42	31	44	33	59	44
	24 UNF	35	26	47	36	49	37	67	50
7/16	14 UNC	49	37	67	50	70	52	95	71
	20 UNF	55	41	75	56	78	58	105	79
1/2	13 UNC	75	57	100	77	105	80	145	110
	20 UNF	85	64	115	86	120	90	165	120
9/16	12 UNC	110	82	145	110	155	115	210	155
	18 UNF	120	91	165	125	170	130	230	175
5/8	11 UNC	150	115	205	155	210	160	285	215
	18 UNF	170	130	230	175	240	180	325	245
3/4	10 UNC	265	200	360	270	375	280	510	380
	16 UNF	295	225	405	300	420	315	570	425
7/8	9 UNC	430	320	580	435	605	455	820	615
	14 UNF	475	355	640	480	670	500	905	680
1	8 UNC	645	485	875	655	910	680	1230	925
	14 UNF	720	540	980	735	1020	765	1380	1040
1-1/8	7 UNC	795	595	1080	805	1290	965	1750	1310
	12 UNF	890	670	1210	905	1440	1080	1960	1470
1-1/4	7 UNC	1120	840	1520	1140	1820	1360	2460	1850
	12 UNF	1240	930	1680	1260	2010	1500	2730	2050
1-3/8	6 UNC	1470	1100	1990	1490	2380	1780	3230	2420
	12 UNF	1670	1250	2270	1700	2710	2040	3680	2760
1-1/2	6 UNC	1950	1460	2640	1980	3160	2370	4290	3210
	12 UNF	2190	1650	2970	2230	3560	2670	4820	3620



TORQUE SPECS: METRIC

⚠ WARNING The following Table lists torque values for standard hardware and are intended as a guide for average application involving typical stresses and machined surfaces. Values are based on

physical limitations of clean, plated and lubricated hardware. In all cases, when an individual torque value is specified, it should be followed instead of values given in this table.

⚠ CAUTION Replace original equipment with hardware of equal grade.

Table 4-11. Torque Specifications For Metric Fasteners

NOMINAL SIZE & PITCH	CLASS 8.8 [GRADE 5 EQUIVALENT]				CLASS 10.9 [GRADE 8 EQUIVALENT]			
	TORQUE FT. LBS.		TORQUE N•m		TORQUE FT. LBS.		TORQUE N•m	
	Dry	Lubed	Dry	Lubed	Dry	Lubed	Dry	Lubed
M4 x 0.7	2.27	1.70	3.07	2.30	2.27	2.31	4.17	3.13
M5 x 0.8	4.58	3.43	6.20	4.65	6.22	4.67	8.43	6.33
M6 x 1	7.75	5.83	10.5	7.90	10.60	7.97	14.3	10.8
M8 x 1.25	18.89	14.17	25.6	19.2	18.95	19.26	34.8	26.1
M10 x 1.25	39.11	29.52	53.0	40.1	53.87	40.59	73.0	55.0
M12 x 1.75	64.94	48.71	88.0	66.0	88.56	66.42	120.0	90.0
M14 x 2	103.32	77.49	140.0	105.0	140.22	107.01	190.0	145.0
M16 x 2	162.36	121.77	220.0	165.0	221.40	166.05	300.0	225.0
M20 x 2.5	317.34	236.16	430.0	320.0	428.04	321.03	580.0	435.0
M24 x 3	516.12	409.59	740.0	555.0	754.38	557.19	1010.0	755.0
M27 x 3	797.04	597.78	1080.0	810.0	1084.86	811.80	1470.0	1100.0
M30 x 3.5	1084.86	811.80	1470.0	1100.0	1476.00	1107.00	2000.0	1500.0



Section 5

COMPONENT LOCATION

	Page
Component Location	5-1
Location of Operation Panels and Controls	5-2
Main Dash Panel	5-4
Main Dash Panel (Continued).	5-6
Speed and Steering Control Levers	5-8
Hydraulic Controls	5-10
Paving Controls	5-12
Electric screed Operation Controls.	5-14



LOCATION OF OPERATION PANELS AND CONTROLS

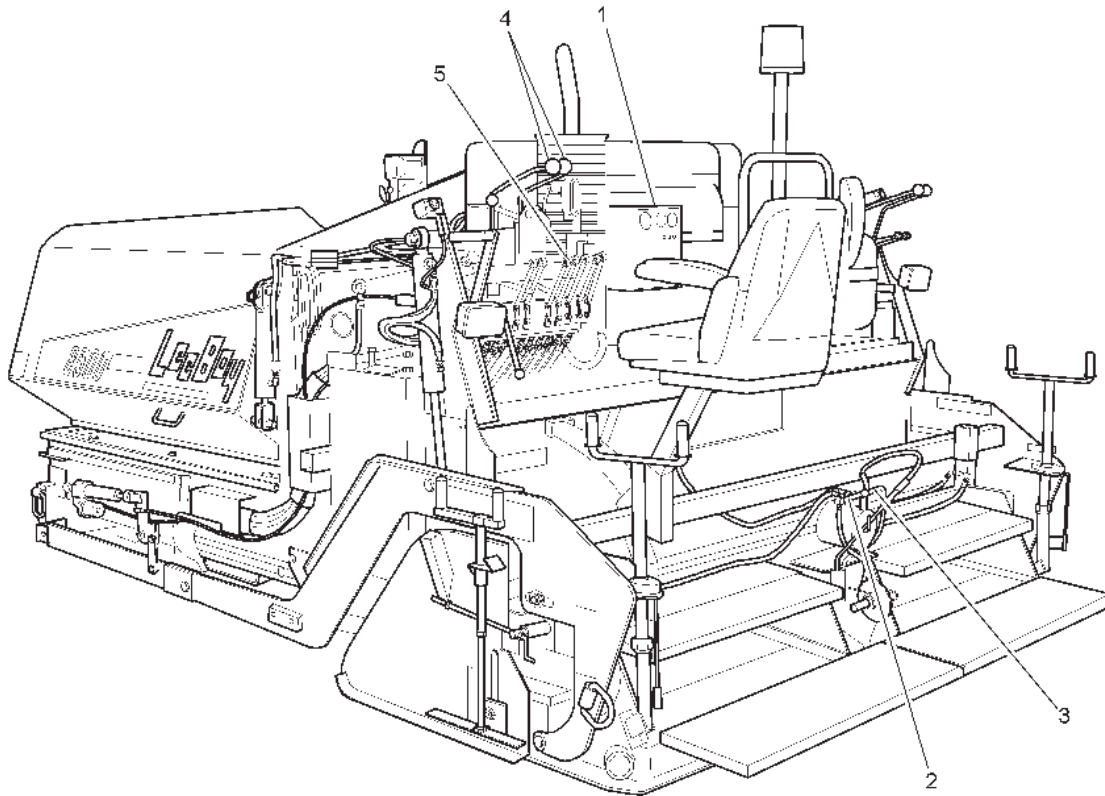

Location of Operation Panels and Controls

Figure 5-1

- 1 - Instrument Panel (dash)
- 2 - Left Burner Control
- 3 - Right Burner Control
- 4 - Steering and Speed Control Levers
- 5 - Hydraulic Controls

Table 5-1. Location of Operation Panels and Controls

ITEM NO.	CONTROL NAME	FUNCTION
1	Instrument Panel (dash)	Contains switches, indicators, and gauges (Figure 5-2)
2	Left Burner Control	Controls flow of propane to left screed burner
3	Right Burner Control	Controls flow of propane to right screed burner
4	Steering and Speed Control Levers	Levers control the speed and direction of paver travel (Figure 5-3)
5	Hydraulic Controls	Contains the hydraulic controls that operate the Screed and other Functions (Figure 5-4)

MAIN DASH PANEL

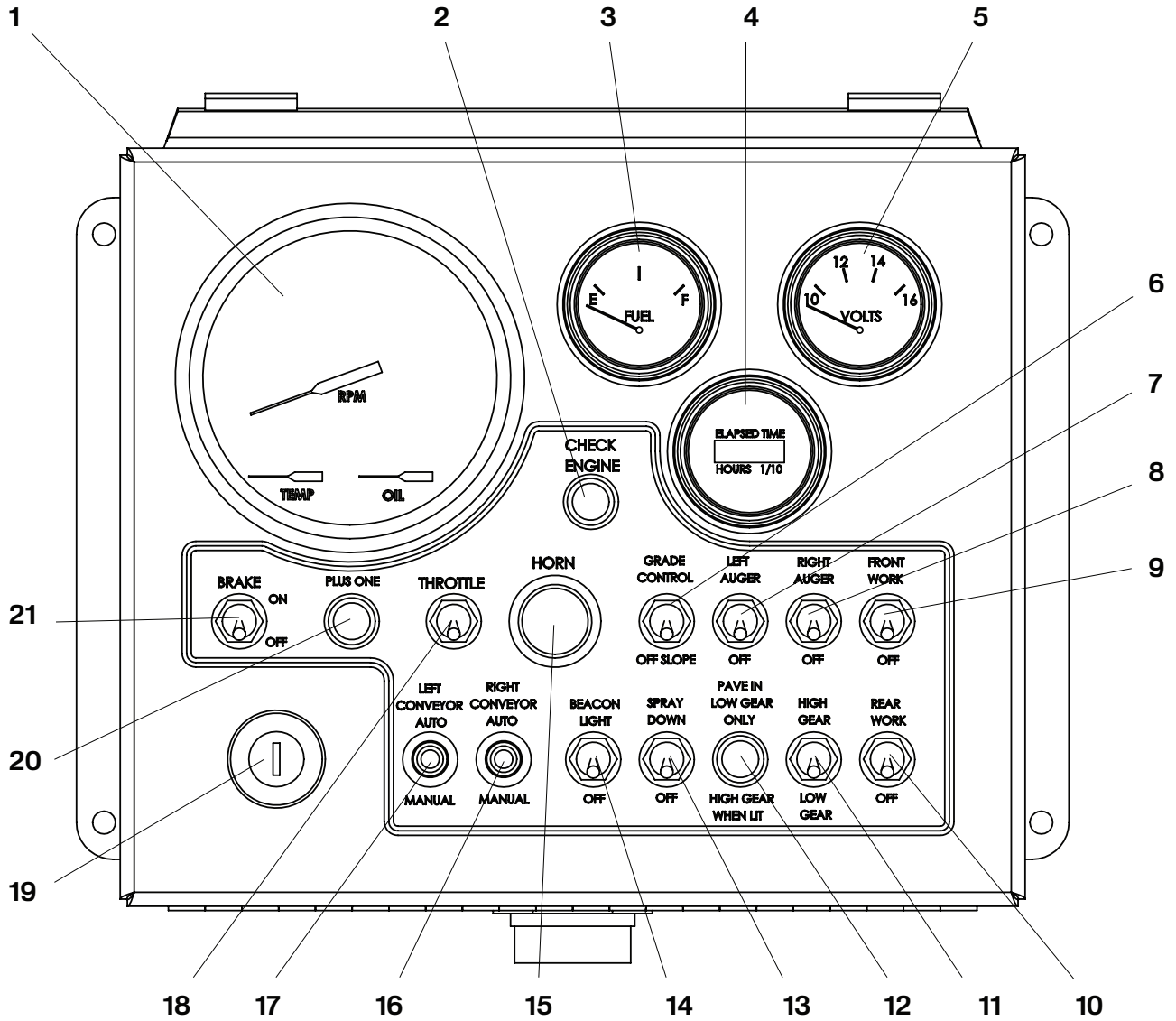

Main Dash Panel

Figure 5-2

- | | |
|--------------------------------|--------------------------------------|
| 1 - 3 in 1 Gauge | 2 - Check Engine Light |
| 3 - Fuel Gauge | 4 - Hourmeter |
| 5 - Voltmeter | 6 - Grade Control/Slope |
| 7 - Left Sonic Automatic Auger | 8 - Right Sonic Automatic Auger |
| 9 - Front Work Lights | 10 - Rear Work Lights |
| 11 - High/Low Gear | 12 - High/Low Light |
| 13 - Spray Down | 14 - Beacon Light |
| 15 - Horn | 16 - Right Conveyor Automatic/Manual |

Table 5-2. Main Dash Panel

ITEM NO.	CONTROL NAME	FUNCTION
1	3 in 1 Gauge: Tac, Oil, Water Temp	Shows engine RPM, engine lubricating oil temperature, and engine water temperature
2	Check Engine Light	Indicates an engine fault when illuminated. NOTE: Refer to engine operator's manual and an authorized LeeBoy Dealer.
3	Fuel Gauge	Indicates amount of fuel in fuel tank
4	Hourmeter	Meter monitors the working hours of the machine
5	Voltmeter	Indicates battery voltage
6	Grade Control/Slope	When switch is in the GRADE position, power is ON all the time.
7	Left Sonic Automatic Auger	Selects ON or OFF for the automatic operation of Left Auger. NOTE: In AUTO only - top position turns ON the Left Auger. Bottom position turns OFF the Left Auger.
8	Right Sonic Automatic Auger	Selects ON or OFF for the automatic operation of Right Auger. NOTE: In AUTO only - top position turns ON the Right Auger. Bottom position turns OFF the Right Auger.
9	Front Work Lights	Used to turn the work lights ON or OFF
10	Rear Work Lights	Used to turn the rear work lights ON or OFF
11	High/Low Gear	Used to change machine speed. Place switch in HIGH position for travel. (When in TRAVEL red 2-SPEED Light (Figure 5-2.12) will illuminate.) NOTE: High speed is only for traveling. Never pave in HIGH speed.
12	High/Low Light	Illuminates to indicate when HIGH/LOW switch is in the HIGH position
13	Spray Down	Used to turn on the Spray Down System. Set switch to SPRAY DOWN position to turn spray system on.
14	Beacon Light	Used to turn the beacon light on or off. Set switch to BEACON position to turn the Beacon light on.
15	Horn	Press button to sound the horn
16	Right Conveyor Automatic/Manual	Selects automatic or manual override for right conveyor. Center is OFF position. For Automatic operation set switch to AUTOMATIC position. MANUAL position provides override.

MAIN DASH PANEL (CONTINUED)

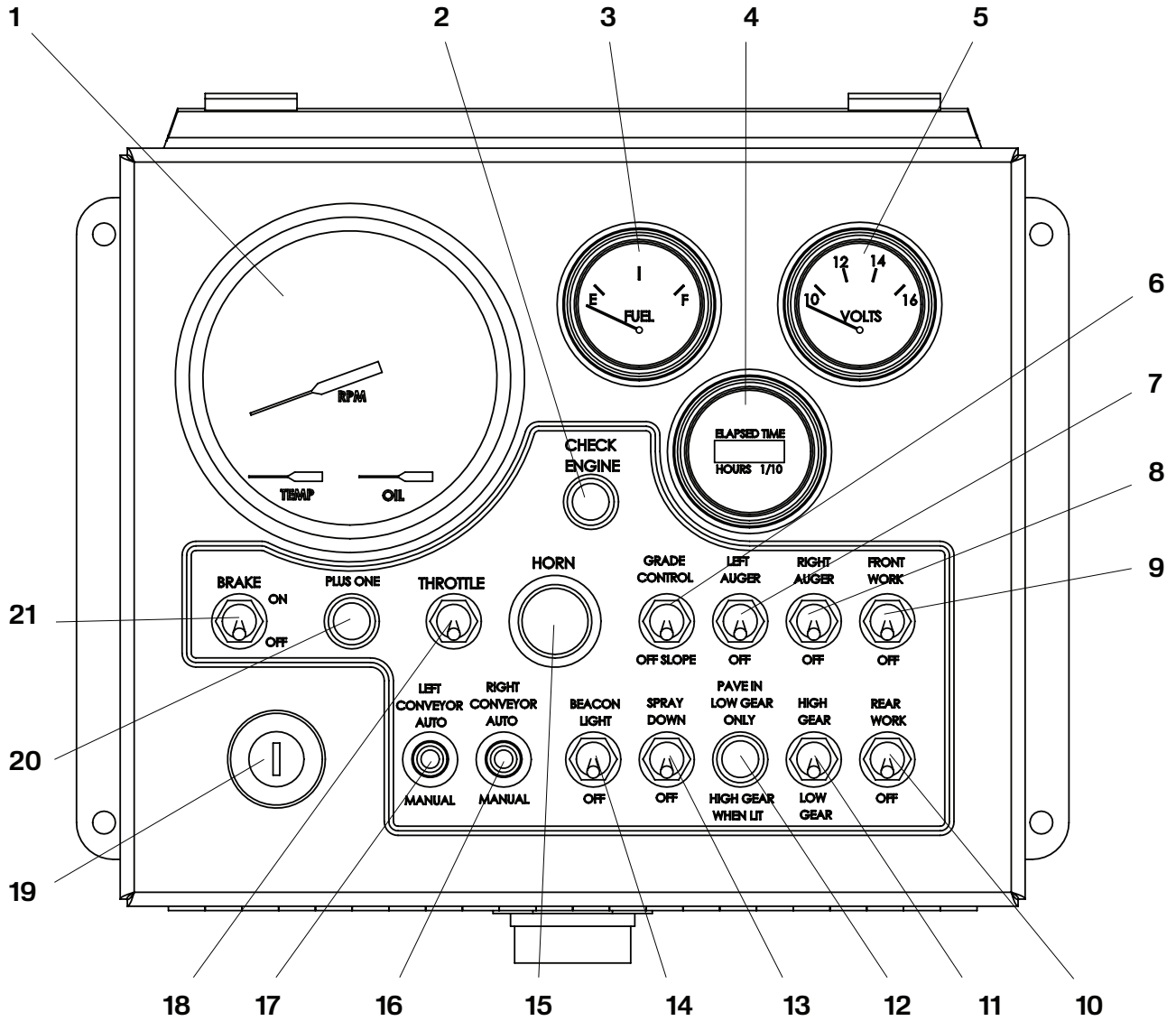

Main Dash Panel (continued)

Figure 5-2

- 17 - Left Conveyor Automatic/Manual
- 18 - Throttle Switch
- 19 - Ignition
- 20 - Plus One Indicator Light
- 21 - Parking Brake

Table 5-2. Main Dash Panel (Continued)

ITEM NO.	CONTROL NAME	FUNCTION
17	Left Conveyor Automatic/Manual	<p>Selects automatic or manual override for left conveyor.</p> <p>Center is OFF position.</p> <p>For Automatic operation set switch to AUTOMATIC position.</p> <p>MANUAL position provides override.</p>
18	Throttle Switch	<p>Used to set the engine RPM. Push THROTTLE up for higher RPM. Push THROTTLE down for lower RPM.</p>
19	Ignition	<p>Controls starting, stopping, and running of engine.</p> <p>Vertical position is OFF. Turn key right one notch for power. Red light will illuminate.</p> <p>Far right is the START position. After engine starts, release key, which will automatically return to the power position.</p> <p>NOTE: Engine will not start unless speed control is in NEUTRAL.</p>
20	Plus One Indicator Light	<p>Illuminates when there is a fault code in the Plus One system.</p> <p>See Maintenance section for more information.</p>
21	Parking Brake	<p>Sets brake in drive torque hub.</p> <p>Move switch to ON position to activate brake.</p> <p>Move switch to OFF to deactivate brake and allow paver movement.</p>

SPEED AND STEERING CONTROL LEVERS

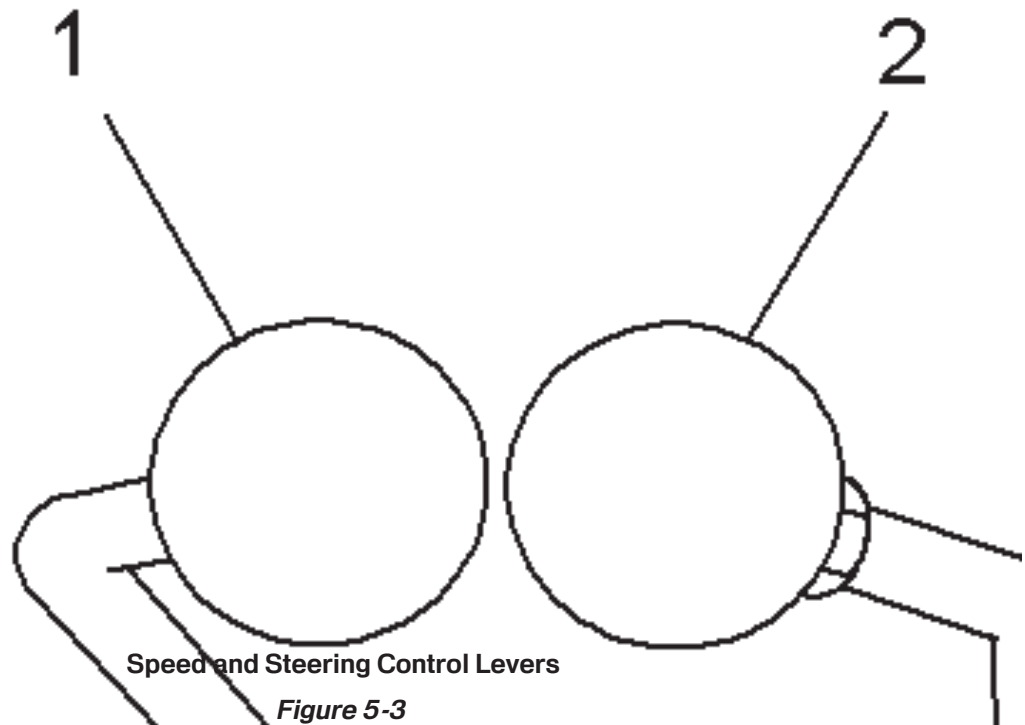

- 1 - Left Steering Handle
- 2 - Right Steering Handle
- 3 - Neutral Lock

Table 5-3. Speed and Steering Control Levers

ITEM NO.	CONTROL NAME	FUNCTION
1	Left Steering Handle	<p>Lever controls the speed and direction of the left side of the paver. Lever controls travel forward and reverse, and rate of travel.</p> <p>Moving lever forward moves left side of machine forward. The further forward the higher the speed.</p> <p>Moving lever backward moves the left side of machine backward. The further backward the higher the speed.</p>
2	Right Steering Handle	<p>Lever controls the speed and direction of the right side of the paver. Lever controls travel forward and reverse, and rate of travel.</p> <p>Moving lever forward moves right side of machine forward. The further forward the higher the speed.</p> <p>Moving lever backward moves the right side of machine backward. The further backward the higher the speed.</p>
3	Neutral Lock	<p>Mechanically locks the levers in neutral and engages neutral safety switch to allow engine start-up.</p>

HYDRAULIC CONTROLS

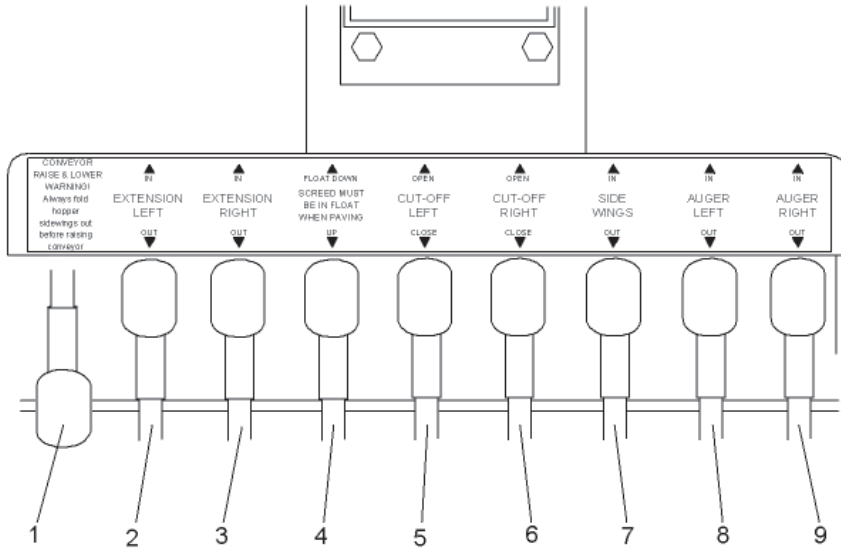

Hydraulic Controls

Figure 5-4

- 1 - Conveyor Raise/Lower (also Truck Hitch if equipped)
- 2 - Left Extension
- 3 - Right Extension
- 4 - Screed Raise/Float
- 5 - Left Cutoff Open/Close
- 6 - Right Cutoff Open/Close
- 7 - Side Wings
- 8 - Left Auger
- 9 - Right Auger

Table 5-4. Hydraulic Controls

ITEM NO.	CONTROL NAME	FUNCTION
1	Conveyor Raise/Lower	<p>Used to raise and lower the conveyor.</p> <p>Push the lever upwards to raise the conveyor (see WARNING).</p> <p>⚠ WARNING Always fold side wings on hopper out before raising conveyor. Place safety prop in place immediately.</p> <p>Pull the lever downward to lower the conveyor.</p> <p>NOTE: Lever also controls Truck Hitch (option) if equipped and selector valve is active (see Truck Hitch Attachment (Option) in Section 6).</p>
2	Left Extension	<p>Used to move the left extension in or out.</p> <p>Push the lever upwards to move left extension in.</p> <p>Pull the lever downward to move left extension out.</p>
3	Right Extension	<p>Used to move the right extension in or out.</p> <p>Push the lever upwards to move right extension in.</p> <p>Pull the lever downward to move right extension out.</p>
4	Screed Raise/Float	<p>Used to raise or float the screed.</p> <p>Push the lever upwards to lower the screed in FLOAT position.</p> <p>Once pushed forward, the lever locks in the FLOAT position.</p> <p>Pull back out of float and push the lever upwards again to raise the screed.</p> <p>NOTE: Screed must be in the FLOAT position when paving.</p>
5	Left Cutoff Open/Close	<p>Used to open or close the left cutoff.</p> <p>Push the lever upwards to open left cutoff.</p> <p>Pull the lever downward to close left cutoff.</p>
6	Right Cutoff Open/Close	<p>Used to open or close the right cutoff.</p> <p>Push the lever upwards to open right cutoff.</p> <p>Pull the lever downward to close right cutoff.</p>
7	Side Wings	<p>Used to move the side wings in or out.</p> <p>Push the lever upwards to move side wings in. (Never fold in with full hopper)</p> <p>Pull the lever downward to move side wings out.</p>
8	Left Auger	<p>Used to turn the left auger on or off.</p> <p>Pull the lever downward to turn the left auger on.</p>
9	Right Auger	<p>Used to turn the right auger on or off.</p> <p>Pull the lever downward to turn the right auger on.</p>

PAVING CONTROLS

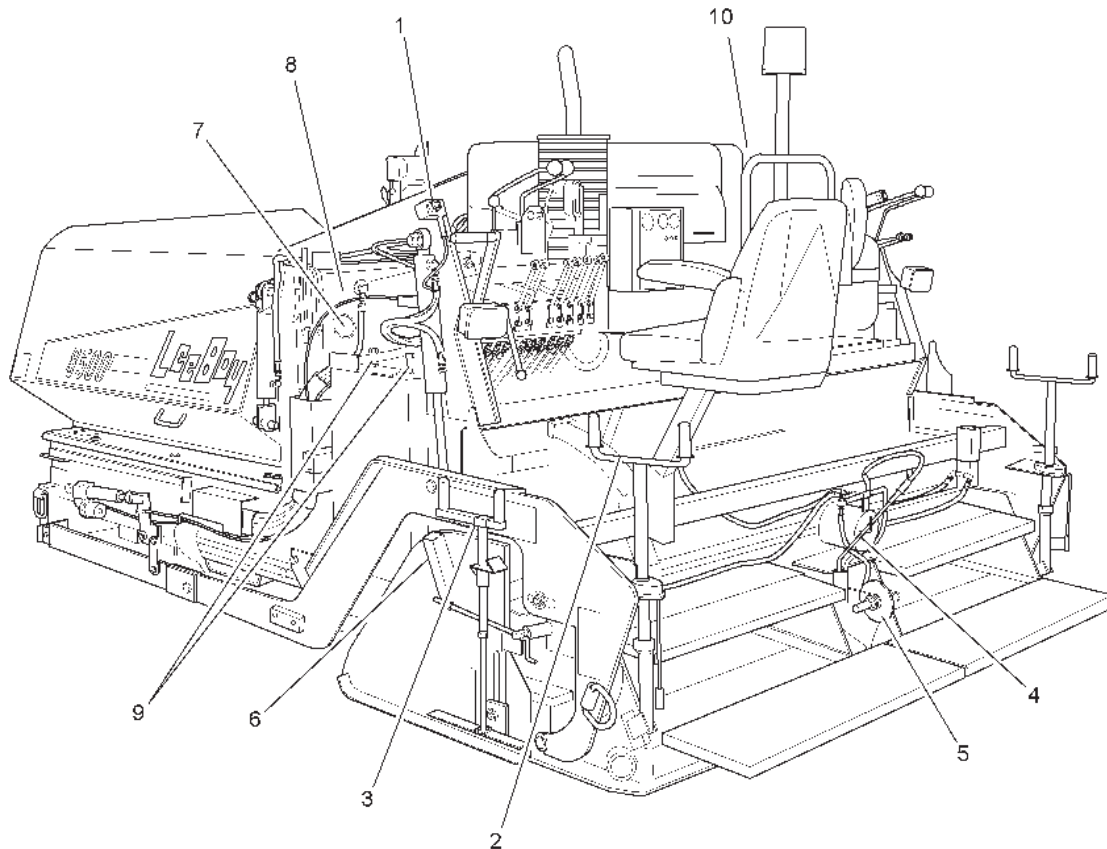

Paving Controls

Figure 5-5

- 1 - Auger Remote Control Head
- 2 - Flight Screw
- 3 - Depth Screw
- 4 - Igniter
- 5 - Crown and Valley
- 6 - Sonic Auger Sensor Mount
- 7 - Hydraulic Oil Temperature Gauge
- 8 - Oil Level Check Point
- 9 - Conveyor Drive Chain Adjustment
- 10 - Spray Down Hose

Table 5-5. Paving Controls

ITEM NO.	CONTROL NAME	FUNCTION
1	Auger Remote Control Head	Used for adjusting the height of material at End Gate. Connected to Sonic Auger Adjustment
2	Flight Screw	Sets the depth of the asphalt
3	Depth Screw	Controls the depth of the endgate
4	Igniter	Used to light the burners
5	Crown and Valley	Allows the screed to bend in the middle for crown and valley
6	Sonic Auger Sensor Mount	Mounting bracket for Sonic Auger
7	Hydraulic Oil Temperature Gauge	Monitors the temperature of the hydraulic fluid
8	Oil Level Check Point	Used to check oil level in hydraulic oil tank
9	Conveyor Drive Chain Adjustment	Screws with jam nuts for adjusting the conveyor drive chain tension
10	Spray Down Hose	Used to lubricate and keep asphalt from hardening on the machine

ELECTRIC SCREED OPERATION CONTROLS

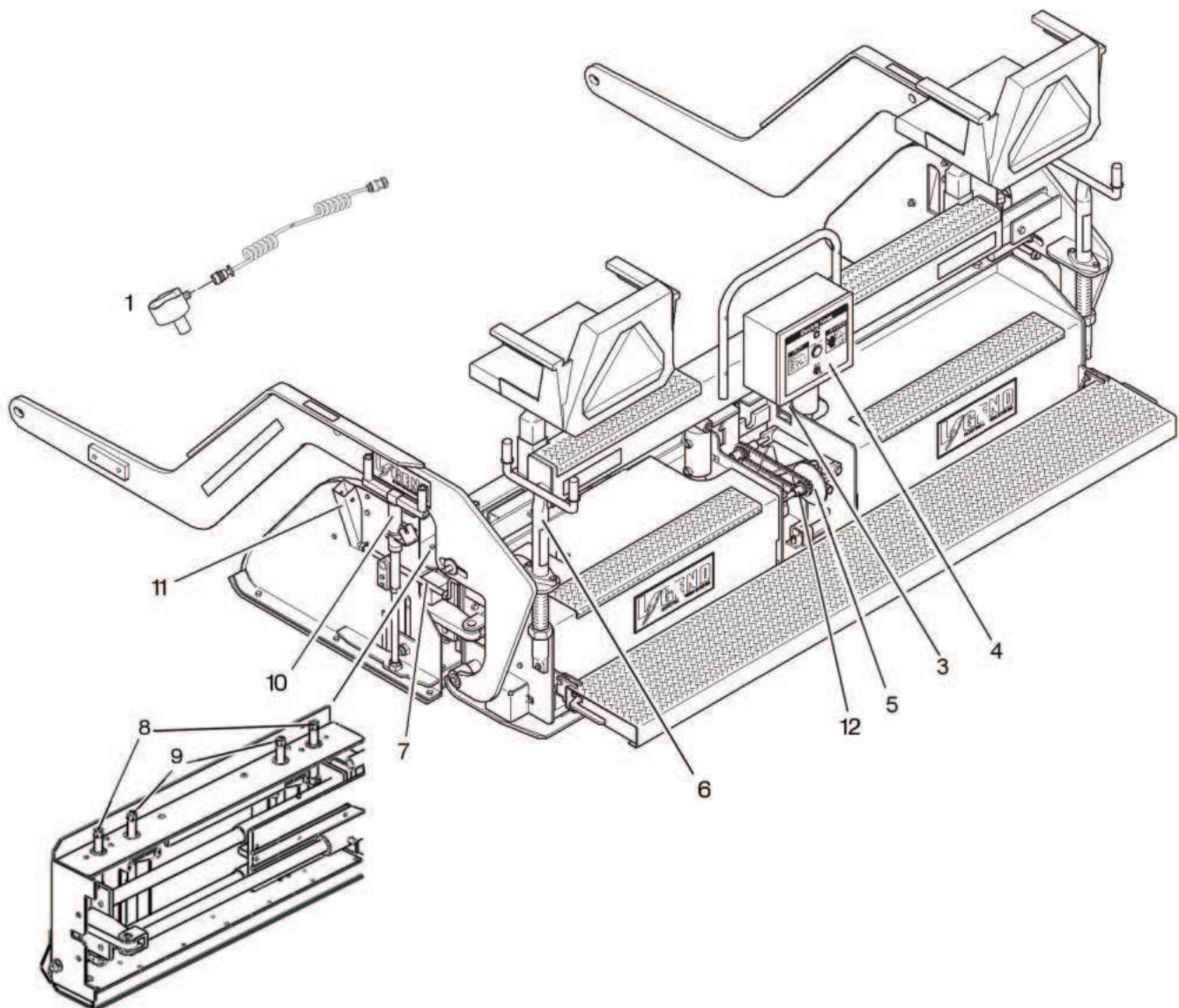

Electric Screed Operation Controls

Figure 5-6

- | | |
|-----------------------------|-------------------------------|
| 1 - Sonic Auger Sensor | 8 - Adjustment Screw |
| 3 - Screed Vibrator | 9 - Adjustment Screw |
| 4 - Heat Control Box | 10 - Depth Screw |
| 5 - Crown & Valley Adjuster | 11 - Sonic Auger Sensor Mount |
| 6 - Flight Screw | 12 - Crown & Valley Indicator |
| 7 - Tilt Screw | |

Table 5-6. Electric Screed Operation Controls

ITEM NO.	CONTROL NAME	FUNCTION
1	Sonic Auger Sensor	Connected to Sonic Auger Adjustment. For reference only.
3	Screed Vibrator	Provides vibration to screed frame for better mat compaction.
4	Heat Control Box	Has a power switch (Figure 6-8,1), a START HEAT button (Figure 6-8,2), and a heat cycle indicator light (Figure 6-8,3). Houses element breakers.
5	Crown & Valley Adjuster	Adjusts for positive crown or negative valley in wear plate.
6	Flight Screw	This screw controls the depth of the asphalt.
7	Tilt Screw	Used to adjust the tilt on End Gate.
8	Adjustment Screw	Adjusts the front of the extension to provide the best mat texture. Up or down and can level extension wear plate at wide widths. Double Adjuster is Optional (Figure 6-16).
9	Adjustment Screw	Adjusts the back end of the front of the extension. Tilt Rougher/Smoothen.
10	Depth Screw	This control sets the depth of the End Gate.
11	Sonic Auger Sensor Mount	Holds the Sonic Auger Sensor in proper position to maintain the proper height of augered material.
12	Crown & Valley Indicator	Shows the amount of crown in screed.

NOTES



Section 6 OPERATION

	Page
Operation	6-1
General Information	6-3
Pre-Start Inspection and Preparation	6-4
Starting The Engine	6-4
Preliminary	6-4
Engine Start-Up	6-4
Stopping the Engine	6-5
Paver Driving Instructions	6-5
General Control Information	6-5
Operating Information	6-5
Paver Operation	6-6
Conveyor Operation	6-6
Hydraulic Cutoff Gates Operation	6-7
Spray Down	6-7
Sonic Augers Operation	6-7
Auger Extensions	6-8
Electric Flight Screws Operation (Option)	6-9
Burner Ignition Procedure	6-9
Electric Heating Controls (Option)	6-11
Starting To Pave	6-12
Setting Screed To Pave	6-13
Setting Screed End Gates	6-14
Setting Screed Extensions	6-15
Mat Texture Adjustment	6-15
Unloading And Loading	6-16
Unloading	6-16



Loading	6-17
Tie Down Procedure	6-17
Electric Screed Heating System (Option)	6-18
Generator	6-18
Control Box	6-19
Cycle Timer	6-20
Element Relay	6-20
Element Breaker	6-21
Element Connections	6-21
Element Assembly	6-21
Truck Hitch Attachment (Option)	6-22
Umbrella (Option)	6-23

GENERAL INFORMATION

Before operating the LeeBoy Model 8500B Conveyor Paver, you must read the following safety information and review **Safety** in Section 2.

⚠ DANGER **Operation Hazard! Never allow anyone who is not properly trained to operate this paver. Only authorized personnel who are properly trained in the operation of the paver can operate the LeeBoy Model 8500B Conveyor Paver.**

⚠ DANGER **Operation Hazard! Do not operate a paver that requires repairs or scheduled maintenance. Put an information tag on the instrument panel that says "DO NOT OPERATE." Remove the key from the ignition switch. Repair all damage at once and perform routine maintenance. Minor damage can result in major system failure.**

SAFETY

- Verify there are no people, obstacles or other equipment near or in the line of travel of the LeeBoy Model 8500B Conveyor Paver before starting the engine.
- Work slowly in tight areas.
- Avoid steep hills if possible.
- Always look before changing the direction of travel.
- Always park the paver on solid, level ground in low range. If this is not possible, always park the paver at a right angle to the slope. Lower screed when parked.
- Use proper flags, barriers and warning devices, especially when parking in areas of traffic.
- Do not run engine in a closed building for long periods of time.
- Never open a valve to burner unless a flame is present. Heat screed for no more than 15 minutes.
- Make sure all valves are closed before propane is turned ON.
- Avoid leaving engine running without operator present.
- Never work on the paver with the engine running.
- Do not change the engine governor settings.
- Always replace damaged or lost decals.
- Disconnect battery cables when working on the electrical system or when welding on the unit.
- If battery needs a charge, be sure battery charger is off when making connections.
- Be sure the correct battery polarity is observed (negative (-) to negative (-) and positive (+) to positive (+), when connecting a battery charger or jumper cable.

PRE-START INSPECTION AND PREPARATION

To prevent costly down time, the LeeBoy Model 8500B Conveyor Paver should be checked thoroughly before each use. Use the list below to assist in checking out the paver.

1. Inspect paver. Have any malfunctioning, broken or missing parts repaired or replaced before using, including:
 - Hydraulic hoses/fittings
 - Pumps
 - Motors
 - Electrical wires and connections
 - Steps and supports
2. Check engine oil (refer to current engine operator's manual), hydraulic oil, torque hub oil and diesel fuel.
3. Check the engine neutral start switch (the engine should only start when the joystick FORWARD/REVERSE lever is in the NEUTRAL position) (**Figure 6-1**).
4. Check all electrical functions before distributing asphalt.
5. Check burner ignition (see **Burner Ignition Procedure** in Section 6).
6. Ensure operator's area is free of debris.
7. Ensure that all the instruction and safety labels are in place and readable. These are as important as any other equipment on the paver.
8. Read and follow all instruction and safety labels.
9. Ensure all covers and guards are in place.
10. Wear OSHA required safety equipment when running the paver.
11. Ensure paver is properly lubricated (see **Lubrication Chart** in Section 7).
12. Fill the fuel tank with the engine off.
⚠ WARNING Explosion Hazard! Never fill fuel tank near an open flame, when smoking, when the engine is running or when screed heat is on.
13. Clear auger and conveyors before starting engine.
14. Spray cleaning solvent or release agent on any part of the paver that comes in contact with asphalt (see **Spray Down** in Section 6).

STARTING THE ENGINE

Preliminary

1. Check fuel level, fuel lines, and tank for leaks.
2. Check crankcase oil level.

NOTICE Failure to maintain correct engine oil level is the greatest single cause of engine failures.

3. Check hydraulic oil level. Oil level is determined by petcock on hydraulic oil tank.
4. Make sure joystick (**Figure 6-1,1,2**) is in neutral position.
5. Refer to engine operator's manual for instructions when starting engine for the first time. Follow engine manufacturer's recommendations for fuel and oil.

Engine Start-Up

NOTE: Joysticks (**Figure 6-1**) must be in neutral position and Neutral Lock must be engaged to start engine.

1. Position joystick (**Figure 6-1,1,2**) to neutral.

NOTICE Do not operate the starter longer than 10-15 seconds. If the engine does not start, allow the starter to cool 2-3 minutes.

NOTICE The use of starting additives, such as ether, is not recommended.

2. Insert key into the ignition switch on instrument panel and turn key clockwise (CW) to start position.
3. If equipped with glow-plug option for cold weather start, turn key switch to the right to engage glow-plug.

NOTICE Do not engage glow-plugs for more than two (2) minutes at a time.

NOTE: Allow engine to warm up for several minutes before moving paver. The warm up will give the hydraulic oil time to warm, providing for more efficient operation. In cold weather let hydraulic oil warm to 50°F (10°C) or 60°F (16°C) before moving.

NOTE: For convenience, there is an extra key inside the switch box in case the original key is lost.

Stopping the Engine

1. Throttle back to idle by pushing the throttle switch down (**Figure 5-2,18**) until idle speed is reached.
2. Turn ignition key on instrument panel counterclockwise (CCW) to the OFF position and remove key.

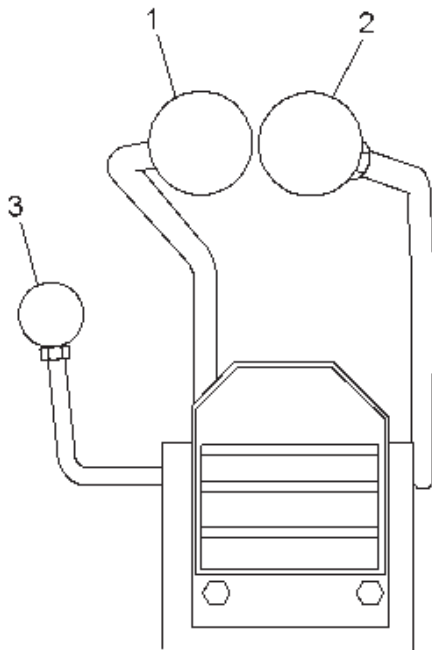

Speed And Steering Control

Figure 6-1

- 1 - Left Steering Joystick**
- 2 - Right Steering Joystick**
- 3 - Neutral Lock**

PAVER DRIVING INSTRUCTIONS

General Control Information

During operation, the paver is controlled by right and left-hand joysticks that control the track speed on each side.

Advancing the joysticks from the neutral position results in forward travel of the paver. As the joysticks are advanced further from neutral, paver speed increases.

Pulling the joysticks back from the neutral position reverses the paver travel. As the joysticks are pulled back further from neutral, paver speed increases.

Returning the joysticks to the neutral position stops the paver.

Operating Information

1. Start the paver. Allow the paver engine to warm up briefly.
2. To drive the paver forward, advance both joysticks evenly from the neutral position until the paver is moving at the desired speed.
3. Release Neutral Lock (**Figure 6-1,3**) by pulling lever toward operator.
4. To drive the paver in reverse, pull the joysticks back from the neutral position until the paver is moving in reverse at the desired speed.
5. To turn the paver left while moving in the forward direction, either advance the right-hand joystick further than the left-hand joystick or pull the left-hand joystick back. This causes the right side of the paver to move faster than the left-hand side and results in a left turn.
6. To turn the paver right while moving in the forward direction, either advance the left-hand joystick further than the right-hand joystick or pull the right-hand joystick back. This causes the left side of the paver to move faster than the right-hand side and results in a right turn.
7. Advancing either joystick while pulling back on the other joystick results in a tighter turn.
8. To stop the paver, return both joysticks to the neutral position and engage Neutral Lock (**Figure 6-1,3**).

PAVER OPERATION

1. Follow start-up procedures (see **Starting The Engine** in Section 6).
2. Position paver to start of mat. Adjust screed (see **Setting Screed To Pave** in Section 6).
3. When material starts to discharge from under screed, the SCREED LIFT RAISE/FLOAT switches on the dash should be set to the FLOAT position (One side only).
4. Open hopper wings into working position. When first starting to pave allow only a partial load of asphalt to enter the hopper.

NOTICE Never fold hopper wings fully in when hopper is full of asphalt.

5. Set the LEFT CONVEYOR and RIGHT CONVEYOR AUTOMATIC/MANUAL switches to the AUTOMATIC position and convey material back to screed. Run from one side only. Either the left operator's side or the right.

NOTE: Augers are not needed when paving a basic 8-foot pull.

6. Open cut-off gates under auger and start paving. Move slowly at first so adjustments can be made to screed.

CAUTION Never backup with cut-off gates open. Cut-off gates are designed to break away from cylinders when hitting a manhole or other hard object. This only occurs going forward not in reverse.

7. To prevent excessive handwork, about 2 to 3 ft. (0.6 to 0.9 m) from end of pull, Set the LEFT CONVEYOR and RIGHT CONVEYOR AUTOMATIC/MANUAL switches to the OFF position and set LEFT CUTOFF and RIGHT CUTOFF switches to the CLOSE position. Return paver back to starting position to begin next pull. Position and set screed endgate on joint side back to 0 ft. or flush with bottom of main screed. Repeat process as done in first pull.
8. The paver can operate using one side only. However, material from opposite side cannot be augered to the working side. The auger center cover prevents this. It is possible to leave both cutoffs shut and open the end gates on screed. This method is generally used in doing potholes and patching.

Conveyor Operation

The conveyor is a very important part of the paver and for this reason close attention should be given on integrating its operation into the total operation of the paver. Use the following procedure for operating the conveyor.

CAUTION Never use cylinder pressure to lower sides into place after lowering conveyor. This may bend sides or break the chains on the sides.

WARNING Never work on paver with engine running.

1. Before raising or lowering conveyor, unbolt hinges and fold side wings in and out by hand. The side wings have a double action motion causing the in and out movement.

NOTE: The engine must be shut off when lowering the conveyor.

2. When lowering conveyor, do not lower under pressure. Let the conveyor down with engine shut off by placing the CONVEYOR RAISE/LOWER switch in the LOWER (down) position with key switch on.

CAUTION Do not let the paver sit running with conveyors in automatic for any length of time. This may cause the hydraulic oil to over heat.

3. Spray the conveyor drive chains periodically. Spray several times a day with cleaning solvent or release agent (see **Spray Down** in Section 6).
4. When conveyors are running and cutoff gates are shut, there will be spillage the full width of the paver. This is normal. To help prevent this spillage, work conveyors manually when loading hopper and not paving.
5. Irregular movement of the conveyor indicates that a problem may exist with the conveyor chain. To eliminate this problem an adjustment to the conveyor chain may be necessary (see **Conveyor Flight Chain Adjustment** in Section 7).

NOTE: Check adjustments every 100 hours.

CAUTION Never work on conveyors with engine running.

NOTICE Never raise conveyor with asphalt in the hopper.

⚠️ WARNING Crush Hazard! Never work under conveyor without making sure that conveyor is being supported by safety prop and that all unauthorized personnel are clear of the area.

NOTICE Never let paver sit while conveyors are turning. If paver sits long enough, asphalt from conveyors can fill tracks and cause failure to the bearing or idler.

NOTICE To prevent flight chains from sticking inside of conveyor pans, lubricate them sufficiently at the end of the day.

Hydraulic Cutoff Gates Operation

The cutoff gates are one of the most important functions of the paver, when used properly. Cutoffs are used primarily to control the flow of asphalt to the screed. Cutoffs can be used when making passes, at the beginning and ending of each pass or pull.

NOTE: The cutoffs have been designed to break away if you accidentally hit a manhole or ridge. This feature will prevent excessive damage to cutoff (tack underneath will break).

⚠️ CAUTION Never backup with cutoff gates open. Cutoff gates are designed to break away from cylinders when hitting a manhole or other hard object. This only occurs going forward not in reverse.

NOTE: The RIGHT CUTOFF OPEN/CLOSE lever and the LEFT CUTOFF OPEN/CLOSE lever control the right and left cutoffs.

1. Move the handles upward to the OPEN positions to increase asphalt flow to the screed.
2. Move the handles downward to the CLOSE positions to decrease asphalt flow to the screed.

Spray Down

Always spray down the LeeBoy Model 8500B Conveyor Paver before using.

The spray down on your paver is used to spray cleaning solvent or release agent on any part of the paver that comes in contact with the asphalt. Buildup of asphalt will cause damage to components. Spray all areas of the paver that have direct contact with asphalt.

⚠️ WARNING Fire Hazard! Never spray cleaning solvent or release agent on or near a screed heating element that is hot or being heated or on or near any open flame or source of ignition. Cleaning solvent and release agent could ignite causing serious personal injury.

NOTE: When using spray down, consider the environment and do not allow cleaning solvent to run onto the ground.

1. Pull out the amount of hose needed and set SPRAY DOWN switch to SPRAY DOWN (up) position. Squeeze the wand handle and spray. Release wand handle when done spraying.
2. After spraying, set the SPRAY DOWN switch to the OFF (down) position and let the hose wind back up.

Sonic Augers Operation

The sonic augers are most often used when paving 9 or 10 ft. (2.7 or 3 meters) where augers are capable of running material over top of endgates, causing extra handwork. The sonic auger gauges the amount of material that is in the extensions.

⚠️ CAUTION Never run augers when paving 8 ft. (2.4 m) wide.

NOTE: An operator can operate the Auger from either side standing on or sitting in the Low Deck position.

1. Set the LEFT AUGER and RIGHT AUGER automatic toggle switches on the main dash to the ON position.
2. Pull the auger levers to ON to fill the end gates.. The sonic will turn the auger OFF and ON, automatically. To override the automatics, the toggle switches must be set to MANUAL.

NOTE: The sonic auger adjustment dial adjusts the amount of material needed in AUTOMATIC setting only.

3. Adjust height of material at endgate with the sonic auger adjustment (**Figure 6-2,1**). Turn the dial to keep the extension full. Be careful not to over run the extension with the material.

NOTE: When running material through augers manually, try to pave so material flow to extension is adequate and maintained.

NOTICE To prevent hydraulic oil from overheating, turn conveyor and augers OFF while waiting on material or hand work.

4. When paver stops, set the LEFT AUGER and RIGHT AUGER switches on the dash to the OFF (center) position and push auger levers to OFF.

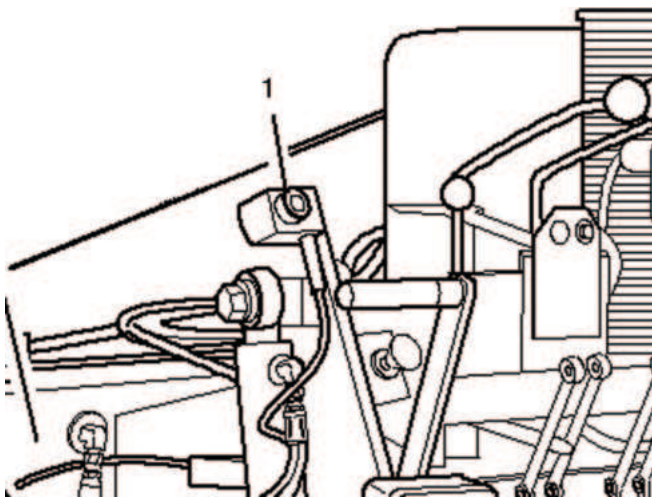

Sonic Auger Height Adjustment

Figure 6-2

1 - Adjustment Dial

Auger Extensions

The auger extensions should be attached to the main auger to increase the flow of asphalt. This makes it possible to lay asphalt at a higher rate. To attach the auger extensions proceed as follows:

NOTICE Left and right auger extensions must be installed on the correct side of the paver.

1. Identify the right and left auger extensions by observing the L (left) or R (right) on the end of the auger extension shaft (**Figure 6-3**).
2. After identifying the right and left auger extensions, extend the screed extension fully as follows:

WARNING Engine must be shut off to prevent possible injury when attaching auger extensions.

3. Shut off engine.
4. Remove bolt, nut cap on end of main auger.
5. Attach the correct side auger extension to the main auger with hardware just removed.
6. Secure end of extension auger to main auger.
7. Install guard (**Figure 6-3,1**). Make sure extension auger is running flat. If not, adjust with two hex nuts (**Figure 6-3,4**).
8. Grease at end cap (**Figure 6-3,3**).
9. Repeat this procedure for opposite side.

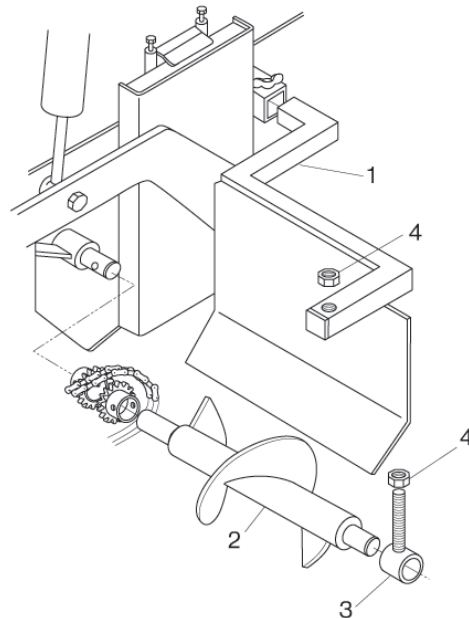

Auger Extensions

Figure 6-3

Electric Flight Screws Operation (Option)

The electric flight screw is an added convenience to the operator. A gauge is located on both sides of the paver. These gauges will provide the operator with quick reference to the location of the electric screw. Refer to **Figure 6-4** and use the following procedures:

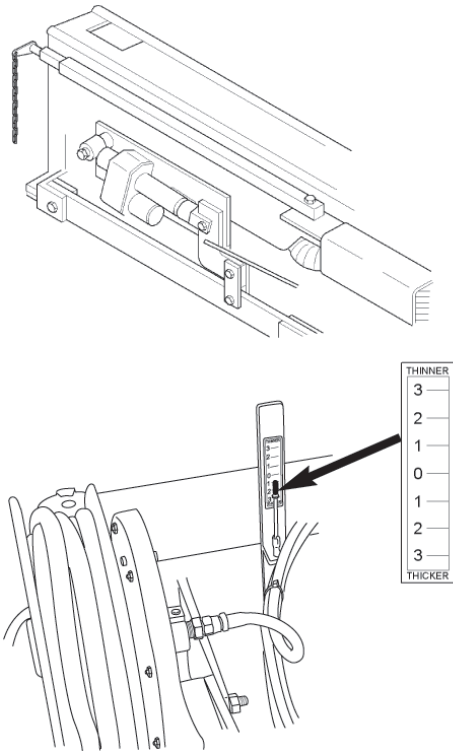

Flight Screws And Screed Height Gauges

Figure 6-4

1. Before paving, center the electric flight screws by referring to the screed elevation gauge on each side of the paver. Raise or lower until rod end of cable is flush with "0" on decal.
2. While paving, refer to both gauges and make minor adjustment to the screed by using the electric flight screw.

NOTE: Grade switch must be ON and lever in forward position to work remote switch.

Burner Ignition Procedure

⚠ WARNING Propane gas used to heat the screed is volatile and combustible. Use extreme care and follow the instructions.

NOTE: Heating the screed helps prevent hot mix from sticking to the cold screed plate and produces a smooth, tight mat surface. Heating should not only be performed at the beginning of the job, but also if the paver is idle for a long time between loads (allowing screed plate to cool).

The following procedure will provide the necessary steps in manually lighting the burners. It is important to remember that propane is a volatile and combustible gas and for this reason safety should be a major consideration. When treated with respect the propane will not present a problem. Follow the procedures below and refer to **Figure 6-5**, **Figure 6-6**, and **Figure 6-7** as required.

1. Turn OFF all burners valves at center of screed (**Figure 6-6,1,2,3**) and on both right and left side extensions (**Figure 6-7,3**).
2. Turn main propane valve ON (**Figure 6-5,1**) and set regulator for 15 lbs. (1 bar) (**Figure 6-5,3**).

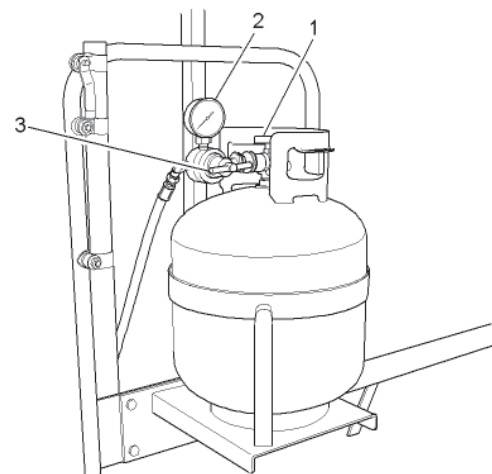

Propane Tank With Regulator

Figure 6-5

- 1 - Propane Tank Open/Close Valve
- 2 - Gauge
- 3 - Regulator

3. Ignite burner (**Figure 6-6,4**) with striker.

NOTE: Use ignitor burner (**Figure 6-5,4**) to light main burners manually.

⚠ WARNING Never open a valve to a burner unless flame is present. A buildup of unburned gas could result in a gas explosion.

4. Hold ignitor burner at end of main burner. To light main burner turn burner valve ON (Figure 6-6,1,2).

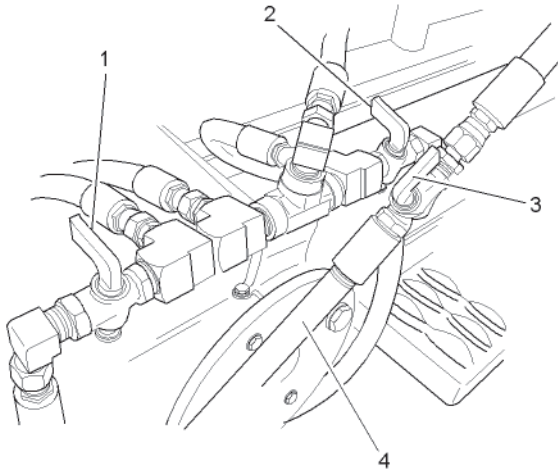

Burner Valves

Figure 6-6

1-3 - Burner Valves

4 - Ignitor Burner

5. Repeat procedure in step 4 for opposite side.
6. The extension burners are held in position to the screed with a quick coupling connection. Remove the extension burner from quick coupling connector and light (Figure 6-7).

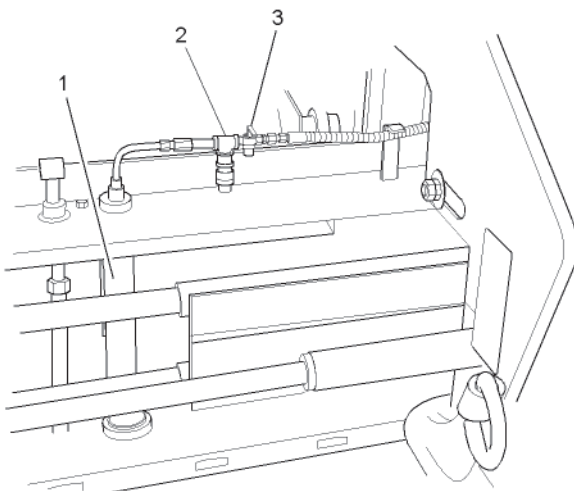

Extension Burner Quick Coupling Connector

Figure 6-7

To extinguish the burners:

1. After screed has heated for about fifteen (15) minutes, turn main tank valve off (Figure 6-5,1).
2. Once flame goes out completely, turn the burners off by rotating the burner valves (Figure 6-6,1,2,3) to the OFF position.

NOTE: If paving on a cool windy day, it may be necessary to maintain low heat on the screed. To accomplish this reduce the pressure on the propane tank (Figure 6-6,2) from 15 lbs. (1 bar) to 2 lbs. (0.14 bar). This will provide a low even heat that will not harm the screed. Do not attempt to regulate the burner with the burner valve.

NOTICE Too much heat for too long can warp screed plate, cause extensions to lock up, and cause mat texture problems. A warped screed plate should be replaced.

NOTICE If extension lock up occurs, let unit cool before forcing in or out.

Electric Heating Controls (Option)

LeeBoy Model Legend Electric Screed System is very easy to operate, and requires very little maintenance. The system consists of a hydraulically driven generator mounted on the paver, which feeds power to a distribution/control box mounted on the screed. This box is mounted near the middle of the screed and is easily accessible to the screed operator when a heating cycle is required.

The control box is where you will select the heating function before you begin to pave (Figure 6-8).

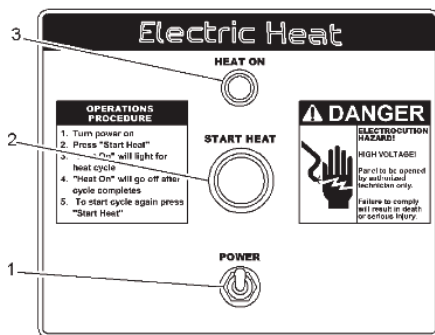

Electric Heat Control Box

Figure 6-8

- 1 - Power Switch
- 2 - Start Heat Button
- 3 - Heat On Indicator Light

The control box has a power switch (Figure 6-8,1), a START HEAT button (Figure 6-8,2), and a heat cycle indicator light (Figure 6-8,3). Under normal operation, the operator will flip the power switch up to the POWER position, and depress the START HEAT button. During normal usage, there are no other controls for operating the heat system.

To operate the screed heating system:

1. Start the paver and bring the engine to normal operating temperature as outlined in the paver manual.
2. Set the throttle on the paver to normal operating speed (approximately 1750 to 2000 rpm).

NOTE: Throttle positions of one half to less than full will still produce screed heat, but at a reduced rate and temperature. Do not run paver at less than half throttle while using electric screed heat.

NOTICE Do not run heating elements and auxiliary operations, such as augers, at the same time for extended periods over 1/2 hour. Generator and heating element damage will occur.

3. Flip the power switch (Figure 6-8,1) to the ON position.
4. Press the START HEAT (Figure 6-8,2) button.

NOTE: There is a five second delay after the heat cycle is initiated before the actual electric load is sent to the heating elements from the generator. This delay is to allow the generator to reach optimal operating speed before the electrical load is required.

5. The heating cycle will begin, and the HEAT ON (Figure 6-8,3) light will illuminate.

NOTE: The HEAT ON light (Figure 6-8,3) will stay on as long as the elements are heating the screed plates. Once the heating cycle is complete, the HEAT ON light will go out.

6. If the heat cycle has completed and the screed plates still require a higher temperature, restart the system by pressing the START HEAT (Figure 6-8,2) button again. The system will run for the set time once more.

NOTE: If the heat system is running, and the operator presses the START HEAT (Figure 6-8,2) button during a heating cycle, the heat will continue to operate normally, and the time cycle will re-set to beginning of the cycle. This will not hurt the system, and may be useful on cooler days to make the screed heat system run longer than normal without stopping.

Once the heating function has been enabled, the distribution/control box will apply electrical power to the heating elements and the heating cycle will begin. The heating cycle is timed to optimize the heat generated at the screed plates.

NOTE: The factory time setting for the heating cycle is 30 minutes. This will be sufficient in most circumstances to generate enough heat to begin the paving process without screed heat problems.

NOTE: The temperature that the screed plates reach will depend in part on the outside ambient temperature.

Operation

To help the screed heating system operate most efficiently:

- Ensure that engine RPM is at normal operating speed (approximately 1750 to 2000 rpm).
- Raise screed plate approximately 1 to 2 inches off the ground when just heating screed at start of project.
- Do not raise screed fully, allowing more wind under the screed plate while heating.
- Set the screed directly on a fresh mat of hot asphalt while running the heating system, allowing the heat of the asphalt to help heat the screed plate.

STARTING TO PAVE

The LeeBoy Model 8500B Conveyor Paver is capable of placing bituminous base, binder and surface courses, lime or Portland cement stabilized sub-base and graded aggregate materials up to a thickness of 6 in (20 cm).

The paver has a production rate of approximately 250 tons per hour.

The paver is equipped with electric and manual thickness controls and an 8 ft to 15 ft (2.8 m to 4.5 m) wide screed. The paver can handle everything such as driveways and small parking lots to large parking areas and secondary roads.

Before starting to pave, keep the following points in mind:

1. Plan the project so that the narrowest passes are first, (the basic width of the paver) leaving the widest pass until last.
2. Make sure to use a reference guideline. This can be a curb, gutter, adjacent mat or a string line. It is important that the first pass be straight. It will be the guideline for the following passes. Use the guide bar gauges as shown in **Figure 6-9**.

NOTICE Never run the paver through a pile of mix that has been dumped in front of the paver. Not only will this effect the level of the mat being laid but damage may result.

3. It is the operator's responsibility to guide the truck up to the paver and signal the driver when and how much to dump into the hopper. Truck drivers must maintain a light pressure on truck brakes to keep truck from dumping material on the roadway.

NOTE: If the paver is equipped with a truck hitch, the truck driver will not be required to maintain light pressure on the brake. Refer to the paragraph **TRUCK HITCH ATTACHMENT** in this chapter for using the truck hitch.

4. Always pave in low range.

WARNING Before starting forward with paver make certain that no one is in front of the paver.

CAUTION Avoid low hanging limbs, power lines, and other foreign objects that can endanger crew or paver.

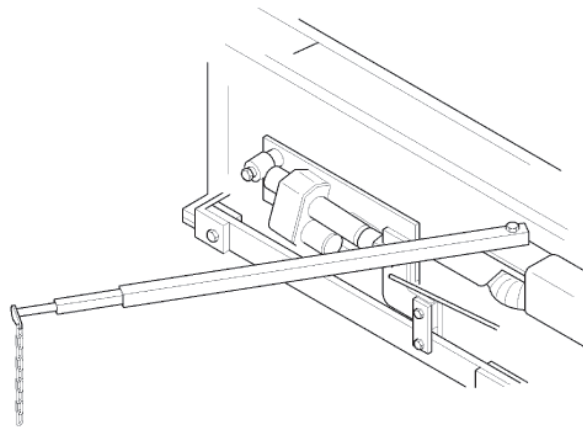

Guide Bar Gauges

Figure 6-9

Setting Screed To Pave

1. Move to the starting position.
2. Extend the screed to the desired width.
3. To set depth, place screed on starter blocks (Figure 6-10).

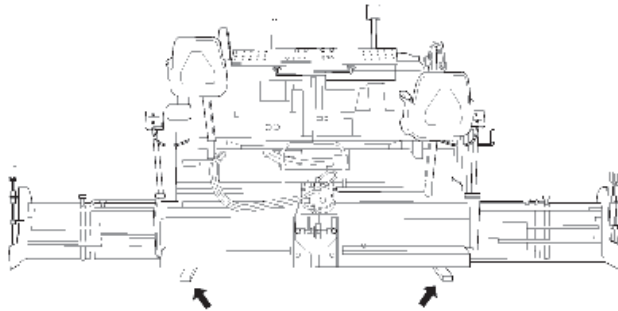

Starter Blocks

Figure 6-10

4. Level screed with flight screws (Figure 5-5,2) until neutral position is felt.

NOTE: Neutral position is when the pressure on the flight screw is the same when screwing either clockwise or counterclockwise.

5. Set the left or right SCREED LIFT lever to the FLOAT position. This will remove the hydraulic pressure from the cylinder, allowing screed to float.
6. Turn flight screw about one complete turn clockwise.

Setting Crown or Valley

NOTE: The screed plate is a one-piece unit that is flexed to provide the required crown setting.

1. Loosen lock down bolts (Figure 6-11,1,2) in slotted bars before adjusting crown and valley mechanism.
2. Remove crown handle and insert into adjuster (Figure 6-12,2).
3. For increased positive crown push down on adjuster.
4. For increased negative crown pull up on adjuster.
5. Use the gauge (Figure 6-12) located at the center of the screed above the standing platform. If the needle is above the zero, you will have positive crown. If the needle is below the zero, you will have negative crown.



Lock Down Bolts

Figure 6-11

- 1 - Cross Tube Bolt
- 2 - Center Link Bolt

6. To get exact crown or valley, measure the distance between a flat level surface to the center bottom portion of screed. Make adjustments with crown and valley control.

NOTE: Maximum crown is 2 in.

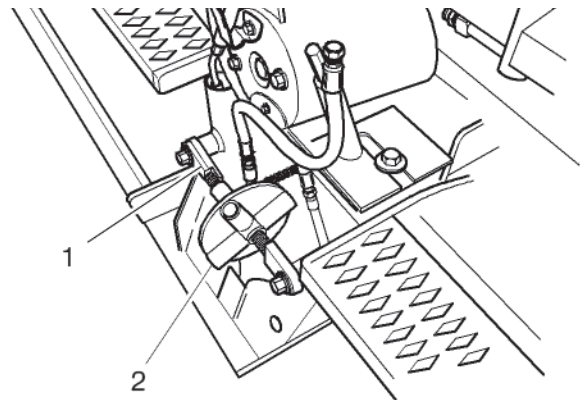

Crown Adjustment Location

Figure 6-12

- 1 - Hex Head Bolt
- 2 - Adjuster
- 3 - Gauge

NOTE: Positive crown is when the middle of the mat is raised to permit water to drain to each side. Negative crown is the lowering of the center of the screed plate. Negative crown might be used in an alley where drainage down the center of the alley is necessary (Figure 6-13).

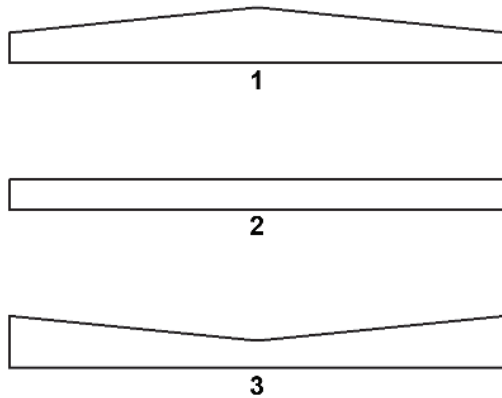

Crown Settings

Figure 6-13

1 - Positive (+)

2 - Zero (0)

3 - Negative (-)

NOTE: Crown may be placed in the leading edge and/or the trailing edge of the screed plate. Crown in the leading edge aids material flow under the screed plate only. Trailing edge crown puts a crown in the mat. As an example: trailing edge crown is 0, leading edge crown is 1/8 in. With this setup, there will not be any crown placed in the mat laid by the paver; however, material flow under the screed plate will be improved.

NOTE: Trailing edge crown is set at 0 when shipped from the factory. The chain connecting the leading and trailing edge crown control assures that the relationship of the edges remains constant as the trailing edge is changed to meet job conditions.

Setting Screed End Gates

1. On the first pass, turn the endgate depth screw (**Figure 6-14,1**) to lower the end gate until it is about 0.25 in. (6.35 mm) below the screed.

NOTE: Most operators run end gates within 0.25 in. (6.35 mm) of flush.

2. Turn the tilt screw (**Figure 6-14,2**) on the end gate so the front of the end gate tilts down slightly when the screed is lifted. This will allow the end gate to set itself to grade.

NOTE: When paving, never let the end gate carry the weight of the screed. This will cause screed compaction to vary.

3. During operation, if the end gate starts to dig in at front, adjust the tilt screw so the end gate tilts back.
4. When making a joint, the end gate must be set to where it fits flush with bottom of screed.

NOTE: Keep runners clean. When making a joint, spray cleaning solvent on runners (**Figure 6-14,4**).

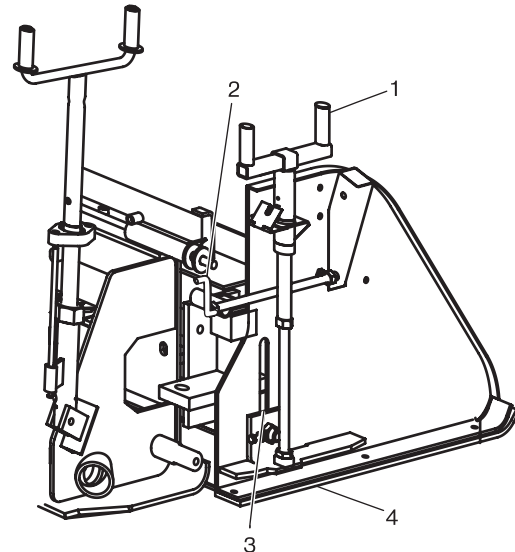

End Gates

Figure 6-14

1 - Endgate Depth Screw

2 - Tilt Screw

3 - Depth Gauge

4 - Runner

⚠ WARNING Fire Hazard! Never spray cleaning solvent or release agent on or near a screed heating element that is hot or being heated or on or near any open flame or ignition source. Cleaning solvent and release agent could ignite causing serious personal injury.

5. On the first pass, leave about 6 - 8 in. (15 - 20 cm) of unrolled asphalt where the joint is being made.
6. In laying a joint, if the joint looks too high or too low, adjust the flight screw (**Figure 6-14,2**) on the screed about one (1) turn at a time and allow 4 - 5 ft. (1.2 - 1.4 m) of travel to correct itself.

NOTE: Too much adjustment up or down may cause rising and falling effect in the paved material.

7. If making a cold joint, set end gate down about 1/4 in. (6.35 mm); this will give a nice, even edge.

Setting Screed Extensions

NOTE: Used when paving over 8 ft. (2.4 m).

The screed extensions should be heated with initial heating cycle before making adjustments. Use the wrench provided to make adjustments. If correct adjustment is made, the pressure on the rear edge of extended screed is the same as on the rear edge of main screed. The result of making this adjustment will be a smooth mat the length of the screed.

NOTE: Make adjustments only while paving.

1. Heat the screed extension before making adjustment to extended width.
2. Adjust tilt on the rear edge of the extension by turning adjustment (**Figure 6-15,1; Figure 6-16,2**) counterclockwise. This is done to give the same amount of compaction and slickness on the extension and main screed.
3. If drag occurs in center of the screed, then too much pressure is on the screed extension and the extension is carrying all the weight. Correct this by turning the adjustment clockwise until both the screed and the screed extension produce the same mat texture.

Mat Texture Adjustment

The screed should be hot before making any adjustments. The screed can be adjusted for a smoother or coarser mat texture by using the mat texture adjusting screws (**Figure 6-15; Figure 6-16**). Make sure the bottom of the screed is sprayed down before making any texture adjustments (see **Spray Down** in Section 6).

⚠ WARNING Fire Hazard! Never spray cleaning solvent or release agent on or near a screed heating element that is hot or being heated or on or near any open flame or ignition source. Cleaning solvent and release agent could ignite causing serious personal injury.

NOTE: When using spray down, consider the environment and do not allow cleaning solvent to run onto the ground.

Screed extension single adjustment:

1. Locate single adjuster near the middle of the extension (**Figure 6-15,1**).



Mat Texture Single Adjusters

Figure 6-15

1 - Extension Angle of Attack (AOA) Adjuster

2. Turning the AOA adjuster (**Figure 6-15,1**) clockwise (CW) will increase the pressure on the back of the screed. Turning the adjuster counterclockwise (CCW) will decrease the pressure on the back of the screed.

NOTE: Increasing the pressure on the back of the extension will give you a smoother, slicker finish. Decreasing the pressure will give you a coarser finish. Putting too much pressure on the back of the extension will take the weight off of the screed wearplate and will cause poor material compacting, resulting in a poor finish in the middle of the main screed.

Screed extension double adjustment:

NOTE: Double Adjuster extensions are optional.

1. There are two adjusters at each end of the extension (**Figure 6-16,1,2**). The adjuster farthest from the extension center is the vertical adjustment.

NOTE: Vertical Adjuster is preset by dealer and should not need adjustment.

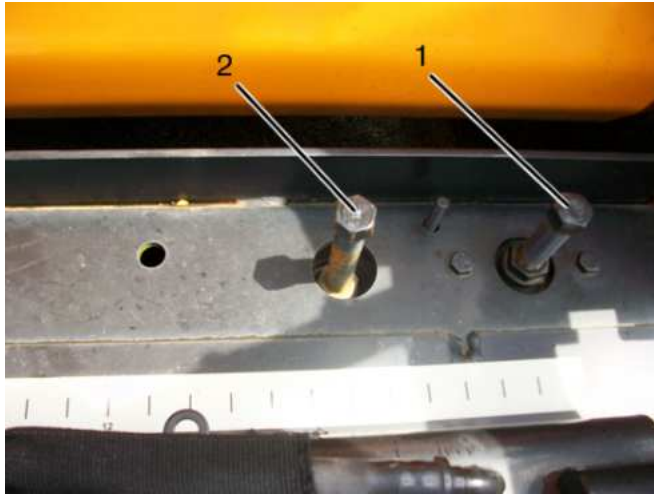

Mat Texture Double Adjusters

Figure 6-16

1 - Vertical Adjuster

2 - Extension Angle of Attack (AOA) Adjuster

2. Turning the AOA adjusters (**Figure 6-16,2**) clockwise will increase the pressure on the back of the extension. Turning the AOA adjusters counterclockwise will decrease the pressure on the back of the extension.

NOTE: Increasing the pressure on the back of the extension will give you a smoother, slicker finish. Decreasing the pressure will give you a coarser finish. Putting too much pressure on the back of the extension will take the weight off of the screed wearplate and will cause poor material compaction, resulting in a poor finish in the middle of the main screed.

UNLOADING AND LOADING

Trailers used to haul the paver should have ample capacity to carry the weight of the paver. Place the trailer in a clear, level area for loading or unloading.

CAUTION Work slowly and carefully to avoid accidents. Keep the area clear.

Unloading

1. Remove tie down equipment.
2. Start and warm up engine.
3. Set throttle at 1/2 operating RPM. Set steering control lever so paver moves very slowly.
4. Make sure:
 - a. Screed position - UP
 - b. Auger extensions removed
 - c. Extendible screed - IN
 - d. Gates below augers - CLOSED

NOTICE Never back up with cutoff gates open.

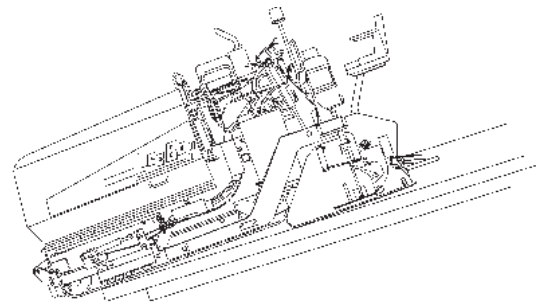

Correct Loading/Unloading Position

Figure 6-17

NOTE: A man should always be on the ground to assist the operator in the unloading procedure.

WARNING Make sure engine is operating at a high enough RPM so that the hydraulic pump is providing sufficient flow to operate all functions properly.

CAUTION Do not let the screed strike the ramp when moving off the ramp. This can break the bearings on the thickness control screws or welds on the leveling arms. A longer ramp or blocks may be necessary to reduce the loading angle.

NOTE: If you have a problem unloading the paver - STOP - LOOK - THINK.

5. Move paver forward down the ramp as shown (**Figure 6-17**).

Loading

CAUTION Paver must be loaded screed end first to prevent damage. If the paver is loaded hopper end first, the weight of the operator on the walkway will tend to tip the paver onto the screed (Figure 6-18).

1. Move paver to base of ramp. Line up tracks with the ramp.
2. Make sure of the following:
 - a. Screed position is - UP
 - b. Extendable screed - IN
 - c. Gates below auger - CLOSED

NOTICE Never back up with cutoff gates open.

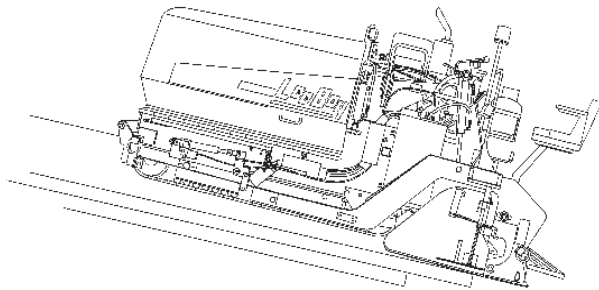

Incorrect Loading/Unloading Position

Figure 6-18

NOTE: Always have a helper on the ground that can assist the operator in moving the paver onto the transport.

CAUTION To prevent an excessive jolt to the undercarriage and throughout the paver, reduce traveling speeds to a minimum before the paver tracks come in contact with loading ramps or an abrupt change in the surface. If encountered, the track drive sprocket or possible other components may be damaged because of the excessive jolt.

3. Load paver screed end first. Set throttle at 1/2 operating RPM and steering control lever so paver moves very slowly onto the ramp.
4. With the steering control lever slowly guide the paver up the ramp.
5. Place paver in center of trailer or desired position.
6. Lower screed to deck.
7. Shut down engine.
8. Secure paver to transport as directed by regulations.

Tie Down Procedure

1. Position paver on trailer centered from side to side (Figure 6-19).

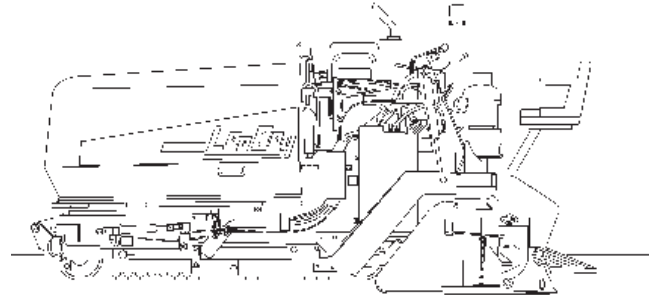

Paver On Transport

Figure 6-19

2. Attach tie down chains to the hopper end of paver at the D-rings.
3. Attach tie down chains to the screed end of paver at the D-rings (Figure 6-20).
4. Place chocks at wheels or tracks.
5. Make sure all chains are tight before moving.

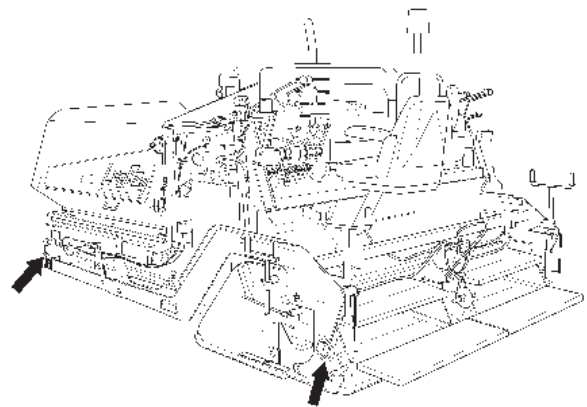

Tie Down Points

Figure 6-20

ELECTRIC SCREED HEATING SYSTEM (OPTION)

The following components are part of a LeeBoy Model 8500B Conveyor Paver equipped with optional electric screed heating system.

Generator

The fine tune speed adjustment (**Figure 6-21,1**) is on the top of the manifold. The two ports facing you in the picture are pressure (**Figure 6-21,2**) and the discharge port (**Figure 6-21,3**). The pressure line is on the right, going into the manifold, and the discharge line is on the left, coming out of the motor. The fitting (**Figure 6-21,4**) coming out of the top of the manifold is the motor case drain, and is tied directly to the lower hydraulic belly tank. The generator is provided oil for operation by a gear pump on the paver engine.

NOTICE Do not run heating elements and auxiliary operations, such as augers, at the same time for extended periods over 1/2 hour. Generator and heating element damage will occur.

NOTE: The faster the engine is run, the faster the generator will run also.

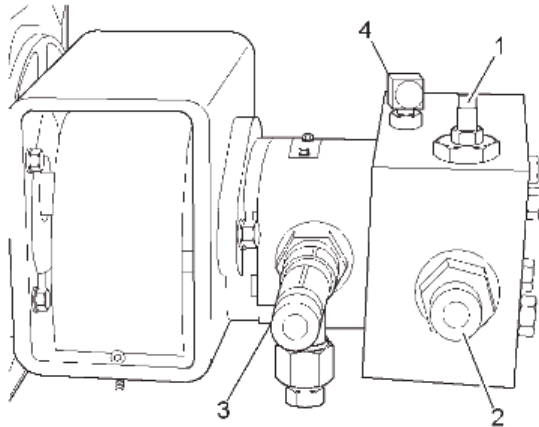

Generator Detail

Figure 6-21

- 1 - Fine Speed Adjust
- 2 - Pressure Port
- 3 - Discharge Port
- 4 - Motor Case Drain

The entire generator is shown in **Figure 6-22**. Note the electrical cord (**Figure 6-22,1**) coming out of the case of the generator at the far left. This is the cable that runs to the rear of your paver that supplies power to the screed. This cable should be inspected regularly to ensure that no damage has occurred to the cable during normal operation.

NOTE: If damage is seen in the power cable, the unit should not be operated until a new cable is installed.

Figure 6-22 also shows the location of the main output breaker (**Figure 6-22,2**) in your generator. All output power from the generator is lost when this breaker is in the “tripped” or “off” position.

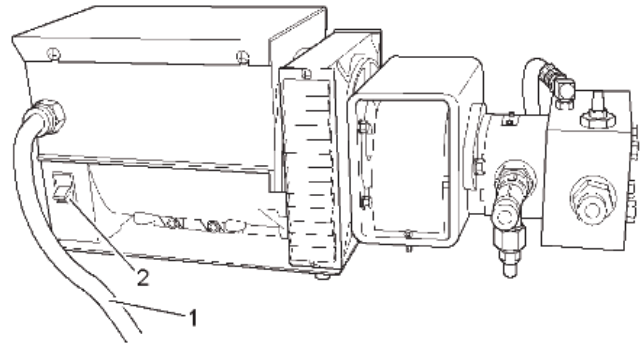

Generator

Figure 6-22

- 1 - Electrical Cord
- 2 - Main Output Breaker

NOTE: If, when your screed heat system is turned on, you have no heat on any screed, this breaker should be checked. If, after resetting the breaker, it will not stay in the ON position, a screed wiring fault should be assumed (see **Troubleshooting** in Section 8).

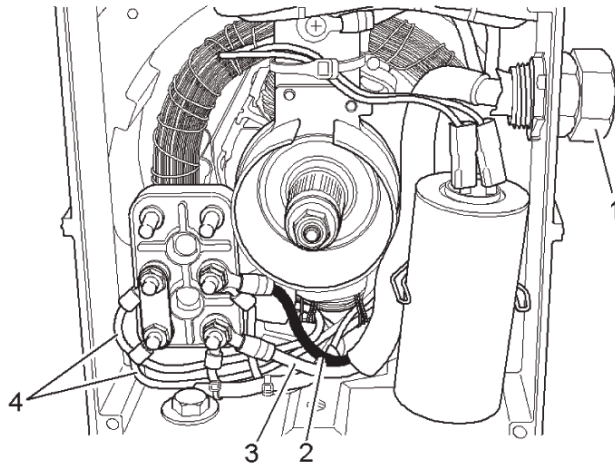

Generator Rear View

Figure 6-23

- 1 - Power Cable
- 2 - L1 (Black Wire)
- 3 - L2 (White Wire)
- 4 - Generator Winding Wire

The rear of the generator is shown in **Figure 6-23**. You can see the power cable (**Figure 6-23,1**) coming into the generator case at the top right. Just below the generator case is the voltage capacitor. The capacitor controls the output voltage of the generator, and may need to be changed if no voltage is generated by the set (see **Generator Voltage Testing** in Section 7).

The main output of the generator is located in the lower left of the picture. You will see two main wires attached to the generator, a black wire (**Figure 6-23,2**), and a white wire (**Figure 6-23,3**). The other two wires (**Figure 6-23,4**) are generator winding wires, and should not need to be serviced under normal circumstances.

Control Box

NOTE: All control boxes are manufactured the same to fit all screed and paver combinations. If your screed does not have enough element wires to fill all the plugs on the bottom of the control box, it may be normal. Any plugs that are not filled should be capped with appropriate plug terminator.

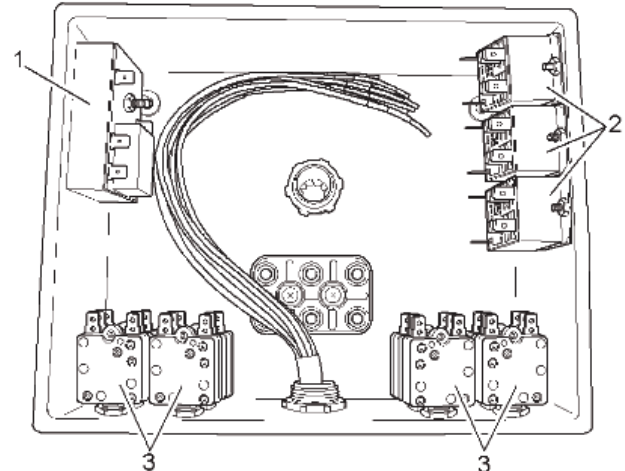

Electric Heat Control Box Before Wiring Completed

Figure 6-24

- 1 - System Timer
- 2 - Element Relays
- 3 - Element Breakers

The control box consists of three major types of components. The system timer (**Figure 6-24,1**) is located in the upper left hand corner of the box. The element relays (**Figure 6-24,2**) are located in the upper right hand corner of the box, and the element breakers (**Figure 6-24,3**) are located in the lower surface of the box. The other block in the center is used as a wire junction block only (see **Schematics** in Section 9).

Cycle Timer

A heat system timer is shown (Figure 6-25). There are six terminals on the timer. The top two left terminals are the main 12vdc input terminals for the timer. The ground (Figure 6-25,1) is on the left and the power (Figure 6-25,2) is on the right.

The top right terminal is the common terminal (Figure 6-25,3) to the internal timer relay that controls the heat system. When power is applied to the input terminal, it is also jumped to the common (or COM) terminal on the timer. The lower right two terminals on the timer are the outputs of the internal timer relay.

The left of these two is the normally closed terminal (Figure 6-25,4), which is not used in this system, and the lower right terminal (Figure 6-25,5) is the normally open terminal. The normally open terminal is used as the output terminal to “turn” the heating system on. The lower left hand terminal (Figure 6-25,6) is the “initiate” contact. When the HEAT ON button (Figure 6-8,2) is depressed, 12vdc is momentarily applied to this terminal to start the timer cycle. During the timer cycle, power will not be applied to this terminal unless the HEAT ON button (Figure 6-8,2) is depressed again. Keep in mind, if this happens, the timer will restart.

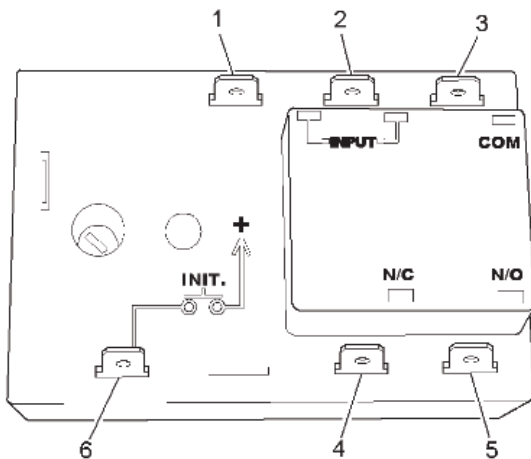

Heat System Timer Terminals

Figure 6-25

- 1 - Ground Input
- 2 - Power Input
- 3 - Common (COM)
- 4 - Terminal Output
- 5 - Terminal Output
- 6 - Initiate Terminal

Element Relay

Each element output from the bottom of the box consists of two wires. One wire will connect to the L1 circuit, and the other wire will connect to the L2 circuit. The L1 circuit is the left bank of element breakers. Each breaker has two terminals. One terminal is connected to the main input, and the other terminal is connected directly to an element output wire. The L2 circuit is the right bank of element breakers. This bank is wired slightly different, in that each leg not only goes from the main L2 power lead through a breaker, but each leg then goes through one of the six contacts on the element relays. It is these relays that “make” or “break” the circuit to each element to start or stop the heating cycles.

An element relay is shown here (Figure 6-26). There are three relays in the control box. Each relay has two separate sets of contacts operated by one coil.

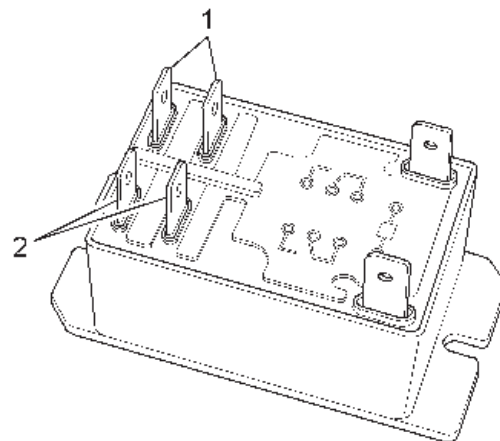

Element Relay

Figure 6-26

- 1 - Coil Terminals
- 2 - Contact Terminals

The coil contacts on the relay shown are at the top and bottom of the right hand side of the relay (Figure 6-26,1). One set of contacts are the two terminals at the top left of the relay, and the other set of contacts (Figure 6-26,2) are at the bottom left of the relay shown. When the coil is energized, both sets of contacts will close. All the relays used are “normally open” (see **Testing Element Relays** in Section 7).

Element Breaker

The breakers are wired into each leg of each element. If an element has a fault, either in the wiring, or in the element itself, the breaker will trip and power will no longer be applied to that leg of the element. The breakers can be manually reset by depressing the trip button back in when they are extended. If by depressing the breaker re-set, the breaker will not reset, there may be a need to replace the breaker, or diagnose the element, or element wiring, it is connected to.

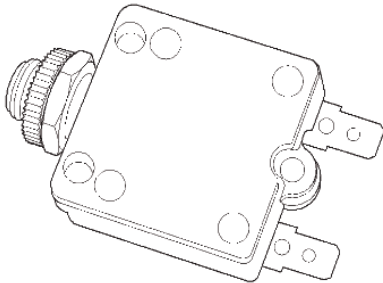

Element Breaker

Figure 6-27

Element Connections

The bottom of the control box contains the system element breakers, and the 6 main outputs for the screed heating elements (**Figure 6-28**). Since the heating elements are powered by 220VAC to 240VAC, each element has two breakers (**Figure 6-28,2**). There is one breaker for each leg of each element. Also shown is one of the two pin plugs that supplies power to the screed elements.

NOTE: Any element lead can be plugged into any supply plug (**Figure 6-28,1**) under the heating control/distribution box. All six plugs are equally rated.

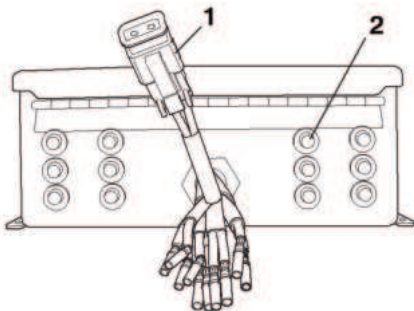

Electric Heat Control Box Bottom and Breakers

Figure 6-28

- 1 - Element Lead
- 2 - Breaker

Element Assembly

Next in the electric screed heating system are the screed heating elements themselves. Each element is sized to fit properly in your screed, and provide sufficient power to heat your screed plate to a temperature that mix will not drag or stick to the lower surface of the screed plate.

An element assembly consists of four main components. The element (**Figure 6-29,1**), the wire protector adapter (**Figure 6-29,2**), the wire protector (**Figure 6-29,3**), and the two pin wire plug (**Figure 6-29,4**) at the end of the element protector (**Figure 6-29,3**).

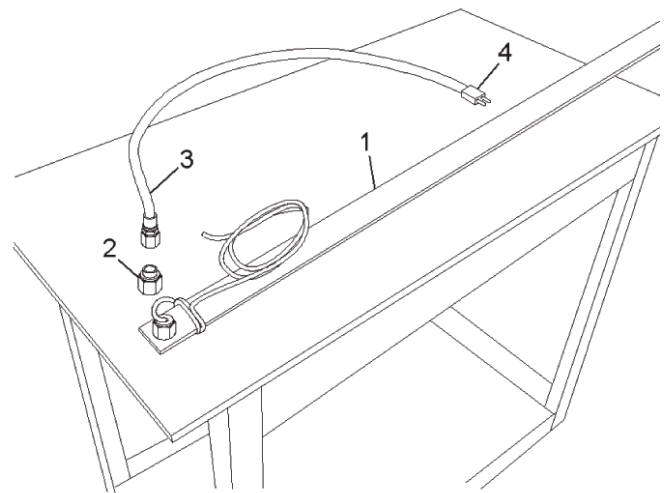

Heating Element Assembly

Figure 6-29

- 1 - Element
- 2 - Wire Protector Adapter
- 3 - Wire Protector
- 4 - Two Pin Plug

Each element (**Figure 6-30,1**) used has a thin strip of insulation (**Figure 6-30,2**) over it to keep the heat of the element from escaping. A support bar (**Figure 6-30,3**) is then laid over the element, and a shield (**Figure 6-30,4**) protects the element assembly. Each element is clamped down to the screed plate so as to provide a positive and efficient connection between the element and the screed plate.

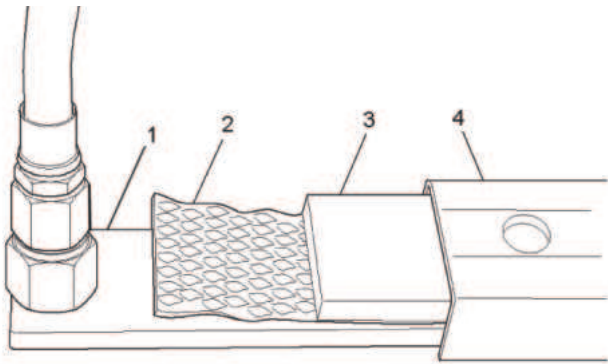

Heating Element Assembly Detail

Figure 6-30

- 1 - Element
- 2 - Insulation
- 3 - Support Bar
- 4 - Shield

A typical element clamp assembly is shown (**Figure 6-31**). The clamp setup may vary slightly depending on your screed size, or whether you are working on the extension or main screed plates. The principle is the same with all of the clamps.

Enough pressure should be applied to the element assembly to sufficiently hold the element tight against the screed plate surface. All clamp setups are lockable with a jam nut on the adjustment screw. After tightening the clamping stud, lock the clamp by tightening the stud jam nut. To remove an element, loosen all the clamping studs over the element, and then the element can be removed from the frame through the access provided at the outer end of the screed. The extension elements are accessed by removing the top cover from the extension screed plate.

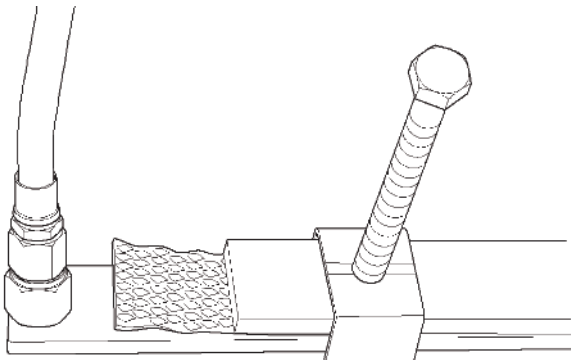

Typical Heating Element Clamp

Figure 6-31

TRUCK HITCH ATTACHMENT (OPTION)

The truck hitch is an optional attachment. It was designed to improve the asphalt laying process. This is mainly accomplished by keeping the truck driver off his brakes, preventing excessive and uneven braking. To engage the hitch with the rear wheels of the asphalt truck, proceed as follows:

NOTE: Manual Valve Lever on left side of paver must be in Truck Hitch Position (toward Operator Dash) to work the truck hitch.

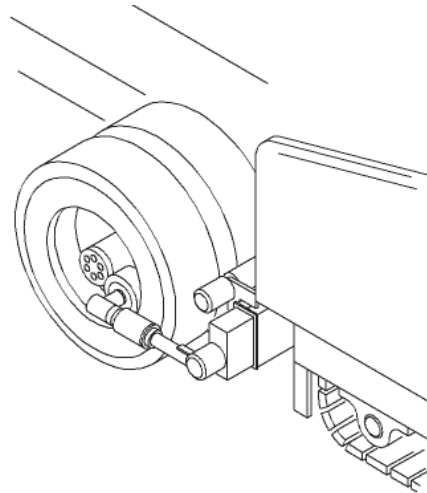

Truck Hitch Option

Figure 6-32

1. Extend the arm extensions of the truck hitch by setting the TRUCK HITCH IN/OUT Lever (**Figure 5-4,1**) to the OUT (Down) position to extend the hitch arms.
2. Slowly drive paver toward rear of truck until roll on hitch makes contact with the rear tires of the truck.
3. Retract the arm extension by setting the TRUCK HITCH IN/OUT Lever (**Figure 5-4,1**) to the IN (Up) position to retract the hitch arms until both guide rollers are fully locked into truck wheel rims.
4. It may be necessary to adjust the roller guides to the inside of the wheel rims, initially.

UMBRELLA (OPTION)

Assembly Instructions

1. Install Umbrella Mounting bracket (See bracket mounting instructions furnished with each bracket).
2. Insert ball stud (Figure 6-33,3) on curved shaft into umbrella support shaft (Figure 6-33,1), align holes, and drive 3/16" X 1" spiral spring pins (Figure 6-33,2) into position. Install locking handle (Figure 6-33,5).
3. Place canvas cover (Figure 6-33,7) over umbrella frame assembly (Figure 6-33,8) and hook corners to bows - tie each bow securely with tie straps.
4. Insert umbrella frame assembly (Figure 6-33,8) with canvas in place into tube on curved shaft (Figure 6-33,3) and insert bolt (Figure 6-33,6). Tighten snugly with nut (Figure 6-33,4).
5. Install complete umbrella into clamp on umbrella mounting bracket. Each bow may be raised individually until locked into open position (Figure 6-33,15). Each bow has two positions in which it can be locked open. This is to allow for arc stretch in canvas.

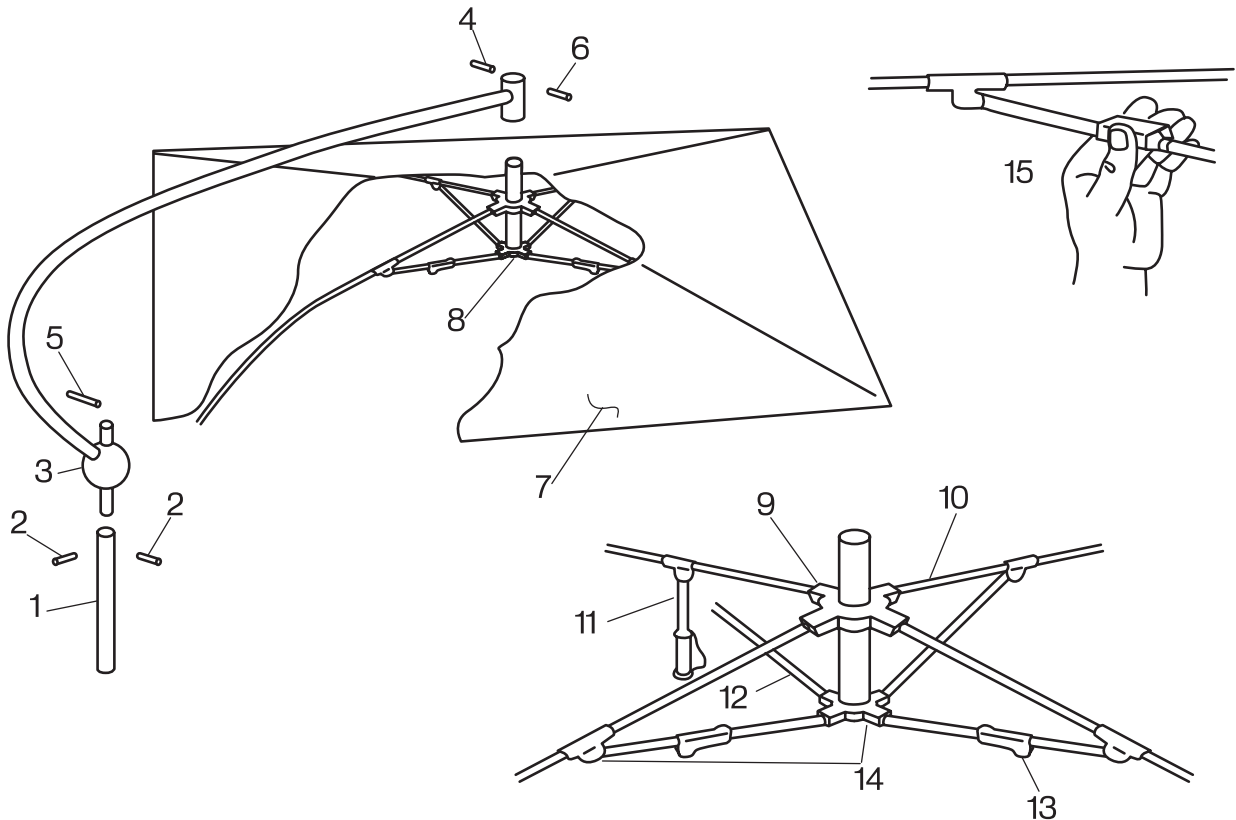

Umbrella Illustration

Figure 6-33

NOTES



Section 7 MAINTENANCE

	Page
Maintenance	7-1
Maintenance Schedule	7-5
General Information	7-5
Preparing Paver for Maintenance	7-6
Paver Lubrication	7-6
10-Hour or Daily Routine Maintenance	7-6
After The First 50 Hours and Weekly Routine Maintenance	7-7
100-Hour or Monthly Routine Maintenance	7-8
250-Hour or Quarterly Routine Maintenance	7-8
500-Hour or Semi-Annual Routine Maintenance	7-8
1000 Hour or Annual Routine Maintenance	7-8
Maintenance Adjustments	7-9
Raising Conveyor	7-9
Lowering Conveyor	7-10
Auger Drive Chain Adjustment	7-10
Conveyor Drive Chain Adjustment	7-11
Conveyor Flight Chain Adjustment	7-11
OVERRIDING HATZ FUEL SOLENOID VALVE	7-12
Torque Hub Hydraulic Motor Adjustment	7-13
Torque Hub Lubrication	7-13
Automatic Track Adjustment	7-13
Track Tension Pressure	7-14
Track Tension Release	7-14
Conveyor Limit Switch Adjustment	7-14
Screed Extension Top Guide Adjustment	7-15
Electrical System	7-16



Battery Servicing	7-16
Engine Maintenance	7-17
General Information	7-17
Engine Lubrication Oil	7-17
Changing The Engine Lubrication Oil Filter	7-18
Fuel system	7-19
Fuel Tank	7-19
Engine Fuel Filters	7-19
Engine Air Filter	7-20
Overriding Hatz Fuel Solenoid Valve	7-20
Hydraulic System	7-21
Checking The Hydraulic Oil Level	7-21
Changing The Hydraulic Oil	7-22
Changing The Hydraulic Oil Strainer	7-23
Removal & Installation Procedures	7-23
Track Components	7-23
Rubber Track Replacement	7-25
Torque Hub Replacement	7-26
Rear Conveyor Shaft Replacement.	7-27
Auger And Inner Bearing Replacement.	7-28
Screed Extensions, Slides Or Bushing Replacement.	7-29
Screed Wear Plate Replacement.	7-29
Extension Wear Plate Replacement	7-30
2-Speed Hydraulic Motor Replacement	7-30
Tandem Servo Pump Replacement	7-31
Safety Label Installation	7-32

Table 7-1. Periodic Maintenance Schedule

SYSTEM	ITEM	10 Hours Daily	50 Hours Weekly	100 Hours Monthly	250 Hours Quarterly	500 Hours Semi-Annually	1000 Hours Annually
Paver	Lubricate paver (Figure 7-1; Figure 7-2; Table 7-2)	X	X				
Hydraulic	Check oil level		X				
	Torque hub oil level			X			
	Replace oil charge filter cartridge				X		
	Replace oil				X		
	Replace oil suction filter				X		
	Replace strainer filter				X		
	Replace drive torque hub oil					X	
Engine	Inspect belts, replace A/R				X		
	Inspect air intake hoses and clamps				X		
	Inspect alternator and connections						X
	Check valve clearance						X
Electrical	Check all wiring connections		X				
	Service battery						X
Engine Oil and Filter	Replace conveyor torque hub oil					X	X
	Replace engine oil and oil filter cartridge					X	
	Check oil level - change at initial 50 hours	X					
Engine Air Cleaner	Check/clean air cleaner element				X		
	Replace air cleaner element					X	
	Check air cleaner indicator	X					
Fuel	Drain contaminant water/deposits from water separator	X					
	Replace fuel filter cartridge					X	
	Inspect Fuel System Hoses and Clamps		X				
Cooling	Clean engine cooling system					X	
	Coolant Level, check and change A/R	X					
	Inspect Coolant Hoses and Clamps				X		
	Clean radiator				X		
Mechanical	Adjust conveyor drive chains			X			
	Adjust conveyor flight chains			X			
	Adjust auger chains			X			
	Screed extension top guide adjustment			X			

LUBRICATION CHART

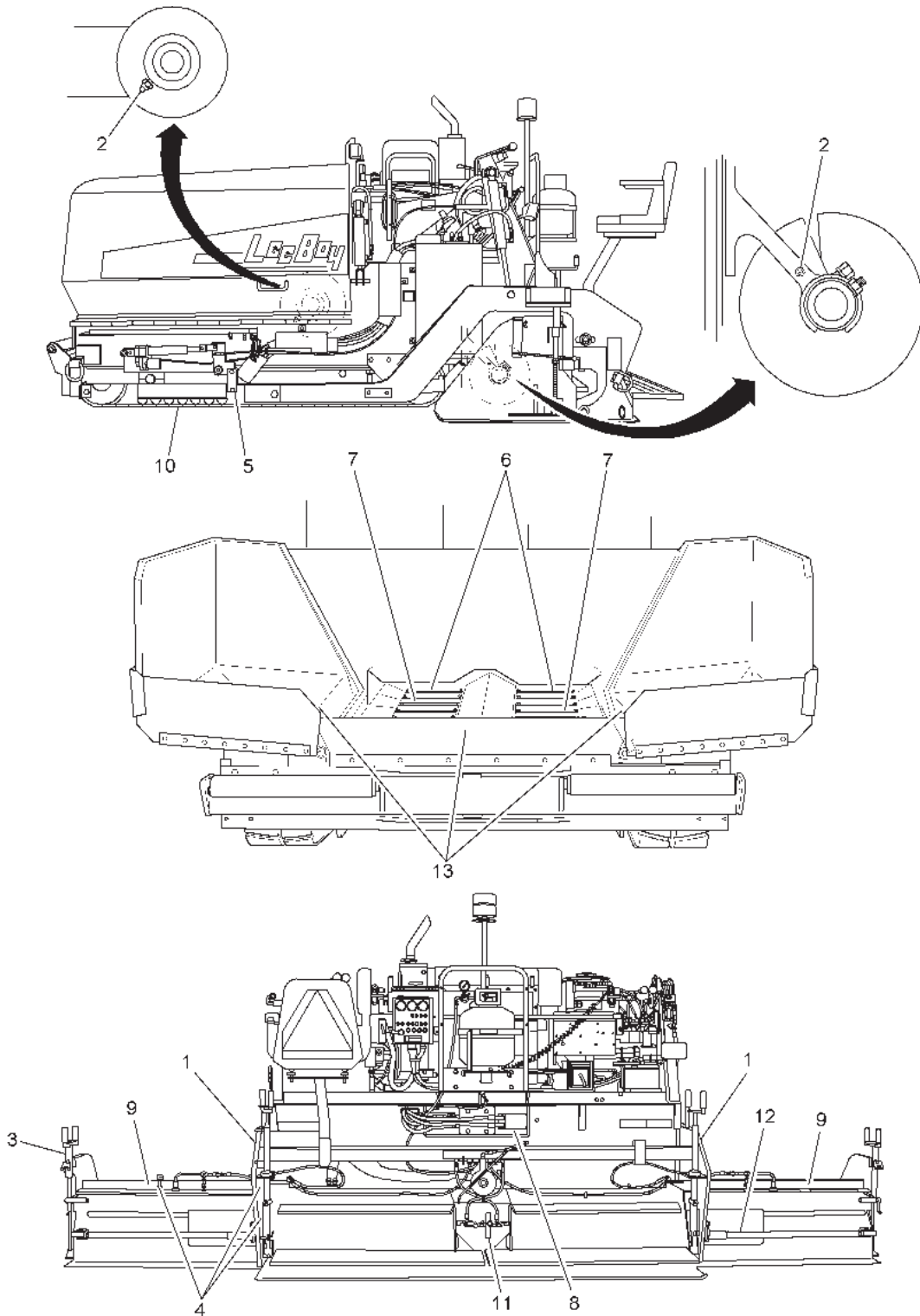

Lubrication Points

Figure 7-1

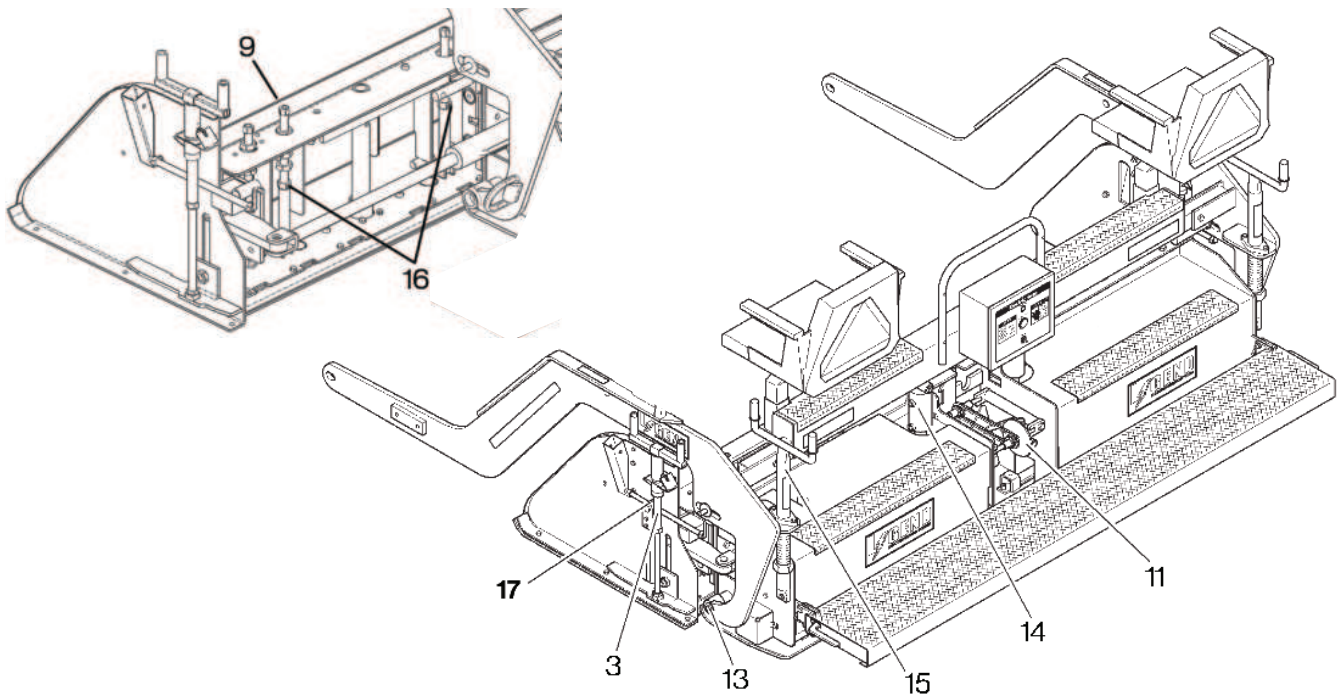

Lubrication Points

Figure 7-2

Table 7-2. Lubrication Points Schedule

ITEM NO.	TYPE LUB	DESCRIPTION AND LOCATION	INTERVAL
Legend	A	Grease With Shell Avania EP Grease 2 Or Equivalent	
	B	Spray With An Approved Release Agent	
1	A	Auger, grease fitting on end mount (end of day)	Daily
2	A	Conveyor Pivot, front of screed each side under conveyor deck	Weekly
3	A	Depth Screw (grease first in lock position, unlock and turn 180° and grease)	Weekly
4	A	Flange Bearing and Fitting, on flight screw plus flange bearing, on T-handle of extension, (both sides)	Weekly
5	A	Pillar Block bearing, on rear axle	3 Months
6	A	Conveyor Chain, left and right side	Daily
7	B	Conveyor and Auger, as shown	Daily
8	B	Auger Chain, middle of paver	Daily
9	B	Paver, clean all surfaces	Daily
10	B	Tracks, between track pads	Daily
11	B	Screed Crown, on chain	Weekly
12	B	Spray any part of paver that contacts asphalt	Daily
13	A	Screed Pivot	Weekly
14	A	Slope Cylinder Pivot	Weekly
15	A	Main Flight Screws Ball Socket & Nut	Weekly
16	A	All Screws On Extension And Bearing	Weekly
17	A	Tilt Screws	Weekly

7

GENERAL INFORMATION

Before performing any maintenance procedures on the LeeBoy Model 8500B Conveyor Paver, read the following safety information and review **Safety** in Section 2.

⚠ WARNING **Tool Hazard! ALWAYS use tools appropriate for the task at hand and use the correct size tool for loosening or tightening screed parts.**

⚠ WARNING **Burn Hazard! ALWAYS handle hot components with heat-resistant gloves.**

This section gives the necessary procedures for routine and general maintenance on the LeeBoy Model 8500B Conveyor Paver. Follow all the Maintenance Schedules and Maintenance Procedures to maintain the machine in top operating order.

MAINTENANCE SCHEDULE

General Information

The Maintenance Schedule lists the recommended time intervals between LeeBoy Model 8500B Conveyor Paver maintenance inspections and lubrication procedures.

Table 7-1. Periodic Maintenance Schedule gives inspection and lubrication information for the LeeBoy Model 8500B Conveyor Paver.

The “Hour” and “Periodic” time periods list most service intervals. The maintenance schedule begins with 10-hour, or daily, maintenance intervals and continues through the 1000-hour, or annual, maintenance schedule intervals.

Preventive maintenance on the paver will provide years of trouble-free operation. Adjustment can be performed in the field with ordinary hand tools. Engine preventive maintenance, other than oil, air and fuel filter changes, is not covered in this section. Refer to current engine operator’s manual for engine service information.

NOTE: For your convenience there is an oil drain hose located inside of the right-hand side of paver.

NOTICE **The changing of oil and cleaning of the LeeBoy Model 8500B Conveyor Paver should only be done in a designated area that can contain the oil and chemicals involved in any maintenance requirement. These by-products should be discarded in accordance with environmental regulations.**

NOTICE **Do not substitute fasteners of any kind unless the fasteners are equal in size and grade as original equipment.**

NOTE: When performing any routine maintenance such as 50, 100, 250, 500 and 1000 hours, always include previous routine maintenance hours in the higher hourly schedule.

NOTE: If the paver is operated more than 10 hours per day, follow the “Hour” schedule. If the paver is operated less than 10 hours per day, follow the “Periodic” schedules, where they apply.

⚠ WARNING **Fire Hazard! Never spray cleaning solvent or release agent on or near a screed heating element that is hot or being heated or on or near any open flame or ignition source. Cleaning solvent and release agent could ignite causing serious personal injury.**

NOTICE **If mix is allowed to remain on the screed overnight, possible damage can result on start-up the next day. Poor housekeeping will increase maintenance costs.**

Preparing Paver for Maintenance

When performing maintenance, perform the following steps before leaving the operator’s position, unless the maintenance procedure instructs otherwise.

1. Park the paver on a flat even surface.
2. Lower all attachments to ground level.
3. Place transmission in neutral.
4. Run engine at 1/2 speed (RPM) without load for 3 to 5 minutes.
5. Reduce engine speed (RPM) to slow idle.
6. Place ignition switch in the OFF position.

⚠ WARNING **If maintenance must be performed with engine running, do not leave paver unattended.**

Paver Lubrication

Proper lubrication is necessary to maintain the LeeBoy Model 8500B Conveyor Paver at top efficiency. Refer to the lubrication information in **Table 7-2**. All lubrication points are shown in **Figure 7-1; Figure 7-2**.

10-Hour or Daily Routine Maintenance

1. Scrape off mix and spray cleaning solvent or release agent on the LeeBoy Model 8500B Conveyor Paver wearplate, extensions, and any place that has come in contact with the mix. All cleaning should be performed while the paver is hot.

WARNING Fire Hazard! Never spray cleaning solvent or release agent on or near a screed heating element that is hot or being heated or on or near any open flame or ignition source. Cleaning solvent and release agent could ignite causing serious personal injury.

NOTICE If mix is allowed to remain on the screed overnight, possible damage can result on start-up the next day. Poor housekeeping will increase maintenance costs.

2. Remove any debris from screed and check for leaks.

WARNING Pierce Hazard! Avoid skin contact with high-pressure hydraulic fluid spray caused by a hydraulic system leak such as a broken hydraulic hose line. High-pressure hydraulic fluid can penetrate your skin and result in serious injury. If you are exposed to high-pressure hydraulic fluid spray, obtain prompt medical treatment. Have your authorized LeeBoy Dealer repair the damage.

3. Tighten fittings as necessary. Replace hoses and fittings as needed.
4. Raise Conveyors (see *Raising Conveyor* in Section 7) and clean mix off all flat surfaces. This operation is quick and simple when the paver is still hot. Immediately after raising conveyors place the safety prop in proper position.

WARNING Use extreme care when working under conveyors. Clear the area of untrained personnel. Be sure safety prop is properly placed into support position (Figure 7-8).

NOTE: In cold weather, keep conveyor flight chains properly oiled with cleaning solvent or release agent. This will prevent conveyor bars from sticking. Neglect could result in conveyor bar damage or drive chain failure.

NOTICE If mix is allowed to remain in the paver overnight, possible damage can result upon start-up the next day. Poor housekeeping will increase maintenance costs.

5. Keep the fuel tank full to keep condensation from forming. Fill at end of day.
6. Perform engine preventive maintenance as described in your engine operator's manual. Any engine preventive maintenance should always begin with an oil check.
7. Lubricate paver according to *Lubrication Chart* in Section 7 (Table 7-2 and Figure 7-1; Figure 7-2).
8. Check for damaged, or loose element wires and harness connections. Repair or replace as required.
9. Check for damaged, loose, or missing decals. Replace decals as required (see *Safety Label Installation* in Section 7).

50-Hour (Initial) or Weekly Routine Maintenance

1. Check hydraulic oil and add if necessary.
2. To fill, remove top of return filter, located on top of reservoir, and pour through. If you have a hydraulic or air pump, you can fill at charge filter. (Remove cap and fill.)

NOTICE The LeeBoy Model 8500B Conveyor Paver hydraulic system requires clean, contaminant-free oil (see *Lubricant Specifications* in Section 4). Take care when working with the hydraulic system to ensure it is completely clean.

3. Adjust conveyor chains (see *Conveyor Drive Chain Adjustment* in Section 7).
4. Check auger chains, lubricate and adjust.

WARNING Fire and Explosion Hazard! Do not smoke when observing battery electrolyte level. The fumes can explode.

WARNING Burn Hazard! Electrolyte is an acid that can burn if it contacts skin or eyes. If contact is made, flush area immediately with water and obtain prompt medical attention.

5. Check all battery connections and remove any corrosion that is present. (Check cables daily.)
6. For both sides of the screed, lubricate all grease fittings on the flight screw, the fitting on the depth screw, and the fittings on the flange bearings located on top of the extension screed (Figure 7-1; Figure 7-2). Grease nuts on extension screws.
7. Blow dust from generator unit under hopper conveyor.

7

100-Hour or Monthly Routine Maintenance

1. Position the torque hub so the center plug (**Figure 7-3,1**) is at the twelve o'clock position. Remove the plug either at the three or nine o'clock position (**Figure 7-3,2**). If oil comes out, no oil is needed. Insert plug and tighten. If oil does not come out, remove the plug at the 12 o'clock position and fill torque hub with specified gear oil (see **Specifications** in Section 4) until oil starts to appear at the other hole. Replace both plugs and repeat process on other torque hub.

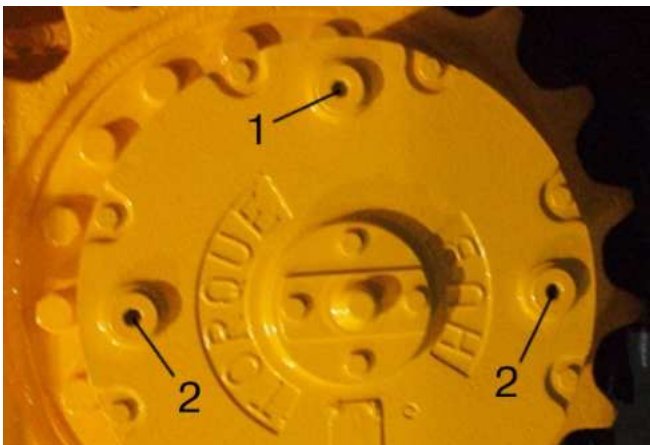

Torque Hub Plug Orientation

Figure 7-3

1 - Center Plug

2 - Side Plugs

2. Perform any other engine preventive maintenance as described in the engine operator's manual.
3. Check and adjust all chains, as required (see **Conveyor Drive Chain Adjustment** in Section 7).

250-Hour or Quarterly Routine Maintenance

1. Perform the 250-hour preventive maintenance as described in the engine operator's manual.
2. Change charge filter between valve bank and main pump.
3. Change return filter on hydraulic tank.
4. Check air cleaner, if the engine is equipped with a dry type element.

NOTICE Improperly serviced air cleaners quickly wear out engines and piston rings.

500-Hour or Semi-Annual Routine Maintenance

1. All bearings are sealed and have grease fittings. These should be greased with multipurpose grease using a hand grease gun. Be careful to avoid blowing the seals.
2. Perform the 500-hour preventive maintenance as described in the engine operator's manual.
3. Replace dry type air filter, if equipped. Refer to the current engine operator's manual for service information.
4. Change engine oil. To assure complete removal of contaminants in the oil, perform the oil change while engine is warm.
5. After draining used oil, clean and reinstall drain plug and fill crankcase to the full mark with manufacturer's recommended oil (see **Specifications** in Section 4).
6. Change engine oil and filters. Use the drain hose and fitting stored in the toolbox to drain engine oil.
7. Change oil in drive torque hubs, (see **Specifications** in Section 4).

1000-Hour or Annual Routine Maintenance

1. Drain and flush the hydraulic tank. A drain plug is located on the bottom of the tank for this purpose. Fill as required (see **Changing Hydraulic Oil** in Section 7).
2. Perform the 1000-hour preventive maintenance as described in the engine operator's manual.
3. Change oil in drive torque hubs, (see **Specifications** in Section 4).

MAINTENANCE ADJUSTMENTS

Extension Top Guide Adjustment

1. Close the left and right extensions to their fully retracted positions.
2. Loosen top jack bar bolts.
3. Use allen set screws on top of rail to tighten the upper slide guide rail down. Access the upper slide guide rails through the small openings in the upper cover near the front of the main screed frame. Start at the outside of the paver, and work to the center.
4. Retighten top slide rail bolts.
5. Check for binding - do not overtighten set screws.
6. Run the extensions out fully and grease the slide track rails.

NOTE: The slide tracks should be greased daily to help prevent excessive wear.

Replacing Screed Extension Wear Plates

Removal

1. Run extension out fully.
2. Remove endgate by disconnecting tilt screw and loosen the 7/8" jam nut.
3. Remove nut. Endgate will drop forward out of slot and slide off of stud.
4. Locate and unplug the element power wire. Make certain the wire running into the extension screed is loose and will drop away when the screed plate is removed with interference.
5. Remove shoulder bolts out of lower adjustment screws on top of wear plate (**Figure 7-4,1**).
6. Closely inspect all plugs, pins, and wires for damage. Replace if needed.
7. Lower screed to ground and pull front pivot pin out on 8500B (**Figure 7-5**).
8. Lift screed and wear plate should be disconnected.

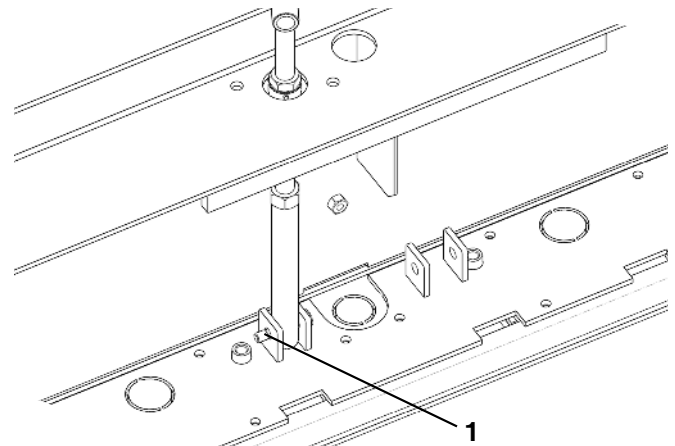

Wear Plate Shoulder Bolts

Figure 7-4

1 - Adjuster Screw Shoulder Bolt

Installation

1. Clean all areas where new wear plate will be attached.
2. Place new wear plate in position with floor jack or by lowering screed to floor and slide pivot pin in.
3. Reconnect the element power wire and re-tie the power cable to the attachment point provided.

NOTE: Do not tie the power cable so that it is tight. A small amount of slack in the cable where it enters the protective hose fitting is required.

4. Attach adjustment screws to new wear plate.
5. Place endgate back on.
6. Adjust 7/8" nut so that endgate will move up and down freely, then lock in place with jam nut.
7. Connect tilt screw.

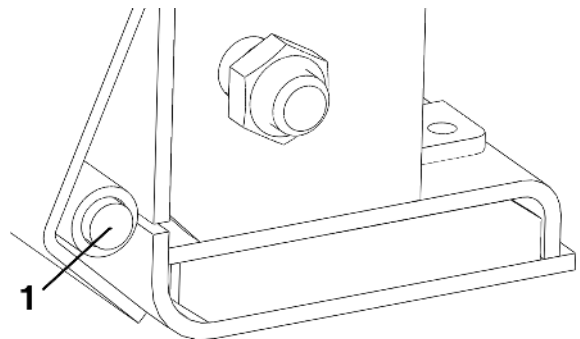

8500B Pivot Pin

Figure 7-5

1 - Extension Wear Plate Pivot Pin



Replacing Screed Main Wear Plates

Removal

1. Remove walk boards.
2. Remove screed lids.

NOTE: Once walk boards are removed lids will slide out.

3. Remove the twenty-four (24) bolts (**Figure 7-6,1**) holding wear plate to screed frame.

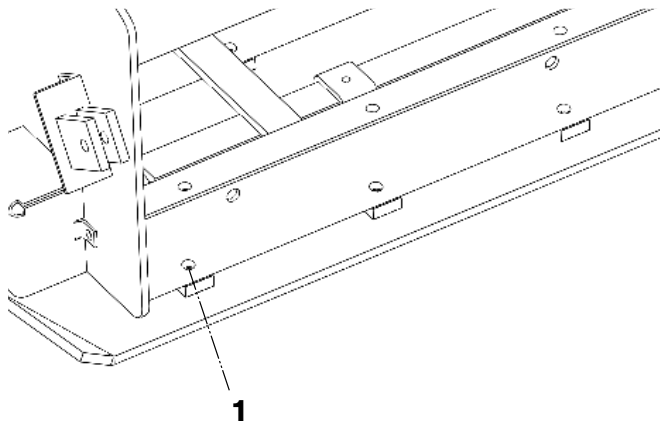

Wear Plate Mounting Bolts

Figure 7-6

1 - Bolt Location

4. Under the heating control/distribution box, locate the element attachment plugs. Remove the protective cover, and unplug the main screed elements so that the main element power wires can be lowered with the wear plate.
5. Closely inspect all plugs, pins, and wires for damage. Replace if needed.
6. Before raising screed off of wear plate, clamp center of crown gussets so that screed frame stays flat.
7. Raise screed off of wear plate.

Installation

1. Clean screed frame.
2. Set screed frame down on to new wear plate letting cylinders carry most of weight. This will allow wear plate to be moved to align with bolts.
3. Place five (5) bolts in front left side first, then right side.

NOTE: You may need to clamp or pry around or rotate crown in and out so that five (5) bolts in right side line up.

4. Once these bolts are in place, bolt rear of wear plate up to frame assembly.
5. Once bolts are started, lift screed and set on three 2" x 4" boards to hold flat. Place one board at each end and one in the center.
6. Level the screed with the flight screws (**Figure 5-5,2**) until neutral position is felt.

NOTE: Neutral position is when the pressure on the flight screw is the same when screwing either clockwise or counterclockwise.

7. Let screed all the way down and torque bolts from center out, 2 on left side then 2 on right side to 50 ft lbs. (67 N•m).
8. Install screed lids and walk boards.
9. Reconnect all element wires that were unplugged.

Raising Conveyor

CAUTION Before raising or lowering conveyors, fold side wings into the full “out” position.

1. Fold side wings all the way in, then remove bolts on side wings.
2. Grab top of wings and pull out 5 to 6 in. (13 to 15 cm), then pull bottom handle out till wing knuckles out (**Figure 7-7**).

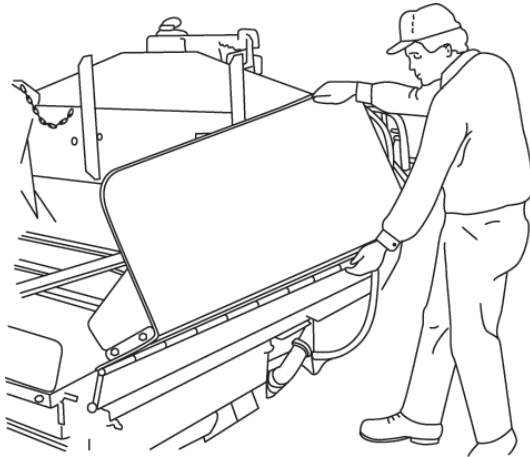

Side Wings

Figure 7-7

WARNING Crush Hazard! Safety prop must be placed in position. Use extreme care when working under conveyors. Clear the area of untrained personnel.

NOTE: Engine must be running to raise conveyor.

NOTE: Manual Valve Lever (**Figure 6-34**) on left side of paver must be in Conveyor Raise/Lower position (toward hopper) to work the CONVEYOR RAISE/LOWER switch.

3. Raise conveyor by pushing the CONVEYOR RAISE/LOWER handle upward to the RAISE position and hold until conveyor is fully raised.
4. Immediately after raising the hopper, place the safety prop in position (**Figure 7-8,1**).

NOTE: Engine should be turned off when lowering.

5. With engine turned OFF and Key ON, lower the conveyor onto the safety prop by pulling the CONVEYOR RAISE/LOWER handle downward to the LOWER position and hold until conveyor is fully lowered and is resting securely on the safety prop. This will provide a margin of safety preventing the safety prop from accidentally being dislodged.

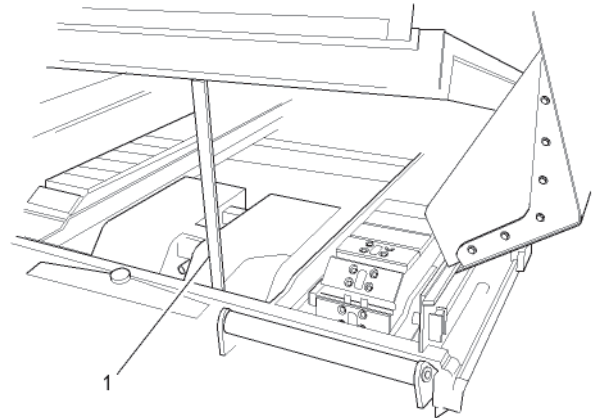

Safety Prop in Position

Figure 7-8

1 - Safety Prop

Lowering Conveyor

CAUTION Remove all tools or foreign objects before lowering.

1. Before lowering the conveyor, make sure that the area under the conveyor is clear of tools or foreign objects.
2. Release safety prop (**Figure 7-8,1**) carefully. If conveyor has dropped firmly down onto safety prop, it will be necessary to raise the conveyor. After raising the conveyor, lower the safety prop as instructed.
3. Lower the conveyor by pulling the CONVEYOR RAISE/LOWER handle downward to the LOWER position and hold until conveyor is fully lowered.
4. Clean area where side wings fold down.
5. Fold side wings back with same in and out knuckle motion used to raise the side wings.
6. Reinstall the hold down bolts on each side wing.

CAUTION Never pave with hold down bolts out. Side wings may lift, letting asphalt get into conveyor chains.

7

Conveyor Flight Chain Adjustment

NOTICE For cold weather, keep conveyor flight chain properly oiled with cleaning solvent or release agent. This will prevent conveyor from sticking inside of conveyor pan. Neglect could result in conveyor bars bowing if conveyor sticks.

NOTE: The conveyor should run smooth when conveyor chain is properly adjusted. These chains should be adjusted every 100 hours to maintain smooth operations. If irregular movement of the conveyor occurs, this is generally a sign that an adjustment is needed.

Use the following procedure to make adjustment:

1. Raise conveyors (see **Raising Conveyor** in Section 7). Put keys in safe place.
2. Secure safety prop (**Figure 7-8,1**) to prevent conveyor from accidentally lowering.
3. Loosen the locknut (**Figure 7-9,1**) and bolt holding the Adjustment Roller Assembly.
4. Turn adjustment bolts (**Figure 7-9,2**) alternately on both sides of the conveyor. (LeeBoy recommends turning one bolt one half turn, then the other bolt one half turn. Continue alternating tightening until chains are tight). The pressure on the chain will be noticeable as the bolts are tightened.
5. After the conveyor chain tension is set, tighten locknut (**Figure 7-9,1**) and bolt holding assembly.
6. If the adjustment bolts (**Figure 7-9,2**) have been run out, it will be necessary to remove a link in the conveyor chains and add a half link. This repair should bring the adjustment bolts back to full travel.
7. Repeat steps 1 through 4 for the opposite side.

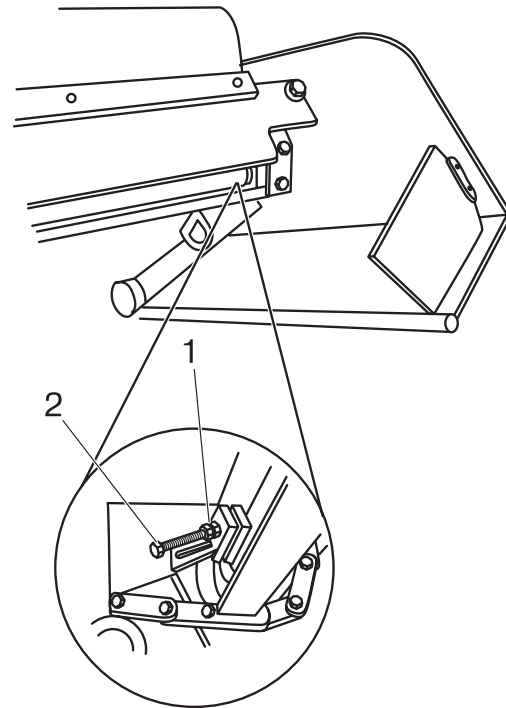

Adjusting Bolt

Figure 7-9

1 - Locknut

2 - Adjustment Bolt

Automatic Track Adjustment

NOTE: Failure to maintain adequate throttle setting may cause improper adjustment to track.

CAUTION When backing this paver with load, maintain at least a three-quarter throttle setting. Failure to do so may cause improper track tension, resulting in poor performance and damage.

Hydraulic adjustment cylinders are automatic and provide even tension on track that prevents excessive wear to paver undercarriage. This feature requires the operator, when backing with load, to maintain at least three-quarter throttle setting. Hydraulic pressure below three-quarter throttle is not adequate to maintain track adjustment.

Conveyor Drive Chain Adjustment

CAUTION Entanglement Hazard! Do not run engine while checking and servicing conveyor drive train.

1. Look at drive chain through the top of the frame. If drive chain has excessive loose motion in it, adjustment is necessary.

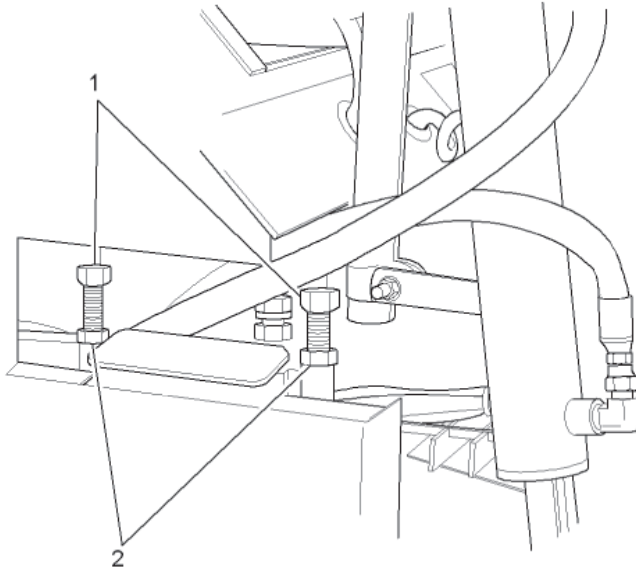

Conveyor Chain Adjusting Bolts

Figure 7-10

1 - Chain Adjuster

2 - Locknut

2. If adjustment is necessary, continue to operate conveyors at fast speed and loosen the locknuts (**Figure 7-10,2**) on the chain adjuster. Turn the chain adjuster (**Figure 7-10,1**) until the whip in the drive chain disappears.
3. Retighten locknuts (**Figure 7-10,2**) when adjustment is made.
4. Perform the same check on the opposite conveyor drive chain.

Torque Hub Hydraulic Motor Adjustment

Low Gear

NOTE: Torque hub hydraulic motors are calibrated and set at the factory. Only an Authorized LeeBoy Dealer should make adjustments.

NOTE: The low gear adjustment screw is located on bottom of drive motor.

The adjustment must be made to the slow side drive motor only. Only make small changes at a time and recheck paver. Proceed as follows:

NOTE: Low gear operation requires the 2-SPEED HIGH/LOW switches on both sides of the dash panel to be in the LOW position.

1. With paver running, set both 2-SPEED HIGH/LOW switches to the LOW position. Red 2-SPEED LIGHT should not be illuminated.
2. Locate adjustment screw on the bottom of the hydraulic motor.
3. Adjust screw in small increments of about 1/4 turn then recheck tracking.

High Gear

NOTE: The high gear adjustment screw is located on top of drive motor.

Tracking adjustment on the high side gear is performed by adjusting the screw on top of hydraulic motor. The adjustment on the motor for the fast track must be screwed in to equalize track speed.

NOTE: If hydraulic motor has not been previously set, ten revolutions of the adjustment screw may be required before noticing any difference in travel.

NOTE: High gear operation requires the 2-SPEED HIGH/LOW switch on either side of the dash panel to be in the HIGH position.

1. With paver running, set either 2-SPEED HIGH/LOW switch to the HIGH position. Red 2-SPEED LIGHT will be illuminated.
2. Adjust screw on top of hydraulic motor until back pressure from spool is felt on adjustment screw. This indicates adjustment is close.
3. Finalize adjustment by making one quarter (1/4) turn at a time until correct adjustment is made.

7

Auger Drive Chain Adjustment

1. The auger chains should be just snug, not loose. To tighten chains, loosen bolts (**Figure 7-11,1,2**) in slots provided for take up.
2. To adjust chains for the right auger, use bolts (**Figure 7-11,1**). For left auger adjustment use bolts (**Figure 7-11,2**).
3. Tighten adjustment bolts to a torque of 209 ft. lbs. (283 N•m).

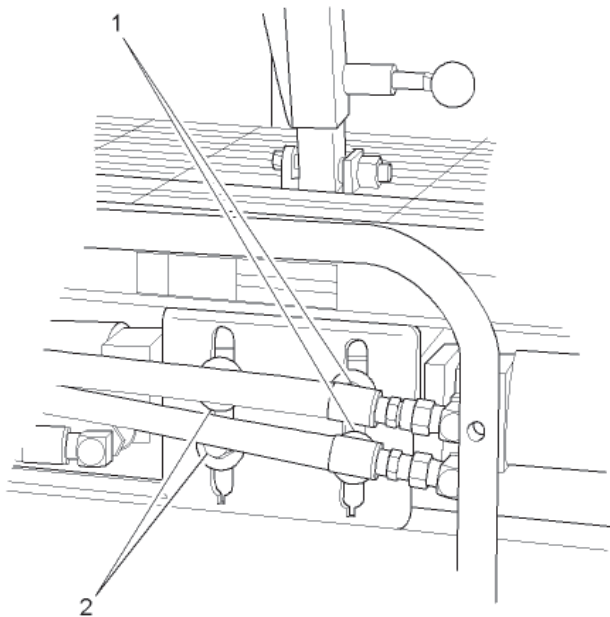

Auger Chain Adjusting Bolts

Figure 7-11

1 - Right Auger Chain Adjuster Bolts

2 - Left Auger Chain Adjuster Bolts

Torque Hub Lubrication

NOTE: See **100-Hour or Monthly Routine Maintenance** in Section 7.

1. Position the torque hub so the center plug (**Figure 7-3,1**) is at the twelve o'clock position. Remove the plug either at the three or nine o'clock position (**Figure 7-3,2**). If oil comes out, no oil is needed. Insert plug and tighten.
2. If oil does not come out, remove the plug at the 12 o'clock position and fill torque hub with specified gear oil (see **Specifications** in Section 4) until oil starts to appear at the other hole.
3. Replace both plugs and repeat process on other torque hub.

Track Tension Pressure Relief

Pressure Check

NOTE: Relief pressure is set at 700 PSI at track tension manifold (**Figure 10-1,43**).

1. To check pressure, connect a 2000 PSI. gauge at one of the hoses going to the track tension cylinder (**Figure 10-1,19**).
2. Place a hydraulic jack between front idler (**Figure 10-1,14**) and track rail.
3. Back paver up slowly and observe gauge. Pressure should go to 700 PSI. If pressure is not correct, adjust relief IN for more pressure and OUT for less pressure.
4. Place a hydraulic jack between front idler (**Figure 10-1,14**) and track rail.
5. Back paver up slowly and observe gauge. Pressure should go to 700 PSI. If pressure is not correct, adjust relief IN for more pressure and OUT for less pressure.

Track Tension Release

1. Locate manifold (**Figure 10-1,43**) under hopper to release track tension.

CAUTION Do not tamper with adjustment part of relief cartridge.

2. Back relief cartridge out of the aluminum block about three turns or until pressure release is heard.
3. Make sure cartridge is tightened before moving paver.

Conveyor Limit Switch Adjustment

In order for the conveyor's start and stop to occur at the correct position, small adjustments may be necessary to the micro-switch (**Figure 7-12,1**) located on the conveyor flap (**Figure 7-12,2**). There are two positions of the conveyor flap: one upper, shutting the conveyor OFF, and one lower, turning the conveyor ON. Read the following procedures carefully, referring to the figures as needed.

1. Raise the conveyor flap (**Figure 7-12,2**) 6-1/2 to 7 in. (16.5 to 17.8 cm) from bottom of the tank mount support (**Figure 7-12,3**). Secure conveyor flap so

it remains in this position. If micro-switch clicked OFF within the 6 1/2 to 7 in. (16.5 to 17.8 cm) limit, no further adjustment is required to the upper travel.

2. If the micro-switch (**Figure 7-12,2**) did not click OFF, adjustment is needed. Remove the linkage (**Figure 7-12,4**) attaching the actuator arm (**Figure 7-12,5**) to the eyelet on the flap pivot housing (**Figure 7-12,6**).
3. Loosen setscrew "A" (**Figure 7-13,1**), on the actuator arm (**Figure 7-13,2**). Reposition this arm by either rotating it clockwise or counterclockwise depending where the micro-switch clicked OFF during the conveyor flaps upward travel (see **Figure 7-13**).

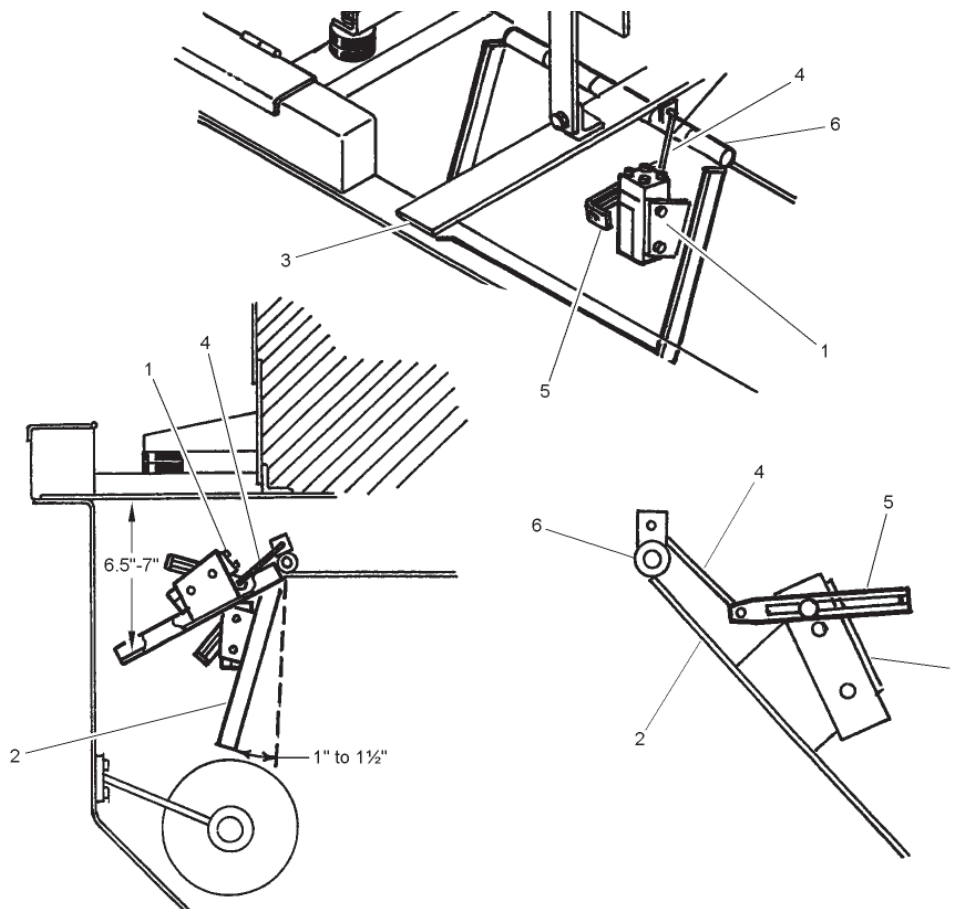

Conveyor Micro-Switch Location

Figure 7-12

- | | |
|------------------------|------------------------|
| 1 - Microswitch | 4 - Linkage |
| 2 - Conveyor Flap | 5 - Actuator Arm |
| 3 - Tank Mount Support | 6 - Flap Pivot Housing |

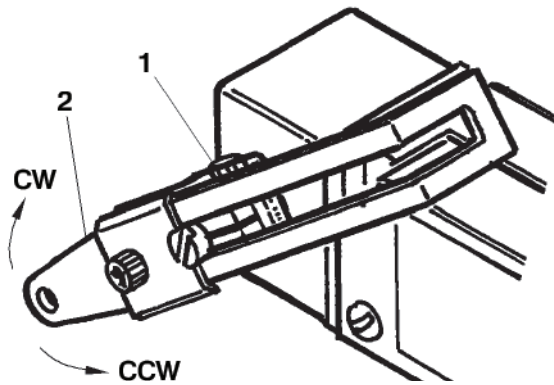

Setscrew "A" Location

Figure 7-13

- 1 - Setscrew A
- 2 - Actuator Arm

4. When the click OFF occurs between the 6-1/2 to 7 in. (16.5 to 17.8 cm) limit, tighten setscrew and connect linkage.
5. If the lower flap travel does not fall into the lower limits, loosen setscrew "B" (Figure 7-14,1) on the actuator arm (Figure 7-14,2) slightly.

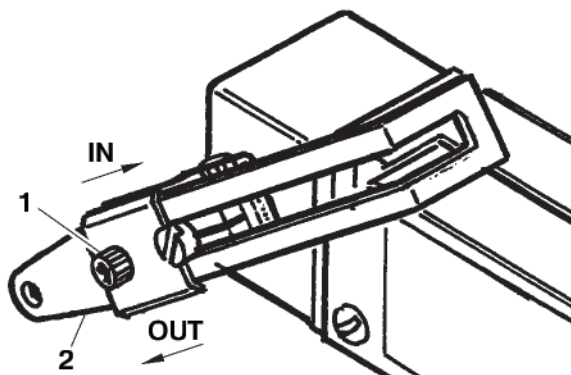

Setscrew "B" Location

Figure 7-14

- 1 - Setscrew B
- 2 - Actuator Arm

NOTE: The setting from the factory is 1 in. (2.54 cm) from the center of the setscrew "B" to the eyelet on the actuator arm.

6. To bring the travel limits into tolerance, slide the actuator arm in the direction desired. This may require several adjustments before the correct position is obtained. When the actuator arm is in the correct position, tighten setscrew "B". No further adjustment is necessary.

ELECTRICAL SYSTEM

NOTICE Use compressed air to blow dirt from generator monthly or more often if used in dirty environment. Do not use high pressure water.

Generator Voltage Testing

The LeeBoy Model Legend Electric Screed System generator is hydraulically driven. When the paver engine is at full rpm and the hydraulic system at normal operating temperature, the generator should produce between 220VAC and 240VAC.

The voltage of the generator depends on speed (rpm). The voltage increases as rpm increases, and decreases as rpm decreases. The voltage will decrease significantly if generator speed is slower than 3000 rpm.

NOTE: When testing the generator voltage ensure the paver engine is at full rpm and the hydraulic temperature is at normal operating levels.

To test the generator voltage at the generator:

1. Use volt meter to measure between the two main input wires L1 and L2 (Figure 7-15,2,3). If you measure from L1 to the frame of the paver, or ground, the voltage will be half of the rated output of the generator. The voltage should be the same as measured at the control box.

To test the generator voltage at the control box:

1. Use volt meter to measure between the two main black and white input wires located inside the control box on the terminal block similar to one in Figure 7-15. The voltage should be the same as measured at the generator.

If your voltage at this point is lower, make certain the generator is turning the correct speed (see *Generator Speed Tuning* in Section7).

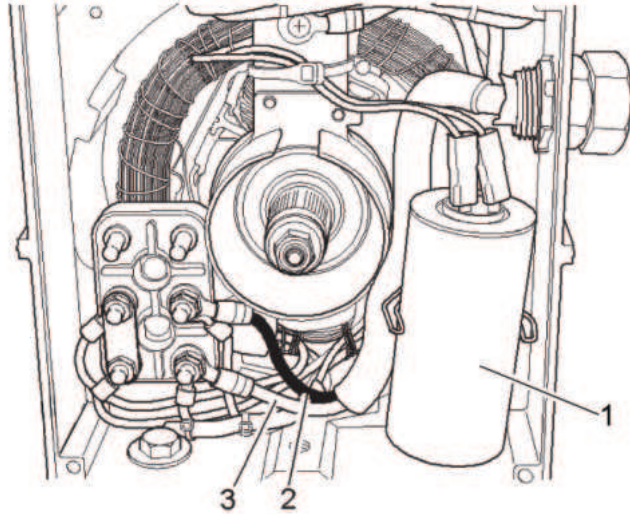

Generator Testing View

Figure 7-15

- 1 - Capacitor
- 2 - L1 (Black Wire)
- 3 - L2 (White Wire)

Generator Speed Tuning

NOTICE Generator speed tuning should only be done by an authorized LeeBoy Dealer.

A volt meter set to read frequency (Hz) can be used to test the speed of the generator. When the paver engine is at normal operating speed (approximately 1750 to 2000 rpm), the generator should operate at **58 Hz to 62 Hz**, or a speed of 3480 rpm to 3720 rpm. If generator speed drops below 3480 rpm, then voltage output and performance of the heating system will also decrease significantly.

NOTICE The generator should never be allowed to operate at a speed of 3800 rpm or greater. Generator damage will occur and may void your existing warranty. If your speed is above 3800 rpm, stop the set immediately.

NOTE: The generator and electrical system is designed to work within the range of 58 Hz to 61 Hz. It does not need to be set to exactly 60 Hz.

NOTE: When testing the generator speed, make certain that the paver engine is at full rpm and the hydraulic temperature is at normal operating levels.

To Measure Generator Speed:

1. Remove back panel from generator housing to access the rear of the generator.
2. Use volt meter, set to read frequency (Hz), to measure between the two main input wires L1 and L2 (Figure 7-15).

NOTE: A photo tachometer may also be used to check the speed of the generator at the motor coupling by removing the motor coupling shield.

CAUTION Always replace shields and panels when finished testing.

3. Note that 60 Hz is exactly 3600 rpm. For every single Hz above 60 an increase of 60 rpm can be added to 3600 rpm. For every single Hz below 60 Hz a decrease of 60 rpm can be subtracted from 3600 rpm.

Example: 60 Hz is 3600 rpm. A reading of 62 Hz would be 3720 rpm. A reading of 58 Hz would be 3480 rpm.

NOTE: The integrated flow control manifold is pre-set and will maintain the generator at its proper speed if the correct amount of oil is supplied to the set. If the temperature of the hydraulic system rises above 160°F, some slippage may occur through the gear set of the generator motor, and the generator may slow slightly.

To Fine Tune Generator Speed:

There is a fine tune adjustment (Figure 7-16,1) provided on the top of the manifold. This adjustment will only effect the speed of the generator a small amount. The manifold should not be out of adjustment any more than 1/8 turn of this adjustment.

NOTICE Over adjustment will cause damage to the generator and void the warranty.

NOTE: Generator Speed should only be adjusted by an Authorized LeeBoy Dealer.

4. Locate the Fine Tune Adjuster (Figure 7-16,1) and turn to increase or decrease the speed as needed.

NOTE: Clockwise (CW) adjustment will slow the generator down.

Counter Clockwise (CCW) adjustment will speed the generator up.

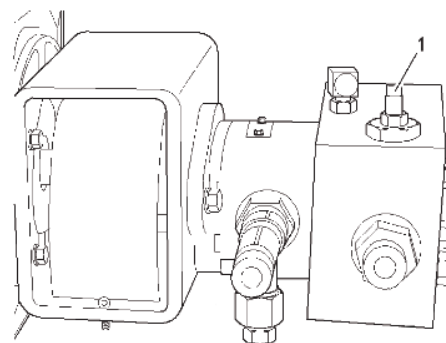

Generator Fine Tuning

Figure 7-16

1 - Fine Tune Adjuster

If your generator will not operate at the correct speed it may be necessary to test the hydraulic flow from the pump, or check the generator motor for excessive case drain flow. The case drain of the motor should not leak more than 1 gallon per minute. Replace the generator motor or paver pump if either are found to be operating incorrectly.

Generator Capacitor Replacement

The capacitor (**Figure 7-15,1**) located in the rear of the generator controls and regulates the voltage in the generator while in operation. If this capacitor fails, the voltage will drop to little or no output at all.

Replacing this capacitor with one of the same type and value will help determine if the capacitor is at fault.

To replace generator capacitor:

1. Ensure that the paver and generator engines are off.
2. Detach the wires at the top of the capacitor.
3. Remove the capacitor and replace with a new one of the same type and value.
4. Re-attach the leads at the top of the capacitor.

There are no other voltage adjustments that can be made to the generator.

Testing Element Relays

The element relays are 12vdc controlled, and have dual contacts rated for 240VAC.

To test element relay:

1. Disconnect any wires to the relay, or completely remove it from the control box (**Figure 7-17**).

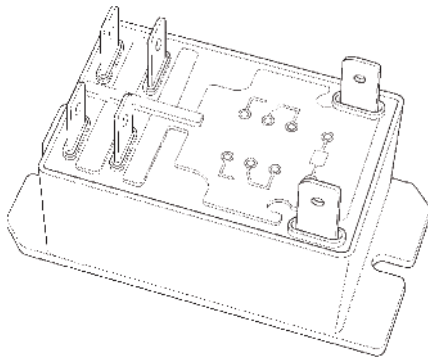

Relay

Figure 7-17

Place the leads of an ohm meter, or continuity tester across the contact terminals (2 to 4) or (6 to 8) as shown in **Figure 7-18**; **Figure 7-19**.

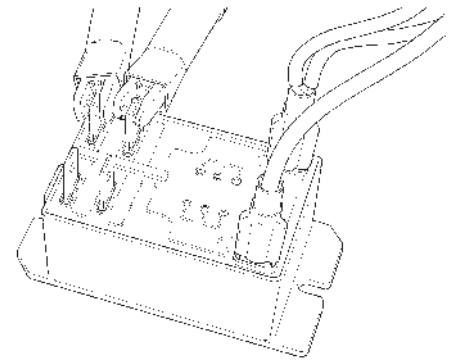

First Terminal Set Testing

Figure 7-18

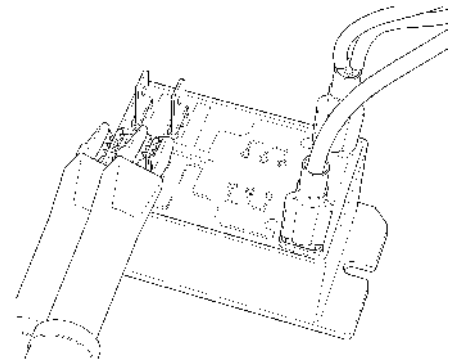

Second Terminal Set Testing

Figure 7-19

NOTE: Without 12vdc applied to the coil of the relay, the contact terminals should have no continuity through them. The contacts should be “open”. If the contacts are closed, and you do not have 12vdc applied to the coil of the relay, your contacts are not correct, and the relay should be replaced.

2. With the ohm meter still on the contact terminals, apply 12vdc to the coil terminals of the relay (**Figure 7-18**).

NOTE: The contact terminals should now close and show a path through them for the power to be applied to the electrical elements. If the relay does not work as described above, it may be faulty, and should be replaced.

Testing Element Resistance

When a breaker in the control box has tripped, it must be assumed that there may be a problem with wiring or an actual element in the circuit.

Elements used to heat the screed are sized depending on how much area and material they are required to heat. The actual resistance of the element will vary depending on what wattage the element is in the specific application.

To know that the element is correct, you should read a resistance between **28 ohms and 60 ohms**. If the element is bad, the reading will be very different from this range. The element that is bad will most likely read “open” or it will read very little resistance (less than 1 ohm) and will indicate a short through the element.

To test element resistance:

1. Disconnect element one at a time from the connection point on the lower side of the control box.
2. Use an ohm meter and test the resistance through the element between the two pins in the plug at the end of the element cable (**Figure 7-20**).

NOTE: You do not have to test the plug attached to the lower side of the control box.

3. Test between the two pins shown here with an ohm meter.
4. Test plug at end of element wires.
5. Before the element is plugged back in, check each wire (pin) with an ohm meter test lead, and place the other lead on a bare steel section of the screed frame. If there is any continuity through the element to the frame, the element is bad and must be left disconnected or replaced.

WARNING Fire Hazard! Do not attempt to operate an element with a known short. Replace faulty elements and wiring before using.

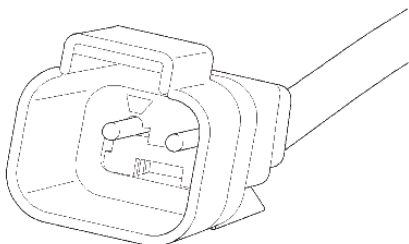

Element Plug End

Figure 7-20

Battery Servicing

WARNING Burn Hazard! Batteries contain sulfuric acid.

- NEVER allow battery fluid to come in contact with clothing, skin or eyes. Severe burns could result.
- ALWAYS wear safety goggles and protective clothing when servicing the battery.
- If battery fluid contacts the eyes and/or skin, immediately flush the affected areas with a large amount of clean water and obtain prompt medical treatment.

The paver electrical system is a 12-volt negative ground system. Keep sparks and flames away from the battery as electrolyte gas is highly flammable. The battery is located on the right side of the operator’s platform behind the disconnect switch.

WARNING Fire Hazard! Keep sparks and flames away from the batteries, as electrolyte gas is highly flammable.

NOTE: When replacing the battery, discard the old battery properly.

Before connecting the batteries, turn off the master switch, located underneath the main dash panel. Be certain that the terminals and battery posts are thoroughly cleaned and that the battery cable terminals are tight. Dirty or loose connections can create high electrical resistance and permit arcing.

NOTE: The electrical system is a negative ground system. Connect the positive (+) cable to the positive (+) post of the battery. Connect the ground cable to the negative (-) post of the battery. It is advisable to disconnect the negative (-) cable first and connect it last. Reversed polarity can damage the electrical system.

Keep the battery clean by washing it off whenever dirt builds up is excessive. If corrosion is present around terminal connections, remove them and wash with ammonia solution or a solution consisting of 1/4 lb. (0.11 kg) baking soda added to one quart of warm water. Make certain the vent caps are tight to prevent solution from entering the cells. After cleaning, pour clean water over the battery and surrounding area to wash the solution away. Check vent cap breather openings to make sure they are open.

⚠ WARNING Fire and Explosion Hazard! Be sure that the battery charger is in the OFF position before connecting it to the battery.

Be sure to keep the battery fully charged during cold weather to keep it from freezing. Freezing weather has little effect on a fully charged battery.

When connecting a booster battery, connect one end of the first jumper cable to the positive (+) terminal of the dead battery and the other end to the positive (+) terminal of the booster battery. Connect one end of the second jumper cable to the negative (-) terminal of the booster battery and the other end to the frame of the paver with the dead battery.

The alternator supplies electrical current for charging the battery and ample electrical power to the electronic controls. The built-in regulator in the alternator controls the voltage output. If for any reason the wires must be disconnected from the alternator, mark them so that they can be reconnected properly. Use the following precautions to prevent damage to the alternator and/or regulator:

1. An alternator is never to be polarized. Never ground any alternator terminals or circuits.

⚠ WARNING Fire and Explosion Hazard! Always observe battery polarity when connecting a battery charger or jumper cables to the battery: negative (-) to negative (-), positive (+) to positive (+). Failure to do so could produce sparks.

2. Always disconnect the battery before disconnecting or connecting the alternator. Never disconnect the alternator with it operating. Be certain the wiring is properly connected before connecting the battery.
3. Always connect a booster battery in the proper polarity: negative (-) to negative (-) and positive (+) to positive (+).

ENGINE MAINTENANCE

General Information

The following engine maintenance information will cover the engine general maintenance procedures most often required.

For additional, very specific, engine maintenance information, see the current engine manual.

Engine Lubrication Oil - Kubota

Checking Engine Lubrication Oil Level

The engine lubrication oil must be kept at a level above the “ADD” mark, but not above the “FULL” mark, on the engine lubrication oil dipstick.

To accurately check the engine lubrication oil level:

1. Park the LeeBoy Model 8500B Conveyor Paver in a “level” position and stop the engine.
2. Clean the area around the engine lubrication oil dipstick before removing the dipstick from the engine.

⚠ WARNING Stop the engine before checking the engine lubrication oil level. With the engine running, hot oil can be thrown causing serious injury.

3. Wait five minutes, after engine shutdown, before removing the dipstick from the engine and checking the oil level.

NOTE: The above procedure will help to remove the possibility of filling the engine with too much lubrication oil, by allowing the oil to return to the oil pan.

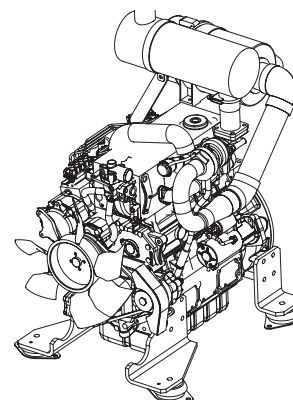

Kubota Engine

Figure 7-21

7

Changing Engine Lubrication Oil

The engine lubrication oil must be changed according to the interval given in the current Kubota Diesel engine operator's manual.

NOTE: The color of the engine lubrication oil can not be used as an indication of the need for a engine lubrication oil change. The use of an engine lubrication oil "analysis service" is the only alternate reason for not following the required engine lubrication oil change schedule.

WARNING Do not change the engine lubrication oil when the engine and lubrication oil are hot. Change when warm only. Hot oil can cause serious injury.

NOTICE Do not change the engine lubrication oil with the engine "running". Serious engine damage, or failure will occur. Clean the area around the engine lubrication oil dipstick and oil filler cap before removing the dipstick, or oil filler cap.

With the engine "stopped", and the engine lubrication oil is "warm", proceed as follows:

1. Clean the area around the engine lubrication oil drain hose found on the right side of the paver.
2. Place a container, having a capacity sufficient to hold the drained oil, directly under the engine lubrication oil drain plug.
3. Carefully remove the engine lubrication oil drain plug.
4. Using hose and fitting located on right-hand side of paver, drain all of the engine lubrication oil into the container.
5. Clean, install and carefully tighten the lubrication oil drain plug.

NOTICE Do not overtighten the drain plug.

6. Fill the engine with 15.0 qts (14.2 liters) of oil, using the correct engine lubrication oil (see **Specifications** in Section 4).
7. Install the engine lubrication oil dipstick.

NOTICE Do not start the engine before changing the engine lubrication oil filter. Follow the procedures given in this section and in the current Kubota engine manual.

Changing Engine Lubrication Oil Filter

The engine lubrication oil filter must be changed when the engine lubrication oil is changed.

WARNING Do not change the engine lubrication oil when the engine and lubrication oil are hot. Change when warm only. Hot oil can cause serious injury.

NOTICE Do not change the engine lubrication oil filter with the engine running. Serious engine damage, or failure, will occur.

With the engine "stopped" and filled with new engine lubrication oil, proceed as follows:

1. Wipe the area around the engine lubrication oil filter element and its mounting base, with a clean cloth.
2. Place a container under the filter element.
3. Use a filter removal wrench to loosen and remove the filter element by turning it in a counterclockwise (CCW) direction of rotation. Drain and discard the removed filter element.

NOTE: Be sure the used rubber gasket is removed and discarded with the filter element.

NOTE: Consider the environment when discarding used oil and do so according to safe and lawful practices.

4. Wipe the inside area of the lubrication oil filter head using a clean lint free cloth.
5. Put clean engine lubrication oil on the rubber gasket area of the new filter element. Fill the new filter element with correct, new, and clean oil.
6. Install the new filter element onto the filter head. Carefully tighten the filter element, by hand only.

NOTE: Tighten the filter element as directed on the filter element, by the filter manufacturer.

Engine Lubrication Oil - CAT

Checking Engine Lubrication Oil Level

The engine lubrication oil must be kept at a level above the “ADD” mark, but not above the “FULL” mark, on the engine lubrication oil dipstick.

To accurately check the engine lubrication oil level:

1. Park the LeeBoy Model 8500B Conveyor Paver in a “level” position and stop the engine.
2. Clean the area around the engine lubrication oil dipstick before removing the dipstick from the engine.

WARNING Stop the engine before checking the engine lubrication oil level. With the engine running, hot oil can be thrown causing serious injury.

3. Wait five minutes, after engine shutdown, before removing the dipstick from the engine and checking the oil level.

NOTE: The above procedure will help to remove the possibility of filling the engine with too much lubrication oil, by allowing the oil to return to the oil pan.

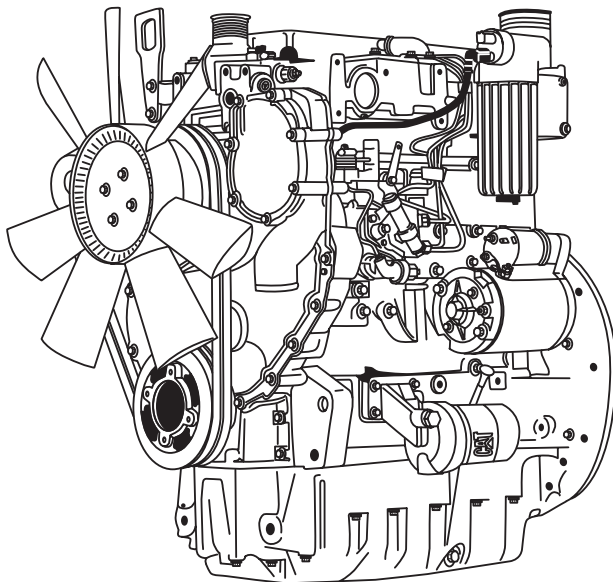

CAT Engine

Figure 7-22

Changing Engine Lubrication Oil

The engine lubrication oil must be changed according to the interval given in the current Kubota Diesel engine operator’s manual.

NOTE: The color of the engine lubrication oil can not be used as an indication of the need for a engine lubrication oil change. The use of an engine lubrication oil “analysis service” is the only alternate reason for not following the required engine lubrication oil change schedule.

WARNING Do not change the engine lubrication oil when the engine and lubrication oil are hot. Change when warm only. Hot oil can cause serious injury.

NOTICE Do not change the engine lubrication oil with the engine “running”. Serious engine damage, or failure will occur. Clean the area around the engine lubrication oil dipstick and oil filler cap before removing the dipstick, or oil filler cap.

With the engine “stopped”, and the engine lubrication oil is “warm”, proceed as follows:

1. Clean the area around the engine lubrication oil drain hose found on the right side of the paver.
2. Place a container, having a capacity sufficient to hold the drained oil, directly under the engine lubrication oil drain plug.
3. Carefully remove the engine lubrication oil drain plug.
4. Using hose and fitting located on right-hand side of paver, drain all of the engine lubrication oil into the container.
5. Clean, install and carefully tighten the lubrication oil drain plug.

NOTICE Do not overtighten the drain plug.

6. Fill the engine with 10.6 qts (10.0 liters) of oil, using the correct engine lubrication oil (see **Specifications** in Section 4).

7. Install the engine lubrication oil dipstick.

NOTICE Do not start the engine before changing the engine lubrication oil filter. Follow the procedures given in this section and in the current CAT engine manual.

7

Changing Engine Lubrication Oil Filter

The engine lubrication oil filter must be changed when the engine lubrication oil is changed.

WARNING Do not change the engine lubrication oil when the engine and lubrication oil are hot. Change when warm only. Hot oil can cause serious injury.

NOTICE Do not change the engine lubrication oil filter with the engine running. Serious engine damage, or failure, will occur.

With the engine “stopped” and filled with new engine lubrication oil, proceed as follows:

1. Wipe the area around the engine lubrication oil filter element and its mounting base, with a clean cloth.
2. Place a container under the filter element.
3. Use a filter removal wrench to loosen and remove the filter element by turning it in a counterclockwise (CCW) direction of rotation. Drain and discard the removed filter element.

NOTE: Be sure the used rubber gasket is removed and discarded with the filter element.

NOTE: Consider the environment when discarding used oil and do so according to safe and lawful practices.

4. Wipe the inside area of the lubrication oil filter head using a clean lint free cloth.
5. Put clean engine lubrication oil on the rubber gasket area of the new filter element. Fill the new filter element with correct, new, and clean oil.
6. Install the new filter element onto the filter head. Carefully tighten the filter element, by hand only.

NOTE: Tighten the filter element as directed on the filter element, by the filter manufacturer.

FUEL SYSTEM

Fuel Tank

The fuel level is indicated on the dash panel FUEL gauge and indicates the amount of fuel in the tank. Fill the fuel tank “FULL”.

NOTE: Fill the tank, to “FULL” before the paver is stored for the night to reduce the accumulation of moisture, in the tank, from condensation.

WARNING The operator must be off of the paver while fuel is added. No smoking while filling the fuel tank. All fuels for internal combustion engines are flammable. Fill the fuel tank only in a designated area with good ventilation. Have a fire extinguisher available.

WARNING Never fill the tank near an open flame, or near equipment that can create sparks. Never check fuel level or check for fuel leaks with an open flame.

Engine Fuel Filters

The fuel filter element must be replaced as directed in the current engine operator's manual. Replace the fuel filter using the following "general" procedure and specific information given in the current engine operator's manual.

WARNING Diesel fuel is very flammable. Use extra caution.

Do not change the fuel filter with the paver running.

Do not change the fuel filter in an area near an open flame. Do not smoke while changing the fuel filter.

Do not spill fuel.

1. Stop the engine.
2. Put a container under the fuel filter, before removing the filter element.

NOTE: Consider the environment when discarding used oil and do so according to safe and lawful practices.

3. Wipe the area around the fuel filter element and the element mounting head, using a clean lint free cloth.
4. Use a filter removal wrench to loosen and remove the element, by turning the element in a clockwise direction. Drain and discard the removed element.
5. Wipe the inside area of the filter head with a clean "lint free" cloth. Fill the "new" fuel filter element completely full of the correct and clean fuel.
6. Put clean fuel on the element rubber gasket.
7. Install the "new" fuel filter element onto the filter head. Carefully tighten the element by hand only.

NOTICE Tighten the fuel strainer or the fuel filter element as directed on the filter element, by the filter manufacturer. Do not overtighten the fuel filter element onto the filter head.

8. Start the engine and check for ANY fuel leaks.

WARNING Stop the engine immediately if any fuel leakage is noted. Do not start the engine until the leakage problem is corrected.

Engine Air Filter

The engine inlet air filter assembly uses a replaceable filter element.

NOTICE The air filter element should be replaced one time for each 100 hours of paver operation, or monthly, for a paver which is operated under "normal" conditions, or more often for a paver that is operated under "very severe conditions. Never operate the engine without an air cleaner element installed.

Do not service the air cleaner element while the engine is "running".

Use the following procedures to service the air cleaner element:

1. Remove the two screws and plate securing each air filter cover over the air filters at the top of the engine.
2. Remove the air filter covers.
3. Remove the air filter elements from the engine and discard.
4. Clean the inside of the air cleaner body with a clean cloth.

NOTICE Severe engine damage can occur if engine is operated without air filter properly installed.

5. Carefully install the new air filter elements into the intake at the top of the engine.
6. Install the covers over the filters.
7. Secure each cover with the two screws and plate.
8. Start the engine using all the correct starting procedures (see **Starting The Engine** in Section 6).
9. Check that engine runs smoothly.

HYDRAULIC SYSTEM

General Information

The hydraulic motors and the hydraulic cylinders use the same hydraulic oil reservoir and hydraulic oil supply.

Checking Hydraulic Oil Level

Check the hydraulic reservoir oil level, one time each day, by looking at the sight gauge on the reservoir. Check the oil level when the hydraulic oil is at “normal” operating temperature only.

WARNING Do not loosen, or remove, the hydraulic oil reservoir filler cap when the hydraulic oil is “HOT”. Always loosen the filler cap slowly to relieve any pressure in the hydraulic oil reservoir.

WARNING Only loosen the filler cap when the oil is at a “WARM” temperature.

Adding Hydraulic Oil To Hydraulic Oil Reservoir

The hydraulic reservoir oil level must be visible in the sight gauge (**Figure 7-23,1**) to be at the correct level. If the hydraulic oil level is below the sight gauge, the correct, filtered hydraulic oil (see **Specifications** in Section 4) must be added to the hydraulic oil reservoir until the oil level is shown to be full in the sight gauge.

WARNING Do not remove the hydraulic filler cap from the reservoir when it is “HOT”. Hot hydraulic oil can cause serious injury. Allow hydraulic oil to cool down to a warm temperature.

1. Unscrew hydraulic oil tank filler cap (**Figure 7-23,2**).

NOTICE Do not over fill the hydraulic oil reservoir.

2. Add needed amount of new, filtered hydraulic oil.
3. Keep the oil level of the hydraulic oil reservoir at the correct level.

NOTE: An air space is designed into the hydraulic oil reservoir and allows for oil expansion, at warm temperatures. The hydraulic oil reservoir will have a low pressure in it at system operating temperatures.

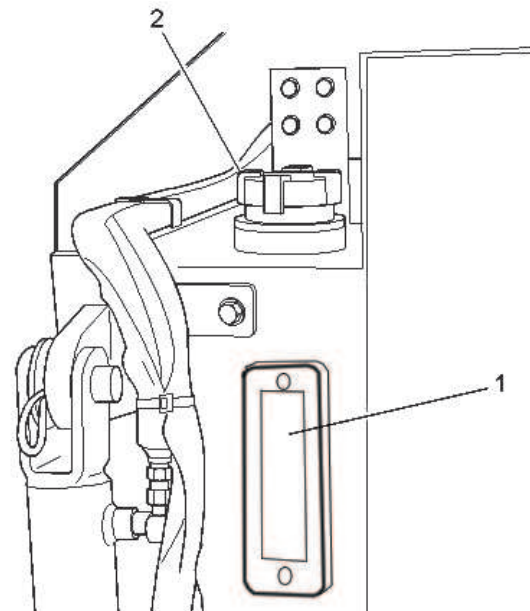

Hydraulic Oil Tank

Figure 7-23

1 - Sight Gauge (Oil Level/Temperature)

2 - Filler Cap

Changing Hydraulic Oil

Changing the hydraulic oil removes the accumulation of dirt, water and mechanical wear particles from the hydraulic oil reservoir and system. The chemical structure of the hydraulic oil also changes after continuous use in the system and new, clean, and filtered oil is a must to help insure further correct operation of the hydraulic system.

NOTICE Hydraulic oil which has oxidized or which contains contamination, of any type, can shorten the expected service life of any, or all, of the components in the hydraulic system.

Use the following procedures to change the hydraulic oil in the hydraulic oil tank (Figure 7-23).

1. Stop the engine. Allow the hydraulic oil to cool, until it is at a warm temperature only. Slowly loosen, and then remove, the hydraulic oil reservoir filler cap (Figure 7-23,2). Put a CLEAN, lint free cloth over the reservoir fill tube opening and secure in place with tape.

WARNING Do not drain the hydraulic oil from the reservoir when it is "HOT". Hot hydraulic oil can cause serious injury. Drain at a warm temperature only.

NOTE: All reservoir tanks together plus hoses hold approximately 40 gallons.

2. Carefully remove the plugs from the hydraulic tanks. Use a drain collection device, of sufficient capacity to collect the hydraulic oil. Allow all of the hydraulic oil to drain from the reservoirs and into the container.

NOTICE Do not fill the hydraulic oil reservoir with new hydraulic oil until the strainer has been serviced.

3. Install the hydraulic oil reservoir drain plug, and tighten securely.
4. Carefully remove the cloth from the hydraulic oil reservoir fill tube opening.

5. To be sure the bottom oil tank is properly filled, proceed as follows:
 - a. Remove the strainer on the top tank.
 - b. Fill the top hydraulic oil tank with the correct, filtered hydraulic oil until tank is full.
 - c. Crank engine and let pump transfer oil from top tank to bottom tank.
 - d. Monitor oil level in top tank. When oil level is below one-half full, shut off engine and refill top tank.
 - e. Repeat this process until proper level is obtained.

NOTICE Do not overfill the hydraulic oil reservoir with oil.

NOTICE Never let tank run dry. Pump damage will occur.

6. Check the oil level in the hydraulic oil reservoir, again. Add oil if needed.
7. Install the hydraulic oil reservoir filler cap onto the reservoir filler neck and tighten securely.
8. Start the engine using the correct procedures (see *Starting The Engine* in Section 6).
9. Check the hydraulic system for any leaks.

WARNING Do not use the hands on any hydraulic hose, fitting or system component to check the system for possible leaks. Serious injury can result from an oil leak under high pressure. Oil can be injected under the skin by high pressure. Protect the eyes by wearing safety glasses.

CAUTION Stop the engine immediately if any hydraulic leak is noted. Do not start the engine until any problem noted has been corrected.

Changing Hydraulic Oil Strainer

The oil strainer is mounted in the oil filler opening under the filler cap (Figure 7-23,2).

WARNING Do not remove the hydraulic filler cap from the reservoir when it is "HOT". Hot hydraulic oil can cause serious injury. Allow hydraulic oil to cool down to a warm temperature.

1. Remove the hydraulic oil filler cap (Figure 7-23,2).
2. Remove the three screws securing the strainer, then remove the strainer and the gasket.
3. Install a new gasket, aligning the three holes in the gasket with the mounting holes on the reservoir.
4. Install the new strainer, aligning the holes in the strainer with the mounting holes of the gasket and secure the strainer with the three screws.
5. Fill the hydraulic oil reservoir with the correct, filtered hydraulic oil until visible in the sight gauge (Figure 7-23,1).

NOTICE Do not overfill the hydraulic oil reservoir with oil.

6. Check the oil level in the hydraulic oil reservoir, again. Add oil if needed.
7. Install the hydraulic oil reservoir filler cap onto the reservoir filler neck and tighten securely.

REMOVAL & INSTALLATION PROCEDURES

Track Component Replacement Idler

1. Raise conveyor and insert safety prop (see *Raising Conveyor* in Section 7).
2. Locate track tension manifold (Figure 10-1,43), then back the relief cartridge out of the aluminum block about three turns or until you hear the tension pressure release.

NOTE: The following step is for poly/steel tracks only.

3. Rotate track so that the master link is at the rear bottom of the front idler (Figure 10-1,14), then remove the master pin (Figure 10-1,28). Once master pin is removed, back up the paver until the track clears the front idler.
4. Jack up the paver on the side needing to be repaired.
5. Remove the clip pin from the cylinder rod and idler bracket.
6. The idler will slide straight out.
7. Remove idler bracket and bolt to new idler.
8. Install idler making sure cylinder and clip pin are in correct position.
9. Lower sprocket back down toward track chain, keeping sprocket about 1 in. (2.54 cm) out of chain.

NOTE: The following step is for poly/steel tracks only.

10. Pull track to front of paver so that track laying on ground can be hooked on to, then reverse sprocket to rotate track to top so that master pin (Figure 10-1,28) will go in at rear of idler (Figure 10-1,14).
11. Tighten tension relief, start paver, and rotate the track to make sure it is OK. When finished remove the jack.

Cylinder

1. Raise conveyor and insert safety prop (see **Raising Conveyor** in Section 7).
2. Locate the track tension manifold (**Figure 10-1,43**). Then, back the relief cartridge out of the aluminum block about three turns, or until you hear the tension pressure release.

NOTE: The following step is for poly/steel tracks only.

3. Rotate the track so that the master link is at the rear bottom of the front idler (**Figure 10-1,14**). Then remove the master pin (**Figure 10-1,28**). Once the master pin is removed, back the paver until the track clears the front idler.
4. Jack up the paver on the side needing to be repaired and remove the front track roller.
5. Remove the clip pin from the cylinder rod and the idler bracket.
6. The idler will slide straight out at this time.
7. Grab the cylinder and pull it toward the front so that you can remove the hose from the cylinder bottom.
8. Replace the cylinder or repack the seal kit and install in paver.
9. Install the idler making sure the cylinder and the clip pin are in correct position.
10. Lower sprocket back down toward track chain, keeping sprocket about 1 in. (2.54 cm) out of chain.

NOTE: The following step is for poly/steel tracks only.

11. Pull track to front of paver so that track laying on ground can be hooked on to, then reverse sprocket to rotate track to top so that master pin (**Figure 10-1,28**) will go in at rear of idler (**Figure 10-1,14**).
12. Tighten tension relief, start paver, and rotate the track to make sure it is OK. When finished remove the jack.

Rollers

1. Raise conveyor and insert safety prop (see **Raising Conveyor** in Section 7).
2. Locate the track tension manifold (**Figure 10-1,43**). Then back the relief cartridge out of the aluminum block about 3 turns or until you hear the tension pressure release.
3. Jack the paver up on the side needing the repair.
4. Remove the rollers that are faulty and replace them with new ones. Torque bolts to 90 ft. lbs. (122 N•m).
5. Tighten the tension relief. Then start the paver and rotate the track to make sure it is OK. When finished remove the jack.

Rubber Track Replacement

Removal

1. Jack paver off ground 24 in (61 cm) so that complete undercarriage has enough clearance to come out and properly support paver.
2. Raise conveyor and insert safety prop (see *Raising Conveyor* in Section 7).
3. Loosen track tension cartridge at manifold located at rear of bottom hydraulic tank (**Figure 10-4,16**).
4. Label and disconnect the track tension hoses from undercarriage at track tension manifold (**Figure 10-1**).
5. Cap and plug all the hoses.
6. Remove generator cord at generator if removing left undercarriage (Electric Heat only).
7. Remove the two (2) bolts (**Figure 10-2,23**) holding the drive motor (**Figure 10-2,3**) to the torque hub (**Figure 10-2,4**) and leave on paver.
8. Support the undercarriage (**Figure 10-2**) with a forklift or jack before lowering to ground.
9. Unbolt the 2 trunions (**Figure 10-2**) on the front of track undercarriage and stops at rear of undercarriage from each side.
10. Lower the whole track assembly (**Figure 10-2**) down and lay on side.
11. Remove rubber track (**Figure 10-2,12**) by prying from idler end first.

NOTE: At this time Idler, Torque Hub, Sprocket, Rollers, and Cylinder should be replaced if needed. Undercarriage must be lowered before replacing above components except Rollers.

Installation

1. Replace any worn or broken components if needed.
 2. Install the new rubber track (**Figure 10-2,12**) where old one was removed starting at sprocket end first.
 3. Raise undercarriage into paver and place trunions and rear stops. Remove jack or lifting device.
 4. Check O-ring, replace if worn. Reinstall the motor (**Figure 10-2,3**) and torque the bolts (**Figure 10-2,23**) to proper specs.
 5. Connect track tension hoses to manifold and tighten track tension cartridge back down.
 6. Connect generator cord to generator (Electric Heat only).
 7. Fill torque hub (see *100-Hour or Monthly Routine Maintenance* in Section 7) with specified oil (see *Specifications* in Section 4).
 8. Lower paver to ground.
- NOTICE** Make sure hose connections are clean before removing and also before installing.
9. Lower conveyor and bolt hopper wings down.
 10. Run paver and check for any leaks.

Torque Hub Replacement

Removal

1. Raise conveyor and insert safety prop (see *Raising Conveyor* in Section 7).
2. Loosen track tension cartridge in manifold (located on rear of bottom hydraulic tank) until pressure leaks off.
3. Remove master pin in track chain behind front idler on bottom side.
4. Back paver up until track lays flat on ground.
5. Jack paver up approximately 24 in (61 cm) off ground and place on sturdy jack stands.
6. Remove the two cap screws (**Figure 10-1,47**) and lock washers (**Figure 10-1,48**) attaching the hydraulic drive motor (**Figure 10-1,44**) to the torque hub drive (**Figure 10-1,4**).

NOTE: Do not disconnect hoses from the hydraulic drive motor. Hoses are long enough to slide motor out and place out of way.

NOTE: Mark location of torque hub to frame before removing to assure that drive motor is reinstalled in same position.

NOTE: Sprocket can be removed at this time before torque hub is taken out by removing bolts in sprocket and removing track roller.

7. Remove bolts holding torque hub to track undercarriage.

NOTE: Before completely removing all bolts from torque hub, place jack or other method underneath to safely lower torque hub to ground.

Installation

NOTE: The torque hub on the right side is rotated one (1) bolt hole different than the left side.

1. Install torque hub in proper position for drive motor to line up.
2. Place thread-locking adhesive on torque hub bolts and torque all bolts to specification (see *Specifications* in Section 4).
3. Check O-ring on drive motor, replace if worn. Bolt drive motor to torque hub.
4. Place thread-locking adhesive on sprocket bolts and torque all bolts to specification (see *Specifications* in Section 4).
5. Reinstall rear track roller if previously removed.
6. Fill torque hub (see *100-Hour or Monthly Routine Maintenance* in Section 7) with specified oil (see *Specifications* in Section 4).
7. Lower paver to ground and reconnect track.

NOTE: Removing pad from chain where master pin is placed will make reconnecting track easier from top side at idler rear.

8. Tighten track tension cartridge down.
9. Lower paver to ground.

NOTICE Make sure hose connections are clean before removing and also before installing.

10. Lower conveyor and bolt hopper wings down.

WARNING Do not use the hands on any hydraulic hose, fitting or system component to check the system for possible leaks. Serious injury can result from an oil leak under high pressure. Oil can be injected under the skin by high pressure. Protect the eyes by wearing safety glasses.

11. Start the engine using the correct procedures (see *Starting The Engine* in Section 6).
12. Check the hydraulic system for any leaks.

CAUTION Stop the engine immediately if any hydraulic leak is noted. Do not start the engine until any problem noted has been corrected.



Rear Conveyor Shaft Replacement

Removal

1. Rotate flight chains (**Figure 10-3,2**) until C-188 master pin (**Figure 10-3,15**) is located. When located, rotate the master pin to the rear of the conveyor drive sprocket.

NOTE: If the shaft (**Figure 10-3,8**) is broken, the front shield with rubber needs to be removed, then push against the outer edge of the conveyor bars to make the chains rotate.

2. Remove grating walkway from paver so that you can reach in to the center of conveyor at rear, or lay in under engine platform to reach center.
3. Push back the rubber shield at the center of the conveyor at the rear so that the snap ring (**Figure 10-3,9**) can be removed off the shaft.
4. Run screed extension out fully on side to be changed.

NOTE: The front screed arm bolt may need to be removed to tilt arm out of the way.

5. Remove the chain guard and 80 chain that drives the conveyor.

NOTE: The flight chains can be loosened to allow the shaft to come out easier.

6. Remove capscrew (**Figure 10-3,1**) and countersunk washer (**Figure 10-3,2**) then remove the outer 80 drive sprocket (**Figure 10-3,3**).
7. Remove the four capscrews (**Figure 10-3,10**) and washers (**Figure 10-3,11**), then remove conveyor mounting plate with bearing (**Figure 10-3,4**).

NOTE: Do not remove the master pin on the inner C-188 chain. Let the sprocket and chain stay together.

8. Remove C-188 master link (**Figure 10-3,13**) and lay the chain away from the sprocket on the outer side.
9. The rear shaft (**Figure 10-3,8**) and outer C-188 sprocket (**Figure 10-3,5**) will pull straight out at this time.

Installation

1. Slide the new shaft (**Figure 10-3,8**) in and align the inner C-188 sprocket (**Figure 10-3,6**) onto the spline shaft.
2. Install the snap ring (**Figure 10-3,9**) on and fasten the rubber shield back.
3. Install the outer C-188 sprocket (**Figure 10-3,5**), be sure that the teeth are in line with the inner C-188 sprocket.
4. Install the pivot bearing plate (**Figure 10-3,4**) using the four capscrews (**Figure 10-3,10**) and lockwashers (**Figure 10-3,11**).
5. Apply thread-locking adhesive on taper head bolt (**Figure 10-3,1**).
6. Attach the outer drive sprocket (**Figure 10-3,3**) with taper headed bolt (**Figure 10-3,1**) and countersunk washer (**Figure 10-3,2**).
7. Put 80 chain on and lubricate the chain.
8. Adjust chain for about 1/4 in. (0.64 cm) play.
9. Place chain guard back on.
10. Hook screed arm in place.
11. Adjust main flight chains and let the conveyors run for a short period of time. Then recheck the chain adjustment.
12. Place grating back on when finished.

NOTE: Conveyors should be adjusted about every 100 hours to avoid damage to the conveyor rear shafts and the chains.

NOTE: Keep the conveyors clean and well lubricated.

NOTE: If the conveyor or flight chains are adjusted all the way out, locate the master link and remove it. Remove 1 block link and 2 sidebars on each chain, then replace with C-188 1/2 links. (There is not enough room to take a link out without installing a 1/2 link back).

Auger And Inner Bearing Replacement

Removal

1. Remove rear grating over auger assembly.
2. Run screed extension all the way out.

NOTE: This provides room to stand in behind auger back to remove top portion of auger cover. Auger cover is in three pieces with a small tack to hold cover together while building.

3. Remove four nuts holding cover (**Figure 10-5,1**) on and pry cover apart.
4. Clean asphalt build up from around cover.

NOTE: Heating asphalt may be required.

5. Remove middle and bottom portion of cover by laying on conveyor under engine.
6. Rotate augers so that master link is centered at front.
7. Loosen auger chains by sliding auger motors (**Figure 10-5,4**) down from backside after loosening the two bolts securing mounting brackets (**Figure 10-5,5**).
8. Remove auger endmounts (**Figure 10-5,8,9**) so that augers can be removed through opening in sides.
9. Remove augers (**Figure 10-5,15,16**) and lay augers on the ground in the same position as removed. This will help insure proper installation of the new augers.
10. Check inner auger bearing (**Figure 10-5,12**) and replace at this time if faulty.

Installation

NOTE: When installing the new augers be sure to align augers the same as the removed augers. It is very easy to install augers backwards.

1. Install new augers (**Figure 10-5,15,16**) making sure that wear plates are on correct side to auger material outward.
2. Tighten bearing setscrew to help hold auger shaft from moving outward.
3. Slide auger collar (**Figure 10-5,6**) on end of auger shaft and bolt endmount (**Figure 10-5,8,9**) back on. Torque mounting screws to 78 ft. lbs. (106 N•m)
4. Push collar (**Figure 10-5,11**) all the way in against endmount (**Figure 10-5,8,9**) and attach with setscrews (four setscrews, two on outside and two on inside).
5. Replace bronze bushing (**Figure 10-5,7**) in the endmounts.
6. Place auger chains back on and adjust auger motors (**Figure 10-5,4**) up to tighten chains. Use a pry bar under motor to pry up, then snug bottom motor mount bolts (make sure chains have approximately 1/4" of slack).
7. Make sure motor is level then tighten top and bottom bolts. to a torque of 150 ft. lbs. (155 N•m). Do the same for the other side.
8. Lubricate chains.
9. Place auger cover (**Figure 10-5,1**) back in place making sure slot for auger shaft is sealed shut.
10. Place grating back on over auger.
11. Run augers and make sure everything is correct.

NOTE: Auger chains can be lubricated each day by spraying oil or chain lube in through slots where auger motor is adjusted.

Screed Extensions, Slides Or Bushing Replacement

NOTE: When replacing bushings, the bushings need to be honed if 1-1/2" rods (**Figure 10-38,4**) do not slide in.

Removal

1. Remove cylinder covers (**Figure 10-34,19,20**).
2. Run screed extension out completely.
3. Remove cylinder pin (**Figure 10-48,6**).
4. Remove the four 1/2" bolts (**Figure 10-38,9**) lockwashers(**Figure 10-38,8**), and flat washers (**Figure 10-38,7**) in extension rods (**Figure 10-38,6**) holding the extension on.
5. After bolts have been removed, pull extension out of the way.
6. Pull 1-1/2" rods (**Figure 10-38,6**) out of slide (**Figure 10-38,2**).
7. Loosen five bolts (**Figure 10-34,21**) attaching top guide (**Figure 10-34,17**). This will let main slide (**Figure 10-38,2**) come out easily. At this time bushings (**Figure 10-38,4**) can be replaced or main slide can be replaced.

Installation

1. Clean area where slides (**Figure 10-38,2**) are installed, and lubricate before reinstalling the slide.
2. Loosen guide (**Figure 10-38,17**) and drive guide down tight against slide by using allen set screws.
3. Slide 1-1/2" rods (**Figure 10-38,6**) back into slide (**Figure 10-38,2**).
4. Secure rods (**Figure 10-38,6**) with capscrew (**Figure 10-38,9**) lockwasher (**Figure 10-38,8**), and flat washers (**Figure 10-38,7**).
5. Make sure extension is mounted flush with bottom of screed plate.
6. Hook cylinders (**Figure 10-48,1,2**) back to extensions using pin (**Figure 10-48,6**) and put cylinder cover (**Figure 10-34,19,20**) back on.
7. Run extension out and grease the extension well before operating "in" and "out".

Screed Wear Plate Replacement

Removal

1. Run screed extension all the way in.
2. Remove the cylinder covers, (**Figure 10-34,19,20**) the walkboards (**Figure 10-37,1**), and the screed lids (**Figure 10-34,7**).
3. Remove the twenty-four (24) 3/8" bolts holding the wear plate (**Figure 10-34,13**) to the screed frame on each side.
4. Clamp the center portion of the screed frame so that when the screed frame is raised up off the worn wear plate the clamp will hold the frame in place.
5. Raise the screed up and remove the worn wear plate.
6. Clean all material buildup from the screed frame before bolting in the new wear plate.

Installation

1. Set the new wear plate down level on 3 blocks, placing one block in the center and one at each end. Make certain the extensions are raised all the way up to prevent extensions from holding the screed frame off the wear plate.
 2. Lower the screed frame down on the new wear plate.
- NOTE: Do not tighten the bolts in the next step until all the bolts are installed.
3. Install five bolts in one side at the front to hold the wear plate.
 4. Loosen the vibrator on the slotted side and adjust the crown. This will move the screed frame in and out on the wear plate to help align the bolts on the opposite side.
 5. Once the front bolts are installed install the rear bolts.
 6. When all of the bolts have been started make sure the screed frame and the wear plate are flat.
 7. Torque bolts to 55 ft. lbs. (74 N•m). Start inside and move outward by rotating from the left to the right side. This will keep the screed relaxed.
 8. Place the screed lids, the walkboards and the cylinder covers back on the screed.

Extension Wear Plate Replacement

Removal

1. Run the extensions all the way out.
2. Remove the endgates by removing the tilt screw and 7/8" nut on each side. The endgate will tilt forward out of the holder and slide off the 7/8" bolt.
3. Disconnect the extension adjuster (**Figure 10-39,4**) from the wear plate (**Figure 10-39,2**), by removing locknut, washer, and shoulder bolt (**Figure 10-39,6**).
4. Remove the front extension hinge shield (**Figure 10-39,16**).
5. Slide the hinge pin (**Figure 10-39,8**) out and the wear plate (**Figure 10-39,2**) will fall off.

Installation

1. Hold the new wear plate (**Figure 10-39,2**) in place and slide the hinge pin (**Figure 10-39,8**) in place.
2. Fasten the extension adjuster (**Figure 10-39,4**) back to the wear plate (**Figure 10-39,2**) with locknut, washer, and shoulder bolt (**Figure 10-39,6**).
3. Put the front hinge shield (**Figure 10-39,16**) back on.
4. Install endgate and tilt screw back on the paver.

Tandem Servo Pump Replacement

Removal

1. Remove the right side cover.
2. Remove the right side access door cover.
3. Remove the top right side cover and right side cover.
4. Label and disconnect the hoses to the tandem propulsion hydraulic pump, plugging the hoses and capping the fitting on the hydraulic pump.
5. Label and disconnect the hoses to the tandem auxiliary hydraulic pump (16), plugging the hoses and capping the fitting on the hydraulic pump.

NOTE: If Tandem Auxiliary Pump is not bad leave hoses attached and slide out of Main Pump.

CAUTION Pump assembly is very heavy and must be properly supported with a sling before loosening mounting bolts.

6. Place a sling around the pump assembly to provide support.
7. Remove the two screws attaching pump assembly (16) to the pump plate cover.
8. Slide the pump assembly off of the splined shaft.
9. Using the sling, lift pump assembly with auxiliary pump assembly out of paver and place on a flat surface.
10. Remove the two screws attaching the tandem auxiliary hydraulic pump to the tandem propulsion hydraulic pump.
11. Remove the o-ring from between the pumps.

Installation

1. Place a small amount of hydraulic oil on the oring and install o-ring between the pumps.
2. Carefully support auxiliary pump and align the mounting holes in the auxiliary pump with the mounting on pump.
3. Attach the pumps with the two mounting screws.
4. Torque the screws to 89 ft. lbs. (121 N•m).

⚠ CAUTION Pump assembly is very heavy and must be properly supported with a sling before loosening mounting bolts.

5. Support the complete pump assembly with a sling and lift assembly into paver.
6. Carefully slide pump assembly onto splined shaft and align mounting holes with the pump plate cover mounting holes (grease splines before installing).
7. Attach the pumps with the two mounting screws.
8. Torque the screws to 89 ft. lbs. (121 N•m).
9. Remove plugs and caps and connect hydraulic hoses to pumps are previously labeled.
10. Check hydraulic oil level in tank and add hydraulic oil if necessary.
11. Install the right side cover.
12. Install the right side access door cover.
13. Install the top right side cover and right side cover.
14. Install the spray hose assembly on the top right side cover.
15. Start the paver.
16. Check to be sure there is no hydraulic oil leaks.

2-Speed Hydraulic Motor Replacement

Removal

1. Turn the paver off.
2. Check to be sure there is no hydraulic pressure.
3. Label and disconnect the hoses to the hydraulic motor (**Figure 10-1,44**).
4. Plug the hoses and cap the fitting on the hydraulic motor.
5. Support hydraulic motor, then remove the two screws (**Figure 10-1,47**) and lockwashers (**Figure 10-1,48**) attaching the hydraulic motor to the torque hub and carefully remove the motor from the torque hub.
6. Remove the o-ring (**Figure 10-1,46**).
7. Drain the hydraulic oil from the hydraulic motor. Discard or repair the hydraulic motor as appropriate.

Installation

1. Lubricate a new o-ring (**Figure 10-1,46**) with hydraulic oil and install on torque hub.
2. Attach hydraulic motor to torque hub using two capscrews (**Figure 10-1,47**) and lockwashers (**Figure 10-1,48**).
3. Torque capscrews (**Figure 10-1,47**) to 120 ft. lbs (163 N•m).
4. Remove plugs from hydraulic hoses and connect the hydraulic hoses in accordance with the labels.
5. Operate paver and check for leaks.

NOTE: When installing motor dry, crank and let run for approx. 10 minutes to work air out of system before engaging to move.

Safety Label Installation

Anytime the LeeBoy Model Legend Electric Screed has been repainted or the safety labels have been removed, damaged or can't be read, a new set of labels should be ordered and reinstalled for safe operation (**Figure 2-1; Figure 2-2**).

1. Be sure that the installation area is clean and dry. Use hot soapy water and dry the area thoroughly before installing decals.
2. Determine the exact position by taking measurements and test fitting before you remove the backing paper.
3. For safety labels with no top protection paper, determine the label location and remove the smallest portion of the split backing paper.
4. Align the label over the specified area and carefully press the small portion with the exposed adhesive backing into place.
5. Peel back the remaining paper and carefully smooth the remaining portion of the label in place.
6. Small air pockets can be pierced with a pin and smoothed out using the piece of label backing paper.
7. If the label has a protective top paper, use hot soapy water on the surface to which the label is being applied. Leave wet. After determining the location, remove the backing paper and soak the label in clean soapy water before application. This will help prevent air bubbles in the finished label.
8. Smooth the label into place with a sponge and check for air bubbles. Small air pockets may be pierced with a pin and smoothed out. When the label is completely smoothed out, carefully remove the top paper.

NOTES



Section 8

TROUBLESHOOTING

	Page
Troubleshooting	8-1
Troubleshooting Charts	8-2

TROUBLESHOOTING CHARTS

The troubleshooting charts below identify the most common symptoms of failure. Use these charts to help identify the failed component and possible remedies.

If the problem persists, see your authorized LeeBoy Dealer (see **Contact Information** in Section 3).

Table 8-1. Electric Screed Troubleshooting

SYMPTOM	CAUSE	REMEDY
Electric Screed heating system will not operate at all.	Control box power switch not in “on” position.	Ensure that the screed control box power switch is “on”.
	Breakers are in a tripped position with no breakers showing a tripped condition.	Ensure all element breakers are in their “set” position with no breakers showing a tripped condition.
	Engine not operating at proper throttle.	Ensure the paver is running. Set the throttle on the paver to full engine RPM. NOTE: Throttle positions less than full will still produce screed heat, but at a drastically reduced rate and temperature.
	Generator malfunction.	See generator voltage testing.
Electric Screed heats, but one screed section does not.	Screed section not plugged into bottom of control box out puts.	Ensure the screed not heating is plugged into the bottom of the control box out puts.
	Element breakers for screed section in a tripped condition.	Ensure the element breakers for that screed section are not tripped.
	Faulty element relay.	See Testing element relays, or Testing element resistance.
When starting the electric heat system, it will not stay running long, or at all.	Heat system timed out.	See Testing system timer.
Electric Screed is heating, but never gets hot enough to pave.	Engine not operating at proper throttle.	Ensure the paver is running. Set the throttle on the paver to full engine RPM. NOTE: Throttle positions less than full will still produce screed heat, but at a drastically reduced rate and temperature.
	Elements improperly clamped.	Go over proper element installation procedures, and ensure elements are clamped properly.
	Generator malfunction.	See Generator speed tuning. See Generator voltage testing.
Electric heating system seems to be working, but the light isn’t on.	“Heat On” light is burned out.	Replace the “Heat On” light.
Elements have been tested but the breaker still trips.	Faulty element wiring.	Test or inspect element wiring.
	Faulty breaker.	Replace defective breaker.

Table 8-2. Paver Troubleshooting

SYMPTOM	CAUSE	REMEDY
Engine does not start	Defective battery or low battery charge	Replace or charge battery as applicable
	Joystick Control not centered (neutral)	Center steering control and activate neutral switch
	Insufficient fuel supply	Fill fuel tank
	Fault in engine	Refer to engine operator's manual
	Safety switch faulty	Replace
	Wires not making good connection on solenoid	Make sure wires are tight
	Plug in switch box unplugged	Plug back in
	Solenoid plunger sticking	Clean plunger
	Starter or solenoid faulty	Replace or rebuild
	Neutral switch defective	Replace
Engine stops or turns over but will not start	Low fuel	Add fuel to fuel tank
Low Battery	Faulty alternator	Replace or rebuild
Machine will not move	Electrical cord Faulty	Check electrical cord.
Machine will not run straight	One of the hydraulic drive motors is out of adjustment	Readjust motors
	Steering control not centered	Center steering control
	Travel pump defective	Replace pump or rebuild
	Steering out of adjustment	Calibrate (PLUS ONE)
Machine does not change speed when 2-SPEED HIGH/LOW SWITCH is toggled	Defective switch	Replace switch
	Defective solenoid	Replace solenoid
	Defective drive motor	Replace drive motor
Tracks not running smooth	Too low engine rpm to hold track tension	Rev engine to full RPM and throttle back to one-half
	Track rollers worn	Replace
	Track tension pressure	Check pressure. NOTE: Pressure should be set to 700 PSI
Machine will not pull on one or both sides	Faulty hydraulic motor	Adjust
	Pump pressure too low	Pump pressure should be 3000 PSI
	Faulty torque hub	Rebuild or replace
Engine runs but no hydraulics	Engine rpm too low	Increase engine speed
	Pump drive coupling faulty	Replace
	Defective pump	Replace
Auger hanging up or will not turn	Chain too loose	Adjust
	Chain broke	Replace
	Faulty motor	Replace
	Solenoid valve defective	Replace solenoid
	Asphalt set up around auger	Keep clean and oiled

Table 8-2. Paver Troubleshooting (continued)

SYMPTOM	CAUSE	REMEDY
Screed extensions binding	Asphalt set up around extension	Keep clean and oiled
Screed extension loose (work up and down)	Out of adjustment	Adjust hold downs on extensions
Screed leaving streak down center of pavement	No lead crown in screed	Crown leading edge of screed
	Screed worn out	Replace
	Extensions set too low	Adjust extension. Always start out in the morning with extensions all the way up, no down pressure
	Screed not heated properly	Set propane pressure at 15 PSI for about 5 to 8 minutes
Screed leaving ripples	Extension set too low	Readjust extensions
	Extensions work up and down	Adjust top guide
	Extension rod bushings worn	Replace bushings
Flight screw locking up	Twisting screed too far	Give screed time to react
	Screw seized	Replace screw
Flight screw bearing damage	Twisting screed too far	Give screed time to react
	Loading and unloading	Check ramps for easy access
Flame coming out of end of screed	Raw gas from burners	Adjust burners in or out of hole
		Turn cutoff valve slowly to OFF, when flame goes out turn valve back on fully
Hydraulic oil running out of breather cap	Hydraulic oil tank overfilled	Drain 5 to 6 in. (12.7 to 15 cm) from top of tank
	Air in bottom of tank	Bleed if you don't have vent hose
	Oil over heated	Slow paver down about 10% to 15% Check oil cooler and thermostat
Hydraulic pump cavitating or lost power	Low level in hydraulic tank	Fill
	Clogged filters	Replace
	Suction hose loose	Retighten
	Charge pump worn	Rebuild
Feeder does not work on one or both sides	Defective AUTOMATIC/MANUAL switch	Replace switch
	Solenoid defective	Replace solenoid
	Feeder drive chain broken	Repair chain
	Defective conveyor motor	Replace motor
	Rear conveyor shaft broken	Replace conveyor shaft
Feeder flight bars hang up	Flight chains too loose	Adjust. If adjusted all the way and a link is removed you must install a 1/2 link
	Feeder drive chain too loose	Adjust every 100 hours
Loss of power to drives feeder or augers	Relief out of adjustment	Check pressure. Drive - 3000 PSI, feeders 2400 PSI, augers and cylinders 2000 PSI
	Piston groups worn out	Replace
	Auxiliary pump worn out	Replace



Section 9

SCHEMATICS

	Page
Schematics	9-1
Electrical 1 of 4	9-3
Electrical 2 of 4	9-5
Electrical 3 of 4	9-7
Electrical 4 of 4	9-9
Hydraulic 1 of 5	9-11
Hydraulic 2 of 5	9-13
Hydraulic 3 of 5	9-15
Hydraulic 4 of 5	9-17
Hydraulic 5 of 5	9-19

NOTES

Electrical 1 of 4

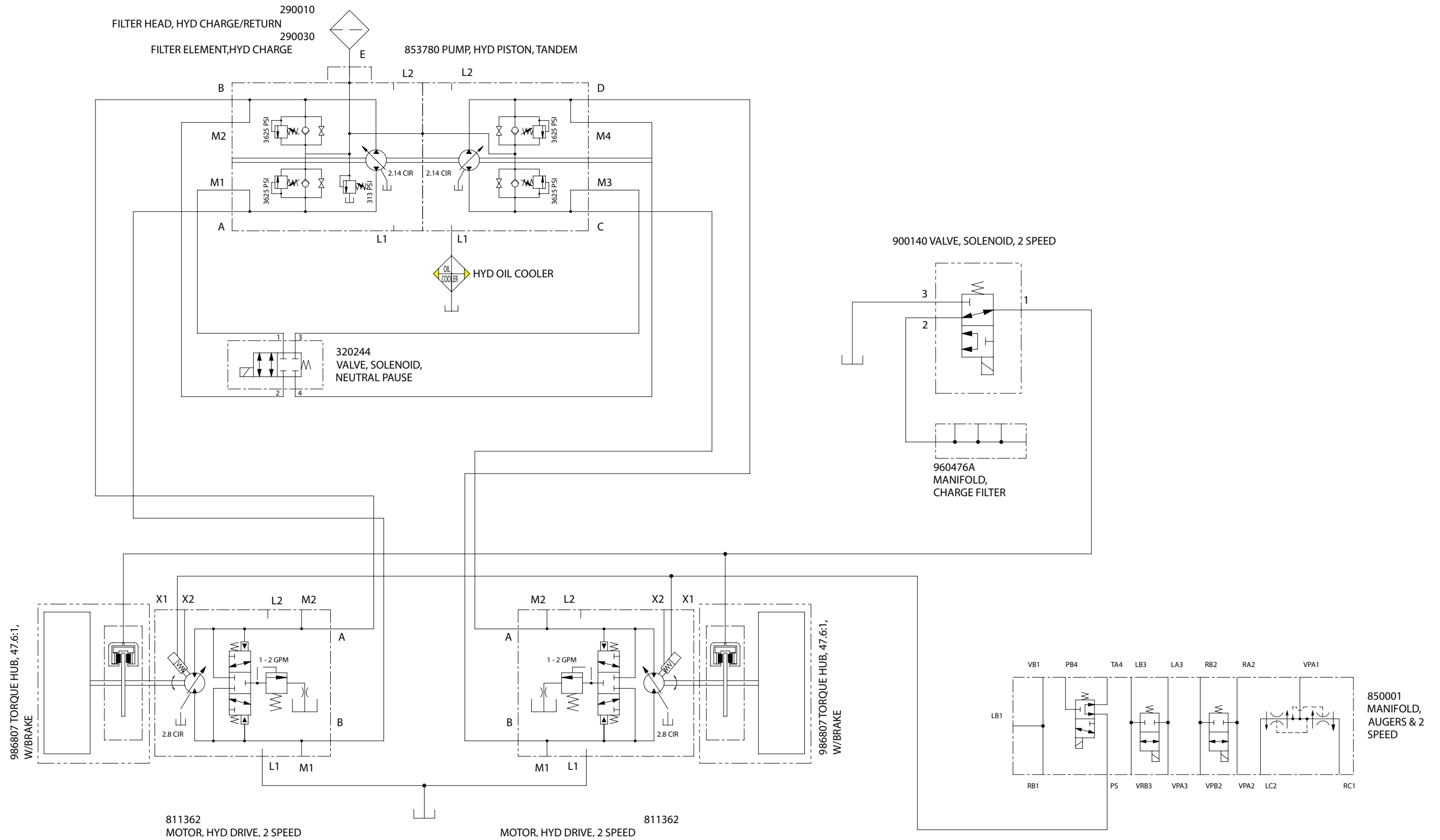

Figure 9-1

NOTES

Electrical 2 of 4

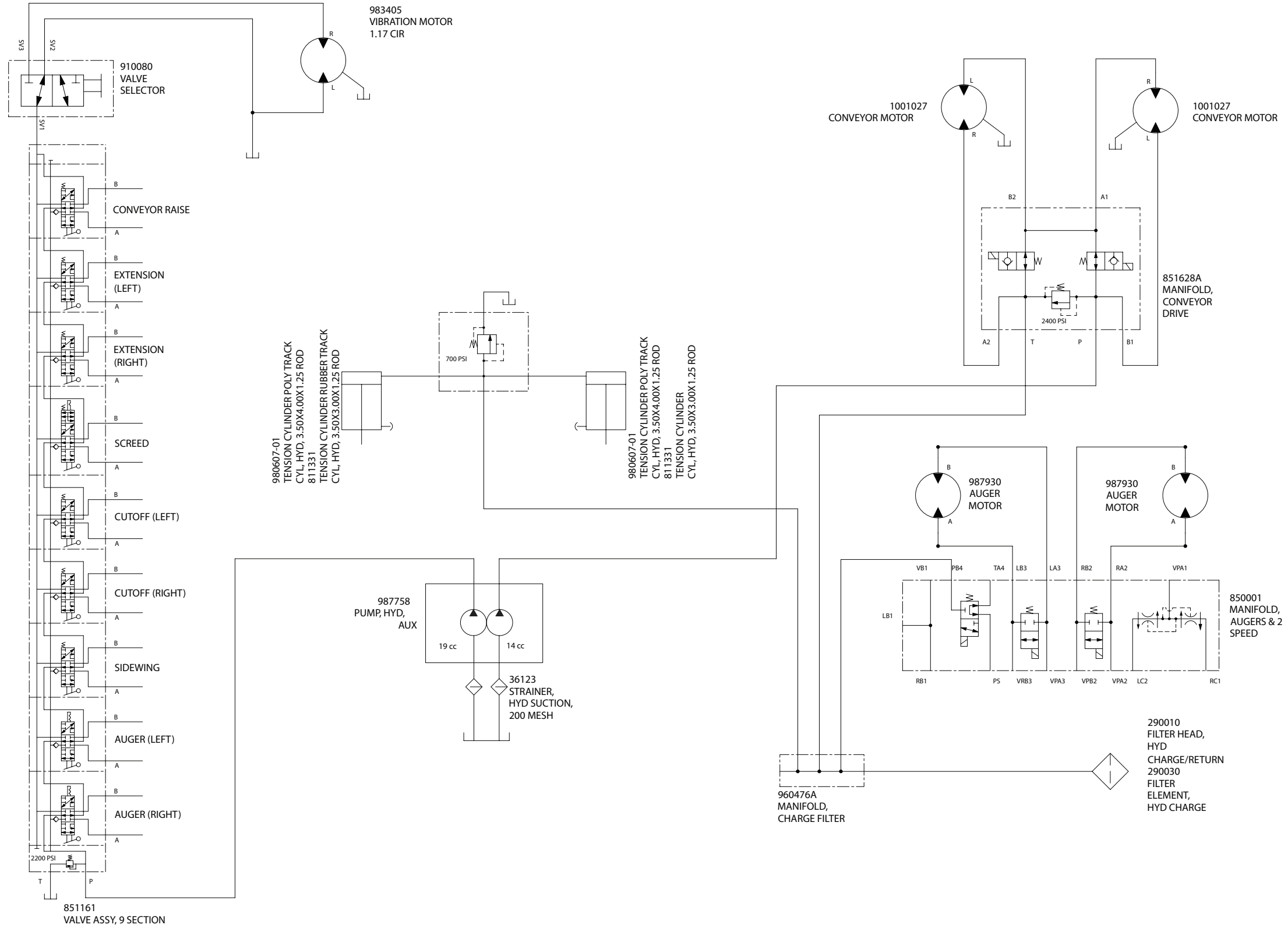
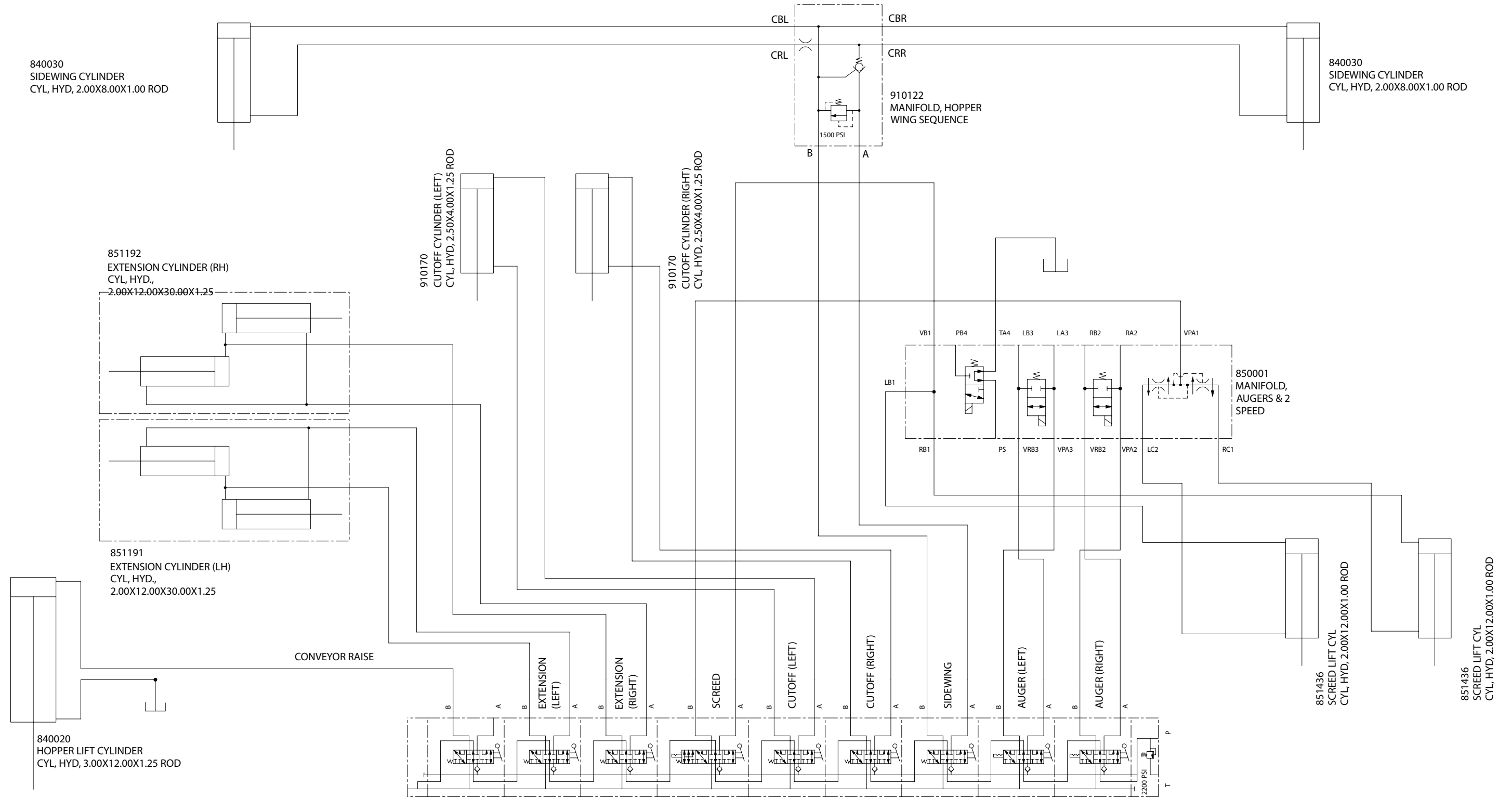

Figure 9-2

NOTES

Electrical 3 of 4



851161 VALVE ASSY, 9 SECTION

Figure 9-3

NOTES

Electrical 4 of 4

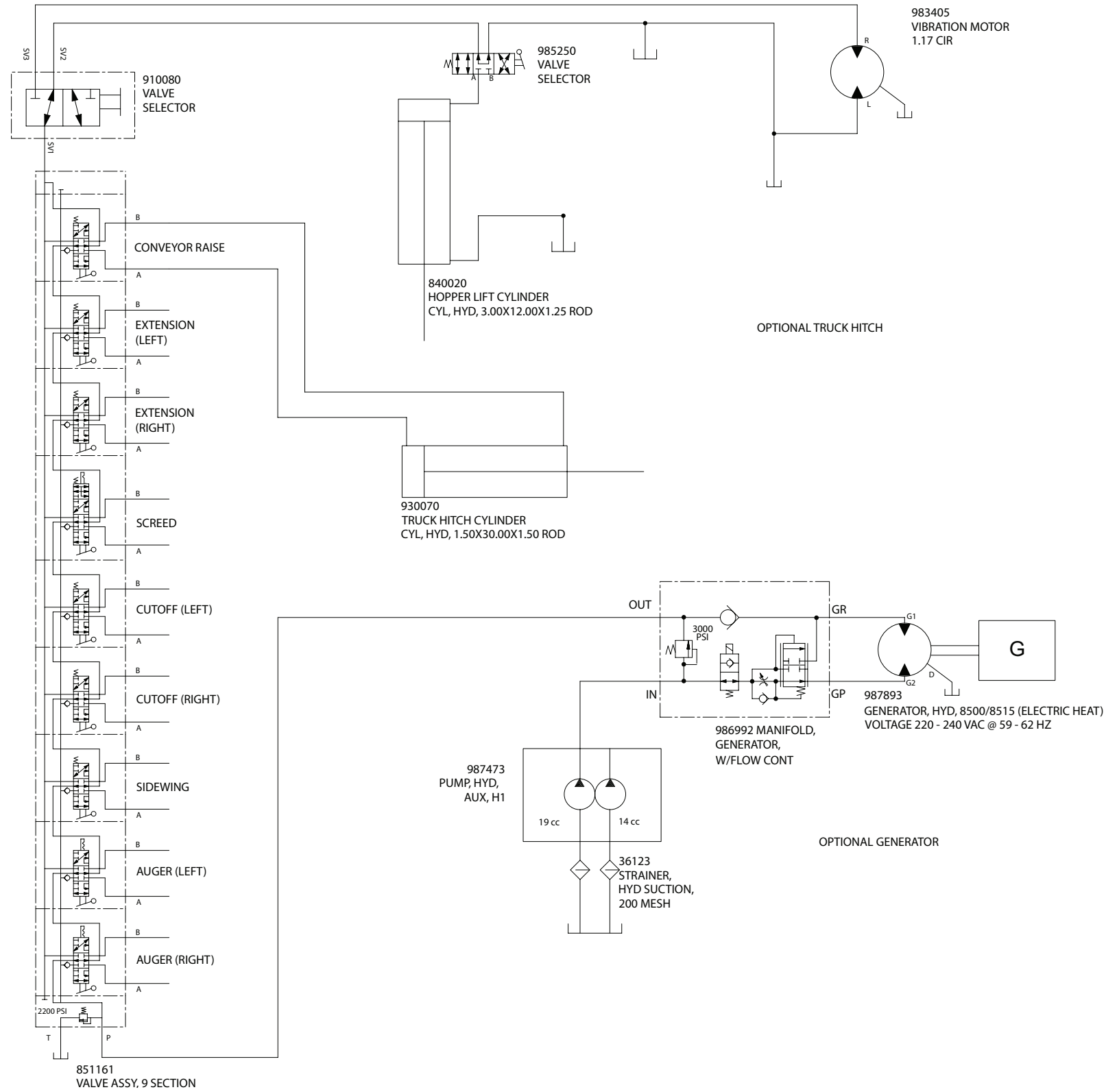

Figure 9-4

NOTES

Hydraulic 1 of 5

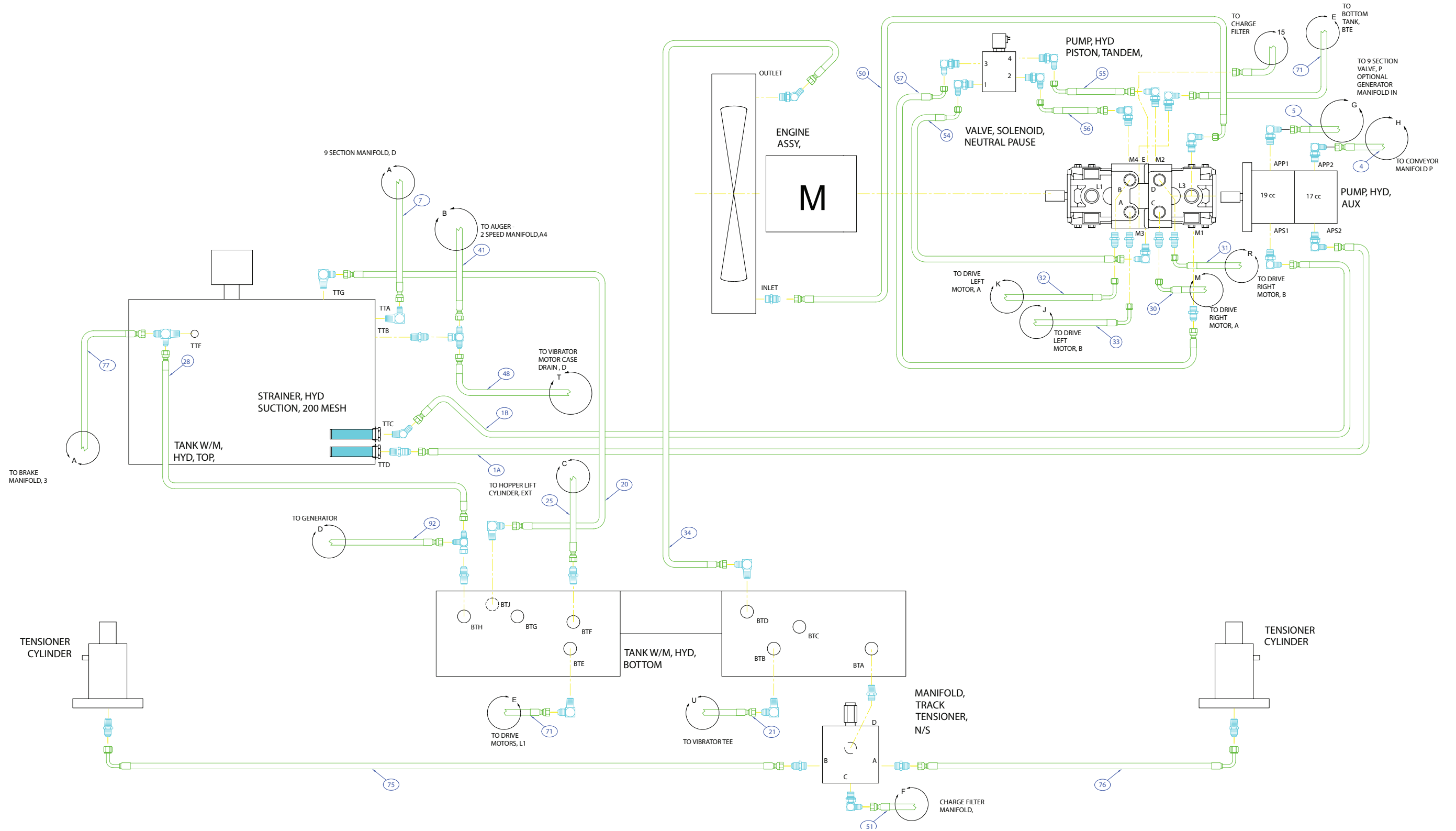

Figure 9-5

NOTES

Hydraulic 2 of 5

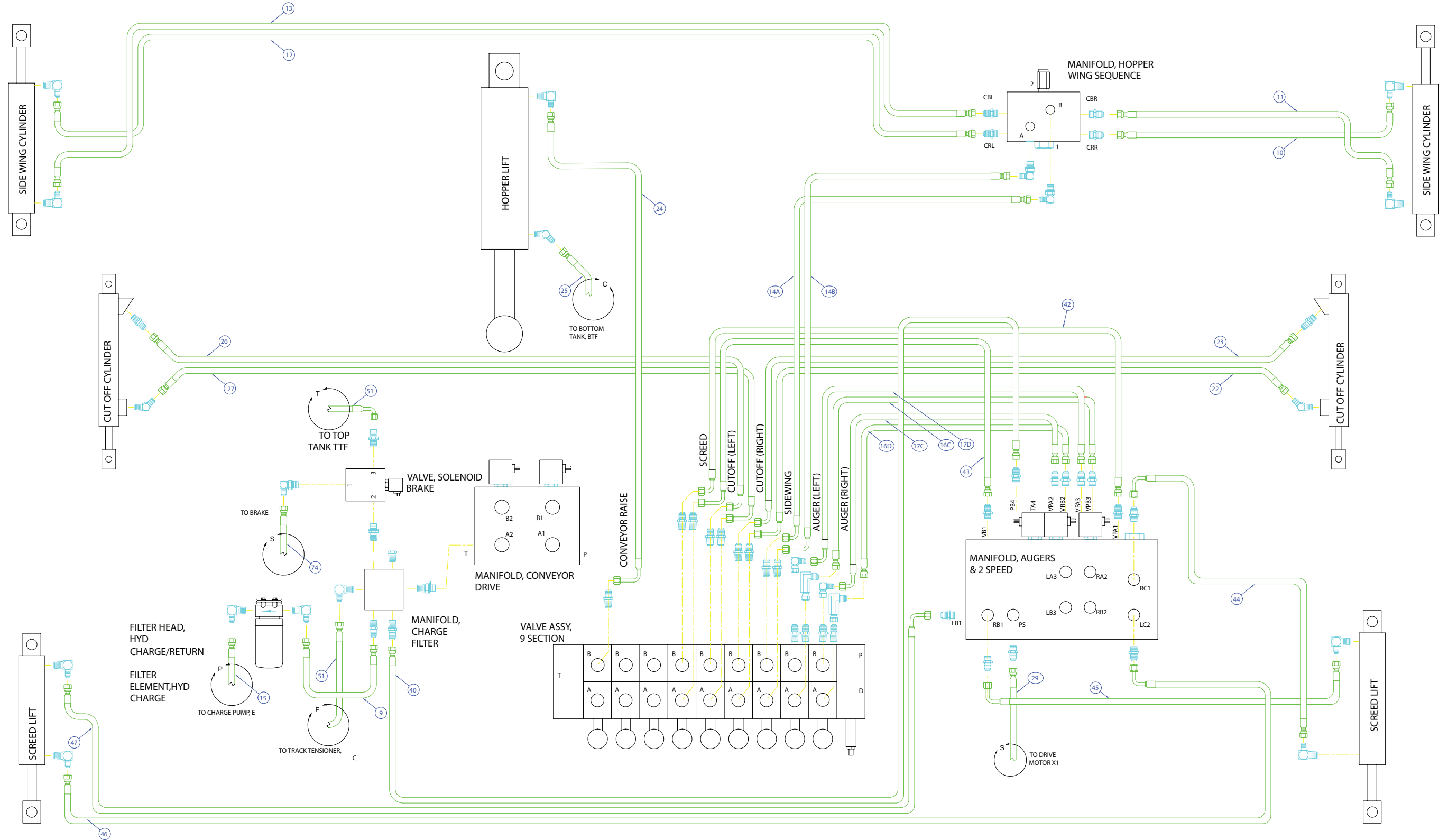

Figure 9-6

NOTES

Hydraulic 3 of 5

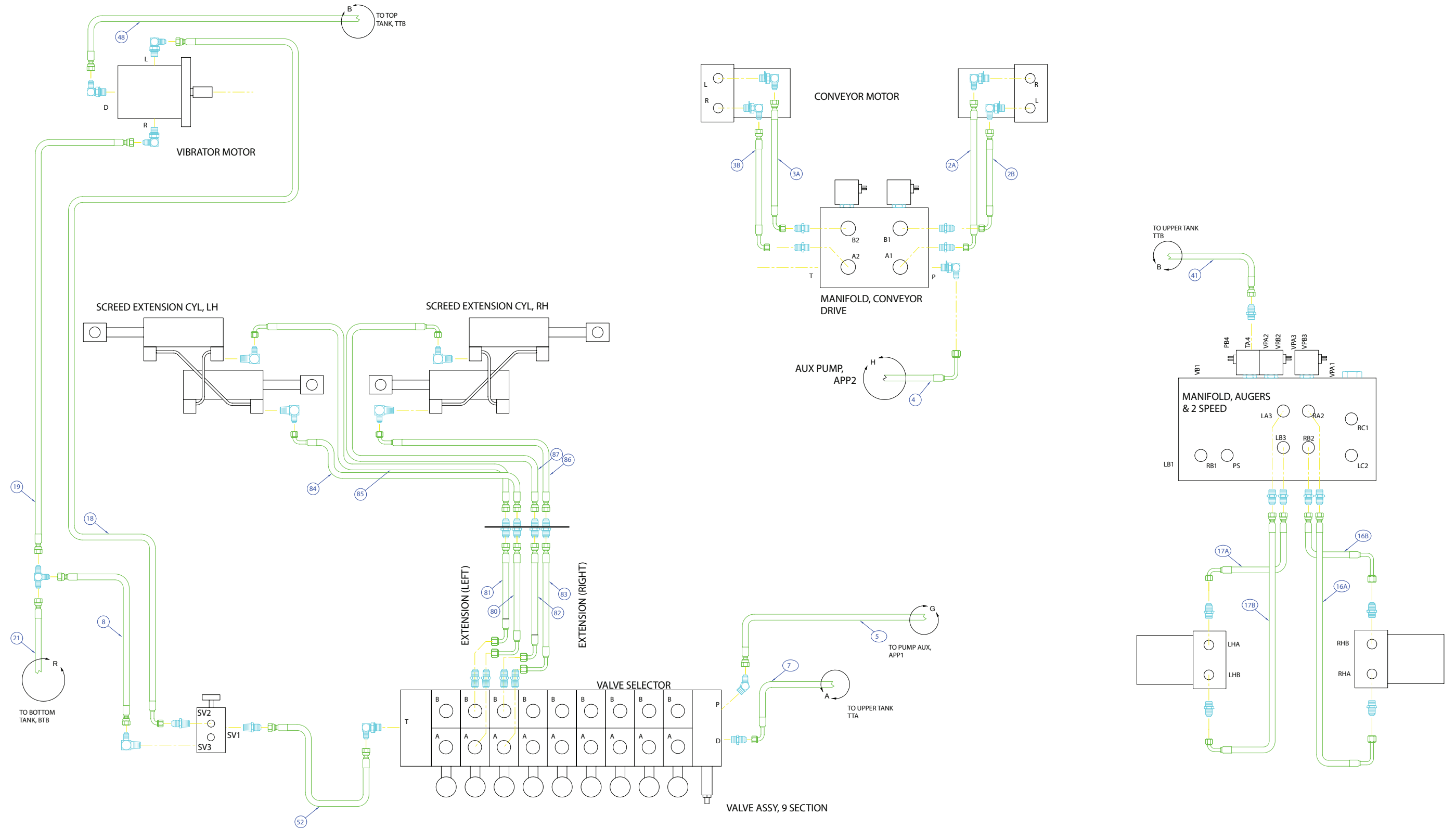
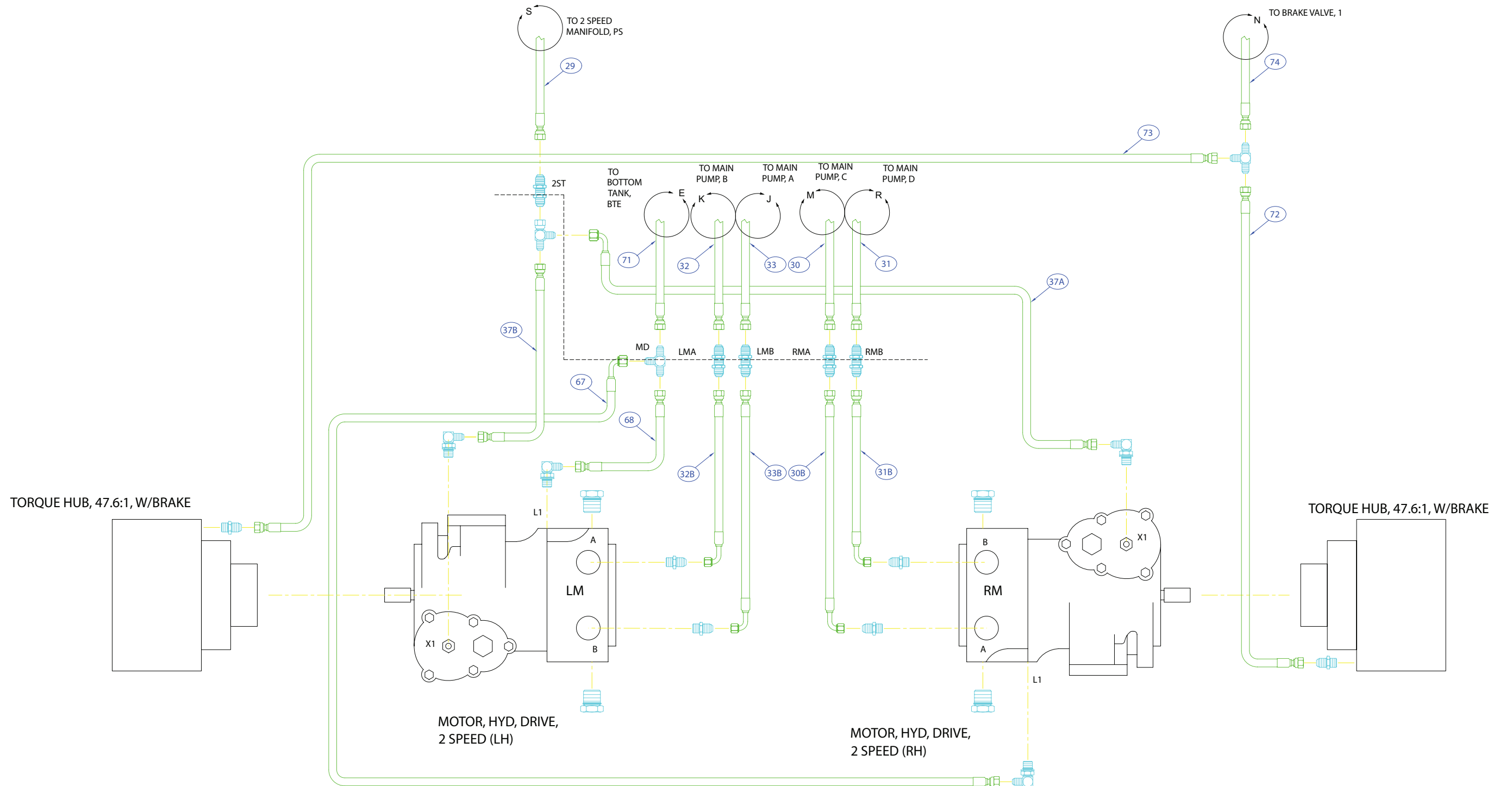

Figure 9-7

NOTES

Hydraulic 4 of 5



VIEW IS FROM BACK OF MACHINE

Figure 9-8

NOTES

Hydraulic 5 of 5

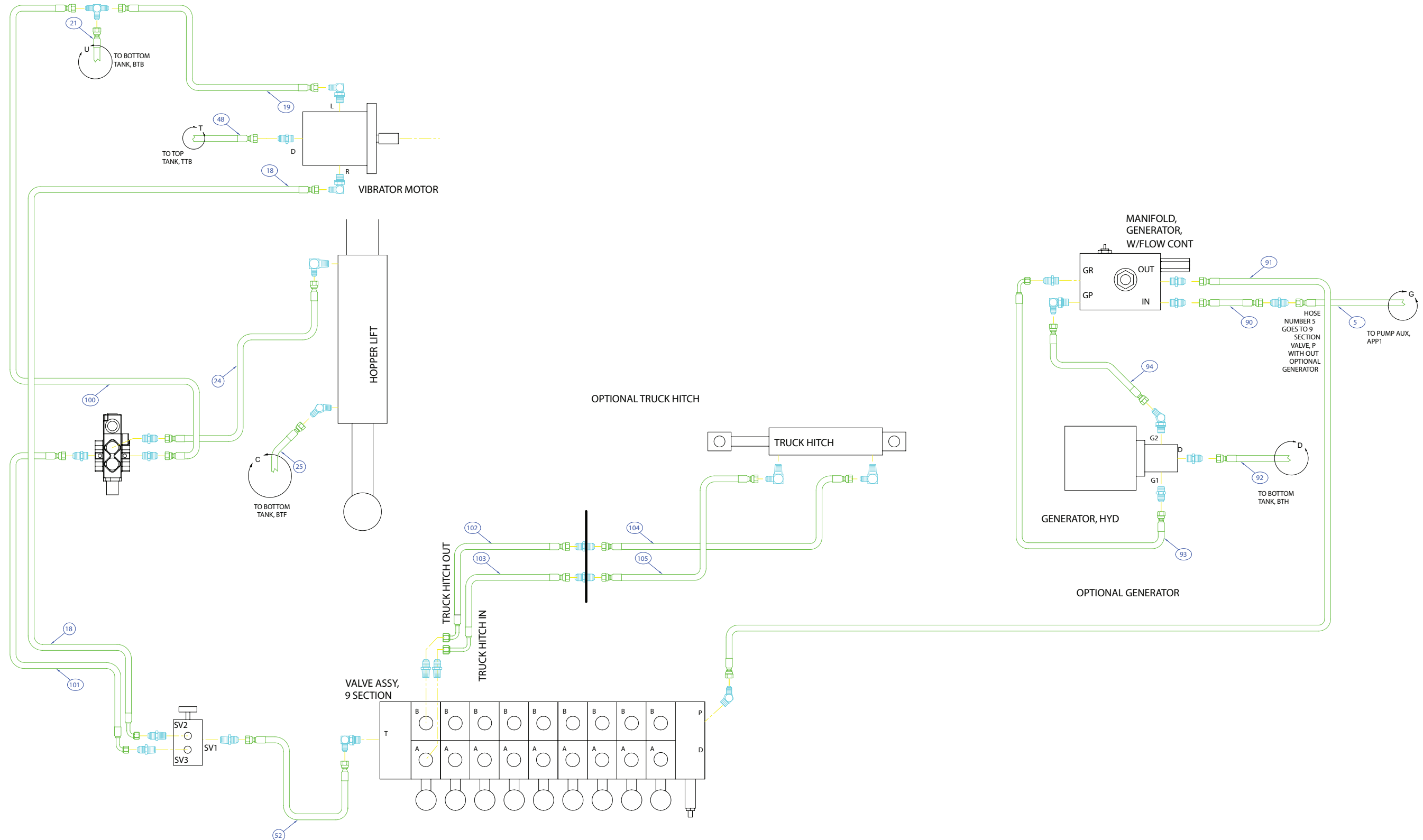

Figure 9-9

NOTES



Section 10

ILLUSTRATED PARTS LIST (IPL)

	Page
Illustrated Parts List (IPL)	10-1
Quick Reference Guide - Filters	10-3
Sprocket Drive Track System (4 Roller Undercarriage)	10-4
Sprocket Drive Track System (4 Roller Undercarriage) (continued).	10-6
Rubber Track Undercarriage (5 Roller Undercarriage)	10-8
Conveyor Drive Assembly	10-10
Conveyor Drive Assembly (continued)	10-12
Hopper Components	10-14
Hopper Components	10-16
Auger Assembly	10-18
Conveyor Drive Cutoff, Screed Lift Cylinders	10-20
Hydraulic Components LH Side Fuel Tank	10-22
Kubota Engine	10-24
Kubota Engine (continued).	10-26
Kubota Engine (continued).	10-28
Cat Engine.	10-30
Cat Engine (continued).	10-32
Cat Engine (continued).	10-34
Pump Components	10-36
Main Valve And Spray Down (Option).	10-38
Screed Arm Assembly With Manual or Electric Toe Point	10-40
Propane Heater And Automatic Ignitors	10-42
Auger Extension	10-44
Paver Leveling Control (TOPCON) System 4	10-46
Paver Leveling Control (TOPCON) System 5	10-48
Truck Hitch Assembly	10-50
Controls - Right Side High Deck	10-52

Controls - Right Side Low Deck10-54
Controls - Left Side10-56
Controls - Left Side (continued)10-58
Main Valve Manifold Detail	10-60
Kubota Sheet Metal Cover - High Deck.10-62
Kubota Sheet Metal Cover - High Deck (continued).10-64
Kubota Sheet Metal Cover - Low Deck	10-66
Kubota Sheet Metal Cover - Low Deck (continued)	10-68
CAT Sheet Metal Cover - High Deck10-70
CAT Sheet Metal Cover - High Deck (continued)10-72
CAT Sheet Metal Cover - Low Deck10-74
CAT Sheet Metal Cover - Low Deck (continued)10-76
Strike Offs And Extensions.10-78
Instrument Panel Dash - Controls and Gauges	10-80
Instrument Panel Dash - Relays and Fuses.10-82
Screed Non-sloping Overview10-84
Screed Frame Non-Sloping - Propane	10-86
Extension Single Adjust LH Assembly - Propane	10-88
Extension Single Adjust RH Assembly - Propane	10-90
Extension Double Adjust LH Assembly - Propane.10-92
Extension Double Adjust RH Assembly - Propane10-94
Screed Frame Non-Sloping - Electric	10-96
Vibrator Assembly	10-98
Walk Board Assembly	10-100
Slide Plate Assembly.	10-102
Extension Single Adjust LH Assembly - Electric.	10-104
Extension Single Adjust RH Assembly - Electric	10-106
Extension Double Adjust LH Assembly - Electric	10-108
Extension Double Adjust RH Assembly - Electric	10-110
Endgate LH Assembly	10-112
Endgate RH Assembly	10-114
Screed Pull Arms LH Assembly	10-116
Screed Pull Arms RH Assembly	10-118
Citrus Tank & Heat Control Box	10-120
Screed Miscellaneous Components	10-122
Generator	10-124
Alphabetical Parts Index	10-126

Quick Reference Guide - Filters

Part Number	Description	Maint. Interval	Figure Ref.
982080-02	Kubota, Fuel Filter	250 Hours	Figure 10-8
986537-03	Kubota, Oil Filter	250 Hours	Figure 10-8
986537-31	Kubota, In-line Filter	250 Hours	Figure 10-8
38385-01	Kubota, Air Primary Filter	250 Hours	Figure 10-8
38385-02	Kubota, Air Safety Filter	250 Hours	Figure 10-8
984909-01	CAT, Fuel Filter	250 Hours	Figure 10-9
988671-04	CAT, Oil Filter	250 Hours	Figure 10-9
38385-01	CAT, Air Primary Filter	250 Hours	Figure 10-9
38385-02	CAT, Air Safety Filter	250 Hours	Figure 10-9
36123	Hydraulic, Filter - 2 Required	250 Hours	Figure 10-7
290030	Hydraulic, Charge Filter Return	250 Hours	Figure 10-7
984594-01	Hydraulic, Element	250 Hours	Figure 10-7
36926	Spray Down Pump, Strainer	250 Hours	Figure 10-11

Sprocket Drive Track System (4 Roller Undercarriage) Parts List

Item No.	Part Number	Qty.	Description	Remarks
2	851101P	1	Track Assy, One Side, w/Poly Pads	
3	851102	1	Chain Rail, Track Drive	
4	986807	1	Torque Hub, 47.6:1, w/Brake	
5	1003052	1	Sprocket, Track Drive	
6	81201	7	Washer, Flat, SAE, .625	
7	80983	7	CSHH, .625-11 x 2.00 GR8	
8	81170	12	CSHH, .625-11 x 1.25 GR8	
9	851566	1	Track Roller, B/1	
10	811328	20	Washer, Lock, M12	
11	811330A	8	CSHH, M12-1.50 x 50mm	
12	811326	3	Track Roller, B/O	
13	811330	12	CSHH, M12-1.50 x 40mm	
14	1001589	1	Idler, Track Front	
15	1003072	1	Assy, Weldment, Undercarriage, L.H.	
16	1003073	1	Assy, Weldment, Undercarriage, R.H.	
17	811329A	1	Yoke, Track Idler	
18	870307	1	Hair Pin Cotter, .177	
19	811331	1	Cyl, Hyd, Track Tensioner	
20	851644	1	Breather, Track Tensioner Cyl.	
21	811331-01	1	Seal Kit, Hyd. Cyl.	
22	851104	A/R	Track Pad, Poly	
22a	811304	A/R	Cast Track Pad	33 per side
–	851101	A/R	Track Assy, Cast	Not Shown
24	811312	A/R	Link Kit, Track Repair	
25	851460	A/R	Bushing, Track Link, Short	
26	811314	A/R	Bushing, Track	
27	811307	A/R	Pin, Track Link, Plain	
28	811306	A/R	Pin, Track Link, Master	
29	811310	A/R	Spacer, Track Link Bushing	
30	811308	A/R	CSHH, Track Pad	
31	811309	A/R	Nut, Track Pad Cap Screw	
32	2404-10-8	1	Adapter, Hyd. Hose	
33	984283SRV	1	Push Roller Assy, Swivel	
34	850130	4	Bearing, Auger, Axle, Idler	
35	980032	2	Roller Assy, Push Bar, w/Brgs and Shaft	
36	980034	2	Shaft, Push Bar Roller	
37	810070	2	Bushing, 2.00 ID x 2.50 OD x 2.50	
38	810081SRV	1	Pin, Push Bar Swivel	

Sprocket Drive Track System (4 Roller Undercarriage) (continued)

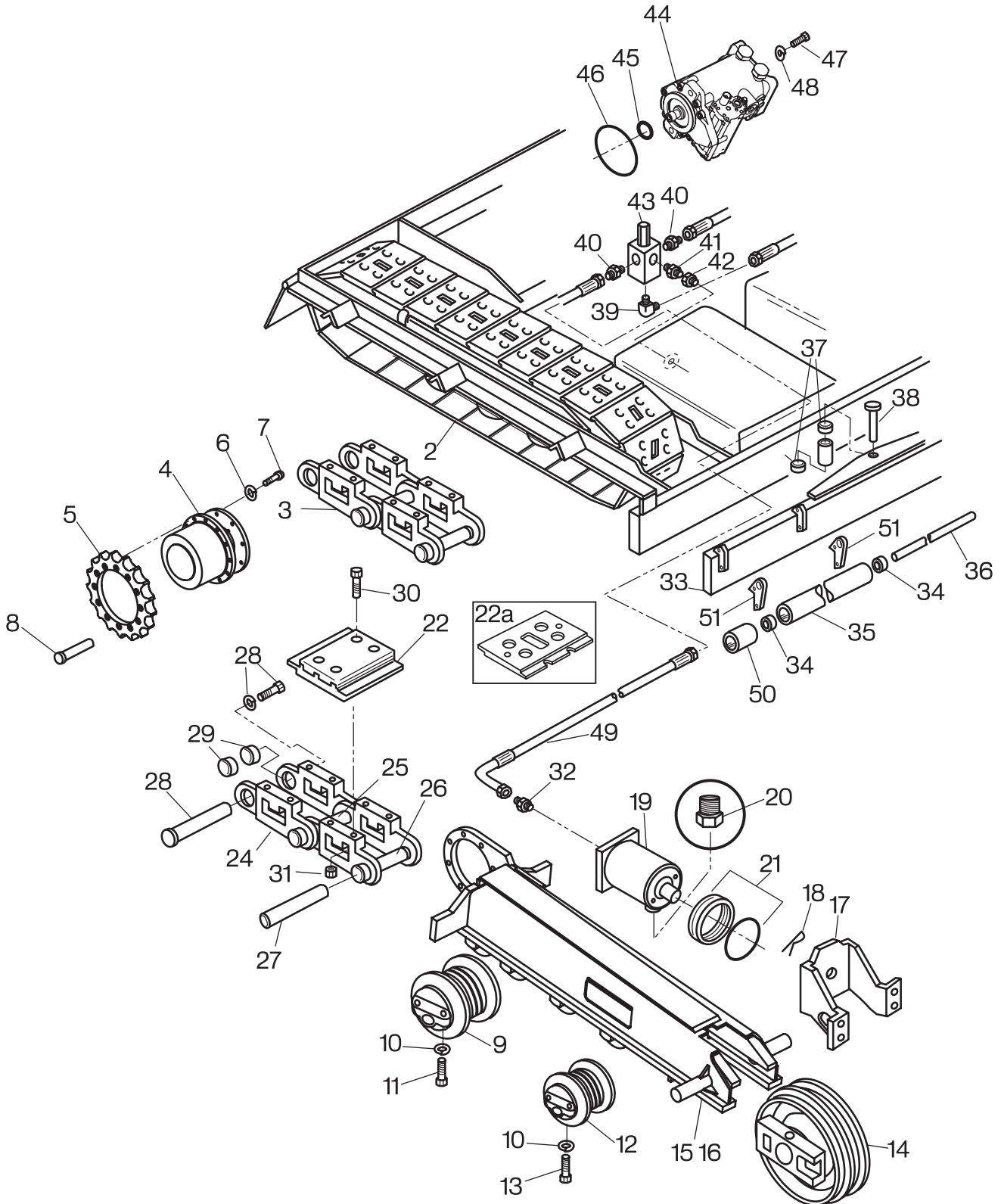

Figure 10-1

Sprocket Drive Track System (4 Roller Undercarriage) Parts List (continued)

Item No.	Part Number	Qty.	Description	Remarks
39	6801-10-8	1	FITT, 90 10MJ-08MB	
40	6400-10-8	1	FITT, Str 10MJ-08MB	
41	6401-8-8	1	FITT, Str 08MP-08MB	
42	5406-12-8	1	FITT	
43	851544	1	Manifold, Track Tensioner	
44	811362	1	Motor, Hyd, Drive, 2 Speed	
45	851489A	A/R	Seal, Hyd Motor/Pump	
46	811366	A/R	O-Ring, Hyd. Motor	
47	811364	2	CSHH, .500-13 x 1.50	
48	118-5	2	Washer, Lock, .500	
49	8550B	1	Hose Assy Track RH Tensioner	
50	980035	2	Roller, Extension Bumper	
51	852664	2	Extension, Front Bumper	

Rubber Track Undercarriage (5 Roller Undercarriage)

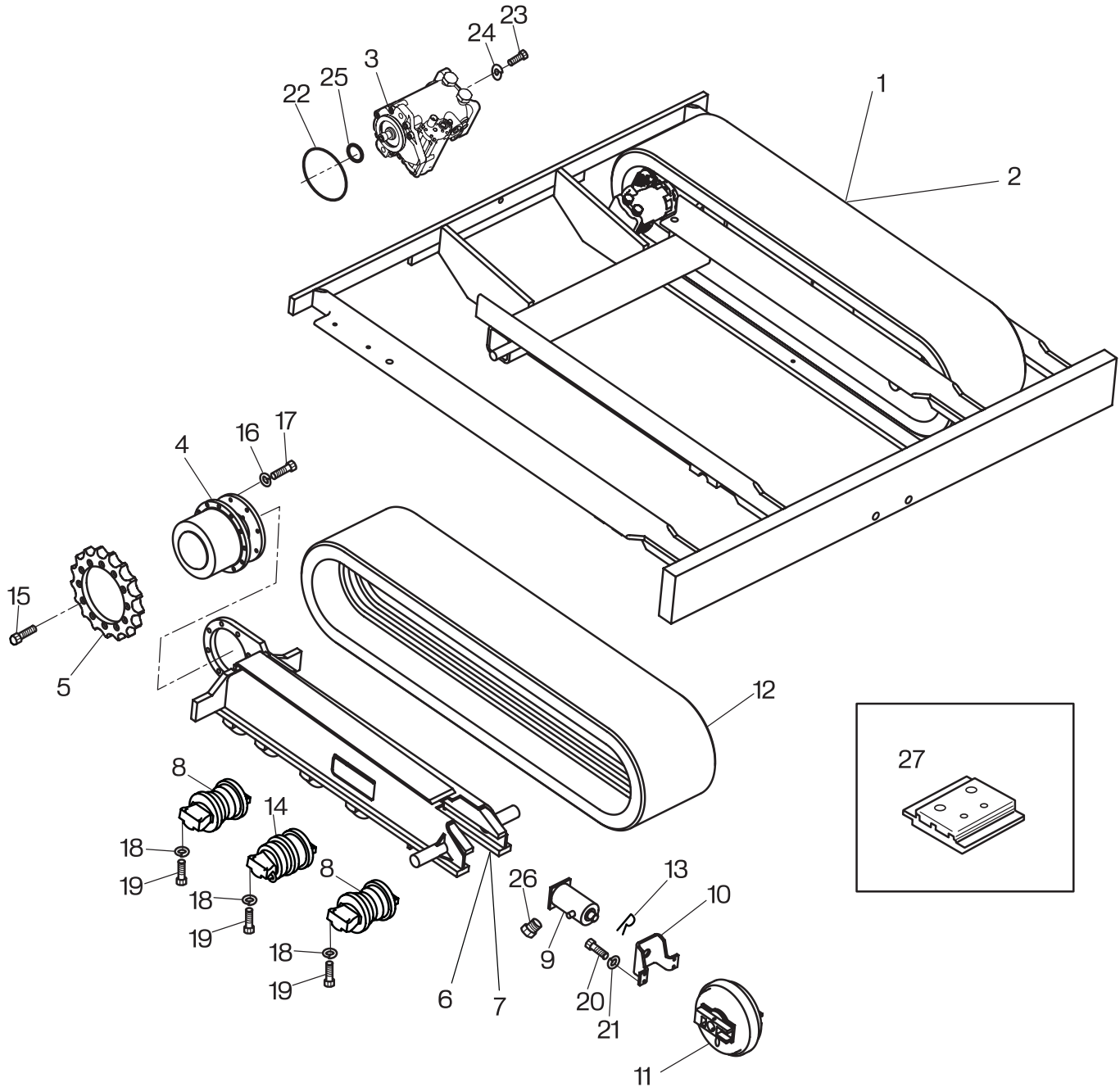

Figure 10-2

Rubber Track Undercarriage (5 Roller Undercarriage) Parts List

Item No.	Part Number	Qty.	Description	Remarks
1	980607L	1	Undercarriage Complete, Rubber, LH	
2	980607R	1	Undercarriage Complete, Rubber, RH	
3	811362	1	Motor, Hyd, Drive, 2 Speed	
4	986807	1	Torque Hub, 47.6:1, w/Brake	
5	980670	1	Sprocket, Track Drive, 17 Tooth	Rubber Track Only
6	980606R	1	Weldment Undercarriage, Rubber Track, RH	Rubber Track Only
7	980606L	1	Weldment Undercarriage, Rubber Track, LH	Rubber Track Only
8	851566	2	Track Roller, B/1	Rubber Track Only
9	980607-01	2	Cyl, Hyd, Track Tensioner	Rubber Track Only
–	980607-02	A/R	Seal Kit	Not Shown
10	811329A	2	Yoke, Track Idler	
11	983530	2	Idler, Track Front	Rubber Track Only
12	982585	2	Track, Rubber, Continuous	
13	870307	2	Hair Pin Cotter, .177	
14	983588	3	Track Roller, B-1, Inner Flange	Rubber Track Only
15	81170	12	CSHH, .625-11 x 1.25 GR8	
16	81201	7	Washer, Flat, SAE, .625	
17	80983	7	CSHH, .625-11 x 2.00 GR8	
18	811328	20	Washer, Lock, M12	
19	811330A	12	CSHH, M12-1.50 x 50mm	
20	989272-36	4	CSHH, M10-1.50 x 30mm	
21	320142	4	Washer, Lock, M10	
22	811366	A/R	O-Ring, Hyd. Motor	
23	80503	2	CSSH, .500-13 x 1.75	
24	118-5	2	Washer, Lock, .500	
25	851489A	A/R	Seal, Hyd Motor/Pump	
26	851644	1	Breather, Track Tensioner Cyl.	
–	983166	A/R	Track Assy, One Side	30 Pads per side
27	983166-02	A/R	Track Pad, Poly, Heavy Duty	
–	983166-03	A/R	Link, Only H/D 135mm Chain	Not Shown
–	983166-04	A/R	Pin, Track Link, Master, Heavy Duty	Not Shown
–	983166-05	A/R	Nut, Hex, Track Pad	Not Shown
–	983166-06	A/R	CSHH, 135mm, Track Pad Bolt	Not Shown

Conveyor Drive Assembly

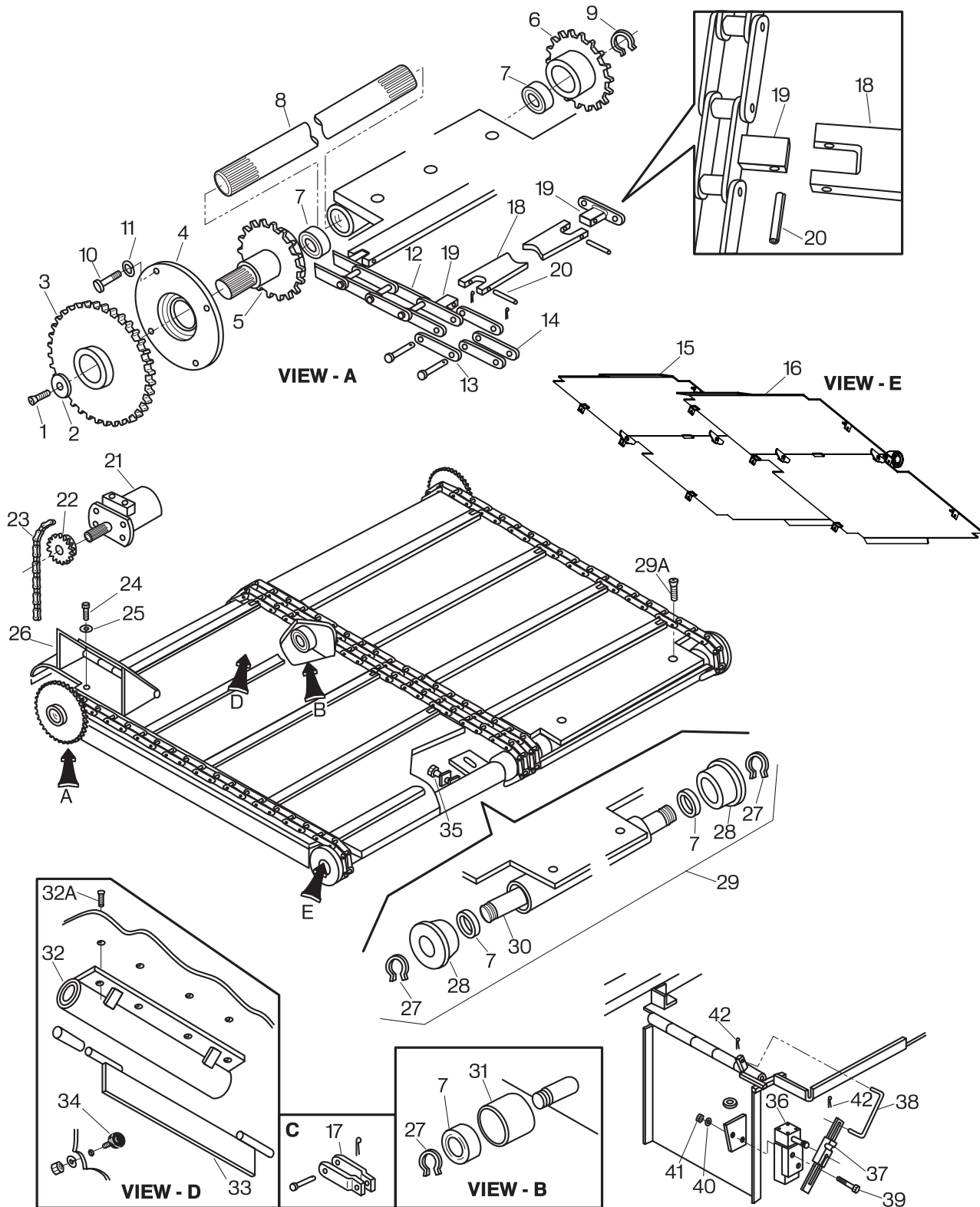

Figure 10-3

Conveyor Drive Assembly Parts List

Item No.	Part Number	Qty.	Description	Remarks
–	851626SRV	1	Conveyor, Assy. Complete	Not Shown
–	851627SRV	1	Bed Assy, Conveyor	Not Shown
1	851111	2	CSHH, .500-13 x 2.00	
2	851112	2	Washer, Counter Sunk, .500	
3	851473	2	Sprocket, Outer Drive	
4	851483	2	Conveyor Mounting Plate With Bearing	
5	851474SRV	2	Sprocket, Outer Dr. C-188	
6	850030	2	Sprocket, Inner Drive C-188	
7	850130	20	Bearing, Auger, Axle, Idler	
8	851116	2	Drive Shaft, Conveyor	
9	850040	2	Snap Ring, Conveyor Drive Shaft	
10	102-405-1A	A/R	CSHH, .500-13 x 1.00	
11	118-5	2	Washer, Lock, .500	
12	851117ASRV	A/R	Conveyor Chain, Assy	
13	850070A	4	Link, Master w/Pins	
14	850080A	A/R	Block Link	
15	851127LSRV	A/R	Belly Pan, LH	
16	851127RSRV	A/R	Belly Pan, RH	
17	850215A	A/R	Half Link, Conveyor Chain w/Pin, Cotter	
18	851118A	A/R	Bar, Conveyor Flight Bar (Quick Change)	
19	850080B	A/R	Link w/Tab Conveyor Chain Inner	
–	851118-2	A/R	Tab, Conveyor Chain Weld On	Replacement, Not Shown
20	851118-1	2	Pin, Roll Pin (.375 x 2.00)	
21	1001027	2	Hyd. Motor, Conveyor Main	
–	1001027-01	A/R	Seal Kit, Hyd. Motor	Not Shown
22	851120	2	Sprocket, Conveyor Drive Motor	
23	851121	2	Chain, Conveyor Drive (#80)	
24	800282	A/R	CSHH, .625 x 1.25	
25	118-7	A/R	Washer, Lock, .625	
26	850038LSRV	A/R	Deflector, Left Side (High Deck)	
–	850038RSRV	4	Deflector, Right Side (High Deck)	Not Shown
27	850040	4	Snap Ring, Conveyor Drive Shaft	
28	850120	4	Idler, Conveyor Chain Front	
29	851123	2	Tube Assy. Conveyor Front Chain Guide	
29A	851653	4	CSSH, .625 x 2.00	
30	851124	2	Shaft, Conveyor Front Idler	
31	850162	4	Roller, Conveyor Chain Guide, w/ Bearing	
32	851651	2	Tube Assy, Conveyor Rear Drive	

Conveyor Drive Assembly (continued)

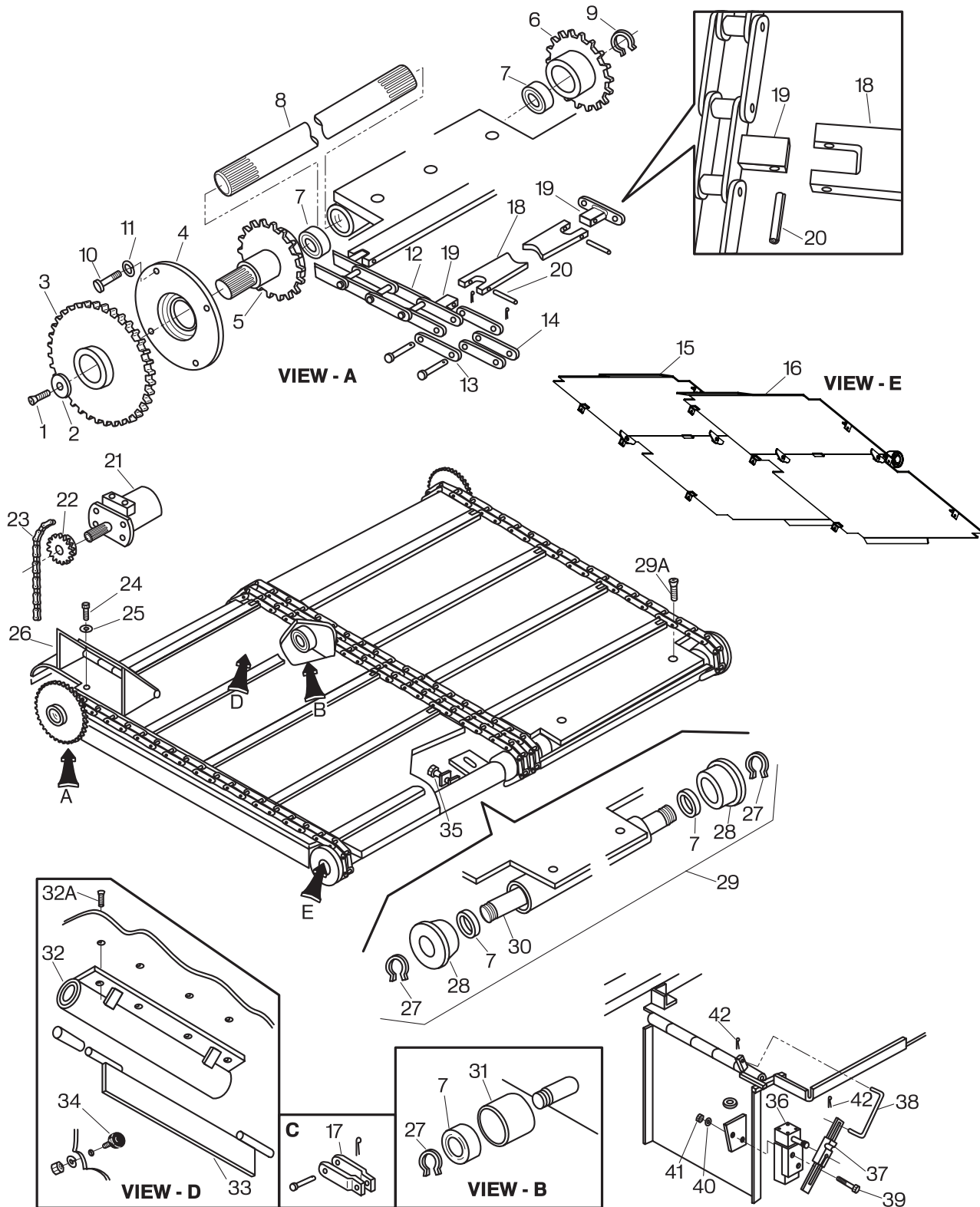

Figure 10-3

Conveyor Drive Assembly Parts List (continued)

Item No.	Part Number	Qty.	Description	Remarks
32A	851652	8	CSSH, .625 x 1.00	
33	851128SRV	2	Scraper, Conveyor	
34	410070	2	Stop Rubber, (Scraper)	
35	850170	4	Set Screw	
—	855921	1	Bar, .500 x 1.50 x 2.50 Hole	Not Shown
36	900050	2	Micro Switch, Auto. Conveyors	
37	900060	2	Arm, Auto. Conveyor Switch	
38	900075	2	Linkage	
39	900076	2	Screws	
40	900077	2	Washer, Lock	
41	900078	2	Nut	
42	900079	2	Pin, Cotter (.250)	

Hopper Components

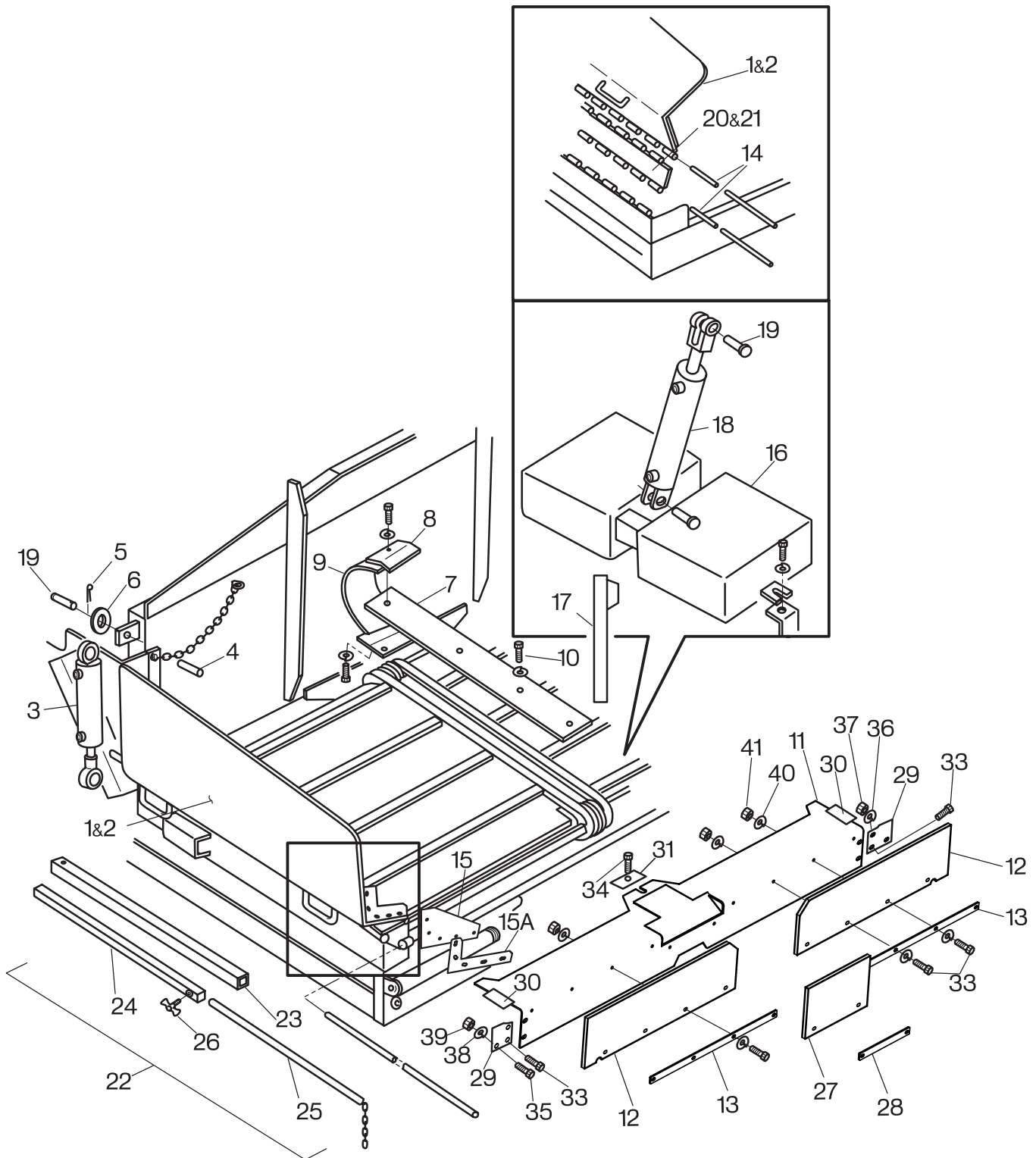

Figure 10-4

Hopper Components Parts List

Item No.	Part Number	Qty.	Description	Remarks
1	851145SRV	1	Hopper Wing Assy, RH	
2	851146SRV	1	Hopper Wing Assy, LH	
3	840030	2	Cyl. Hyd. 2.00 x 8.00	
—	851484	A/R	Seal Kit Universal For 2.00 Cylinder	Not Shown
—	930041	A/R	Side Wing Cylinder Bushing	Not Shown
4	851132	2	Pin	
5	870307	4	Hair Pin Cotter, .177	
6	119-10	2	Washer, Flat, SAE, 1.00	
7	851133	1	Shield, 8500 Center Conv.	
8	802112SRV	1	Hold Down	
9	840162	1	Center Shield, Conveyor Rear	
10	851134	6	CSHH, .375-16 x .750	
11	985669SRV	1	Shield, Front Support	
12	985057	2	Rubber, Front Outer	
13	985062SRV	2	Flashing, Side Strip Front Lip	
14	854084SRV	4	Pin, Pivot Side Panel	
15	851147A	2	Shield, Corner Rubber	
15A	854076-1	2	Clamp, Plate	
16	853816	1	Bottom Tank	
17	987264SRV	1	Safety Prop, Hopper	
18	840020	1	Cylinder, Hopper Lift	
—	870311	A/R	Seal Kit Universal, Hopper Wing	Not Shown
19	240030	2	Pin, Hydraulic Cylinder	
20	840157SRV	1	Hinged Panel, L/H	
21	840156SRV	1	Hinged Panel, R/H	
22	920032SRV	2	Guide Bar Assy	
23	920041SRV	2	Bar, Guide (Outer)	
24	920051SRV	2	Housing, Guide Bar (Inner)	
25	920061SRV	2	Rod & Chain, Guide Bar	
26	920070	2	Thumb Screw, .375-16 x 1.00	
27	985058	1	Rubber, Front Lip, Center	
28	985063SRV	1	Flashing, Center, Front Lip	
29	853598	2	Bar, .375 x 6.25 x 7.00	
30	853595	2	Bar, 125 x 1.50 x 9.50	
31	985581	1	Front Lip Clamp	
32	102-209-1A	10	CSHH, .375-16 x 2.00, GR5	
33	102-407-1A	4	CSHH, .500-13 x 1.50, GR5	
34	851111	1	CSSH, .500-13 x 2.00, GR5	

Hopper Components (components)

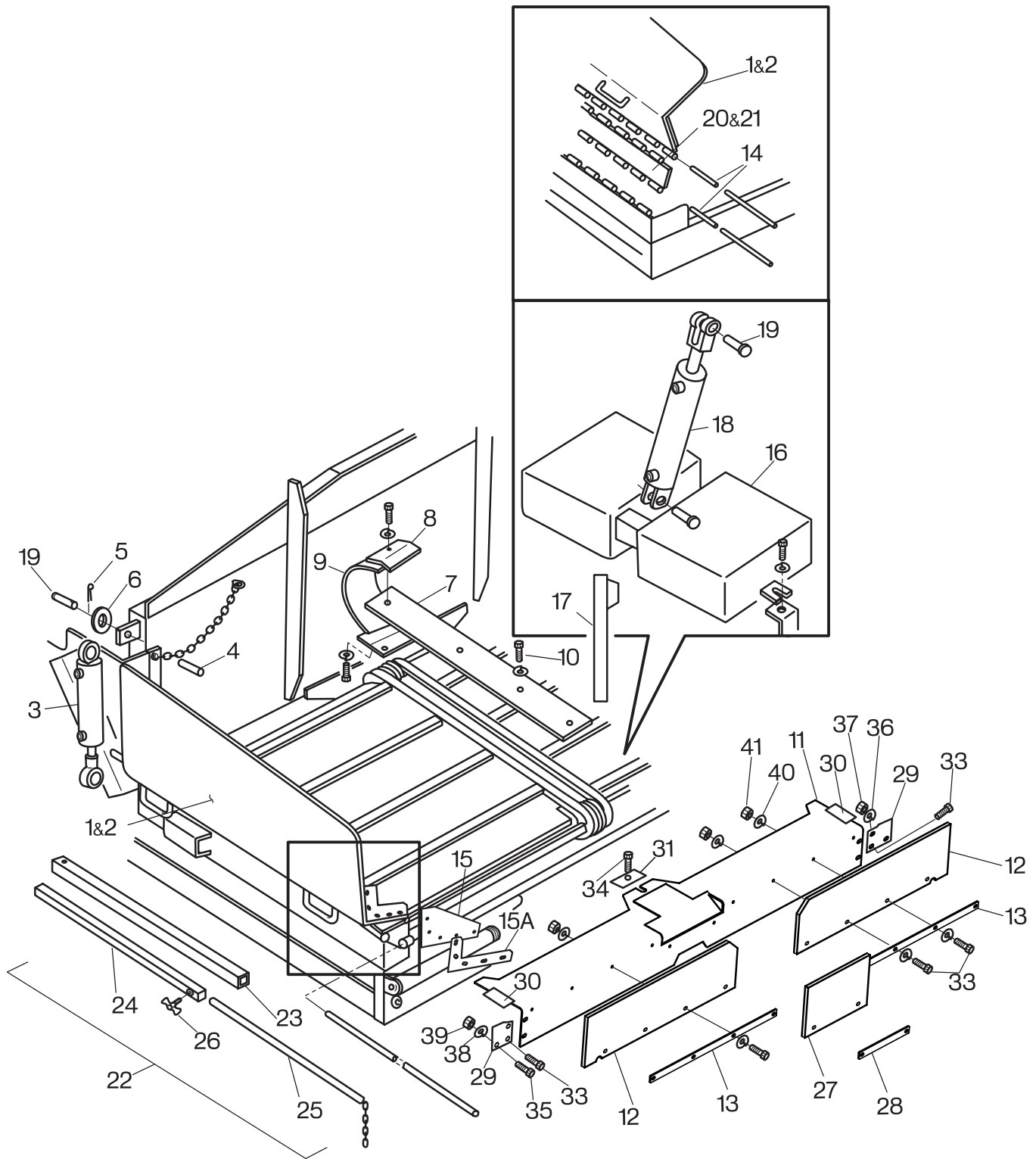

Figure 10-4

Hopper Components (components) Parts List

Item No.	Part Number	Qty.	Description	Remarks
35	102-607-1A	2	CSHH, .625-11 x 1.50, GR5	
36	118-7	2	Washer, Lock, .625	
37	117-5	8	Nut, Hex, Heavy, .625-11	
38	118-5	4	Washer, Lock, .500	
39	119-3	20	Washer, Flat, SAE, .375	
40	143-3	10	Nut, Lock, .375-16	

Auger Assembly

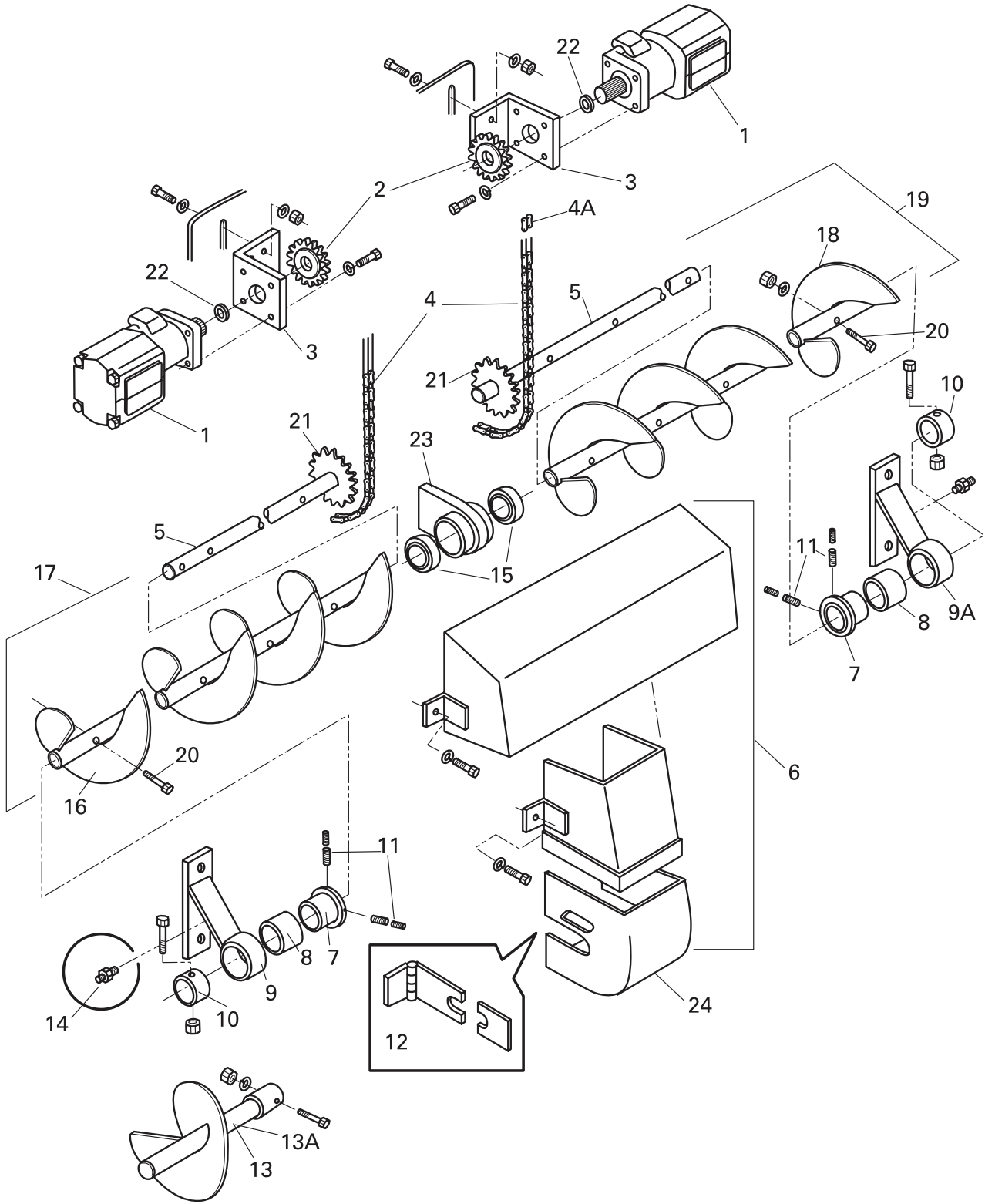

Figure 10-5

Auger Assembly Parts List

Item No.	Part Number	Qty.	Description	Remarks
1	987903	2	Hyd. Motor, Auger	
2	860030	2	Sprocket, Auger Drive Motor	
3	860021	2	Mounting Bracket, Auger Motor	
4	860090	2	Chain, Paver Auger Drive	
4A	860049	A/R	Master Link, 60H	
5	861130C	2	Shaft w/ Sprocket, Cast Auger	
6	860043SRV	1	Cover, Auger Chain Drive	
7	851645	1	Collar, Retaining Cap w/ Bolt	
8	810070	1	Bushing, 2.00 ID x 2.50 OD x 2.50	
9	860051HDRSRV	1	Auger End Mount, RH 8000/8500	
9A	860051HDLSRV	1	Auger End Mount, LH 8000/8500	
10	851647		End Cap, For Auger	
11	851645-1	A/R	Set Screws	
12	860043-1SRV	A/R	Kit, Auger Cover Closing	
13	860136	A/R	Auger Extension, RH	
13A	860135	A/R	Auger	
14	140610	A/R	Fitting Grease, Str., .250-28	
15	850130	2	Bearing	
16	861140C	4	Auger Section, RH	
17	860083	1	Auger Assy, RH	
18	861150C	4	Auger Section, LH	
19	860073	A/R	Auger Assy, LH	
20	861141	A/R	Bolt and Nut, Cast Auger	
21	860035	2	Sprocket, Auger Shaft	Weld On
22	860012	2	Seal Kit, Hyd. Motor	
23	853403	A/R	Center Auger Support	
24	853410	A/R	Auger Cover, Bottom	
-	851696SRV		Sonic Auger Kit	Optional, Not Shown

Conveyor Drive Cutoff, Screed Lift Cylinders

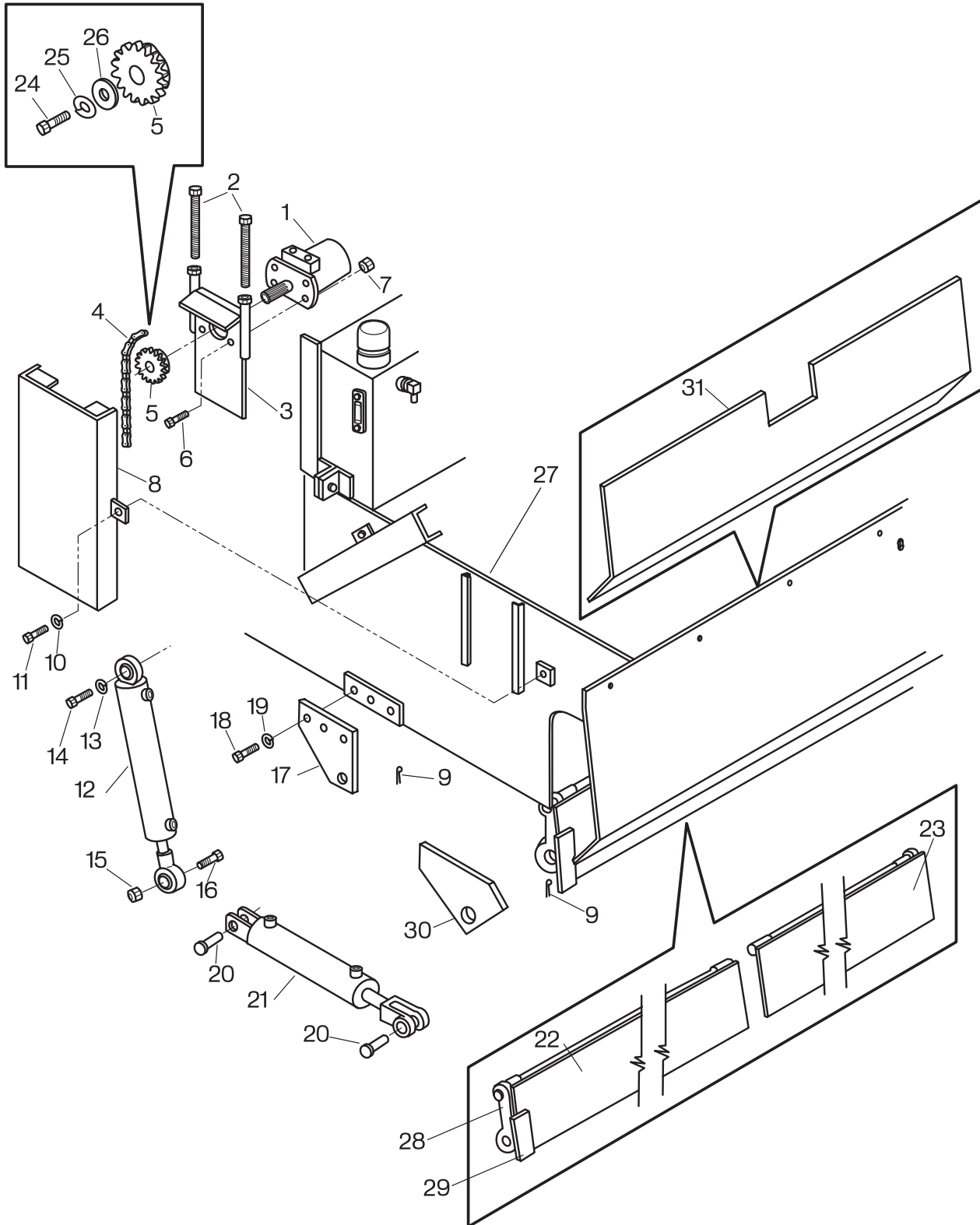

Figure 10-6

Conveyor Drive Cutoff, Screed Lift Cylinders Parts List

Item No.	Part Number	Qty.	Description	Remarks
1	1001027	2	Hyd. Motor, Conveyor Main	
–	1001027-01	1	Seal Kit, Hyd. Motor	
2	851148SRV	4	Bolt, Conveyor Drive Chain Adjuster	
3	851149SRV	2	Mount, Conveyor Drive Motor	
4	851121	2	Chain, Conveyor Drive (#80)	
5	851120	2	Sprocket, Conveyor Drive Motor	
6	851111	8	CSHH, .500-13 x 2.00	
7	116-5	8	Nut, .500-13 Hex	
8	854532SRV	1	Chain Guard, Conveyor L.H. Drive	
–	853572SRV	1	Chain Guard, Conveyor R.H. Drive	Not Shown
9	80338	4	Cotter Pin, .188 x 2.00 Long	
10	118-3	6	Washer, Lock, .375	
11	102-203-1A	6	CSSH, .375-16 x .750	
12	851436	2	Hyd. Cyl., Screed Lift (1000c / 8000c / 8500)	
–	851436-01	A/R	Seal Kit, Hyd. Cyl. 2.00 x 1.00	Not Shown
13	118-10	2	Washer, Lock, 1.00	
14	100-913-1A	2	CSHH, 1.00-14 x 3.00 GR8	
15	1002464	2	Nut, Lock, 1.00-14	
16	100-915-1A	2	CSHH, 1.00-14 x 3.50 GR8	
17	851152	2	Plate, Cutoff Cylinder Mount	
18	102-607-1A	6	CSHH, .625-11 x 1.50	
19	118-7	6	Washer, Lock, .625	
20	240030	2	Pin, Hydraulic Cylinder	
21	910170	2	Hyd. Cyl., Cutoff	
–	910170-01	A/R	Seal Kit, Hyd. Cyl. 2.50 x 1.25	Not Shown
22	851153SRV	1	Cutoff Left Side	
23	851154SRV	1	Cutoff Right Side	
24	102-5-1A	2	CSHH, .250-20 x 1.00	
25	118-1	2	Washer, Lock, .250	
26	860036	2	Washer, Fender (.250)	
27	Reference		Frame Body	
28	853497	2	Plate, Cut Off Cylinder Mount	
29	853593SRV	2	Bar, .250 x 2.00 x 7.00	
30	853596	2	Plate, Cut Off Gusset	
31	856781	1	Wear Plate, Auger Back	

Hydraulic Components LH Side Fuel Tank

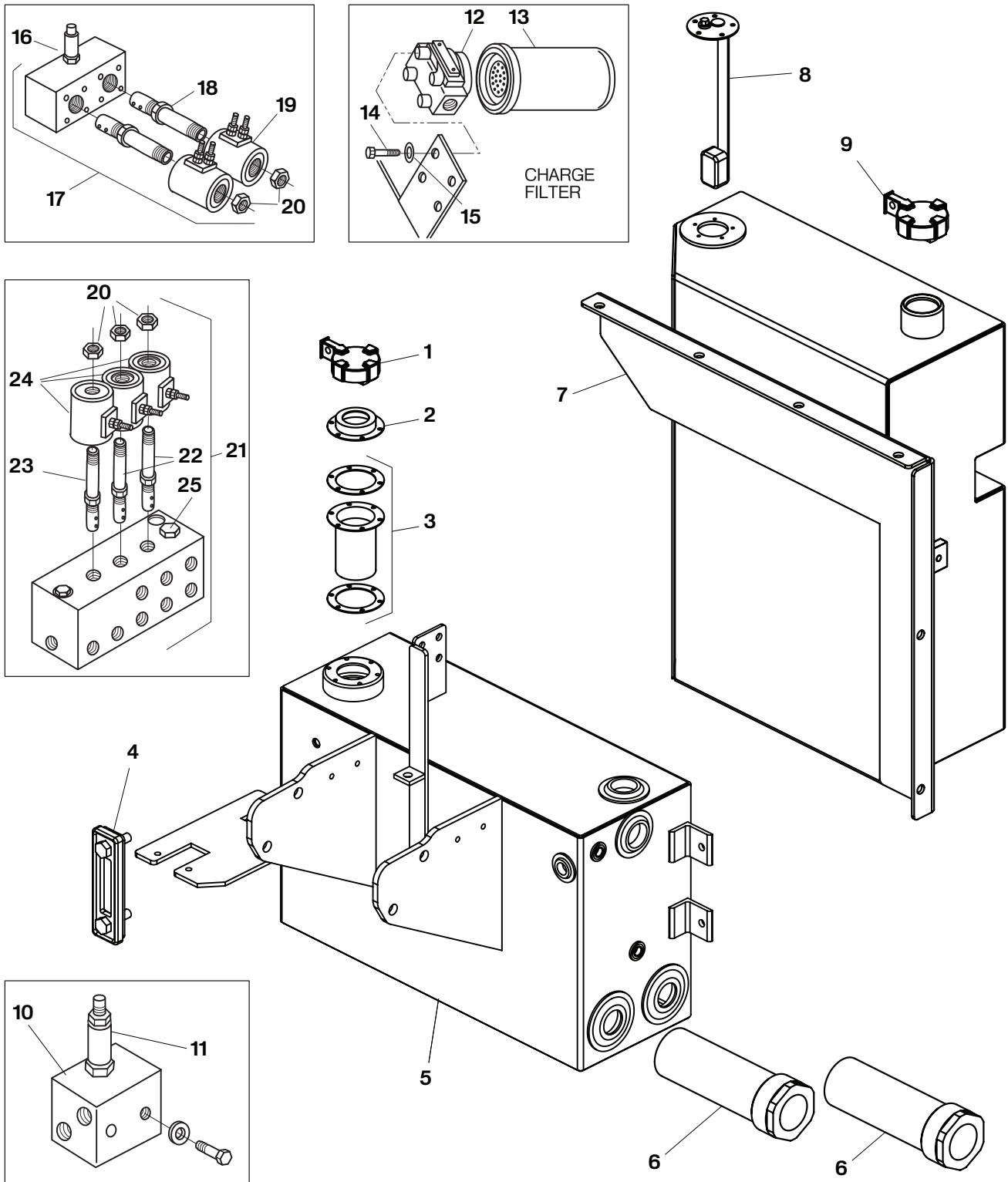

Figure 10-7

Hydraulic Components LH Side Fuel Tank Parts List

Item No.	Part Number	Qty.	Description	Remarks
1	140030HL	1	Cap, Hyd Tank, Lockable	
2	140030FN	1	Filler Neck	
3	140030GK	1	Strainer & Gasket Kit	
4	500070	1	Sight Gauge, Hyd. Oil Temp/Level	
5	1003117SRV	1	Assy, Tank Hydraulic	
6	36123	2	Filter, Hydraulic	
7	1003288SRV	1	Assy, Tank Fuel	Includes Item 8, 9
8	140040	1	Sending Unit, Fuel Tank	
9	140030FL	1	Cap, Fuel Tank, Lockable	
10	910122	1	Manifold, Side Wing	
11	910122-1	1	Relief Valve, Side Wing Manifold	
12	290010	1	Filter, Head, Charge/Return	
13	290030	1	Filter, Element, Charge/Return	
14	102-205-1A	4	CSHH, .375-16 x 1.00	
15	118-3	4	Washer, Lock, .375	
16	851628A-3	A/R	Valve, Relief, Conveyor Manifold (HPS)	
17	851628A	1	Manifold, Auto Conveyor (HPS)	
18	851628A-1	1	Cartridge Valve, Auto Conveyor (HPS)	
19	851628A-2	2	Coil, 12V (HPS)	
20	851628-3	2	Nut, Coil Retainer (HPS)	
21	850001	1	Manifold, Auto Auger/ 2-Speed (HPS)	
22	851235	2	Cartridge Valve, Auto Auger (HPS)	
23	851236	1	Cartridge Valve, 2-Speed (HPS)	
24	851237A	3	Coil, w/Diode, 12V	
25	851689	1	Flow Divider Screed	

Kubota Engine

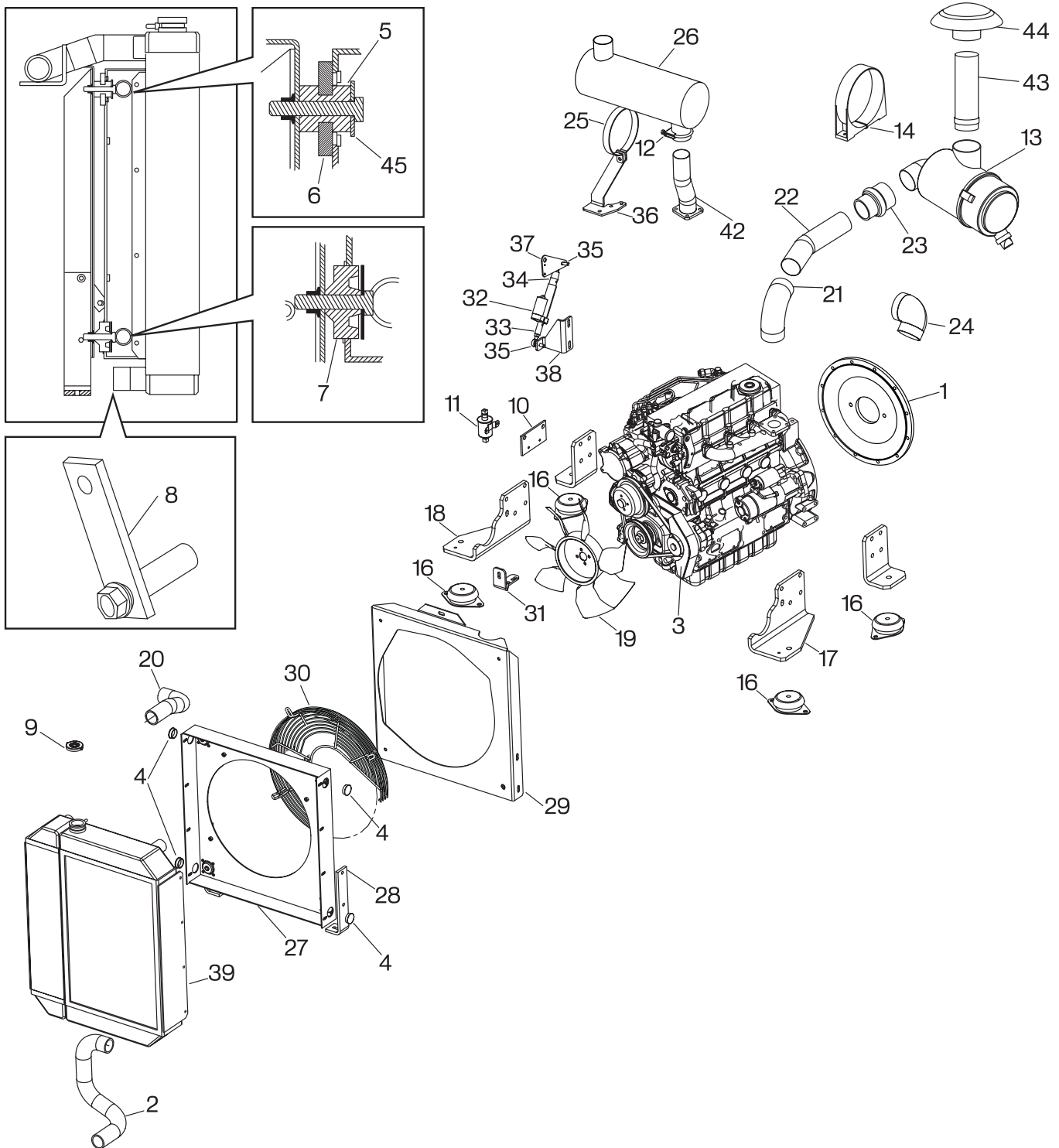

Figure 10-8

Kubota Engine Parts List

Item No.	Part Number	Qty.	Description	Remarks
–	1003139	1	Engine, Kubota, 85.5HP, Tier 3	Not Shown
–	1000867-10	1	Solenoid, Fuel w/ Diodes	Not Shown
–	1001166-03	1	Starter, Kub, Tier3, V3600TB	Not Shown
–	1001166-04	1	Alternator, Kub, Tier3, V3600TB	Not Shown
–	1001166-05	1	Belt, Engine, Kub, Tier3, V3600TB	Not Shown
–	1001166-09	4	Glow Plug, Kub, Tier3, V3600TB	Not Shown
1	1001166-11	1	Plate, Pump, Mnt, Kub, Tier3	
–	1001166-13	1	Tank, Coolant Recovery, Kubota	Not Shown
2	1001166-15	1	Hose, Radiator, Lower, Kub	
3	1001166-40	1	Guard, Belt, Kub, V3600TB	
–	1001166-42	1	Manual, Operators, Kub, V3600TB	Not Shown
–	1001166-43	1	Manual, Service, Kub, V3600TB	Not Shown
–	1001166-44	1	Manual, Workshop. Kub, V3600TB	Not Shown
–	1001166-45	1	Manual, Parts, Kub, V3600TB	Not Shown
4	1001166-56	4	Plug, Hole Cover, Rad Shroud	
5	1001166-57	2	Isolator, Rad Upper Mnt	
6	1001166-58	2	Plate, Rad Isolator Mnt	
7	1001166-59	2	Isolator, Rad Lower Mnt	
8	1001166-60	1	Bumper Assy, Rad Isolator Mnt	
9	1002184-04	1	Cap, Radiator, 13.5 Psi, 2.25" Neck	
10	1002184-17	1	Plate, Fuel Pump Brkt, Chalv kub	
11	1002184-18	1	Pump, Fuel, Electric, Kubota	
12	33312	2	Clamp, Muffler, .3125 x 2.5	
13	1003139-03	1	Air Cleaner Assy	
14	38385-05	1	Bracket, Air Cleaner Mount	
15	981511	4	Washer, Fender, .375	
–	982080-02	1	Filter Element, Fuel	Not Shown
–	986537-03	1	Filter Oil, Kubota	Not Shown
16	986537-14	4	Isolator,	
17	986537-16	1	Mount, Motor Lf Kubota	
18	986537-17	1	Mount, Motor Rf Kubota	
19	986537-19	1	Fan, Kubota	
20	986537-21	1	Hose, Radiator, Upper	
21	34030	1	Reducing Elbow, 3.0 x 2.5	
–	986537-26	1	Exhaust, Tip 90 Kubota	Not Shown
22	1003139-02	1	Intake, Tube, Kub	
23	37163	1	Reducer, 3.5 x 3.0	
24	986537-29	1	Air Breather 90 x 3" - 3.5"	

Kubota Engine (continued)

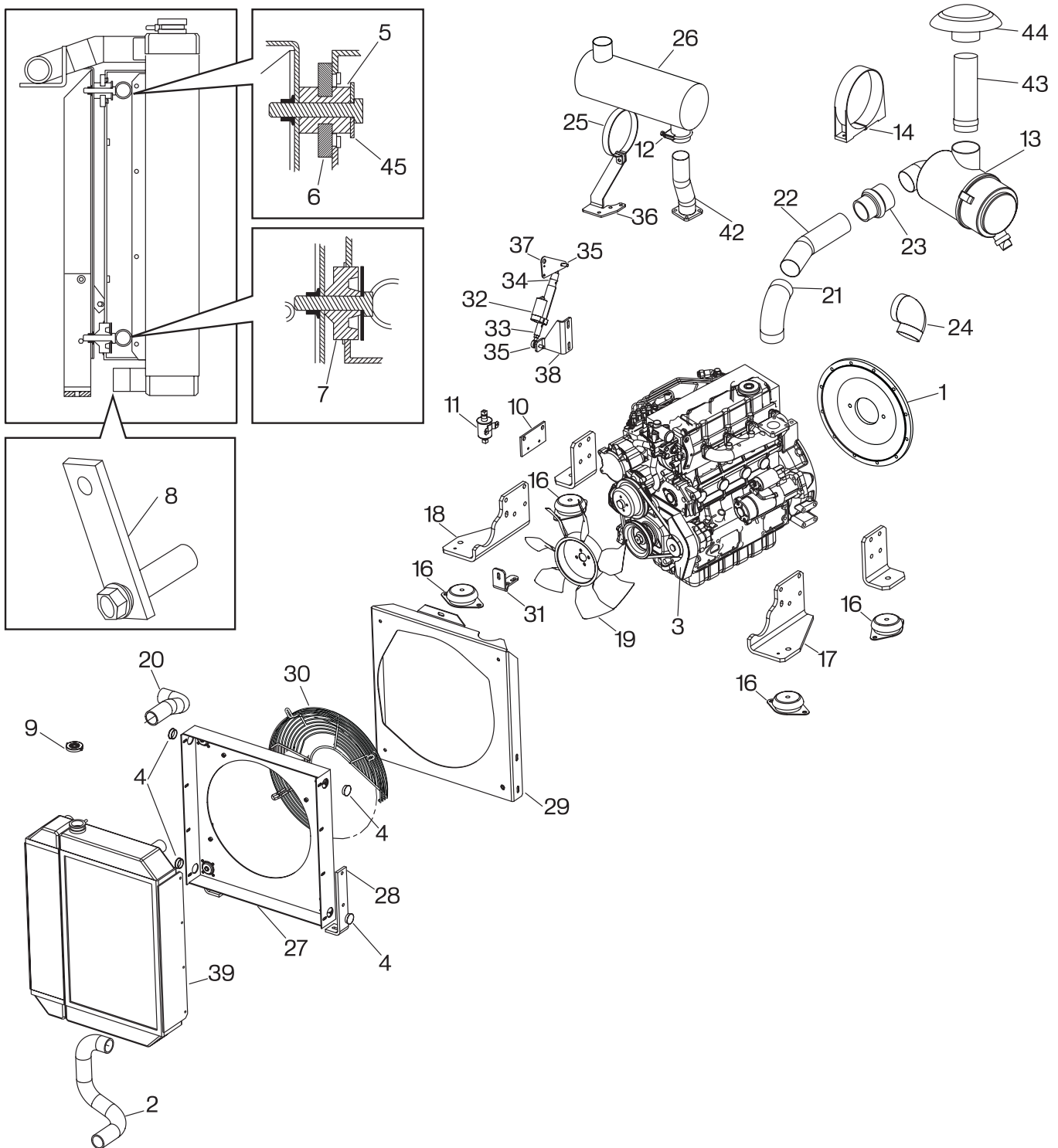

Figure 10-8

Kubota Engine Parts List (continued)

Item No.	Part Number	Qty.	Description	Remarks
25	986537-30	1	Muffler Strap, Engine	
–	986537-31	1	Filter, Fuel, In Line	Not Shown
26	986537-35	1	Muffler	
27	986537-40	1	Fan Shroud	
28	986537-42	2	Radiator Support Plate Foot	
29	986537-43	1	Radiator Support Plate	
30	986537-44	1	Fan Guard	
31	986537-45	1	Radiator Brace	
–	986537-50	1	Sending Unit, Water Temp, Kubota	Not Shown
–	986801	1	Cable, Bat, Pos, 2/0, 42"	Not Shown
–	986802	1	Cable, Bat, Neg, 2/0, 34"	Not Shown
–	987632	2	Flange, Shroud	Not Shown
32	987985	1	Actuator, Emulsion Throttle	
–	988169	1	Kit, Hose Oil Drain Kubota	Not Shown
33	980317	1	Adapter, Throttle Actuator Rod	
34	980318	1	Adapter, Throttle Actuator, Base	
35	982157	2	Ball Joint, .375, Male, w/ Stud	
36	988673-10	1	Muffler Brace, Kubota Engine	
37	988673-11	1	Throttle Bracket, Actuator, Kub	
38	988673-12	1	Throttle Mount, Actuator, Kub	
39	988673-13	1	Radiator/Cooler Assy, Kub	
40	988673-14	2	Engine Mount, Rear, Kub	
42	1003139-01	1	Exhaust, Nipple, Kub	
43	1003139-04	1	Tube, Inlet Air	
44	1003139-05	1	Inlet Hood	
45	981511	4	Washer, Fender, .375 x 2.00	
–	988673-17	1	Harness, Engine, V3600TB Kubota	Not Shown
–	988673-18	1	FITT, 90 02Mp-05Hb	Not Shown
–	988673-19	1	FITT, Str 02Mp-05Hb	Not Shown
–	989707	1	Sensor, Oil Pressure, 300 Kubota	Not Shown
–	80471	2	M8 x 1.25 nut	Not Shown
–	81291	2	M8 x 1.25 x 16 mm bolt w/ captive lock washer	Not Shown
–	80486	2	M8 x 1.25 x 22 mm bolt w/ captive lock washer	Not Shown
–	80478	16	M10 lock washer	Not Shown
–	811301	4	M10 x 1.25 x 16 mm socket head cap screw	Not Shown
–	81132	10	M10 x 1.25 x 25 mm bolt	Not Shown
–	Reference	1	M10 x 1.25 x 20 mm bolt w/ captive lock washer	Not Shown
–	80920	12	M10 x 1.25 x 30 mm hex head	Not Shown

Kubota Engine (continued)

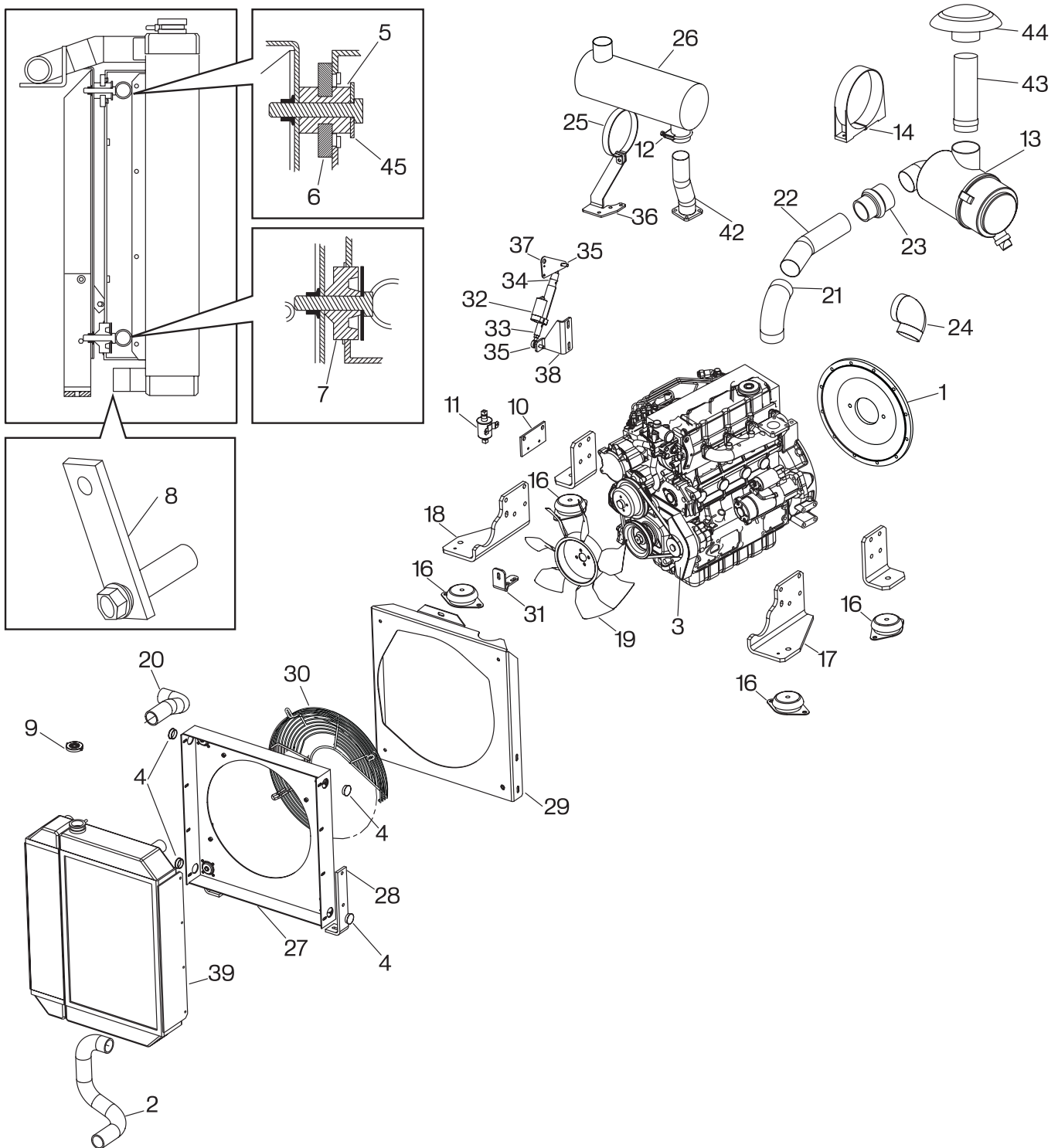

Figure 10-8

Kubota Engine Parts List (continued)

Item No.	Part Number	Qty.	Description	Remarks
–	Reference	10	M12 x 1.25 x 35mm bolt	Not Shown
–	Reference	4	M16 x 2.00 x 60 mm bolt	Not Shown
–	Reference	16	#10-32 x .750 serrated flange bolt	Not Shown
–	Reference	2	.250-20 x .500 serrated flange bolt	Not Shown
–	Reference	3	.250-20 x .625 serrated flange bolt	Not Shown
–	80187	1	.250-20 x 1.25 hex head bolt	Not Shown
–	80194	1	.250-20 x 1.50 hex head bolt	Not Shown
–	Reference	2	.250-20 serrated nut	Not Shown
–	80350	2	.250-20 nylock nut	Not Shown
–	Reference	8	.313-18 x .750 serrated flange bolt	Not Shown
–	Reference	1	.375-16 x .750 serrated flange bolt	Not Shown
–	80221	1	.375-16 x 1.00 bolt	Not Shown
–	104-205-1A	1	.375-16 x 1.00 serrated flange bolt	Not Shown
–	Reference	6	.375-16 x 1.25 serrated flange bolt	Not Shown
–	Reference	2	.375-16 x 2.00 serrated flange bolt	Not Shown
–	Reference	2	.375-16 x 2.25 serrated flange bolt	Not Shown
–	80996	6	.375 SAE flat washer	Not Shown
–	512156	2	.375 x 2.00 fender washer	Not Shown
–	80162	3	.375 lock washer	Not Shown
–	80038	1	.375-16 nut	Not Shown
–	80056	6	.375-24 hex nut	Not Shown
–	Reference	5	.375-16 serrated flange nut	Not Shown
–	80695	18	Washer, Flat, SAE, .500	Not Shown
–	80164	18	Washer, Lock, .500	Not Shown
–	80250	8	CSHH, .500-13 x 1.25	Not Shown
–	230240	4	Hose Clamp, 2.125 (Size 28)	Not Shown
–	986801	1	Cable, Battery	Starter to Battery Pos.
–	986802	1	Cable, Battery	Engine to Ground Post

Cat Engine

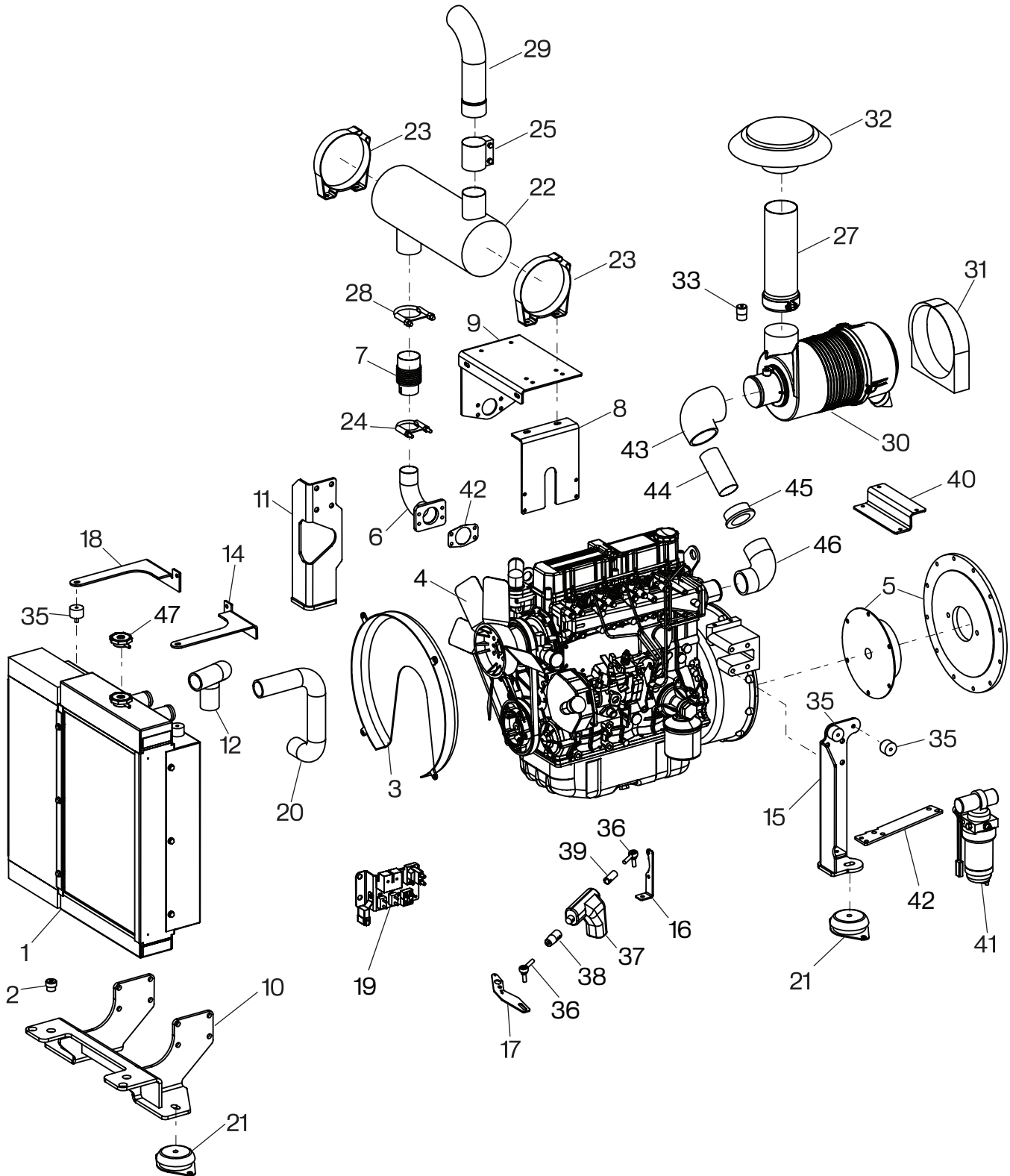

Figure 10-9

Cat Engine Parts List

Item No.	Part Number	Qty.	Description	Remarks
–	1003082	1	Cat C3.4t Tier3	Not Shown
–	1002917-33	1	Manual, CAT, C3.4, Ops and Maint	Not Shown
–	988671-03	1	Filter, Oil, CAT 3044T	Not Shown
–	988671-06	1	Belt, Engine, CAT C3.4T	Not Shown
–	988671-09	1	Starter, CAT C3.4T	Not Shown
–	988671-10	1	Alternator, CAT C3.4T	Not Shown
1	1002917-01	1	Radiator/Oil Cooler Combo	
2	1002917-02	4	Bottom Radiator Mount	
3	1002917-03	1	Guard,Fan Rd 18.625 2.00"DI	
4	1003082-13	1	Fan, Engine, Puller	
5	1002917-05	1	Coupling, Flywheel, Pump Drive	
6	1003082-02	1	Exhaust, Elbow with Flange	
7	1002917-07	1	Pipe, Exhaust, Flexible	
8	1003082-03	1	Bracket, Muffler, LH	
9	1003082-04	1	Bracket, Muffler, LH	
10	1002917-10	1	Mount, Front Engine and Radiator	
11	1002917-11	1	Mount, Engine, Right Rear	
12	1002917-12	1	Hose, Radiator, Upper	
14	1003082-06	1	Bracket, Radiator, Top Left	
15	1002917-16	1	Mount, Engine, Left Rear	
16	1002917-17	1	Bracket, Throttle Mount	
17	1002917-18	1	Plate, Throttle Lever, CAT	
18	1003082-07	1	Bracket, Radiator, Top Right	
19	1002917-13	1	Harness, CAT, Paver	
–	36085	2	Relay, 12VDC, SPDT, 40 Amp, 5 Pin	Not Shown
–	985751	1	Relay, 12VDC, SPST, 100 Amp, HD	Not Shown
–	1001617	1	Circuit Breaker, 80 Amp	Not Shown
–	34853	1	Circuit Breaker, 40 Amp	Not Shown
–	1003673	1	Circuit Breaker, 15 Amp	Not Shown
–	1002917-40	1	Bracket, Engine Relay	Not Shown
–	36086	2	Bracket, Relay Mount	Not Shown
–	983207	1	Conn, 12-Pin, SOC, DT04-12P	Not Shown
–	983217	1	Conn, Wedge, Recp, 12P, Deutsch	Not Shown
–	983199	1	Conn, 02-Pin, Plug, DT06-2S	Not Shown
–	983208	1	Conn, Wedge, Plug, 2P, Deutsch	Not Shown
–	985765	1	Conn, 04-Pin, Soc, DTPO4-4P	Not Shown
–	983213	1	Conn, Wedge, Recp, 4P, Deutsch	Not Shown
20	1002917-21	1	Hose, Radiator, Lower, CAT	

Cat Engine (continued)

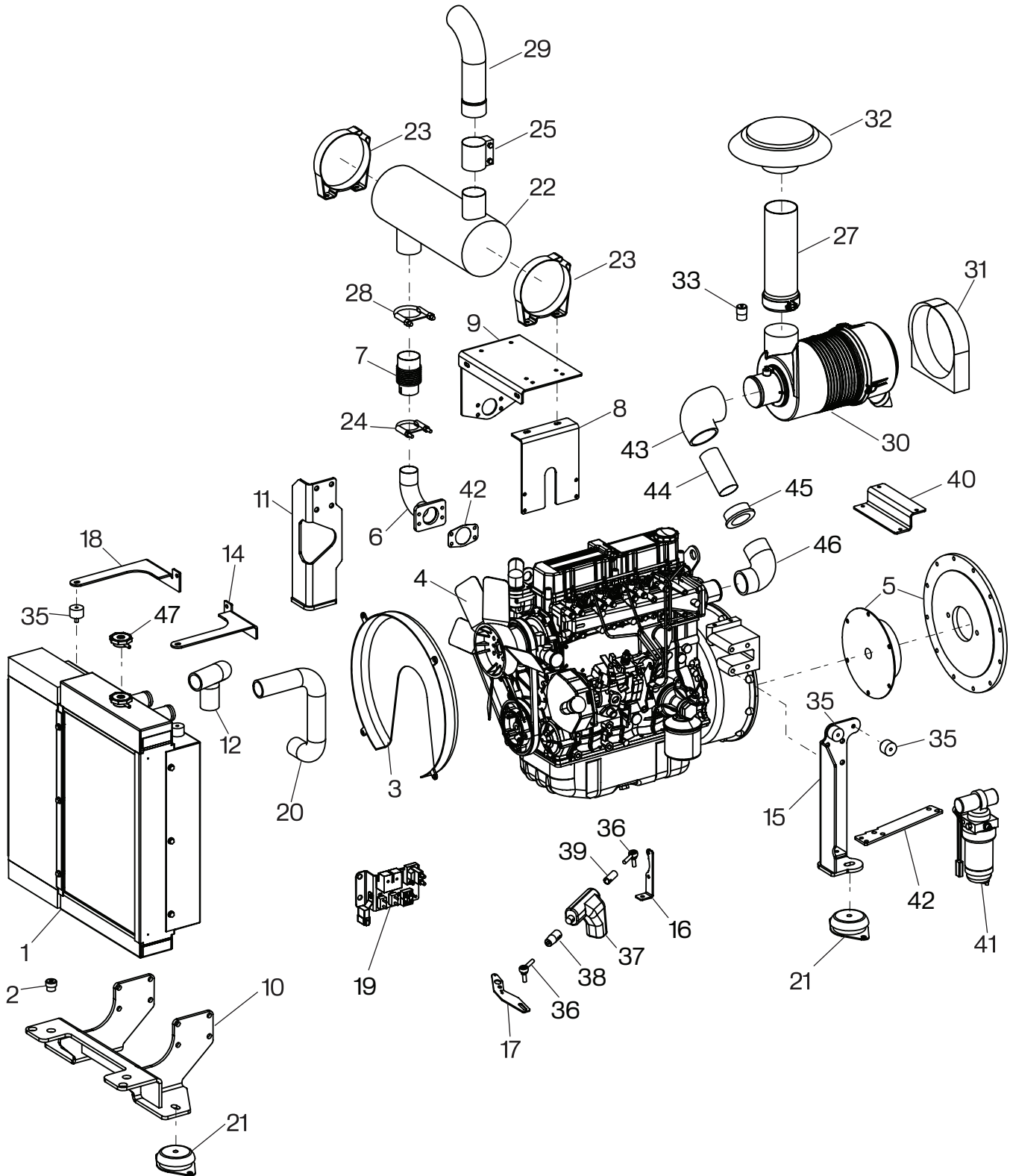

Figure 10-9

Cat Engine Parts List (continued)

Item No.	Part Number	Qty.	Description	Remarks
21	986537-14	4	Isolator	
22	986537-35	1	Muffler	
23	1002917-27	2	Clamp, Muffler Band, 6.62" ID	
24	71172	1	Clamp, Muffler, 2"	
25	1003082-09	1	Clamp, Muffler, Strap, 2.5 SS	
27	1003139-04	1	Tube, Inlet Air	
28	33312	1	Clamp, Muffler, .3125 x 2.50	
29	986537-26	1	Exhaust, Tip 90°	
30	38385	1	Air Cleaner Assy	
-	38385-01	1	Filter Element, Air Primary	Not Shown
-	38385-02	1	Filter Element, Air Secondary	Not Shown
-	38385-03	1	Cover, Air Cleaner	Not Shown
-	38385-04	1	Vacuator Valve, Air Cleaner	Not Shown
31	38385-05	1	Bracket, Air Cleaner Mount	
32	1002917-29	1	Inlet Hood	
35	1002917-32	4	Isolator, Rubber Mnt, .375 Thread	
36	982157	2	Ball Joint, .375, Male, w/Stud	
37	987985	1	Actuator, Emulsion Throttle	
38	980317	1	Adapter, Throttle Actuator Rod	
39	980318	1	Adapter, Throttle Actuator, Base	
40	1002924	1	Plate, Air Cleaner Mount	
41	984909-01	1	Filter Element, Fuel/Water	
42	1003082-05	05	Plate, Cable Control Mount	
43	986537-29	1	Elbow, Rubber, 90, 3.50 x 3.00	
44	1003082-12	1	Tube, 2.25 Air Intake, CAT	
45	1001140	1	Adapter, Rubber, Insert, 3.00 x 2.25	
46	1003082-08	1	Elbow, Rubber, 90, 2.25 ID	
47	1002917-39	1	Cap, Radiator	
-	71771	1	Fitt, 90 12MJ-16MB	Not Shown
-	38203	1	Fitt, 45 12MJ-16MB	Not Shown
-	1002917-22	1	Switch, Temp, 240F .250 NPT	Not Shown
-	984909-10	1	Fitt, Str 02MBSTP-02FP	Not Shown
-	1002917-23	1	Washer, Seal, AL, .636 ID x .813 OD	Not Shown
-	1002917-24	1	Fitt, Tee 02FP-02FP-02FP	Not Shown
-	1002917-25	2	Fitt, Str 04FP-05MB	Not Shown
-	38279	1	Fitt, 90 04MP-05HB	Not Shown
-	33277	2	Clamp, Hose, #4	Not Shown
-	33169	4	Clamp, Hose, #28	Not Shown

Cat Engine (continued)

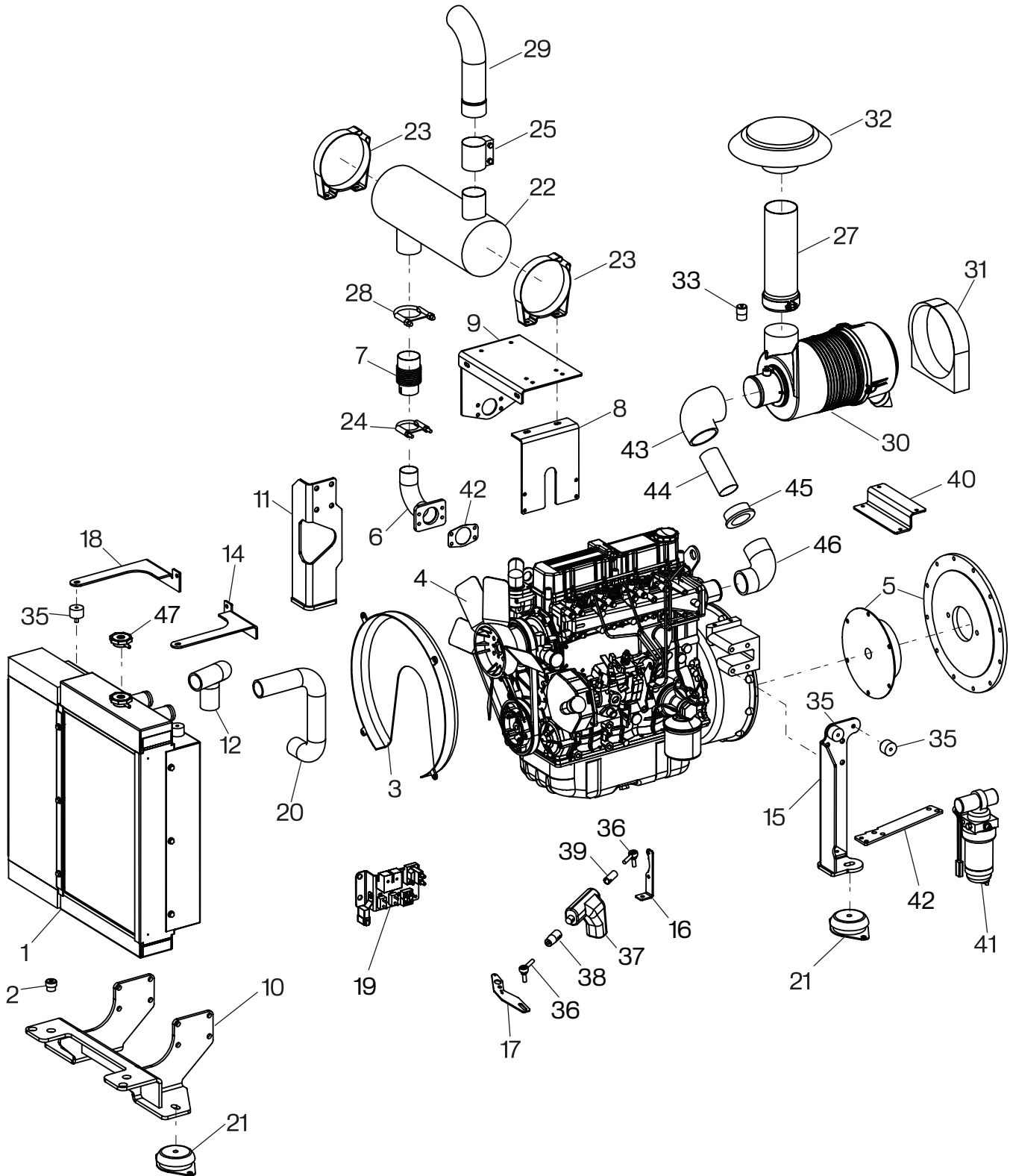

Figure 10-9

Cat Engine Parts List (continued)

Item No.	Part Number	Qty.	Description	Remarks
-	988673-19	2	Fitt, Str 02MP-05HB	Not Shown
-	988821-09	2	Pin, Male, 16-20 AWG, Deutsch	Not Shown
-	983209	1	Conn, Wedge, Recp, 2P, Deutsch	Not Shown
-	983198	1	Conn, 02-Pin, Soc, DT04-2p	Not Shown
-	1003082-10	1	Fitt, 90 06MJ-M14, Metric O-ring	Not Shown
-	31959	1	Fitt, Str 06MP-o6HB, Push On	Not Shown
-	1003082-11	1	Fitt, Cap 06FP	Not Shown
-	37331	1	Fitt, Str 02MP-02MP, Brass	Not Shown
-	1002917-35	1	Cable, Battery, Pos, 50", Eye/Eye	Not Shown
-	1002917-36	1	Cable, Battery, Neg, 16", Eye/Eye	Not Shown
-	1002917-27	1	Sender, Press, 0-100 PSI, 02MP	Not Shown
-	1002917-28	1	Sender, Temp, 100-250 F, 06MP	Not Shown

Pump Components

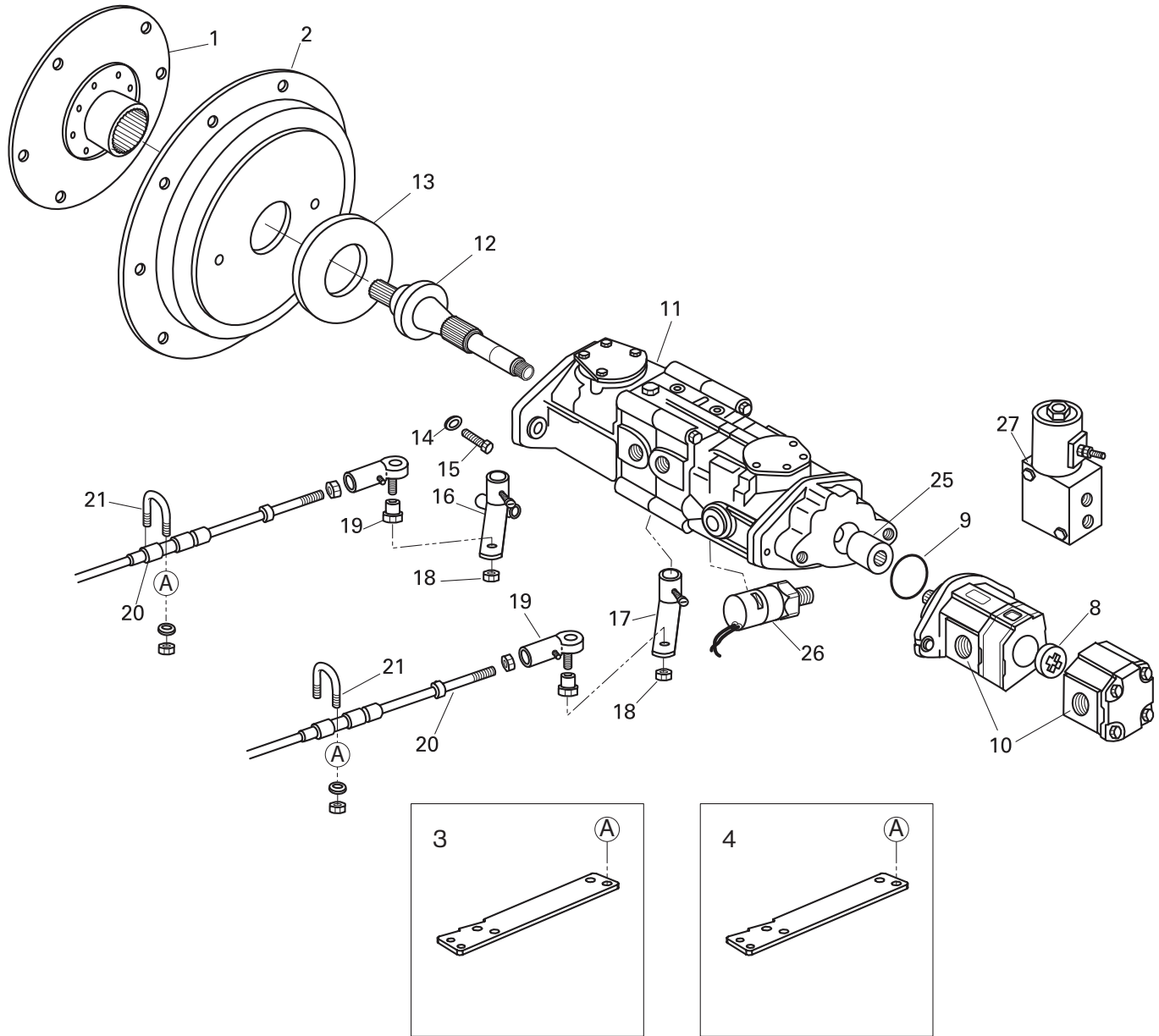

Figure 10-10

Pump Components Parts List

Item No.	Part Number	Qty.	Description	Remarks
1	851479	1	Pump Drive Plate, Flywheel	
2	320200	1	Cover, Pump Plate	
3	1003653	1	Assy, Cable Mount	Kubota
4	1003082-05	1	Plate, Cable Control Mount	CAT
8	851160-1	1	Drive Cplg. Charge Pump	
9	320235	1	O-Ring,	Piggyback To Main Pump
10	984483	1	High Volume Pump, Augers And Conveyors	
11	320416	1	Pump, L.&R. Drive Sun Strand	
12	851495A	1	Shaft, New Style	Seal Size 2 7/8" Outside
13	851489A		Seal, New Style Front Sundstrand	2 7/8" Outside
14	118-5	2	Washer, Lock, .500	
—	120-5	2	Washer, Flat, .500	Not Shown
15	811364	2	CSHH, .500-13 x 1.50, GR5	
16	320245	1	Arm, Left Drive	
17	900025	1	Arm, Right Drive	
18	900027	2	Nut	
19	920090	2	Spherical Rod End, W / Stud	
20	920120	2	Cable, R.H. Drive, Auger & Pump (104" X 3")	
21	350060	2	U-Bolt, 3/8"	
25	851160-2	1	Drive Cplg, Tandem Pump	
26	851504	1	Backup Alarm, Pressure Switch	

Main Valve And Spray Down (Option)

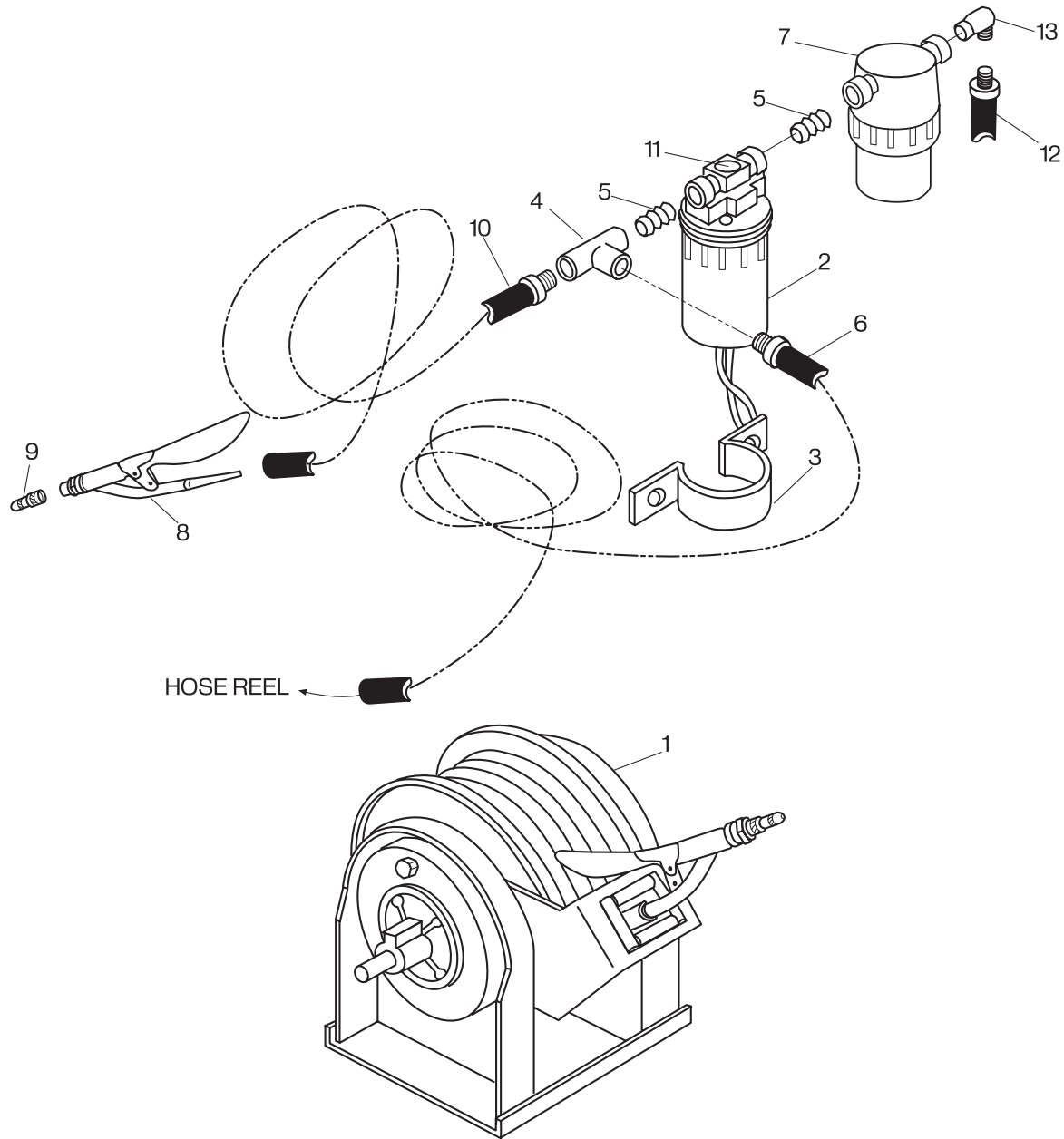

Figure 10-11

Main Valve And Spray Down (Option) Parts List

Item No.	Part Number	Qty.	Description	Remarks
1	920200	1	Hose Reel, Machine Washdown	
2	1001542	1	Pump, Spraydown	
3	480260	1	Bracket, Water/Fuel Pump Mount	
4	920222	1	Tee, .375	
5	99638	1	Nipple, .375	
6	984338	1	Hose, Pump to Hose Reel, 5'	
7	36926	1	Strainer	See item 2
8	920220	2	Handle & Nozzle, Spraydown	
–	33277	2	Clamp, Hose #4	
9	901210A	A/R	Nozzle, Spraydown Handle	
10	984339	2	Hose, 15'	to Spraydown Handle
11	851448	A/R	Pressure Switch (Flowjet Pump)	
12	984339	1	Hose, 15'	to Tank
–	1001428SRV	A/R	Kit, Spraydown Pump and Strainer	Includes Items 2, 7
13	34536	1	FITT, 90 06MJ-08MP	

Screed Arm Assembly With Manual or Electric Toe Point

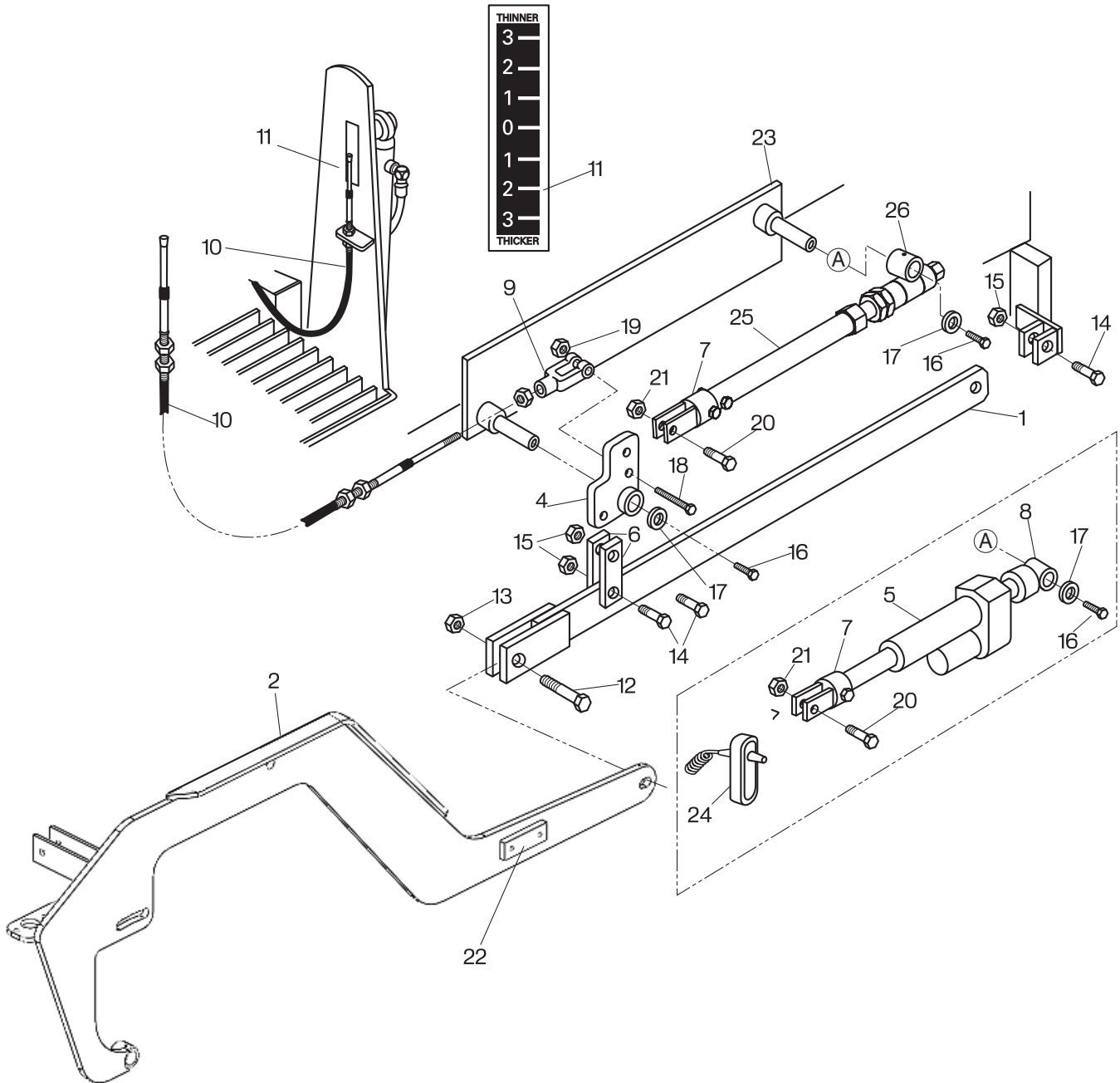

Figure 10-12

Screed Arm Assembly With Manual or Electric Toe Point Parts List

Item No.	Part Number	Qty.	Description	Remarks
1	851206SRV	1	Extension, Screed Arm	
2	982743RSRV	1	Assy, Screed Arm, RH	Reference Only, See Fig 10-46
–	982743LSRV	1	Assy, Screed Arm, LH	Reference Only, See Fig 10-45
4	851209SRV	1	Mount, Pivot	
5	851518	2	Screw, Electric (6.00")	Optional
6	851210SRV	2	Ears, Pivot	
7	851211	1	End, Rod End of Screw	Optional
8	851212	1	End, Motor End of Screw	Optional
9	851213	1	Clevis, .188 x .250	
10	851520	1	Cable, Height Locator .188 x 90 w/5.00" Stroke	
11	851215	1	Decal, Height	
12	102-411-1A	1	CSHH, .500-13 x 2.50	
13	116-10	1	Nut, Lock 1.00-8	
14	102-611-1A	3	CSHH, .625-11 x 2.50	
15	116-7	3	Nut, Lock, .625-11	
16	851134	2	CSHH, .375-16 x .750	
17	119-3	2	Washer, Fender .375	
18	102-9-1A	1	CSHH, .250 x 2.00	
19	116-1	1	Nut, Lock, .250	
20	102-408-1A	2	CSHH, .500-13 x 1.75	
21	115-5-A	2	Nut, Lock, .500	
22	855568	1	Bracket, Grade Control	
23	853586SRV	1	Mounting Plate 6" Electric Screw, RH	
–	853585SRV	1	Mounting Plate 6" Electric Screw, LH	Not Shown
24	852900	1	Assy, Remote, Electric Flight Screw	2 Remotes and Junction Box
–	900080	A/R	Switch, Toggle, 3 Pos Rev. DPDT MO	Not Shown
–	900082	A/R	Curly Cord	Not Shown
–	920238	A/R	Handle, Cord and Switch One	Not Shown
25	1003107	2	Assy, Manual Screw	Includes Items 7 and 26
26	1003333SRV	2	End, Adjuster End	

Propane Heater And Automatic Ignitors Parts List

Item No.	Part Number	Qty.	Description	Remarks
1	230010	1	L.P.G. Tank, 20 lbs	
2	230030	1	Adapter, P.O.L.	
3	230110	1	Gauge, L.P.G. Pressure	
4	230300	1	Solenoid Valve, 12 Volt L.P.G.	
5	982515	1	Regulator w/Gauge, L.P.G.	
6	230032	1	Hose, L.P.G. Regulator to Tee	
7	230034	2	Hose, Screed Burner	
8	230080	2	Tee, 1/4" Pipe	
9	230081	2	Tee, 1/4" Street	
10	230038	2	Hose, Screed Extension Burner	
11	230070	5	Valve, Selector (Cutoff)	
12	230069	3	Adapter, Hose to Pipe (90 deg)	
13	851225	2	Hose, Screed Extension Burner	
14	230169	3	Coupling, 1/4" Pipe	
15	99593	3	Pipe Nipple, 1/4" Pipe	
16	230169	3	Coupling, 1/4" Pipe	
17	982504	2	Burner, Wand, Assy. ST 5 Ignitor	
18	230240	2	Hose Clamp, 2 1/8" (Size 28)	
19	982501	A/R	Burner Nozzle, Ignitor	
20	982503	2	Burner Nozzle, Screed Extension	
21	230084	2	Quick Disconnect Coupling	
22	230024	2	Ignitor, Ceramic, Hot Surface	
23	230034	1	Hose, Ignitor Burner	

Auger Extension

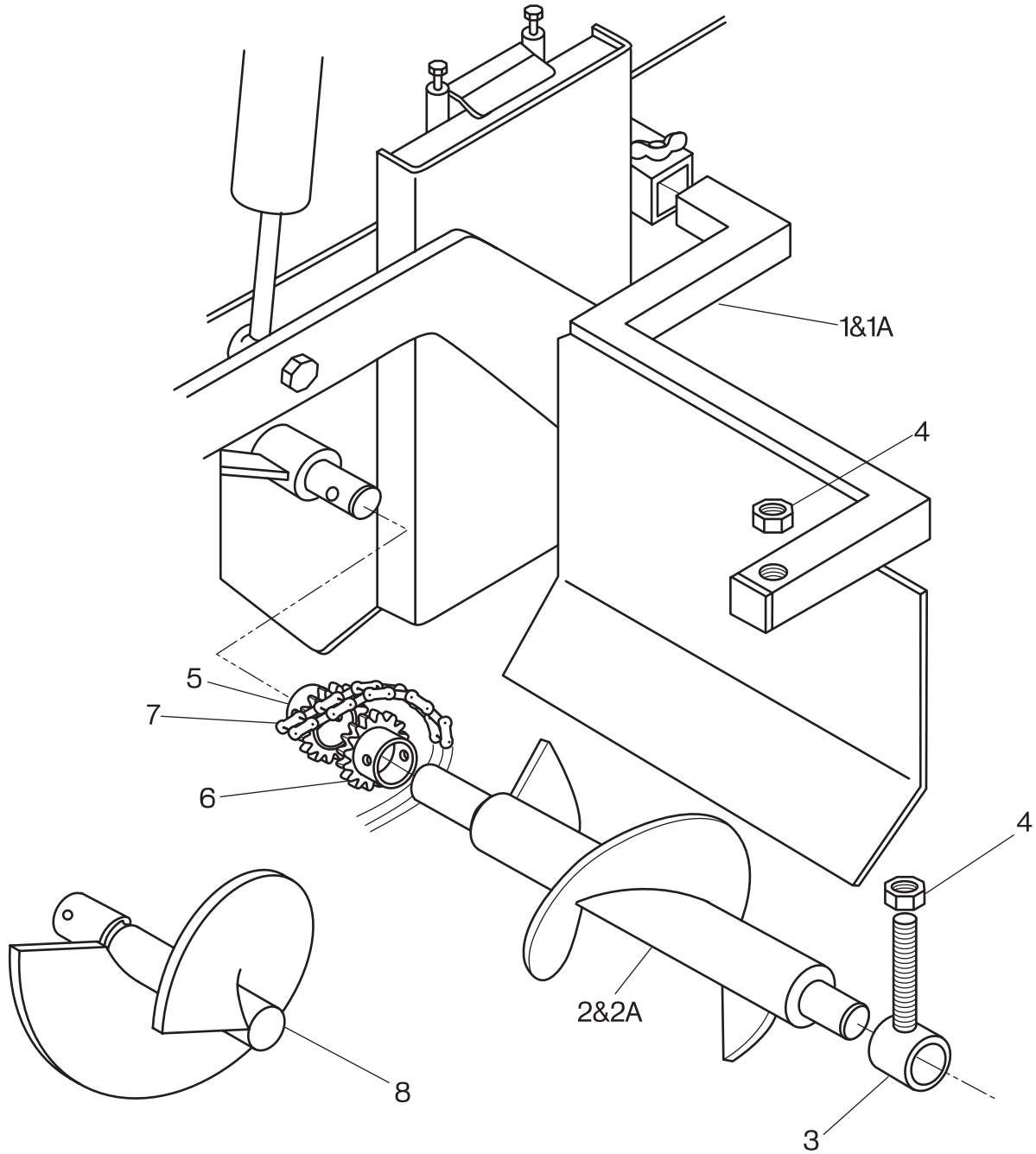

Figure 10-14

Auger Extension Parts List

Item No.	Part Number	Qty.	Description	Remarks
–	982521SRV	1	Auger Extension Kit, 24”	Includes Items 1, 1A, 2, 2A
1	851227SRV	1	Shield, Auger Extension (RH)	
1A	851228SRV	1	Shield, Auger Extension (LH)	Not Shown
2	851229SRV	1	Auger Extension, RH, 24”	
2A	851230SRV	1	Auger Extension, LH, 24”	Not Shown
3	851231SRV	1	Support, Auger Adjustable	
4	116-10	2	Nut, Hex 1”	
5	854003	1	Coupling Half	
6	854004	1	Coupling Half, Weldment	
7	900404	1	Double Row Chain Assembly (50-2)	
8	860136	1	Auger Extension Kit, RH	
–	860135	1	Auger Extension Kit, LH	Not Shown

Paver Leveling Control (TOPCON) System 4 Parts List

Item No.	Part Number	Qty.	Description	Remarks
1	851241SRV	2	Housing, Rear Slide Bar	
2	851242SRV	2	Bar, Adjustable Slide	
3	920070	2	Thumb Screw, .375-16 x 1.00	
4	851243SRV	2	Housing, Front Slide Bar	
5	143-5	2	Nut, Lock, .500-13	
6	851249SRV	2	Skid	
7	102-411-1A	2	CSHH, .500-13 x 2.50	
8	981981	2	Alum. Cable Sleeve .0625	
9	851245	1	Spring, Tension	
10	851246	1	Cable 1.0625	
11	851247SRV	1	Arm, Skid Support (Rear)	
12	851248SRV	1	Arm, Skid Support (Front)	
13	102-611-1A	1	CSHH, .625-11 x 2.50	
14	116-7	1	Nut, Lock, .625-11	
15	851578	1	Bracket, Sonic Tracker	
16	119-7	1	Washer, Flat, SAE, .625	
17	102-617-1A	1	CSHH, .625-11 x 4.00 GR5	
18	985866	1	AM Module and Cable Assy, w/Base Plate	
–	985866-01	1	AM Module Only	Not Shown
–	984596	1	Assy, Cord Remote (TOPCON)	Not Shown
19	851579	1	Sonic Tracker	
20	851581	1	Wire Bail, Temperature	
21	851265	1	Case For Sonic Tracker	
22	851575SRV	2	Pivot Mount, TOPCON/Spectra Physics	
23	9090-1125SRV	1	Bracket, Z Arm, TOPCON	
24	300060	1	Handle, Bolt, .625-11	
25	102-606-1A	1	CSHH, .625-11 x 1.25 GR5	
26	119-7	1	Washer, Flat, SAE, .625	
27	851421	A/R	Slope Meter	
28	851574	A/R	Coiled Cord, TOPCON Tracker/Slope	
–	851584SRV	1	Assy, 20 Ft. Kit	Not Shown
–	851585SRV	1	Assy, 30 Ft. to 40 Ft. Kit	Not Shown
29	986609	2	Coiled Cord, Remote TOPCON	
–	987053SRV	1	Kit, AM Module with Remote	Includes Items 18, 29
30	985866-02	1	Cable, AM Module Only	Not Shown

Paver Leveling Control (TOPCON) System 5

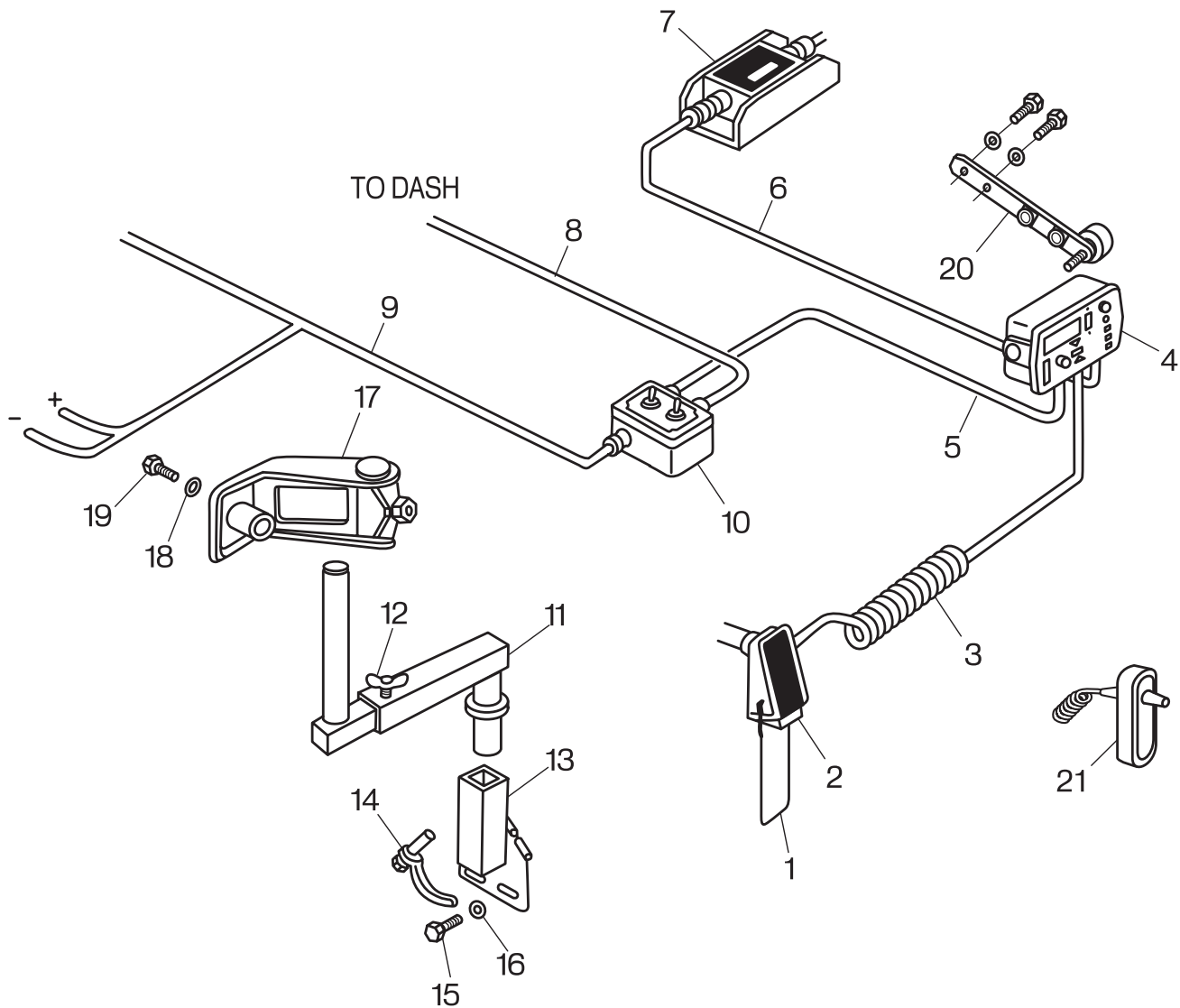

Figure 10-16

Paver Leveling Control (TOPCON) System 5 Parts List

Item No.	Part Number	Qty.	Description	Remarks
1	983414-10	2	Assy Temp. Bail w/Sleeves	
2	983414-01	2	TSD Sonic Tracker II	
3	983414-08	2	Coil Cord, 15ft CA to Tracker	
4	983414-02	2	TSD 3 Conn SS Paver Box	
5	983416-01	2	Cable J-Box to Control Box	
6	983414-14	2	Slope Cable 5 Foot	
7	983414-13	2	Slope Sensor	
8	984596	2	Assy, Cord Remote (TOPCON)	
9	985866-02	2	Cable, AM Module Only	
10	985866-01	2	AM Module Only	
11	9090-1125SRV	2	Bracket, Z Arm, TOPCON	
12	920070	2	Thumb Screw, .375-16 x 1.00	
13	851575SRV	2	Pivot Mount, TOPCON/Spectra Physics	
14	300060	2	Handle, Bolt, .625-11	
15	102-606-1A	4	CSHH, .625-11 x 1.25 GR5	
16	119-7	4	Washer, Flat, SAE, .625	
17	851578	2	Bracket, Sonic Tracker	
18	119-7	2	Washer, Flat, SAE, .625	
19	102-617-1A	2	CSHH, .625-11 x 4.00 GR8	
20	983414-09	2	Assy CB Bracket	
–	988288SRV	1	Dual Grade & Slope	System 5 Kit, Not Shown
–	988409SRV	1	Dual Grade Control	System 5 Kit, Not Shown
21	986609	2	Coiled Cord, Remote TOPCON	

Truck Hitch Assembly

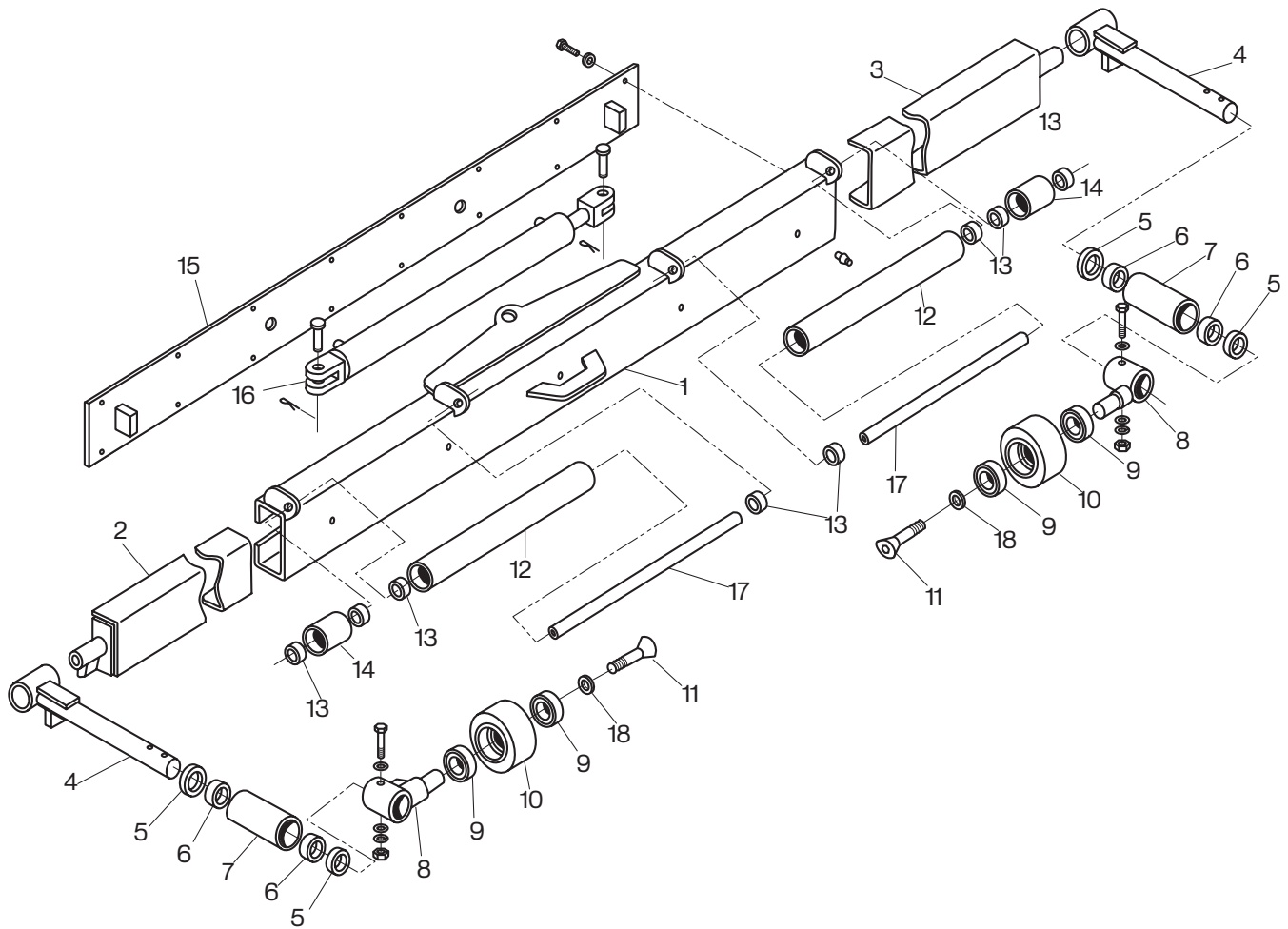

Figure 10-17

Truck Hitch Assembly Parts List

Item No.	Part Number	Qty.	Description	Remarks
–	1000253SRV		Truck Hitch Assembly	Not Shown
1	930015	1	Support, Pivot Bar	
2	930020SRV	1	Arm Extension, RH	
3	930025SRV	1	Arm Extension, LH	
4	930030SRV	2	Arm, Assy, Truck Hitch Wheel Pivot	
5	620400	4	Collar, Lock	
6	810070	4	Bushing, Track Idler/Truck Hitch	
7	930040	2	Roller	
8	930045SRV	2	Assy, Axle, Guide Wheel	
9	930050	2	Bearing, Truck Hitch Roller	
10	930055	2	Guide Wheel, Truck Hitch	
11	851111	2	Capscrew, 1/2-13" X 2 Flat Head Socket	
12	810102	2	Push Roller, Truck Wheel	
13	810110	8	Bearing, Push Roller (1 1/4")	
14	930060	2	Roller Extension, Bumper	
15	930065	1	Cover, Back Panel	
16	930070	1	Cylinder, Arm Extension	
17	930075	2	Shaft, Bumper Roller	
18	851112	2	Washer, Counter Sunk	
–	984399	1	Hose Kit 8515 Truck Hitch	Not Shown
–	910120	1	Selector Valve, Conveyor	Not Shown

Controls - Right Side High Deck

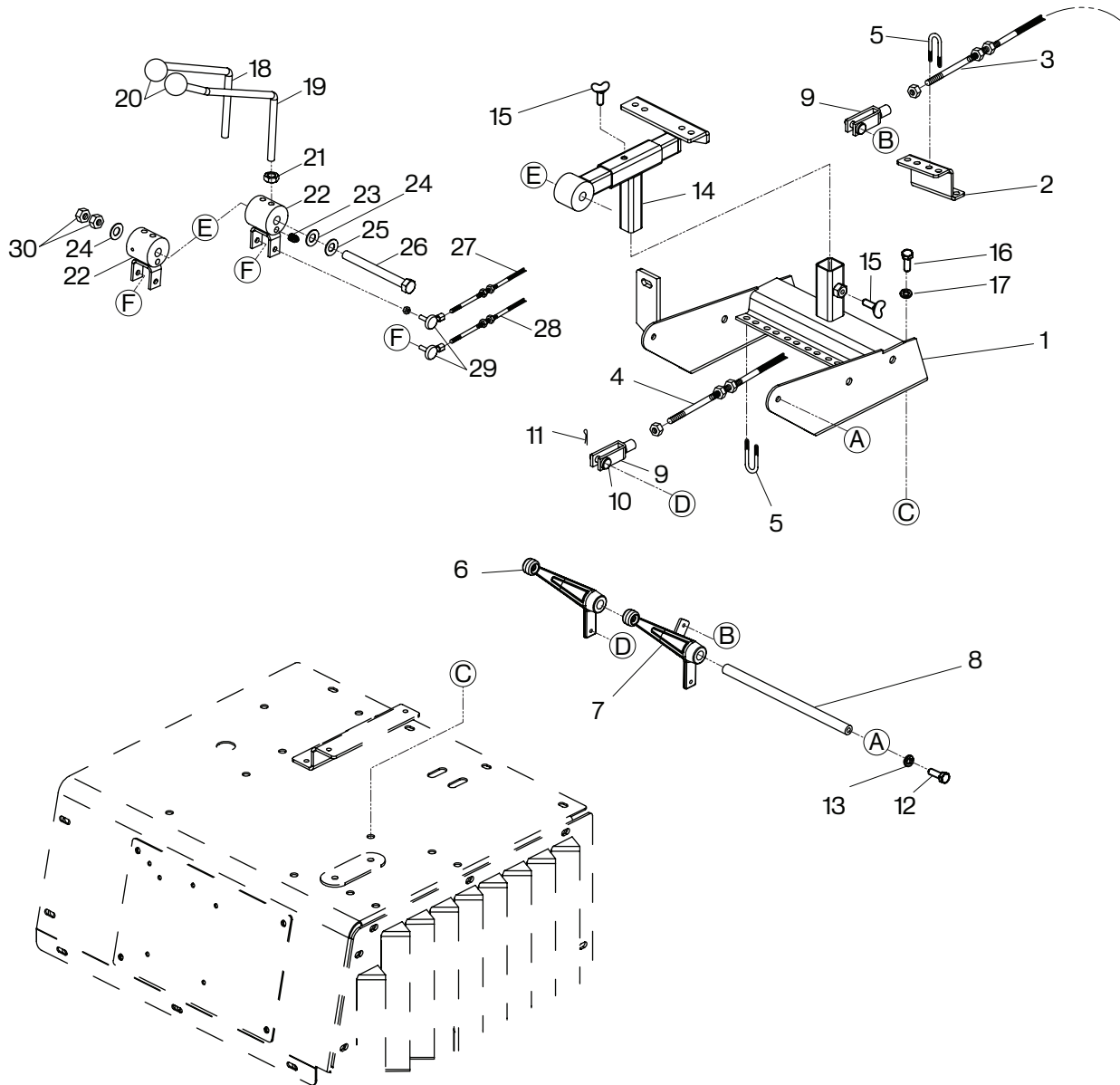

Figure 10-18

Controls - Right Side High Deck Parts List

Item No.	Part Number	Qty.	Description	Remarks
1	1003504	1	Mount, RH Controls, HD	
2	988122	1	Mount, Cable, RH	
3	920120	2	Cable, Push Pull	
4	920136	6	Cable	
5	350060	8	U-Bolt, .375-16	
6	920210	6	Cast Handle, RH Control (Mod)	
7	920210-02	2	Cast Handle	
8	988202	1	Rod, Control Handles, 12.00	
9	350050	8	Clevis, .250-28	
10	350080	8	Pin, Clevis, .250 x .875	
11	960019	8	Pin, Cotter, .094 x .750	
12	100-203-1A	2	CSHH, .375-24 x .750	
13	118-3	2	Washer, Lock, .375	
14	1003113	1	W/M, RH Drive Controls	
15	920070	2	Thumb Screw, .375 -16 x 1.00	
16	102-105-1A	4	CSHH, .312-18 x 1.00	
17	118-2	4	Washer, Lock, .312	
18	920097L	1	Handle, Drive, LH	
19	920097R	1	Handle, Drive, RH	
20	920225	4	Knob, Round Ball, .500-13 x R1.875	
21	116-5-1	4	Nut, Jam, .500-13	
22	920094	2	RH Pivot, F/R Lever	
23	920095	2	Ball, Plunger, .500-13	
24	119-7	2	Washer, Flat, .625	
25	490080	1	Washer, Bevel, .625	
26	920229	1	CSHH, .625-11 x 7.50	
27	920130	2	Cable, RH Control	123" x 3" Stroke
28	920120	2	Cable, RH Drive, Auger and Pump	104" x 3" Stroke
29	920090	4	Spherical Rod End, w/ Stud	
30	116-7-1	2	Nut, Jam, .625-11	

Controls - Right Side Low Deck

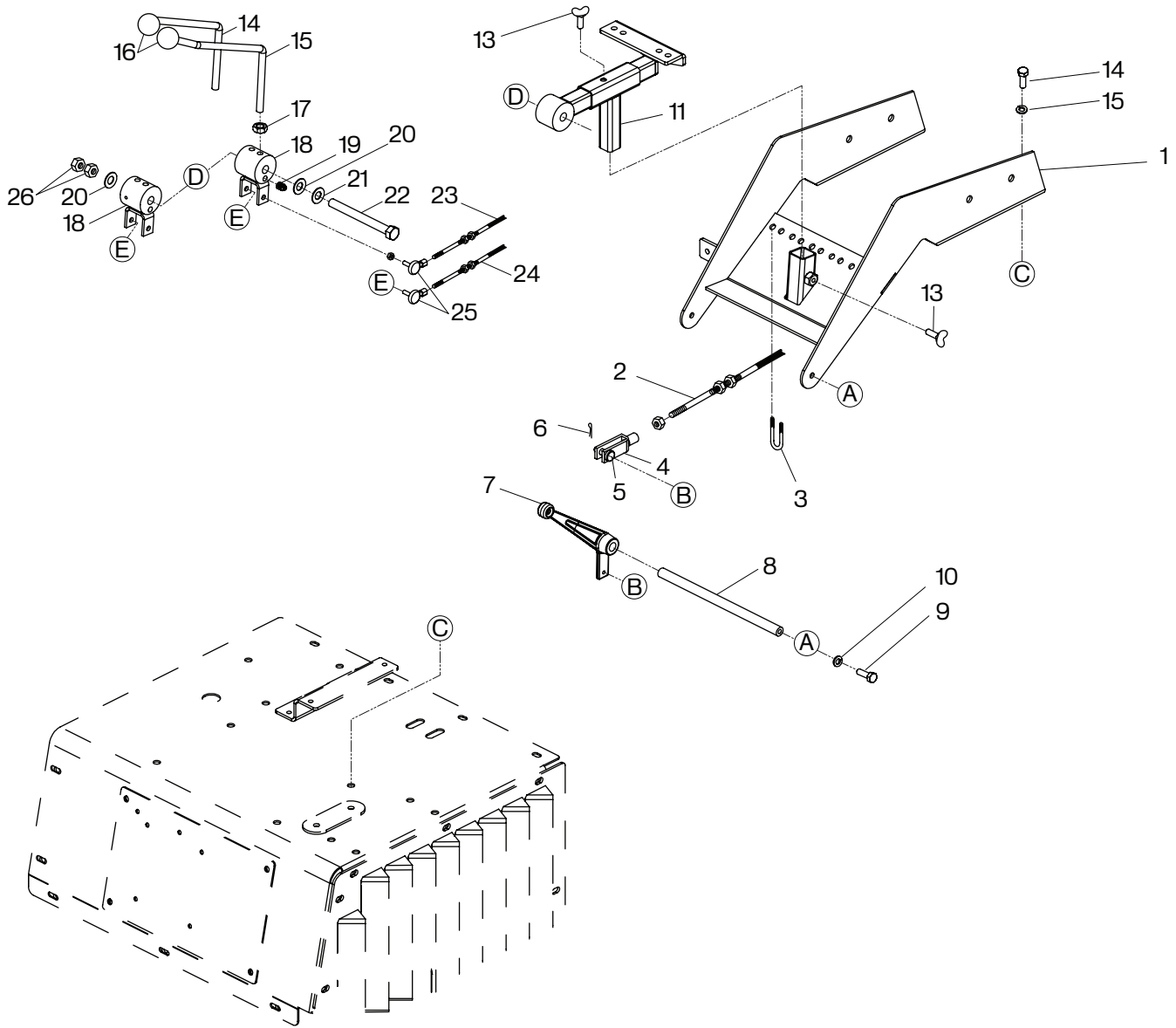

Figure 10-19

Controls - Right Side Low Deck Parts List

Item No.	Part Number	Qty.	Description	Remarks
1	1003168	1	Bracket, LD	
2	920136	6	Cable, Push Pull	
3	350060	1	U-Bolt, .375-16	
4	350050	8	Clevis, .250-28	
5	350080	8	Pin, Clevis, .250 x .875	
6	960019	8	Pin, Cotter, .094 x .750	
7	920210	6	Cast Handle, RH Control (Mod)	
8	988202	1	Rod, Control Handles, 12.00	
9	100-203-1A	2	CSHH, .375-24 x .750	
10	118-3	2	Washer, Lock, .375	Not Shown
11	1003113	1	W/M, RH Drive Controls	
13	920070	2	Thumb Screw, .375 -16 x 1.00	
14	920097L	1	Handle, Drive, LH	
15	920097R	1	Handle, Drive, RH	
16	920225	4	Knob, Round Ball, .500-13 x R1.875	
17	116-5-1	4	Nut, Jam, .500-13	
18	920094	2	RH Pivot, F/R Lever	
19	920095	2	Ball, Plunger, .500-13	
20	119-7	2	Washer, Flat, .625	
21	490080	1	Washer, Bevel, .625	
22	920229	1	CSHH, .625-11 x 7.50	
23	920130	2	Cable, RH Control	123" x 3" Stroke
24	920120	2	Cable, RH Drive, Auger and Pump	104" x 3" Stroke
25	920090	4	Spherical Rod End, w/ Stud	
26	116-7-1	2	Nut, Jam, .625-11	

Controls - Left Side

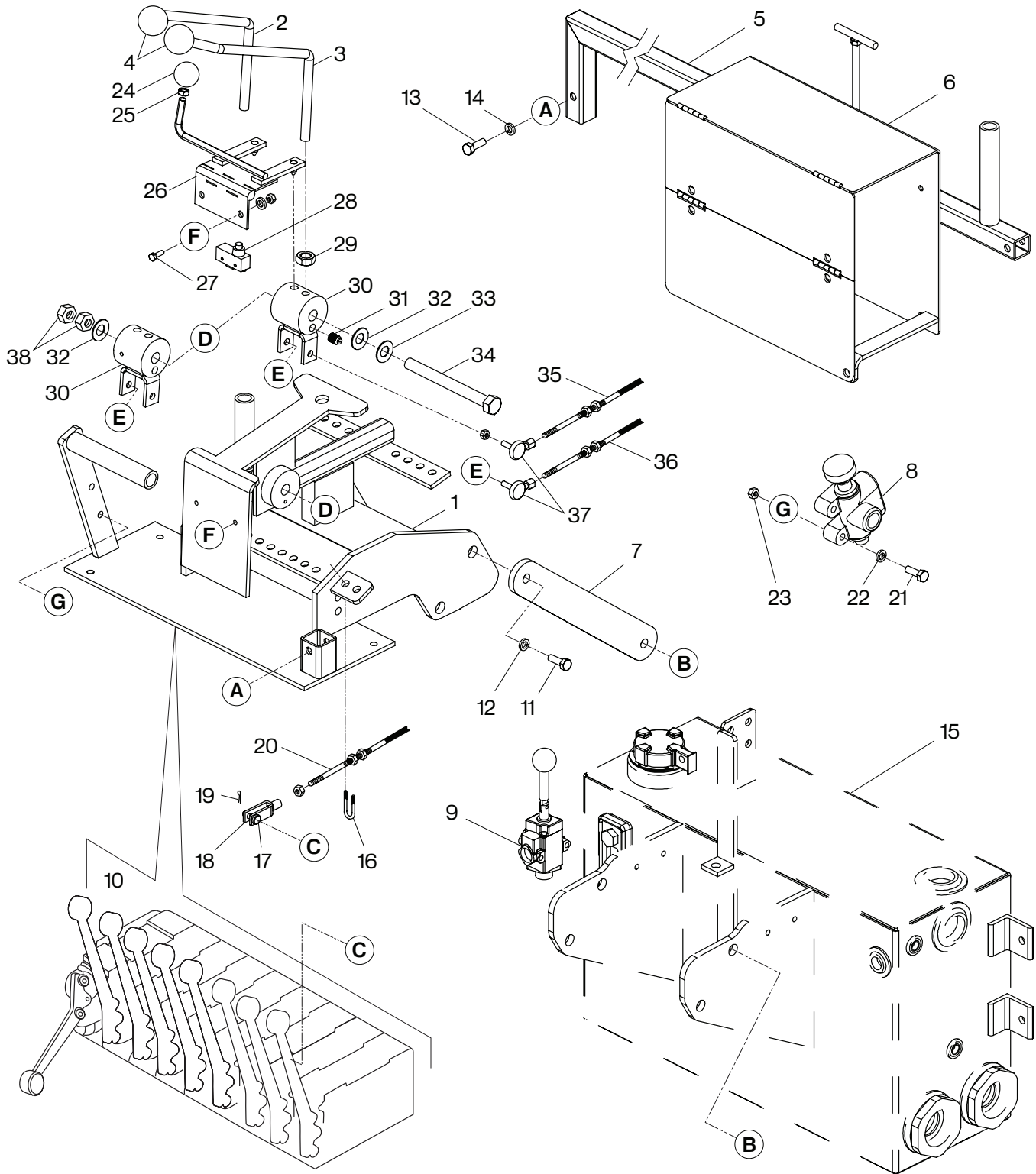

Figure 10-20

Controls - Left Side Parts List

Item No.	Part Number	Qty.	Description	Remarks
1	1003121	1	w/m, Left Controls M Drive	
2	920097L	1	Handle, Drive, LH	
3	920097R	1	Handle, Drive, RH	
4	920225	4	Knob, Round Ball, .500-13 x R1.875	
5	1003287	1	W/M Control Tube Support	
6	1002923	1	Vandalism Box Cover	
–	Reference	1	Instrument Panel Dash	
7	1003119	4	Linkage, Controls	
8	910080	1	Selector Valve, Vibrator	
9	910120	1	Selector Valve, Conveyor	
10	Reference	1	Main Valve Bank	see Figure 10-21
–	910054	6	Section, Valve (Cylinders) (Spring Return)	
–	910054FLS	1	Float, Assembly Screed	
–	910052	2	Section, Valve (Augers (Detented)	
–	910055	1	Inlet Cover, V-20 (w/Relief)	
–	910056	1	Outlet Cover, V-20 (w/PB Sleeve)	
11	102-606-1A	8	CSHH, .625-11 x 1.25 GR5	
12	118-7	8	Washer, Lock, .625	Reference Only
13	102-107-1A	2	CSHH, .312-18 x 1.50	
14	118-2	2	Washer, Lock, .312	
15	1003117	1	Assy, Tank, Hyd, Adj	
16	350060	1	U-Bolt, .375-16	
17	350080	8	Pin, Clevis, .250 x .875	
18	350050	8	Clevis, .250-28	
19	960019	8	Pin, Cotter, .094 x .750	
20	920136	6	Cable, Push Pull	
21	102-109-1A	2	CSHH, .312-18 x 2.00	
22	118-2	2	Washer, Lock, .312	
23	116-2	2	Nut, Hex, .312-18	
24	851156	1	Knob, Round Ball, .375-16 x R1.375	
25	116-3-1	1	Nut, Jam, .375-16	
26	900029	1	Bracket, Safety Switch	
27	102-3-1A	2	CSHH, .250-20 x .750	
28	900020	1	Switch, Neutral Safety	
29	116-5-1	4	Nut, Jam, .500-13	
30	920094	2	RH Pivot, F/R Lever	
31	920095	2	Ball Plunger, .500-13	
32	119-7	2	Washer, Flat, .625	

Controls - Left Side (continued)

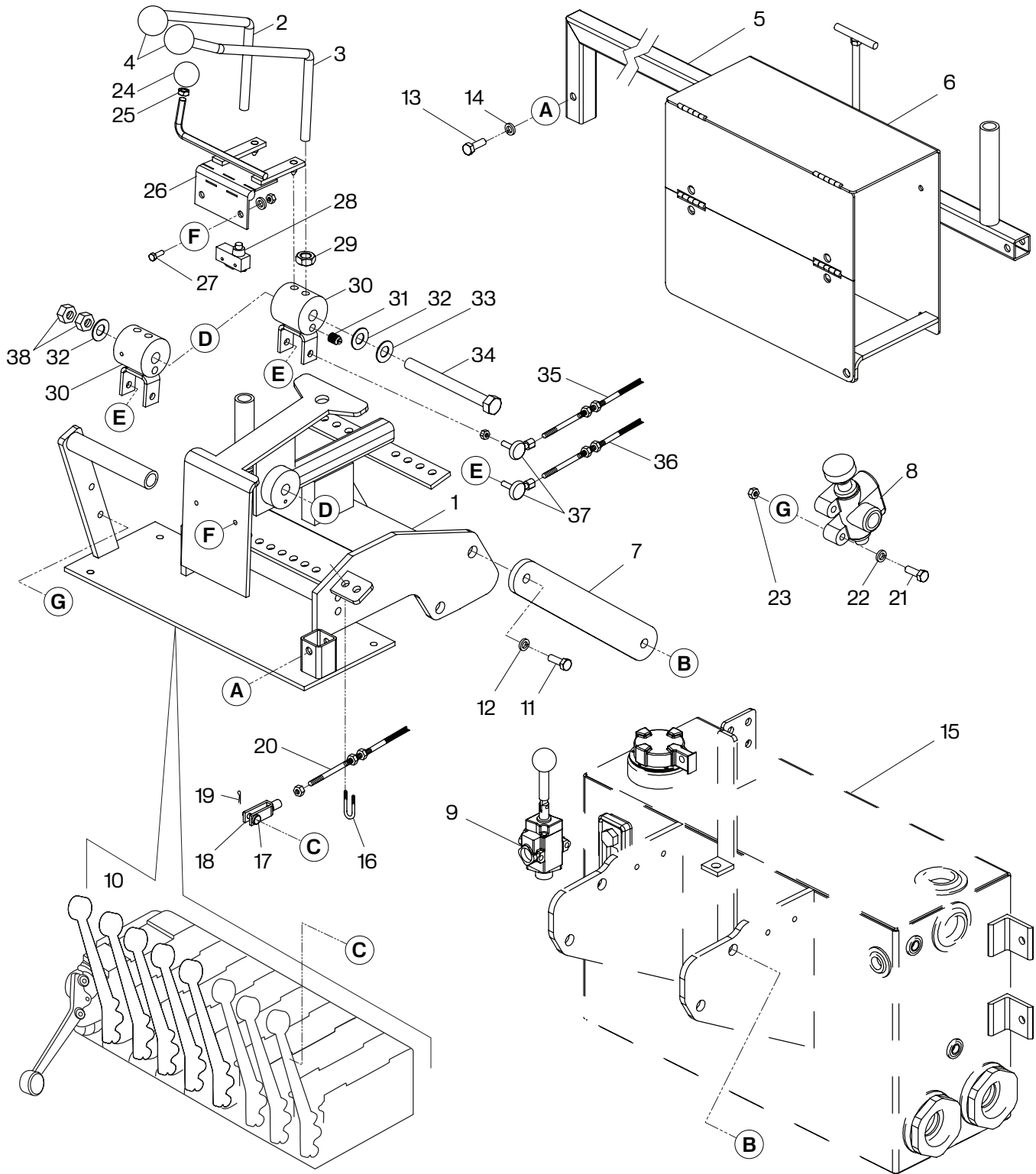

Figure 10-20

Controls - Left Side (continued) Parts List

Item No.	Part Number	Qty.	Description	Remarks
33	490080	1	Washer, Bevel, .625	
34	920229	1	CSHH, .625-11 x 7.50	
35	920130	2	Cable, RH Control	123" x 3" Stroke
36	920120	2	Cable, RH Drive, Auger and Pump	104" x 3" Stroke
37	920090	4	Spherical Rod End, w/ Stud	
38	116-7-1	2	Nut, Jam, .625-11	

Main Valve Manifold Detail

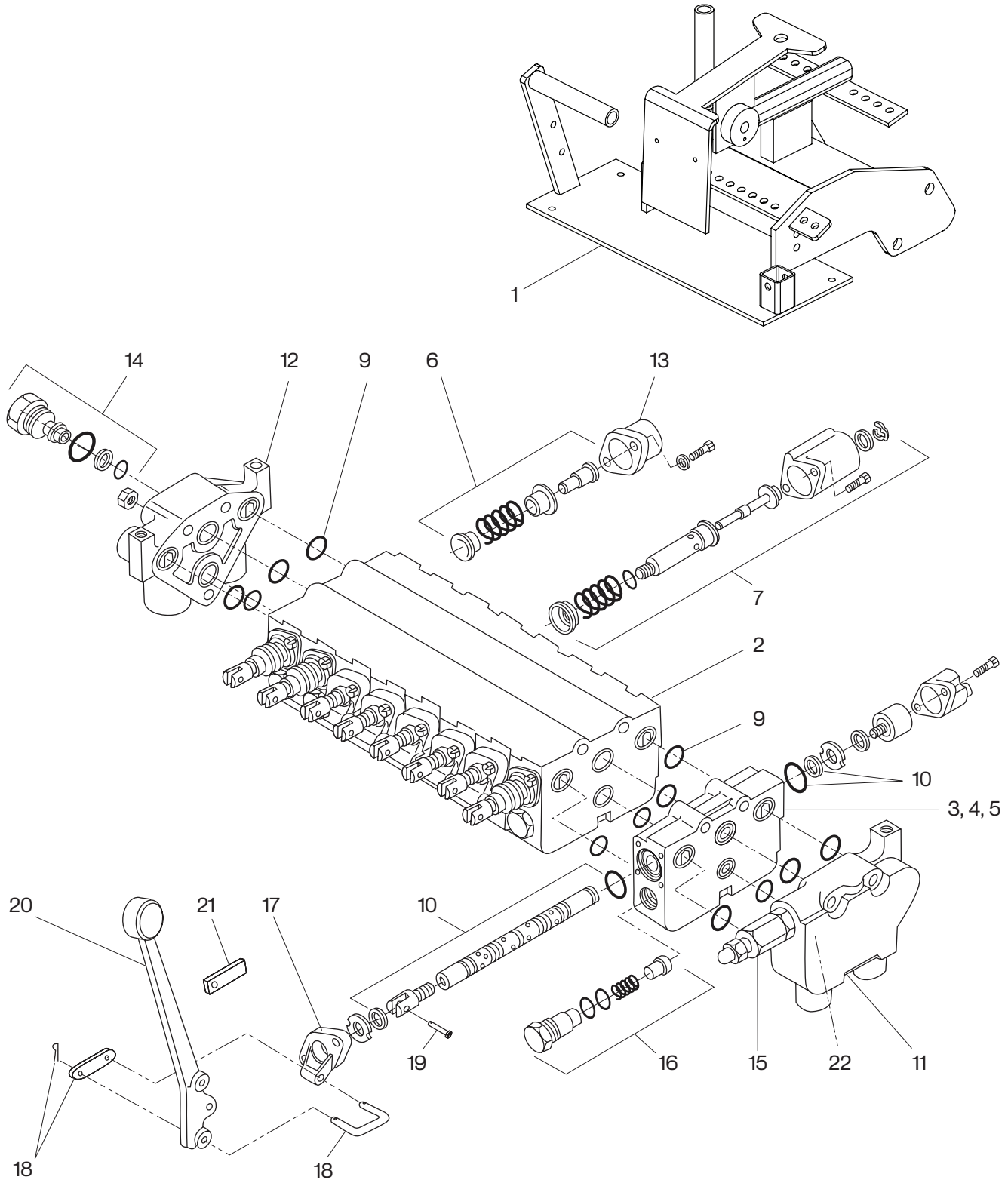

Figure 10-21

Main Valve Manifold Detail Parts List

Item No.	Part Number	Qty.	Description	Remarks
1	1003159	1	Mount, Main Valve, LH	
2	851161	1	Valve Assy, 9 Section, w/Float	
3	910054	6	Valve Section, Spring Return	
4	910052	2	Valve Section, Detented	
5	910054FLS	1	Valve Section, Float	
6	901014	6	Spring Center Kit	
7	141050	1	Float Positioner Kit	
8	901007	2	Detent Kit	
9	910062	10	Seal Kit, Valve Section	
10	910059	9	Seal Kit, Valve Spool	
–	910065	A/R	Seal Kit, Relief Valve	Not Shown
11	910055	1	Cover, Valve Inlet	
12	910056	1	Cover, Valve Outlet	
13	141040	9	Cap, Valve Spool Cover	
14	901002	1	Power Beyond Sleeve	
15	901009	1	Valve, Main Relief	
16	141020	9	Valve & Plug, Anticavitation	
17	910058	1	Bracket, Valve Lever Mount	
18	901010	9	Link Assy, Valve Lever	
19	350080	9	Pin, Clevis	
20	910060	9	Handle, Vertical	
21	852648	9	Tab, Auger Valve Reverse Lockout	
22	72371	1	FITT, Test 04MP-02PD	

Kubota Sheet Metal Cover - High Deck

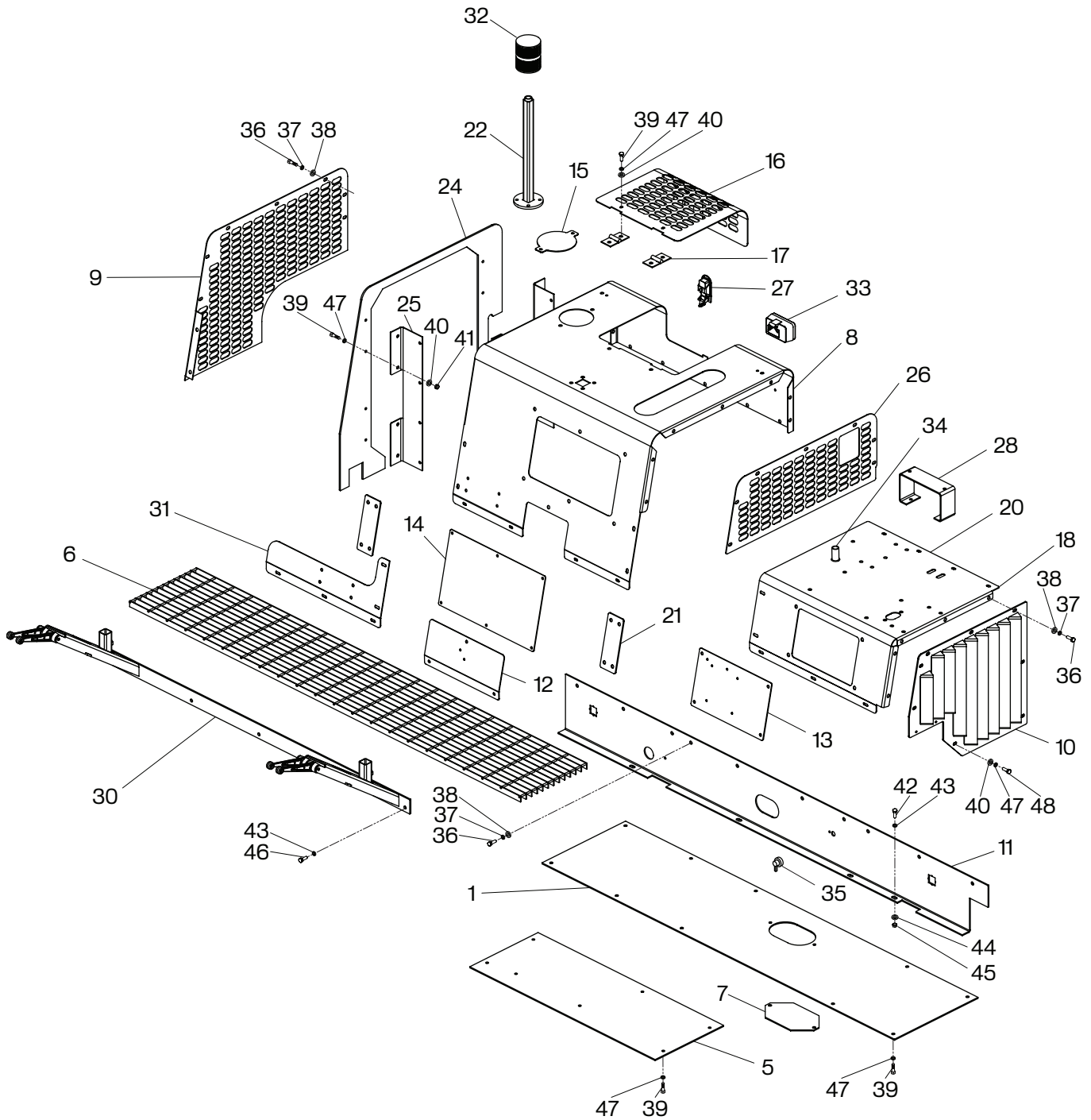

Figure 10-22

Kubota Sheet Metal Cover - High Deck Parts List

Item No.	Part Number	Qty.	Description	Remarks
1	853645	1	Plate, Conveyor Flap	
2	853654	1	Bracket, Floor Board Mount	
5	853669	1	Plate, Bottom Engine	
6	853823	1	Grating, Walkboard	
7	980751	1	Plate, Cover	
8	987627	1	Cover, Top Center	
9	988208	1	Grill, Top Center	
10	1000850	1	W/M, RH Engine Cover, w/Defl	
11	988115	1	Toeboard	
12	988117	1	Engine Cover	
13	987633	1	Cover, Access Hole RH	
14	987629	1	Cover, Access Hole, Top	
15	987635	1	Radiator Cover	
16	987626	1	Door, Engine Access	
17	987639	2	Hinge, (2) Thru Holes	
18	988118	1	Cover, Right Side SM	
20	988218	1	Bar Right Hood Support	
21	988226	2	Bracket For SM	
22	989469SRV	1	Assy, Beacon Light Post	
23	980642	1	Angle, 2.00 x 2.00 x .250	
24	987630	1	Shroud	
25	987632	2	Flange, Shroud	
26	1003306	1	Grill, Top Center	
27	980460	1	Lever, Fastener	
-	35560	2	Key, Vandalism Cover	
28	988124	1	Bracket, Air Breather, Kubota	
30	1003132	1	Assy, Tail Piece	
-	920120	4	Cable, Lower Controls	Not Shown
-	920210A	4	Cast Handle, Lower Control	Not Shown
31	988116	1	SM Driver Side	
32	211748-02	1	Strobe Light, Amber	
33	160040A	2	Work Light	
34	985518	1	Term. Battery, POS. Remote Mount	
-	986804	1	Cable, Battery	Battery Post to Jump Start Post
-	986806	1	Battery, 12V, 1125 CCA	Not Available, buy locally
-	5804	1	Cable, Battery	Switch to Bat. Neg or Gnd Post
35	SW29	1	Switch, Battery Disconnect	
36	102-105-1A	A/R	CSHH, .312-18 x 1.00	

Kubota Sheet Metal Cover - High Deck (continued)

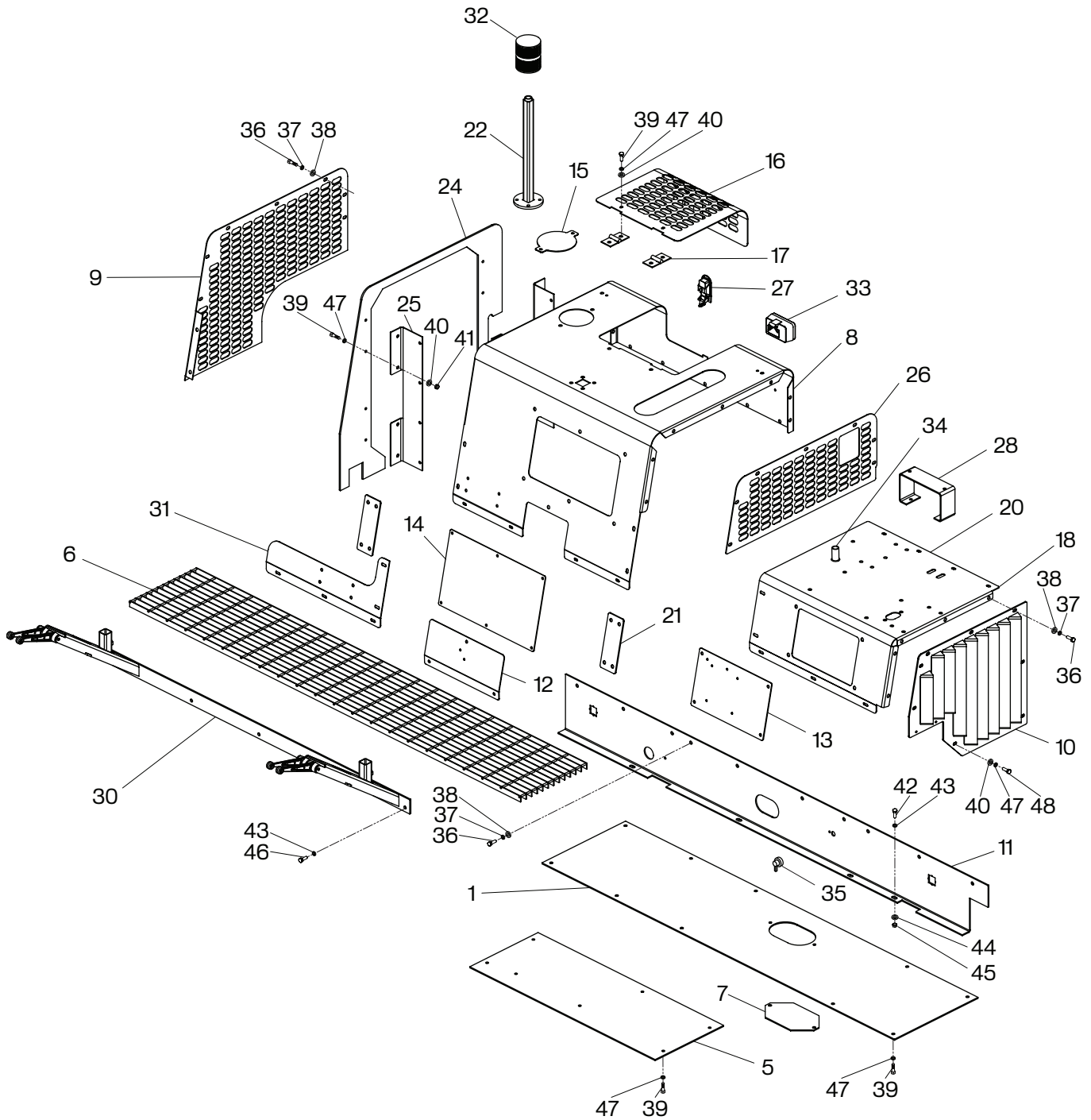

Figure 10-22

Kubota Sheet Metal Cover - High Deck (continued) Parts List

Item No.	Part Number	Qty.	Description	Remarks
37	118-2	A/R	Washer, Lock, .312	
38	120-2	A/R	Washer, Flat, .312	
39	102-205-1A	A/R	CSHH, .375-16 x 1.00	
40	120-3	A/R	Washer, Flat, .375	
41	143-3	A/R	Nut, Lock, .375	
42	102-409-1A	A/R	CSHH, .500-13 x 2.00	
43	119-5	A/R	Washer, Flat, .500	
44	118-5	A/R	Washer, Lock, .500	
45	116-5	A/R	Nut, Hex, .500-13	
46	102-406-1A	A/R	CSHH, .500-13 x 1.25	
47	118-3	A/R	Washer, Lock, .375	
48	100-205-1A	A/R	CSHH, .375-28 x 1.00	

Kubota Sheet Metal Cover - Low Deck

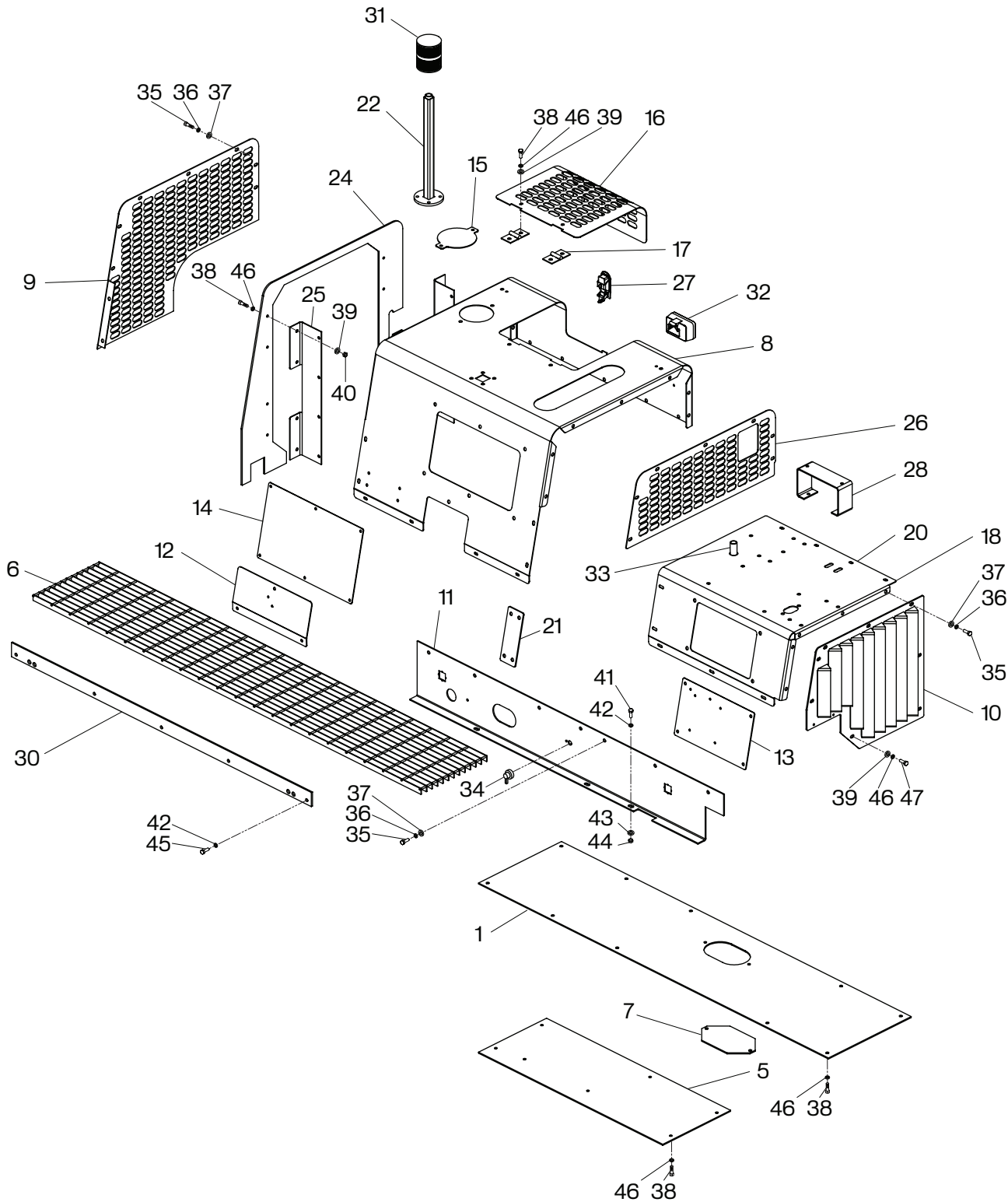

Figure 10-23

Kubota Sheet Metal Cover - Low Deck Parts List

Item No.	Part Number	Qty.	Description	Remarks
1	853645	1	Plate, Conveyor Flap	
2	853654	1	Bracket, Floor Board Mount	
5	853669	1	Plate, Bottom Engine	
6	853823	1	Grating, Walkboard	
7	980751	1	Plate, Cover	
8	987627	1	Cover, Top Center	
9	988208	1	Grill, Top Center	
10	1000850	1	W/M, RH Engine Cover, w/Defl	
11	988189	1	Toeboard	
12	988117	1	Engine Cover	
13	987633	1	Cover, Access Hole RH	
14	987629	1	Cover, Access Hole, Top	
15	987635	1	Radiator Cover	
16	987626	1	Door, Engine Access	
17	987639	2	Hinge, (2) Thru Holes	
18	988118	1	Cover, Right Side SM	
20	988218	1	Bar Right Hood Support	
21	988226	1	Bracket For SM	
22	989469SRV	1	Assy, Beacon Light Post	
23	980642	1	Angle, 2.00 x 2.00 x .250	
24	987630	1	Shroud	
25	987632	2	Flange, Shroud	
26	1003306	1	Grill, Top Center	
27	980460	1	Lever, Fastener	
-	35560	2	Key, Vandalism Cover	
28	988124	1	Bracket, Air Breather, Kubota	
30	1003240	1	Tail, Piece Bolt On	
31	211748-02	1	Strobe Light, Amber	
32	160040A	2	Work Light	
33	985518	1	Term. Battery, POS. Remote Mount	
-	986804	1	Cable, Battery	Battery Post to Jump Start Post
-	986806	1	Battery, 12V, 1125 CCA	Not Available, buy locally
-	5804	1	Cable, Battery	Switch to Bat. Neg or Gnd Post
34	SW29	1	Switch, Battery Disconnect	
35	102-105-1A	A/R	CSHH, .312-18 x 1.00	
36	118-2	A/R	Washer, Lock, .312	
37	120-2	A/R	Washer, Flat, .312	
38	102-205-1A	A/R	CSHH, .375-16 x 1.00	

Kubota Sheet Metal Cover - Low Deck (continued)

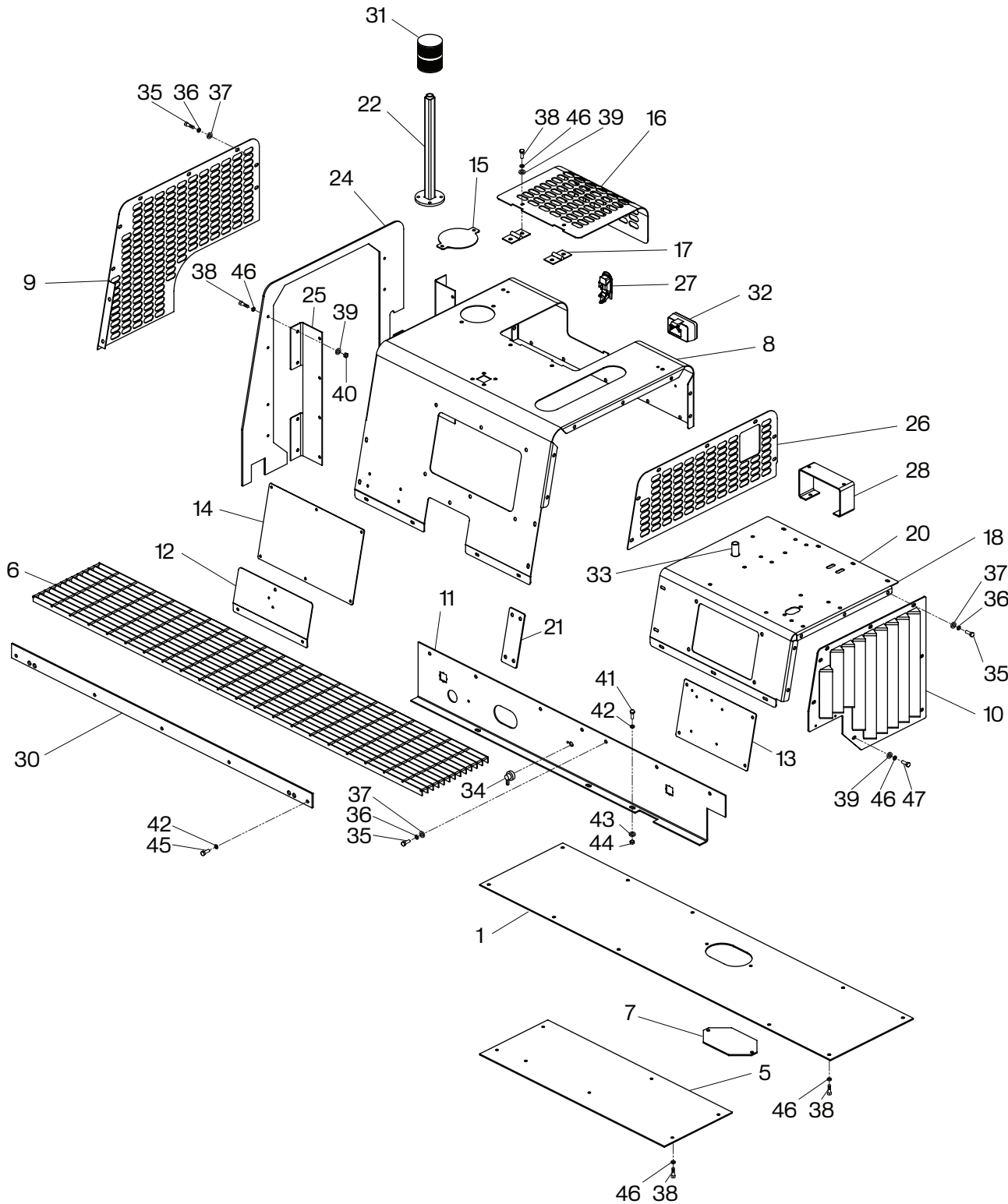

Figure 10-23

Kubota Sheet Metal Cover - Low Deck (continued) Parts List

Item No.	Part Number	Qty.	Description	Remarks
39	120-3	A/R	Washer, Flat, .375	
40	143-3	A/R	Nut, Lock, .375	
41	102-409-1A	A/R	CSHH, .500-13 x 2.00	
42	119-5	A/R	Washer, Flat, .500	
43	118-5	A/R	Washer, Lock, .500	
44	116-5	A/R	Nut, Hex, .500-13	
45	102-406-1A	A/R	CSHH, .500-13 x 1.25	
46	118-3	A/R	Washer, Lock, .375	
47	100-205-1A	A/R	CSHH, .375-28 x 1.00	

CAT Sheet Metal Cover - High Deck

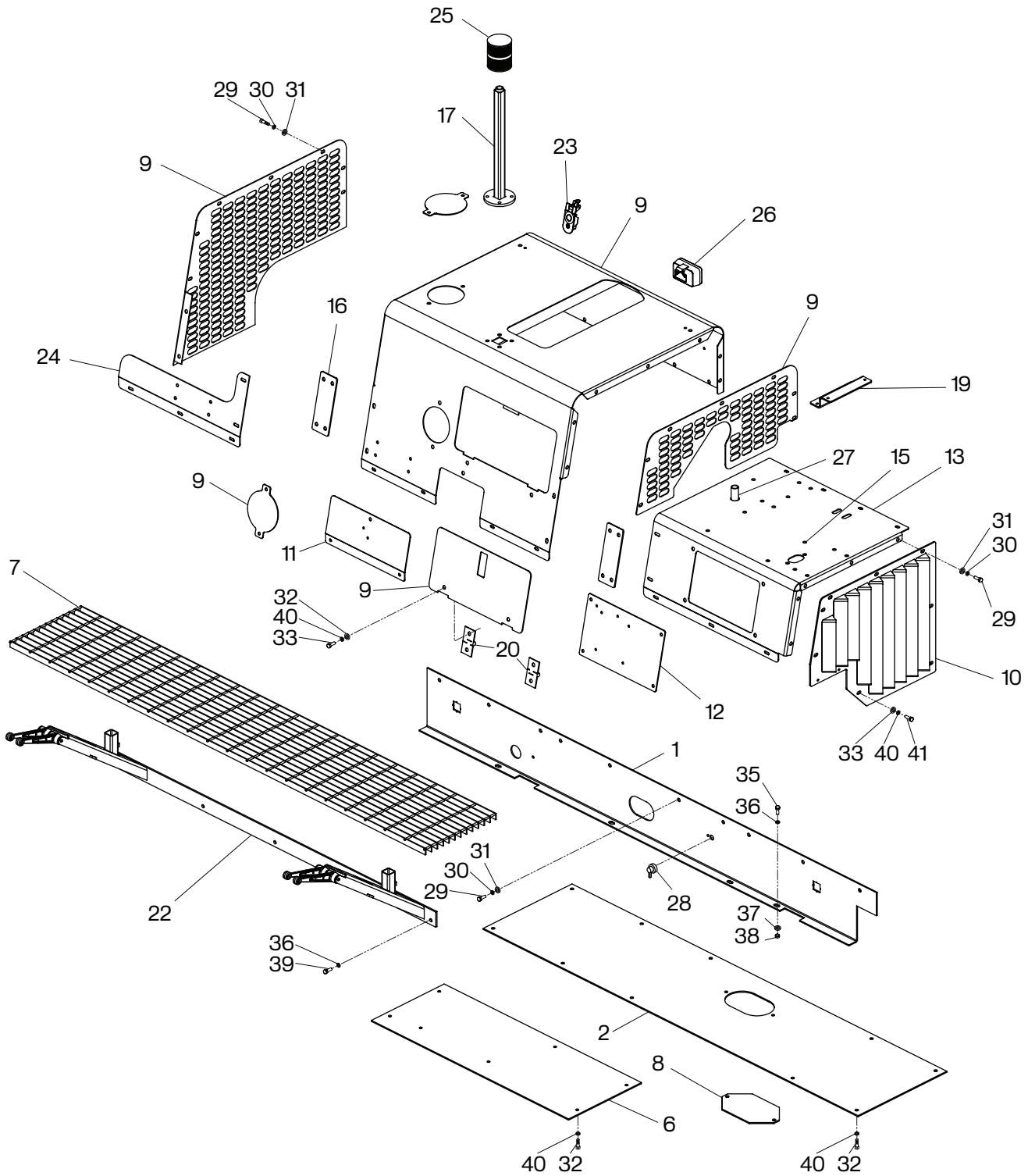

Figure 10-24

CAT Sheet Metal Cover - High Deck Parts List

Item No.	Part Number	Qty.	Description	Remarks
1	988115	1	Toeboard	
2	853645	1	Plate, Conveyor Flap	
3	853654	1	Bracket, Floor Board Mount	
6	853669	1	Plate, Bottom Engine	
7	853823	1	Grating, Walkboard	
8	980751	1	Plate, Cover	
9	1003309	1	Assy, Engine Cover, CAT	
10	1000850	1	W/M, RH Engine Cover, W/Defl	
11	988117	1	Engine Cover	
12	987633	1	Cover, Access Hole RH	
13	988118	1	Cover, Right Side SM	
15	988218	1	Bar Right Hood Support	
16	988226	1	Bracket For SM	
17	989469SRV	1	Assy, Beacon Light Post	
18	980642	1	Angle, 2.00 x 2.00 x .250	
19	1002924	1	Plate, Air Cleaner Mount	
20	987639	1	Hinge, (2) Thru Holes	
22	1003132	1	Assy, Tail Piece	
-	920120	4	Cable, Lower Controls	Not Shown
-	920210A	4	Cast Handle, Lower Control	Not Shown
23	980460	1	Lever, Fastener	
-	35560	2	Key, Vandalism Cover	
24	988116	1	SM Driver Side	
25	211748-02	1	Strobe Light, Amber	
26	160040A	2	Work Light	
27	985518	1	Term. Battery, POS. Remote Mount	
-	986804	1	Cable, Battery	Battery Post to Jump Start Post
-	986806	1	Battery, 12V, 1125 CCA	Not Available, buy locally
-	5804	1	Cable, Battery	Switch to Bat. Neg or Gnd Post
28	SW29	1	Switch, Battery Disconnect	
29	102-105-1A	A/R	CSHH, .312-18 x 1.00	
30	118-2	A/R	Washer, Lock, .312	
31	120-2	A/R	Washer, Flat, .312	
32	102-205-1A	A/R	CSHH, .375-16 x 1.00	
33	120-3	A/R	Washer, Flat, .375	
34	143-3	A/R	Nut, Lock, .375	
35	102-409-1A	A/R	CSHH, .500-13 x 2.00	
36	119-5	A/R	Washer, Flat, .500	

CAT Sheet Metal Cover - High Deck (continued)

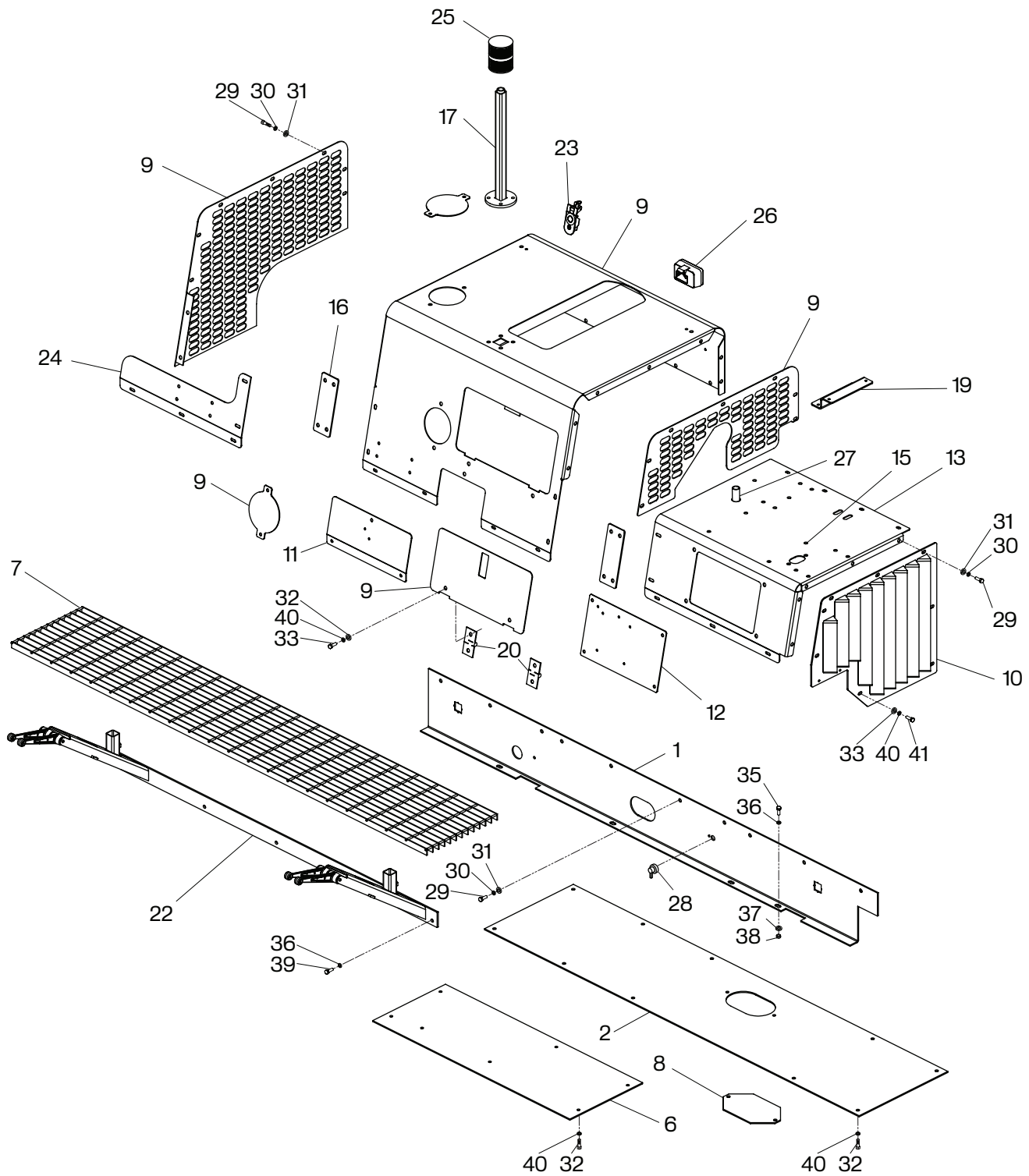
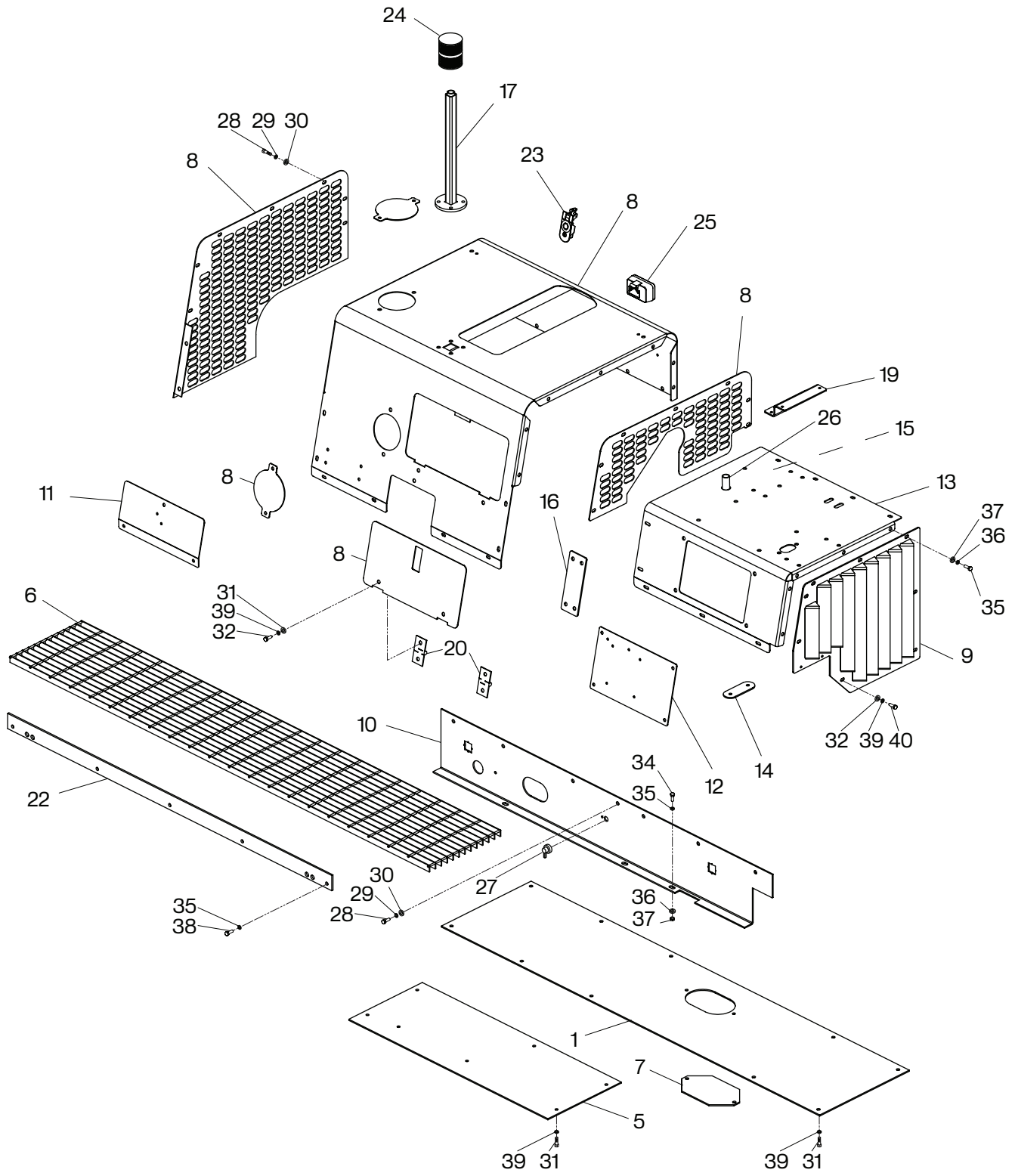

Figure 10-24

CAT Sheet Metal Cover - High Deck (continued) Parts List

Item No.	Part Number	Qty.	Description	Remarks
37	118-5	A/R	Washer, Lock, .500	
38	116-5	A/R	Nut, Hex, .500-13	
39	102-406-1A	A/R	CSHH, .500-13 x 1.25	
40	118-3	A/R	Washer, Lock, .375	
41	100-205-1A	A/R	CSHH, .375-28 x 1.00	

CAT Sheet Metal Cover - Low Deck



August

Figure 10-25

CAT Sheet Metal Cover - Low Deck Parts List

Item No.	Part Number	Qty.	Description	Remarks
1	853645	1	Plate, Conveyor Flap	
2	853654	1	Bracket, Floor Board Mount	
5	853669	1	Plate, Bottom Engine	
6	853823	1	Grating, Walkboard	
7	980751	1	Plate, Cover	
8	1003309	1	Assy, Engine Cover, CAT	
9	1000850	1	W/M, RH Engine Cover, W/Defl	
10	988189	1	Toeboard	
11	988117	1	Engine Cover	
12	987633	1	Cover, Access Hole RH	
13	988118	1	Cover, Right Side SM	
14	988126	1	Cover, Top Con Hole	
15	988218	1	Bar Right Hood Support	
16	988226	1	Bracket For SM	
17	989469SRV	1	Assy, Beacon Light Post	
18	980642	1	Angle, 2.00 x 2.00 x .250	
19	1002924	1	Plate, Air Cleaner Mount	
20	987639	2	Hinge, (2) Thru Holes	
22	1003240	1	Tail Piece Bolt On	
23	980460	1	Lever, Fastener	
-	35560	2	Key, Vandalism Cover	
24	211748-02	1	Strobe Light, Amber	
25	160040A	2	Work Light	
26	985518	1	Term. Battery, POS. Remote Mount	
-	986804	1	Cable, Battery	Battery Post to Jump Start Post
-	986806	1	Battery, 12V, 1125 CCA	Not Available, buy locally
-	5804	1	Cable, Battery	Switch to Bat. Neg or Gnd Post
27	SW29	1	Switch, Battery Disconnect	
28	102-105-1A	A/R	CSHH, .312-18 x 1.00	
29	118-2	A/R	Washer, Lock, .312	
30	120-2	A/R	Washer, Flat, .312	
31	102-205-1A	A/R	CSHH, .375-16 x 1.00	
32	120-3	A/R	Washer, Flat, .375	
33	143-3	A/R	Nut, Lock, .375	
34	102-409-1A	A/R	CSHH, .500-13 x 2.00	
35	119-5	A/R	Washer, Flat, .500	
36	118-5	A/R	Washer, Lock, .500	
37	116-5	A/R	Nut, Hex, .500-13	

t, 2009

CAT Sheet Metal Cover - Low Deck (continued)

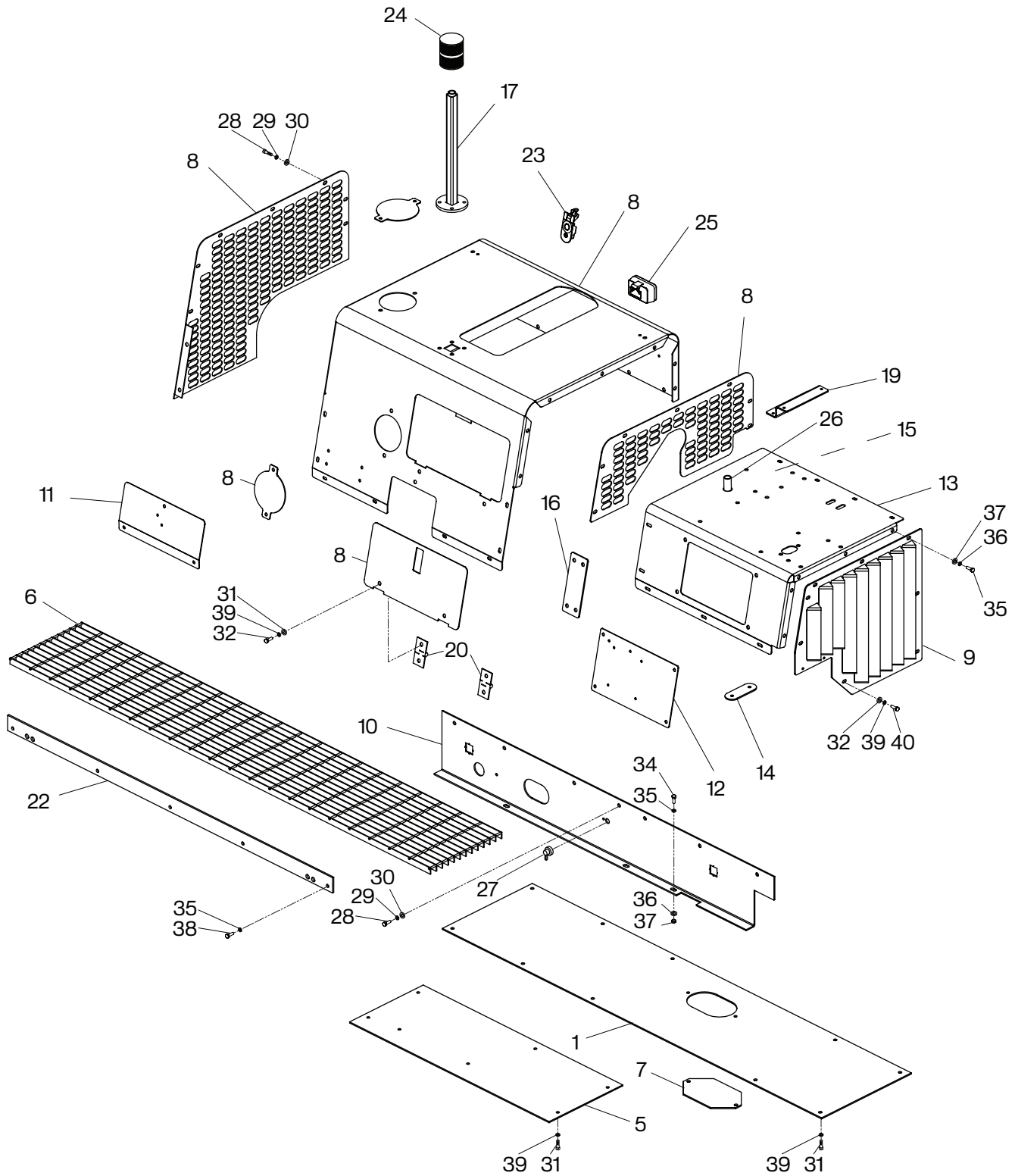

Figure 10-25

CAT Sheet Metal Cover - Low Deck (continued) Parts List

Item No.	Part Number	Qty.	Description	Remarks
38	102-406-1A	A/R	CSHH, .500-13 x 1.25	
39	118-3	A/R	Washer, Lock .375	
40	100-205-1A	A/R	CSHH, .375-28 x 1.00	

Strike Offs And Extensions

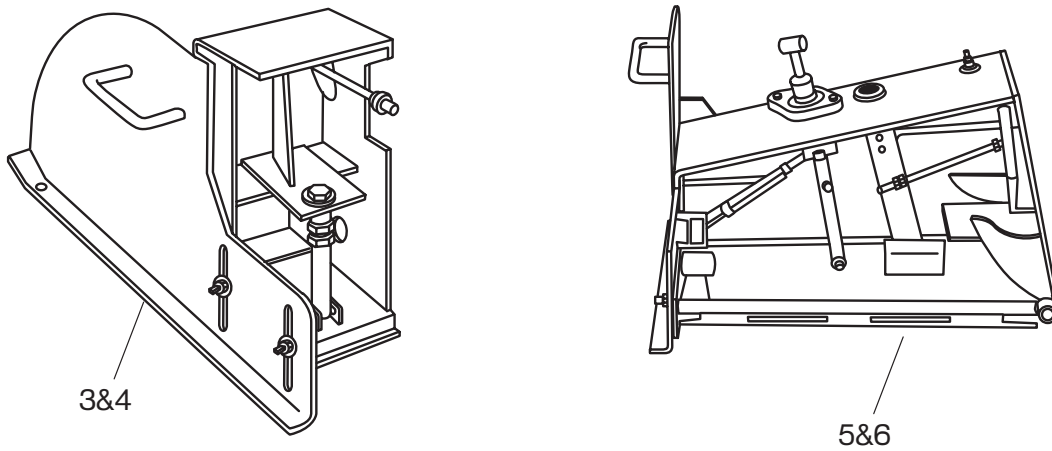
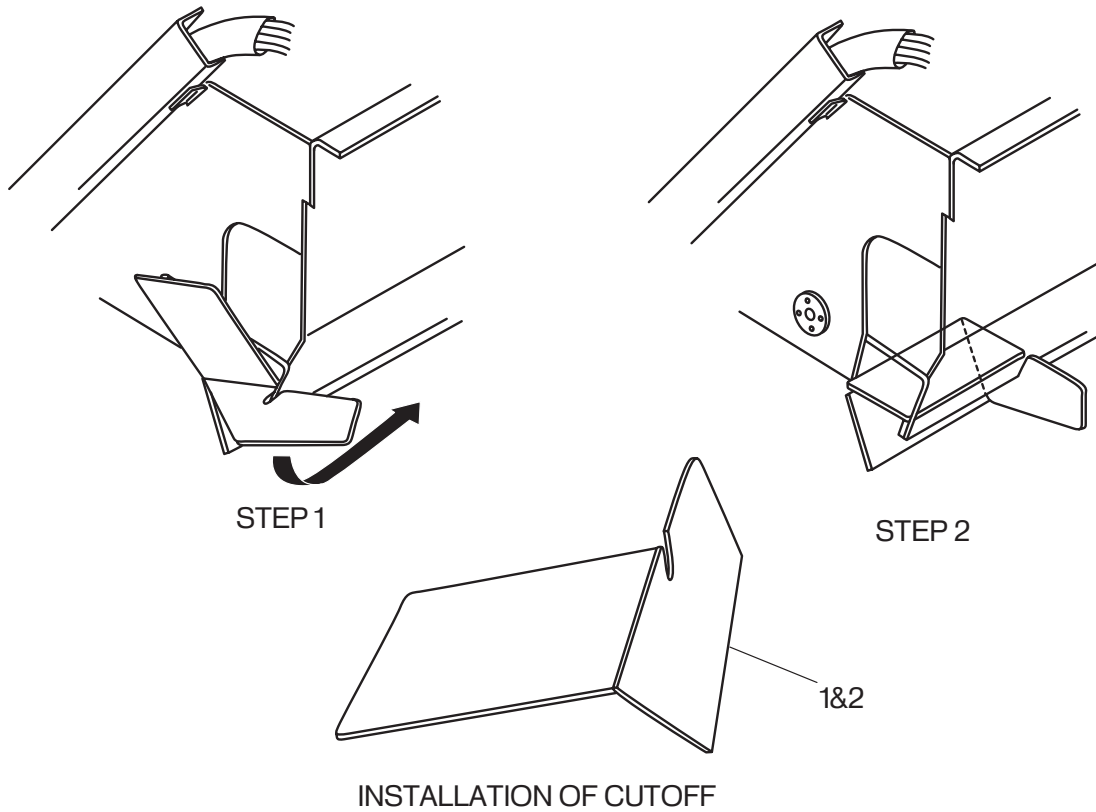

Figure 10-26

Strike Offs And Extensions Parts List

Item No.	Part Number	Qty.	Description	Remarks
1	860091LSRV	A/R	Strike Off, Left Side, 12"	
2	860091RSRV	A/R	Strike Off, Right Side, 12"	
1	860095LSRV	A/R	Strike Off, Left Side, 24"	
2	860095RSRV	A/R	Strike Off, Right Side, 24"	
3	851634LSRV	A/R	Extension, 6' Left Side	
4	851634RSRV	A/R	Extension, 6' Right Side	
5	851635LSRV	A/R	Roll Up Curb Attachment, Left Side, 12"	
6	851635RSRV	A/R	Roll Up Curb Attachment, Right Side, 12"	
5	851636LSRV	A/R	Roll Up Curb Attachment, Left Side, 24"	Standard
6	851636RSRV	A/R	Roll Up Curb Attachment, Right Side, 24"	Standard

Instrument Panel Dash - Controls and Gauges

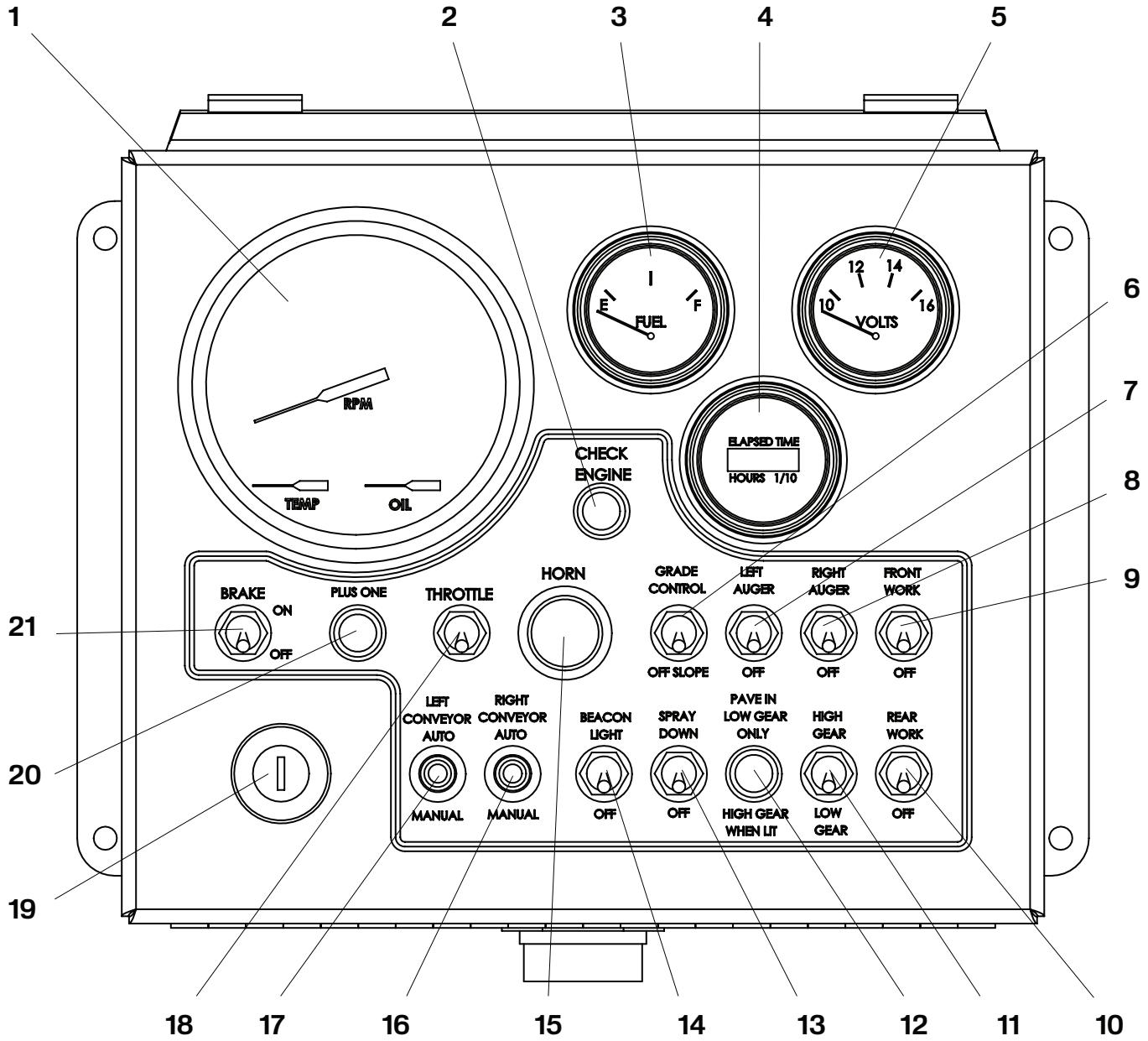

Figure 10-27

Instrument Panel Dash - Controls and Gauges Parts List

Item No.	Part Number	Qty.	Description	Remarks
1	1002032	1	Gauge, 3 in 1: Tach, Oil, Water Temp	LH Auto Augers
2	31983	1	Light, Red, Dash, .500 Hole	
3	1002033	1	Fuel Gauge	
4	1002034	1	Volts Gauge	
5	1002035	1	Hourmeter Gauge	
6	851391	1	Switch, Toggle, SPST, 2-POS	
7	851391	1	Switch, Toggle, SPST, 2-POS	
8	851391	1	Switch, Toggle, SPST, 2-POS	
9	851391	1	Switch, Toggle, SPST, 2-POS	
10	851391	1	Switch, Toggle, SPST, 2-POS	
11	851391	1	Switch, Toggle, SPST, 2-POS	
12	39146-14	1	Ignition Switch w/Heat Start	
13	851391	1	Switch, Toggle, SPST, 2-POS	
14	851391	1	Switch, Toggle, SPST, 2-POS	
15	982249	1	Switch, Push Button	
16	900030	2	Switch, Toggle	
17	900030	2	Switch, Toggle	
18	900080	1	Switch, Toggle, 3-Pos, Rev-DPDT, MOM	
19	39146-14	1	Ignition Switch w/Heat Start	
—	982008-04	2	Ignition Key, Replacement	Not Shown
20	31985	1	Light, Green, Dash, .500 Hole	
21	851391	1	Switch, Toggle, SPST, 2-POS	

Instrument Panel Dash - Relays and Fuses

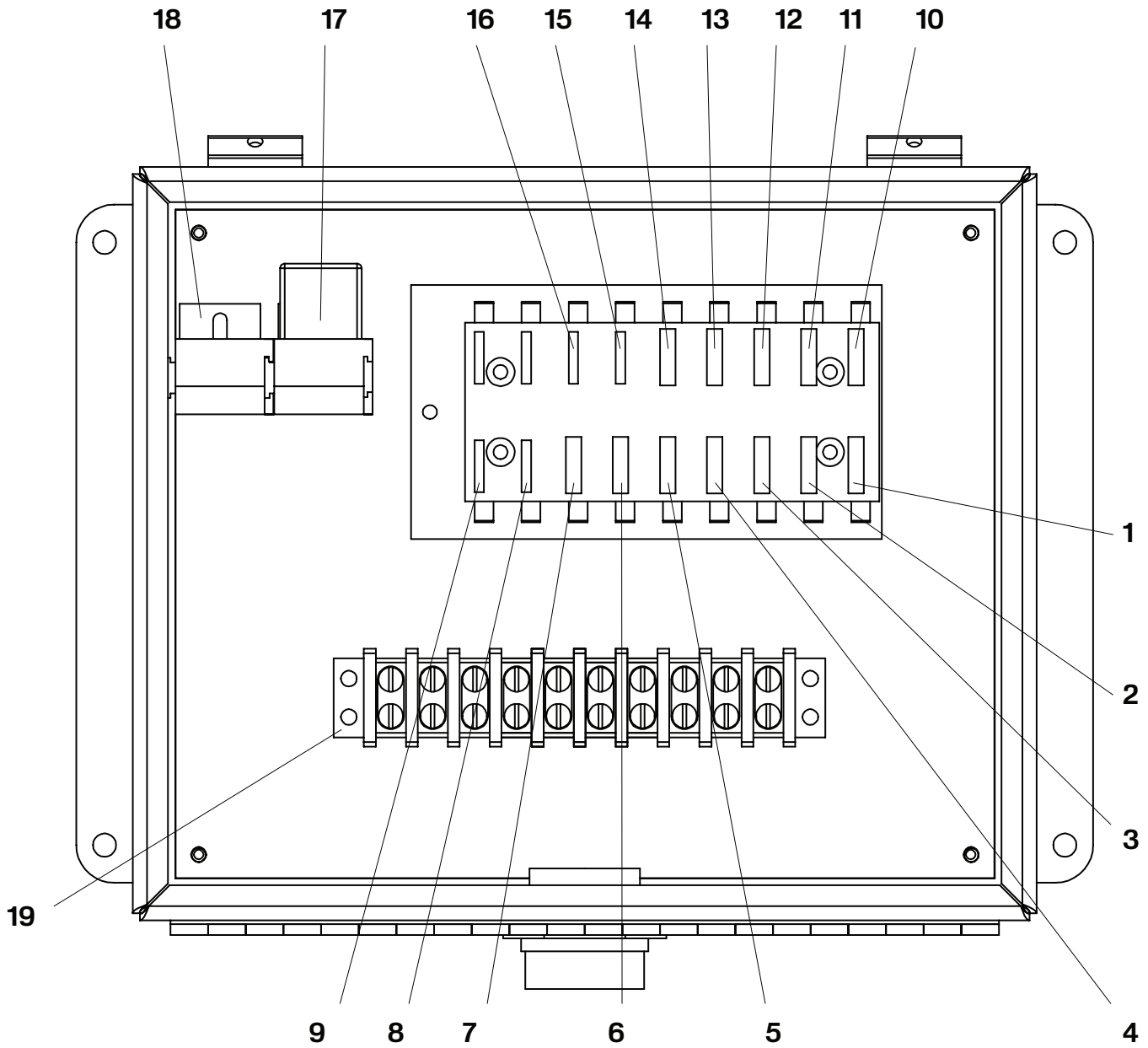

Figure 10-28

Instrument Panel Dash - Relays and Fuses Parts List

Item No.	Part Number	Qty.	Description	Remarks
1	36342	1	Fuse, 20 Amp, ATC	Gauges
2	36342	1	Fuse, 20 Amp, ATC	Beacon
3	36342	1	Fuse, 20 Amp, ATC	Right Conveyor
4	36342	1	Fuse, 20 Amp, ATC	Left Conveyor
5	36342	1	Fuse, 20 Amp, ATC	Auger & Horn
6	36746	1	Fuse, 5 Amp, ATC	Engine Enable
7	37303	1	Fuse, 25 Amp, ATC	Vibrator Relay
8	36342	1	Fuse, 20 Amp, ATC	Backup Alarm
9	36342	1	Fuse, 20 Amp, ATC	Pause Switch
10	36342	1	Fuse, 20 Amp, ATC	Work Lights
11	36342	1	Fuse, 20 Amp, ATC	2 Speed
12	36342	1	Fuse, 20 Amp, ATC	Spray Down Pump & Throttle
13	36342	1	Fuse, 20 Amp, ATC	Ignition Switch
14	36342	1	Fuse, 20 Amp, ATC	Generator
15	36342	1	Fuse, 20 Amp, ATC	Electric Steer
16	36342	1	Fuse, 20 Amp, ATC	Slope Control
17	36085	2	Relay, 12VDC, SPDT, 40 Amp, 5 Pin	Not All Quantity Shown
18	36086	2	Bracket, Relay Mount	Not All Quantity Shown
19	987982	1	Terminal Block, 10 Gang	

Screed Non-sloping Overview

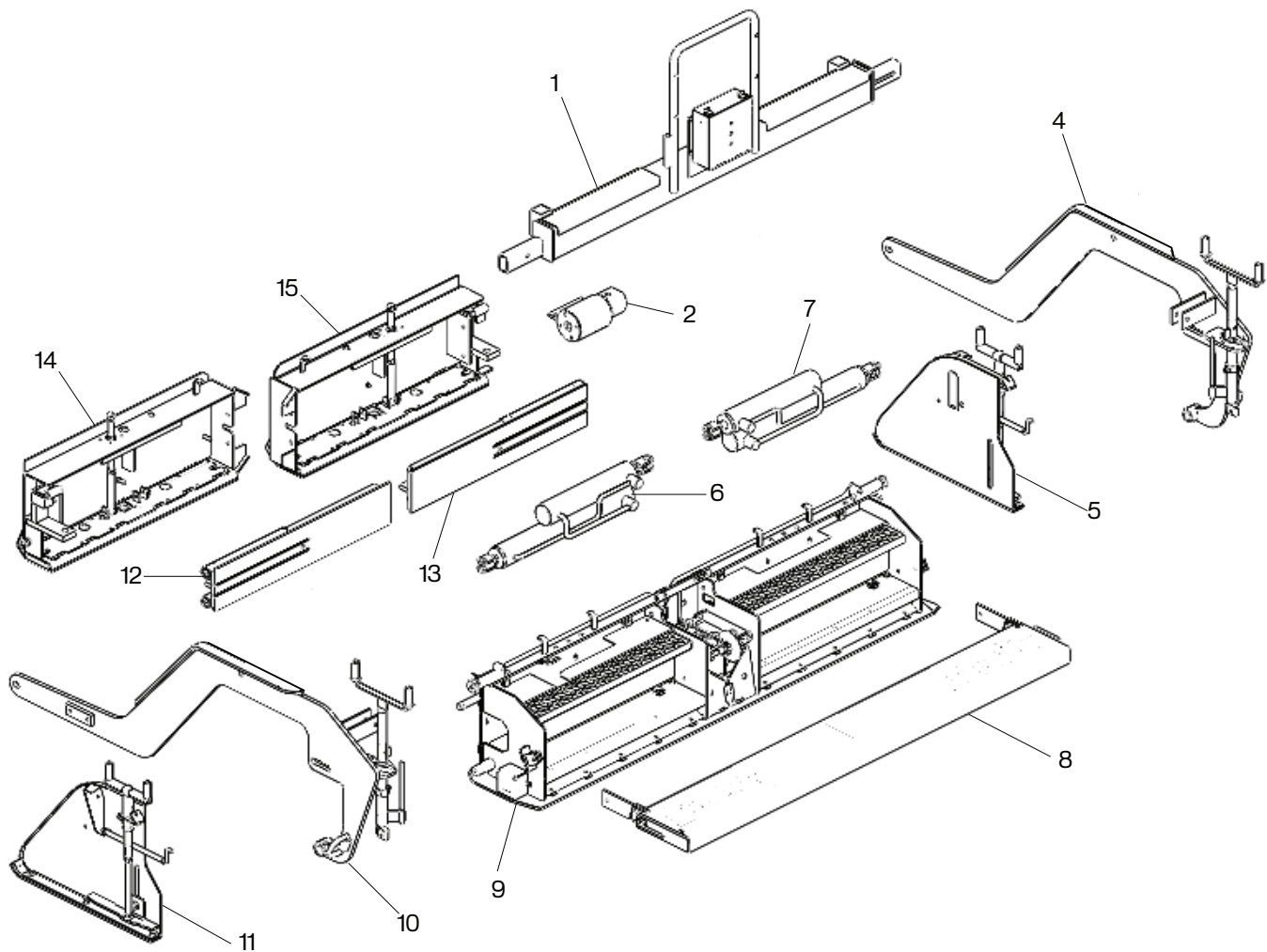

Figure 10-29

Screed Non-sloping Overview Parts List

Item No.	Ref. Figure	Description	Remarks
1	10-49	Screed Citrus Tank and Electric Heat Control Box	
2	10-37	Screed Vibrator Assembly	
4	10-48	Screed Pull Arm and Remote Control Box RH	
5	10-46	Screed Endgate Assembly RH	
6	10-50	Screed Miscellaneous Components	
7	10-51	Screed Miscellaneous Components	
8	10-39	Screed Walk Board Assembly	
9	10-29	Screed Frame Non-Sloping	See 10-35 for Electric
10	10-47	Screed Pull Arm and Remote Control Box LH	
11	10-45	Screed Endgate Assembly LH	
12	10-40	Screed Slide Plate Assembly	
13	10-40	Screed Slide Plate Assembly	
14	10-31	Screed Extension Single Adjuster LH	See 10-41 for Electric
15	10-32	Screed Extension Single Adjuster RH	See 10-42 for Electric

Screed Frame Non-Sloping - Propane

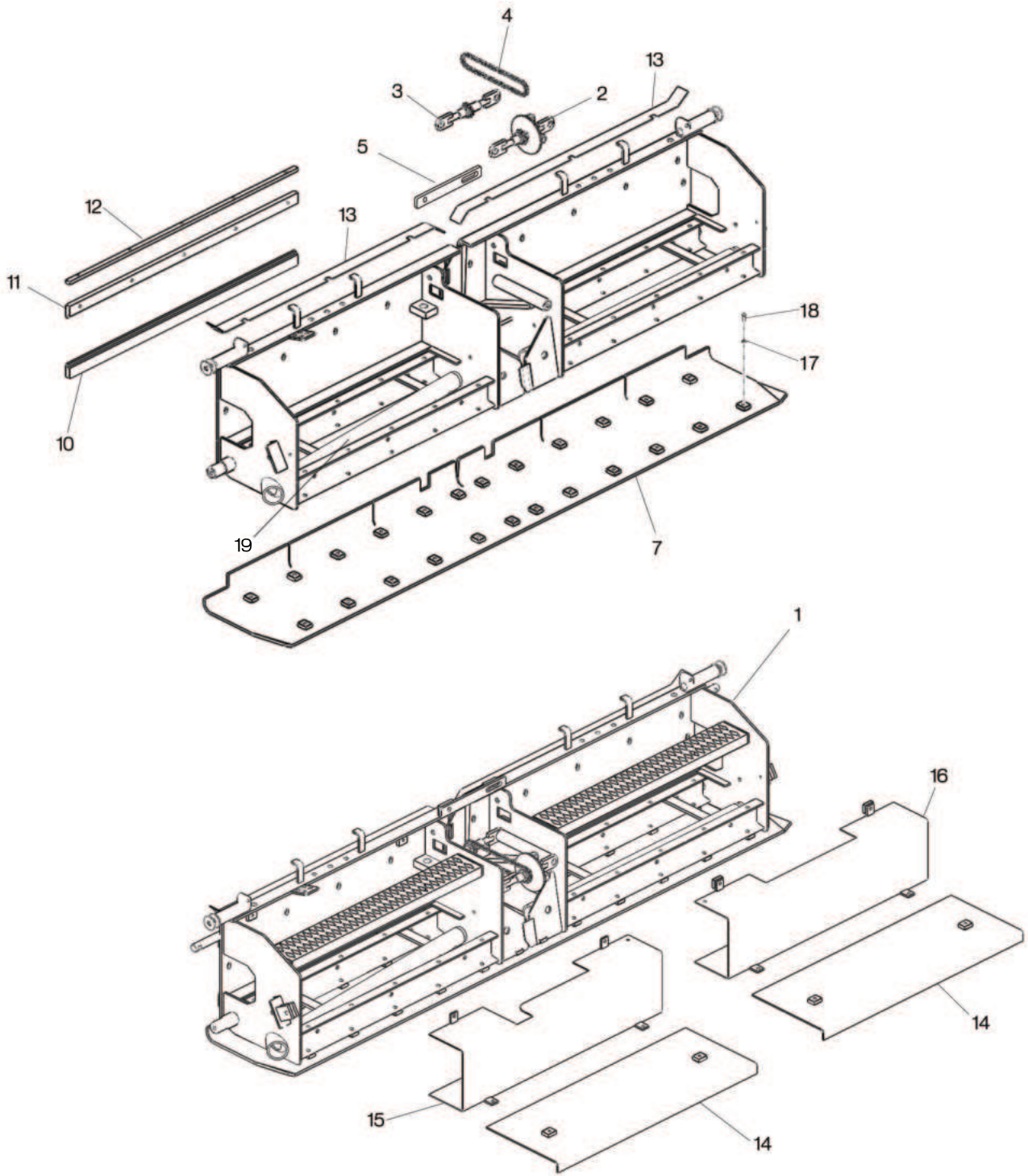

Figure 10-30

Screed Frame Non-Sloping - Propane Parts List

Item No.	Part Number	Qty.	Description	Remarks
1	1000251	1	Group, Screed Base, Propane	Includes item 14, 15, 16
2	870182	1	Crown & Valley Assy, Rear	
3	870172	1	Crown & Valley Assy, Front	
4	870190	1	Chain, Roller, 40 x 52 Pitch	
5	988376	1	Locking Bar, Crown And Valley	
7	981724SRV	1	Wear Plate, 8' Bullnose	
10	855783	1	Bottom Rail, Screed Ext	
11	855784	1	Top Rail, Screed Ext	
12	988556	1	Bar Jack, Screed Slide	
13	855562	1	Bar, .125 x 2.00 x 44.50, Notches	RH or LH
14	851201SRV	2	Cover, Screed Plate Access	
15	851204SRV	1	Cover, Screed LH Ext Cyl	
16	851203SRV	1	Cover, Screed RH Ext Cyl	
17	118-3	24	Washer, Lock, .375	
18	100-205-1A	24	CSHH, .375-24 x 1.00, GR5	
19	851197-1	2	Pipe, Screed Burner, Med	
-	982824SRV	1	Screed, 8500B, LP, 8' to 15'	Not Shown
-	982823SRV	1	Screed, 8500B, Low Deck, 8' to 15', Electric	Not Shown

Extension Single Adjust LH Assembly - Propane

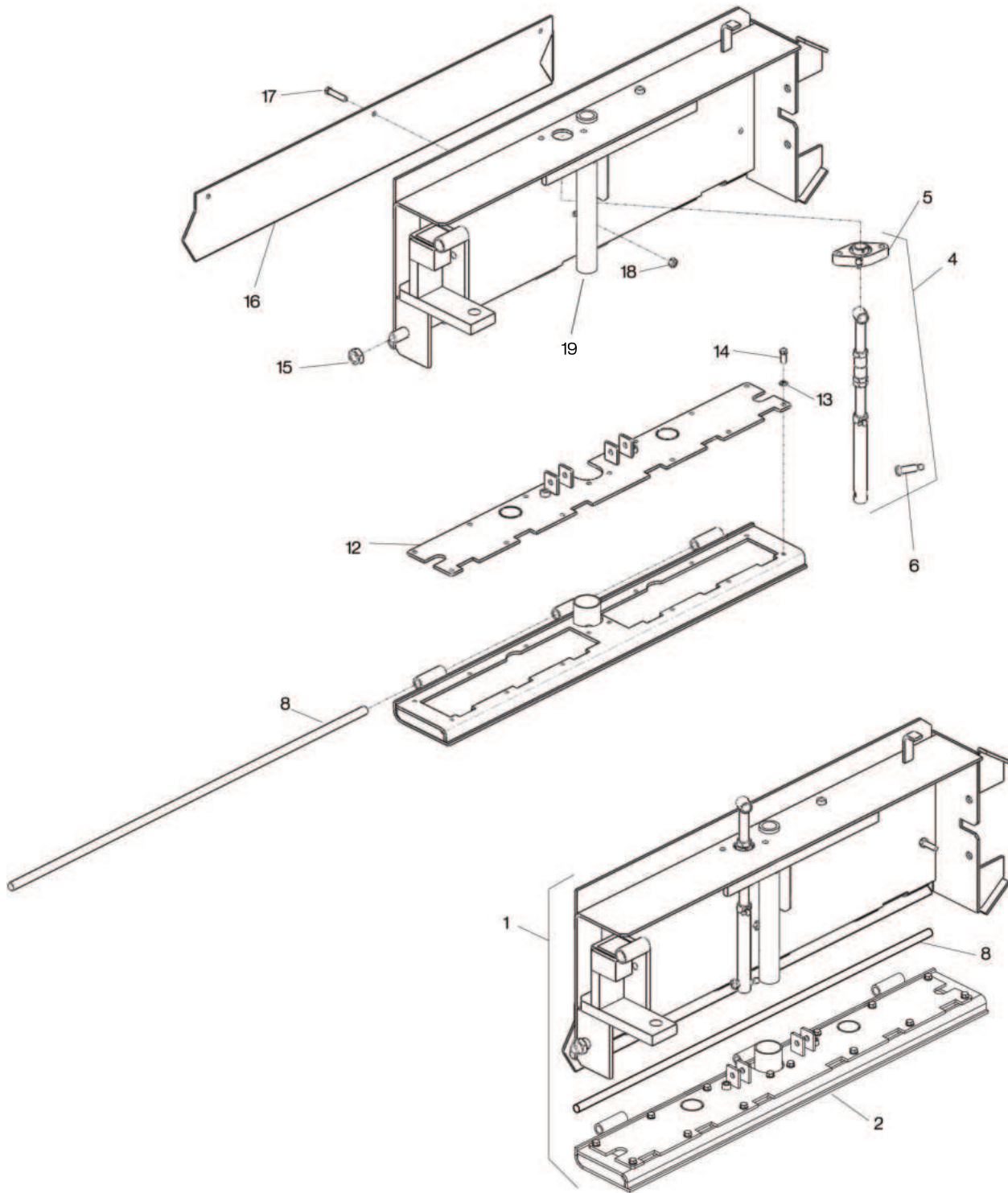

Figure 10-31

Extension Single Adjust LH Assembly - Propane Parts List

Item No.	Part Number	Qty.	Description	Remarks
1	859394SRV	1	Assy, Insert, Propane, LH	
2	851182SRV	1	Assy, Heat Box, Propane, Single Adj	
4	851185SRV	1	Ext Adj Screw Assy	
5	870030	1	Bearing, Screed Flight Screw	
6	870279	1	CSSH, .375-16 Shldr Socket	
8	854447	1	Rnd, .688 x 43.50, CRS	
12	988291	1	Assy, Heat Box Cover, Single Adj	
13	118-3	22	Washer, Lock, .375	
14	81068	22	CSHH, .375-24 x 1.00, GR8	
15	987396	1	Nut, .875-9 UNC-2B Nylon Lock	
16	851180LSRV	1	Guard, LH Screed Ext Hinge	
17	860048	3	CSHH, .437-14 x 1.25, GR5	
18	116-4	3	Nut, .437-14 Hex	
19	851600-1	A/R	Ext. Burner Pipe	

Extension Single Adjust RH Assembly - Propane

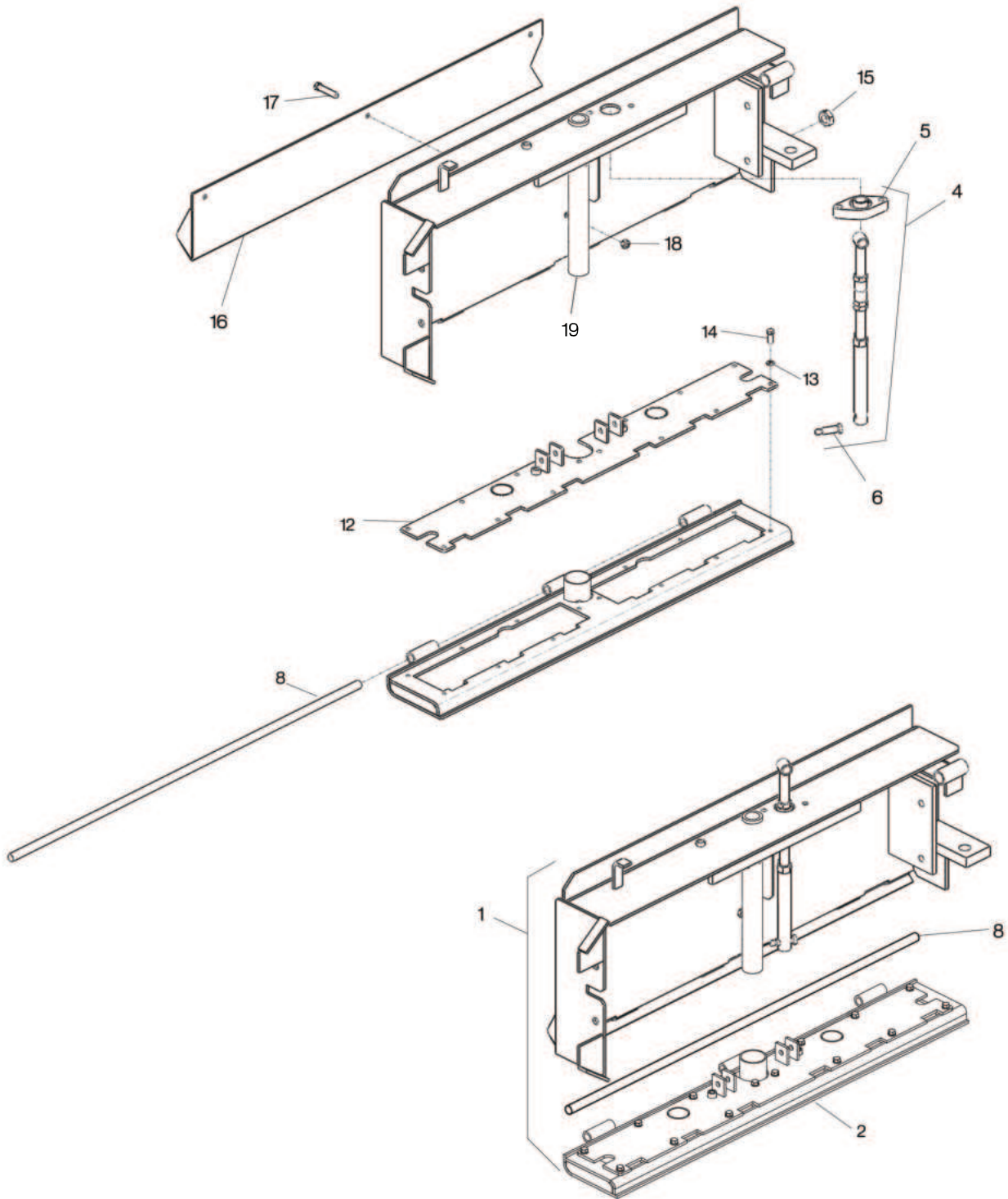

Figure 10-32

Extension Single Adjust RH Assembly - Propane Parts List

Item No.	Part Number	Qty.	Description	Remarks
1	859395SRV	1	Assy, Insert, Propane, RH	
2	851182SRV	1	Assy, Heat Box, Propane, Single Adj	
4	851185SRV	1	Ext Adj Screw Assy	
5	870030	1	Bearing, Screed Flight Screw	
6	870279	1	CSSH, .375-16 Shldr Socket	
8	854447	1	Rnd, .688 x 43.50, CRS	
12	988291	1	Assy, Heat Box Cover, Single Adj	
13	118-3	22	Washer, Lock, .375	
14	81068	22	CSHH, .375-24 x 1.00, GR8	
15	987396	1	Nut, .875-9 UNC-2B Nylon Lock	
16	851180RSRV	1	Guard, RH Screed Ext Hinge	
17	860048	3	CSHH, .437-14 x 1.25, GR5	
18	116-4	3	Nut, .437-14 Hex	
19	851600-1	A/R	Ext. Burner Pipe	

Extension Double Adjust LH Assembly - Propane

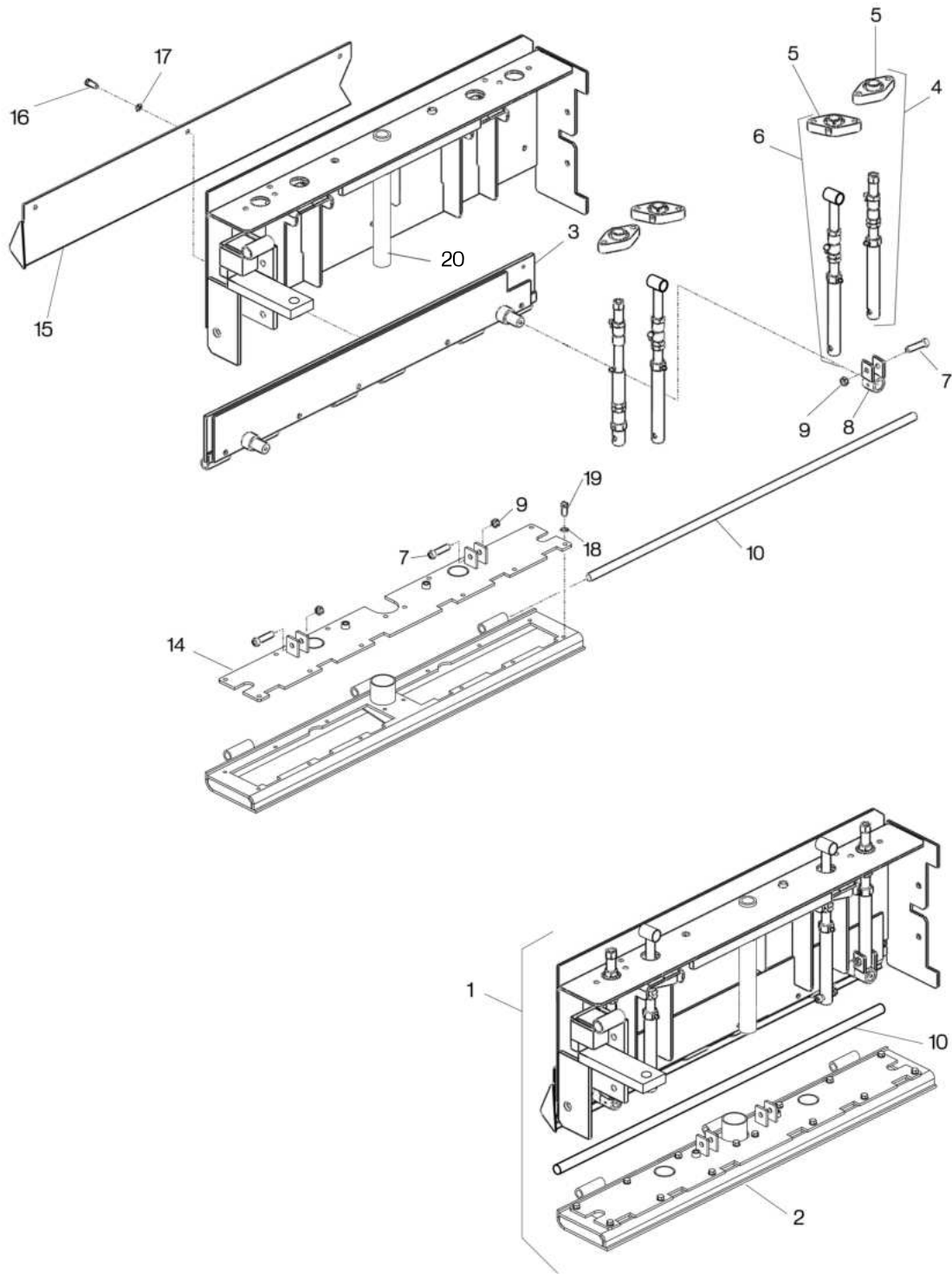

Figure 10-33

Extension Double Adjust LH Assembly - Propane Parts List

Item No.	Part Number	Qty.	Description	Remarks
1	983409-1SRV	1	Assy, Insert, Propane, LH	Without Slope
2	988318SRV	1	Assy, Heat Box, Propane, 4 Adjust	
3	1002735	1	Hinge Assy	
4	985556	1	Assy, Slide Adjust	
5	870030	4	Bearing, Screed Flight Screw	
6	851185SRV	1	Ext Adj Screw Assy	
7	870279	4	CSSH, .375-16 Shldr Socket	
8	1002715	1	Adjuster Mount	
9	143-3	4	Nut, .375-16 Lock	
10	854447	1	Rnd, .688 x 43.50, CRS	
14	988292	1	Assy, Heat Box Cover, 4 Adj	
15	851180LSRV	1	Guard, LH Screed Ext Hinge	
16	80230	3	CSHH, .375-16 x 2.00	
17	119-4	3	Washer, Lock, SAE, .375	
18	118-1	22	Washer, Lock, .250	
19	80185	22	CSHH, .250-20 x 1.00	
20	851600-1	A/R	Ext. Burner Pipe	

Extension Double Adjust RH Assembly - Propane

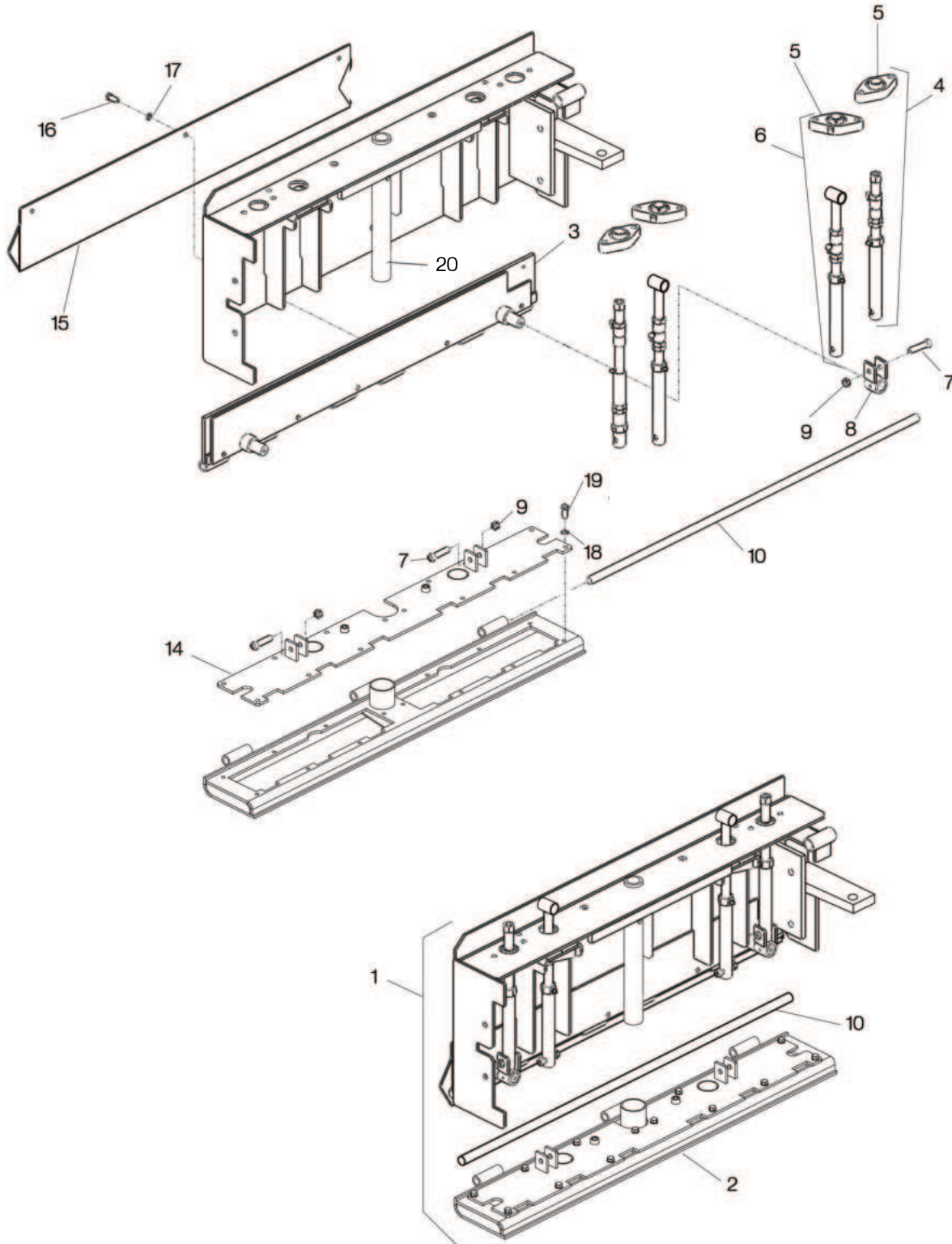

Figure 10-34

Extension Double Adjust RH Assembly - Propane Parts List

Item No.	Part Number	Qty.	Description	Remarks
1	983410-1SRV	1	Assy, Insert, Propane, RH, 4	Without Slope
2	988318SRV	1	Assy, Heat Box, Propane, 4 Adjust	
3	1002736	1	Hinge Assy	
4	985556	1	Assy, Slide Adjust	
5	870030	4	Bearing, Screed Flight Screw	
6	851185SRV	1	Ext Adj Screw Assy	
7	870279	4	CSSH, .375-16 Shldr Socket	
8	1002715	1	Adjuster Mount	
9	143-3	4	Nut, .375-16 Lock	
10	854447	1	Rnd, .688 x 43.50, CRS	
14	988292	1	Assy, Heat Box Cover, 4 Adj	
15	851180RSRV	1	Guard, RH Screed Ext Hinge	
16	80230	3	CSHH, .375-16 x 2.00	
17	119-4	3	Washer, Lock, SAE, .375	
18	118-1	22	Washer, Lock, .250	
19	80185	22	CSHH, .250-20 x 1.00	
20	851600-1	A/R	Ext. Burner Pipe	

Screed Frame Non-Sloping - Electric

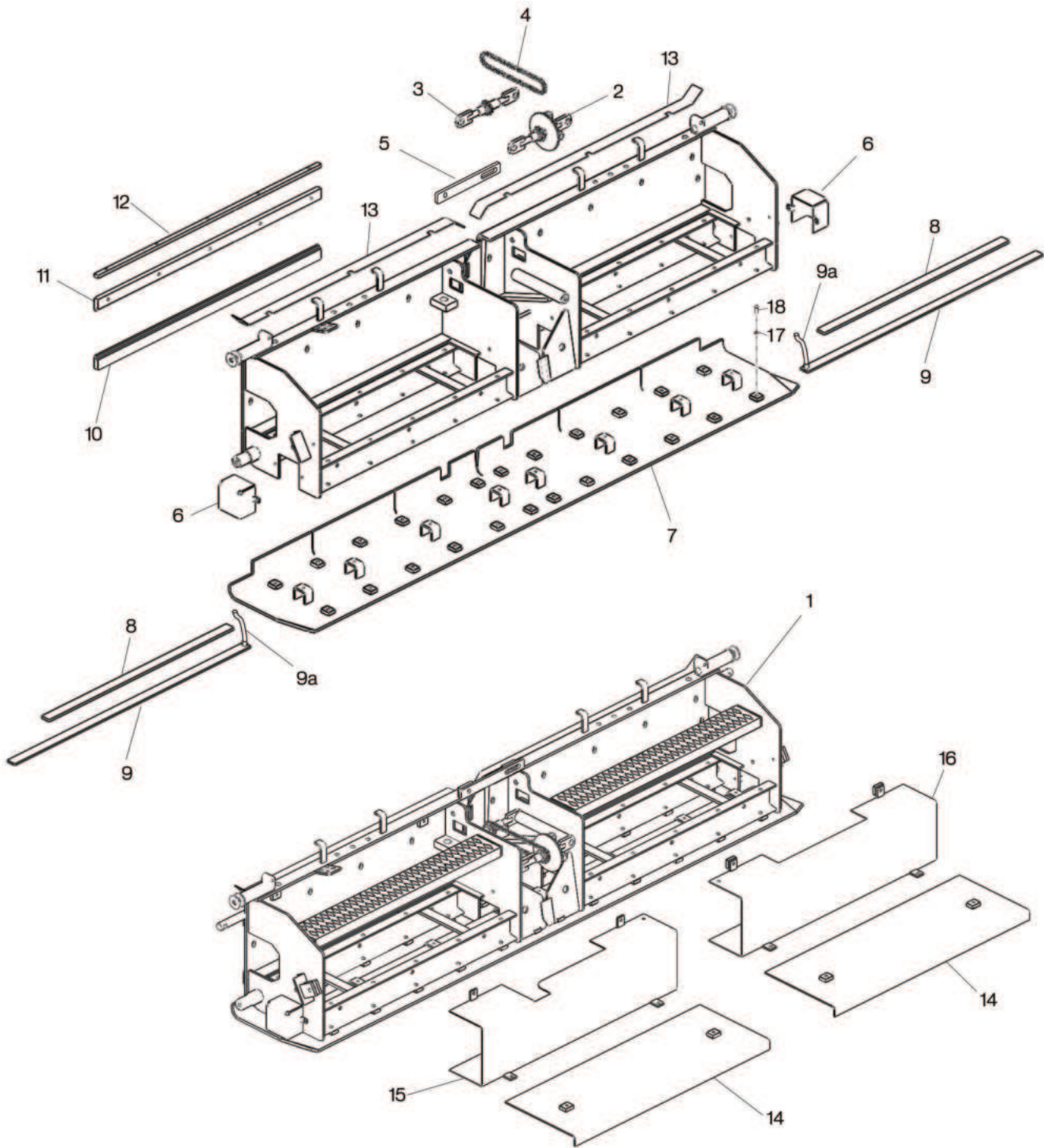

Figure 10-35

Screed Frame Non-Sloping - Electric Parts List

Item No.	Part Number	Qty.	Description	Remarks
1	989377SRV	1	Group, Screed Base, Elec	Includes item 14, 15, 16
2	870182	1	Crown & Valley Assy, Rear	
3	870172	1	Crown & Valley Assy, Front	
4	870190	1	Chain, Roller, 40 x 52 Pitch	
5	988376	1	Locking Bar, Crown And Valley	
6	985124	2	Cover, Elements, Screed Base	
7	987216SRV	1	Wear Plate Assy, Electric	
8	985121	2	Bar, .375 x 1.50 x 42	
9	987886SRV	2	Element, Heater, Screed, 46"	
9a	985699-03	2	Wiring, Element, Heater Pigtail	
10	855783	1	Bottom Rail, Screed Ext	
11	855784	1	Top Rail, Screed Ext	
12	988556	1	Bar Jack, Screed Slide	
13	855562	1	Bar, .125 x 2.00 x 44.50, Notches	RH or LH
14	851201SRV	2	Cover, Screed Plate Access	
15	851204SRV	1	Cover, Screed LH Ext Cyl	
16	851203SRV	1	Cover, Screed RH Ext Cyl	
17	118-3	24	Washer, Lock, .375	
18	100-205-1A	24	CSHH, .375-24 x 1.00, GR5	

Vibrator Assembly

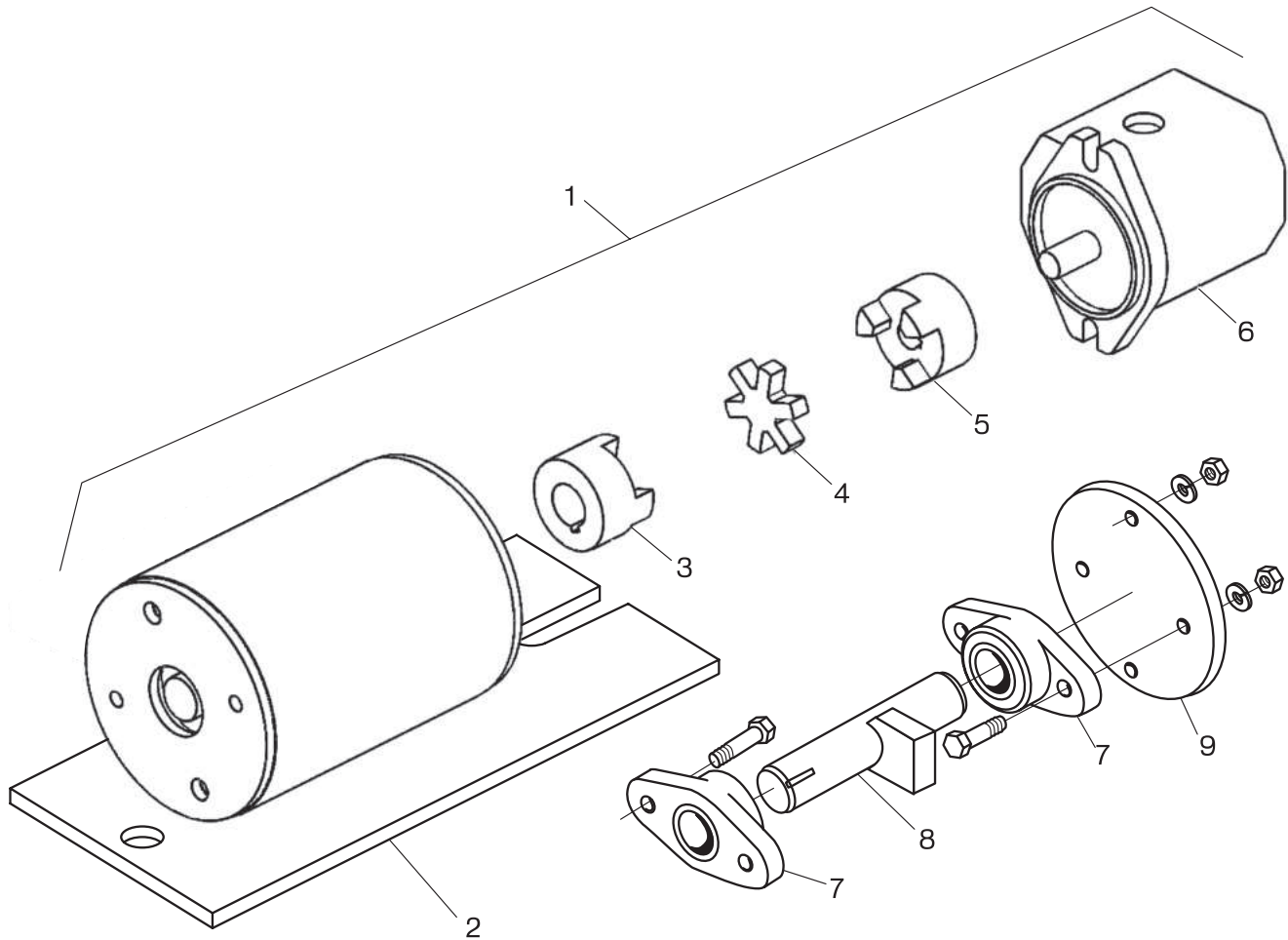

Figure 10-36

Vibrator Assembly Parts List

Item No.	Part Number	Qty.	Description	Remarks
1	855253	1	Assy, Vibrator	
2	855535	1	Vibrator Housing	
3	880030	1	Coupling Half, 1.00, Vibrator Shaft	
4	280040	1	Insert, 3-Jaw Coupling	
5	280030	1	Coupling Half, Tack Pump Motor	
6	983405	1	Hyd. Motor, Screed Vibrator	
7	250150	2	Bearing, Conveyor Pulley/Vibrator Shaft	
8	880062	1	Shaft, Vibrator Eccentric	
9	880071	1	Plate, Vibrator Housing	

Walk Board Assembly

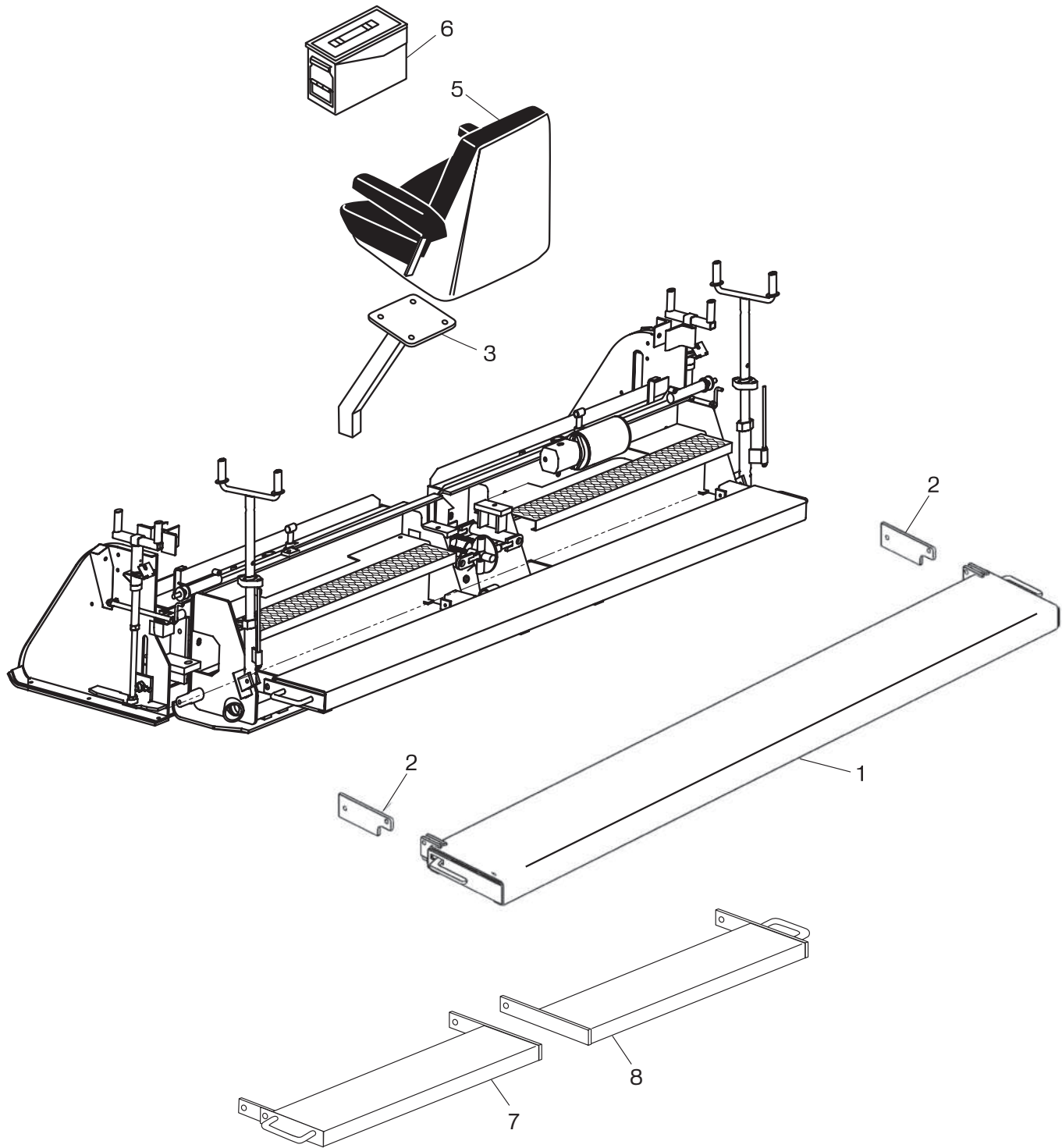

Figure 10-37

Walk Board Assembly Parts List

Item No.	Part Number	Qty.	Description	Remarks
1	987056	1	Assy, Walk Board	Includes item 2
2	985163	2	Walk Board Brkt	
3	360010	1	Seat Assy W / Armrest, White	
5	920024	1	Support, Seat H/D	
6	851169	1	Tool Box	
7	851176LSRV	1	Walkboard Assy, 8500 Lower, LH	
8	851176RSRV	1	Walkboard Assy, 8500 Lower, RH	
—	920235	A/R	Umbrella	

Slide Plate Assembly

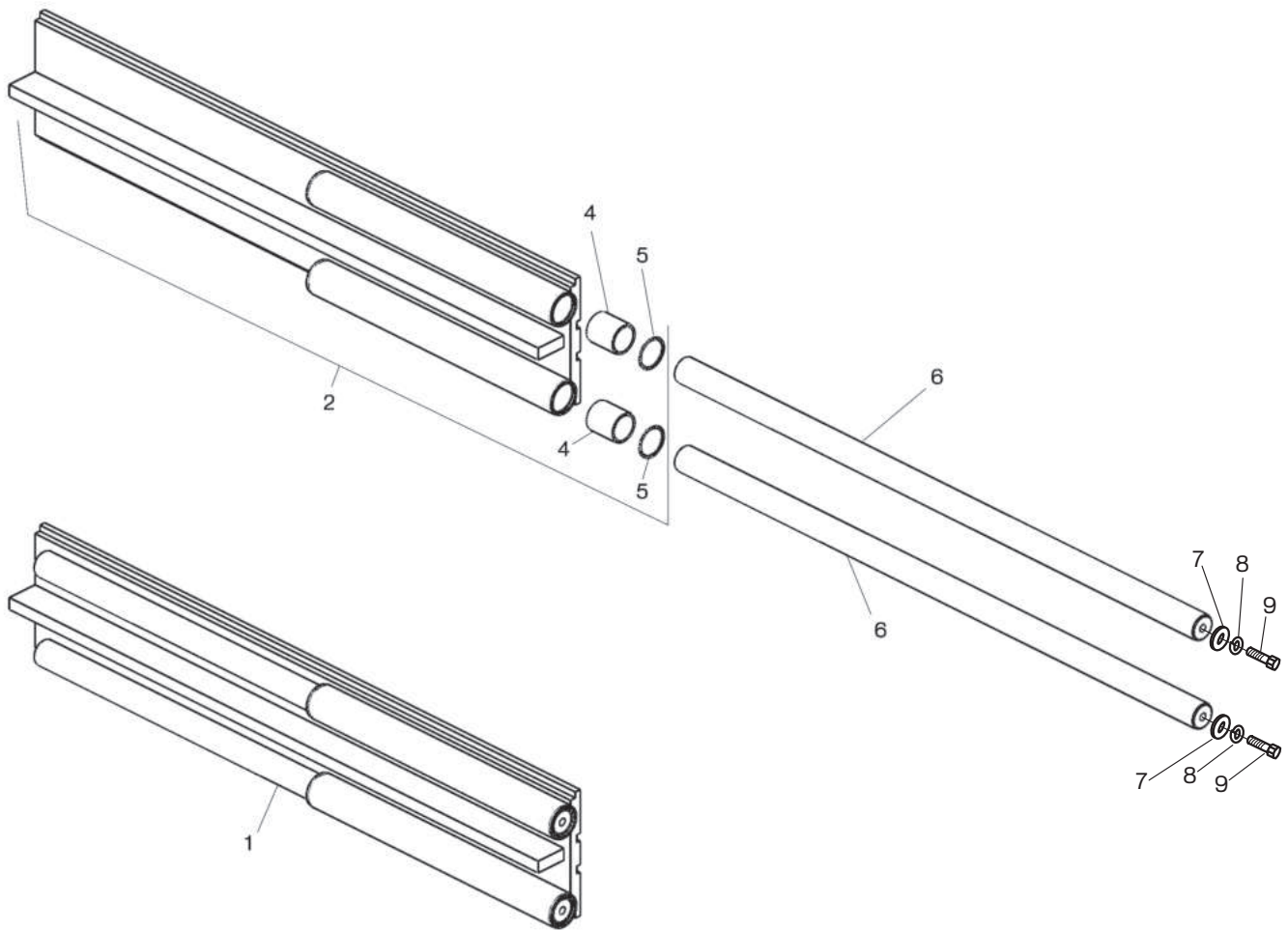

Figure 10-38

Slide Plate Assembly Parts List

Item No.	Part Number	Qty.	Description	Remarks
1	1002186	1	Slide Plate Assembly with Chrome Rods	
2	1002181	1	Slide Plate Assembly	
4	988588	4	Bushing, Fiber	
5	851256	4	Snap Ring	
6	988601	2	Chrome Rod	
7	119-5	4	Washer, Flat, .500	
8	118-5	4	Washer, Lock, .500	
9	100-408-1	4	CSSH, .500-20X1.50	

Extension Single Adjust LH Assembly - Electric

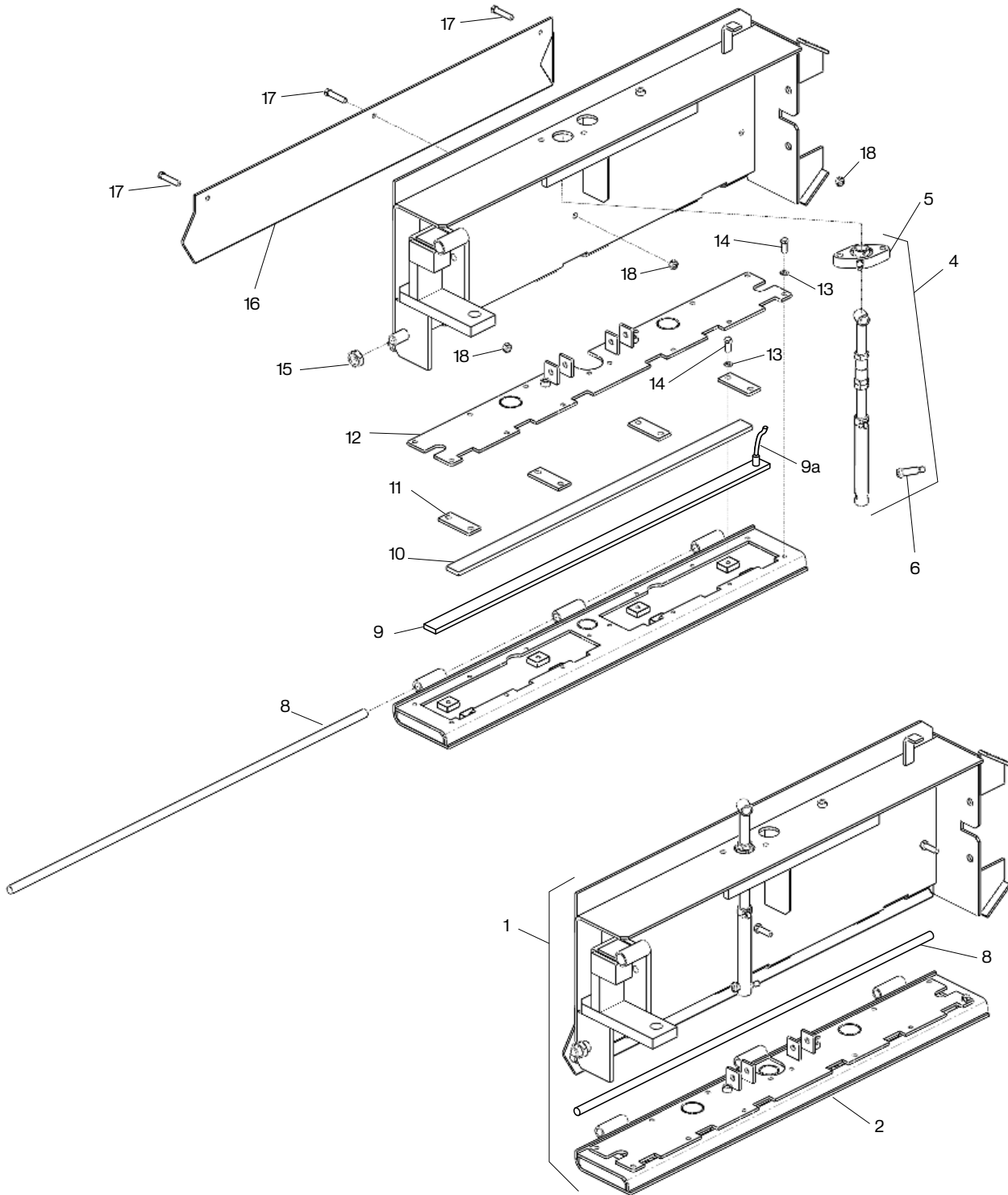

Figure 10-39

Extension Single Adjust LH Assembly - Electric Parts List

Item No.	Part Number	Qty.	Description	Remarks
1	985561SRV	1	Assy, Insert, Electric, 8500, LH	
2	987872SRV	1	Assy, Heat Box, Elec, Single Adj	
4	851185SRV	1	Ext Adj Screw Assy	
5	870030	1	Bearing, Screed Flight Screw	
6	870279	1	CSSH, .375-16 Shldr Socket	
8	854447	1	Rnd, .688x43.50, CRS	
9	987890SRV	1	Element, Heater, Screed, 40"	
9a	985699-03	1	Wiring, Element, Heater Pigtail	
10	985120	1	Bar, .25x1.5x36	
11	985123	4	Clamp, Element, Screed Ext	
12	988291	1	Assy, Heat Box Cover, Single Adj	
13	118-3	22	Washer, Lock, .375	
14	81068	22	CSHH, .375-24X1.00, GR8	
15	987396	1	Nut, .875-9 UNC-2B Nylon Lock	
16	851180LSRV	1	Guard, LH Screed Ext Hinge	
17	860048	3	CSHH, .437-14X1.25, GR5	
18	116-4	3	Nut, .437-14 Hex	

Extension Single Adjust RH Assembly - Electric

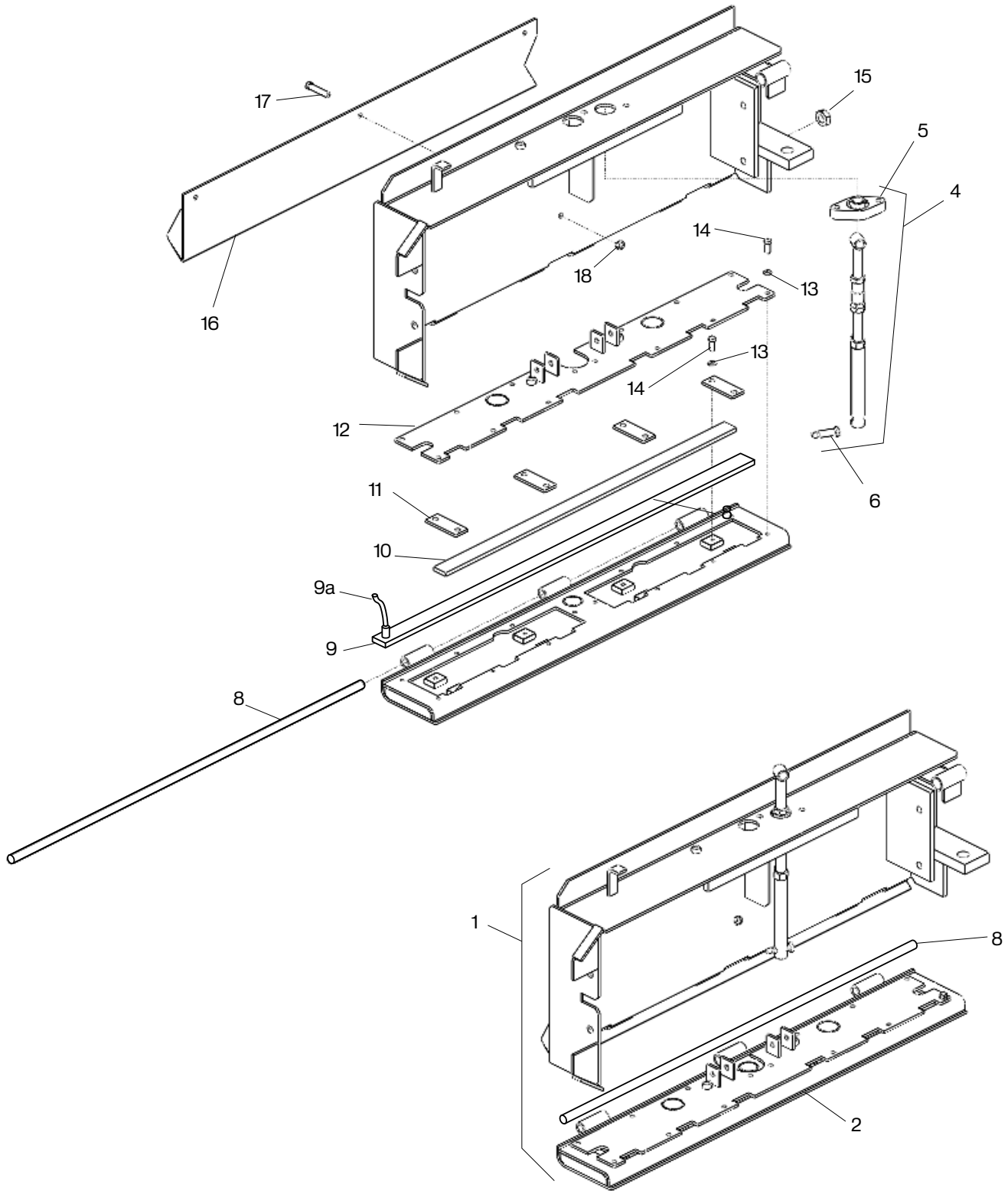

Figure 10-40

Extension Single Adjust RH Assembly - Electric Parts List

Item No.	Part Number	Qty.	Description	Remarks
1	985562SRV	1	Assy, Insert, Electric, 8500, RH	
2	987872SRV	1	Assy, Heat Box, Elec, Single Adj	
4	851185SRV	1	Ext Adj Screw Assy	
5	870030	1	Bearing, Screed Flight Screw	
6	870279	1	CSSH, .375-16 Shldr Socket	
8	854447	1	Rnd, .688x43.50, CRS	
9	987890SRV	1	Element, Heater, Screed, 40"	
9a	985699-03	1	Wiring, Element, Heater Pigtail	
10	985120	1	Bar, .25x1.5x36	
11	985123	4	Clamp, Element, Screed Ext	
12	988291	1	Assy, Heat Box Cover, Single Adj	
13	118-3	22	Washer, Lock, .375	
14	81068	22	CSHH, .375-24X1.00, GR8	
15	987396	1	Nut, .875-9 UNC-2B Nylon Lock	
16	851180RSRV	1	Guard, RH Screed Ext Hinge	
17	860048	3	CSHH, .437-14X1.25, GR5	
18	116-4	3	Nut, .437-14 Hex	

Extension Double Adjust LH Assembly - Electric

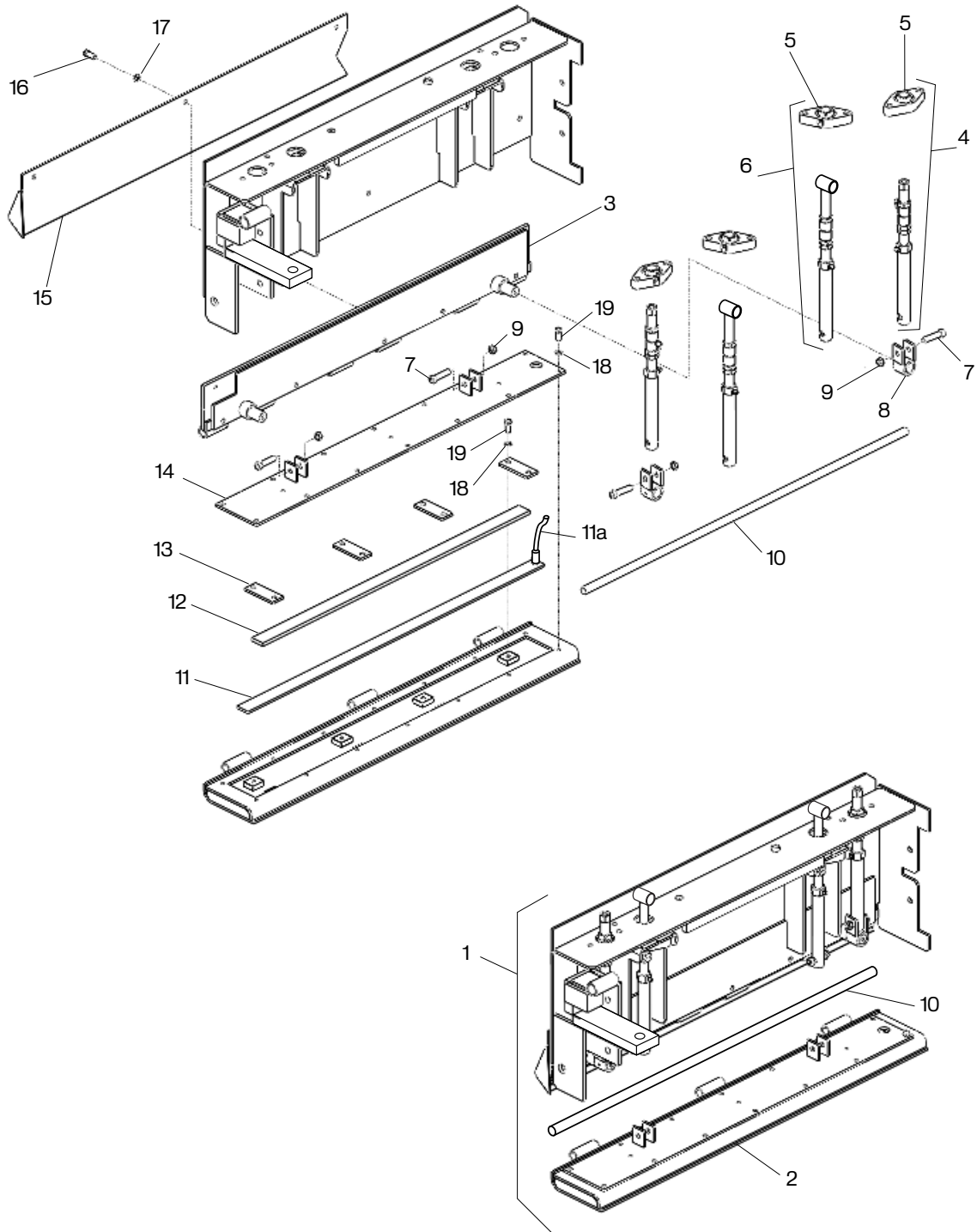

Figure 10-41

Extension Double Adjust LH Assembly - Electric Parts List

Item No.	Part Number	Qty.	Description	Remarks
1	984305-1	1	Assy, Insert, Elec, LH	Without Slope
2	988319SRV	1	Assy, Heat Box, Elec, 4 Adjust	
3	1002735	1	Hinge Assembly	
4	985556	1	Assy, Slide Adjust	
5	870030	4	Bearing, Screed Flight Screw	
6	851185SRV	1	Ext Adj Screw Assy	
7	870279	4	CSSH, .375-16 Shldr Socket	
8	1002715	1	Adjuster Mount	
9	143-3	4	Nut, .375-16 Lock	
10	854447	1	Rnd, .688x43.50, CRS	
11	987890SRV	1	Element, Heater, Screed, 40"	
11a	985699-03	1	Wiring, Element, Heater Pigtail	
12	985120	1	Bar, .25x1.5x36	
13	985123	4	Clamp, Element, Screed Ext	
14	988292	1	Assy, Heat Box Cover, 4 Adj	
15	851180LSRV	1	Guard, LH Screed Ext Hinge	
16	80230	3	CSHH, .375-16X2.00	
17	119-4	3	Washer, Lock, .375	
18	118-1	22	Washer, Lock, .250	
19	80185	22	CSHH, .250-20X1.0	

Extension Double Adjust RH Assembly - Electric

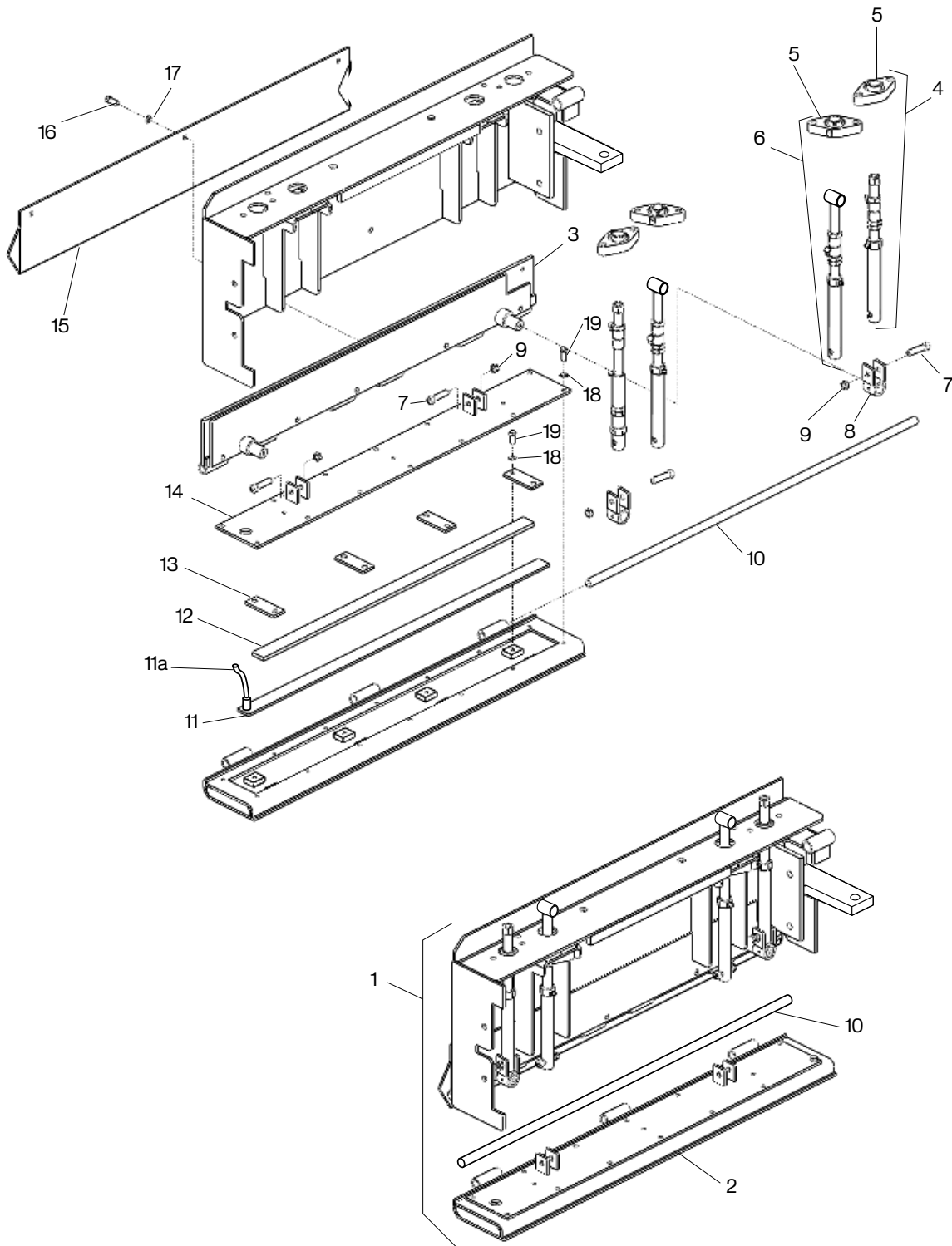

Figure 10-42

Extension Double Adjust RH Assembly - Electric Parts List

Item No.	Part Number	Qty.	Description	Remarks
1	984306-1	1	Assy, Insert, Elec, RH, 4	Without Slope
2	988319SRV	1	Assy, Heat Box, Elec, 4 Adjust	
3	1002736	1	Hinge Assembly	
4	985556	1	Assy, Slide Adjust	
5	870030	4	Bearing, Screed Flight Screw	
6	851185SRV	1	Ext Adj Screw Assy	
7	870279	4	CSSH, .375-16 Shldr Socket	
8	1002715	1	Adjuster Mount	
9	143-3	4	Nut, .375-16 Lock	
10	854447	1	Rnd, .688x43.50, CRS	
11	987890SRV	1	Element, Heater, Screed, 40"	
11a	985699-03	1	Wiring, Element, Heater Pigtail	
12	985120	1	Bar, .25x1.5x36	
13	985123	4	Clamp, Element, Screed Ext	
14	988292	1	Assy, Heat Box Cover, 4 Adj	
15	851180RSRV	1	Guard, RH Screed Ext Hinge	
16	80230	3	CSHH, .375-16X2.00	
17	119-4	3	Washer, Lock, .375	
18	118-1	22	Washer, Lock, .250	
19	80185	22	CSHH, .250-20X1.0	

Endgate LH Assembly

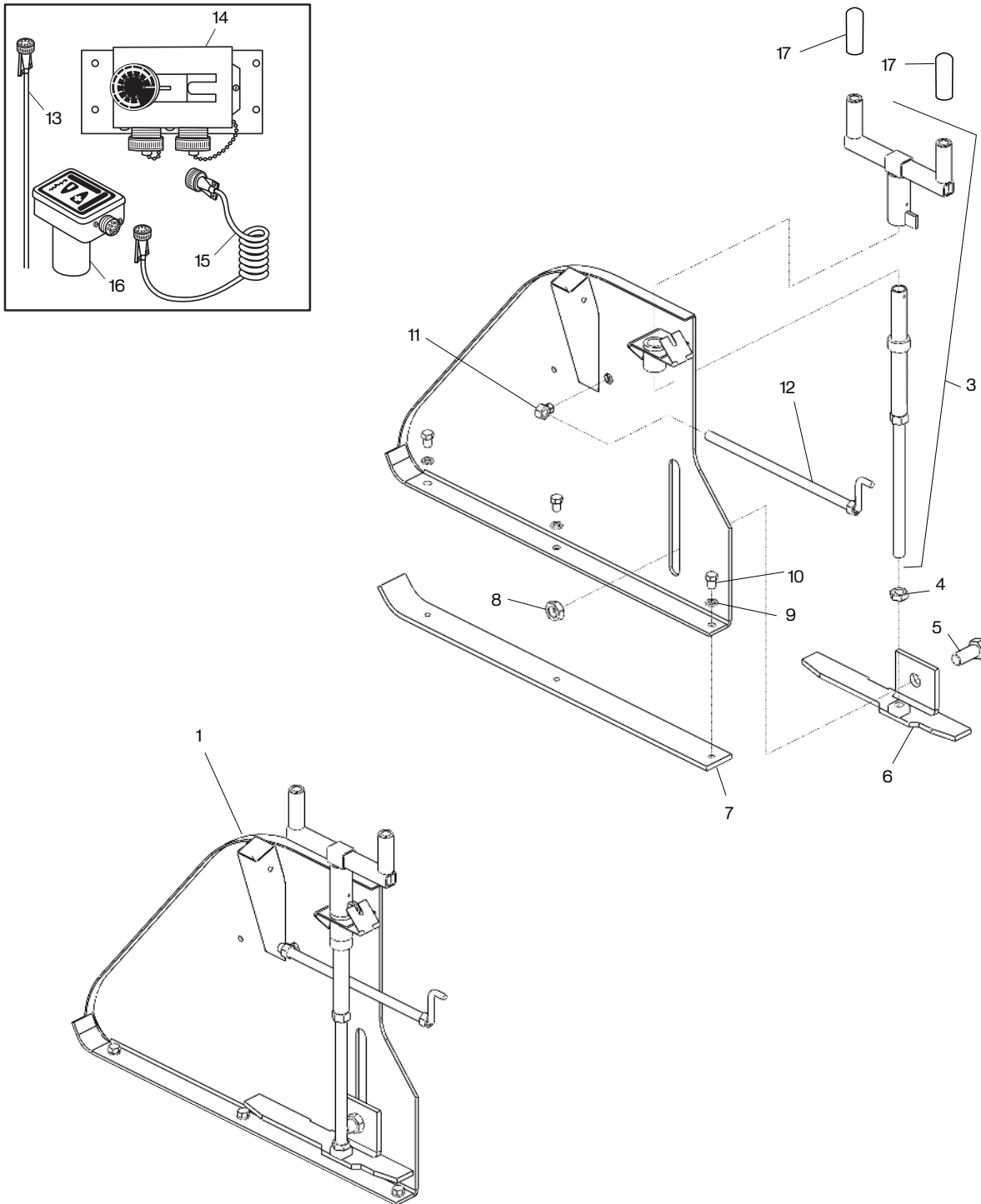

Figure 10-43

Endgate LH Assembly Parts List

Item No.	Part Number	Qty.	Description	Remarks
1	851682	1	Jointer Assy, 8500, LH	
3	890092SRV	1	Depth Screw Assy, Screed	
4	116-8-1	1	Nut, .750-10 UNC Hex Jam	
5	102-809-1A	1	CSHH, .875-9X2.00, GR5	Reference Only
6	890132LSRV	1	Bracket, Depth Screw Control LH	
7	982963	1	Bar, End Gate Skid 8515	
8	116-9	1	Nut, .875-9 Hex	
9	80164	3	Washer, Lock, .500	
10	80840	3	CSHH, .500-13X0.75	
11	890070	1	Assy, Adjusting Swivel Nut	
12	890081SRV	1	Tilt Screw, Jointer Assy	
13	983271	1	Cable, Sonic Sensor Straight	
14	982795	1	Remote Pod, Ultra Sonic	
15	982796	1	Power Cable, Ultra Sonic	
16	982794	1	Sensor, Ultra Sonic	
17	870276	2	Hand Grip, Flight/Depth Screw	

Endgate RH Assembly

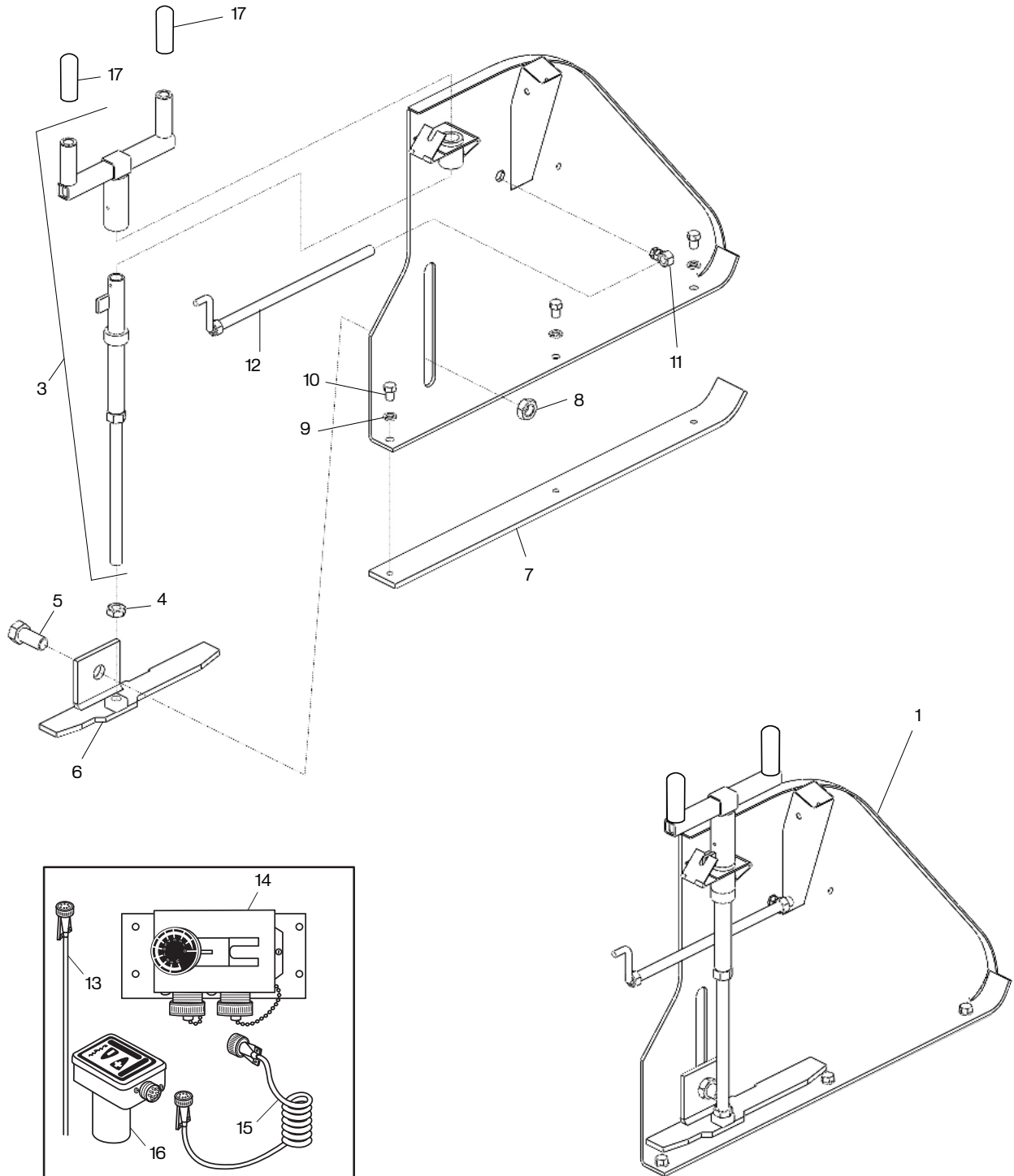

Figure 10-44

Endgate RH Assembly Parts List

Item No.	Part Number	Qty.	Description	Remarks
1	851683	1	Jointer Assy, 8500, RH	
3	890092SRV	1	Depth Screw Assy, Screed	
4	116-8-1	1	Nut, .750-10 UNC Hex Jam	
5	102-809-1A	1	CSHH, .875-9X2.00, GR5	Reference Only
6	890132RSRV	1	Bracket, Depth Screw Control RH	
7	982963SRV	1	Wear Plate, End Gate, 8515	
8	987396	1	Nut, .875-9 UNC-2B Nylon Lock	
9	118-5	3	Washer, Lock, .500	
10	80840	3	CSHH, .500-13X0.75	
11	890070	1	Assy, Adjusting Swivel Nut	
12	890081SRV	1	Tilt Screw, Jointer Assy	
13	982796	1	Cable, Power, Ultrasonic	
14	982795	1	Remote Pod, Ultra Sonic	
15	983050	1	Coil Cord, 6s/6s 1.5 to 7.5 ft	
16	982794	1	Sensor, Ultra Sonic	
17	870276	2	Hand Grip, Flight/Depth Screw	

Screed Pull Arms LH Assembly

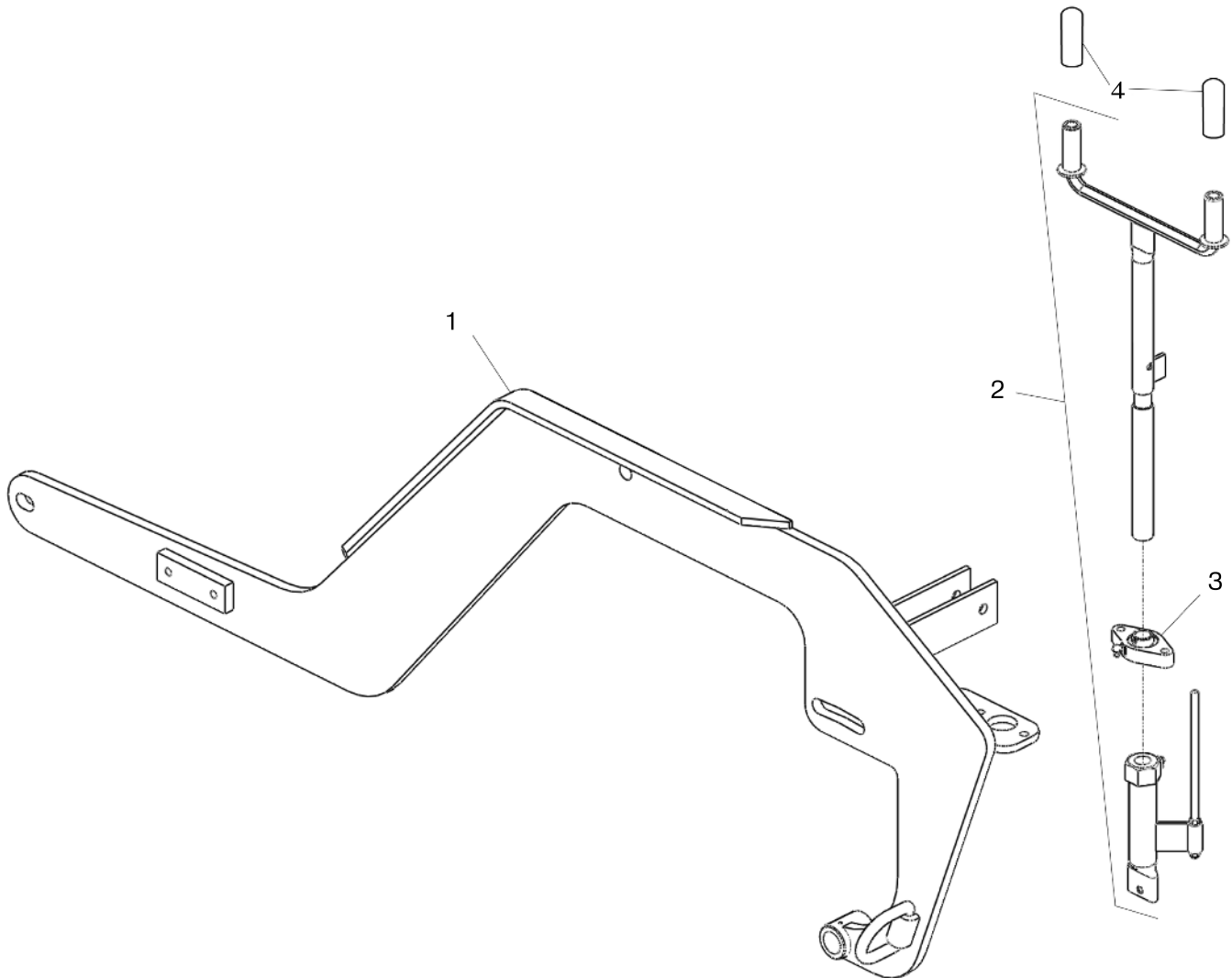

Figure 10-45

Screed Pull Arms LH Assembly Parts List

Item No.	Part Number	Qty.	Description	Remarks
1	982743LSRV	1	Assy, Screed Arm, LH	
2	1002728SRV	1	Flight Screw Assy	PN 851370 is same w/o height rod
3	870030	1	Bearing, Screed Flight Screw	
4	870276	2	Hand Grip, Flight/Depth Screw	

Screed Pull Arms RH Assembly

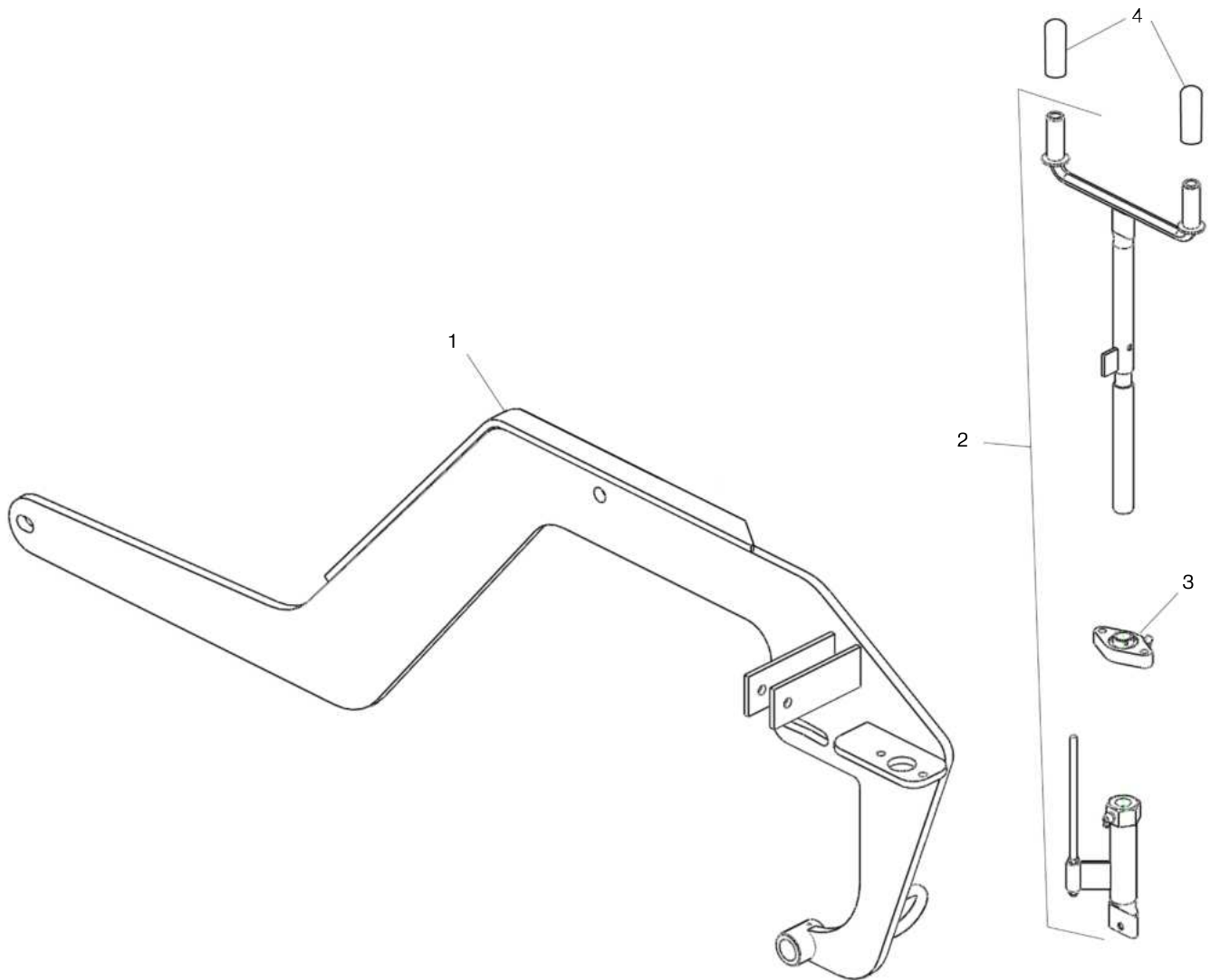

Figure 10-46

Screed Pull Arms RH Assembly Parts List

Item No.	Part Number	Qty.	Description	Remarks
1	982743RSRV	1	Assy, Screed Arm, RH	
2	1002728SRV	1	Flight Screw Assy	PN 851370 is same w/o height rod
3	870030	1	Bearing, Screed Flight Screw	
4	870276	2	Hand Grip, Flight/Depth Screw	

Citrus Tank & Heat Control Box

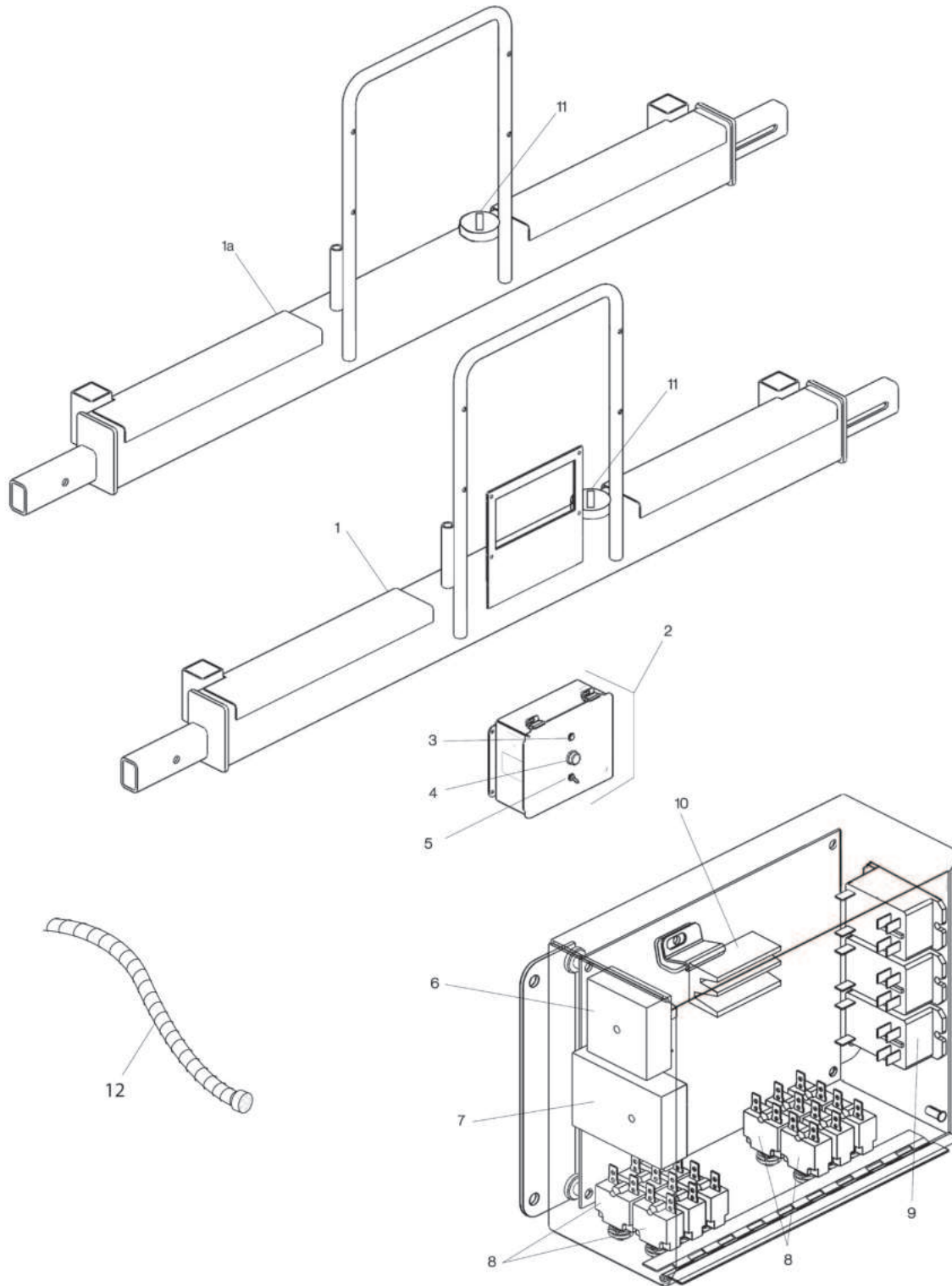

Figure 10-47

Citrus Tank & Heat Control Box Parts List

Item No.	Part Number	Qty.	Description	Remarks
1	987099SRV	1	Assy, Screed, Citrus, Tank, Elec	Includes Item No. 11
1a	985777SRV	1	Assy, Screed, Citrus, Tank, Propane	Includes Item No. 11
2	985138	1	Assy, Electric Heat Control	
3	31983	1	Light, Red, Dash, .500 Hole	
4	982249	1	Switch, Push Button	
5	851391	1	Switch, Toggle, SPST, 2-POS	
6	985142	1	Timer, Elec	
7	988231	1	Relay, Time Delay, Off, 10 Amp	
8	985140	12	Breaker, 15 Amp	
9	985141	3	Relay, 12VDC, DPST ,25 AMP, N/O	
10	985138-04	1	Block, Terminal	
11	140030FL	1	Cap, Fuel Tank, Lockable	
12	985138-03	1	Power Cord, Bulkhead to Control Box	

Screed Miscellaneous Components

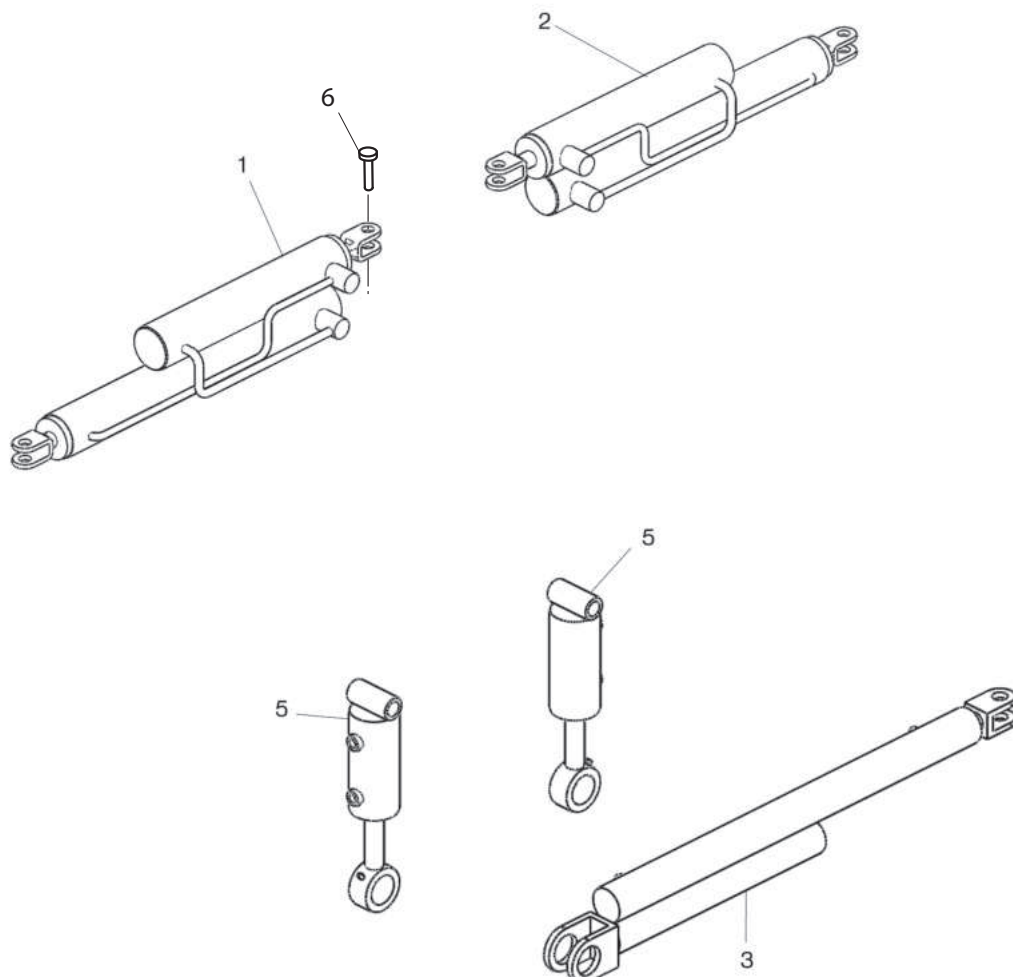

Figure 10-48

Screed Miscellaneous Components Parts List

Item No.	Part Number	Qty.	Description	Remarks
1	851191	1	Cyl, Hyd, 2.00X12.00/30.00X1.25	LH
–	851191-01	1	Seal Kit, Cyl, Hyd, 2.00X12.00/30.00X1.25	Not Shown
2	851192	1	Cyl, Hyd, 2.00X12.00/30.00X1.25	RH
–	851191-01	1	Seal Kit, Cyl, Hyd, 2.00X12.00/30.00X1.25	Not Shown
3	210060	2	Pin, Cylinder	

Generator

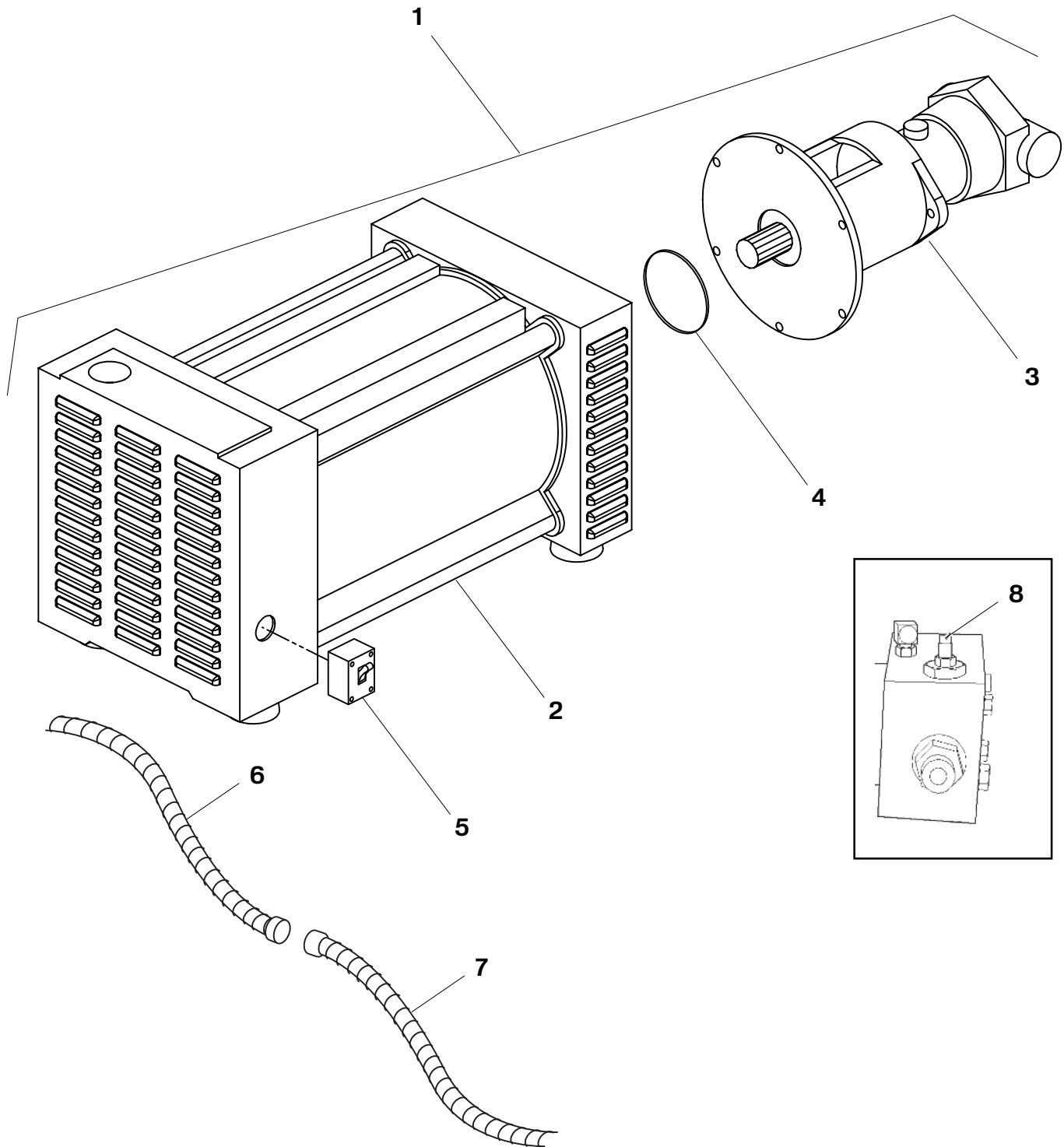

Figure 10-49

Generator Parts List

Item No.	Part Number	Qty.	Description	Remarks
1	987893	1	Generator, Hyd., Assy	Image may not be visually accurate
2	988176	1	Generator, Only	
3	986994	1	Motor, Hyd, Generator	
4	Reference	1	Seal	
5	985880	1	Breaker, Main	
6	985138-03	1	Power Cord, Bulkhead to Control Box	
7	985826	1	Harness, Electric Heat, Gen. to Bulkhead	
8	986992	1	Manifold, Generator, w/Flow Control	
–	986658	1	Capacitor, Generator, 40 uF	Not Shown
–	1002148	1	Capacitor, Generator, 30 uF	Not Shown
–	1002147	1	Capacitor, Generator, 25 uF	Not Shown
–	1002146	1	Capacitor, Generator, 20 uF	Not Shown
–	987894SRV	1	Coupling Assy, Motor To Generator, 28 mm	Not Shown
–	1002454	1	Coupling Half, 3 Jaw, 24 mm	Not Shown

ALPHABETICAL PARTS INDEX

Description	Part Number	Figure Number	Item Number
#10-32 x .750 serrated flange bolt	Reference	10-8	—
.250-20 nylock nut	80350	10-8	—
.250-20 serrated nut	Reference	10-8	—
.250-20 x .500 serrated flange bolt	Reference	10-8	—
.250-20 x .625 serrated flange bolt	Reference	10-8	—
.250-20 x 1.25 hex head bolt	80187	10-8	—
.250-20 x 1.50 hex head bolt	80194	10-8	—
.313-18 x .750 serrated flange bolt	Reference	10-8	—
.375 lock washer	80162	10-8	—
.375 SAE flat washer	80996	10-8	—
.375 x 2.00 fender washer	512156	10-8	—
.375-16 serrated flange nut	Reference	10-8	—
.375-16 x .750 serrated flange bolt	Reference	10-8	—
.375-16 x 1.00 bolt	80221	10-8	—
.375-16 x 1.00 serrated flange bolt	104-205-1A	10-8	—
.375-16 x 1.25 serrated flange bolt	Reference	10-8	—
.375-16 x 2.00 serrated flange bolt	Reference	10-8	—
.375-16 x 2.25 serrated flange bolt	Reference	10-8	—
.375-16 nut	80038	10-8	—
.375-24 hex nut	80056	10-8	—
Actuator, Emulsion Throttle	987985	10-8	32
Actuator, Emulsion Throttle	987985	10-9	37
Adapter, Hose to Pipe (90 deg)	230069	10-13	12
Adapter, Hyd. Hose	2404-10-8	10-1	32
Adapter, P.O.L.	230030	10-13	2
Adapter, Rubber, Insert, 3.00 x 2.25	1001140	10-9	45
Adapter, Throttle Actuator Rod	980317	10-8	33
Adapter, Throttle Actuator Rod	980317	10-9	38
Adapter, Throttle Actuator, Base	980318	10-9	39
Adapter, Throttle Actuator,Base	980318	10-8	34
Adjuster Mount	1002715	10-33	8
Adjuster Mount	1002715	10-34	8
Adjuster Mount	1002715	10-41	8
Adjuster Mount	1002715	10-42	8
Air Breather 90 x 3" - 3.5"	986537-29	10-8	24
Air Cleaner Assy	1003139-03	10-8	13
Air Cleaner Assy	38385	10-9	30
Alternator, CAT C3.4T	988671-10	10-9	—

Description	Part Number	Figure Number	Item Number
Alternator, Kub, Tier3, V3600TB	1001166-04	10-8	—
Alum. Cable Sleeve .0625	981981	10-15	8
AM Module and Cable Assy, w/Base Plate	985866	10-15	18
AM Module Only	985866-01	10-15	—
AM Module Only	985866-01	10-16	10
Angle, 2.00 x 2.00 x .250	980642	10-22	23
Angle, 2.00 x 2.00 x .250	980642	10-23	23
Angle, 2.00 x 2.00 x .250	980642	10-24	18
Angle, 2.00 x 2.00 x .250	980642	10-25	18
Arm Extension, LH	930025SRV	10-17	3
Arm Extension, RH	930020SRV	10-17	2
Arm, Assy, Truck Hitch Wheel Pivot	930030SRV	10-17	4
Arm, Auto. Conveyor Switch	900060	10-3	37
Arm, Left Drive	320245	10-10	16
Arm, Right Drive	900025	10-10	17
Arm, Skid Support (Front)	851248SRV	10-15	12
Arm, Skid Support (Rear)	851247SRV	10-15	11
Assy CB Bracket	983414-09	10-16	20
Assy Temp. Bail w/Sleeves	983414-10	10-16	1
Assy, 20 Ft. Kit	851584SRV	10-15	—
Assy, 30 Ft. to 40 Ft. Kit	851585SRV	10-15	—
Assy, Adjusting Swivel Nut	890070	10-43	11
Assy, Adjusting Swivel Nut	890070	10-44	11
Assy, Axle, Guide Wheel	930045SRV	10-17	8
Assy, Beacon Light Post	989469SRV	10-22	22
Assy, Beacon Light Post	989469SRV	10-23	22
Assy, Beacon Light Post	989469SRV	10-24	17
Assy, Beacon Light Post	989469SRV	10-25	17
Assy, Cable Mount	1003653	10-10	3
Assy, Cord Remote (TOPCON)	984596	10-15	—
Assy, Cord Remote (TOPCON)	984596	10-16	8
Assy, Electric Heat Control	985138	10-47	2
Assy, Engine Cover, CAT	1003309	10-24	9
Assy, Engine Cover, CAT	1003309	10-25	8
Assy, Heat Box Cover, 4 Adj	988292	10-33	14
Assy, Heat Box Cover, 4 Adj	988292	10-34	14
Assy, Heat Box Cover, 4 Adj	988292	10-41	14
Assy, Heat Box Cover, 4 Adj	988292	10-42	14
Assy, Heat Box Cover, Single Adj	988291	10-31	12
Assy, Heat Box Cover, Single Adj	988291	10-32	12

Illustrated Parts List (IPL)



Description	Part Number	Figure Number	Item Number
Assy, Heat Box Cover, Single Adj	988291	10-39	12
Assy, Heat Box Cover, Single Adj	988291	10-40	12
Assy, Heat Box, Elec, 4 Adjust	988319SRV	10-41	2
Assy, Heat Box, Elec, 4 Adjust	988319SRV	10-42	2
Assy, Heat Box, Elec, Single Adj	987872SRV	10-39	2
Assy, Heat Box, Elec, Single Adj	987872SRV	10-40	2
Assy, Heat Box, Propane, 4 Adjust	988318SRV	10-33	2
Assy, Heat Box, Propane, 4 Adjust	988318SRV	10-34	2
Assy, Heat Box, Propane, Single Adj	851182SRV	10-31	2
Assy, Heat Box, Propane, Single Adj	851182SRV	10-32	2
Assy, Insert, Elec, LH	984305-1	10-41	1
Assy, Insert, Elec, RH, 4	984306-1	10-42	1
Assy, Insert, Electric, 8500, LH	985561SRV	10-39	1
Assy, Insert, Electric, 8500, RH	985562SRV	10-40	1
Assy, Insert, Propane, LH	859394SRV	10-31	1
Assy, Insert, Propane, LH	983409-1SRV	10-33	1
Assy, Insert, Propane, RH	859395SRV	10-32	1
Assy, Insert, Propane, RH, 4	983410-1SRV	10-34	1
Assy, Manual Screw	1003107	10-12	25
Assy, Remote, Electric Flight Screw	852900	10-12	24
Assy, Screed Arm, LH	982743LSRV	10-12	—
Assy, Screed Arm, LH	982743LSRV	10-45	1
Assy, Screed Arm, RH	982743RSRV	10-12	2
Assy, Screed Arm, RH	982743RSRV	10-46	1
Assy, Screed, Citrus, Tank, Elec	987099SRV	10-47	1
Assy, Screed, Citrus, Tank, Propane	985777SRV	10-47	1a
Assy, Slide Adjust	985556	10-33	4
Assy, Slide Adjust	985556	10-34	4
Assy, Slide Adjust	985556	10-41	4
Assy, Slide Adjust	985556	10-42	4
Assy, Tail Piece	1003132	10-22	30
Assy, Tail Piece	1003132	10-24	22
Assy, Tank Fuel	1003288SRV	10-7	7
Assy, Tank Hydraulic	1003117SRV	10-7	5
Assy, Tank, Hyd, Adj	1003117	10-20	15
Assy, Vibrator	855253	10-36	1
Assy, Walk Board	987056	10-37	1
Assy, Weldment, Undercarriage, L.H.	1003072	10-1	15
Assy, Weldment, Undercarriage, R.H.	1003073	10-1	16
Auger	860135	10-5	13A

Description	Part Number	Figure Number	Item Number
Auger Assy, LH	860073	10-5	19
Auger Assy, RH	860083	10-5	17
Auger Cover, Bottom	853410	10-5	24
Auger End Mount, LH 8000/8500	860051HDL SRV	10-5	9A
Auger End Mount, RH 8000/8500	860051HDR SRV	10-5	9
Auger Extension Kit, 24"	982521SRV	10-14	—
Auger Extension Kit, LH	860135	10-14	—
Auger Extension Kit, RH	860136	10-14	8
Auger Extension, LH, 24"	851230SRV	10-14	2A
Auger Extension, RH	860136	10-5	13
Auger Extension, RH, 24"	851229SRV	10-14	2
Auger Section, LH	861150C	10-5	18
Auger Section, RH	861140C	10-5	16
Backup Alarm, Pressure Switch	851504	10-10	26
Ball Joint, .375, Male, w/ Stud	982157	10-8	35
Ball Joint, .375, Male, w/ Stud	982157	10-9	36
Ball, Plunger, .500-13	920095	10-18	23
Ball, Plunger, .500-13	920095	10-19	19
Ball, Plunger, .500-13	920095	10-20	31
Bar Jack, Screed Slide	988556	10-30	12
Bar Jack, Screed Slide	988556	10-35	12
Bar Right Hood Support	988218	10-22	20
Bar Right Hood Support	988218	10-23	20
Bar Right Hood Support	988218	10-24	15
Bar Right Hood Support	988218	10-25	15
Bar, .125 x 2.00 x 44.50, Notches	855562	10-30	13
Bar, .125 x 2.00 x 44.50, Notches	855562	10-35	13
Bar, .250 x 2.00 x 7.00	853593SRV	10-6	29
Bar, .25x1.5x36	985120	10-39	10
Bar, .25x1.5x36	985120	10-40	10
Bar, .25x1.5x36	985120	10-41	12
Bar, .25x1.5x36	985120	10-42	12
Bar, .375 x 1.50 x 42	985121	10-35	8
Bar, .375 x 6.25 x 7.00	853598	10-4	29
Bar, .500 x 1.50 x 2.50 Hole	855921	10-3	—
Bar, 125 x 1.50 x 9.50	853595	10-4	30
Bar, Adjustable Slide	851242SRV	10-15	2
Bar, Conveyor Flight Bar (Quick Change)	851118A	10-3	18
Bar, End Gate Skid 8515	982963	10-43	7
Bar, Guide (Outer)	920041SRV	10-4	23

Illustrated Parts List (IPL)



Description	Part Number	Figure Number	Item Number
Battery, 12V, 1125 CCA	986806	10-22	—
Battery, 12V, 1125 CCA	986806	10-23	—
Battery, 12V, 1125 CCA	986806	10-24	—
Battery, 12V, 1125 CCA	986806	10-25	—
Bearing	850130	10-5	15
Bearing, Auger, Axle, Idler	850130	10-1	34
Bearing, Auger, Axle, Idler	850130	10-3	7
Bearing, Conveyor Pulley/Vibrator Shaft	250150	10-36	7
Bearing, Push Roller (1 1/4")	810110	10-17	13
Bearing, Screed Flight Screw	870030	10-31	5
Bearing, Screed Flight Screw	870030	10-32	5
Bearing, Screed Flight Screw	870030	10-33	5
Bearing, Screed Flight Screw	870030	10-34	5
Bearing, Screed Flight Screw	870030	10-39	5
Bearing, Screed Flight Screw	870030	10-40	5
Bearing, Screed Flight Screw	870030	10-41	5
Bearing, Screed Flight Screw	870030	10-42	5
Bearing, Screed Flight Screw	870030	10-42	3
Bearing, Screed Flight Screw	870030	10-45	3
Bearing, Screed Flight Screw	870030	10-46	3
Bearing, Truck Hitch Roller	930050	10-17	9
Bed Assy, Conveyor	851627SRV	10-3	—
Belly Pan, LH	851127LSRV	10-3	15
Belly Pan, RH	851127RSRV	10-3	16
Belt, Engine, CAT C3.4T	988671-06	10-9	—
Belt, Engine, Kub, Tier3, V3600TB	1001166-05	10-8	—
Block Link	850080A	10-3	14
Block, Terminal	985138-04	10-47	10
Bolt and Nut, Cast Auger	861141	10-5	20
Bolt, Conveyor Drive Chain Adjuster	851148SRV	10-6	2
Bottom Radiator Mount	1002917-02	10-9	2
Bottom Rail, Screed Ext	855783	10-30	10
Bottom Rail, Screed Ext	855783	10-35	10
Bottom Tank	853816	10-4	16
Bracket For SM	988226	10-22	21
Bracket For SM	988226	10-23	21
Bracket For SM	988226	10-24	16
Bracket For SM	988226	10-25	16
Bracket, Air Breather, Kubota	988124	10-22	28
Bracket, Air Breather, Kubota	988124	10-23	28

Description	Part Number	Figure Number	Item Number
Bracket, Air Cleaner Mount	38385-05	10-8	14
Bracket, Air Cleaner Mount	38385-05	10-9	31
Bracket, Depth Screw Control LH	890132LSRV	10-43	6
Bracket, Depth Screw Control RH	890132RSRV	10-44	6
Bracket, Engine Relay	1002917-40	10-9	—
Bracket, Floor Board Mount	853654	10-22	2
Bracket, Floor Board Mount	853654	10-23	2
Bracket, Floor Board Mount	853654	10-24	3
Bracket, Floor Board Mount	853654	10-25	2
Bracket, Grade Control	855568	10-12	22
Bracket, LD	1003168	10-19	1
Bracket, Muffler, LH	1003082-03	10-9	8
Bracket, Muffler, LH	1003082-04	10-9	9
Bracket, Radiator, Top Left	1003082-06	10-9	14
Bracket, Radiator, Top Right	1003082-07	10-9	18
Bracket, Relay Mount	36086	10-9	—
Bracket, Relay Mount	36085	10-28	17
Bracket, Safety Switch	900029	10-20	26
Bracket, Sonic Tracker	851578	10-15	15
Bracket, Sonic Tracker	851578	10-16	17
Bracket, Throttle Mount	1002917-17	10-9	16
Bracket, Valve Lever Mount	910058	10-21	17
Bracket, Water/Fuel Pump Mount	480260	10-11	3
Bracket, Z Arm, TOPCON	9090-1125SRV	10-15	23
Bracket, Z Arm, TOPCON	9090-1125SRV	10-16	11
Breaker, 15 Amp	985140	10-47	8
Breaker, Main	985880	10-49	5
Breather, Track Tensioner Cyl.	851644	10-1	20
Breather, Track Tensioner Cyl.	851644	10-2	26
Bumper Assy, Rad Isolator Mnt	1001166-60	10-8	8
Burner Nozzle, Ignitor	982501	10-13	19
Burner Nozzle, Screed Extension	982503	10-13	20
Burner, Wand, Assy. ST 5 Ignitor	982504	10-13	17
Bushing, 2.00 ID x 2.50 OD x 2.50	810070	10-1	37
Bushing, 2.00 ID x 2.50 OD x 2.50	810070	10-5	8
Bushing, Fiber	988588	10-38	4
Bushing, Track	811314	10-1	26
Bushing, Track Idler/Truck Hitch	810070	10-17	6
Bushing, Track Link, Short	851460	10-1	25
Cable	920136	10-18	4

Illustrated Parts List (IPL)



Description	Part Number	Figure Number	Item Number
Cable 1.0625	851246	10-15	10
Cable J-Box to Control Box	983416-01	10-16	5
Cable, AM Module Only	985866-02	10-15	30
Cable, AM Module Only	985866-02	10-16	9
Cable, Bat, Neg, 2/0, 34"	986802	10-8	—
Cable, Bat, Pos, 2/0, 42"	986801	10-8	—
Cable, Battery	986801	10-8	—
Cable, Battery	986802	10-8	—
Cable, Battery	986804	10-22	—
Cable, Battery	5804	10-22	—
Cable, Battery	986804	10-23	—
Cable, Battery	5804	10-23	—
Cable, Battery	986804	10-24	—
Cable, Battery	5804	10-24	—
Cable, Battery	986804	10-25	—
Cable, Battery	5804	10-25	—
Cable, Battery, Neg, 16", Eye/Eye	1002917-36	10-9	—
Cable, Battery, Pos, 50", Eye/Eye	1002917-35	10-9	—
Cable, Height Locator .188 x 90 w/5.00" Stroke	851520	10-12	10
Cable, Lower Controls	920120	10-22	—
Cable, Lower Controls	920120	10-24	—
Cable, Power, Ultrasonic	982796	10-44	13
Cable, Push Pull	920120	10-18	3
Cable, Push Pull	920136	10-19	2
Cable, Push Pull	920136	10-20	20
Cable, R.H. Drive, Auger & Pump (104" X 3")	920120	10-10	20
Cable, RH Control	920130	10-18	27
Cable, RH Control	920130	10-19	23
Cable, RH Control	920130	10-20	35
Cable, RH Drive, Auger and Pump	920120	10-18	28
Cable, RH Drive, Auger and Pump	920120	10-19	24
Cable, RH Drive, Auger and Pump	920120	10-20	36
Cable, Sonic Sensor Straight	983271	10-43	13
Cap, Fuel Tank, Lockable	140030FL	10-7	9
Cap, Fuel Tank, Lockable	140030FL	10-47	11
Cap, Hyd Tank, Lockable	140030HL	10-7	1
Cap, Radiator	1002917-39	10-9	47
Cap, Radiator, 13.5 Psi, 2.25" Neck	1002184-04	10-8	9
Cap, Valve Spool Cover	141040	10-21	13
Capacitor, Generator, 20 uF	1002146	10-49	—

Description	Part Number	Figure Number	Item Number
Capacitor, Generator, 25 uF	1002147	10-49	—
Capacitor, Generator, 30 uF	1002148	10-49	—
Capacitor, Generator, 40 uF	986658	10-49	—
Capscrew, 1/2-13" X 2 Flat Head Socket	851111	10-17	11
Cartridge Valve, 2-Speed (HPS)	851236	10-7	23
Cartridge Valve, Auto Auger (HPS)	851235	10-7	22
Cartridge Valve, Auto Conveyor (HPS)	851628A-1	10-7	18
Case For Sonic Tracker	851265	10-15	21
Cast Handle	920210-02	10-18	7
Cast Handle, Lower Control	920210A	10-22	—
Cast Handle, Lower Control	920210A	10-24	—
Cast Handle, RH Control (Mod)	920210	10-18	6
Cast Handle, RH Control (Mod)	920210	10-19	7
Cast Track Pad	811304	10-1	22a
Cat C3.4t Tier3	1003082	10-9	—
CAT, Air Primary Filter	38385-01	QR	
CAT, Air Safety Filter	38385-02	QR	
CAT, Fuel Filter	984909-01	QR	
CAT, Oil Filter	988671-04	QR	
Center Auger Support	853403	10-5	23
Center Shield, Conveyor Rear	840162	10-4	9
Chain Guard, Conveyor L.H. Drive	854532SRV	10-6	8
Chain Guard, Conveyor R.H. Drive	853572SRV	10-6	—
Chain Rail, Track Drive	851102	10-1	3
Chain, Conveyor Drive (#80)	851121	10-3	23
Chain, Conveyor Drive (#80)	851121	10-6	4
Chain, Paver Auger Drive	860090	10-5	4
Chain, Roller, 40 x 52 Pitch	870190	10-30	4
Chain, Roller, 40 x 52 Pitch	870190	10-35	4
Chrome Rod	988601	10-38	6
Circuit Breaker, 15 Amp	1003673	10-9	—
Circuit Breaker, 40 Amp	34853	10-9	—
Circuit Breaker, 80 Amp	1001617	10-9	—
Clamp, Element, Screed Ext	985123	10-39	11
Clamp, Element, Screed Ext	985123	10-40	11
Clamp, Element, Screed Ext	985123	10-41	13
Clamp, Element, Screed Ext	985123	10-42	13
Clamp, Hose #4	33277	10-11	—
Clamp, Hose, #28	33169	10-9	—
Clamp, Hose, #4	33277	10-9	—

Illustrated Parts List (IPL)



Description	Part Number	Figure Number	Item Number
Clamp, Muffler Band, 6.62" ID	1002917-27	10-9	23
Clamp, Muffler, .3125 x 2.5	33312	10-8	12
Clamp, Muffler, .3125 x 2.50	33312	10-9	28
Clamp, Muffler, 2"	71172	10-9	24
Clamp, Muffler, Strap, 2.5 SS	1003082-09	10-9	25
Clamp, Plate	854076-1	10-4	15A
Clevis, .188 x .250	851213	10-12	9
Clevis, .250-28	350050	10-18	9
Clevis, .250-28	350050	10-19	4
Clevis, .250-28	350050	10-20	18
Coil Cord, 15ft CA to Tracker	983414-08	10-16	3
Coil Cord, 6s/6s 1.5 to 7.5 ft	983050	10-44	15
Coil, 12V (HPS)	851628A-2	10-7	19
Coil, w/Diode, 12V	851237A	10-7	24
Coiled Cord, Remote TOPCON	986609	10-15	29
Coiled Cord, Remote TOPCON	986609	10-16	21
Coiled Cord, TOPCON Tracker/Slope	851574	10-15	28
Collar, Lock	620400	10-17	5
Collar, Retaining Cap w/ Bolt	851645	10-5	7
Conn, 02-Pin, Plug, DT06-2S	983199	10-9	—
Conn, 02-Pin, Soc, DT04-2p	983198	10-9	—
Conn, 04-Pin, Soc, DTP04-4P	985765	10-9	—
Conn, 12-Pin, SOC, DT04-12P	983207	10-9	—
Conn, Wedge, Plug, 2P, Deutsch	983208	10-9	—
Conn, Wedge, Recp, 12P, Deutsch	983217	10-9	—
Conn, Wedge, Recp, 2P, Deutsch	983209	10-9	—
Conn, Wedge, Recp, 4P, Deutsch	983213	10-9	—
Conveyor Chain, Assy	851117ASRV	10-3	12
Conveyor Mounting Plate With Bearing	851483	10-3	4
Conveyor, Assy. Complete	851626SRV	10-3	—
Cotter Pin, .188 x 2.00 Long	80338	10-6	9
Coupling Assy, Motor To Generator, 28 mm	987894SRV	10-49	—
Coupling Half	854003	10-14	5
Coupling Half, 1.00, Vibrator Shaft	880030	10-36	3
Coupling Half, 3 Jaw, 24 mm	1002454	10-49	—
Coupling Half, Tack Pump Motor	280030	10-36	5
Coupling Half, Weldment	854004	10-14	6
Coupling, 1/4" Pipe	230169	10-13	14
Coupling, 1/4" Pipe	230169	10-13	16
Coupling, Flywheel, Pump Drive	1002917-05	10-9	5

Description	Part Number	Figure Number	Item Number
Cover, Access Hole RH	987633	10-22	13
Cover, Access Hole RH	987633	10-23	13
Cover, Access Hole RH	987633	10-24	12
Cover, Access Hole RH	987633	10-25	12
Cover, Access Hole, Top	987629	10-22	14
Cover, Access Hole, Top	987629	10-23	14
Cover, Air Cleaner	38385-03	10-9	—
Cover, Auger Chain Drive	860043SRV	10-5	6
Cover, Back Panel	930065	10-17	15
Cover, Elements, Screed Base	985124	10-35	6
Cover, Pump Plate	320200	10-10	2
Cover, Right Side SM	988118	10-22	18
Cover, Right Side SM	988118	10-23	18
Cover, Right Side SM	988118	10-24	13
Cover, Right Side SM	988118	10-25	13
Cover, Screed LH Ext Cyl	851204SRV	10-30	15
Cover, Screed LH Ext Cyl	851204SRV	10-35	15
Cover, Screed Plate Access	851201SRV	10-30	14
Cover, Screed Plate Access	851201SRV	10-35	14
Cover, Screed RH Ext Cyl	851203SRV	10-30	16
Cover, Screed RH Ext Cyl	851203SRV	10-35	16
Cover, Top Center	987627	10-22	8
Cover, Top Center	987627	10-23	8
Cover, Top Con Hole	988126	10-25	14
Cover, Valve Inlet	910055	10-21	11
Cover, Valve Outlet	910056	10-21	12
Crown & Valley Assy, Front	870172	10-30	3
Crown & Valley Assy, Front	870172	10-35	3
Crown & Valley Assy, Rear	870182	10-30	2
Crown & Valley Assy, Rear	870182	10-35	2
CSHH, .250 x 2.00	102-9-1A	10-12	18
CSHH, .250-20 x .750	102-3-1A	10-20	27
CSHH, .250-20 x 1.00	102-5-1A	10-6	24
CSHH, .250-20 x 1.00	80185	10-33	19
CSHH, .250-20 x 1.00	80185	10-34	19
CSHH, .250-20X1.0	80185	10-41	19
CSHH, .250-20X1.0	80185	10-42	19
CSHH, .312-18 x 1.00	102-105-1A	10-18	16
CSHH, .312-18 x 1.00	102-105-1A	10-22	36
CSHH, .312-18 x 1.00	102-105-1A	10-23	35

Illustrated Parts List (IPL)



Description	Part Number	Figure Number	Item Number
CSHH, .312-18 x 1.00	102-105-1A	10-24	29
CSHH, .312-18 x 1.00	102-105-1A	10-25	28
CSHH, .312-18 x 1.50	102-107-1A	10-20	13
CSHH, .312-18 x 2.00	102-109-1A	10-20	21
CSHH, .375-16 x .750	851134	10-4	10
CSHH, .375-16 x .750	851134	10-12	16
CSHH, .375-16 x 1.00	102-205-1A	10-7	14
CSHH, .375-16 x 1.00	102-205-1A	10-22	39
CSHH, .375-16 x 1.00	102-205-1A	10-23	38
CSHH, .375-16 x 1.00	102-205-1A	10-24	32
CSHH, .375-16 x 1.00	102-205-1A	10-25	31
CSHH, .375-16 x 2.00	80230	10-33	16
CSHH, .375-16 x 2.00	80230	10-34	16
CSHH, .375-16 x 2.00, GR5	102-209-1A	10-4	32
CSHH, .375-16X2.00	80230	10-41	16
CSHH, .375-16X2.00	80230	10-42	16
CSHH, .375-24 x .750	100-203-1A	10-18	12
CSHH, .375-24 x .750	100-203-1A	10-19	9
CSHH, .375-24 x 1.00, GR5	100-205-1A	10-30	18
CSHH, .375-24 x 1.00, GR5	100-205-1A	10-35	18
CSHH, .375-24 x 1.00, GR8	81068	10-31	14
CSHH, .375-24 x 1.00, GR8	81068	10-32	14
CSHH, .375-24X1.00, GR8	81068	10-39	14
CSHH, .375-24X1.00, GR8	81068	10-40	14
CSHH, .375-28 x 1.00	100-205-1A	10-22	48
CSHH, .375-28 x 1.00	100-205-1A	10-23	47
CSHH, .375-28 x 1.00	100-205-1A	10-24	41
CSHH, .375-28 x 1.00	100-205-1A	10-25	40
CSHH, .437-14 x 1.25, GR5	860048	10-31	17
CSHH, .437-14 x 1.25, GR5	860048	10-32	17
CSHH, .437-14X1.25, GR5	860048	10-39	17
CSHH, .437-14X1.25, GR5	860048	10-40	17
CSHH, .500-13 x 1.00	102-405-1A	10-3	10
CSHH, .500-13 x 1.25	80250	10-8	—
CSHH, .500-13 x 1.25	102-406-1A	10-22	46
CSHH, .500-13 x 1.25	102-406-1A	10-23	45
CSHH, .500-13 x 1.25	102-406-1A	10-24	39
CSHH, .500-13 x 1.25	102-406-1A	10-25	38
CSHH, .500-13 x 1.50	811364	10-1	47
CSHH, .500-13 x 1.50, GR5	102-407-1A	10-4	33

Description	Part Number	Figure Number	Item Number
CSHH, .500-13 x 1.50, GR5	811364	10-10	15
CSHH, .500-13 x 1.75	102-408-1A	10-12	20
CSHH, .500-13 x 2.00	851111	10-3	1
CSHH, .500-13 x 2.00	851111	10-6	6
CSHH, .500-13 x 2.00	102-409-1A	10-22	42
CSHH, .500-13 x 2.00	102-409-1A	10-23	41
CSHH, .500-13 x 2.00	102-409-1A	10-24	35
CSHH, .500-13 x 2.00	102-409-1A	10-25	34
CSHH, .500-13 x 2.50	102-411-1A	10-12	12
CSHH, .500-13 x 2.50	102-411-1A	10-15	7
CSHH, .500-13X0.75	80840	10-43	10
CSHH, .500-13X0.75	80840	10-44	10
CSHH, .625 x 1.25	800282	10-3	24
CSHH, .625-11 x 1.25 GR5	102-606-1A	10-15	25
CSHH, .625-11 x 1.25 GR5	102-606-1A	10-16	15
CSHH, .625-11 x 1.25 GR5	102-606-1A	10-20	11
CSHH, .625-11 x 1.25 GR8	81170	10-1	8
CSHH, .625-11 x 1.25 GR8	81170	10-2	15
CSHH, .625-11 x 1.50	102-607-1A	10-6	18
CSHH, .625-11 x 1.50, GR5	102-607-1A	10-4	35
CSHH, .625-11 x 2.00 GR8	80983	10-1	7
CSHH, .625-11 x 2.00 GR8	80983	10-2	17
CSHH, .625-11 x 2.50	102-611-1A	10-12	14
CSHH, .625-11 x 2.50	102-611-1A	10-15	13
CSHH, .625-11 x 4.00 GR5	102-617-1A	10-15	17
CSHH, .625-11 x 4.00 GR8	102-617-1A	10-16	19
CSHH, .625-11 x 7.50	920229	10-18	26
CSHH, .625-11 x 7.50	920229	10-19	22
CSHH, .625-11 x 7.50	920229	10-20	34
CSHH, .875-9X2.00, GR5	102-809-1A	10-43	5
CSHH, .875-9X2.00, GR5	102-809-1A	10-44	5
CSHH, 1.00-14 x 3.00 GR8	100-913-1A	10-6	14
CSHH, 1.00-14 x 3.50 GR8	100-915-1A	10-6	16
CSHH, 135mm, Track Pad Bolt	983166-06	10-2	—
CSHH, M10-1.50 x 30mm	989272-36	10-2	20
CSHH, M12-1.50 x 40mm	811330	10-1	13
CSHH, M12-1.50 x 50mm	811330A	10-1	11
CSHH, M12-1.50 x 50mm	811330A	10-2	19
CSHH, Track Pad	811308	10-1	30
CSSH, .375-16 Shldr Socket	870279	10-31	6

Illustrated Parts List (IPL)



Description	Part Number	Figure Number	Item Number
CSSH, .375-16 Shldr Socket	870279	10-32	6
CSSH, .375-16 Shldr Socket	870279	10-33	7
CSSH, .375-16 Shldr Socket	870279	10-34	7
CSSH, .375-16 Shldr Socket	870279	10-39	6
CSSH, .375-16 Shldr Socket	870279	10-40	6
CSSH, .375-16 Shldr Socket	870279	10-41	7
CSSH, .375-16 Shldr Socket	870279	10-42	7
CSSH, .375-16 x .750	102-203-1A	10-6	11
CSSH, .500-13 x 1.75	80503	10-2	23
CSSH, .500-13 x 2.00, GR5	851111	10-4	34
CSSH, .500-20X1.50	100-408-1	10-38	9
CSSH, .625 x 1.00	851652	10-3	32A
CSSH, .625 x 2.00	851653	10-3	29A
Curly Cord	900082	10-12	—
Cutoff Left Side	851153SRV	10-6	22
Cutoff Right Side	851154SRV	10-6	23
Cyl, Hyd, 2.00X12.00/30.00X1.25	851191	10-48	1
Cyl, Hyd, 2.00X12.00/30.00X1.25	851192	10-48	2
Cyl, Hyd, Track Tensioner	811331	10-1	19
Cyl, Hyd, Track Tensioner	980607-01	10-2	9
Cyl. Hyd. 2.00 x 8.00	840030	10-4	3
Cylinder, Arm Extension	930070	10-17	16
Cylinder, Hopper Lift	840020	10-4	18
Decal, Height	851215	10-12	11
Deflector, Left Side (High Deck)	850038LSRV	10-3	26
Deflector, Right Side (High Deck)	850038RSRV	10-3	—
Depth Screw Assy, Screed	890092SRV	10-43	3
Depth Screw Assy, Screed	890092SRV	10-44	3
Detent Kit	901007	10-21	8
Door, Engine Access	987626	10-22	16
Door, Engine Access	987626	10-23	16
Double Row Chain Assembly (50-2)	900404	10-14	7
Drive Cplg, Tandem Pump	851160-2	10-10	25
Drive Cplg. Charge Pump	851160-1	10-10	8
Drive Shaft, Conveyor	851116	10-3	8
Dual Grade & Slope	988288SRV	10-16	—
Dual Grade Control	988409SRV	10-16	—
Ears, Pivot	851210SRV	10-12	6
Elbow, Rubber, 90, 2.25 ID	1003082-08	10-9	46
Elbow, Rubber, 90, 3.50 x 3.00	986537-29	10-9	43

Description	Part Number	Figure Number	Item Number
Element, Heater, Screed, 40"	987890SRV	10-39	9
Element, Heater, Screed, 40"	987890SRV	10-40	9
Element, Heater, Screed, 40"	987890SRV	10-41	11
Element, Heater, Screed, 40"	987890SRV	10-42	11
Element, Heater, Screed, 46"	987886SRV	10-35	9
End Cap, For Auger	851647	10-5	10
End, Adjuster End	1003333SRV	10-12	26
End, Motor End of Screw	851212	10-12	8
End, Rod End of Screw	851211	10-12	7
Engine Cover	988117	10-22	12
Engine Cover	988117	10-23	12
Engine Cover	988117	10-24	11
Engine Cover	988117	10-25	11
Engine Mount, Rear, Kub	988673-14	10-8	40
Engine, Kubota, 85.5HP, Tier 3	1003139	10-8	—
Exhaust, Elbow with Flange	1003082-02	10-9	6
Exhaust, Nipple, Kub	1003139-01	10-8	42
Exhaust, Tip 90 Kubota	986537-26	10-8	—
Exhaust, Tip 90°	986537-26	10-9	29
Ext Adj Screw Assy	851185SRV	10-31	4
Ext Adj Screw Assy	851185SRV	10-32	4
Ext Adj Screw Assy	851185SRV	10-33	6
Ext Adj Screw Assy	851185SRV	10-34	6
Ext Adj Screw Assy	851185SRV	10-39	4
Ext Adj Screw Assy	851185SRV	10-40	4
Ext Adj Screw Assy	851185SRV	10-41	6
Ext Adj Screw Assy	851185SRV	10-42	6
Ext. Burner Pipe	851600-1	10-31	19
Ext. Burner Pipe	851600-1	10-32	19
Ext. Burner Pipe	851600-1	10-33	20
Ext. Burner Pipe	851600-1	10-34	20
Extension, 6' Left Side	851634LSRV	10-26	3
Extension, 6' Right Side	851634RSRV	10-26	4
Extension, Front Bumper	852664	10-1	51
Extension, Screed Arm	851206SRV	10-12	1
Fan Guard	986537-44	10-8	30
Fan Shroud	986537-40	10-8	27
Fan, Engine, Puller	1003082-13	10-9	4
Fan, Kubota	986537-19	10-8	19
Filler Neck	140030FN	10-7	2

Illustrated Parts List (IPL)



Description	Part Number	Figure Number	Item Number
Filter Element, Air Primary	38385-01	10-9	—
Filter Element, Air Secondary	38385-02	10-9	—
Filter Element, Fuel	982080-02	10-8	—
Filter Element, Fuel/Water	984909-01	10-9	41
Filter Oil, Kubota	986537-03	10-8	—
Filter, Element, Charge/Return	290030	10-7	13
Filter, Fuel, In Line	986537-31	10-8	—
Filter, Head, Charge/Return	290010	10-7	12
Filter, Hydraulic	36123	10-7	6
Filter, Oil, CAT 3044T	988671-03	10-9	—
FITT	5406-12-8	10-1	42
Fitt, 45 12MJ-16MB	38203	10-9	—
FITT, 90 02Mp-05Hb	988673-18	10-8	—
Fitt, 90 04MP-05HB	38279	10-9	—
FITT, 90 06MJ-08MP	34536	10-11	13
Fitt, 90 06MJ-M14, Metric O-ring	1003082-10	10-9	—
FITT, 90 10MJ-08MB	6801-10-8	10-1	39
Fitt, 90 12MJ-16MB	71771	10-9	—
Fitt, Cap 06FP	1003082-11	10-9	—
Fitt, Str 02MBSTP-02FP	984909-10	10-9	—
Fitt, Str 02MP-02MP, Brass	37331	10-9	—
FITT, Str 02Mp-05Hb	988673-19	10-8	—
Fitt, Str 02MP-05HB	988673-19	10-9	—
Fitt, Str 04FP-05MB	1002917-25	10-9	—
Fitt, Str 06MP-o6HB, Push On	31959	10-9	—
FITT, Str 08MP-08MB	6401-8-8	10-1	41
FITT, Str 10MJ-08MB	6400-10-8	10-1	40
Fitt, Tee 02FP-02FP-02FP	1002917-24	10-9	—
FITT, Test 04MP-02PD	72371	10-21	22
Fitting Grease, Str., .250-28	140610	10-5	14
Flange, Shroud	987632	10-8	—
Flange, Shroud	987632	10-22	25
Flange, Shroud	987632	10-23	25
Flashing, Center, Front Lip	985063SRV	10-4	28
Flashing, Side Strip Front Lip	985062SRV	10-4	13
Flight Screw Assy	1002728SRV	10-45	2
Flight Screw Assy	1002728SRV	10-46	2
Float Positioner Kit	141050	10-21	7
Float, Assembly Screed	910054FLS	10-20	—
Flow Divider Screed	851689	10-7	25

Description	Part Number	Figure Number	Item Number
Frame Body	Reference	10-6	27
Front Lip Clamp	985581	10-4	31
Fuel Gauge	1002033	10-27	3
Fuse, 20 Amp, ATC	36342	10-28	1
Fuse, 20 Amp, ATC	36342	10-28	2
Fuse, 20 Amp, ATC	36342	10-28	3
Fuse, 20 Amp, ATC	36342	10-28	4
Fuse, 20 Amp, ATC	36342	10-28	5
Fuse, 20 Amp, ATC	36342	10-28	8
Fuse, 20 Amp, ATC	36342	10-28	9
Fuse, 20 Amp, ATC	36342	10-28	10
Fuse, 20 Amp, ATC	36342	10-28	11
Fuse, 20 Amp, ATC	36342	10-28	12
Fuse, 20 Amp, ATC	36342	10-28	13
Fuse, 20 Amp, ATC	36342	10-28	14
Fuse, 20 Amp, ATC	36342	10-28	15
Fuse, 20 Amp, ATC	36342	10-28	16
Fuse, 25 Amp, ATC	37303	10-28	7
Fuse, 5 Amp, ATC	36746	10-28	6
Gauge, 3 in 1: Tach, Oil, Water Temp	1002032	10-27	1
Gauge, L.P.G. Pressure	230110	10-13	3
Generator, Hyd., Assy	987893	10-49	1
Generator, Only	988176	10-49	2
Glow Plug, Kub, Tier3, V3600TB	1001166-09	10-8	—
Grating, Walkboard	853823	10-22	6
Grating, Walkboard	853823	10-23	6
Grating, Walkboard	853823	10-24	7
Grating, Walkboard	853823	10-25	6
Grill, Top Center	988208	10-22	9
Grill, Top Center	1003306	10-22	26
Grill, Top Center	988208	10-23	9
Grill, Top Center	1003306	10-23	26
Group, Screed Base, Elec	989377SRV	10-35	1
Group, Screed Base, Propane	1000251	10-30	1
Guard, Belt, Kub, V3600TB	1001166-40	10-8	3
Guard, LH Screed Ext Hinge	851180LSRV	10-31	16
Guard, LH Screed Ext Hinge	851180LSRV	10-33	15
Guard, LH Screed Ext Hinge	851180LSRV	10-39	16
Guard, LH Screed Ext Hinge	851180LSRV	10-41	15
Guard, RH Screed Ext Hinge	851180RSRV	10-32	16

Illustrated Parts List (IPL)



Description	Part Number	Figure Number	Item Number
Guard, RH Screed Ext Hinge	851180RSRV	10-34	15
Guard, RH Screed Ext Hinge	851180RSRV	10-40	16
Guard, RH Screed Ext Hinge	851180RSRV	10-42	15
Guard,Fan Rd 18.625 2.00"DI	1002917-03	10-9	3
Guide Bar Assy	920032SRV	10-4	22
Guide Wheel, Truck Hitch	930055	10-17	10
Hair Pin Cotter, .177	870307	10-1	18
Hair Pin Cotter, .177	870307	10-2	13
Hair Pin Cotter, .177	870307	10-4	5
Half Link, Conveyor Chain w/Pin, Cotter	850215A	10-3	17
Hand Grip, Flight/Depth Screw	870276	10-42	4
Hand Grip, Flight/Depth Screw	870276	10-43	17
Hand Grip, Flight/Depth Screw	870276	10-44	17
Hand Grip, Flight/Depth Screw	870276	10-45	4
Hand Grip, Flight/Depth Screw	870276	10-46	4
Handle & Nozzle, Spraydown	920220	10-11	8
Handle, Bolt, .625-11	300060	10-15	24
Handle, Bolt, .625-11	300060	10-16	14
Handle, Cord and Switch One	920238	10-12	—
Handle, Drive, LH	920097L	10-18	18
Handle, Drive, LH	920097L	10-19	14
Handle, Drive, LH	920097L	10-20	2
Handle, Drive, RH	920097R	10-18	19
Handle, Drive, RH	920097R	10-19	15
Handle, Drive, RH	920097R	10-20	3
Handle, Vertical	910060	10-21	20
Harness, CAT, Paver	1002917-13	10-9	19
Harness, Electric Heat, Gen. to Bulkhead	985826	10-49	7
Harness, Engine, V3600TB Kubota	988673-17	10-8	—
High Volume Pump, Augers And Conveyors	984483	10-10	10
Hinge Assembly	1002735	10-41	3
Hinge Assembly	1002736	10-42	3
Hinge Assy	1002735	10-33	3
Hinge Assy	1002736	10-34	3
Hinge, (2) Thru Holes	987639	10-22	17
Hinge, (2) Thru Holes	987639	10-23	17
Hinge, (2) Thru Holes	987639	10-24	20
Hinge, (2) Thru Holes	987639	10-25	20
Hinged Panel, L/H	840157SRV	10-4	20
Hinged Panel, R/H	840156SRV	10-4	21

Description	Part Number	Figure Number	Item Number
Hold Down	802112SRV	10-4	8
Hopper Wing Assy, LH	851146SRV	10-4	2
Hopper Wing Assy, RH	851145SRV	10-4	1
Hose Assy Track RH Tensioner	8550B	10-1	49
Hose Clamp, 2 1/8" (Size 28)	230240	10-13	18
Hose Clamp, 2.125 (Size 28)	230240	10-8	—
Hose Kit 8515 Truck Hitch	984399	10-17	—
Hose Reel, Machine Washdown	920200	10-11	1
Hose, 15'	984339	10-11	10
Hose, 15'	984339	10-11	12
Hose, Ignitor Burner	230034	10-13	23
Hose, L.P.G. Regulator to Tee	230032	10-13	6
Hose, Pump to Hose Reel, 5'	984338	10-11	6
Hose, Radiator, Lower, CAT	1002917-21	10-9	20
Hose, Radiator, Lower, Kub	1001166-15	10-8	2
Hose, Radiator, Upper	986537-21	10-8	20
Hose, Radiator, Upper	1002917-12	10-9	12
Hose, Screed Burner	230034	10-13	7
Hose, Screed Extension Burner	230038	10-13	10
Hose, Screed Extension Burner	851225	10-13	13
Hourmeter Gauge	1002035	10-27	5
Housing, Front Slide Bar	851243SRV	10-15	4
Housing, Guide Bar (Inner)	920051SRV	10-4	24
Housing, Rear Slide Bar	851241SRV	10-15	1
Hyd. Cyl., Cutoff	910170	10-6	21
Hyd. Cyl., Screed Lift (1000c / 8000c / 8500)	851436	10-6	12
Hyd. Motor, Auger	987903	10-5	1
Hyd. Motor, Conveyor Main	1001027	10-3	21
Hyd. Motor, Conveyor Main	1001027	10-6	1
Hyd. Motor, Screed Vibrator	983405	10-36	6
Hydraulic, Element	984594-01	QR	
Hydraulic, Filter - 2 Required	36123	QR	
Hydraulic, Charge Filter Return	290030	QR	
Idler, Conveyor Chain Front	850120	10-3	28
Idler, Track Front	1001589	10-1	14
Idler, Track Front	983530	10-2	11
Ignition Key, Replacement	982008-04	10-27	—
Ignition Switch w/Heat Start	39146-14	10-27	12
Ignition Switch w/Heat Start	39146-14	10-27	19
Ignitor, Ceramic, Hot Surface	230024	10-13	22

Illustrated Parts List (IPL)



Description	Part Number	Figure Number	Item Number
Inlet Cover, V-20 (w/Relief)	910055	10-20	—
Inlet Hood	1003139-05	10-8	44
Inlet Hood	1002917-29	10-9	32
Insert, 3-Jaw Coupling	280040	10-36	4
Instrument Panel Dash	Reference	10-20	—
Intake, Tube, Kub	1003139-02	10-8	22
Isolator	986537-14	10-9	21
Isolator,	986537-14	10-8	16
Isolator, Rad Lower Mnt	1001166-59	10-8	7
Isolator, Rad Upper Mnt	1001166-57	10-8	5
Isolator, Rubber Mnt, .375 Thread	1002917-32	10-9	35
Jointer Assy, 8500, LH	851682	10-43	1
Jointer Assy, 8500, RH	851683	10-44	1
Key, Vandalism Cover	35560	10-22	—
Key, Vandalism Cover	35560	10-23	—
Key, Vandalism Cover	35560	10-24	—
Key, Vandalism Cover	35560	10-25	—
Kit, AM Module with Remote	987053SRV	10-15	—
Kit, Auger Cover Closing	860043-1SRV	10-5	12
Kit, Hose Oil Drain Kubota	988169	10-8	—
Kit, Spraydown Pump and Strainer	1001428SRV	10-11	—
Knob, Round Ball, .375-16 x R1.375	851156	10-20	24
Knob, Round Ball, .500-13 x R1.875	920225	10-18	20
Knob, Round Ball, .500-13 x R1.875	920225	10-19	16
Knob, Round Ball, .500-13 x R1.875	920225	10-20	4
Kubota, Air Primary Filter	38385-01	QR	
Kubota, Air Safety Filter	38385-02	QR	
Kubota, Fuel Filter	982080-02	QR	
Kubota, In-line Filter	986537-31	QR	
Kubota, Oil Filter	986537-03	QR	
L.P.G. Tank, 20 lbs	230010	10-13	1
Lever, Fastener	980460	10-22	27
Lever, Fastener	980460	10-23	27
Lever, Fastener	980460	10-24	23
Lever, Fastener	980460	10-25	23
Light, Green, Dash, .500 Hole	31985	10-27	20
Light, Red, Dash, .500 Hole	31983	10-27	2
Light, Red, Dash, .500 Hole	31983	10-47	3
Link Assy, Valve Lever	901010	10-21	18
Link Kit, Track Repair	811312	10-1	24

Description	Part Number	Figure Number	Item Number
Link w/Tab Conveyor Chain Inner	850080B	10-3	19
Link, Master w/Pins	850070A	10-3	13
Link, Only H/D 135mm Chain	983166-03	10-2	—
Linkage	900075	10-3	38
Linkage, Controls	1003119	10-20	7
Locking Bar, Crown And Valley	988376	10-30	5
Locking Bar, Crown And Valley	988376	10-35	5
M10 lock washer	80478	10-8	—
M10 x 1.25 x 16 mm socket head cap screw	811301	10-8	—
M10 x 1.25 x 20 mm bolt w/ captive lock washer	Reference	10-8	—
M10 x 1.25 x 25 mm bolt	81132	10-8	—
M10 x 1.25 x 30 mm hex head	80920	10-8	—
M12 x 1.25 x 35mm bolt	Reference	10-8	—
M16 x 2.00 x 60 mm bolt	Reference	10-8	—
M8 x 1.25 nut	80471	10-8	—
M8 x 1.25 x 16 mm bolt w/ captive lock washer	81291	10-8	—
M8 x 1.25 x 22 mm bolt w/ captive lock washer	80486	10-8	—
Main Valve Bank	Reference	10-20	10
Manifold, Auto Auger/ 2-Speed (HPS)	850001	10-7	21
Manifold, Auto Conveyor (HPS)	851628A	10-7	17
Manifold, Generator, w/Flow Control	986992	10-49	8
Manifold, Side Wing	910122	10-7	10
Manifold, Track Tensioner	851544	10-1	43
Manual, CAT, C3.4, Ops and Maint	1002917-33	10-9	—
Manual, Operators, Kub, V3600TB	1001166-42	10-8	—
Manual, Parts, Kub, V3600TB	1001166-45	10-8	—
Manual, Service, Kub, V3600TB	1001166-43	10-8	—
Manual, Workshop. Kub, V3600TB	1001166-44	10-8	—
Master Link, 60H	860049	10-5	4A
Micro Switch, Auto. Conveyors	900050	10-3	36
Motor, Hyd, Drive, 2 Speed	811362	10-1	44
Motor, Hyd, Drive, 2 Speed	811362	10-2	3
Motor, Hyd, Generator	986994	10-49	3
Mount, Cable, RH	988122	10-18	2
Mount, Conveyor Drive Motor	851149SRV	10-6	3
Mount, Engine, Left Rear	1002917-16	10-9	15
Mount, Engine, Right Rear	1002917-11	10-9	11
Mount, Front Engine and Radiator	1002917-10	10-9	10
Mount, Main Valve, LH	1003159	10-21	1
Mount, Motor Lf Kubota	986537-16	10-8	17

Illustrated Parts List (IPL)



Description	Part Number	Figure Number	Item Number
Mount, Motor Rf Kubota	986537-17	10-8	18
Mount, Pivot	851209SRV	10-12	4
Mount, RH Controls, HD	1003504	10-18	1
Mounting Bracket, Auger Motor	860021	10-5	3
Mounting Plate 6" Electric Screw, LH	853585SRV	10-12	—
Mounting Plate 6" Electric Screw, RH	853586SRV	10-12	23
Muffler	986537-35	10-8	26
Muffler	986537-35	10-9	22
Muffler Brace, Kubota Engine	988673-10	10-8	36
Muffler Strap, Engine	986537-30	10-8	25
Nipple, .375	99638	10-11	5
Nozzle, Spraydown Handle	901210A	10-11	9
Nut	900078	10-3	41
Nut	900027	10-10	18
Nut, .375-16 Lock	143-3	10-33	9
Nut, .375-16 Lock	143-3	10-34	9
Nut, .375-16 Lock	143-3	10-41	9
Nut, .375-16 Lock	143-3	10-42	9
Nut, .437-14 Hex	116-4	10-31	18
Nut, .437-14 Hex	116-4	10-32	18
Nut, .437-14 Hex	116-4	10-39	18
Nut, .437-14 Hex	116-4	10-40	18
Nut, .500-13 Hex	116-5	10-6	7
Nut, .750-10 UNC Hex Jam	116-8-1	10-43	4
Nut, .750-10 UNC Hex Jam	116-8-1	10-44	4
Nut, .875-9 Hex	116-9	10-43	8
Nut, .875-9 UNC-2B Nylon Lock	987396	10-31	15
Nut, .875-9 UNC-2B Nylon Lock	987396	10-32	15
Nut, .875-9 UNC-2B Nylon Lock	987396	10-39	15
Nut, .875-9 UNC-2B Nylon Lock	987396	10-40	15
Nut, .875-9 UNC-2B Nylon Lock	987396	10-44	8
Nut, Coil Retainer (HPS)	851628-3	10-7	20
Nut, Hex 1"	116-10	10-14	4
Nut, Hex, .312-18	116-2	10-20	23
Nut, Hex, .500-13	116-5	10-22	45
Nut, Hex, .500-13	116-5	10-23	44
Nut, Hex, .500-13	116-5	10-24	38
Nut, Hex, .500-13	116-5	10-25	37
Nut, Hex, Heavy, .625-11	117-5	10-4	37
Nut, Hex, Track Pad	983166-05	10-2	—

Description	Part Number	Figure Number	Item Number
Nut, Jam, .375-16	116-3-1	10-20	25
Nut, Jam, .500-13	116-5-1	10-18	21
Nut, Jam, .500-13	116-5-1	10-19	17
Nut, Jam, .500-13	116-5-1	10-20	29
Nut, Jam, .625-11	116-7-1	10-18	30
Nut, Jam, .625-11	116-7-1	10-19	26
Nut, Jam, .625-11	116-7-1	10-20	38
Nut, Lock 1.00-8	116-10	10-12	13
Nut, Lock, .250	116-1	10-12	19
Nut, Lock, .375	143-3	10-22	41
Nut, Lock, .375	143-3	10-23	40
Nut, Lock, .375	143-3	10-24	34
Nut, Lock, .375	143-3	10-25	33
Nut, Lock, .375-16	143-3	10-4	40
Nut, Lock, .500	115-5-A	10-12	21
Nut, Lock, .500-13	143-5	10-15	5
Nut, Lock, .625-11	116-7	10-12	15
Nut, Lock, .625-11	116-7	10-15	14
Nut, Lock, 1.00-14	1002464	10-6	15
Nut, Track Pad Cap Screw	811309	10-1	31
O-Ring,	320235	10-10	9
O-Ring, Hyd. Motor	811366	10-1	46
O-Ring, Hyd. Motor	811366	10-2	22
Outlet Cover, V-20 (w/PB Sleeve)	910056	10-20	—
Pin	851132	10-4	4
Pin, Clevis	350080	10-21	19
Pin, Clevis, .250 x .875	350080	10-18	10
Pin, Clevis, .250 x .875	350080	10-19	5
Pin, Clevis, .250 x .875	350080	10-20	17
Pin, Cotter (.250)	900079	10-3	42
Pin, Cotter, .094 x .750	960019	10-18	11
Pin, Cotter, .094 x .750	960019	10-19	6
Pin, Cotter, .094 x .750	960019	10-20	19
Pin, Cylinder	210060	10-48	3
Pin, Hydraulic Cylinder	240030	10-4	19
Pin, Hydraulic Cylinder	240030	10-6	20
Pin, Male, 16-20 AWG, Deutsch	988821-09	10-9	—
Pin, Pivot Side Panel	854084SRV	10-4	14
Pin, Push Bar Swivel	810081SRV	10-1	38
Pin, Roll Pin (.375 x 2.00)	851118-1	10-3	20

Illustrated Parts List (IPL)



Description	Part Number	Figure Number	Item Number
Pin, Track Link, Master	811306	10-1	28
Pin, Track Link, Master, Heavy Duty	983166-04	10-2	—
Pin, Track Link, Plain	811307	10-1	27
Pipe Nipple, 1/4" Pipe	99593	10-13	15
Pipe, Exhaust, Flexible	1002917-07	10-9	7
Pipe, Screed Burner, Med	851197-1	10-30	19
Pivot Mount, TOPCON/Spectra Physics	851575SRV	10-15	22
Pivot Mount, TOPCON/Spectra Physics	851575SRV	10-16	13
Plate, Air Cleaner Mount	1002924	10-9	40
Plate, Air Cleaner Mount	1002924	10-24	19
Plate, Air Cleaner Mount	1002924	10-25	19
Plate, Bottom Engine	853669	10-22	5
Plate, Bottom Engine	853669	10-23	5
Plate, Bottom Engine	853669	10-24	6
Plate, Bottom Engine	853669	10-25	5
Plate, Cable Control Mount	1003082-05	10-9	42
Plate, Cable Control Mount	1003082-05	10-10	4
Plate, Conveyor Flap	853645	10-22	1
Plate, Conveyor Flap	853645	10-23	1
Plate, Conveyor Flap	853645	10-24	2
Plate, Conveyor Flap	853645	10-25	1
Plate, Cover	980751	10-22	7
Plate, Cover	980751	10-23	7
Plate, Cover	980751	10-24	8
Plate, Cover	980751	10-25	7
Plate, Cut Off Cylinder Mount	853497	10-6	28
Plate, Cut Off Gusset	853596	10-6	30
Plate, Cutoff Cylinder Mount	851152	10-6	17
Plate, Fuel Pump Brkt, Chalv kub	1002184-17	10-8	10
Plate, Pump, Mnt, Kub, Tier3	1001166-11	10-8	1
Plate, Rad Isolator Mnt	1001166-58	10-8	6
Plate, Throttle Lever, CAT	1002917-18	10-9	17
Plate, Vibrator Housing	880071	10-36	9
Plug, Hole Cover, Rad Shroud	1001166-56	10-8	4
Power Beyond Sleeve	901002	10-21	14
Power Cable, Ultra Sonic	982796	10-43	15
Power Cord, Bulkhead to Control Box	985138-03	10-47	12
Power Cord, Bulkhead to Control Box	985138-03	10-49	6
Pressure Switch (Flowjet Pump)	851448	10-11	11
Pump Drive Plate, Flywheel	851479	10-10	1

Description	Part Number	Figure Number	Item Number
Pump, Fuel, Electric, Kubota	1002184-18	10-8	11
Pump, L.&R. Drive Sun Strand	320416	10-10	11
Pump, Spraydown	1001542	10-11	2
Push Roller Assy, Swivel	984283SRV	10-1	33
Push Roller, Truck Wheel	810102	10-17	12
Quick Disconnect Coupling	230084	10-13	21
Radiator Brace	986537-45	10-8	31
Radiator Cover	987635	10-22	15
Radiator Cover	987635	10-23	15
Radiator Support Plate	986537-43	10-8	29
Radiator Support Plate Foot	986537-42	10-8	28
Radiator/Cooler Assy, Kub	988673-13	10-8	39
Radiator/Oil Cooler Combo	1002917-01	10-9	1
Reducer, 3.5 x 3.0	37163	10-8	23
Reducing Elbow, 3.0 x 2.5	34030	10-8	21
Regulator w/Gauge, L.P.G.	982515	10-13	5
Relay, 12VDC, DPST ,25 AMP, N/O	985141	10-47	9
Relay, 12VDC, SPDT, 40 Amp, 5 Pin	36085	10-9	—
Relay, 12VDC, SPDT, 40 Amp, 5 Pin	36086	10-28	18
Relay, 12VDC, SPST, 100 Amp, HD	985751	10-9	—
Relay, Time Delay, Off, 10 Amp	988231	10-47	7
Relief Valve, Side Wing Manifold	910122-1	10-7	11
Remote Pod, Ultra Sonic	982795	10-43	14
Remote Pod, Ultra Sonic	982795	10-44	14
RH Pivot, F/R Lever	920094	10-18	22
RH Pivot, F/R Lever	920094	10-19	18
RH Pivot, F/R Lever	920094	10-20	30
Rnd, .688 x 43.50, CRS	854447	10-31	8
Rnd, .688 x 43.50, CRS	854447	10-32	8
Rnd, .688 x 43.50, CRS	854447	10-33	10
Rnd, .688 x 43.50, CRS	854447	10-34	10
Rnd, .688x43.50, CRS	854447	10-39	8
Rnd, .688x43.50, CRS	854447	10-40	8
Rnd, .688x43.50, CRS	854447	10-41	10
Rnd, .688x43.50, CRS	854447	10-42	10
Rod & Chain, Guide Bar	920061SRV	10-4	25
Rod, Control Handles, 12.00	988202	10-18	8
Rod, Control Handles, 12.00	988202	10-19	8
Roll Up Curb Attachment, Left Side, 12"	851635LSRV	10-26	5
Roll Up Curb Attachment, Left Side, 24"	851636LSRV	10-26	5

Illustrated Parts List (IPL)



Description	Part Number	Figure Number	Item Number
Roll Up Curb Attachment, Right Side, 12"	851635RSRV	10-26	6
Roll Up Curb Attachment, Right Side, 24"	851636RSRV	10-26	6
Roller	930040	10-17	7
Roller Assy, Push Bar, w/Brgs and Shaft	980032	10-1	35
Roller Extension, Bumper	930060	10-17	14
Roller, Conveyor Chain Guide, w/ Bearing	850162	10-3	31
Roller, Extension Bumper	980035	10-1	50
Rubber, Front Lip, Center	985058	10-4	27
Rubber, Front Outer	985057	10-4	12
Safety Prop, Hopper	987264SRV	10-4	17
Scraper, Conveyor	851128SRV	10-3	33
Screed Citrus Tank and Electric Heat Control Box		10-29	1
Screed Endgate Assembly LH		10-29	11
Screed Endgate Assembly RH		10-29	5
Screed Extension Single Adjuster LH		10-29	14
Screed Extension Single Adjuster RH		10-29	15
Screed Frame Non-Sloping		10-29	9
Screed Miscellaneous Components		10-29	6
Screed Miscellaneous Components		10-29	7
Screed Pull Arm and Remote Control Box LH		10-29	10
Screed Pull Arm and Remote Control Box RH		10-29	4
Screed Slide Plate Assembly		10-29	12
Screed Slide Plate Assembly		10-29	13
Screed Vibrator Assembly		10-29	2
Screed Walk Board Assembly		10-29	8
Screed, 8500B, Low Deck, 8' to 15', Electric	982823SRV	10-30	—
Screed, 8500B, LP, 8' to 15'	982824SRV	10-30	—
Screw, Electric (6.00")	851518	10-12	5
Screws	900076	10-3	39
Seal	Reference	10-49	4
Seal Kit	980607-02	10-2	—
Seal Kit Universal For 2.00 Cylinder	851484	10-4	—
Seal Kit Universal, Hopper Wing	870311	10-4	—
Seal Kit, Cyl, Hyd, 2.00X12.00/30.00X1.25	851191-01	10-48	—
Seal Kit, Cyl, Hyd, 2.00X12.00/30.00X1.25	851191-01	10-48	—
Seal Kit, Hyd. Cyl.	811331-01	10-1	21
Seal Kit, Hyd. Cyl. 2.00 x 1.00	851436-01	10-6	—
Seal Kit, Hyd. Cyl. 2.50 x 1.25	910170-01	10-6	—
Seal Kit, Hyd. Motor	1001027-01	10-3	—
Seal Kit, Hyd. Motor	860012	10-5	22

Description	Part Number	Figure Number	Item Number
Seal Kit, Hyd. Motor	1001027-01	10-6	—
Seal Kit, Relief Valve	910065	10-21	—
Seal Kit, Valve Section	910062	10-21	9
Seal Kit, Valve Spool	910059	10-21	10
Seal, Hyd Motor/Pump	851489A	10-1	45
Seal, Hyd Motor/Pump	851489A	10-2	25
Seal, New Style Front Sundstrand	851489A	10-10	13
Seat Assy W / Armrest, White	360010	10-37	3
Section, Valve (Augers (Detented))	910052	10-20	—
Section, Valve (Cylinders) (Spring Return)	910054	10-20	—
Selector Valve, Conveyor	910120	10-17	—
Selector Valve, Conveyor	910120	10-20	9
Selector Valve, Vibrator	910080	10-20	8
Sender, Press, 0-100 PSI, 02MP	1002917-27	10-9	—
Sender, Temp, 100-250 F, 06MP	1002917-28	10-9	—
Sending Unit, Fuel Tank	140040	10-7	8
Sending Unit, Water Temp, Kubota	986537-50	10-8	—
Sensor, Oil Pressure, 300 Kubota	989707	10-8	—
Sensor, Ultra Sonic	982794	10-43	16
Sensor, Ultra Sonic	982794	10-44	16
Set Screw	850170	10-3	35
Set Screws	851645-1	10-5	11
Shaft w/ Sprocket, Cast Auger	861130C	10-5	5
Shaft, Bumper Roller	930075	10-17	17
Shaft, Conveyor Front Idler	851124	10-3	30
Shaft, New Style	851495A	10-10	12
Shaft, Push Bar Roller	980034	10-1	36
Shaft, Vibrator Eccentric	880062	10-36	8
Shield, 8500 Center Conv.	851133	10-4	7
Shield, Auger Extension (LH)	851228SRV	10-14	1A
Shield, Auger Extension (RH)	851227SRV	10-14	1
Shield, Corner Rubber	851147A	10-4	15
Shield, Front Support	985669SRV	10-4	11
Shroud	987630	10-22	24
Shroud	987630	10-23	24
Side Wing Cylinder Bushing	930041	10-4	—
Sight Gauge, Hyd. Oil Temp/Level	500070	10-7	4
Skid	851249SRV	10-15	6
Slide Plate Assembly	1002181	10-38	2
Slide Plate Assembly with Chrome Rods	1002186	10-38	1

Illustrated Parts List (IPL)



Description	Part Number	Figure Number	Item Number
Slope Cable 5 Foot	983414-14	10-16	6
Slope Meter	851421	10-15	27
Slope Sensor	983414-13	10-16	7
SM Driver Side	988116	10-22	31
SM Driver Side	988116	10-24	24
Snap Ring	851256	10-38	5
Snap Ring, Conveyor Drive Shaft	850040	10-3	9
Snap Ring, Conveyor Drive Shaft	850040	10-3	27
Solenoid Valve, 12 Volt L.P.G.	230300	10-13	4
Solenoid, Fuel w/ Diodes	1000867-10	10-8	—
Sonic Auger Kit	851696SRV	10-5	—
Sonic Tracker	851579	10-15	19
Spacer, Track Link Bushing	811310	10-1	29
Spherical Rod End, w/ Stud	920090	10-10	19
Spherical Rod End, w/ Stud	920090	10-18	29
Spherical Rod End, w/ Stud	920090	10-19	25
Spherical Rod End, w/ Stud	920090	10-20	37
Spray Down Pump, Strainer	36926	QR	
Spring Center Kit	901014	10-21	6
Spring, Tension	851245	10-15	9
Sprocket, Auger Drive Motor	860030	10-5	2
Sprocket, Auger Shaft	860035	10-5	21
Sprocket, Conveyor Drive Motor	851120	10-3	22
Sprocket, Conveyor Drive Motor	851120	10-6	5
Sprocket, Inner Drive C-188	850030	10-3	6
Sprocket, Outer Dr. C-188	851474SRV	10-3	5
Sprocket, Outer Drive	851473	10-3	3
Sprocket, Track Drive	1003052	10-1	5
Sprocket, Track Drive, 17 Tooth	980670	10-2	5
Starter, CAT C3.4T	988671-09	10-9	—
Starter, Kub, Tier3, V3600TB	1001166-03	10-8	—
Stop Rubber, (Scraper)	410070	10-3	34
Strainer	36926	10-11	7
Strainer & Gasket Kit	140030GK	10-7	3
Strike Off, Left Side, 12"	860091LSRV	10-26	1
Strike Off, Left Side, 24"	860095LSRV	10-26	1
Strike Off, Right Side, 12"	860091RSRV	10-26	2
Strike Off, Right Side, 24"	860095RSRV	10-26	2
Strobe Light, Amber	211748-02	10-22	32
Strobe Light, Amber	211748-02	10-23	31

Description	Part Number	Figure Number	Item Number
Strobe Light, Amber	211748-02	10-24	25
Strobe Light, Amber	211748-02	10-25	24
Support, Auger Adjustable	851231SRV	10-14	3
Support, Pivot Bar	930015	10-17	1
Support, Seat H/D	920024	10-37	5
Switch, Battery Disconnect	SW29	10-22	35
Switch, Battery Disconnect	SW29	10-23	34
Switch, Battery Disconnect	SW29	10-24	28
Switch, Battery Disconnect	SW29	10-25	27
Switch, Neutral Safety	900020	10-20	28
Switch, Push Button	982249	10-27	15
Switch, Push Button	982249	10-47	4
Switch, Temp, 240F .250 NPT	1002917-22	10-9	—
Switch, Toggle	900030	10-27	16
Switch, Toggle	900030	10-27	17
Switch, Toggle, 3 Pos Rev. DPDT MO	900080	10-12	—
Switch, Toggle, 3-Pos, Rev-DPDT, MOM	900080	10-27	18
Switch, Toggle, SPST, 2-POS	851391	10-27	6
Switch, Toggle, SPST, 2-POS	851391	10-27	7
Switch, Toggle, SPST, 2-POS	851391	10-27	8
Switch, Toggle, SPST, 2-POS	851391	10-27	9
Switch, Toggle, SPST, 2-POS	851391	10-27	10
Switch, Toggle, SPST, 2-POS	851391	10-27	11
Switch, Toggle, SPST, 2-POS	851391	10-27	13
Switch, Toggle, SPST, 2-POS	851391	10-27	14
Switch, Toggle, SPST, 2-POS	851391	10-27	21
Switch, Toggle, SPST, 2-POS	851391	10-47	5
Tab, Auger Valve Reverse Lockout	852648	10-21	21
Tab, Conveyor Chain Weld On	851118-2	10-3	—
Tail Piece Bolt On	1003240	10-25	22
Tail, Piece Bolt On	1003240	10-23	30
Tank, Coolant Recovery, Kubota	1001166-13	10-8	—
Tee, .375	920222	10-11	4
Tee, 1/4" Pipe	230080	10-13	8
Tee, 1/4" Street	230081	10-13	9
Term. Battery, POS. Remote Mount	985518	10-22	34
Term. Battery, POS. Remote Mount	985518	10-23	33
Term. Battery, POS. Remote Mount	985518	10-24	27
Term. Battery, POS. Remote Mount	985518	10-25	26
Terminal Block, 10 Gang	987982	10-28	19

Illustrated Parts List (IPL)



Description	Part Number	Figure Number	Item Number
Throttle Bracket, Actuator, Kub	988673-11	10-8	37
Throttle Mount, Actuator, Kub	988673-12	10-8	38
Thumb Screw, .375 -16 x 1.00	920070	10-18	15
Thumb Screw, .375 -16 x 1.00	920070	10-19	11
Thumb Screw, .375-16 x 1.00	920070	10-4	26
Thumb Screw, .375-16 x 1.00	920070	10-15	3
Thumb Screw, .375-16 x 1.00	920070	10-16	12
Tilt Screw, Jointer Assy	890081SRV	10-43	12
Tilt Screw, Jointer Assy	890081SRV	10-44	12
Timer, Elec	985142	10-47	6
Toeboard	988115	10-22	11
Toeboard	988189	10-23	11
Toeboard	988115	10-24	1
Toeboard	988189	10-25	10
Tool Box	851169	10-37	6
Top Rail, Screed Ext	855784	10-30	11
Top Rail, Screed Ext	855784	10-35	11
Torque Hub, 47.6:1, w/Brake	986807	10-1	4
Torque Hub, 47.6:1, w/Brake	986807	10-2	4
Track Assy, Cast	851101	10-1	—
Track Assy, One Side	983166	10-2	—
Track Assy, One Side, w/Poly Pads	851101P	10-1	2
Track Pad, Poly	851104	10-1	22
Track Pad, Poly, Heavy Duty	983166-02	10-2	27
Track Roller, B/1	851566	10-1	9
Track Roller, B/1	851566	10-2	8
Track Roller, B/O	811326	10-1	12
Track Roller, B-1, Inner Flange	983588	10-2	14
Track, Rubber, Continuous	982585	10-2	12
Truck Hitch Assembly	1000253SRV	10-17	—
TSD 3 Conn SS Paver Box	983414-02	10-16	4
TSD Sonic Tracker II	983414-01	10-16	2
Tube Assy, Conveyor Rear Drive	851651	10-3	32
Tube Assy, Conveyor Front Chain Guide	851123	10-3	29
Tube, 2.25 Air Intake, CAT	1003082-12	10-9	44
Tube, Inlet Air	1003139-04	10-8	43
Tube, Inlet Air	1003139-04	10-9	27
U-Bolt, .375-16	350060	10-18	5
U-Bolt, .375-16	350060	10-19	3
U-Bolt, .375-16	350060	10-20	16

Description	Part Number	Figure Number	Item Number
U-Bolt, 3/8"	350060	10-10	21
Umbrella	920235	10-37	—
Undercarriage Complete, Rubber, LH	980607L	10-2	1
Undercarriage Complete, Rubber, RH	980607R	10-2	2
Vacuator Valve, Air Cleaner	38385-04	10-9	—
Valve & Plug, Anticavitation	141020	10-21	16
Valve Assy, 9 Section, w/Float	851161	10-21	2
Valve Section, Detented	910052	10-21	4
Valve Section, Float	910054FLS	10-21	5
Valve Section, Spring Return	910054	10-21	3
Valve, Main Relief	901009	10-21	15
Valve, Relief, Conveyor Manifold (HPS)	851628A-3	10-7	16
Valve, Selector (Cutoff)	230070	10-13	11
Vandalism Box Cover	1002923	10-20	6
Vibrator Housing	855535	10-36	2
Volts Gauge	1002034	10-27	4
W/M Control Tube Support	1003287	10-20	5
W/M, Left Controls M Drive	1003121	10-20	1
W/M, RH Drive Controls	1003113	10-18	14
W/M, RH Drive Controls	1003113	10-19	13
W/M, RH Engine Cover, w/Defl	1000850	10-22	10
W/M, RH Engine Cover, w/Defl	1000850	10-23	10
W/M, RH Engine Cover, W/Defl	1000850	10-24	10
W/M, RH Engine Cover, W/Defl	1000850	10-25	9
Walk Board Brkt	985163	10-37	2
Walkboard Assy, 8500 Lower, LH	851176LSRV	10-37	7
Walkboard Assy, 8500 Lower, RH	851176RSRV	10-37	8
Washer, Bevel, .625	490080	10-18	25
Washer, Bevel, .625	490080	10-19	21
Washer, Bevel, .625	490080	10-20	33
Washer, Counter Sunk	851112	10-17	18
Washer, Counter Sunk, .500	851112	10-3	2
Washer, Fender (.250)	860036	10-6	26
Washer, Fender .375	119-3	10-12	17
Washer, Fender, .375	981511	10-8	15
Washer, Fender, .375 x 2.00	981511	10-8	45
Washer, Flat, .312	120-2	10-22	38
Washer, Flat, .312	120-2	10-23	37
Washer, Flat, .312	120-2	10-24	31
Washer, Flat, .312	120-2	10-25	30

Illustrated Parts List (IPL)



Description	Part Number	Figure Number	Item Number
Washer, Flat, .375	120-3	10-22	40
Washer, Flat, .375	120-3	10-23	39
Washer, Flat, .375	120-3	10-24	33
Washer, Flat, .375	120-3	10-25	32
Washer, Flat, .500	120-5	10-10	—
Washer, Flat, .500	119-5	10-22	43
Washer, Flat, .500	119-5	10-23	42
Washer, Flat, .500	119-5	10-24	36
Washer, Flat, .500	119-5	10-25	35
Washer, Flat, .500	119-5	10-38	7
Washer, Flat, .625	119-7	10-18	24
Washer, Flat, .625	119-7	10-19	20
Washer, Flat, .625	119-7	10-20	32
Washer, Flat, SAE, .375	119-3	10-4	39
Washer, Flat, SAE, .500	80695	10-8	—
Washer, Flat, SAE, .625	81201	10-1	6
Washer, Flat, SAE, .625	81201	10-2	16
Washer, Flat, SAE, .625	119-7	10-15	16
Washer, Flat, SAE, .625	119-7	10-15	26
Washer, Flat, SAE, .625	119-7	10-16	16
Washer, Flat, SAE, .625	119-7	10-16	18
Washer, Flat, SAE, 1.00	119-10	10-4	6
Washer, Lock	900077	10-3	40
Washer, Lock, .250	118-1	10-6	25
Washer, Lock, .250	118-1	10-33	18
Washer, Lock, .250	118-1	10-34	18
Washer, Lock, .250	118-1	10-41	18
Washer, Lock, .250	118-1	10-42	18
Washer, Lock, .312	118-2	10-18	17
Washer, Lock, .312	118-2	10-20	14
Washer, Lock, .312	118-2	10-20	22
Washer, Lock, .312	118-2	10-22	37
Washer, Lock, .312	118-2	10-23	36
Washer, Lock, .312	118-2	10-24	30
Washer, Lock, .312	118-2	10-25	29
Washer, Lock, .375	118-3	10-6	10
Washer, Lock, .375	118-3	10-7	15
Washer, Lock, .375	118-3	10-18	13
Washer, Lock, .375	118-3	10-19	10
Washer, Lock, .375	118-3	10-30	17

Description	Part Number	Figure Number	Item Number
Washer, Lock, .375	118-3	10-31	13
Washer, Lock, .375	118-3	10-32	13
Washer, Lock, .375	118-3	10-35	17
Washer, Lock, .375	118-3	10-39	13
Washer, Lock, .375	118-3	10-40	13
Washer, Lock, .375	119-4	10-41	17
Washer, Lock, .375	119-4	10-42	17
Washer, Lock, .500	118-5	10-1	48
Washer, Lock, .500	118-5	10-2	24
Washer, Lock, .500	118-5	10-3	11
Washer, Lock, .500	118-5	10-4	38
Washer, Lock, .500	80164	10-8	—
Washer, Lock, .500	118-5	10-10	14
Washer, Lock, .500	118-5	10-22	44
Washer, Lock, .500	118-5	10-23	43
Washer, Lock, .500	118-5	10-24	37
Washer, Lock, .500	118-5	10-25	36
Washer, Lock, .500	118-5	10-38	8
Washer, Lock, .500	80164	10-43	9
Washer, Lock, .500	118-5	10-44	9
Washer, Lock, .625	118-7	10-3	25
Washer, Lock, .625	118-7	10-4	36
Washer, Lock, .625	118-7	10-6	19
Washer, Lock, .625	118-7	10-20	12
Washer, Lock, 1.00	118-10	10-6	13
Washer, Lock, M10	320142	10-2	21
Washer, Lock, M12	811328	10-1	10
Washer, Lock, M12	811328	10-2	18
Washer, Lock, SAE, .375	119-4	10-33	17
Washer, Lock, SAE, .375	119-4	10-34	17
Washer, Lock, .375	118-3	10-22	47
Washer, Lock, .375	118-3	10-23	46
Washer, Lock, .375	118-3	10-24	40
Washer, Lock, .375	118-3	10-25	39
Washer, Seal, AL, .636 ID x .813 OD	1002917-23	10-9	—
Wear Plate Assy, Electric	987216SRV	10-35	7
Wear Plate, 8' Bullnose	981724SRV	10-30	7
Wear Plate, Auger Back	856781	10-6	31
Wear Plate, End Gate, 8515	982963SRV	10-44	7
Weldment Undercarriage, Rubber Track, LH	980606L	10-2	7

Illustrated Parts List (IPL)



Description	Part Number	Figure Number	Item Number
Weldment Undercarriage, Rubber Track, RH	980606R	10-2	6
Wire Bail, Temperature	851581	10-15	20
Wiring, Element, Heater Pigtail	985699-03	10-35	9a
Wiring, Element, Heater Pigtail	985699-03	10-39	9a
Wiring, Element, Heater Pigtail	985699-03	10-40	9a
Wiring, Element, Heater Pigtail	985699-03	10-41	11a
Wiring, Element, Heater Pigtail	985699-03	10-42	11a
Work Light	160040A	10-22	33
Work Light	160040A	10-23	32
Work Light	160040A	10-24	26
Work Light	160040A	10-25	25
Yoke, Track Idler	811329A	10-1	17
Yoke, Track Idler	811329A	10-2	10

LeeBoy



VT LeeBoy

A company of VT Systems

500 Lincoln County Parkway Ext.

Lincolnton, North Carolina 28092

Phone: (704) 966-3300 - Fax Sales: (704) 483-5802

www.leeboy.com

Printed in the U.S.A.