



Operations, Service, and Parts Manual



LEEBOY MODEL 8515E CONVEYOR PAVER

Manual No. 1017255-02

This manual applies to
Serial Number 195172
and above.

SAFETY

1

INFORMATION AND SPECIFICATIONS

2

COMPONENT LOCATION

3

OPERATION

4

MAINTENANCE

5

SCHEMATICS

6

ILLUSTRATED PARTS LIST

7

Disclaimer

All information, illustrations and specifications in this manual are based on the latest information available at the time of publishing. The illustrations used in this manual are intended as representative reference views only. Moreover, because of our continuous product improvement policy, we may modify information, illustrations and/or specifications to explain and/or exemplify a product, service or maintenance improvement. We reserve the right to make any change at any time without notice. VT LeeBoy, Inc., VT LeeBoy, LeeBoy, and Rosco are all the same entity and are used interchangeably.

Title 40, Code of Federal Regulations (CFR) 1068

This product meets certified-emission requirements set by the EPA (Environmental Protection Agency), governed by Title 40 CFR 1068, which specifies actions that are prohibited by law and lists civil penalties for noncompliance. As part of those regulations, modification or rendering inoperative any emission-related component can subject you to government penalties (and void your warranty). Tampering with emission controls is in violation of federal law, and can result in civil penalties of up to \$3,750 each day an engine or piece of equipment is operated in violation.

Please be aware that you are responsible for maintaining the machine and the certified emission engine installation. Failure to comply to comply could result in penalties as listed above and void the warranty on this engine and this machine.

For more information, visit: <https://www.epa.gov/laws-regulations/regulations>

California Proposition 65 Warning

Diesel engine exhaust and some of its constituents are known to the State of California to cause cancer, birth defects, and other reproductive harm.

Battery posts, terminals and other related accessories contain lead and lead compounds, chemicals known to the State of California to cause cancer and other reproductive harm. Wash hands after handling.

©2018 VT LeeBoy, Inc.

LeeBoy reserves all copyright and other rights in this manual and the manual's content. No part of this manual may be reproduced or used in any way without the written permission of VT LeeBoy, Inc., except as necessary to operate LeeBoy equipment.

TABLE OF CONTENTS

	Page
Safety Precautions	1-4
Machine Precautions.	1-7
Hot Material Precautions.	1-7
Hydraulic Systems Precautions	1-7
Refueling Precautions	1-8
Battery Precautions	1-8
Starting and Stopping Precautions.	1-8
Parking Precautions	1-8
Operating Precautions.	1-8
Poor Visibility	1-9
Storage Precautions.	1-9
Maintenance Precautions	1-9
Safety Decals	1-10
Safety Decals Care	1-11
Decal Installation (Sticker Type)	1-11
Decal Installation (Top Protected)	1-11
Limited Warranty Policy	2-2
Contact Information	2-3
Specification Charts	2-4
Torque Specifications	2-7
Standard Inch Fasteners.	2-7
Metric Fasteners.	2-8
Hydraulic Fittings	2-8
Determining Proper Torque	2-9
Component Location	3-1
Components Overview	3-3
Dual Operator Platforms	3-3
Augers.	3-4
Hopper and Conveyors	3-4

Screed	3-4
Hydraulic System	3-4
Electrical System	3-4
Machine Overview	3-5
Operation Controls.	3-6
Steering and Speed Control Box	3-8
Electric Heat Controls	3-8
Screed Controls	3-9
Remote Screed Controls.	3-10
Operation	4-1
General Information	4-3
Hopper and Screed Lock Pins	4-3
Receiving the Machine	4-3
Initial and Daily Inspection	4-3
Start-Up Procedure	4-4
Stopping the Engine	4-4
DPF Regeneration (REGEN)	4-4
PV480 Powerview Display	4-5
Gauge Screen	4-5
Soft Keys (Buttons)	4-5
Set Points and Throttle Speed	4-6
Main Menu Screen.	4-7
Diagnostics	4-8
System Info	4-9
Lamp Info	4-9
User Settings	4-10
Regeneration Messages.	4-12
Regen Cautions and Warnings.	4-14
Status Icons	4-17
Plus One Controller	4-18
Driving the Paver.	4-18
Activate/Deactivate Operator Control Station.	4-19
Steering and Speed Control	4-19
Paver Operation	4-20
Spray Down	4-20
Heating the Screed	4-21

Hopper Wings	4-22
Conveyors	4-23
Under Auger Material Cut-Offs	4-23
Electric Flight Screw	4-24
Set the Screed Extension, Flight Screw and Endgate	4-24
Sonic Auger Sensor	4-26
Starting to Pave	4-27
Basic Paving	4-28
Setting the Crown	4-28
Mat Texture Adjustment	4-29
Unloading and Loading	4-30
Unloading	4-30
Loading	4-30
Tie-Down Procedure	4-31
Optional Components	4-31
Auger Extensions Option	4-31
Umbrella Option	4-31
Steering Wheel Option	4-32
Truck Hitch Attachment Option	4-32
HD815 (Heavy Duty) Screed	4-33
Heated Endgates	4-34
Rubber or Steel Track Options	4-34
Topcon® Sonic and Dual Grade Control	4-34
Screed Sloping Extensions	4-34
One-Foot Screed Extension	4-35
Tunnel Extension	4-35
Maintenance	5-1
Maintenance Schedule	5-3
Raising and Lowering Conveyor	5-4
Routine Maintenance	5-5
Preparing Paver for Maintenance	5-5
Every 10 Hours or Daily Routine Maintenance	5-5
Every 50 Hours or Weekly Routine Maintenance	5-5
Every 100 Hour or Monthly Maintenance	5-6
Every 250 Hours or Quarterly Routine Maintenance	5-6
Every 500 Hours or Semi-Annual Routine Maintenance	5-6

Every 1000 Hours or Annual Routine Maintenance	5-6
Torque Hub Lubrication	5-6
Lubrication Points	5-7
Maintenance Adjustments	5-8
Conveyor Flight Chains	5-8
Conveyor Drive Chain	5-8
Auger Drive Chain Adjustment	5-9
Screed Extension Top Guide Adjustment	5-9
Track Tension Pressure Relief	5-10
Conveyor Switch Adjustment	5-10
Torque Hub Hydraulic Motor Gear Adjustments	5-12
Engine Maintenance	5-12
Check Engine Lubrication Oil	5-13
Change Engine Oil and Filter	5-13
Change Air Filter	5-14
Fuel System	5-14
Fuel Tank	5-14
Change Fuel Filter	5-15
Fuel Water Separator	5-16
Hydraulic System	5-16
Check Hydraulic Oil	5-16
Change Hydraulic Oil and Filter	5-17
Electrical System.	5-18
Battery Servicing.	5-18
Alternator	5-19
Electric Heat Control Box.	5-19
Generator	5-21
Generator Capacitor.	5-21
Replacement Procedures	5-22
Front Idler	5-22
Track Tension Cylinder	5-22
Track Rollers	5-22
Track Sprocket (Steel or Poly)	5-23
Rubber Track (Option)	5-23
Torque Hub	5-24
Two-Speed Hydraulic Motors	5-24

Rear Conveyor Shaft, Bearings and Sprockets	5-26
Conveyor Drive Motors.	5-26
Auger Inner Bearings	5-27
Auger Motors	5-28
Main Screed Wear Plate	5-29
Screed Extension Wear Plate	5-30
Conveyor Switch Replacement.	5-31
Replace Radiator Hoses	5-31
Winterizing for Storage.	5-32
Weldment	5-33
Troubleshooting	5-34
Spraydown Pump	5-35
Hydraulic Motor Installation Start-Up Procedure	5-36
Hydraulic Test Ports	5-37
Auger and Conveyor Chain Tension Adjustment	5-38
Troubleshooting Chart	5-39
PV480 Diagnostic Trouble Code (DTC) Chart.	5-41
PV480 Troubleshooting	5-49
Plus One Controller	5-50
Plus One Blink Fault Codes	5-50
Schematics	6-1
Main Harness (1 of 6)	6-3
Main Harness (2 of 6).	6-5
Main Harness (3 of 6)	6-7
Main Harness (4 of 6)	6-9
Main Harness (5 of 6)	6-11
Main Harness (6 of 6)	6-13
Control Box Assembly (1 of 3).	6-15
Control Box Assembly (2 of 3)	6-17
Control Box Assembly (3 of 3)	6-19
C4 Dash to Pedestal Jumper Harness	6-21
C3 Dash to Pedestal Jumper Harness	6-23
Screed 4-Switch Control Box Assembly - Left	6-25
Screed 4-Switch Control Box Assembly - Right.	6-27
Screed Heat Control Box Assembly (1 of 2)	6-29
Screed Heat Control Box Assembly (2 of 2).	6-31

Upper Manifold Harness	6-33
Lower Manifold Harness	6-35
Hydraulic Cooler Harness	6-37
Generator Valve Adapter Harness	6-39
Load Control box to Bulkhead Harness.	6-41
Bulkhead to Generator Harness	6-43
Joystick Control Box	6-45
Electronic Steering Cord	6-47
Hydraulic Schematic - Propel Circuit (1 of 5)	6-49
Hydraulic Schematic - Cylinders circuit (2 of 5)	6-51
Hydraulic Schematic - Vibrator Circuit (3 of 5)	6-53
Hydraulic Schematic - Generator Circuit (4 of 5)	6-55
Hydraulic Schematic - Augers & Conveyors Circuit (5 of 5)	6-57
Illustrated Parts List	7-1
Quick Reference	7-5
Track Assembly - Poly Pads/Cast Steel (1 of 2)	7-6
Track Assembly - Poly Pads/Cast Steel (2 of 2)	7-8
Track Assembly - Continuous Rubber	7-10
Push bar Assembly.	7-12
Conveyor Assembly (1 of 2).	7-14
Conveyor Assembly (2 of 2).	7-16
Conveyor Drive & Paddle Assembly (1 of 2)	7-18
Conveyor Drive & Paddle Assembly (2 of 2).	7-20
Hopper Wings	7-22
Rear Auger Assembly (1 of 2)	7-24
Rear Auger Assembly (2 of 2)	7-26
Fuel Tank Assembly	7-28
Hydraulic Tank Assembly.	7-30
Hydraulic Test Ports	7-32
Engine Assembly - Radiator	7-34
Engine Assembly - Intake/Exhaust	7-36
Engine Assembly - Components (1 of 2).	7-38
Engine Assembly - Components (2 of 2)	7-40
Engine Assembly - Pumps	7-42
Hoods and Covers - Left	7-44
Hoods and Covers - Right	7-46

Spray Down	7-48
Tow Point Assembly	7-50
Hydraulic Manifold - Upper	7-52
Hydraulic Manifold - Lower	7-54
Hydraulic Oil Cooler	7-56
Generator	7-58
Hydraulic Cylinders	7-60
Dash Assembly - Controls	7-62
Dash Assembly - Mounting	7-64
Control Box Assembly (1 of 2).	7-66
Control Box Assembly (2 of 2)	7-68
Seat Assembly & Details	7-70
HD Screed Overview - Sloping and Non-Sloping	7-72
HD Screed Frame Assembly (1 of 2)	7-74
HD Screed Frame Assembly (2 of 2)	7-76
HD Screed Extension Assembly - Left	7-78
HD Screed Extension Assembly - Right.	7-80
HD Screed Slide Plate Assembly	7-82
HD Screed Pull Arm Assembly - Left	7-84
HD Screed Pull Arm Assembly - Right	7-86
HD Screed Thickness Adjuster - Standard	7-88
HD Screed Endgates.	7-90
HD Screed Vibrators and Walkboards	7-92
HD Screed Citrus Tank.	7-94
HD Screed Control Assembly	7-96
Option - HD Berm Screed Overview	7-98
Option - HD Berm Screed Ext. Assembly - Left (1 of 2).	7-100
Option - HD Berm Screed Ext. Assembly - Left (2 of 2)	7-102
Option - HD Berm Screed Ext. Assembly - Right (1 of 2).	7-104
Option - HD Berm Screed Ext. Assembly - Right (2 of 2).	7-106
Option - HD Berm Screed Remote Assembly	7-108
Option - HD 3:1 Depth Screws (1 of 2).	7-110
Option - HD 3:1 Depth Screws (2 of 2).	7-112
Option - HD Screed Heated Endgates	7-114
Option - HD Screed Heated Safety Edge Endgates.	7-116
Option - HD Miscellaneous Options	7-118

Table of Contents

Option - Legend Non-Sloping Screed Overview7-120
Option - Legend Sloping Screed Overview7-122
Option - Legend Non-Sloping Screed Frame Assembly.7-124
Option - Legend Sloping Screed Frame Assembly7-126
Option - Legend Screed Extension Single Adjust - Left7-128
Option - Legend Screed Extension Single Adjust - Right7-130
Option - Legend Screed Extension 4-Way Adjust - Left7-132
Option - Legend Screed Extension 4-Way Adjust - Right7-134
Option - Legend Screed Slide Plates7-136
Option - Legend Screed Pull Arm Assembly - Left.7-138
Option - Legend Screed Pull Arm Assembly - Right7-140
Option - Legend Screed Endgate - Left.7-142
Option - Legend Screed Endgate - Right7-144
Option - Legend Screed Citrus Tank7-146
Option - Legend Screed Power Crown7-148
Option - Dual Steering Wheels7-150
Option - 12" Auger Extension7-152
Option - 24" Auger Extension.7-154
Option - Curb Attachments7-156
Option - 20' Paver Leveling Ski Assembly.7-158
Option - 30'-40' Paver Leveling Ski Assembly7-160
Option - TopCon P-32 Control Assembly7-162
Option - Truck Hitch Assembly7-164
Option - Umbrella & Fire Extinguishers7-166
Hydraulic Hose Schedule - Standard Unit.7-168
Alphabetical Parts Index7-170

Thank you for purchasing the LeeBoy Model 8515E Conveyor Paver. We wish you many years of safe and efficient operation of your LeeBoy product.

READ THIS MANUAL PRIOR TO OPERATING the machine. It is an important part of the machine and should be kept with in the dedicated storage container provided at all times. Though you may be familiar with similar equipment, you **MUST** read and understand this manual before operating the machine to help prevent injury or damage.

This manual is intended as a guide for the safe and efficient use of your machine, including procedures for proper operation and maintenance. Use it with all related supplemental books, engine, transmission manuals, and any other manuals supplied by other manufacturers. Related Service Bulletins should also be reviewed to provide information regarding some of the recent changes. If any questions arise concerning this publication or to order a replacement manual, contact your authorized LeeBoy dealer.

This manual contains information that was available at the time of printing and is subject to change without notice.

Section 1 - Safety: Contains general and specific safety guidelines for product and safety label locations.

Section 2 - Information and Specifications: Contains warranty, contact information, machine specification tables, and machine dimensions.

Section 3 - Component Location: Contains overview of major component locations and functions.

Section 4 - Operation: Contains instructions for safe operation and information for optional equipment.

Section 5 - Maintenance: Contains routine maintenance procedures, mechanical adjustments, component replacement and troubleshooting charts for common problems and corrections. (For specific engine maintenance procedures, refer to the engine manufacturer manual.)

Section 6 - Schematics: Contains electrical and hydraulic schematics for product functionality.

Section 7 - Illustrated Parts List (IPL): Contains parts numbers and illustrations for serviceable components.



VT LeeBoy, Inc. is proud to be ISO 9001 certified. The International Standards Organization (ISO) establishes guidelines to ensure that products and services are safe, reliable and of good quality. ISO certifies companies who demonstrate compliance with all aspects of product safety, customer satisfaction, efficiency, environmental stewardship and social responsibility. Our teams work hard to deliver quality industrial machines that exceed customer expectations and we strive for continuous improvement in everything we do. The VT LeeBoy family of companies is committed to total quality management with a strong focus on meeting customer needs.



VT LeeBoy, Inc., is also proud to be an accredited ANAB manufacturer, which is a certification process comprised of quality standards established by the American National Standards Institute (ANSI) and the American Society for Quality (ASQ). The ANSI-ASQ National Accreditation Board plays an important role in ensuring the safety and quality of goods and services, along with protecting the environment.

NOTES

Section 1

SAFETY

	Page
Safety Precautions	1-4
Machine Precautions.	1-7
Hot Material Precautions.	1-7
Hydraulic Systems Precautions	1-7
Refueling Precautions	1-8
Battery Precautions	1-8
Starting and Stopping Precautions.	1-8
Parking Precautions	1-8
Operating Precautions.	1-8
Poor Visibility	1-9
Storage Precautions.	1-9
Maintenance Precautions	1-9
Safety Decals	1-10
Safety Decals Care	1-11
Decal Installation (Sticker Type)	1-11
Decal Installation (Top Protected)	1-11

NOTES

This manual provides important information to familiarize you with safe operating and maintenance procedures. Even though you may be familiar with similar equipment, read and understand this manual before operating the LeeBoy Model 8515E Conveyor Paver and follow its instructions when operating the machine.

Safety is everyone's business and our top concern. Knowing the guidelines covered in this section will help ensure your safety, the safety of those around you, as well as proper paver operation.

Keep safety labels in good condition. If safety labels become missing or damaged, replace them with new matching labels. Replacement safety labels are available from your LeeBoy authorized dealer (see contact information in **Section 2**).

You can find more information about occupational health and safety in the paving industry on the internet. A few resources are listed below:

www.osha.gov

cdc.gov

www.asphaltpavement.org

www.safety.fhwa.dot.gov/

LOOK FOR THESE SYMBOLS THROUGHOUT THIS MANUAL. THESE ITEMS ARE EXTREMELY IMPORTANT FOR THE SAFETY OF YOU AND YOUR COWORKERS. READ AND UNDERSTAND THOROUGHLY. HEED THE WARNINGS AND FOLLOW THE INSTRUCTIONS.

 **DANGER** Indicates a hazardous situation which, if not avoided, *will* result in death or serious injury.

 **WARNING** Indicates a hazardous situation which, if not avoided, *could* result in death or serious injury.

 **CAUTION** Indicates a hazardous situation which, if not avoided, *could* result in minor or moderate injury.

 **NOTICE** Indicates a situation which can cause damage to the equipment, personal property and/or the environment, or cause the machine to operate improperly.

NOTE: Indicates a procedure, practice or condition that should be followed in order for the machine or component to function in the manner intended.

Safety

SAFETY PRECAUTIONS

CAUTION

The safety messages that follow have CAUTION level hazards.



Pre-Operation Hazard

Read and understand this Operation Manual before operating or servicing the engine to ensure that safe operating practices and maintenance procedures are followed.

- Never permit anyone to service or operate the machine without proper training.
- Safety signs and labels are additional reminders for safe operating and maintenance techniques.
- Contact LeeBoy or an authorized LeeBoy dealer for additional training.
- Make sure you are aware of all laws and regulations that are in effect for the location in which the paver is operated.
- Make sure you have all necessary licenses to operate the paver.
- Never operate a unit in need of repair.
- Ensure all covers are installed.

Poor Lighting Hazard



The work area must be well lit to ensure safe and proper operation.

- Ensure that the work area is adequately illuminated.
- Always install wire cages on portable safety lights.

Tool Hazard

Always use tools appropriate for the task at hand and use the correct size tool for loosening or tightening LeeBoy machine parts.

DANGER

The safety messages that follow have DANGER level hazards.

Power Lines Hazard

If your machine comes into contact with electric power lines, observe the following:

- Stay in the operators seat.
- Warn other workers to stay away and do not touch any control or any part of the machine.
- If contact can be broken, drive the machine away from the danger zone.
- If contact cannot be broken, stay in the operators seat until told that power is off.
- Failure to observe these directions could result in electrocution or death.

Electrocution Hazard

Disconnect the battery before welding anywhere on the machine.

Suffocation Hazard



Carbon monoxide poisoning is a serious condition that occurs as a result of improper ventilation.

- Never operate the internal combustion engine on this machine in an enclosed area with poor ventilation. Ensure proper ventilation to reduce risk of carbon monoxide poisoning or death.

Exhaust Hazard



All internal combustion engines create carbon monoxide gas during operation and special precautions are required to avoid carbon monoxide poisoning:

- Never block windows, vents or other means of ventilation.
- Always ensure that all connections are tightened to specifications after repair is made to the exhaust system.

WARNING

The safety messages that follow have WARNING level hazards.

Crush Hazard

Keep bystanders away from work area before and during operation.

Modification Hazard

Never modify the LeeBoy machine without the written consent of LeeBoy. Any modification can affect the safe operation of the paver and may cause personal injury or death.

Exposure Hazard



Operators of the paver must be aware of their work environment and the equipment needed to work safely.

- Always wear personal protective equipment, including appropriate clothing, gloves, work shoes, and protection for eyes and ears, as required by the task at hand.

Explosion Hazard



While the engine is running or the battery is charging, hydrogen gas is being produced and can be easily ignited. Keep the area around the battery well-ventilated and keep sparks, open flame, and any other form of ignition out of the area.

- Always disconnect the negative (-) battery cable before servicing the paver.
- Do not start the engine by shorting the starter circuit or any other starting method not stated in this manual. Only use the starting procedure as described in this manual to start the engine.
- Never charge a frozen battery. Always slowly warm the battery to room temperature before charging.

Fire and Explosion Hazard

- Diesel fuel is flammable and explosive under certain conditions.
- Never use a shop rag to catch fuel.
- Wipe up all spills immediately.
- Never refuel with the engine running.
- Store any containers containing fuel in a well-ventilated area, away from any combustibles or sources of ignition.

Fire Hazard



When operating machinery there is a risk for fire. Always have appropriate safety equipment available.

- Keep a charged fire extinguisher within reach when working in an environment where a fire may occur.
- Have all fire extinguishers checked periodically for proper operation and/or readiness.
- Always read and follow safety-related precautions found on containers of hazardous substances like parts cleaners, primers, sealants and sealant removers.
- Undersized wiring systems can cause electrical fires.

Entanglement/Sever Hazard



Verify there are no people, obstacles or other equipment near the machine before starting the engine. Sound the horn as a warning before starting the engine.



If the engine must be serviced while it is operating, remove all jewelry and tie back long hair before operating or servicing the machine.

- Keep hands, other body parts, and clothing away from moving/rotating parts.
- Always stop the engine before beginning service. Before maintenance, remove negative battery cable from battery post to ensure vehicle is not operated during maintenance.
- Verify that all guards and covers are properly attached before starting the engine. Do not start the engine if any guards or covers are not properly installed on the paver.

Safety

- If you must run the engine during maintenance procedures, make sure you have a helper to keep bystanders clear of the paver and make observations of moving parts as requested by the operator.
- Always turn the start switch to the OFF position after operation is complete and remove the key from the switch. Keep the key in your possession when the paver is not operating.
- Attach a “Do Not Operate” tag near the key switch while performing maintenance on the equipment.
- Never operate the engine while wearing a headset to listen to a radio or music because it will be difficult to hear the warning signals.
- Always start the engine and operate the controls while seated in the operators seat.

Alcohol and Drug Hazard



Never operate the machine while under the influence of alcohol, drugs, or when ill.

Piercing Hazard



High-pressure hydraulic fluid or fuel can penetrate your skin and result in serious injury. Avoid skin contact with high-pressure hydraulic fluid or diesel fuel spray caused by a hydraulic or fuel system leak such as a broken hydraulic hose, fuel injection or high-pressure, common-rail engine line.

- If you are exposed to high-pressure hydraulic fluid or fuel spray, obtain prompt medical treatment.
- Never check for a hydraulic fluid or fuel leak with your hands. Always use a piece of wood or cardboard. Have your authorized LeeBoy dealer or distributor repair the damaged parts.

Flying Object Hazard



Always wear eye protection when cleaning the machine with compressed air or high-pressure water.

Dust, flying debris, compressed air, pressurized water or steam may cause eye injury.

Coolant Hazard



Coolant must be handled properly to ensure operator safety.

- Wear eye protection and rubber gloves when handling engine coolant.
- If contact with the eyes occurs, flush eyes with clean water for 15 minutes.
- If contact with skin occurs, wash immediately with soap and clean water.

Burn Hazard



Some of the machine's surfaces become very hot during operation and shortly after shutdown.

- Keep hands and other body parts away from hot machine surfaces.
- Handle hot components with heat-resistant gloves.

NOTICE

The safety messages that follow have NOTICE level hazards.

Any part that is found defective as a result of inspection or any part whose measured value does not satisfy the standard or limit must be replaced.

Always tighten components to the specified torque. Loose parts can cause damage to the machine or cause it to operate improperly.

Only use replacement parts approved by LeeBoy. Other replacement parts may affect warranty coverage.



Follow the guidelines of the EPA or other governmental agencies for the proper disposal of hazardous materials such as engine oil, diesel fuel, and engine coolant. Consult the local authorities or reclamation facility.

Dispose of hazardous materials in accordance with all applicable laws and regulations. Never dispose of hazardous materials by dumping them into a sewer, on the ground, or into groundwater or waterways.

Clean all accumulated dirt and debris away from the body of the paver and its components before you inspect the paver or perform preventive maintenance procedures or repairs. Operating a paver with accumulated dirt and debris will cause premature wear of paver components. Accumulated dirt and debris also hinders effective paver inspection.

Retrieve any tools or parts that may have dropped inside of the paver to avoid improper paver operation.

If any alert indicator illuminates during paver operation, stop the engine immediately. Determine the cause and repair the problem before continuing to operate the paver.

MACHINE PRECAUTIONS

Hot Material Precautions

- Wear protective gear for face, hands, feet, and body when operating the paver.
- Allow machine to cool before repairing or maintaining working components.
- If hot asphalt touches skin, flush area immediately with cold water. DO NOT apply ice to the affected area. DO NOT ATTEMPT TO REMOVE ASPHALT CEMENT with products containing solvents or ammonia. Natural separation will occur in about 48 to 72 hours. Get medical attention as soon as possible.
- DO NOT remove radiator cap, drain plugs, service grease fittings, or pressure taps while engine is hot. Add coolant to the radiator and perform other services only when the engine is stopped and fully cooled.

Hydraulic Systems Precautions

- Ensure all components are in good working condition. Replace any worn, cut, abraded, flattened or crimped hoses and metal lines.
- DO NOT attempt makeshift repairs using tape, clamps or cements. The hydraulic system operates under extremely high pressure and such repairs could cause serious injury.
- Wear proper hand and eye protection when checking for a high pressure leak. Use a piece of wood or cardboard as a back stop to isolate and identify leaks.

WARNING Hydraulic oil under pressure can cause serious personal injury. Check for oil leaks with a piece of cardboard. DO NOT expose hands to possible high-pressure oil. Turn off engine before attempting to tighten oil lines and fittings.

- Escaping pressurized hydraulic fluid has force sufficient to penetrate the skin, which could cause serious personal injury. Ensure all pressure is relieved before disconnecting line, hoses or valves.
- If injury from concentrated high pressure steam or hydraulic fluid occurs, seek medical attention immediately. Injuries resulting from hydraulic fluid penetrating the skin's surface can result in serious infections or toxic reactions.

1

Safety

Refueling Precautions

- DO NOT overfill the fuel tank as overflow creates a fire hazard when spilled on hot components.
- DO NOT smoke when refueling and never refuel when the engine is running. Fuel is highly flammable and should be handled with care. Death or serious injury can occur due to explosion and/or fire.
- DO NOT fill tank to capacity. Allow room for expansion to reduce the risk of fuel expanding and spilling from the tank.
- Tighten fuel cap securely. Should fuel cap be lost, replace it with an original manufacturer's approved cap. Pressurization of the tank may result from use of non-approved cap.
- Prevent fires by keeping the machine clean of accumulated debris, grease, and spilled fuel.
- Use ultra-low sulfur diesel fuel (ULSD) only.

Battery Precautions

- Keep all sparks and flames away from batteries, as gas given off by electrolytes is explosive.
- Acid propelled by an explosion can cause blindness if it comes in contact with eyes. Always wear safety glasses when working near batteries.
- If you come in contact with battery electrolyte solution, wash off immediately. Chemicals can cause burns.
- Always disconnect the battery ground cable before working on the electrical system to avoid injury from spark or short circuit. Electrical shock and burns can occur.
- To avoid electrolyte loss, DO NOT tip batteries more than 45 degrees.

Starting and Stopping Precautions

- Check all around the paver to make sure there are no people working on the machine or in the path of the machine before starting. DO NOT start until area is clear. Death or serious injury can occur to bystanders from being crushed under a moving machine.
- Check brakes, steering and other control devices in accordance with instructions before starting. Be sure both steering levers (joysticks) are in neutral with the neutral lock engaged.

- DO NOT bypass the paver neutral-start system.
- Be aware of job site conditions and terrain. Adjust your speed if operating in rough or hilly conditions.

 **WARNING DO NOT operate the engine in an enclosed area without proper ventilation. Exhaust gasses are odorless and deadly.**

Parking Precautions

- Park paver on level ground whenever possible, set steering levers in neutral and lock. Apply the parking brake. Park the paver with wheels securely blocked on grades.
- Remove ignition key when leaving paver parked or unattended.

Operating Precautions

- Always comply with local regulations regarding moving equipment on public roads and highways.
- Know and use the hand signals required for a particular job. Know who has the responsibility for signaling.
- Make sure that all lights and reflectors comply with state and local regulations. Make sure that they are clean, in good working order, and can be seen clearly by all traffic.
- DO NOT stand between the equipment and the truck while the truck is being backed to the paver. Death or serious injury can result from being crushed between the two machines.
- DO NOT ride on attachments.
- Check all gauges and warning instruments for proper operation. If malfunctions are found, shut down the machine and report the problem for resolution. If the failure causes loss of steering control, loss of brake control, or loss of engine power, stop paver motion as quickly as possible. Apply parking brake (if equipped). Keep the machine securely parked until the failure is corrected or the machine can be safely towed.
- Drive the machine with care. Make sure speed is compatible with conditions. Use caution on rough ground, slopes, and while turning.
- Be alert for hazards and obstructions such as ditches, trees, cliffs, overhead power lines, and areas where there is danger of a slide.

- Be aware of and understand the job site traffic flow patterns.
- Obey flagmen, road signs, and signals.
- Watch for bystanders. Never allow anyone near the machine during operation. Never allow anyone to reach into the machine during use.
- Operator must know how to use signaling devices when driving the machine. Operator must also understand which circumstances require use of each signal. Use tail lights, slow moving vehicle signs, and warning beacon as needed when traveling on public roads. It is recommended that you provide an escort on the road.
- DO NOT tow the paver, except to remove from road or to load on trailer.
- The machine is shipped with two seats, one for the left side operation and one for the right side operation. It is recommended that you operate the paver from the seats. If for any reason the seats are removed, care must be taken to operate from a position with stable footing and use of the grab handles provided.
- When moving the machine, adjust speed and direction of travel for the terrain and ground conditions present. Always consider adjusting travel speed to match ground conditions.

Poor Visibility

Increasingly, asphalt maintenance equipment is used during less than ideal lighting conditions such as fog and smog or at night. These conditions present safety hazards for workers, bystanders and passing traffic.

⚠️ WARNING When operating under restricted light conditions, equip the machine with special lighting to prevent serious injury.

While the machine is equipped with a beacon and a work light, contact your authorized LeeBoy dealer for additional lighting packages if working under these conditions.

Use reflective tape on the sides of machines when working at night. Ensure all workers wear reflective safety vests. Use impact barriers (movable or stationary) to protect workers and direct the traffic flow safely away from the work site.

Storage Precautions

- Store paver in an area away from human activity.
- DO NOT permit children to play on or around the stored machine. Serious injury or death can occur from improper/unauthorized use of the machine.
- Make sure the unit is stored on a surface that is firm, level, and free of debris.
- Store the machine inside a building or cover securely with a weatherproof tarpaulin.

Maintenance Precautions

- DO NOT attempt repairs unless trained to do so. Refer to manuals and experienced repair personnel for help.
- Before working on the machine, securely block the machine and any components that may fall. Block any working components to prevent unexpected movement while repairs are being made.
- Always wear safety glasses and other required safety equipment when servicing or making repairs.
- Disconnect battery before working on the electrical system.
- Avoid lubrication or mechanical adjustments while the paver is in motion or while engine is operating.
- If lubrication or mechanical adjustment is necessary, use extreme caution and complete the following steps:
 1. Place Forward/Reverse joystick in NEUTRAL (center position) on both control boxes. This engages the brake.
 2. Place the Run/Stop switch in the STOP position on both control boxes.
 3. Lower screed to ground or lock the screed in the upright position.
 4. Shut off engine.
- Never make repairs on pressurized components such as fluid lines, the low-pressure diesel fuel lines, or mechanical items until the pressure has been relieved.
- When servicing or replacing hardened pins, use a brass drift or other suitable material between the hammer and pin.
- Keep brake and steering systems in good operating condition.

Safety

SAFETY DECALS

If your machine is repainted, it is extremely important that you replace all the CAUTION, WARNING and DANGER safety decals in the proper locations. (Figure 1-1) For additional help, refer to the parts listing in Section 7 and contact your authorized LeeBoy dealer to order a replacement kit.

NOTE: It is the responsibility of the owner and operator to make sure that all safety labels are readable and located on the paver as designated by LeeBoy.

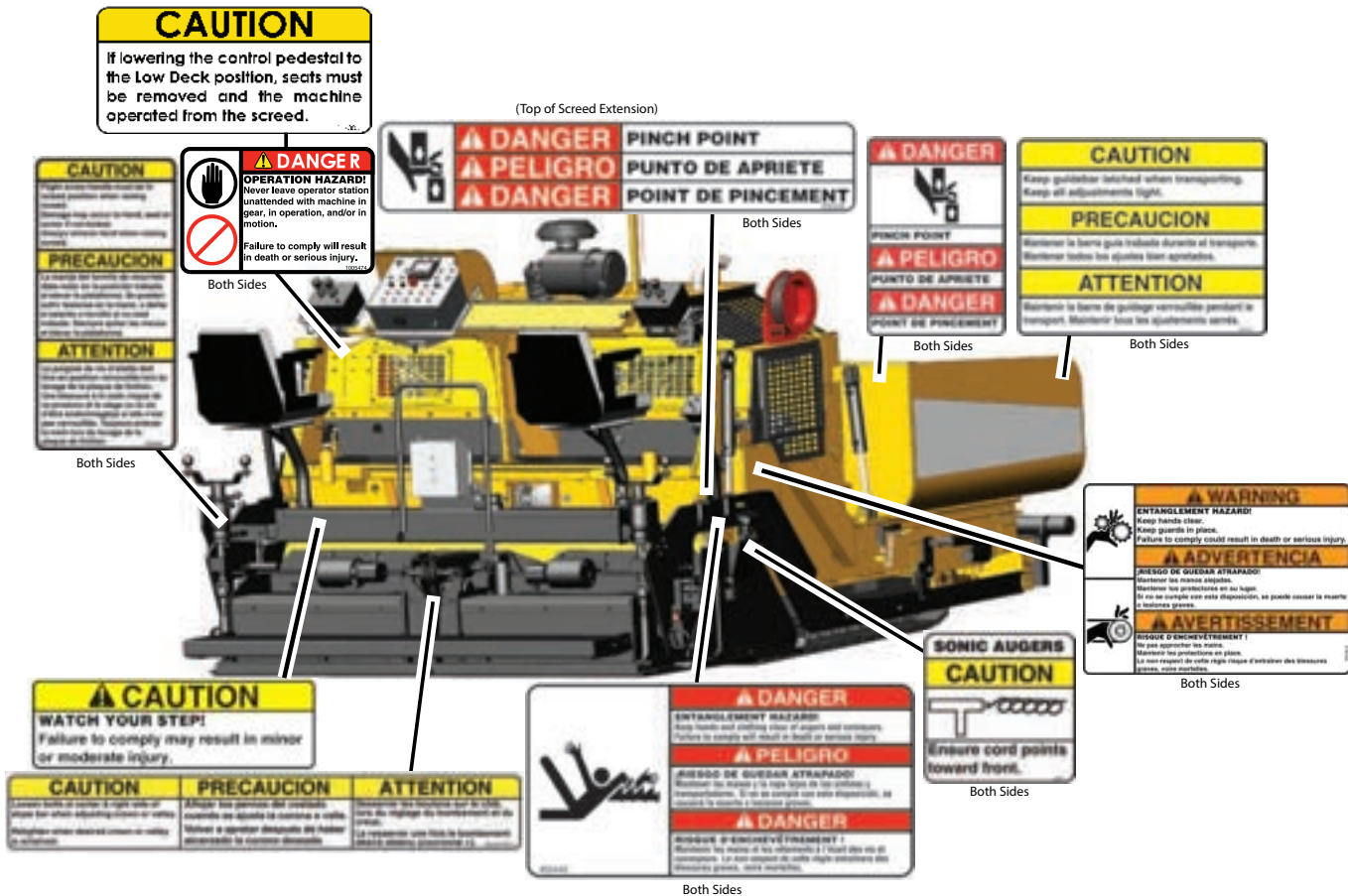

Figure 1-1. Safety Labels and Safety Label Locations

Safety Decals Care

1. Keep safety decals and signs clean and legible at all times.
2. Become familiar with the content and the position of each safety decal. Decals include important information.
3. Replace decals and signs that are missing or become impossible to read.
4. When replacing parts that display a safety decal, ensure that the new part is fitted with a decal as well.
5. Obtain replacement safety decals or signs from your authorized LeeBoy dealer.

Decal Installation (Sticker Type)

1. Be sure that the installation area is clean and dry. Use hot, soapy water to clean the surface where the decal will be applied.
2. Thoroughly dry the surface.
3. Measure and fit decal before removing the paper backing.
4. For decals with no top protection paper, remove the smallest split-backed paper.
5. Align decal over the specified area and carefully press exposed portion into place.
6. Slowly remove the remaining backing and carefully smooth the remaining portion of the decal into place.
7. Small air pockets can be pierced with a pin and smoothed using a piece of the decal backing.

Decal Installation (Top Protected)

1. If the decal has a protective top paper, use hot soapy water on the surface where the decal will be applied. Leave wet.
2. Determine the proper location, remove protective back paper and soak decal in clean soapy water before application. This will help to alleviate air bubbles in the applied decal.
3. Smooth decal into place with a squeegee and check for air bubbles.
4. Small air pockets can be pierced with a pin and smoothed out using a piece of the decal backing.
5. When decal is completely smoothed, carefully remove top paper.

NOTES

Section 2

INFORMATION AND SPECIFICATIONS



	Page
Limited Warranty Policy	2-2
Contact Information	2-3
Specifications Charts.	2-4
Torque Specifications	2-7
Standard Inch Fasteners.	2-7
Metric Fasteners.	2-8
Hydraulic Fittings	2-8
Determining Proper Torque	2-9

Information and Specifications

LIMITED WARRANTY POLICY

Warranty

Subject to the limitations, exclusions, and claims procedures set forth herein, VT LeeBoy, Inc. warrants (to the first retail purchaser) that this product will be free from substantial defects in materials and workmanship during the warranty period.

If a defect in material or workmanship is found, your authorized LeeBoy Dealer is to be notified during the warranty period. LeeBoy and its authorized Dealer will repair or replace any part or component of the unit or part that fails to conform to the warranty during the warranty period.

The warranty period will begin on the initial start-up, training and delivery of the unit by the Dealer to the customer, and will expire after twelve (12) months following the delivery of the product to the first retail purchaser. (See Dealer for additional warranty.)

Manufacturers' Warranties: Engines are warranted by their manufacturers and may have warranty coverage that differs from that of LeeBoy. LeeBoy does not warrant any engine.

Replacement parts furnished by LeeBoy are covered for the remainder of the warranty period applicable to the unit or component in which such parts are installed.

LeeBoy warrants for three thousand (3000) hours that the original wide-conveyor floor assembly will be free from manufacturer's defects and/or deterioration due to normal operation. This warranty is valid to the original purchaser on all LeeBoy wide-conveyor asphalt pavers. The eligible part for replacement is the wide-conveyor floor assembly.

LeeBoy has the right to repair any component or part before replacing it with a new one.

All new replacement parts purchased by a LeeBoy Dealer will carry a six-month warranty.

This Limited Warranty is governed by the laws of the State of North Carolina.

THE FOREGOING WARRANTY IS EXCLUSIVE AND IN LIEU OF ALL OTHER EXPRESSED, STATUTORY AND IMPLIED WARRANTIES APPLICABLE TO UNITS, ENGINES, OR PARTS INCLUDING WITHOUT LIMITATION, ALL IMPLIED WARRANTIES OF MERCHANTABILITY OR FITNESS FOR ANY PARTICULAR USE OR PURPOSE OR AGAINST INFRINGEMENT.

Items Not Covered

LeeBoy is not responsible for the following:

All used units or used parts of any kind.

Repairs due to normal wear and tear or brought about by abuse or lack of maintenance of the machine.

Attachments not manufactured or installed by LeeBoy.

Liability for incidental or consequential damages of any type including, but not limited to, lost profits or expenses of acquiring replacement equipment.

Limitations

VT LeeBoy, Inc. has no obligation for:

Any defects caused by misuse, misapplication, negligence, accident, or failure to maintain or use in accordance with the most current operating instructions.

Unauthorized alterations.

Defects or failures caused by any replacement parts or attachments not manufactured by or approved by LeeBoy.

Failure to conduct normal maintenance and operating service including, without limitation, providing lubricants, coolant, fuel, tune-ups, inspections, or adjustments.

Unreasonable delay, as established by LeeBoy, in making the applicable units or parts available upon notification of a service notice ordered by same.

Warranty Responsibility: The warranty responsibility on all engines rests with the manufacturer of the engine.

Warranty and Parts Support: LeeBoy may have support agreements with some engine manufacturers for warranty and parts support. However, LeeBoy does not warrant the engine.

This Limited Warranty sets forth your sole remedy in connection with the sale or use of the LeeBoy product covered by this Limited Warranty.

This Limited Warranty extends only to the first retail purchaser, and is not transferable.

In the event any portion of this Limited Warranty shall be determined to be invalid under any applicable law, such provision shall be deemed null and void and the remainder of the Limited Warranty shall continue in full force and effect.

Other Limitations

IN NO EVENT, WHETHER AS A RESULT OF BREACH OF CONTRACT OR WARRANTY OR ALLEGED NEGLIGENCE OR LIABILITY WITHOUT FAULT, SHALL LEEBOY BE LIABLE FOR SPECIAL, INCIDENTAL OR CONSEQUENTIAL DAMAGES INCLUDING, WITHOUT LIMITATION, LOSS OF PROFIT OR REVENUE, COST OF CAPITAL, COST OF SUBSTITUTED EQUIPMENT, FACILITIES OR SERVICES, DOWNTIME COSTS, LABOR COSTS OR CLAIMS OF CUSTOMERS, PURCHASERS OR LESSEES FOR SUCH DAMAGES. IN NO EVENT WILL WARRANTY COMPENSATION, OR OTHER DAMAGES AVAILABLE FROM LEEBOY EXCEED THE PURCHASE PRICE OF THE PRODUCT.

CONTACT INFORMATION

For information regarding parts and repairs about your LeeBoy product, contact your authorized LeeBoy dealer. If your dealer is unable to resolve the problem, contact LeeBoy directly.

Record dealer information in the space provided. For additional information about LeeBoy, please visit: www.leeboy.com.

Sales Representative: _____
Dealership Name: _____
Dealership Address: _____
Dealership Phone: _____

Record of Ownership

Please complete the following information for use if you need to contact LeeBoy for service, parts or literature.

Machine Model Number: _____
Product Serial Number: _____
Date of Purchase: _____

Nameplate

The nameplate contains the model and serial numbers used to identify the machine and its components for parts or service information. Refer to the Engine Operator's Manual for the location of the engine nameplate.

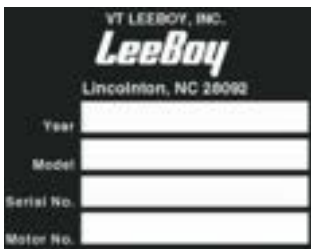

Figure 2-1. Nameplate Location

Information and Specifications

SPECIFICATION CHARTS

The specifications provided in this section include screed weights, dimensions, performance, and torque values for both metric and standard inch fastener.

CAUTION Replace original equipment only with components approved by your LeeBoy dealer.

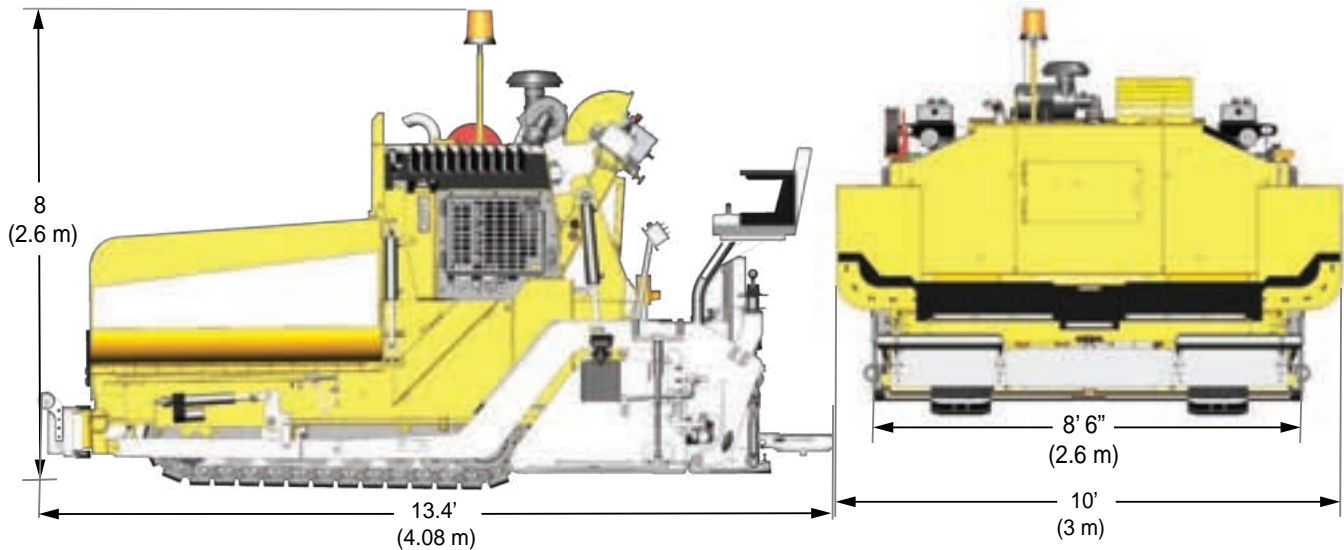

Table 2-1. Machine Dimensions

ITEM	SPECIFICATION
Overall Length	13 ft 4 in (4.08 m)
Overall Height	8 ft (2.6 m)
Overall Width (Hopper Wings In)	8 ft 6 in (2.6 m)
Overall Width (Hopper Wings Out)	10 ft (3 m)
Overall Weight	With Standard Screed: 17,600 lbs (7983.2 kg) With HD Screed: 17,940 lbs (8137.4 kg)
Paving Width	8 - 15 ft (2.4 - 4.6 m)
Tunnel Area	5.5 sq ft (.51m ²)

Table 2-2. Engine Specifications

ITEM	SPECIFICATION
Manufacturer and Model	Kubota, V3800-CR-TE4B (Tier 4 Final)
Engine Type	Vertical Liquid Cooled Diesel, 4-Cylinder
Bore, Stroke and Displacement	3.9 in (100 mm); 4.72 in (120 mm); 2.30 cu in (3.8 L)
Power Rating	74 HP (55.2 kW)
Intake and Combustion Systems	Turbo-Charged, Direct-Injection
Maximum Speed	2200 RPMs

Information and Specifications

Table 2-3. Performance Specifications

ITEM	SPECIFICATION
Travel Speed	0 - 230 feet per minute (FPM) [0 - 3.9 meters per minute (MPM)].
Paving Speed	0 - 140 FPM [0 - 2.4 MPM]
Recommended Paving RPMs	1800 RPMs
Maximum Paving Depth	6 in (152 mm)

Table 2-5. Electrical Specifications

ITEM	SPECIFICATION
Battery	12 Vdc Maintenance Free, 12 Volts
Cold Cranking Amps (CCA)	1000 CCA
Alternator	12-Volt, Negative-Ground, 60 Amps
Starter Voltage and Type	12-Volt, Negative-Ground

Table 2-6. Lubricant Specifications

ITEM	SPECIFICATION
Engine Oil	15W-40, API, CH-4, CI-4
Hydraulic Oil	All-Weather 32
Torque Hub	90 WT Gear Oil
Grease	Shell Avania EP Grease or Equivalent
Chain Lube	Chain Lube Agent

Table 2-7. Machine System Capacity Specifications

ITEM	SPECIFICATION
Engine Lubrication Oil (Refill Capacity)	15 qts (14.2 L)
Hydraulic Oil Tank	53 gal (151.4 L)
Torque Hubs	32 oz (.35 L) each
Diesel Fuel Tank	18.5 gal (70 L)
Spraydown Tank	7 gal (26 L)
Antifreeze	Glycol-Based, Extended Life; 3.6 gal (13.8 L)

Table 2-8. Hydraulic Pressures Specifications

ITEM	SPECIFICATION
Drive	3625 psi (249.9 Bar)
Conveyors	3400 psi (234 Bar)
Auger	3400 psi (234 Bar)
Track Tensioning Relief	1500 psi (103.4 Bar)
Charge Pressure	350 - 400 psi (24 - 27.6 Bar)

2

Information and Specifications

Table 2-9. Hopper Specifications

ITEM	SPECIFICATION
Material Capacity	7.5 Tons (6804 kg)
Height	23 in (584 mm)
Wings	3/8 in (10 mm)

Figure 2-10. Screed Specifications

ITEM	SPECIFICATION	
	Standard Screed	815HD (Option)
Screed Weight	3000 lbs (1360 kg)	3700 lbs (1678 kg)
Electric Heat (Option)	Two (2) 1750-watt electric heat elements on main screed. One (1) 1000-watt electric heat element on each screed extension.	Two (2) 2000-watt S-Curve electric heat elements on main screed. One (1) 1000-watt electric heat element on each screed extension.
Main Screed Width	8 ft (2.6 m)	
Screed Extensions	Two (2) 44-inch Hydraulically-Operated WIDTH: 3 ft 6 in (30 cm) each	
Extension Width of Wear Plate	7 in (17.8 cm)	
Bullnose Radius	1.37 in (34.9 cm)	
Vibration	Two (2) hydraulic vibrators producing 2400 vpm.	
Crown/Valley	Adjustable, 2-inch crown, 1-1/2 inch of valley	

Table 2-11. Generator Specifications

ITEM	SPECIFICATION
Power	10 kW
Voltage	240 Volts
Frequency	60 Hz

TORQUE SPECIFICATIONS

The following tables list torque values for standard hardware. This is a guide for average application involving typical stresses and machined surfaces. Values are based upon physical limitations of clean, plated and lubricated hardware. Under more extreme conditions, individual torque value should be followed. Conversion formulas are provided below:

NOTICE Never substitute fasteners of any kind that are not equal in size and grade to the original equipment.

Conversion	Formula
ft-lb to N•m	[ft-lb]*1.3558 = [N•m]
ft-lb to in-lb	[ft-lb]*12 = [in-lb]
N•m to in-lb	[N•m]*8.8508 = [in-lb]

Standard Inch Fasteners

Table 2-12. Torque Specifications For Standard Inch Fasteners

SIZE	THREAD	CAPSCREWS: SAE GRADE 5				CAPSCREWS: SAE GRADE 8			
		TORQUE (ft lb)		TORQUE N•m		TORQUE (ft lb)		TORQUE N•m	
		Dry	Lubed	Dry	Lubed	Dry	Lubed	Dry	Lubed
1/4	20 UNC	8	6	11	8	12	9	16	12
	28 UNF	10	7	14	9	14	10	19	14
5/16	18 UNC	17	13	23	18	25	18	34	24
	24 UNF	19	15	26	20	27	20	37	27
3/8	16 UNC	31	23	42	31	44	33	60	45
	24 UNF	35	26	47	35	49	37	66	50
7/16	14 UNC	49	37	66	50	70	52	95	71
	20 UNF	55	41	75	56	78	58	106	79
1/2	13 UNC	75	57	102	77	106	80	144	108
	20 UNF	85	64	115	87	120	90	163	122
9/16	12 UNC	109	82	148	111	154	115	209	156
	18 UNF	121	91	164	123	171	128	232	174
5/8	11 UNC	150	113	203	153	212	159	287	216
	18 UNF	170	127	230	172	240	180	325	244
3/4	10 UNC	267	200	362	271	376	282	510	382
	16 UNF	297	223	403	302	420	315	569	427
7/8	9 UNC	429	322	582	437	606	455	822	617
	14 UNF	474	355	643	481	669	502	907	681
1	8 UNC	644	483	873	655	909	681	1232	923
	14 UNF	722	542	979	735	1020	765	1383	1037
1-1/4	7 UNC	1121	840	1520	1139	1817	1363	2464	1848
	12 UNF	1241	930	1683	1261	2012	1509	2728	2046
1-1/2	6 UNC	1950	1462	2644	1982	3162	2371	4287	3215
	12 UNF	2194	1645	2975	2230	3557	2668	4823	3617

Information and Specifications

Metric Fasteners

Table 2-13. Torque Specifications for Metric Fasteners

NOMINAL SIZE AND PITCH	CLASS 8.8 [GRADE 5 EQUIVALENT]				CLASS 10.9 [GRADE 8 EQUIVALENT]			
	TORQUE (ft lb)		TORQUE N•m		TORQUE (ft lb)		TORQUE N•m	
	Dry	Lubed	Dry	Lubed	Dry	Lubed	Dry	Lubed
M4 x 0.7	2	2	3	2	3	2	4	3
M5 x 0.8	5	3	7	4	7	5	9	7
M6 x 1	8	6	11	8	11	8	15	11
M8 x 1.25	19	14	26	19	27	20	37	27
M10 x 1.5	37	28	50	38	53	40	72	54
M12 x 1.75	65	49	88	66	93	70	126	95
M14 x 2	104	78	141	106	148	111	201	150
M16 x 2	161	121	218	164	230	173	312	235
M18 x 2.5	222	167	301	226	318	239	431	324
M20 x 2.5	314	236	426	320	449	337	609	457
M22 x 2.5	428	321	580	435	613	460	831	624
M24 x 3	543	407	736	552	777	582	1053	789
M27 x 3	796	597	1079	809	1139	854	1544	1158
M30 x 3.5	1079	809	1463	1097	1544	1158	2093	1570

Hydraulic Fittings

Tightening Flare-Type Tube Fittings

1. Check the flare and flare seat for defects that might cause leakage.
2. Align tube with fitting before tightening.
3. Lubricate connection.
4. Hand tighten swivel nut until snug.
5. To prevent twisting the tube(s), use two wrenches. Place one wrench on the connector body and tighten the swivel nut with the second to the torque shown in the following table:

NOTE: The torque values shown are based upon lubricated connections.

Table 2-14. Torque Specifications for Steel Flare Type Tube Fittings

TUBE SIZE OUTER DIAMETER	NUT SIZE ACROSS FLATS	TORQUE VALUE	
		(LB FT)	(N•m)
3/16	7/16	8	11
1/4	9/16	12	16
5/16	5/8	16	22
3/8	11/16	23	31
1/2	7/8	38	52
5/8	1	54	73
3/4	1 1/4	75	102
7/8	1 3/8	83	113

Determining Proper Torque

The only reliable method of creating a consistently leak-free and long-lasting connection is to ensure the coupling is brought to the proper torque. Using a torque wrench with crowfoot is the best method, but the flats method can be used if a torque wrench is not available.

The most straightforward method of determining the correct torque setting is to multiply the desired torque by the length of the wrench from the center of the handle to the center of the drive (L); divided by the length of the wrench from the center of the handle to the crowfoot center (LA) as shown below:

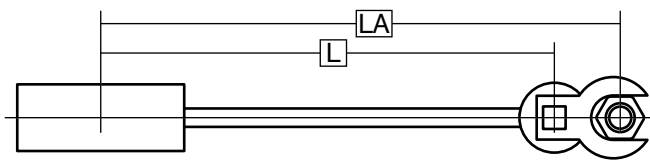

Figure 2-15. Torque Wrench - Crowfoot

NOTICE

The minimum torque values are adequate for sealing most applications. Maximum torque values should never be exceeded.

There are several methods of determining the correct setting on the torque wrench when using a crowfoot. All of the methods involve making the setting proportional to the effective change in length of the wrench multiplied by the desired final torque. The equations and illustration below describe proper measurements.

Equations

- Torque setting if the crowfoot is placed in line with respect to the wrench:

$$TS = TD * L / LA$$

OR

$$TS = TD * L / (L+E)$$

- Torque setting if the crowfoot is placed at 90° with respect to the wrench

$$TS = TD * L / LH$$

OR

$$TS = TD * L / \sqrt{(L^2 + E^2)}$$

- To estimate the crowfoot size (E)

$$E = \text{Drive Size} * 0.5 + \text{Distance between Drive and Open End} + \text{Wrench Size} * 0.5774$$

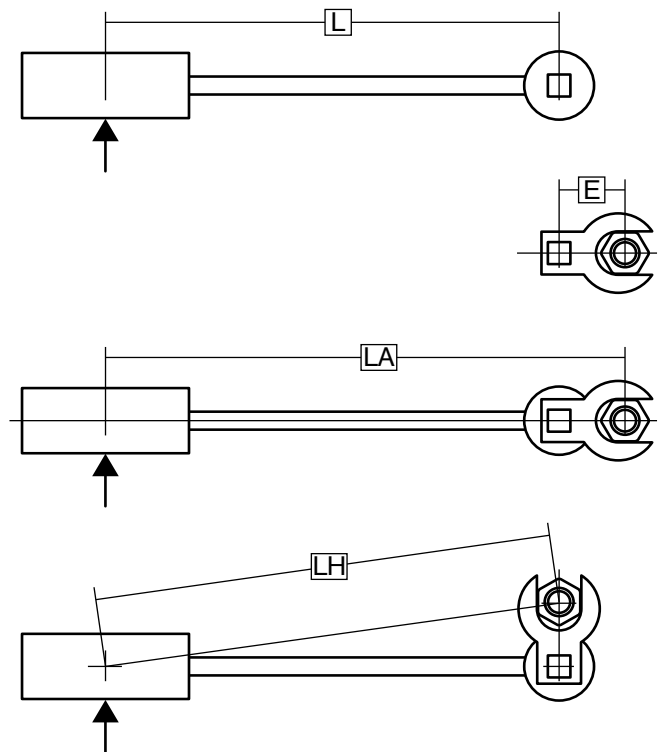

Figure 2-16. Measurements Needed

LEGEND

L = Distance from center of torque wrench handle to the center of socket drive

E = Distance from center of socket drive to the center of crowfoot

LA = Distance from center of torque wrench handle to the center of crowfoot

LH = Distance from center of torque wrench handle to the center of crowfoot, when mounted at 90°

TD = Desired torque at the fitting

TS = Torque setting indicated on wrench

2

Information and Specifications

Coupling Installation

Use the following steps for proper coupling installation:

1. Determine the correct torque value for your coupling.

NOTE: Only use the torque values specified from the manufacturer. DO NOT use SAE torque recommendations.

2. Ensure the seal face and threads are clean and in good condition. O-Rings should be lubricated with light oil, but threads should be completely dry unless making pipe thread connections (interference seal).

NOTE: Attach the male end of the hose onto the equipment first since it may be necessary to rotate the entire hose assembly to tighten the male threads. Then route the hose into position while avoiding twisting the hose.

3. Tighten the connection (by hand), bringing the seal face into contact and rotating the nut until it stops.
4. Mark a line across the coupling nut and backup hex for the flats method verification of coupling torque.
5. Apply a wrench to the backup hex to prevent the coupling and hose from moving while tightening the nut with a torque wrench.

NOTICE Failure to retain the backup hex during installation will also result in additional clamp load force that could cause damage to the seal face.

NOTE: The coupling nut must be in motion for an accurate torque reading. If the nut is stopped before final torque value is achieved, it must be loosened and retightened until the torque is attained while the nut is in motion.

If a torque wrench cannot fit into the coupling area or if it is unavailable, the flats method may be used to ensure that the coupling is properly tightened, as shown in the following figure.

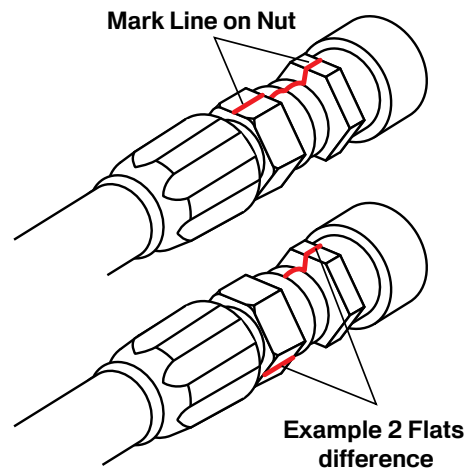

Figure 2-17. Flats Method Tightening

NOTE: The mark placed on the nut and backup hex after tightening by hand should rotate during final tightening according to the table below. The nut and backup hex can then be marked to indicate if the coupling loosens over time.

Table 2-18. Flats Method Values for Selected Terminations

FLATS METHOD VALUES		
Termination Type	Dash Size	Flats
JIC	-4	1.5 - 1.75
JIC	-6	1.0 - 1.5
JIC	-8	1.5 - 1.75
JIC	-10	1.0 - 1.5
JIC	-12	1.0 - 1.5
JIC	-16	.75 - 1.0
JIC	-20	.75 - 1.0
JIC	-24	.75 - 1.0
JIC	-32	.75 - 1.0
JIS	-4	.5 - 1.5

1. Seal faces must be in contact with the fitting fully tightened by hand before marking flats.
2. The flats method is most accurate for the first assembly cycle. For multiple disassembly and assembly cycles, torque values are more reliable.
3. Tightening two (2) flats or more may damage seal faces.

Information and Specifications

Table 2-19. Torque Specifications For US Style Coupling Terminations

JIC, SAE 45°, ORFS, O-RING BOSS, GATES ADAPTERLESS AND MEGASEAL										
DASH SIZE	JIC 37°, SAE 45° & Mega-Seal (Steel)		JIC 37°, SAE 45° & Mega-Seal (Brass)		Flat Face O-Ring Seal (Steel)		SAE O-Ring Boss (Steel) & Gates Adapterless ≤ 4000 PSI		SAE O-Ring Boss (Steel) & Gates Adapterless > 4000 PSI	
	Min	Max	Min	Max	Min	Max	Min	Max	Min	Max
-3									8	10
-4	10	11	5	6	10	12	14	16	14	16
-5	13	15	7	9					18	20
-6	17	19	12	15	18	20	24	26	24	26
-8	34	38	20	24	32	40	37	44	50	60
-10	50	56	34	40	46	56	50	60	72	80
-12	70	78	53	60	65	80	75	83	125	135
-14					65	80			160	180
-16	94	104	74	82	92	105	111	125	200	220
-20	124	138	75	83	125	140	133	152	210	280
-24	156	173	79	87	150	180	156	184	270	360
-32	219	243	158	175						

2

Table 2-20. Torque Specifications for DIN 24, DIN 60, and Inverted Cone Style Coupling Terminations

DIN 24, DIN 60, AND INVERTED CONE			
Size (mm)		Torque (lb ft)	
Light Series Tube OD	Heavy Series Tube OD	Min	Max
6		7	15
8		15	26
10	8	18	30
12	10	22	33
14	12	26	37
15	14	30	52
	16	30	52
18	20	44	74
22	25	59	89
28	30	74	111
	38	74	162
35		133	184
42		148	221

Table 2-21. Torque Specifications for 4-Bolt Flange Connections

4-BOLT FLANGES		
Dash Size	Bolt Size (in)	Torque (lb ft)
-8	0.31	17
-12	0.38	26
-16	0.44	43
-20	0.50	65
-24	0.63	130
-32	0.75	220

- Align faces and tighten bolts (by hand) before applying final torque in a pattern. The seal faces must be parallel with an even bolt tension to seal properly.
- Torque values apply to bolts that are plated or coated in light engine oil.
- Before assembly, lubricate O-Ring with light oil (SAE 10W or 20W).

Information and Specifications

Table 2-22. Torque Specifications for NPTF Dry Seal Pipe Threads

NPTF	
Dash Size	Max Torque (ft-lb)
-2	20
-4	25
-6	35
-8	45
-12	55
-16	65
-20	80
-24	95
-32	120

1. The torque values obtained from tightening pipe threads can vary considerably depending upon thread condition. Adequate sealing can occur at values much lower than the maximum values listed above. Only enough torque to achieve adequate sealing should be used.
2. When using a male tapered pipe thread with a female straight or parallel pipe thread, maximum values are 50% of those listed in the table above.
3. If thread sealant is used, maximum values shown should be decreased by 25%.

Table 2-23. Torque Specifications for BSP 30° Inverted Cone and JIS Coupling Terminations

BSP 30° INVERTED CONE AND JIS		
Dash Size	Torque (ft-lb)	
	Min	Max
-2	7	9
-4	11	18
-6	19	28
-8	30	36
-10	37	44
-12	50	60
-16	79	95
-20	127	152
-24	167	190
-32	262	314



Section 3

COMPONENT LOCATION

	Page
Component Location	3-1
Components Overview	3-3
Dual Operator Platforms	3-3
Augers	3-4
Hopper and Conveyors	3-4
Screed	3-4
Hydraulic System	3-4
Electrical System	3-4
Machine Overview	3-5
Control Panel (4-Function Screed Box)	3-6
Control Panel (9-Function Screed Box)	3-8
Steering and Speed Control Box	3-10
Electric Heat Controls	3-10
Screed Controls	3-11
9-Function Remote Screed Controls	3-12
4-Function Remote Screed Controls	3-13

NOTES

COMPONENTS OVERVIEW

This section describes the major components for the LeeBoy 8515E Conveyor Paver. Become familiar with these components before operating the machine.



Dual Operator Platforms

The dual operator platforms allow easy and convenient access for controls of most paver functions. The paver can be operated from the left or right side, depending upon which control panel side is active and best suited to the working conditions. Controls can also be lowered to operate as a low deck or the high deck option with an assistant standing on the screed walkboard.



Engine

The LeeBoy Model 8515E Conveyor Paver is equipped with a Kubota V3800-TIE4F, 74 HP (55.2 kW) diesel engine--a strong performer with the latest technology. The engine is accessible through several access doors, with a front service door where fuel filter components are located for easier access.

This electronically-controlled engine offers the latest in innovative emission solutions that comply with stringent regulations (EPA/CARB Tier 4 and EU Stage IIIB) for exhaust after-treatment that optimizes combustion. This Tier 4 Final fuel-efficient engine complies with emission requirements established by the U.S. Environmental Protection Agency (EPA) to reduce diesel particulate matter (DPM) and other toxins released into the air.

Advanced emission-control devices and low-sulfur fuel requirements--only Ultra-Low Sulfur Diesel (ULSD) can be used in these engines--combine with after-treatment methods such as Exhaust Gas Recirculation (EGR) and Diesel Particulate Filters (DPF).

The air cleaner removes fine particles such as dust, sand, chaff and lint from the air. As air is taken into the air cleaner assembly, the cyclone action deposits some of the fine particles in the evacuator that is mounted on the bottom of the air cleaner housing. The fuel filter removes contaminants from diesel fuel before it flows into the injection pump where it is injected into the engine combustion chamber.

The radiator mounted in front of the engine cools the engine. As coolant flows through the radiator, airflow from the engine-driven fan removes heat.

Refer to the Engine Operator's Manual accompanying your paver for additional engine information.

Track System

The paver drive system contains two heavy-duty torque hubs that propel the hydrostatically-powered, self-cleaning tracks with self-adjusting front idlers. Two-speed motors power tough planetary drives for smooth operation.

Component Location

Augers

Right and left augers rotate to move material from the conveyors to the screed. The auger can be manually controlled at the operator platform or by a screed operator on the screed using a remote screed control box.



The auger can also be controlled automatically using the auger sonic sensor system. The sensor is mounted on the screed endgates and used to monitor and control the pile height of material at the discharge end of the augers.

Hopper and Conveyors

Hydraulic power raises and lowers the hopper wings. The hopper wings can also be locked into place in the closed position for transport. When fully open, the hopper can hold a payload up to 7.5 tons.

Material in the hopper is moved toward the back of the paver to the screed by conveyors. Its wide, automatic conveyors with a wide hopper design delivers asphalt more evenly and efficiently to produce a smooth asphalt mat.

The conveyor bed can be lifted hydraulically, allowing easy access to the paver undercarriage and tracks for service and cleaning.



Screed

The screed is the last component that contacts the paving material. Asphalt material is fed from the hopper conveyor through the augers to the screed, where it is heated, applied and compacted onto the paving surface.

The LeeBoy 8515E Conveyor Paver is equipped with the Legend® screed system that is electrically heated. The optional Heavy Duty HD815 screed is also available. The main screed has hydraulically-controlled extensions on each side that extend and retract to allow paving widths from 8 - 15 feet. Hydraulically-driven dual vibrators mounted on the main screed frame increase paving material compaction. The screed can be locked in the raised position for travel, service and overnight parking for additional stability.

The optional HD815 screed features heavy-duty flight screws, heavy-duty crown and valley mechanism and 3-Adjuster AOA (Angle of Attack) with vertical height adjustment for even more screed control.

Hydraulic System

The hydraulic system consists of a tandem drive pump, a tandem conveyor and charge pump, and a tandem generator auger pump, along with hydraulic motors and cylinders that work together for optimum machine component control. Valves regulate the directional, pressure and fluid flow throughout the hydraulic system. A centralized hydraulic test port adds ease and convenience for checking and troubleshooting hydraulic pressure of its five main functions.

Electrical System

The battery produces 12 volts DC and maintains 1,125 cold cranking amperes (CCA). An engine-mounted alternator with a minimum of 60 amperes charging capacity keeps the battery charged during normal operation.

Heating controls provide the necessary connection and control of the output power from the generator to the heating elements. Each element is sized to fit properly in your screed, and provide sufficient power to heat your screed plate to a temperature so asphalt material will not drag or stick to the lower surface of the screed plate. The heating control is mounted near the middle of the main screed and is easily accessible to the screed operator when a heating cycle is required.

MACHINE OVERVIEW

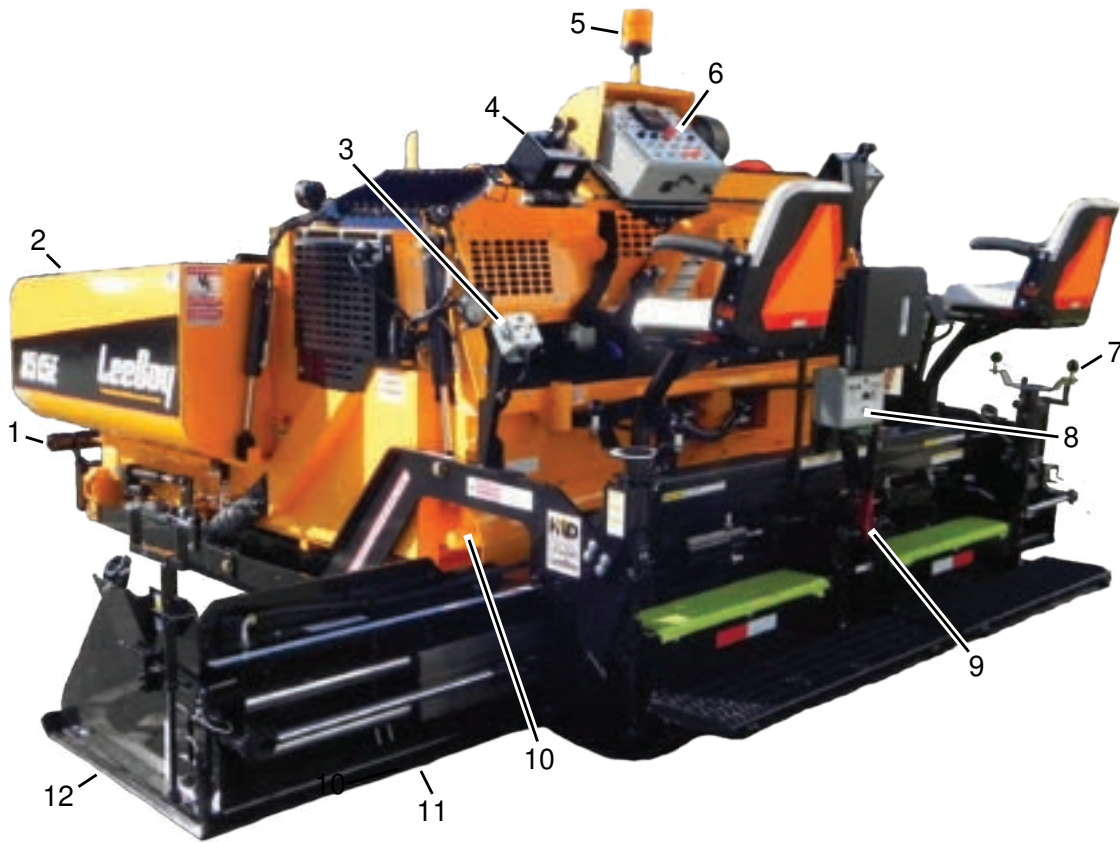

Figure 3-1. Machine Overview

ITEM NO.	CONTROL NAME	FUNCTION
1	Adjustable Roller Bar	Adjust height (manually) for roll-up to asphalt material truck.
2	Hopper	Hopper wings fold out to hold asphalt material.
3	Remote Screed Controls	Control box mounted on each side of screed with auger, screed extension, slope and cut-off controls.
4	Joysticks	Controls travel direction and speed (on each side of machine).
5	Beacon Light	Revolving amber safety light to alert traffic and others at the work site.
6	Operator Control Panel	Main operator control panel. Slides to either side of operator platform.
7	Main Screed Depth Screw	Controls depth of the asphalt (located on each side).
8	Electric Screed Heat Box	Controls for heating the screed.
9	Crown and Valley	Adjusts crown and valley while paving.
10	Auger	Rotates to move material from the conveyors to the screed.
11	Screed Extension	Extends paving width from 8 to 15 feet.
12	Endgate	Adjusts for a paving width to match joints and leave a clean edge.

CONTROL PANEL (4-FUNCTION SCREED BOX)

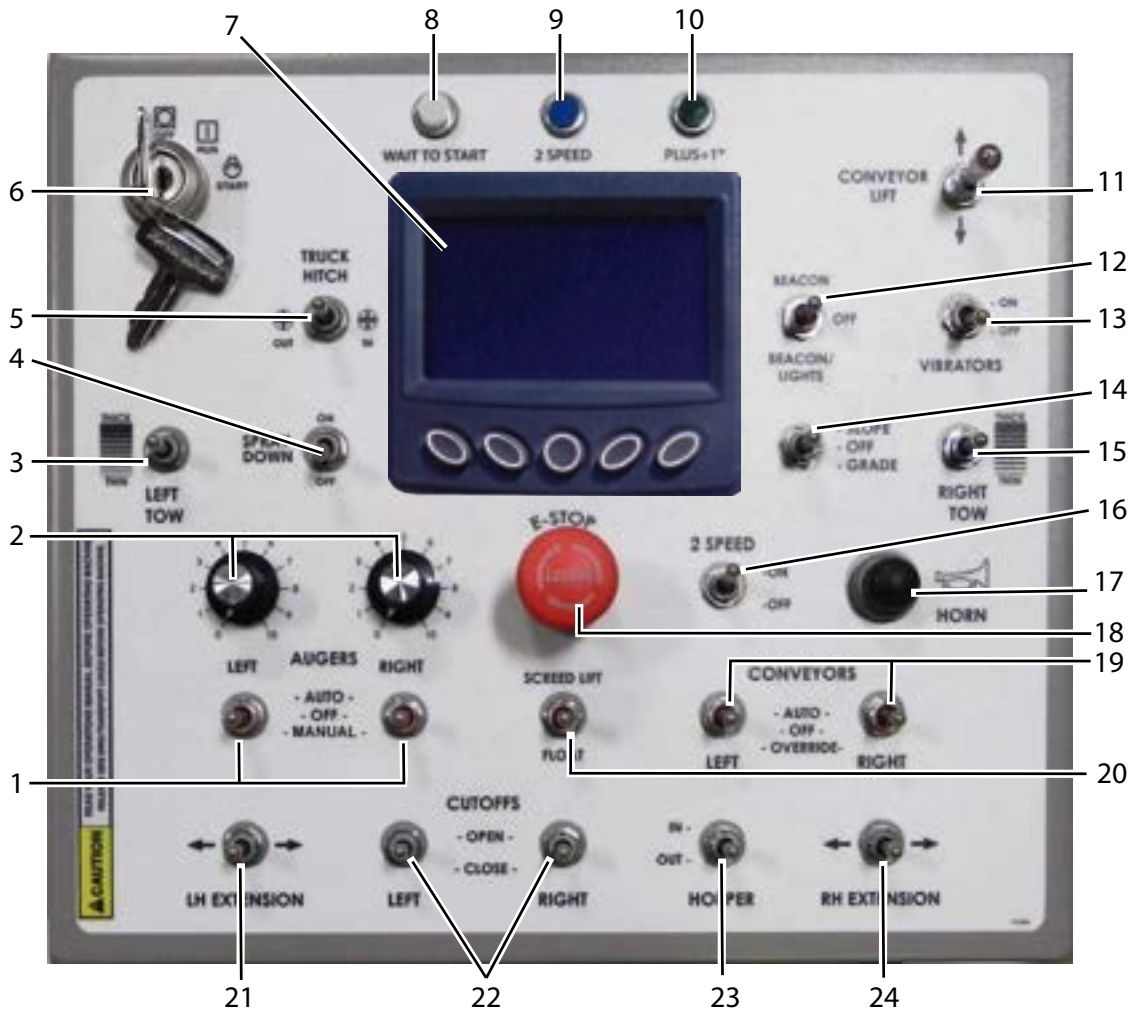

Figure 3-2. Operator Control Panel

ITEM NO.	CONTROL NAME	FUNCTION
1	Left and Right Auger Switches	Selects ON or OFF for automatic operation of right and left augers. Center position is OFF. Selecting the MANUAL position allows the augers to run continuously. NOTE: The auger switches must be set to the ON position (automatic mode) on the main control panel AND both remote screed control boxes when using the sonic auger sensor.
2	Right and Left Auger Dials	Controls left and right auger speeds. Turning clockwise increases auger speed while turning counterclockwise reduces auger speed. The auger switch(es) must be turned on for the auger dials to function. Adjust dial to desired auger speed.
3	Left Tow Thicker/ Thinner Switch	Sets the thickness of the asphalt. Operator can select either THICKER or THINNER as needed. The Grade Control switch must be set to GRADE on the control panel to turn power on for this feature.
4	Spraydown Switch	Turns on the spraydown system for spraying release agent to lubricate and prevent asphalt from hardening on machine surfaces.

ITEM NO.	CONTROL NAME	FUNCTION
5	Truck Hitch (Option)	Optional Component: Engages truck hitch function. Engages the truck hitch to the material truck wheels. Set switch to the IN position to engage the hitch. The OUT position disengages hitch from the material truck wheels.
6	Ignition	Starts and stops engine.
7	PV480 Digital Display	Displays paver setup and calibration information, engine operating information, and engine and paver system fault information.
8	Wait to Start Light	Illuminates for a few seconds during start-up. Starter will not engage until this light turns off.
9	2-Speed Light	Illuminates when paver is in high gear.
10	Plus One Light	The Plus One status light illuminates and blinks to alert the operator of a fault in the Plus One controller that monitors paver control systems.
11	Conveyor Lift	Controls raising and lowering conveyor bed.
12	Beacon/Work Lights	Used to alert surrounding vehicles and pedestrians. The beacon light also comes on when the work lights are turned on.
13	Vibrators Switch	Turns the screed vibrators on and off, but only functions when joysticks are in the forward position. The screed vibrator helps compact material.
14	Grade Control Switch	When this switch is in the GRADE position, the tow point switches are enabled regardless of the Run/Start switch position. When in the SLOPE position, the tow point switches are controlled by the automated system when joysticks are in the FORWARD position.
15	Right Tow Thicker/ Thinner Switch	Sets the thickness of the asphalt. Operator can select either THICKER or THINNER as needed. The Grade Control switch must be set to GRADE on the control panel to turn power on for this feature.
16	High/Low 2-Speed Gear Switch	Used to change machine speed. Place switch in HIGH position for travel (High/Low Gear light will illuminate). Pave only in LOW speed. NEVER pave in high speed.
17	Horn	Pressing this button sounds the horn.
18	E-Stop Button	Immediately stops the paver engine and all electronic functions. Turn clockwise to release E-Stop button.
19	Left and Right Conveyor Switches	Selects automatic or manual mode for left and right conveyors. For automatic operation, set switch to AUTOMATIC. MANUAL OVERRIDE position provides momentary manual override. The center position is OFF.
20	Screed Lift/Float Switch	Raises or floats the screed. When released, switch automatically returns to the center to hold the screed in selected position. Flip switch to RAISE to raise the screed. Set the switch to FLOAT to float the screed (switch will lock in the FLOAT position).
21	Left Extension Switch	Extends or retracts left screed extension. (Switch also located on the remote box on left side of paver.) Push switch IN to retract left screed extension. Push switch to OUT to extend left screed extension.
22	Left and Right Cut-Off Switches	Opens and closes left and right Under Auger Material Cut-Offs.
23	Hopper Switch	Opens and closes hopper side wings. Push switch to the OUT position to open hopper wings. Push switch to the IN position to close hopper wings.
24	Right Extension Switch	Extends or retracts right screed extension. (Switch also located on the remote control box. Push switch IN to retract right screed extension. Push switch to OUT to extend right screed extension.

CONTROL PANEL (9-FUNCTION SCREED BOX)

The main control panel is slightly different if equipped with the 9-Function Remote Screed Control box (Page 3-12) as shown below:

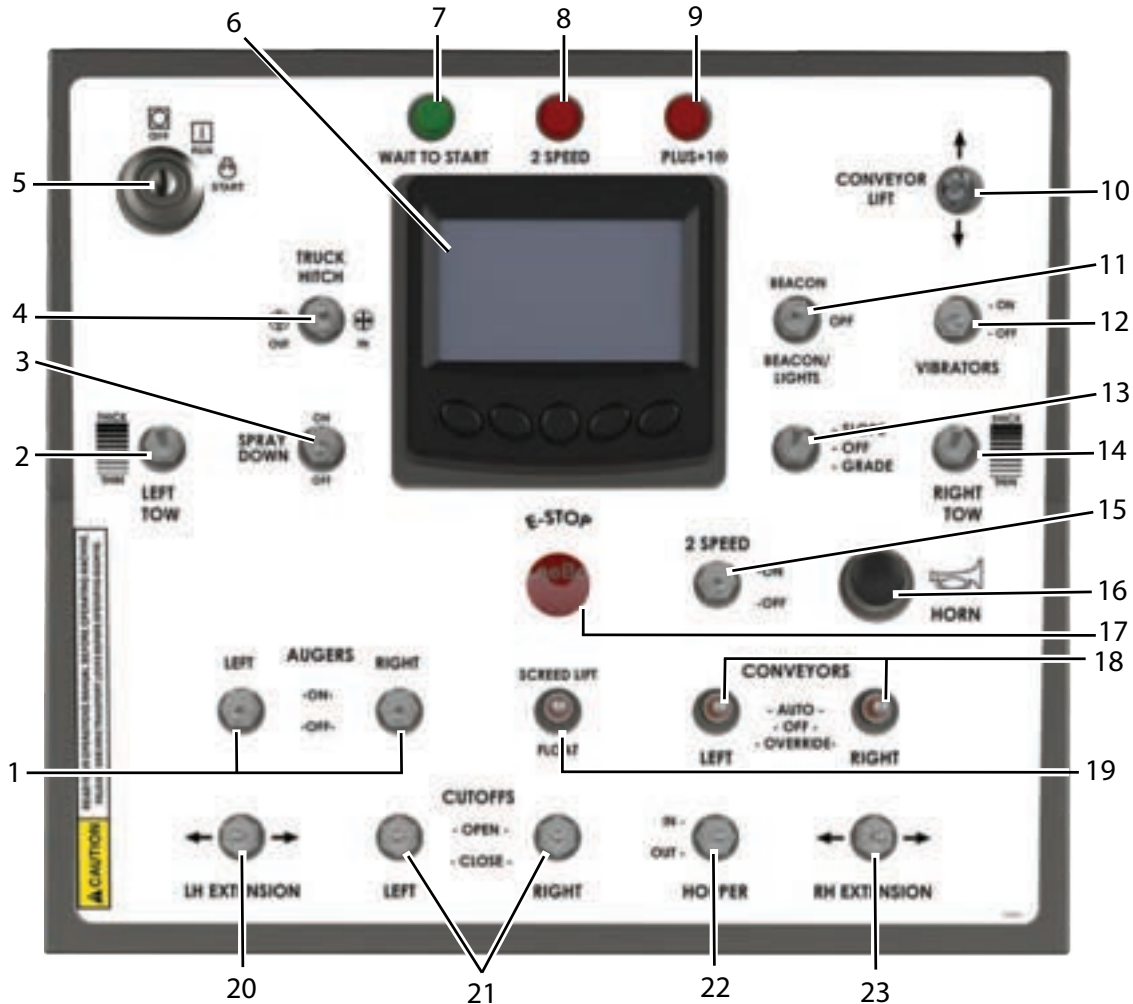

Figure 3-6. Operator Control Panel

ITEM NO.	CONTROL NAME	FUNCTION
1	Left and Right Auger Switches	Turns the left and right augers ON and OFF. Center position is OFF. Use the auger speed dials on the left or right 9-Function Remote Screed Control box to increase or decrease auger speed. NOTE: The auger switch on the 9-Function control box must be set to the AUTO position (automatic mode) if using the sonic auger sensor. (Page 4-24)
2	Left Tow Thicker/Thinner Switch	Sets the thickness of the asphalt and controls the electric flight screws. Operator can select either THICKER or THINNER as needed. The Grade Control switch must be set to GRADE on the control panel to turn power on for this feature.
3	Spraydown Switch	Turns on the spraydown system for spraying release agent to lubricate and prevent asphalt from hardening on machine surfaces.

ITEM NO.	CONTROL NAME	FUNCTION
4	Truck Hitch (Option)	Optional Component: Engages truck hitch function. Engages the truck hitch to the material truck wheels. Set switch to the IN position to engage the hitch. The OUT position disengages hitch from the material truck wheels.
5	Ignition	Starts and stops engine.
6	PV480 Digital Display	Displays paver setup and calibration information, engine operating information, and engine and paver system fault information.
7	Wait to Start Light	Illuminates for a few seconds during start-up. Starter will not engage until this light turns off.
8	2-Speed Light	Illuminates when paver is in high gear.
9	Plus One Light	The Plus One status light illuminates and blinks to alert the operator of a fault in the Plus One controller that monitors paver control systems.
10	Conveyor Lift	Controls raising and lowering conveyor bed.
11	Beacon and Work Lights	Used to alert surrounding vehicles and pedestrians. The beacon light also comes on when the work lights are turned on.
12	Vibrators Switch	Turns the screed vibrators on and off, but only functions when joysticks are in the forward position. The screed vibrator helps compact material.
13	Grade Control Switch	When this switch is in the GRADE position, the tow point switches are enabled regardless of the Run/Start switch position. When in the SLOPE position, the tow point switches are controlled by the automated system when joysticks are in the FORWARD position.
14	Right Tow Thicker/Thinner Switch	Sets the thickness of the asphalt and controls the electric flight screws. Operator can select either THICKER or THINNER as needed. The Grade Control switch must be set to GRADE on the control panel to turn power on for this feature.
15	High/Low 2-Speed Gear Switch	Used to change machine speed. Place switch in HIGH position for travel (High/Low Gear light will illuminate). Pave only in LOW speed. NEVER pave in high speed.
16	Horn	Pressing this button sounds the horn.
17	E-Stop Button	Immediately stops the paver engine and all electronic functions. Turn clockwise to release E-Stop button.
18	Left and Right Conveyor Switches	Selects automatic or manual mode for left and right conveyors. MANUAL position provides override. The center position is OFF. For automatic operation, set switch to AUTOMATIC.
19	Screed Lift/Float Switch	Raises or floats the screed. When released, switch automatically returns to the center to hold the screed in selected position. Flip switch to RAISE to raise the screed. Set the switch to FLOAT to float the screed (switch will lock in the FLOAT position).
20	Left Extension Switch	Extends or retracts left screed extension. (Switch also located on the remote box on left side of paver.) Push switch IN to retract left screed extension. Push switch to OUT to extend left screed extension.
21	Left and Right Under Auger Material Cut-Off Switches	Opens and closes left and right Under Auger Material Cut-Offs.
22	Hopper Switch	Opens and closes hopper side wings. Push switch to the OUT position to open hopper wings. Push switch to the IN position to close hopper wings.
23	Right Extension Switch	Extends or retracts right screed extension. (Switch also located on the remote control box. Push switch IN to retract right screed extension. Push switch to OUT to extend right screed extension.

STEERING AND SPEED CONTROL BOX



Figure 3-3. Steering and Speed Control Box

ITEM NO.	CONTROL NAME	FUNCTION
1	Left and Right Steering Joysticks	Joystick control speed and direction forward or reverse. The farther pushed in either direction, the faster the speed. Pull up on the locking collar to move joysticks forward or reverse.
2	Joystick Neutral Lock Collar	Locks the Forward/Reverse joystick in neutral. Lift up on the locking collar to move joysticks forward or reverse.
3	Run/Stop Switch	Controls stopping and activating/deactivating operator control station. When set to STOP, control station is deactivated, parking brake applied, and machine will not move. When set to RUN, control station is activated, parking brake is released, and machine resumes previously set speed.

ELECTRIC HEAT CONTROLS

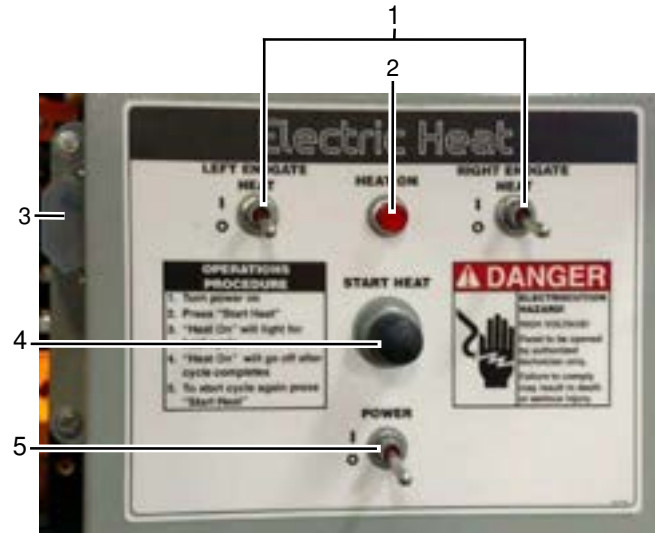

Figure 3-4. Electric Heat Controls

ITEM NO.	CONTROL NAME	FUNCTION
1	Left and Right Endgate Switches	OPTION: These switches do not function if not equipped with Heated Endgate Option. (Page 4-34)
2	Heat On Light	Illuminates and stays on as long as the element is heating the screed plates (approximately 20 minutes).
3	Start Heat Button	After turning on the power, press the Start Heat button. Once the heating function has been enabled, the distribution/control box will apply electrical power to the heating elements and the heating cycle will begin. The heating cycle is timed to optimize the heat generated at the screed plates. Press the button again to reheat the screed if needed.
4	Power Switch	Turns the electric heat system on and off.

SCREED CONTROLS



Figure 3-5. Screed Operation Controls

ITEM NO.	CONTROL NAME	FUNCTION
1	Flight Screw	Controls the depth of the asphalt.
2	Screed Extension Angle of Attack Screw	Adjusts the front of the extension wearplate to provide the best mat. Moves up or down and can level extension at wide widths.
3	Sonic Auger Sensor Mount	Screed extension mount for the sonic auger that senses and automatically gauges the amount of material in the extensions.
4	Depth Screw	Controls the depth of the endgate.
5	Tilt Screw	Adjusts the tilt of the endgate.
6	Crown and Valley Adjuster	Adjusts for positive crown or negative valley in wear plate. NOTE: Power Crown option available.
7	Electric Heat Box	Control box for the electric screed heat.

Component Location

9-FUNCTION REMOTE SCREED CONTROLS

The 9-function remote screed extension control boxes are mounted on each side of the paver for screed operator convenience (left control box shown).

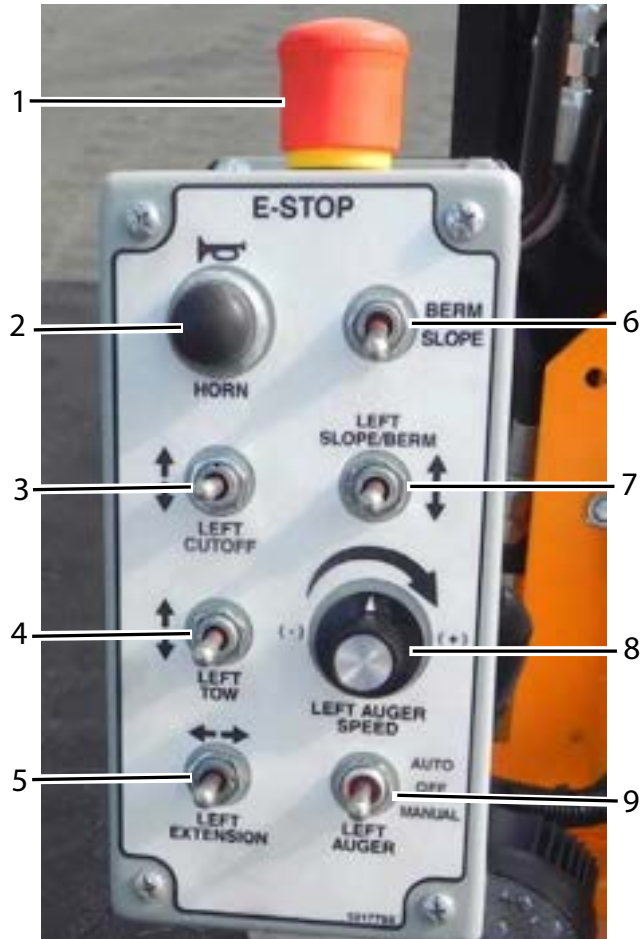

Figure 3-7. Optional 9-Function Control Box (Left Control Box Shown)

ITEM NO.	CONTROL NAME	FUNCTION
4	Tow Switch	Sets the thickness of the asphalt and controls the electric flight screws.
5	Screed Extension	Extends and retracts screed extension.
6	Berm/Slope	Selects either SLOPE or BERM function, if equipped with the optional berm attachment.
7	Slope/Berm	Raises and lowers the asphalt slope if the SLOPE switch (#6) is selected. Raises and lowers the berm attachment if the BERM switch is selected, if equipped with this option.
8	Auger Speed Dial	Controls auger speed in AUTO or MANUAL mode.
9	Auger Switch	Turns auger on and off.

ITEM NO.	CONTROL NAME	FUNCTION
1	Emergency Stop (E-Stop) Button	Immediately stops the paver engine and all electronic functions. Turn clockwise to release E-Stop button.
2	Horn	Sounds horn.
3	Under Auger Material Cut-Offs	Opens and closes Under Auger Material Cut-Offs.

4-FUNCTION REMOTE SCREED CONTROLS

The 4-function remote screed extension control boxes feature automatic auger dials above the controller box (left control box shown).

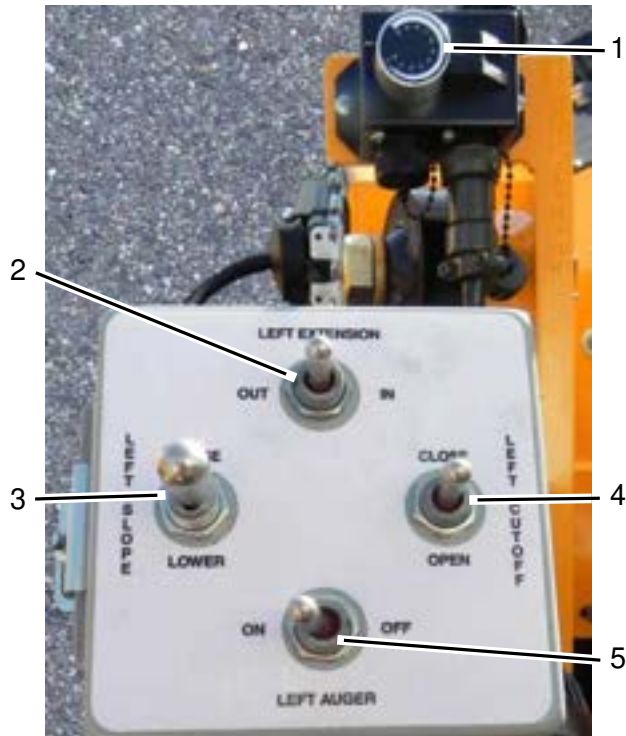

Figure 3-8. Screed Control Box (Left Box Shown)

ITEM NO.	CONTROL NAME	FUNCTION
1	Automatic Auger Dial	Controls auger height of the material in the endgate. The auger switch must be turned on to AUTO and the sonic auger sensor installed for the auger dials to function.
2	Screed Extension	Extends and retracts screed extension.
3	Slope Raise/Lower	Option: Raises and lowers the asphalt slope if equipped.
4	Under Auger Material Cut-Offs Switch	Opens and closes under auger material cut-offs.
5	Auger Switch	Turns auger on and off.

NOTES



Section 4 OPERATION

	Page
Operation	4-1
Receiving the Machine	4-3
Initial and Daily Inspection	4-3
Hopper Cylinder Valve Lock	4-3
Screed Lock Pins	4-3
Start-Up Procedure	4-4
Stopping the Engine	4-4
DPF Regeneration (REGEN)	4-4
PV480 Powerview Display	4-5
Gauge Screen	4-5
Soft Keys (Buttons)	4-5
Set Points and Throttle Speed	4-6
Main Menu Screen.	4-7
Diagnostics	4-8
System Info	4-9
Lamp Info	4-9
User Settings	4-10
Regeneration Messages.	4-12
Regen Cautions and Warnings.	4-14
Status Icons	4-17
Plus One Controller	4-18
Driving the Paver	4-18
Activate/Deactivate Operator Control Station.	4-19
Steering and Speed Control	4-19
Paver Operation	4-20
Spray Down	4-20
Heating the Screed	4-21
Hopper Wings	4-22



Conveyors	4-23
Under Auger Material Cut-Offs	4-23
Electric Flight Screw	4-24
Set the Screed Extension, Flight Screw and Endgate	4-24
Sonic Auger Sensor	4-26
Starting to Pave	4-27
Basic Paving	4-28
Setting the Crown	4-28
Mat Texture Adjustment	4-29
Unloading and Loading	4-30
Unloading	4-30
Loading	4-30
Tie-Down Procedure.	4-31
Towing	4-31
Optional Components	4-32
Auger Extensions Option.	4-32
Umbrella Option	4-32
Steering Wheel Option.	4-32
Truck Hitch Attachment Option.	4-33
HD815 (Heavy Duty) Screed	4-33
Heated Endgates	4-34
Rubber or Steel Track Options.	4-34
Topcon® Sonic and Dual Grade Control	4-35
Screed Sloping Extensions	4-35
One-Foot Screed Extension	4-35
Tunnel Extension	4-36
Automatic Temperature Control	4-36

RECEIVING THE MACHINE

The LeeBoy Model 8515E Conveyor Paver is equipped with hydrostatic-driven poly tracks that propel the paver using friction-controlled joysticks. The two conveyors are the widest in the industry to deliver asphalt more evenly and efficiently to produce a smooth asphalt mat. Electric screed heat on the main screed and each hydraulic screed extension provide seamless mats at paving widths up to 15 (4.6 m) feet.

Although the machine has been checked thoroughly by the manufacturer, road hazards or other factors during transport may result in damage. Inspect machine for any damage during transport. Contact your authorized dealer immediately if any damage has occurred. Be sure to check the machine thoroughly before operating it. (Table 4-1)

Initial and Daily Inspection

The following inspection is essential and should be performed before the initial start-up. Visually inspect the unit to check its general condition and for familiarization. Continue with a check of the systems and components shown in Table 4-1 below:

CAUTION Read this manual carefully before operating the machine. Only authorized personnel who are properly trained should operate the LeeBoy Model 8515E Conveyor Paver.

Table 4-1. Initial Inspection

INSPECT	PROCEDURE
Engine Oil Level	Maintain oil level between ADD and FULL marks on dipstick.
Fuel Tank	Check for adequate fuel supply. Fill if needed. Always fill tank at end of the day to prevent condensation in the tank.
Hydraulic Tank	Check the tank for oil level and leaks.
Radiator	Check coolant level.
Battery	Ensure all cables are tight and clean. Check for corrosion on the battery terminals.
Air Cleaner	Check the air filter element and hose connections. Air cleaner has both a primary and secondary filter.
Drain Plugs	Make sure plugs are inserted and tight.
Engine Belt	Check for proper belt tension.
Grease Fittings	Ensure fittings are greased and in good working order.

Hopper Cylinder Valve Lock

The hopper cylinder valve can be used to lock the hopper wings when they are open or closed. (Figure 4-1) Turn the valve counterclockwise to unlock the hopper wings and clockwise to lock the hopper wings.

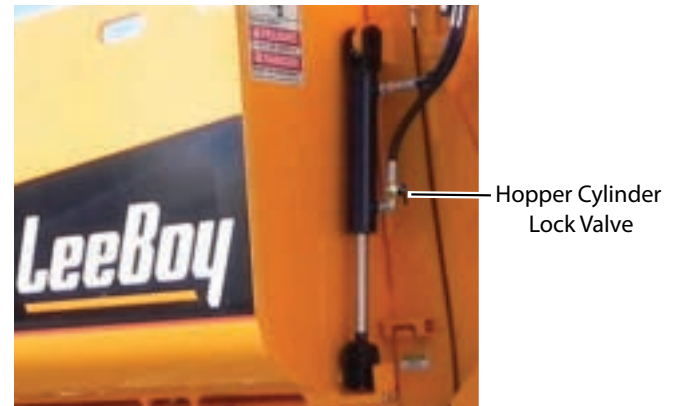

Figure 4-1. Hopper Cylinder Lock Valve

CAUTION Ensure screed lock pins and hopper cylinder valves are unlocked before extending or retracting the screed or hopper wings.

Screed Lock Pins

Screed lock pins (one on each side) adds additional safety and stability during operation and transport.

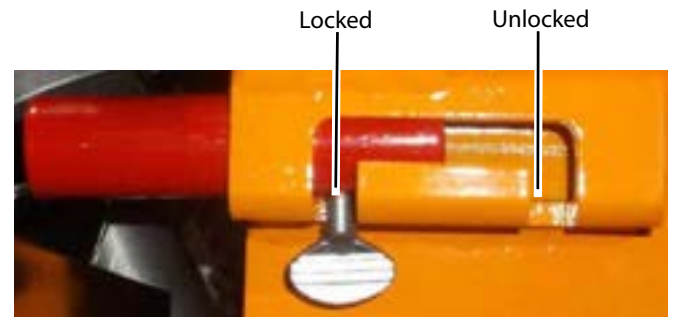

Figure 4-2. Screed Lock Pin

Figure 4-2 shows lock pin in the locked position.

To lock and unlock the screed lock pins:

- Loosen thumb screw, lift up and slide to the desired locked or unlocked position.
- Lower into desired position and retighten thumb screw.

START-UP PROCEDURE

⚠ DANGER DO NOT leave the operator station unattended while the paver is in gear or in motion. Operator must return joysticks to the neutral position and turn the RUN/STOP switch to the STOP position before leaving the operator platform.

⚠ CAUTION Verify there are no people, obstacles or other equipment in the machine's path before starting the engine.

1. Clear auger and conveyors before starting engine.
2. Position joysticks to NEUTRAL (center).
3. Insert key into the ignition and turn clockwise to the START position. The "Wait to Start" light on the control panel will illuminate.
4. Wait for the "Wait to Start" light to turn off, then turn key to the RUN position to start.

NOTICE DO NOT hold the starter longer than 10 - 15 seconds. If the engine does not start, allow the starter to cool two or three minutes.

NOTICE Using starting additives, such as ether, is not recommended as severe engine damage can occur.

5. Allow engine to warm up a few minutes before moving paver for more efficient operation. In cold weather let hydraulic oil warm to 60° (16°C) before moving.
6. Set engine RPM using the throttle up and down buttons on the Engine Screen on the digital display screen.

Stopping the Engine

1. Move joysticks to the NEUTRAL position.
2. Reduce engine to 1300 RPMs.
3. Turn ignition key on instrument panel counterclockwise to the OFF position and remove key.

NOTE: If for any reason the engine does not shut down when key is turned off, push in the E-Stop button.

DPF REGENERATION (REGEN)

When starting the engine, a sequence of screens will display on the PV480 digital display unit on the operator console. (Page 4-5) First you will see "booting" notated in the upper left corner, followed by a logo display, then the gauge screen is displayed. The lit status icons at the top of the screen will disappear momentarily.

DPF regeneration is the term given to the cleaning process where the exhaust temperature is raised in an attempt to safely burn off any soot and undesired combustion gas captured in the Diesel Particulate Filter (DPF) in the exhaust system. When the DPF filter reaches a soot saturation level between 25 - 45 percent, the onboard engine ECU (Engine Control Unit) will activate a regeneration cycle.

NOTICE To reduce the amount of particulate matter and maximize efficiency, use API-CJ4 (or ACEA-E9 European equivalent) engine oil. Running the engine at 1800 RPMs will also provide more efficient operation and allow automatic regeneration while paving.

During normal operation, the DPF is cleaned automatically. Under certain conditions, the operator may have to instruct the control system to perform the cleaning process.

The DPF icon indicates the level of soot build-up on a scale of Level 0 - 5 and changes color. Regeneration will occur automatically at Level 1 - 2.

It is important to perform a parked, manual regeneration BEFORE the engine reaches as high as Level 4. If the DPF reaches Level 4 - 5, non-warranty factory assistance from the engine manufacturer is required.

The engine speed will increase during regeneration and there may be a noticeable sound difference. Once regeneration is complete, the engine will return to normal idle speed.

Once the DPF cycle has been activated, it is important not to shut off the engine as the regeneration cycle will fail and could possibly damage the engine. If the regeneration cycle fails, the ECU may attempt a second regeneration depending upon how blocked the filter has become. If the system does not allow a second regeneration, this means the filter is blocked more than 80 percent and needs to be cleaned or replaced.

NOTICE DO NOT idle machine any longer than necessary as too much idling can cause soot to build up in the DPF, requiring more frequent regeneration.

PV480 POWERVIEW DISPLAY

Gauge Screen

The PV480 digital controller Gauge Screen is the first screen to appear when starting the engine. This is the default screen. (Figure 4-3)

Pressing the “soft key” buttons along the bottom of the controller unit allows the operator to navigate to various other screens. The banner icons along the bottom of the screen correspond with these buttons, and changes accordingly on some screens as described on the following pages. Table 4-2 shows the icons that appear on the banner with descriptions.

Pressing the Set Points button navigates to the Set Point and Throttle Speed screen. (Page 4-6) Pressing the center button (☰) always navigates to the Main Menu screen. (Page 4-7)



Figure 4-3. Gauge Screen

- 1 - After Treatment DPF Outlet Gas Temperature
- 2 - Engine Speed/RPMs
- 3 - Engine Coolant Temperature
- 4 - Electrical Potential Voltage
- 5 - Hydraulic Oil Temperature
- 6 - Soft Key Banner

Soft Keys (Buttons)

The following table shows icons appearing on the bottom banner that correspond to the soft key button, depending upon the screen mode. (Some sources may not be present on your model.)

Table 4-2. Soft Key Choices

Icon	Description
	Displays the default speed (RPMs) set points.
	Displays the DPF commands to access Uninhibit Regen and Inhibit Regen.
	Sends message to the ECU to start DPF regeneration.
	Sends message to the ECU to stop DPF regeneration. (DO NOT use unless necessary.)
	Requests freeze frame data from the ECU when faults are present.
	Navigates to the Main Menu screen where you can scroll to choose action items (such as settings and diagnostics).
	Use to scroll down through a list of items.
	Use to up scroll through a list of items.
	Select: Enters the action item selected.
	Deselect: Closes pop-up messages.
	Speed Adjustment: Adjusts throttle speed in increments. Use the (+) button to increase speed or the (-) button to decrease speed. See Page 4-6 for default speed settings.
	Increases the engine speed (RPMs).
	Decreases the engine speed (RPMs).

The gauge screen also displays engine, torque percentage, hydraulic, total hours of operation, and fuel information in the lower left quadrant of the screen. **(Figure 4-4)**

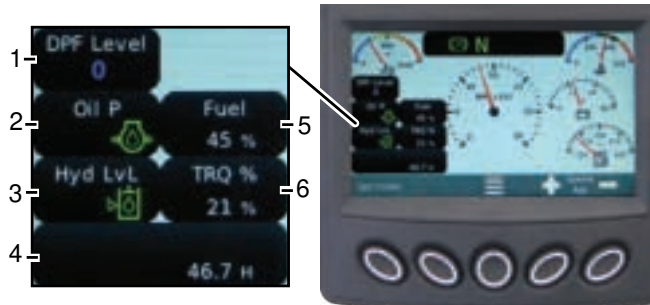

Figure 4-4. Status Quadrant

- 1 - DPF Soot Level
- 2 - Oil Pressure
- 3 - Hydraulic Oil Level
- 4 - Engine Total Hours of Operation
- 5 - Fuel Level
- 6 - Actual Engine Torque Percentage

Warning lights will illuminate and fault codes will also display:

- The hydraulic oil level or engine oil light is normally illuminated green, but will illuminate red if the hydraulic or engine oil level is too low and display a warning icon on the screen.
- A warning icon will also display if the hydraulic or engine oil temperature is too high.
- Other warning status icons may also illuminate. **(Page 4-17)**

NOTE: The DEF Tank Level icon always displays “0” as this is not applicable nor equipped on this machine.

Set Points and Throttle Speed

Pressing the Set Points button on the gauge screen navigates to the Set Points and Throttle Speed screen.

Select the desired throttle speed using the keypad buttons. The throttle speed selections are: IDLE (1300 RPMs), PAVE (1800 RPMs), and TRAVEL (2200 RPMs). **(Figure 4-5)**



Figure 4-5. Engine Throttle Speeds Screen

- 1 - IDLE (1300 RPMs)
- 2 - PAVE (1800 RPMs)
- 3 - TRAVEL (2200 RPMs)

When you turn on the heat control box to heat the screed, this turns on the generator. (Page 4-21) The IDLE throttle speed button ceases function, changing to a GENERATOR ON notification that illuminates as long as the generator is running. (Figure 4-6)

When the generator turns off, the IDLE throttle speed keypad functionality returns. (Figure 4-5)

NOTE: The generator is set at the factory to default at 1800 RPMs.



Figure 4-6. Engine Throttle Speeds Screen with Generator ON

Main Menu Screen

Pressing the Main Menu (☰) soft key navigates to the Main Menu action items. (Figure 4-7) Scroll through the list using the UP/DOWN arrow keys, then press the (◁) key when the cursor (>) points to screen you wish to view to select that screen mode. The Main Menu choices are listed below and described on the following pages:

- Gauge (default screen)
- Diagnostics
- System Info
- Lamp Info
- User Settings



Figure 4-7. Main Menu Screen

NOTICE If an active fault code is present, it will inhibit the system from performing a regeneration. This must be addressed immediately to prevent DPF soot level from reaching a level of 4 or 5, which will cause damage to the engine.

Diagnostics

Use the UP/DOWN soft keys and stop the cursor (>) for to view either active or logged diagnostics, then press the Select () soft key. **(Figure 4-8)**



Figure 4-8. Diagnostics Screen

Active Diagnostics

The Active Diagnostics screen displays active warnings or faults with the appropriate Suspect Parameter Number (SPN) and Failure Mode Indicator (FMI). **(Figure 4-9)** It may also display text description and ID/Name of the device that transmitted the message. Use the UP/DOWN soft keys to scroll through list if needed.



Figure 4-9. Active Diagnostics Screen

Logged Diagnostics

The Logged Diagnostics screen displays nonactive warnings or faults with the appropriate Suspect Parameter Number (SPN) and Failure Mode Indicator (FMI) that are stored in the system. **(Figure 4-10)** Use the UP/DOWN soft keys to scroll through list if needed.

NOTE: Select the Freeze Frame () button to request that frame data from the ECU when faults are present.



Figure 4-10. Logged Diagnostics Screen

System Info

Scroll through the Menu list using the UP/DOWN soft keys, then press the select () soft key when the cursor (>) points to the desired information. **(Figure 4-11)** The screen displays the engine model, serial number, ECU Software ID, fuel rate, and the amount of time since the last active regeneration process was performed.



Figure 4-11. System Info Screen

Press the UP/DOWN soft keys to scroll to the screen with application and configuration information. **(Figure 4-12)**



Figure 4-12. Application and Configuration Information Screen

Lamp Info

This screen shows the Diesel Particulate Filter (DPF) Lamp symbols and provides a description along with cautionary information for each symbol. Use the UP/DOWN soft keys to scroll to each symbol. **(Figures 4-13 to 4-16)**



Figure 4-13. High Exhaust Temperature Due to DPF Regeneration Symbol Screen



Figure 4-14. Needs Regenerating Screen

4



Figure 4-15. Machine Inhibiting DPF Regeneration Screen

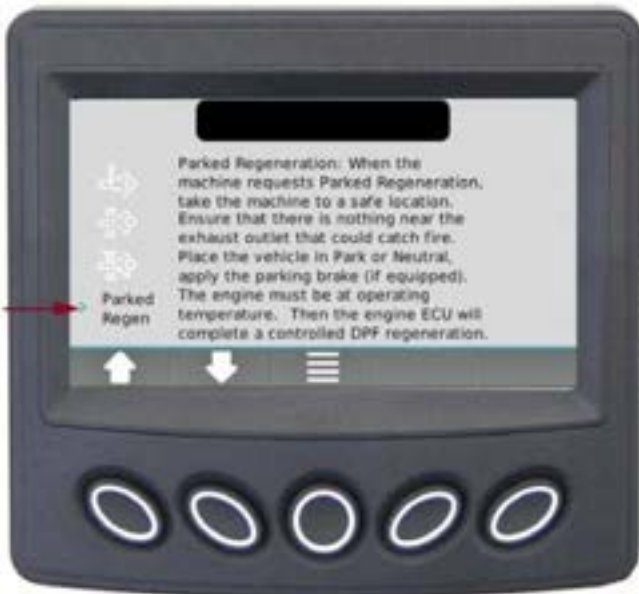

Figure 4-16. Parked Regeneration Overview Screen

User Settings

This screen displays the following action items: Screen Color; Brightness; Language; Units; Date and Time.

Screen Color

Use the UP/DOWN soft keys and stop the cursor (>) next to the action item Colors. **(Figure 4-17 and 4-18)** Set your preference for day or night vision using the +/- soft keys.



Figure 4-17. Set Night Vision Color Preferences Screen



Figure 4-18. Set Day Vision Color Preferences Screen

Screen Brightness

Use the UP/DOWN soft keys and stop the cursor (>) next to the action item Brightness. **(Figure 4-19)** Set the brightness of the backlight by using the +/- soft keys.



Figure 4-19. Set Brightness Of Backlight Screen

Units

Use the UP/DOWN soft keys and stop the cursor (>) next to the action item Units. **(Figure 4-21)** Set your unit preference using the +/- soft keys. (US Standard, Metric kPa or Metric Bar.)



Figure 4-21. Set Unit Preferences Screen

Language

Use the UP/DOWN soft keys and stop the cursor (>) next to the action item Language. **(Figure 4-20)** Set your language preference using the +/- soft keys. (English, French, German, Spanish, Italian or Japanese)



Figure 4-20. Set Language Preferences Screen

Operation

Date and Time Setting

Use the UP/DOWN soft keys and stop the cursor (>) next to the action item Date or Time. **(Figure 4-22)**

- Press the select () soft key to initiate change to the month value. Use the (+/-) soft keys to increment or decrement the number.
- Use the DOWN arrow to reach the day value and year value, using the +/- soft keys to make changes.

NOTE: A reboot is required for changes to the Date Setting to take effect.



Figure 4-22. Time Setting Screen

NOTE: Pressing the “X” button closes the pop-up messages.

Regeneration Messages

Parked Ready Regen

The machine should be maintained in an operating condition so the DPF can automatically regenerate. **(Page 4-4)** (A complete listing of Fault Codes is shown in *Troubleshooting, Section 5.*)

Table 4-3. Parked Ready Regen

Action	Description
Cancel Regen	Communicates with the engine that Regen is not wanted or is unsafe to regenerate at this time.
Regen Mode Inhibit	Communicates with the engine that Regen is not wanted or is unsafe to regenerate at this time.
Request Regen	Communicates with the engine that Regen is safe to regenerate at this time.

Regen Screens and Messages

The operator may experience a Regen Caution message on the controller screen **(Figures 4-23)**. The message requires an active response by the operator, so it is important that the operator reads the entire message as it may display instructions.



Figure 4-23. Regen Caution Message Popup Screen

Some messages require using the UP/DOWN soft keys to scroll through the entire message (**Figures 4-24 and 4-25**).



Figure 4-24. Regen Caution Message Popup Screen Example Requiring Use of UP/DOWN Soft Keys



Figure 4-25. Parked Regeneration Instructions Screen

If the operator does not wish to complete a Parked Regeneration, click the **X** soft key. This action cancels Regen, removes the pop-up message, and takes the operator back to the Gauge Screen.

NOTE: The machine must be in park and neutral with a DPF level of 2 or higher to preform Parked Regeneration.

CAUTION EXHAUST TEMPERATURES WILL BE EXTREMELY HIGH. BE SURE EXHAUST WILL NOT COME INTO CONTACT WITH ANY COMBUSTIBLE MATERIALS.

NOTE: During the regeneration, the Engine Speed will increase and there may be a noticeable sound difference. The HEST Lamp will appear during the process.

CAUTION DO NOT ATTEMPT TO OPERATE THE UNIT, CHANGE ENGINE RPM OR MOVE FROM PARK/NEUTRAL WHILE REGEN IS OCCURRING. This will abort the Regeneration process and require you to start the process over.

To perform a regeneration:

- Ensure the machine is in neutral and parking brake applied. The coolant temperature must be in operating range, typically 155° -160 F° (. Set the engine to low idle.
- Once these conditions are met, a blue screen message will appear. (**Figures 4-26 and 4-27**).
- Using the Up/Down Arrow, scroll down through the entire message and press the Request Regen Button.



Figure 4-26. Parked Regeneration Blue Screen

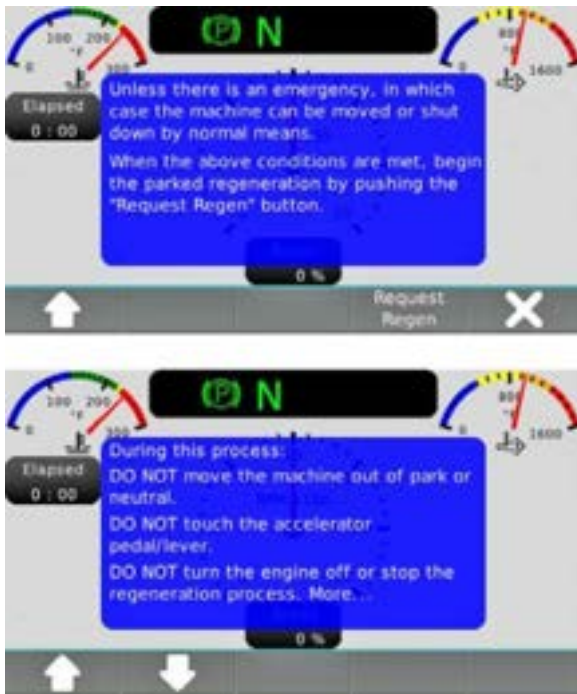

Figure 4-27. Parked Regeneration Message Screens

CAUTION Continue to monitor surrounding areas during the process. If unsafe conditions develop, shut the unit off immediately.

Parked Regeneration is complete when the screen shows the green popup message shown on **Figure 4-28**) Click on the **X** soft key to remove the popup message. When the parked regeneration process is complete, the engine will return to normal idle speed.



Figure 4-28. Parked Regeneration Green Popup Message Screen

Regen Cautions and Warnings

Pay attention to any regeneration level message shown below for operator safety and to prevent any damage if DPF regeneration is needed. (**Figures 4-29 to 4-32**)

Regen Level 1: The DPF is loaded with soot and needs to be regenerated. When safe please uninhibit automatic active regeneration. (**Figure 4-29**)



Figure 4-29. Regen Level 1 Notice

Regen Level 2: The first Level 2 screen is the warning. (**Figure 4-30**) The DPF is loaded with soot and needs to be regenerated. When safe either uninhibit automatic active regeneration or complete a parked regeneration.



Figure 4-30. Regen Level 2 Notice

Use the DOWN arrow to scroll to the second Regen Level 2 message that contains instructions for performing needed regeneration (**Figure 4-31**):

1. Move the machine to a safe location.
2. Place in Park or Neutral.
3. Set the engine to low idle.
4. Uninhibit regeneration.
5. Apply the parking brake (if equipped).



Figure 4-31. Secondary Regen Level 2 Notice

Regen Level 3: The first Level 3 screen is the warning. (**Figure 4-32**) Urgent: Engine output limited. The DPF is EXTREMELY loaded with soot and needs to be regenerated. **Continued operation without completing a parked regeneration can cause unwarranted engine damage.**



Figure 4-32. Regen Level 3 Warning

Use the DOWN arrow to scroll to the second Regen Level 3 message that contains instructions for performing needed regeneration (**Figure 4-33**):

1. Move the machine to a safe location.
2. Place in Park or Neutral.
3. Set the engine to low idle.
4. Uninhibit regeneration.
5. Apply the parking brake (if equipped).



Figure 4-33. Secondary Regen Level 2 Notice

NOTICE It is important to perform a parked, manual regeneration **BEFORE** the engine reaches as high as Level 4. If the DPF reaches Level 4 - 5, non-warranty factory assistance from the engine manufacturer is required.

Regen Level 4: Urgent: Engine output limited. DPF Regeneration is required IMMEDIATELY by a qualified engine or OEM service technician. IMMEDIATELY take the machine to a safe location, shutdown, and contact a qualified service facility. (**Figure 4-34**)



Figure 4-34. Regen Level 4 Warning

Regen Level 5: Urgent: Engine output limited. DPF Regeneration is impossible. The DPF must be removed and cleaned by a qualified cleaning facility and the ECU must be reset by a qualified engine or OEM service technician. IMMEDIATELY take the machine to a safe location, shutdown, and contact a qualified service facility. (**Figure 4-35**)









Figure 4-35. Regen Level 5

Status Icons

The Status Icons are color-coded and light up when communicating to the operator. Pay close attention to any Status Icon and its color.

Table 4-4. Status Icons

Status Icon	Description
	<p>Check Engine – When this lamp is illuminated, a fault exists within the control system. The engine may continue to operate, however, it is unable to perform DPF cleaning either automatically or manually.</p> <p>WARNING Take action immediately to correct the fault.</p>
	<p>Parking Brake Switch – The park icon displays when the parking brake is applied.</p> <p>NOTE: To perform a Parked REGEN, the “P” and “N” lamps must be illuminated.</p>
	<p>Transmission Neutral – The neutral icon displays when the transmission is in neutral.</p> <p>NOTE: To perform a Parked REGEN, the “P” and “N” lamps must both be illuminated.</p>
	<p>Engine Exhaust High Temperature Lamp – This lamp illuminates during the REGEN cycle to warn of high exhaust temperatures. This lamp will turn off when normal operating temperatures are reached after the REGEN cycle.</p> <p>WARNING Be sure engine exhaust is away from any potentially combustible materials when this is illuminated.</p>
	<p>Diesel Particulate Filter Lamp – A Solid Lamp is the initial warning that soot levels are rising in the DPF. A Flashing Lamp indicates a DPF REGEN is needed (on some systems, the lamp will become RED when flashing). The lamp will turn solid again when a REGEN is initiated.</p> <p>Any time the lamp begins flashing, the operator should increase the loading on the engine so that regeneration is possible.</p> <p>WARNING If increased load does not cause an automatic REGEN to occur, the operator should immediately perform a Parked, Manual REGEN (see reverse side for instructions).</p>
	<p>DPF Regeneration set to Inhibit – The user may choose to inhibit the REGEN if conditions are too hazardous for high exhaust temperatures. When this lamp is illuminated, a REGEN cannot be performed and soot levels will continue to rise.</p> <p>WARNING Unless hazardous conditions exist, the REGEN Inhibit switch and this lamp should remain off.</p>

PLUS ONE CONTROLLER

The Plus One is a 50-pin controller operating in the background that monitors paver control systems and alerts the operator in the event of a fault. When the Plus One controller senses a system fault, the Plus One light on the control panel (**Figure 4-36**) illuminates green and blinks continuously or blinks, then pauses, then blinks again. A complete list of fault codes with corrective action messages are shown in **Section 5, Troubleshooting**.



Figure 4-36. Plus One Light

When the key is turned on, the Plus One light will illuminate for approximately three seconds while the controller powers up, then turn off when the machine is ready to start. The Plus One will not allow the engine to start if any joystick is out of neutral or more than one Run/Stop switch is in the RUN position.

These faults will prevent machine movement:

- Steering control box not detected.
- Joystick(s) not in neutral at start-up.
- Pump control coil fault.
- Brake valve/pump neutral bypass coil fault.
- There is only one steering control box present.
- The fault happens in the steering control box that has control (Run/Stop switch in the RUN position).
- The fault occurs when neither steering control box is in control.

NOTE: The paver will start and operate with only one steering box present.

DRIVING THE PAVER

The dual operator platforms allow easy and convenient access for controls of most paver functions. (**Figure 4-37**) Controls can also be lowered to operate as a low deck or the high deck option with an assistant standing on the screed walkboard.

The paver is usually operated from the left operator station, but the paver can also be operated from the right side. Dual joysticks propel and steer the paver. An optional steering wheel control box is also available. (**Page 4-32**)

⚠ DANGER NEVER leave the operator station unattended while the paver is in gear or in motion. Operator must return joystick(s) to the neutral position and turn the RUN/STOP switch to the STOP position before leaving the operator platform.

NOTE: The engine will not start unless the E-STOP button is disengaged, the Run/Stop switch is in the RUN (center) position, and the joysticks must be in the NEUTRAL (center) position.



Figure 4-37. Dual Operator Stations

Activate/Deactivate Operator Control Station

Only one operator control station can be activated at a time for the paver to function. While the paver is typically operated from the left side, the operator can change the active station at any time using the following procedure:

1. Place both joysticks in the NEUTRAL (center) position. **(Figure 4-38)**
2. Move the RUN/STOP switch to the STOP position on the control box not being used to deactivate:
 - The Run/Stop switch controls stopping the machine and also activating/deactivating the operator control station. When the switch is set to the STOP position, that operator control station is deactivated. When switch is set to RUN, that operator control station is activated.
 - BOTH joysticks must be in the NEUTRAL position and BOTH Run/Stop switches in the STOP position to change from one steering control box to the other.
3. Activate the control box being used by setting the Run/Stop switch to the RUN position.
4. Start the engine and allow the engine to warm a few minutes.

NOTICE

If the joysticks are in the forward position and the Run/Stop switch is in the STOP position, the Plus One will disable the control box after a set period of time. This is a safety measure in the event the operator leaves the station with the control box still active. The operator must move joysticks to NEUTRAL (center) position, then toggle the Run/Stop switch from RUN to STOP and back to RUN again to regain control.

Steering and Speed Control

Use the dual joysticks for steering and speed control. **(Figure 4-38)** It is important to move the joysticks SLOWLY. Lift up on the joystick(s) and move either FORWARD or REVERSE. The joystick collar will lock back into place in the NEUTRAL position. The RUN/STOP switch applies parking brake when set to the STOP position.



Figure 4-38. Steering and Speed Control Box

- 1 - Left and Right Joysticks
- 2 - Joystick Collar
- 3 - RUN/STOP Switch

NOTE: To slow the paver, move joysticks closer to the neutral position.

NOTE: To stop the paver, pull joysticks back to the neutral position.

CAUTION Be aware of the terrain and driving conditions. Adjust speed accordingly.

- To drive the paver forward, lift up on the joysticks and push forward to reach the desired speed.
- To move in reverse, lift up on the joysticks and move backwards to reach desired speed.
- Return joysticks to the neutral position to stop paver.
- To steer the unit to the left, SLOWLY push the right joystick farther forward than the left joystick. The farther the joystick is pushed, the more the paver turns. Slow and easy adjustments are required for safe operation.

- To steer the unit to the right, SLOWLY push the left joystick farther forward than the right joystick. The farther the joystick is pushed, the more the paver turns. Slow and easy adjustments are required for safe operation.

NOTE: If the joysticks are in the forward position and the Run/Stop switch is set to the STOP position, the system will time-out after 10 minutes. You must put joysticks back into neutral and toggle the Run/Stop switch from RUN to STOP and back to RUN again to regain control.

NOTE: If equipped with the optional steering wheel control box: If the joystick steering function is not being used, the Run/Stop switch must be in the OFF position.

Stopping the Engine

1. Place joysticks to the neutral position.
2. Throttle back to idle using settings on the digital display screen.
3. Turn ignition key on the instrument panel counterclockwise to the OFF position and remove key.

NOTE: If the engine does not shut down when key is turned to OFF, press the E-Stop button on the control panel to terminate power.

NOTICE Before leaving the operator platform, the operator must return joysticks to the neutral position and switch the Run/Stop (on the Steering and Speed Control Box) to the STOP position.

PAVER OPERATION

Spray Down

Always spray down the LeeBoy Model 8515E Conveyor Paver before and after paving. It is important to pay particular attention to spraying any part of the paver that comes into contact with asphalt with solvent or release agent to prevent buildup that will damage the machine over time. Abrasive materials accumulating in sprockets, bearings, augers and conveyor components will accelerate wear and can produce tears in the paving mat if cold material breaks off and passes under the screed. The citrus tank (with green cap) is located on the main screed at the back of the paver.

There is a spray down system on both sides. The spray wand is conveniently located on each side of the operator's stations. **(Figure 4-39)** The left hose reel is located inside the engine access panel and the right hose reel is located on top of the paver.



Figure 4-39. Spray Down Wand

- Ensure the area is clear of others before spraying.
- Open the hopper wings and raise the screed.
- Allow the screed to cool at least 10 minutes before spraying to prevent possible burns from solvent spray on a hot screed. The screed should be warm, but not hot.

To operate the Spray Down system:

1. Turn the Spray Down switch on the control panel ON. **(Pages 3-6 to 3-7)**
2. Extend hose from the reel.
3. Squeeze the wand handle and spray area. Release the wand handle when finished.
4. Turns the Spray Down switch on the control panel OFF.

WARNING Never spray cleaning solvent or release agent near the screed heating element or near open flame. These agents are highly flammable and can ignite, causing serious personal injury.

NOTICE When using solvents and release agents, consider the environment and DO NOT allow cleaning solvent to run onto the ground. Only spray down the machine in a designated area away from the paving site.

Start at the front of the machine and work rearward, using a scraper if necessary, paying particular attention to ensuring built-up material is removed from:

- **Push Rollers:** Rotate the rollers while cleaning and soak bearing ends to maintain free rotation.
- **Hopper and Conveyors:** Thoroughly clean surfaces and any material accumulating in chains, drive sprockets, idler shaft, bearings and tunnel areas. AFTER cleaning the machine, operate the conveyors briefly to carry solvent into return areas where it can help dissolve hidden asphalt material.
- **Augers:** Scrape away any accumulated material around bearings and clean contact surfaces down to the metal to avoid quick build-up while paving.
- **Screed:** Face and bottom plates should be clean and smooth on the main and screed extensions to achieve a smooth paving mat.
- **Operator Platforms:** Be sure to wash away solvent residue so walk boards and operator platforms do not remain slippery.

Heating the Screed

Heating the screed helps prevent hot mix from sticking to the cold screed plate and produces a smooth, tight mat surface. This should be performed before paving and if the paver is idle long enough for the screed to cool between loads.

The LeeBoy 8515E Conveyor Paver is equipped with an electric heat system to heat the screed, including the screed extensions. A hydraulically-driven generator provides power to the electric heat control box mounted in the center on the rear side of the machine. The electric heat box is pre-wired for the heated endgates option **(Page 4-34)**. If not equipped with this option, the left and right endgate switches do not function.

This control box is where you will select the heating function before you begin to pave. It is easily accessible to the screed operator when a heating cycle is needed. **(Figure 4-40)**.

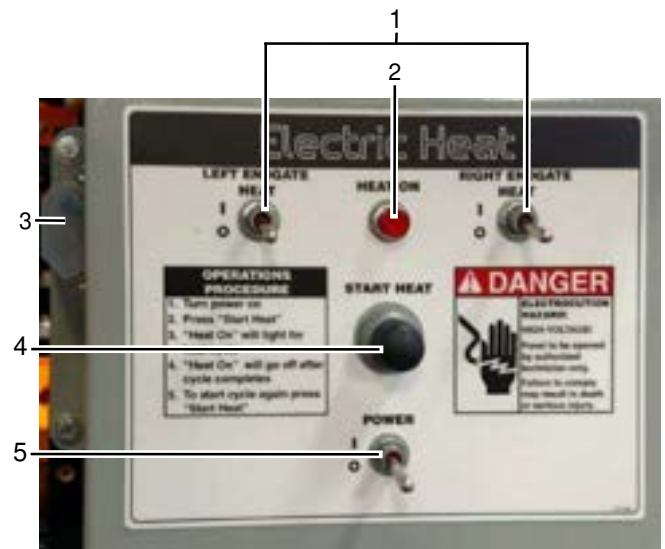

Figure 4-40. Electric Heat Control Box

- 1 - Left and Right Endgate Switches (OPTION)
- 2 - Heat On Light
- 3 - Circuit Breaker
- 4 - Start Heat Button
- 5 - Power Switch

When the heating function is enabled, the distribution/control box will apply electrical power to the screed heating elements and the heating cycle will begin. The heating cycle is timed to optimize the heat generated at the screed plates.

NOTE: Allow the screed (and screed extension) to heat 15 minutes before beginning to pave. Lower the screed two inches off the ground while heating to prevent cold air and wind from affecting the heating process.

NOTICE Running the engine at 1800 RPMs to heat the screed provides the best operating conditions. Running the engine at lower RPMs will not allow the screed to heat correctly and may damage the generator.

To operate the electric screed heating system:

1. Start the paver and idle until the engine reaches normal operating temperature.
2. Set the throttle to normal operating speed of 1800 RPMs.
3. Raise the screed plate one or two inches off the ground.
4. Turn the electric heat control box power ON by flipping the power switch up. **(Figure 4-40)**
5. Press the Start Heat button.
6. The HEAT ON indicator light will illuminate and stay on as long as the element is heating the screed. (The factory-set heat cycle is 20 minutes, which should generate enough heat to begin the paving process. Operating in cold temperatures may affect the screed plate temperature slightly.)
7. If the heat cycle has completed but the screed plates still require heating, restart the cycle by repeating Step 4.

Hopper Wings

The hopper wings are hydraulically opened so the hopper can be filled with paving material. **(Figure 4-41)** Conveyors move the asphalt back to the auger, where the mix flows through the Under Auger Cut-Offs to the screed.

CAUTION Be sure the hopper wings are unlocked before opening (or closing when in use).

To operate the hopper wings:

1. Push the hopper wings switch to OUT on the operator control panel to fold out hopper wings. **(Pages 3-6 to 3-11)**
2. Ensure the hopper wings are completely extended before receiving paving material from the truck.
3. Push the hopper wings switch to IN to close the hopper wings.

WARNING DO NOT fold in the hopper wings when the hopper is full of asphalt. DO NOT fold in the hopper until the material truck has moved completely away from the paver. Never raise the conveyor bed with asphalt in the hopper.

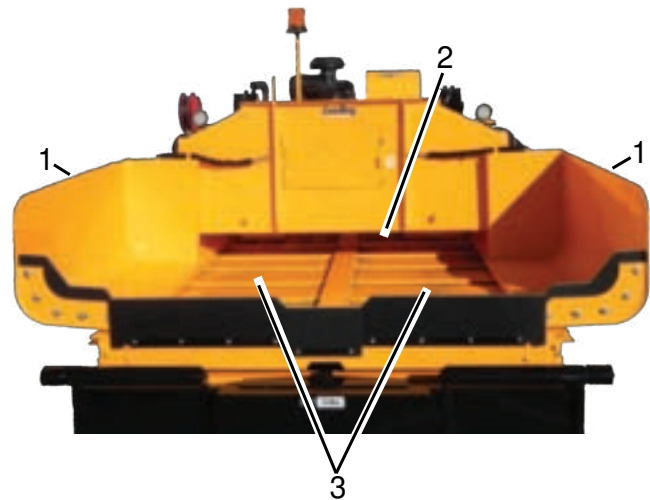

Figure 4-41. Hopper

1 - Hopper Wings

2 - Auger

3 - Conveyors

Conveyors

The LeeBoy Model 8515E Conveyor Paver is equipped with two automatic conveyors that deliver asphalt evenly to produce a smooth asphalt mat. **(Figure 4-42)**

The conveyor is a very important part of the paver that moves material from the hopper back to the auger and out of the Under Auger Material Cut-Offs to the screed. Pay close attention to integrating its operation into the total operation of the paver.

Conveyor Chains

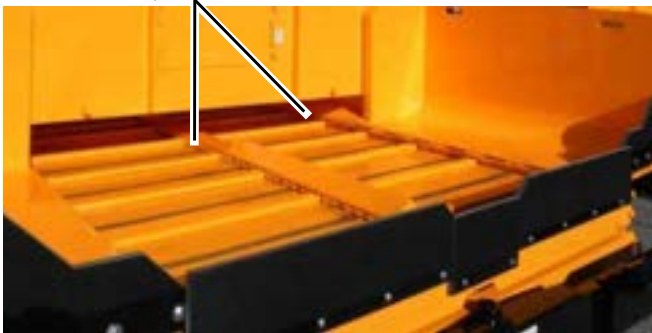

Figure 4-42. Conveyor Chains

When operating the conveyor:

- Spray down the conveyor drive chains with cleaning solvent or release agent several times during the work day for optimum performance.
- Select AUTO or MANUAL mode for the left or right (or both) conveyor switch(es) on the control panel. **(Pages 3-6 to 3-11)**
- If the conveyors are running while the cut-off gates are closed, there will be spillage, which is normal. To help prevent this spillage, work conveyors manually when loading hopper and not paving.
- Irregular movement of the conveyor indicates that the conveyor chains need adjustment. **(See Section 5)**

NOTE: Check conveyor chain adjustment every 100 hours.

CAUTION Never leave the paver unattended while the conveyor is operating. Do not leave paver running with conveyors set to AUTO for any length of time to prevent hydraulic oil overheating.

NOTICE Asphalt in the conveyors can fill tracks and cause damage to the machine. To prevent flight chains from sticking inside the conveyor pans, lubricate them daily for maximum operational efficiency.

Under Auger Material Cut-Offs

The Under Auger Material Cut-Offs are another important function of the paver, used primarily to control the flow of asphalt to the screed and hydraulic screed extensions. Cut-offs can be used to limit material flow when making narrow passes at the beginning and ending of each pass or pull. Proper use of the cut-offs minimizes clean-up at the end of pulls. **(Figure 4-43)**

- The right and left cut-off switches are used to open and close the cut-off gates and are located on both the main control panel and the screed controls.
- Pushing the switch to the OPEN positions increases asphalt flow to the screed. Pushing the switch to the CLOSED position decreases asphalt flow to the screed.

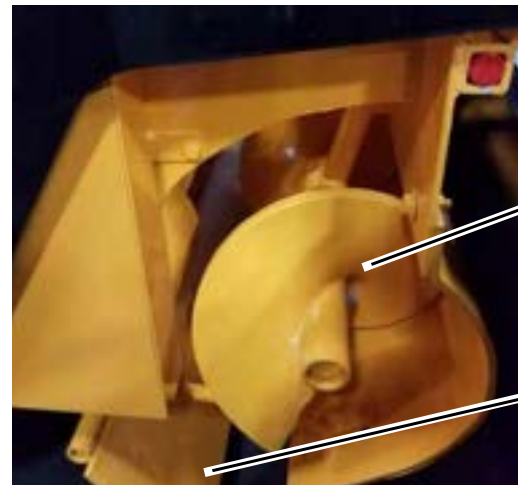

Figure 4-43. Under Auger Material Cut-Offs



NEVER back up with the cut-offs open.

Operation

Electric Flight Screw

The electric flight screw is an added convenience to the operator for making automatic, minor adjustments to mat thickness while paving. A screed height gauge is located on both sides of the paver to provide the operator with a quick reference to the location of the electric screw. **(Figure 4-44)**

NOTE: The Grade Control switch on the main control panel must be set to GRADE for this feature to operate.

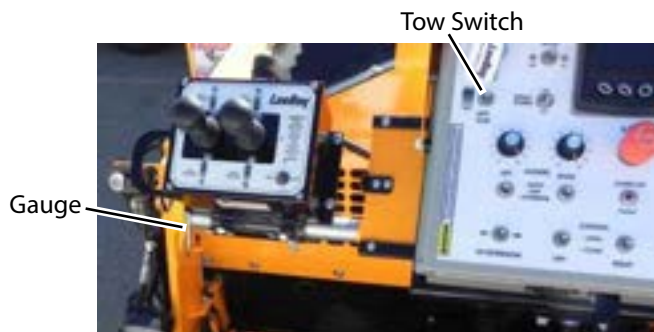

Figure 4-44. Electric Flight Screw

1. Before paving, refer to the screed elevation gauge (located on both sides of the operator platform, left side shown). **(Figure 4-44)**
2. Raise or lower the screed until the cable rod end is flush with "0" on the decal.
3. Set the Tow switch on both sides to thicker or thinner for desired asphalt thickness. **(Figure 4-44)**
4. Slowly move joysticks forward.
5. Use the Tow switch on both sides of the control panel to adjust mat thickness as you pave.
6. While paving, refer to both screed elevation gauges to make minor screed adjustments using the electric flight screw.

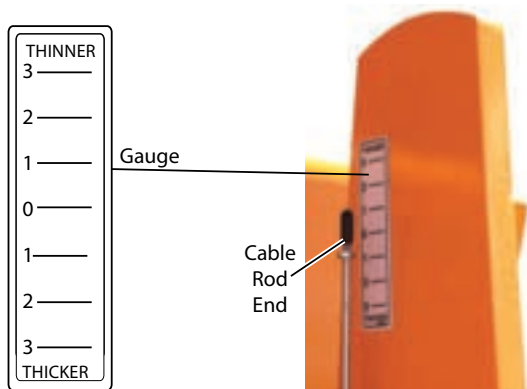

Figure 4-45. Gauge and Cable Rod End

Set the Screed Extension, Flight Screw and Endgate

The main screed and screed extensions are heated by heating elements and equipped with replaceable, heavy-duty wear plates. Use the screed extensions when paving widths exceeding eight (8) feet. **(Figure 4-46)** The screed extensions should be heated before making any adjustments using the wrench provided.

When adjusted correctly, pressure on the rear edge of the extended screed is the same as the rear edge of the main screed, resulting in a smooth mat the length of the screed.

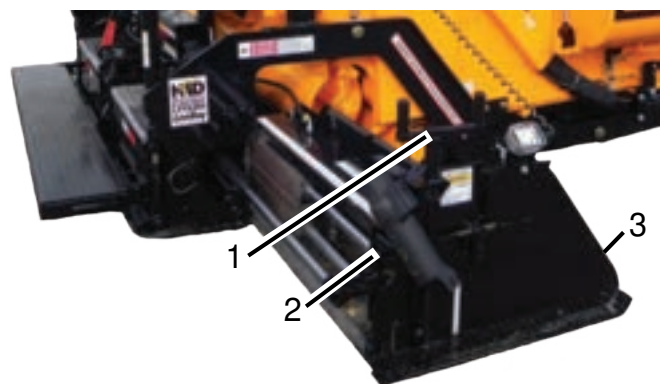

Figure 4-46. Screed, Flight Screw and Endgate (HD815 Screed Shown)

- 1 - Endgate Depth Screw**
- 2 - Endgate Tilt Screw**
- 3 - Endgate**

You can extend or retract the screed extension using the extension switch on the main control panel. **(Pages 3-6 to 3-7)**

A remote control box is provided on both sides of the main screed with switches to extend or retract the screed, set the slope, open/close the cut-offs and turn the auger on and off while paving. The paver is equipped with either a 4-Function control box **(Figure 4-47)** or 9-Function control box **(Figure 4-48)**.



Figure 4-47. Remote Control Box and Auger Dials



Additional functions on the 9-Function control box include berm and slope controls, horn, E-Stop button, auger dial, and tow switch (left box shown). **(Figure 4-48)**

The 9-function remote screed control boxes are mounted on both sides of the main screed for screed operator convenience.

Figure 4-48. 9-Function Screed Control Box

Adjust the screed extension while paving using the following procedures:

1. Move paver to the starting position for paving.
2. Extend the screed to the desired width.
3. To set the depth, you can place small starter blocks **(Figure 4-49)**

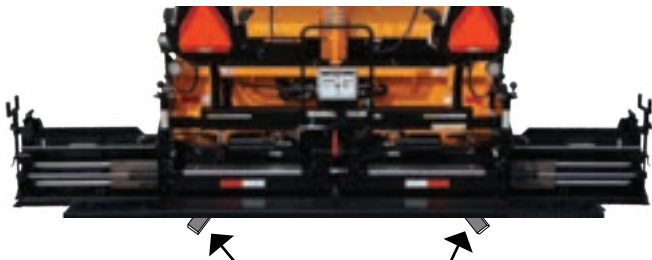

Figure 4-49. Starter Blocks Location

4. Level the screed using the electric flight screw gauge **(Figure 4-45)**.
 - Refer to the elevation gauge (one on each side of the paver for your convenience). Raise or lower until the rod end of the cable is flush with "0" on the gauge.
 - While paving, refer to both gauges and make minor adjustments if needed.
5. On the first pass, turn the endgate depth screw to lower the endgate until it is about 1/4-inch (6.35 mm) below the screed. **(Figure 4-46)**

6. Turn the tilt screw so the front of the endgate tilts down slightly when the screed is lifted. This will allow the endgate to set itself to the grade. **(Figure 4-50)**

NOTE: Never allow the endgate to carry the weight of the screed to prevent uneven compaction.

7. If the endgate digs into the asphalt at the front, adjust the tilt screw until the endgate tilts back more.
8. When making a hot joint, the endgate must be set to where it fits flush with bottom of screed.
9. On the first pass, leave approximately six to eight inches (15 - 20 cm) of unrolled asphalt where the joint will be made.
10. When making a joint, the endgate must be set to where it fits flush with bottom of screed.

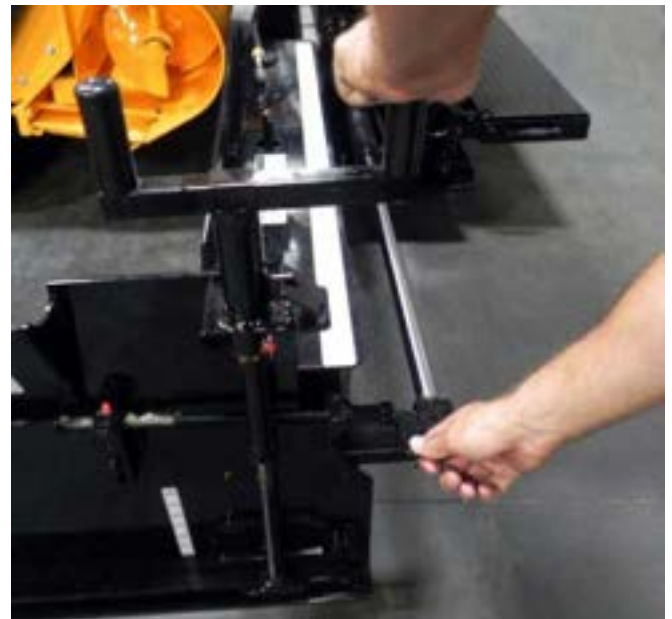

Figure 4-50. Endgate Tilt Screw Adjustment

NOTE: Keep runners clean. When making a joint, spray solvent on the runners.

11. If the joint looks too high or too low, adjust the flight screw on the screed one turn at a time and allow four to five feet (1.2 - 1.4 m) of travel to correct itself.

NOTE: Too much adjustment up or down may cause uneven pavement.

12. If making a cold joint, set the endgate down about 1/4 inch (6.35 mm) for a nice, even edge.

Sonic Auger Sensor

The sonic auger controls the amount of material flowing to the endgates, gauging the amount of paving material in the extensions. **(Figure 4-51)** The sonic auger sensors are most often used when paving widths of nine to 15 feet (2.7 - 4.6 meters) and are not used in the manual mode.



Figure 4-51. Sonic Auger Sensor

The sonic auger sensor sits in the screed mount and connects to the plug under the screed auger dial box. **(Figure 4-52)** It detects the material height and controls the auger height by automatically turning the auger on and off.

NOTE: The augers are not needed when paving under eight-feet wide (2.4 m).

To operate the sonic auger sensor:

1. Plug in the sonic auger sensor unit.
2. Set the left and right auger switches on the left side of the control panel to AUTO. **(Pages 3-6 to 3-9)**
3. Set the left and right auger On/Off switch on the remote control box to ON.
4. Adjust material height at the endgate using the auger dial beside the steering control box. **(Figure 4-52)**
 - The right and left auger dials controls material height. Turning the dial clockwise increases material height while turning counterclockwise decreases material height.
 - When the material height moves into the sonic range, the auger speed will slow down proportionately and turn off. It will turn back on when the material level drops.

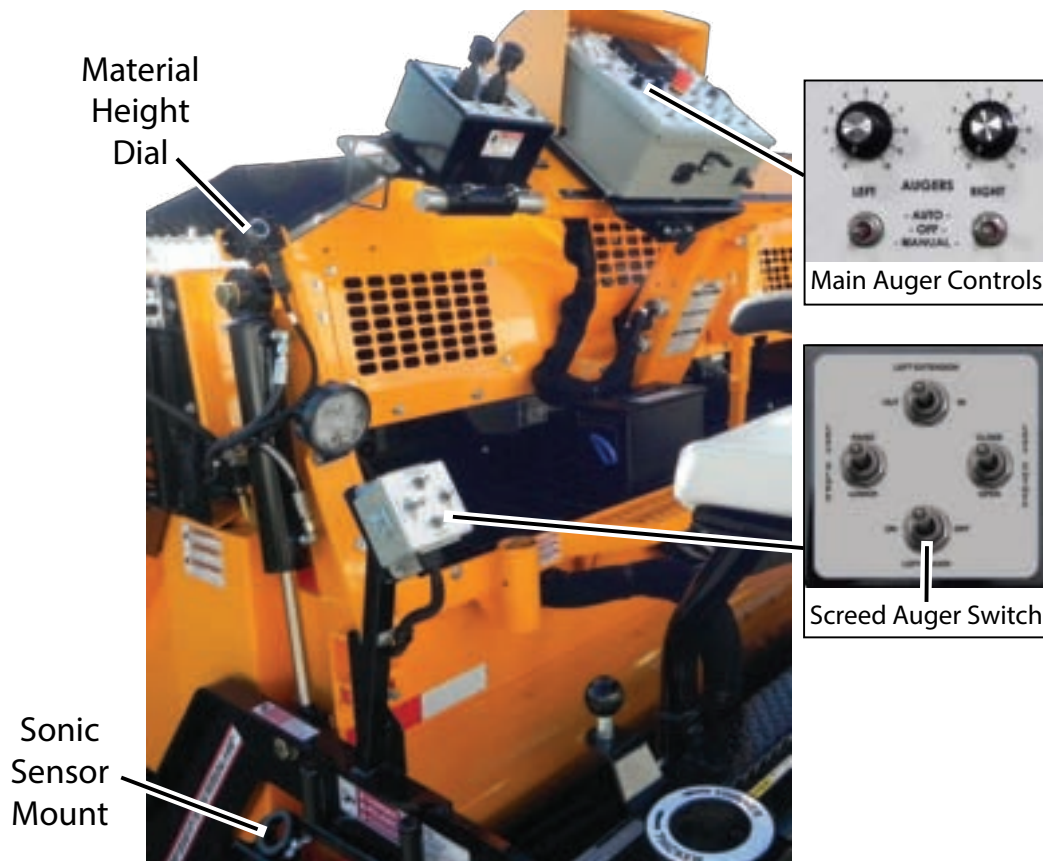

Figure 4-52. Sonic Auger Controls Sequence



Figure 4-53. Paving

STARTING TO PAVE

The LeeBoy 8515E Conveyor Paver provides superior paving for driveways, small to large parking lots, and secondary roads. The paver is equipped with electric and manual thickness controls, and can be operated from either side of the operator platform. It has a production rate of approximately 250 tons per hour or more.

This paver is capable of placing a mat thickness of six inches (20 centimeters) for:

- Bituminous base.
- Binder or surface course.
- Lime or Portland cement-stabilized sub-base.
- Graded aggregate materials.

Operators should be trained to operate the various machine components along with proper paving techniques before operating the machine.

Before starting to pave, keep these items in mind:

- Plan the project so you pave the most narrow passes first (the width of the paver), leaving the widest passes until last.
- Always pave in low range.
- It is the operator's job to guide the material truck back to the hopper and signal the driver when to stop dumping the asphalt into the hopper. The driver must maintain a light pressure on the brakes to prevent the truck from dumping asphalt onto the ground.

NOTE: If paver is equipped with the optional truck hitch, the truck driver will not be required to maintain brake pressure. (Page 4-33)

- Adjust truck push rollers to the appropriate height needed for asphalt truck. **(Figure 4-54)** Use truck hitch controls if equipped with this option. **(Page 4-33)**
 - There are five (5) set heights on the truck push rollers.
 - Remove bolts on both sides of each push roller, align with either of the five slots on the frame at desired height, and reinstall bolts.
 - Both push rollers should be at the same height to prevent damage.

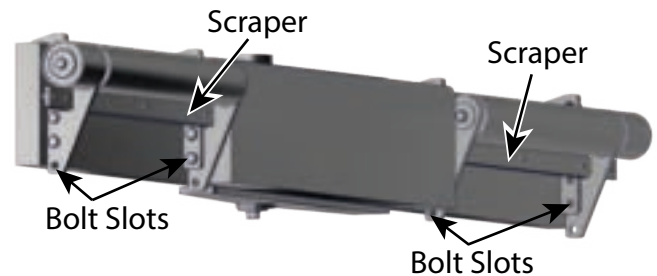

Figure 4-54. Adjustable Push Rollers

- Use a reference guide such as a curb, gutter, adjacent mat or string line.
- It is very important that the first pass be straight as it will serve as your guideline for the following passes.
- Extend the lower guide bar gauge to further assist you in paving a straight line from the operator's station. **(Figure 4-55)**



Figure 4-55. Lower Guide Bar Gauge

CAUTION Avoid low limbs, power lines, and other objects that can endanger crew or paver.

Basic Paving

1. Position paver at the starting point for the mat.
2. Open Under Auger Material Cut-Offs. **(Page 4-23)**
3. Adjust screed as needed. **(Pages 4-24 and 4-25)**
4. Open hopper wings to accept asphalt from the material truck. **(Page 4-22)**

NOTE: Allow only a partial load of asphalt to enter the hopper when first starting to pave.

6. Turn the left and right conveyor switches to the AUTO position.
7. When the material begins to discharge from under the screed, set the screed lift switch to the FLOAT position. **(Pages 3-6 and 3-7)**
8. If paving a width more than eight feet, turn the left and right auger switches to AUTO to control the material height at the endgate. (Augers aren't needed when paving a basic eight-foot pull.)
9. When the material starts moving into the sonic range, the sonic auger will automatically regulate the auger operation.

NOTE: The material height must be set to the highest point when the endgates are closed. When the endgates are open, the material height will lower to prevent material from pushing in front of the endgates.

10. Begin paving, moving slowly at first to adjust the screed if needed.
11. Make a paving pass until the asphalt level in the hopper is low.

CAUTION Never back up with cut-off gates open.

NOTE: To prevent excessive handwork, set the left and right conveyor switches to the OFF position and set both cut-off switches to the CLOSE position about three feet from the end of the pull to prevent excessive handwork.

12. Return paver back to starting position to begin the next pull.
13. Position and set the screed endgate on the joint side back to "0" feet, or flush with bottom of the screed.
14. Repeat these steps as you continue to pave.

Setting the Crown

The screed can also be set to control the pavement slope, or crown. A pavement crown is the elevation of the middle in relation to the edges, and insures proper drainage of the pavement.

NOTE: Maximum crown is two inches.

To adjust the crown:

1. Loosen the lock-down bolts in slotted bars before adjusting crown and valley mechanism. **(Figure 4-56)**



Figure 4-56. Loosen Lock-Down Bolts

2. Use the crown handle adjuster for setting positive or negative crown: **(Figure 4-57)**

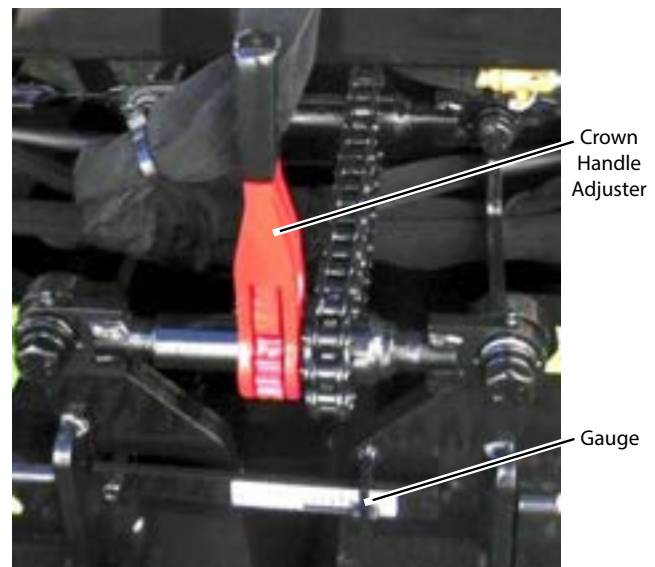

Figure 4-57. Crown Adjustment

- For increased positive crown push down on adjuster.
 - For increased negative crown pull up on adjuster.
3. Use the gauge at the center of the screed above the standing platform. If the needle is above the zero, you will have positive crown. If the needle is below the zero, you will have negative crown.
 4. To get exact crown or valley, measure the distance between a flat level surface to the center bottom portion of screed. Make adjustments with crown and valley control.
 - Positive crown is when the middle of the mat is raised to permit water to drain to each side. **(Figure 4-58)**
 - Negative crown is the lower in the center of the screed plate, often used in an alley where drainage is necessary. **(Figure 4-58)**

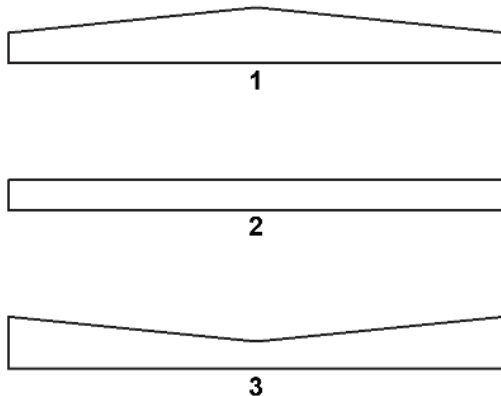

Figure 4-58. Crown Settings

- 1 - Positive (+)
- 2 - Zero (0)
- 3 - Negative (-)

NOTE: Crown may be placed in the leading edge and/or the trailing edge of the screed plate. Crown in the leading edge aids material flow under the screed plate only. Trailing edge crown puts a crown in the mat.

Example: The trailing edge crown is 0 and the leading edge crown is 1/8 inch. There will not be any crown in the mat, but the material flow under the screed plate will be improved.

Mat Texture Adjustment

There are three adjusters in each screed extension, however the adjusters at each end are preset by the dealer and do not need adjustment.

Adjust the mat texture using the Angle-of-Attack (AOA) adjustment screw in the center to produce a smoother or coarser mat texture. **(Figure 4-59)**

- The screed extension should be hot before making any adjustments.
- Spray the bottom of the screed with cleaning solvent BEFORE heating the screed.

CAUTION NEVER spray cleaning solvent or release agent on or near a hot screed heating or near open flame. Cleaning solvent and release agents are flammable and could cause serious personal injury.

NOTE: Do not allow release agent chemicals to run onto the ground.

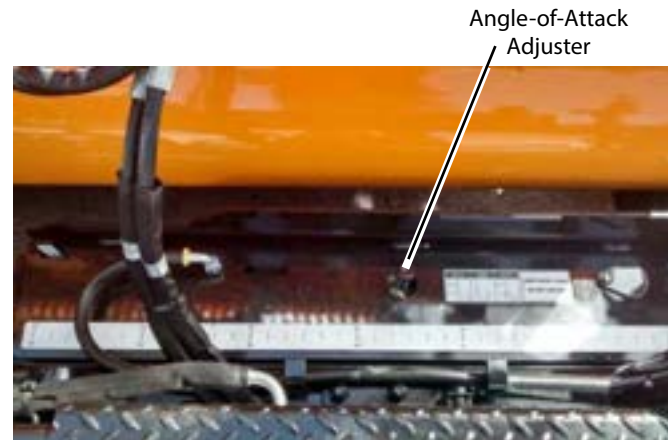

Figure 4-59. AOA Adjustment

To make the AOA adjustment:

1. Spray down and heat the screed extension if needed.
2. Turn the AOA adjuster in the direction for desired result:
 - Turning the AOA adjuster counterclockwise will increase the pressure on the back of the extension, which gives a smoother, slicker finish.
 - Turning the adjusters clockwise will decrease the pressure on the back of the extension, resulting in a coarser finish.

NOTE: Too much pressure on the back of the screed extension will take the weight off the screed wearplate and cause poor material compacting, resulting in a poor finish.

UNLOADING AND LOADING

Ensure the transport trailer has the capacity to carry the paver's weight. Park the trailer in a clear, level area when loading or unloading the machine.

CAUTION ALWAYS position an assistant to be a ground guide when loading and unloading the paver.

CAUTION Work slowly and carefully to avoid accidents. Keep the loading area clear.

WARNING ALWAYS back the paver up loading ramp with the screed end first. ALWAYS be alert to uneven surfaces and the potential reactions when transferring the paver from surface to surface. Serious injury or even death can result.

WARNING Use extra caution steering when loading and unloading the paver as slight steering changes on ramps and trailers can cause the machine to fall off the ramp or transport trailer. Serious injury or even death can result.

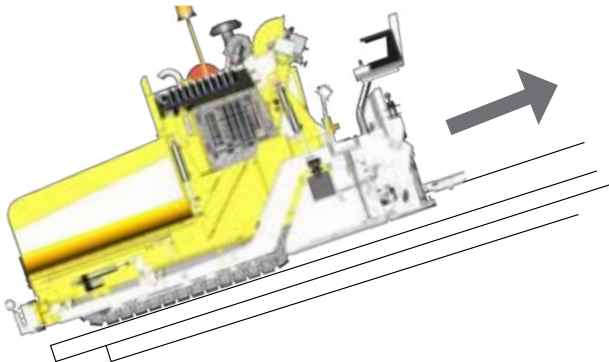

Figure 4-60. Correct Loading and Unloading Position

Unloading

1. Remove tie-down equipment.
2. Start and warm up engine.
3. Set throttle at half the operating RPMs, but enough to ensure the hydraulic pump is providing sufficient flow to operate all functions properly.
4. Set steering control lever so paver moves very slowly.
5. BEFORE moving the machine, ensure:
 - The screed position is UP.
 - Auger extensions are removed.

- The extendible screed is IN.
- The Under Auger Material Cut-Offs below the augers are CLOSED.

6. Move paver SLOWLY down the ramp.

NOTICE Never move the paver in reverse while the cut-offs are open.

CAUTION DO NOT allow the screed to strike the ramp as this can damage bearings on the thickness control screws or welds on the leveling arms. A longer ramp to reduce the loading angle may be needed.

Loading

CAUTION To prevent damage to the undercarriage and throughout the paver, reduce traveling speed before the paver tracks come into contact with loading ramps or any abrupt change in the surface. The track drive sprocket or other components can be damaged by excessive shock.

CAUTION The paver must be loaded screed-end first to prevent damage.

1. Move paver to base of ramp. Line up tracks with the ramp.
2. BEFORE moving the machine, ensure:
 - The screed position is UP.
 - Auger extensions are removed.
 - The extendible screed is IN.
 - The Under Auger Material Cut-Offs are CLOSED.
3. Load the paver screed-end first. Set throttle at half the operating RPMs.
4. Set steering control lever so paver moves very slowly onto the ramp.
5. Using the steering control joysticks, SLOWLY guide paver up the ramp.
6. Position paver in center of trailer.
7. Lower the screed.
8. Shut down the engine.
9. Secure paver to transport using the following tie-down procedures.

Tie-Down Procedure

1. Position paver in center of the trailer.
2. Attach tie-down chains to the front weight block and the D-Rings in front of the torque hubs. **(Figure 4-61).**
3. Place chocks at wheels or tracks.
4. Attach tie-down chains to rear truck bed and the paver D-Rings on main screed.
5. Ensure that all chains are tightly secured before transporting the paver.

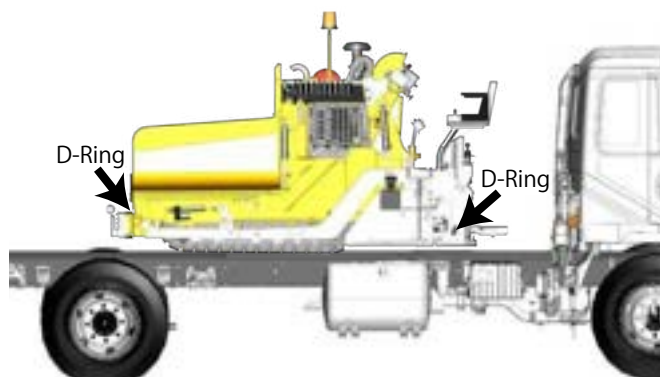

Figure 4-61. Tie-Down D-Ring Locations

TOWING

WARNING Ensure the paver is on level ground and blocked to prevent machine from moving while preparing for towing. Be especially careful after disconnecting the torque hub as the paver could roll.

While it is strongly recommended that the paver be transported rather than towed, there are situations where you may need to tow the paver off the road until a transport vehicle arrives. Do not tow paver long distances.

You must disconnect the torque hub to prepare the machine for towing as follows:

1. Using a wrench, loosen one of the two bolts on the torque hub cap, then remove the other bolt and retain for next step. **(Figure 4-62)**



Figure 4-62. Remove Cap Bolts

2. Slide cap over and insert retained bolt into the center of the hub. **(Figure 4-63)** This allows you to pull the release mechanism out, which disconnects the torque hub.



Figure 4-63.

NOTICE Be sure to push release mechanism back into place and reinstall/tighten bolts on cap when finished moving the paver.

OPTIONAL COMPONENTS

Auger Extensions Option

The auger extensions should be attached to the main auger to increase the flow of asphalt to the endgates and screed extensions when paving at wider widths. This makes it possible to lay asphalt at a higher rate. Auger extension options are 12-inch extensions for each side or 24-inch extensions with shields for each side.

NOTICE Left and right auger extension covers or shields must be installed on the correct side of the machine.

To attach the auger extensions proceed as follows:

1. Identify the right and left auger extensions by observing the left or right on the end of the auger extension shaft.
2. After identifying the right and left auger extensions, extend the screed extension fully as follows:
 - Set the left and right auger switches to the OFF position.
 - Set the left and right extension switches to the OUT position and extend fully.
3. Shut off engine.

WARNING Serious injury can result when attaching extensions if the engine is running.

4. Remove bolt, nut cap on end of main auger.
5. Attach the correct side auger extension to the main auger with hardware just removed.
6. Secure end of extension auger to main auger.
7. Install guard. Make sure extension auger is running flat.
8. Repeat this procedure for opposite side.

Umbrella Option

The umbrella kit option provides shelter from sun and other weather conditions for the operator. The umbrella kit assembly includes the mounting bracket and umbrella frame assembly that can be mounted on either side of the screed handle.

Steering Wheel Option

A steering wheel option is also available in lieu of joystick steering. (Figure 4-64) The Run/Stop switch on the steering panel controls running and stopping the machine, and applies parking brake when set to the STOP position. The joystick controls forward and reverse travel along with speed.



Figure 4-64. Steering Wheel Option

- 1 - Forward/Reverse
- 2 - Steering Wheel
- 3 - Run/Stop Switch

- To drive the paver forward, push joystick forward to reach the desired speed.
- To move in reverse, pull joystick(s) and move backwards to reach desired speed. A back-up alarm will automatically turn on when in reverse.
- To slow the paver, move joysticks closer to the neutral position.
- Return joystick to the neutral position to stop paver.

NOTE: If the joystick steering function is not being used, the Run/Stop switch must be in the center OFF position.

NOTE: The engine will not start unless the E-STOP button is disengaged and the joystick must be in the NEUTRAL (center) position.

Truck Hitch Attachment Option

The truck hitch is an optional attachment that prevents excessive and uneven braking from the paving material truck. **(Figure 4-65)**

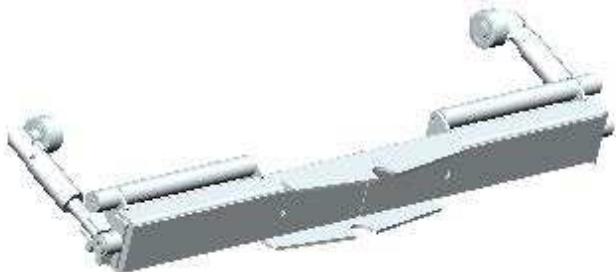

Figure 4-65. Truck Hitch Attachment Option

If equipped with this option, a truck hitch lever (valve) is located inside the left engine access panel behind the spray down hose reel. **(Figure 4-66)** This lever is factory set for the truck hitch. You will only need to shift the lever in the opposite direction when raising the conveyor **(Page 5-4)**. **Be sure to return the lever to its original truck hitch position after lowering the conveyor back into place.**

To engage the hitch with the rear wheels of the asphalt truck:

1. Extend the arm extensions of the truck hitch by pushing and holding the Truck Hitch button in the OUT position.
2. The paving material truck then SLOWLY backs up to the paver until the hitch makes contact with the rear tires of the truck.
3. Retract the arm extension by pushing and holding the Truck Hitch switch in the IN position until both guide rollers are fully locked onto the truck wheel rims.

NOTE: It may be necessary to adjust the roller guides to the inside of the wheel rims.

Truck Hitch Lever

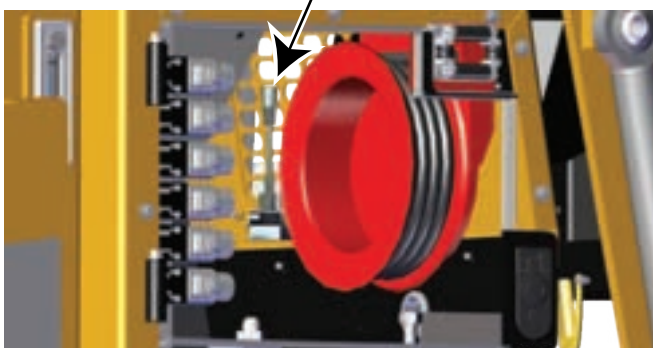

Figure 4-66. Truck Hitch Lever

Power Crown Option

The Power Crown option automatically adjusts the positive or negative crown as needed.

The power crown option can only be used on the right screed extension. The power crown selector switch is located beside the electric heat control box. **(Figure 4-67)**

To use the power crown feature:

1. Turn power crown selector switch ON to activate the power crown. **(Figure 4-67)**
2. The right extension switch on the remote control box now controls the power crown feature.
3. Turn the power crown selector switch OFF when not using this feature in order to extend/retract the right screed extension.



Figure 4-67. Power Crown Option

HD815 (Heavy Duty) Screed

The Legend 815HD Screed option offers numerous features for paving professionals. The main screed and screed extensions are electrically heated by six (6) 1000-watt blade elements (four on the main screed and one on each screed extension) and is equipped with replaceable, heavy-duty wear plates. Dual vibrators, heavy-duty flight screws, heavy-duty crown-and-valley mechanism, and a 3-Adjuster AOA with vertical height adjustment for even more screed control.

Berm Screed Extension Attachment

The Berm Screed Extension Attachment (HD Screed only) allows you to adjust the last one foot of each extension to pave up to a four-inch roll-up curb. **(Figure 4-68)** You can also raise the height to easily allow more material alongside buildings or other objects on various paving jobs. The berm attachment is adjustable while paving and controlled via a remote toggle switch.



Figure 4-68. Paving with Berm Attachment

The berm attachment is adjustable while paving. To operate:

- Place toggle switch in the BERM position to raise and lower the berm attachment.
- Place toggle switch in the EXT position to move the screed extension in or out.

Heated Endgates

The heated endgate also heats the edge of the endgate, producing a smoother joint as you pave. **(Figure 4-69)** (When the heated endgate is turned on, the leading heating element turns off on the side you're heating.) The heated endgate switches are located on the electric heat control box.

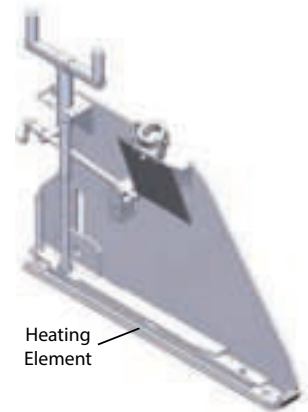

Figure 4-69. Heated Endgate

To operate the heated endgates:

1. Start the paver and idle until the engine reaches normal operating temperature.
2. Raise the screed plate one or two inches off the ground.
3. Turn the electric heat control box power ON by turning the power switch up.
4. Press the Start Heat button. The HEAT ON indicator light will illuminate and stay on as long as the element is heating (approximately 20 minutes).
5. Turn the left or right endgate switch up to the ON position.
6. You can restart the cycle by repeating Step 4 if needed.

Roll-Up Curb Attachments

Roll-up curb attachments are also available options for one or both sides of the paver. Roll-up curb attachments are available in lengths of 12 or 24 inches.

Rubber or Steel Track Options

The LeeBoy 8515E paver is equipped with poly-pad tracks. However, steel or rubber track options are available in lieu of the poly-pad tracks.

Topcon® Sonic and Dual Grade Control



Topcon® sonic grade control, dual grade control and slope options offer paving professionals screed control for improving smoothness along with assuring accurate slope and material thickness. These controllers send signals to the screed to precisely maintain mat thickness and slope as you pave.

Figure 4-70. Sonic Grade Control

Sonic trackers continuously measure the elevation over the surface, automatically averaging and adjusting the tow point cylinder on the paver. The LCD digital display is easy to see regardless of light conditions.

Choose from one of three options: Sonic Grade Control (one side); Dual Grade Control or Dual Grade Control and Slope (both Topcon P-32 systems). The dual grade controls automatically maintain a set depth on both ends of the screed. The Dual Grade and Slope controls maintain a set depth on one end of the screed and as slope to the other end.

Most states require this technology for state road paving jobs to ensure smoothness and continuity on roadways.

Screed Sloping Extensions

The sloping extensions option provides the means of matching curb and gutter to reduce handwork while paving. **(Figure 4-71)** The hydraulic slope extensions provide 0 - 8 percent slope.

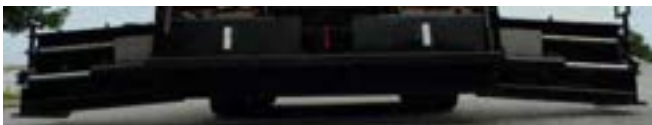

Figure 4-71. Screed Sloping Extensions

One-Foot Screed Extension

The 1-foot screed extension is an option only available on the HD815 (Heavy Duty) screed option. The extension attaches to the main screed extensions, extending paving width from 7 - 9 feet (2.1 - 2.7 m).

To attach the 1-foot extension:

1. Extend both main screed extensions.
2. Remove both endgates.
3. Install each 1-foot extension on correct side.
4. When both are installed, set wearplates flat with the main extension using the vertical lift adjusters and AOA adjuster. **(Figure 4-72)**
5. Reinstall endgate.

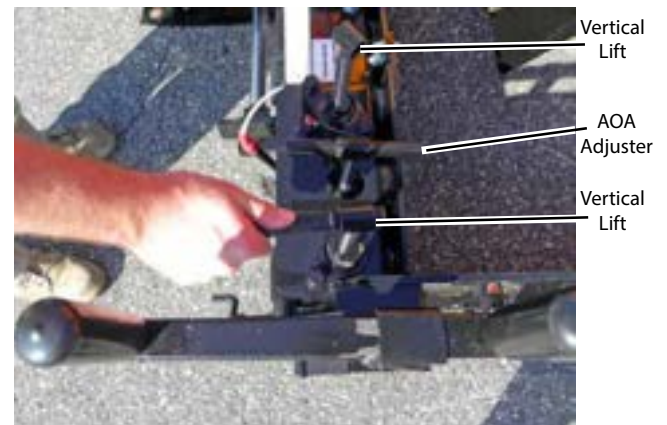

Figure 4-72. One-Foot Screed Extension

Tunnel Extension

The tunnel extensions attach to the rear of the paver. **(Figure 4-73)** This attachment allows material to flow while paving at wide widths.

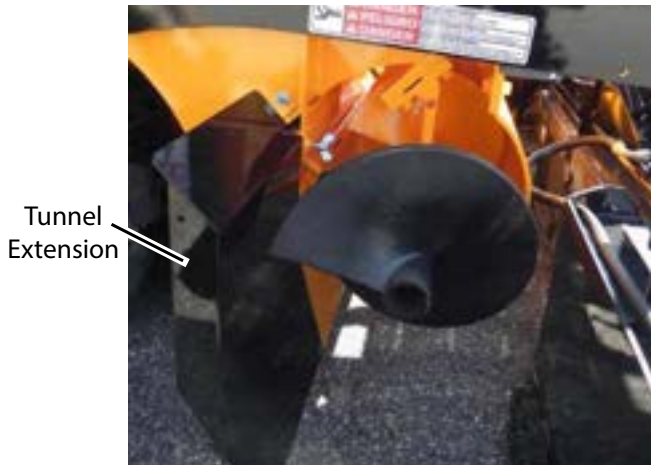

Figure 4-73. Tunnel Extension

To attach the tunnel extension:

1. Loosen the wing bolt on extension.
2. Remove the tube cover.
3. Slide tunnel extension into the tube.
4. Tighten the wing bolt.



Figure 4-74. Automatic Temperature Control Box

Automatic Temperature Control

Automatic temperature control for heating the screed is an option that offers additional convenience for operators, automatically turning the heating elements on and off to maintain desired screed temperature. **(Figure 4-74)**

The green numbers that illuminate on the controller is the set point temperature. Use the UP and DOWN arrows to increase or decrease the set point temperature. The screed temperature appears in red numbers above the set point temperature. **(Figure 4-75)**



NOTE: DO NOT push other buttons as they are for service technician access only.

Figure 4-75. Automatic Temperature Controls

Start with a set point temperature of 200° - 250° F (93.3° - 121° C). The screed runs warmer than the set point temperature due to heat soak, which is normal, so it's better to start with cooler a temperature set point. The displayed temperature (in red) must fall 25 degrees below the set point before the heating elements turn on again.



Section 5

MAINTENANCE

	Page
Maintenance	5-1
Maintenance Schedule	5-3
Raising and Lowering Conveyor	5-4
Routine Maintenance	5-5
Preparing Paver for Maintenance	5-5
Every 10 Hours or Daily Routine Maintenance	5-5
Every 50 Hours or Weekly Routine Maintenance.	5-5
Every 100 Hour or Monthly Maintenance	5-6
Every 250 Hours or Quarterly Routine Maintenance	5-6
Every 500 Hours or Semi-Annual Routine Maintenance	5-6
Every 1000 Hours or Annual Routine Maintenance	5-6
Torque Hub Lubrication	5-6
Lubrication Points	5-7
Maintenance Adjustments	5-8
Conveyor Flight Chains	5-8
Conveyor Drive Chain	5-8
Auger Drive Chain Adjustment	5-9
Screed Extension Top Guide Adjustment	5-9
Track Tension Pressure Relief	5-10
Conveyor Switch Adjustment	5-10
Torque Hub Hydraulic Motor Gear Adjustments	5-12
Engine Maintenance	5-12
Check Engine Lubrication Oil	5-13
Change Engine Oil and Filter	5-13
Change Air Filter	5-14
Engine Drive Belt	5-14
Fuel System	5-15
Fuel Tank	5-15
Change Fuel Filter.	5-15
Fuel Water Separator	5-16



Hydraulic System	5-16
Check Hydraulic Oil	5-16
Change Hydraulic Oil and Filter	5-17
Electrical System	5-18
Battery Servicing	5-18
Alternator	5-19
Electric Heat Control Box	5-19
Generator	5-21
Generator Capacitor	5-22
Dielectric Grease	5-22
Replacement Procedures	5-23
Front Idler	5-23
Track Tension Cylinder	5-24
Track Rollers	5-24
Track Sprocket (Steel or Poly).	5-24
Rubber Track (Option)	5-25
Torque Hub	5-25
Two-Speed Hydraulic Motors	5-26
Rear Conveyor Shaft, Bearings and Sprockets	5-28
Conveyor Drive Motors	5-28
Auger and Inner Bearings	5-29
Auger End Mounts	5-30
Auger Motors	5-30
Main Screed Wear Plate.	5-31
Screed Extension Wear Plate	5-32
Conveyor Switch Replacement	5-33
Replace Radiator Hoses	5-33
Weldment	5-34
Winterizing for Storage.	5-35
Troubleshooting	5-36
Spraydown Pump	5-36
Hydraulic Motor Installation Start-Up Procedure	5-37
Hydraulic Test Ports.	5-38
Auger and Conveyor Chain Tension Adjustment	5-39
Troubleshooting Chart.	5-40
PV480 Diagnostic Trouble Code (DTC) Chart	5-43
PV480 Troubleshooting.	5-51
Plus One Controller	5-52

MAINTENANCE SCHEDULE

Before performing any maintenance procedures on the LeeBoy Model 8515E Conveyor Paver, review the safety information in **Section 1**.

WARNING Always use the appropriate and correct sized tools for the task at hand to prevent damage or possible injury.

WARNING Always wear heat-resistant gloves when handling hot components.

Following the maintenance schedules and procedures

will maintain the paver in top operating condition and provide years of trouble-free operation. Refer to the Engine Operator's Manual accompanying your paver for more detailed engine service information.

When performing any routine maintenance, always include the previous routine maintenance hours in the higher hourly schedule.

NOTICE Changing oil and cleaning the paver should only be done in a designated area where the oil and chemicals can be contained. These by-products should be discarded in accordance with environmental regulations.

Table 5-1. Periodic Maintenance Schedule

SYSTEM	ITEM	Every 10 Hours Daily	Every 50 Hours Weekly	Every 100 Hours Monthly	Every 250 Hours Quarterly	Every 500 Hours Semi-Annually	Every 1000 Hours Annually
Paver	Lubricate paver.	X					
Engine	Check oil level.	X					
	Check coolant level.	X					
	Replace coolant.					X	
	Check air filter.		X				
	Change air filters.				X		
	Replace fuel filter.				X		
	Change oil and oil filter. (Initial 50 Hours)				X		
	Adjust main engine belt.				X		
	Replace main engine belt.					X	
Hydraulic	Check hydraulic oil level.	X					
	Change hydraulic oil.						X
	Change hydraulic filter.				X		
	Check torque hub oil.		X				
	Change torque hub oil.					X	
	Drain hydraulic tank. Replace strainer.						X
Mechanical	Adjust conveyor drive chains.			X			
	Adjust conveyor flight chains.			X			
	Adjust auger chains.			X			
	Adjust screed extension top guide.			X			

RAISING AND LOWERING CONVEYOR

The conveyor bed can be hydraulically lifted for easy access to the undercarriage and tracks for cleaning, maintenance and adjustments. **(Figure 5-1)**

NOTE: Engine must be running to raise the hydraulic conveyor bed, but can be turned off while unbolting the side wings.



Figure 5-1. Hydraulic Conveyor Bed in the Raised Position

Use the following procedures to raise and lower the conveyor.

NOTE: If equipped with the optional truck hitch, the truck hitch lever valve inside the left engine access panel must be shifted in the opposite direction to raise the conveyor bed. Be sure to return the lever back to its original position after lowering the conveyor back into place. (Page 4-33)

1. Fold in the side wings by pushing the Side Wings In/Out switch to the IN position.
2. Remove bolts on side wings using the wrench provided with your machine. **(Figure 5-2)**



Figure 5-2. Remove Side Wing Bolts

3. Grasp top of the side wing with one hand and the handle with the other, and carefully pull out five to six inches (13-15 cm). Then pull bottom handle out until the side wing folds out from the bottom hinge. **(Figure 5-3)** Repeat for the other side.



Figure 5-3. Fold Out Side Wings

4. Raise conveyor by pushing the Conveyor Raise/Lower switch to the RAISE position and hold until conveyor is fully raised. Immediately after raising the hopper, place the safety prop in position. **(Figure 5-4)**



Figure 5-4. Safety Prop in Position

WARNING Crush Hazard! Safety prop must be placed in position. Use extreme care when working under conveyors. Clear the area of untrained personnel.

Lowering Conveyor

CAUTION Remove all tools or foreign objects before lowering and clear the area of untrained personnel.

1. Before lowering the conveyor, make sure that the area under the conveyor is clear of tools or foreign objects.
2. Turn engine ON and raise conveyor off safety prop.
3. Release safety prop carefully.
4. Lower the conveyor by flipping the Conveyor Raise/Lower switch to the LOWER position and hold until conveyor is fully lowered.

ROUTINE MAINTENANCE

Preparing Paver for Maintenance

WARNING If any maintenance must be performed while the engine is running, DO NOT leave paver unattended.

1. Park the paver on a flat surface.
2. Lower all attachments to ground level.
3. Place joysticks in neutral.
4. Run engine at 1/2 speed (RPMs) without load for three to five minutes, then reduce to slow idle.
5. Place ignition switch in the OFF position.
6. Follow the previous instructions for raising and lowering the conveyor bed for procedures requiring access to the undercarriage and tracks.

Every 10 Hours or Daily Routine Maintenance

1. Clean off paving material and spray cleaning solvent or release agent on the wearplate, extensions, and any other area that has been in contact with the paving material. Cleaning should be performed while the paver is hot.

NOTICE If asphalt material is allowed to remain on the paver overnight, possible damage and increased maintenance costs can result upon start-up the next day. Poor housekeeping will increase maintenance costs.

WARNING NEVER spray cleaning solvent on hot surfaces as serious injury can result.

2. Raise conveyors and place safety prop into position. **(Page 5-4)** Clean any asphalt material off all flat surfaces. Remove any debris from screed and check for leaks.
3. Lubricate the required parts. **(Page 5-7)**
4. Check battery cables and connections.
5. Check coolant level. Fill if needed.
6. Check for loose, worn or damaged hoses, tubes clamps. Tighten, repair or replace promptly.
7. Keep the fuel tank full to prevent condensation. Always fill at the end of the day.
8. Check engine oil level. **(Page 5-13)**
9. Check hydraulic oil level. **(Page 5-16)**
10. Perform any other engine preventive maintenance described in the Engine Operator's Manual.

NOTE: In cold weather, keep conveyor flight chains properly oiled with cleaning solvent or release agent. This will prevent conveyor bars from sticking. Neglect could result in conveyor bar damage or drive chain failure.

Every 50 Hours or Weekly Routine Maintenance

1. Check air filter. **(Page 5-14)**
2. The FIRST 50 HOURS, change engine oil and filters, then every 250 hours thereafter. **(Page 5-13)**
3. Check all battery connections and remove any corrosion present.
4. Drain fuel water separator (if needed). **(Page 5-16)**
5. Check torque hub oil level. Refill if needed. **(Page 5-6)**
6. Lubricate grease fittings on the flight screw on both sides of the screed, the fitting on the depth screw, and the fittings on the flange bearings located on top of the extension screed. Grease nuts on extension screws. **(Page 5-7)**
7. Perform previous routine maintenance and any other engine preventive maintenance described in the Engine Operator's Manual.

Every 100 Hour or Monthly Maintenance

1. Check main engine belt. Adjust or replace if needed.
2. Check and adjust conveyor drive chains. **(Page 5-8)**
3. Check and adjust conveyor flight chains. **(Page 5-8)**
4. Check auger drive chains, lubricate and adjust. **(Page 5-9)**
5. Check and adjust screed extension top guide. **(Page 5-9)**
6. Perform previous routine maintenance and any other engine preventive maintenance described in the Engine Operator's Manual.

Every 250 Hours or Quarterly Routine Maintenance

1. Clean air filter. **(Page 5-14)**
2. Adjust engine belt. **(Page 5-14)**
3. Perform previous routine maintenance and any other engine preventive maintenance described in the Engine Operator's Manual.

Every 500 Hours or Semi-Annual Routine Maintenance

1. Replace coolant.
2. Change engine oil and filter. **(Page 5-13)**
3. Change torque hub oil.
4. Replace engine belt. **(Page 5-14)**
5. Replace fuel filter. **(Page 5-15)**
6. Clean fuel water separator. **(Page 5-16)**
7. Change the hydraulic oil and filter. **(Page 5-17)**
8. Perform previous routine maintenance and any other engine preventive maintenance described in the Engine Operator's Manual.

Every 1000 Hours or Annual Routine Maintenance

1. Drain hydraulic tank and replace strainer.
2. Replace air filter. **(Page 5-14)**
3. Perform previous routine maintenance and any other engine preventive maintenance described in the Engine Operator's Manual.

LUBRICATION

Torque Hub Lubrication

1. Remove the plug in the 3 o'clock position. **(Figure 5-5)**
2. If oil comes out, no oil is needed. Reinsert the plug and tighten.
3. If oil does not come out, remove the top plug and fill with SAE 90 WT gear oil until oil starts to appear at the 3 o'clock plug.
4. Replace both plugs and repeat process on the other torque hub.

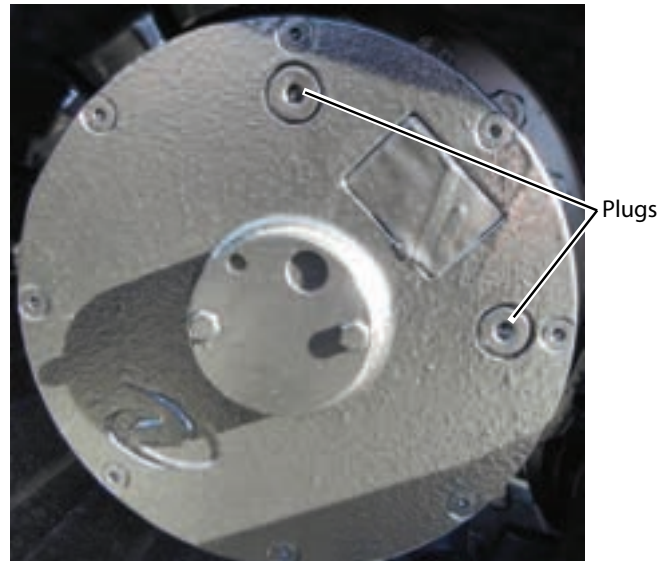

Figure 5-5. Torque Hub Plugs

NOTICE Changing oil and cleaning the paver should only be done in a designated area where the oil and chemicals can be contained. Discard these by-products in accordance with environmental regulations.

Lubrication Points

Proper lubrication is necessary to maintain the LeeBoy Model 8515E Conveyor Paver at top efficiency. Refer to the lubrication information below:

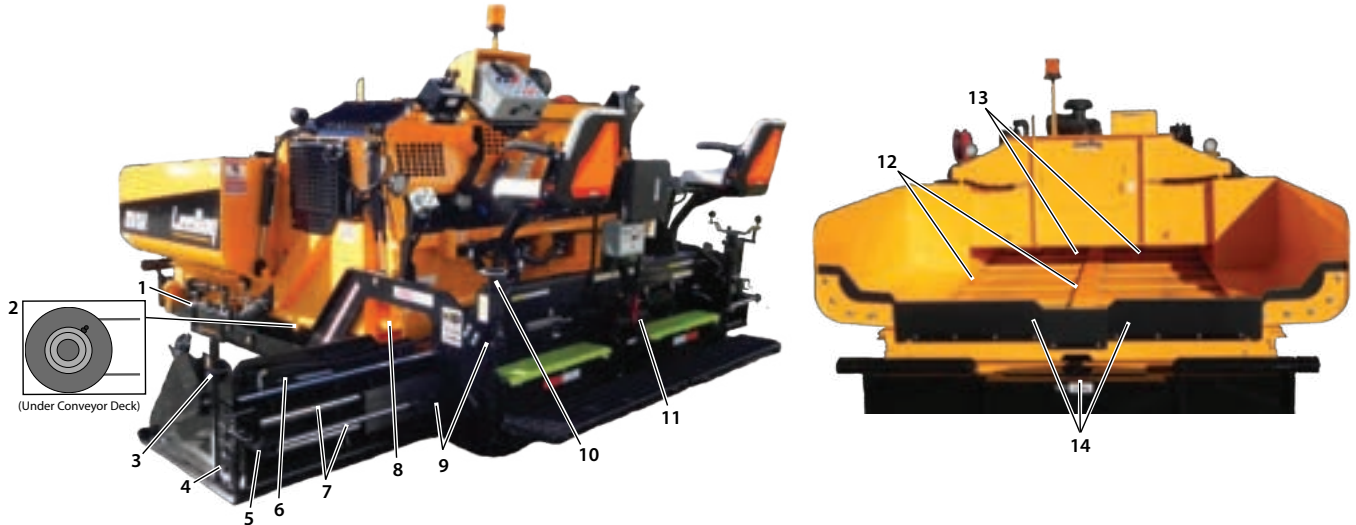

Table 5-1. Lubrication Points Schedule

5

ITEM NO.	TYPE LUBE	DESCRIPTION AND LOCATION	INTERVAL
	A	Grease With Shell Avania EP Grease 2 or Equivalent	
	B	Spray with Release or Chain Lube Agent	
	C	Spray with Anti-Seize Lubricant	
1	B	Grease tracks between track pads daily for efficient operation.	Daily
2	A	Conveyor pivot (under conveyor deck) on front of screed (both sides).	Monthly
3	A	Depth screw (both sides). Grease first in locked position, unlock, and turn 180° to grease.	Weekly
4	A	Screed pivot (both sides).	Weekly
5	A	Tilt screws (both sides).	Weekly
6	A	All screws and bearings on screed extensions (both sides).	Weekly
7	C	Screed extension slide bars (both sides).	Weekly
8	B	Auger bearings and end mount (both sides).	Daily
9	A	Flange bearing and fitting on flight screw and flange bearing on T-handle of extensions (both sides).	Weekly
10	A	Main flight screws ball socket and nut (both sides).	Weekly
11	B	Screed crown on chain.	Weekly
12	B	Conveyor chains (one on each side of each conveyor).	Daily
13	B	Auger (and auger chains).	Daily
14	B	Spray all parts of paver that come into contact with asphalt.	Daily

MAINTENANCE ADJUSTMENTS

Certain components of the paver need adjustments for optimum performance, operation and general maintenance.

WARNING Entanglement hazard! **DO NOT** run the engine while checking and servicing conveyor components. **NEVER** perform any adjustments while the engine is running.

Conveyor Flight Chains

The conveyor flight chains must be adjusted every 100 hours. If irregular movement of the conveyor occurs, an adjustment is needed regardless of the time interval. (See **Page 5-37** for slack tension adjustment.)

Flight bars along the conveyor flight chain are larger in the 8515E paver (one-inch) to assist in scraping off asphalt material for easier cleaning and maintenance.



Figure 5-6. Conveyor Flight Chain Adjustment

- 1 - Adjustment Bolt**
- 2 - Locking Nut**
- 3 - Hold-Down Nut**

There are four (4) adjustment bolts, two (2) for each conveyor. Use the following procedure to make this adjustment on both sides of the conveyor:

1. Raise conveyor bed and insert safety prop. (**Page 5-4**)
2. Loosen the hold-down nuts (one on each side of each adjustment bolt). (**Figure 5-6**)
3. Loosen each locking nut beside the adjustment bolt.

4. Turn each adjustment bolt alternately the same amount. For example, turn one bolt one half turn, then the other bolt one half turn, etc.
5. Continue alternating tightening until the flight chains are tight. (The pressure on the chain will be noticeable as the bolts are tightened.)
6. After the conveyor chain tension is set, retighten locknuts and bolts holding the flight chain assembly.

NOTE: If the adjustment bolt has reached its maximum adjustment level, remove two links in the conveyor chain and add a half link. This repair should bring the adjustment bolts back to full travel.

NOTICE Keep conveyor flight chain properly oiled with cleaning solvent or release agent during cold weather to keep conveyors functioning smoothly.

Conveyor Drive Chain

Keep chains clean, lubricated and properly adjusted. Inspect both drive chains at the rear track. (See **Page 5-37** for slack tension adjustment.) If the chains are loose, adjustment is necessary.

1. Shut off paver.
2. Open engine access door on the side to locate the conveyor drive chain bolts.
3. Loosen the jam nuts on the chain adjuster. (**Figure 5-7**)

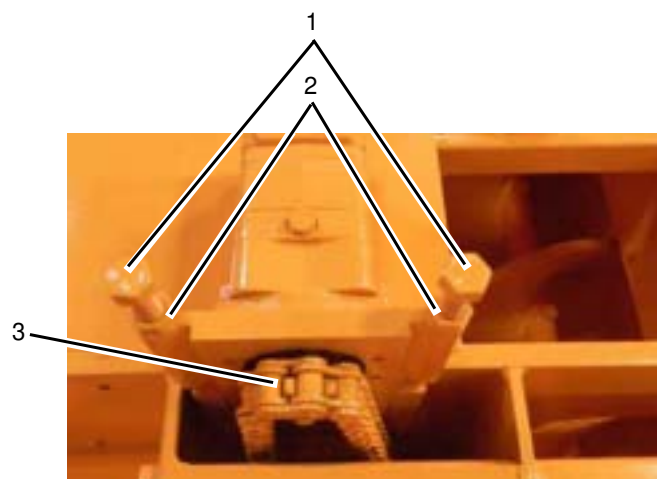

Figure 5-7. Conveyor Drive Chain Bolts

- 1 - Chain Adjuster**
- 2 - Jam Nuts**
- 3 - Conveyor Drive Chain**

4. Turn the chain adjuster to loosen or tighten the chain, leaving approximately 1/4-inch of slack. DO NOT overtighten.
5. Retighten jam nuts.
6. Repeat steps on the opposite conveyor drive chain.

Auger Drive Chain Adjustment

The auger chains should be snug, not loose. (See **Page 5-37** for slack tension adjustment.) If the chains need to be tightened, follow this procedure:

1. Raise conveyor bed and insert safety prop. (**Page 5-4**)
2. Loosen the motor bolts on the right and left auger chains. (**Figure 5-8**)
3. Loosen jam nuts and turn the tension adjusters counterclockwise to tighten chains.
4. Once adjusted, retighten motor bolts and jam nuts.

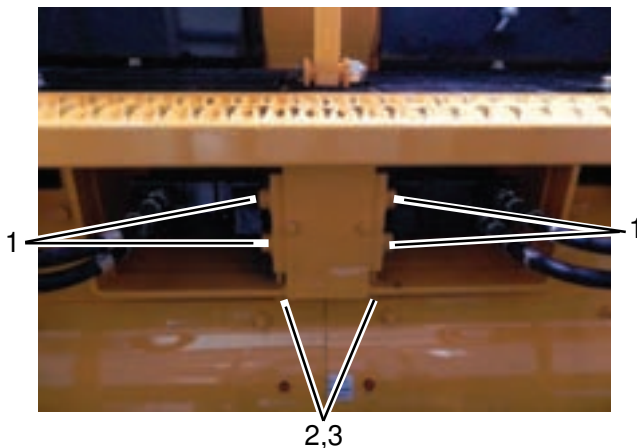

Figure 5-8. Auger Drive Chain Bolts

- 1 - Motor Bolts
- 2 - Jam Nuts
- 3 - Tension Adjuster

Screed Extension Top Guide Adjustment

1. Retract both screed extensions completely using the left and right extensions switches on the control panel. (**Pages 3-6 to 3-7**)
2. Loosen the top guide and hold-down bolts. (**Figure 5-9**)
3. Push guide down against the slide rail and tighten allen screws until snug, starting from the outside and working toward the center on each side of the slide rail.
4. Using a jack, raise extension up until it fits the bottom guide level.
5. Adjust top guide to allow for .008-inch clearance across top guide.
6. Grease slide with multipurpose grease.
7. Retighten the hold-down bolts, securing guides to specification.
8. Adjust allen screws until proper setting is achieved.
9. Tighten hold-down bolts to 90 ft. lbs.
10. Check operation and adjust if needed.

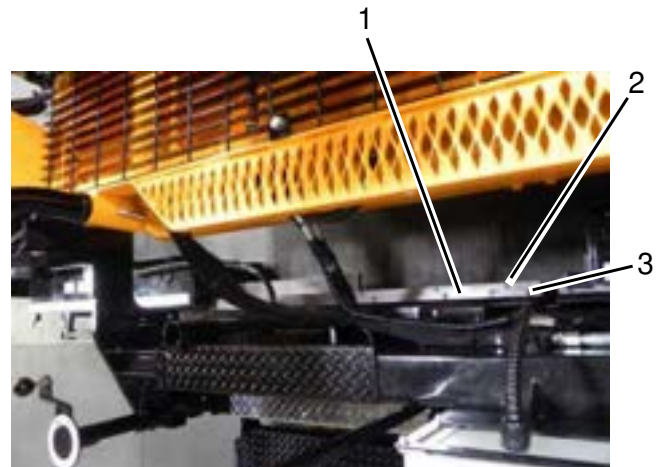

Figure 5-9. Screed Extension Top Guide Adjustment

- 1 - Screed Extension Top Guide
- 2 - Allen Screws
- 3 - Hold-Down Bolts

Track Tension Pressure Relief

The hydraulic adjustment cylinders are automatic and provide even tension on the tracks to prevent excessive wear to the paver's undercarriage. The track tension main manifold is mounted on the back side of the lower hydraulic tank in the conveyor bed.

The track hydraulic pressure is set at 1500 PSI at the track tension main manifold.

To check pressure, locate the track tension main manifold in the conveyor bed and perform the following procedures:

1. Raise conveyor bed. (Page 5-4)
2. Connect a 2000 PSI gauge in-line with either Port A or Port B on the track tension main manifold. (Figure 5-10)
3. Place a Porta Power between the front idler and frame to release pressure on the idler.
4. Increase the Porta Power pressure until the front idler cylinder compresses.
5. Pressure should read 1500 PSI.
6. If the pressure is not correct, remove cap on the relief cartridge valve. Using an allen wrench, adjust the relief cartridge valve IN for more pressure or OUT for less pressure until the PSI gauge reads 1500 PSI.
7. When the pressure gauge reads 1500 PSI, disconnect Porta Power and gauge.

NOTICE Do not tamper with the adjustment part of the relief cartridge valve.

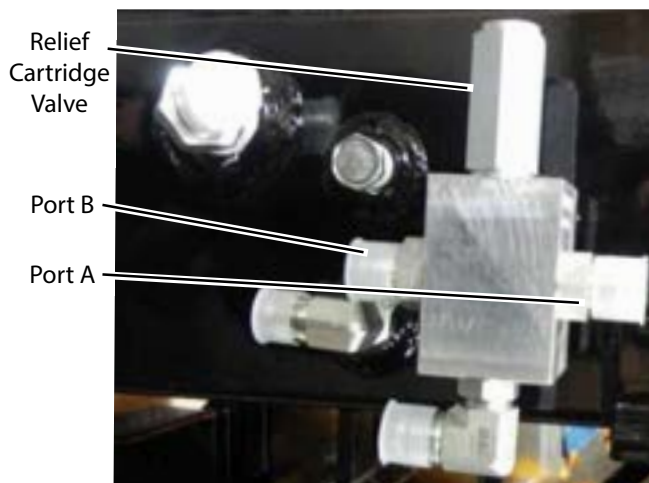

Figure 5-10. Track Tension Main Manifold

Conveyor Switch Adjustment

Small adjustments may be necessary to conveyor switch for optimum conveyor performance. (Figure 5-11) There are two positions of the conveyor flap: One upper, shutting the conveyor OFF; and one lower, turning the conveyor ON.

- When correctly adjusted, the conveyor shuts off when the paddle is approximately eight (8) inches (20.3 cm) from the top of the conveyor switch to the bottom of conveyor paddle; and turns on when the paddle drops to approximately 12 inches (30.5 cm).

OFF Position

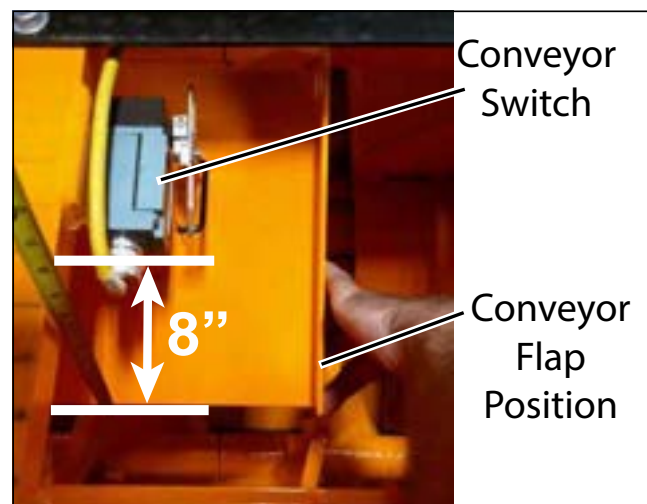

ON Position

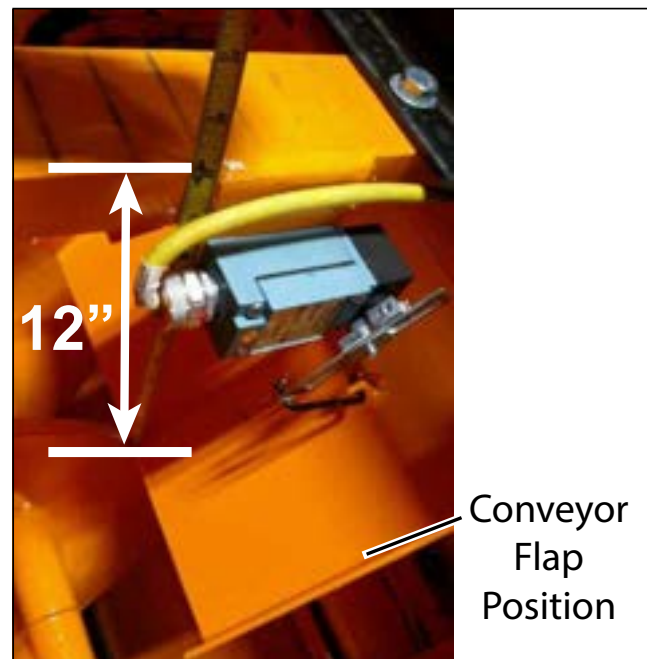

Figure 5-11. Adjustment Measurements

Check Adjustment

1. Remove the upper walkboard grate.
2. Raise the conveyor flap eight (8) inches (20.3 cm) from the bottom of the channel.
3. Secure conveyor flap so it remains in this position.
4. Check the conveyor switch.
5. If the switch clicked OFF, no further adjustment is required to the upper flap.

Adjust Conveyor Switches

If the conveyor switch did not click OFF, adjustment is needed:

1. Remove the linkage attaching the actuator arm to the eyelet on the flap pivot housing.
2. Loosen Setscrew A on the actuator arm. **(Figure 5-12)**
3. Reposition this arm by either rotating it clockwise or counterclockwise, depending upon where the conveyor switch clicked OFF during the conveyor flap upward travel.
4. When the switch clicks OFF, tighten setscrew and reconnect linkage.
5. Repeat procedure for the lower flap.

If the lower flap switch did not click OFF:

1. Loosen Setscrew B. **(Figure 5-12)**
2. Slide the actuator arm IN or OUT to bring the travel limits into tolerance.
3. This may require several adjustments before the correct position is obtained.
4. When the actuator arm is in the correct position,

tighten Setscrew B.

NOTE: The factory setting is one inch (2.54 cm) from the center of Setscrew B to the eyelet on the actuator arm.

NOTE: The setting from the factory is 1 in. (2.54 cm) from the center of the setscrew "B" to the eyelet on the actuator arm.

5. To bring the travel limits into tolerance, slide the actuator arm in the direction desired. This may require several adjustments before the correct position is obtained. When the actuator arm is in the correct position, tighten setscrew "B". No further adjustment is necessary.

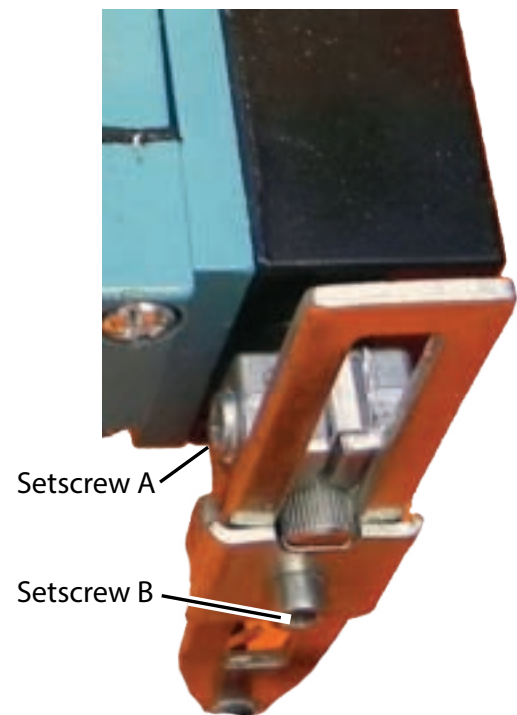

Figure 5-12. Actuator Arm - Setscrews A and B

Torque Hub Hydraulic Motor Gear Adjustments

NOTICE Torque hub hydraulic motors are calibrated and set at the factory. These adjustment should only be performed by an authorized LeeBoy dealer. Work not performed by an authorized dealer can damage machine and void the warranty.

The low gear adjustment must be made to the slow side drive motor only. The low gear adjustment screw is located on the bottom of the drive motor. Make only small adjustments at a time.

Your authorized LeeBoy dealer will perform the tracking adjustment on the high side gear by adjusting the screw on the top of the hydraulic motor. This adjustment on the motor must be screwed in to equalize track speed.

Your LeeBoy dealer will perform the following procedure to adjust either gear:

1. With paver running, push the 2-Speed switch.
2. Adjust screw (on bottom of the hydraulic motor for low gear; on top for high gear) until you feel back pressure on the adjustment screw. This indicates the correct adjustment is close.
3. Finalize adjustment by making a one-quarter (1/4) turn at a time until the correct adjustment is accomplished. Recheck tracking.

NOTE: If hydraulic motor has not been previously set, ten revolutions of the adjustment screw may be required before noticing any difference in travel.

ENGINE MAINTENANCE

The LeeBoy 8515E Conveyor Paver features the latest in engine technology. Tier 4 engines comply with emission requirements established by the U.S. Environmental Protection Agency (EPA) to reduce diesel particulate matter (DPM) and other toxins released into the air. As part of the Clean Air Rules of 2004, the EPA requires engine manufacturers to integrate controls into systems that reduce exhaust emissions by 90 percent.

Advanced emission-control devices and low-sulfur fuel requirements--only Ultra-Low Sulfur Diesel (ULSD) can be used in these engines--combine with new after-treatment methods such as Exhaust Gas Recirculation (EGR) and Diesel Particulate Filters (DPF). These general maintenance procedures are most often required for the engine. Refer to the Engine Operator's Manual for more specific maintenance information and procedures.

You can access the engine and other components via the access panel in the hopper (**Figure 5-13**) or via the operator platform. Some components can also be reached from either side of the machine.

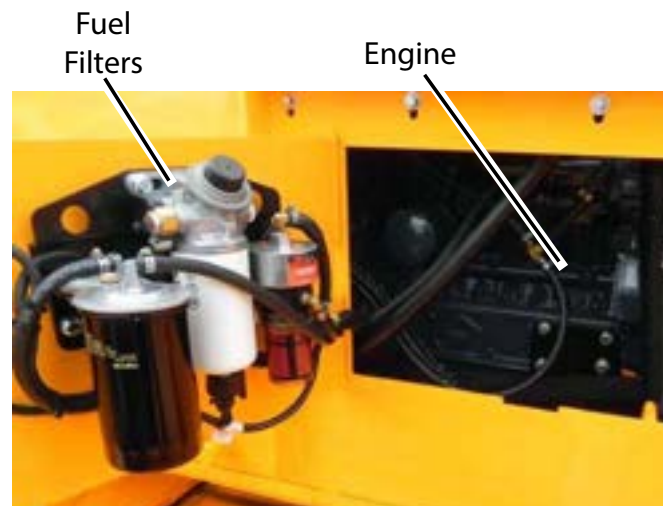

Figure 5-13. Engine Access Panel

Check Engine Lubrication Oil

The engine lubrication oil must be kept at a level above the ADD mark, but not above the FULL mark, on the engine lubrication oil dipstick. **(Figure 5-14)** Access the engine through the front engine access panel in the paver hopper.

WARNING DO NOT check the oil while the engine running. Hot oil can spew and cause serious personal injury.

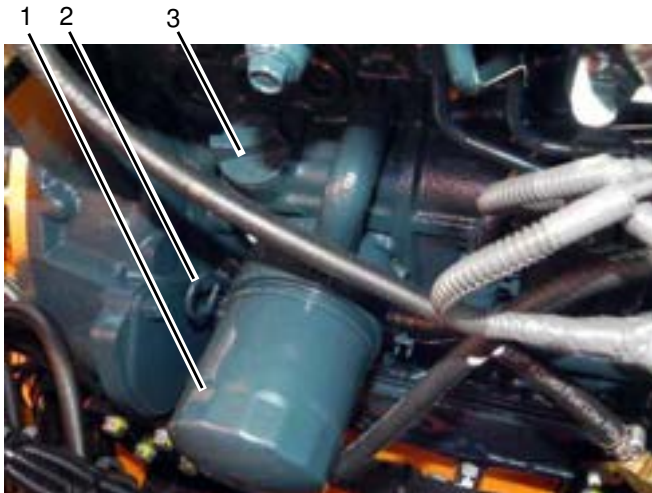

Figure 5-14. Engine Oil Dipstick and Oil Filter

- 1 - Oil Filter
- 2 - Oil Dipstick
- 3 - Oil Fill Cap

To check the engine lubrication oil level:

1. Park the machine on a level surface and turn off the engine.
2. Wait five minutes to allow the oil to return to the oil pan so you can obtain an accurate measurement of the engine oil level.
3. Clean the area around the engine oil dipstick before removing it from the engine.
4. Remove the dipstick from the engine and checking the oil level. The oil level should be above the ADD mark--but not above the FULL mark--on the dipstick.
5. Add oil if needed.

Change Engine Oil and Filter

The engine lubrication oil and oil filter must be changed at the same time. **(Figure 5-14)**

To change the engine lubrication oil:

1. Park the paver on a level surface and turn off the engine.

WARNING Change the engine lubrication oil while the engine is WARM, not hot. Hot oil can cause serious personal injury.

2. If needed, wait until the engine lubrication oil has cooled a little. Oil should be warm, not hot.
3. Locate oil drain hose on right side of the paver.
4. Place a container large enough to hold 15 quarts (14.2 liters) of oil underneath the drain hose.
5. Remove cap on end of the hose and drain all engine oil into the container.
6. Reinstall cap back onto the hose and reinsert hose back into place.
7. Fill the engine with 15 quarts (14.2 liters) of oil at the oil fill cap.
8. Check oil level using the oil dipstick.
9. Dispose of used oil in accordance with local and federal environmental laws.

NOTICE DO NOT change the engine lubrication oil filter while the engine is running. Serious engine damage will occur.

Use the following procedures to change the oil filter:

1. Wipe the area around the oil filter and its mounting base with a clean cloth.
2. Place the empty container under the filter element.
3. Use a filter removal wrench to remove the filter, turning counterclockwise.
4. Drain and discard the oil filter in accordance with Step 9 above, including the rubber gasket.
5. Wipe inside the oil filter head using a clean, lint-free cloth.
6. Rub a little oil on the rubber gasket area of the new filter element.
7. Fill the new filter with fresh oil.
8. Install the new filter element onto the filter head. Carefully tighten the filter (by hand only).

Change Air Filter

NOTICE Never operate the engine without an air filter properly installed. Severe damage to the machine will occur.



Figure 5-15. Air Filter Cover

To change the air filter elements:

1. Unclamp and remove air filter cover. **(Figure 5-15)**
2. Remove the primary and secondary air filter elements. Discard.
3. Clean the inside of the air cleaner body with a clean cloth.
4. Install new air filter elements inside the canister.
5. Reclamp cap onto the air filter cover.
6. Check clamps to ensure filter elements are tight and filter elements are making proper contact.
7. Start engine. If engine does not run smoothly, recheck filter element contact.

NOTE: The air filter elements should be replaced every 100 service hours of normal paver operation, but more often if the paver is operated in severe conditions.

Engine Drive Belt

Adjust the engine drive belt every 250 service hours and replace it every 500 hours. Regardless of the maintenance interval, the engine fan belt should be replaced if it appears frayed or cracked. This belt drives the alternator and the cooling fan.

NOTE: If the fan belt is loose or damaged, and/or the fan is damaged, it can result in overheating or insufficient charging. Replace the fan belt and any other damaged components immediately.

WARNING Engine must be turned off and the key removed before checking, adjusting or replacing the fan belt to avoid personal injury or even death.

To adjust or replace the belt:

1. Turn off engine and remove the key. Block the wheels to prevent movement while working on the machine.
2. Remove the safety shield. **(Figure 5-16)**
3. Apply moderate thumb pressure to the belt between the pulleys to gauge tension.
4. If tension is incorrect, loosen the alternator mounting bolts and place a lever between the alternator and the engine block.
 - If adjusting the belt, pull the alternator out until the deflection of the belt (when pressed in the middle of the span) falls within .39 to .47 inches (10 to 20 mm).
 - If replacing the belt, remove worn belt and replace with new fan belt.
5. Retighten the alternator bolts and reinstall safety shield.

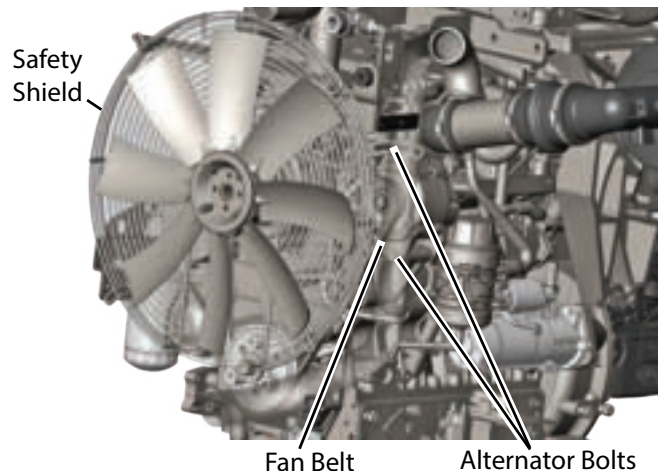

Figure 5-16. Engine Belt

FUEL SYSTEM

Fuel Tank

The fuel level is indicated on the digital display fuel gauge. Always fill the fuel tank at the end of the work day to prevent condensation. The green fuel cap is located on the right side of the paver in front of the spraydown hose reel.

NOTICE Fill up with low-sulfur diesel fuel at the end of the day to reduce condensation in the tank.

WARNING Diesel fuel is highly **FLAMMABLE**. **DO NOT** smoke while filling the fuel tank. Fill the fuel tank in a designated area that provides proper ventilation with a fire extinguisher available.

WARNING Explosion Hazard! Never fill the fuel tank near an open flame, or near equipment that can create sparks. Never check fuel level or fuel system components near an open flame.

WARNING Explosion Hazard! Stop the engine immediately if any fuel leakage is noted. **DO NOT** start the engine until the leak has been corrected.

To fill the fuel tank:

1. Stop engine.
2. Remove fuel cap from fuel tank.
3. Fill with diesel fuel until full.
4. Replace fuel cap.

Change Fuel Filter

The fuel filter, water separator and fuel pump with bowl filter are conveniently located together on the engine access door in the hopper. (Figure 5-17)

WARNING **DO NOT** change the fuel filter while the engine is running.

NOTICE The fuel filter is a 1-micron filter that can only be purchased from LeeBoy or Kubota.

NOTICE Tighten the fuel filter as directed on by the filter manufacturer. **DO NOT** overtighten the fuel filter element onto the filter head.



Figure 5-17. Fuel Filters

1 - Fuel Filter

2 - Fuel/Water Separator

3 - Fuel Pump with Bowl Filter

Replace the fuel filter using the following general procedure.

1. Stop the engine and allow it to cool.
2. Put a container under the filter before removing it.
3. Wipe the area around the fuel filter and mounting head using a clean, lint-free cloth.
4. Use a filter removal wrench to loosen and remove the filter by turning it clockwise.
5. Drain and discard the removed filter in compliance with local and federal environmental laws..
6. Wipe inside the filter head with a clean, lint-free cloth.
7. Fill the new fuel filter element with the diesel fuel.
8. Wipe a little fuel on the rubber gasket.
9. Install the new fuel filter element onto the filter head, carefully tightening the element by hand.
10. Start the engine and check for any fuel leaks.

Fuel Water Separator

Water and dirt that gets into fuel settles into the water separator. **(Figure 5-18)** As it collects, a red float rises. When the float reaches the line on the separator, an error code will appear on the PV480 digital display. It is important to drain it immediately.

NOTICE If you run out of fuel, it is important to pump the water separator to prime fuel injection lines. Failure to do so can adversely affect performance.

To drain the water separator:

1. Pull retainer clip from plug to disconnect the harness.
2. Unplug the harness, then unscrew the plug.
3. Drain and reinsert components.



Figure 5-18. Water Separator

- 1 - Pump
- 2 - Filter Body
- 3 - Plug
- 4 - Clip

To clean the water separator:

1. Follow the previous steps for draining the water separator.
2. Loosen and remove the filter body and clean it with light oil.
3. Reinsert and tighten.

HYDRAULIC SYSTEM

Check Hydraulic Oil

The hydraulic motors and hydraulic cylinders use the same hydraulic oil reservoir and hydraulic oil supply.

NOTICE Take care when working with the hydraulic system to ensure it is completely clean.

NOTICE Never allow the hydraulic oil level to fall too low. Pump damage will occur.

WARNING DO NOT use your hands on any hydraulic hoses, fittings or system component when checking for leaks. Serious personal injury can result from an oil leak under high pressure. Oil can be injected under the skin by high pressure. Protect the eyes by wearing safety glasses.

Check the hydraulic reservoir oil level daily using the sight gauge on the left side of the paver. **(Figure 5-19)**

Check the hydraulic oil level when the hydraulic oil is at normal operating temperature for an accurate reading.

If the hydraulic oil level falls below the bottom line (red or black in color), add more hydraulic oil.

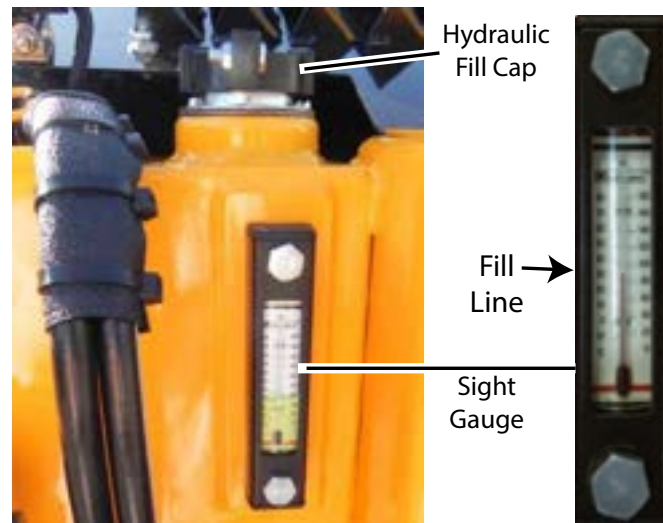

Figure 5-19. Hydraulic Oil Cap and Sight Gauge

WARNING DO NOT loosen or remove the hydraulic oil strainer fill cap when the hydraulic oil is hot. Always loosen the cap slowly to relieve any pressure in the hydraulic oil reservoir.

- DO NOT use unfiltered hydraulic oil.
- Check the hydraulic oil level using the sight gauge.
- Keep the hydraulic oil filled to the correct level.

NOTICE DO NOT overfill the hydraulic oil tank.

NOTICE Leeboy uses a lead-detection dye that may turn the hydraulic oil a slight yellow tint.

Change Hydraulic Oil and Filter

Changing the hydraulic oil removes the accumulation of dirt, water and mechanical wear particles from the hydraulic oil system. Clean, filtered oil is critical to optimize hydraulic system operation. The hydraulic oil system holds approximately 41 gallons.

NOTICE Contaminated hydraulic oil can shorten the expected service life of components in the hydraulic system.

WARNING DO NOT drain the hydraulic oil when it is hot. Hot hydraulic oil can cause serious personal injury.

WARNING Protect your eyes by wearing safety glasses when working on hydraulic system components.

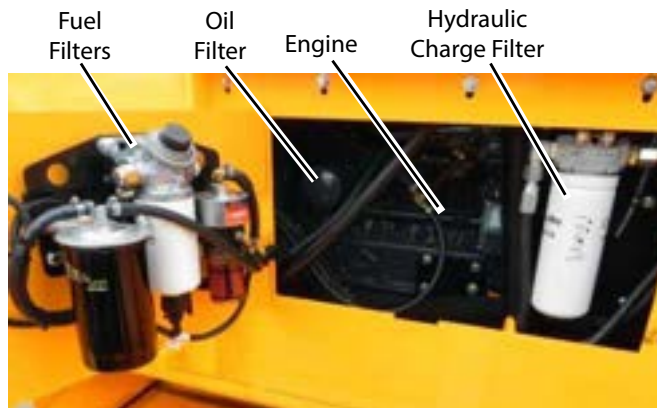

Figure 5-20. Hydraulic Charge Filter

Use the following procedures to change the hydraulic oil and charge filter:

1. Stop the engine.
2. Allow the hydraulic oil to cool until it is at a warm temperature.
3. Slowly remove the hydraulic oil strainer fill cap. Do not remove the strainer portion under the cap.
4. Place a clean, lint-free cloth over the reservoir fill tube opening and secure in place with tape.
5. Place a container sufficient to hold the hydraulic oil as it drains from the drain hose by the access panel on the right side of machine (close enough for the drain hose to reach).
6. Carefully remove the plugs from the hydraulic drain hose and open the valve over the container.
7. Allow all the hydraulic oil to drain from the hydraulic tank into the container.
8. Reinstall the hydraulic oil drain plug on the drain hose and tighten securely. Close valve.
9. Change the hydraulic oil filter by turning filter counterclockwise, then replace with new filter turning clockwise until snug (by hand only). **(Figure 5-20)**
10. Carefully remove the cloth from the hydraulic oil reservoir fill tube opening.
11. Remove the strainer. Replace if necessary.

NOTICE DO NOT fill the hydraulic oil reservoir with new hydraulic oil until the strainer inside the fill cap has been serviced.

12. Fill the hydraulic oil tank with filtered hydraulic oil. The cold oil level should be about 1/2-inch below the fill level black line on the sight gauge. **(Figure 5-20)**
13. Reinstall the hydraulic oil strainer filler cap and tighten the three wingnuts securely.
14. Start the engine and check the hydraulic system for possible leaks.

CAUTION Stop the engine immediately if any hydraulic leak is noted. DO NOT start the engine until any problem noted has been corrected.

ELECTRICAL SYSTEM

The electrical system is a 12-volt negative ground system. Connect the positive (+) cable to the positive (+) post of the battery. Connect the ground cable to the negative (-) post of the battery. It is advisable to disconnect the negative (-) cable first and connect it last. Reversed polarity can damage the electrical system. (Figure 5-21)

WARNING Fire and Explosion Hazard! Always observe battery polarity when connecting a battery charger or jumper cables to the battery: negative (-) to negative (-), positive (+) to positive (+). Failure to do so can produce sparks.

When connecting a booster battery, connect one end of the first jumper cable to the positive (+) terminal of the dead battery and the other end to the positive (+) terminal of the booster battery. Connect one end of the second jumper cable to the negative (-) terminal of the booster battery and the other end to the frame of the paver with the dead battery.

WARNING Fire and Explosion Hazard! Be sure that the battery charger is in the OFF position before connecting it to the battery.

Be sure to keep the battery fully charged during cold weather to keep it from freezing. Freezing weather has little effect on a fully-charged battery.

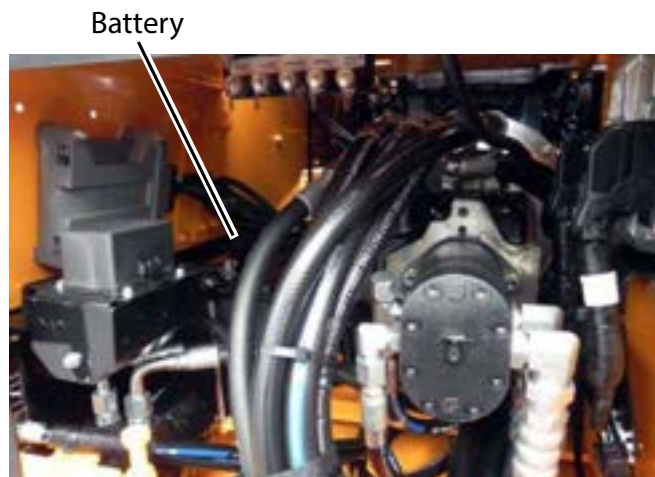

Figure 5-21. Battery Location

NOTICE ALWAYS turn the master battery switch off when working on the electrical system or welding anywhere on the machine. Damage to electrical components could result.

NOTICE DO NOT pressure-wash electrical components, especially around the generator. Protect electrical components when washing paver.

Battery Servicing

WARNING Batteries contain sulfuric acid. ALWAYS wear safety goggles and protective clothing when servicing the battery.

WARNING NEVER allow battery fluid to come into contact with clothing, skin or eyes. If battery fluid contacts the eyes or skin, immediately flush with clean water and obtain prompt medical treatment.

WARNING Keep sparks and flames away from the batteries as electrolyte gas is highly flammable.

1. Open cover on left side of the paver to access battery.

NOTE: When replacing the battery, discard the old battery properly.

2. Before connecting the batteries, turn off the master switch, located under the operator control panel. (Figure 5-22)



Figure 5-22. Battery Master Switch

3. Be certain that battery terminals and posts are clean and that the battery cable terminals are tight.

NOTICE Dirty or loose battery connections can create high electrical resistance and permit arcing.

4. If corrosion is present around terminal connections, remove and wash with ammonia or a solution of 1/4-pound (.11 kg) baking soda added to one quart of warm water. Ensure the vent caps are tight to prevent solution from entering the cells.
5. Pour clean water over the battery and surrounding area to rinse away the solution.
6. Check vent cap breather openings to ensure they are clear.

Alternator

The alternator supplies electrical power to electronic controls and charges the battery. Its built-in regulator controls voltage output. **(Figure 5-23)**

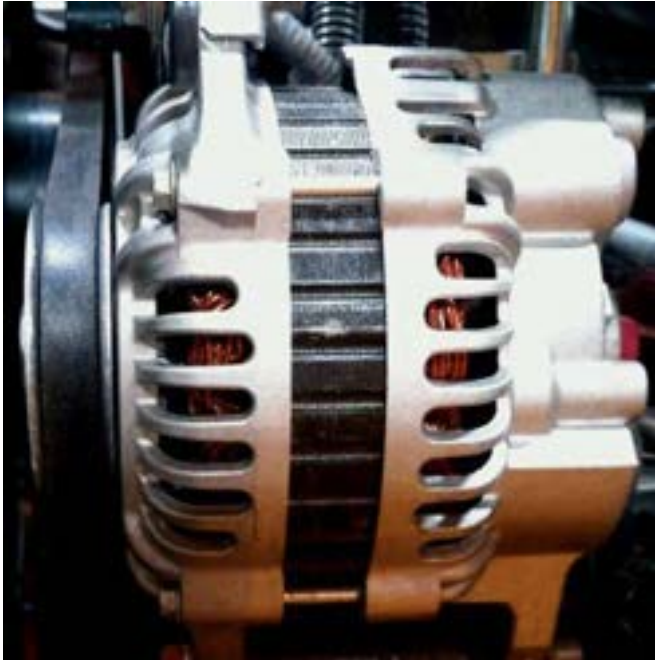

Figure 5-23. Alternator

Use the following precautions to prevent damage to the alternator or regulator:

- Never polarize the alternator.
- Never ground any alternator terminals or circuits.
- Always disconnect the battery before disconnecting or connecting the alternator.
- Never disconnect the alternator while machine is operating.
- Ensure wiring is properly connected before connecting the battery.
- Always connect a booster battery in the proper polarity: negative (-) to negative (-) and positive (+) to positive (+).

ELECTRIC HEAT CONTROL BOX

The electric heat control box contains the element breakers and main outputs for the screed heating system. Powered at 240 VAC, each element has two circuit breakers. **(Figure 5-24)** Refer to the electrical schematic in **Section 6** for detailed information.

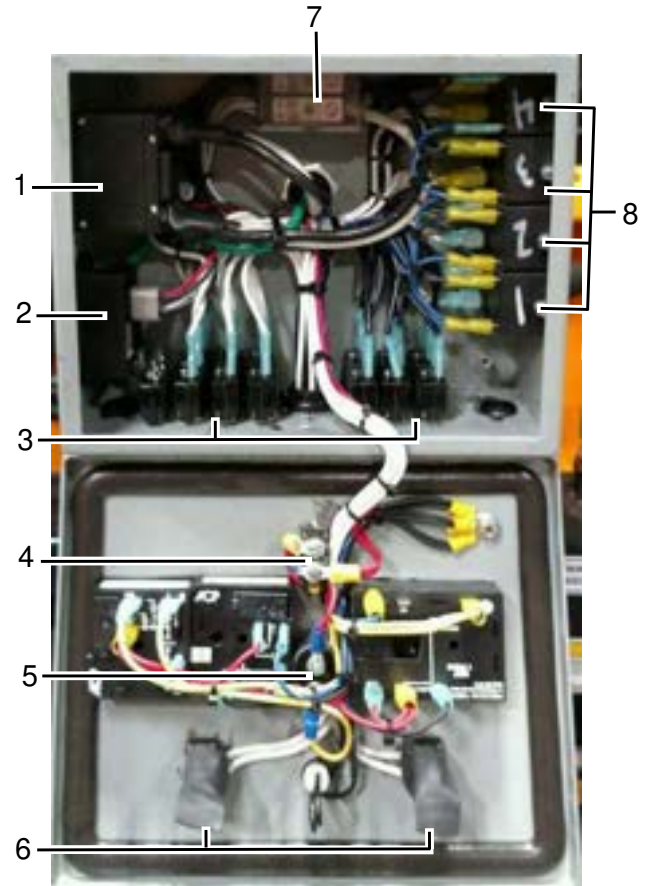

Figure 5-24. Electric Heat Elements

- 1 - Generator Circuit Breaker**
- 2 - Generator Speed Controller**
- 3 - Element Circuit Breakers**
- 4 - Power On Toggle**
- 5 - Heat On Button**
- 6 - Toggle for Left/Right Endgates**
- 7 - Wire Junction Block**
- 8 - Heating Element Relays**

Maintenance

The control box consists of the major components shown in **Figure 5-24**.

- The system timers, located on the control box cover.
- The element breakers are located in the lower surface of the box.
- The other block in the center is used as a wire junction block only.

NOTE: Control boxes are manufactured to fit all screed and paver combinations. If not all plugs are connected to wires, it may be normal. Be sure to keep unused plugs covered with mating protective caps.

- Each element output consists of two wires--one connects to the L-1 circuit and the other to the L-2 circuit. **(Figure 5-24)**
- Each breaker has two terminals--one is connected to the main input and the other terminal to an element output wire.
- The L-1 circuit is the left bank of element breakers.
- The L-2 circuit is the right bank of element breakers.

Heating element relays “make” or “break” the circuit to each element to start or stop the heating cycles. When the HEAT ON button is depressed, 12VDC is momentarily applied to the main timer relay to start the timing cycle.

Element Resistance Testing

The breakers are wired into each leg of each element. If an element has a fault, either in the wiring, or in the element itself, the breaker will trip and power will no longer be applied to that leg of the element.

When a breaker in the control box has “tripped,” there may be a problem in the wiring or an element in the circuit.

The breakers can be manually reset by depressing the trip button back into place when they are extended. If the breaker still does not reset, you need to test or possibly replace an element.

If the element is functioning correctly, you should read a resistance between the connector pins when testing. A faulty element will show high resistance, indicating a bad element. Refer to the following resistance table and element testing procedure:

Table 5-7. Element Resistance Table

Item	STD Legend Screed	HD815 Screed **
Generator Size (kW)	10 kW	10 kW
Breaker Size	50 Amp	50 Amp
Main Screed Elements (2)		
Wattage Per Element	1750 W	2000 W
Total Wattage	3500 W	4000 W
Resistance per Element	24.3 - 26.8 Ω	26 - 32 Ω
Screed Extension Elements (2)		
Wattage Per Element	1000 W	1000 W
Total Wattage	2000 W	2000 W
Resistance per Element	42.5 - 46.8 Ω	62.6 - 32 Ω
Heated Endgate Elements (2) **		
Wattage Per Element	N/A	500 W
Total Wattage	N/A	1000 W
Resistance per Element	N/A	88.5 - 108 Ω

**** Option item.**

To test the element:

1. Disconnect elements one at a time from the connection point on the lower side of the control box, keeping track of connector placement.
2. Using an ohm meter, test the resistance through the element between the two pins in the plug. **(Figure 5-25)**

NOTE: You do not have to test the plug attached to the lower side of the control box.

3. Before replugging the element, check each wire pin with an ohm meter test lead, placing the lead on a steel section of the screed frame. If there is any continuity through the element to the frame, the element must be replaced.

WARNING DO NOT operate an element with a known electrical shortage. Replace faulty elements and wiring immediately.



Figure 5-25. Plug

Heating Elements

Each heating element is sized to fit properly and provide sufficient heat to the screed plate. Elevated temperature prevents mix from sticking to the lower surface of the screed plate.

An element assembly consists of four main components:

- The element.
- The wire protector adapter.
- The wire protector.
- The two-pin wire plug at the end of the element protector.

Each element is covered by a thin strip of insulation to keep heat from escaping. A support bar and shield protects the element assembly.

Each element is clamped onto the screed plate to provide a positive and efficient connection. Enough pressure should be applied to the element assembly to sufficiently hold it securely against the screed plate surface.

To remove an element:

1. Remove top cover from the extension screed plate.
2. Loosen all the clamping studs over the element.
3. Remove and replace element.
4. After tightening the clamping stud, lock the clamp by tightening the stud jam nut.

Generator

Voltage Testing

The generator is hydraulically-driven and runs continuously during operation to keep it cooled when the load drops. When the hydraulic system is at normal operating temperature and the engine is running at maximum RPMs, the generator produces 240 VAC.

The generator voltage depends upon speed (RPMs), increasing voltage as RPMs increase and decreasing voltage as RPMs decrease. The voltage will decrease significantly if the engine speed is slower than 1800 RPMs.

NOTE: When testing the generator voltage ensure the paver engine is at 1800 - 2200 RPMs, and the hydraulic temperature is at normal operating levels.

Test the generator voltage at the generator and at the control box using the following procedure:

1. Use a volt meter to measure between the two main input wires L-1 (black wire) and L-2 (white wire) at the generator. **(Figure 5-26)** If you measure from L-1 to the frame of the paver, or ground, the voltage will be half the rated output of the generator.
2. Using the volt meter, measure between the black and white input wires inside the control box on the terminal block. The voltage should be the same as what you measured at the generator.

If the voltage is lower, make certain the generator is turning the correct speed by testing with a Hz meter or photo tachometer. If the voltage is still low, contact your authorized LeeBoy dealer for generator speed tuning (see next section).



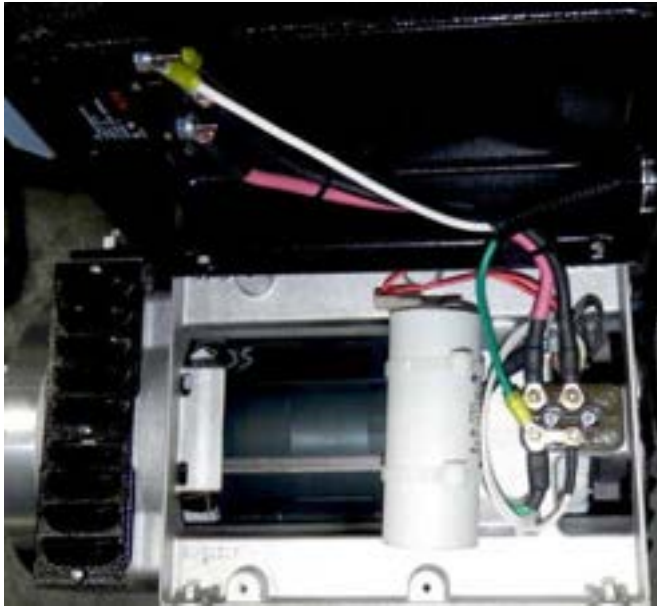

Figure 5-26. Generator

Generator Speed Check

NOTICE The generator should never be operated at a speed of 3800 RPMs or greater.

A voltmeter set to read frequency (Hz) can be used to test generator speed. When the engine is running at 1800 - 2200 RPMs, the generator should operate at 60 Hz. Make certain that the paver engine is running at 1800 - 2200 RPMs and the hydraulic temperature is at normal operating levels.

Generator Capacitor

The generator capacitor controls and regulates voltage while the machine operates. If the capacitor fails, the voltage will drop below normal or no output at all. It is located under the generator cover.

If experiencing a drop in voltage, replacing the capacitor will help determine if the capacitor is at fault.

To perform this procedure:

1. Shut down the machine.
2. Detach the wires on top of the capacitor.
3. Remove the capacitor and replace with new one.
4. Reattach wires.

Dielectric Grease

Dielectric grease is a nonconductive, insulating compound applied to electrical connectors. When applied correctly, a high-quality dielectric grease displaces debris and moisture in the connector. The proper application of dielectric grease fills any gaps between pins or in the connector which prevents debris and moisture from creating corrosion of the electrical components.

CAUTION Equipment damage can occur if using low-quality, incompatible dielectric grease.

If not applied or incorrectly applied, corrosion can result that causes rapid increase in resistance, intermittent connections, overheating, and a variety of electrical problems. Numerous electrical issues throughout the machine can be avoided by the proper application and use of dielectric grease.



Figure 5-27. Correct Application of Dielectric Grease

To correctly apply dielectric grease:

- Apply a thin, visible, uniform coat using **ONLY** high-quality dielectric grease (Dow Corning 4 or equivalent) across the **MALE** connector.
 - Coating too thin may not fill the gaps between pins.
 - Coating too thick may prevent proper connection or force pins or seals out.
- Plug in the male connector.

CAUTION DO NOT force connector to lock if too much grease has been applied.

CAUTION Excessive grease application does not allow a proper connection by preventing the plugs from locking into place, and can cause damage to the connector seals.



Figure 5-28. Incorrect Application of Dielectric Grease

REPLACEMENT PROCEDURES

Front Idler

Follow this procedure for replacing the front idler (**Figure 5-29**):

1. Raise conveyor and insert safety prop. (**Page 5-6**)
2. Locate track tensions manifold and back the relief cartridge out of the aluminum block about three turns until you hear the tension pressure release.

NOTE: Perform this additional step for poly or steel tracks only: Rotate the track so the master pin is at the rear bottom of the front idler and back up the paver until the track clears the front idler.

3. Jack up the paver at least two feet (61 cm) off the ground for enough clearance under the undercarriage to perform this procedure.

DANGER Crush hazard! Always use safety blocks in addition to jack when working under the paver to prevent serious injury or even death.

4. Remove the clip pin from the cylinder rod and idler bracket. Idler will slide out.
5. Remove the idler bracket and bolt to the new idler.
6. Install idler, ensuring cylinder and clip pin are aligned properly.
7. Lower sprocket back down toward the track chain, ensuring the sprocket is about one (1) inch (2.54 cm) from the chain.

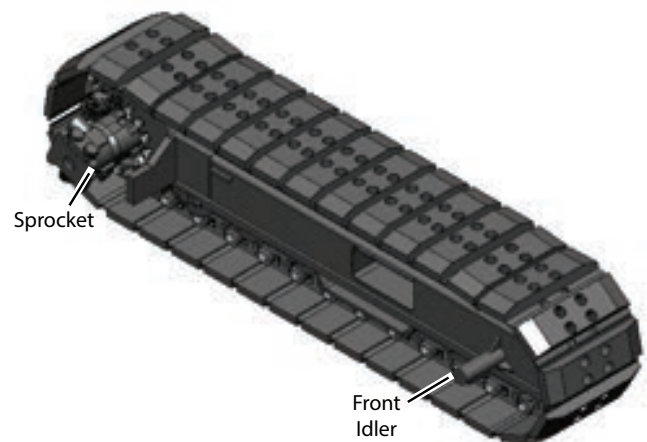

Figure 5-29. Front Idler

5

Perform these additional steps for poly or steel tracks only:

8. Check that the track chain is full seated with the drive sprocket and rollers are aligned with chain center.
9. Tighten the tension relief.
10. Lower paver to ground, remove jack and start machine. Track tensions will automatically adjust when the machine is started.
11. Ensure the track chain remains fully seated with the drive sprocket and rollers still aligned with the chain center.

Track Tension Cylinder

1. Follow **Steps 1 - 4** in the previous section. The track tension cylinder is located behind the front idler. **(Figure 5-29)**
2. Pull the track tension cylinder toward the front to remove the hose from the bottom of the cylinder.
3. Repack the seal kit or replace cylinder if worn, and reinstall.
4. Install idler, ensuring cylinder and clip pin are aligned properly.

NOTE: If equipped with poly or steel tracks, follow Steps 8 - 11 above.

Track Rollers

1. Raise conveyor and insert safety prop. **(Page 5-6)**
2. Release track tension by screwing the relief cartridge out of the manifold (about three turns or until you hear the pressure release).
3. Jack up the paver at least two feet (61 cm) off the ground for enough clearance under the undercarriage to perform this procedure.

⚠ DANGER **Crush hazard! Always use safety blocks in addition to jack when working under the paver to prevent serious injury or even death.**

4. Remove the faulty rollers and replace with new ones.
5. Torque bolts to 90 ft lbs (122 N•m).
6. Ensure the track chain is fully seated with the drive sprocket and rollers are aligned with chain center.
7. Tighten tension relief.
8. Lower paver to the ground and start machine. Track tension will automatically adjust when machine is started.
9. Ensure the track chain remains fully seated with drive sprocket and rollers aligned with the chain center.

Track Sprocket (Steel or Poly)

1. Raise conveyor and insert safety prop. **(Page 5-6)**
2. Rotate the track master pin to the bottom of the sprocket.
3. Release track tension by screwing the relief cartridge out of the manifold (about three turns or until you hear the pressure release).
4. Remove track master pin at bottom rear of sprocket. Drive paver forward to disconnect track from the top of the sprocket.
5. Jack up the paver until the sprocket clears the track.

⚠ DANGER **Crush hazard! Always use safety blocks in addition to jack when working under the paver to prevent serious injury or even death.**

6. Remove bolts holding sprocket. **(Figure 5-29)**
7. Remove rear track roller.
8. Slide sprocket off and replace.

9. Slide sprocket back in place.
10. Place thread-locking adhesive on bolts and install bolts holding sprocket.
11. Lower paver so that sprocket goes back into track chain. Drive paver forward to rotate track onto top of the sprocket.
12. Place master pin back in track and place thread-locking adhesive on bolts.
13. Tighten relief cartridge in the manifold.

Rubber Track (Option)

1. Raise conveyor and insert safety prop. **(Page 5-6)**
2. Jack up the paver at least two feet (61 cm) off the ground for enough clearance under the undercarriage to perform this procedure.

⚠ DANGER Crush hazard! Always use safety blocks in addition to jack when working under the paver to prevent serious injury or even death.

3. Loosen the track tension cartridge at the manifold located at rear of the bottom hydraulic tank.
4. Label and disconnect the track tensions hoses from undercarriage at track tension manifold.
5. Cap and plug all hoses.

NOTE: Remove generator cord at generator if removing left undercarriage (electric heat screed only).

6. Remove the two (2) bolts holding the drive motor to the torque hub. **(Page 5-31)** Support the undercarriage with a forklift or jack before lowering to the ground.
7. Unbolt the two (2) trunnions on the front of track undercarriage and stops at each side of the rear of the undercarriage.
8. Lower the track assembly.
9. Remove rubber track by prying from the idler end first.
10. If needed, replace idler, torque hub, sprocket, rollers and/or cylinder. Lower the undercarriage for replacing above components, except rollers.

Torque Hub

If the torque hub has been damaged or worn, use the following procedures for replacement:

1. Raise conveyor and insert safety prop. **(Page 5-6)**
2. Loosen the track tension valve on the track tension manifold to release pressure.
3. Remove master pin in the track chain behind the front idler (bottom side).
4. Back paver up until track lays flat on the ground.
5. Jack up the paver at least two feet (61 cm) off the ground for enough clearance under the undercarriage and place on sturdy jack stands.
6. Remove the two cap screws and lock washers attaching the drive motor to the torque hub drive.

NOTE: DO NOT disconnect hoses from the hydraulic drive motor. Hoses are long enough to slide the motor out. Clean hoses before reinstalling.

NOTE: Mark location of torque hub to the undercarriage before removing to ensure the drive motor is reinstalled in the same position.

NOTE: Sprocket can be removed before the torque hub by removing the rear track roller and bolts in the sprocket.

7. Remove bolts holding torque hub to track undercarriage. **(Figure 5-30)**

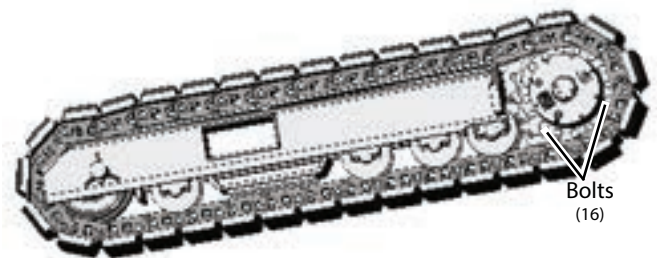

Figure 5-30. Torque Hub

8. Install torque hub in proper position to align with the drive motor.
9. Place thread-locking adhesive on torque hub bolts and torque bolts (see Torque Specifications in **Section 2**).
10. Check O-Ring on the drive motor and replace if worn.
11. Place thread-locking adhesive on sprocket bolts and torque bolts (see Torque Specifications in **Section 2**.)
12. Reinstall rear track roller if previously removed.
13. Fill torque hub with oil. (**Page 5-7**)
14. Lower paver to ground and reconnect track.

NOTE: Removing pad from chain where master pin is placed will make reconnecting track easier from top side at rear of the idler.

15. Retighten track tension valve.
16. Lower conveyor and bolt hopper wings.
17. Start paver and check for any leaks with engine running.

WARNING Stop the engine immediately if any hydraulic leak is noted. DO NOT start the engine until the leak has been repaired.

Two-Speed Hydraulic Motors

1. Move paver onto a ramp where you can access the undercarriage.
2. Disconnect, label and plug fittings on hydraulic hoses to the hydraulic motors. (**Figure 5-31**)

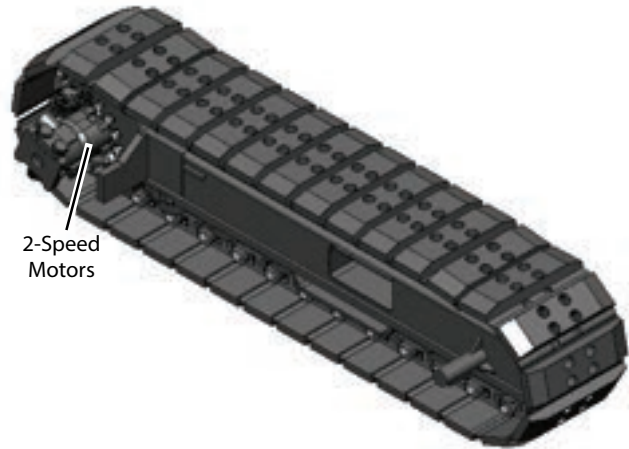

Figure 5-31. Two-Speed Hydraulic Motors

3. Place blocks sufficient to support the hydraulic motors underneath them.
4. Remove the two screws and lock washers attaching the hydraulic motor to the torque hub and carefully separate motor from the torque hub.
5. Remove the O-Ring and drain hydraulic oil from the motor. Discard or repair the motor as appropriate.
6. Lubricate a new O-ring with hydraulic oil and install onto the torque hub.
7. Reattach new or rebuilt hydraulic motor to torque hub and torque screws to 120 ft. lbs. (163 N•m)
8. Reconnect hydraulic hoses.
9. Start the engine and let machine idle for 10 minutes to work air out of the hydraulic system.
10. Check for any leaks.

Gear Pumps

Hydraulic fluid is transmitted throughout the machine to motors and cylinders, becoming pressurized according to the resistance present. The fluid is controlled by valves and distributed through hoses and tubes. Three gear pumps play a significant role in producing hydraulic power as it supplies hydraulic fluid to system components: The tandem gear, tandem drive, and auxiliary gear pumps. **(Figure 5-32)**

The tandem gear and tandem drive pumps are accessed via the left access panel. The tandem gear pump is attached to the tandem drive pump (just behind it). Both are easily reached via the left access panel. The auxiliary gear pump is easier to access from the front access panel inside the hopper.

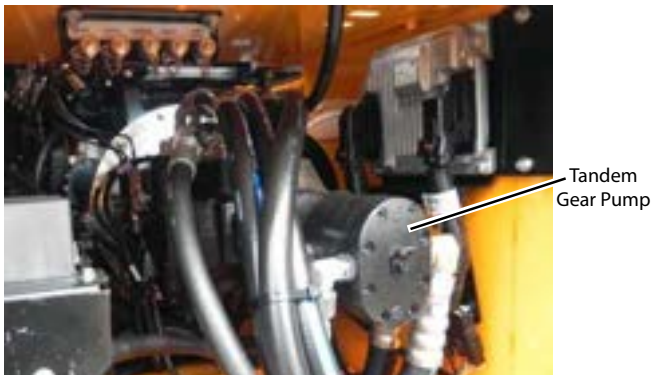

Figure 5-32. Tandem Gear Pump

Use the following procedure for replacing either of the gear pumps:

1. Access the gear pump slated for replacement.
2. Label and disconnect the hoses to the gear pump, capping the fitting on the pump.
3. Label, plug and cap the hoses.
4. Remove the two screws on the pump mount (one on each side of mount).
5. Lift the pump assembly out of the machine and place on a flat surface.
6. Remove and inspect the O-ring(s) on end of the pump for wear or damage. Replace if needed.
7. Put a small amount of hydraulic oil onto the O-Ring and reinstall.
8. Align the 2 mounting holes with the mounting on the pump.
9. Reattach with the two mounting screws and torque to 89 ft. lbs. (12 N•).
10. Remove plug caps and reconnect hydraulic hoses to pump as previously labeled.
11. Check hydraulic oil level. Add more if needed.
12. Start the paver and check to be sure there are no hydraulic oil leaks.
13. Let machine idle approximately 10 minutes to allow the pump and motor cases to fill with hydraulic oil.

Rear Conveyor Shaft, Bearings and Sprockets

1. Drive paver onto a ramp to access undercarriage.
2. Remove conveyor chain cover. **(Figure 5-33)**
3. Loosen chain tension adjuster bolts.
4. Rotate main conveyor chains away from the assembly.
5. Remove chain from the drive motor to the conveyor sprocket.
6. Remove bolt and washers holding the sprocket.
7. Remove the sprocket and bearing from the frame.
8. Remove bolts on the inner sprocket.
9. Slide out shaft and outer conveyor sprocket through frame side.

NOTE: Rear tube can be removed for changing the inner bearings.

NOTE: Remove the inner seals from replaced bearings in the tubes to allow grease to enter into the bearing area.

10. Place conveyor shaft into the inner conveyor sprocket.
 11. Insert bolt into shaft.
- NOTE:** The outer conveyor sprocket must be aligned with the inner sprocket.
12. Rotate the outer sprocket on the shaft until properly aligned.
 13. Reinstall the outer bearing and outer sprocket.
 14. Place thread-locking adhesive on the bolt and torque to 180 ft. lbs. (244 N.m).
 15. Reinstall the conveyor and drive chains and adjust.
 16. Grease bearings in the tubes by using grease blocks on each side below the hopper wing.

Conveyor Drive Motors

1. Disconnect hydraulic hoses from conveyor motor.
2. Remove four bolts holding hydraulic motor to slide mount. **(Figure 5-33)**
3. Slide drive motor out of slide mount.
4. Slide new or repaired drive motor into slide mount.
5. Secure with four bolts.
6. Reconnect hydraulic hoses to motor.
7. Check for leaks.

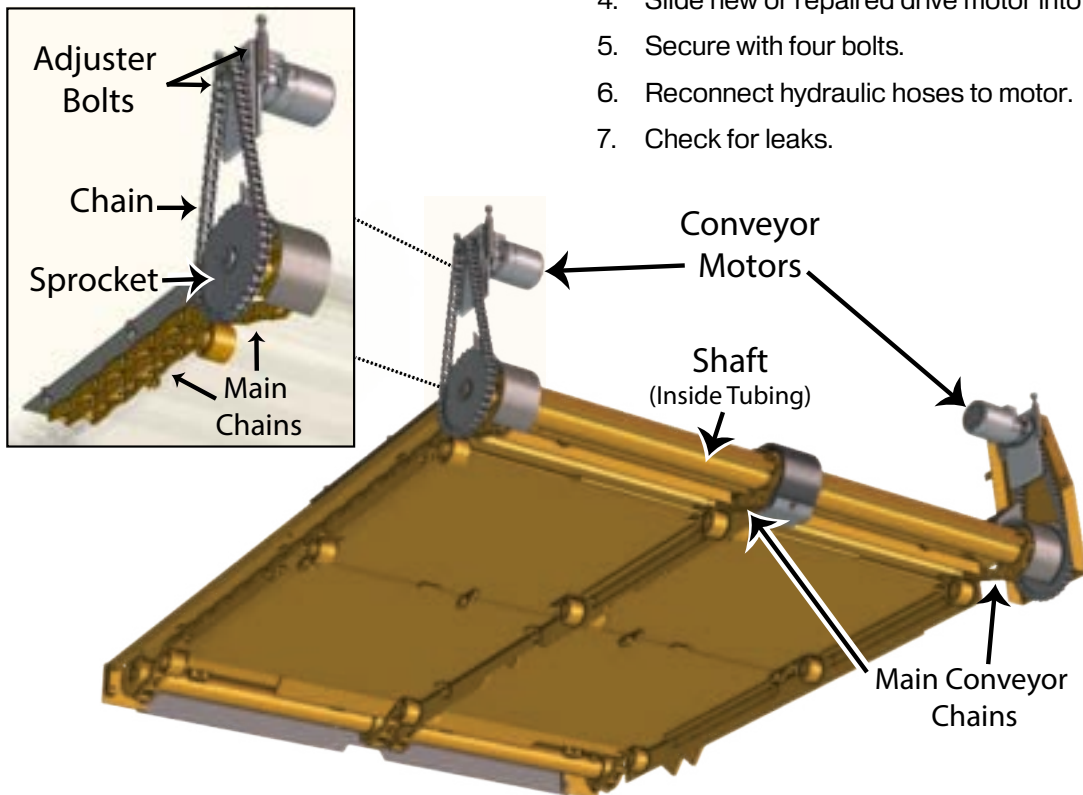

Figure 5-33. Conveyor Components

Auger and Inner Bearings

1. Extend the screed extensions completely and open the Under Auger Material Cutoffs.
2. Remove grating on the operator platform above the auger assembly and clean any asphalt build-up.

NOTE: Heating asphalt may be required for cleaning.

3. Remove the two (2) nuts holding top cover on and pry cover apart. **(Figure 5-34)**

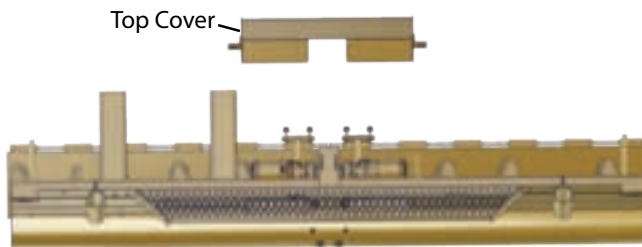

Figure 5-34. Remove Top Cover (Top View)

4. Remove lower auger bearing cover, then remove auger clamps on each side. **(Figure 5-35)**

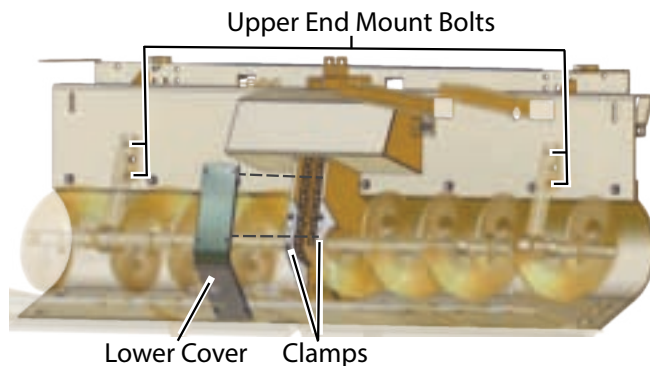

Figure 5-35. Lower Cover and Clamps (Top View)

5. Remove rear auger cover. **(Figure 5-36)**

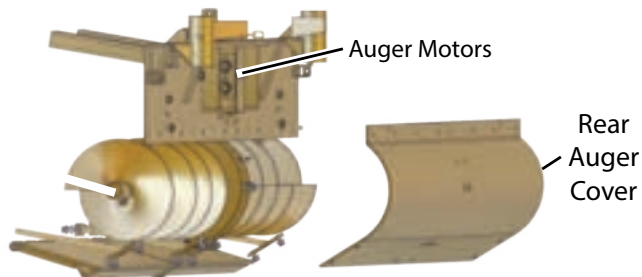

Figure 5-36. Rear Auger Cover (Side View)

6. Loosen the two (2) bolts on each auger motor mounting bracket, then loosen the two (2) drive chain tensioners. **(Figure 5-37)** The auger motors should slide down as you loosen the tensioners (tap with a rubber mallet if needed).

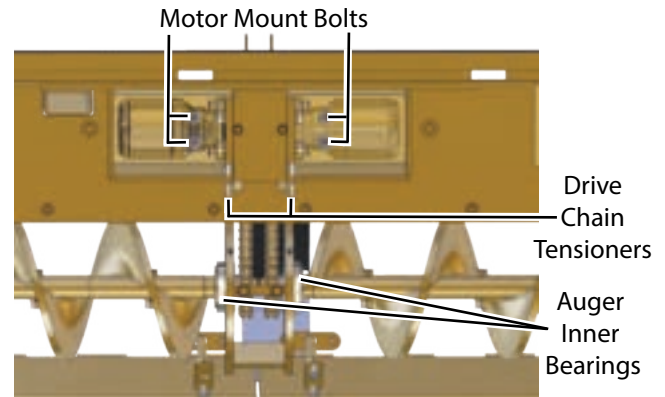

Figure 5-37. Auger Inner Bearings

7. Remove the upper end-mount bolts. **(Figure 5-36)**
8. Slide auger straight out and onto the ground, placing in the same position. *This is important as it is very easy to install new augers backwards!*
9. Check inner auger bearings. Replace if faulty. **(Figure 5-37)**
10. Align new augers the same as removed augers, ensuring they are on correct side to auger material outward.
11. Reinstall the upper end-mount bolts and torque to 78 ft. lbs. (106 N•m).
12. Feed auger chains back onto the sprocket, ensuring chains have approximately 1/4" (.635 cm) of slack. Adjust the auger motors up by tightening the drive chain tensioners, then tighten the motor mount bolts,
13. Torque motor mount bolts to 150 ft. lbs. (155 N•m) and lubricate chains.
14. Reinstall grating.
15. Operate augers to ensure proper function.

NOTE: Auger chains can be lubricated each day by spraying oil or chain lube through the slots where auger motor is adjusted.

Auger End Mounts

1. Extend the screed extensions completely and open the Under Auger Material Cutoffs. (You can remove the rear auger cover if you like, but it isn't necessary.)
2. Remove the outermost auger section. (**Figure 5-38**)

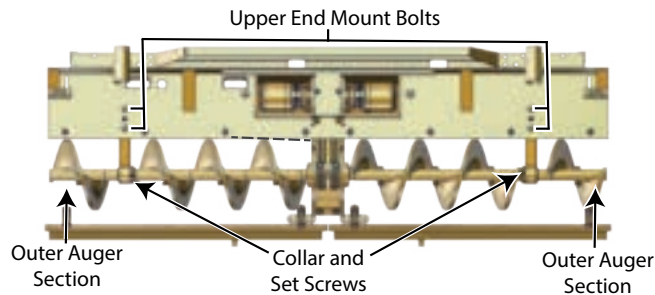

Figure 5-38. Outer Auger and Upper End Mounts

3. Remove upper end mount bolts.
4. Loosen the two set screws on the auger end mount collar, then slide the end mount and collar off the auger shaft.
5. Replace with new end mount, retighten set screws, reinstall outer auger section and upper end mount bolts (and rear cover if applicable).

Auger Motors

1. Extend screed extension completely.
2. Remove floor grating.
3. Clean asphalt buildup around cover.
4. Disconnect and label the hydraulic hoses. Plug fittings.
5. Remove the two nuts on the cover and pry the cover apart. (**Figure 5-39**)

NOTE: Heating asphalt may be required.

6. Loosen auger tension adjusters.
7. Loosen the two bolts securing the auger motor mounting brackets.
8. Loosen the auger chains by sliding the auger motors out from backside.

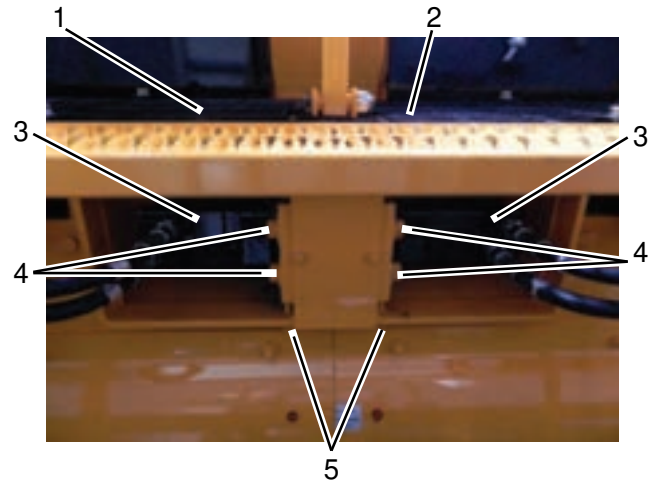

Figure 5-39. Auger Motors

- 1 - Floor Grating
- 2 - Front Auger Cover
- 3 - Auger Motors
- 4 - Auger Mounting Bolts
- 5 - Auger Tension Adjusters
9. Slide the long screw through the bolt side of the chain to prevent it from falling down into the cover. Once chain is secure, remove the bolt holding the sprocket.
10. Hold the sprocket at the chain as you slide out the motor.
11. Remove the sprocket from the chain.
12. Slide off the sprocket and remove the auger motor mount.
13. Place the new auger motor onto the mount.
14. Reinsert the sprocket back onto the chain.
15. Reinsert the motor.
16. Cover bolts with thread-locking adhesive, reinsert and tighten.
17. Adjust the chain for 1/4 inches of slack.
18. Lubricate with chain lube.
19. Reconnect the hydraulic hoses and check for leaks.

Main Screed Wear Plate

The screed wear plates can wear out over time and must be replaced if the plate has worn to less than 1/4-inch thick. Poor maintenance, paver cleaning, asphalt mixes containing hard aggregate and improper material flow can contribute to excessive wear on the main screed and extension wear plates. Correct screed heating also helps prevent excessive material build-up. An uneven, worn screed plate will produce an inferior mat

1. Retract screed extension completely.
2. Unbolt and remove the rear walk boards. **(Figure 5-40)**
3. Unbolt and remove upper and lower screed covers.
4. Remove bolts on the heating element covers and remove. Disconnect wiring.

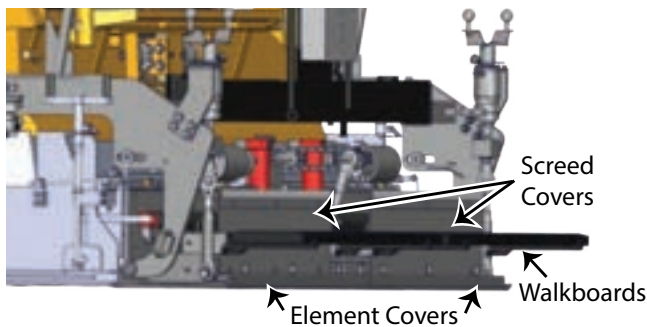

Figure 5-40. Walk Boards and Covers

5. Grasp handle and slide out inner screed element covers as shown in **Figure 5-41** to access wear plate bolts.

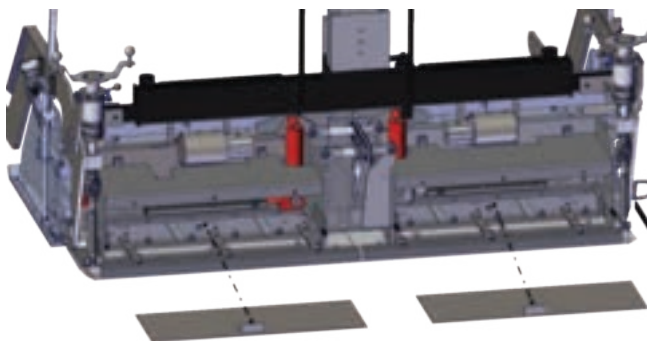

Figure 5-41. Inner Screed Element Covers

6. Remove both rows of bolts holding the wear plate to the bottom of the screed. **(Figure 5-42)**

NOTE: Clamp the center portion of the screed frame to hold the frame in place before lifting it from the worn wear plate.

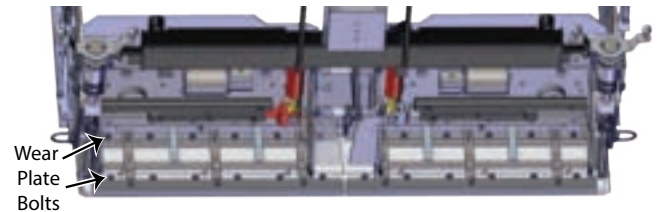

Figure 5-42. Wear Plate Bolts

7. Raise the screed completely.
8. Slide the worn wear plate from under the screed.
9. Clean all material buildup on the screed frame.
10. Set new wear plate level on three blocks, placing one block in the center and one at each end.
11. Lower the screed frame down onto the new wear plate.
12. Install center and side bolts first (front and rear) to hold the new wear plate in place, then install remaining bolts. **DO NOT tighten the bolts until all bolts are installed.**
13. Loosen the plate on the slotted side to adjust the crown. This will move the screed frame in and out on the wear plate to help align the bolts on the opposite side.
14. Install the remainder of the front bolts, then install the rear bolts, ensuring the screed frame and wear plate are flat.
15. Torque bolts to 55 ft lbs (74 N•m) starting inside, then moving outward, by rotating from the left to the right side to keep the screed relaxed.
16. Reinstall the screed covers in reverse order, then the walk boards.

Screed Extension Wear Plate

1. Extend the screed completely.
2. Remove the endgate by removing the tilt screw and nut on each side of the tilt screw. The endgate will tilt forward and slide off the bolt.
3. Disconnect the extension AOA adjuster (**Figure 5-43**) on top of the wear plate by removing locknut, washer and shoulder bolt.
4. Remove the three bolts holding the front extension hinge shield.

NOTE: If equipped with electric screed heat option, remove all wiring and heating elements.

5. Carefully slide the hinge pin out. The wear plate will disconnect and fall to the ground.
6. Hold the new wear plate in place and slide the hinge pin back into place.
7. Fasten the AOA adjuster back to the wear plate with locknut, washer and shoulder bolt.

NOTE: Reinstall all wiring and heating elements if equipped with electric screed heat option.

8. Reinstall the front hinge shield.
9. Reinstall the endgate and tilt screw.

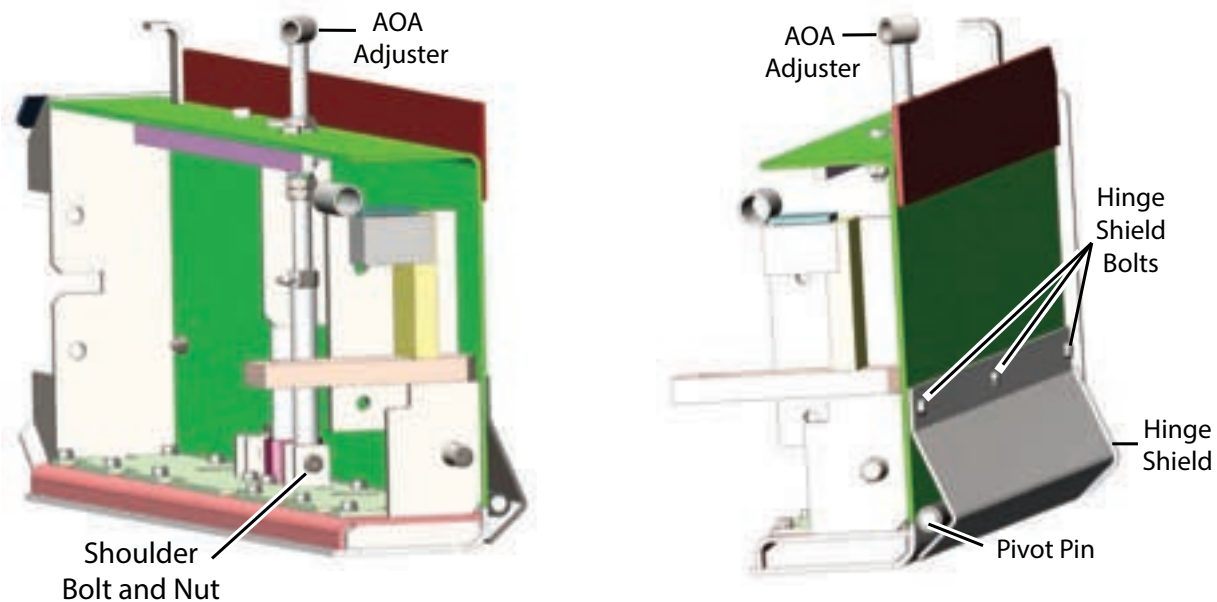

Figure 5-43. Wear Plate Replacement

Conveyor Switch Replacement

If you need to replace the conveyor switches, follow these instructions, using the color codes for wiring (**Figure 5-44**) to ensure the conveyor switches on the conveyor flap are wired correctly:

1. Raise the conveyor flap 6-1/2 to 7 inches (16.5 to 17.8 cm) from the bottom of the tank mount support.
2. With the switch installed and the conveyor paddle hanging down:
 - Using a multimeter, measure the ohms across the black and white wires.
 - Using a multimeter, measure the ohms across the red and green wires.

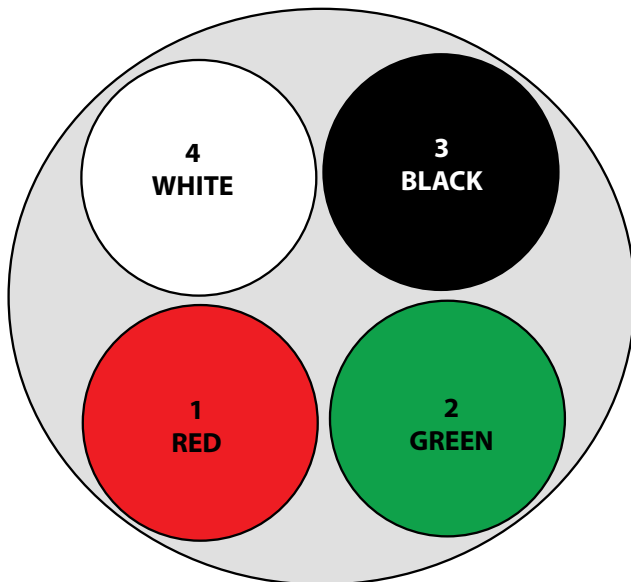

Figure 5-44. Conveyor Switch Wiring

3. Wire the switch using the wires that show continuity.
4. Repeat Steps 2 - 3 for the second switch.

NOTE: The switches are sealed and potted, therefore, they are not serviceable.

Replace Radiator Hoses

Radiator hoses should be replaced if worn or frayed. (See **Section 7, Illustrated Parts List (IPL)** for hose and component replacement part numbers.) Access the radiator from the top access panel.

WARNING This procedure should only be performed when the machine is not running.

WARNING DO NOT remove the radiator cap while the engine is still hot. The radiator is under pressure serious injury can occur if removed while hot.

1. Turn off ignition, remove key, and allow the engine to cool down.
2. Carefully remove the radiator surge tank cap. (**Figure 5-45**)

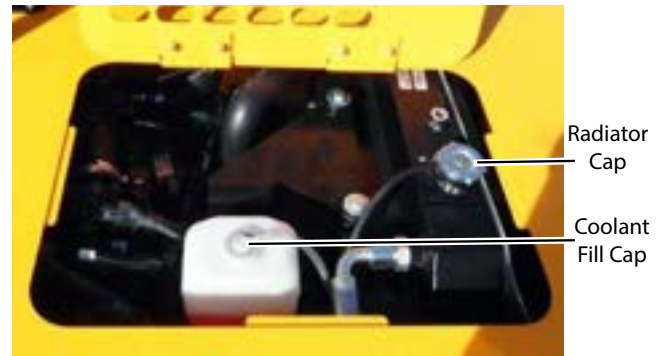

Figure 5-45. Radiator and Coolant Fluid Caps

3. Remove plug under the radiator tank and drain radiator fluid into a container large enough to hold 5.5 gallons (20.8 liters).
4. Remove the upper and lower hoses by loosening the hose clamps on each.
5. Disconnect hoses and inspect for damage.
 - If clamps are not damaged, retain for reinstallation (or replace if damaged).
6. Install new hoses and reconnect with hose clamps.

5

WELDMENT



Figure 5-46. Welding

If the machine has been damaged or metal parts worn due to extensive use, minor welding may be necessary for repair. Welding is very dangerous. Only individuals who are properly trained should weld in a dedicated area away from others as even looking at ultraviolet light from the flame can cause serious eye injury.

Welding hazards include toxic fumes, harmful dust, light radiation, burns, combustion from sparks and the potential for extensive damage to the eye. There is also a danger of electric shock. If combustible or flammable materials are nearby, the heat and sparks produced by welding can cause fires or explosions.

TURN THE BATTERY SWITCH OFF AND DISCONNECT BATTERY TERMINALS BEFORE WELDING ON THE MACHINE.

Electrical current can ignite fire or cause an explosion, therefore it is critical to turn off power to the machine. It is also important to grind off the paint to ensure proper ground on the area being welded.

DO NOT MAKE MODIFICATIONS TO THE MACHINE. ONLY weld if needed for repair purposes. Weldment modifications to the machine can void your warranty.

Before welding on the machine:

PREPARE:

- Clear the area of any fire hazards, flammable liquids and solids, or any items that could catch on fire.
- Ensure a fire extinguisher is available in the work area.
- Hang welding blanket(s) around and underneath the work area.
- Paint and rust should be removed from the welding area to prevent arcing in other areas or components. An indirect ground can cause arcing that will damage machine components. Only connect the ground to the component being welded. **DO NOT** connect the ground to other bolted assemblies, wheels, bearings, motors, tracks, torque hubs, etc.

DISCONNECT:

- Turn the master battery switch to the OFF position.
- Disconnect the battery positive and negative terminals.
- Disconnect Plus 1 controller(s).
- Disconnect engine ECU(s) controller (if equipped).
- Disconnect engine DEF controller (if equipped).
- If machine has truck chassis: Disconnect the battery positive and negative terminals and unplug the ECU(s) for the engine, transmission and ABS systems if equipped. Refer to the truck owner manual for any other recommendations.

WINTERIZING FOR STORAGE

Perform the following procedures to prepare the machine for winterizing and storage.

1. Store the machine in a dry, protected area:
 - Cover seat with plastic. Place a “DO NOT OPERATE” tag on the main control panel.
 - Cover all exposed control panels with tarps or plastic.
 - Ensure all cab doors and windows are closed and seal properly.
 - Ensure the tires are properly inflated.
 - Replace worn or damaged decals if needed.
2. Inspect the machine thoroughly and repair worn or damaged parts. Inspect all hoses, couplers, fittings and cylinders. Tighten loose fittings and replace any worn hoses found.
3. Lubricate all grease points:
 - Coat all exposed cylinder shafts with lithium-based grease.
 - Ensure all exposed threads are lubricated.
 - Ensure cables are lubricated and move freely.
 - If the machine has high- and low-speed chains, be sure they are oiled.
4. Check air filter. Clean or replace air filter elements if needed.
5. Check engine oil level and fill if needed.
6. Check hydraulic oil sight gauge and fill if needed.

NOTICE Hydraulic oil that is contaminated must be drained, the filter elements replaced and the hydraulic tank refilled. Failure to perform this maintenance procedure if needed could result in premature failure of the pumps or motors.
7. Ensure the fuel tank is full to prevent condensation in the fuel tank. Add cold-weather additive when appropriate.
8. If machine is equipped with Diesel Exhaust Fluid (DEF), ensure the DEF tank is full.
9. If machine is equipped with a citrus tank, ensure the tank is full to prevent rust.
10. If machine is equipped with water tank(s), the tank should be drained. The pump and filter must also be purged to prevent freezing.
11. If machine is equipped with windshield washer bottle, ensure the bottle is full of window washer fluid with a cold-weather blend.
12. Perform specific gravity test on engine coolant. Drain and replace or fill with antifreeze mixture to prevent freeze damage if needed.
13. Disconnect battery and store inside in a cool, dry place. Ensure breakers are in the OFF position.
14. Remove steering control boxes and electrical cords. Store inside in a cool, dry place.
 - If equipped with any plugged-in remote sensors (i.e., sonic auger sensor), disconnect, remove and store inside in a cool dry place.
15. Cover the exhaust and intake filter. Be sure to seal the exhaust cover with tape to prevent moisture from entering, especially if storing outside.
16. If the machine is equipped with a propane system, remove the propane gas bottle and store in a safe area away from the machine. Purge the gas system and seal connection(s).
17. Lower machine components and attachments (i.e., screed, broom, blade, etc.) to the lowest position, resting on blocks to prevent ground contact or pavement damage.
18. Clean the machine, including the undercarriage. Paint chipped or rusty areas to prevent further rusting. Lock all lockable panels, cab doors and spare tire. Remove ignition key and store keys in a safe place.



TROUBLESHOOTING

Spraydown Pump

The following troubleshooting information is provided in the event of any issues with the spraydown pump (located under a panel on the right side operator platform above battery master switch). **(Figure 5-47)**



Figure 5-47. Spraydown Pump Location

An electronic pressure sensor displays solid or flashing LED lights on top of the pressure switch for pump status notifications. **(Figure 5-48)**

Green:

- Solid green means the pump is spraying.
- Flashing green means the pump is in a stand-by mode, ready to spray.

Yellow:

- Solid yellow means the pump is priming.

Yellow/Blue:

- Flashing yellow and blue means the pump has incorrect voltage.

Red/Blue:

- Flashing red and blue means the pump has timed-out without fluid. Cycle pump power to reset.

Red:

- Solid or flashing red light means there is an error. Consult owner's manual for troubleshooting.

NOTE: If an overload occurs, the pump stops and a yellow-green LED will flash. The electronic system will try to reactivate the pump at preset intervals.

If the overload reaches a dangerous level, the red LED will become solid and you must switch the power off and start the pump again.

NOTE: When starting the spraydown pump or emptying the tank, open the bleeder valve slightly to expel air and facilitate priming. As soon as the pump is operating, close the bleeder valve.

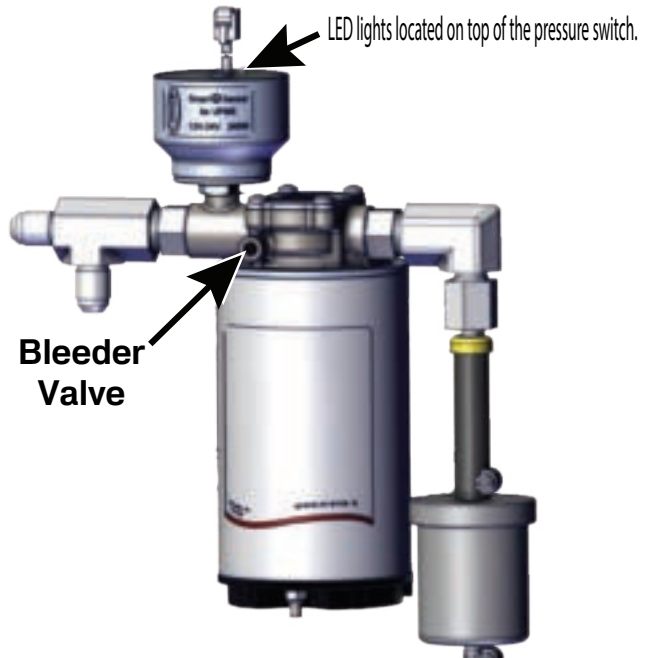

Figure 5-48. Spraydown Pump

If the spraydown pump has stopped or will not start:

1. Check the effectiveness of the battery power supply (voltage activity).
2. Check that the fuse has not blown.
3. Check for any foreign material present in the hose.
4. Avoid running the pump dry for more than a few minutes. (Pumps run dry by the absence of fluid are not covered by warranty.)
5. If the pump does not prime itself:
 - Raise the screed completely, ensuring citrus tank on the screed is filled.
 - Loosen the bleeder valve inside of the cut-out until the pump primes.
 - Retighten the bleeder valve.

Hydraulic Motor Installation Start-Up Procedure

Pre-Start

If the hydraulic system is down as a result of a major component failure:

1. Drain and clean the tank and system components (hoses, valves, fittings and cooler) to ensure it is free from metallic debris and other contamination. Failure to do so may result in damage to the pump(s) and/or other components on start-up.
2. Change all the filters.
3. Change the fluid. On large systems where the cost of changing the fluid may be prohibitive, the fluid should be flushed until a cleanliness level of ISO 4406 18/13 or better is achieved.

Installation and Start-Up

When installing hydraulic motors, it is important that the mounting flange of the motor makes full contact with the mounting surface of the application. (Figure 5-48) Mounting hardware of the appropriate grade and size must be used:

1. Use Grade 8 socket-head capscrews to attach the motor.
2. Install lock washer over capscrew.
3. Apply Loctite 243 (blue) to the capscrew threads.
4. Install extra thick, hardened H-D thick washers over the capscrew.
5. Install the capscrew-hardened washer and lock washer in the SAE two-bolt flange.
6. Torque the capscrew to the wet torque value defined for the capscrew grade and size.

NOTICE

It is CRITICAL to use the correct mounting hardware.

Hubs, pulleys, sprockets and couplings must be properly aligned to avoid inducing excessive thrust or radial loads. Although the output device must fit the shaft tightly, a hammer should never be used to install any type of output device onto the shaft. The port plugs should only be removed from the motor when the system connections are ready to be made.

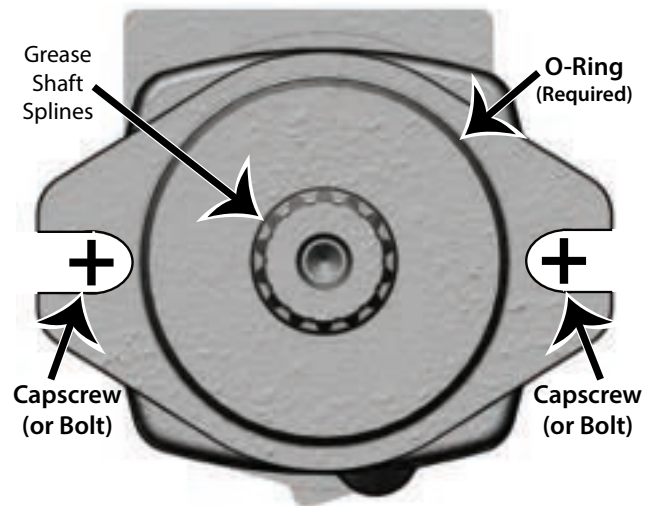

Figure 5-49. Hydraulic Motor Mount

To avoid contamination:

- Remove all matter from around the ports of the motor and the threads of fittings.
- Fill the case of the motor being used (piston-type, gear motor, gerotor motor, geroller motor or vane motor) with clean hydraulic fluid through the highest case drain port and connect the case drain line. Failure to do so will result in damage to the motor through inadequate lubrication on start-up.
- Units that are mounted vertically with the shaft up require special attention to ensure the fluid level in the case is high enough to lubricate the front shaft bearing(s).

Once all system connections are made, the motor should be run for 15 - 30 minutes at no-load and half-speed to bleed air from the hydraulic system.

Hydraulic Test Ports

The hydraulic test ports provide an easy and convenient means of checking pressure for the five main functions of the paver: Forward propel (left and right sides), conveyors/cylinders, augers/vibrators and the generator. **(Figure 5-50)**

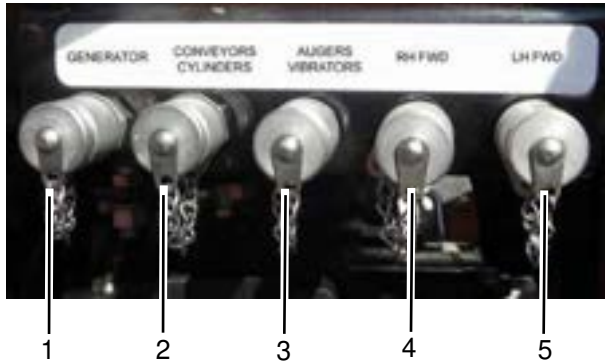

Figure 5-50. Test Port

Item No.	Function	PSI Relief / Gauge
1	Generator	Relief set at 3000 PSI. Use 4000 PSI gauge.
2	Conveyors/ Cylinders	Relief set at 3400 PSI. Use 4000 PSI gauge.
3	Augers/ Vibrators	Relief set at 3400 PSI. Use 4000 PSI gauge.
4	Right Forward	Relief set at 3625 PSI. Use 4000 PSI gauge.
5	Left Forward	Relief set at 3625 PSI. Use 4000 PSI gauge.

To check pressure:

1. Using the table above, connect the appropriate gauge to the port being tested.
2. Start the engine, then check gauge for the proper pressure reading.
3. If adjustment is needed, locate the pressure-reducing valve on left side of main manifold.
4. Remove valve cap with an allen wrench.
5. Adjust the pressure-reducing valve clockwise for more tension or counterclockwise for less tension.

Auger and Conveyor Chain Tension Adjustment

The auger and conveyor chains need periodic adjustment. Generally, the slack of a roller chain should be on the lower side. **(Figure 5-51)**

Adequate slack (S) is about four (4) percent of the span for normal drives, but the slack should be about two (2) percent of the span for the auger chains:

- Vertical drive or close to vertical drive.
- Center distance between two shafts is greater than three (3) feet.
- Chain is operated under heavy load and high frequency of on and off drive.
- Direction of the drive is often changed.

NOTICE Auger and conveyor chains must have a slack of 1/4 to 3/8 inches. To measure deflection, exert 40 - 60 pounds of force to chain in either direction.

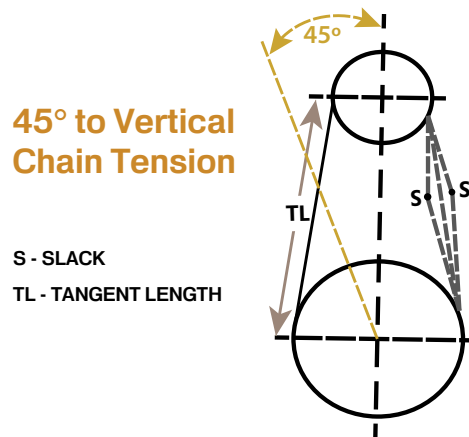

Horizontal to 45° Chain Tension

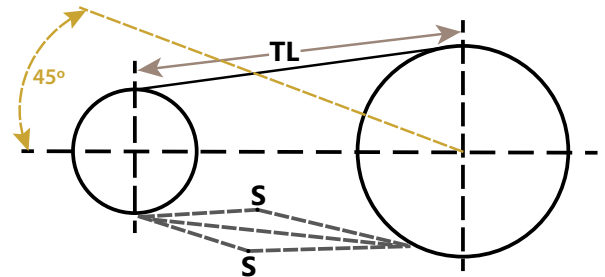

Figure 5-51. Chain Slack Adjustment for Proper Tension

REQUIRED MID-SPAN MOVEMENT

	Tangent Length (TL) Between Sprockets in Inches (Centimeters)					
	10 (25)	20 (51)	30 (76)	50 (127)	70 (178)	100 (254)
Tangent Length Between Sprockets in Inches (Millimeters)						
Horizontal To 45°	0.4 - 0.6 (10 - 15)	0.8 - 1.2 (20 - 30)	1.2 - 1.8 (30 - 46)	2.0 - 3.0 (51 - 76)	2.8 - 4.2 (71 - 107)	4.0 - 6.0 (102 - 152)
45° To Vertical	0.2 - 0.3 (5 - 8)	0.4 - 0.6 (10 - 15)	0.6 - 0.9 (15 - 23)	1.0 - 1.5 (25 - 38)	1.4 - 2.1 (36 - 53)	2.0 - 3.0 (51 - 76)

TROUBLESHOOTING CHART

The troubleshooting chart below identifies the most common symptoms of mechanical problems. Fault codes are also shown on the PV480 Digital Display unit on the Operator Control Panel.

Contact your authorized LeeBoy dealer for assistance, service or repair.

Table 5-1. Paver Troubleshooting

SYMPTOM	CAUSE	REMEDY
Engine does not start.	Defective battery or low battery charge.	Replace or charge battery as applicable.
	Master switch is not set at the ON position.	Set switch to the ON position
	Insufficient fuel supply.	Fill fuel tank.
	Solenoid doesn't function properly.	Ensure wires are tight. Clean solenoid plunger. Replace solenoid coil. Replace or rebuild starter or solenoid.
	Switch box unplugged.	Replug switch box.
	Neutral switch defective.	Replace.
	Engine starter relay faulty.	Replace.
	E-Stop engaged.	Disengage E-Stop.
Engine turns over but does not start.	Low fuel.	Add fuel to fuel tank.
Low battery.	Faulty alternator.	Replace or rebuild.
	Indicator light, bad bulb.	Replace.
Machine will not move.	RUN/STOP switch faulty.	Check RUN/STOP switch.
Machine does not steer straight.	One of the hydraulic drive motors needs adjustment.	Readjust motor(s).
	Steering control is not centered.	Center steering control.
	Travel pump defective.	Replace or rebuild travel pump.
Machine does not change speed when the 2-Speed switch is engaged.	Defective relay.	Replace relay.
	Defective solenoid.	Replace solenoid.
	Defective drive motor.	Replace drive motor.
Conveyor does not function on one or both sides.	Defective Automatic/Manual switch.	Replace switch.
	Solenoid defective.	Replace.
	Feeder drive chain broken.	Repair or replace chain.
	Defective conveyor motor.	Replace.
	Rear conveyor shaft broken.	Replace.

SYMPTOM	CAUSE	REMEDY
Tracks don't operate smoothly.	Tracks too loose.	Tighten track pad bolts.
	Engine RPM is too low to hold track tension.	Rev engine to 1800 RPMs then throttle back to 1300 RPMs.
	Track rollers worn.	Replace.
	Track tension pressure.	Check tension pressure and relieve or adjust.
Machine will not pull on one or both sides.	Faulty hydraulic motor.	Replace.
	Pump pressure too low.	Check pump pressure and relieve or adjust.
	Faulty torque hub.	Rebuild or replace.
Engine runs but there is no hydraulic pressure.	Pump drive coupling faulty.	Replace.
	Defective pump.	Replace.
Auger not turning properly.	Drive chain is too loose.	Adjust.
	Drive chain broken.	Replace.
	Faulty motor.	Replace.
	Solenoid valve defective.	Replace solenoid.
	Asphalt buildup.	Clean thoroughly and grease.
	Overload of material to augers.	Set conveyor to proper speed in AUTO or use paddles in MANUAL position.
Screed extensions binding.	Asphalt buildup.	Keep clean and greased.
Screed extension loose.	Out of adjustment.	Adjust hold-downs on extensions.
Screed leaving streak down center of pavement.	No lead crown in screed.	Crown leading edge of screed.
	Screed worn out or damaged.	Replace.
	Extensions set too low.	Adjust extension. Always begin operation with extensions extended up with no down pressure.
	Screed not heated properly.	Check elements and heat control box.
Screed leaving ripples in pavement.	Extension set too low.	Readjust extensions.
	Extensions work up and down.	Adjust top guide.
	Extension rod bushings worn.	Replace bushings.
Flight screw locking up.	Twisting screed too far.	Give screed time to react.
	Screw seized.	Replace screw.
Flight screw bearing damage.	Twisting screed too far.	Give screed time to react.
	Loading and unloading.	Check ramps for easy access.
Hydraulic oil leaking from breather cap.	Hydraulic oil tank overfilled.	Drain to proper fill level.
	Oil overheated.	Slow paver down. Check oil cooler and thermostat.
Hydraulic pump cavitation or lost power.	Low level in hydraulic tank.	Refill to proper level.
	Clogged filters.	Replace filters.
	Suction hose loose.	Retighten.
	Charge pump worn.	Rebuild or replace charge pump.

SYMPTOM	CAUSE	REMEDY
Feeder does not work on one or both sides.	Defective switch.	Replace switch.
	Solenoid defective.	Replace solenoid.
	Feeder drive chain broken.	Adjust or repair chain.
	Defective conveyor motor.	Replace motor.
	Rear conveyor shaft broken.	Replace conveyor shaft.
Feeder flight bars don't function properly.	Flight chains too loose.	Adjust.
	Feeder drive chain too loose.	Adjust.
Loss of power to drives.	Relief out of adjustment.	Check pressure and adjust if needed.
	Piston groups worn.	Replace.
	No charge pressure.	Check that charge pressure is 320 PSI.
Electric screed heating system will not operate.	Control box power switch not in ON position.	Ensure that the screed operator control box Power switch is ON.
	Breakers are in a "tripped position."	Ensure all element breakers are in the proper set position.
	Generator malfunction.	Check voltage and frequency. Rebuild or replace if needed.
Only part of the electric screed heats.	Screed section not plugged into bottom of the control box.	Replug.
	Element breakers for screed section in a "tripped" condition.	Ensure the element breakers for that screed section are not "tripped."
Electric screed heat system doesn't start, or starts and doesn't run very long.	Heating system timed out.	Check timing relay. Adjust or replace.
Electric Screed is heating, but never gets hot enough to pave.	Elements improperly clamped.	Ensure elements are clamped properly.
	Generator malfunction.	Ensure generator is "spinning." Check voltage and frequency. Rebuild or replace if needed.
Electric heating system functions but the HEAT ON light isn't illuminated.	Indicator light bulb.	Replace the HEAT ON indicator light bulb.
Elements have been tested, but the breaker still trips.	Faulty element wiring.	Inspect and test element wiring.

PV480 DIAGNOSTIC TROUBLE CODE (DTC) CHART

LEGEND

SPN: Suspect Parameter Number

EGR: Exhaust Gas Recirculation

NE-G: Negative Ground

SCV: Selective Control Valve

DC: Direct Current

PLV: Pressure Limiting Valve

DDC: Direct Digital Control

ETC: Electronic Throttle Control

MPROP: Manifold Pressure Rail Operating Pressure

EEPROM: Electrically Erasable Programmable Read-Only Memory

DPF: Diesel Particulate Filter

ECU: Engine Control Unit

NE: Neutral

MAF: Mass Air Flow

IC: Integrated Circuit

CAN: Controller Area Network

SW: Switch

CCVS: Current Controlled Voltage Source

FMI: Failure Mode Identifier

CPU: Central Processing Unit

G: Ground

PM: Particulate Matter

EBC: Electronic Brake Control

CM: Control Module

TSC: Torque Speed Control

SPN	FMI	DTC	SYMPTOM/CAUSE	RECOVERY FROM ERROR
29	3	Accelerator position sensor 2: High	Battery short circuit out of sensor/harness. Voltage of accelerator position sensor 2 is 4.8V or less.	Forced idle. (Accelerator = 0%) Diagnostic counter = zero
29	4	Accelerator position sensor 2: Low	Ground short circuit or open circuit of sensor/harness. Voltage of accelerator position sensor 2 is 0.3V or less.	Forced idle. (Accelerator = 0%) Diagnostic counter = zero
91	2	Accelerator position sensor correlation error	Deviation from designed correlation in two sensors. Voltage of accelerator position sensor 1 is 4.8V or less.	Forced idle. (Accelerator = 0%) Diagnostic counter = zero
91	3	Accelerator position sensor 1: High	Battery short circuit or open circuit of sensor/harness. Voltage of accelerator position sensor 1 is 4.8V or less.	Forced idle. (Accelerator = 0%) Diagnostic counter = zero
91	4	Accelerator position sensor 1: Low	Ground short circuit or open circuit of sensor/harness. Voltage of accelerator position sensor 1 is 0.3 or less.	Forced idle. (Accelerator = 0%) Diagnostic counter = zero
100	1	Oil pressure error.	Engine oil pressure.	Key switch turn OFF.
102	3	Boost pressure sensor: High	Failure of sensor. Voltage of boost pressure sensor is 4.9V or above.	Key switch turn OFF. (Default value is set in consideration with high altitude usage. Engine power drops.)
102	4	Boost pressure sensor: Low	Failure of sensor. Voltage of boost pressure sensor is 0.2V or below.	Key switch turn OFF. (Default value is set in consideration with high altitude usage. Engine power drops.)
108	3	Barometric pressure sensor error: High	Barometric voltage 4.4V or more.	Diagnostic counter = zero (Default value is set in consideration with high altitude usage. Engine power drops.)



SPN	FMI	DTC	SYMPTOM/CAUSE	RECOVERY FROM ERROR
108	4	Barometric pressure sensor error: Low	Barometric voltage 1.6V or less.	Diagnostic counter = zero (Default value is set in consideration with high altitude usage. Engine power drops.)
110	0	Engine overheat.	Overheat of engine temperature greater than 248° F (120° C)	Diagnostic counter = zero Output limitation: approximately 75% of normal condition. EGR stop. Intake throttle 100% open.
110	3	Coolant temperature sensor: High	Open circuit or +B short circuit of sensor/harness. Voltage of coolant temperature sensor is 4.9V or above.	Key switch turn OFF. (White smoke increases at low temperature.)
110	4	Coolant temperature sensor: Low	Ground short circuit of sensor/harness. Voltage of coolant temperature sensor is 0.1V or less.	Key switch turn OFF. (White smoke increases at low temperature.)
132	1	Intake air volume: Low	Engine inlet air mass flow rate tacking. (Disconnect turbo blower intake hose.)	Key switch turn OFF.
132	3	MAF sensor: High	Engine inlet air mass flow rate less than half of target value. MAF sensor voltage: 4.9V or more at normal operating condition.	Key switch turn OFF. Engine is not forcibly stopped by ECU. STRONGLY recommend operator stop engine promptly.
132	4	MAF sensor: Low	Open circuit or ground short circuit of sensor/harness. MAF sensor voltage: 0.1V or less.	Key switch turn OFF. Engine is not forcibly stopped by ECU. STRONGLY recommend operator stop engine promptly.
132	15	Boost pressure: Low	Boost pressure sensor output is below target level in high air flow operating conditions.	Key switch turn OFF. EGR stop. Engine power is restricted by boost pressure signal accordingly.
157	0	High rail pressure.	Actual pressure exceeds the command pressure. Actual pressure \geq 197MPa (28600 psi or 2010 kgf/cm ²)	Diagnostic counter = zero EGR stop.
157	3	Rail pressure sensor: High	Open circuit or +B short circuit of sensor/harness. Failure of sensor. Voltage or rail pressure sensor is 4.9V or above.	Key switch turn OFF. Engine running noise and white smoke increases. Engine forcibly stopped.
157	4	Rail pressure sensor: Low	Ground short circuit of sensor/harness. Failure of sensor. Voltage of rail pressure sensor is 0.7V or less.	Key switch turn OFF. Engine running noise and white smoke increases. Engine forcibly stopped.
168	3	Battery voltage: High	Open circuit, short circuit or damage to harness. Failure of battery. ECU recognition of battery voltage is above 16V in 12V system. Faulty starting.	Key switch turn OFF. EGR stop.
168	4	Battery voltage: Low	Open circuit, short circuit or damage to harness. Failure of battery. ECU recognition of battery voltage is below 8V in 12V system. Faulty starting or engine may stop completely. (Not monitored during cranking.)	Diagnostic counter = zero EGR stop.

SPN	FMI	DTC	SYMPTOM/CAUSE	RECOVERY FROM ERROR
171	3	Intake air temperature built-in MAF sensor: High	Open circuit or +B short circuit of sensor/harness. Intake air temperature built-in MAF sensor voltage: 4.9V or more.	Diagnostic counter = zero
171	4	Intake air temperature built-in MAF sensor: Low	Ground short circuit of sensor/harness. Intake air temperature built-in MAF sensor voltage: 0.1V or less.	Diagnostic counter = zero
172	0	Intake air temperature: High	Intake air temperature higher than 140° F (60° C).	Key switch turn OFF.
172	3	Intake air temperature error: High	Open circuit or +B short circuit of sensor/harness. Intake air temperature sensor is 4.9V or above.	Diagnostic counter = zero (White smoke increases at low temperature.)
172	4	Intake air temperature error: Low	Ground short circuit of sensor/harness. Intake air temperature sensor is 0.05V or less.	Diagnostic counter = zero (White smoke increases at low temperature.)
174	0	Fuel temperature high.	Fuel temperature higher than 194° F (90° C).	Diagnostic counter = zero
174	3	Fuel temperature sensor: High	Open circuit or +B short circuit of sensor/harness. Voltage of temperature sensor in supply pump is 4.9V or above.	Diagnostic counter = zero
174	4	Fuel temperature sensor: Low	Ground short circuit of sensor/harness. Voltage of temperature sensor in supply pump is 0.1V or less.	Diagnostic counter = zero
190	0	Engine speed.	Engine speed exceeds threshold speed. Engine speed \geq 3500 min ⁻¹ (rpm).	Diagnostic counter = zero
628	2	Program memory.	Check-Sum error.	Key switch turn OFF. Engine stopped without delay.
633	7	Pressure limiter emergency open.	Combination of fuel leak and one of conditions below: 1. Rail pressure exceeds 191MPa (27700 psi or 1950 kgf/cm ²). 2. Within one second after the rail pressure goes below temperature in #1, it increases above.	Key switch turn OFF. EGR stop. (Engine speed may go down due to lack of fuel pressure.)
636	2	Crank position sensor pulse number error.	Open circuit or short circuit of sensor/harness. Failure of sensor. Pulse rotation is not 56 teeth. Faulty starting. Engine vibration increases slightly.	Diagnostic counter = zero
636	7	NE-G phase shift. NE: Crankshaft position sensor. G: Camshaft position sensor.	Large phase shift between NE and G pulses within +/- 15 degrees. Engine hesitates at start-up.	Diagnostic counter = zero
636	8	No input of NE sensor pulse.	Open circuit or short circuit of sensor/harness. Failure of sensor. No recognition of NE sensor pulse. Faulty starting. Engine vibration increases slightly.	Diagnostic counter = zero

SPN	FMI	DTC	SYMPTOM/CAUSE	RECOVERY FROM ERROR
651	3	Open circuit of harness/coil in 1st cylinder injector.	Open circuit of harness or injector coil. Engine vibration increases. Injectors that have no error are operated.	Key switch turn OFF.
652	3	Open circuit of harness/coil in 2nd cylinder injector.	Open circuit of harness or injector coil. Engine vibration increases. Injectors that have no error are operated.	Key switch turn OFF.
653	3	Open circuit of harness/coil in 3rd cylinder injector.	Open circuit of harness or injector coil. Engine vibration increases. Injectors that have no error are operated.	Key switch turn OFF.
654	3	Open circuit of harness/coil in 4th cylinder injector.	Open circuit of harness or injector coil. Engine vibration increases. Injectors that have no error are operated.	Key switch turn OFF.
676	0	Glow heater relay driving circuit overheat.	Glow relay coil resistance or load is too high. Faulty starting. White smoke increases.	Key switch turn OFF.
676	5	Open circuit of glow relay driving circuit.	Open circuit of harness or relay coil. Faulty starting. White smoke increases.	Key switch turn OFF.
679	7	Pressure limiter not open.	Rail pressure value is sticking or not enough engine power to open PLV forcibly.	Key switch turn OFF.
723	2	G sensor pulse number error.	After fault opening PLV, rail pressure is above 160 MPa.	Diagnostic counter = zero Engine stops.
723	8	No input of G sensor pulse.	Open circuit or short circuit of sensor/harness. Failure of sensor. No recognition of G sensor pulse. Engine hesitates at start-up.	Diagnostic counter = zero
1077	2	Failure of CPU.	CPU fatal error. Engine stops.	Key switch turn OFF.
1239	1	Fuel leak in high-pressured fuel system.	Fuel consumption is calculated from the difference of fuel pressure of, before and after the injection. Error is detected when excess fuel consumption is found. Engine could stop.	Key switch turn OFF.
1347	3	+B short circuit of SCV.	EGR stops.	Key switch turn OFF.
1347	4	SVC drive system error.	Open circuit or ground short circuit of SCV.	Key switch turn OFF. EGR stops, engine forcibly stops later.
1347	5	Open circuit of SCV (MPROP)	Open circuit short of SVC.	Key switch turn OFF. EGR stops, engine forcibly stops later.
1347	7	SCV stuck in open position.	Actual rail pressure continuously exceeds the command rail pressure. Discharge request of supply pump goes below 0 mm ³ /st and the actual rail pressure is 10 MPa for 26 seconds or more. Engine may stop.	Key switch turn OFF.
1485	2	Main relay locked in closed position.	Failure of main relay. Stays active longer than one second without command. Battery goes dead.	Diagnostic counter = zero

SPN	FMI	DTC	SYMPTOM/CAUSE	RECOVERY FROM ERROR
3242	0	Emergency exhaust gas temperature sensor 1: High	DPF inlet temperature higher than 1319° F (715° C). Engine stops. Inhibit starter relay activation until exhaust temperatures reduces down to 572° F (300° C).	Under 572° F (300° C) and key switch turn OFF.
3242	3	Exhaust gas temperature sensor 1: High	Open circuit or +B short circuit of sensor/harness. DPF inlet temperature sensor voltage 4.92V or more.	Key switch turn OFF.
3242	4	Exhaust gas temperature sensor 1: Low	Ground short circuit of sensor/harness. DPF inlet temperature sensor voltage 0.08V or less.	Key switch turn OFF.
3246	0	Emergency exhaust gas temperature sensor 2: High	DPF outlet temperature 1508° F (820° C) or more.	Under 572° F (300° C) and key switch turn OFF. Inhibit starter relay activation until exhaust temperature reduces down to 572° F (300° C).
3246	3	Exhaust gas temperature sensor 2: High	Open circuit or +B short circuit of sensor/harness. DPF outlet temperature sensor voltage 4.92V or more.	Key switch turn OFF.
3246	4	Exhaust gas temperature sensor 2: Low	Ground short circuit of sensor/harness. DPF outlet temperature sensor voltage 0.08V or less.	Key switch turn OFF.
3251	3	Differential pressure sensor 1: High	Open circuit or +B short circuit of sensor/harness. DPF differential pressure sensor voltage 4.7V or more.	Key switch turn OFF.
3251	4	Differential pressure sensor 1: Low	Ground short circuit of sensor/harness. DPF differential pressure sensor voltage 0.21V or less.	Key switch turn OFF.
3252	0	Emission deterioration.	DOC is heated due to unburned fuel. Output and accelerator limitation 50%. EGR stops.	Key switch turn OFF to minimize emission to DPF.
3509	3	Sensor supply voltage 1: High	Voltage to sensor is above 5.625V. EGR stops. Faulty starting. Engine may stop. Emission related.	Key switch turn OFF.
3509	4	Sensor supply voltage 1: Low	Voltage to sensor is below 4.375V. EGR stops. Faulty starting. Engine may stop. Emission related.	Key switch turn OFF.
3510	3	Sensor supply voltage 2: High	Voltage to sensor is above 5.625V. Faulty starting. Emission related.	Key switch turn OFF.
3510	4	Sensor supply voltage 2: Low	Voltage to sensor is below 4.375V. Faulty starting. Emission related.	Key switch turn OFF.
3511	3	Sensor supply voltage 3: High	Voltage to sensor is above 5.25V. Faulty starting.	Key switch turn OFF.
3511	4	Sensor supply voltage 3: Low	Voltage to sensor is below 4.75V. Faulty starting.	Key switch turn OFF.

SPN	FMI	DTC	SYMPTOM/CAUSE	RECOVERY FROM ERROR
3701	0	Excessive PM 5.	PM accumulation more than trigger level. Regeneration Level = 5.	Key switch turn OFF. Engine not forcibly stopped by ECU. STRONGLY recommend operator to stop engine promptly. Must be reset by Kubota service tool.
3701	15	Excessive PM 3.	PM accumulation more than trigger level. Regeneration Level = 3.	Diagnostic counter = 0
3701	16	Excessive PM 4.	PM accumulation more than trigger level. Regeneration Level = 4.	Diagnostic counter = 0
4765	0	Emergency exhaust gas temperature sensor 0: High	DOC inlet temperature 1292° F (700° C) or more. Engine stops.	Key switch turn OFF. Inhibit starter relay activation until exhaust temperature reduces down to 527° F (300° C).
4765	3	Exhaust gas temperature sensor 0: High	Open circuit or +B short circuit of sensor/harness. DOC inlet temperature sensor voltage 4.92V or more.	Key switch turn OFF.
4765	4	Exhaust gas temperature sensor 0: Low	Open circuit or +B short circuit of sensor/harness. DOC inlet temperature sensor voltage 0.08V or less.	Key switch turn OFF.
523523	2	Injector drive circuit open in Nos. 1 & 4 cylinder simultaneously.	Wiring harness open circuit. Injectors that have no DTC are operated. Engine vibration increases and may stop.	Key switch turn OFF.
523523	3	Nos. 1 & 4 cylinder injector short to +B at power supply side, or all cylinder injectors short to +B.	Wiring harness short to +B. Injectors that have no DTC are operated. Engine vibration increases and may stop.	Key switch turn OFF.
523523	4	Nos. 1 & 4 cylinder injector short to ground at power supply side, or all cylinder injectors short to ground.	Wiring harness short to ground. Injectors that have no DTC are operated. Engine vibration increases and may stop.	Key switch turn OFF.
523524	2	Injector drive circuit open in Nos. 2 & 3 cylinder simultaneously.	Wiring harness open circuit. Injectors that have no DTC are operated. Engine vibration increases and may stop.	Key switch turn OFF.
523524	3	Nos. 2 & 3 cylinder injector short to +B at power supply side, or all cylinder injectors short to +B.	Wiring harness short to +B. Injectors that have no DTC are operated. Engine vibration increases and may stop.	Key switch turn OFF.
523524	4	Nos. 2 & 3 cylinder injector short to ground at power supply side, or all cylinder injectors short to ground.	Wiring harness short to ground. Injectors that have no DTC are operated. Engine vibration increases and may stop.	Key switch turn OFF.
523525	1	Injector charge voltage low.	Injector charge voltage low. Failure of charge circuit of ECU. Engine may stop.	Key switch turn OFF.

SPN	FMI	DTC	SYMPTOM/CAUSE	RECOVERY FROM ERROR
523527	2	ECU monitoring error.	Failure of monitoring IC of CPU. Engine stops.	Key switch turn OFF.
523535	0	Injector charge voltage: High	EGR stops. Engine forcibly stops 60 seconds later.	Key switch turn OFF.
523536	2	EGR feedback error.	DC motor feedback control error. During wrong duty feedback, activation of restoration will repeat 30 times. If the restoration was not successfully completed, it will be judged as a feedback error. EGR stops.	Diagnostic counter = zero
523537	2	EGR DC motor temperature error.	Estimated temperature is 113° F (45° C) or above. EGR stops.	Diagnostic counter = zero
523538	2	QR data error.	QR data read error from EEPROM. Nozzle correction is not executed.	Key switch turn OFF.
523539	2	Pump seizing 1.	Rail pressure of 230 MPa (33400 psi or 2350 kgf/cm ²) or more continues one second under the condition of above 800 min-1 (rpm). Under 800 min-1 (rpm) condition, rail pressure of 220 MPa (31900 psi or 2250 kgf/cm ²) or more continues one second under the condition of below 800 min-1 (rpm). [Threshold changes depending upon the engine speed. 700 min-1 (rpm) should be used as a reference.	Key switch turn OFF to minimize PM emission to DPF and avoid extremely high pressure in injection system.
523540	2	Pump seizing 2.	Rail pressure of 197MPa (28600 psi or 2010 kgf/cm ²) or more continues one second under the condition of above 800 min-1 (rpm). Under 800 min-1 (rpm) condition, rail pressure of 220 MPa (31900 psi or 2250 kgf/cm ²) or more continues one second under the condition of below 800 min-1 (rpm). [Threshold changes depending upon the engine speed. 700 min-1 (rpm) should be used as a reference.	Key switch turn OFF.
523541	3	EGR lift sensor: High	+B short circuit of sensor/harness. Failure of sensor. Voltage of ECR lift sensor is 4.5V or above. EGR stops.	Key switch turn OFF.
523541	4	EGR lift sensor: Low	Open circuit or short circuit of sensor/harness. Failure of sensor. Voltage of ECR lift sensor is 0.3V or less. EGR stops.	Key switch turn OFF.
523543	2	Accelerator position sensor error (CAN).	Accelerator position sensor signal error (sensor/harness open circuit, ground short circuit, etc.).	Diagnostic counter = zero. CAN signal recovers.
523544	3	+B short of air heater relay driving circuit.	+B short circuit of harness. Faulty starting. White smoke increases.	Key switch turn OFF.

SPN	FMI	DTC	SYMPTOM/CAUSE	RECOVERY FROM ERROR
523544	4	Ground short of air heater relay driving circuit.	Ground short or open circuit of harness.	Key switch turn OFF.
523547	2	CAN2 bus off.	CAN2 bus off.	Key switch turn OFF.
523548	2	CAN-KBT frame error.	CAN-KBT frame open circuit error.	Key switch turn OFF.
523572	4	EGR position sensor failure.	EGR position sensor error signal received via CAN. EGR stops.	Key switch turn OFF.
523574	3	EGR actuator open circuit.	EGR actuator open error signal received via CAN. EGR stops.	Key switch turn OFF.
523575	7	EGR actuator valve stuck.	EGR actuator valve stuck error received via CAN. EGR stops.	Key switch turn OFF.
523576	2	EGR (DC motor) overheat.	EGR (DC motor) temperature error signal received via CAN (exceeds 257° F or 125° C). EGR stops.	Key switch turn OFF.
523577	2	EGR (DC motor) temperature sensor failure.	EGR (DC motor) temperature sensor error signal received via CAN. EGR stops.	Key switch turn OFF.
523578	2	No communication with EGR.	Interruption of CAN. EGR stops.	Key switch turn OFF.
523580	2	Intake throttle feedback error.	Deviation of throttle position is not corrected in 20 times of duty error recovery action.	Key switch turn OFF.
523582	3	Intake throttle lift sensor: High	Intake throttle lift sensor voltage 4.89V or more.	Key switch turn OFF.
523582	4	Intake throttle lift sensor: Low	Intake throttle lift sensor voltage 0.1V or less.	Key switch turn OFF.
523589	17	Low coolant temperature in parked regeneration.	During regeneration mode, engine warm-up condition is not satisfied because coolant temperature is too low (below 149° F or 65° C).	Diagnostic counter = zero Leaving from Parked active regeneration status.
523590	16	Parked regeneration timed out.	Regeneration incomplete due to low temperature of DPF.	Diagnostic counter = zero Leaving from Parked active regeneration status.
523591	2	CAN CCVS (parking and vehicle speed) frame error.	CAN CCVS frame time-out error. Parking SW = off. Vehicle speed = 0	Key switch turn OFF.
523592	2	CAN CM1 (Regen SW) frame error.	CAN CM1 frame time-out error. Regeneration inhibit = on. Parked regeneration SW = off.	Key switch turn OFF.
523593	2	CAN DDC1 (transmission) frame error.	CAN DDC1 frame time-out error.	Key switch turn OFF.
523594	2	CAN ETC2 (neutral SW) frame error.	CAN ETC2 frame time-out error	Key switch turn OFF.
523595	2	CAN ETC5 (neutral SW) frame error.	CAN ETC5 frame time-out error.	Key switch turn OFF.
523596	2	CAN TSC1 frame error.	No request to "TSC1 buffer" continues three times after over-ride control request (other than 0x00).	Diagnostic counter = zero

PV480 Troubleshooting

Under certain conditions, the PV480 digital display can become inoperable. If the display screen is completely black, it must be replaced. If the gauges on the screen become gray (**Figure 5-52**), the display panel is not receiving communication over the CANbus. If this occurs, check the connector. If the gauges are still gray, check the ECU powering up.



Figure 5-52. Gauges Grayed on Screens

Check PV480 Connector

1. Ensure the ignition switch is in the OFF position before starting the machine.
2. Remove the main connector from the rear of the PV480 digital display controller.
3. Inspect the terminals in positions 14 (green) and 26 (yellow) for the CANbus communication.
4. If terminals are properly seated, carefully “unlock” the red retaining clip and slide away from the wires. (**Figure 5-53**)



Figure 5-53. PV480 Main Connector

5. Ensure all the other terminals are locked into the connector shell.
6. Push the red retaining clip back into the locked position and ensure terminals are flush with the red retaining clip. (**Figure 5-54**)



Figure 5-54. Terminal Seat

7. Reinstall connector on to the PV480 panel, making sure the connector shell locks into its mate on the display panel.

5

Check ECU Powering Up

Each engine has a power distribution block (PDB) on the main engine harness that provides power to the ECU through the ECU control relay; main relay; and fuses in Positions 1, 2, 3, 4 and 8. **(Figure 5-55)**

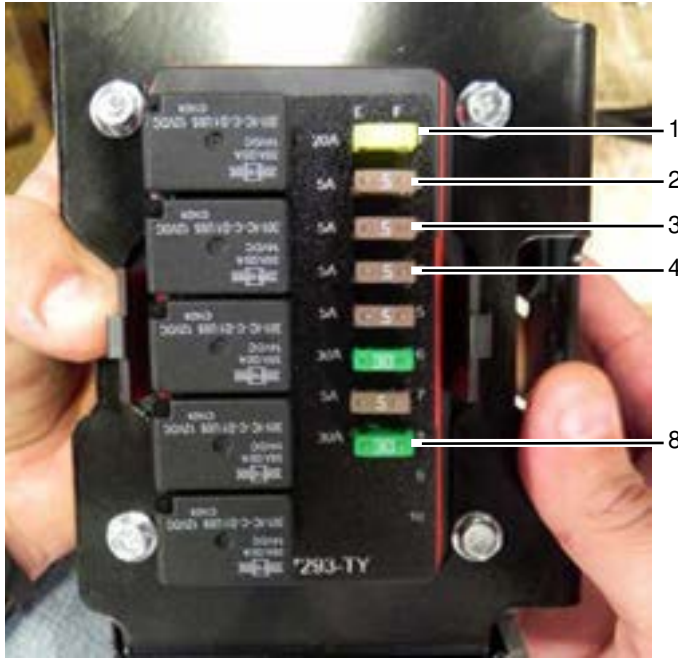

Figure 5-55. Power Distribution Box (PDB)

To check the ECU powering up:

1. Locate the PDB on the right side of the paver inside the engine access door.
2. Fuses can be checked by removing the fuse and using a continuity tester OR checking for +12VDC on each pin on the back of the fuse.
3. Confirm operation of ECU and main relays:
 - If the ECU relay is not energizing, starter will not operate.
 - If the main relay is not energizing, the fuel pump will not operate.

If none of these procedures correct the problem, contact your authorized LeeBoy dealer for assistance.

PLUS ONE CONTROLLER

The Plus One 50-pin controller monitors paver control systems and alerts the operator in the event of a fault. The Plus One status light on the control panel **(Figure 5-56)** illuminates green and blinks continuously or blinks, then pauses, then blinks again, depending upon the fault or mode. Some fault codes will also display on the PV480 digital controller. (See blink code tables on the following page.)



Figure 5-56. Plus One Light

- The Plus One will not allow the engine to start if any joystick is out of neutral or more than one Run/Stop switch is in the RUN position.
- If the paver is running in neutral for a certain length of time without movement, the Plus One system will disable. **The operator must then toggle the Run/Stop switch from RUN to STOP and back to RUN again to regain control.**

These faults will also prevent machine movement:

- Steering control box not detected.
- Joysticks not optimized.
- Pump control coil fault.
- Brake valve/pump neutral bypass coil fault.
- There is only one steering control box present.
- The fault happens in the steering control box that has control (Run/Stop switch in the RUN position).
- The fault occurs when neither steering control box is in control.



Section 6

SCHEMATICS

	Page
Schematics	6-1
Main Harness - 4 Function Screed Control (1 of 8)	6-3
Main Harness - 4 Function Screed Control (2 of 8)	6-5
Main Harness - 4 Function Screed Control (3 of 8)	6-7
Main Harness - 4 Function Screed Control (4 of 8)	6-9
Main Harness - 4 Function Screed Control (5 of 8)	6-11
Main Harness - 4 Function Screed Control (6 of 8)	6-13
Main Harness - 4 Function Screed Control (7 of 8)	6-15
Main Harness - 4 Function Screed Control (8 of 8)	6-17
Main Harness - 9 Function Screed Control (1 of 8)	6-19
Main Harness - 9 Function Screed Control (2 of 8)	6-21
Main Harness - 9 Function Screed Control (3 of 8)	6-23
Main Harness - 9 Function Screed Control (4 of 8)	6-25
Main Harness - 9 Function Screed Control (5 of 8)	6-27
Main Harness - 4 Function Screed Control (6 of 8)	6-29
Main Harness - 9 Function Screed Control (7 of 8)	6-31
Main Harness - 9 Function Screed Control (8 of 8)	6-33
Control Box Assembly - 4 Function Screed Control (1 of 3)	6-35
Control Box Assembly - 4 Function Screed Control (2 of 3)	6-37
Control Box Assembly - 4 Function Screed Control (3 of 3)	6-39
Control Box Assembly - 9 Function Screed Control (1 of 3)	6-41
Control Box Assembly - 9 Function Screed Control (2 of 3)	6-43
Control Box Assembly - 9 Function Screed Control (3 of 3)	6-45
C4 Dash to Pedestal Jumper Harness	6-47
C3 Dash to Pedestal Jumper Harness	6-49



Schematics

Screed Control Box Assembly, 4 Function - Left	6-51
Screed Control Box Assembly, 4 Function - Right.	6-53
Screed Control Box Assembly, 9 Function - Left	6-55
Screed Control Box Assembly, 9 Function - Right.	6-57
Screed Heat Control Box Assembly (1 of 2)	6-59
Screed Heat Control Box Assembly (2 of 2).	6-61
Screed Automatic Temperature Control	6-63
Lower Manifold Harness	6-65
Hydraulic Cooler Harness	6-67
Hydraulic Cooler Harness - SPAL Fan	6-69
Generator Valve Adapter Harness	6-71
Load Control box to Bulkhead Harness.	6-73
Bulkhead to Generator Harness	6-75
Joystick Control Box	6-77
Steering Wheel Control Box	6-79
Electronic Steering Cord.	6-81
Screed Berm Wiring Schematic	6-83
Hydraulic Schematic (1 of 5)	6-85
Hydraulic Schematic (2 of 5)	6-87
Hydraulic Schematic (3 of 5)	6-89
Hydraulic Schematic (4 of 5)	6-91
Hydraulic Schematic (5 of 5)	6-93

MAIN HARNESS - 4 FUNCTION SCREED CONTROL (1 OF 8)

Schematic for Part # 1016579

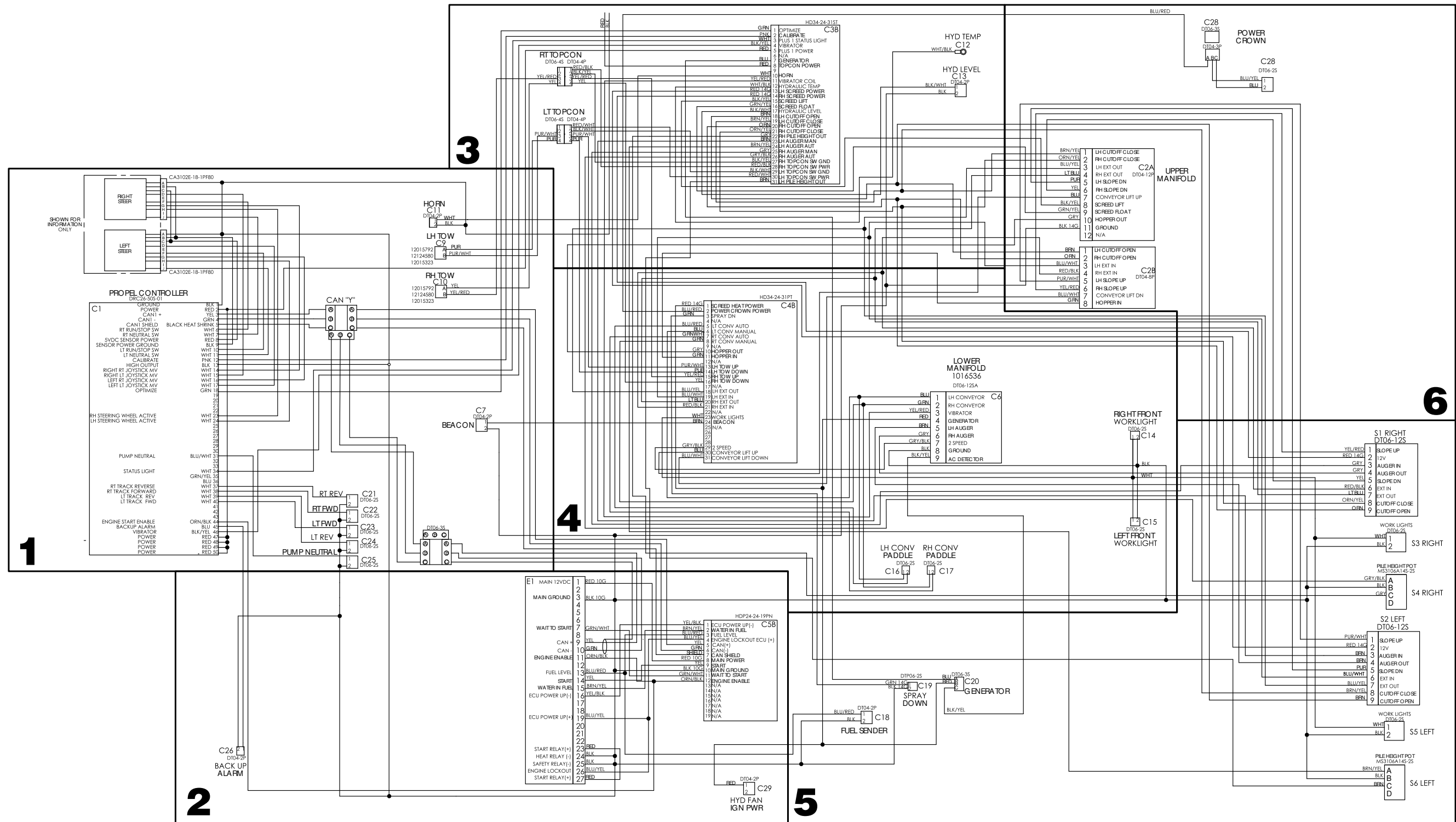

Figure 6-1. Main Harness - 4 Function Screed Control (1 of 8)

NOTES

MAIN HARNESS - 4 FUNCTION SCREED CONTROL (2 OF 8)

Schematic for Part # 1016579

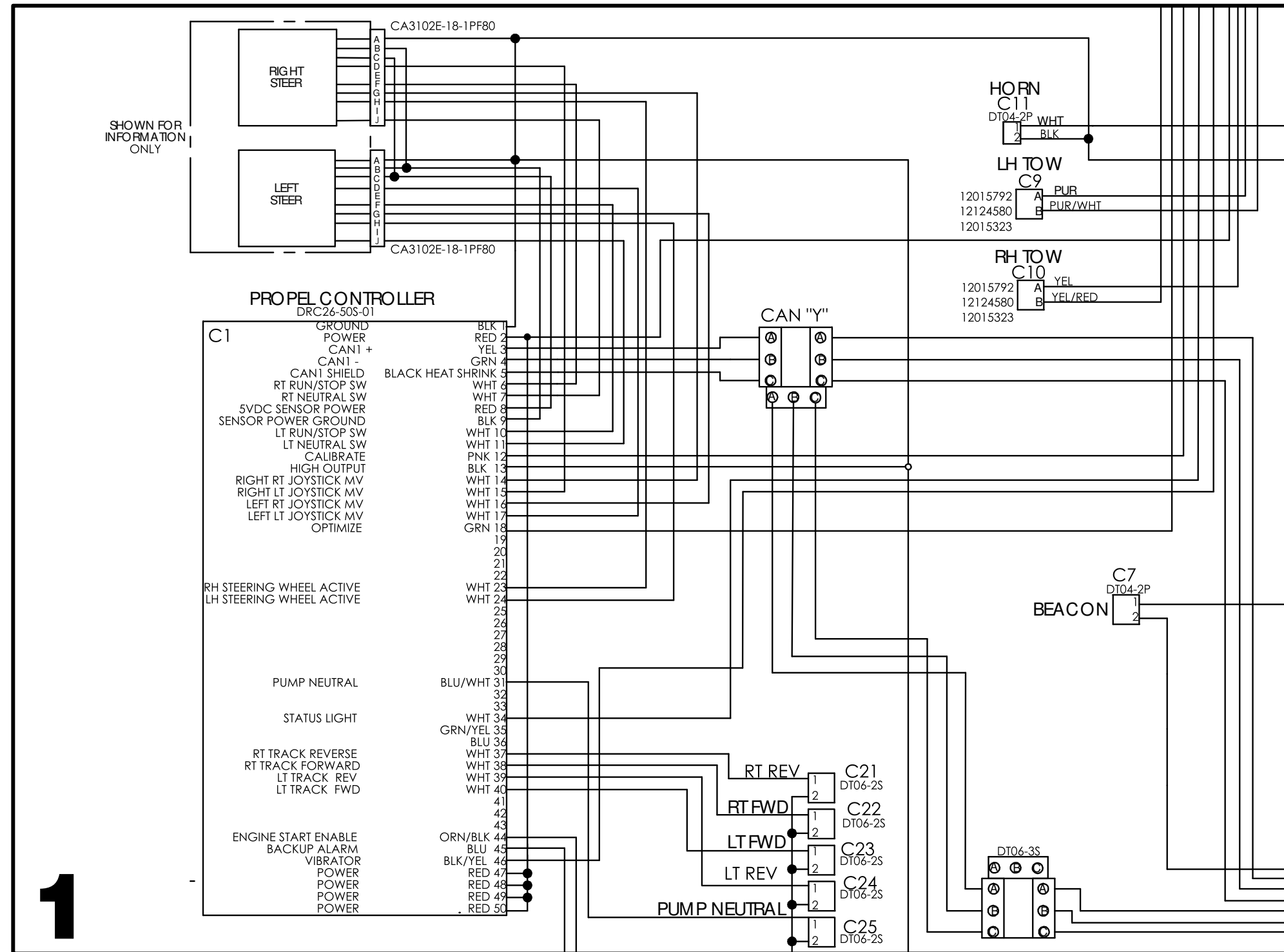

Figure 6-2. Main Harness - 4 Function Screed Control (2 of 8)

NOTES

MAIN HARNESS - 4 FUNCTION SCREED CONTROL (3 OF 8)

Schematic for Part # 1016579

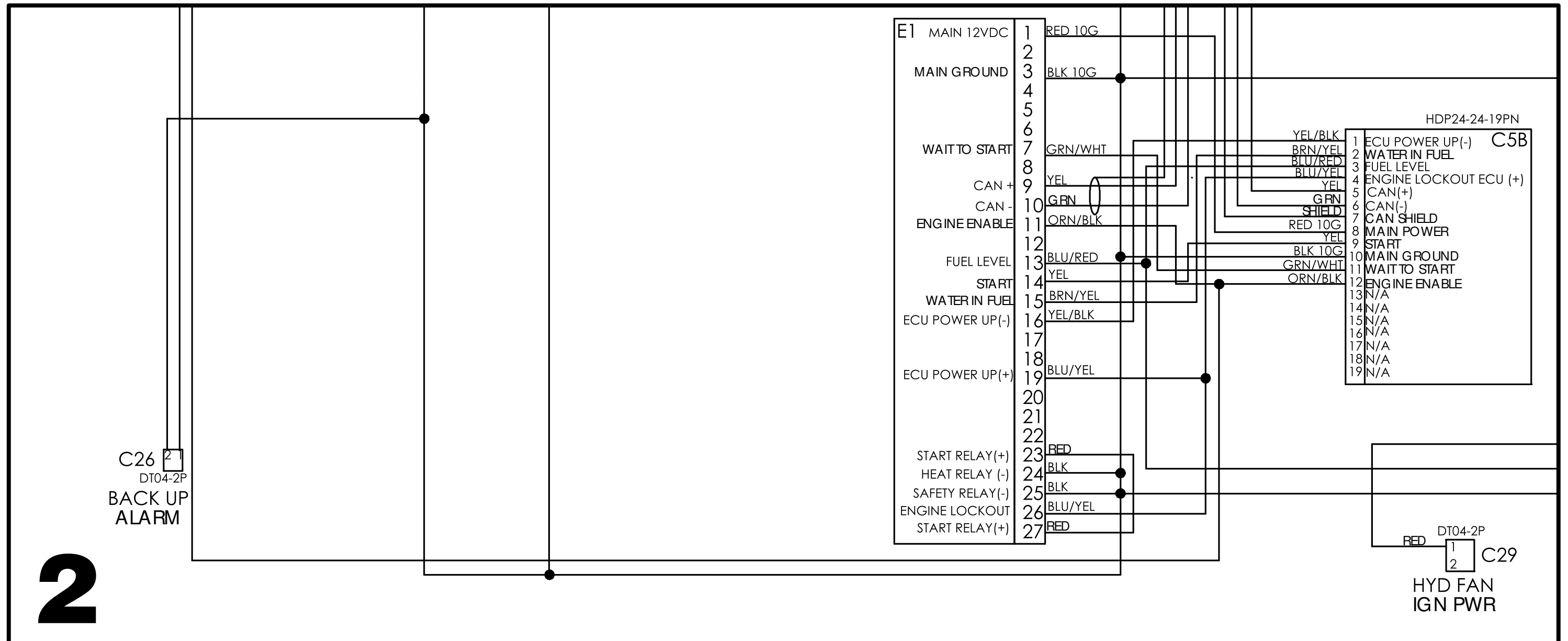

Figure 6-3. Main Harness - 4 Function Screed Control (3 of 8)

NOTES

MAIN HARNESS - 4 FUNCTION SCREED CONTROL (4 OF 8)

Schematic for Part # 1016579

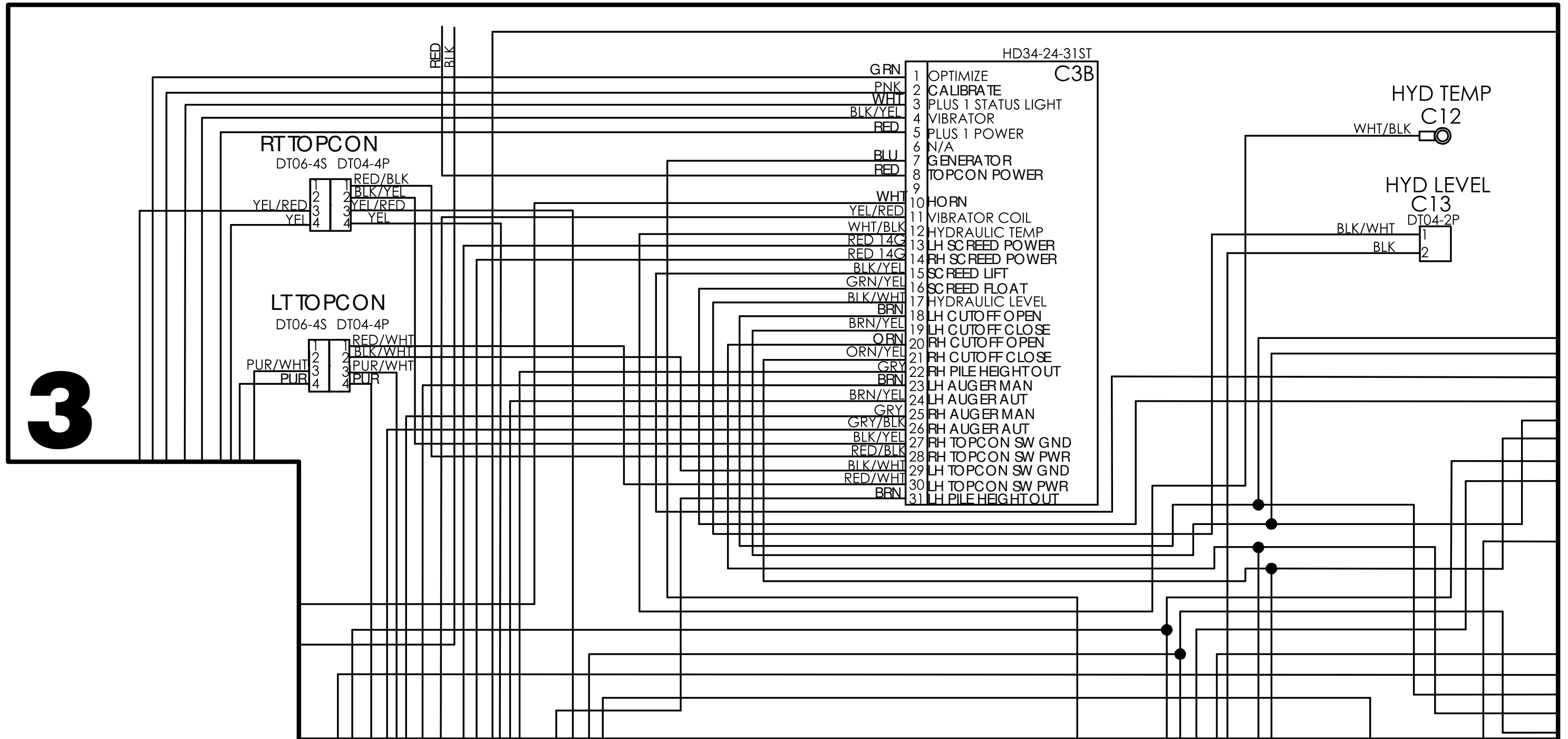

Figure 6-4. Main Harness - 4 Function Screed Control (4 of 8)

NOTES

MAIN HARNESS - 4 FUNCTION SCREED CONTROL (5 OF 8)

Schematic for Part # 1016579

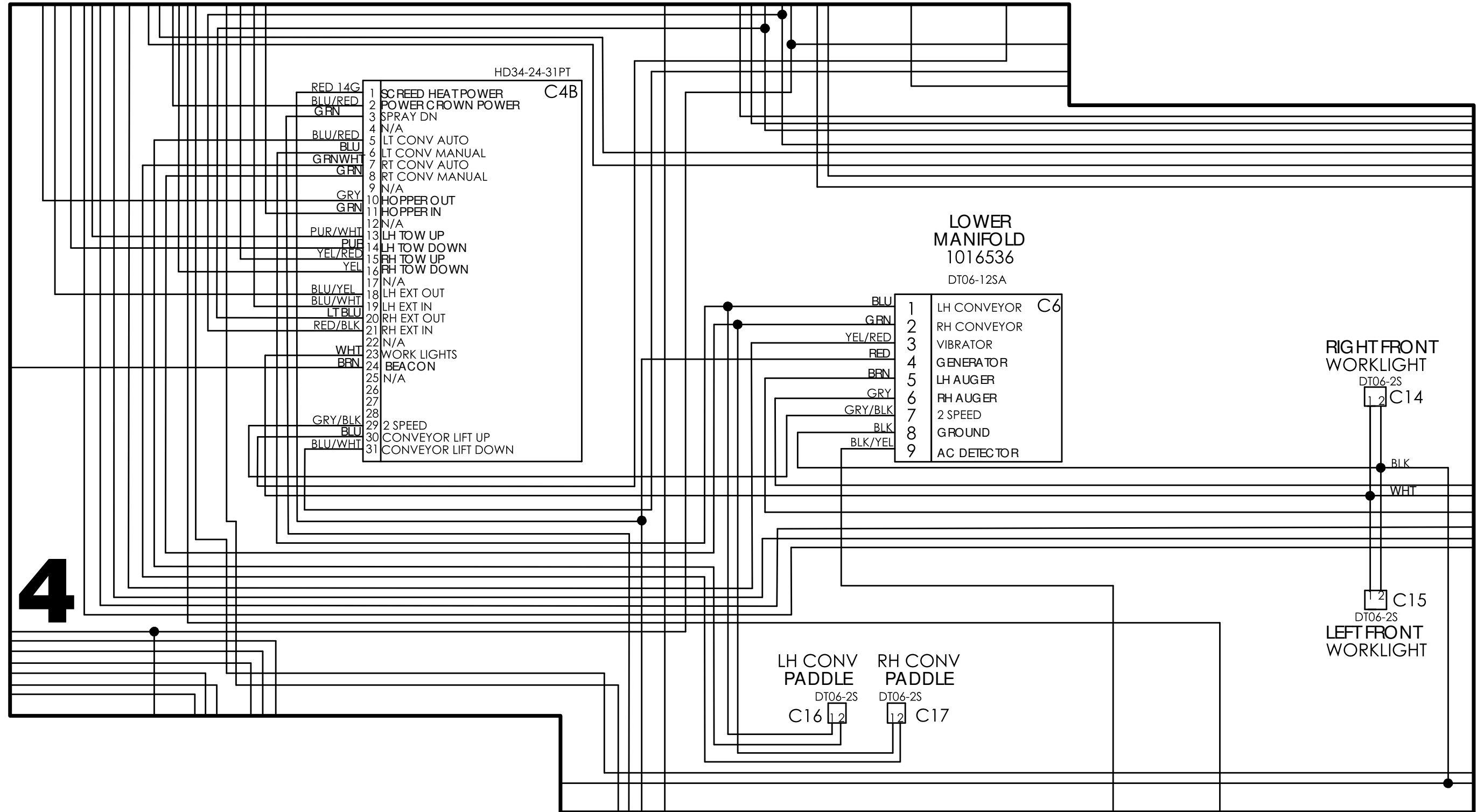
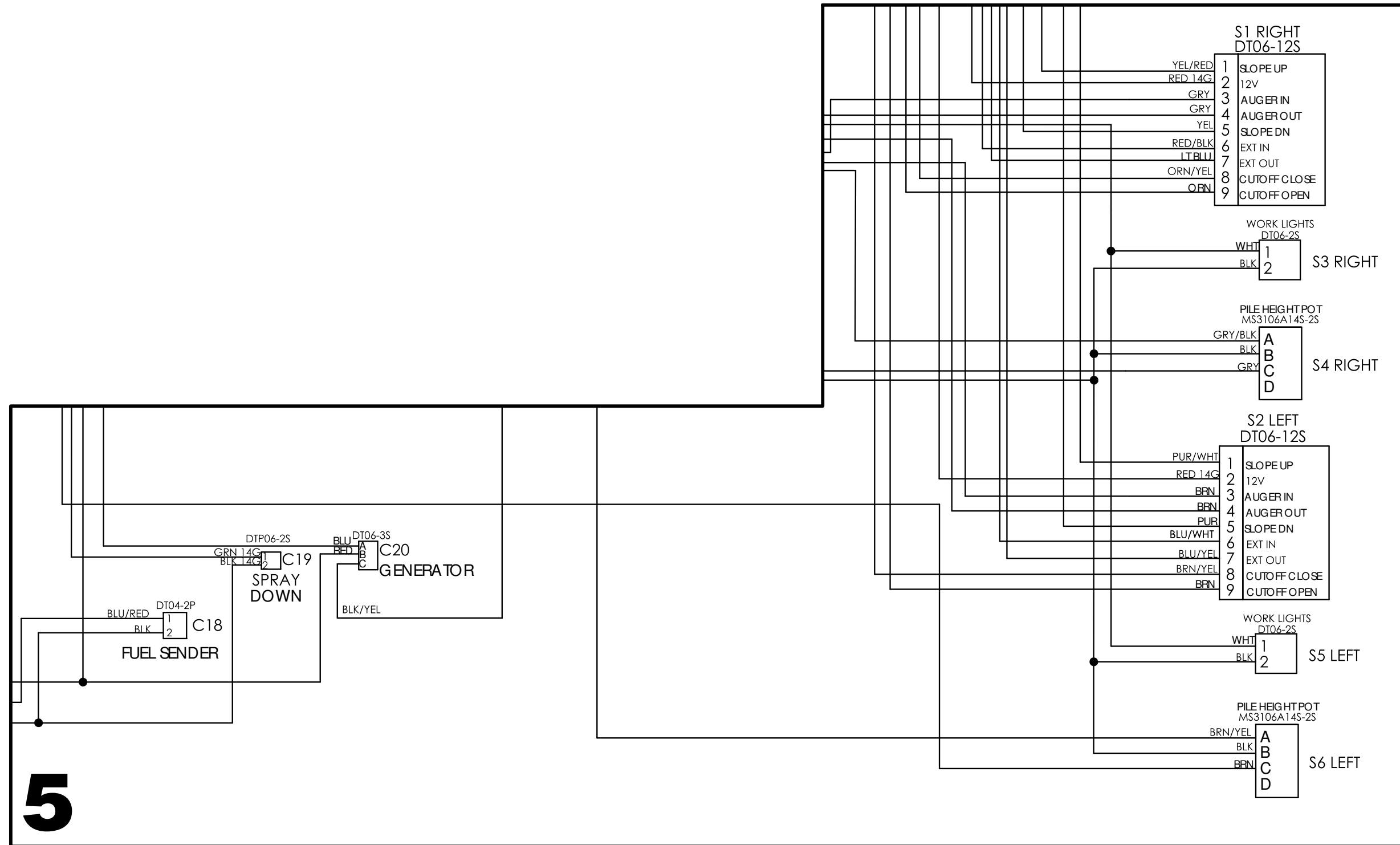

Figure 6-5. Main Harness - 4 Function Screed Control (5 of 8)

NOTES

MAIN HARNESS - 4 FUNCTION SCREED CONTROL (6 OF 8)

Schematic for Part # 1016579



6

Figure 6-6. Main Harness - 4 Function Screed Control (6 of 8)

NOTES

MAIN HARNESS - 4 FUNCTION SCREED CONTROL (7 OF 8)

Schematic for Part # 1016579

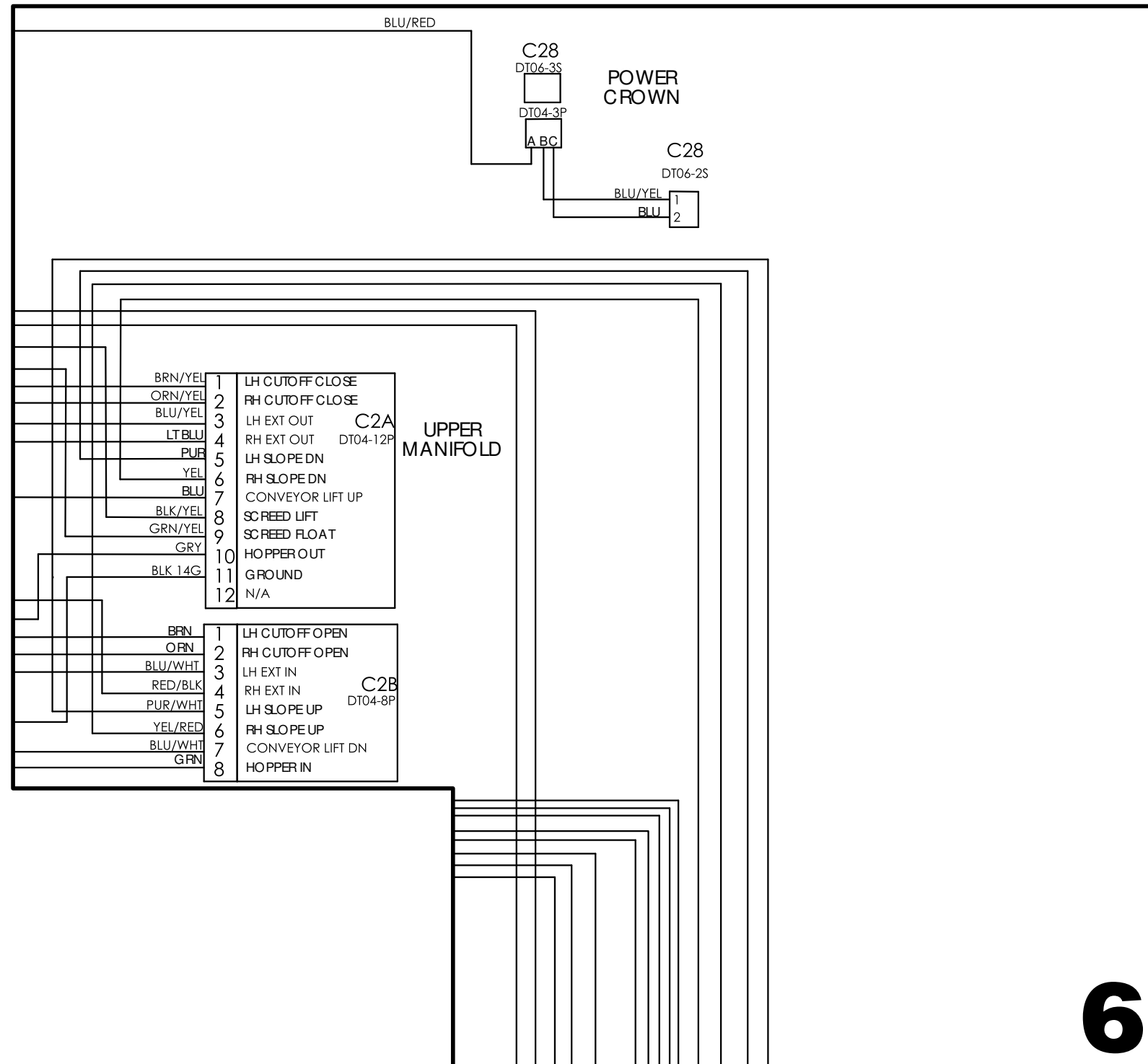

Figure 6-7. Main Harness - 4 Function Screed Control (7 of 8)

NOTES

MAIN HARNESS - 4 FUNCTION SCREED CONTROL (8 OF 8)

Schematic for Part # 1016579

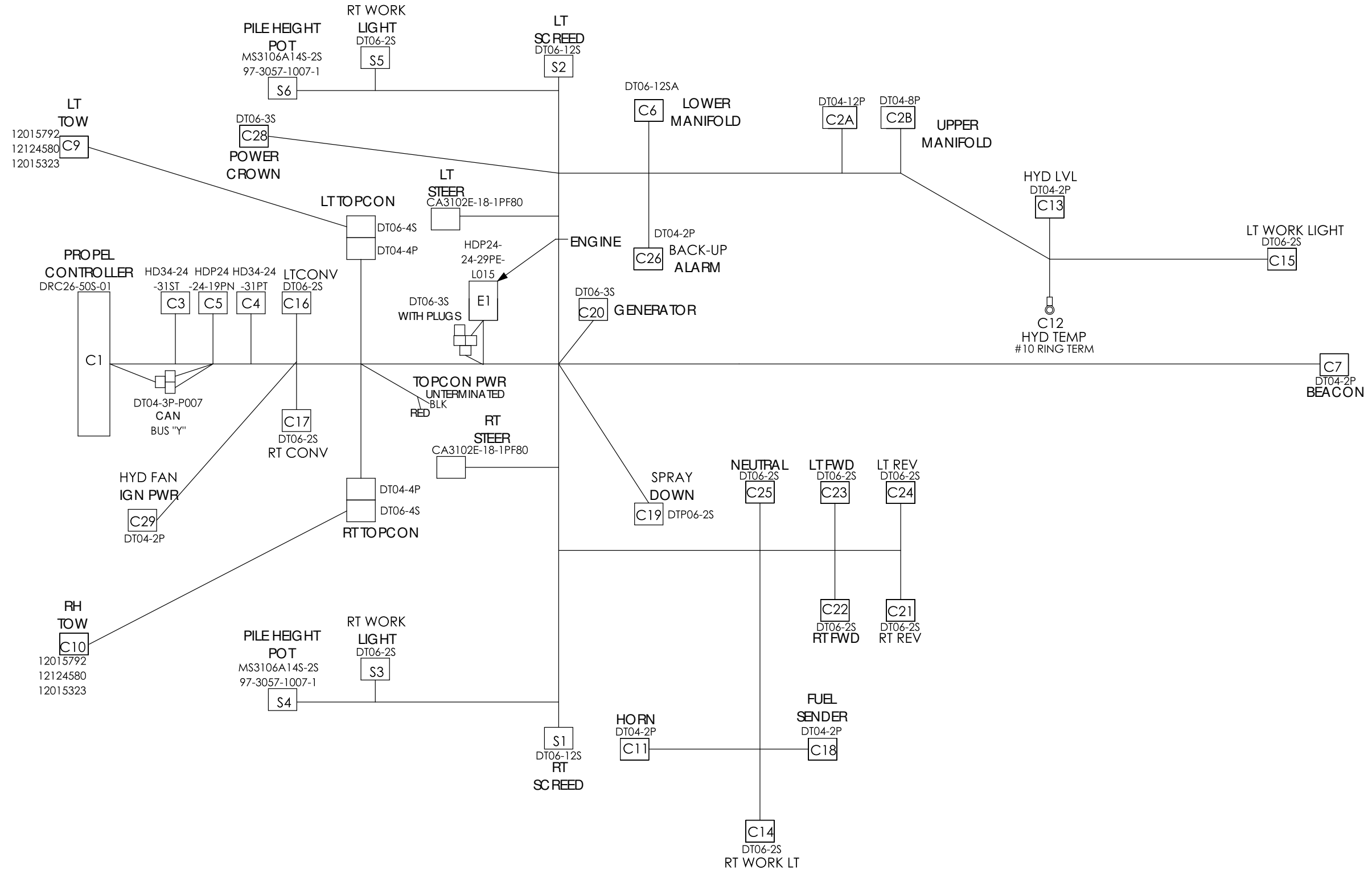

Figure 6-8. Main Harness - 4 Function Screed Control (8 of 8)

NOTES

MAIN HARNESS - 9 FUNCTION SCREED CONTROL (1 OF 8)

Schematic for Part # 1017840

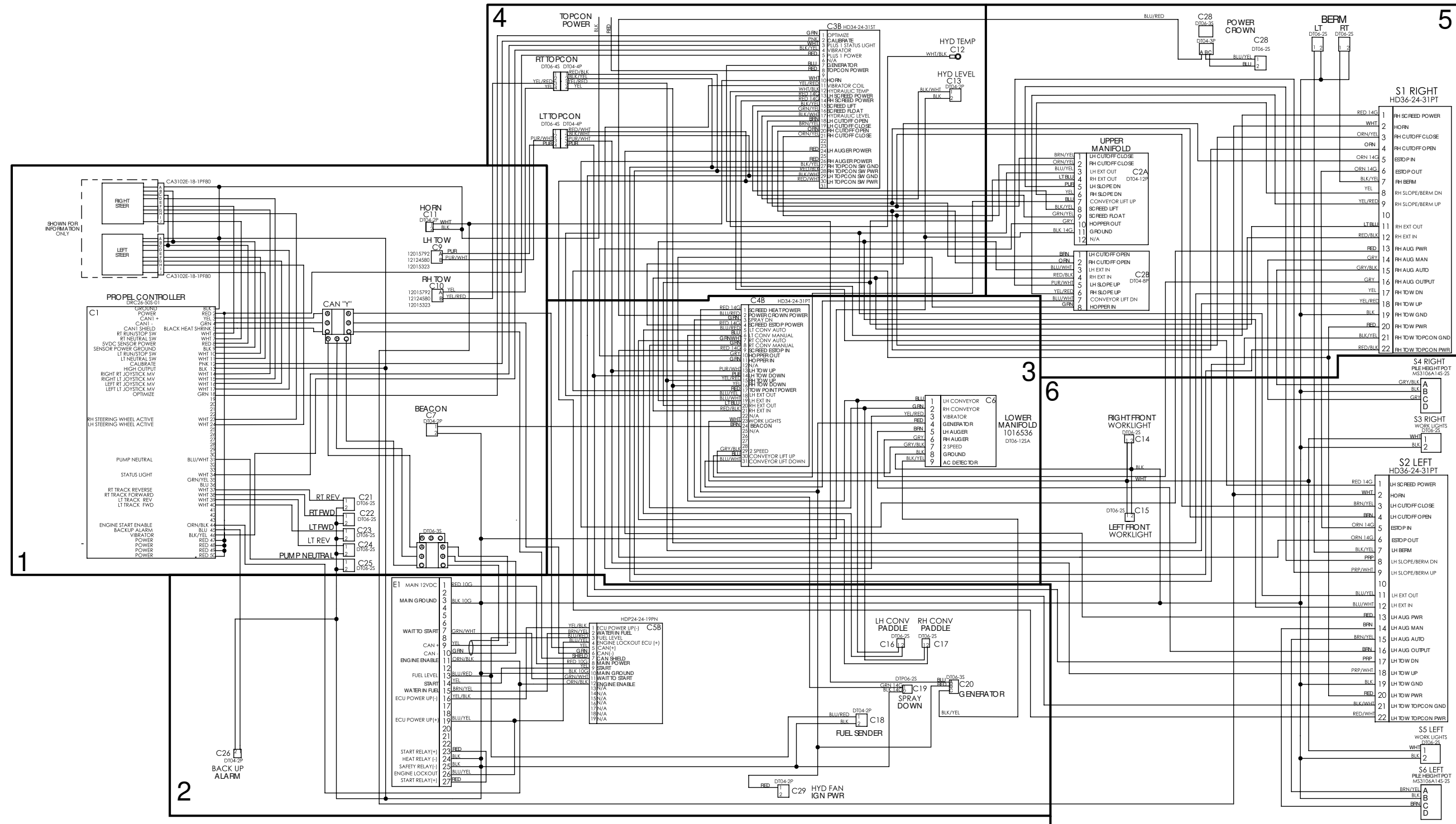

Figure 6-9. Main Harness - 9 Function Screed Control (1 of 8)

NOTES

MAIN HARNESS - 9 FUNCTION SCREED CONTROL (2 OF 8)

Schematic for Part # 1017840

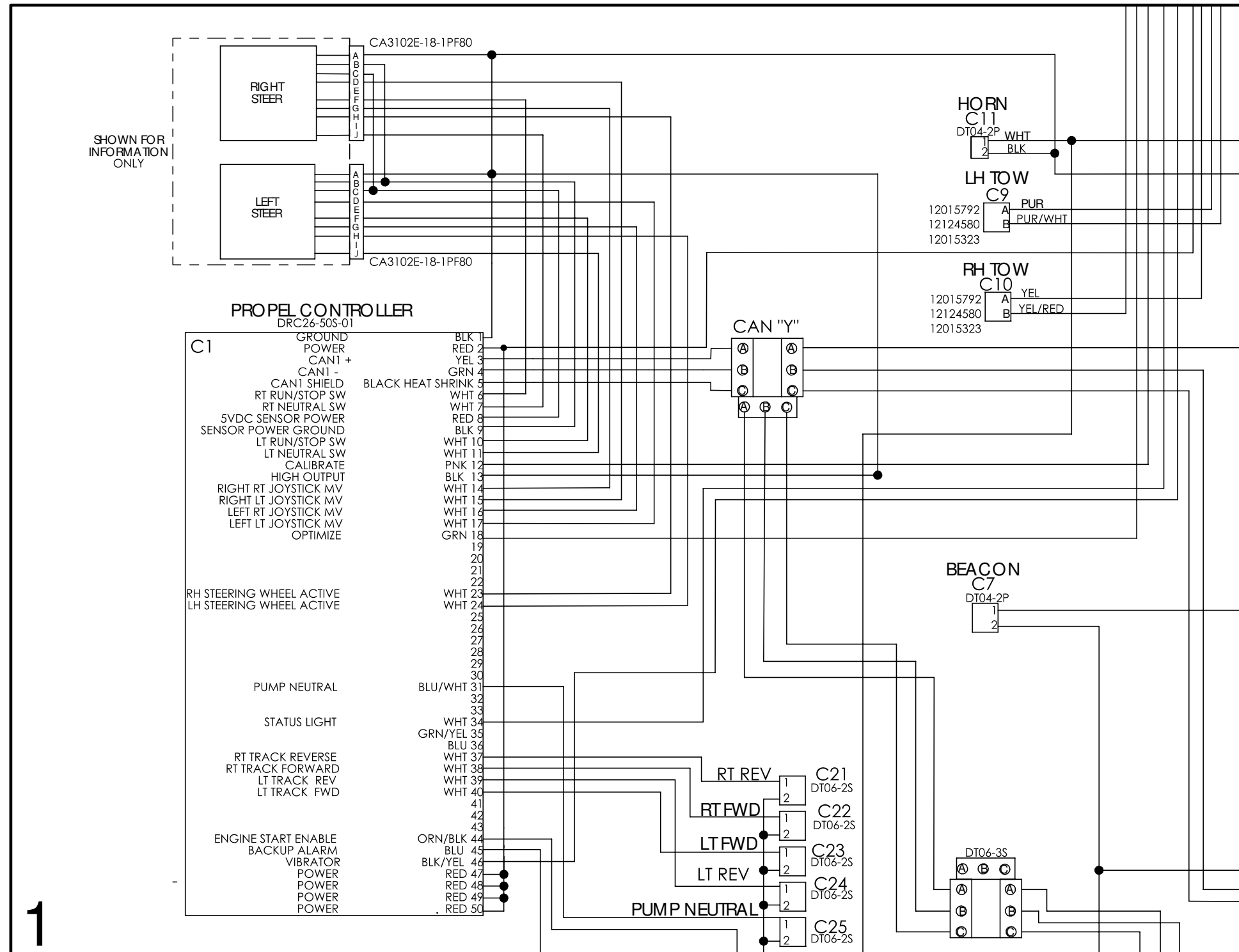

Figure 6-10. Main Harness - 9 Function Screed Control (2 of 8)

NOTES

MAIN HARNESS - 9 FUNCTION SCREED CONTROL (3 OF 8)

Schematic for Part # 1017840

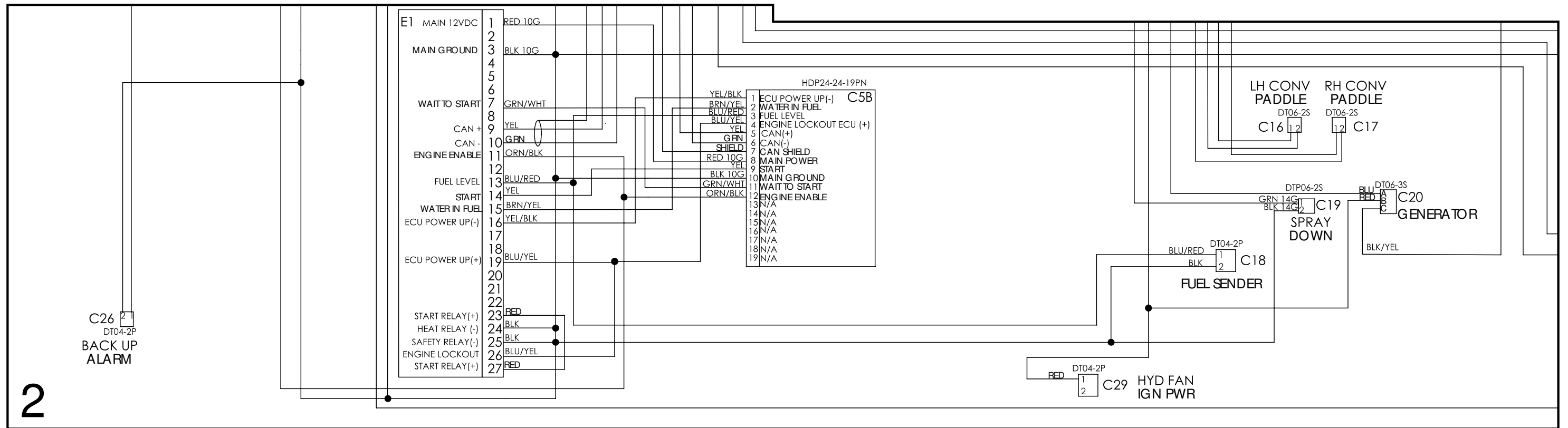

Figure 6-11. Main Harness - 9 Function Screed Control (3 of 8)

NOTES

MAIN HARNESS - 9 FUNCTION SCREED CONTROL (4 OF 8)

Schematic for Part # 1017840

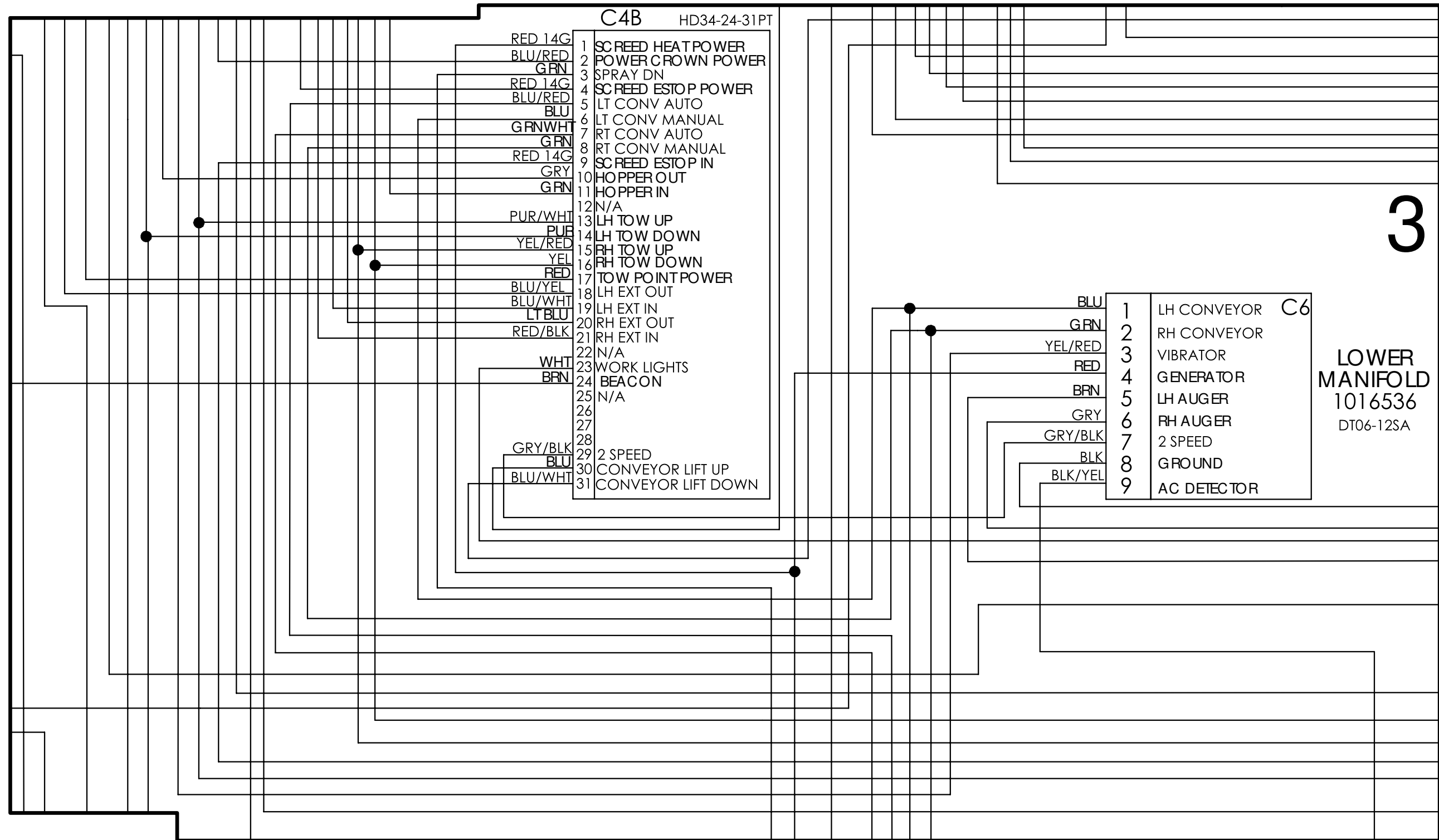

Figure 6-12. Main Harness - 9 Function Screed Control (4 of 8)

NOTES

MAIN HARNESS - 9 FUNCTION SCREED CONTROL (5 OF 8)

Schematic for Part # 1017840

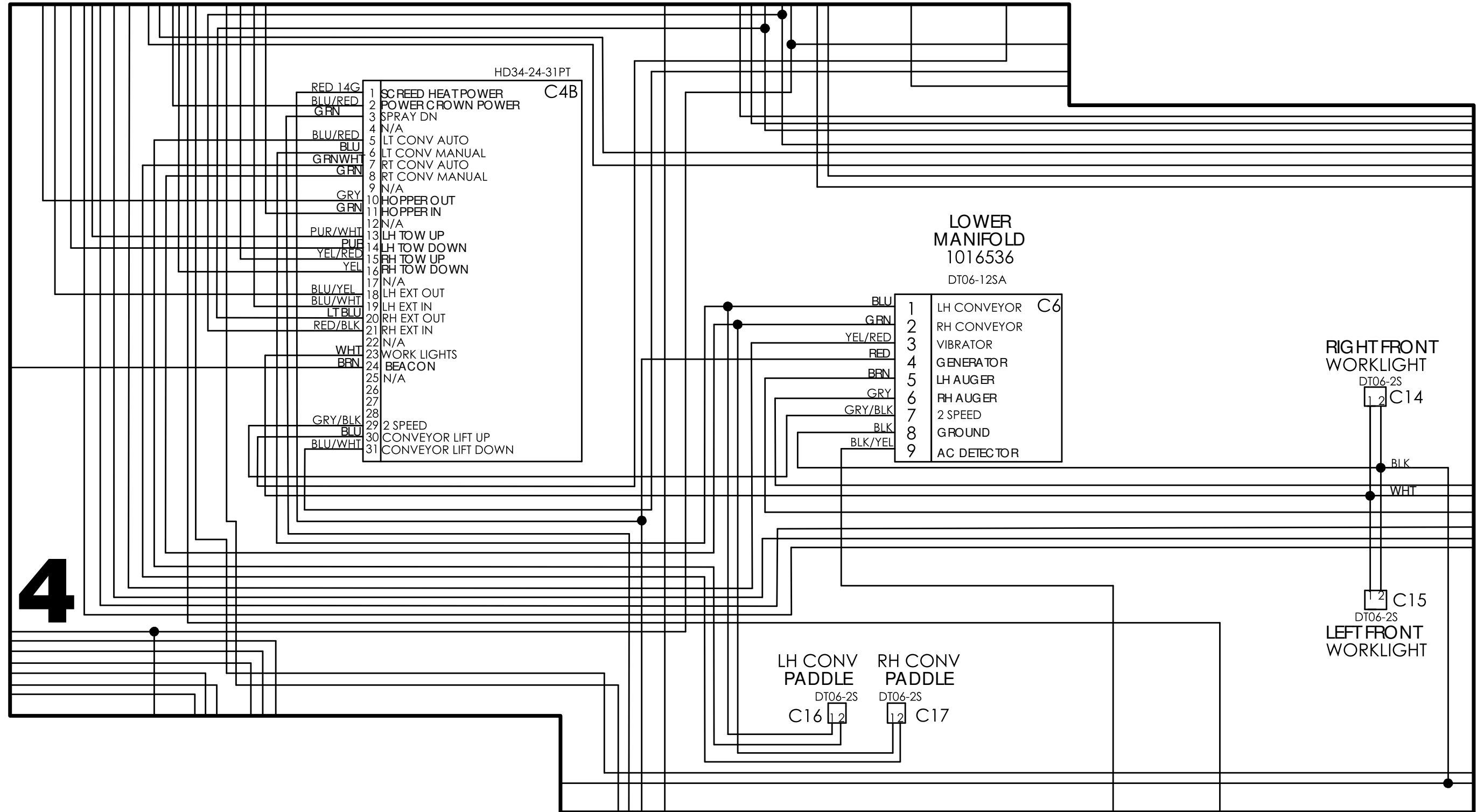
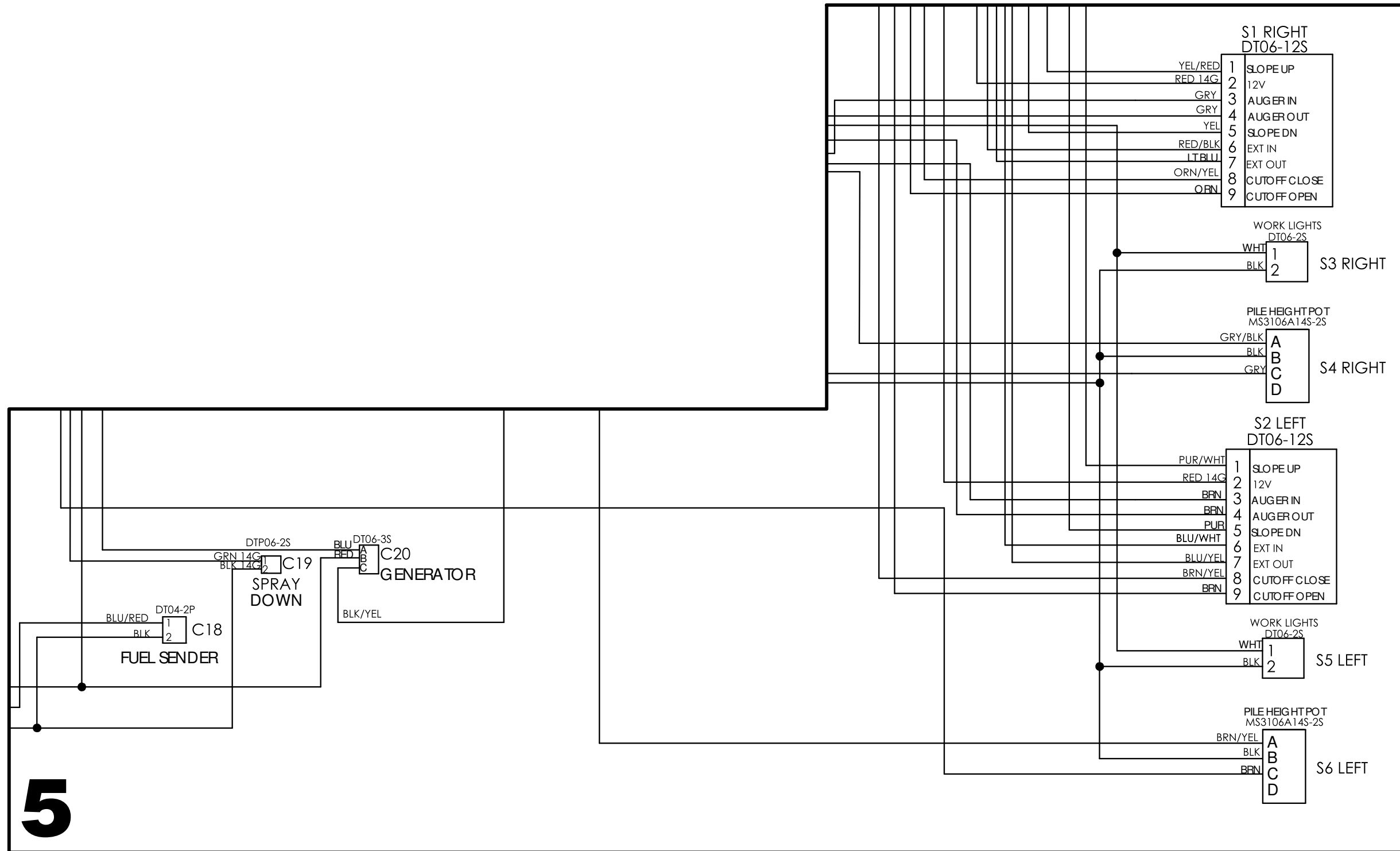

Figure 6-13. Main Harness - 9 Function Screed Control (5 of 8)

NOTES

MAIN HARNESS - 4 FUNCTION SCREED CONTROL (6 OF 8)

Schematic for Part # 1017840



5

6

Figure 6-14. Main Harness - 9 Function Screed Control (6 of 8)

NOTES

MAIN HARNESS - 9 FUNCTION SCREED CONTROL (7 OF 8)

Schematic for Part # 1017840

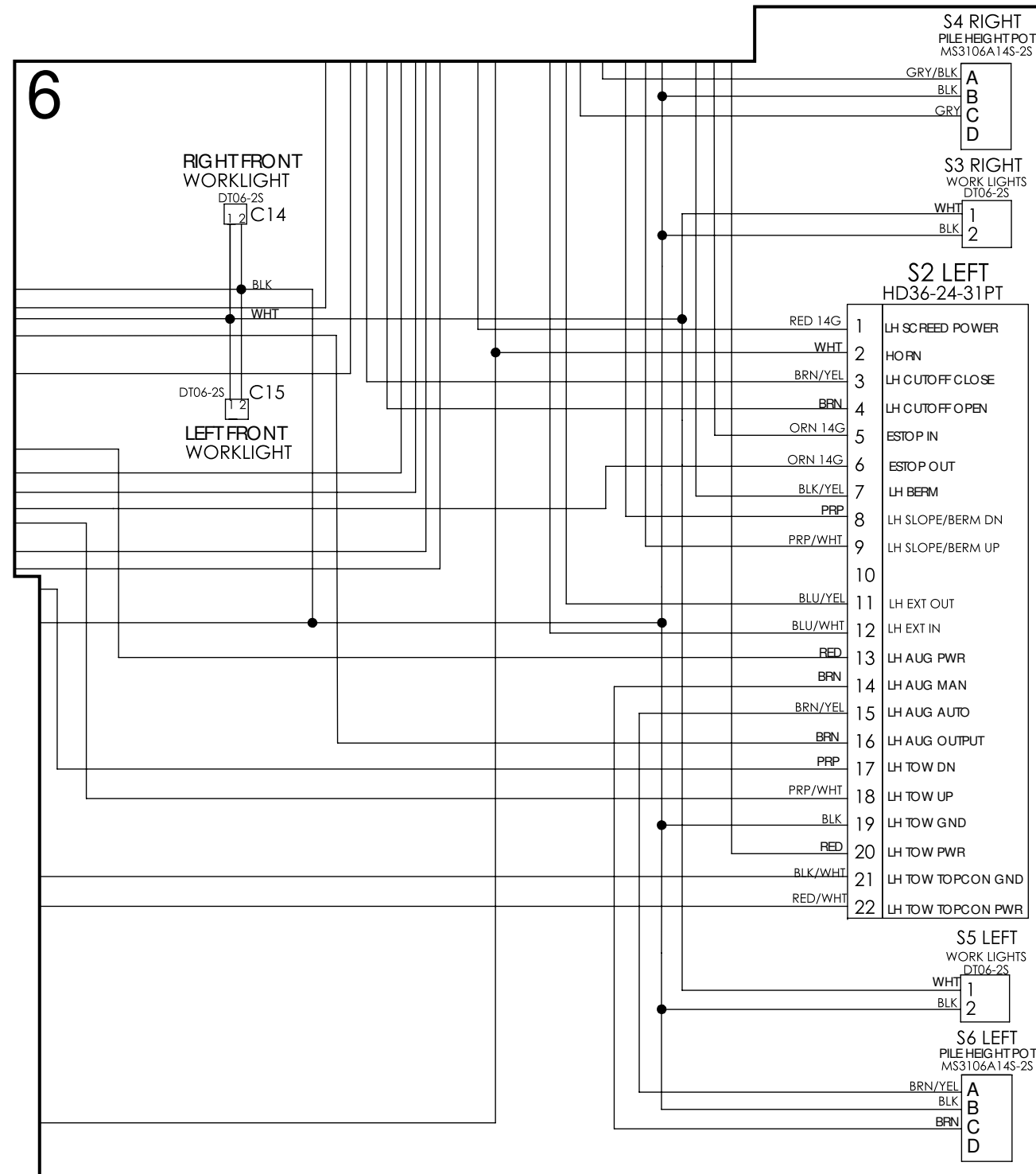

Figure 6-15. Main Harness - 9 Function Screed Control (7 of 8)

NOTES

MAIN HARNESS - 9 FUNCTION SCREED CONTROL (8 OF 8)

Schematic for Part # 1017840

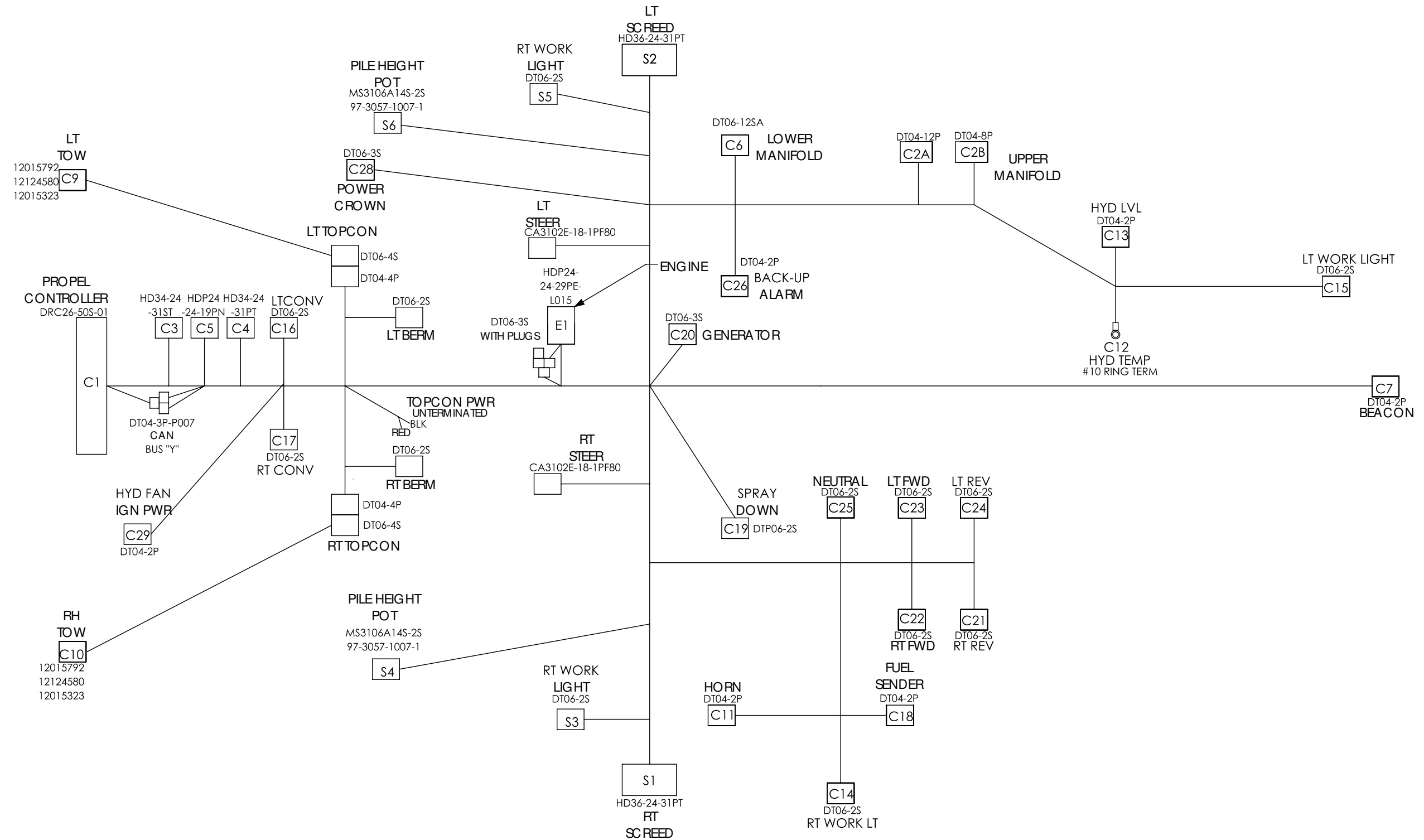
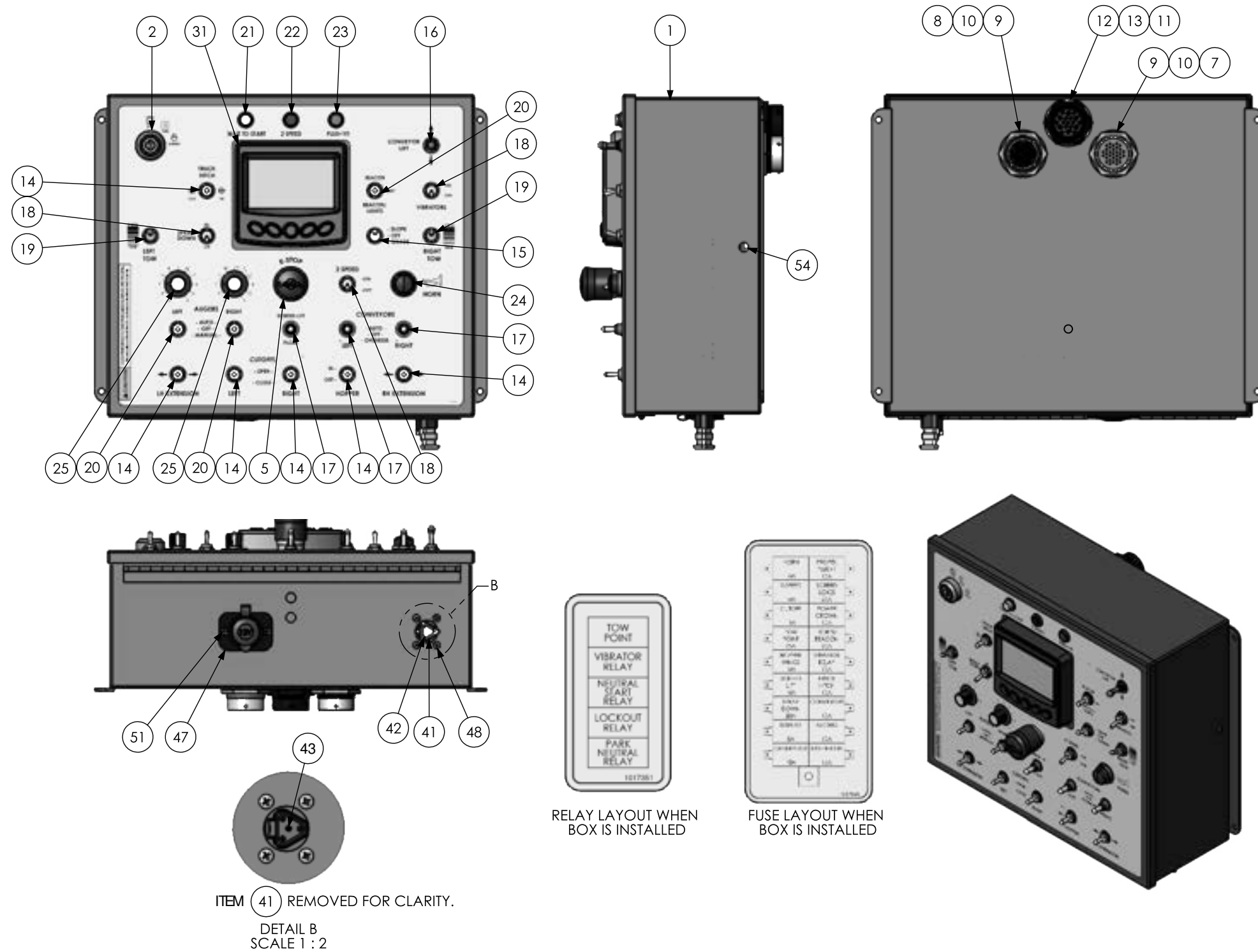

Figure 6-16. Main Harness - 9 Function Screed Control (8 of 8)

NOTES

CONTROL BOX ASSEMBLY - 4 FUNCTION SCREED CONTROL (1 OF 3)

Schematic for Part # 1016576



ITEM NO.	PART NUMBER	QTY	DESCRIPTION
1	1016034-01	1	ENCLOSURE, CONTROL BOX, 150D
2	1016362	1	DECAL, OPER, CONTROL BOX, 8520/8515E
3	1007228-03	1	PANEL, WITH NOTCH, 8616
4	39146-14	1	SWITCH,IGN,W/HEAT ST
5	1010672	1	SWITCH,EMER STOP, 1-NC
6	1010692	1	CONTACT BLOCK, 1-NC, EATON
7	981916	1	CONN,31-PIN,RECPT,HD34-24-31, DEUTSCH
8	1015381	1	CONNECTOR, 31 PIN, HD34-24-31ST
9	981916-02	2	CONN,LOCK WASHER,24 SHELL
10	981916-01	2	CONN,NUT,24 SHELL
11	1014909	1	RECEPTACLE, 19 PIN, DEUTSCH HDP20 SERIES
12	1011855	1	CONNECTOR, WASHER, DEUTSCH HDP20 SERIES
13	1011854	1	CONNECTOR, NUT, DEUTSCH HDP20 SERIES
14	851392	6	SWITCH,TOGGLE,3-POS,SPDT,MOM
15	851390	1	SWITCH,TOGGLE,DPDT,3-POS
16	851393	1	SWITCH,TOGGLE,3-POS,SPDT,MOM LK
17	900030	3	SWITCH,TOGGLE,AUTO CONVEYOR *
18	851391	3	SWITCH,TOGGLE,SPST,2-POS
19	37521	2	SWITCH,TOGGLE,3-POS, 2 POL, MOM
20	851090613	4	SWITCH,TOGGLE,SPDT,3-POS
21	1010500	1	LIGHT,INDICATOR,WHITE
22	31986	1	LIGHT,BLUE,DASH,.50 HOLE
23	31985	1	LIGHT,GREEN,DASH,.50 HOLE
24	982249	1	SWITCH,PUSH BUTTON
25	35049	2	KNOB,.25 SHAFT KNOB
26	36086	5	BRACKET,RELAY MOUNT
27	36085	5	RELAY,12VDC,SPDT,40 AMP,5 PIN
28	685060	1	FUSE BLOCK,18 GANG,ATC
29	20934592	1	RELAY,75 AMP,SPST
30	986546	1	CIRCUIT BREAKER,10A
31	1013632	1	DISPLAY,PV480 FOR 8510, 8515 TIER 4F
32	1016260	1	BRACKET, MOUNT, TOGGLE SWITCH
33	1016261	1	DECAL, OPER, CALIBRATE
34	1010077	2	RHEOSTAT, 35 OHM, 25 WATT
35	36340	11	FUSE,10 AMP,ATC
36	36746	1	FUSE,5 AMP,ATC
37	37303	1	FUSE,25 AMP,ATC
38	36341	2	FUSE,15 AMP,ATC
39	36342	3	FUSE,20 AMP,ATC
40	1010657	1	CONNECTOR, 03-PIN, PANEL MOUNT, DEUTSCH, DT04-3P
41	989179	1	CONNECTOR, 03-PIN, PLUG, W/120 OHM
42	982456	3	PIN, DEUTSCH, 14-16AWG
43	983211	1	CONNECTOR, WEDGELock, DEUTSCH, W3P
44	989178	1	CONNECTOR,03-PIN,SOCKET,Y,DEUTSCH
45	983210	2	CONNECTOR, 03-PIN, WEDGE, PLUG, DEUTSCH
46	1000649	2	CONNECTOR,03-PIN,SOCKET,DT06-3S-EP11
47	1011147	1	LIGHTER, CIGARETTE
48	122-#8-32-8F	8	PHMS, CROSS, #8-32 X 0.5, FT
49	215-#8-32	4	NUT,HEX,MACH,LW,#8-32
50	122-#8-32-4F	2	PHMS, CROSS, #8-32 X 0.25, FT
51	123-#10-24-8F	2	PHMS, CROSS, #10-24 X 0.5, FT
52	215-#10-24	2	NUT,HEX,MACH,LW,#10-24
53	303-#8	2	WASHER, LOCK, EXT TOOTH, #8
54	122-#8-32-16F	4	PHMS, CROSS, #8-32 X 1, FT
55	1017345	1	DECAL, OPER, FUSE DIAGRAM 8515E/8520
56	1017351	1	DECAL, OPER, RELAY DIAGRAM 8515E/8520/150D/6150

Figure 6-17. Control Box Assembly - 4 Function Screed Control (1 of 3)

NOTES

CONTROL BOX ASSEMBLY - 4 FUNCTION SCREED CONTROL (2 OF 3)

Schematic for Part # 1016576

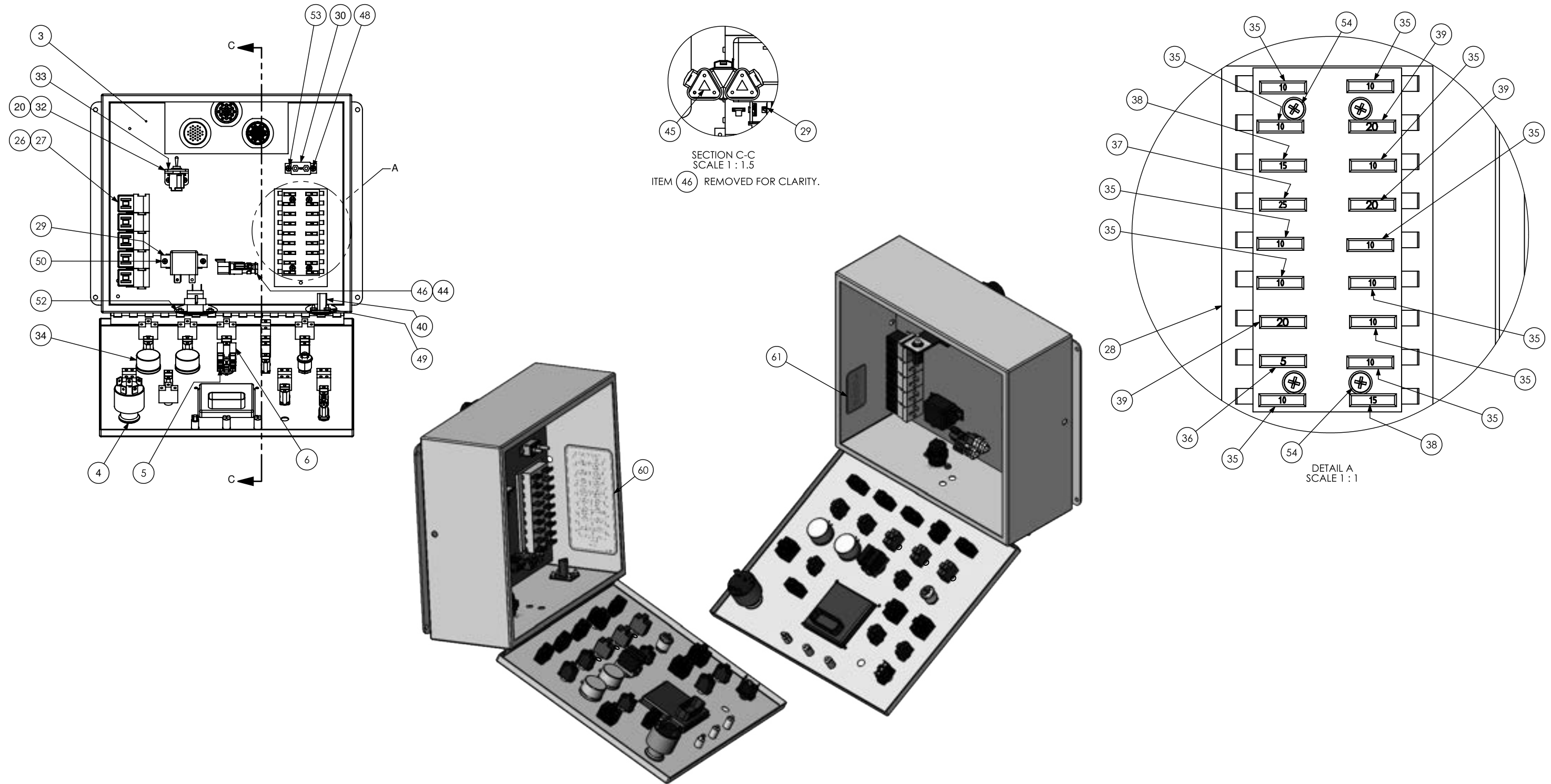

Figure 6-18. Control Box Assembly - 4 Function Screed Control (2 of 3)

NOTES

CONTROL BOX ASSEMBLY - 4 FUNCTION SCREED CONTROL (3 OF 3)

Schematic for Part # 1016576

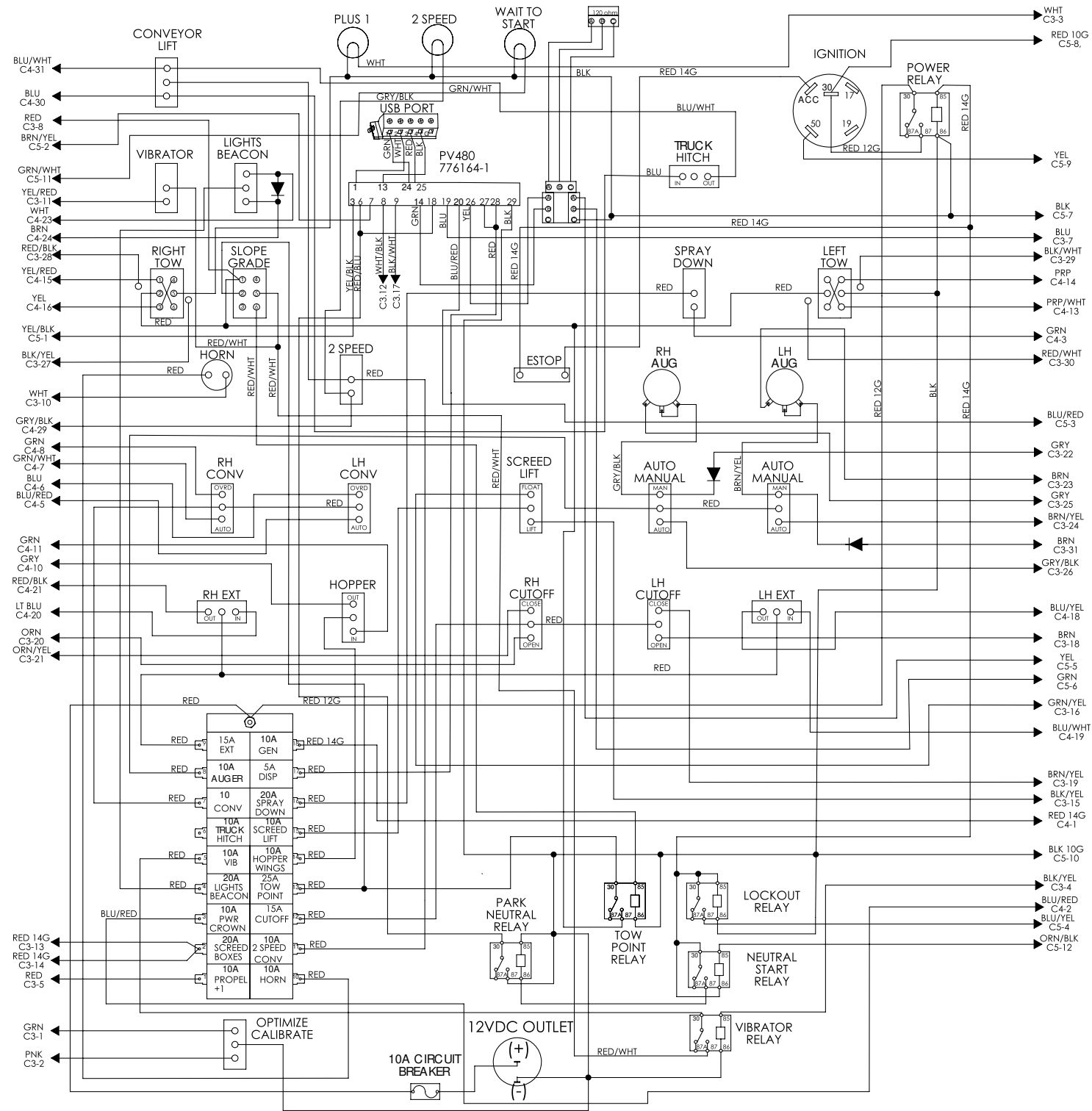

Figure 6-19. Control Box Assembly - 4 Function Screed Control (3 of 3)

C3A
HD34-24-31ST

PIN	COLOR	FUNCTION
1	GRN	OPTIMIZE FROM PLUS1
2	PNK	CALIBRATE FROM PLUS1
3	WHT	PLUS 1 STATUS LIGHT
4	BLK/YEL	PLUS 1 VIBRATOR
5	RED	12V TO PLUS 1
6		
7	BLU	GENERATOR ON INPUT
8	RED	TOPCON POWER
9		
10	WHT	HORN
11	YEL/RED	VIBRATOR COIL
12	WHT/BLK	HYDRAULIC TEMP
13	RED 14G	LH SCREED POWER
14	RED 14G	RH SCREED POWER
15	BLK/YEL	SCREED RAISE
16	GRN/YEL	SCREED FLOAT
17	BLK/WHT	HYDRAULIC LEVEL
18	BRN	LH CUT OFF OPEN
19	BRN/YEL	LH CUTOFF CLOSE
20	ORN	RH CUTOFF OPEN
21	ORN/YEL	RH CUTOFF CLOSE
22	GRY	RH PILE HEIGHT OUT
23	BRN	LH AUGER MAN
24	BRN/YEL	LH AUGER AUTO
25	GRY	RH AUGER MAN
26	GRY/BLK	RH AUGER AUTO
27	BLK/YEL	RH TOPCON SW GND
28	RED/BLK	RH TOPCON SW PWR
29	BLK/WHT	LH TOPCON SW GND
30	RED/WHT	LH TOPCON SW PWR
31	BRN	LH PILE HEIGHT OUT

C4A
HD34-24-31PT

PIN	COLOR	FUNCTION
1	RED 14G	GEN CNTL POWER
2	BLU/RED	12V TO PWR CROWN
3	GRN	SPRAY DN
4		
5	BLU/RED	LH CONV AUTO
6	BLU	LH CONV OVERRIDE
7	GRN/WHT	RH CONV AUTO
8	GRN	RH CONV OVERRIDE
9		
10	GRY	HOPPER OUT
11	GRN	HOPPER IN
12		
13	PUR/WHT	LH TOW UP
14	PUR	LH TOW DN
15	YEL/RED	RH TOW DN
16	YEL	RH TOW UP
17		
18	BLU/YEL	LH EXT OUT
19	BLU/WHT	LH EXT IN
20	LT BLU	RH EXT OUT
21	RED/BLK	RH EXT IN
22		
23	WHT	WORK LIGHTS
24	BRN	BEACON/WORK LTS
25		
26		
27		
28		
29	GRY/BLK	2 SPEED
30	BLU	CONV LIFT UP
31	BLU/WHT	CONV LIFT DN

C5A
HDP24-24-19PN

PIN	COLOR	DESCRIPTION
1	YEL/BLK	480-3 TO CN6E-16 ECU(-)
2	BRN/YEL	480-7 TO CN6E-15 H2O
3	BLU/RED	480-20 TO CN6E-13 FUEL
4	BLU/YEL	LOCKOUT TO CN6E-26
5	YEL	CAN (+)
6	GRN	CAN (-)
7	SHIELD	CAN SHIELD
8	RED 10G	12V FROM E2-1
9	YEL	KS 50 TO CN6E-14
10	BLK 10G	GND FROM E2-3
11	GRN/WHT	WAIT TO START
12	ORN/BLK	ENGINE ENABLE
13	N/A	
14	N/A	
15		
16	N/A	
17		
18	N/A	
19		

NOTES

CONTROL BOX ASSEMBLY - 9 FUNCTION SCREED CONTROL (1 OF 3)

Schematic for Part # 1018700

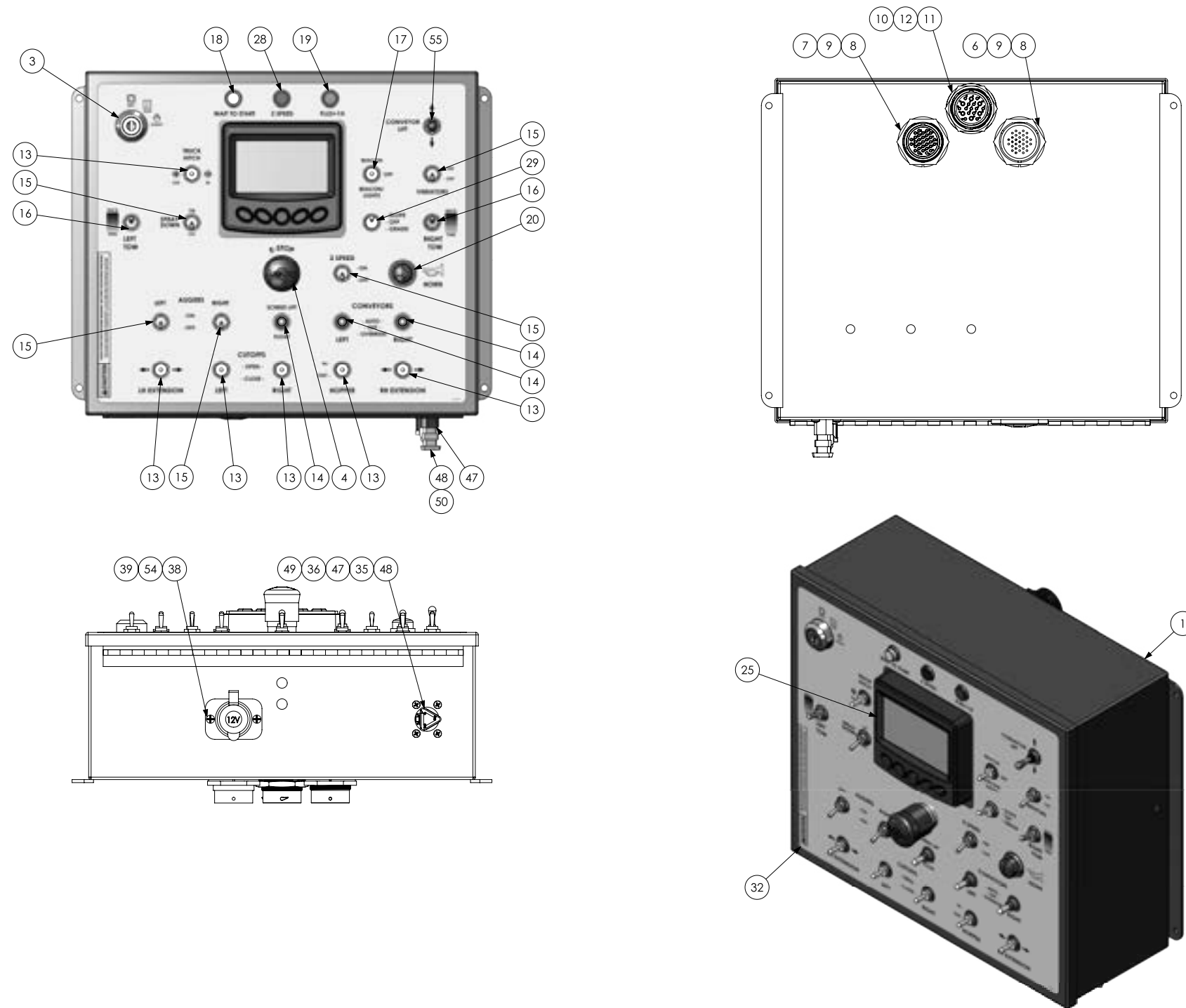

ITEM NO.	PARTNUMBER	QTY	DESCRIPTION
1	1017810	1	ENCLOSURE, CONTROL BOX, 8520, 8515E, 6150/150D
2	1007228-03	1	PANEL, WITH NOTCH, 8616
3	39146-14	1	SWITCH,IGN,W/HEAT ST
4	1010672	1	SWITCH,EMER STOP, 1-NC
5	1010692	1	CONTACT BLOCK, 1-NC, EATON
6	981916	1	CONN,31-PIN,RECPT,HD34-24-31, DEUTSCH
7	1015381	1	CONNECTOR, 31 PIN, HD34-24-31ST
8	981916-02	2	CONN,LOCK WASHER,24 SHELL
9	981916-01	2	CONN,NUT,24 SHELL
10	1014909	1	RECEPTACLE, 19 PIN, DEUTSCH HDP20 SERIES
11	1011855	1	CONNECTOR, WASHER, DEUTSCH HDP20 SERIES
12	1011854	1	CONNECTOR, NUT, DEUTSCH HDP20 SERIES
13	851392	6	SWITCH,TOGGLE,3-POS,SPDT,MOM
14	900030	3	SWITCH,TOGGLE,AUTO CONVEYOR *
15	851391	5	SWITCH,TOGGLE,SPST,2-POS
16	37521	2	SWITCH,TOGGLE,3-POS, 2 POL, MOM
17	851090613	2	SWITCH,TOGGLE,SPDT,3-POS
18	1010500	1	LIGHT,INDICATOR, WHITE
19	31985	1	LIGHT,GREEN,DASH,.50 HOLE
20	982249	1	SWITCH,PUSH BUTTION
21	36086	3	BRACKET,RELAY MOUNT
22	36085	3	RELAY,12VDC,SPDT,40 AMP,5 PIN
23	20934592	1	RELAY,75 AMP,SPST
24	986546	1	CIRCUIT BREAKER,10A
25	1016158	1	DISPLAY, PV480, V3874 T4F
26	1016260	1	BRACKET, MOUNT, TOGGLE SWITCH
27	1016261	1	DECAL, OPER, CALIBRATE
28	31986	1	LIGHT,BLUE,DASH,.50 HOLE
29	851390	1	SWITCH,TOGGLE,DPDT,3-POS
30	1017351	1	DECAL, OPER, RELAY DIAGRAM 8515E/8520/150D/6150
31	1017345	1	DECAL, OPER, FUSE DIAGRAM 8515E/8520
32	1017811	1	DECAL, OPER, CONTROL BOX, 8520/8515E
33	1013122	1	CONNECTOR, 35 POS, AMP SEAL PLUG, BLACK
34	685060	1	FUSE BLOCK,18 GANG,ATC
35	122-#8-32-8F	4	PHMS, CROSS, #8-32 X 0.5, FT
36	215-#8-32	4	NUT,HEX,MACH,LW,#8-32
37	122-#8-32-6F	6	PHMS, CROSS, #8-32 X 0.375, FT
38	123-#10-24-8F	2	PHMS, CROSS, #10-24 X 0.5, FT
39	215-#10-24	2	NUT,HEX,MACH,LW,#10-24
40	303-#8	2	WASHER, LOCK, EXT TOOTH, #8
41	122-#8-32-16F	4	PHMS, CROSS, #8-32 X 1, FT
42	36342	3	FUSE,20 AMP,ATC
43	36340	11	FUSE,10 AMP,ATC
44	36746	1	FUSE,5 AMP,ATC
45	37303	1	FUSE,25 AMP,ATC
46	36341	2	FUSE,15 AMP,ATC
47	1010657	1	CONNECTOR, 03-PIN, PANEL MOUNT, DEUTSCH, DT04-3P
48	989179	1	CONNECTOR, 03-PIN, PLUG, W/120 OHM
49	982456	3	PIN, DEUTSCH, 14-16AWG
50	983211	1	CONNECTOR, WEDGELOCK, DEUTSCH, W3P
51	989178	1	CONNECTOR,03-PIN, SOCKET,Y,DEUTSCH
52	983210	2	CONNECTOR, 03-PIN, WEDGE, PLUG, DEUTSCH
53	1000649	2	CONNECTOR,03-PIN, SOCKET,DT06-3S-EP11
54	1011147	1	LIGHTER, CIGARETTE
55	851393	1	SWITCH,TOGGLE,3-POS,SPDT,MOM LK
56	35044	2	DIODE, 3 AMP, PLASTIC, 1N5402

Figure 6-20. Control Box Assembly - 9 Function Screed Control (1 of 3)

NOTES

CONTROL BOX ASSEMBLY - 9 FUNCTION SCREED CONTROL (2 OF 3)

Schematic for Part # 1018700

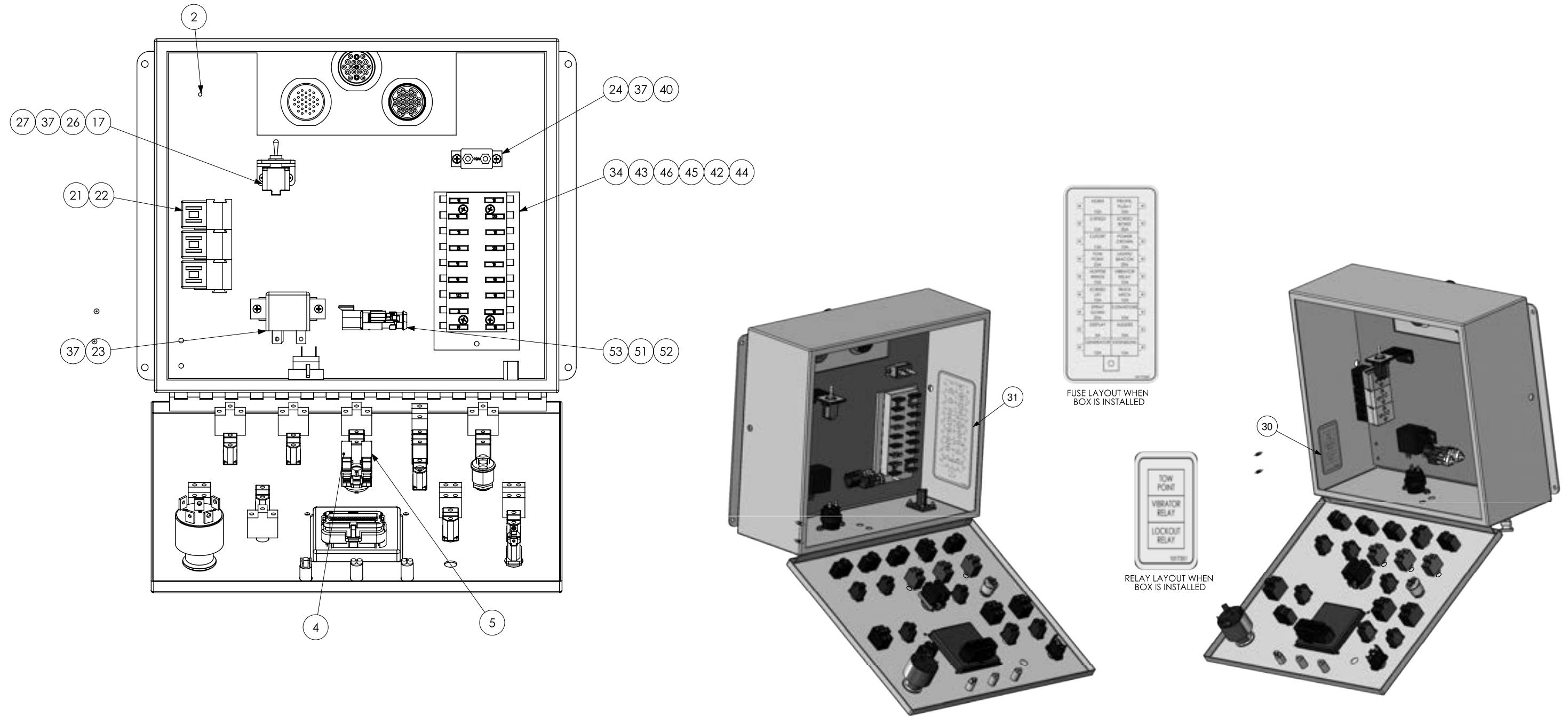
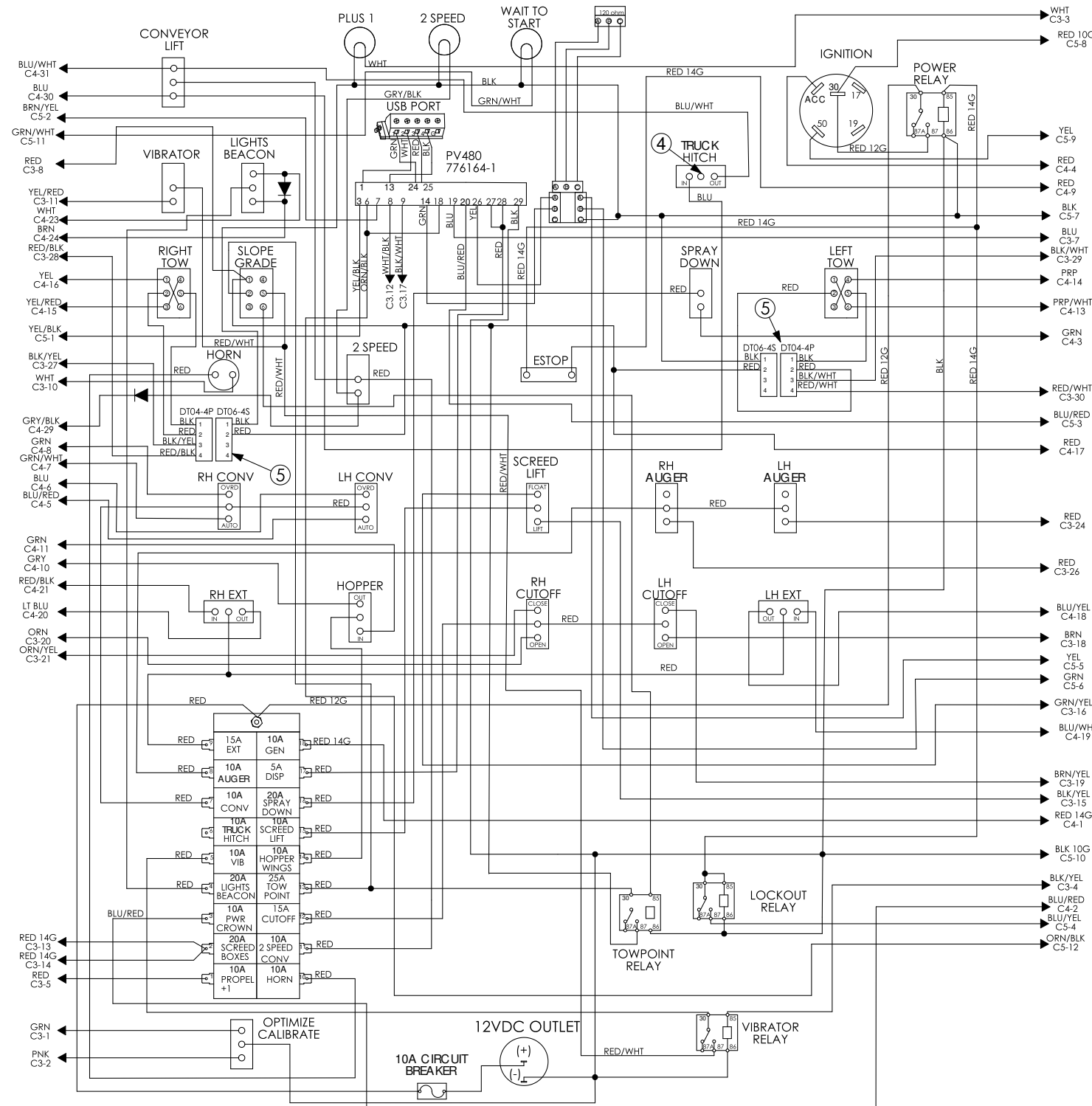

Figure 6-21. Control Box Assembly - 9 Function Screed Control (2 of 3)

NOTES

CONTROL BOX ASSEMBLY - 9 FUNCTION SCREED CONTROL (3 OF 3)

Schematic for Part # 1018700



C3A
HD34-24-31ST

PIN	COLOR	FUNCTION
1	GRN	OPTIMIZE FROM PLUS1
2	PNK	CALIBRATE FROM PLUS1
3	WHT	PLUS 1 STATUS LIGHT
4	BLK/YEL	PLUS 1 VIBRATOR
5	RED	12V TO PLUS 1
6		
7	BLU	GENERATOR ON INPUT
8	RED	TOPCON POWER
9		
10	WHT	HORN
11	YEL/RED	VIBRATOR COIL
12	WHT/BLK	HYDRAULIC TEMP
13	RED 14G	LH SCREED POWER
14	RED 14G	RH SCREED POWER
15	BLK/YEL	SCREED RAISE
16	GRN/YEL	SCREED FLOAT
17	BLK/WHT	HYDRAULIC LEVEL
18	BRN	LH CUTOFF OPEN
19	BRN/YEL	LH CUTOFF CLOSE
20	ORN	RH CUTOFF OPEN
21	ORN/YEL	RH CUTOFF CLOSE
22		
23		
24	RED	LH AUGER PWR
25		
26	RED	RH AUGER PWR
27	BLK/YEL	RH TOPCON SW GND
28	RED/BLK	RH TOPCON SW PWR
29	BLK/WHT	LH TOPCON SW GND
30	RED/WHT	LH TOPCON SW PWR
31		

C4A
HD34-24-31PT

PIN	COLOR	FUNCTION
1	RED 14G	GEN CNTL POWER
2	BLU/RED	12V TO PWR CROWN
3	GRN	SPRAY DN
4	RED 14G	SCREED ESTOP PWR
5	BLU/RED	LH CONV AUTO
6	BLU	LH CONV OVERRIDE
7	GRN/WHT	RH CONV AUTO
8	GRN	RH CONV OVERRIDE
9	RED 14G	SCREED ESTOP IN
10	GRY	HOPPER OUT
11	GRN	HOPPER IN
12		
13	PUR/WHT	LH TOW UP
14	PUR	LH TOW DN
15	YEL/RED	RH TOW UP
16	YEL	RH TOW DN
17	RED	TOW POINT POWER
18	BLU/YEL	LH EXT OUT
19	BLU/WHT	LH EXT IN
20	LT BLU	RH EXT OUT
21	RED/BLK	RH EXT IN
22		
23	WHT	WORK LIGHTS
24	BRN	BEACON/WORK LTS
25		
26		
27		
28		
29	GRY/BLK	2 SPEED
30	BLU	CONV LIFT UP
31	BLU/WHT	CONV LIFT DN

C5A
HDP24-24-19PN

PIN	COLOR	DESCRIPTION
1	YEL/BLK	480-3 TO CN6E-16 ECU(-)
2	BRN/YEL	480-7 TO CN6E-15 H2O
3	BLU/RED	480-20 TO CN6E-13 FUEL
4	BLU/YEL	LOCKOUT TO CN6E-26
5	YEL	CAN (+)
6	GRN	CAN (-)
7	SHIELD	CAN SHIELD
8	RED 10G	12V FROM E2-1
9	YEL	KS 50 TO CN6E-14
10	BLK 10G	GND FROM E2-3
11	GRN/WHT	WAIT TO START
12	ORN/BLK	ENGINE ENABLE
13	N/A	
14	N/A	
15		
16	N/A	
17		
18	N/A	
19		

Figure 6-22. Control Box Assembly - 9 Function Screed Control (3 of 3)

NOTES

C4 DASH TO PEDESTAL JUMPER HARNESS

Schematic for Part # 1016263

C4A & C4B

PIN	COLOR	FUNCTION
1	RED 14G	12V TO SCREED HEAT
2	BLU/RED	12V TO POWER CROWN
3	GRN	SPRAY DN
4		
5	BLU/RED	LH CONV AUTO
6	BLU	LH CONV OVERRIDE
7	GRN/WHT	RH CONV AUTO
8	GRN	RH CONV OVERRIDE
9		
10	GRY	HOPPER OUT
11	GRN	HOPPER IN
12		
13	PRP/WHT	LH TOW UP
14	PRP	LH TOW DN
15	YEL/RED	RH TOW UP
16	YEL	RH TOW DN
17		
18	BLU/YEL	LH EXT OUT
19	BLU/WHT	LH EXT IN
20	LTBLU	RH EXT OUT
21	RED/BLK	RH EXT IN
22		
23	WHT	WORK LIGHTS
24	BRN	BEACON/WORKLIGHTS
25		
26	PRP	PIVOT LEFT
27	PRP/WHT	PIVOT RIGHT
28	YEL/BLK	POSTRAC
29	GRY/BLK	2 SPEED
30	BLU	CONV LIFT UP
31	BLU/WHT	CONV LIFT DN

HD36-24-31ST

HD36-24-31ST

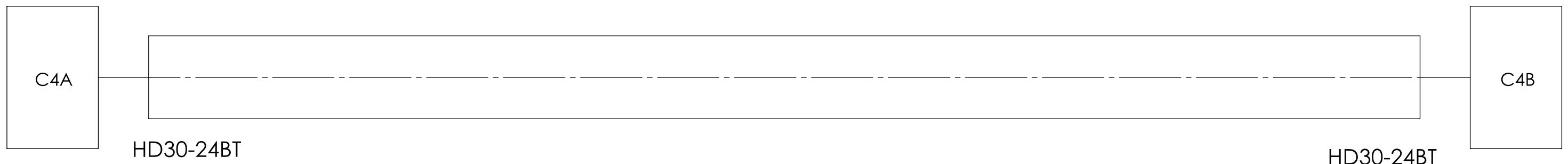

Figure 6-23. C4 Dash to Pedestal Jumper Harness

NOTES

C3 DASH TO PEDESTAL JUMPER HARNESS

Schematic for Part # 1016264

C3A & C3B

PIN	COLOR	FUNCTION
1	WHT	OPTIMIZE FROM PLUS 1
2	WHT	CALIBRATE FROM PLUS 1
3	WHT	PLUS 1 STATUS LIGHT
4	BLK/YEL	PLUS 1 VIBRATOR
5	RED	12V TO PLUS 1
6	WHT	ENGINE ENABLE
7	BLU	GENERATOR ON INPUT
8	YEL	TRUCK HITCH IN
9	YEL/RED	TRUCK HITCH OUT
10	WHT	HORN
11	YEL/RED	VIBRATOR COIL
12	BLK	TOPCON GROUND
13	RED 14G	LH SCREED POWER
14	RED 14G	RH SCREED POWER
15	BLK/YEL	SCREED LIFT
16	GRN YEL	SCREED FLOAT
17	RED	TOPCON POWER
18	BRN	LH CUTOFF OPEN
19	BRN/YEL	LH CUTOFF CLOSE
20	ORN	RH CUTOFF OPEN
21	ORN/YEL	RH CUTOFF CLOSE
22	GRY	RH PILE HEIGHT OUT
23	BRN	LH AUGER MAN
24	BRN/YEL	LH AUGER AUTO
25	GRY	RH AUGER MAN
26	GRY/BLK	RH AUGER AUTO
27	PRP/WHT	LH TOPCON
28	PRP	LH TOPCON
29	YEL/RED	RH TOPCON
30	YEL	RH TOPCON
31	BRN	LH PILE HEIGHT OUT

C5A & C5B

PIN	COLOR	FUNCTION
1	YEL/BLK	480-3 TO CN6E-16 ECU(-)
2	BRN/YEL	480-7 TO CN6E-15 H2O
3	BLU/RED	480-20 TO CN6E-13 FUEL
4	BLU/YEL	LOCKOUT TO CN6E-26
5	YEL	CAN (+)
6	GRN	CAN (-)
7	SHIELD	CAN SHIELD
8	RED 10G	12V FROM E2-1
9	YEL	KS 50 TO CN6E-14
10	BLK 10G	GND FROM E2-3
11	GRN/WHT	WAIT TO START
12	ORN/BLK	ENGINE ENABLE
13		
14		
15		
16		
17		
18		
19		

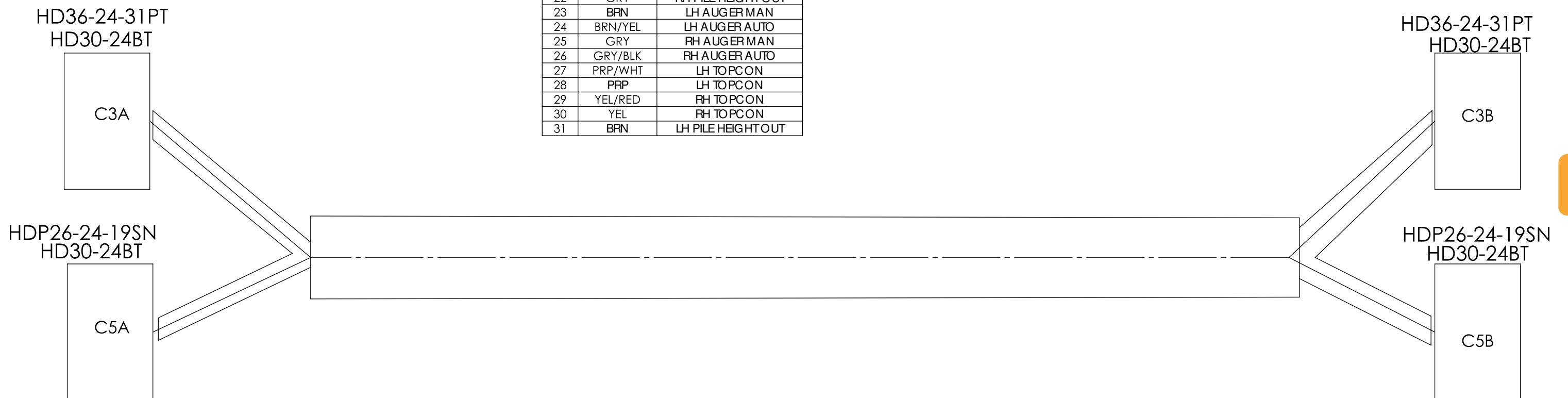

Figure 6-24. C3 Dash to Pedestal Jumper Harness

NOTES

SCREED CONTROL BOX ASSEMBLY, 4 FUNCTION - LEFT

Schematic for Part # 1016618

ITEM NO.	PART NUMBER	QTY	DESCRIPTION
1	1016101-01	1	ENCLOSURE, CONTROL BOX, SCREED, 4 SWITCH, RH
2	1016248	1	DECAL, SCREED CONTROL BOX, RH
3	851391	1	SWITCH, TOGGLE, SPST, 2-POS
4	851392	2	SWITCH, TOGGLE, 3-POS, SPDT, MOM
5	851393	1	SWITCH, TOGGLE, 3-POS, SPDT, MOM LK
6	3400DI	1	WATER TIGHT CONN, 3/4 X 3/4 MPT

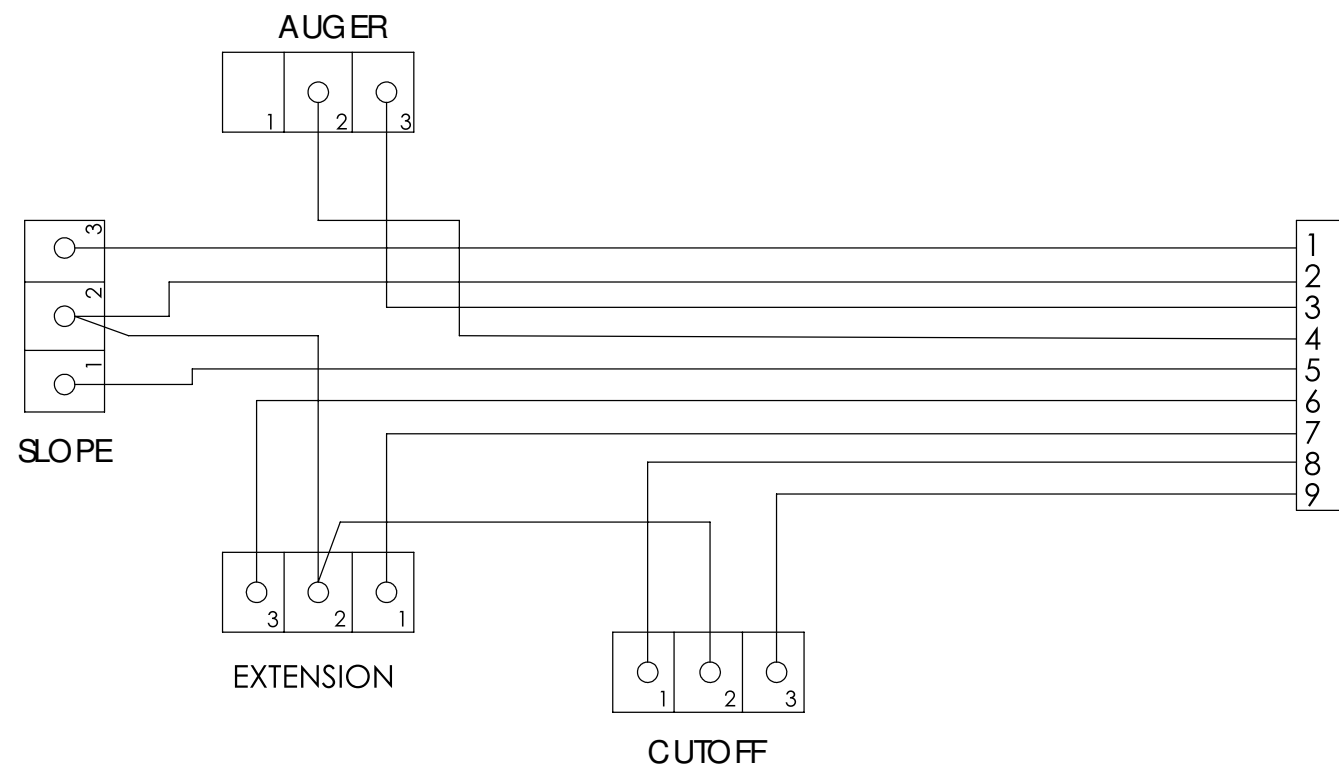

DT04-12P		
1	WHT/BLK	SLOPE RAISE
2	RED	POWER
3	GRN	AUGER ON
4	WHT	AUGER POWER
5	ORG	SLOPE LOWER
6	BLU	EXT IN
7	BLK	EXT OUT
8	PRP	CUTOFF CLOSE
9	BRN	CUTOFF OPEN

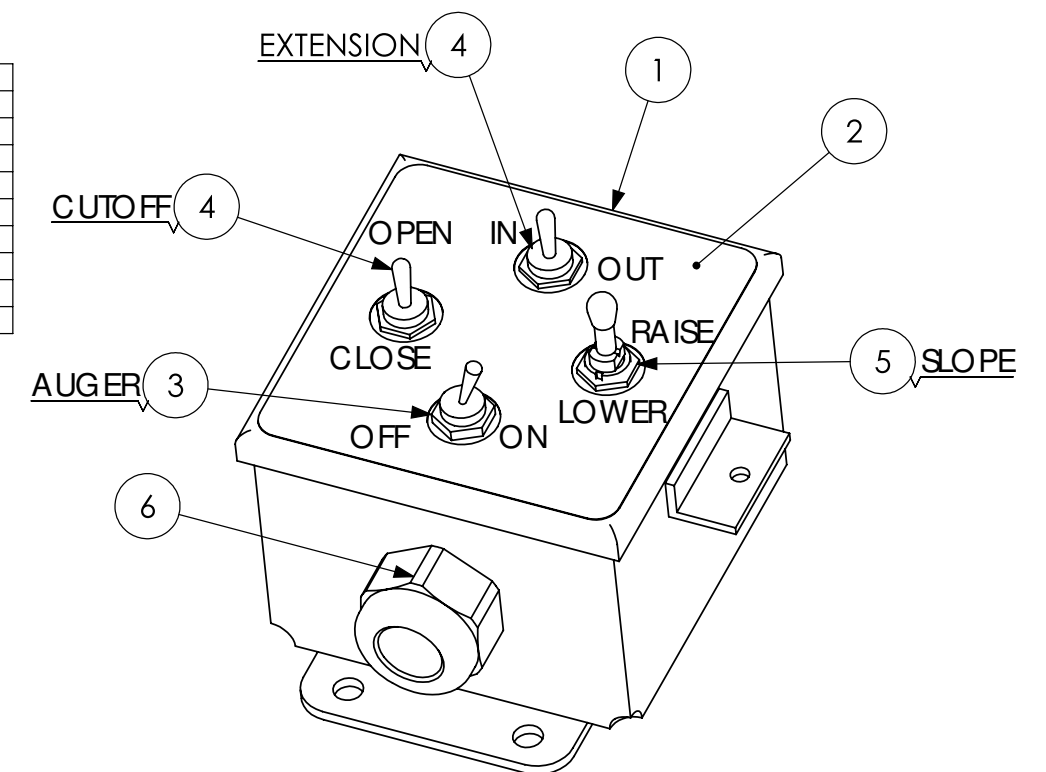

Figure 6-25. Screed Control Box Assembly, 4 Function - Left

NOTES

SCREED CONTROL BOX ASSEMBLY, 4 FUNCTION - RIGHT

Schematic for Part # 1016617

ITEM NO.	PART NUMBER	QTY	DESCRIPTION
1	1016101-01	1	ENCLOSURE, CONTROL BOX, SCREED, 4 SWITCH, RH
2	1016248	1	DECAL, SCREED CONTROL BOX, RH
3	851391	1	SWITCH, TOGGLE, SPST, 2-POS
4	851392	2	SWITCH, TOGGLE, 3-POS, SPDT, MOM
5	851393	1	SWITCH, TOGGLE, 3-POS, SPDT, MOM LK
6	3400DI	1	WATER TIGHT CONN, 3/4 X 3/4 MPT

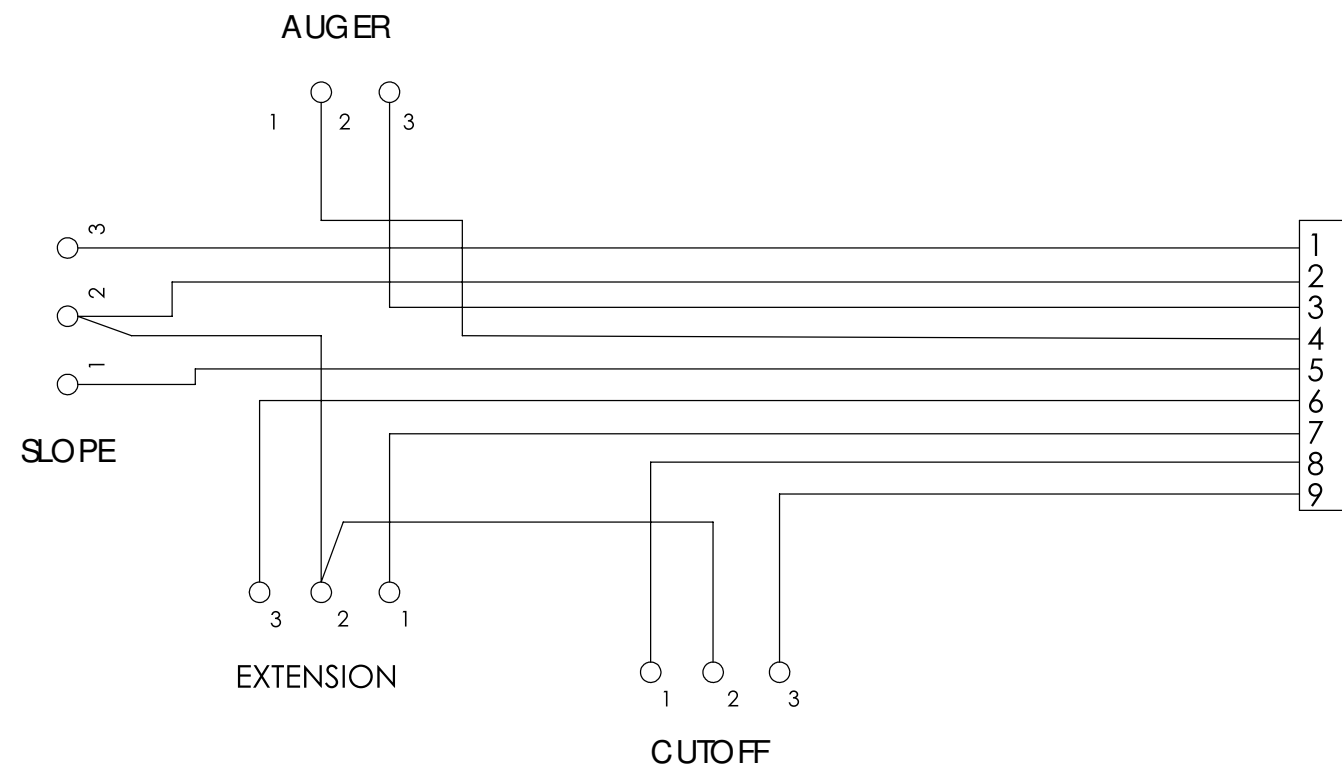

DT04-12P		
1	WHT/BLK	SLOPE RAISE
2	RED	POWER
3	GRN	AUGER ON
4	WHT	AUGER POWER
5	ORG	SLOPE LOWER
6	BLU	EXT IN
7	BLK	EXT OUT
8	PRP	CUTOFF CLOSE
9	BRN	CUTOFF OPEN

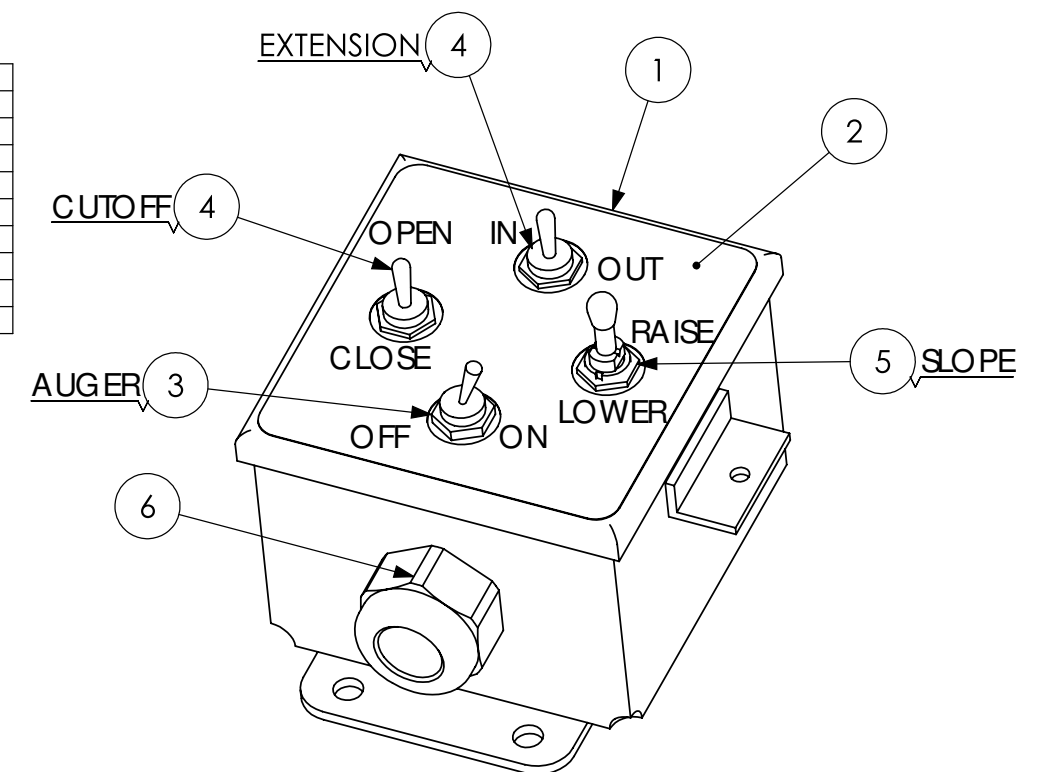
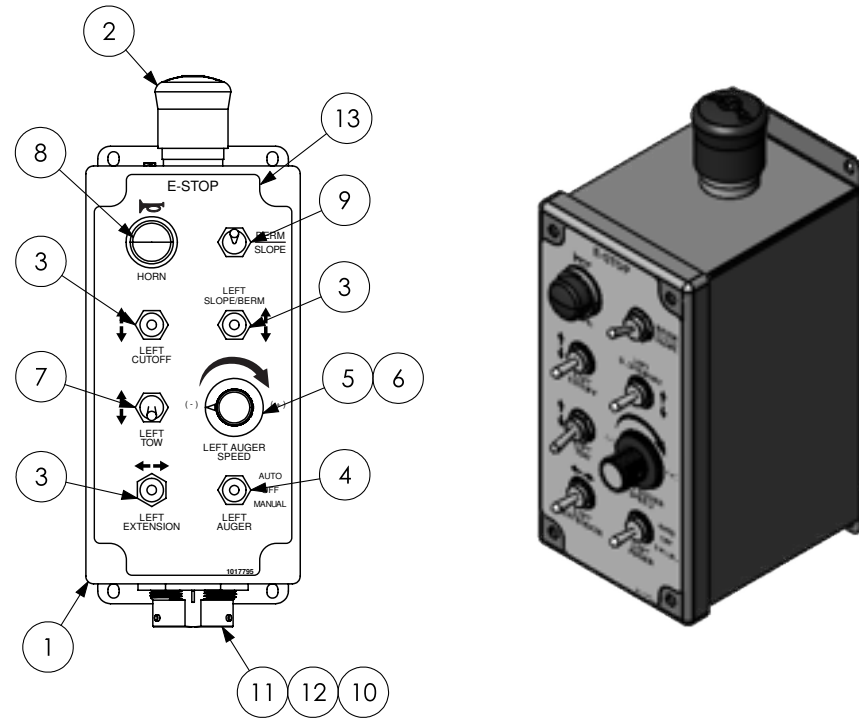

Figure 6-26. Screed Control Box Assembly, 4 Function - Right

NOTES

SCREED CONTROL BOX ASSEMBLY, 9 FUNCTION - LEFT

Schematic for Part # 1017791



ITEM NO.	PARTNUMBER	QTY	DESCRIPTION
1	1017793	1	ENCLOSURE, SCREED CONTROL, WITH HOLES
2	1010672	1	SWITCH,EMER STOP, 1-NC
3	851392	3	SWITCH,TOGGLE,3-POS,SPDT,MOM
4	851090613	1	SWITCH,TOGGLE,SPDT,3-POS
5	35049	1	KNOB,.25 SHAFT KNOB
6	1010077	1	RHEOSTAT, 35 OHM, 25 WATT
7	37521	1	SWITCH,TOGGLE,3-POS, 2 POL, MOM
8	982249	1	SWITCH,PUSH BUTTON
9	851391	1	SWITCH,TOGGLE,SPST,2-POS
10	1015381	1	CONNECTOR, 31 PIN, HD34-24-31ST
11	981916-02	1	CONN,LOCK WASHER,24 SHELL
12	981916-01	1	CONN,NUT,24 SHELL
13	1017795	1	DECAL, SCREED CONTROL, LH, 815HD

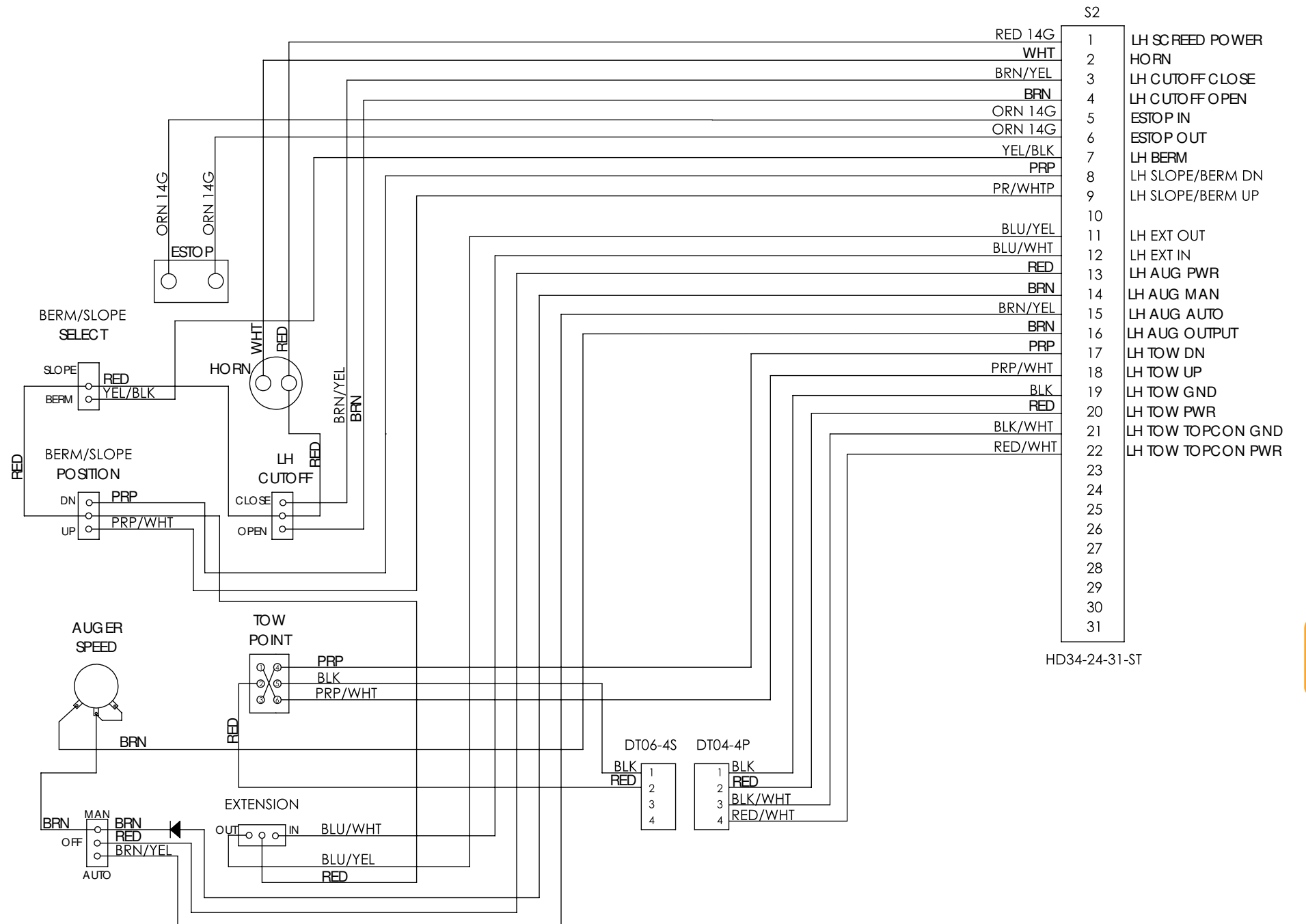
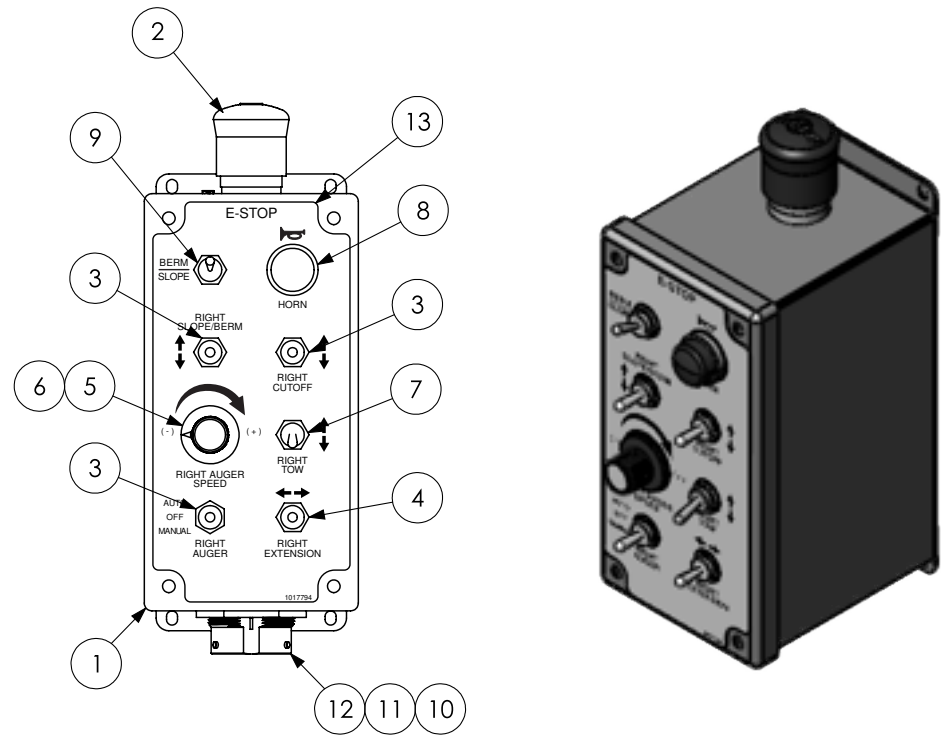

Figure 6-27. Screed Control Box Assembly, 9 Function - Left

NOTES

SCREED CONTROL BOX ASSEMBLY, 9 FUNCTION - RIGHT

Schematic for Part # 1017792



ITEM NO.	PART NUMBER	QTY	DESCRIPTION
1	1017822	1	ENCLOSURE, SCREED CONTROL, WITH HOLES
2	1010672	1	SWITCH,EMER STOP, 1-NC
3	851392	3	SWITCH,TOGGLE,3-POS,SPDT,MOM
4	851090613	1	SWITCH,TOGGLE,SPDT,3-POS
5	35049	1	KNOB,.25 SHAFT KNOB
6	1010077	1	RHEOSTAT, 35 OHM, 25 WATT
7	37521	1	SWITCH,TOGGLE,3-POS, 2 POL, MOM
8	982249	1	SWITCH,PUSH BUTTON
9	851391	1	SWITCH,TOGGLE,SPST,2-POS
10	1015381	1	CONNECTOR, 31 PIN, HD34-24-31ST
11	981916-02	1	CONN,LOCK WASHER,24 SHELL
12	981916-01	1	CONN,NUT,24 SHELL
13	1017794	1	DECAL, SCREED CONTROL, RH, 815HD

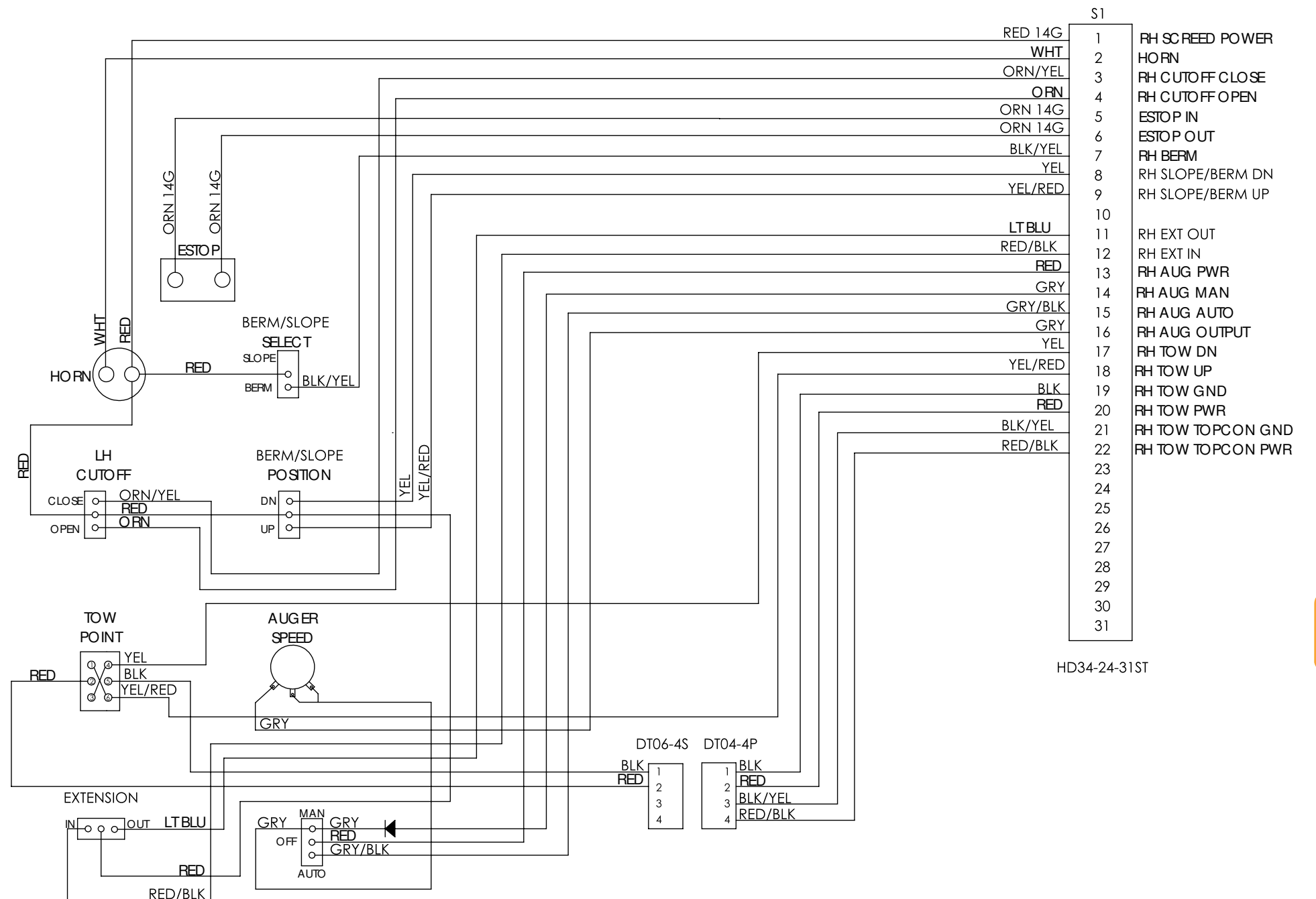
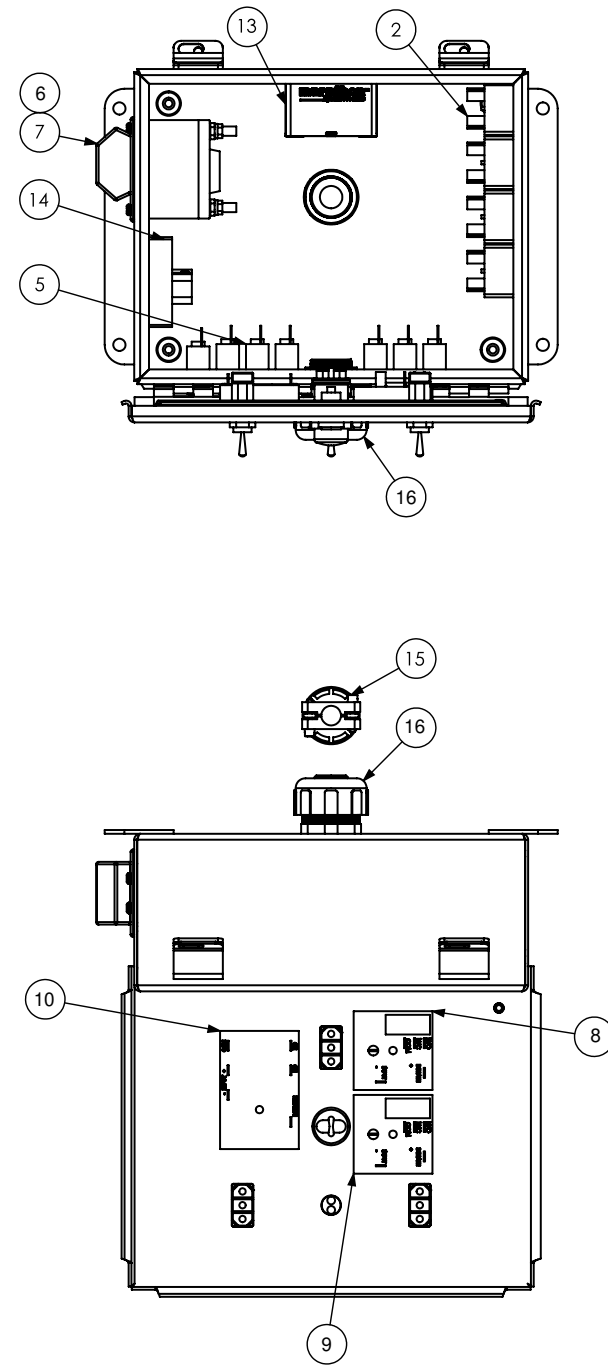
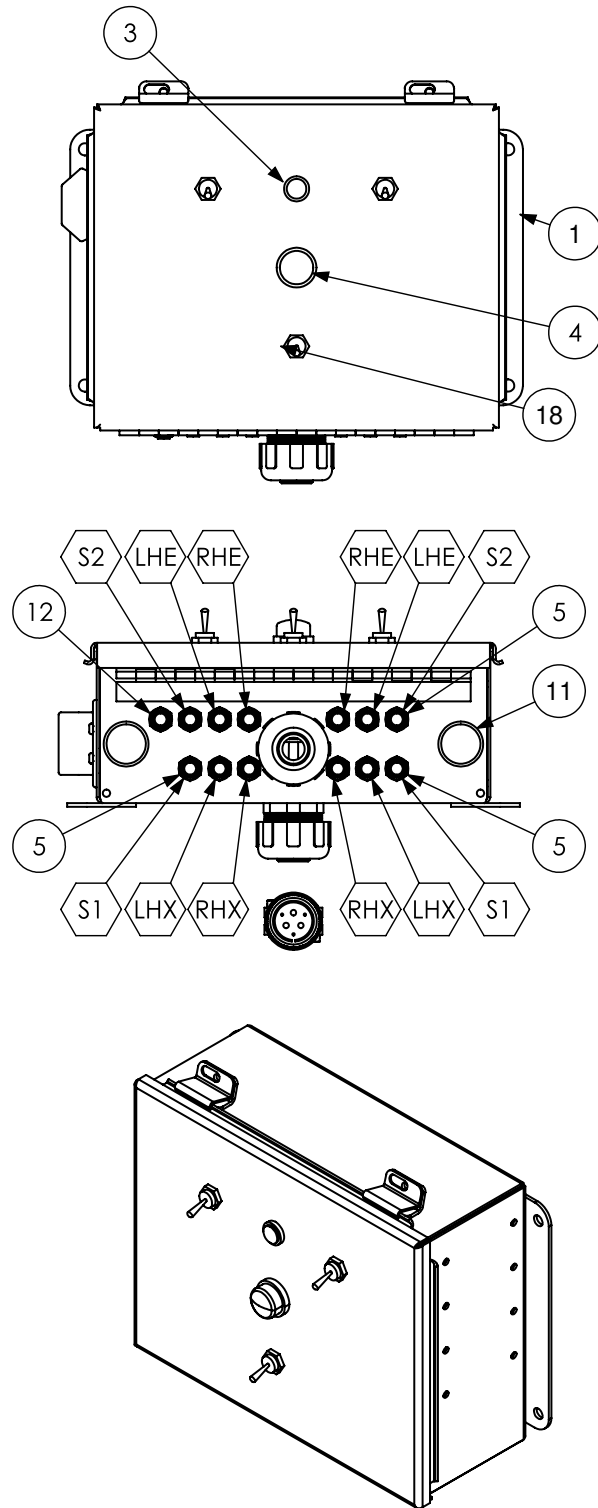

Figure 6-28. Screed Control Box Assembly, 9 Function - Right

NOTES

SCREED HEAT CONTROL BOX ASSEMBLY (1 OF 2)

Schematic for Part # 1016891



ITEM NO.	PART NUMBER	QTY	DESCRIPTION	
1	1016890-01	1	ENCLOSURE, GENERATOR CONTROL BOX, WITH HOLES	
2	985141	4	RELAY 12VDC, DPST, 25AMP, N/O	
3	31983	1	LIGHT, RED, DASH, .50 HOLE	
4	982249	1	SWITCH, PUSH BUTTON	
5	1009228	12	CIRCUIT BREAKER, 10 AMP	
6	1016901	1	CIRCUIT BREAKER, 40AMP, GENERATOR PROTECTION	
7	1016892	1	BOOT, CIRCUIT BREAKER	
8	985142	1	TIMER, ELECTRIC, .06-60 MIN	
9	988230	1	RELAY, TIME DELAY, ON, 10 AMP	
10	988231	1	OFF DELAY TIMER 5 SECONDS	
11	35136-7	2	PLUG, HOLE, .875, FLUSH MT, PLSTC	
12	985140	1	BREAKER, 15AMP	
13	985138-04	1	BLOCK, TERMINAL WITH COVER	
14	1017190	1	AC DETECTOR, HYDRAFORCE, GENERATOR CONTROLLER	
15	985687	1	CONN, 06-PIN, MALE, AMPHENOL	
16	1017228	2	WATER TIGHT, FOR SOLID PVC FLEX CONDUIT .750 MPT	
17	1017229	5	CONDUIT, FLEX PVC .750	
18	851391	3	SWITCH, TOGGLE, SPST, 2-POS	NOT SHOWN

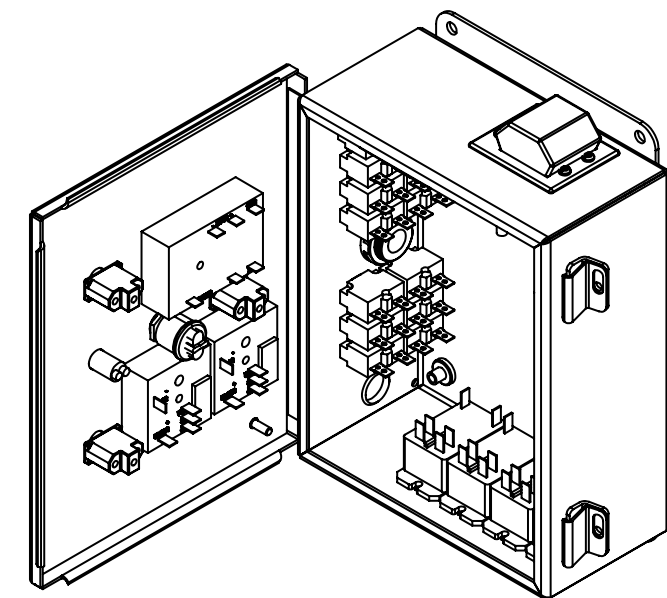

Figure 6-29. Screed Heat Control Box Assembly (1 of 2)

NOTES

SCREED HEAT CONTROL BOX ASSEMBLY (2 OF 2)

Schematic for Part # 1016891

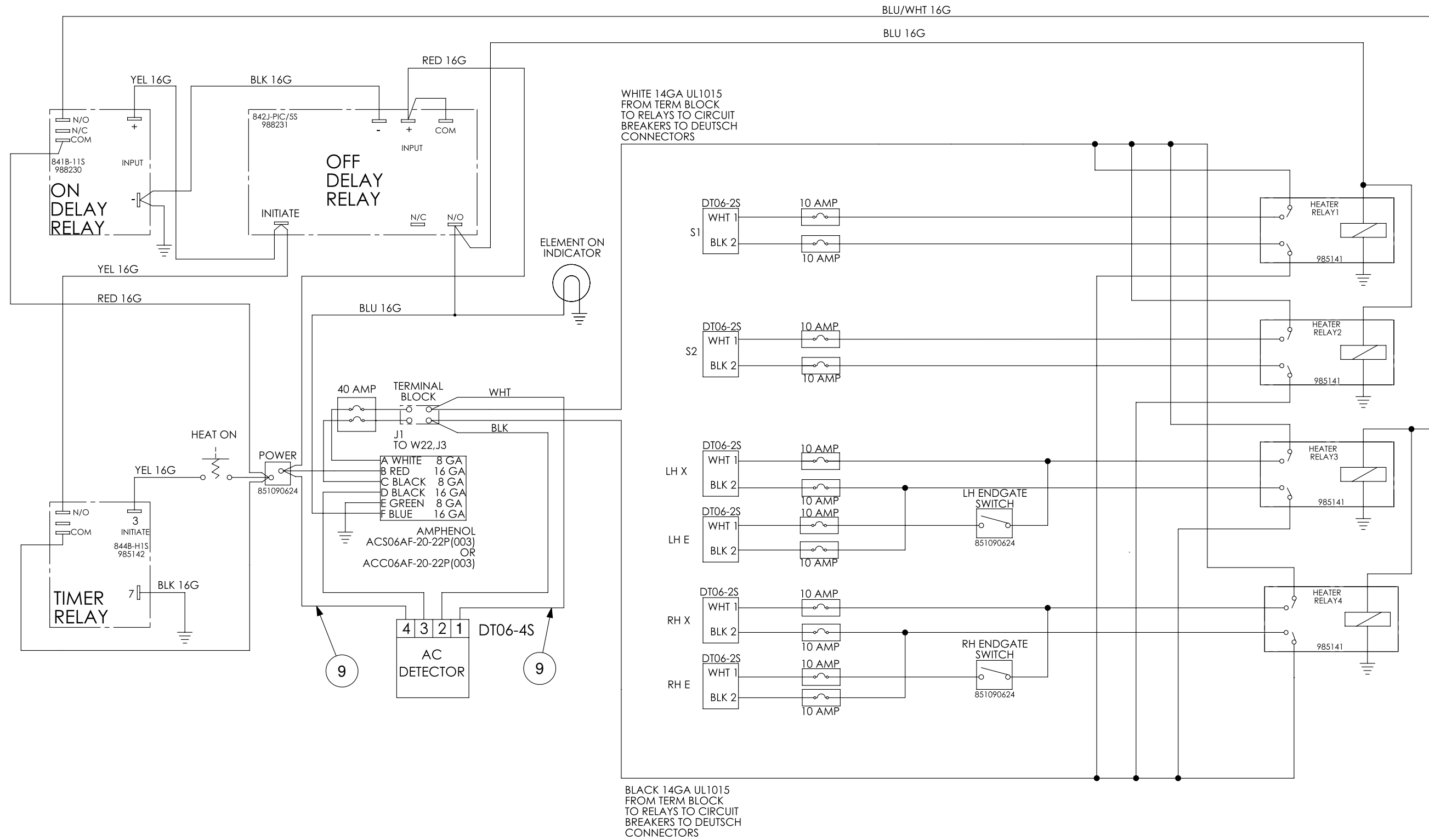

Figure 6-30. Screed Heat Control Box Assembly (2 of 2)

NOTES

SCREED AUTOMATIC TEMPERATURE CONTROL

Schematic for Part # 1017744

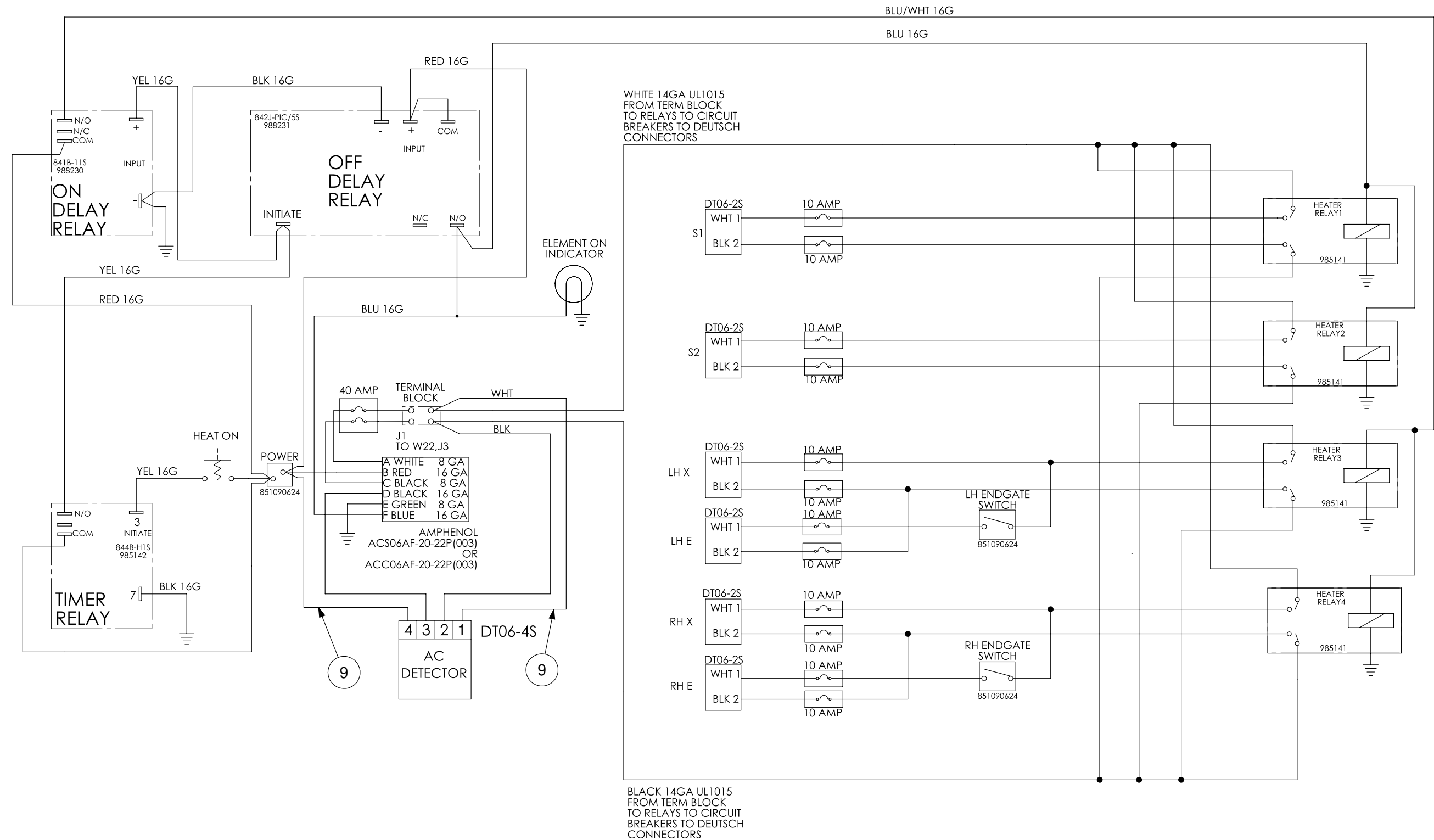

Figure 6-31. Screed Automatic Temperature Control

NOTES

LOWER MANIFOLD HARNESS

Schematic for Part # 1016536

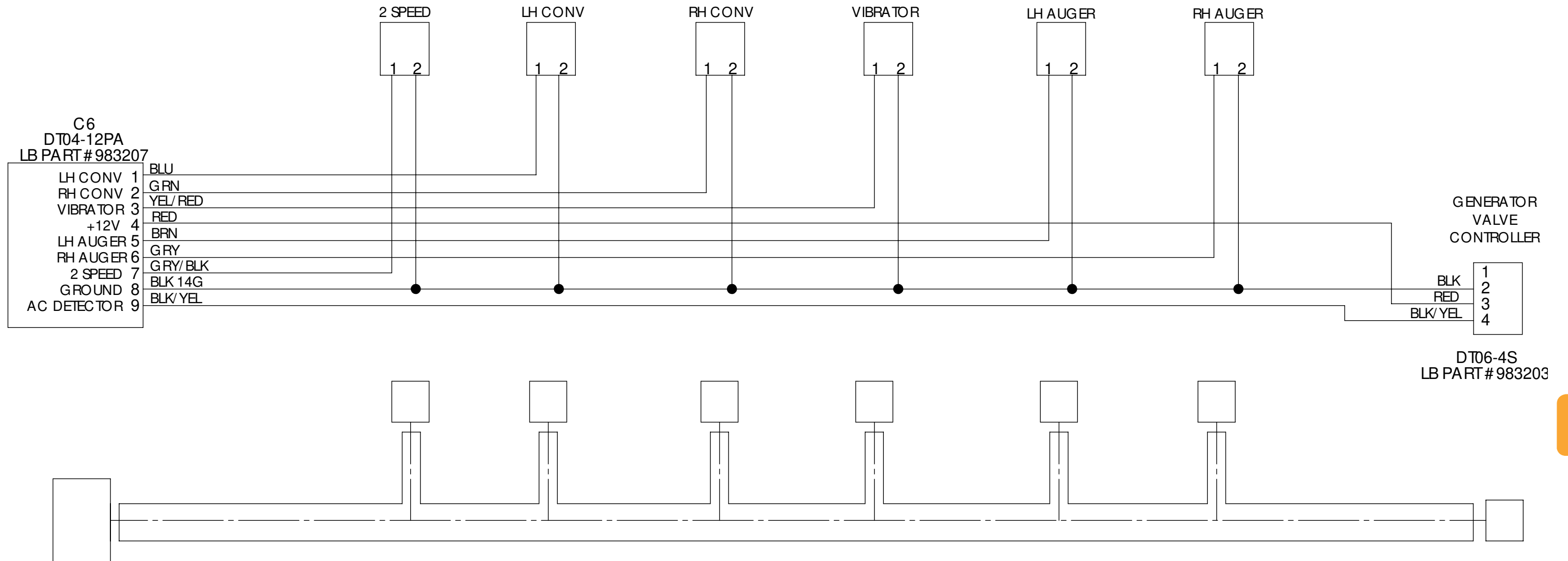

Figure 6-32. Lower Manifold Harness

NOTES

HYDRAULIC COOLER HARNESS

Schematic for Part # 1016702

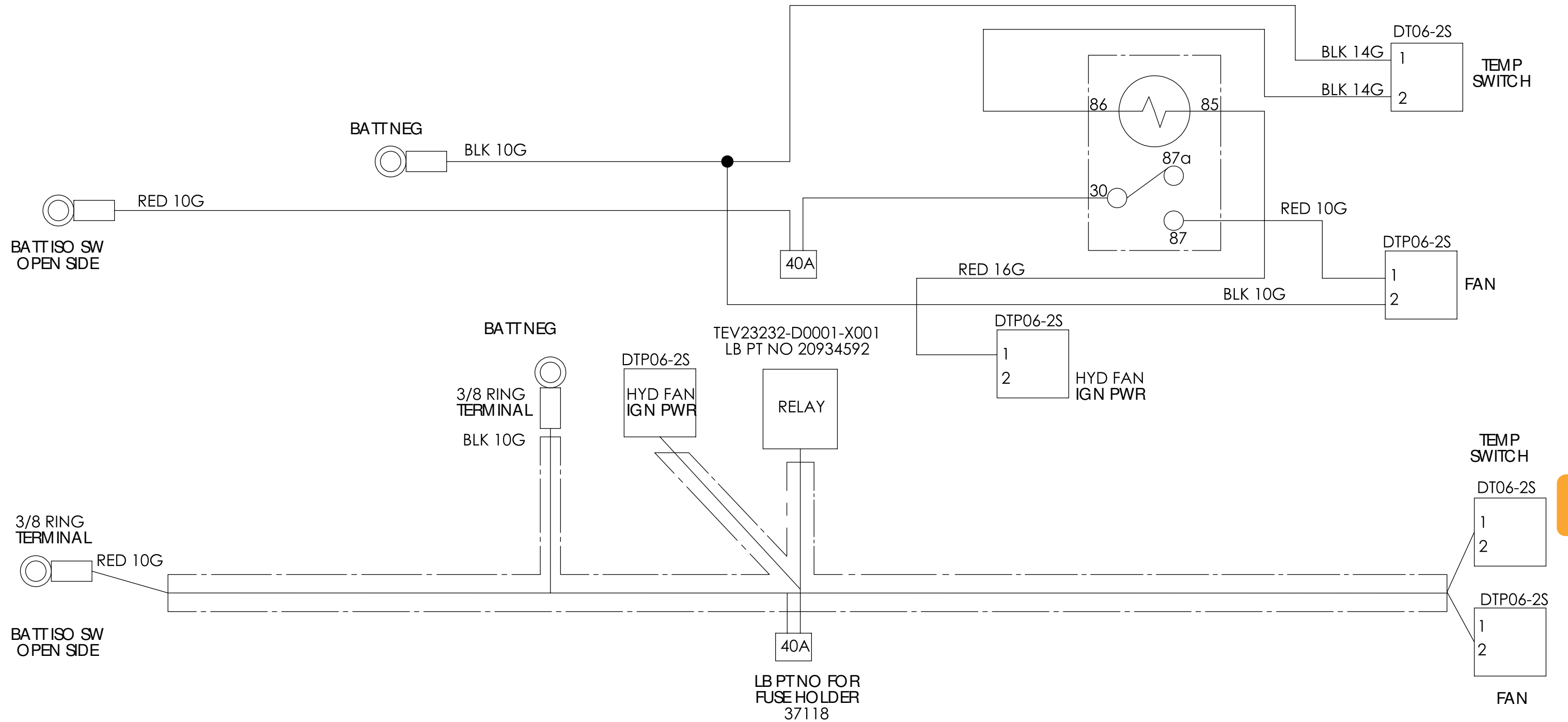

Figure 6-33. Hydraulic Cooler Harness

NOTES

NOTES

GENERATOR VALVE ADAPTER HARNESS

Schematic for Part # 1017192

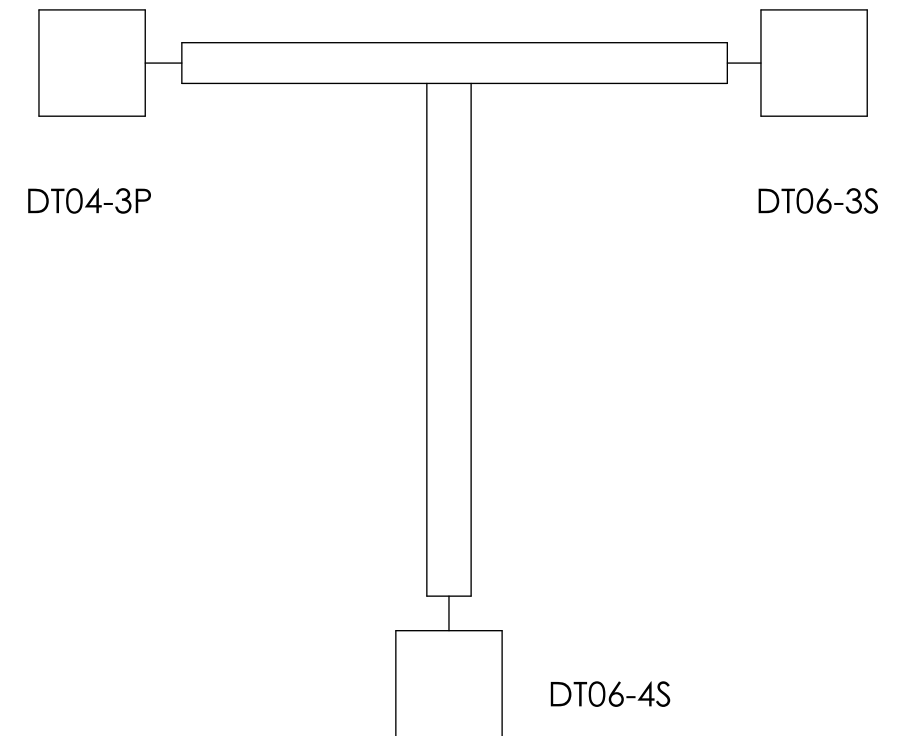
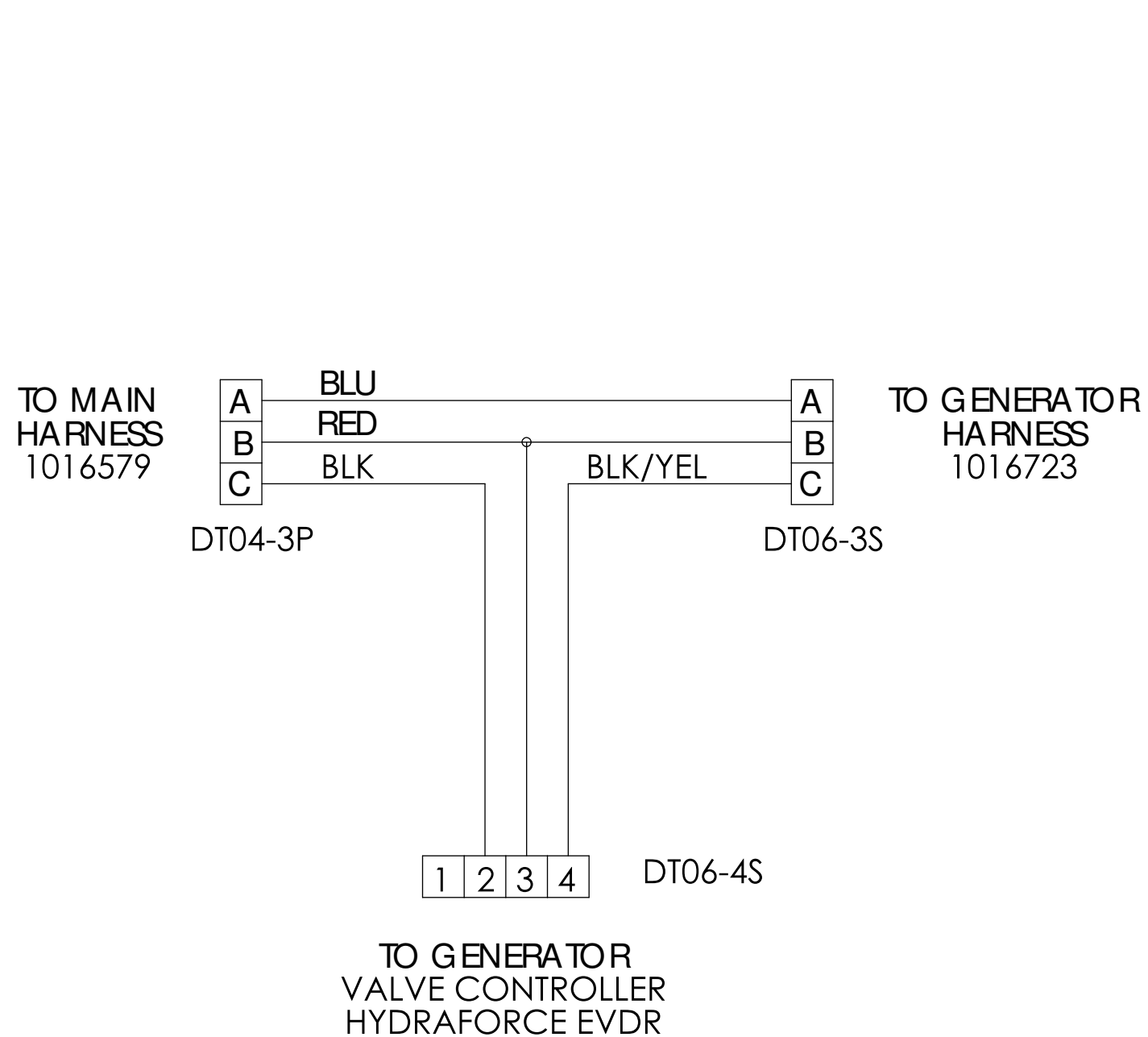

BILL OF MATERIALS			
ITEM	LB PART NUMBER	QTY	DESCRIPTION
	35150-5	3 FT	WIRE, BLACK, 18AWG TXL
	35150-1	4 FT	WIRE, RED, 18AWG, TXL
	35150-16	3 FT	WIRE, BLACK/YELLOW, 18 AWG, TXL
	35150-3	0.5 FT	WIRE, BLUE, 18AWG, TXL
	983200	1	CONN,3-PIN SOCKET,DT04-3P
	983211	1	CONNECTOR, WEDGELOCK, DEUTSCH, W3P
	983201	1	CONN,03-PIN,PLUG,DT06-3S DEUTSCH
	983210	1	CONNECTOR, 03-PIN, WEDGE, PLUG, DEUTSCH
	983203	1	CONN,04-PIN,PLUG,DT06-4S DEUTSCH
	983212	1	CONN,WEDGE,PLUG,4S,DEUTSCH
	982448	6	TERMINAL,SOCKET,DEUTSCH,14-16
	982456	3	PIN, DEUTSCH, 14-16AWG
	73192-02	1	SEAL PLUG, DEUTSCH, WHITE, SIZE 16-12

Figure 6-35. Generator Valve Adapter Harness

NOTES

LOAD CONTROL BOX TO BULKHEAD HARNESS

Schematic for Part # 1016723

ACC00AF20-22S003

ACC00AF20-22S003

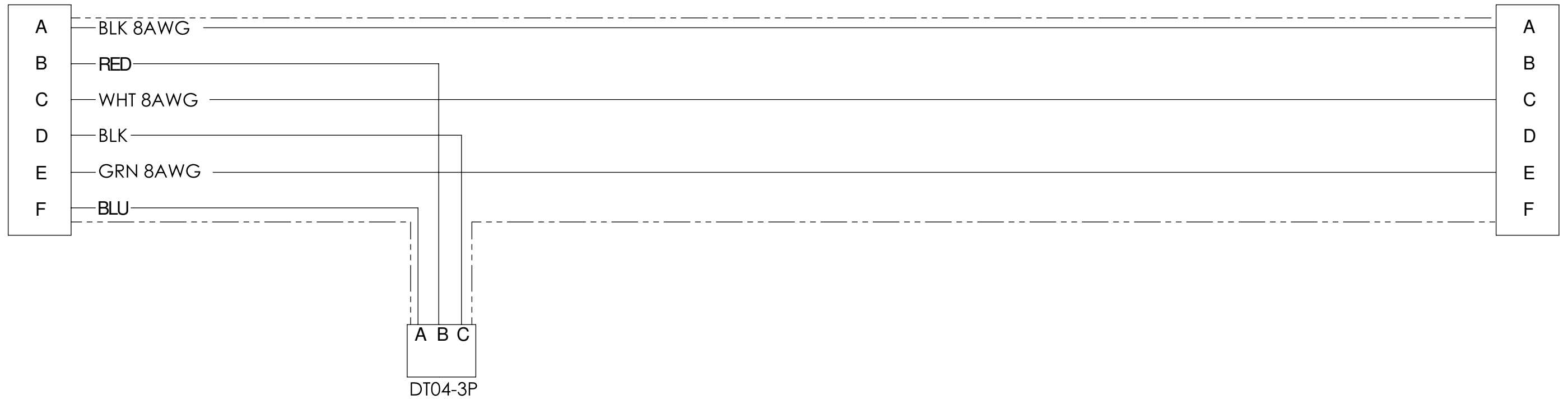

Figure 6-36. Load Control Box to Bulkhead Harness

NOTES

BULKHEAD TO GENERATOR HARNESS

Schematic for Part # 1016724

AMPHENOL
ACC 06 E20-22P

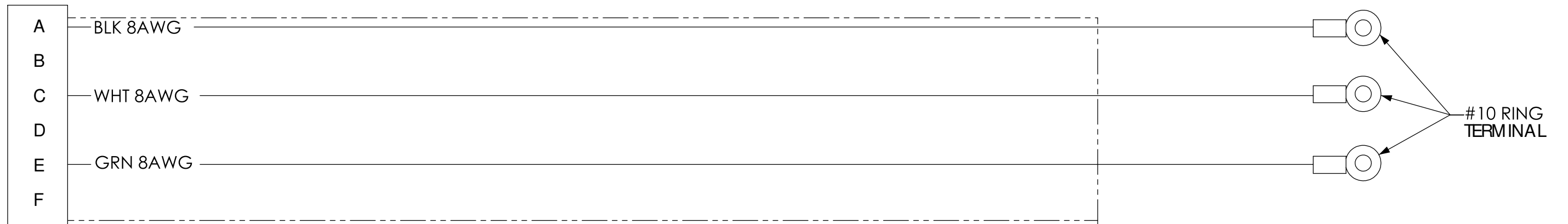

Figure 6-37. Bulkhead to Generator Harness

NOTES

JOYSTICK CONTROL BOX

Schematic for Part # 1016272SRV

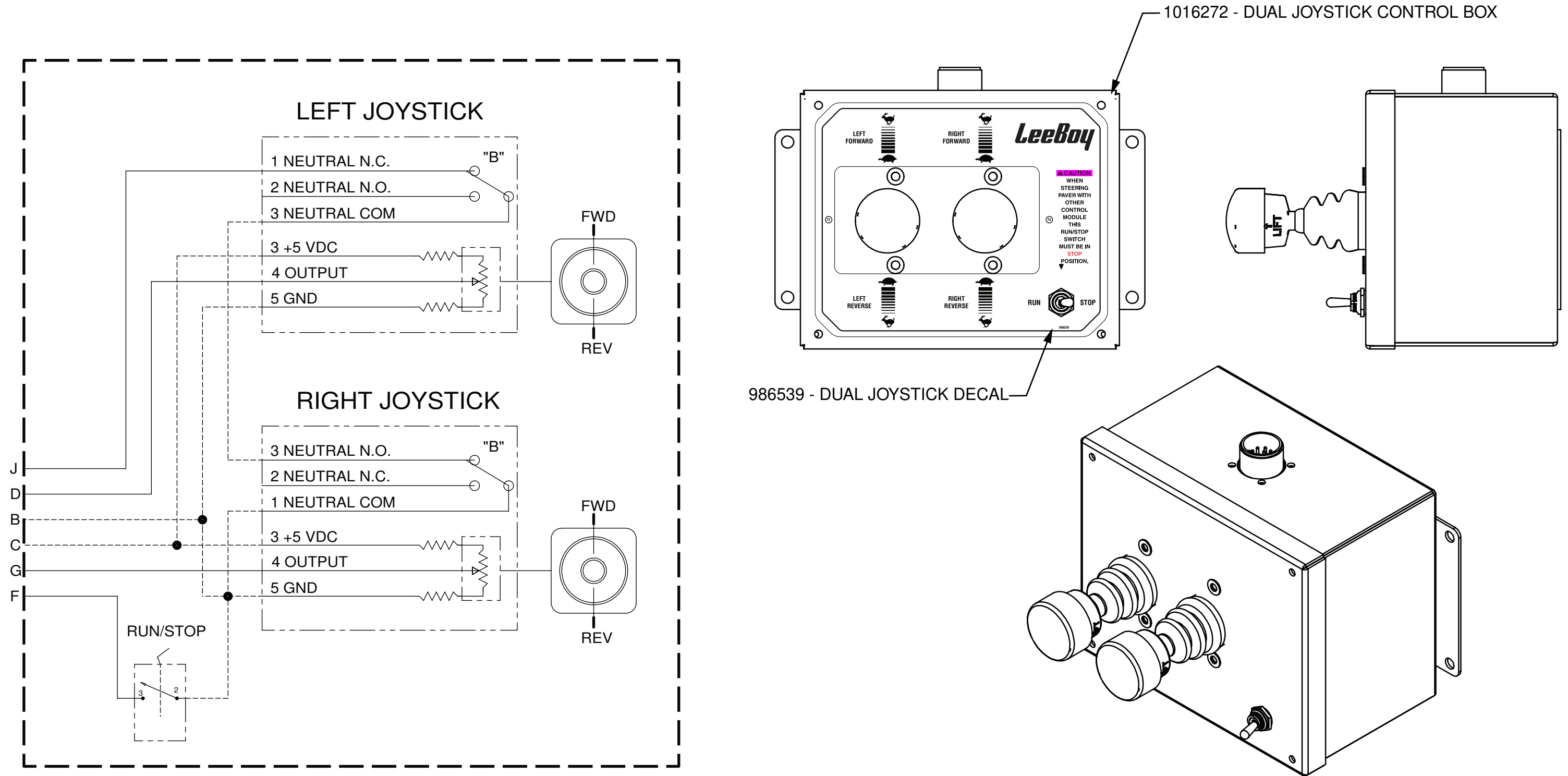

Figure 6-38. Joystick Control Box

NOTES

STEERING WHEEL CONTROL BOX

Schematic for Part # 1000708

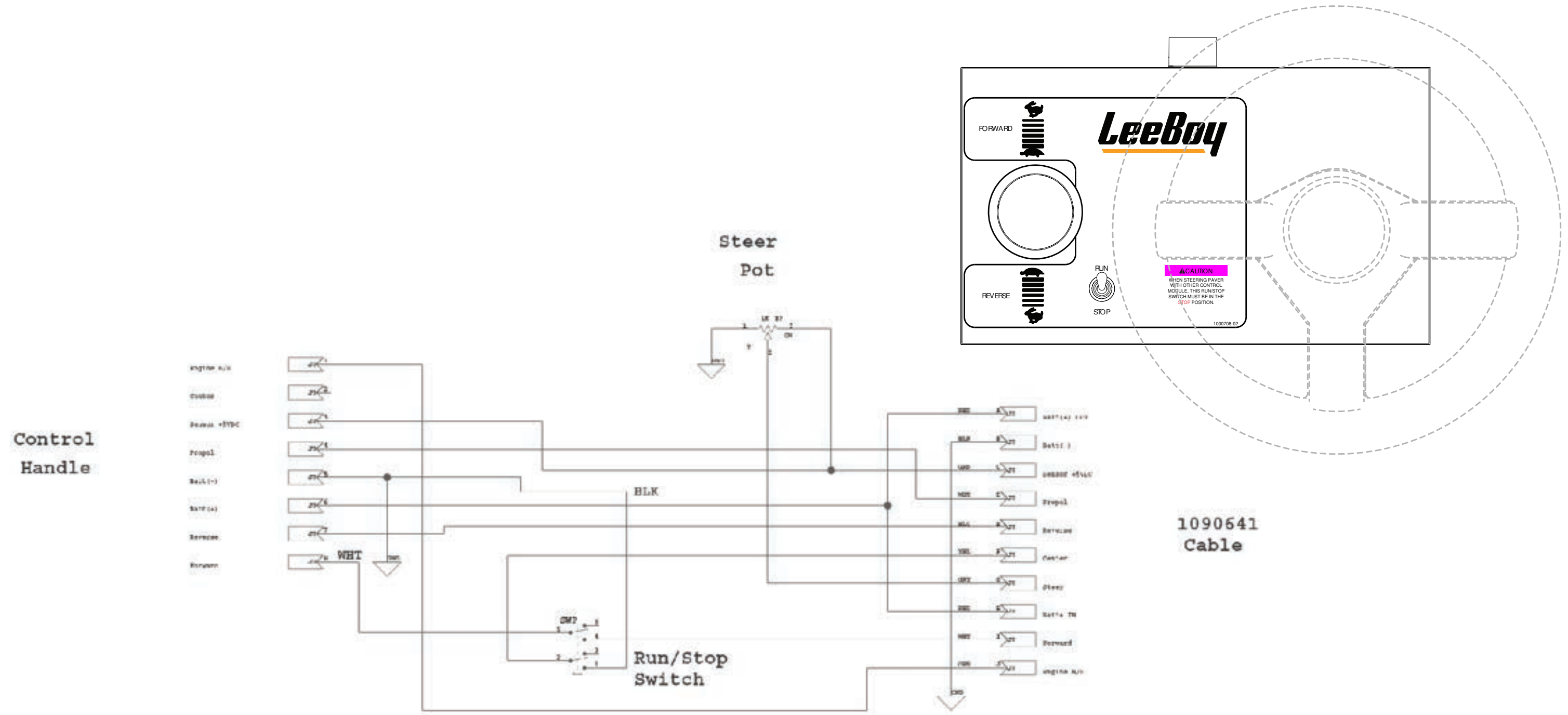

Figure 6-39. Steering Wheel Control Box

NOTES

ELECTRONIC STEERING CORD

Schematic for Part # 851548-04

ITEM NO.	PART NUMBER	QTY	DESCRIPTION
1	CS3106A-18-1S-472	2	AMPHENOL CONNECTOR

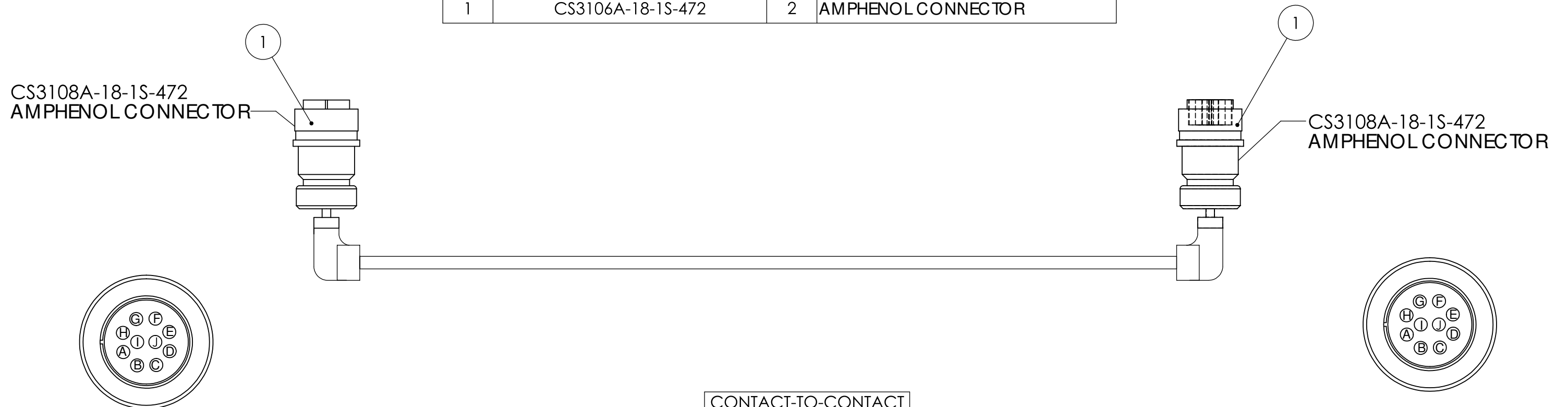

CONTACT-TO-CONTACT	
A	A
B	B
C	C
D	D
E	E
F	F
G	G
H	H
I	I
J	J

Figure 6-40. Electronic Steering Cord

NOTES

SCREED BERM WIRING SCHEMATIC

Schematic for Part #

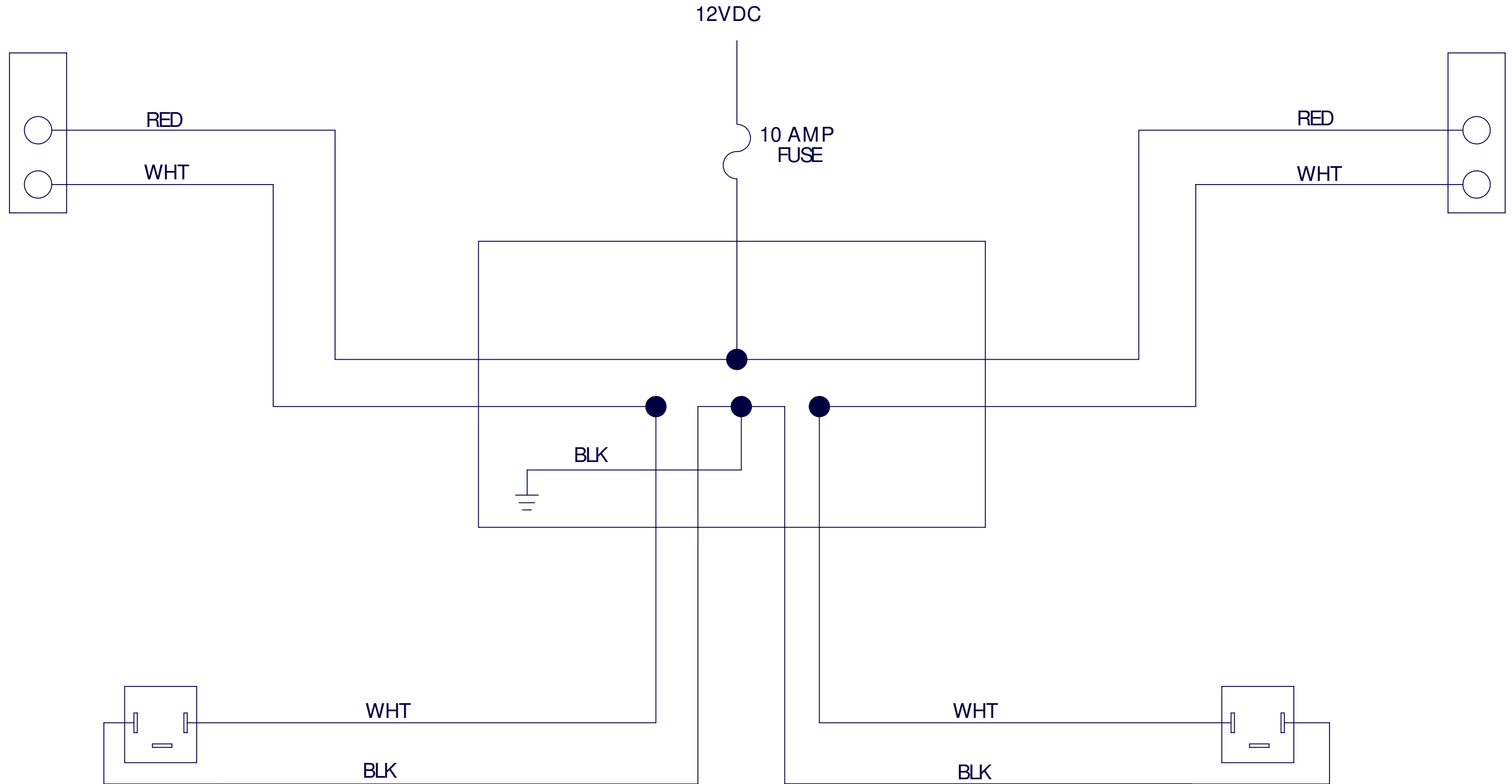

Figure 6-41. Screed Berm Wiring Schematic

NOTES

HYDRAULIC SCHEMATIC (1 OF 5)

Schematic for Part # 1016855

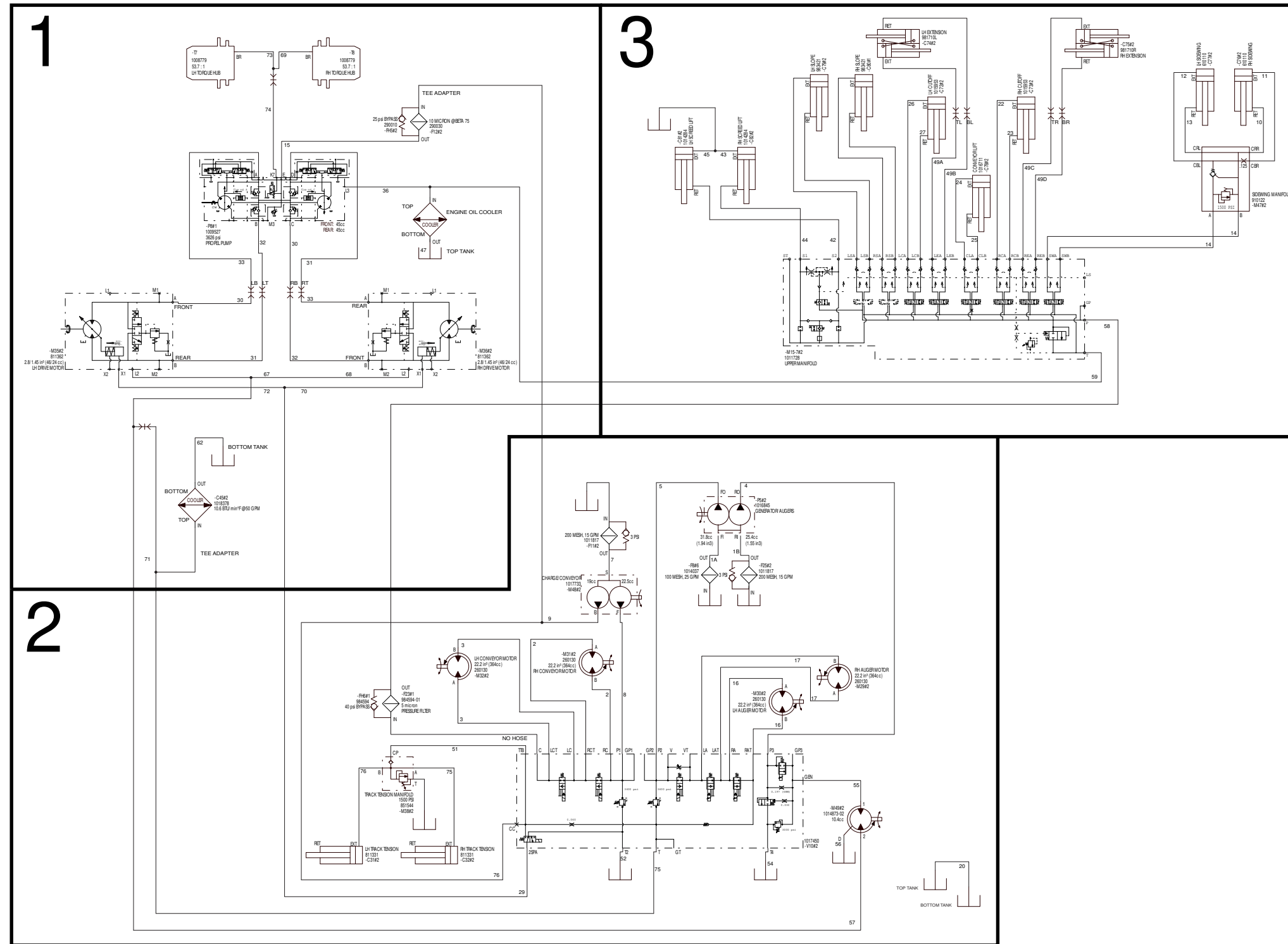

Figure 6-42. Hydraulic Schematic (1 of 5)

NOTES

HYDRAULIC SCHEMATIC (2 OF 5)

Schematic for Part # 1016855

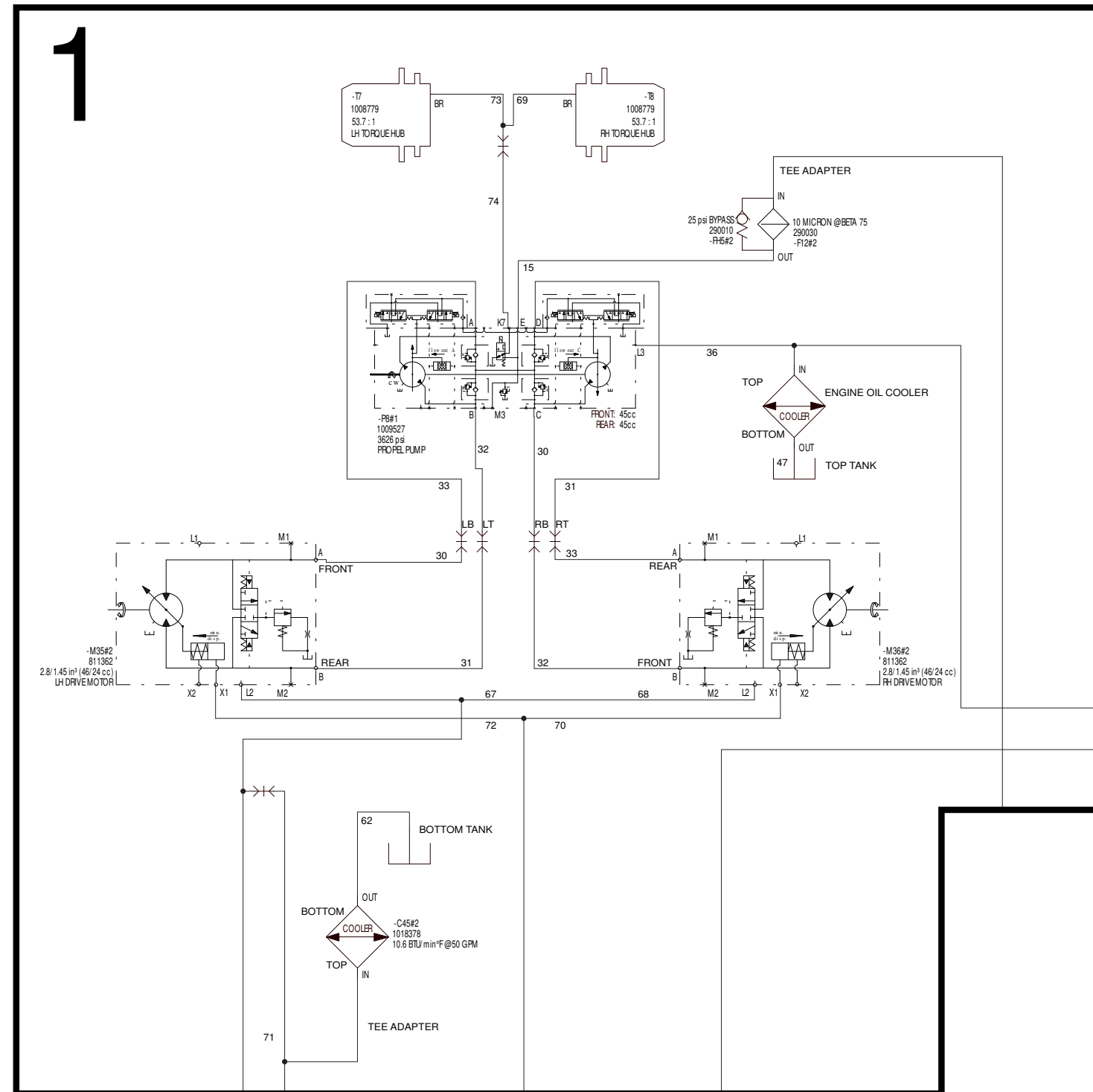

Figure 6-43. Hydraulic Schematic (2 of 5)

NOTES

HYDRAULIC SCHEMATIC (3 OF 5)

Schematic for Part # 1016855

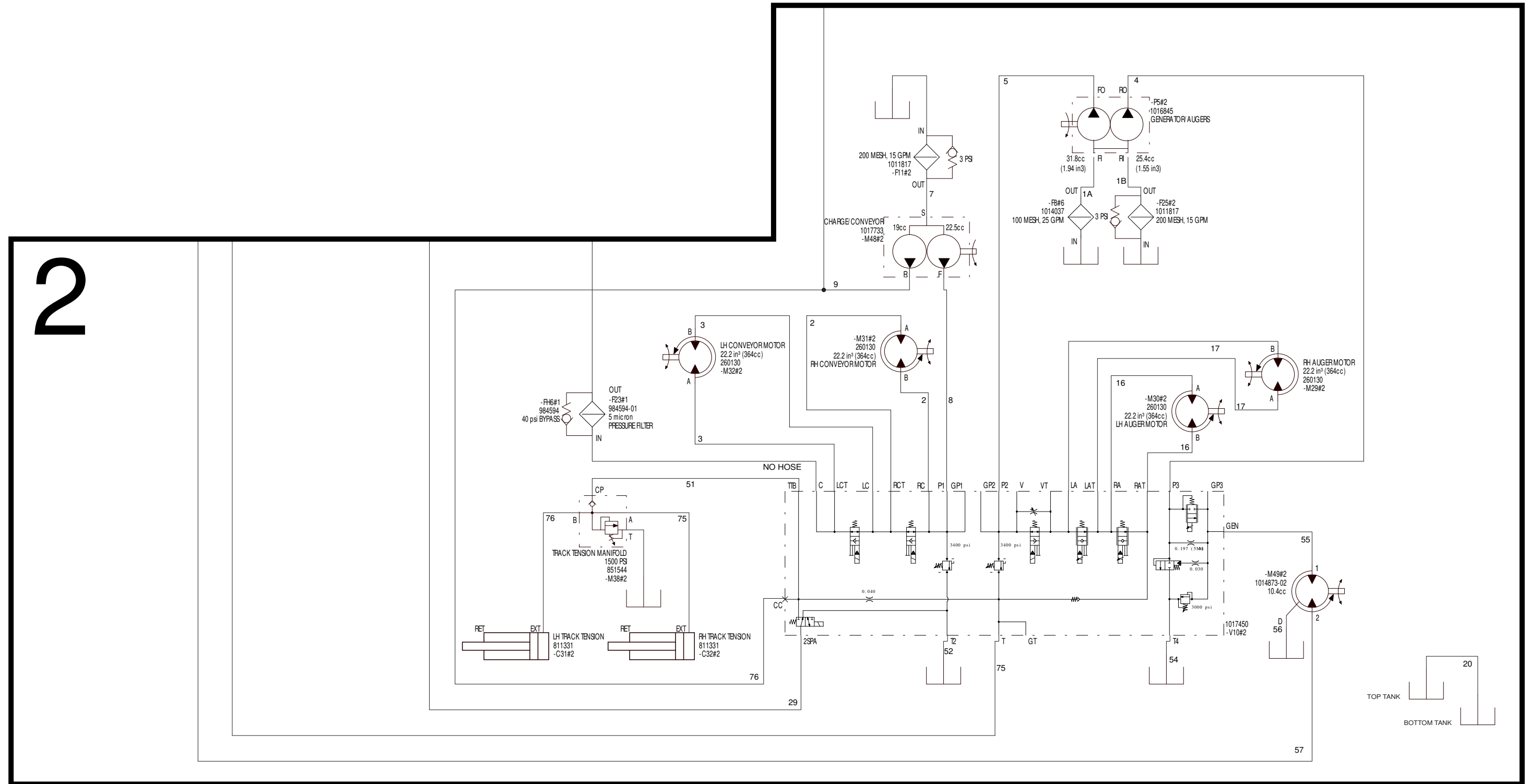

Figure 6-44. Hydraulic Schematic (3 of 5)

NOTES

HYDRAULIC SCHEMATIC (4 OF 5)

Schematic for Part # 1016855

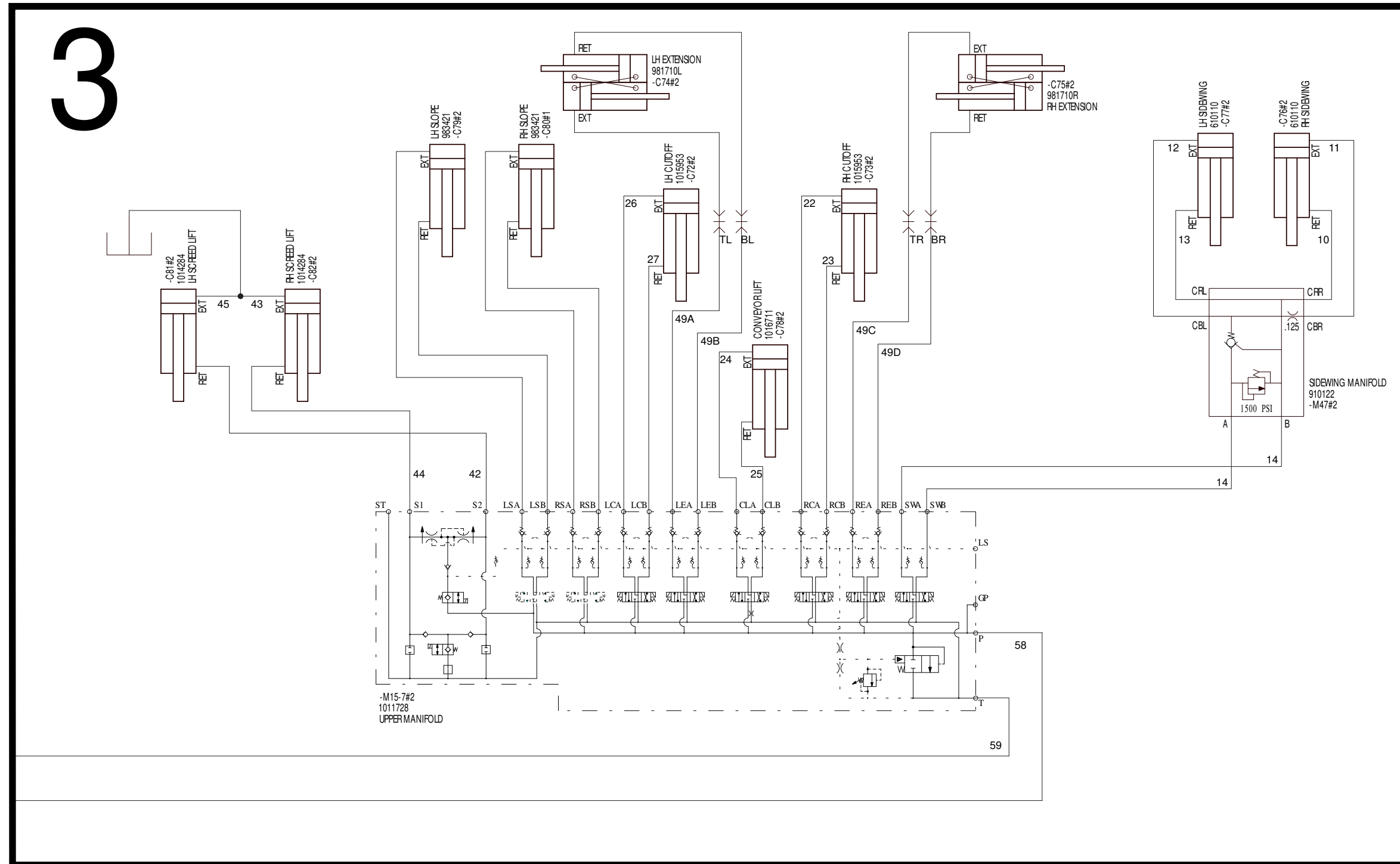
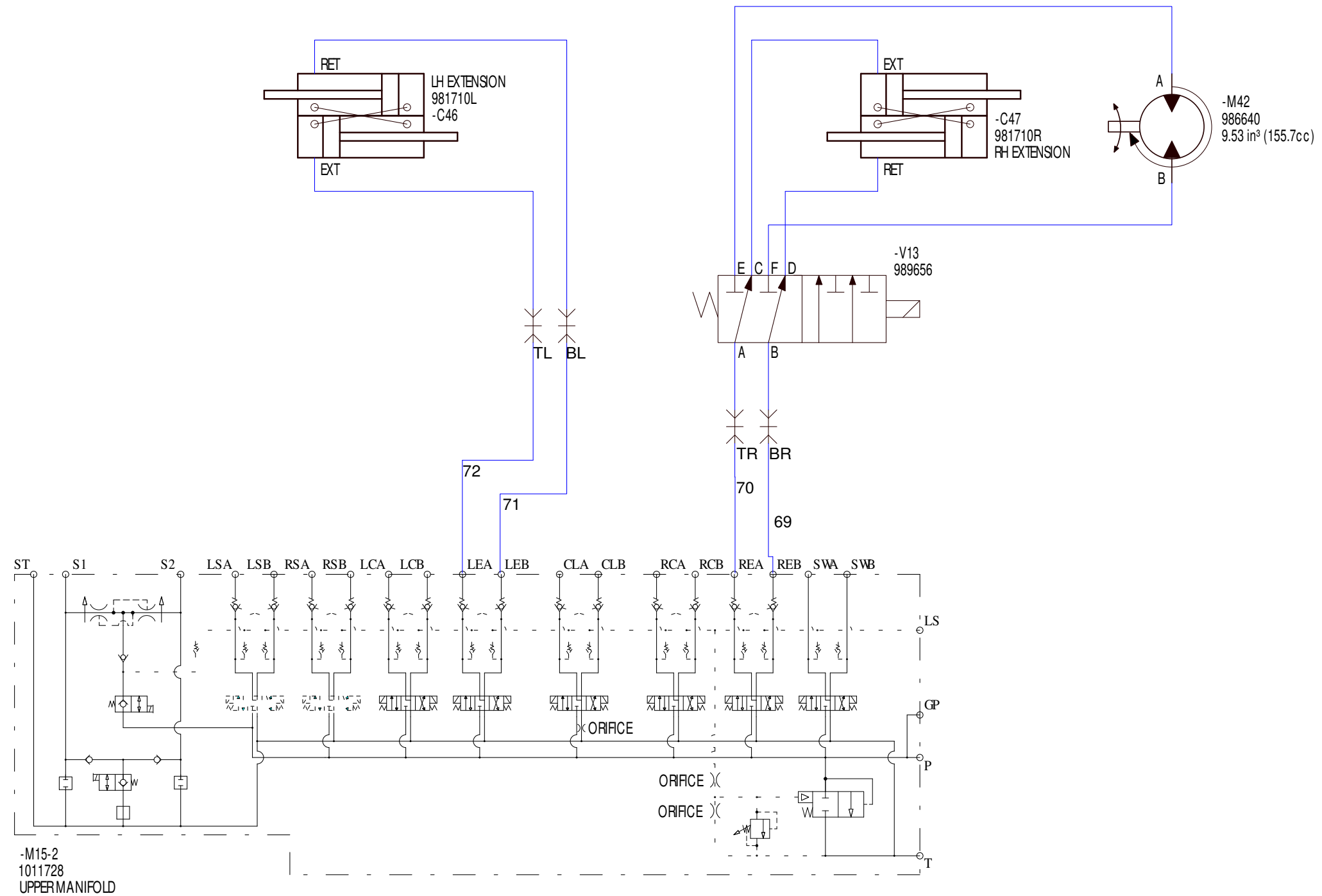

Figure 6-45. Hydraulic Schematic (4 of 5)

NOTES

HYDRAULIC SCHEMATIC (5 OF 5)

Schematic for Part # 1016855



OPTIONAL: POWER CROWN

Figure 6-46. Hydraulic Schematic (5 of 6)

NOTES

Section 7

ILLUSTRATED PARTS LIST

	Page
Illustrated Parts List	7-1
Quick Reference	7-5
Track Assembly - Poly Pads/Cast Steel (1 of 2)	7-6
Track Assembly - Poly Pads/Cast Steel (2 of 2)	7-8
Track Assembly - Continuous Rubber (1 of 2)	7-10
Track Assembly - Continuous Rubber (2 of 2)	7-12
Push bar Assembly	7-14
Conveyor Assembly (1 of 2)	7-16
Conveyor Assembly (2 of 2)	7-18
Conveyor Drive & Paddle Assembly (1 of 2)	7-20
Conveyor Drive & Paddle Assembly (2 of 2)	7-22
Hopper Wings	7-24
Rear Auger Assembly (1 of 2)	7-26
Rear Auger Assembly (2 of 2)	7-28
Fuel Tank Assembly	7-30
Hydraulic Tank Assembly	7-32
Hydraulic Test Ports	7-34
Engine Assembly - Radiator	7-36
Engine Assembly - Intake/Exhaust	7-38
Engine Assembly - Components (1 of 2)	7-40
Engine Assembly - Components (2 of 2)	7-42
Engine Assembly - Pumps	7-44
Hoods and Covers - Left	7-46
Hoods and Covers - Right	7-48
Spray Down	7-50
Tow Point Assembly	7-52



Illustrated Parts List



Hydraulic Manifold - Upper	7-54
Hydraulic Manifold - Lower	7-56
Hydraulic Oil Cooler	7-58
Generator	7-60
Hydraulic Cylinders	7-62
Dash Assembly - Controls	7-64
Dash Assembly - Mounting	7-66
Control Box Assembly-4 Function Screed Ctrl (1 of 2)	7-68
Control Box Assembly-4 Function Screed Ctrl (2 of 2)	7-70
Control Box Assembly-9 Function Screed Ctrl (1 of 2)	7-72
Control Box Assembly-9 Function Screed Ctrl (2 of 2)	7-74
Seat Assembly & Details	7-76
HD Screed Overview - Sloping and Non-Sloping	7-78
HD Screed Frame Assembly (1 of 2)	7-80
HD Screed Frame Assembly (2 of 2)	7-82
HD Screed Extension Assembly - Left	7-84
HD Screed Extension Assembly - Right.	7-86
HD Screed Slide Plate Assembly	7-88
HD Screed Pull Arm Assembly, 4 Function - Left	7-90
HD Screed Pull Arm Assembly, 4 Function - Right.	7-92
HD Screed Pull Arm Assembly, 9 Function - Left	7-94
HD Screed Pull Arm Assembly, 9 Function - Right.	7-96
HD Screed Thickness Adjuster - Standard	7-98
HD Screed Endgates.	7-100
HD Screed Vibrators and Walkboards	7-102
HD Screed Citrus Tank.	7-104
HD Screed Control Assembly	7-106
Option - HD Berm Screed Overview	7-108
Option - HD Berm Screed Ext. Assembly - Left (1 of 2).	7-110
Option - HD Berm Screed Ext. Assembly - Left (2 of 2)	7-112
Option - HD Berm Screed Ext. Assembly - Right (1 of 2)	7-114
Option - HD Berm Screed Ext. Assembly - Right (2 of 2).	7-116
Option - HD Berm Screed Remote Assembly	7-118
Option - HD 3:1 Depth Screws (1 of 2).	7-120
Option - HD 3:1 Depth Screws (2 of 2).	7-122
Option - HD Screed Heated Endgates	7-124



Option - HD Screed Heated Safety Edge Endgates7-126
Option - HD Miscellaneous Options7-128
Option - Legend Non-Sloping Screed Overview7-130
Option - Legend Sloping Screed Overview7-132
Option - Legend Non-Sloping Screed Frame Assembly.7-134
Option - Legend Sloping Screed Frame Assembly7-136
Option - Legend Screed Extension Single Adjust - Left7-138
Option - Legend Screed Extension Single Adjust - Right7-140
Option - Legend Screed Extension 4-Way Adjust - Left7-142
Option - Legend Screed Extension 4-Way Adjust - Right7-144
Option - Legend Screed Slide Plates7-146
Option - Legend Screed Pull Arm Assembly - Left.7-148
Option - Legend Screed Pull Arm Assembly - Right7-150
Option - Legend Screed Endgate - Left.7-152
Option - Legend Screed Endgate - Right7-154
Option - Legend Screed Citrus Tank7-156
Option - Legend Screed Power Crown7-158
Option - Screed Automatic Temperature Controller.7-160
Option - Dual Steering Wheels7-162
Option - 12" Auger Extension7-164
Option - 24" Auger Extension.7-166
Option - Curb Attachments7-168
Option - 20' Paver Leveling Ski Assembly.7-170
Option - 30'-40' Paver Leveling Ski Assembly7-172
Option - TopCon P-32 Control Assembly7-174
Option - Truck Hitch Assembly7-176
Option - Umbrella & Fire Extinguishers7-178
Hydraulic Hose Schedule - Standard Unit.7-180
Hydraulic Hose Schedule - Options7-182
Decal Schedule7-184
Alphabetical Parts Index7-186



Illustrated Parts List



QUICK REFERENCE



FILTERS/STRAINERS		
Engine	Description	Part #
	Oil Filter	986537-03
	Water Separator	1009253-19
	Fuel Filter	1009253-18
	Air Cleaner, Primary	1009253-17
	Air Cleaner, Secondary	38385-02
Hydraulic		
	Suction Strainer, 1-7/8-12 SAE	1011817
	Suction Strainer, 2-1/2-12 SAE	1014037
	Charge Filter	290030
	Charge/Return Filter Head	290010
Spray Down		
	Pump and Strainer Kit	1015532
	Filter	986537-31

ENGINE COMPONENTS		
	Description	Part #
	Engine Belt	1009253-20
	Alternator	1009253-21
	Starter	1001166-03

ELECTRICAL COMPONENTS		
	Description	Part #
	FUSE KIT:	
	• 5A ATC (1)	36746
	• 10A ATC (11)	36340
	• 15A ATC (2)	36341
	• 20A ATC (3)	36342
• 25A ATC (1)	37303	
	Fuse Block, ATC	685060
	Breaker, 10A	986546

TRACK ASSEMBLIES		
	Description	Part #
	Track Assembly w/Poly Pads	851101P
	Track Assembly w/Cast Steel Pads	851101
	Continuous Rubber Track	982585

WEAR PLATES		
	Description	Part #
	HD Main Screed, 3/8" w/ Studs	1016475
	HD Ext. Heat Box Assy (LH/RH)	1006380SRV
	HD Ext. Wear Plate (LH/RH)	1006382
	Berm Ext. Main Heat Box Assy (LH)	1017683SRV
	Berm Ext. Main Heat Box Assy (RH)	1017682SRV
	Legend Main Screed	987216SRV
	Legend Ext. 1-Adj HB Assy (LH/RH)	987872SRV
	Legend Ext. 4-Adj HB Assy (LH/RH)	988319SRV
	Legend Ext. Wear Plate (LH/RH)	854456

HEATING ELEMENTS		
	Description	Part #
	HD Main Heating Element (2)	1015016SRV
	HD Ext Heating Element (2)	987890SRV
	Berm Main Ext. HE (2)	1015936
	Berm Ext. Heating Element (2)	1015918
	Legend Main Heating Element (2)	987886SRV
	Legend Ext Heating Element (2)	987890SRV

Specifications and designs may change without prior notice. These illustrations do not necessarily show the standard versions.

Illustrated Parts List

TRACK ASSEMBLY - POLY PADS/CAST STEEL (1 OF 2)

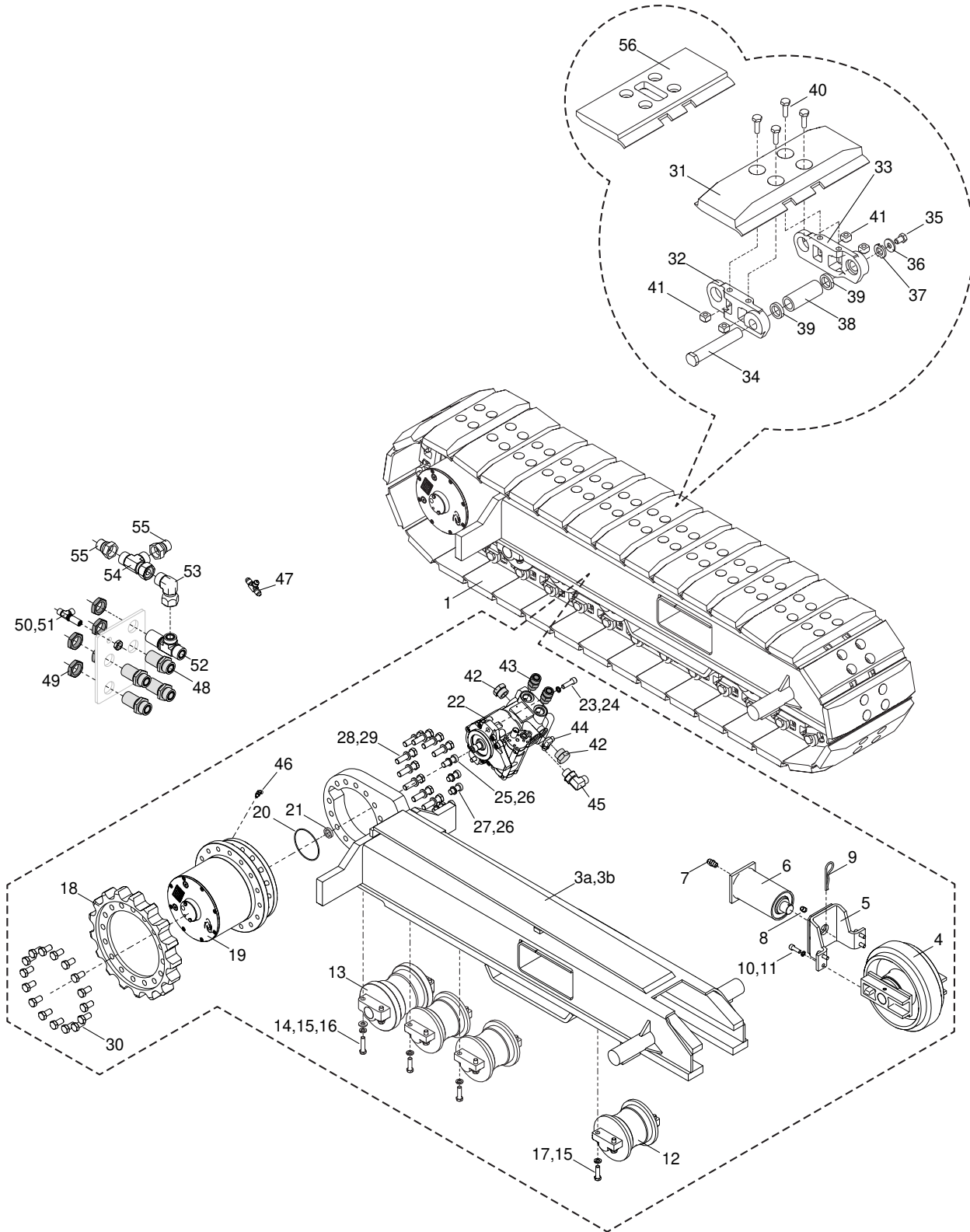

Figure 7-1. Track Assembly - Poly Pads/Cast Steel (1 of 2)

Track Assembly - Poly Pads/Cast Steel (1 of 2)

Item No	Part Number	Qty	Description	Remarks
GRP	1017203		Group - PolyPad Drive	
REF	1009742	1	Polypad Track/Undercarriage Assembly - Right	Includes Item 2a
REF	1009741	1	Polypad Track/Undercarriage Assembly - Left	Not Shown; Includes Item 2b
1	851101P	2	Track Assembly w/Polypads	Includes Items 29 - 39
3a	1008789	1	Undercarriage Weldment - Right	
3b	1008788	1	Undercarriage Weldment - Left	Not Shown
4	1001589	2	Track Idler	
5	811329ASRV	2	Front Track Idler Yoke, Short	
6	811331	2	Hydraulic Cylinder, Track Tensioner	
REF	811331-01	A/R	Seal Kit, Track Tensioner Cylinder	
7	FS2404-10-08	2	Connector Adapter, -10 ORFS/-8 NPTF	
8	851644	2	Track Tensioner Cylinder Breather	Included with Item 6
9	870307	2	Cotter Pin, .177, 7 GA	
10	102-M10-1.5-30-10.9F	8	CSSH, M10x1.5 x 30, C10.9, FT	
11	307-M10	8	Washer, Lock, Hi-Collar, M10	
12	811326	6	Track Roller, B/O	
13	851566	2	Track Roller, B/1, N/S	
14	100-M12-1.75-50-8.8F	8	CSHH, M12x1.75 x 50, C8.8, FT	
15	302-8	A/R	Washer, Lock, 1/2	
16	300-8	8	Washer, Flat, SAE, 1/2	
17	100-M12-1.75-40-8.8F	A/R	CSHH, M12x1.75 x 40, C8.8, FT	
18	1006737	2	Track Sprocket (Comer)	
19	1008779	2	Torque Hub w/Disconnect (Comer)	
20	811366	2	O-Ring, Hydraulic Motor to Torque Hub	
21	59941203	A/R	Seal, Hydraulic Drive Motor	
22	811362	2	Hydraulic Drive Motor, 2-Speed	
REF	851494	1	Pump Servo Cover Gasket	Not Shown
23	102-M12-1.75-40-8.8F	4	CSSH, M12x1.75 x 40, C8.8, FT	
24	307-M12	4	Washer, Lock, Hi-Collar, M12	
25	1008903	2	Low Socket Cap Screw, M16x2 x 45	
26	307-M16	A/R	Washer, Lock, Hi-Collar, M16	
27	1008895	8	Low Socket Cap Screw, M16x2 x 35	
28	100-M16-2-65-8.8F	18	CSHH, M16x2 x 65, C8.8, FT	
29	302-10	A/R	Washer, Lock, 5/8	
30	100-M16-2-30-8.8F	A/R	CSHH, M16x2 x 30, C8.8, FT	
31	851104	A/R	Poly Track Pad, 14"	
32	853195	A/R	Track Chain Link - Right	
33	853194	A/R	Track Chain Link - Left	
REF	811306	A/R	Master Track Link Pin	Includes Items 32-35
34	811307	A/R	Track Link Pin	

Illustrated Parts List

TRACK ASSEMBLY - POLY PADS/CAST STEEL (2 OF 2)

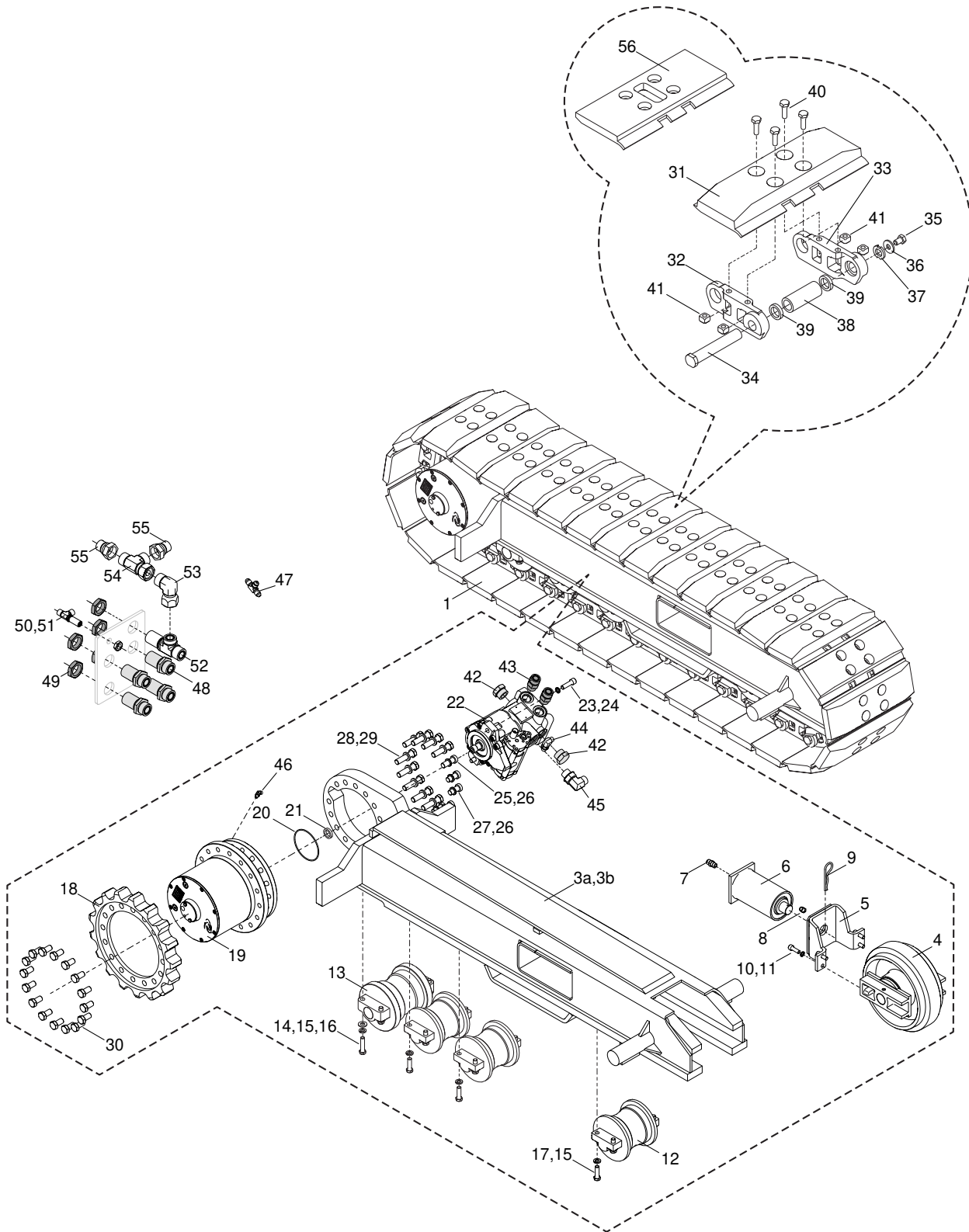

Figure 7-1. Track Assembly - Poly Pads/Cast Steel (2 of 2)

Track Assembly - Poly Pads/Cast Steel (2 of 2)

Item No	Part Number	Qty	Description	Remarks
35	989272-50	A/R	CSHH, M10x1.50 x 16	
36	300-M10	A/R	Washer, Flat, SAE, M10	
37	811305	A/R	Track Chain Master Pin Washer	
38	851460	A/R	Track Link Short Bushing	
39	811310	A/R	Track Link Bushing Spacer	
40	811308	A/R	Track Pad Hex Bolt	
41	811309	A/R	Track Pad Bolt Nut	
42	6408-16-0	4	Plug Adapter, -16 O-Ring	
43	FS6400-12-12-O	4	Straight Adapter, -12 ORFS/-12 ORFS	
44	FS6801-04-06-NWO-FG	2	Elbow Adapter, 90°, -4 ORFS/-6 O-Ring	
45	FS6801-10-12-NWO-FG	2	Elbow Adapter, 90°, -10 ORFS/-12 O-Ring	
46	FS6802-04-04-NWO-FG	2	Elbow Adapter, 45°, -4 ORFS/-4 O-Ring	
47	FS2603-04-04-04	1	Union Tee Adapter, -4 ORFS/-4 ORFS/-4 ORFS	
48	FS2700-12-12	4	Bulkhead Union Adapter, -12 ORFS/-12 ORFS	
49	FS0306-12	1	Bulkhead Lock Nut, -12 ORFS	
50	FS2704-04-04-04-FG	1	Run Tee Bulkhead Adapter, -4 ORFS (x3)	
51	FS0306-04	1	Bulkhead Lock Nut, -4 ORFS	
52	FS2704-12-12-12-FG	1	Run Tee Bulkhead Adapter, -12 ORFS (x3)	
53	FS6500-12-12-FG	1	Swivel Elbow Adapter, 90°, -12 ORFS/-12 ORFS	
54	FS6602-12-12-12-FG	1	Swivel Run Tee Adapter, -12 ORFS (x3)	
55	FS2406-12-10	2	Straight Reducer Adapter, -12 FFORX/-10 ORFS	
REF	1016860	1	Track Tensioner Hose Kit	Not Shown
REF	1016854	1	Drive Motors Hose Kit	Not Shown
GRP	1017205		Group - Cast Steel Drive	
REF	1009739	1	Steel Track/Undercarriage Assembly - Right	Not Shown, Includes Item 2a
REF	1009738	1	Steel Track/Undercarriage Assembly - Left	Not Shown, Includes Item 2b
REF	851101	2	Track Assembly w/Cast Steel Pads	Not Shown, Includes Items 30-39, 49
56	811304	A/R	Cast Steel Track Pad	

Illustrated Parts List

TRACK ASSEMBLY - CONTINUOUS RUBBER (1 OF 2)

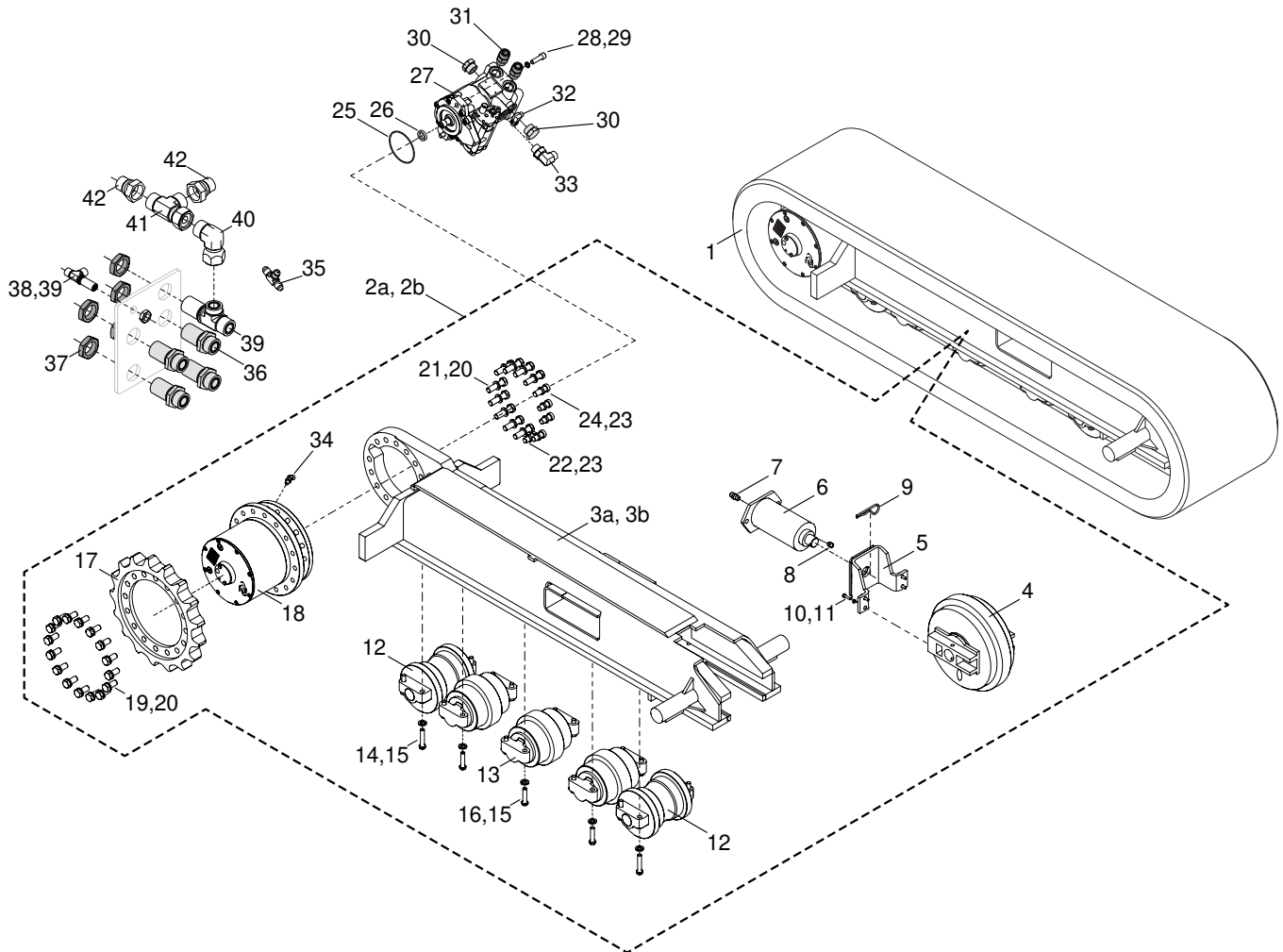

Figure 7-2. Track Assembly - Continuous Rubber (1 of 2)

Track Assembly - Continuous Rubber (1 of 2)

Item No	Part Number	Qty	Description	Remarks
GRP	1017204		Group - Rubber Track Drive	
REF	1009874	1	Rubber Track/Undercarriage Assembly - Right	Includes Item 2a
REF	1009873	1	Rubber Track/Undercarriage Assembly - Left	Not Shown; Includes Item 2b
1	982585	2	Continuous Rubber Track	
2a	1009468	1	Undercarriage Assembly - Right	Includes Item 3a
2b	1009467	1	Undercarriage Assembly - Left	Not Shown; Includes Item 3b
3a	1009466	1	Undercarriage Weldment - Right	
3b	1009465	1	Undercarriage Weldment - Left	Not Shown
4	983530	2	Front Idler	
5	811329ASRV	2	Front Track Idler Yoke, Short	
6	1016146-02	2	Cylinder, Track Tensioner	
REF	811331-01	A/R	Seal Kit, Track Tensioner Cylinder	Not Shown
7	FS2404-10-8	2	Connector Adapter, -10 ORFS/ -8 NPTF	
8	851644	2	Track Tensioner Cylinder Breather	Included with Item 6
9	870307	2	Cotter Pin, .177, 7 GA	
10	100-4-20-16-5F	8	CSSH, 1/4-20 x 1.00, GR5, FT	
11	302-4	8	Washer, Lock, 1/4	
12	851566	4	Undercarriage Roller	
12	983588	6	Track Roller, B/1, Inner Flange	
14	100-M12-1.75-60-8.8F	16	CSHH, M12x1.75 x 60, C8.8, FT	
15	302-9	A/R	Washer, Lock, 9/16	
16	100-M12-1.75-50-8.8F	A/R	CSHH, M12x1.75 x 50, C8.8, FT	
17	1009464	2	Rubber Track Sprocket (Comer)	
18	1008779	2	Torque Hub w/Disconnect (Comer)	
19	100-M16-2-35-8.8F	32	CSHH, M16x2 x 35, C8.8, FT	
20	302-10	A/R	Washer, Lock, 5/8	
21	100-M16-2-60-8.8F	18	CSHH, M16x2 x 60, C8.8, FT	
22	1008895	8	Low Socket Cap Screw, M16x2 x 35	
23	307-10	10	Washer, Lock, Hi-Collar, 5/8	
24	1008903	2	Low Socket Cap Screw, M16x2 x 45	
25	811366	2	O-Ring, Hydraulic Motor to Torque Hub	
26	59941203	A/R	Seal, Hydraulic Drive Motor	
27	811362	2	Hydraulic Drive Motor, 2-Speed	
REF	851494	1	Pump Servo Motor Gasket	Not Shown
28	102-M12-1.75-40-8.8F	4	CSSH, M12x1.75 x 40, C8.8, FT	
29	307-M12	4	Washer, Lock, Hi-Collar, M12	
30	6408-16-0	4	Plug Adapter, -16 O-Ring	
31	FS6400-12-12-O	4	Straight Adapter, -12 ORFS/-12 ORFS	
32	FS6801-04-06-NWO-FG	2	Elbow Adapter, 90°, -4 ORFS/-6 O-Ring	
33	FS6801-10-12-NWO-FG	2	Elbow Adapter, 90°, -10 ORFS/-12 O-Ring	

Illustrated Parts List

TRACK ASSEMBLY - CONTINUOUS RUBBER (2 OF 2)

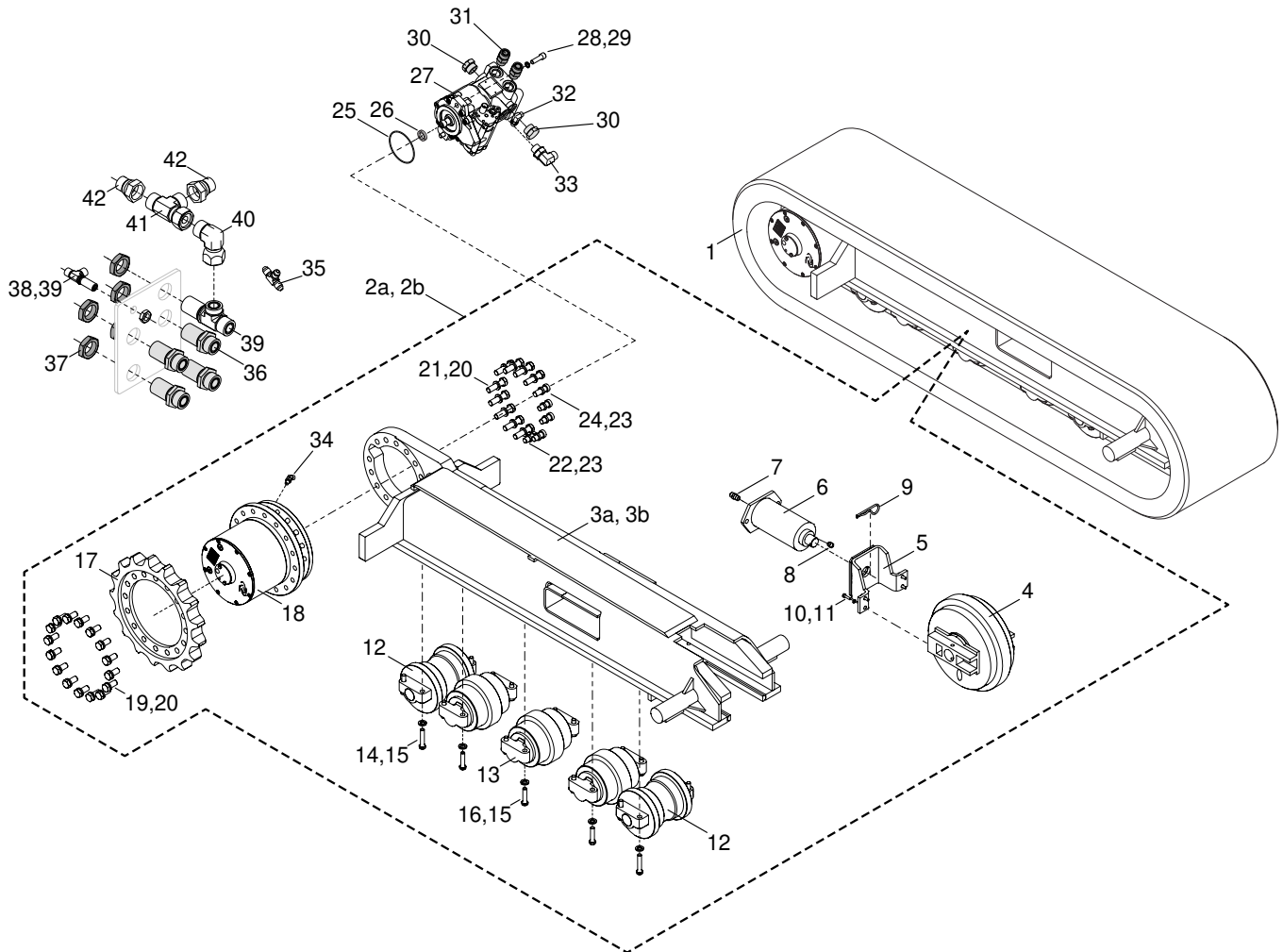

Figure 7-2. Track Assembly - Continuous Rubber (2 of 2)

Track Assembly - Continuous Rubber (2 of 2)

Item No	Part Number	Qty	Description	Remarks
34	FS6802-04-04-NWO-FG	2	Elbow Adapter, 45°, -4 ORFS/-4 O-Ring	
34	FS2603-04-04-04	1	Union Tee Adapter, -4 ORFS/-4 ORFS/-4 ORFS	
35	FS2700-12-12	4	Bulkhead Union Adapter, -12 ORFS/-12 ORFS	
36	FS0306-12	1	Bulkhead Lock Nut, -12 ORFS	
37	FS2704-04-04-04-FG	1	Run Tee Bulkhead Adapter, -4 ORFS (x3)	
38	FS0306-04	1	Bulkhead Lock Nut, -4 ORFS	
39	FS2704-12-12-12-FG	1	Run Tee Bulkhead Adapter, -12 ORFS (x3)	
40	FS6500-12-12-FG	1	Swivel Elbow Adapter, 90°, -12 ORFS/-12 ORFS	
41	FS6602-12-12-12-FG	1	Swivel Run Tee Adapter, -12 ORFS (x3)	
42	FS2406-12-10	2	Straight Reducer Adapter, -12 FFORX/-10 ORFS	
REF	1016860	1	Track Tensioner Hose Kit	Not Shown
REF	1016854	1	Drive Motors Hose Kit	Not Shown

Illustrated Parts List

PUSH BAR ASSEMBLY

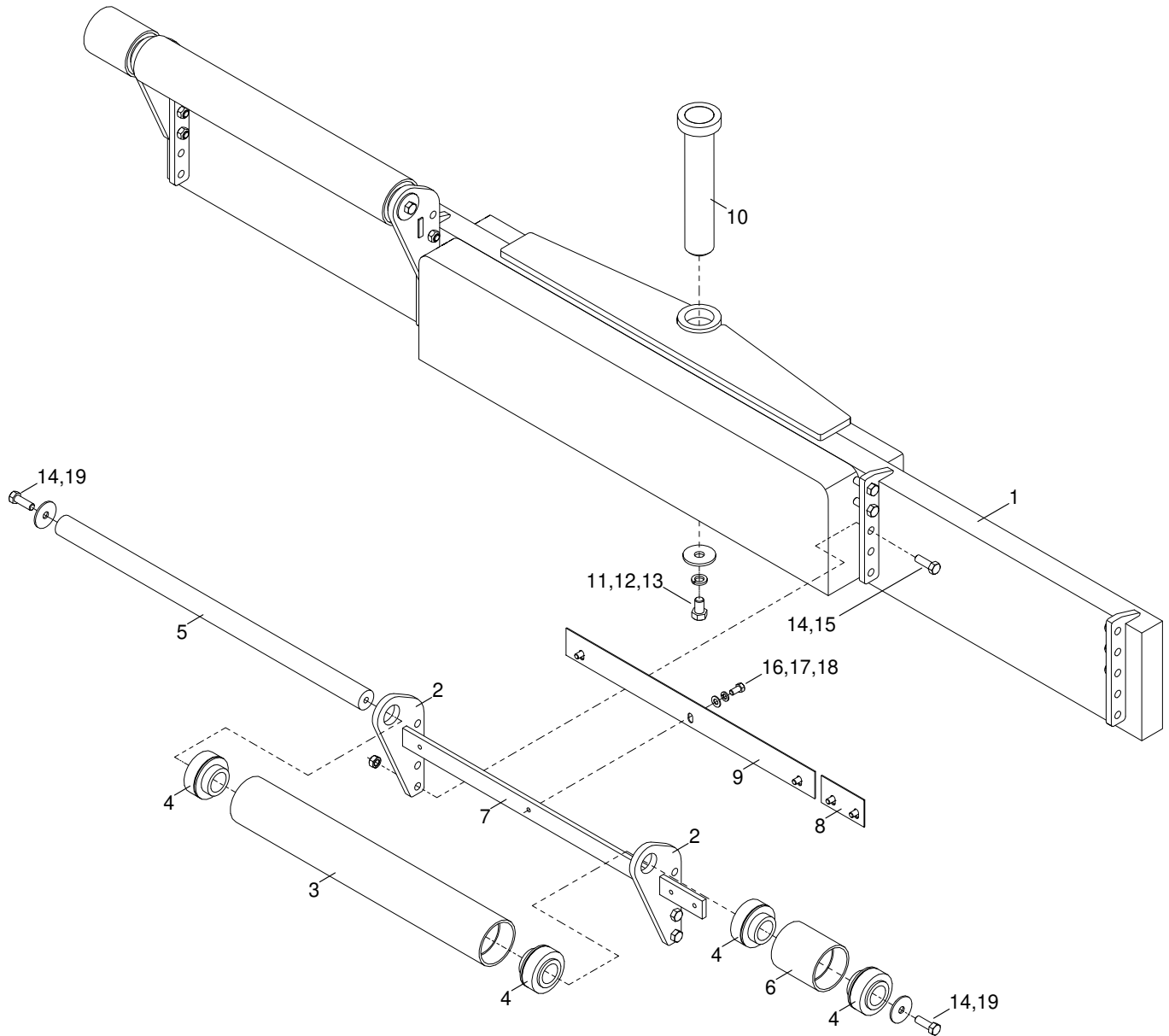

Figure 7-3. Push Bar Assembly

Push Bar Assembly

Item No	Part Number	Qty	Description	Remarks
GRP	1017211	1	Group - Adjustable Pushbar w/Counterweight	Includes Items 1 - 9
1	1016888	1	Push Roller Weldment	
2	1016324	4	Adjustable Roller Mount Plate	
REF	980033	2	Pushbar Roller Assembly, 24"	Includes Items 3,4
3	980033-1	2	Roller Push Tube	(1) Per Assembly
4	850130	8	Insert Bearing, 1.50	(2) Per Assembly
5	980034	2	Pushbar Roller Shaft	
REF	980035	2	Pushbar Roller Assembly	Includes Items 4, 6
6	980036	2	Pushbar Roller Extension Pipe	(1) Per Assembly
7	1018312	2	Roller Scraper Bracket - Large	
8	1018311	2	Roller Scraper - Small	
9	1018310	2	Roller Scraper - Large	
10	810081SRV	1	Pushbar Swivel Pin	
11	100-10-11-16-5F	1	CSHH, 5/8-11 x 1.00, GR5, FT	
12	302-10	1	Washer, Lock, 5/8	
13	1012165	1	Washer, Flat, .688 x 2.25 x .188	
14	100-8-13-24-5	16	CSHH, 1/2-13 x 1.50, GR5	
15	204-8-13-5	12	Nut, Lock, Stover, 1/2-13, GR5	
16	100-6-16-12-5F	10	CSHH, 3/8-16 x .75, GR5, FT	
17	302-6	10	Washer, Lock, 3/8	
18	300-6	10	Washer, Flat, SAE, 3/8	
19	1017118	4	Washer, .50 ID x 2.00 OD	
OPT	1011041	1	OPTION - Adjustable Push Roller Assembly	Not Shown

Illustrated Parts List

CONVEYOR ASSEMBLY (1 OF 2)

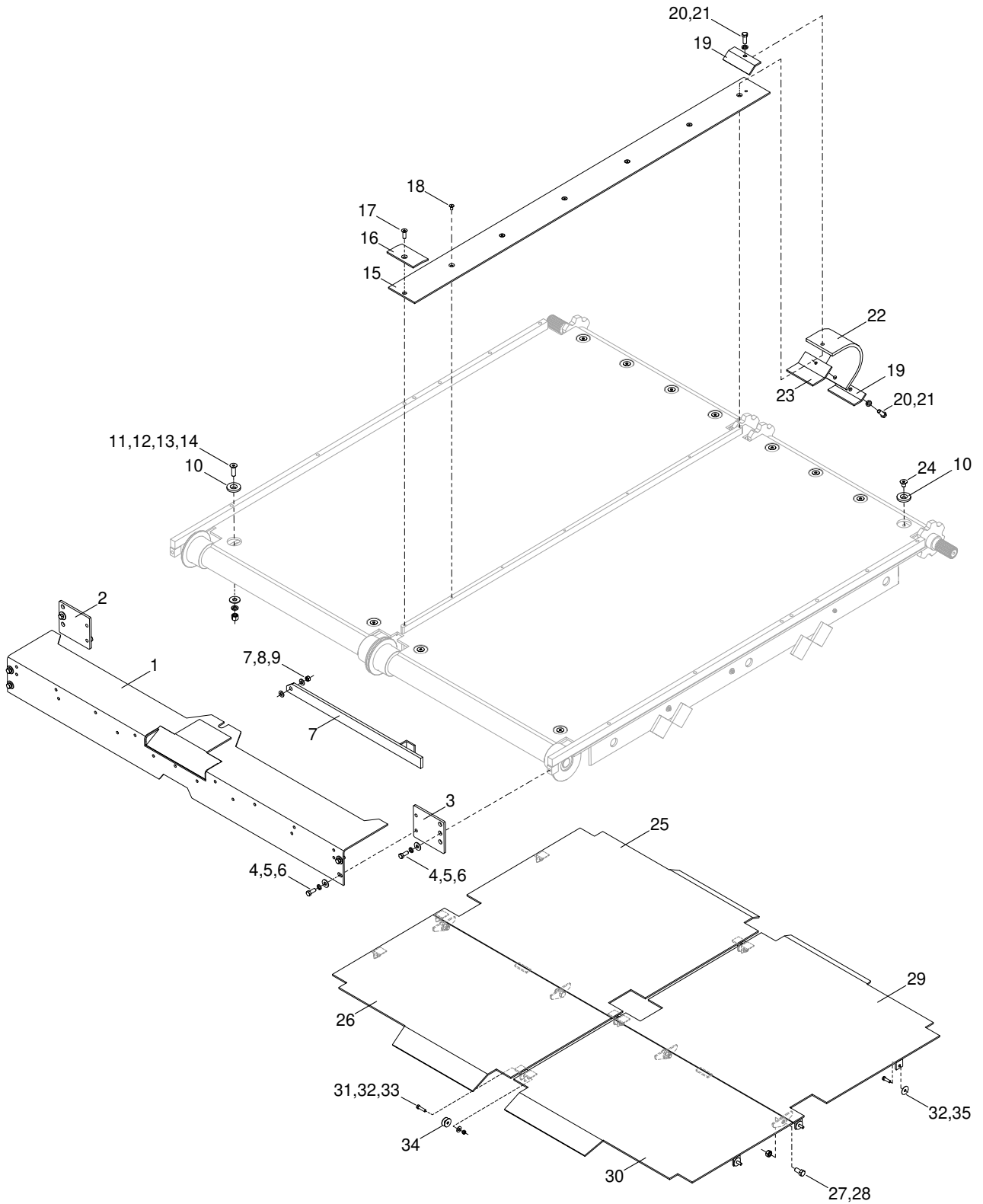

Figure 7-4. Conveyor Assembly (1 of 2)

Conveyor Assembly (1 of 2)

Item No	Part Number	Qty	Description	Remarks
GRP	1017200		Group - Conveyor Assembly	
1	985669SRV	1	Front Lip Guard Assembly	
2	1013152SRV	1	Front Lip Weldment - Right	
3	1013153SRV	1	Front Lip Weldment - Left	
4	100-8-13-20-5F	6	CSHH, 1/2-13 x 1.25, GR5, FT	
5	302-8	6	Washer, Lock, 1/2	
6	301-8	6	Washer, Flat, USS, 1/2	
7	1016760	1	Hopper Safety Rod Weldment	
8	204-8-13-5	1	Nut, Lock, Stover, 1/2-13, GR5	
9	300-8	2	Washer, Flat, SAE, 1/2	
10	855346	12	Conveyor Plate Washer	
11	105-10-11-32-F	4	CSFHS, 5/8-11 x 2.00, FT	
12	301-10	4	Washer, Flat, USS, 5/8	
13	302-10	4	Washer, Lock, 5/8	
14	216-10-11-5	4	Nut, Hex, Thick, 5/8-11, GR5	
15	851133SRV	1	Conveyor Center Cover	
16	985581	1	Front Lip Clamp	
17	105-8-13-24-F	1	CSFHS, 1/2-13 x 1.50, FT	
18	105-6-16-12-F	5	CSFHS, 3/8-16 x .75, FT	
19	802112SRV	1	Guard Clamp	
20	100-9-12-24-5F	2	CSHH, 9/16-12 x 1.50, GR5, FT	
21	302-9	2	Washer, Lock, 9/16	
22	840162	1	Conveyor Center Rear Rubber	
23	802114	1	Conveyor Center Weld Plate	
24	105-10-11-14-F	8	CSFHS, 5/8-11 x .875, FT	
REF	851127RSRV	1	Conveyor Bottom Pan - Right	Includes Items 25-28
25	855878	1	Conveyor Pan, Rear - Right	
26	855879	1	Conveyor Pan, Front - Right	
27	100-10-11-20-5F	4	CSHH, 5/8-11 x 1.25, GR5, FT	
28	204-10-11-5	4	Nut, Lock, Stover, 5/8-11, GR5	
REF	851127LSRV	1	Conveyor Bottom Pan - Left	Includes Items 27-30
29	855881	1	Conveyor Pan, Rear - Left	
30	855882	1	Conveyor Pan, Front - Left	
31	100-6-16-24-5F	3	CSHH, 3/8-16 x 1.50, GR5, FT	
32	301-6	9	Washer, Flat, USS, 3/8	
33	204-6-16-5	3	Nut, Lock, Stover, 3/8-16, GR5	
34	981511	18	Fender Washer, 3/8	
35	100-6-16-20-5F	12	CSHH, 3/8-16 x 1.25, GR5, FT	

Illustrated Parts List

CONVEYOR ASSEMBLY (2 OF 2)

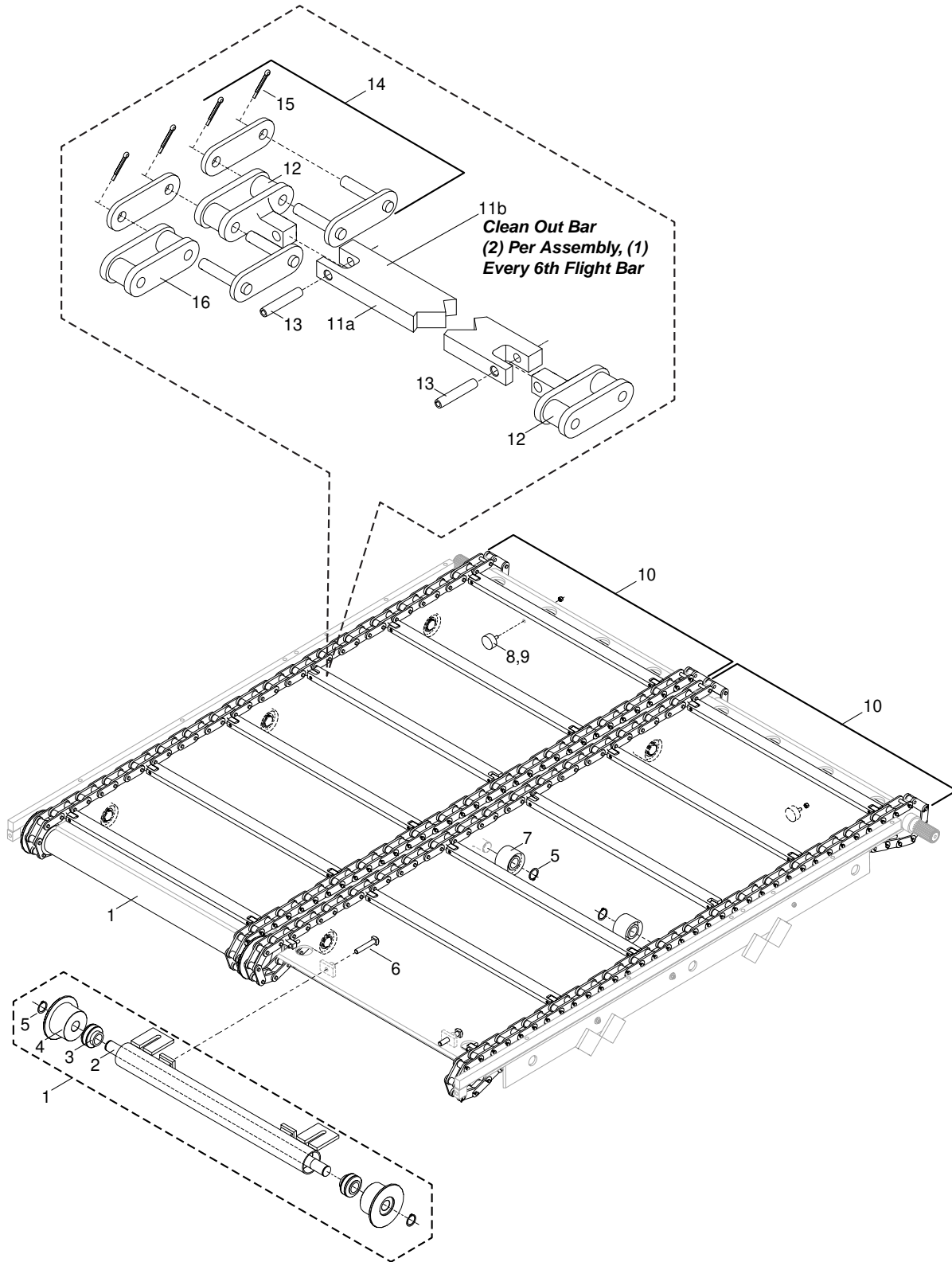

Figure 7-5. Conveyor Assembly (2 of 2)

Conveyor Assembly (2 of 2)

Item No	Part Number	Qty	Description	Remarks
GRP	1017200		Group - Conveyor Assembly	
1	851123	2	Conveyor Front Guide Tube Assembly	Includes Items 2-5
2	851124	2	Conveyor Idler Shaft	
3	520060	4	Bearing Insert, Setscrew Locking	
4	850120	4	Conveyor Front Guide Wheel	
5	850040	16	Conveyor Drive Shaft Snap Ring	
6	124-10-11-56F	4	CSSQH, 5/8-11 x 3.50, FT	
7	850162	12	Conveyor Chain Idler Roller	
8	410070	2	Conveyor Bumper	
9	200-6-16-5	2	Nut, Hex, 3/8-16, GR5	
10	1016941SRV	2	Conveyor Chain Assembly w/Clean Out Bars	
11a	851118A	20	Conveyor Flight Chain Bar	
11b	1014959	4	Conveyor Flight Clean Out Bar	(2) Per Assembly
12	850080B	A/R	Conveyor Chain Link w/Tab	
13	400-6-32	A/R	Roll Pin, 3/8 x 2.00	
14	850070A	A/R	Conveyor Chain Master Link	
15	850100A	A/R	Conveyor Chain T-Pin	
16	850080	A/R	Conveyor Chain Block Link	
REF	850215A	A/R	Conveyor Chain Offset Link	Not Shown
REF	851627SRV	A/R	Conveyor Floor Plate	Not Shown

Illustrated Parts List

CONVEYOR DRIVE & PADDLE ASSEMBLY (1 OF 2)

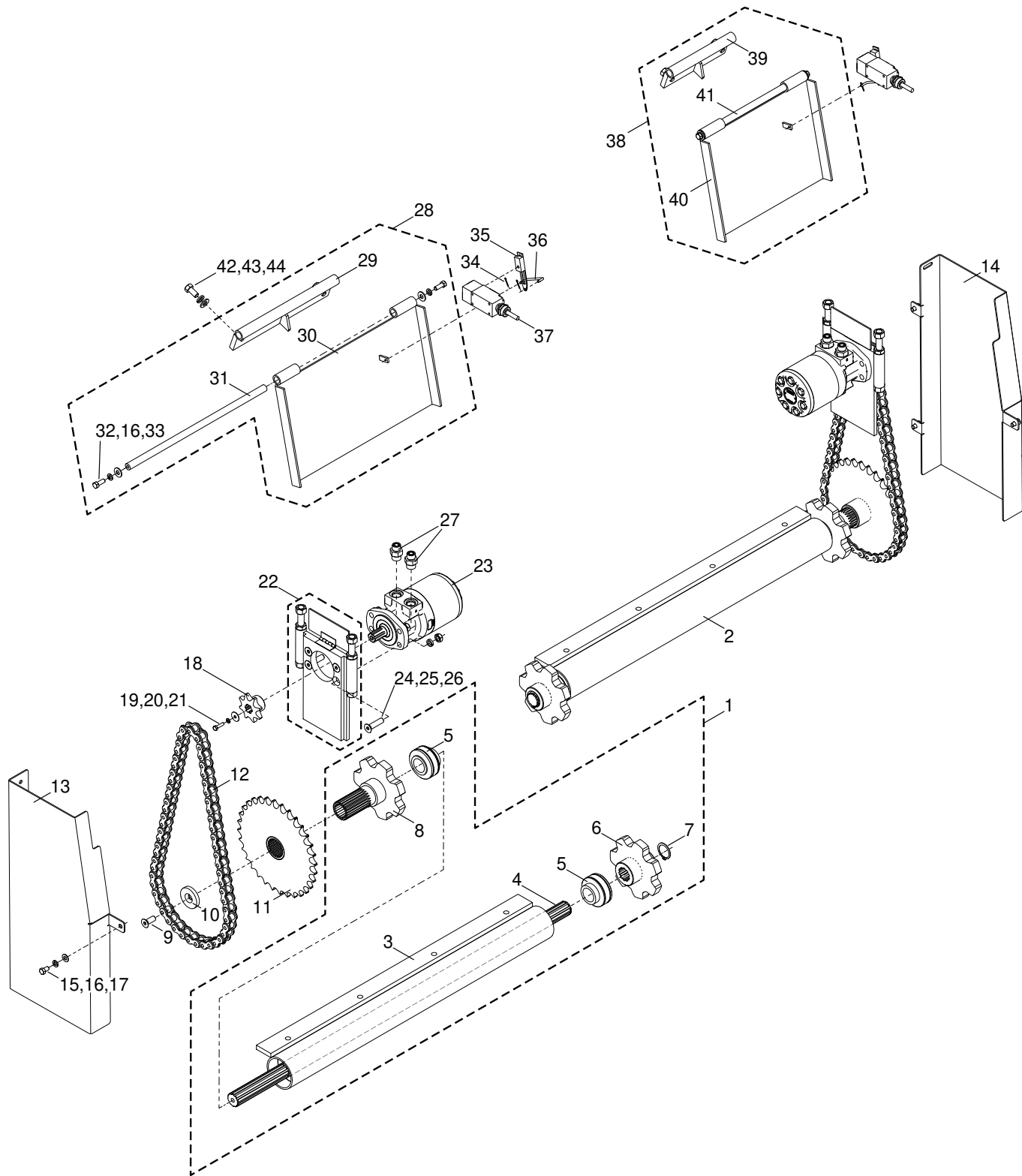

Figure 7-6. Conveyor Drive & Paddle Assembly (1 of 2)

Conveyor Drive & Paddle Assembly (1 of 2)

Item No	Part Number	Qty	Description	Remarks
GRP	1017200		Group - Conveyor Assembly	
1	987712	1	Rear Tube Drive Assembly - Left	Includes Items 3-8
2	987713	1	Rear Tube Drive Assembly - Right	Includes Items 3-8
3	851651	2	Conveyor Tube Assembly	Includes Item 5
4	851116	2	Conveyor Drive Shaft	
5	520060	4	Bearing Insert, Locking Set Screw	
6	850030SRV	2	Inner Conveyor Drive Sprocket	
7	850040	2	Conveyor Drive Shaft Snap Ring	
8	851474SRV	2	Outer Conveyor Drive Sprocket	
9	105-8-13-16-F	2	CSFHS, 1/2-13 x 1.00, FT	
10	851112	2	Conveyor Drive Sprocket Washer	
11	1019092	2	Conveyor Drive Sprocket	
12	1019094	2	Roller Chain, 80 x 56 Pitch	
13	1019047SRV	1	Conveyor Chain Guard Weldment - Left	
14	1019048SRV	1	Conveyor Chain Guard Weldment - Right	
15	100-6-16-10-5F	6	CSHH, 3/8-16 x .625, GR5, FT	
16	302-6	10	Washer, Lock, 3/8	
17	300-6	6	Washer, Flat, SAE, 3/8	
18	851120	2	Conveyor Drive Motor Sprocket	
19	100-4-20-16-5F	2	CSHH, 1/4-20 x 1.00, GR5, FT	
20	302-4	2	Washer, Lock, 1/4	
21	308-4-16	2	Washer, Flat, Fender, 1/4 x 1.00	
22	1014196	2	Conveyor Drive Tension Adjuster Weldment	
23	260130	2	Hydraulic Motor, 22.0 CIR	
24	105-8-13-32-F	8	CSFHS, 1/2-13 x 2.00, GR5, FT	
25	307-8	8	Washer, Lock, Hi-Collar, 1/2	
26	202-8-13-5	8	Nut, Hex, Jam, 1/2-13, GR5	
27	FS6400-08-10-O	4	Straight Adapter, -8 ORFS/-10 O-Ring	
28	1016523SRV	1	Conveyor Cutoff Assembly - Left	Includes 16,29-34
29	1016522	1	Conveyor Cutoff Hinge Weldment - Left	
30	1016521	1	Conveyor Cutoff Flap Weldment - Left	
31	1015297	1	Conveyor Flap Hinge Pin - Left	
32	100-6-16-16-5F	4	CSHH, 3/8-16 x 1.00, GR5, FT	
33	301-6	4	Washer, Flat, USS, 3/8	
34	13A-0212ZI	4	Cotter Pin, 1/16 x 3/4 Plated	
35	900060-1SRV	2	Conveyor Switch Arm	
36	900075	2	Conveyor Switch Linkage, Rod	
37	900050SRV	2	Conveyor Automatic Micro Switch	

Illustrated Parts List

CONVEYOR DRIVE & PADDLE ASSEMBLY (2 OF 2)

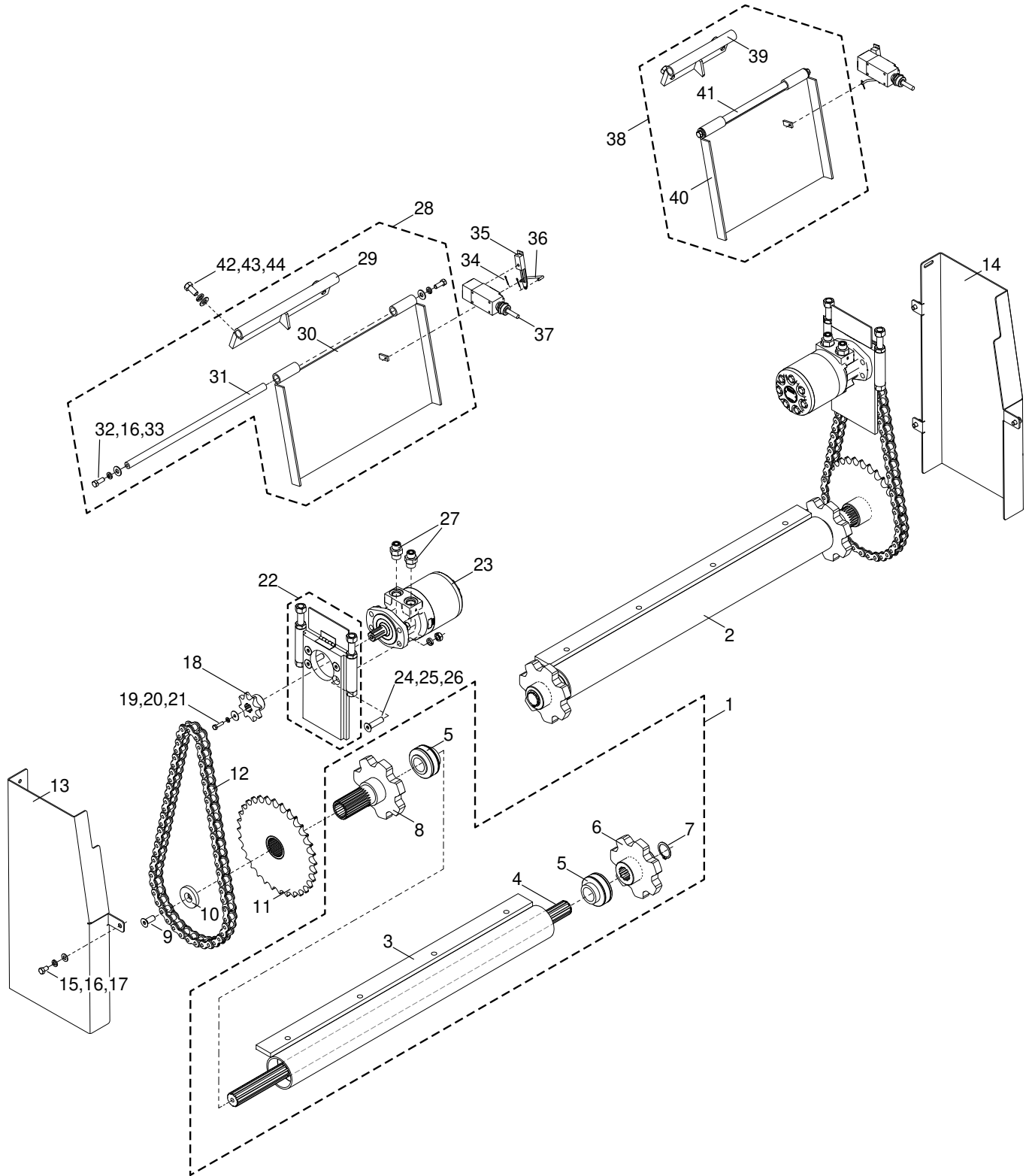

Figure 7-6. Conveyor Drive & Paddle Assembly (2 of 2)

Conveyor Drive & Paddle Assembly (2 of 2)

Item No	Part Number	Qty	Description	Remarks
38	1016524SRV	1	Conveyor Cutoff Assembly - Right	Includes Items 16,35-37,39-41
39	1016525	1	Conveyor Cutoff Hinge Weldment - Right	
40	1016526	1	Conveyor Cutoff Flap Weldment - Right	
41	1015298	1	Conveyor Flap Hinge Pin - Right	
42	100-8-13-16-5F	4	CSHH, 1/2-13 x 1.00, GR5, FT	
43	302-8	4	Washer, Lock, 1/2	
44	300-8	4	Washer, Flat, SAE, 1/2	

Hopper Wings

Item No	Part Number	Qty	Description	Remarks
1	980702SRV	1	Hopper Wing Weldment - Left	
2	980703SRV	1	Hopper Wing Weldment - Right	
3	980728	2	Sidewing Rubber	
4	980727	2	Hopper Wing Rubber Plate	
5	100-9-12-44-5	10	CSHH, 9/16-12 x 2.50, GR5	
6	301-9	10	Washer, Flat, USS, 9/16	
7	200-9-12-5	10	Nut, Hex, 9/16-12, GR5	
8	851143	2	Proof Coil Chain, .312 x 36 Link	
9	100-6-16-26-5F	2	CSHH, 3/8-16 x 1.625, GR5, FT	
10	300-6	2	Washer, Flat, SAE, 3/8	
11	200-6-16-5	2	Nut, Hex, 3/8-16, GR5	
12	610110	2	Hydraulic Cylinder, 2.00 x 8.22 x 1.00	
13	1011476	2	Clevis Pin, 1.00 x 2.50	
14	80336	2	Cotter Pin, .188 x 1.50	
15	855426	2	Hopper Wing Cylinder Bracket	
16	1014584	1	Access Door	
17	920070	8	Thumb Screw, 3/8-16 x 1.00	
18	985057	2	Front Lip Rubber - Outer	
19	985062	2	Side Strip Flashing	
20	985058	1	Front Lip Rubber - Center	
21	985063	1	Center Flashin	
22	100-7-20-32-5F	10	CSHH, 7/16-20 x 2.00, GR5, FT	
23	300-7	10	Washer, Flat, SAE, 7/16	
24	853887SRV	2	Guide Bar Assembly	
25	920041	2	Guide Bar Outer Tube	
26	920051	2	Guide Bar Inner Tube	
27	920061	2	Guide Bar	
28	920061-1	2	Proof Coil Chain, .250 x 12 Link	
29	100-6-16-20-5	2	CSHH, 3/8-16 x 1.25, GR5	
30	100-8-13-40-5	2	CSHH, 1/2-13 x 2.50, GR5	
31	300-8	2	Washer, Flat, SAE, 1/2	
32	204-8-13-5	2	Nut, Hex, Jam, 1/2-13, GR5	
33	854032	2	Pipe, .75 x 1.00, SCH 80	
34	1013877	2	Hopper Wing Lock Pin	
35	854084	2	Hopper Wing Hinge Pin	
36	6806-6-4 NWO	2	Elbow Adapter, 90°, -6 O-Ring/-4 NPTF	
37	20926564	2	Ball Valve, 1/4"	
38	FS2404-06-04	2	Straight Adapter, -6 ORFS/-4 NPTF	
39	FS6801-06-06-NWO-FG	2	Elbow Adapter, 90°, -6 ORFS/-6 O-Ring	

Illustrated Parts List

REAR AUGER ASSEMBLY (1 OF 2)

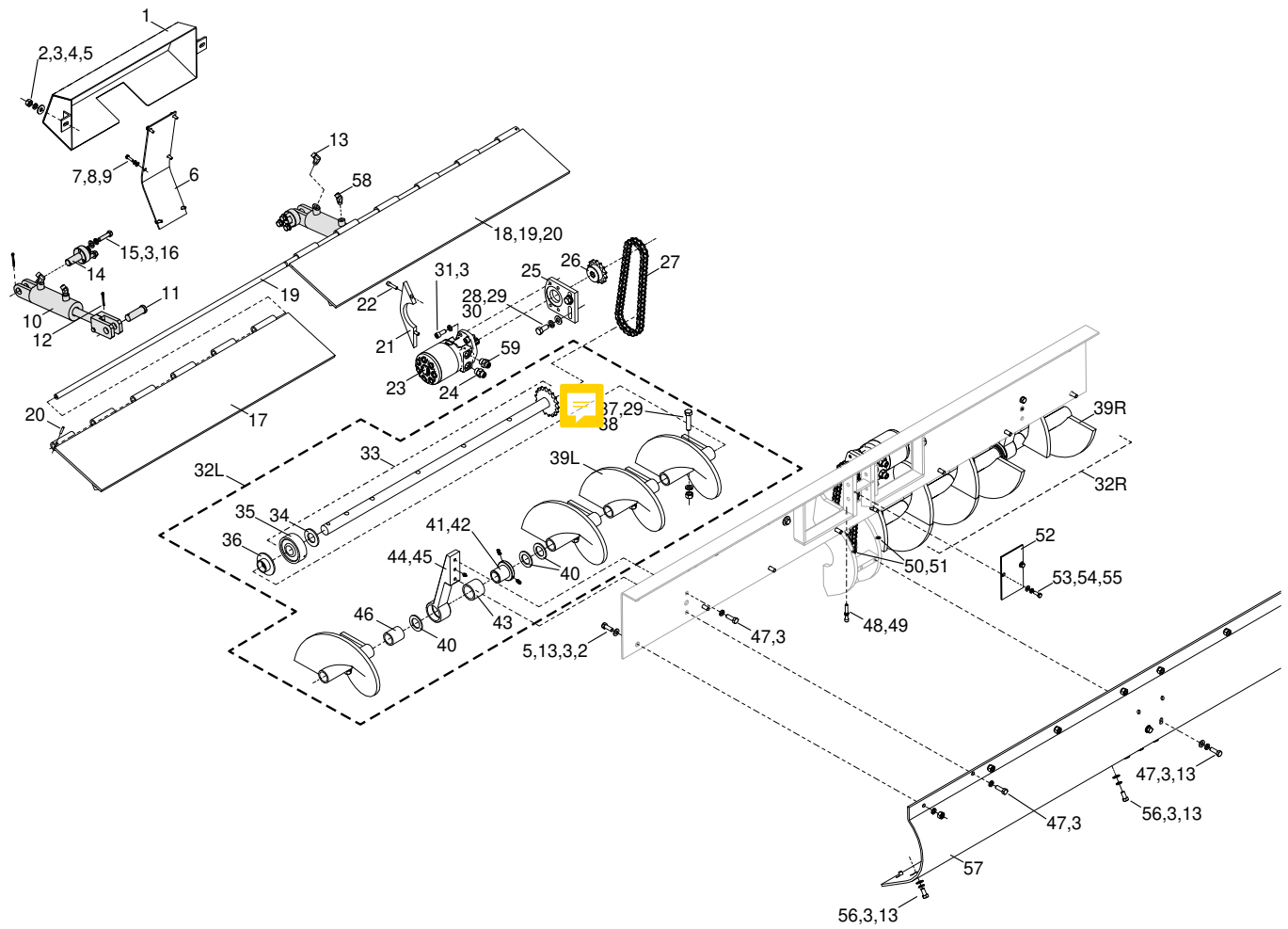

Figure 7-8. Rear Auger Assembly (1 of 2)

Rear Auger Assembly (1 of 2)

Item No	Part Number	Qty	Description	Remarks
1	981685	1	Auger Motor Cover Assembly	
2	201-8-13-5	10	Nut, Hex, Heavy, 1/2-13, GR5	
3	302-8	A/R	Washer, Lock, 1/2	
4	301-8	2	Washer, Flat, USS, 1/2	
5	100-8-13-22-5	10	CSHH, 1/2-13 x 1.375, GR5	
6	981695SRV	1	Auger Support Cover	
7	100-5-18-16-5	6	CSHH, 5/16-18 x 1.00, GR5	
8	302-5	6	Washer, Lock, 5/16	
9	300-5	6	Washer, Flat, SAE, 5/16	
10	910170	2	Hydraulic Cylinder, 2.50 x 4.00 x 1.25 Rod	Includes Items 11,12
11	240030	2	Clevis Pin, 1.00 x 3.25 w/1.50 Head	
12	80338	4	Cotter Pin, .188 x 2.00	
13	FS2501-06-06-FG	2	Elbow Adapter, 90°, -6 ORFS/ -6 NPTF	
14	1006988	2	Cut-Off Cylinder Mounting Shaft	
15	100-8-13-32-5	6	CSHH, 1/2-13 x 2.00, GR5	
16	300-8	A/R	Washer, Flat, SAE, 1/2	
17	1016517	1	Cut-Off Assembly - Left	
18	1016518	1	Cut-Off Assembly - Right	
19	1007064	2	Cut-Off Hinge Bar	
20	400-4-20	2	Roll Pin, 1/4 x 1.25	
21	1007269	2	Auger Clamp, 12"	
22	102-6-16-24-F	4	CSSH, 3/8-16 x 1.50, FT	
REF	1017640	2	Auger Motor Assembly	Includes 23,24
23	260130	2	Hydraulic Motor, 22.0 CIR	
24	FS6400-08-10-O	2	Straight Adapter, -8 ORFS/-10 O-Ring	
25	981696	2	Motor Mount	
26	860030	2	Sprocket, 60B 14 x 1-6 Spline	
27	985815	2	Roller Chain, 60H x 51 Pitch	
28	100-10-11-22-5F	4	CSHH, 5/8-11 x 1.375, GR5, FT	
29	302-10	12	Washer, Lock, 5/8	
30	300-10	4	Washer, Flat, SAE, 5/8	
31	102-8-13-20-F	8	CSSH, 1/2-13 x 1.25, FT	
32L	1019051	1	Auger Assembly w/Mount, 12" - Left	Includes Items 29,33-38,39L,40-46
32R	1019052	1	Auger Assembly w/Mount, 12" - Right	Includes Items 29,33-38,39R,40-46
33	1007270SRV	2	Shaft w/Sprocket, 12" Auger	Includes Items 34,35
34	1007323	2	Auger Bearing Spacer Washer	

Illustrated Parts List

REAR AUGER ASSEMBLY (2 OF 2)

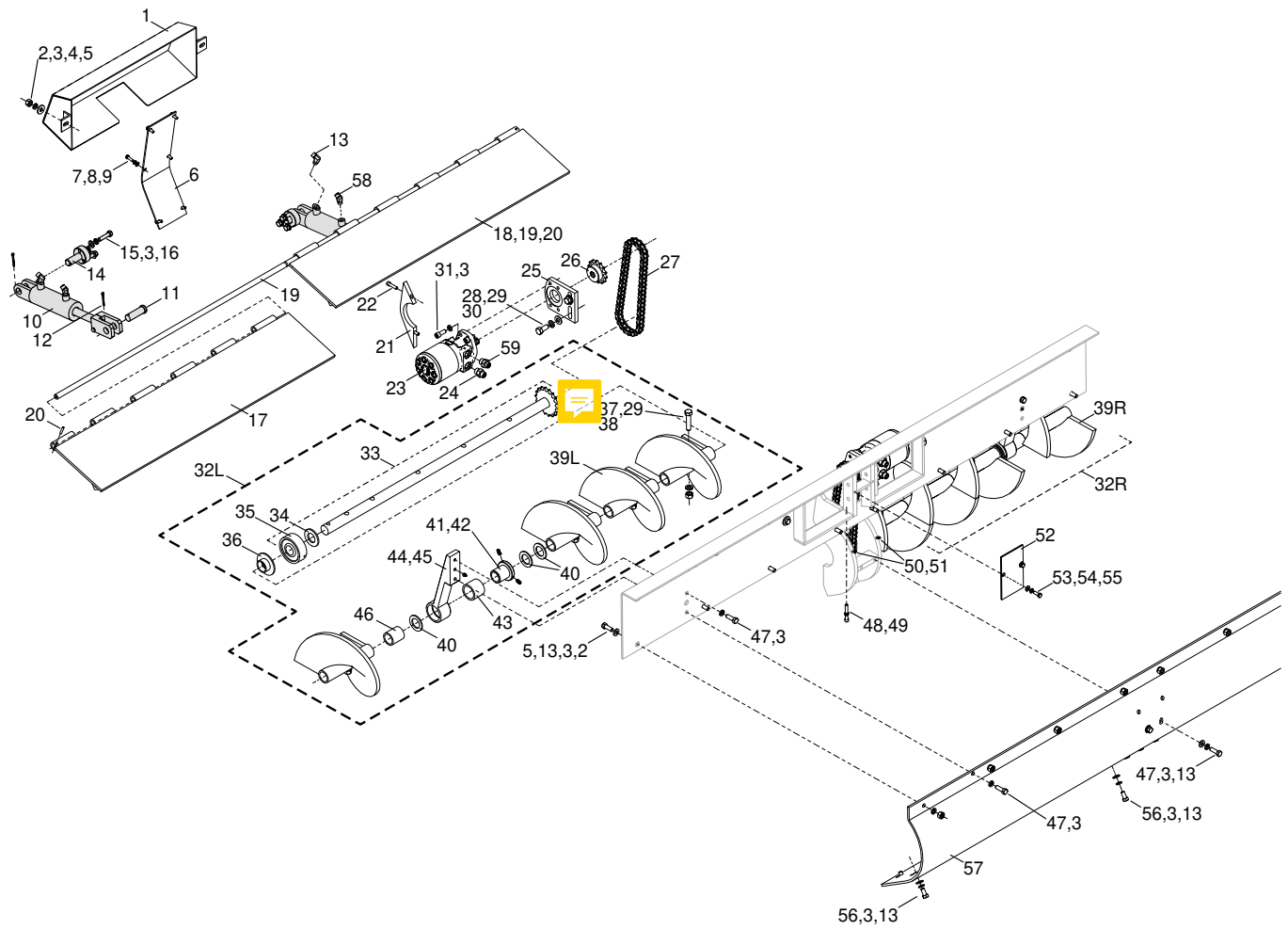

Figure 7-8. Rear Auger Assembly (2 of 2)

Rear Auger Assembly (2 of 2)

Item No	Part Number	Qty	Description	Remarks
35	1007267	2	Auger Bearing	
36	1007306	2	Auger Shaft Spacer Assembly	
37	100-10-11-44-5	8	CSHH, 5/8-11 x 1.75, GR5	
38	200-10-11-5	8	Nut, Hex, 5/8-11, GR5	
39L	981700L	4	Auger Flight, 12" - Left	
39R	981700R	4	Auger Flight, 12" - Right	
40	310-24	6	Washer, Hardened, SAE, 1-1/2"	
REF	1019053	2	Auger End Mount Assembly - Long	Includes Items 41-45
41	851645	2	Auger Shaft Collar	
42	1017379	4	Set Screw, 3/8-16 x .75, Knurl Cup Point	
43	810070	2	Bushing, 2.00 ID x 2.50 OD x 2.50	
44	1019053-01	2	Auger End Mount - Long	
45	29A-02	2	Grease Fitting, 1/8 NPT Straight	
46	1019051-01	2	Auger Spacer Tube	
47	100-8-13-24-5	4	CSHH, 1/2-13 x 1.50, GR5	
48	102-6-16-40	2	CSSH, 3/8-16 x 2.50	
49	202-6-16-5	2	Nut, Hex, Jam, 3/8-16, GR5	
50	1008949	2	Grease Fitting, 1/4-28, Long	
51	400-3-36	2	Roll Pin, 3/16 x 2.25	
52	981688SRV	1	Chain Cover	
53	100-6-16-16-5F	2	CSHH, 3/8-16 x 1.00, GR5, FT	
54	302-6	2	Washer, Lock, 3/8	
55	300-6	2	Washer, Flat, SAE, 3/8	
56	100-8-20-16-5F	8	CSHH, 1/2-20 x 1.00, GR5, FT	
57	1016721	1	Auger Back Wear Plate, 12"	
58	FS2503-06-06-FG	2	Elbow Adapter, 45°, -6 ORFS/-6 NPTF	
59	1019784	2	Check Valve, 140 PSI, -8 ORFS/10 O-Ring	

Illustrated Parts List

FUEL TANK ASSEMBLY

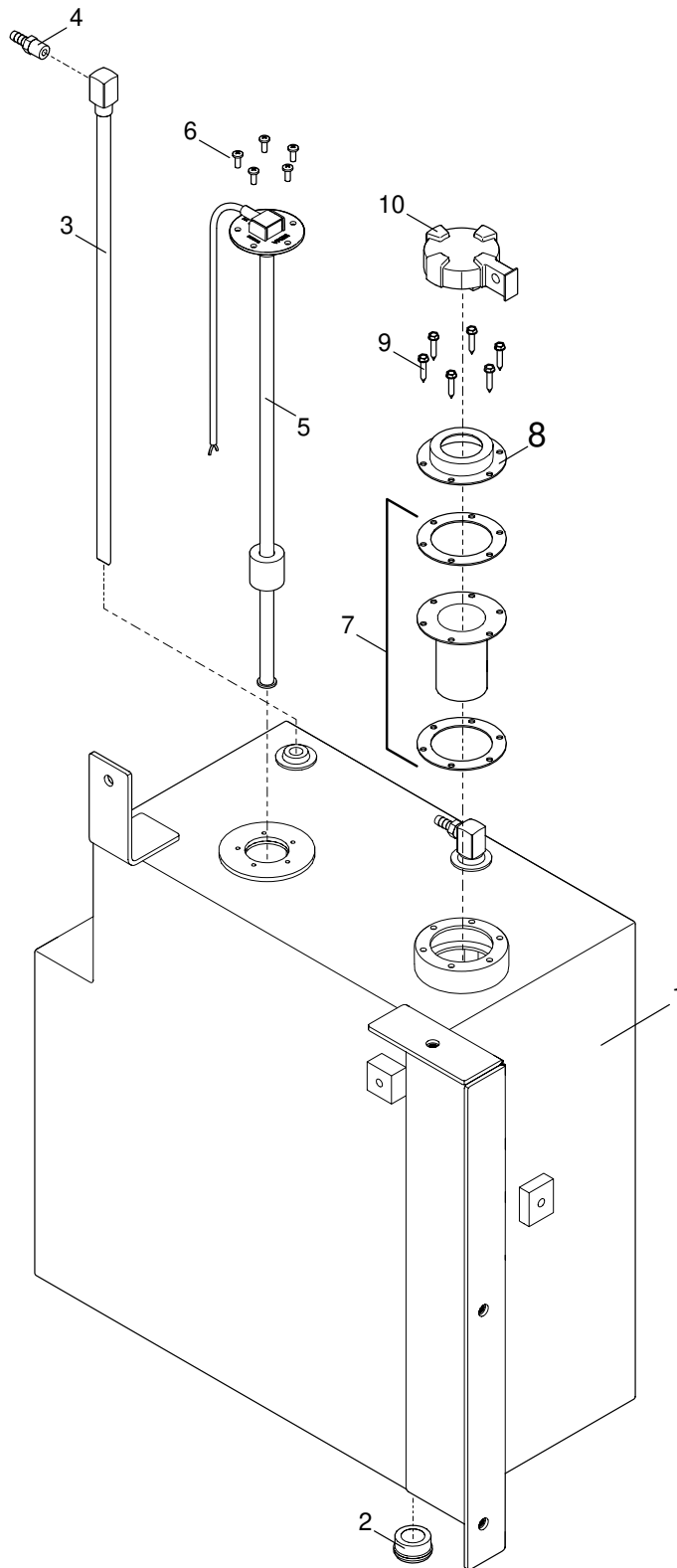

Figure 7-9. Fuel Tank Assembly

Fuel Tank Assembly

Item No	Part Number	Qty	Description	Remarks
REF	1016269	1	Fuel Tank Assembly	
1	1015904	1	Fuel Tank Weldment	
2	1011971	1	Magnetic Drain Plug, -16 SAE Orb	
3	1014538-20.5	2	Fuel Pick Up Tube	
4	33491	2	Straight Fitting, 04MP-05HB Crimped	
5	1016262	1	Fuel Sending Unit	
6	122-#10-24-8F	5	PHMS, Cross, #10-24 x .5, FT	
7	140030GK	1	Gasket/Strainer Kit	
8	140030FN	1	Filler Neck	
9	116-#10-16	6	Self-Drilling Screw, Hex Washer Head, #10 x 1.00	
10	140030FL	1	Lockable Cap, Fuel	

Illustrated Parts List

HYDRAULIC TANK ASSEMBLY

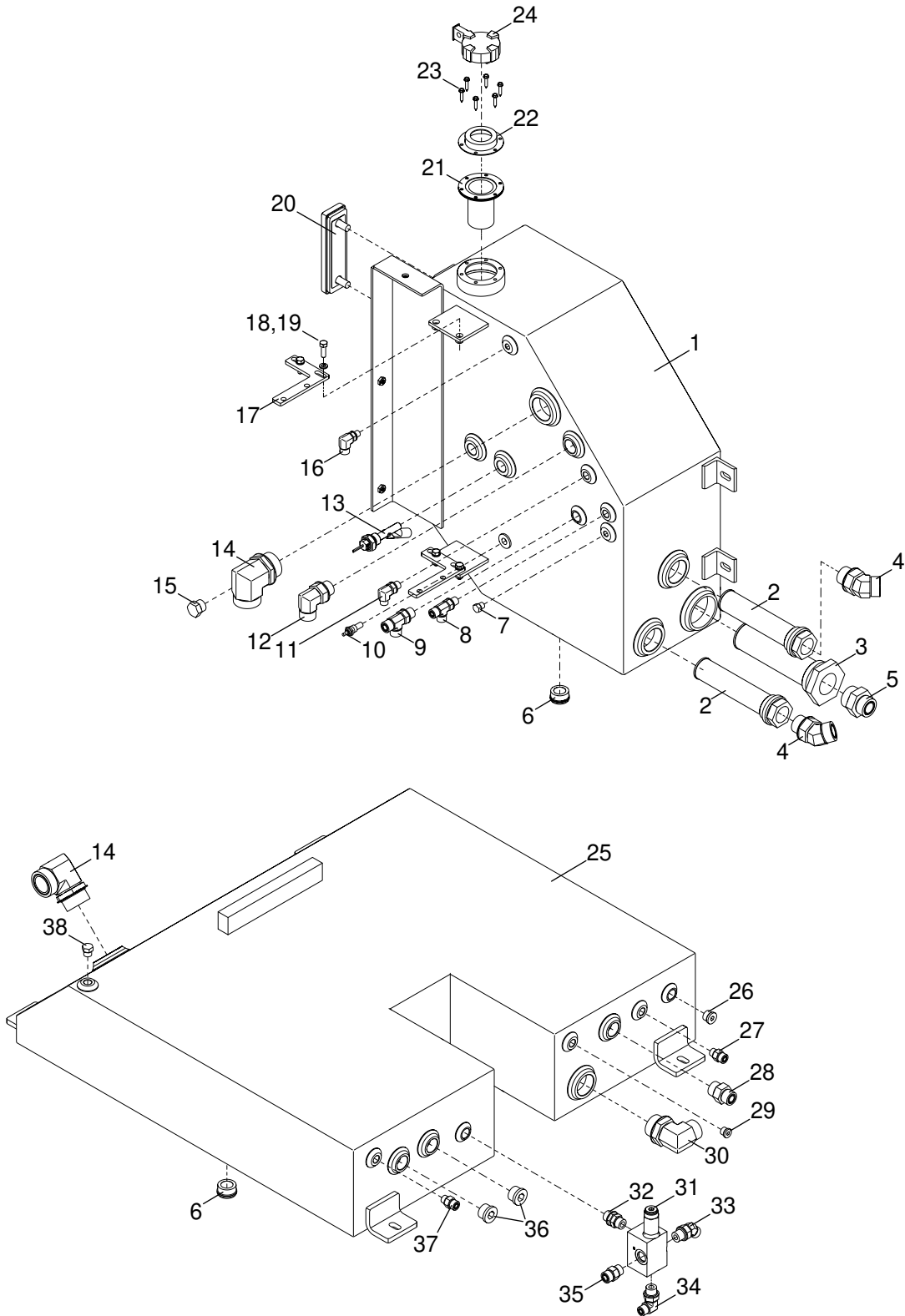

Figure 7-10. Hydraulic Tank Assembly

Hydraulic Tank Assembly

Item No	Part Number	Qty	Description	Remarks
REF	1019242	1	Top Hydraulic Tank Assembly	
1	1015883	1	Hydraulic Tank Weldment	
2	1011817	2	Hydraulic Suction Strainer, -24 SAE O-Ring	
3	1014037	1	Hydraulic Suction Strainer, 100 Mesh, O-Ring	
4	FS6802-16-16-NWO-FG	2	Elbow Adapter, 45°, -16 ORFS/-16 O-Ring	
5	FS6400-16-20-O	1	Straight Adapter, -16 ORFS/-20 O-Ring	
6	1011971	2	Magnetic Drain Plug, -16 SAE Orb	
7	6408-4-O	1	Plug Adapter, -4 O-Ring	
8	FS6804-06-06-06-NWO-FG	1	Run Tee Adapter, -6 ORFS (x3)	
9	FS6804-08-08-08-NWO-FG	1	Run Tee Adapter, -8 ORFS (x3)	
10	1010402	1	Hydraulic Oil Temperature Sender, 100-250°F	
11	FS6801-04-06-NWO-FG	1	Elbow Adapter, 90°, -4 ORFS/-6 O-Ring	
12	FS6801-12-12-NWO-FG	1	Elbow Adapter, 90°, -12 ORFS/-12 O-Ring	
13	1014643	1	Hydraulic Level Sensor	
14	FS6801-24-24-NWO-FG	2	Elbow Adapter, 90°, -24 ORFS/-24 O-Ring	
15	6408-10-O	1	Plug Adapter, -10 O-Ring	
16	FS6801-06-04-NWO-FG	1	Elbow Adapter, 90°, -6 ORFS/-4 O-Ring	
17	984528	2	Manifold Bracket Plate	
18	100-5-18-16-5	4	CSHH, 5/16-18 x 1.00, GR5	
19	302-5	4	Washer, Lock, 8/16	
20	500070	1	Hydraulic Oil Level/Temp Sight Gauge	
21	140030GK	1	Gasket/Strainer Kit	
22	140030FN	1	Filler Neck	
23	116-#10-16	6	Self-Drilling Screw, Hex Washer Head, #10 x 1.00	
24	140030HL	1	Lockable Cap, Hydraulic	
REF	1019241	1	Lower Hydraulic Tank Assembly	
25	1016275	1	Lower Hydraulic Tank Weldment	
26	6409-8-O	1	Plug Adapter, Hex Socket, -8 O-Ring	
27	FS6400-06-06-O	2	Straight Adapter, -6 ORFS/-6 O-Ring	
28	FS6400-10-12-O	1	Straight Adapter, -10 ORFS/-12 O-Ring	
29	6409-6-O	1	Plug Adapter, Hex Socket, -6 O-Ring	
30	FS6801-16-20-NWO-FG	1	Elbow Adapter, 90°, -16 ORFS/-20 O-Ring	
31	851544	1	Track Tensioner Manifold	
32	6407-8-8 NWO	1	Union Adapter, -8 O-Ring/-8 O-Ring	
33	FS6802-08-08-NWO-FG	1	Elbow Adapter, 45°, -8 ORFS/-8 O-Ring	
34	FS6801-06-08-NWO-FG	1	Elbow Adapter, 90°, -6 ORFS/-8 O-Ring	
35	FS6400-08-08-O	1	Straight Adapter, -8 ORFS/-8 O-Ring	
36	6409-12-O	2	Plug Adapter, Hex Socket, -12 O-Ring	
37	FS6400-06-06-O	1	Straight Adapter, -6 ORFS/-6 O-Ring	
38	6408-06-O	1	Plug Adapter, -6 O-Ring	

Illustrated Parts List

HYDRAULIC TEST PORTS

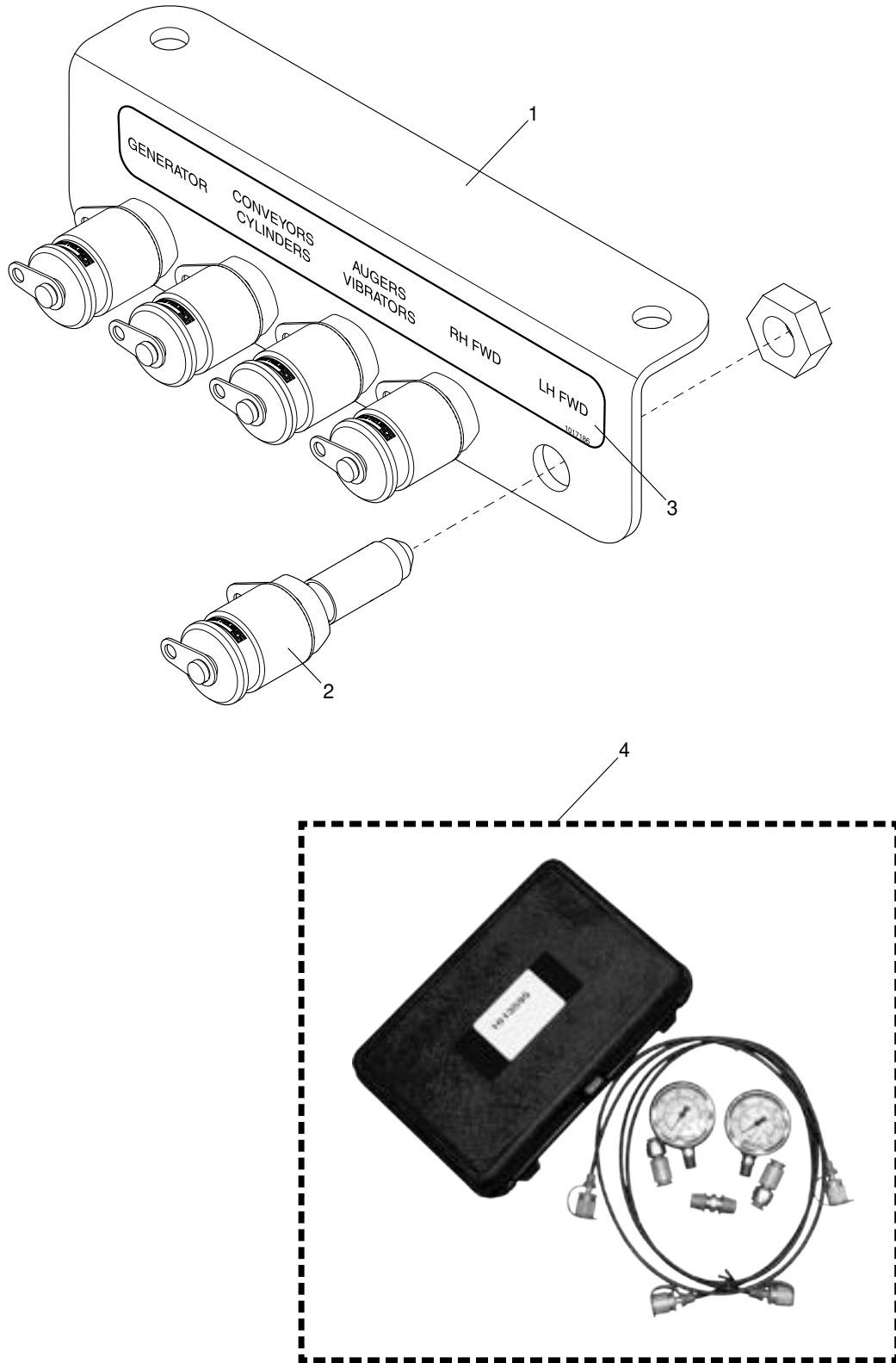

Figure 7-11. Hydraulic Test Ports

Hydraulic Test Ports

Item No	Part Number	Qty	Description	Remarks
1	1013805	1	Test Port Bracket	
2	1013583	1	Hydraulic Test to #4 JIC Bulkhead	
3	1017186	1	Decal - Test Port Info	
REF	1013588-24	1	SMS Test Hose Assembly w/#4 Female JIC - 24"	Not Shown
REF	1013588-96	1	SMS Test Hose Assembly w/#4 Female JIC - 96"	Not Shown
4	1013595	1	Hydraulic Pressure Test Kit	Option

Illustrated Parts List

ENGINE ASSEMBLY - RADIATOR

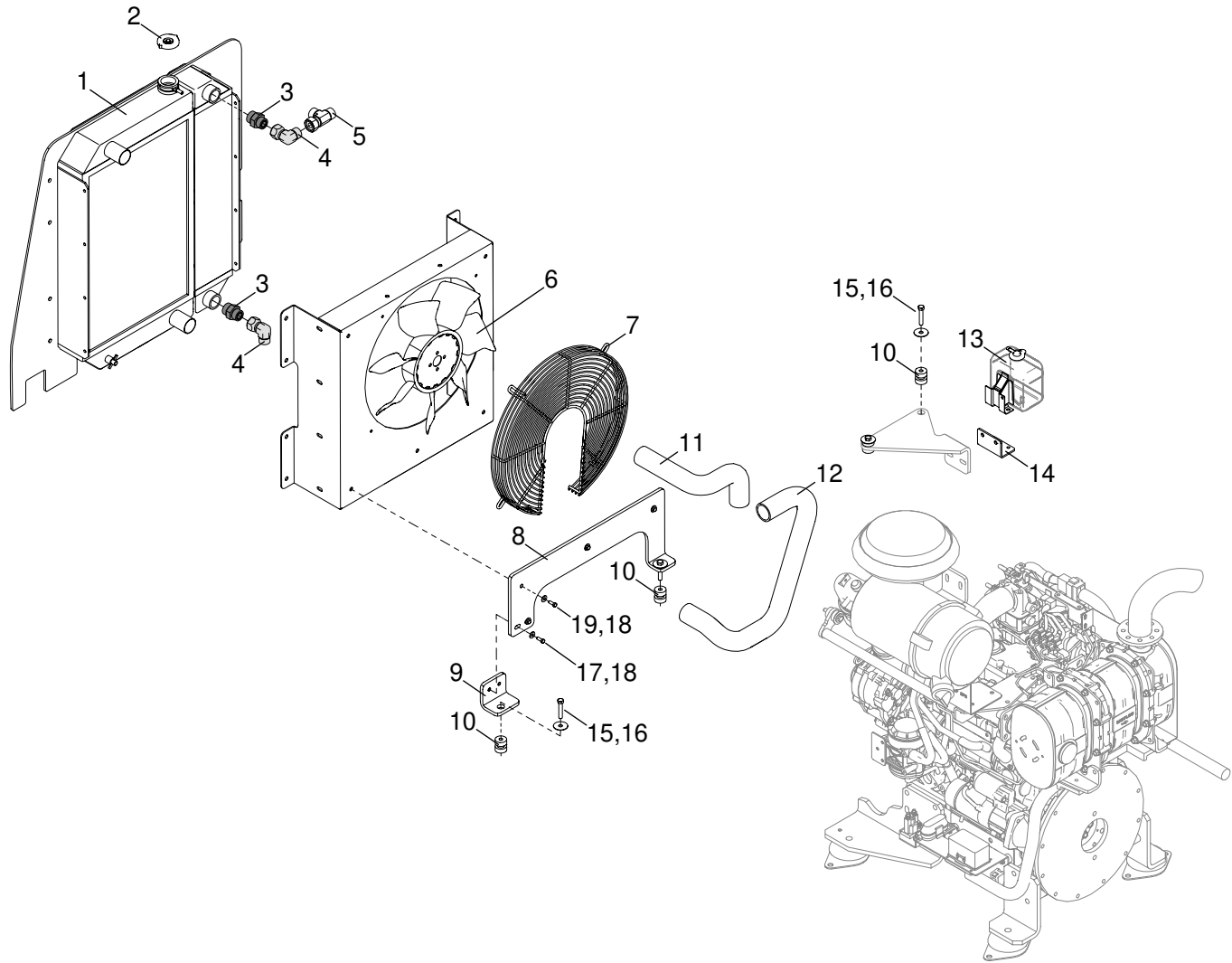

Figure 7-12. Engine Assembly - Radiator

Engine Assembly - Radiator

Item No	Part Number	Qty	Description	Remarks
REF	1016478	1	Kubota Engine, T4F, 74HP	
1	988673-13	1	Radiator/Cooler Assembly	
2	1002184-04	1	Radiator Cap	
3	FS6400-12-16-O	2	Straight Adapter, -12 ORFS/-16 O-Ring	
4	FS6500-12-12-FG	2	Elbow Adapter, 90°, -12 ORFS/-12 ORFS	
5	FS6602-12-12-12-FG	1	Swivel Run Tee Adapter, -12 ORFS/-12 ORFS/-12 ORFS	
6	1016478-01	1	Radiator Fan	
7	1005365-23	1	Radiator Fan Guard	
8	1009384-12	1	Lower Radiator Mount	
9	1009384-18	1	Radiator Support Bracket	
10	1001166-57	4	Radiator Mount Isolator	
11	1006963-15	1	Upper Radiator Hose	
12	1006963-16	1	Lower Radiator Hose	
13	986537-46	1	Coolant Recovery Tank	
14	1009384-08	1	Recovery Tank Bracket	
15	100-6-16-32-5	4	CSHH, 3/8-16 x 2.00, GR5	
16	308-6-24	4	Washer, Fender, 3/8 x 1.50	
17	100-6-16-16-5F	2	CSHH, 3/8-16 x 1.00, GR5, FT	
18	301-6	5	Washer, Flat, USS, 3/8	
19	100-6-16-12-5F	3	CSHH, 3/8-16 x .75, GR5, FT	

Illustrated Parts List

ENGINE ASSEMBLY - INTAKE/EXHAUST

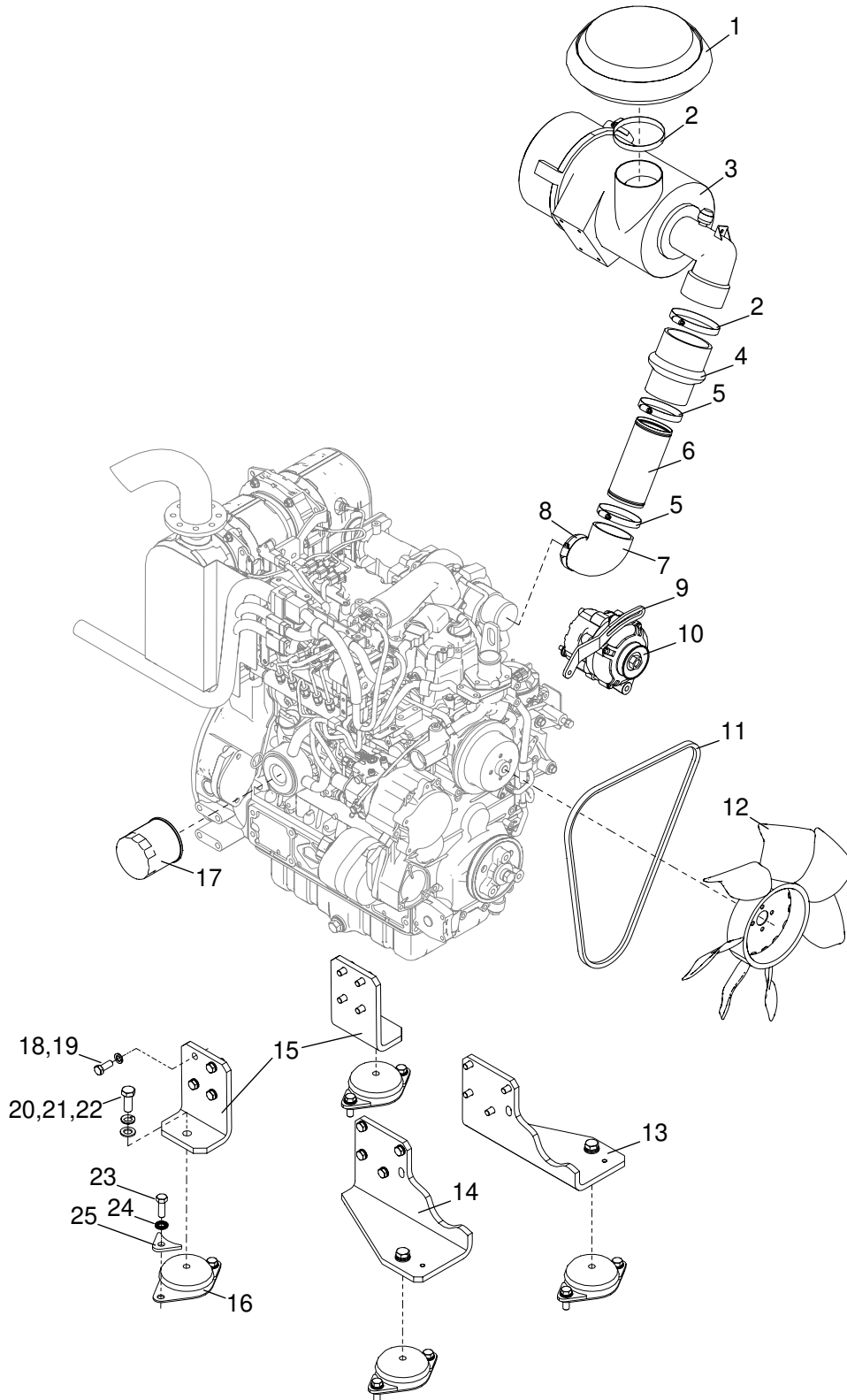

Figure 7-13. Engine Assembly - Intake/Exhaust

Engine Assembly - Intake/Exhaust

Item No	Part Number	Qty	Description	Remarks
REF	1016478	1	Kubota Engine, T4F, 74HP	
1	1002917-29	1	Air Inlet Hood, 3.75"	
2	1016249-30	2	Hose Clamp, 4.00"	
3	1010255	1	Air Breather Assembly	
REF	1009253-17	1	Primary Air Filter	
REF	38385-02	1	Secondary Air Filter	
4	1002676-23	1	Intake Reducer, 3.00" - 3.50"	
5	1016249-29	2	Hose Clamp, 3.50"	
6	1013710-02	1	Lower Intake Pipe	
7	1009384-02	1	Reducing Elbow	
8	1016249-28	1	Hose Clamp, 2.86"	
9	1009253-31	1	Alternator Bracket	
10	1009253-21	1	Alternator	
11	1009253-20	1	Fan Belt	
12	1016478-01	1	Radiator Fan	
13	986537-17	1	Front Engine Mount - Left	
14	986537-16	1	Front Engine Mount - Right	
15	988673-14	2	Rear Engine Mount	
16	986537-14	4	Engine Isolator	
17	986537-03	1	Oil Filter	
18	100-M12-1.75-30-8.8F	16	CSHH, M12x1.75 x 30mm, C8.8, FT	
19	300-M12	16	Washer, Lock, M12	
20	100-M16-2-40-8.8F	4	CSHH, M16x2 x 40mm, C8.8, FT	
21	302-M16	4	Washer, Lock, M16	
22	300-M16	4	Washer, Flat, SAE, M16	
23	100-8-13-24-8	8	CSHH, 1/2-13 x 1.50, GR8	
24	986810	8	Washer, Lock, .500 Nord Wedge	
25	1017061	8	Generator Tray	

Illustrated Parts List

ENGINE ASSEMBLY - COMPONENTS (1 OF 2)

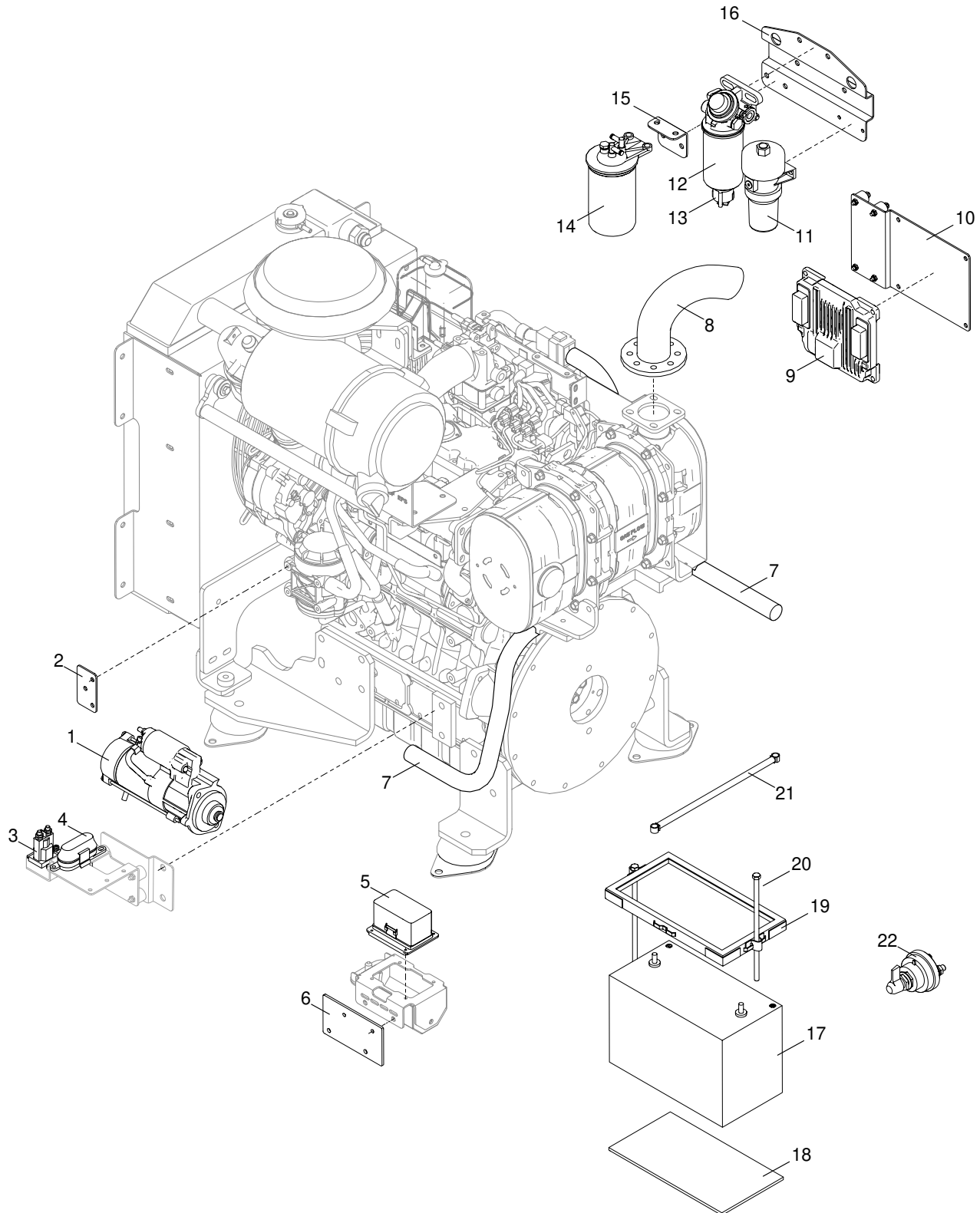

Figure 7-14. Engine Assembly - Components (1 of 2)

Engine Assembly - Components (1 of 2)

Item No	Part Number	Qty	Description	Remarks
REF	1016478	1	Kubota Engine, T4F, 74HP	
1	1001166-03	1	Starter	
2	1009253-29	1	Harness Bracket	
3	985751	1	12V DC Relay, SPST, 100A HD	
4	1009253-27	1	Fuse Holder	
5	1011049-39	1	Fuse Block	See Figure 7-10
6	1016713	1	Fuse Block Bracket Plate	
7	1011799-24	1	Intermediate Engine Harness	
8	1011364	1	Tail Pipe	
9	1009253-24	1	ECU	
10	1009253-01	1	ECU Mounting Bracket	
11	1010471	1	Fuel Pump with Filter	
12	1009253-19	1	Fuel/Water Separator Filter	
13	1009253-36	1	Fuel Sender	
14	1009253-18	1	Fuel Filter	
15	1016249-08	1	Fuel Filter Mount	
16	1016249-07	1	Fuel Pump/Filters Mount	
17	Purchase Locally	1	12V Battery, 1150 CCA, Group# 31	
18	720130	1	Battery Tray Pad	
19	72313	1	Battery Hold Down	
20	100-6-16-160-5	2	CSHH, 3/8-16 x 10.00, GR5	
21	986803	1	Negative Battery Cable	
22	1009253-34	1	Battery Disconnect Switch	

Illustrated Parts List

ENGINE ASSEMBLY - COMPONENTS (2 OF 2)

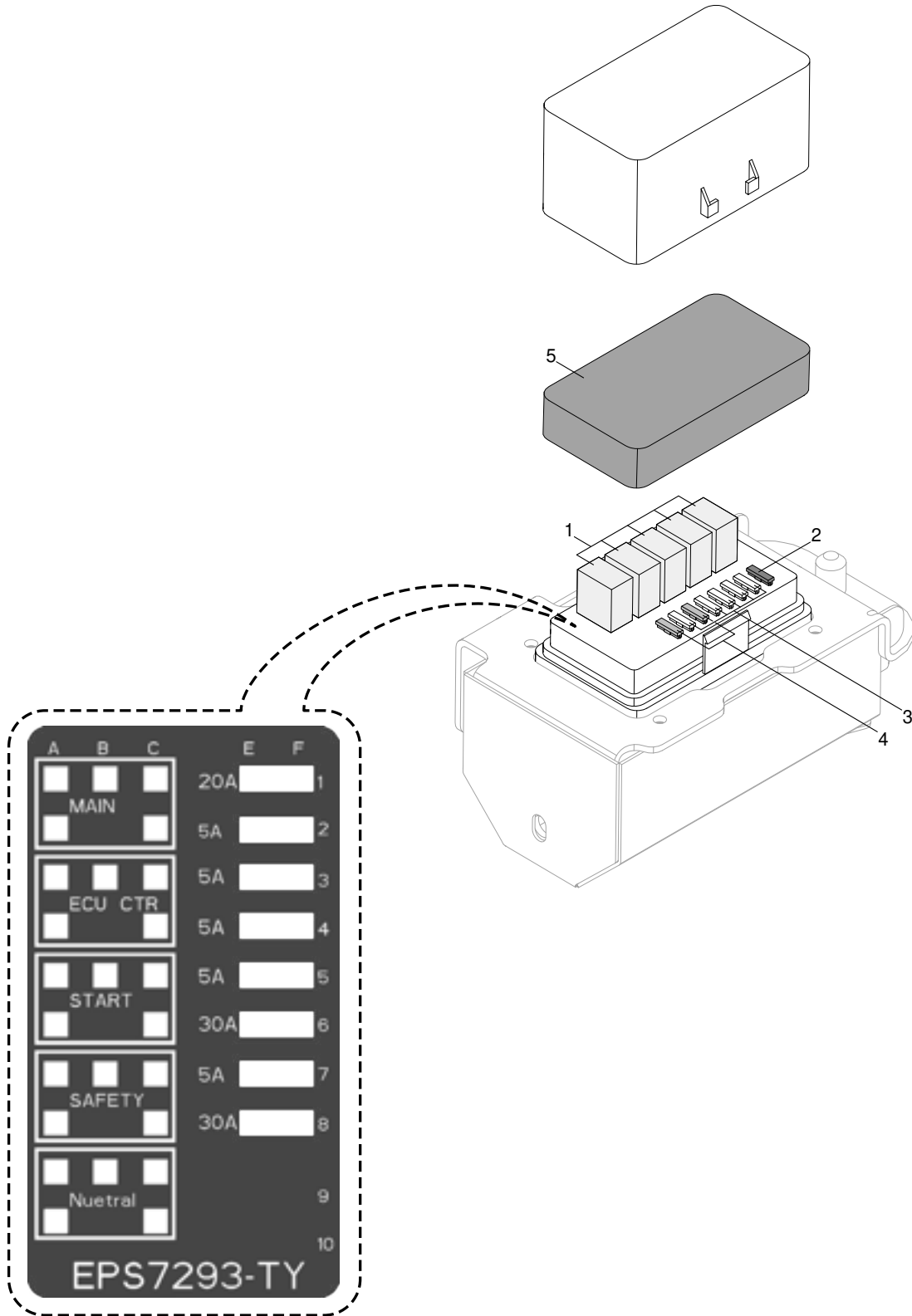

Figure 7-15. Engine Assembly - Components (2 of 2)

Engine Assembly - Components (2 of 2)

Item No	Part Number	Qty	Description	Remarks
REF	1016478	1	Kubota Engine, T4F, 74HP	
1	1009253-41	5	Power Block Relay	
2	1017776-20	1	ATM Blade Fuse, 20A	
3	1017776-05	5	ATM Blade Fuse, 5A	
4	1017776-30	2	ATM Blade Fuse, 30A	
5	1009253-45	1	Fuse Box Foam Rubber	

Illustrated Parts List

ENGINE ASSEMBLY - PUMPS

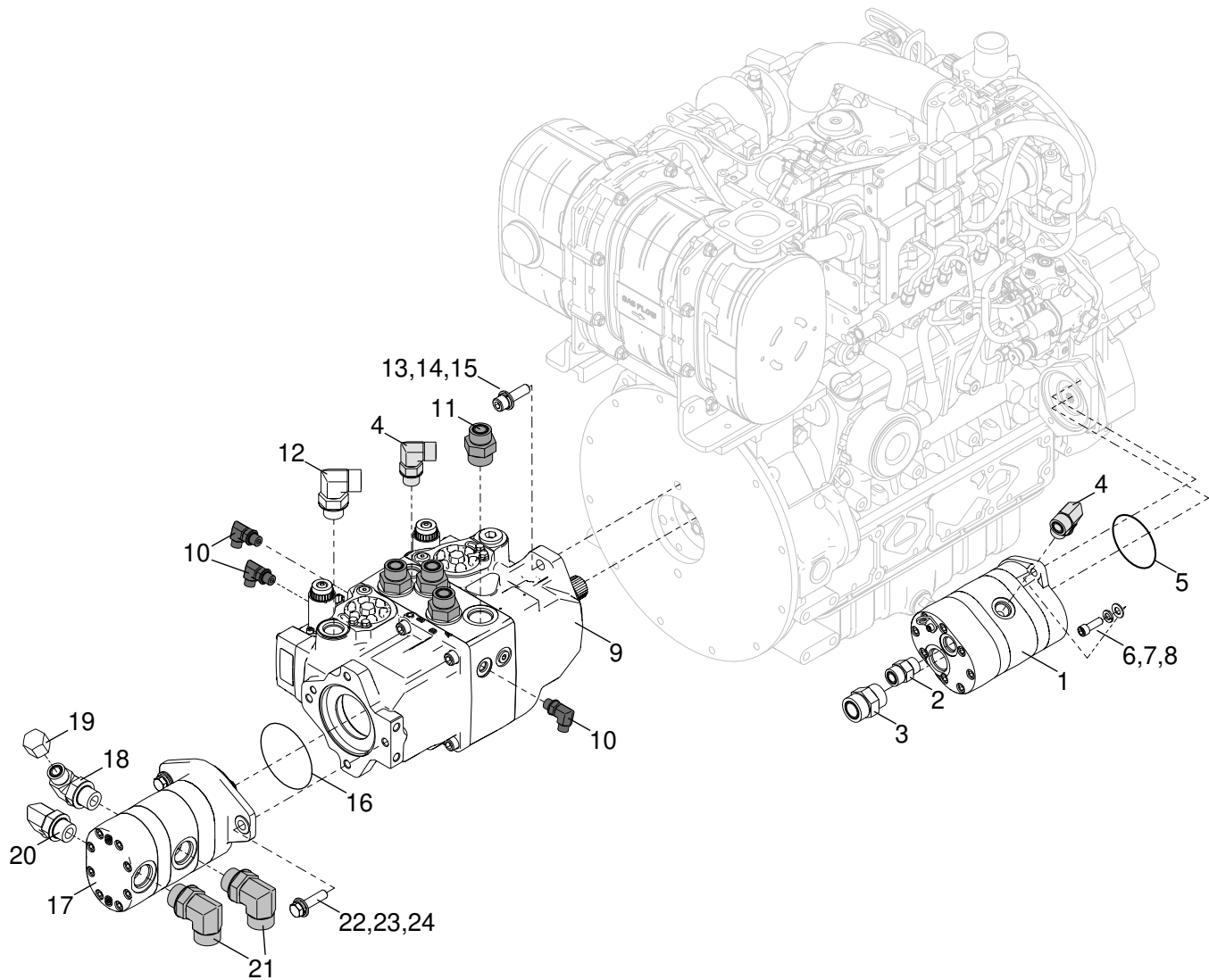

Figure 7-16. Engine Assembly - Pumps

Engine Assembly - Pumps

Item No	Part Number	Qty	Description	Remarks
1	1017733	1	Hydraulic Pump, Tandem, 22.5 CC/19 CC, 9T	
2	FS6400-10-10-O	1	Straight Adapter, -10 ORFS/-10 O-Ring	
3	FS6400-16-16-O	1	Straight Adapter, -16 ORFS/-16 O-Ring	
4	FS6801-10-10-NOW-FG	2	Elbow Adapter, 90°, -10 ORFS/-10 O-Ring	
6	36808	1	O-Ring, 3.237 ID x .103, SAE 152	
6	102-M10-1.5-30-10.9F	2	CSSH, M10x1.25 x 30mm, C10.9, FT	
7	302-M10	2	Washer, Lock, M10	
8	300-M10	2	Washer, Flat, SAE, M10	
9	1009527	1	Tandem Hydraulic Pump, H1 w/EDC, w/o Charge	
10	FS6801-4-6-NWO-FG	3	Elbow Adapter, 90°, -4 ORFS/-6 O-Ring	
11	FS6400-12-16-O	1	Straight Adapter, -12 ORFS/-16 O-Ring	
12	FS6801-12-12-NWO-FG	1	Elbow Adapter, 90°, -12 ORFS/-12 O-Ring	
13	100-8-13-28-8	2	CSSH, 1/2-13 x 1.75, GR8	
14	302-8	2	Washer, Lock, 1/2	
15	300-8	2	Washer, Flat, SAE, 1/2	
16	12757410	1	O-Ring, FKM/Viton, 75D, 3.737 ID x .103	
17	1016845	1	Tandem Hydraulic Pump, 31.8 CC/25.1 CC, 13T, B	
18	FS6803-10-10-12-NWO-FG	1	Branch Tee Adapter, -10 ORFS/ -10 ORFS/ -12 O-Ring	
19	FS304-C-10	1	Cap Adapter, -10 ORFS	
20	FS6801-10-12-NWO-FG	1	Elbow Adapter, 90°, -10 ORFS/-12 O-Ring	
21	FS6801-16-16-NWO-FG	2	Elbow Adapter, 90°, -16 ORFS/-16 O-Ring	
22	100-M12-1.75-35-10.9F	2	CSHH, M12x1.75 x 40mm, C10.9, FT	
23	302-M12	2	Washer, Lock, M12	
24	300-M12	2	Washer, Flat, SAE, M12	

Illustrated Parts List

HOODS AND COVERS - LEFT

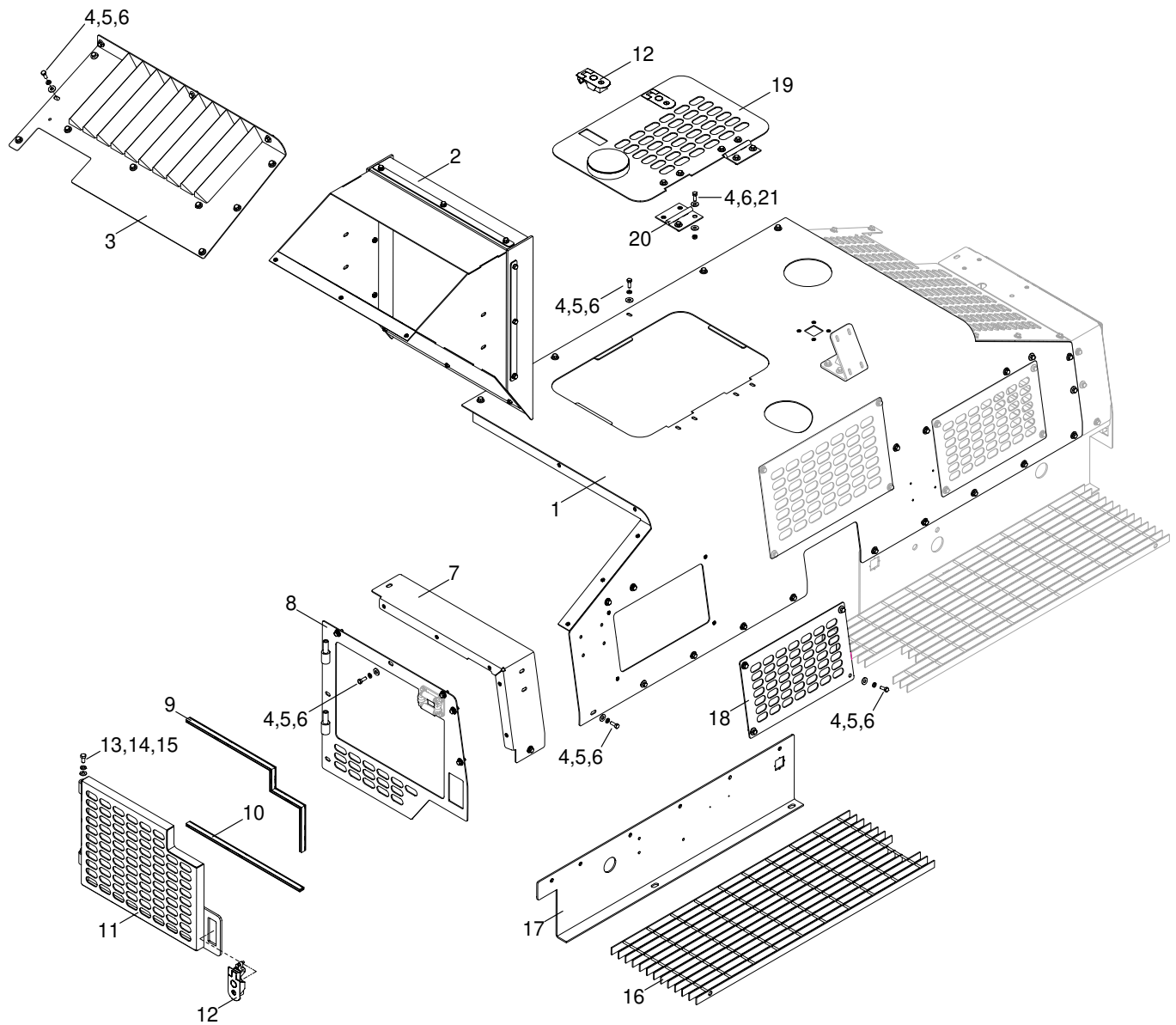

Figure 7-17. Hoods and Covers - Left

Hoods and Covers - Left

Item No	Part Number	Qty	Description	Remarks
1	1016421	1	Center Hood Weldment	
2	1016486	1	Radiator Deflector Assembly	
3	1016419	1	Engine Cover & Deflectors Weldment	
4	100-5-18-14-5F	A/R	CSHH, 5/16-18 x .875, GR5, FT	
5	302-5	A/R	Washer, Lock, 5/16	
6	301-5	A/R	Washer, Flat, USS, 5/16	
7	1016542	1	Engine Cover Weldment - Left	
REF	1016468	1	Side Access Door Assembly - Left	Includes Items 8-12
8	1016442	1	Access Door Mount - Left	
9	1016435	1	Edge Trim - Upper	
10	1016438	1	Edge Trim - Lower	
11	1016467	1	Access Door - Left	
12	980460	3	Lever Latch	
REF	35560	A/R	Replacement Key	
13	100-6-16-12-5F	2	CSHH, 3/8-16 x .75, GR5, FT	
14	302-6	2	Washer, Lock, 3/8	
15	300-6	2	Washer, Flat, SAE, 3/8	
16	1015504	1	Floor Board Grating - Left	
17	1016550	1	Driver Side Toeboard	
18	1016417	1	Rear Side Access Cover	
19	1016548	1	Top Access Door	
20	980316	2	Hinge	
21	204-5-18-5	8	Nut, Lock, Stover, 5/16-18, GR5	

Illustrated Parts List

HOODS AND COVERS - RIGHT

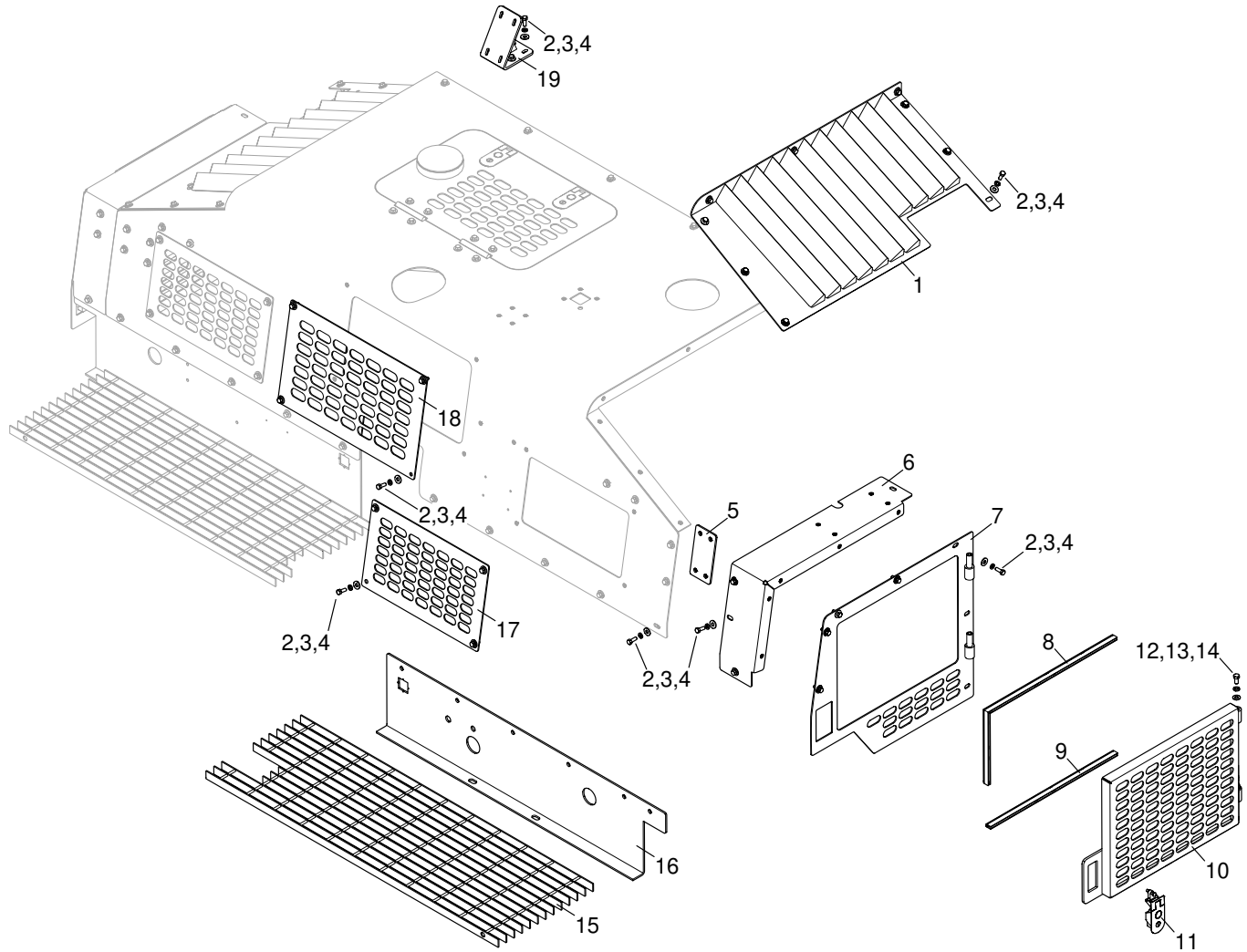

Figure 7-18. Hoods and Covers - Right

Hoods and Covers - Right

Item No	Part Number	Qty	Description	Remarks
1	1019430	1	Oil Cooler Deflector	
2	100-5-18-14-5F	A/R	CSHH, 5/16-18 x .875, GR5, FT	
3	302-5	A/R	Washer, Lock, 5/16	
4	301-5	A/R	Washer, Flat, USS, 5/16	
5	1016404	1	Cover Connector Weldment	
6	1016544	1	Engine Cover Weldment - Right	
REF	1016416	1	Side Access Door Assembly - Right	Includes Items 7-11
7	1016434	1	Access Door Mount Weldment - Right	
8	1016435	1	Edge Trim - Upper	
9	1016438	1	Edge Trim - Lower	
10	1016431	1	Access Door Weldment - Right	
11	980460	1	Lever Latch	
REF	35560	A/R	Replacement Key	
12	100-6-16-12-5F	2	CSHH, 3/8-16 x .75, GR5, FT	
13	302-6	2	Washer, Lock, 3/8	
14	300-6	2	Washer, Flat, SAE, 3/8	
15	1015503	1	Floor Board Grating - Right	
16	1016551	1	Passenger Side Toeboard Weldment	
17	1016417	1	Rear Side Access Cover	
18	1016425	1	Top Access Hole Cover	
19	1011395	1	Air Breather Mount Weldment	

Illustrated Parts List

SPRAY DOWN

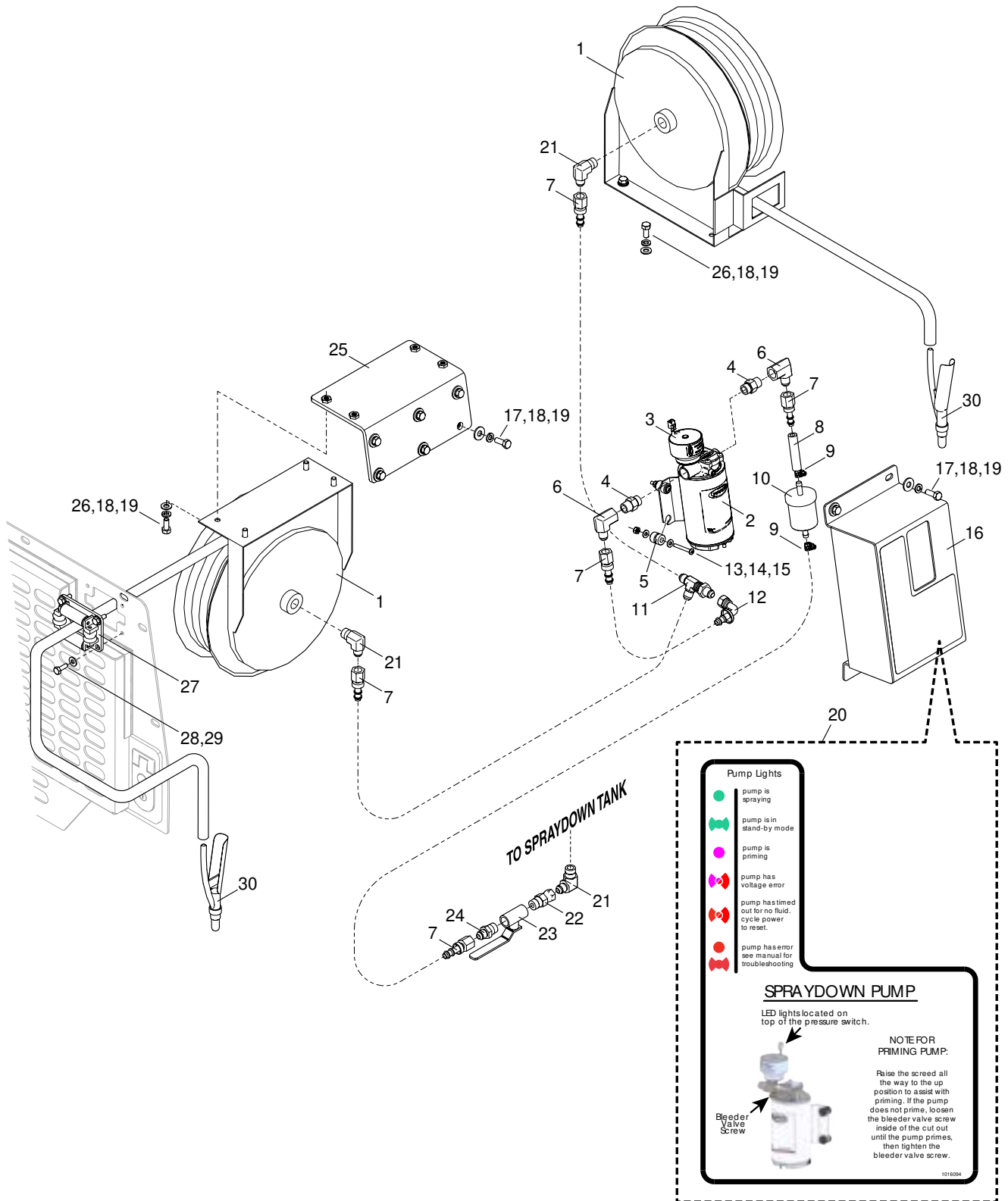

Figure 7-19. Spray Down

Illustrated Parts List

Spray Down

Item No	Part Number	Qty	Description	Remarks
REF	1017031	1	Spray Down System Assembly	Includes All Except As Noted
1	920200	2	Spray Down Reel w/Hose	
REF	1015438	1	Spray Down Pump w/Pressure Switch	Includes Items 2 - 5
2	1015438-01	1	Spray Down Pump Body	
3	1015438-02	1	Pressure Sensor	
4	1015089-04	2	Straight Adapter, -6 BSPP / -6 NPT	
5	1015089-05	4	Pump Isolator	
6	2502-6-6	2	Elbow Adapter, 90°, -6 JIC / -6 NPTF	
7	5LOC-6RFJX	5	Push Lok Fitting, -5 LOC / -6 RFJX	
8	71812	0.21	Push On Hose, .05,	2.50" Long
9	33277	2	Hose Clamp, #04 (.22 - .62)	
10	986537-31	1	Inline Filter	
11	2704-6-6-6-LN	1	Run Tee Bulkhead Adapter, -6 JIC / -6 JIC / -6	
12	33982-6-6	1	Push Lok Fitting, 90° Short, -6 FJX / -6 PL	Not Included
13	122-#10-32-20F	4	PHMS, Cross, #10-32 x 1.50, FT	
14	300-#10	8	Washer, Flat, SAE, #10	
15	205-#10-32-5	4	Nut, Lock, Nylon, #10-32, GR5	
16	1016580	1	Spray Down Pump Weldment	Not Included
17	100-5-18-14-5F	9	CSHH, 5/16 x .875, GR5, FT	Not Included
18	302-5	17	Washer, Lock, 5/16	Not Included
19	300-5	17	Washer, Flat, SAE, 5/16	Not Included
20	1016094	1	Decal - Spray Down Pump Operation	Not Included
21	2501-6-6	3	Elbow Adapter, 90°, -6 JIC / -6 NPT	
22	6505-6-6	1	Male Pipe Dwivel Adapter, -6 NPTF / -6 JIC	
23	480160	1	Ball Valve, 3/8	
24	2404-6-6	1	Connector Adapter, -6 JIC / -6 NPTF	
25	1016541	1	Hose Reel Mount - Left	Not Included
26	100-5-18-12-5F	8	CSHH, 5/16 x .75, GR5, FT	
27	1016409	1	Roller Hose Guide Assembly	Not Included
28	100-4-20-12-5F	4	CSHH, 1/4-20 x .75, GR5, FT	Not Included
29	300-4	4	Washer, Flat, SAE, 1/4	Not Included
30	920220	2	Wash Down Handle & Nozzle	
REF	901210A	2	Wash Down Nozzle	Included With Item 30

7

Illustrated Parts List

TOW POINT ASSEMBLY

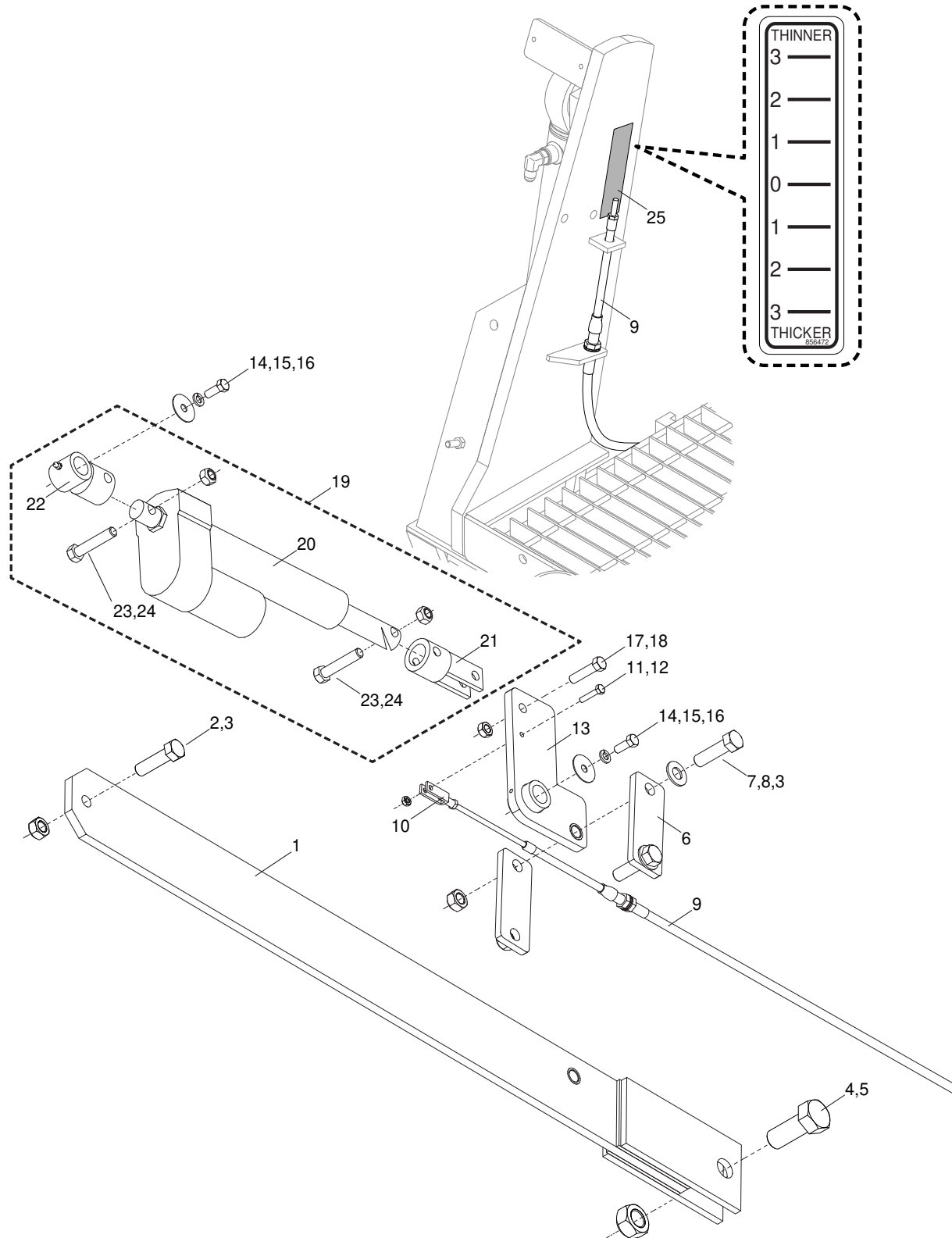

Figure 7-20. Tow Point Assembly

Tow Point Assembly

Item No	Part Number	Qty	Description	Remarks
1	851206SRV	2	Screed Front Pull Arm	(1) Left, (1) Right
2	100-10-11-40-5	2	CSHH, 5/8-11 x 2.50, GR5	(1) Left, (1) Right
3	204-10-11-5	6	Nut, Lock, Stover, 5/8-11, GR5	(3) Left, (3) Right
4	100-16-8-40-5	2	CSHH, 1-8 x 2.50, GR5	(1) Left, (1) Right
5	204-16-8-5	2	Nut, Lock, Stover, 1-8, GR5	(1) Left, (1) Right
6	851210	4	Screed Pull Arm Pivot Ears	(2) Left, (2) Right
7	100-10-11-36-5	4	CSHH, 5/8-11 x 2.25, GR5	(2) Left, (2) Right
8	300-10	4	Washer, Flat, SAE, 5/8	(2) Left, (2) Right
9	851520	2	Push/Pull Cable, 90" x 5" Stroke	(1) Left, (1) Right
10	350050	2	Clevis, 1/4-28	(1) Left, (1) Right
11	100-4-20-20-5	2	CSHH, 1/4-20 x 1.25, GR5	(1) Left, (1) Right
12	204-4-20-5	2	Nut, Lock, Stover, 1/4-20, GR5	(1) Left, (1) Right
13	851209	2	Screed Pull Arm Pivot Mount	(1) Left, (1) Right
14	100-6-16-16-5F	4	CSHH, 3/8-16 x 1.00, GR5, FT	(2) Left, (2) Right
15	302-6	4	Washer, Lock, 3/8	(2) Left, (2) Right
16	308-6-24	4	Washer, Flat, Fender, 3/8 x 1.50	(2) Left, (2) Right
17	100-7-20-28-5	2	CSHH, 7/16-20 x 1.75, GR5	(1) Left, (1) Right
18	204-7-20-5	2	Nut, Lock, Stover, 7/16-20, GR5	(1) Left, (1) Right
19	853853L	1	Electric Screw Assembly - Left	Includes Items 20 - 24
REF	853853R	1	Electric Screw Assembly - Right	Not Shown, Includes Items 20 - 24
20	851518	2	Linear Actuator, 6.00, 12V	(1) Per Assembly
21	851211	2	Electric Screw Rod End Clevis	(1) Per Assembly
22	851212	2	Linear Actuator Rod Weldment	(1) Per Assembly
23	100-8-13-40-5	4	CSHH, 1/2-13 x 2.50, GR5	(2) Left, (2) Right
24	204-8-13-5	4	Nut, Lock, Stover, 1/2-13, GR5	(2) Left, (2) Right
25	856472	2	Decal - Thicker/Thinner	(1) Left, (1) Right
OPT		1	Option - Hydraulic Tow Point	Not Shown
REF	987725	1	Hydraulic Cylinder, 2.00 x 6.00	Not Shown
REF	1016687	1	Tow Point Manifold w/Flow Control	Not Shown
REF	1018637	1	Hydraulic Tow Point Hose Kit	Not Shown

Hydraulic Manifold - Upper

Item No	Part Number	Qty	Description	Remarks
GRP	1019164		Upper Manifold Assembly w/ ORFS Adapters	Includes All Items
REF	1011728	1	Hydraulic Manifold, 9-Station, 7 Valve	Includes Items 1-9
1	983643-13	A/R	Upper Manifold, 9-Station	
2	983643-05	A/R	Dual Pilot Operated Check Valve	
3	983643-09	A/R	CV08 Check Valve	
4	1011728-01	A/R	Directional Solenoid Valve	
5	1011728-02	A/R	12V DC Coil w/Deutsch Connector	
6	983643-08	A/R	CV04 Check Valve	
7	983643-10	A/R	FD10 Flow Divider	
8	983643-07	A/R	RV08 Relief Valve	
9	983643-06	A/R	Piloted Logic Element Valve	
10	FS6801-6-6-NWO-FG	1	Elbow Adapter, 90°, -6 ORFS/-6 O-Ring	
11	6409-6-O	1	Plug Adapter, Hex Socket, O-Ring, -6	
12	FS6400-6-6-O	10	Straight Adapter, -6 ORFS/-6 O-Ring	
13	FS6400-6-6-O X 060	3	Straight Adapter, -6 ORFS/-6 O-Ring w/.060 Orifice	
14	FS6801-12-10-NWO-FG	1	Elbow Adapter, 90°, -12 ORFS/ -10 O-Ring	
15	FS6801-10-10-NOW-FG	1	Elbow Adapter, 90°, -10 ORFS/-10 O-Ring	
16	1019632	A/R	High Pressure O-Ring Kit	Not Shown

Illustrated Parts List

HYDRAULIC MANIFOLD - LOWER

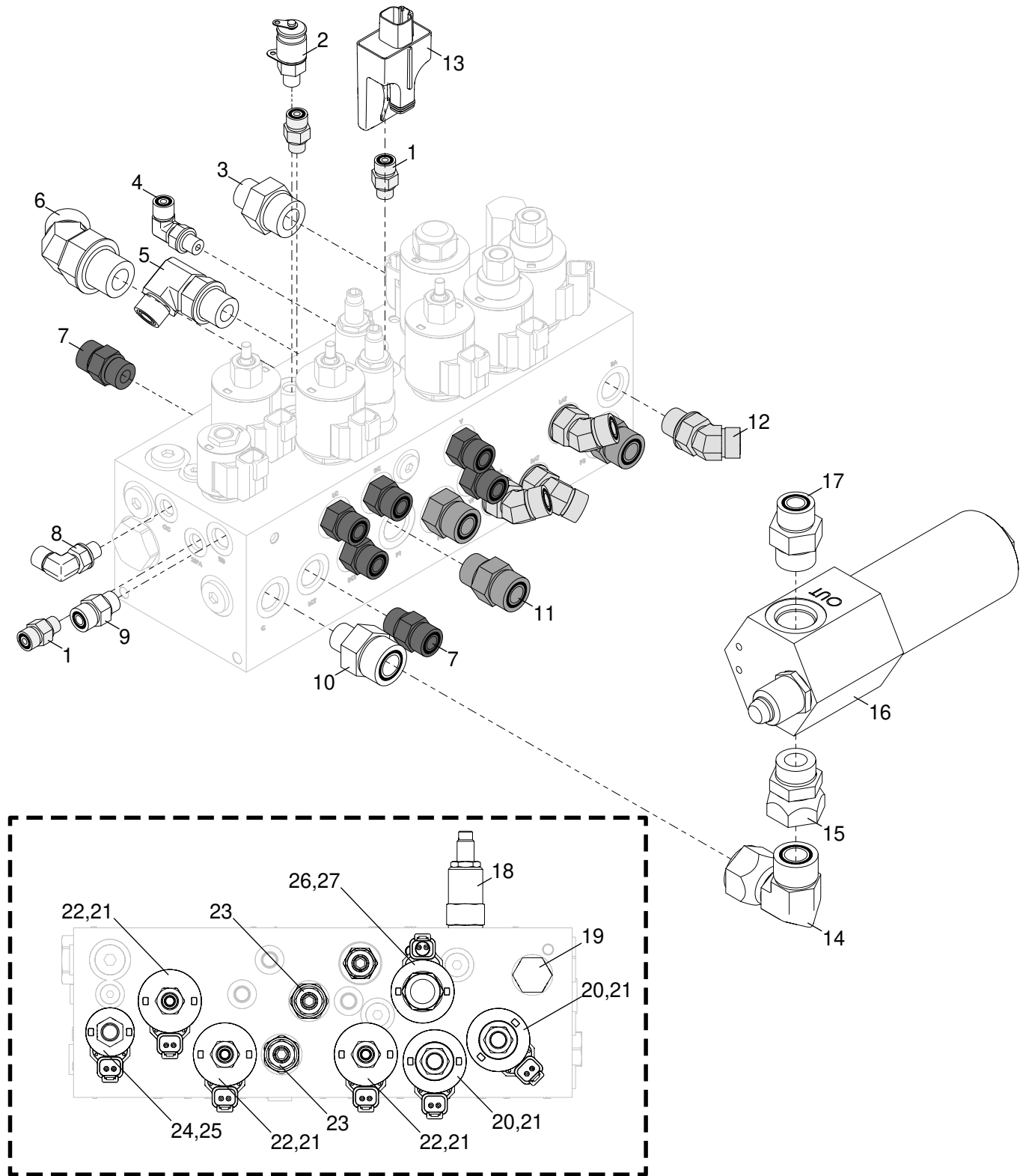

Figure 7-22. Hydraulic Manifold - Lower

Hydraulic Manifold - Lower

Item No	Part Number	Qty	Description	Remarks
GRP	1019159		Lower Manifold Assembly w/ ORFS Adapters	Includes Items 1-13
1	FS6400-04-04-O	3	Straight Adapter, -4 ORFS/-4 O-Ring	
2	DP6400-04-O	1	Test Point Coupling, -4 O-Ring	
3	FS6400-08-12-O	1	Straight Adapter, -8 ORFS/-12 O-Ring	
4	FS6801-04-04-NWO-FG	1	Elbow Adapter, 90°, -4 ORFS/-4 O-Ring	
5	FS6801-08-10-NWO-FG	1	Elbow Adapter, 90°, -8 ORFS/-10 O-Ring	
6	FS6802-12-12-NWO-FG	1	Elbow Adapter, 45°, -12 ORFS/-12 O-Ring	
7	FS6400-08-08-O	7	Straight Adapter, -8 ORFS/-8 O-Ring	
8	FS6801-04-04-NWO-FG X 078	1	Elbow Adapter, 90°, -4 ORFS/-4 O-Ring, .078 Orifice	
9	FS6400-06-06-O	1	Straight Adapter, -6 ORFS/-6 O-Ring	
10	FS6400-12-08-O	2	Straight Adapter, -12 ORFS/-8 O-Ring	
11	FS6400-10-10-O	3	Straight Adapter, -10 ORFS/-10 O-Ring	
12	FS6802-08-08-NWO-FG	4	Elbow Adapter, 45°, -8 ORFS/-8 O-Ring	
13	1018639	1	Valve Driver, EGDR-0101A, 10 kW Gen Controller	
REF	1019175	1	Hydraulic Filter Assembly w/ORFS Adapters, 3000 PSI, 25 GPM	Includes Items 14-17
14	FS6500-12-12-FG	1	Elbow Adapter, 90°, Swivel, -12 ORFS/-12 ORFS	
15	FS6540-12-12-O	1	Swivel Straight Adapter, -12 ORFS/-12 O-Ring	
16	984594	1	Hydraulic Filter Assembly	
REF	984594-01	1	Hydraulic Filter Element	Not Shown
17	FS6400-10-12-O	1	Straight Adapter, -10 ORFS/-12 O-Ring	
REF	1017982	1	Hydraulic Manifold, Motor Functions w/10 kW Gen Controller	Includes Items 17-26
18	1015402-04	1	Cartridge Relief Valve	
19	1017450-03	1	EP10-S35T-0-N-230	
20	1016083-02	2	Valve, SP12-21AP-0-N-0-E	
21	1002070-01	5	Coil, 4303712	
22	983644-02	3	Valve, SV12-23P-0-N-00	
23	1015402-03	2	Relief Valve, RV50-26A-0-P-50/27	
24	1006953-09	1	Valve, SV08-30-0-N-00	
25	1006953-15	1	Coil, 4303612	
26	1017450-02	1	Valve, PV70-33C-0-N-00	
27	1000825-01	1	Coil, 4303212	
REF	1016536	1	Lower Manifold Harness	Not Shown

Illustrated Parts List

HYDRAULIC OIL COOLER

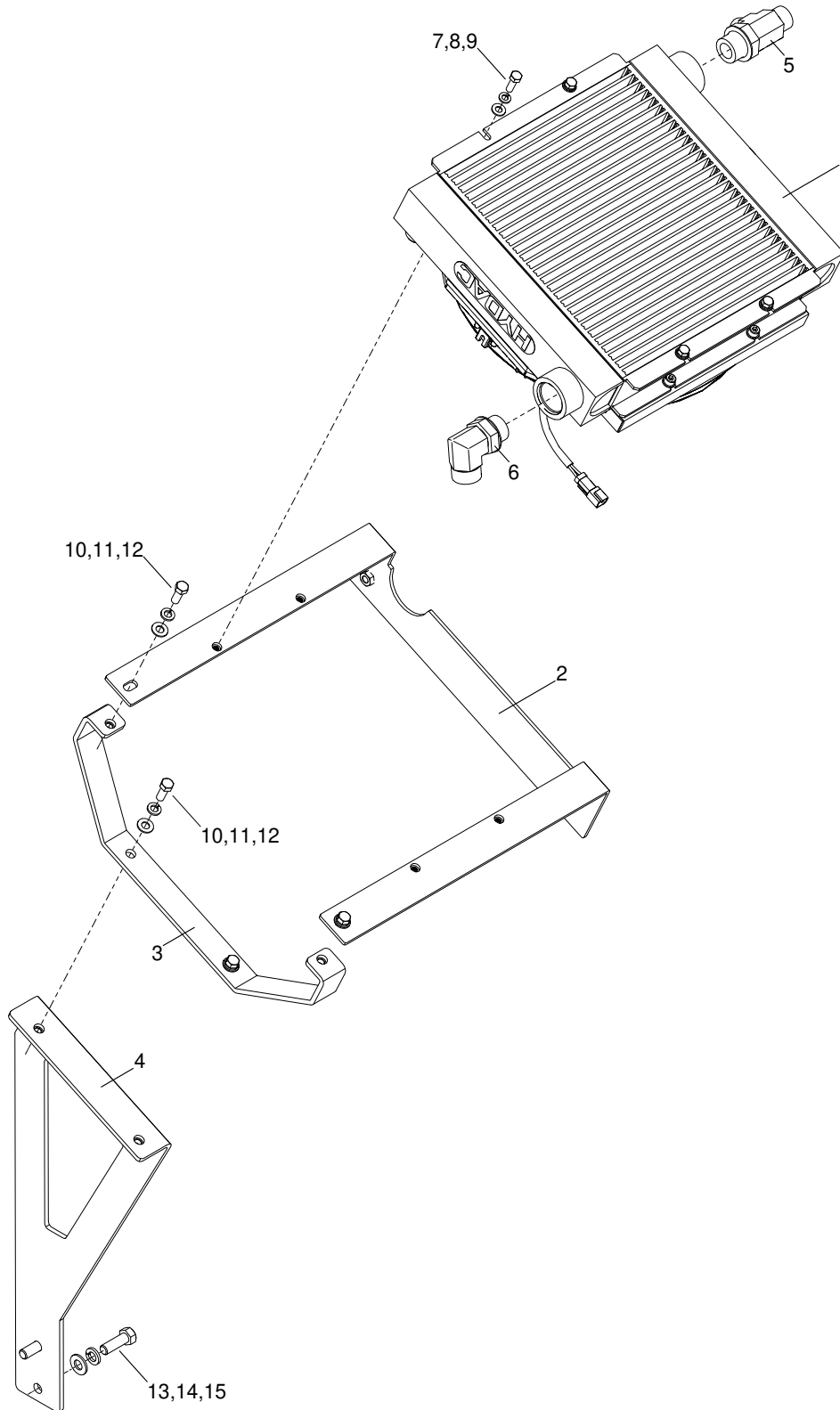

Figure 7-23. Hydraulic Oil Cooler

Hydraulic Oil Cooler

Item No	Part Number	Qty	Description	Remarks
1	1019123	1	Auxiliary Oil Cooler w/Fan	
REF	1018378-01	1	Oil Cooler Fan, Brushless	Included with Item 1
REF	1019123-01	1	Oil Cooler Heat Exchanger	Included with Item 1
REF	1018378-03	1	Oil Cooler Temperature Switch	Included with Item 1
2	1016567	1	Cooler Mount Weldment - Top	
3	1016565	1	Oil Cooler Mounting Bracket	
4	1016708	1	Cooler Mounting Brace	
5	FS6804-12-16-12-NWO-FG	1	Run Tee Adapter, -12 ORFS/ -16 O-Ring/ -12 ORFS	
6	FS6801-16-16-NWO-FG	1	Elbow Adapter, 90°, -16 ORFS/ -16 O-Ring	
7	100-5-18-16-5F	4	CSHH, 5/16-18 x 1.00, GR5, FT	
8	302-5	4	Washer, Lock, 5/16	
9	300-5	4	Washer, Flat, SAE, 5/16	
10	100-6-16-16-5F	4	CSHH, 3/8-16 x 1.00, GR5, FT	
11	302-6	4	Washer, Lock, 3/8	
12	300-6	4	Washer, Flat, SAE, 3/8	
13	100-8-13-24-5	2	CSHH, 1/2-13 x 1.50, GR5	
14	302-8	2	Washer, Lock, 1/2	
15	300-8	2	Washer, Flat, SAE, 1/2	
REF	1019514	1	Hydraulic Cooler Harness, SPAL Fan	Not Shown
<i>(Previously used fan assembly - confirm w/Customer Service)</i>				
REF	1017837	1	Auxiliary Oil Cooler w/Fan	Not Shown
REF	1016702	1	Hydraulic Cooler Harness	Not Shown

Illustrated Parts List

GENERATOR

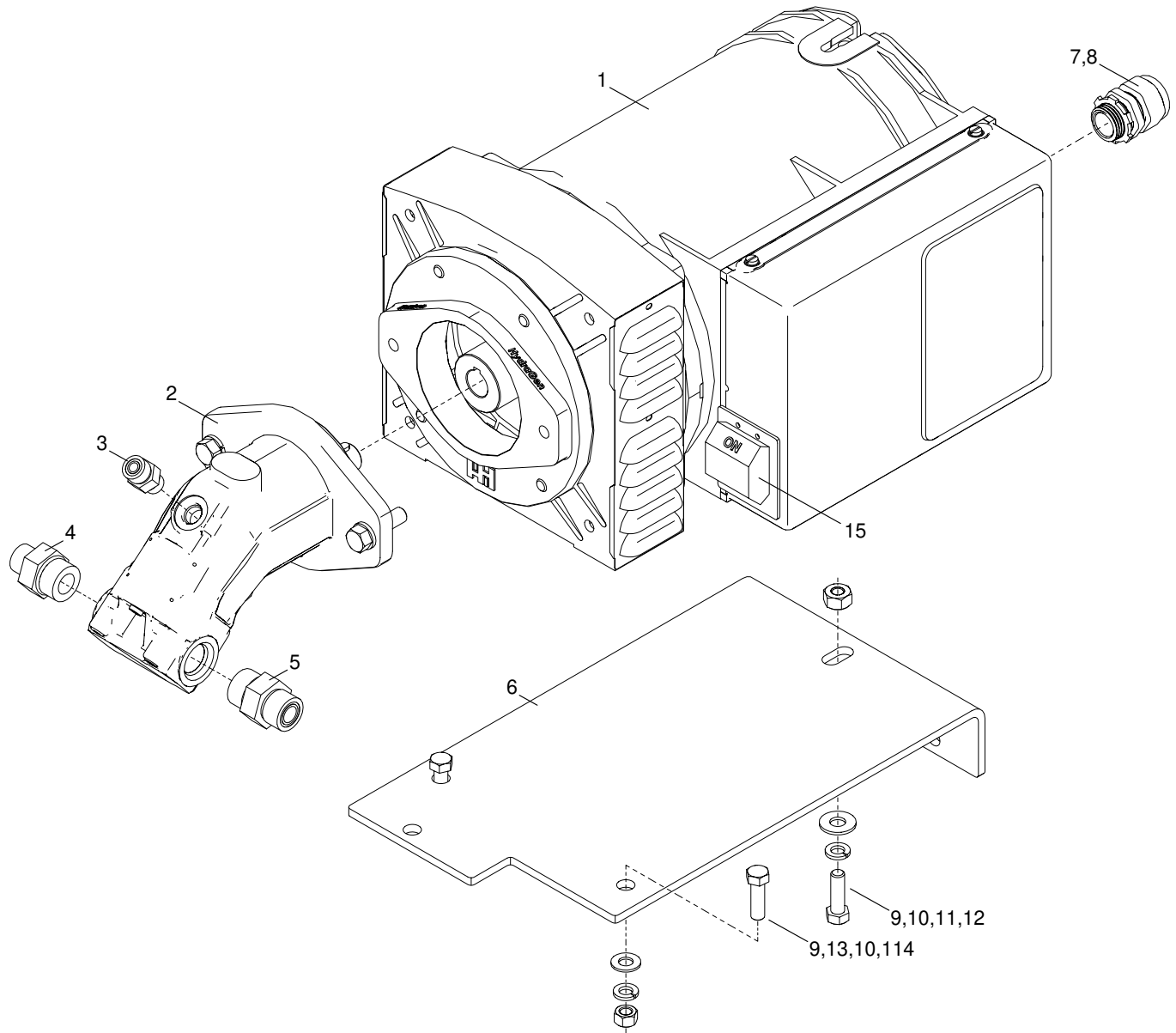

Figure 7-24. Generator

Generator

Item No	Part Number	Qty	Description	Remarks
1	1017009	1	Generator Assembly, 10kW	Includes Item 2
2	1014873-02	1	Bent Axis Piston Motor, 10 CC	
3	FS6400-06-06-O	1	Straight Adapter, -6 ORFS/ -6 O-Ring	
4	FS6400-08-12-O	1	Straight Adapter, -8 ORFS/ -12 O-Ring	
5	FS6400-10-12-O	1	Straight Adapter, -10 ORFS/ -12 O-Ring	
6	1017183	1	Generator Mount	
7	3400DI	1	Water Tight Connector, 3/4 x 3/4 MPT	
8	38965	1	Conduit Lock Nut, 3/4 NPT	
9	100-6-16-20-5	3	CSHH, 3/8-16 x 1.25, GR5	
10	302-6	3	Washer, Lock, 3/8	
11	301-6	1	Washer, Flat, USS, 3/8	
12	201-6-16-5	1	Nut, Hex, Heavy, 3/8-16, GR5	
13	300-6	2	Washer, Flat, SAE, 3/8	
14	200-6-16-5	2	Nut, Hex, 3/8-16, GR5	
15	1017057	1	Circuit Breaker, 50A	
REF	1016724	1	Bulkhead to Generator Harness	Not Shown

Illustrated Parts List

HYDRAULIC CYLINDERS

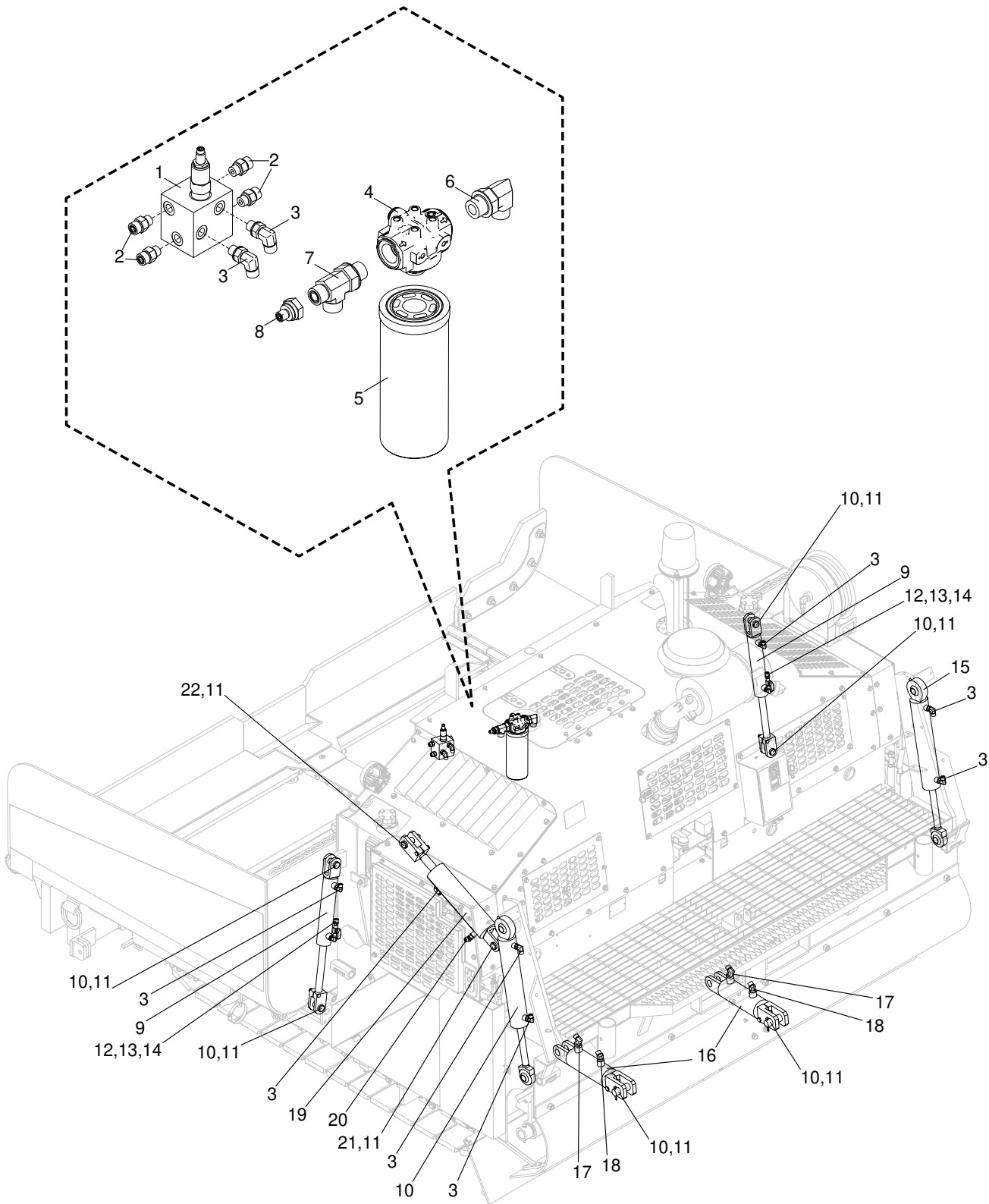

Figure 7-25. Hydraulic Cylinders

Hydraulic Cylinders

Item No	Part Number	Qty	Description	Remarks
REF	1019176	1	Hopper Wing Sequence Manifold Assembly	Includes Items 1-3
1	910122	1	Hopper Wing Sequence Manifold	
2	FS6400-06-06-O	4	Straight Adapter, -6 ORFS/-6 O-Ring	
3	FS6801-06-06-NWO-FG	9	Elbow Adapter, 90°, -6 ORFS/-6 O-Ring	
REF	1018912	1	Charge Filter Assembly	Includes Items 4-8
4	1017402	1	Hydraulic Charge/Return Filter Head	
5	290030	1	Hydraulic Charge Filter Element	
6	FS6801-10-12-NWO-FG	1	Elbow Adapter, 90°, -10 ORFS/-12 O-Ring	
7	FS6804-10-12-10-NWO-FG	1	Run Tee Adapter, -10 ORFS/-12 O-Ring/-10 ORFS	
8	FS2406-10-04	1	Straight Reducer Adapter, -10 FFORX/-4 ORFS	
REF	1019173	2	Hopper Lift Hydraulic Cylinder Assembly	Includes Items 3,9-14
9	610110	2	Hydraulic Cylinder, 2.00 x 8.22 x 1.00 Rod	
10	1011476	10	Clevis Pin, 1.00 x 2.50	
11	80336	10	Cotter Pin, 3/16" x 1-1/2"	
12	6806-6-4 NWO	2	Elbow Adapter, 90°, -6 O-Ring/-4 NPTF	
13	20926564	2	Ball Valve, 1/4	
14	FS2404-06-04	2	Connector Adapter, -6 ORFS/-4 NPTF	
REF	1019251	2	Screed Lift Cylinder Assembly	Includes Items 3,15
15	1014284SRV	2	Screed Lift Cylinder, 2.50 x 12.00 x 1.00	
REF	1019174	2	Auger Cutoff Hydraulic Cylinder Assembly	Includes Items 10,11,16-18
16	910170	2	Hydraulic Cylinder, 2.50 x 4.00 x 1.25 Rod	
17	FS2501-06-06-FG	2	Elbow Adapter, 90°, -6 ORFS/-6 NPTF	
18	FS2503-06-06-FG	2	Elbow Adapter, 45°, -6 ORFS/-6 NPTF	
REF	1019171	1	Conveyor Lift Hydraulic Cylinder Assembly	Includes Items 3,11,19-22
19	1016711	1	Conveyor Lift Cylinder, 3.00 x 9.00	
20	FS6802-06-06-NWO-FG	1	Elbow Adapter, 45°, -6 ORFS/-6 O-Ring	
21	1000285	1	Clevis Pin,ø1.00 x 2.50	
22	1016711-4	1	Clevis Pin	

Illustrated Parts List

DASH ASSEMBLY - CONTROLS

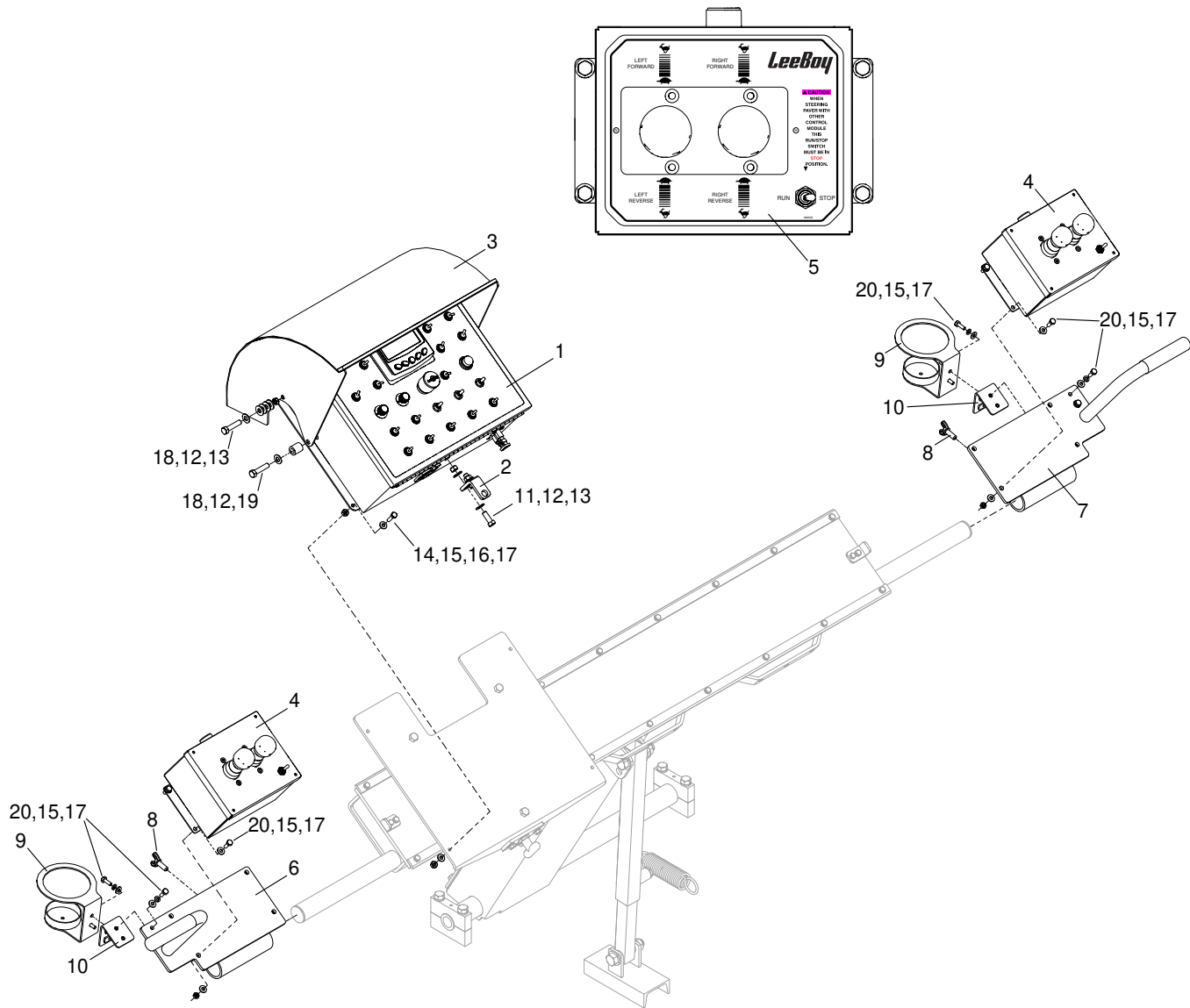

Figure 7-26. Dash Assembly - Controls

Dash Assembly - Controls

Item No	Part Number	Qty	Description	Remarks
1	1016576	1	Control Box Assembly	See Figure 7-28
2	1007337	1	Vandalism Latch Bar	
3	1007339	1	Vandalism Cover Assembly	
4	1016272SRV	2	Dual Joystick Control Box	
REF	851548-04	2	Electronic Steering Cord, 4 Ft.	
5	986539	2	Decal - Dual Joystick Operation	Included With Item 5
6	1017458	1	Dual Joystick Box Weldment - Left	
7	1017466	1	Dual Joystick Box Weldment - Right	
8	120-6-16	4	Wing Screw, Type C, 3/8-16 x 1.00, Cup	Included With Item 6
9	1017632	2	Cupholder Weldment	
10	1017459	2	Cupholder Mount Weldment	
11	100-6-16-16-5F	2	CSHH, 3/8-16 x 1.00, GR5, FT	
12	300-6	16	Washer, Flat, SAE, 3/8	
13	204-6-16-5	4	Nut, Lock, Stover, 3/8-16, GR5	
14	100-4-20-16-5F	4	CSHH, 1/4-20 x 1.00, GR5, FT	
15	300-4	24	Washer, Flat, SAE, 1/4	
16	201-4-20-5	4	Nut, Hex, Heavy, 1/4-20, GR5	
17	204-4-20-5	12	Nut, Lock, Stover, 1/4-20, GR5	
18	100-6-16-26-5	4	CSHH, 3/8-16 x 1.63, GR5	
19	1007338	2	Vandalism Cover Spacer	
20	100-4-20-12-5F	8	CSHH, 1/4-20 x .75, GR5, FT	

Illustrated Parts List

DASH ASSEMBLY - MOUNTING

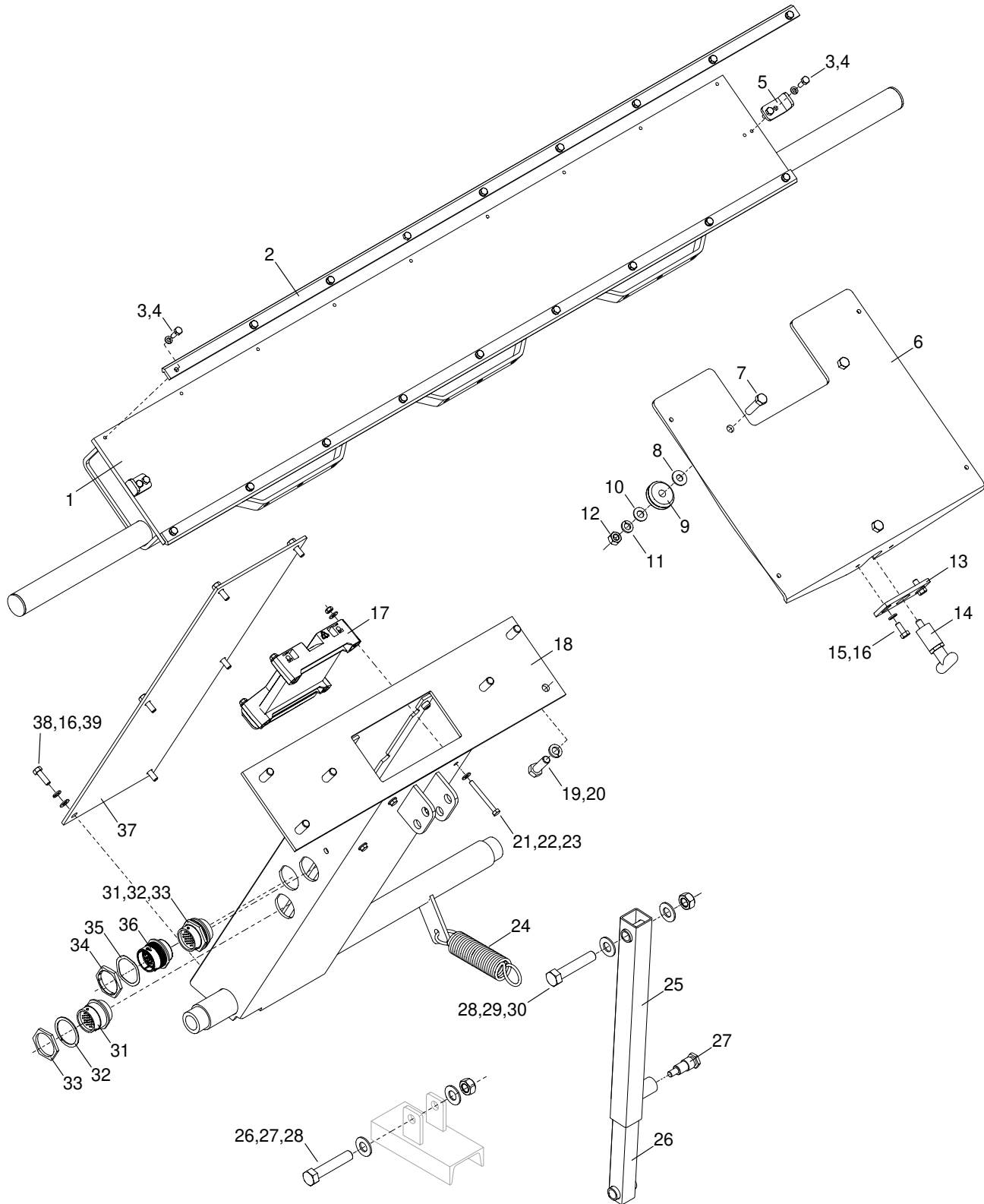

Figure 7-27. Dash Assembly - Mounting

Dash Assembly - Mounting

Item No	Part Number	Qty	Description	Remarks
1	1007239	1	Aluminum Dash Assembly	
2	1007332	2	Dash Slide Rail w/Holes	
3	100-4-20-12-5F	22	CSHH, 1/4-20 x .75, GR5, FT	
4	302-4	22	Washer, Lock, 1/4	
5	1008093	2	Dash Slide Stop Bracket	
6	1007263	1	Enclosure Mounting Plate	
7	100-7-14-28-5	3	CSHH, 7/16-14 x 1.75, GR5	
8	301-7	3	Washer, Flat, USS, 7/16	
9	1007266	3	45mm V-Guide Wheel	
10	300-7	3	Washer, Flat, SAE, 7/16	
11	302-7	3	Washer, Lock, 7/16	
12	200-7-14-5	3	Nut, Hex, 7/16-14, GR5	
13	1007333	1	Dash Pin Lock Plate	
14	1000835	1	Spring Loaded Pull Pin	
15	100-5-18-12-5F	2	CSHH, 5/16-18 x .75, GR5, FT	
16	302-5	8	Washer, Lock, 5/16	
17	1012975SRV	1	Plus 1 Controller, 50 Pin	
18	1016654	1	Dash Support Weldment	
19	100-8-13-24-5	6	CSHH, 1/2-13 x 1.50, GR5	
20	302-8	6	Washer, Lock, 1/2	
21	100-4-20-40-5	4	CSHH, 1/4-20 x 2.50, GR5	
22	300-4	8	Washer, Flat, SAE, 1/4	
23	204-4-20-5	4	Nut, Lock, Stover, 1/4-20, GR5	
24	930029	1	Extension Spring, .177 x 1.50 x 7.00	
25	1017487	1	Outer Tube Pedestal Support Weldment	
26	1017488	1	Inner Tube Pedestal Support Weldment	
27	1017374	1	Column Height Adjustment Pin	
28	100-10-11-52-5	2	CSHH, 5/8-11 x 3.25, GR5	
29	300-10	4	Washer, Flat, SAE, 5/8	
30	204-10-11-5	2	Nut, Lock, Stover, 5/8-11, GR5	
31	981916	2	Receptacle Connector, 31 Pin, HD34-24-31PT	
32	981916-02	2	Lockwasher, 24 Shell Connector	
33	981916-01	2	Nut, 24 Shell Connector	
34	1011854	1	Nut, Connector, HDP20 Series	
35	1011855	1	Washer, Connector, HDP20 Series	
36	1014909	1	Receptacle, 19 Pin, HDP20 Series	
37	1007264	1	Dash Channel Cover	
38	100-5-18-16-5	6	CSHH, 5/16-18 x 1.00, GR5	
39	300-5	6	Washer, Flat, SAE, 5/16	

Control Box Assembly-4 Function Screed Control (1 of 2)

Item No	Part Number	Qty	Description	Remarks
GRP	1016576		Control Box Assembly	
1	1016034-01	1	Control Box Enclosure	
2	1016362	1	Decal - Control Box Operation	
3	1016158	1	PV480 Display - V3874 T4F	
4	31985	1	Dash Light - Green	
5	31986	1	Dash Light - Blue	
6	1010500	1	Indicator Light - White	
7	39146-14	1	Ignition Switch	
REF	982008-04	1	Ignition Key	
8	851392	6	Toggle Switch, 3-POS, SPDT, MOM	
9	851391	3	Toggle Switch, 2-POS, SPST	
10	37521	2	Toggle Switch, 3-POS, DPDT, MOM	
11	35049	2	Knob, 1/4" Shaft	
12	1010077	2	Rheostat, 35 Ohm/25 Watt	Not Shown
13	851090613	4	Toggle Switch, 3-POS, SPDT	
14	900030	3	Toggle Switch, Auto Conveyor	
15	1010672	1	E-Stop Switch	
16	982249	1	Push Button Switch	
17	851390	1	Toggle Switch, 3-POS, DPDT	
18	851393	1	Toggle Switch	
19	1015381	1	Connector, 31 Pin, HD34-24-31ST	
20	981916-01	2	Nut, 24 Shell	
21	981916-02	2	Lockwasher, 24 Shell	
22	1014909	1	Receptacle, 19 Pin, HDP20 Series	
23	1011854	1	Connector Nut, HDP20 Series	
24	1011855	1	Connector Lockwasher, HDP20 Series	
25	981916	1	Receptacle, 31 Pin, HD34-24-31ST	
26	1011147	1	12V Cigarette Lighter Receptacle	
27	989179	1	Connector, 3 Pin, Plug	
28	1010657	1	Connector, 3 Pin, Panel Mount, DT04-3P	
29	983211	1	Wedgelock Connector, W3P	
30	982456	3	Deutsch Pin	
31	1016261	1	Decal - Calibration	
32	1016260	1	Toggle Switch Mounting Bracket	
33	36086	3	Relay Mounting Bracket	
34	36085	3	Relay, 12V, SPDT, 40A, 5 Pin	
35	1017351	1	Decal - Relay Diagram	
36	20934592	1	Relay, SPST, 75A	

Illustrated Parts List

CONTROL BOX ASSEMBLY-4 FUNCTION SCREED CTRL (2 OF 2)

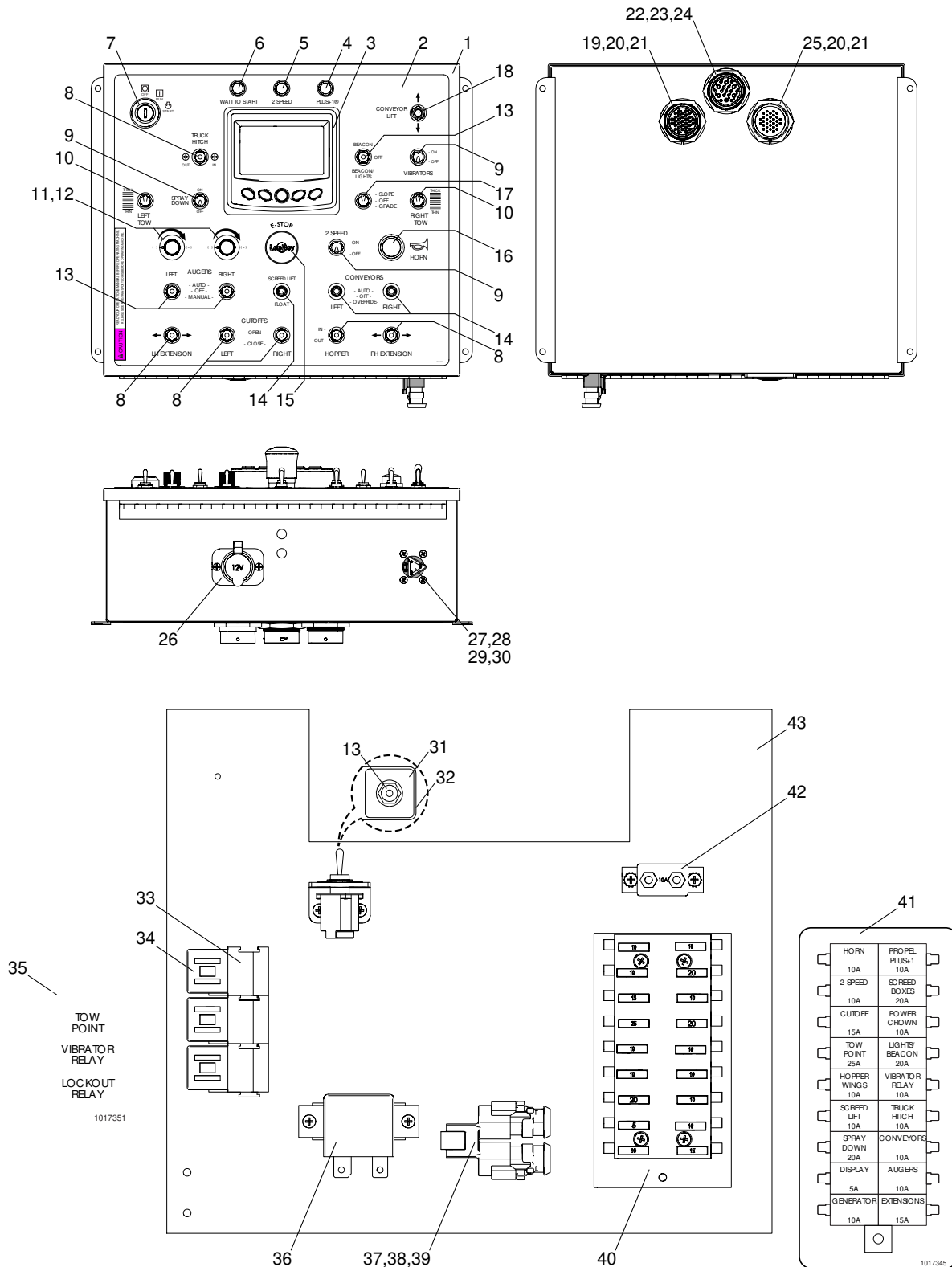

Figure 7-28. Control Box Assembly-4 Function Screed Control (2 of 2)

Control Box Assembly-4 Function Screed Control (2 of 2)

Item No	Part Number	Qty	Description	Remarks
37	989178	1	Connector, 3 Pin, Y Socket	
38	1000649	2	Connector, 3 Pin, DT06-3S-EP11	
39	983210	2	Connector, 3 Pin, Plug	
40	685060	1	Fuse Block, 18 Gang, ATC	
REF	36746	1	Fuse, 5A, ATC	
REF	36340	11	Fuse, 10A, ATC	
REF	36341	2	Fuse, 15A, ATC	
REF	36342	3	Fuse, 20A, ATC	
REF	37303	1	Fuse, 25A, ATC	
41	1017345	1	Decal - Fuse Diagram	
42	986546	1	Circuit Breaker, 10A w/Mount	
43	1007228-03	1	Panel w/Notch	

HARNESS LIST

REF	1016579	1	Main Harness	Not Shown
REF	1016536	1	Lower Manifold Harness	Not Shown
REF	1016263	1	Jumper C4 Dash To Pedestal Harness	Not Shown
REF	1016264	1	Jumper C3 Dash To Pedestal Harness	Not Shown
REF	1016702	1	Hydraulic Cooler Harness	Not Shown
REF	1016723	1	Load Control Box to Bulkhead Harness	Not Shown
REF	1016724	1	Bulkhead to Generator Harness	Not Shown
REF	1017192	1	Generator Valve Adapter Harness	Not Shown
REF	1008877	1	Jumper Heater Element Harness	Not Shown
REF	1009371	1	Power Crown Harness	Not Shown
REF	1008879	1	Power Crown w/Slope Harness	Not Shown

Control Box Assembly-9 Function Screed Control (1 of 2)

Item No	Part Number	Qty	Description	Remarks
GRP	1018700		Control Box Assembly	
1	1017810	1	Control Box Enclosure	
2	1017811	1	Decal - Control Box Operation	
3	1016158	1	PV480 Display - V3874 T4F	
4	31985	1	Dash Light - Green	
5	31986	1	Dash Light - Blue	
6	1010500	1	Indicator Light - White	
7	39146-14	1	Ignition Switch	
REF	982008-04	1	Ignition Key	
8	851392	6	Toggle Switch, 3-POS, SPDT, MOM	
9	851391	5	Toggle Switch, 2-POS, SPST	
10	37521	2	Toggle Switch, 3-POS, DPDT, MOM	
11	1010672	1	E-Stop Switch	
12	900030	3	Toggle Switch, Auto Conveyor	
13	982249	1	Push Button Switch	
14	851390	1	Toggle Switch, 3-POS, DPDT	
15	851090613	2	Toggle Switch, 3-POS, SPDT	
16	851393	1	Toggle Switch	
17	1015381	1	Connector, 31 Pin, HD34-24-31ST	
18	981916-01	2	Nut, 24 Shell	
19	981916-02	2	Lockwasher, 24 Shell	
20	1014909	1	Receptacle, 19 Pin, HDP20 Series	
21	1011854	1	Connector Nut, HDP20 Series	
22	1011855	1	Connector Lockwasher, HDP20 Series	
23	981916	1	Receptacle, 31 Pin, HD34-24-31ST	
24	1011147	1	12V Cigarette Lighter Receptacle	
25	1010657	1	Panel Mount Connector	
26	989179	1	Plug Connector	
27	983211	1	Wedgelock Connecor, W3P	
28	982456	3	Deutsch Pin	
29	1016261	1	Decal - Calibration	
30	1016260	1	Toggle Switch Mounting Bracket	
31	36086	3	Relay Mounting Bracket	
32	36085	3	Relay, 12V, SPDT, 40A, 5 Pin	
33	1017351	1	Decal - Relay Diagram	
34	20934592	1	Relay, SPST, 75A	
35	989178	1	Connector, 3 Pin, Y Socket	
36	1000649	2	Connector, 3 Pin, DT06-3S-EP11	

Illustrated Parts List

CONTROL BOX ASSEMBLY-9 FUNCTION SCREED CTRL (2 OF 2)

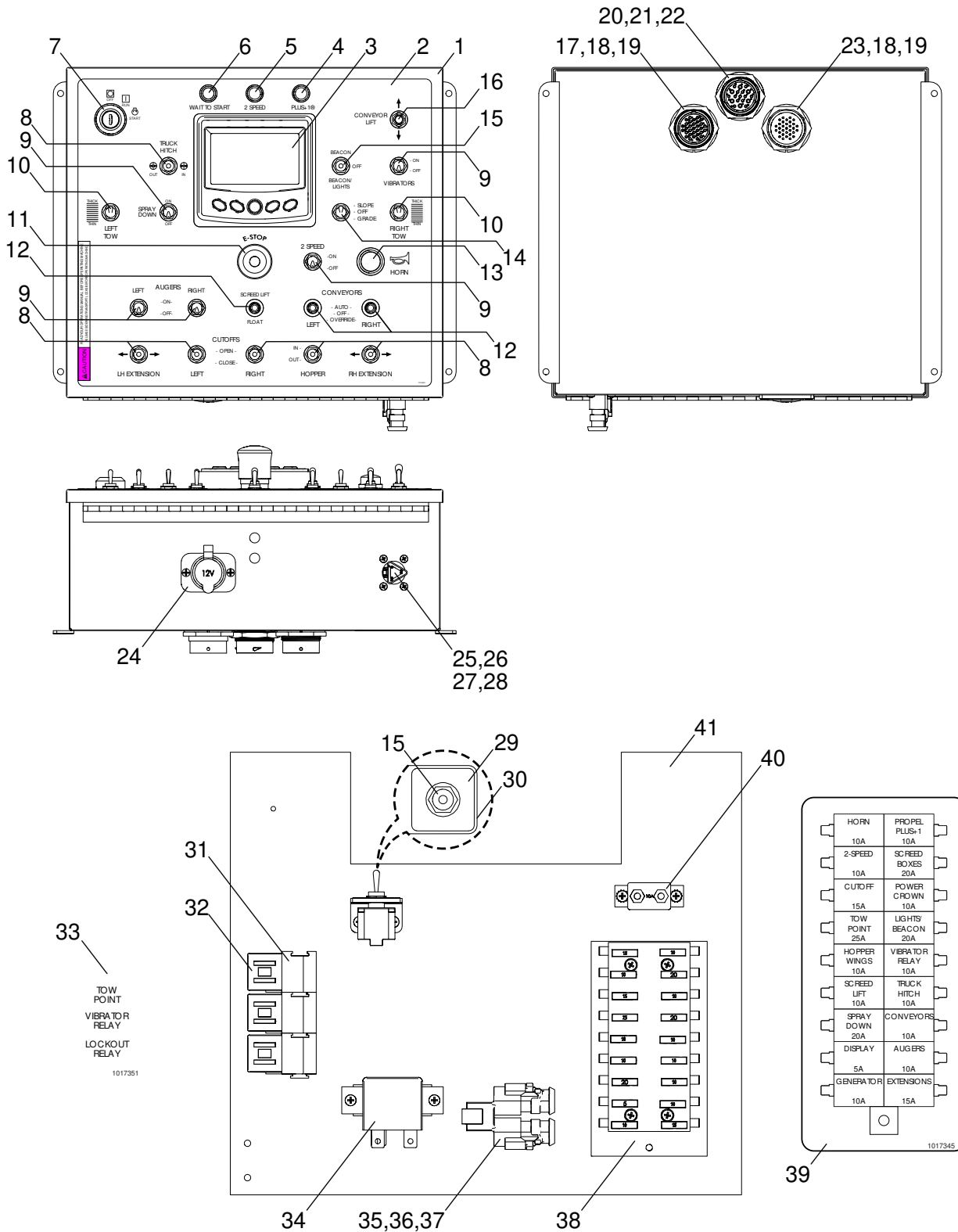

Figure 7-29. Control Box Assembly-9 Function Screed Control (2 of 2)

Control Box Assembly-9 Function Screed Control (2 of 2)

Item No	Part Number	Qty	Description	Remarks
37	983210	2	Connector, 3 Pin, Plug	
38	685060	1	Fuse Block, 18 Gang, ATC	
REF	36746	1	Fuse, 5A, ATC	
REF	36340	11	Fuse, 10A, ATC	
REF	36341	2	Fuse, 15A, ATC	
REF	36342	3	Fuse, 20A, ATC	
REF	37303	1	Fuse, 25A, ATC	
39	1017345	1	Decal - Fuse Diagram	
40	986546	1	Circuit Breaker, 10A w/Mount	
41	1007228-03	1	Panel w/Notch	

HARNESS LIST

REF	1017840	1	Main Harness - 9 Function Screed Control	Not Shown
REF	1016536	1	Lower Manifold Harness	Not Shown
REF	1016263	1	Jumper C4 Dash To Pedestal Harness	Not Shown
REF	1016264	1	Jumper C3 Dash To Pedestal Harness	Not Shown
REF	1016702	1	Hydraulic Cooler Harness	Not Shown
REF	1016723	1	Load Control Box to Bulkhead Harness	Not Shown
REF	1016724	1	Bulkhead to Generator Harness	Not Shown
REF	1017192	1	Generator Valve Adapter Harness	Not Shown
REF	1008877	1	Jumper Heater Element Harness	Not Shown
REF	1009371	1	Power Crown Harness	Not Shown
REF	1008879	1	Power Crown w/Slope Harness	Not Shown
REF	1017774	4	Watlow Temperature Harness	Not Shown

Illustrated Parts List

SEAT ASSEMBLY & DETAILS

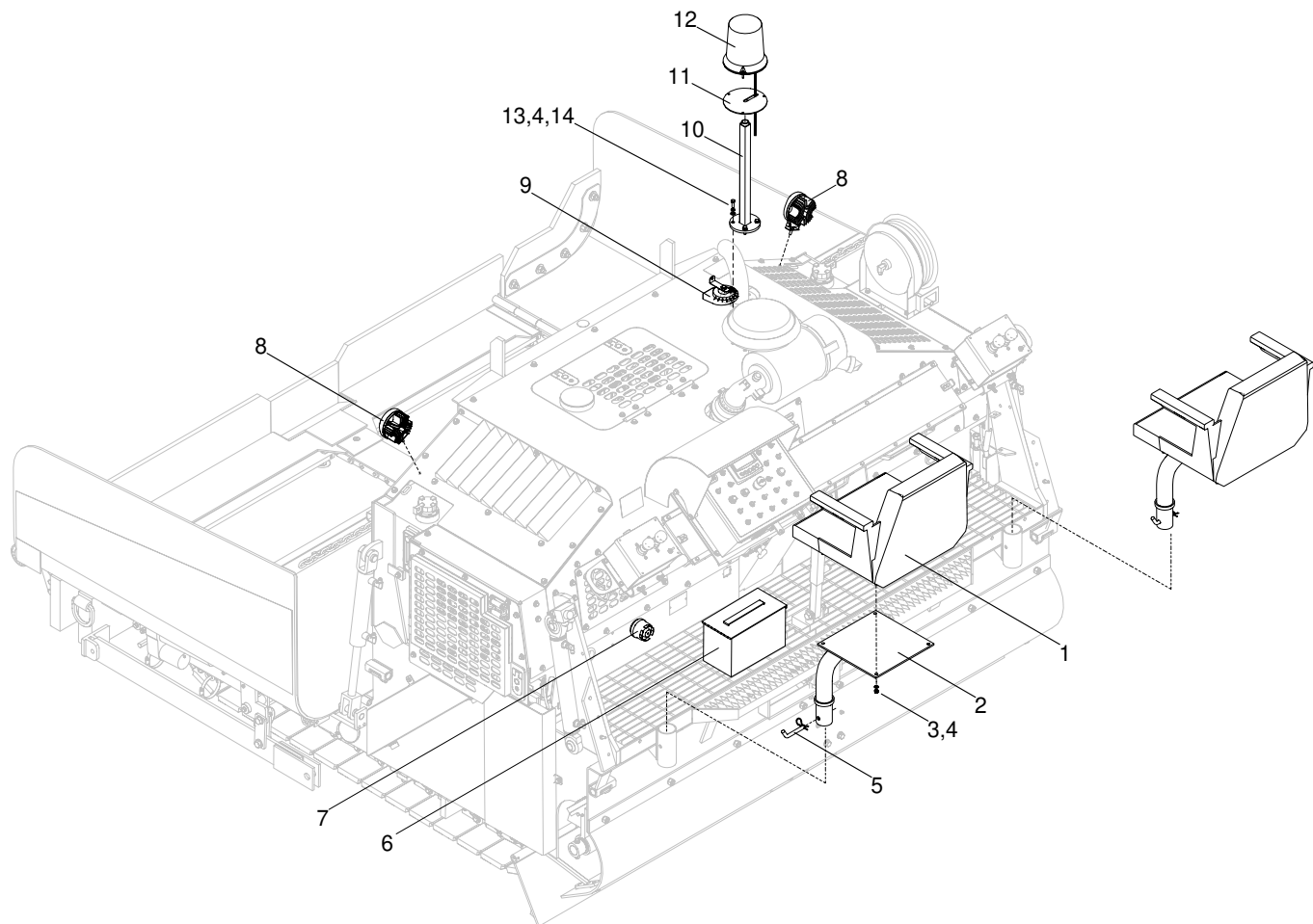

Figure 7-30. Seat Assembly & Details

Seat Assembly & Details

Item No	Part Number	Qty	Description	Remarks
REF	1016967	2	Seat Assembly w/Short Post	Includes Items 1-5
1	360010	2	White Seat Assembly w/Armrest	
2	988640SRV	2	Seat Post Assembly - Short	
3	200-5-18-5	8	Nut, Hex, 5/16-18, GR5	
4	302-5	12	Washer, Lock, 5/16	
5	72836	2	Pin, 1/2 x 3.00 w/Cotter Pin	
REF	984862	8	Vinyl Cap, Black	
6	853963	1	Tool Box	
7	160320	1	Back Up Alarm, 107 dB	
8	1013307	2	Circular LED Light w/Deutsch Connector	
9	20190773	1	Horn, Low Pitch	
10	989469SRV	1	Beacon Light Post Assembly	
11	1013234	1	Beacon Mount	
12	1013231	1	Beacon Light, LED Amber Strobe	
13	100-5-18-16-5	4	CSHH, 5/16-18 x 1.00, GR5	
14	300-5	4	Washer, Flat, SAE, 5/16	

Illustrated Parts List

HD SCREED OVERVIEW - SLOPING AND NON-SLOPING

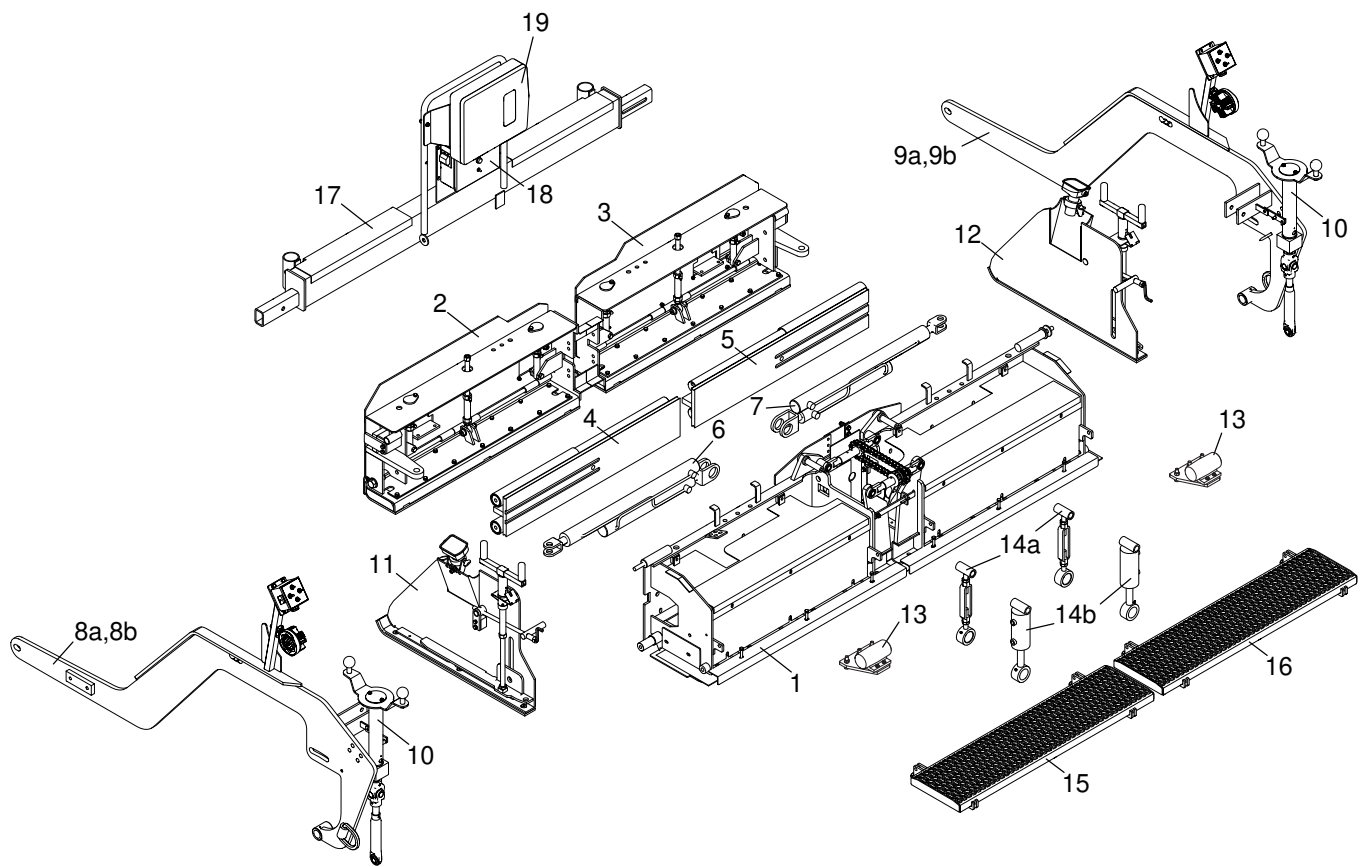

Figure 7-31. HD Screed Overview, Sloping and Non-Sloping

HD Screed Overview, Sloping and Non-Sloping

Item No	Reference Figure	Description	Remarks
1	7-32,7-33	HD Screed Frame Assembly	
2	7-34	HD Screed Extension Assembly - Left	
3	7-35	HD Screed Extension Assembly - Right	
4	7-36	HD Screed Slide Plate Assembly	
5	7-36	HD Screed Slide Plate Assembly	
6	7-33	Hydraulic Cylinder - Left	
7	7-33	Hydraulic Cylinder - Right	
8a	7-37	HD Screed Pull Arm Assembly, 4 Function - Left	
8b	7-39	HD Screed Pull Arm Assembly, 9 Function - Left	
9a	7-38	HD Screed Pull Arm Assembly, 4 Function - Right	
9b	7-40	HD Screed Pull Arm Assembly, 9 Function - Right	
10	7-41	HD Screed Thickness Adjuster - Standard	
11	7-42	HD Screed Endgate Assembly, Standard- Left	
12	7-42	HD Screed Endgate Assembly, Standard - Right	
13	7-43	Electric Screed Vibrator	
14a	7-33	Manual Turnbuckle Assembly	Non-Slope
14b	7-33	Hydraulic Cylinder	Slope
15	7-43	Grip Strut Walkboard Assembly - Left	
16	7-43	Grip Strut Walkboard Assembly - Right	
17	7-44	Citrus Tank Assembly	
18	7-45	Screed Control Assembly	
19	7-44	Manual Case/Mounting Bracket	

Illustrated Parts List

HD SCREED FRAME ASSEMBLY (1 OF 2)

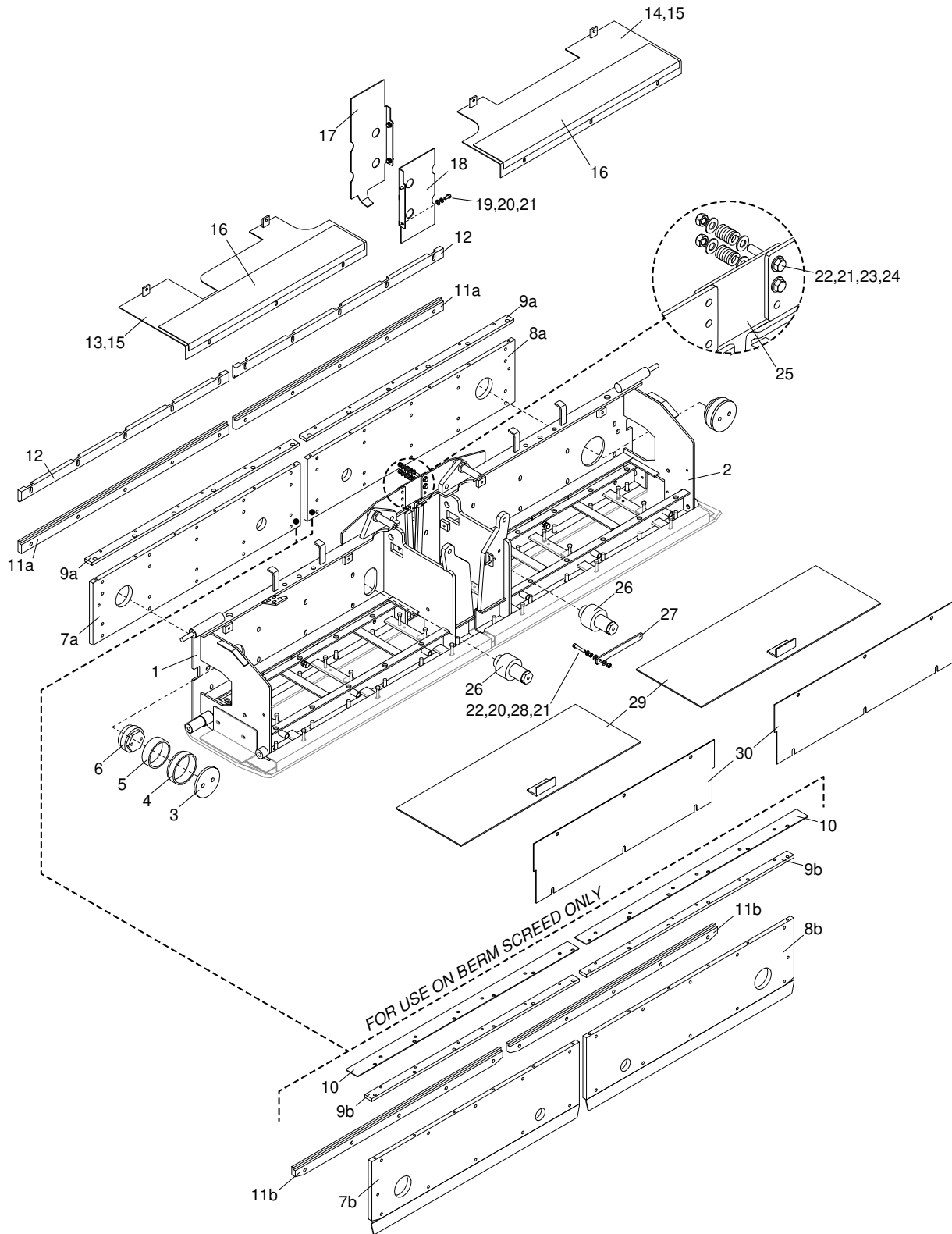

Figure 7-32. HD Screed Frame Assembly (1 of 2)

HD Screed Frame Assembly (1 of 2)

Item No	Part Number	Qty	Description	Remarks
1	1006993	1	Inner Plate Assembly - Left	
2	1006994	1	Inner Plate Assembly - Right	
3	981711	2	Pivot Cover Plate	
4	981660	2	Pivot Housing Tube	
5	981838	2	Slope Pivot Poly Bushing	
6	981659	2	Slope Pin	
7a	1008663SRV	1	Rail Mount Weldment - Left	HD Std Screed Only
7b	1015424SRV	1	Pivot Plate Weldment - Left	HD Berm Screed Only
8a	1008662SRV	1	Rail Mount Weldment - Right	HD Std Screed Only
8b	1015412SRV	1	Pivot Plate Weldment - Right	HD Berm Screed Only
9a	1006424	2	Slide Locking Bar	HD Std Screed Only
9b	1015319	2	Extension Hold Down Bar	HD Berm Screed Only
10	1015323	2	Asphalt Blocker Plate - Upper	HD Berm Screed Only
11a	1017614	2	L-Shape Extension Slide Rail - Bottom	HD Std Screed Only
11b	1018243	2	L-Shape Extension Slide Rail - Bottom	HD Berm Screed Only
12	1017612	2	L-Shape Extension Slide Rail - Top	
13	1006405	1	Upper Screed Cover - Left	
14	1006406	1	Upper Screed Cover - Right	
15	855759	4	Bar, .25 x 1.25 x 1.50 w/Hole	Weld On for Items 11,12
16	985168	2	Aluminum Diamond Plate Step	
17	1014028	1	Bolt-On Asphalt Shield	
18	1015171	1	Bolt-On Asphalt Shield Plate	
19	100-6-16-12-5F	2	CSHH, 3/8-16 x .75, GR5, FT	
20	302-6	3	Washer, Lock, 3/8	
21	300-6	6	Washer, Flat, SAE, 3/8	
22	100-6-16-32-5	2	CSHH, 3/8-16 x 2.00, GR5	
23	1015173	2	Upper Asphalt Shield Spring	
24	204-6-16-5	2	Nut, Lock, Stover, 3/8-16, GR5	
25	1015172	1	Bolt-On Upper Asphalt Shield Plate	
26	981661	2	Cylinder Mounting Pin	
27	1007232	1	Crown & Valley Gauge Bar	
28	200-6-16-5	2	Nut, Hex, 3/8-16, GR5	
29	1011697	2	Screed Cover Weldment	
30	1007000	2	Lower Screed Cover	

Illustrated Parts List

HD SCREED FRAME ASSEMBLY (2 OF 2)

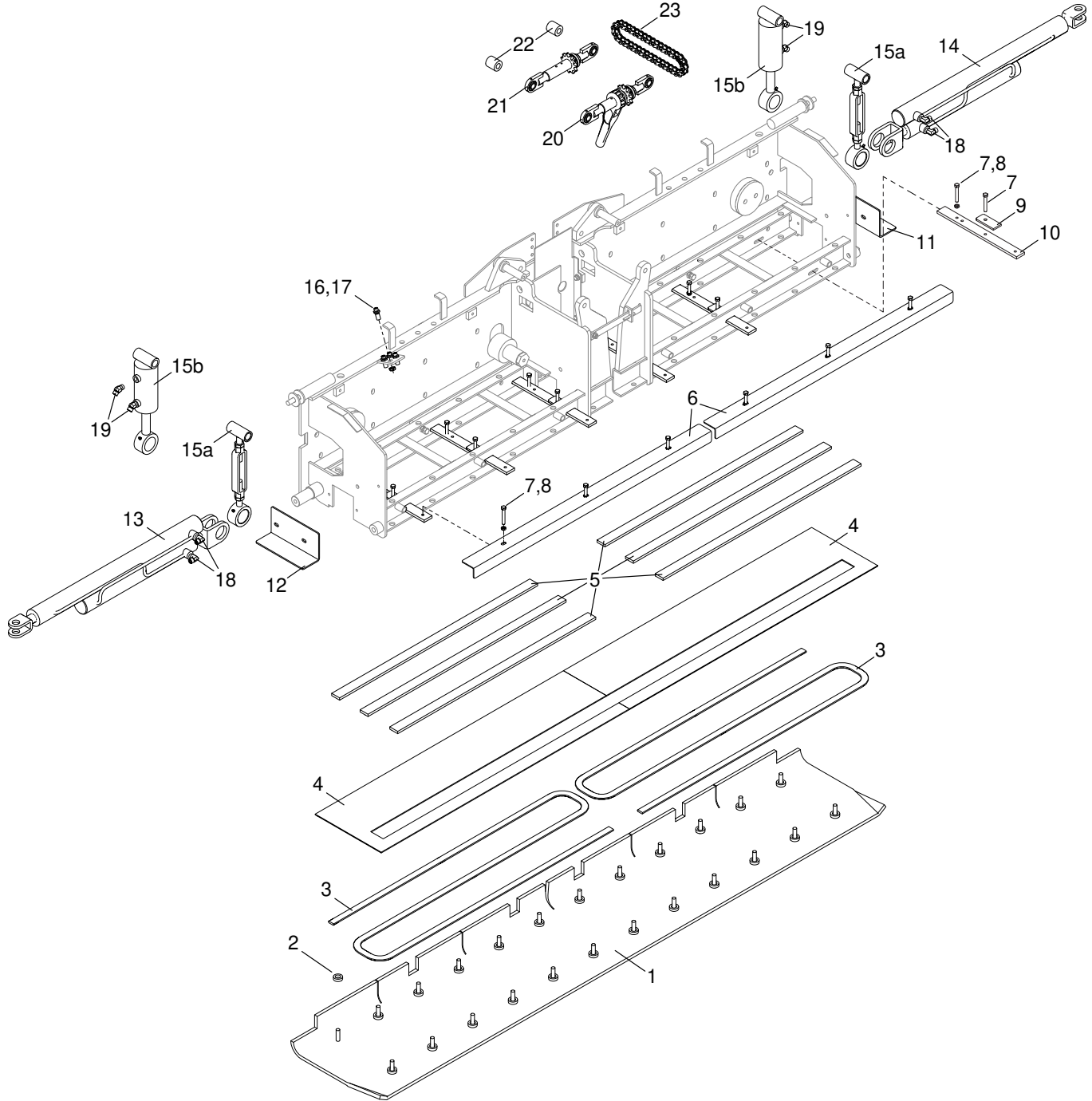

Figure 7-33. HD Screed Frame Assembly (2 of 2)

HD Screed Frame Assembly (2 of 2)

Item No	Part Number	Qty	Description	Remarks
1	1016475	1	Wear Plate w/Studs, 3/8"	
2	1007001	24	Wear Plate Spacer	
3	1015016	2	S-Style Heating Element, 2000W/240V	
4	1015018	2	HD Screed Insulation	
5	1016582	6	Bar, .375 x 1.50 x 37.50	
6	1016477	2	S-Style Element Cover	
7	100-6-16-40-5	18	CSHH, 38-16 x 2.50, GR5	
8	202-6-16-5	18	Nut, Hex, Jam, 3/8-16, GR5	
9	1016480	6	S-Style Element Stop Bar	
10	1016476	6	S-Style Element Hold Down Bar	
11	1016481	1	S-Style Element End Cover - Right	
12	1016483	1	S-Style Element End Cover - Left	
13	981710L	1	Hydraulic Cylinder, 2.00 x 2.00 x 42.00 x 1.25 Rod	
14	981710R	1	Hydraulic Cylinder, 2.00 x 2.00 x 42.00 x 1.25 Rod	
15a	1016151	2	Manual Turnbuckle Assembly	Standard
15b	983421	2	Hydraulic Cylinder, 2.75 x 2.00 x 1.125 Rod	Option - Hydraulic Slope
16	FS2700-06-06	4	Bulkhead Union Adapter, -6 ORFS/-6 ORFS	
17	FS0306-06	4	Bulkhead Lock Nut, -6 ORFS	
18	FS2501-06-06-FG	4	Elbow Adapter, 90°, -6 ORFS/-6 NPTF	
19	FS2503-06-06-FG	4	Elbow Adapter, 90°, -6 ORFS/-6 NPTF	
GRP	1007212		Group - Mechanical Crown	
20	1009439	1	Crown & Valley Assembly	
21	1009440	1	Crown & Valley Turnbuckle Assembly	
22	1006419	2	Crown Mounting Spacer	
23	1008047	1	Roller Chain, 60H x 39P w/Half-Link & Masterlink	

Illustrated Parts List

HD SCREED EXTENSION ASSEMBLY - LEFT

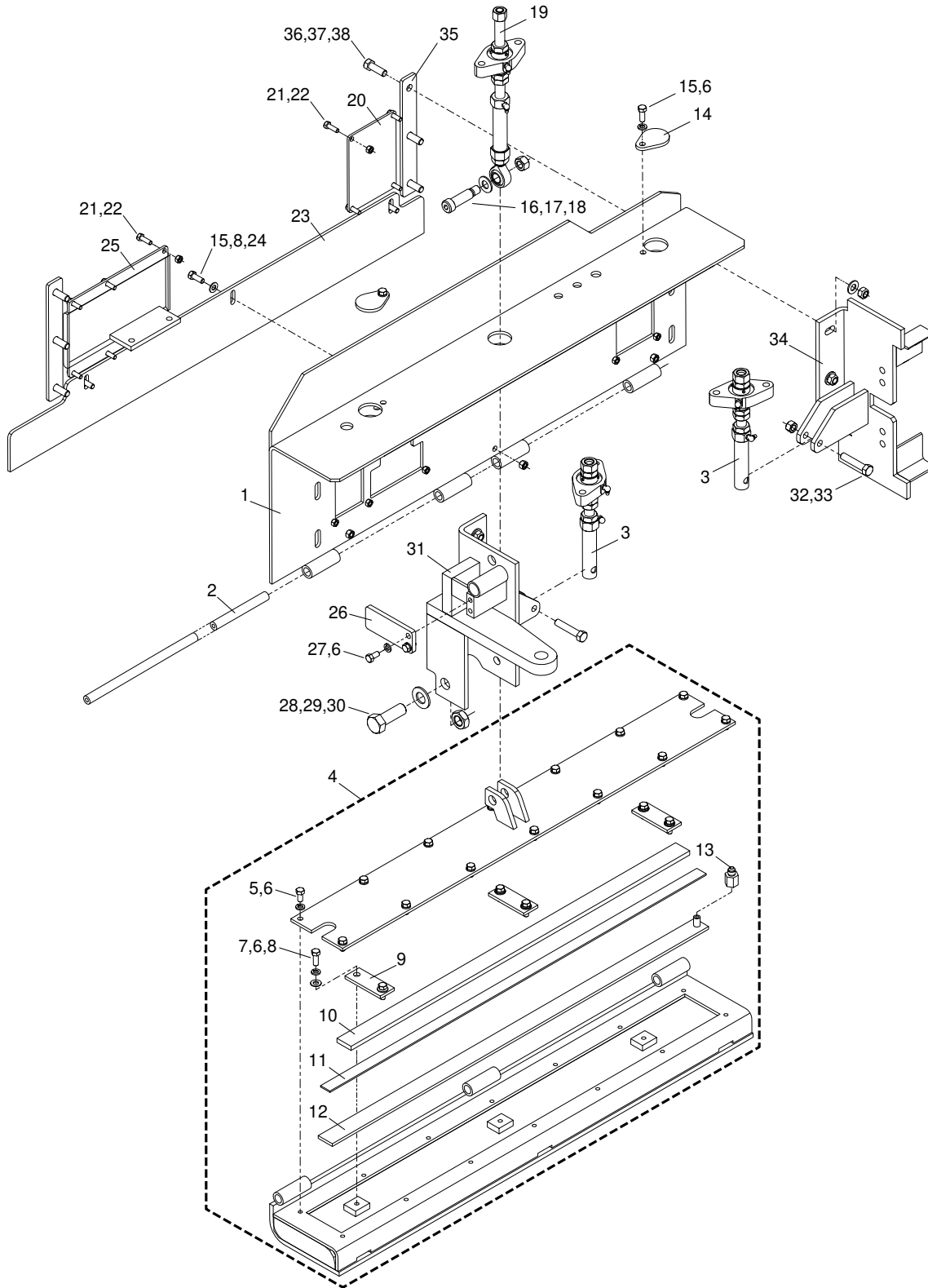

Figure 7-34. HD Screed Extension Assembly - Left

HD Screed Extension Assembly - Left

Item No	Part Number	Qty	Description	Remarks
REF	1006378SRV	1	Screed Extension Assembly - Left	Includes All Items
1	1009632	1	Screed Extension Front Assembly - Left	Includes Items 2 - 28
2	854447SRV	1	Shaft, ϕ .688 x 43.50	
3	1006390	2	Vertical Adjuster Assembly	
4	1006380SRV	1	Extension Heatbox Assembly - Left	Includes Items 5 - 11
5	100-6-16-12-5F	14	CSHH, 3/8-16 x .75, GR5, FT	
6	302-6	24	Washer, Lock, 3/8	
7	100-6-24-16-5F	6	CSHH, 3/8-24 x 1.00, GR5, FT	
8	300-6	9	Washer, Flat, SAE, 3/8	
9	985123	3	Screed Extension Element Clamp	
10	985120	1	Bar, .25 x 1.50 x 36	
11	986522	1	Insulation, .25 x 1.00 x 12.00 w/Adhesive	
12	987890SRV	1	Heating Element, 1000W/220V, 41"	
13	2405-6-6	1	Adapter, Connector, -6 JIC / -6 NPTF	
14	1006439	2	Extension Adjuster Cover	
15	100-6-16-16-5F	5	CSHH, 3/8-16 x 1.00, GR5, FT	
16	118-12-28-5/8x11	1	Shoulder Bolt, ϕ 3/4 x 1.75L, 5/8-11	
17	300-12	1	Washer, Flat, SAE, 3/4	
18	200-10-11-5	1	Nut, Hex, 5/8-11, GR5	
19	1006401	1	AOA Adjuster Assembly	
20	1006398	1	Extension Access Cover Plate	
21	100-5-18-16-5F	10	CSHH, 5/16-18 x 1.00, GR5, FT	
22	200-5-18-5	10	Nut, Hex, 5/16-18, GR5	
23	1006400	1	Extension Strikeoff Plate	
24	200-6-16-5	3	Nut, Hex, 3/8-16, GR5	
25	1008664	1	Extension Vibrator Weldment	
26	1006536	1	Endgate Bracket Plate w/Holes	
27	100-6-24-12-5F	2	CSHH, 3/8-24 x .75, GR5, FT	
28	100-14-9-40-5	1	CSHH, 7/8-9 x 2.50, GR5	
29	300-14	1	Washer, Flat, SAE, 7/8	
30	202-14-9-5	1	Nut, Jam, 7/8-9, GR5	
31	1007096SRV	1	Outer Extension Assembly - Left	
32	100-8-13-40-5	2	CSHH, 1/2-13 x 2.50, GR5	
33	200-8-13-5	2	Nut, Hex, 1/2-13, GR5	
34	1007097SRV	1	Inner Extension Assembly - Left	
35	1006395	2	Vertical Lift Bar	
36	100-8-13-28-5	6	CSHH, 1/2-13 x 1.50, GR5	
37	300-8	6	Washer, Flat, SAE, 1/2	
38	204-8-13-5	6	Nut, Lock, Stover, 1/2-13, GR5	
REF	1015990SRV	A/R	Extension Element Hose & Wiring Kit	

HD Screed Extension Assembly - Right

Item No	Part Number	Qty	Description	Remarks
REF	1006379SRV	1	Screed Extension Assembly - Right	Includes All Items
1	1009631	1	Screed Extension Front Assembly - Right	Includes Items 2 - 28
2	854447SRV	1	Shaft, ø.688 x 43.50	
3	1006390	2	Vertical Adjuster Assembly	
4	1006380SRV	1	Extension Heatbox Assembly - Right	Includes Items 5 - 11
5	100-6-16-12-5F	14	CSHH, 3/8-16 x .75, GR5, FT	
6	302-6	24	Washer, Lock, 3/8	
7	100-6-24-16-5F	6	CSHH, 3/8-24 x 1.00, GR5, FT	
8	300-6	9	Washer, Flat, SAE, 3/8	
9	985123	3	Screed Extension Element Clamp	
10	985120	1	Bar, .25 x 1.50 x 36	
11	986522	1	Insulation, .25 x 1.00 x 12.00 w/Adhesive	
12	987890SRV	1	Heating Element, 1000W/220V, 41"	
13	2405-6-6	1	Adapter, Connector, -6 JIC / -6 NPTF	
14	1006439	2	Extension Adjuster Cover	
15	100-6-16-16-5F	5	CSHH, 3/8-16 x 1.00, GR5, FT	
16	118-12-28-5/8x11	1	Shoulder Bolt, ø3/4 x 1.75L, 5/8-11	
17	300-12	1	Washer, Flat, SAE, 3/4	
18	200-10-11-5	1	Nut, Hex, 5/8-11, GR5	
19	1006401	1	AOA Adjuster Assembly	
20	1006398	1	Extension Access Cover Plate	
21	100-5-18-16-5F	10	CSHH, 5/16-18 x 1.00, GR5, FT	
22	200-5-18-5	10	Nut, Hex, 5/16-18, GR5	
23	1006400	1	Extension Strikeoff Plate	
24	200-6-16-5	3	Nut, Hex, 3/8-16, GR5	
25	1008664	1	Extension Vibrator Weldment	
26	1006536	1	Endgate Bracket Plate w/Holes	
27	100-6-24-12-5F	2	CSHH, 3/8-24 x .75, GR5, FT	
28	100-14-9-40-5	1	CSHH, 7/8-9 x 2.50, GR5	
29	300-14	1	Washer, Flat, SAE, 7/8	
30	202-14-9-5	1	Nut, Jam, 7/8-9, GR5	
31	1007098SRV	1	Outer Extension Assembly - Right	
32	100-8-13-40-5	2	CSHH, 1/2-13 x 2.50, GR5	
33	200-8-13-5	2	Nut, Hex, 1/2-13, GR5	
34	1007099SRV	1	Inner Extension Assembly - Right	
35	1006395	2	Vertical Lift Bar	
36	100-8-13-28-5	6	CSHH, 1/2-13 x 1.50, GR5	
37	300-8	6	Washer, Flat, SAE, 1/2	
38	204-8-13-5	6	Nut, Lock, Stover, 1/2-13, GR5	
REF	1015990SRV	A/R	Extension Element Hose & Wiring Kit	

Illustrated Parts List

HD SCREED SLIDE PLATE ASSEMBLY

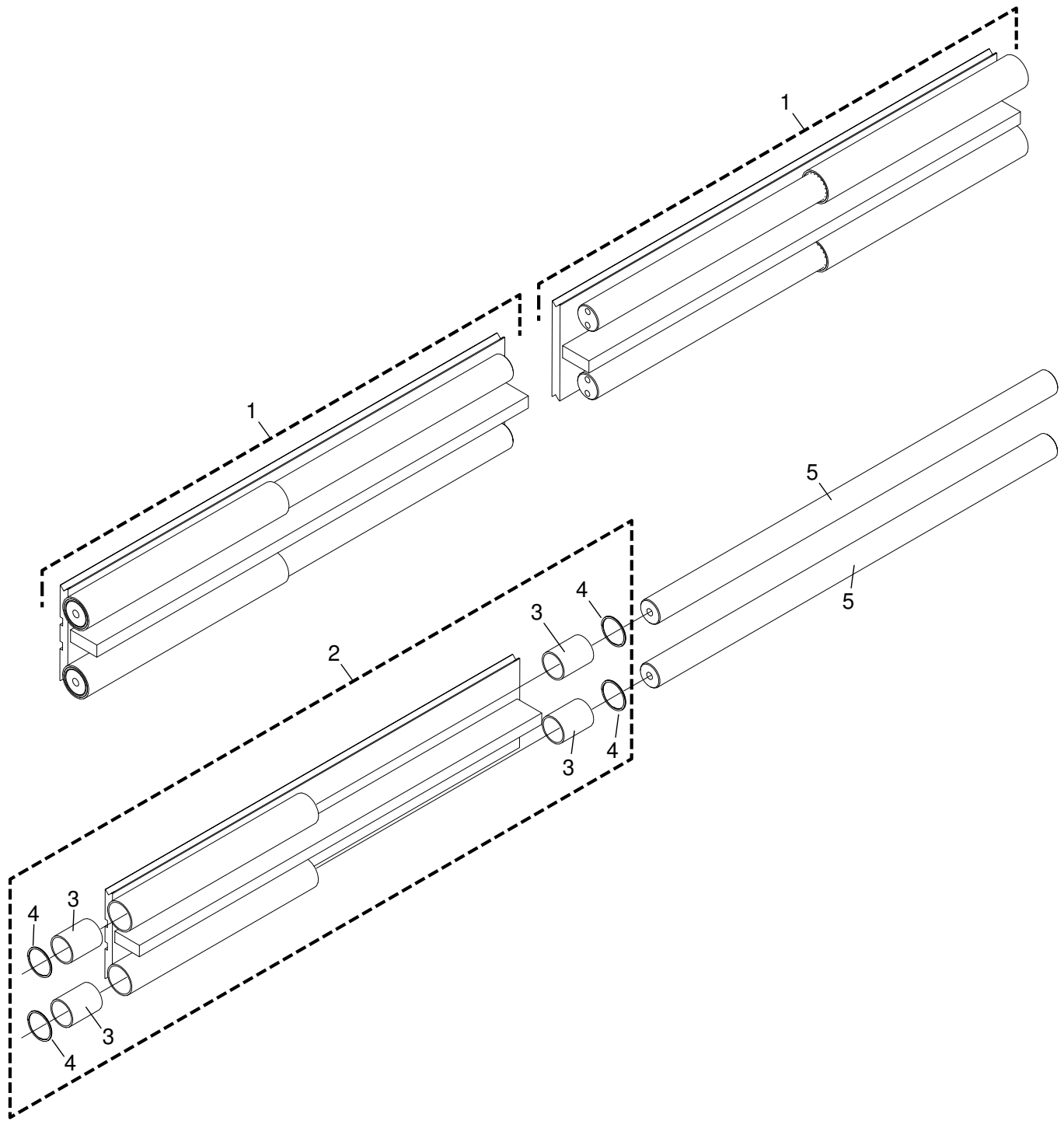

Figure 7-36. HD Screed Slide Plate Assembly

HD Screed Slide Plate Assembly

Item No	Part Number	Qty	Description	Remarks
1	1006416	2	HD Slide w/Shaft Assembly	
2	1006445	2	HD Slide w/o Shaft Assembly	(1) Per Assembly
3	1006417	8	Fiber Bushing, 2.00 ID x 2.25 OD	(4) Per Assembly
4	980380	8	Spiral Internal Spring, 2.00 ID Shaft	(4) Per Assembly
5	1006415	4	HD Chromed Screed Extension Shaft	(2) Per Assembly

Illustrated Parts List

HD SCREED PULL ARM ASSEMBLY, 4 FUNCTION - LEFT

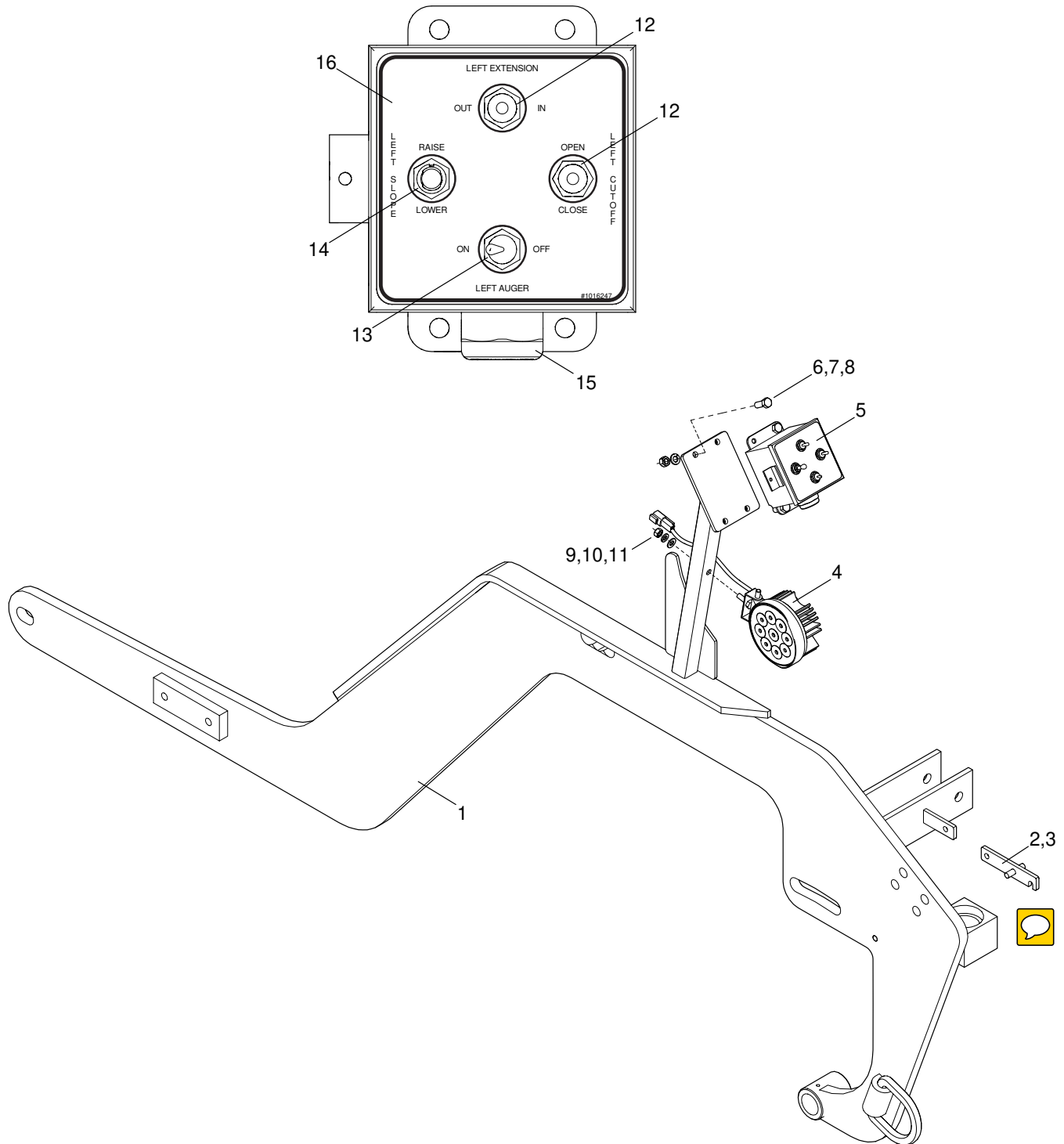

Figure 7-37. HD Screed Pull Arm Assembly, 4 Function - Left

HD Screed Pull Arm Assembly, 4 Function - Left

Item No	Part Number	Qty	Description	Remarks
1	1006437SRV	1	SLP Screed Arm Assembly - Left	Includes Items 2,3
2	855504	1	Bar, 1/4 x 1 x 5	
3	855496	1	Shaft, 3/8 CR x 1-1/2	
4	1013307	1	LED Circular Light w/Deutsch Connector	
5	1016618	1	Screed Control Box, 4 Switch - Left	
6	100-6-16-16-5F	4	CSHH, 3/8-16 x 1.00, GR5, FT	
7	302-6	4	Washer, Lock, 3/8	
8	200-6-16-5	4	Nut, Hex, 3/8-16, GR5	
9	200-5-18-5	1	Nut, Hex, 5/16-18, GR5	
10	302-5	1	Washer, Lock, 5/16	
11	300-5	1	Washer, Flat, SAE, 5/16	
12	851392	2	Toggle Switch, 3-POS, SPDT, MOM	
13	851391	1	Toggle Switch, 2-POS	2-Speed, High/Low
14	851393	1	Toggle Switch	
15	3400DI	1	Water Tight Connector, 3/4 x 3/4 MPT	
16	1016247	1	Decal - Screed Control Operation - Left	

Illustrated Parts List

HD SCREED PULL ARM ASSEMBLY, 4 FUNCTION - RIGHT

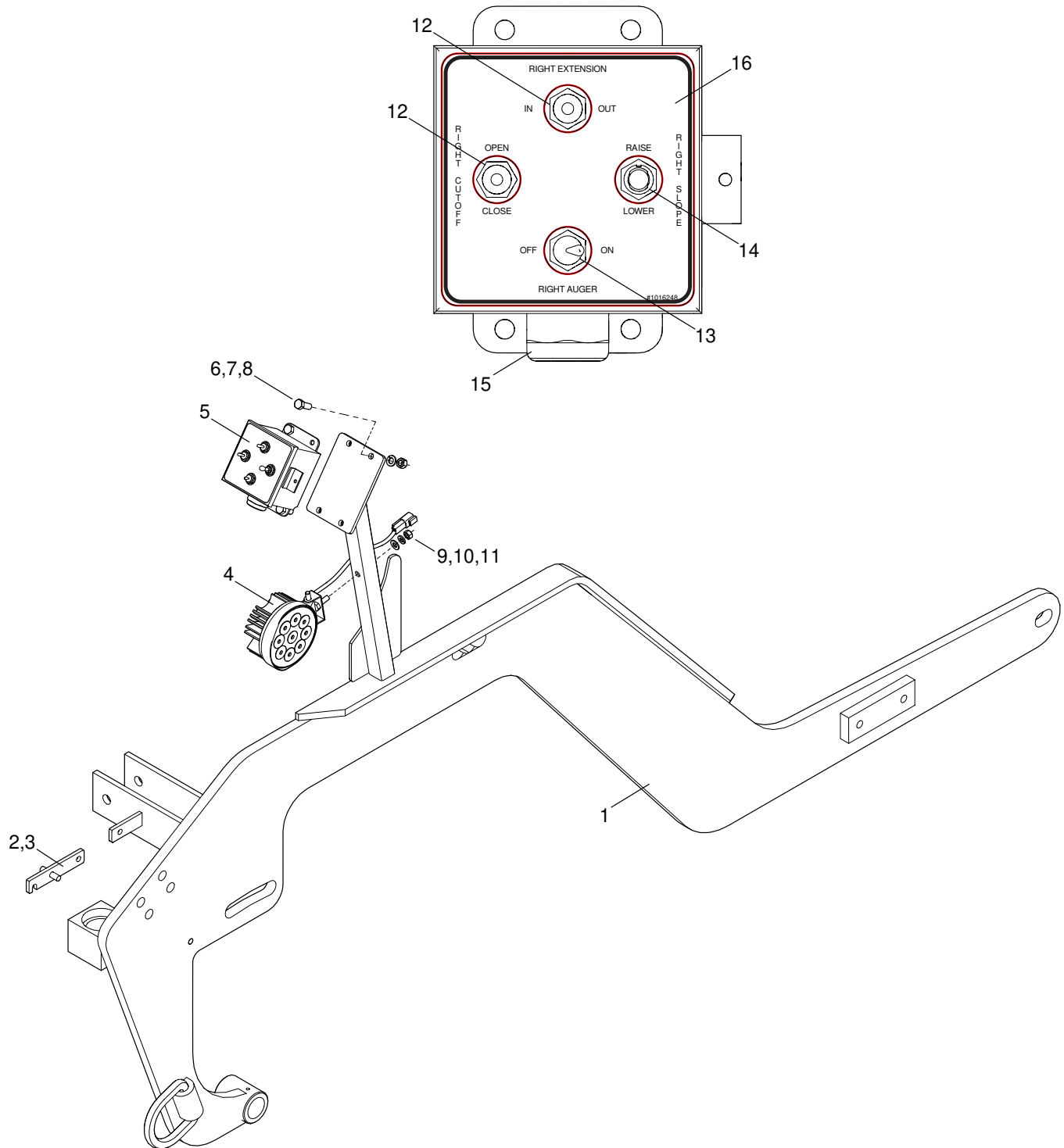

Figure 7-38. HD Screed Pull Arm Assembly, 4 Function - Right

HD Screed Pull Arm Assembly, 4 Function - Right

Item No	Part Number	Qty	Description	Remarks
1	1006438SRV	1	SLP Screed Arm Assembly - Right	Includes Items 2,3
2	855504	1	Bar, 1/4 x 1 x 5	
3	855496	1	Shaft, 3/8 CR x 1-1/2	
4	1013307	1	LED Circular Light w/Deutsch Connector	
5	1016617	1	Screed Control Box, 4 Switch - Right	
6	100-6-16-16-5F	4	CSHH, 3/8-16 x 1.00, GR5, FT	
7	302-6	4	Washer, Lock, 3/8	
8	200-6-16-5	4	Nut, Hex, 3/8-16, GR5	
9	200-5-18-5	1	Nut, Hex, 5/16-18, GR5	
10	302-5	1	Washer, Lock, 5/16	
11	300-5	1	Washer, Flat, SAE, 5/16	
12	851392	2	Toggle Switch, 3-POS, SPDT, MOM	
13	851391	1	Toggle Switch, 2-POS	2-Speed, High/Low
14	851393	1	Toggle Switch	
15	3400DI	1	Water Tight Connector, 3/4 x 3/4 MPT	
16	1016248	1	Decal - Screed Control Operation - Right	

Illustrated Parts List

HD SCREED PULL ARM ASSEMBLY, 9 FUNCTION - LEFT

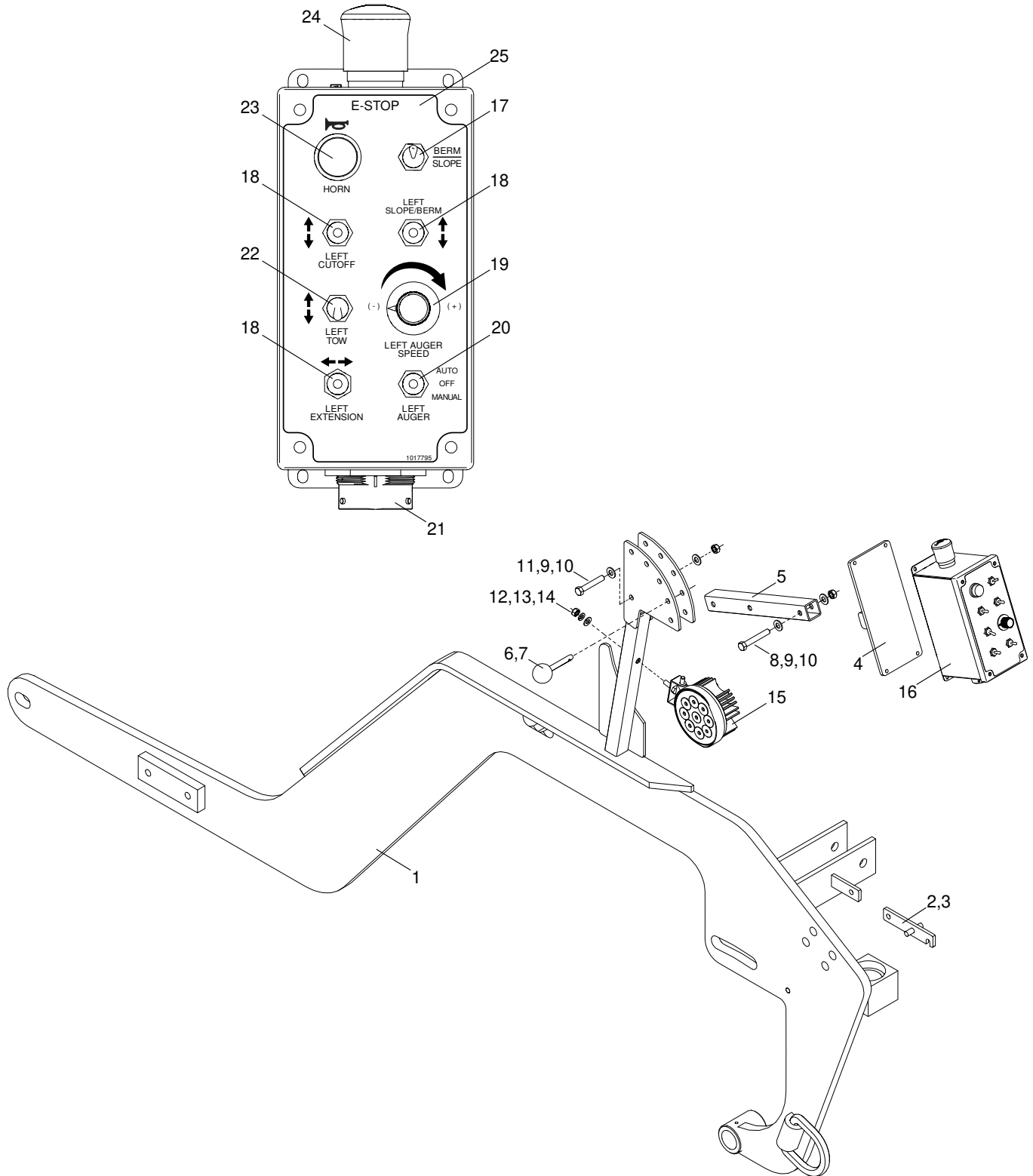

Figure 7-39. HD Screed Pull Arm Assembly, 9 Function - Left

HD Screed Pull Arm Assembly, 9 Function - Left

Item No	Part Number	Qty	Description	Remarks
1	1017801	1	Screed Arm Weldment, Adjustable - Left	Includes All Items
2	855504	1	Bar, 1/4 x 1 x 5	
3	855496	1	Shaft, 3/8 CR x 1-1/2	
4	1017803	1	Screed Control Box Mount	
5	1008917	1	Pivot Tube	
6	851156	1	Round Knob, 1.375 x 3/8-16	
7	1008934	1	Quick Release Pin	
8	100-6-16-40-5	1	CSHH, 3/8-16 x 2.50, GR5	
9	300-6	4	Washer, Flat, SAE, 3/8	
10	204-6-16-5	2	Nut, Lock, Stover, 3/8-16, GR5	
11	100-6-16-36-5	1	CSHH, 3/8-16 x 2.25, GR5	
12	200-5-18-5	1	Nut, Hex, 5/16-18, GR5	
13	302-5	1	Washer, Lock, 5/16	
14	300-5	1	Washer, Flat, SAE, 5/16	
15	1013307	1	LED Circular Light w/Deutsch Connector	
16	1017791	1	Screed Control Box Assembly, 9 Function - Left	Includes Items 18-25
17	851391	1	Toggle Switch, 2-POS	2-Speed, High/Low
18	851392	3	Toggle Switch, 3-POS, SPDT, MOM	
19	35049	1	Knob	
REF	1010077	1	Rheostat, 35 Ohm/25W	Not Shown
20	851090613	1	Toggle Switch, SPDT, 3-POS	
21	1015381	1	Connector, 31 Pin, HD34-24-31ST	
22	37521	1	Toggle Switch, DPDT, 3-POS, MOM	
23	982249	1	Push Button Switch	
24	1010672	1	Emergency Stop Switch, 1-NC	
25	1017795	1	Decal - Screed Control - Left	

Illustrated Parts List

HD SCREED PULL ARM ASSEMBLY, 9 FUNCTION - RIGHT

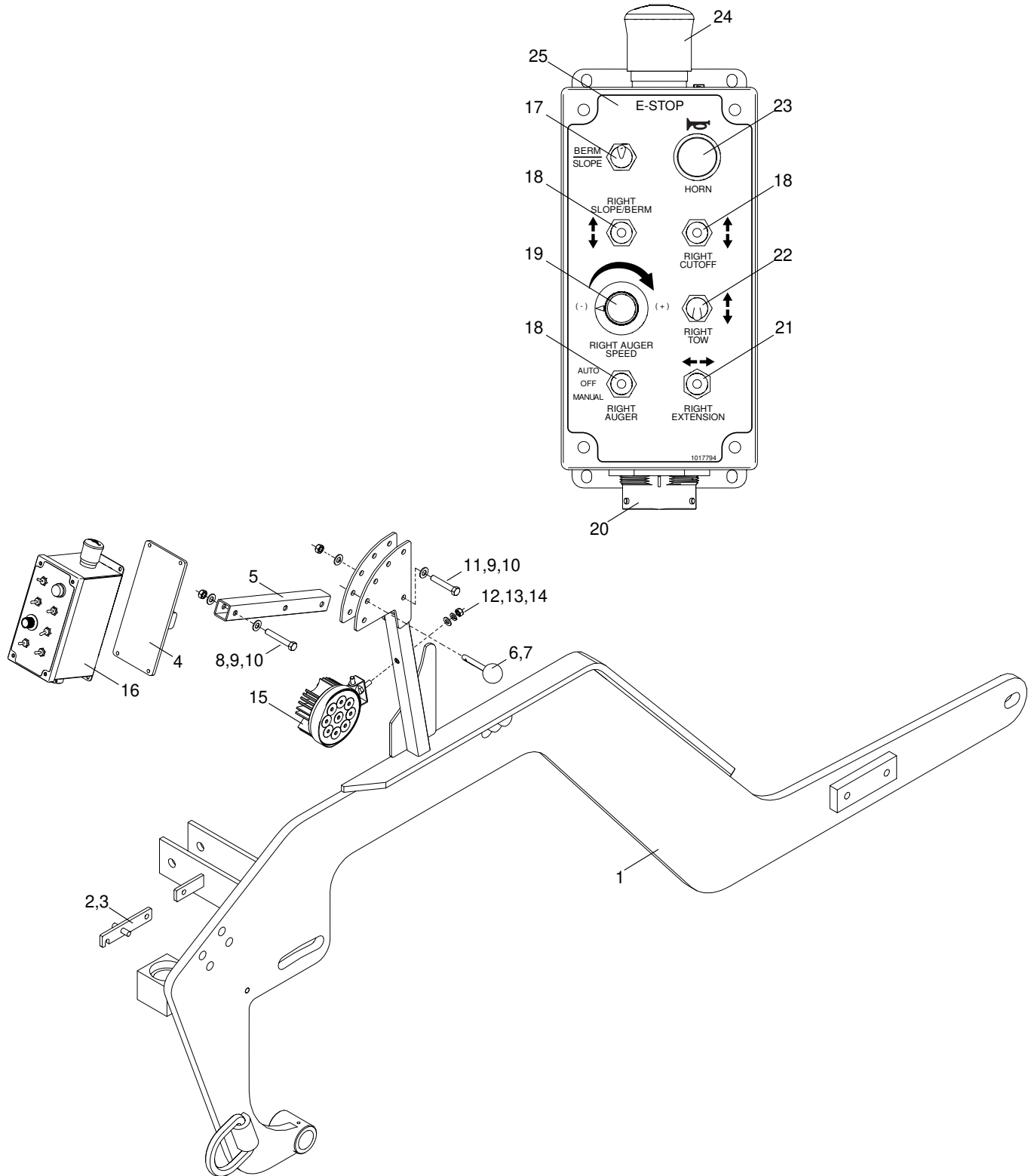

Figure 7-40. HD Screed Pull Arm Assembly, 9 Function - Right

HD Screed Pull Arm Assembly, 9 Function - Right

Item No	Part Number	Qty	Description	Remarks
1	1017802	1	Screed Arm Weldment, Adjustable - Right	Includes All Items
2	855504	1	Bar, 1/4 x 1 x 5	
3	855496	1	Shaft, 3/8 CR x 1-1/2	
4	1017803	1	Screed Control Box Mount	
5	1008917	1	Pivot Tube	
6	851156	1	Round Knob, 1.375 x 3/8-16	
7	1008934	1	Quick Release Pin	
8	100-6-16-40-5	1	CSHH, 3/8-16 x 2.50, GR5	
9	300-6	4	Washer, Flat, SAE, 3/8	
10	204-6-16-5	2	Nut, Lock, Stover, 3/8-16, GR5	
11	100-6-16-36-5	1	CSHH, 3/8-16 x 2.25, GR5	
12	200-5-18-5	1	Nut, Hex, 5/16-18, GR5	
13	302-5	1	Washer, Lock, 5/16	
14	300-5	1	Washer, Flat, SAE, 5/16	
15	1013307	1	LED Circular Light w/Deutsch Connector	
16	1017792	1	Screed Control Box Assembly, 9 Function - Right	Includes Items 17-25
17	851391	1	Toggle Switch, 2-POS	2-Speed, High/Low
18	851392	3	Toggle Switch, 3-POS, SPDT, MOM	
19	35049	1	Knob	
REF	1010077	1	Rheostat, 35 Ohm/25W	Not Shown
20	1015381	1	Connector, 31 Pin, HD34-24-31ST	
21	851090613	1	Toggle Switch, SPDT, 3-POS	
22	37521	1	Toggle Switch, DPDT, 3-POS, MOM	
23	982249	1	Push Button Switch	
24	1010672	1	Emergency Stop Switch, 1-NC	
25	1017794	1	Decal - Screed Control - Right	

Illustrated Parts List

HD SCREED THICKNESS ADJUSTER - STANDARD

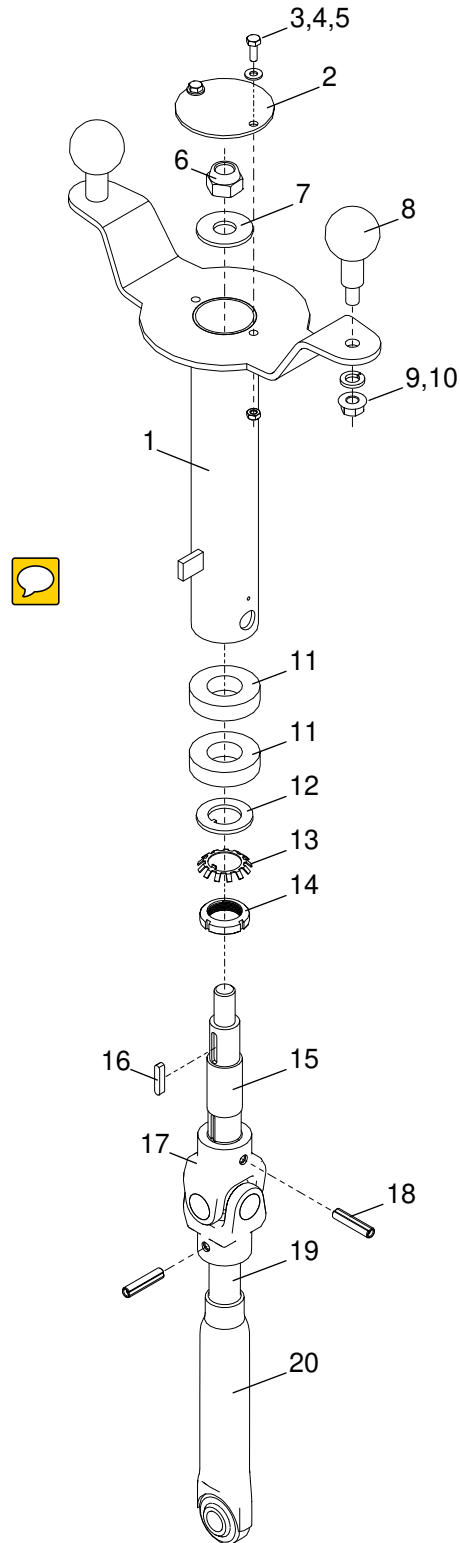

Figure 7-41. HD Screed Thickness Adjuster - Standard

HD Screenshot Thickness Adjuster - Standard

Item No	Part Number	Qty	Description	Remarks
GRP	1007206	1	Group - Standard Depth Screws	
REF	1011374SRV	2	Screenshot Thickness Adjuster Assembly	
1	1011375SRV	2	Thickness Adjuster Handle Weldment	(1) Per Assembly
2	1006434	2	Adjuster Screw Cap	(1) Per Assembly
3	100-4-20-12-5F	4	CSHH, 1/4-20 x .75, GR5, FT	(2) Per Assembly
4	300-4	4	Washer, Flat, SAE, 1/4	(2) Per Assembly
5	204-4-20-5	4	Nut, Lock, Stover, 1/4-20, GR5	(2) Per Assembly
6	95998936	2	Lock Nut, PTORQ, 3/4-16	(1) Per Assembly
7	301-12	2	Washer, Flat, USS, 3/4	(1) Per Assembly
8	981574	4	Revolving Ball Knob, M12x1.75	(2) Per Assembly
9	200-M12-1.75-8.8	4	Nut, Hex, M12x1.75, C8.8	(2) Per Assembly
10	302-8	4	Washer, Lock, 1/2	(2) Per Assembly
11	810110	4	Push Roller Bearing, ø1.250	(2) Per Assembly
12	20931333	2	Tongued Washer, 1.21 ID x 1.86 OD	(1) Per Assembly
13	95200978	2	Lockwasher	(1) Per Assembly
14	95200879	2	Locknut	(1) Per Assembly
15	1011307	2	Thickness Adjuster Shaft	(1) Per Assembly
16	1011309	2	Key, .25 x .25 x 1.25	(1) Per Assembly
17	21426507	2	Universal Joint	(1) Per Assembly
18	20160644	4	Spirol Pin, ø3/8 x 1.75	(2) Per Assembly
REF	20960332	A/R	Universal Joint Bearing	
19	1006431	2	Adjuster Screw	(1) Per Assembly
20	1006429	2	Adjuster Sleeve w/Ball Joint	(1) Per Assembly

Illustrated Parts List

HD SCREED ENDGATES

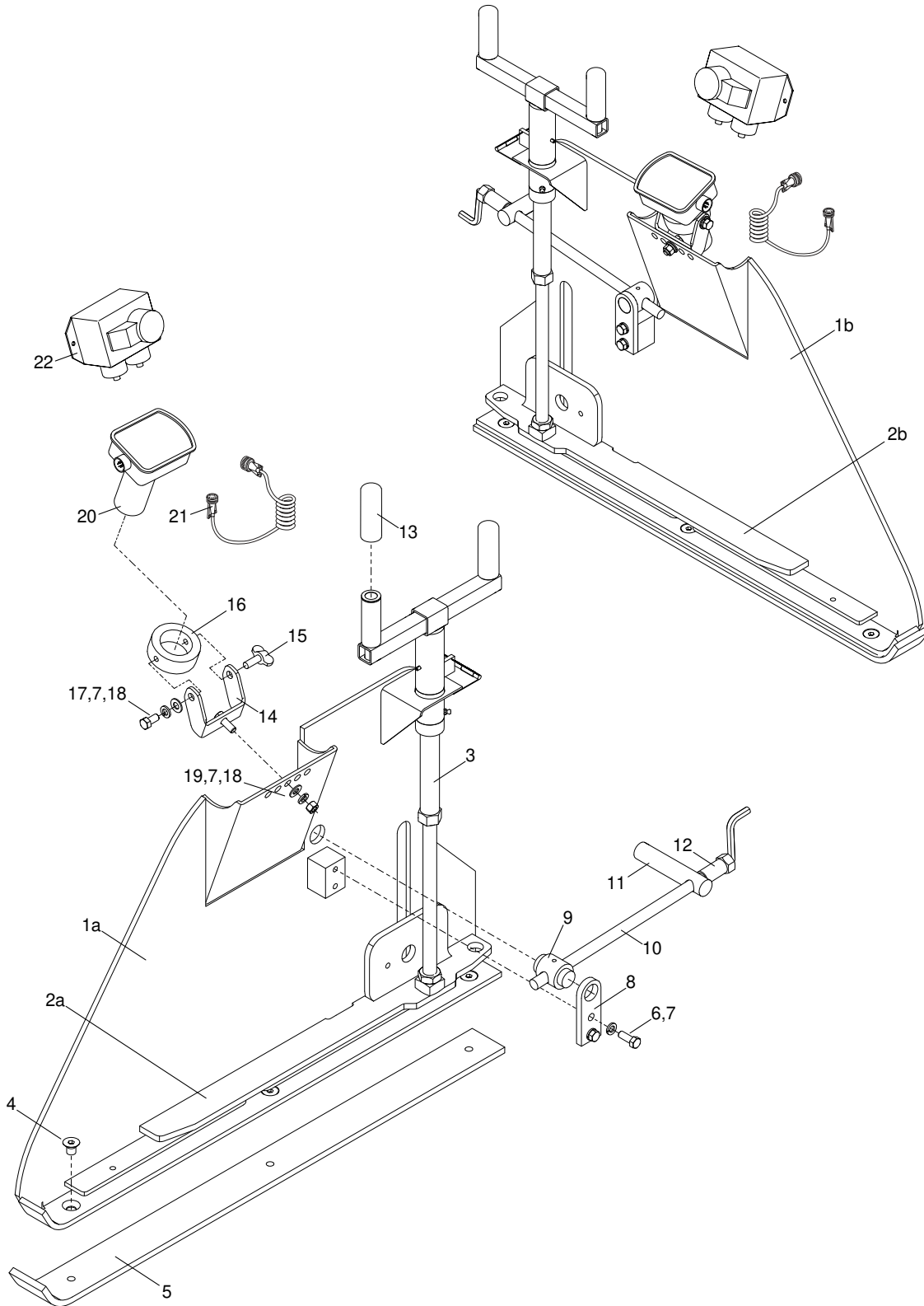

Figure 7-42. HD Screed Endgates

HD Screed Endgates

Item No	Part Number	Qty	Description	Remarks
GRP	1017023		Group - Standard HD Endgates	Does Not Include 20,21
REF	1015990SRV	1	Extension Element Hose & Wiring Kit	
1a	1006443SRV	1	HD Endgate Assembly - Left	Includes Items 2a, 3
1b	1006560SRV		HD Endgate Assembly - Right	Includes Items 2b, 3
2a	1011204	1	Heated Endgate Depth Screw Bracket - Left	
2b	1011203	1	Heated Endgate Depth Screw Bracket - Right	
3	890092SRV	2	Endgate Depth Screw Assembly	(1) Per Assembly
4	105-8-13-12-F	6	CSFHS, 1/2-13 x .75, FT	(3) Per Assembly
5	1006442	2	Endgate Plate	(1) Per Assembly
6	100-6-16-24-5F	4	CSHH, 3/8-16 x 1.50, GR5, FT	(2) Per Assembly
7	302-6	6	Washer, Lock, 3/8	(3) Per Assembly
8	980458	2	Tilt Screw Retainer Bar	(1) Per Assembly
9	980457	2	Tilt Screw Swivel Shaft	(1) Per Assembly
10	890081SRV	2	Tilt Screw	(1) Per Assembly
11	855579	2	CR Shaft, ϕ 1.00 x 4.50	(1) Per Assembly
12	1011235	2	Endgate Adjustment Tube	(1) Per Assembly
13	870276	4	Hand Grip	(2) Per Assembly
14	1015380	2	Sonic Sensor Bracket Weldment	(1) Per Assembly
15	920070	2	Thumb Screw, 3/8-16 x 1.00	(1) Per Assembly
16	1008905	2	Sonic Sensor Mount	(1) Per Assembly
17	100-6-16-12-5F	2	CSHH, 3/8-16 x .75, GR5, FT	(1) Per Assembly
18	300-6	4	Washer, Flat, SAE, 3/8	(2) Per Assembly
19	200-6-16-5	2	Nut, Lock, 3/8-16, GR5	(1) Per Assembly
20	980540	2	Auger Sensor	(1) Per Endgate
21	980550	2	Auger Sensor Cable	(1) Per Endgate
22	982795	2	Remote Pot, Ultrasonic	(1) Per Endgate
23	982796	2	Power Cable, Ultrasonic	Not Shown, (1) Per Endgate

Illustrated Parts List

HD SCREED VIBRATORS AND WALKBOARDS

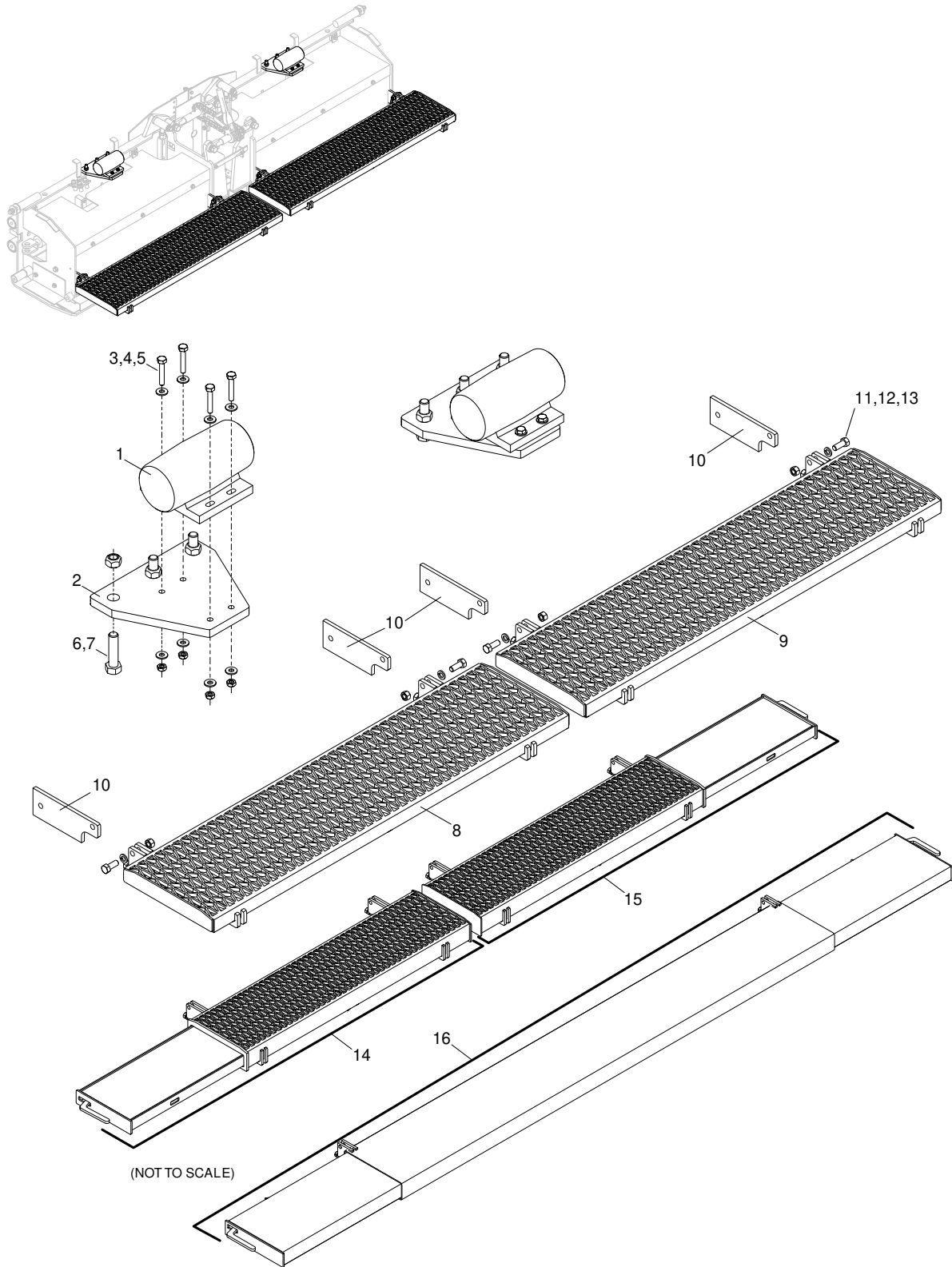

Figure 7-43. HD Screed Vibrators and Walkboards

HD Screenshot Vibrators and Walkboards

Item No	Part Number	Qty	Description	Remarks
GRP	1019720		Group - 815HD Electric Vibrators	Includes Items 1-7
1	1018588	2	Vibrator Motor, 12VDC, DC-60AL	
2	1018801	2	Electric Vibrator Mounting Plate	
3	100-4-20-24-5	8	CSHH, 1/4-20 x 1.50, GR5	
4	300-4	16	Washer, Flat, SAE, 1/4	
5	204-4-20-5	8	Nut, Lock, Stover, 1/4-20	
6	100-8-13-32-5	6	CSHH, 1/2-13 x 2.00, GR5	
7	204-8-13-5	6	Nut, Lock, Stover, 1/2-13	
REF	1019724	1	Electric Vibrator Harness	Not Shown
GRP	1016995		Group - 815HD Gripstrut Walkboard	Includes 8-13
8	1016463	1	Grip Strut Weldment - Left	
9	1016462	1	Grip Strut Weldment - Right	
10	985163	4	Walkboard Hinge Plate	
11	100-8-13-20-5F	4	CSHH, 1/2-13 x 1.25, GR5, FT	
12	302-8	4	Washer, Lock, 1/2	
13	200-8-13-5	4	Nut, Hex, 1/2-13, GR5	
14	1017489	1	Grip Strut Walkboard Assembly w/Extension - Left	Option
15	1017490	1	Grip Strut Walkboard Assembly w/Extension - Right	Option
16	987056SRV	1	Walkboard Assembly w/Extensions	Option

Illustrated Parts List

HD SCREED CITRUS TANK

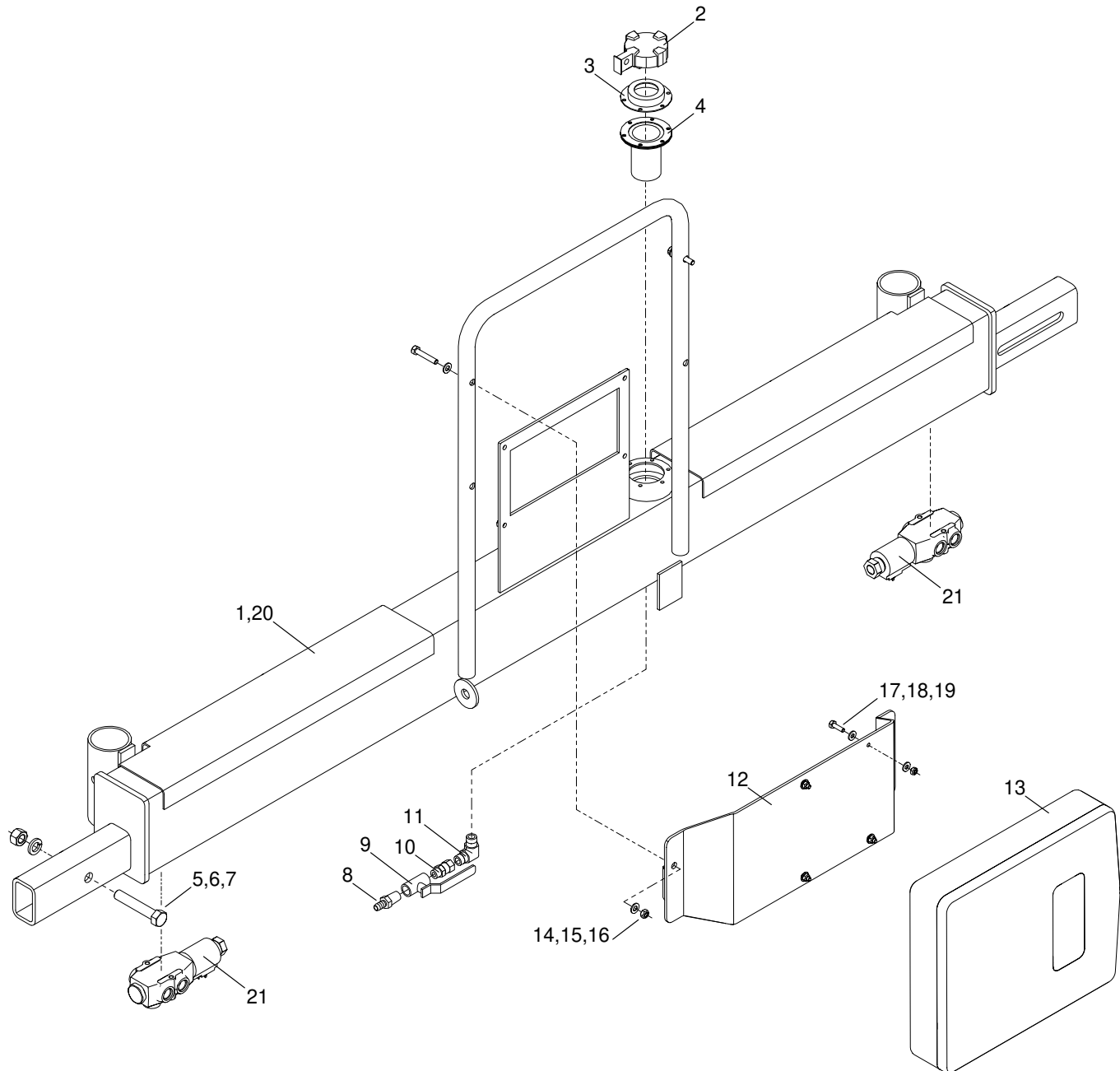

Figure 7-44. HD Screed Citrus Tank

HD Screenshot Citrus Tank

Item No	Part Number	Qty	Description	Remarks
1	1006552SRV	1	Citrus Tank Assembly	Includes Items 2 - 7
2	140030FL	1	Fuel Tank Cap - Lockable	
3	140030FN	1	Fuel Cap Filler Neck	
4	140030GK	1	Fuel Filler Strainer & Gasket Kit	
5	100-10-11-60-5	2	CSHH, 5/8-11 x 3.75, GR5	
6	302-10	2	Washer, Lock, 5/8	
7	200-10-11-5	2	Nut, Hex, 5/8-11, GR5	
8	31959	1	Straight Fitting, 06MP-06HB, Push On	
9	480160	1	Ball Valve - 3/8	
10	6274	1	Straight Fitting, 06MP-06FPX	
11	853211085	1	90° Fitting, 06MP-06MP	
12	1016514	1	Tool Tray Assembly	
13	985234-01	1	Manual Case	
14	100-5-18-28-5	2	CSHH, 5/16-18 x 1.75, GR5	
15	300-5	4	Washer, Flat, SAE, 5/16	
16	204-5-18-5	2	Nut, Lock, Stover, 5/16-18, GR5	
17	100-4-20-14-5	4	CSHH, 1/4-20 x .875, GR5	
18	300-4	8	Washer, Flat, SAE, 1/4	
19	204-4-20-5	4	Nut, Lock, Stover, 1/4-20, GR5	
20	1017163		Group - Citrus Tank for Berm Option	Includes 1 and Mount Plates
21	989656	2	6 Way Electric Selector Valve	Optional w/ Berm Option

Illustrated Parts List

HD SCREED CONTROL ASSEMBLY

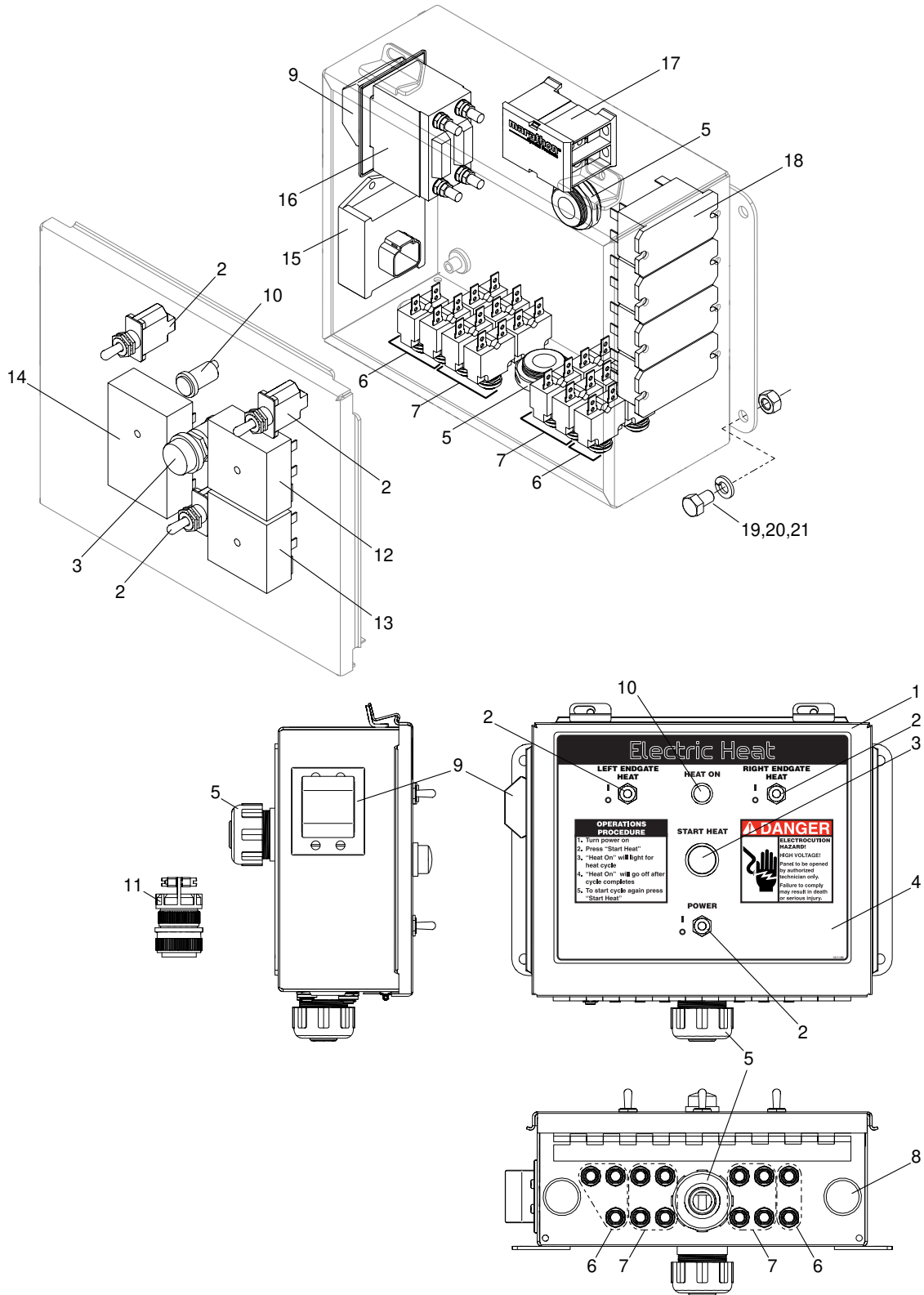

Figure 7-45. HD Screed Control Assembly

HD Screed Control Assembly

Item No	Part Number	Qty	Description	Remarks
REF	1016891	1	Control Box Assembly, 10kW	
1	100804	1	Enclosure, 10 x 8 x 4	
2	851090624	3	Toggle Switch, SPDT, 2-POS	
3	982249	1	Push Button Switch	
4	1011180	1	Decal - Electric Heat	
5	1017228	2	Water Tight Conduit Connector	
6	985140	5	Circuit Breaker, 15A, Pan Mount	
7	1009228	8	Circuit Breaker, 10A	
8	35136-7	2	Plastic Hole Plug, .875, Flush Mount	
9	1016892	1	Circuit Breaker Boot	
10	31983	1	Red Light	
11	985687	1	Amphenol Connector, 06-Pin Male	
12	988230	1	Time Delay Relay, ON, 10A	
13	985142	1	Electric Timer, 06 - 60 MIN	
14	988231	1	Off Delay Timer, 5 Seconds	
15	1017190	1	AC Detector, Generator Control	
16	1016901	1	Circuit Breaker, 40A, Generator Protection	
17	985138-04	1	Terminal Block w/Cover	
18	985141	4	Relay, 12VDC, DSPT, 25A, N/O	
19	100-4-20-12-5F	4	CSHH, 1/4-20 x .75, GR5, FT	
20	302-4	4	Washer, Lock, 1/4	
21	200-4-20-5	4	Nut, Hex, 1/4-20, GR5	
REF	1016723	1	Load Control Box to Bulkhead Harness	Not Shown

Illustrated Parts List

OPTION - HD BERM SCREED OVERVIEW Sloping and Non-Sloping

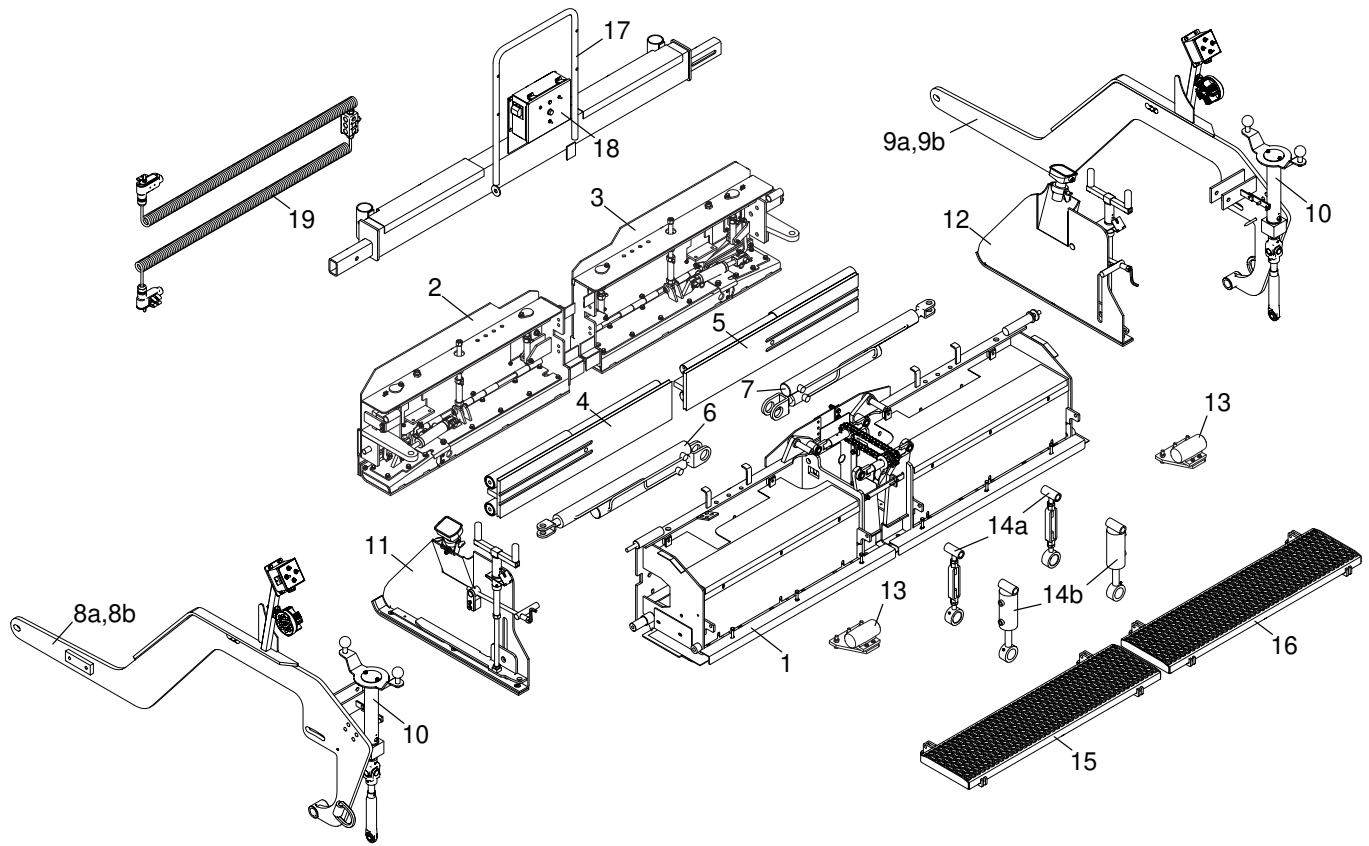

Figure 7-46. Option - HD Berm Screed Overview, Sloping and Non-Sloping

Option - HD Berm Screed Overview, Sloping and Non-Sloping

Item No	Reference Figure	Description	Remarks
1	7-32,7-33	HD Berm Screed Frame Assembly	
2	7-47	HD Berm Screed Extension Assembly - Left	
3	7-48	HD Berm Screed Extension Assembly - Right	
4	7-36	HD Screed Slide Plate Assembly	
5	7-36	HD Screed Slide Plate Assembly	
6	7-33	Hydraulic Cylinder - Left	
7	7-33	Hydraulic Cylinder - Right	
8a	7-37	HD Screed Pull Arm Assembly, 4 Function - Left	
8b	7-39	HD Screed Pull Arm Assembly, 9 Function - Left	
9a	7-38	HD Screed Pull Arm Assembly, 4 Function - Right	
9b	7-40	HD Screed Pull Arm Assembly, 9 Function - Right	
10	7-41	HD Screed Thickness Adjuster - Standard	
11	7-42	HD Screed Endgate Assembly, Standard- Left	
12	7-42	HD Screed Endgate Assembly, Standard - Right	
13	7-43	Electric Screed Vibrator	
14a	7-33	Manual Turnbuckle Assembly	Non-Slope
14b	7-33	Hydraulic Cylinder	Slope
15	7-43	Grip Strut Walkboard Assembly - Left	
16	7-43	Grip Strut Walkboard Assembly - Right	
17	7-44	Citrus Tank Assembly	
18	7-45	Screed Control Assembly	
19	7-49	Berm Remote Assembly	

Illustrated Parts List

Option - HD Berm Screed Extension Assembly - Left (1 of 2)

Item No	Part Number	Qty	Description	Remarks
REF	1015425	1	Berm Extension Assembly - Left	
1	1015426	1	Berm Extension Weldment - Left	
2	1015350	1	Heat Box Hinge Pin	
3	1015428	1	Extension Slide Weldment	
4	1006536	1	Endgate Bracket Plate w/Holes	
5	100-6-24-16-5F	5	CSHH, 3/8-24 x 1.00, GR5, FT	
6	302-6	A/R	Washer, Lock, 3/8	
7	300-6	A/R	Washer, Flat, SAE, 3/8	
8	1016800	1	Endgate Attachment Threaded Rod	
9	202-14-9-5	2	Nut, Jam, 7/8-9, GR5	
10	302-14	1	Washer, Lock, 7/8	
11	1006390	2	Vertical Adjustment Assembly	
12	100-8-13-32-5	4	CSHH, 1/2-13 x 2.00, GR5	
13	302-8	4	Washer, Lock, 1/2	
14	300-8	4	Washer, Flat, SAE, 1/2	
15	118-8-32-3/8x16	2	Shoulder Bolt, ϕ 1/2 x 2L, 3/8-16	
16	204-6-16-5	4	Nut, Lock, Stover, 3/8-16, GR5	
17	1015427	1	Extension Slide Weldment	
18	1015361	1	Berm Height Indicator Bar	
19	1015362	1	Decal - Berm Height Indicator	
20	1015360	1	Berm Height Linkage Plate	
21	100-6-16-20-5	2	CSHH, 3/8-16 x 1.25, GR5	
22	1015349	1	Berm Hydraulic Cylinder	Includes Items 23,24
23	37662	2	Clevis Pin, .750 x 2.00	
24	5928	2	Cotter Pin, .148, #9	
25	1015374	1	Top Asphalt Blocker Plate - Left	
26	301-6	2	Washer, Flat, USS, 3/8	
27	1017683	1	Main Heat Box Assembly - Left	Includes Items 28 - 39
28	1015431	1	Main Heat Box Lid Weldment - Left	
29	100-6-16-12-5F	8	CSHH, 3/8-16 x .75, GR5, FT	
30	1501-6-6	1	90° Female Adapter Union NPTF / NPSM	
31	2405-6-6	2	Connector Adapter, -6 JIC / -6 NPTF	
32	985123	5	Screed Extension Element Clamp	
33	1006033	1	Element Clamp Bar	
34	1015936	1	Heating Element, 1000W/240V, 30"	
35	1015434	1	Berm Lid Heat Box Weldment - Left	
36	1015372	1	Berm Asphalt Blocker Plate - Left	
37	105-6-16-24-F	2	CSFHS, 3/8-16 x 1.50, FT	

7

Illustrated Parts List

OPTION - HD BERM SCREED EXT. ASSEMBLY - LEFT (2 OF 2)

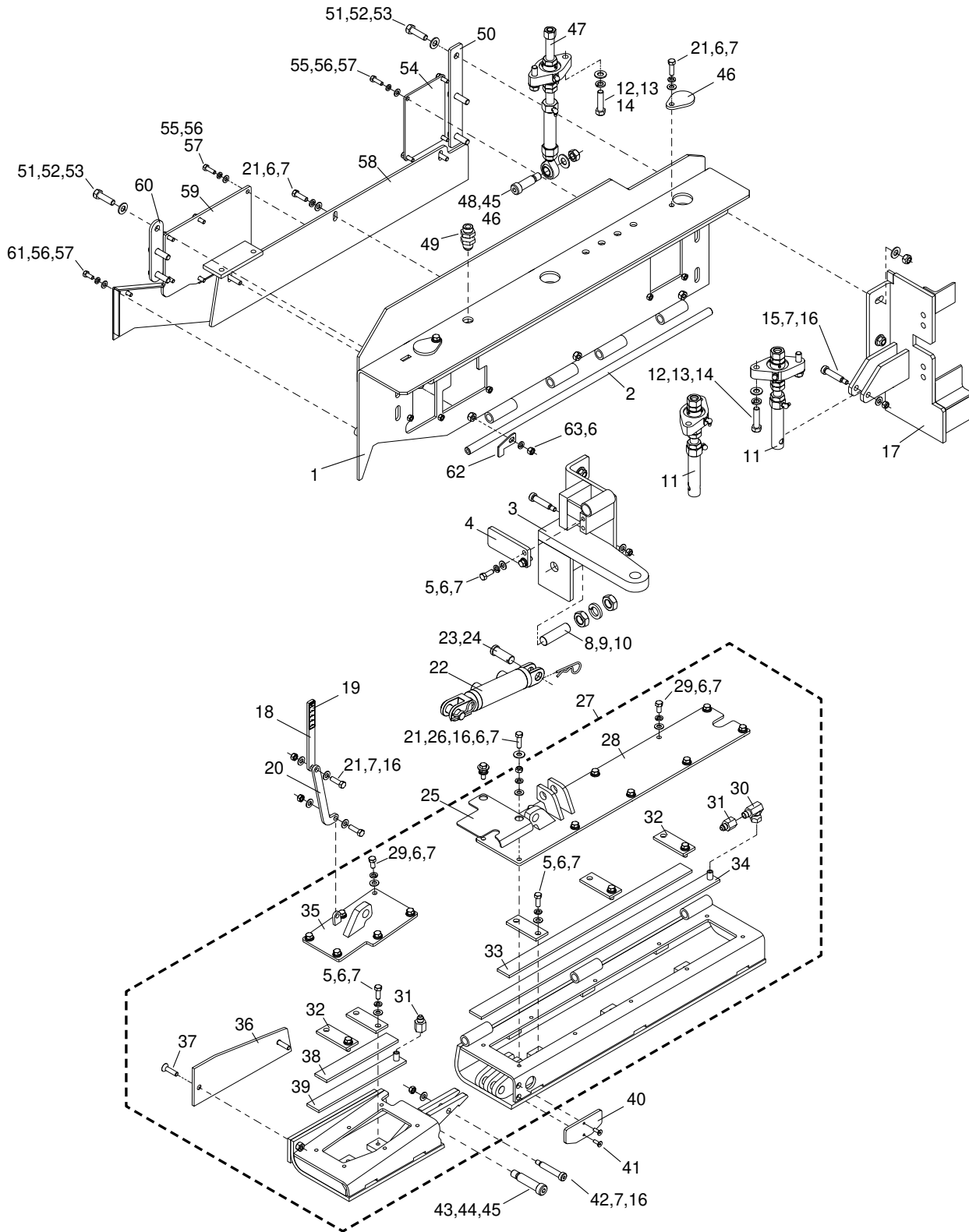

Figure 7-47 Option - HD Berm Screed Extension Assembly - Left (2 of 2)

Option - HD Berm Screed Extension Assembly - Left (2 of 2)

Item No	Part Number	Qty	Description	Remarks
38	1007991	1	Element Backup Plate, 12"	
39	1015918	1	Heating Element, 500W/240V, 11"	
40	1015358	1	Rear Asphalt Blocker Plate	
41	105-4-20-12-F	2	CSFHS, 1/4-20 x .75, FT	
42	118-8-40-3/8x16	1	Shoulder Bolt, ϕ 1/2 x 2.5L, 3/8-16	
43	118-12-40-5/8x11	1	Shoulder Bolt, ϕ 3/4 x 2.5L, 5/8-11	
44	300-10	1	Washer, Flat, 5/8	
45	204-10-11-5	1	Nut, Lock, Stover, 5/8-11, GR5	
46	1006439	2	Extension Adjuster Cover	
47	1006401	1	AOA Adjuster Assembly	
48	118-12-28-5/8x11	1	Shoulder Bolt, ϕ 3/4 x 1.75L, 5/8-11	
49	1015947	1	Screed Bulkhead Union Adapter	
50	1006395	1	Vertical Lift Bar	
51	100-8-13-28-5	6	CSHH, 1/2-13 x 1.75, GR5	
52	300-8	12	Washer, Flat, SAE, 1/2	
53	204-8-13-5	6	Nut, Lock, Stover, 1/2-13, GR5	
54	1006398	1	Extension Access Cover Plate	
55	100-5-18-16-5	10	CSHH, 5/16-18 x 1.00, GR5	
56	302-5	12	Washer, Lock, 5/16	
57	300-5	12	Washer, Flat, SAE, 5/16	
58	1015351	1	Main Asphalt Blocker Plate	
59	1015435SRV	1	Vibrator Mount Weldment	
60	1015356	1	Adjuster Mount Plate	
61	100-5-18-12-5F	2	CSHH, 5/16-18 x .75, GR5, FT	
62	1015357	1	Hinge Rod Retainer Tab	
63	200-6-16-5	1	Nut, Hex, 3/8-16, GR5	

Illustrated Parts List

OPTION - HD BERM SCREED EXT. ASSEMBLY - RIGHT (1 OF 2)

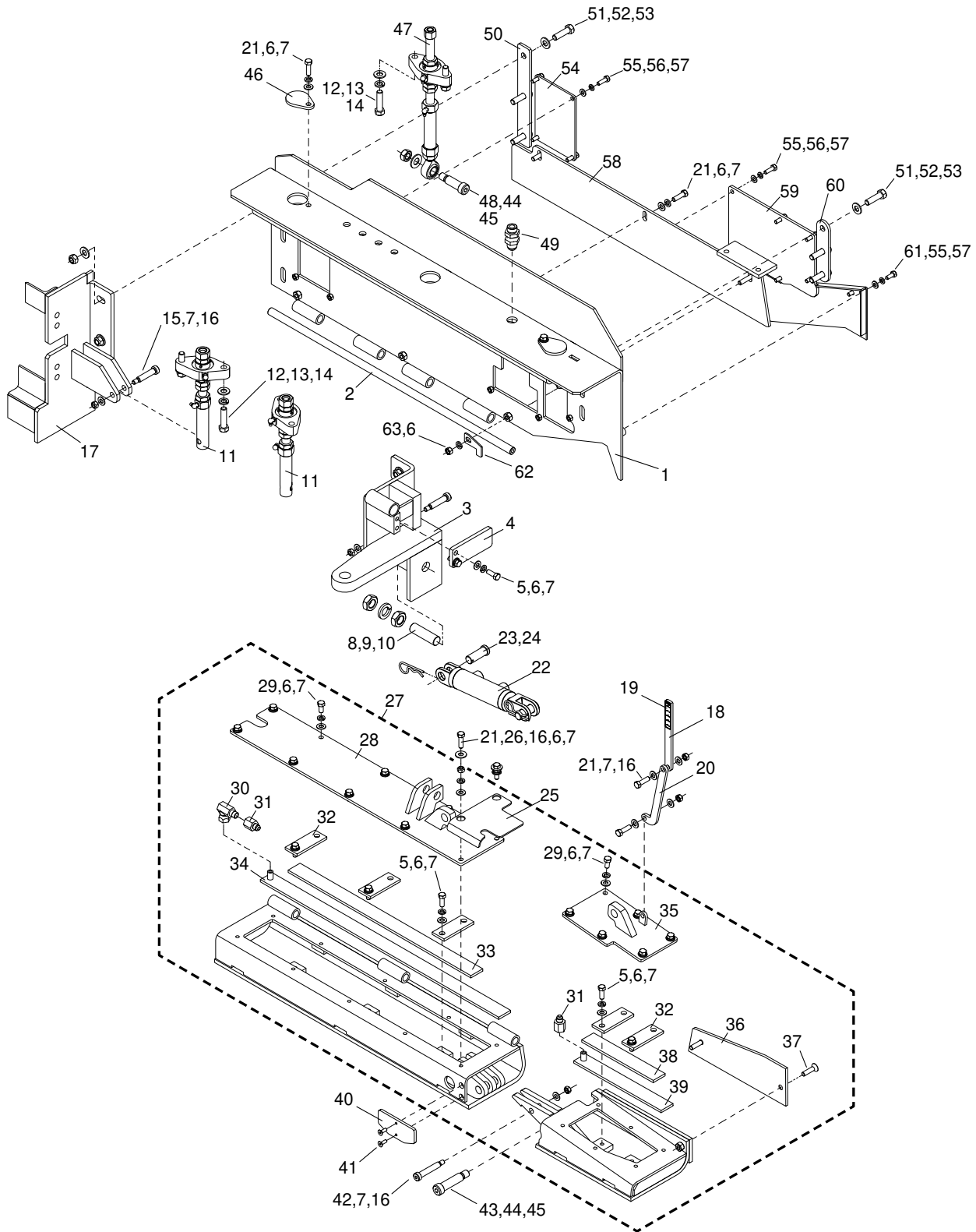

Figure 7-48. Option - HD Berm Screed Extension Assembly - Right (1 of 2)

Option - HD Berm Screed Extension Assembly - Right (1 of 2)

Item No	Part Number	Qty	Description	Remarks
REF	1015413	1	Berm Extension Assembly - Right	
1	1015414	1	Berm Extension Weldment - Right	
2	1015350	1	Heat Box Hinge Pin	
3	1015416	1	Extension Slide Weldment	
4	1006536	1	Endgate Bracket Plate w/Holes	
5	100-6-24-16-5F	5	CSHH, 3/8-24 x 1.00, GR5, FT	
6	302-6	A/R	Washer, Lock, 3/8	
7	300-6	A/R	Washer, Flat, SAE, 3/8	
8	1016800	1	Endgate Attachment Threaded Rod	
9	202-14-9-5	2	Nut, Jam, 7/8-9, GR5	
10	302-14	1	Washer, Lock, 7/8	
11	1006390	2	Vertical Adjustment Assembly	
12	100-8-13-32-5	4	CSHH, 1/2-13 x 2.00, GR5	
13	302-8	4	Washer, Lock, 1/2	
14	300-8	4	Washer, Flat, SAE, 1/2	
15	118-8-32-3/8x16	2	Shoulder Bolt, ϕ 1/2 x 2L, 3/8-16	
16	204-6-16-5	4	Nut, Lock, Stover, 3/8-16, GR5	
17	1015415	1	Extension Slide Weldment	
18	1015361	1	Berm Height Indicator Bar	
19	1015362	1	Decal - Berm Height Indicator	
20	1015360	1	Berm Height Linkage Plate	
21	100-6-16-20-5	2	CSHH, 3/8-16 x 1.25, GR5	
22	1015349	1	Berm Hydraulic Cylinder	Includes Items 23,24
23	37662	2	Clevis Pin, .750 x 2.00	
24	5928	2	Cotter Pin, .148, #9	
25	1015359	1	Top Asphalt Blocker Plate - Right	
26	301-6	2	Washer, Flat, USS, 3/8	
27	1017682	1	Main Heat Box Assembly - Right	Includes Items 28 - 39
28	1015419	1	Main Heat Box Lid Weldment - Right	
29	100-6-16-12-5F	8	CSHH, 3/8-16 x .75, GR5, FT	
30	1501-6-6	1	90° Female Adapter Union NPTF / NPSM	
31	2405-6-6	2	Connector Adapter, -6 JIC / -6 NPTF	
32	985123	5	Screed Extension Element Clamp	
33	1006033	1	Element Clamp Bar	
34	1015936	1	Heating Element, 1000W/240V, 30"	
35	1015422	1	Berm Lid Heat Box Weldment - Right	
36	1015348	1	Berm Asphalt Blocker Plate - Right	
37	105-6-16-24-F	2	CSFHS, 3/8-16 x 1.50, FT	

Illustrated Parts List

OPTION - HD BERM SCREED EXT. ASSEMBLY - RIGHT (2 OF 2)

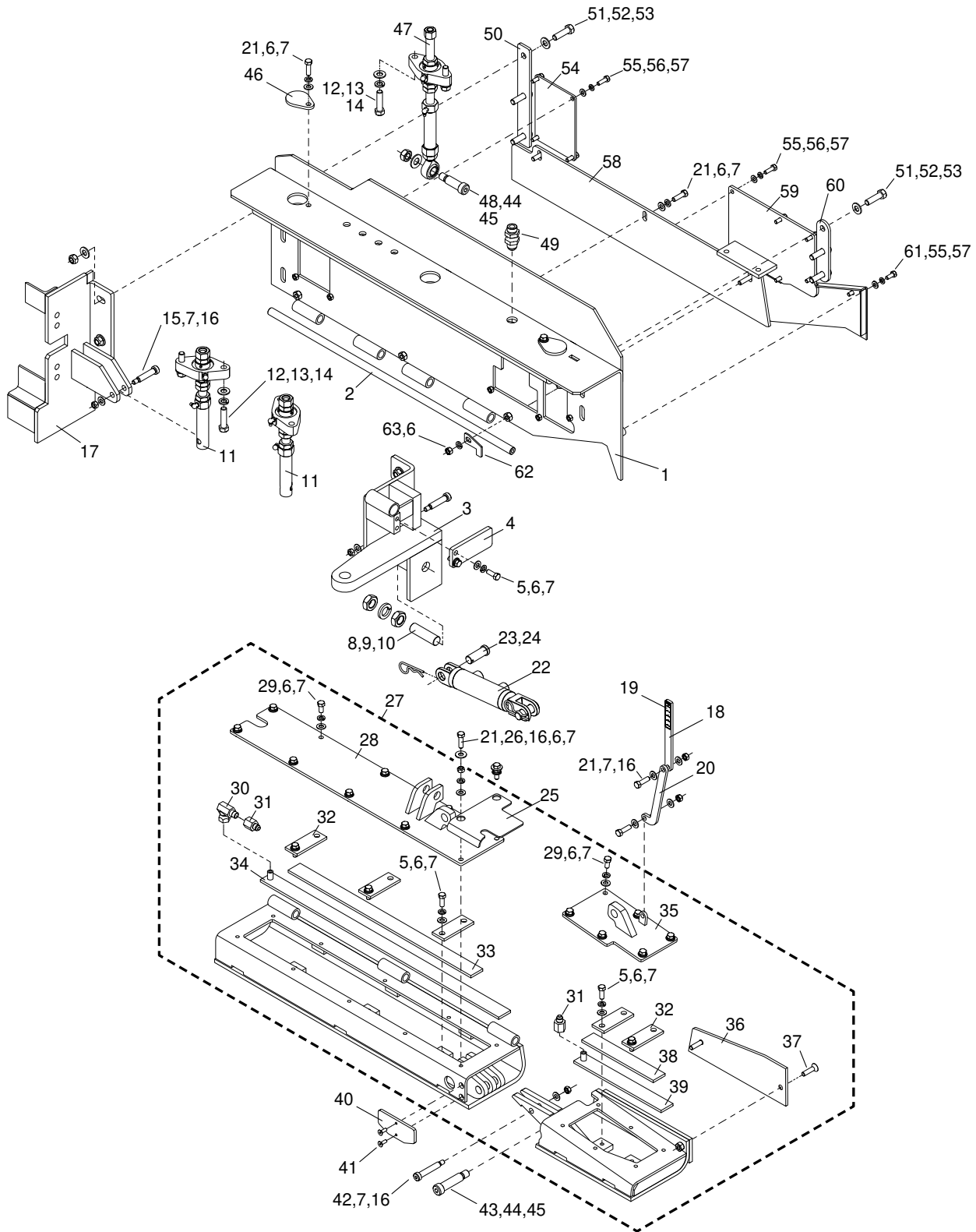

Figure 7-48. Option - HD Berm Screed Extension Assembly - Right (2 of 2)

Option - HD Berm Screed Extension Assembly - Right (2 of 2)

Item No	Part Number	Qty	Description	Remarks
38	1007991	1	Element Backup Plate, 12"	
39	1015918	1	Heating Element, 500W/240V, 11"	
40	1015358	1	Rear Asphalt Blocker Plate	
41	105-4-20-12-F	2	CSFHS, 1/4-20 x .75, FT	
42	118-8-40-3/8x16	1	Shoulder Bolt, \varnothing 1/2 x 2.5L, 3/8-16	
43	118-12-40-5/8x11	1	Shoulder Bolt, \varnothing 3/4 x 2.5L, 5/8-11	
44	300-10	1	Washer, Flat, 5/8	
45	204-10-11-5	1	Nut, Lock, Stover, 5/8-11, GR5	
46	1006439	2	Extension Adjuster Cover	
47	1006401	1	AOA Adjuster Assembly	
48	118-12-28-5/8x11	1	Shoulder Bolt, \varnothing 3/4 x 1.75L, 5/8-11	
49	1015947	1	Screed Bulkhead Union Adapter	
50	1006395	1	Vertical Lift Bar	
51	100-8-13-28-5	6	CSHH, 1/2-13 x 1.75, GR5	
52	300-8	12	Washer, Flat, SAE, 1/2	
53	204-8-13-5	6	Nut, Lock, Stover, 1/2-13, GR5	
54	1006398	1	Extension Access Cover Plate	
55	100-5-18-16-5	10	CSHH, 5/16-18 x 1.00, GR5	
56	302-5	12	Washer, Lock, 5/16	
57	300-5	12	Washer, Flat, SAE, 5/16	
58	1015351	1	Main Asphalt Blocker Plate	
59	1015423SRV	1	Vibrator Mount Weldment	
60	1015356	1	Adjuster Mount Plate	
61	100-5-18-12-5F	2	CSHH, 5/16-18 x .75, GR5, FT	
62	1015357	1	Hinge Rod Retainer Tab	
63	200-6-16-5	1	Nut, Hex, 3/8-16, GR5	

Illustrated Parts List

OPTION - HD BERM SCREED REMOTE ASSEMBLY

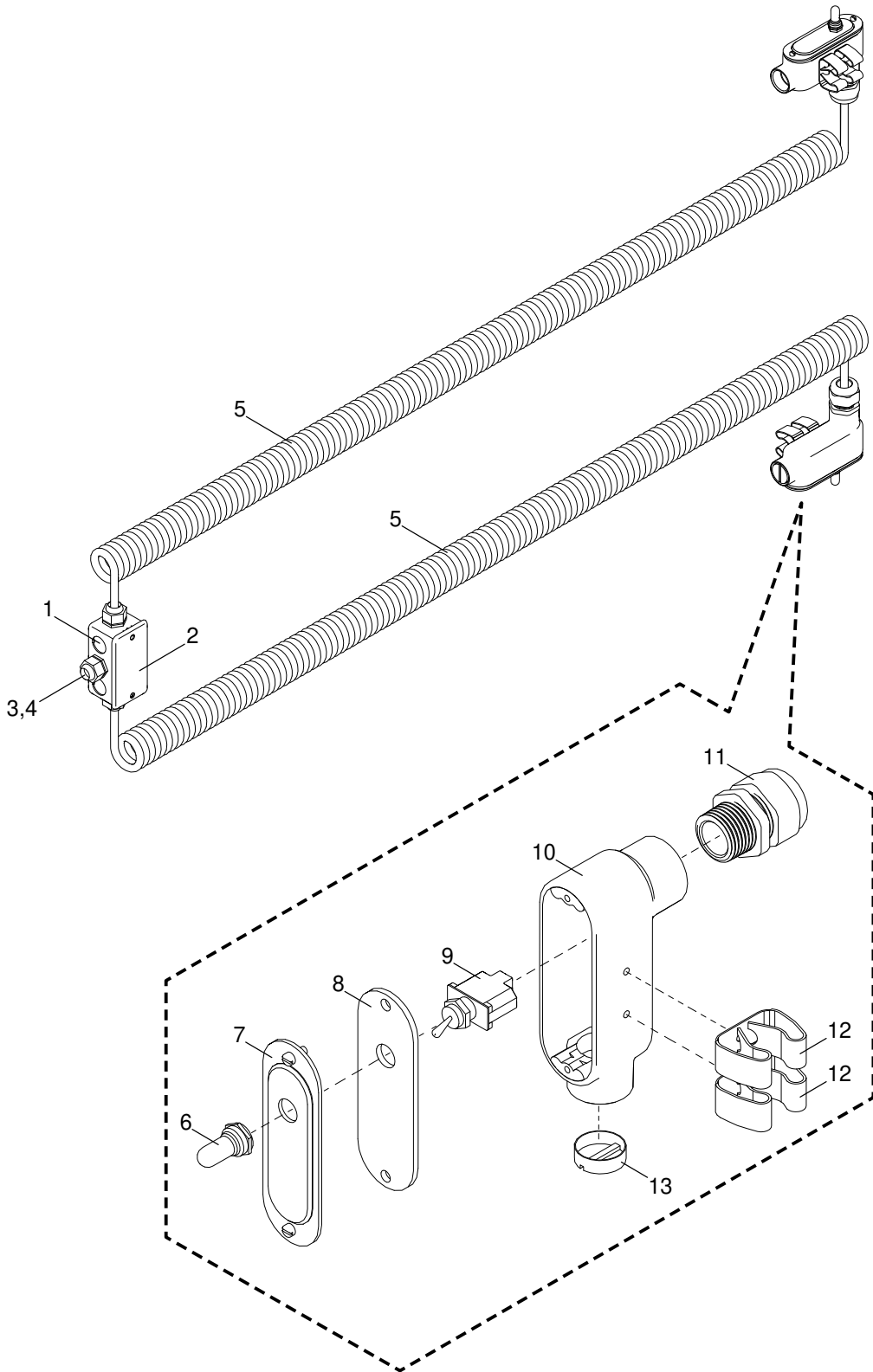

Figure 7-49. Option - HD Berm Screed Remote Assembly

Option - HD Berm Screed Remote Assembly

Item No	Part Number	Qty	Description	Remarks
REF	1017180	1	Selector Valve Berm Remote Assembly	
1	920238-6	1	Junction Box	
2	920238-7	1	Junction Box Blank Cover	
3	3200DI	3	Water Tight Connector, 1/2 x 1/2 MPT	
4	LN1010	3	Conduit Lock Nut, 1/2	
5	900082	2	12V Curly Cord	
6	851440	2	Toggle Switch Weather Boot	
7	920238-3	2	Condulet Cover, 3/4	
8	920238-4	2	Condulet Box Gasket, 3/4	
9	851391	2	Toggle Switch, SPST, 2-POS	
10	920238-2	2	Aluminum Condulet, 3/4	
11	3400DI	2	Water Tight Connector, 3/4 x 3/4 MPT	
12	920238-1	4	Gripper Clamp	
13	920238-5	2	Aluminum Condulet Plug, 3/4	

Illustrated Parts List

OPTION - HD 3:1 DEPTH SCREWS (1 OF 2)

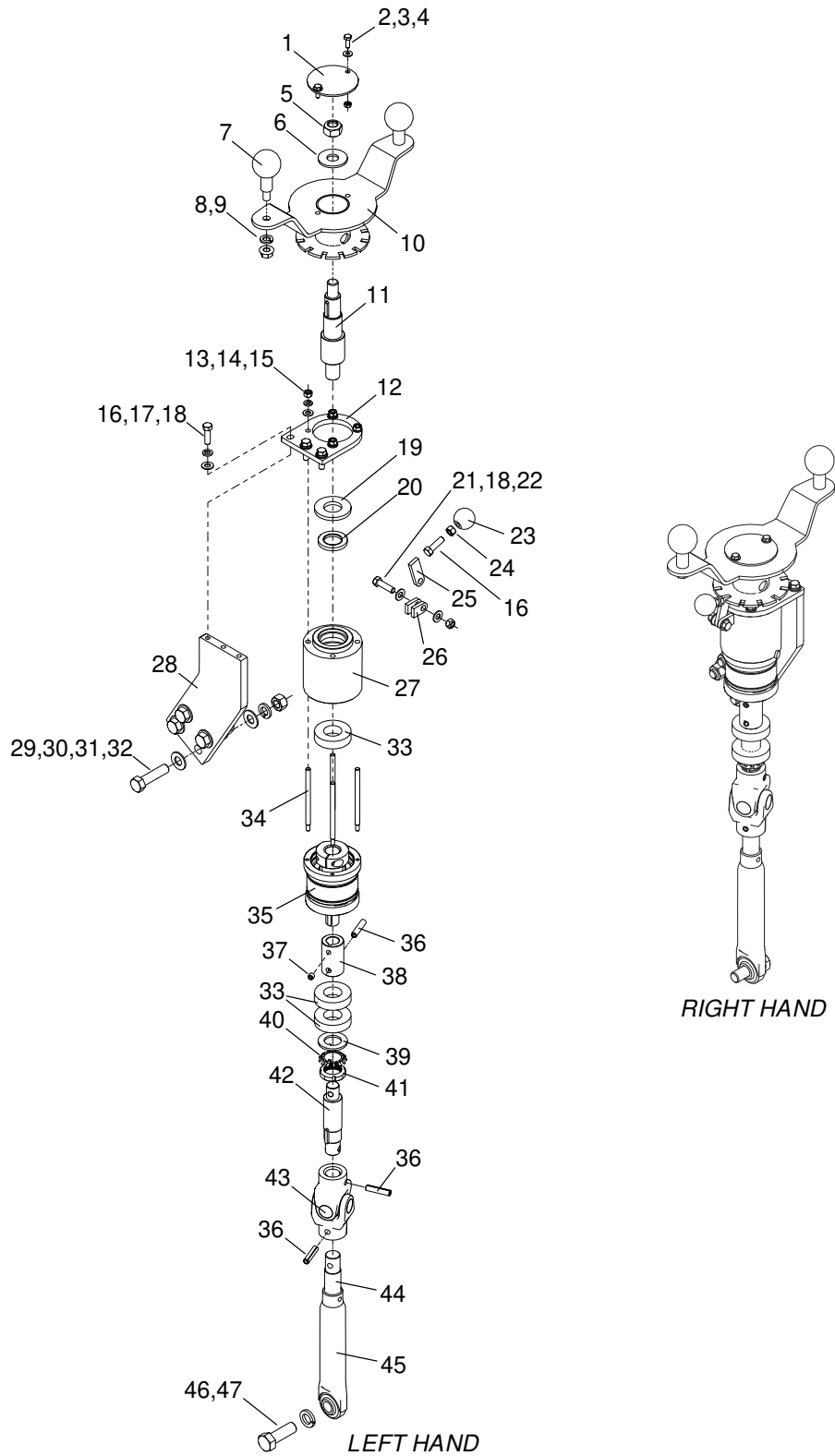

Figure 7-50. Option - HD 3:1 Depth Screws (1 of 2)

Option - HD 3:1 Depth Screws (1 of 2)

Item No	Part Number	Qty	Description	Remarks
GRP	1015263SRV		Option - Depth Screws, 3:1 Adjusters	
REF	1014929	1	Planetary Drive Flight Screw Assembly - Left	
REF	1014928	1	Planetary Drive Flight Screw Assembly - Right	
1	1006434	2	Adjuster Screw Cap	(1) Per Assembly
2	100-4-20-12-5F	4	CSHH, 1/4-20 x .75, GR5, FT	(2) Per Assembly
3	300-4	4	Washer, Flat, SAE, 1/4	(2) Per Assembly
4	204-4-20-5	4	Nut, Lock, Stover, 1/4-20, GR5	(2) Per Assembly
5	205-12-10-5	2	Nut, Lock, Nylon, 3/4-10, GR5	(1) Per Assembly
6	301-12	2	Washer, Flat, USS, 3/4	(1) Per Assembly
7	981574	4	Revolving Ball Knob, M12x1.75	(2) Per Assembly
8	200-M12-1.75-8.8	4	Nut, Hex, M12x1.75, C8.8	(2) Per Assembly
9	302-8	4	Washer, Lock, 1/2	(2) Per Assembly
10	1014115	2	Thickness Weldment	(1) Per Assembly
11	1014925	2	Upper Planetary Drive Shaft	(1) Per Assembly
12	1014922	2	Top Planetary Mounting Plate	(1) Per Assembly
13	200-5-18-5	8	Nut, Hex, 5/16-18, GR5	(4) Per Assembly
14	302-5	8	Washer, Lock, 5/16	(4) Per Assembly
15	300-5	8	Washer, Flat, SAE, 5/16	(4) Per Assembly
16	100-6-16-20-5	8	CSHH, 3/8-16 x 1.25, GR5	(4) Per Assembly
17	302-6	6	Washer, Lock, 3/8	(3) Per Assembly
18	300-6	10	Washer, Flat, SAE, 3/8	(5) Per Assembly
19	1015285	2	Nylon Dust Cover	(1) Per Assembly
20	1014930	2	Shaft Seal, 1.25 ID x 2.00 OD	(1) Per Assembly
21	100-6-16-22-5	2	CSHH, 3/8-16 x 1.375, GR5	(1) Per Assembly
22	204-6-16-5	2	Nut, Lock, Stover, 3/8-16, GR5	(1) Per Assembly
23	851156	2	Round Ball Knob, 3/8-16 x 1.375	(1) Per Assembly
24	200-6-16-5	2	Nut, Hex, 3/8-16, GR5	(1) Per Assembly
25	981487	2	1/4 x 3/4 FB x 2-1/4 w/Hole	(1) Per Assembly
26	1014068	4	Flight Screw Lock Mounting Tab	(2) Per Assembly
27	1014924	2	Planetary Adapter Tube	(1) Per Assembly
28	1014923	2	Side Planetary Mount Plate	(1) Per Assembly
29	100-10-11-40-5	8	CSHH, 5/8-11 x 2.50, GR5	(4) Per Assembly
30	300-10	16	Washer, Flat, SAE, 5/8	(8) Per Assembly
31	302-10	8	Washer, Lock, 5/8	(4) Per Assembly
32	200-10-11-5	8	Nut, Lock, 5/8-11, GR5	(4) Per Assembly
33	810110	6	Push Roller Bearing, 1.250	(3) Per Assembly
34	1014931	8	Planetary Threaded Rod	(4) Per Assembly
35	1014921	2	Planetary Drive Reduction Box	(1) Per Assembly

Illustrated Parts List

OPTION - HD 3:1 DEPTH SCREWS (2 OF 2)

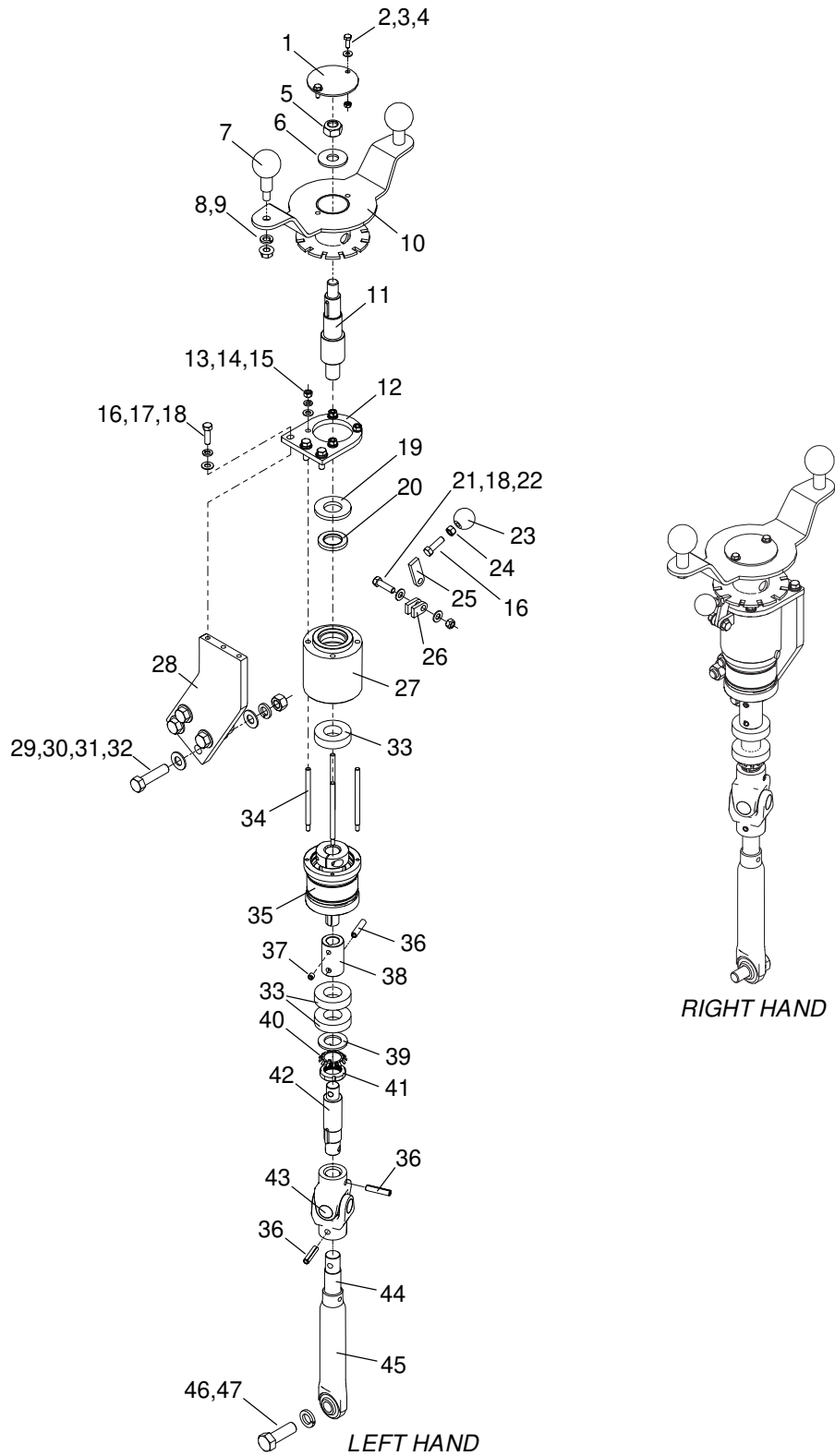

Figure 7-50. Option - HD 3:1 Depth Screws (2 of 2)

Option - HD 3:1 Depth Screws (2 of 2)

Item No	Part Number	Qty	Description	Remarks
36	20160644	6	Spirol Pin, ø3/8 x 1.750	(3) Per Assembly
37	113-6-16-6	2	Set Screw, HSKT, Cup, 3/8-16 x .375	(1) Per Assembly
38	1014927	2	Planetary Box Coupler	(1) Per Assembly
39	20931333	2	Tongued Washer, 1.21 ID x 1.86 OD	(1) Per Assembly
40	95200978	2	Lockwasher	(1) Per Assembly
41	95200879	2	Locknut	(1) Per Assembly
42	1014926	2	Lower Planetary Drive Shaft	(1) Per Assembly
43	21426507	2	Universal Joint	(1) Per Assembly
REF	20960332	A/R	Universal Joint Bearing	As Needed
44	1006431	2	Adjuster Screw	(1) Per Assembly
45	1006429	2	Adjuster Sleeve w/Ball Joint	(1) Per Assembly
46	100-12-10-36-5	2	CSHH, 3/4-10 x 2.25, GR5	(1) Per Assembly
47	302-12	2	Washer, Lock, 3/4	(1) Per Assembly

Illustrated Parts List

OPTION - HD SCREED HEATED ENDGATES

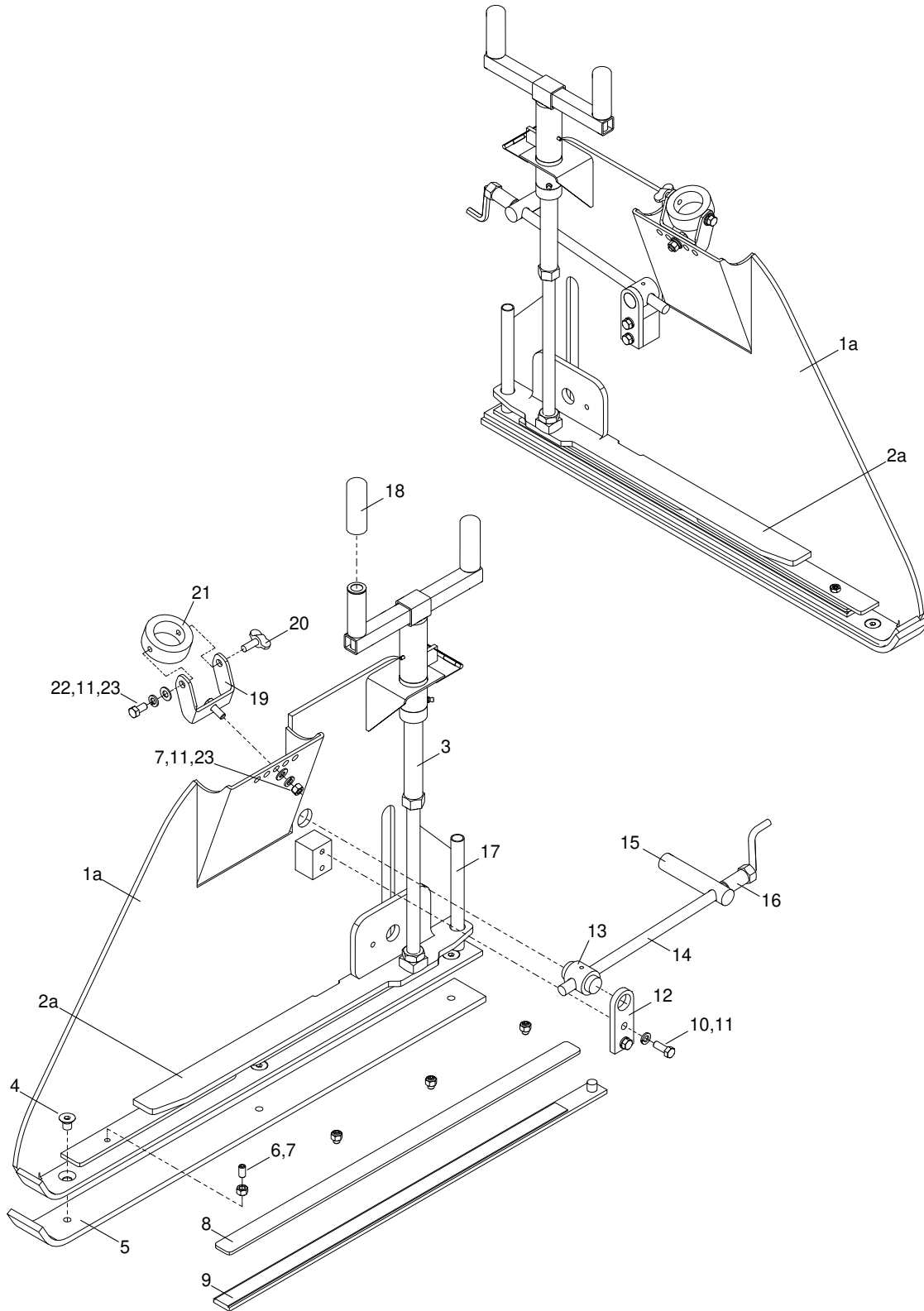

Figure 7-51. Option - HD Screed Heated Endgates

Option - HD Screed Heated Endgates

Item No	Part Number	Qty	Description	Remarks
GRP	1017024		Group - Heated HD Endgates	
REF	1015990SRV		Extension Element Hose & Wiring Kit	
REF	1011143SRV	1	Heated HD Endgate Assembly - Left	Includes Items 1a, 4 - 23
REF	1011144SRV	1	Heated HD Endgate Assembly - Right	Includes Items 1b, 4 - 23
1a	1006443SRV	1	HD Endgate Assembly - Left	Includes Items 2a, 3
1b	1006560SRV		HD Endgate Assembly - Right	Includes Items 2b, 3
2a	1011204	1	Heated Endgate Depth Screw Bracket - Left	
2b	1011203	1	Heated Endgate Depth Screw Bracket - Right	
3	890092	2	Endgate Depth Screw Assembly	(1) Per Assembly
4	105-8-13-12-F	6	CSFHS, 1/2-13 x .75, FT	(3) Per Assembly
5	1006442	2	Endgate Plate	(1) Per Assembly
6	113-6-16-12	8	Set Screw, HSKT, Cup, 3/8-16 x .75	(4) Per Assembly
7	200-6-16-5	10	Nut, Hex, 3/8-16, GR5	(4) Per Assembly
8	1011155	2	Element Backup Bar	(1) Per Assembly
9	1011158	2	Heating Element, 500W/220V, 30"	(1) Per Assembly
10	100-6-16-24-5F	4	CSHH, 3/8-16 x 1.50, GR5, FT	(2) Per Assembly
11	302-6	6	Washer, Lock, 3/8	(3) Per Assembly
12	980458	2	Tilt Screw Retainer Bar	(1) Per Assembly
13	980457	2	Tilt Screw Swivel Shaft	(1) Per Assembly
14	890081SRV	2	Tilt Screw	(1) Per Assembly
15	855579	2	CR Shaft, ø1.00 x 4.50	(1) Per Assembly
16	1011235	2	Endgate Adjustment Tube	(1) Per Assembly
17	1011491	2	Element Wire Routing Tube	(1) Per Assembly
18	870276	4	Hand Grip	(2) Per Assembly
19	1015380	2	Sonic Sensor Bracket Weldment	(1) Per Assembly
20	920070	2	Thumb Screw, 3/8-16 x 1.00	(1) Per Assembly
21	1008905	2	Sonic Sensor Mount	(1) Per Assembly
22	100-6-16-12-5F	2	CSHH, 3/8-16 x .75, GR5, FT	(1) Per Assembly
23	300-6	4	Washer, Flat, SAE, 3/8	(2) Per Assembly

Illustrated Parts List

OPTION - HD SCREED HEATED SAFETY EDGE ENDGATES

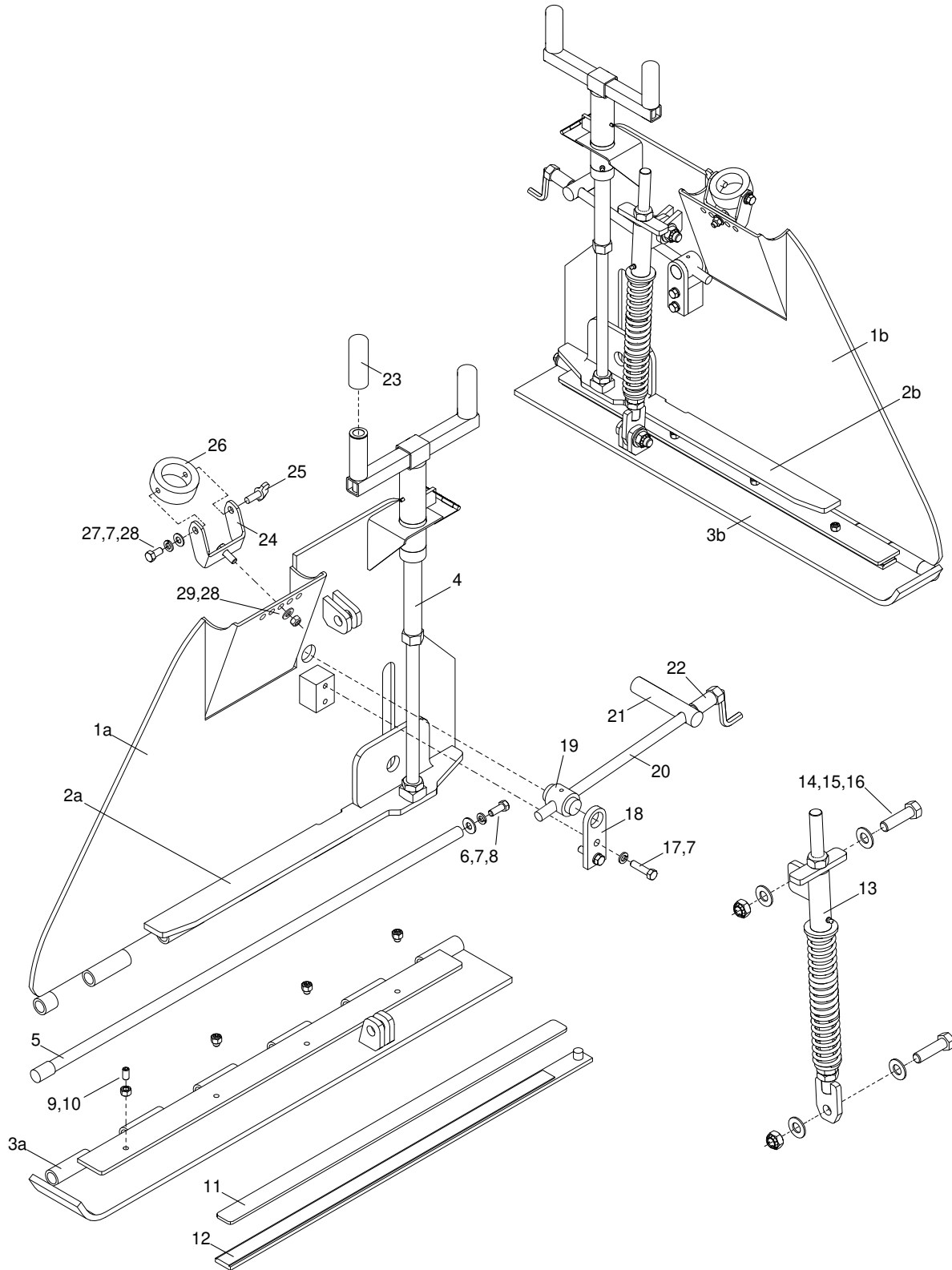

Figure 7-52. Option - HD Screed Heated Safety Edge Endgates

Option - HD Screed Heated Safety Edge Endgates

Item No	Part Number	Qty	Description	Remarks
GRP	1017025		Group - HD Heated Endgates and Safety Edge	
REF	1015990SRV	1	Extension Element Hose & Wiring Kit	
REF	1011187SRV	1	Heated Edge HD Endgate Assembly - Left	Includes Items 1a,3a,5 - 29
REF	1011156SRV	1	Heated Edge HD Endgate Assembly - Right	Includes Items 1b,3b,5 - 29
1a	1011189	1	Heated Safety Edge Main Plate Weldment - Left	Includes Items 2a, 4
1b	1011161	1	Heated Safety Edge Main Plate Weldment - Right	Includes Items 2b, 4
2a	1011206	1	Safety Edge Depth Screw Bracket - Left	
2b	1011205	1	Safety Edge Depth Screw Bracket - Right	
3a	1011190	1	Heated Safety Edge HD Skid Weldment - Left	
3b	1011165	1	Heated Safety Edge HD Skid Weldment - Right	
4	890092SRV	2	Depth Screw Endgate Assembly	(1) Per Assembly
5	1011195	2	Heated Safety Edge HD Hinge Pin Weldment	(1) Per Assembly
6	100-6-16-16-5F	2	CSHH, 3/8-16 x 1.00, GR5, FT	(1) Per Assembly
7	302-6	6	Washer, Lock, 3/8	(3) Per Assembly
8	301-6	2	Washer, Flat, USS, 3/8	(1) Per Assembly
9	113-6-16-12	8	Set Screw, HSKT, Cup, 3/8-16 x .75	(4) Per Assembly
10	200-6-16-5	8	Nut, Hex, 3/8-16, GR5	(4) Per Assembly
11	1011155	2	Element Backup Bar	(1) Per Assembly
12	1011158	2	Heating Element, 500W/220V, 30"	(1) Per Assembly
13	1011453	2	Safety Edge Spring Mechanism	(1) Per Assembly
14	100-10-11-36-5	4	CSHH, 5/8-11 x 2.25, GR5	(2) Per Assembly
15	300-10	8	Washer, Flat, SAE, 5/8	(4) Per Assembly
16	217-10-11	4	Nut, Lock, Flexloc, 5/8-11, Full, LT	(2) Per Assembly
17	100-6-16-24-5F	4	CSHH, 3/8-16 x 1.50, GR5, FT	(2) Per Assembly
18	980458	2	Tilt Screw Retainer Bar	(1) Per Assembly
19	980457	2	Tilt Screw Swivel Shaft	(1) Per Assembly
20	890081SRV	2	Tilt Screw	(1) Per Assembly
21	855579	2	CR Shaft, ø1.00 x 4.50	(1) Per Assembly
22	1011235	2	Endgate Adjustment Tube	(1) Per Assembly
23	870276	4	Hand Grip	(2) Per Assembly
24	1015380	2	Sonic Sensor Bracket Weldment	(1) Per Assembly
25	920070	2	Thumb Screw, 3/8-16 x 1.00	(1) Per Assembly
26	1008905	2	Sonic Sensor Mount	(1) Per Assembly
27	100-6-16-12-5F	2	CSHH, 3/8-16 x .75, GR5, FT	(1) Per Assembly
28	300-6	4	Washer, Flat, SAE, 3/8	(2) Per Assembly
29	204-6-16-5	2	Nut, Lock, Stover, 3/8-16, GR5	(1) Per Assembly

Illustrated Parts List

OPTION - HD MISCELLANEOUS OPTIONS

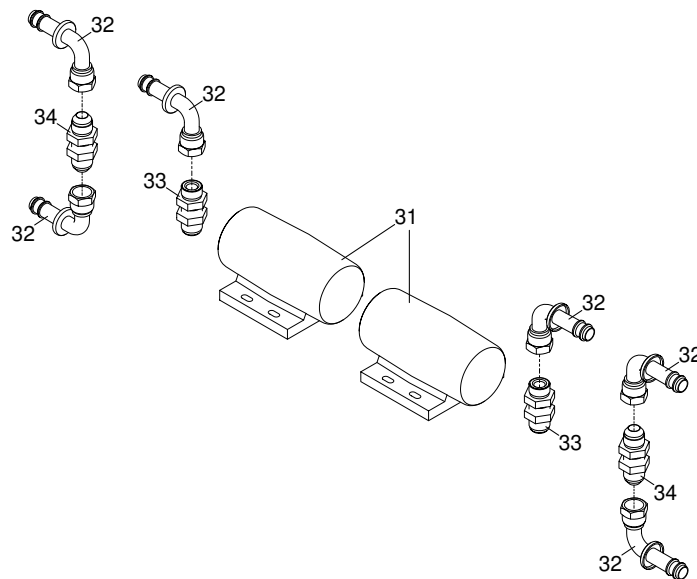
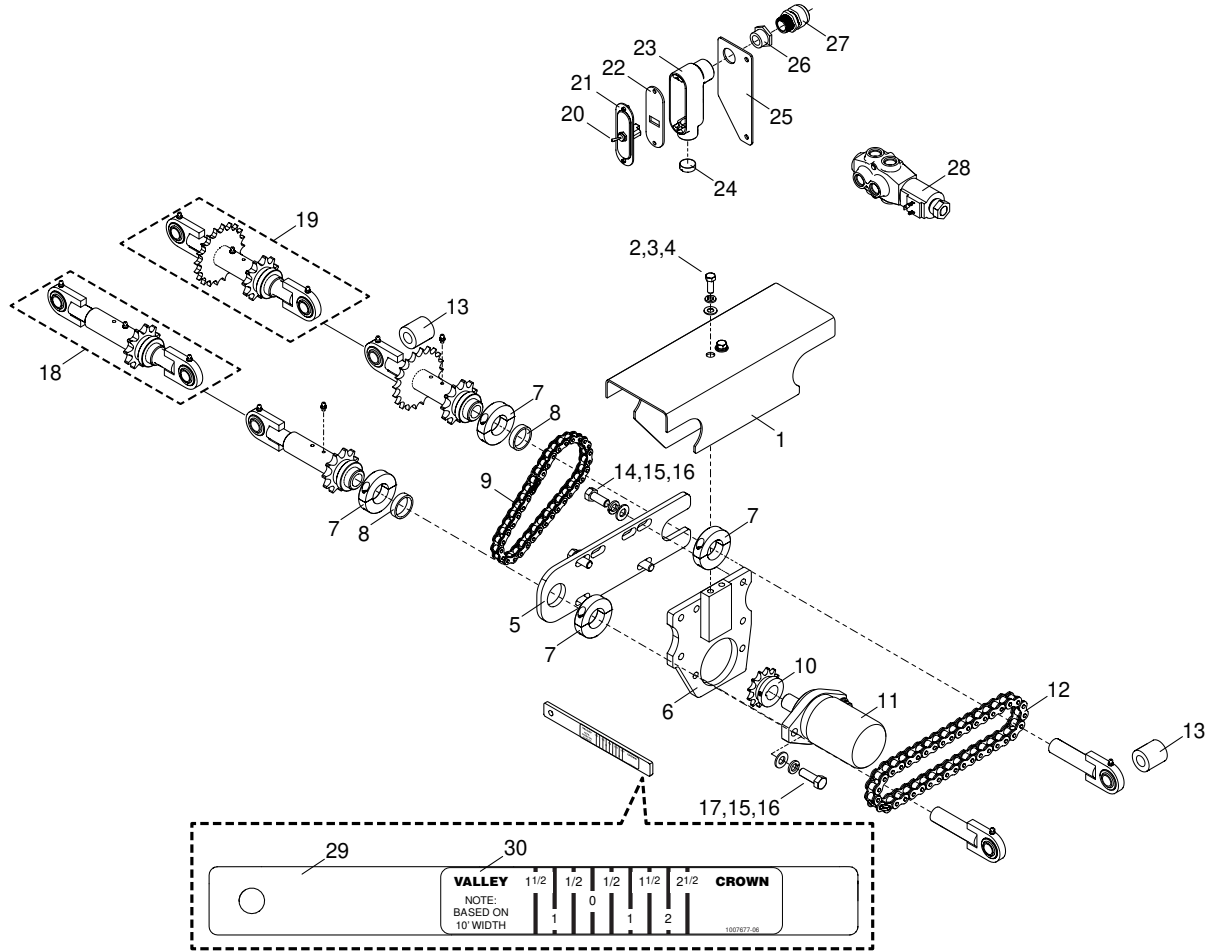

Figure 7-53. Option - HD Miscellaneous Options

Option - HD Miscellaneous Options

Item No	Part Number	Qty	Description	Remarks
GRP	1017001		Group - Power Crown w/Slope Option	
1	1008168	1	Power Crown Cover	
2	100-6-16-16-5F	2	CSHH, 3/8-16 x 1.00, GR5, FT	
3	302-6	2	Lock, Washer, 3/8	
4	300-6	2	Flat, Washer, SAE, 3/8	
5	1008600	1	Power Crown Adjuster Plate	
6	1008667	1	Power Crown Center Weldment	
7	1000798	4	Power Crown Locking Collar	
8	1000960	2	Power Crown Composite Bushing	
9	1000958	1	Roller Chain, 50x18	
10	1000799	1	Roller Chain Sprocket, #50	
11	986640	1	Hydraulic Motor	
12	1008047	1	Roller Chain, 60H x 39 Pitches	
13	1006419	2	Power Crown Mounting Spacer	
14	100-8-13-16-5F	4	CSHH, 1/2-13 x 1.00, GR5, FT	
15	302-8	6	Washer, Lock, 1/2	
16	300-8	6	Washer, Flat, SAE, 1/2	
17	100-8-13-24-5	2	CSHH, 1/2-13 x 1.50, GR5	
18	1009614	1	Crown & Valley Turnbuckle Assembly	
19	1009609	1	Crown & Valley Rear Assembly	
20	851391	1	Toggle Switch, SPST, 2-POS	
21	920238-3	1	Condulet Cover, 3/4"	
22	920238-4	1	Condulet Box Gasket, 3/4"	
23	920238-2	1	Condulet, Aluminum, 3/4"	
24	920238-5	1	Condulet Aluminum Plug, 3/4"	
25	1008683	1	Power Crown Switch Mounting Plate	
26	99985	1	Pipe Bushing, 12MP-08FP, Steel	
27	3400DI	1	Water Tight Connector, 3/4" x 3/4"	
28	989656	1	Electric Selector Valve, 6-Way	
29	1007232	1	Power Crown Gauge Bar	
30	1007677-06	1	Decal - Power Crown	
REF	1015123	1	Power Crown Hose Kit	Not Shown
GRP	1008965SRV		Group - Screed Extension Vibrators	
31	1018588	2	Vibrator Motor, 12VDC, DC-60AL	
32	33982-10-10	6	Fitting, Push Lok, 90°, Short, -10 FJX/-10 Hose	
33	1015947	2	Swivel Bulkhead Union Adapter	
34	2700-10-10-LN	2	Bulkhead Union Adapter, -10 JIC/-10 JIC	
REF	1017742	1	Extension Electric Vibrator Harness	Not Shown

Illustrated Parts List

OPTION - LEGEND NON-SLOPING SCREED OVERVIEW

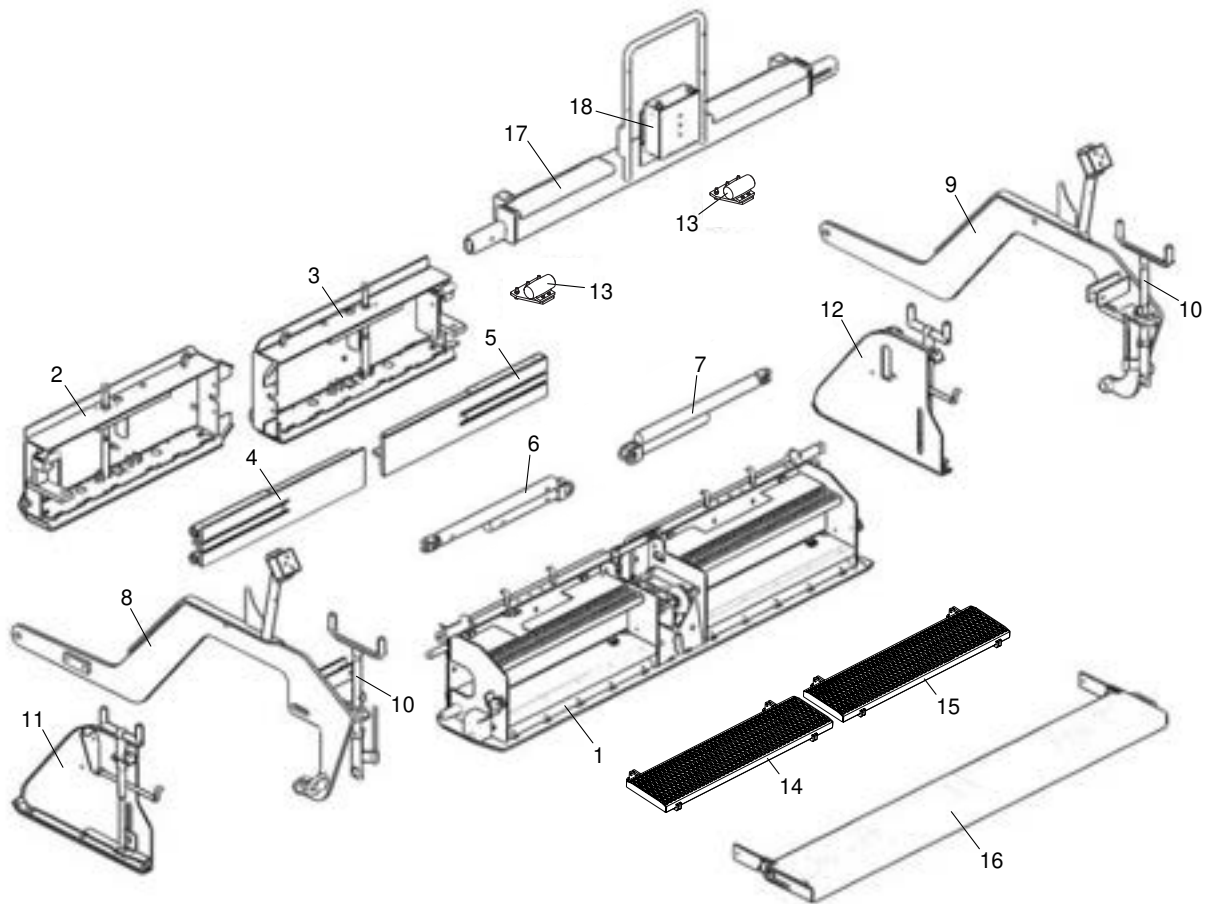

Figure 7-54. Option - Legend Non-Sloping Screed Overview

Option - Legend Non-Sloping Screed Overview

Item No	Reference Figure	Description	Remarks
1	7-56	Legend Screed Frame Assembly w/o Slope	
2	7-58	Screed Extension Assembly - Left	
3	7-59	Screed Extension Assembly - Right	
4	7-62	Screed Slide Plate Assembly	
5	7-62	Screed Slide Plate Assembly	
6	7-56	Hydraulic Cylinder - Left	
7	7-56	Hydraulic Cylinder - Right	
8	7-63	Screed Pull Arm Assembly - Left	
9	7-64	Screed Pull Arm Assembly - Right	
10	7-63,7-64	Screed Thickness Adjuster - Standard	
11	7-65	Screed Endgate Assembly, Standard- Left	
12	7-66	Screed Endgate Assembly, Standard - Right	
13	7-43	Electric Screed Vibrator	
14	7-43	Grip Strut Walkboard Assembly - Left	
15	7-43	Grip Strut Walkboard Assembly - Right	
16	7-43	Walkboard Assembly - Option	
17	7-67	Citrus Tank Assembly	
18	7-45	Screed Control Assembly	

Illustrated Parts List

OPTION - LEGEND SLOPING SCREED OVERVIEW

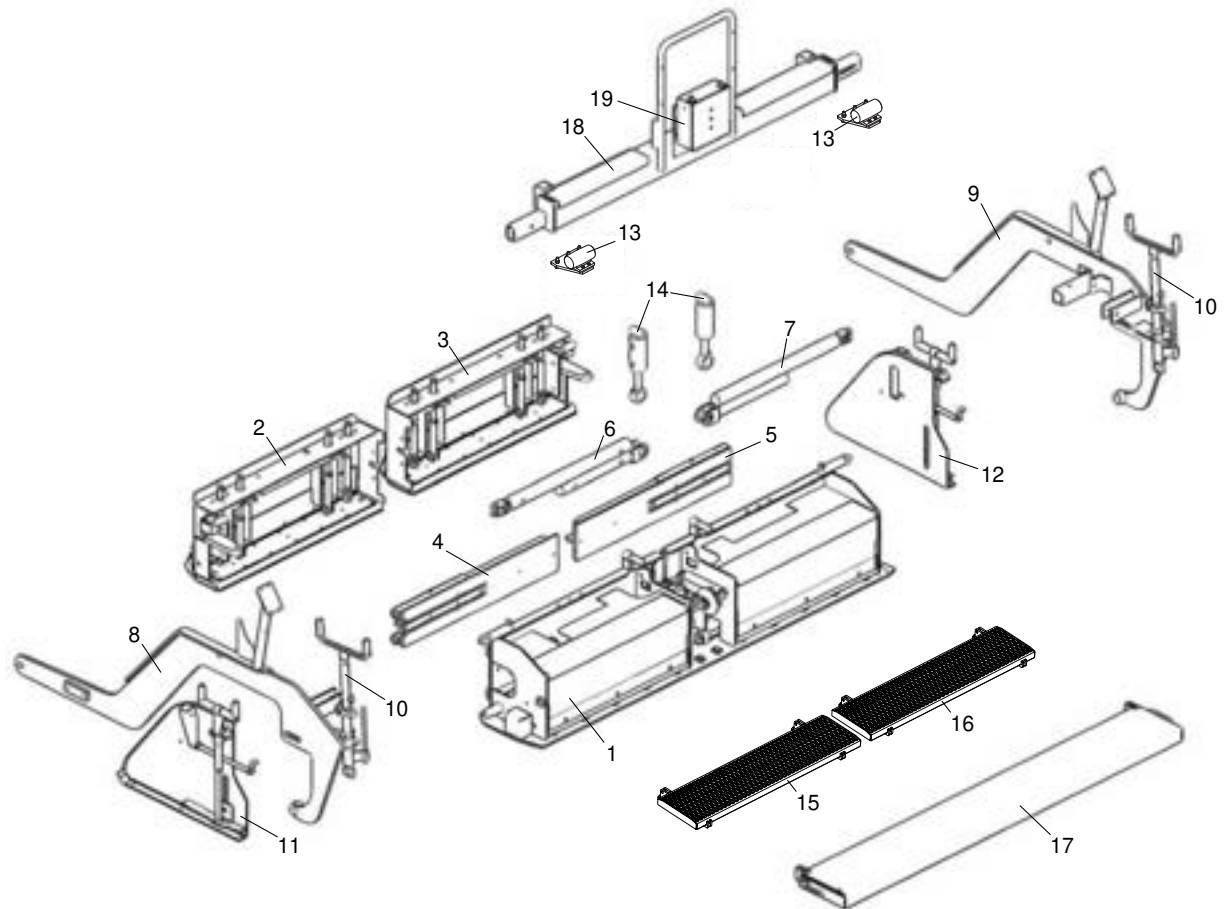

Figure 7-55. Option - Legend Sloping Screed Overview

Option - Legend Sloping Screed Overview

Item No	Reference Figure	Description	Remarks
1	7-57	Legend Screed Frame Assembly w/Slope	
2	7-58	Screed Extension Assembly - Left	
3	7-59	Screed Extension Assembly - Right	
4	7-62	Screed Slide Plate Assembly	
5	7-62	Screed Slide Plate Assembly	
6	7-57	Hydraulic Cylinder - Left	
7	7-57	Hydraulic Cylinder - Right	
8	7-63	Screed Pull Arm Assembly - Left	
9	7-64	Screed Pull Arm Assembly - Right	
10	7-63,7-64	Screed Thickness Adjuster - Standard	
11	7-65	Screed Endgate Assembly, Standard- Left	
12	7-66	Screed Endgate Assembly, Standard - Right	
13	7-43	Electric Screed Vibrator	
14	7-57	Hydraulic Cylinder	
15	7-43	Grip Strut Walkboard Assembly - Left	
16	7-43	Grip Strut Walkboard Assembly - Right	
17	7-43	Walkboard Assembly - Option	
18	7-67	Citrus Tank Assembly	
19	7-45	Screed Control Assembly	

Illustrated Parts List

OPTION - LEGEND NON-SLOPING SCREED FRAME ASSEMBLY

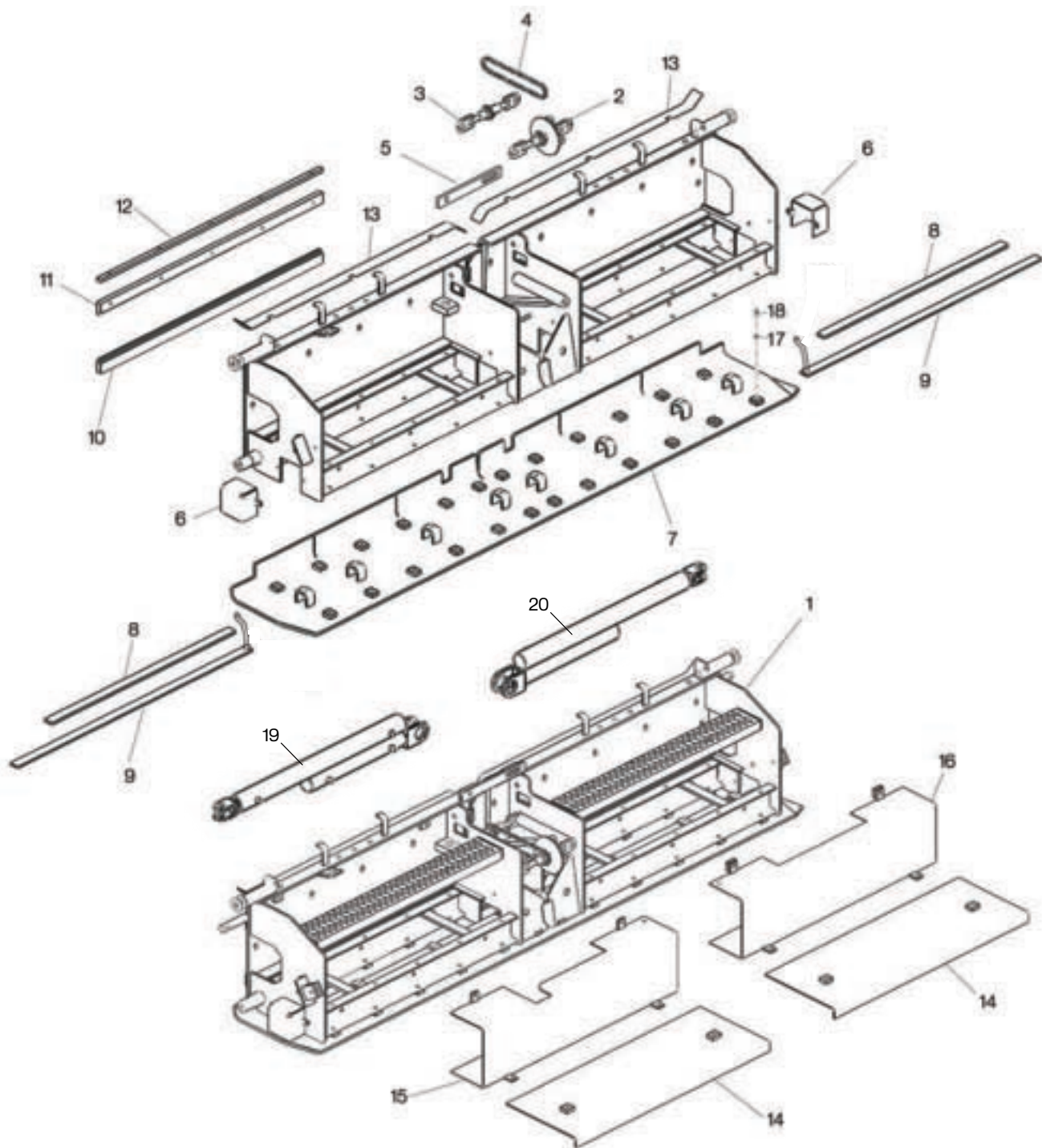

Figure 7-56. Option - Legend Non-Sloping Screed Frame Assembly

Option - Legend Non-Sloping Screed Frame Assembly

Item No	Part Number	Qty	Description	Remarks
1	989377SRV	1	Legend Screed Base - Standard	Includes item 14, 15, 16
2	870182	1	Crown & Valley Assembly - Rear	
3	870172	1	Crown & Valley Assembly - Front	
4	870190	1	Roller Chain, 40 x 52 Pitch	
5	988376	1	Crown & Valley Locking Bar	
6	985124	2	Screed Base Element Cover	
7	987216SRV	1	Wear Plate Assembly	
8	985121	2	Bar, .375 x 1.50 x 42	
9	987886SRV	2	Heater Element, 1750W/220V, 46"	
10	855783	1	Screed Extension Bottom Rail	
11	855784	1	Screed Extension Top Rail	
12	988556	1	Screed Slide Bar Jack	
13	855562	1	Bar, .125 x 2.00 x 44.50, Notches	RH or LH
14	851201SRV	2	Screed Plate Access Cover	
15	851204SRV	1	Screed Extension Cylinder Cover - Left	
16	851203SRV	1	Screed Extension Cylinder Cover - Right	
17	302-6	24	Washer, Lock, 3/8	
18	100-6-24-16-5F	24	CSHH, 3/8-24 x 1.00, GR5, FT	
19	851191	1	Hydraulic Cylinder, 2.00 x 12.00/30.00 x 1.25 - Left	
20	851192	1	Hydraulic Cylinder, 2.00 x 12.00/30.00 x 1.25 - Right	
REF	851191-01	A/R	Hydraulic Cylinder Seal Kit	

Illustrated Parts List

OPTION - LEGEND SLOPING SCREED FRAME ASSEMBLY

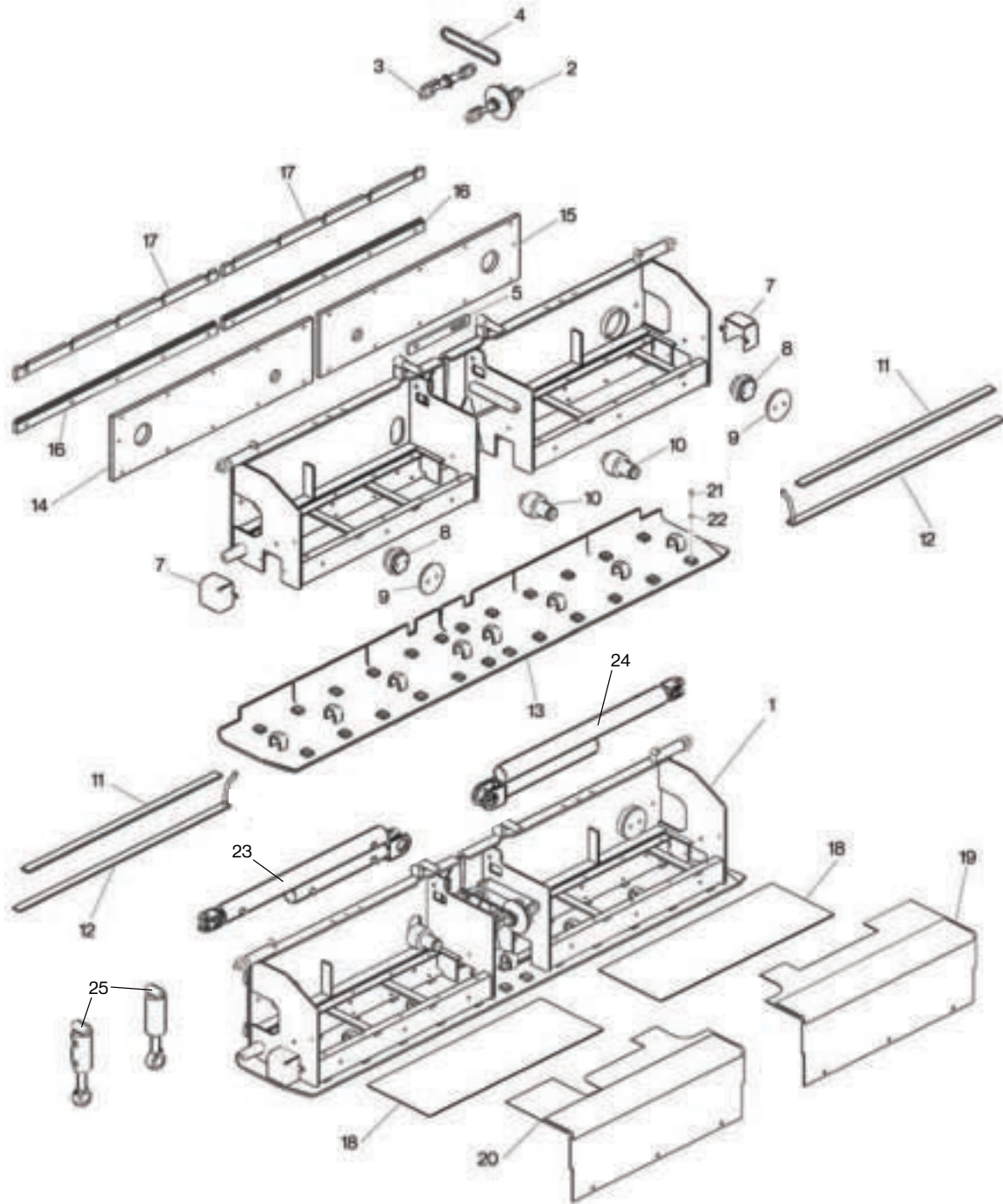

Figure 7-57. Option - Legend Sloping Screed Frame Assembly

Option - Legend Sloping Screed Frame Assembly

Item No	Part Number	Qty	Description	Remarks
1	985547SRV	1	Legend Screed Base w/Slope	Includes item 18, 19, 20
2	870182	1	Crown & Valley Assembly - Rear	
3	870172	1	Crown & Valley Assembly - Front	
4	870190	1	Chain, Roller, 40 x 52 Pitch	
5	988376	1	Crown And Valley Locking Bar	
7	985124	2	Screed Base Element Cover	
8	981659	2	Pivot Bar	
9	981711	2	Pivot Cover Plate	
10	981661	2	Cylinder Mount Pin	
11	985121	2	Bar, .375 x 1.50 x 42	
12	987886SRV	2	Heater Element, 1750W/220V, 46.5"	
13	987216SRV	1	Wear Plate Assembly	
14	981656	1	Rail Mount Plate	
15	981656	1	Rail Mount Plate	
16	981658	2	Bottom Rail Bar	
17	981657	2	Top Rail Bar	
18	985149	2	Screed Lid Cover	
19	985147	1	Screed Cover Plate - Right	
20	985148	1	Screed Cover Plate - Left	
21	100-6-24-16-5F	24	CSHH, 3/8-24 x 1.00, GR5, FT	
22	302-6	24	Washer, Lock, 3/8	
23	851191	1	Hydraulic Cylinder, 2.00 x 12.00/30.00 x 1.25 - Left	
24	851192	1	Hydraulic Cylinder, 2.00 x 12.00/30.00 x 1.25 - Right	
REF	851191-01	A/R	Hydraulic Cylinder Seal Kit	
25	983421	2	Hydraulic Cylinder, 2.75 x 2.00 x 1.125	

Illustrated Parts List

OPTION - LEGEND SCREED EXTENSION SINGLE ADJUST - LEFT

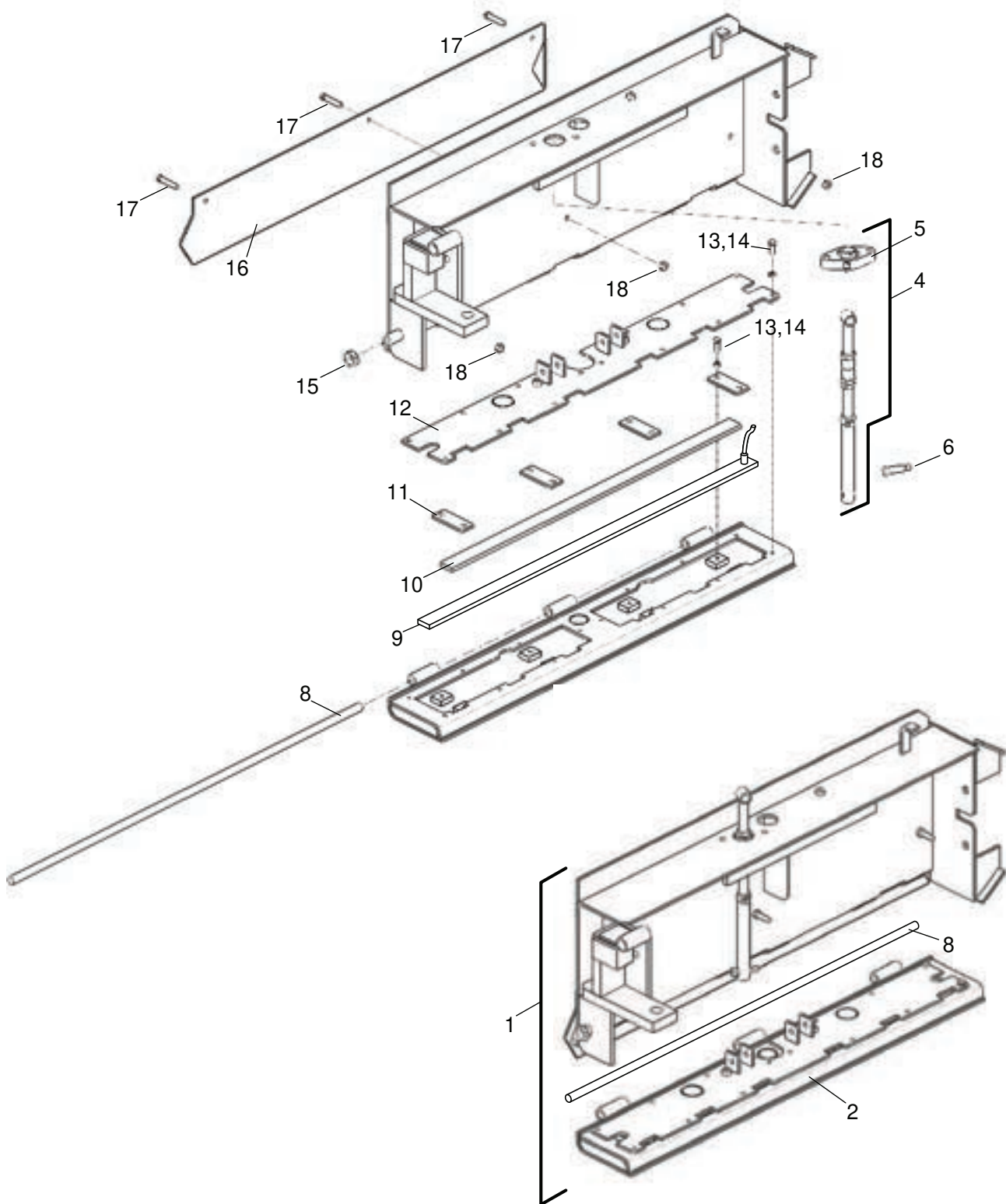

Figure 7-58. Option - Legend Screed Extension Single Adjust - Left

Option - Legend Screed Extension Single Adjust - Left

Item No	Part Number	Qty	Description	Remarks
1	985561SRV	1	Extension Assembly - Left	
2	987872SRV	1	Heat Box Assembly - Single Adjust	
4	851185SRV	1	Extension Adjust Screw Assembly	
5	870030	1	Screed Flight Screw Bearing	
6	118-8-32-3/8x1	1	Shoulder Bolt, 1/2 x 2L, 3/8 x 16	
8	854447SRV	1	Round, .688 x 43.50, CRS	
9	987890SRV	1	Heater Element, 1000W/220V, 41"	
10	985120	1	Bar, .250 x 1.50 x 36	
11	985123	4	Screed Extension Element Clamp	
12	988291	1	Heat Box Cover Assembly - Single Adjust	
13	302-6	22	Washer, Lock, 3/8	
14	100-6-24-16-8F	22	CSHH, 3/8-24 x 1.00, GR8, FT	
15	205-14-9-5	1	Nut, Nylon Lock, 7/8-9, GR5	
16	851180LSRV	1	Screed Extension Hinge Guard - Left	
17	100-5-18-20-5	3	CSHH, 5/16-18 x 1.25, GR5	
18	200-5-18-5	3	Nut, Hex, 5/16-18, GR5	

Illustrated Parts List

OPTION - LEGEND SCREED EXTENSION SINGLE ADJUST - RIGHT

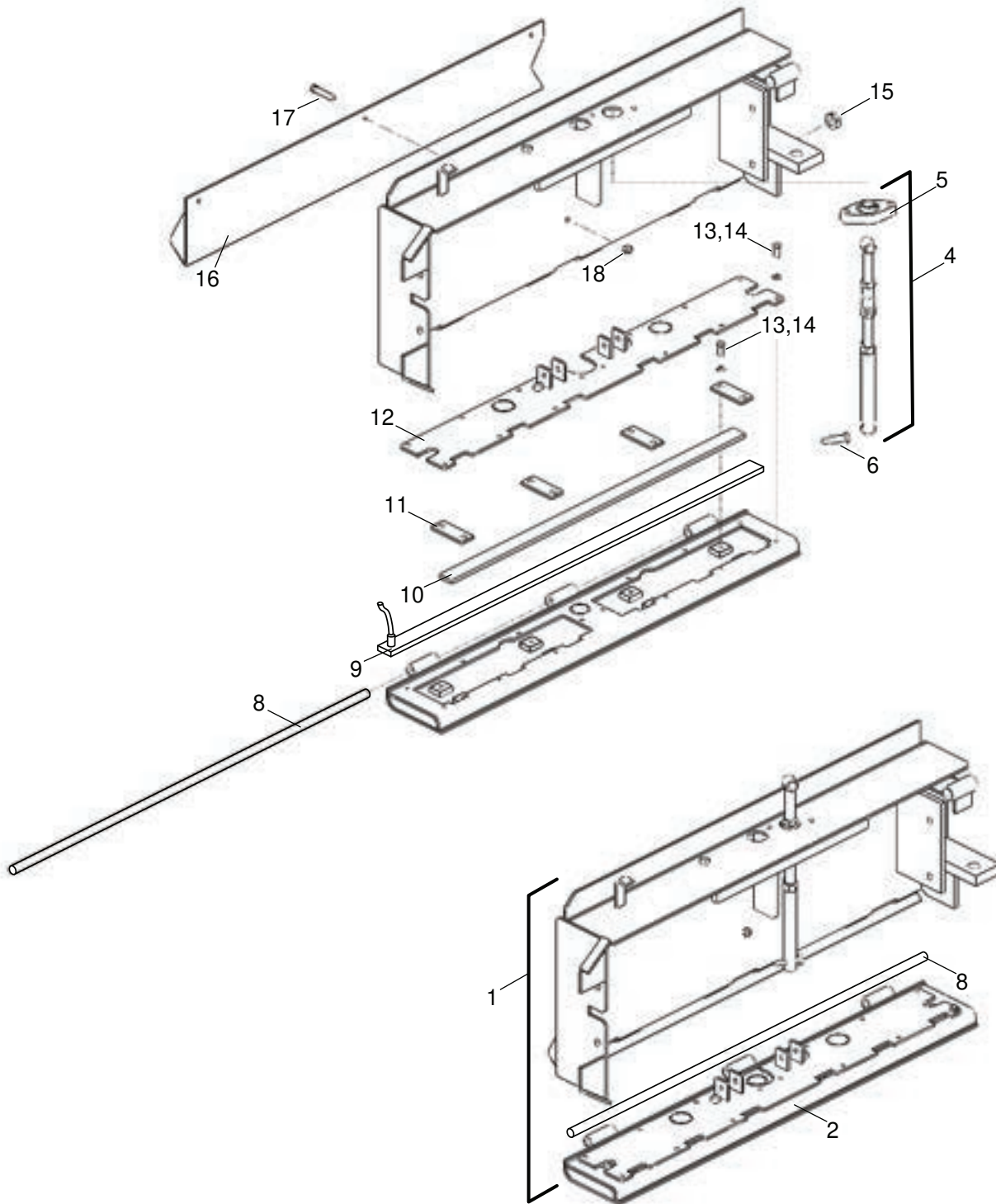

Figure 7-59. Option - Legend Screed Extension Single Adjust - Right

Option - Legend Screed Extension Single Adjust - Right

Item No	Part Number	Qty	Description	Remarks
1	985562SRV	1	Extension Assembly - Right	
2	987872SRV	1	Heat Box Assembly - Single Adjust	
4	851185SRV	1	Extension Adjust Screw Assembly	
5	870030	1	Screed Flight Screw Bearing	
6	118-8-32-3/8x1	1	Shoulder Bolt, 1/2 x 2L, 3/8 x 16	
8	854447SRV	1	Round, .688 x 43.50, CRS	
9	987890SRV	1	Heater Element, 1000W/220V, 41"	
10	985120	1	Bar, .250 x 1.50 x 36	
11	985123	4	Screed Extension Clamp, Element	
12	988291	1	Heat Box Cover Assembly - Single Adjust	
13	302-6	22	Washer, Lock, 3/8	
14	100-6-24-16-8F	22	CSHH, 3/8-24 x 1.00, GR8, FT	
15	205-14-9-5	1	Nut, Nylon Lock, 7/8-9, GR5	
16	851180RSRV	1	Screed Extension Hinge Guard - Right	
17	100-5-18-20-5	3	CSHH, 5/16-18 x 1.25, GR5	
18	200-5-18-5	3	Nut, Hex, 5/16-18, GR5	

Illustrated Parts List

OPTION - LEGEND SCREED EXTENSION 4-WAY ADJUST - LEFT

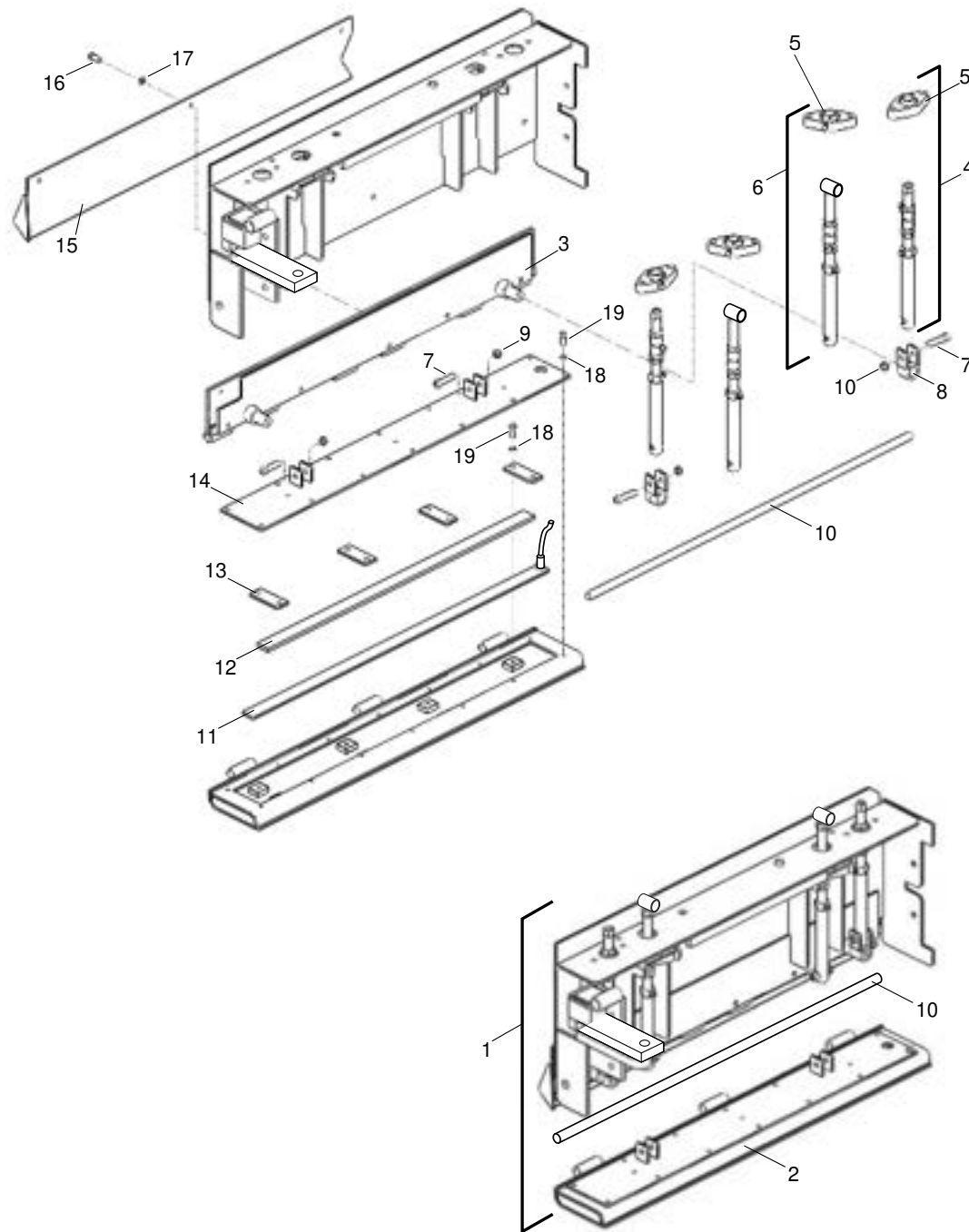

Figure 7-60. Option - Legend Screed Extension 4-Way Adjust - Left

Option - Legend Screed Extension 4-Way Adjust - Left

Item No	Part Number	Qty	Description	Remarks
1	984305SRV	1	Extension Assembly w/Slope - Left	
REF	984305-1SRV	1	Extension Assembly w/o Slope - Left	Not Shown
2	988319SRV	1	Heat Box Assembly - 4 Adjust	
3	1002735SRV	1	Hinge Assembly	
4	985556SRV	1	Slide Adjust Assembly	
5	870030	4	Screed Flight Screw Bearing	
6	851185SRV	1	Extension Adjust Screw Assembly	
7	118-8-32-3/8x16	4	Shoulder Bolt, 1/2 x 2L, 3/8 x 16	
8	1002715SRV	1	Adjuster Mount	
9	204-6-16-5	4	Nut, Lock, Stover, 3/8-16, GR5	
10	854447SRV	1	Round, .688 x 43.50, CRS	
11	987890SRV	1	Heater Element, 1000W/220V, 41"	
12	985120	1	Bar, .250 x 1.50 x 36	
13	985123	4	Screed Extension Element Clamp	
14	988292SRV	1	Heat Box Cover Assembly - 4 Adjust	
15	851180LSRV	1	Screed Extension Hinge Guard - Left	
16	100-6-16-32-5	3	CSHH, 3/8-16 x 2.00, GR5	
17	302-6	3	Washer, Lock, 3/8	
18	302-4	22	Washer, Lock, 1/4	
19	100-4-20-16-5F	22	CSHH, 1/4-20 x 1.00, GR5, FT	

Illustrated Parts List

OPTION - LEGEND SCREED EXTENSION 4-WAY ADJUST - RIGHT

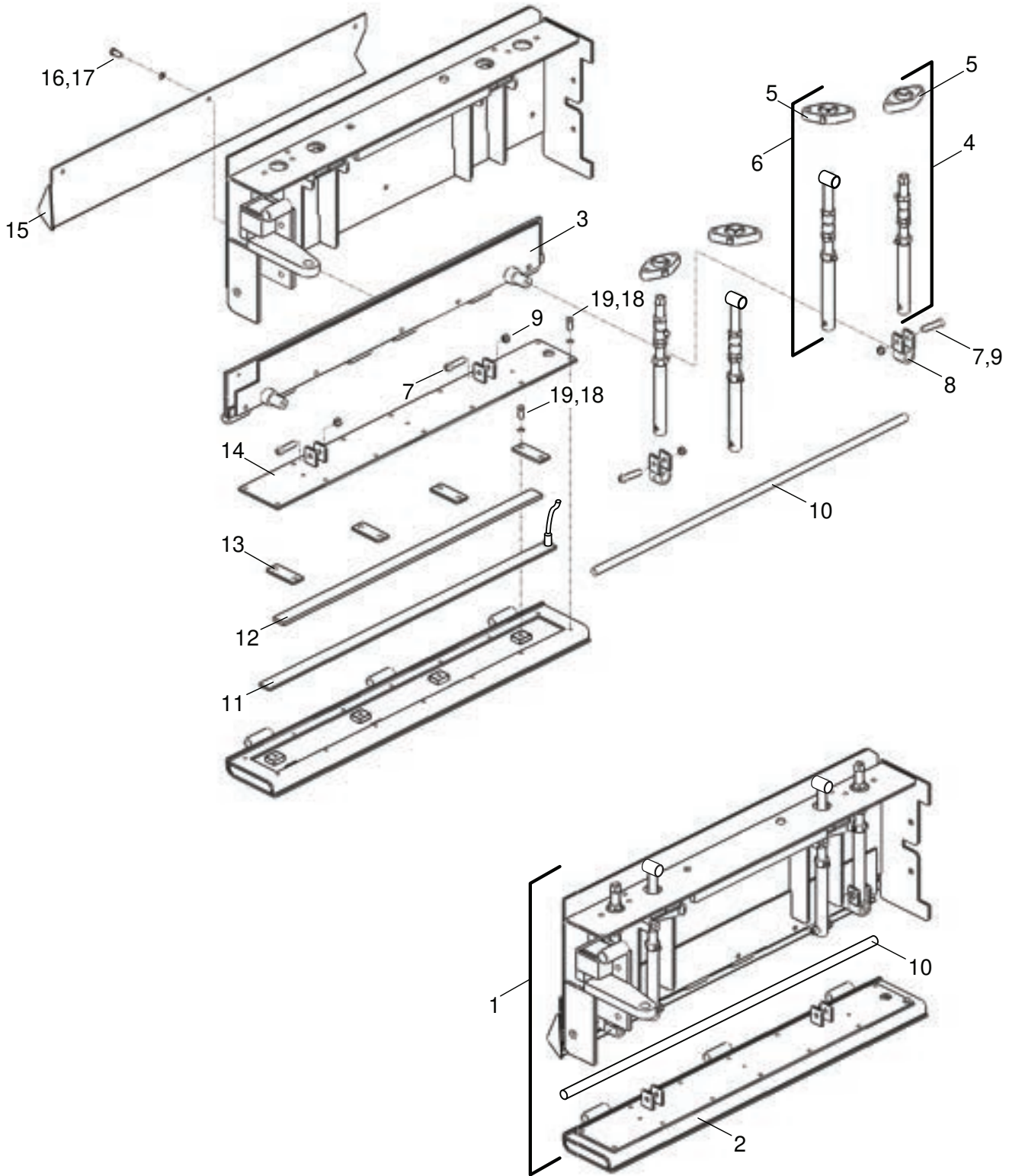

Figure 7-61. Option - Legend Screed Extension 4-Way Adjust - Right

Option - Legend Screed Extension 4-Way Adjust - Right

Item No	Part Number	Qty	Description	Remarks
1	984306SRV	1	Extension Assembly w/Slope - Right	
REF	984306-1SRV	1	Extension Assembly w/o Slope - Right	Not Shown
2	988319SRV	1	Heat Box Assembly - 4 Adjust	
3	1002736SRV	1	Hinge Assembly	
4	985556SRV	1	Slide Adjustment Assembly	
5	870030	4	Screed Flight Screw Bearing	
6	851185SRV	1	Extension Adjust Screw Assembly	
7	118-8-32-3/8x16	4	Shoulder Bolt, 1/2 x 2L, 3/8 x 16	
8	1002715SRV	1	Adjuster Mount	
9	204-6-16-5	4	Nut, Lock, Stover, 3/8-16, GR5	
10	854447SRV	1	Round, .688 x 43.50, CRS	
11	987890SRV	1	Heater Element, 1000W/220V, 41"	
12	985120	1	Bar, .250 x 1.50 x 36	
13	985123	4	Screed Extension Element Clam	
14	988292SRV	1	Heat Box Cover Assembly - 4 Adjust	
15	851180RSRV	1	Screed Extension Hinge Guard - Right	
16	100-6-16-32-5	3	CSHH, 3/8-16 x 2.00, GR5	
17	302-6	3	Washer, Lock, 3/8	
18	302-4	22	Washer, Lock, 1/4	
19	100-4-20-16-5F	22	CSHH, 1/4-20 x 1.00, GR5, FT	

Illustrated Parts List

OPTION - LEGEND SCREED SLIDE PLATES

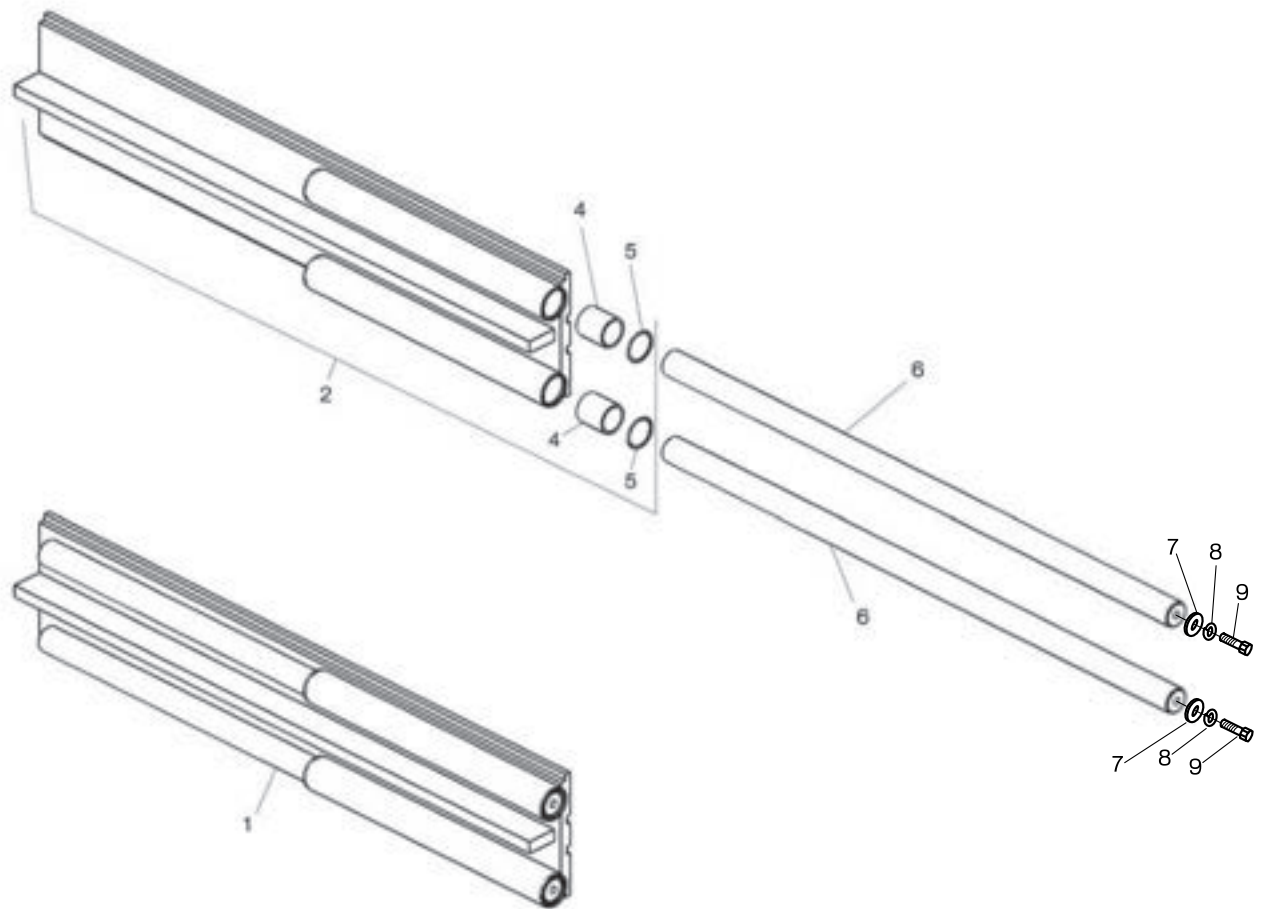

Figure 7-62. Option - Legend Screed Slide Plates

Option - Legend Screed Slide Plates

Item No	Part Number	Qty	Description	Remarks
1	1002186	1	Slide Plate Assembly w/Chrome Rods	
2	1002181	1	Slide Plate Assembly	
4	988588	4	Bushing	
5	851256	4	Snap Ring	
6	988601	2	Chrome Rod	
7	300-8	4	Washer, Flat, SAE, 1/2	
8	302-8	4	Washer, Lock, 1/2	
9	100-8-20-24-5	4	CSHH, 1/2-20 x 1.50, GR5	

Illustrated Parts List

OPTION - LEGEND SCREED PULL ARM ASSEMBLY - LEFT

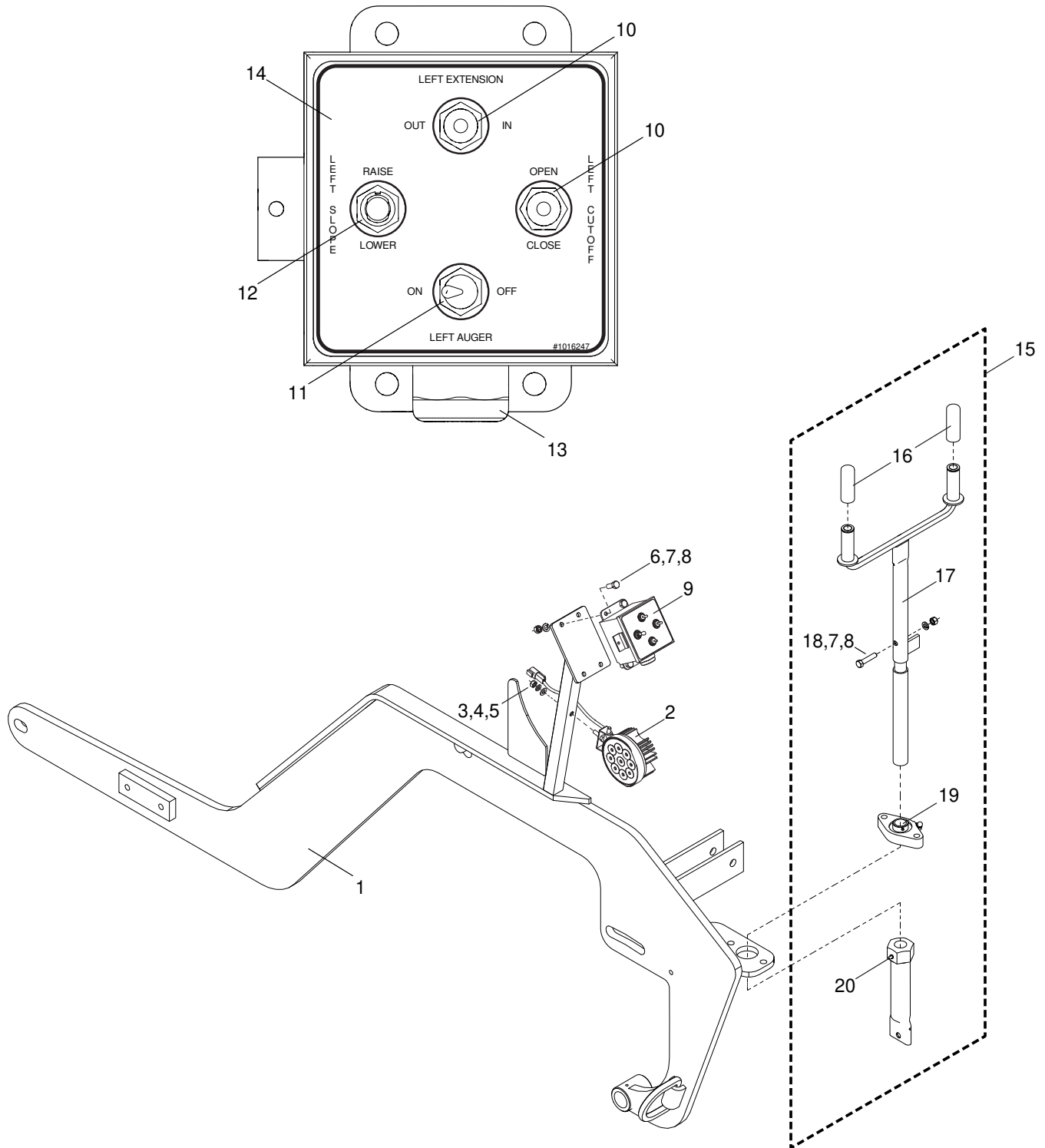

Figure 7-63. Option - Legend Screed Pull Arm Assembly - Left

Option - Legend Screed Pull Arm Assembly - Left

Item No	Part Number	Qty	Description	Remarks
1	984897SRV	1	Screed Pull Arm Assembly - Left	
2	1013307	1	LED Circular Light w/Deutsch Connector	
3	200-5-18-5	1	Nut, Hex, 5/16-18, GR5	
4	302-5	1	Washer, Lock, 5/16	
5	300-5	1	Washer, Flat, SAE, 5/16	
6	100-6-16-16-5F	4	CSHH, 3/8-16 x 1.00, GR5, FT	
7	302-6	5	Washer, Lock, 3/8	
8	200-6-16-5	5	Nut, Hex, 3/8-16, GR5	
9	1016618	1	Screed Control Box, 4 Switch - Left	
10	851392	2	Toggle Switch, 3-POS, SPDT, MOM	
11	851391	1	Toggle Switch, 2-POS	
12	851393	1	Toggle Switch	
13	3400DI	1	Water Tight Connector, 3/4 x 3/4 MPT	
14	1016247	1	Decal - Screed Control Operation - Left	
15	851370SRV	1	Flight Screw Assembly	
16	870276	2	Flight/Depth Screw Hand Grip	
17	859365	1	Flight Screw Sub-Assembly	
18	100-6-16-28-5	1	CSHH, 3/8-16 x 1.75, GR5	
19	870030	1	Screed Flight Screw Bearing	
20	140610	1	Straight Lube Fitting, 1/4-28	

Illustrated Parts List

OPTION - LEGEND SCREED PULL ARM ASSEMBLY - RIGHT

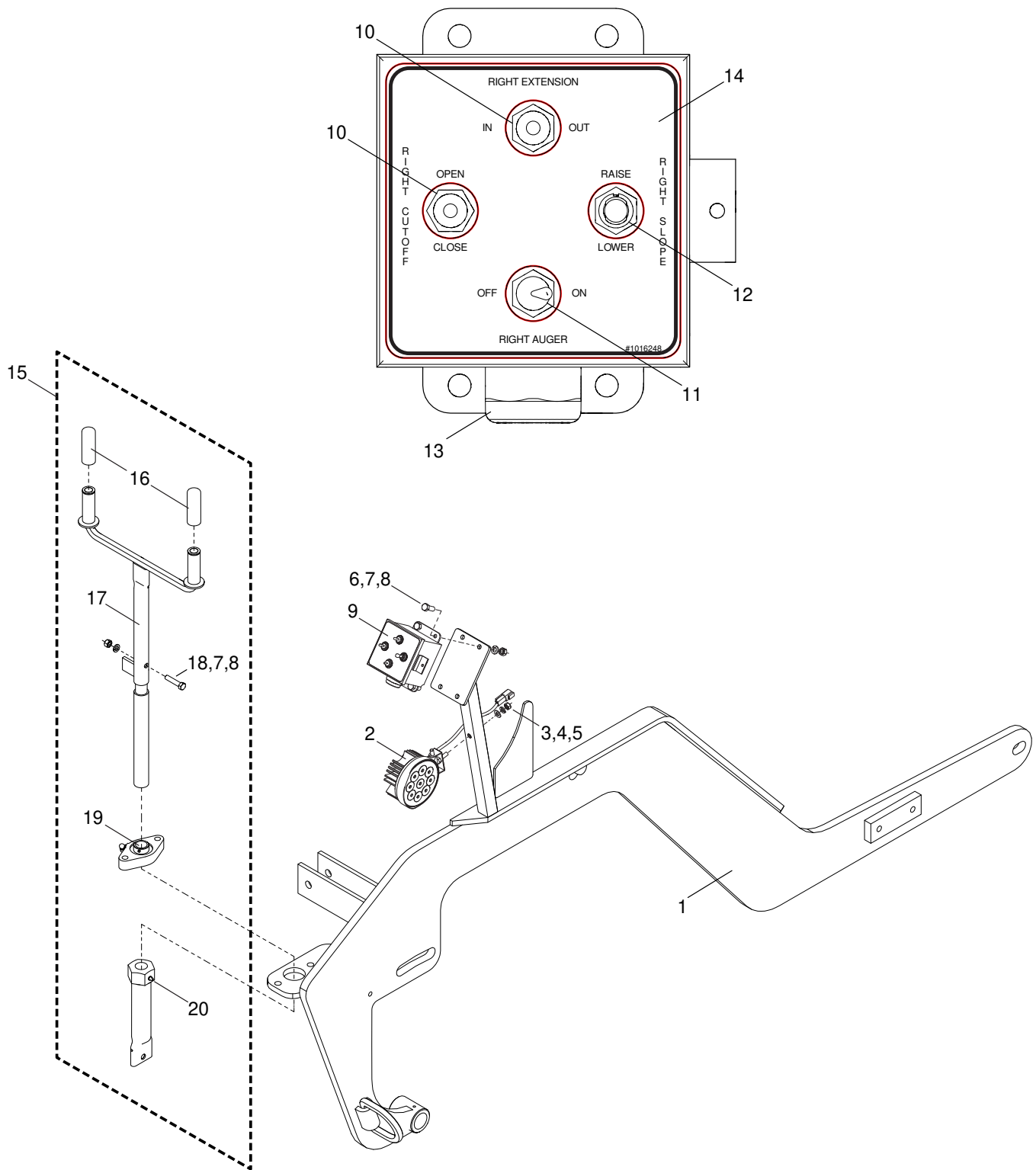

Figure 7-64. Option - Legend Screed Pull Arm Assembly - Right

Option - Legend Screed Pull Arm Assembly - Right

Item No	Part Number	Qty	Description	Remarks
1	984896SRV	1	Screed Pull Arm Assembly - Right	
2	1013307	1	LED Circular Light w/Deutsch Connector	
3	200-5-18-5	1	Nut, Hex, 5/16-18, GR5	
4	302-5	1	Washer, Lock, 5/16	
5	300-5	1	Washer, Flat, SAE, 5/16	
6	100-6-16-16-5F	4	CSHH, 3/8-16 x 1.00, GR5, FT	
7	302-6	5	Washer, Lock, 3/8	
8	200-6-16-5	5	Nut, Hex, 3/8-16, GR5	
9	1016617	1	Screed Control Box, 4 Switch - Right	
10	851392	2	Toggle Switch, 3-POS, SPDT, MOM	
11	851391	1	Toggle Switch, 2-POS	
12	851393	1	Toggle Switch	
13	3400DI	1	Water Tight Connector, 3/4 x 3/4 MPT	
14	1016248	1	Decal - Screed Control Operation - Right	
15	851370SRV	1	Flight Screw Assembly	
16	870276	2	Flight/Depth Screw Hand Grip	
17	859365	1	Flight Screw Sub-Assembly	
18	100-6-16-28-5	1	CSHH, 3/8-16 x 1.75, GR5	
19	870030	1	Screed Flight Screw Bearing	
20	140610	1	Straight Lube Fitting, 1/4-28	

Illustrated Parts List

OPTION - LEGEND SCREED ENDGATE - LEFT

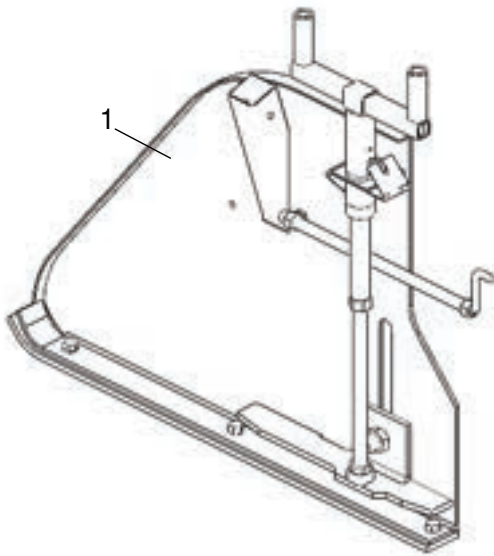
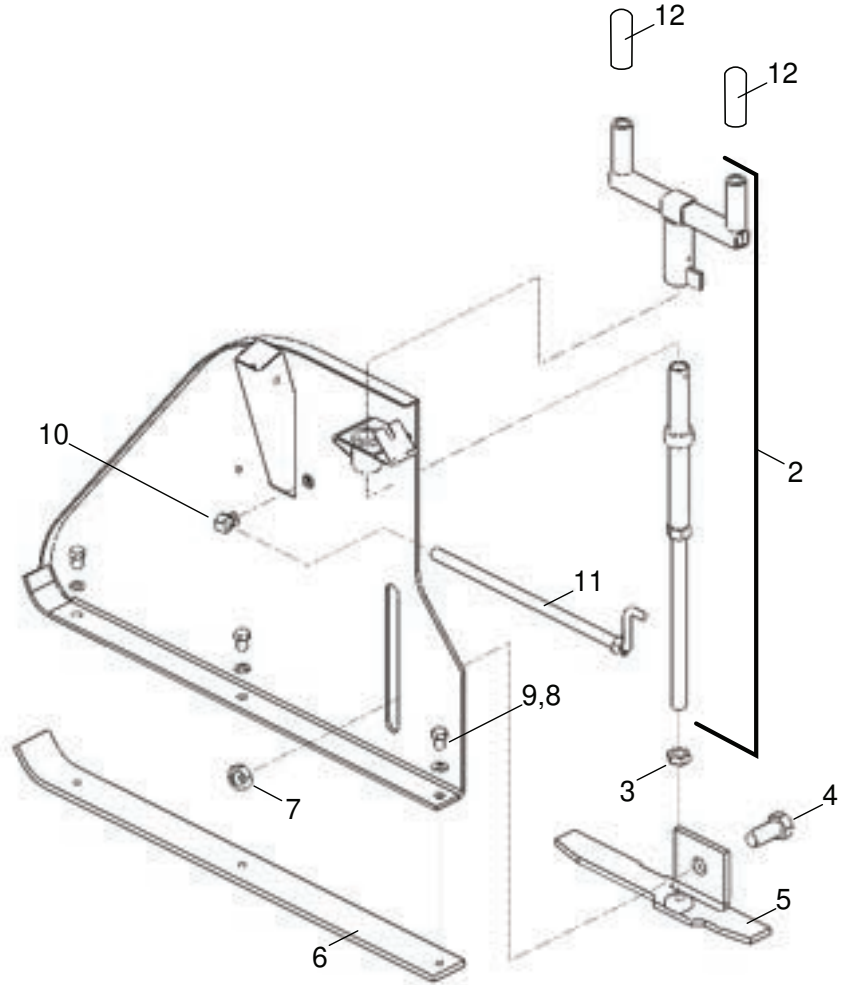
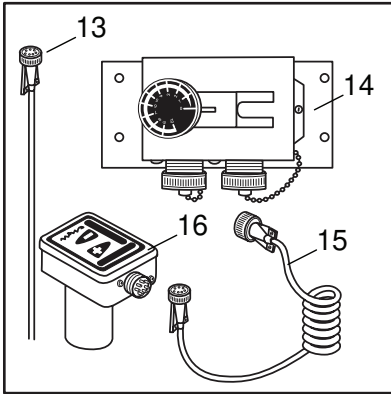

Figure 7-65. Option - Legend Screed Endgate - Left

Option - Legend Screed Endgate - Left

Item No	Part Number	Qty	Description	Remarks
1	983308SRV	1	Endgate Assembly - Left	
2	890092SRV	1	Screed Depth Screw Assembly	
3	202-12-10-5	1	Nut, Hex, Jam 3/4-10, GR5	
4	100-14-9-32-5F	1	CSHH, 7/8-9 x 2.00, GR5, FT	
5	890132LSRV	1	Depth Screw Control Bracket - Left	
6	982963SRV	1	End Gate Skid Bar	
7	205-14-9-5	1	Nut, Nylon Lock. 7/8-9, GR5	
8	302-8	3	Washer, Lock, 1/2	
9	100-8-13-12-5F	3	CSHH, 1/2-13 x .75, GR5, FT	
10	890070	1	Adjusting Swivel Nut Assembly	
11	890081SRV	1	Endgate Tilt Screw Assembly	
12	870276	2	Flight/Depth Screw Hand Grip	
13	982796	1	Ultrasonic Power Cable	
14	982795	1	Ultra Sonic Remote Pod	
15	983050	1	Coil Cord, 6s/6s 1.5 to 7.5 FT	
16	982794	1	Ultra Sonic Sensor	

Illustrated Parts List

OPTION - LEGEND SCREED ENDGATE - RIGHT

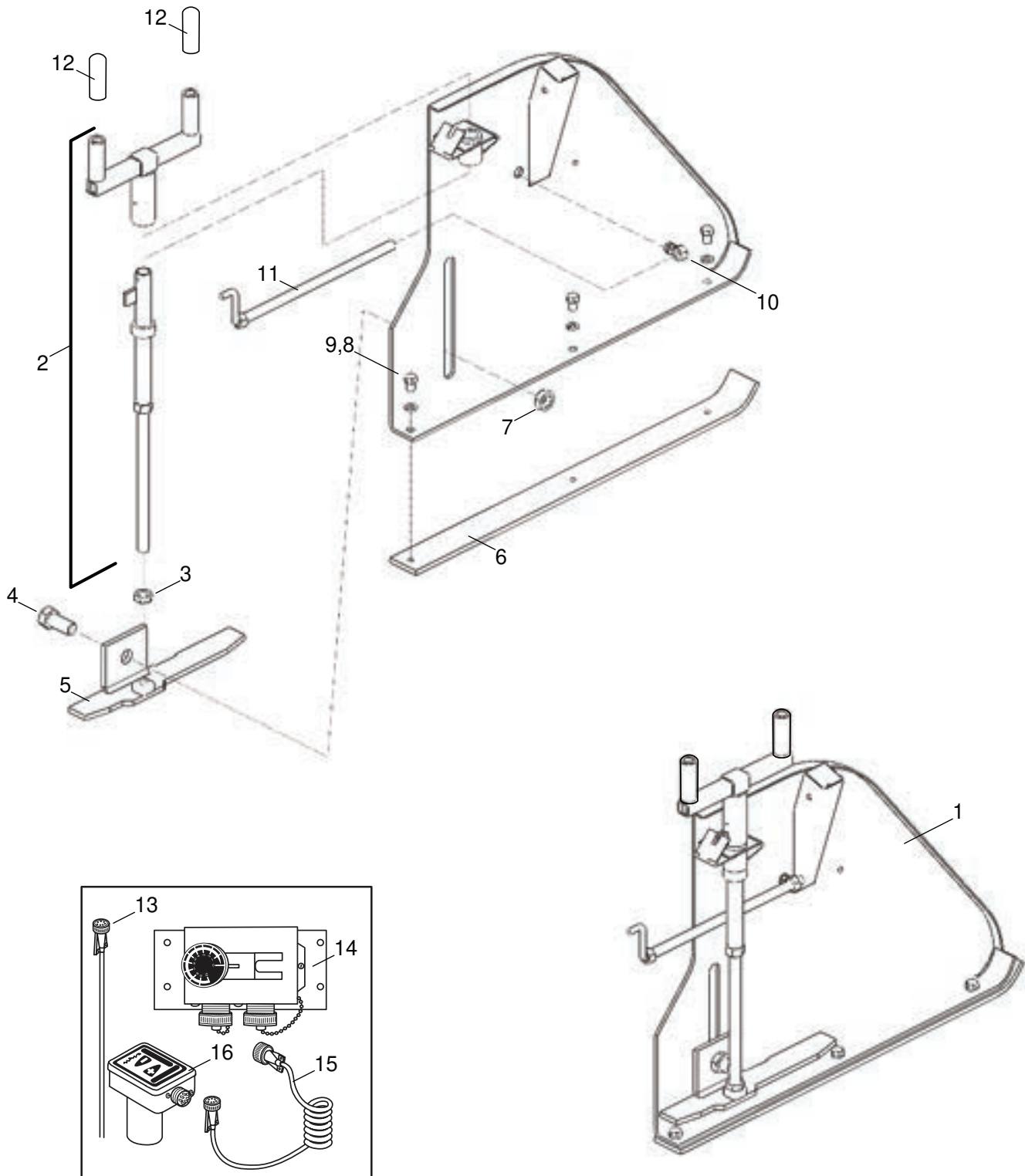

Figure 7-66. Option - Legend Screed Endgate - Right

Option - Legend Screed Endgate - Right

Item No	Part Number	Qty	Description	Remarks
1	983309SRV	1	Endgate Assembly - Right	
2	890092SRV	1	Screed Depth Screw Assembly	
3	202-12-10-5	1	Nut, Hex, Jam 3/4-10, GR5	
4	100-14-9-32-5F	1	CSHH, 7/8-9 x 2.00, GR5, FT	
5	890132RSRV	1	Depth Screw Control Bracket - Left	
6	982963SRV	1	End Gate Skid Bar	
7	205-14-9-5	1	Nut, Nylon Lock. 7/8-9, GR5	
8	302-8	3	Washer, Lock, 1/2	
9	100-8-13-12-5F	3	CSHH, 1/2-13 x .75, GR5, FT	
10	890070	1	Adjusting Swivel Nut Assembly	
11	890081SRV	1	Endgate Tilt Screw Assembly	
12	870276	2	Flight/Depth Screw Hand Grip	
13	982796	1	Ultrasonic Power Cable	
14	982795	1	Ultra Sonic Remote Pod	
15	983050	1	Coil Cord, 6s/6s 1.5 to 7.5 FT	
16	982794	1	Ultra Sonic Sensor	

Illustrated Parts List

OPTION - LEGEND SCREED CITRUS TANK

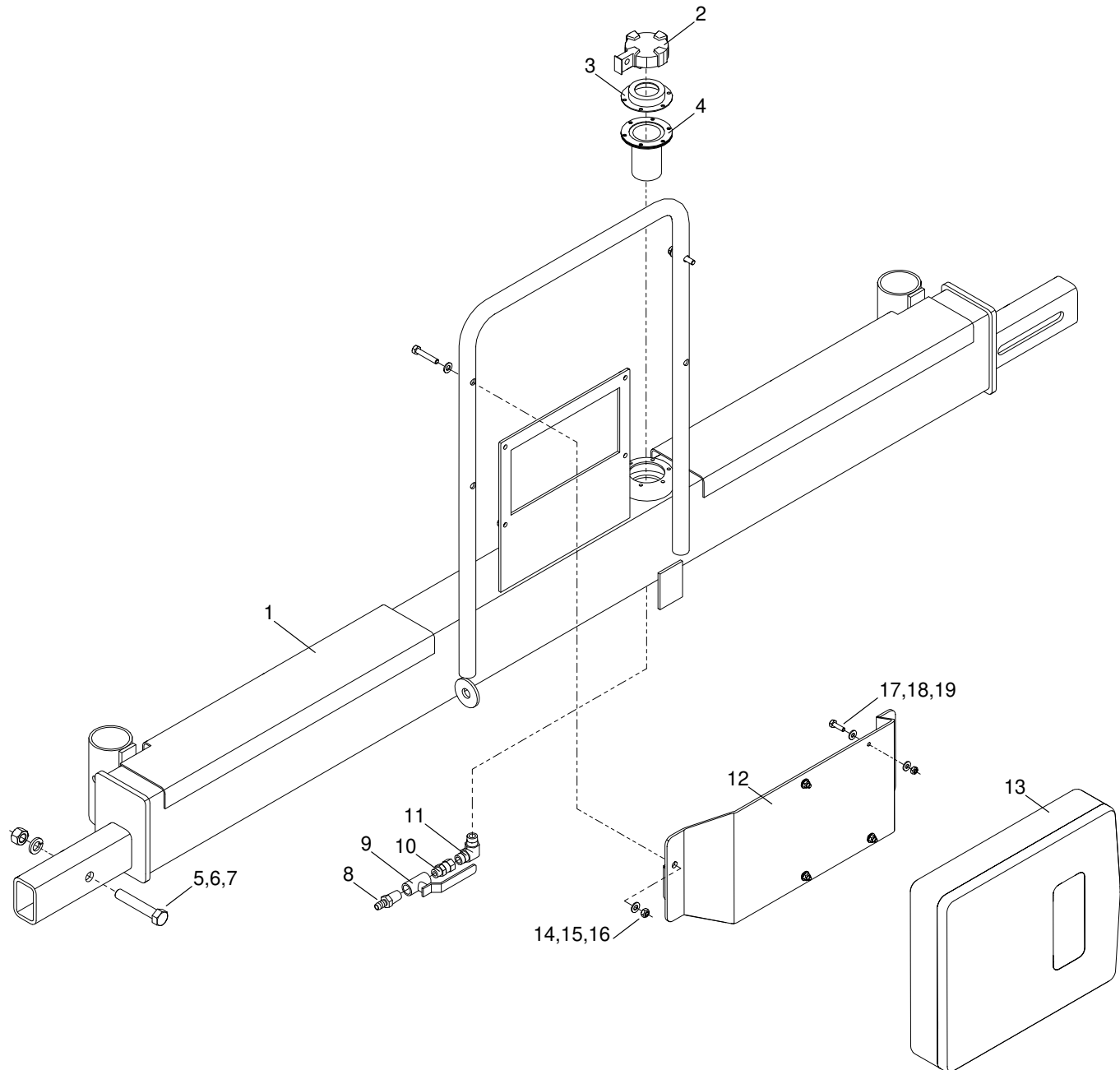

Figure 7-67. Option - Legend Screed Citrus Tank

Option - Legend Screed Citrus Tank

Item No	Part Number	Qty	Description	Remarks
1	1008862SRV	1	Legend Screed Citrus Tank Assembly	Includes Items 2 - 7
2	140030FL	1	Fuel Tank Cap - Lockable	
3	140030FN	1	Fuel Cap Filler Neck	
4	140030GK	1	Fuel Filler Strainer & Gasket Kit	
5	100-10-11-60-5	2	CSHH, 5/8-11 x 3.50, GR5	
6	302-10	2	Washer, Lock, 5/8	
7	200-10-11-5	2	Nut, Hex, 5/8-11, GR5	
8	31959	1	Straight Fitting, 06MP-06HB, Push On	
9	480160	1	Ball Valve - 3/8	
10	6274	1	Straight Fitting, 06MP-06FPX	
11	853211085	1	90° Fitting, 06MP-06MP	
12	1016514	1	Tool Tray Assembly	
13	985234-01	1	Manual Case	
14	100-5-18-28-5	2	CSHH, 5/16-18 x 1.75, GR5	
15	300-5	4	Washer, Flat, SAE, 5/16	
16	204-5-18-5	2	Nut, Lock, Stover, 5/16-18, GR5	
17	100-4-20-14-5	4	CSHH, 1/4-20 x .875, GR5	
18	300-4	8	Washer, Flat, SAE, 1/4	
19	204-4-20-5	4	Nut, Lock, Stover, 1/4-20, GR5	

Illustrated Parts List

OPTION - LEGEND SCREED POWER CROWN

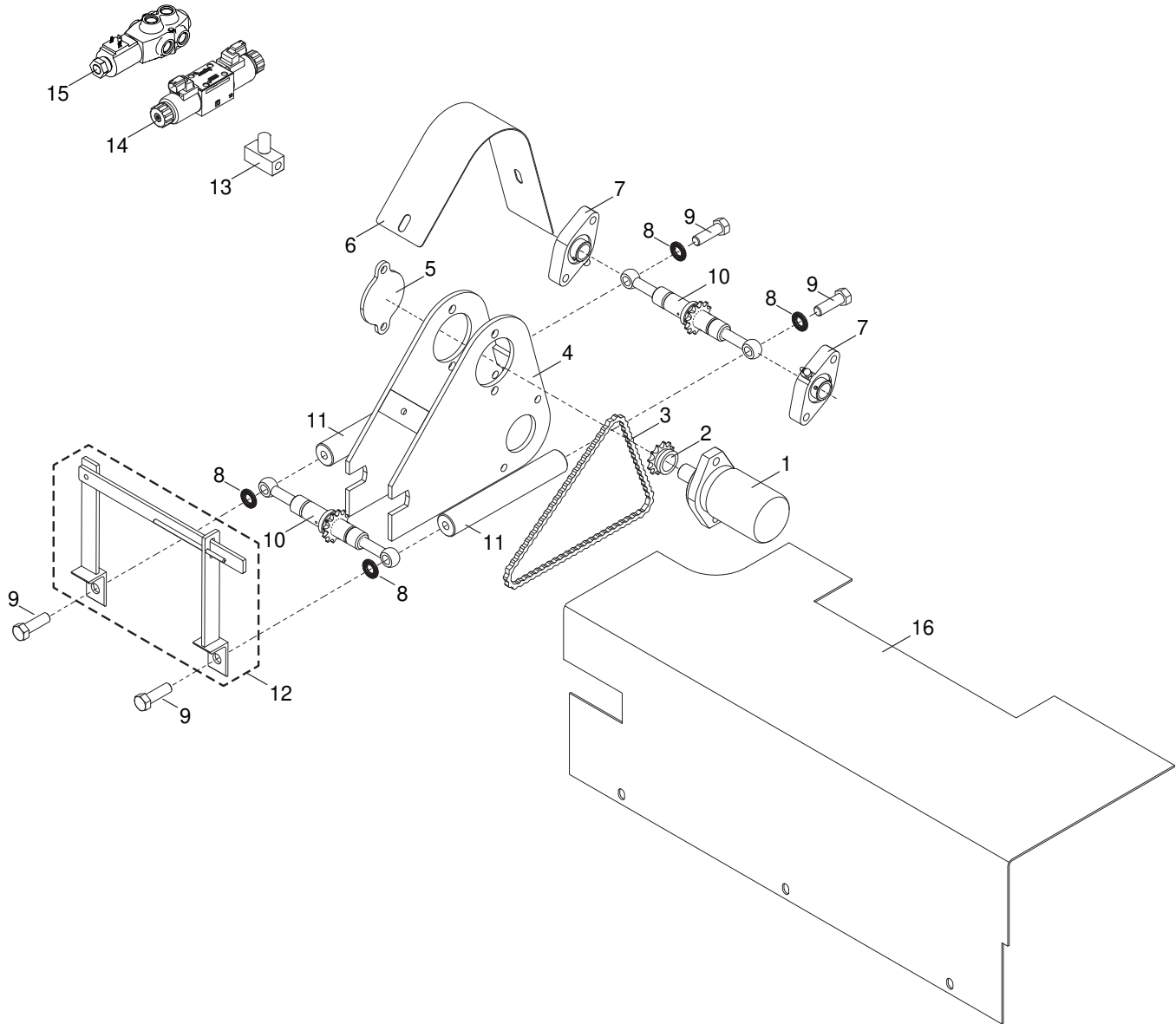

Figure 7-68. Option - Legend Screed Power Crown

Option - Legend Screed Power Crown

Item No	Part Number	Qty	Description	Remarks
1	986640	1	Hydraulic Motor	
2	986641	1	Sprocket, 40 Roller 12T	
3	986639SRV	1	Chain, 40 Roller	
4	986645	1	Crown Frame	
5	986644	1	Cover	
6	986643	1	Chain Shield	
7	870030	2	Bearing	
8	986811	4	Nord Wedge Lock Washer, .670	
9	100-10-11-32-5	4	CSHH, 5/8-11 x 2.00, GR5	
10	986637SRV	2	Turnbuckle Assembly	
REF	986650	A/R	Extension Rod - Left	Included with Item 10
REF	986636	A/R	Extension Rod - Right	Included with Item 10
11	854491	2	Crown Adjust Mount	
12	1006637	1	Crown & Valley Gauge Assembly	
13	35552	1	Hydraulic Needle Valve	
14	983643-01	1	Directional Solenoid Valve	
15	989656	1	Valve	
16	988110	1	Power Crown Screed Cover - Right (Used in place of 985147 (Fig, 7-53, Item 19) with Power Crown Option)	

Illustrated Parts List

OPTION - SCREED AUTOMATIC TEMPERATURE CONTROLLER

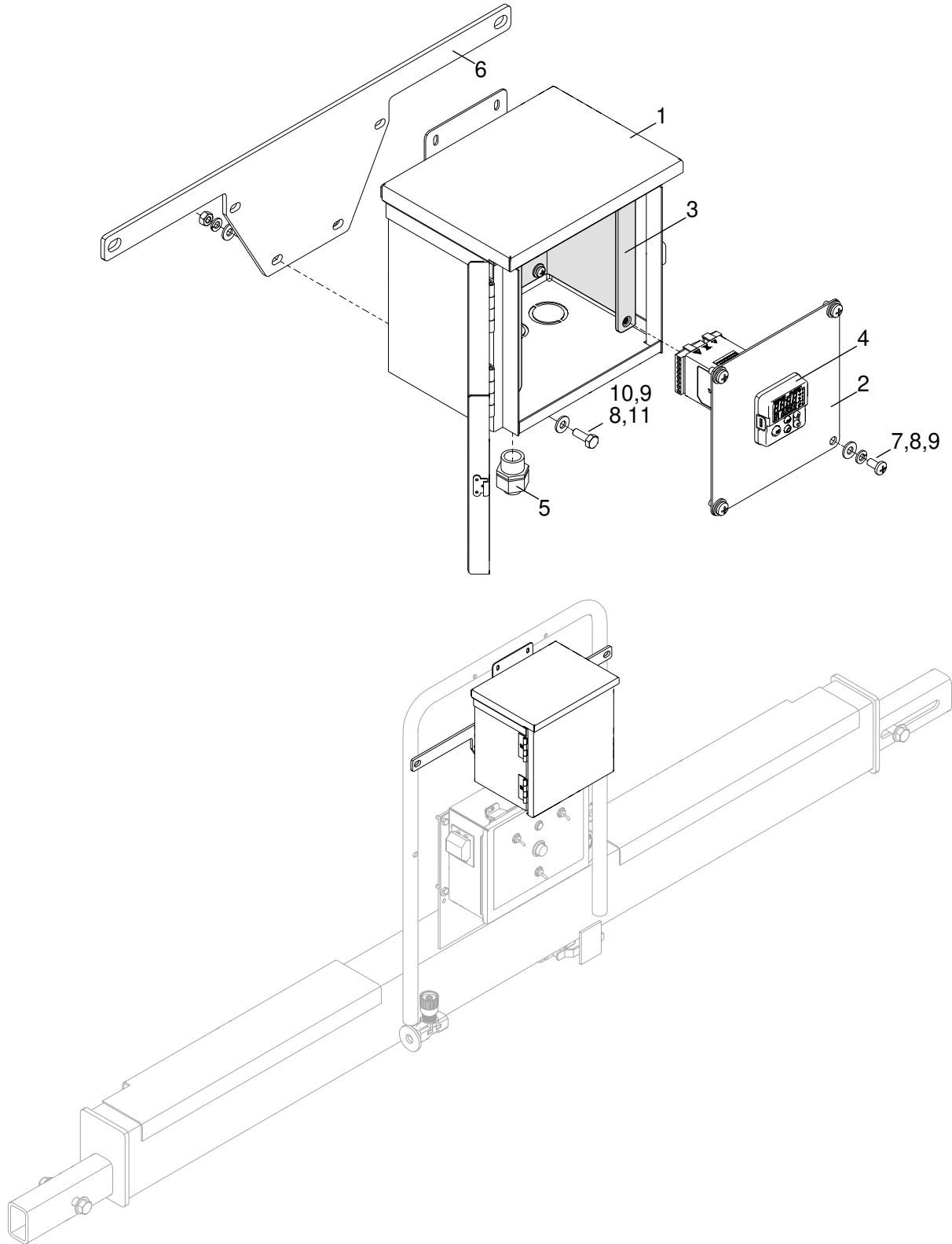

Figure 7-69. Option - Automatic Temperature Controller

Option - Screed Automatic Temperature Controller

Item No	Part Number	Qty	Description	Remarks
OPT	1017744	1	OPTION - Automatic Temperature Controller	
1	1017395	1	Enclosure, Rain-Tight, 8H x 8W x 6D	
2	1017739	1	Mounting Plate, Watlow	
3	1017737	1	Mounting Bracket, Watlow	
4	1017392	1	Temperature Controller, Watlow PM6	
5	3200DI	1	Connector, Water-Tight, 1/2 x 1/2 MPT	
6	1017746	1	Control Box Mounting Plate	
7	122-4-20-8F	4	PHMS, Cross, 1/4-20 x .50, FT	
8	302-4	6	Washer, Lock, 1/4	
9	300-4	8	Washer, Flat, SAE, 1/4	
10	100-4-20-12-5F	2	CSHH, 1/4-20 x .75, GR5, FT	
11	200-4-20-5	2	Nut, Hex, 1/4-20, GR5	

Illustrated Parts List

OPTION - DUAL STEERING WHEELS

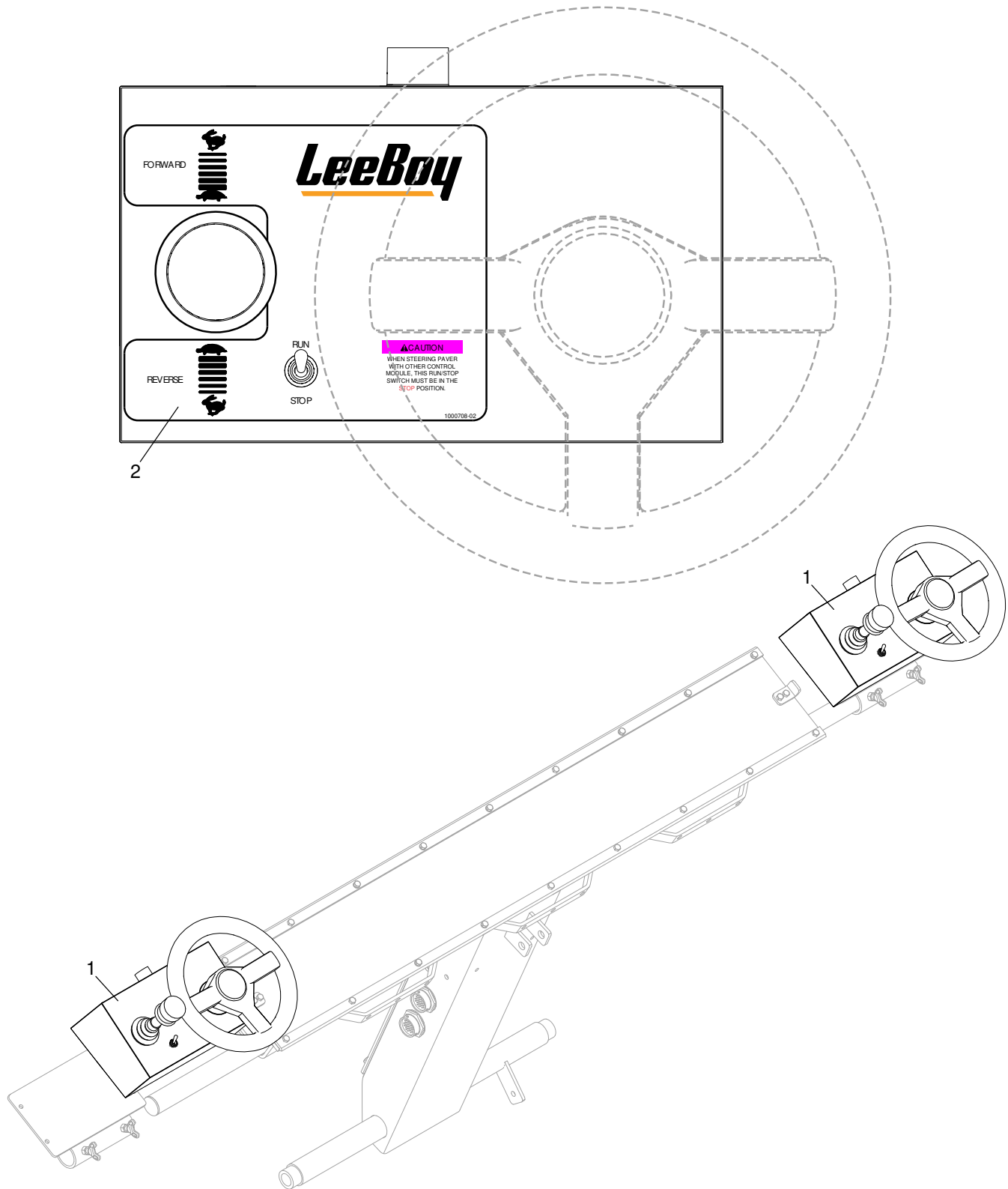

Figure 7-70. Option - Dual Steering Wheels

Option - Dual Steering Wheel

Item No	Part Number	Qty	Description	Remarks
OPT	1004842SRV		Group - Steering Wheel Option	
1	1000708	2	Steering Wheel Box	
2	1002080	2	Decal - Steering Wheel Operations	

Illustrated Parts List

OPTION - 12" AUGER EXTENSION

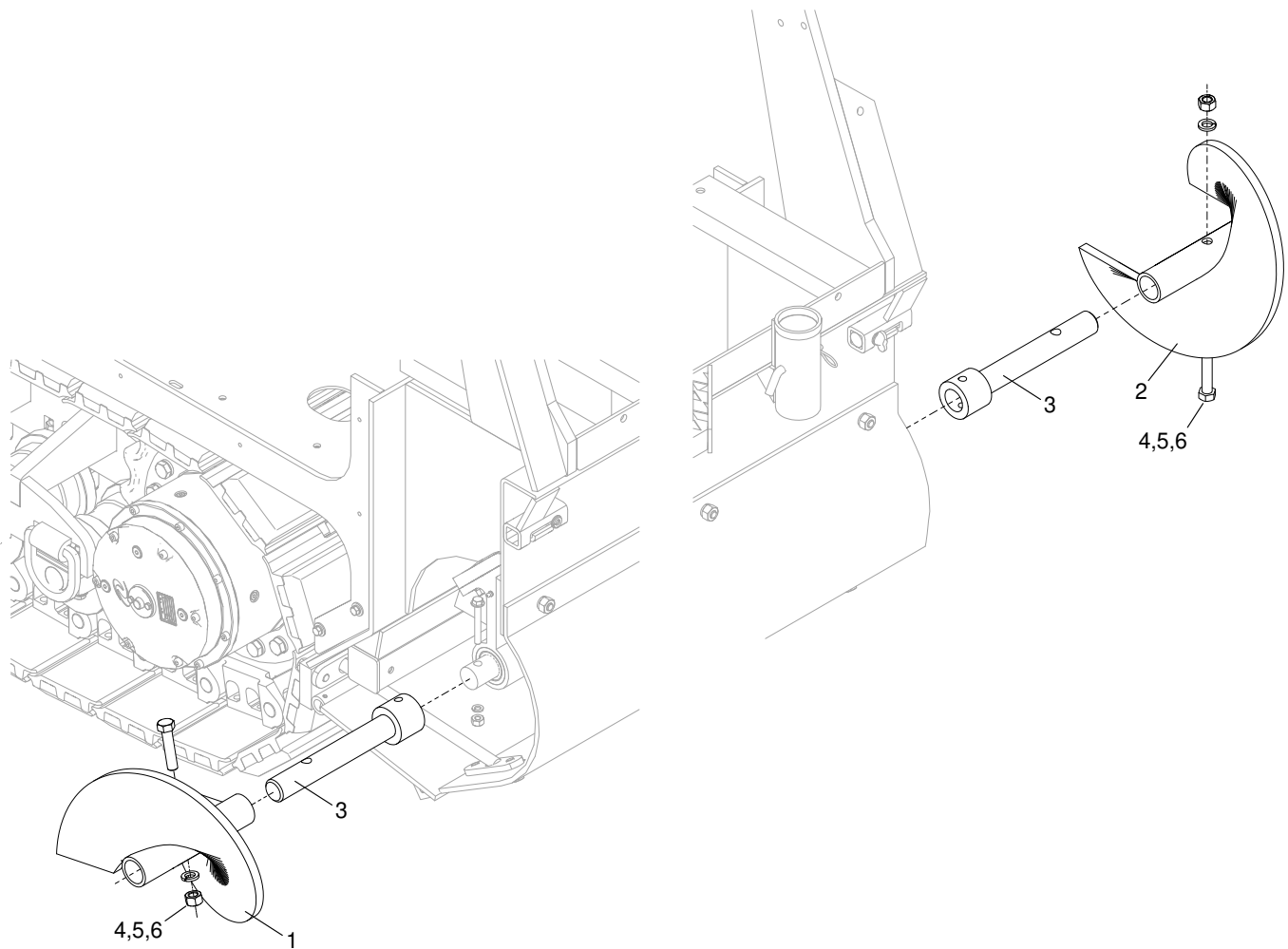

Figure 7-71. Option - 12" Auger Extension

Option - 12" Auger Extension

Item No	Part Number	Qty	Description	Remarks
OPT	985797SRV		Option - 12" Auger Extension	
REF	985795SRV	1	12" Auger Extension Assembly - Left	Includes Items 1, 3 - 6
REF	985796SRV	1	12" Auger Extension Assembly - Right	Includes Items 2 - 6
1	981700L	1	12" Auger Flight - Left	
2	981700R	1	12" Auger Flight - Right	
3	985794	2	Auger Extension Shaft Weldment	(1) Per Assembly
4	100-10-11-44-5	2	CSHH, 5/8-11 x 2.75, GR5	(1) Per Assembly
5	302-10	2	Washer, Lock, 5/8	(1) Per Assembly
6	200-10-11-5	2	Nut, Hex, 5/8-11, GR5	(1) Per Assembly

Illustrated Parts List

OPTION - 24" AUGER EXTENSION

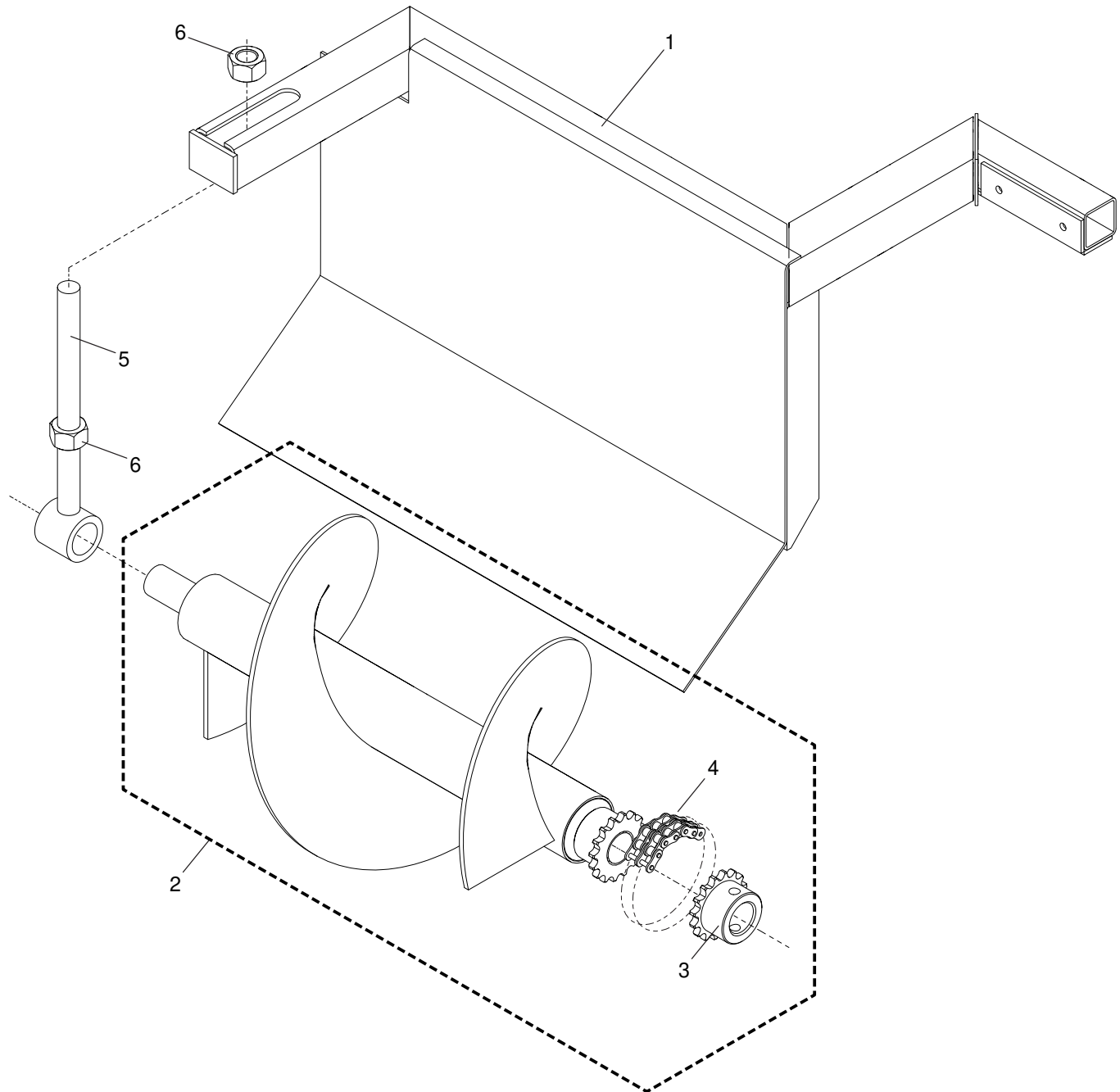

Figure 7-72. Option - 24" Auger Extension

Option - 24" Auger Extension

Item No	Part Number	Qty	Description	Remarks
OPT	982521SRV	1	Option - 24" Auger Extension w/Shield	
1	851228SRV	1	24" Auger Extension Shield - Left	
REF	851227SRV	1	24" Auger Extension Shield - Right	Not Shown
2	851230SRV	1	24" Auger Extension - Left	Includes Items 3 & 4
REF	851229SRV	1	24" Auger Extension - Right	Not Shown, Includes Items 3 & 4
3	854003	2	Chain Coupling Sprocket Half w/Hole	
4	900404	2	Double Row Chain Assembly, 50-2	
5	851231SRV	2	Auger Extension Support	
6	200-16-8-5	4	Nut, Hex, 1-8, GR5	

Illustrated Parts List

OPTION - CURB ATTACHMENTS

STRIKE OFF PLATE OPTIONS

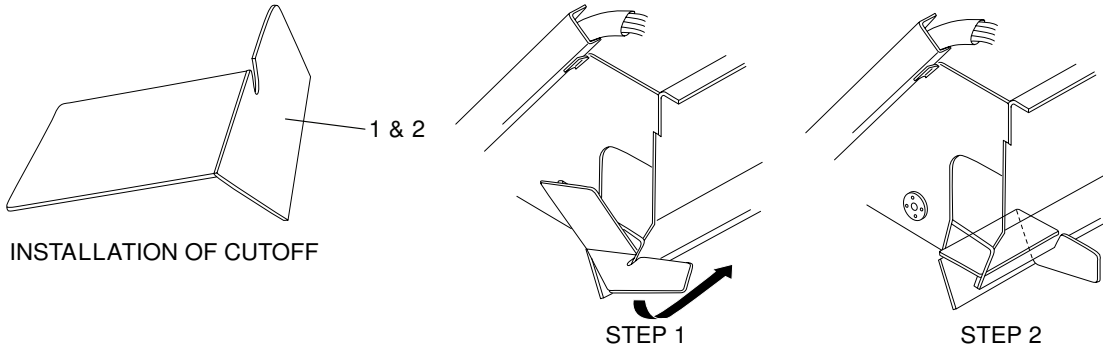

ROLL-UP CURB ATTACHMENT - 24"

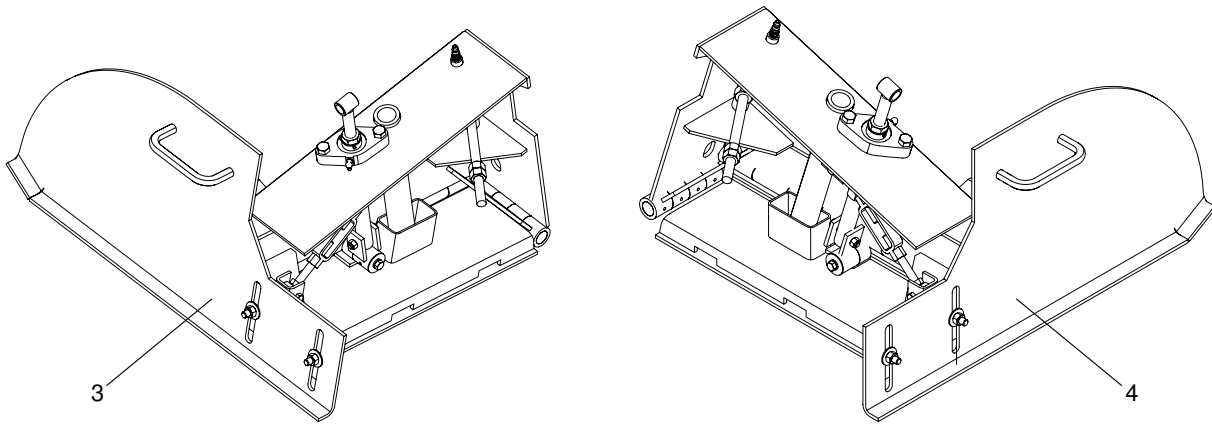

EXTENSION - 6"

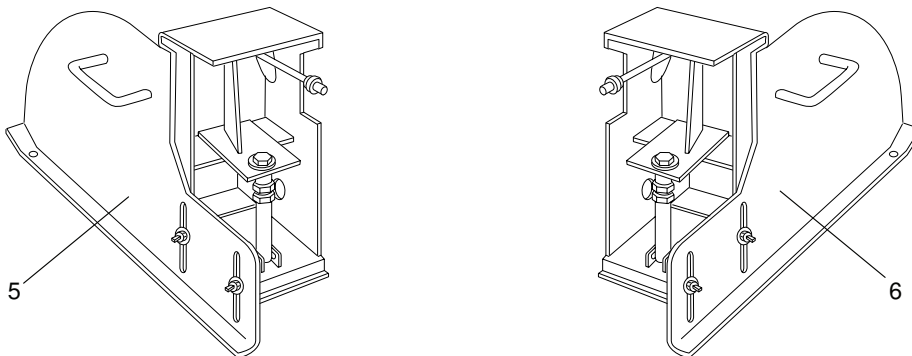

Figure 7-73. Option - Curb Attachments

Option - Curb Attachments

Item No	Part Number	Qty	Description	Remarks
1	860091LSRV	A/R	Strike Off, 12" (Left)	
2	860091RSRV	A/R	Strike Off, 12" (Right)	
REF	860095LSRV	A/R	Strike Off, 24" (Left)	Not Shown
REF	860095RSRV	A/R	Strike Off, 24" (Right)	Not Shown
3	851636LSRV	A/R	Roll Up Curb Attachment, 24" (Left)	Standard
4	851636RSRV	A/R	Roll Up Curb Attachment, 24" (Right)	Standard
REF	851635LSRV	A/R	Roll Up Curb Attachment, 12" (Left)	Not Shown
REF	851635RSRV	A/R	Roll Up Curb Attachment, 12" (Right)	Not Shown
5	851634LSRV	A/R	Extension, 6" (Left)	
6	851634RSRV	A/R	Extension, 6" (Right)	

Illustrated Parts List

OPTION - 20' PAVER LEVELING SKI ASSEMBLY

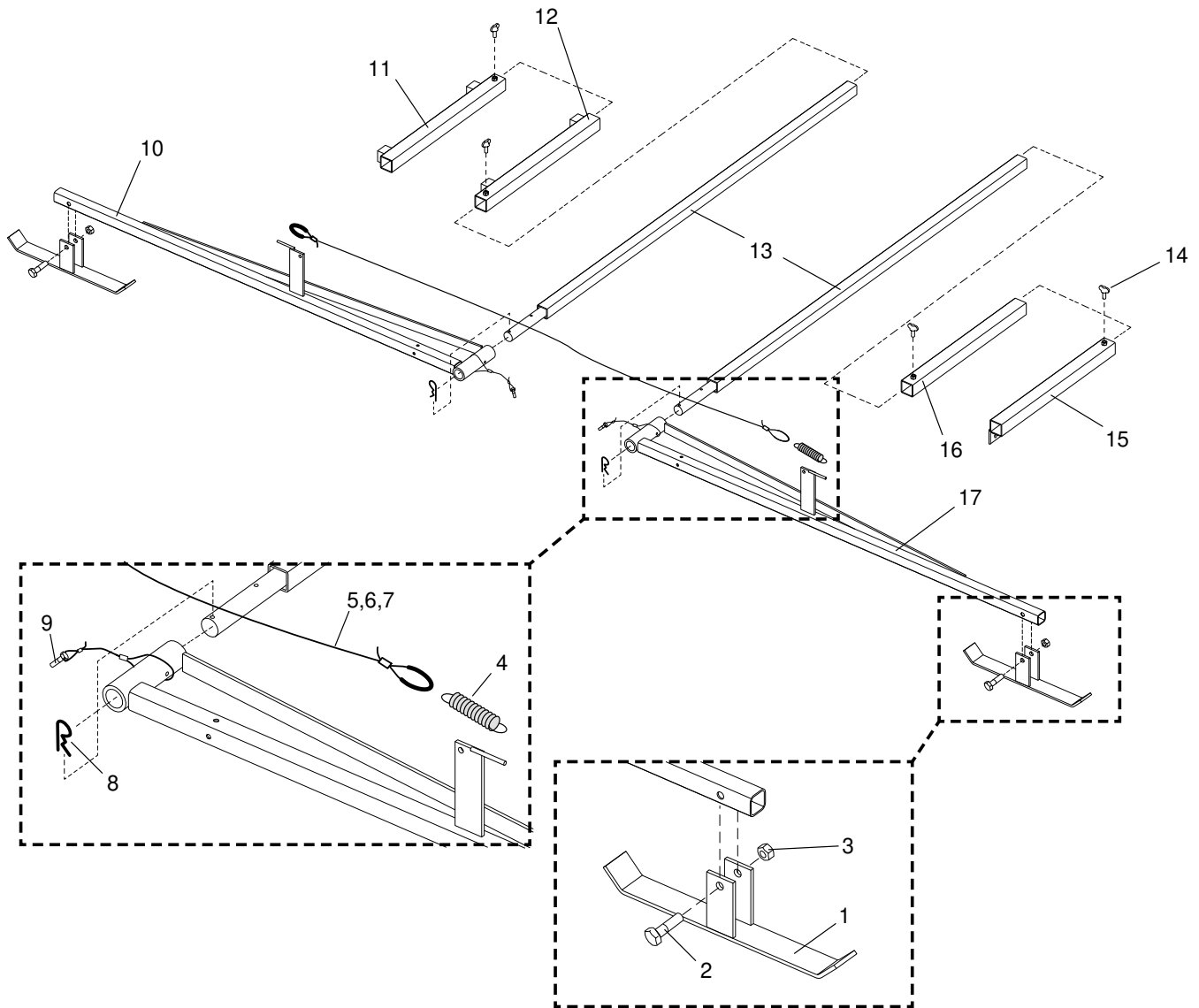

Figure 7-74. Option - 20' Paver Leveling Ski Assembly

Option - 20' Paver Leveling Ski Assembly

Item No	Part Number	Qty	Description	Remarks
GRP	851584SRV	GRP	Assembly, 20 Feet Ski	Complete Assembly
1	851249SRV	2	Skid	
2	100-6-16-40-5	2	Capscrew, Hex Head, 3/8-16 x 2.50	
3	204-6-16-5	3	Nut, Lock, Stover, 3/8-16	
4	851245	1	Spring, Extension	
5	851246	15	Cable, .063	
6	981981	6	Aluminum Cable Sleeve, 1/16"	
7	1013865	2	Thimble, Cable, .063	
8	870307	2	Hair Pin Clip, Clevis Pin	
9	1013870	2	Pin, Position Lock	
10	985190	1	Ski, 20', Front	
11	851243LSRV	1	Weldment, Front Slide Bar Housing	Left Side
12	851243RSRV	1	Weldment, Front Slide Bar Housing	Right Side
13	851242SRV	2	Bar, Adjustable Slide	
14	920070	4	Thumb Screw, 3/8-16 x 1.00	
15	851241RSRV	1	Weldment, Rear Slide Bar Housing	Right Side
16	851241LSRV	1	Weldment, Rear Slide Bar Housing	Left Side
17	985191	1	Ski, 20', Rear	

Illustrated Parts List

OPTION - 30'-40' PAVER LEVELING SKI ASSEMBLY

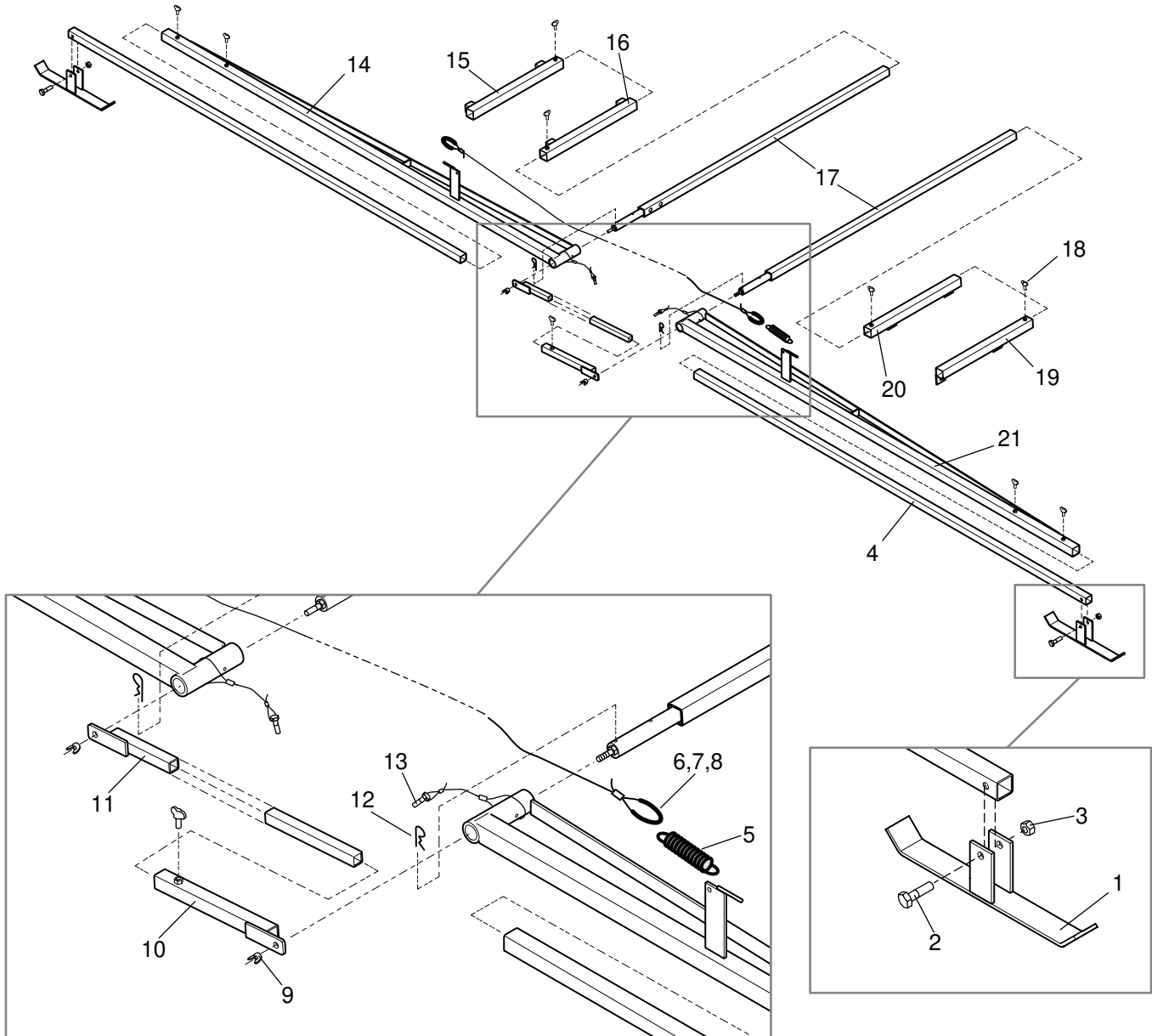

Figure 7-75. Option - 30' -40'Paver Leveling Ski Assembly

Option - 30'-40' Paver Leveling Ski Assembly

Item No	Part Number	Qty	Description	Remarks
GRP	851585SRV	GRP	30 - 40 Feet Ski Assembly	Complete Assembly
1	851249SRV	2	Weldment, Skid	
2	100-6-16-40-5	2	Capscrew, Hex Head, 3/8-16 x 2.50	
3	204-6-16-5	3	Nut, Lock, Stover, 3/8-16	
4	982005SRV	2	Tube, Ski Foot Mount	
5	851245	1	Spring, Extension	
6	851246	24	Cable, .063	
7	981981	6	Aluminum Cable Sleeve, 1/16"	
8	1013865	2	Thimble, Cable, .063	
9	212-6-16	2	Wing Nut, 3/8-16	
10	1002311	1	Weldment, Rear Brace, 40' Ski	
11	1002302	1	Weldment, Front Brace, 40' Ski	
12	870307	2	Hair Pin Clip, Clevis Pin	
13	1013870	2	Pin, Position Lock	
14	1002300	1	Weldment, Ski Support Front Arm, 40'	
15	851243LSRV	1	Weldment, Front Slide Bar Housing (Left)	Left Side
16	851243RSRV	1	Weldment, Front Slide Bar Housing (Right)	Right Side
17	1002305	2	Weldment, Adjustable Slide Bar	
18	920070	9	Thumb Screw, 3/8-16 x 1.00	
19	851241RSRV	1	Weldment, Rear Slide Bar Housing (Right)	Right Side
20	851241LSRV	1	Weldment, Rear Slide Bar Housing (Left)	Left Side
21	1002301	1	Weldment, Ski Support Rear Arm, 40'	

Illustrated Parts List

OPTION - TOPCON P-32 CONTROL ASSEMBLY

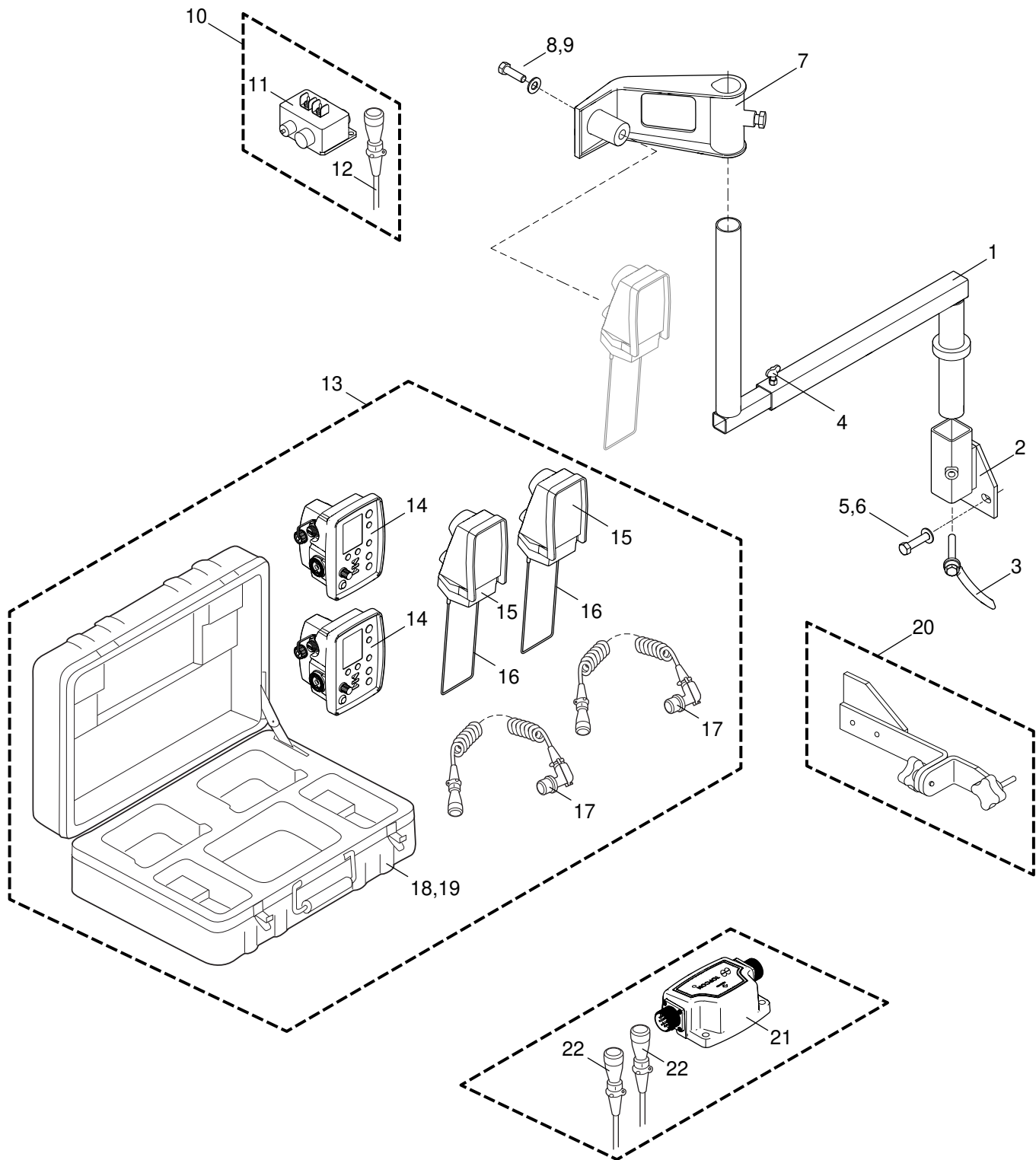

Figure 7-76. Option - TopCon P-32 Control Assembly

Option - TopCon P-32 Control Assembly

Item No	Part Number	Qty	Description	Remarks
GRP	1014912SRV		Option - TopCon P-32, Dual Grade	
1	9090-1125SRV	2	TopCon Z-Arm Bracket	
2	851575SRV	2	TopCon/Spectra Pivot Mount	
3	300060	2	Handle Nut, 5/8-11	
4	920070	6	Thumb Screw, 3/8-16 x 1.00	
5	100-10-11-20-5F	4	CSHH, 5/8-11 x 1.25, GR5, FT	
6	300-10	4	Washer, Flat, SAE, 5/8	
7	851578	2	TopCon Sonic Tracker Bracket	
8	100-12-10-64-8	2	CSHH, 3/4-10 x 4.00, GR8	
9	300-12	2	Washer, Flat, SAE, 3/4	
10	987053SRV	2	AM Module & Cable Assembly	Includes Items 11, 12
11	985866-01	2	AM Module Only	
12	985866-02	2	AM Module Cable Only	
13	1010499	1	TopCon P-32 Kit	Includes Items 14-19
14	1010499-08	2	GC-35 Controller Assembly	
15	1010499-06	2	Sonic Tracker II Assembly	
16	1010499-07	2	Temp Bail w/Sleeves Assembly	
17	1010499-04	2	GC-35/Sonic Tracker Cord Assembly (15 ft.)	
18	1010499-03	1	Carrying Case	
19	1010499-01	1	GC-35 Quick Reference Guide	Not Shown
20	1010499-05	2	GC-35 Paver Bracket Assembly	
REF	983416-01	2	Junction Box to Control Box Cable	Not Shown
REF	984596	2	Cable Remote Assembly	Not Shown
GRP	1014913SRV		Option - TopCon P-32 Dual Grade/Slope	Also Includes 1014912SRV
21	1010499-09	1	P-32 Slope Module	
22	1010499-10	2	Slope Module Cable (8 ft.)	
REF	1017796SRV	1	TopCon Grade Control Wiring Option	Not Shown

Illustrated Parts List

OPTION - TRUCK HITCH ASSEMBLY

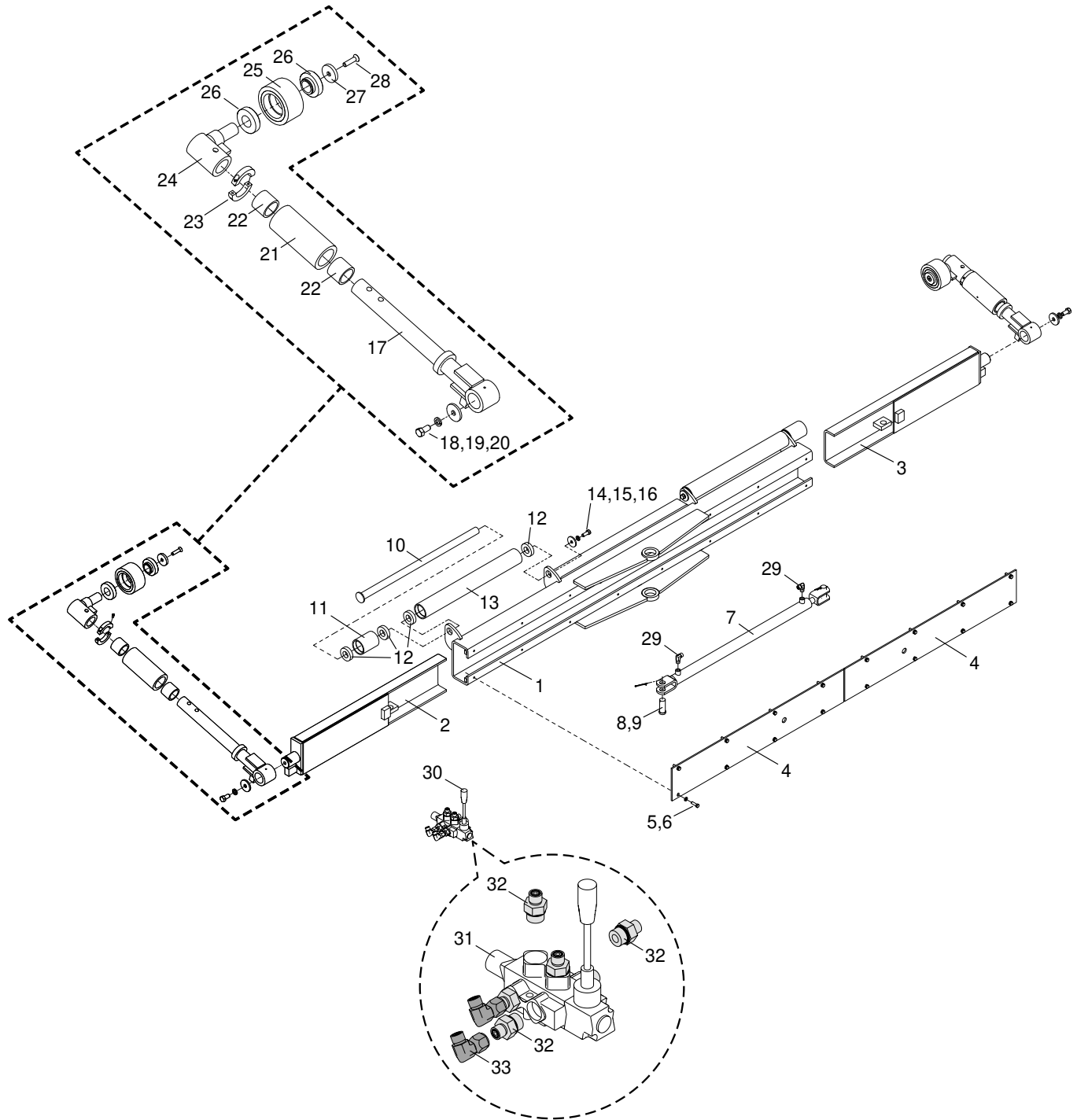

Figure 7-77. Option - Truck Hitch Assembly

Option - Truck Hitch Assembly

Item No	Part Number	Qty	Description	Remarks
OPT	1017214	1	Option - Truck Hitch	
REF	1008796	1	Truck Hitch Assembly w/Counter-Weight	Includes Items 1 - 29
1	930015	1	Pivotbar Support Weldment	
2	930025SRV	1	Truck Hitch Extension Arm - Left	
3	930020SRV	1	Truck Hitch Extension Arm - Right	
4	930065SRV	2	Truck Hitch Cover	
5	100-6-16-20-5	16	CSHH, 3/8-16 x 1.25, GR5	
6	302-6	16	Washer, Lock, 3/8	
REF	1019876	1	Truck Hitch Hydraulic Cylinder Assembly	Includes Items 7,29
7	930070	1	Hydraulic Cylinder, 1.50 x 30.00 x 1.00 Rod	
8	1000285	2	Clevis Pin, 1.00 x 2.50	
9	80338	2	Cotter Pin, .188 x 2.00	
10	930075	2	Truck Hitch Roller Assembly Shaft	
REF	930060	2	Tuck Hitch Roller Assembly	Includes Items 11, 12
11	856854	2	Round Tube	
12	810110	8	Push Roller Bearing, 1.250	
13	810102	2	Push Bar Roller Assembly w/Bearings	Includes Item 12
14	100-8-13-20-5F	2	CSHH, 1/2-13 x 1.25, GR5, FT	
15	302-8	2	Washer, Lock, 1/2	
16	855735	2	Flat Washer, .500 x 2.00 x .188	
17	930030SRV	2	Truck Hitch Wheel Weldment	
18	100-10-11-20-5F	2	CSHH, 5/8-11 x 1.25, GR5, FT	
19	302-10	2	Washer, Lock, 5/8	
20	856046	2	Flat Washer	
REF	930040	2	Round Tube Assembly	Includes Items 21, 22
21	856855	2	Round Tube	
22	810070	4	Bushing, 2.00	
23	620400	2	Locking Collar, 2.00	
24	930045SRV	2	Guide Wheel Axle Assembly	
25	930055	2	Guide Wheel Assembly	
26	930050	4	Radial Ball Bearing, 1.50	
27	851112	2	Washer	
28	104-406-1A	2	CSFH, 1/2-13 x 1.25, FT	
29	FS2501-06-06-FG	2	Elbow Adapter, 90°, -6 ORFS/-6 NPTF	
30	1017213	1	Truck Hitch Option - Valving Only	Includes Items 31-34
REF	1019168	1	Truck Hitch Valve Assembly w/Adapters	Includes Items 31-33
31	852250	1	Truck Hitch Valve	
32	FS6400-04-08-O	6	Straight Adapter, -4 ORFS/-8 O-Ring	
33	FS6500-04-04-FG	2	Swivel Elbow Adapter, 90°, -4 ORFS/-4 ORFS	
34	1019160	1	Truck Hitch Hose Kit	Not Shown

Illustrated Parts List

OPTION - UMBRELLA & FIRE EXTINGUISHERS

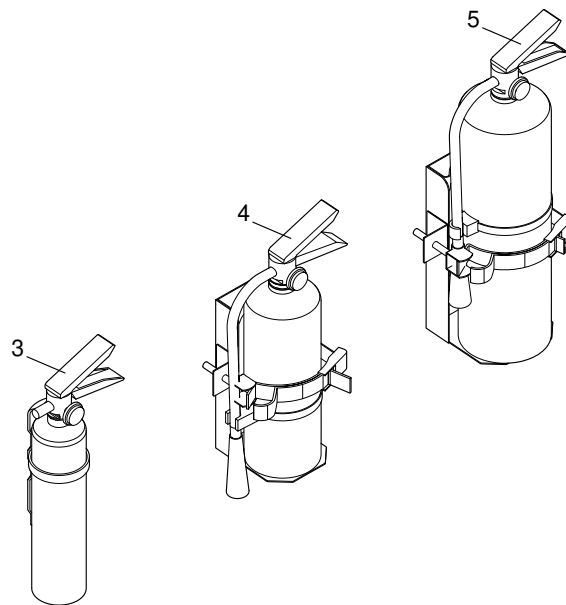
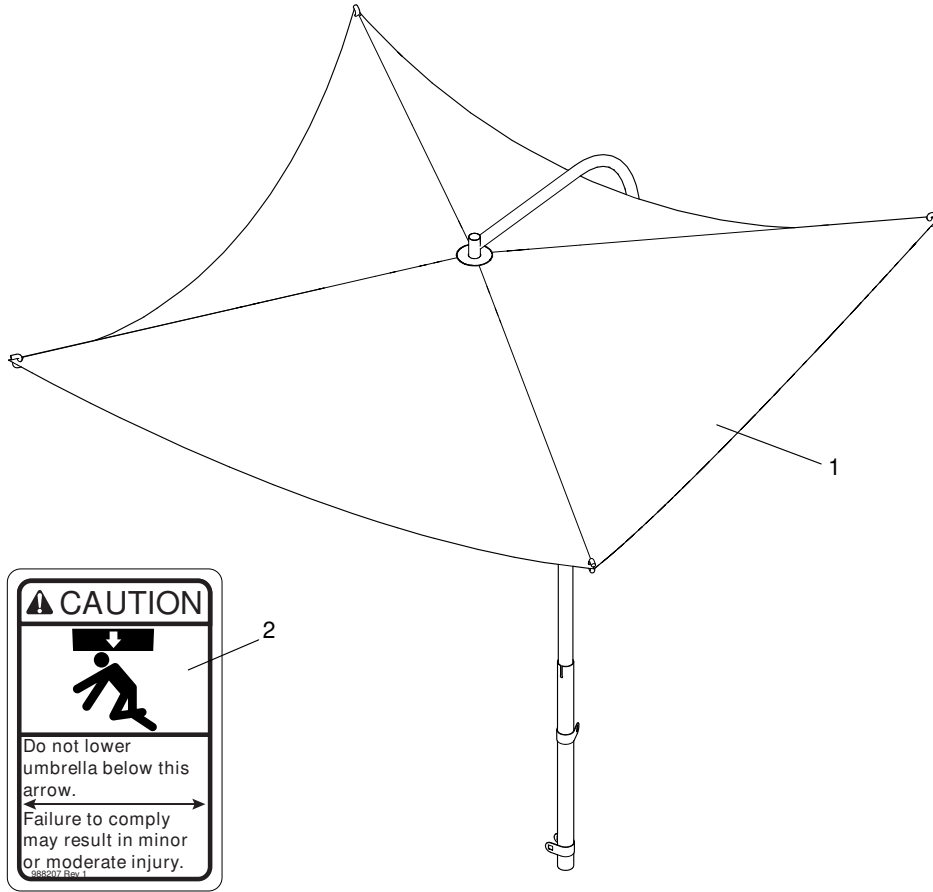

Figure 7-78. Option - Umbrella & Fire Extinguishers

Option - Umbrella & Fire Extinguishers

Item No	Part Number	Qty	Description	Remarks
OPT	988347SRV	1	Option - Umbrella w/Safety Decal	
1	920235	1	Umbrella w/Mounting Brackets	
2	988207	1	Decal - Umbrella	
3	360050	1	Option - Fire Extinguisher w/Bracket, 2.50 Lbs.	
4	982030	1	Option - Fire Extinguisher w/Bracket, 5 Lbs.	
REF	35828	1	Fire Extinguisher, 5 Lbs., 3A:40B:C	
REF	12313-5DC	1	Mounting Bracket, 5 Lbs. Fire Extinguisher	
5	982031	1	Option - Fire Extinguisher w/Bracket, 10 Lbs.	
REF	1014536	1	Fire Extinguisher, 10 Lbs., 4A:80B:c	
REF	12034-5HD	1	Mounting Bracket, 10 Lbs. Fire Extinguisher	

Illustrated Parts List

HYDRAULIC HOSE SCHEDULE - STANDARD UNIT

Hose No.	Qty.	Part Number	Description
GRP	1	1019156	8515E Main Hose Kit
1A	1	K811HTJCJC161616-72-SG-155-69.5	TANK TO PUMP R1 25.4 cc
1B	1	K811HTJCJC161616-70-SG-155-67.5	TANK TO PUMP F1 31.8cc
2	2	F387TCJCJ5080808-118-SG-084-115.75	RH CONVEYOR
3	2	F387TCJCJ5080808-16.5	LH CONVEYOR
4	1	F787TCJCJ9080808-74-SG-084-71.75	GEN PUMP TO LOWER MANIFOLD P3
5	1	F387TCJCJ9101010-99-SG-097-96.5	PUMP FO TO MANIFOLD GP2
7	1	K811HTJCJ9161616-37-SG-155-33.75	CONVEYOR PUMP SUCTION
8	1	F387TCJCJ1101010-63-SG-097-60.5	CONVEYOR PUMP TO MANIFOLD
9	1	F387TCJCJ7101010-47	CHARGE PUMP TO CHARGE FILTER IN TEE
10	1	F387TCJCJ9060606-110	RH WING
11	1	F387TCJCJ1060606-103	RH WING
12	1	F387TCJCJC060606-39.5	LH WING
13	1	F387TCJCJC060606-33	LH WING
14	2	F387TCJCJC060606-51	UPPER MANIFOLD TO WING BLOCK
15	1	F387TCJCJ7101010-60	CHARGE FILTER OUT TO PUMP
16A	1	F387TCJCJ9080808-40.5-AS-B-15-38.25	LH AUGER MOTOR
16B	1	F387TCJCJ9080808-39-AS-B-15-36.75	LH AUGER MOTOR
17	2	F387TCJCJ1080808-52.5-AS-B-15-50.25	RH AUGER MOTOR
20	1	K811HTJSJS242424-168	BOTTOM TANK TO TOP TANK
22	1	F387TCJCJ1060606-232	RH CUTOFF
23	1	F387TCJCJ9060606-234	RH CUTOFF
24	1	F387TCJCJ1060606-180	UPPER MANIFOLD TO CONVEYOR LIFT REAR PORT
25	1	F387TCJCJ9060606-192	UPPER MANIFOLD TO CONVEYOR LIFT FRONT PORT
26	1	F387TCJCJ1060606-202	LH CUTOFF
27	1	F387TCJCJ9060606-204	LH CUTOFF
28	1	F387TCJCJC060606-182	BOTTOM TANK TO TOP TANK VENT
29	1	F387TCJCJC040404-181	2SPD TO TEE
30	1	F487STJCJ5121212-169.5	LH DRIVE MOTOR A
31	1	F487STJCJ5121212-168.5	LH DRIVE MOTOR B
32	1	F487STJCJ5121212-174	RH DRIVE MOTOR B
33	1	F487STJCJ5121212-177.5	RH DRIVE MOTOR A
36	1	F387TCJCJ5121212-85-SG-113-81.75	PUMP CASE TO TOP OIL COOLER
42	1	F387TCJCJ9060606-42	LH SCREED LIFT LOWER TO UM S2
43	1	F387TCJCJC060606-113-SG-072-111.25	RH SCREED LIFT UPPER TO TEE
44	1	F387TCJCJC060606-121-SG-072-119.25	RH SCREED LIFT LOWER TO UM S1
45	1	F387TCJCJC060606-62	LH SCREED LIFT UPPER TO TEE
47	1	F387TCJCJ9121212-35	BOTTOM OIL COOLER TO TOP TANK

Illustrated Parts List

Hose No.	Qty.	Part Number	Description
49A	1	F387TCJCJ1060606-77	LH EXTENSION EXT
49B	1	F387TCJCJ9060606-75	LH EXTENSION RET
49C	1	F387TCJCJ1060606-77	RH EXTENSION EXT
49D	1	F387TCJCJ9060606-75	RH EXTENSION RET
51	1	F387TCJCJC060606-164	TT TO TRACK TENSION MANIFOLD
52	1	F387TCJCJC080808-14.5	LOWER MANIFOLD T2 TO TOP TANK
54	1	F387TCJCJ9080808-12	LOWER MANIFOLD T4 TO TOP TANK
55	1	F387TCJCJ1080808-214	LOWER MANIFOLD GEN TO GEN MOTOR REAR
56	1	F387TCJCJ9060606-21.5	GEN CASE DRAIN TO TANK
57	1	F387TCJCJC101010-15	GEN MOTOR FRONT PORT TO TANK
58	1	F387TCJCJ5101010-18	FILTER TO TOP MANIFOLD
59	1	F387TCJCJ7121212-71	T PORT CYL MANIFOLD TO TOP OIL COOLER
62	1	K811HTJCJ7161616-178	AUX COOLER RETURN TO BOTTOM TANK
71	1	F387TCJCJ9121212-212.5-AS-B-19-48	LOWER BULKHEAD TO AUX COOLER TEE
74	1	F387TCJCJC040404-169	BRAKE TO LOWER BULKHEAD
75	1	F387TCJCJ7121212-80	T PORT LOWER MANIFOLD TO TEE AUX COOLER
76	1	F387TCJCJ9040404-50	TEE AT CHARGE FILTER TO CC PORT LOWER MANIFOLD

Hose No.	Qty.	Part Number	Description
GRP	1	1019157	8515E Drive Motor Hose Kit
30	1	F487TCJCJ9121212-48	LH DRIVE FRONT PORT TO LH LOWER BULKHEAD
31	1	F487TCJCJ9121212-47	LH DRIVE REAR PORT TO LH UPPER BULKHEAD
32	1	F487TCJCJ9121212-27	RH DRIVE FRONT PORT TO RH LOWER BULKHEAD
33	1	F487TCJCJ9121212-28.5	RH DRIVE REAR PORT TO RH TOP BULKHEAD
67	1	F387TCJCJ9101010-52	LH CASE DRAIN TO BULKHEAD TEE
68	1	F387TCJCJC101010-30.5	RH CASE DRAIN TO BULKHEAD TEE
69	1	F387TCJCJC040404-38	RH BRAKE TO BULKHEAD TEE
70	1	F387TCJCJ9040404-40.25	RH TWO SPEED TO TEE
72	1	F387TCJCJC040404-14.25	LH TWO SPEED TO TEE
73	1	F387TCJCJ9040404-55	LH BRAKE TO BULKHEAD TEE

Hose No.	Qty.	Part Number	Description
GRP	1	1016860	8515E Track Tension Hose Kit
75		F387TC0639080808-42.5	TT MANIFOLD TO RH CYLINDER
76		F387TC0639080808-26	TT MANIFOLD TO LH CYLINDER

7

Illustrated Parts List

HYDRAULIC HOSE SCHEDULE - OPTIONS

Hose No.	Qty.	Part Number	Description
GRP	1	1015941	Sloping Screed Extension Hose Kit
L1	1	F387TC0606060606-97-AS-B-13-97	
L2	1	F387TC0606060606-133-AS-B-13-133	
R1	1	F387TC0606060606-104-AS-B-13-104	
R2	1	F387TC0606060606-140-AS-B-13-140	
Hose No.	Qty.	Part Number	Description
GRP	1	1017022	Berm Hose Kit
1	2	F387TC0341040404-59-AS-B-11-56.5	
2	2	F387TC0339040404-57.5-AS-B-11-55.25	
3	1	F387TC0606040604-97-AS-B-11-94.75	
4	1	F387TC0606040604-133-AS-B-11-130.75	
5		F387TC0606040604-104-AS-B-11-101.75	
6		F387TC0606040604-140-AS-B-11-137.75	
Hose No.	Qty.	Part Number	Description
GRP	1	1018494	Sloping Berm Hose Kit
100	1	F387TC0639040404-28-AS-B-11-26	SLOPE CYLINDER TO VALVE
101	1	F387TC0639040404-28-AS-B-11-26	SLOPE CYLINDER TO VALVE
102	1	F387TC0639040404-28-AS-B-11-26	SLOPE CYLINDER TO VALVE
103	1	F387TC0639040404-28-AS-B-11-26	SLOPE CYLINDER TO VALVE
104	1	F387TC0641040404-43-AS-B-11-40.75	OUTER BULKHEAD TO VALVE
105	1	F387TC0641040404-43-AS-B-11-40.75	OUTER BULKHEAD TO VALVE
106	1	F387TC0639040404-41-AS-B-11-39	INNER BULKHEAD TO VALVE
107	1	F387TC0639040404-41-AS-B-11-39	INNER BULKHEAD TO VALVE
108	1	F387TC0603060606-12-AS-B-13-9.5	LH SLOPE HOSE TO BERM VALVE
109	1	F387TC0603060606-12-AS-B-13-9.5	LH SLOPE HOSE TO BERM VALVE
Hose No.	Qty.	Part Number	Description
GRP	1	1015123	Power Crown Hose Kit
65	1	F387TC0639040404-115-AS-B-11-112	
66	1	F387TC0639040404-115-AS-B-11-112	

Illustrated Parts List

Hose No.	Qty.	Part Number	Description
GRP	1	1019160	Truck Hitch Hose Kit - Tractor
1	1	F387TCJCJ1040404-153	
2	1	F387TCJCJ9040404-147	
3	1	F387TCJCJC060606-37	
4	1	F387TCJCJC060606-37	

Hose No.	Qty.	Part Number	Description
GRP	1	1019161	Truck Hitch Hose Kit - Cylinder Side
1	1	F387TC0606040604-53.5-SG-060-51.25	
2	1	F387TC0606040604-53.5-SG-060-51.25	

Illustrated Parts List

DECAL SCHEDULE

Item	Qty.	Part Number	Description
KIT	1	1007678	DECAL KIT - SAFETY & OPERATIONS
	2	856443	DECAL, LEEBOY ADDRESS
	2	978800	DECAL, REFLECTIVE TAPE, 2" X 12"
	2	983607-14	DECAL, LEEBOY 9.75 X 4
	2	856441	DECAL, GUIDE BAR CAUTION
	4	940002	DECAL, FLAG, AMERICAN
	1	856454	DECAL, TOOLBOX, MAINT
	2	856472	DECAL, THICKER/THINNER
	1	856608	DECAL, RADIATOR
	1	856446	DECAL, CAUTION, HYDRAULIC FUEL ONLY
	1	856444	DECAL, EXPLOSION/FIRE HAZARD
	1	988634	DECAL, MANUAL BOXES
	1	856517	DECAL, BATTERY DISCONNECT
	1	856447	DECAL, BATTERY
	2	856442	DECAL, ENTANGLE HAZARD
	2	856456	DECAL, CHECK OIL EVERY 30 DAYS
	1	859781-03	DECAL, ENGINE OIL DRAIN
	2	1005474	DECAL, NO UNATTENDED
	2	1003164	DECAL, 8515B
	1	982176	DECAL, 8515, FUSE DIAGRAM
	1	859778	DECAL, UPPER & LOWER MANIFOLD
	2	73283-1	DECAL, WARNING, ENTANGLEMENT HAZARD
	1	856439	DECAL, OPER, CHECK LIST, FUSEBOX
	2	856437	DECAL, DANGER, PINCH POINT
	1	856455	DECAL, HOOD PROP
	1	856445	DECAL, WARNING OPERATOR
	1	986124-04	DECAL, PAVING PROFESSIONAL, RIGH
	1	986124-03	DECAL, DECO, WHITE RIGHT STRIPE ?EDWTPPIM?
	1	94004-21	PLATE, SERIAL NUMBER
	2	38077	REFLECTIVE TAPE, 1.50, RED/WHITE REFLECTIVE TAPE 1.5 RED/WHI
	2	859777	DECAL, EXT WIDTH
	1	859795	DECAL, CHECK ENGINE OIL DAILY
	1	856473	DECAL, MUST PLUG FUSE IN DASH BEFORE CONVEYOR WILL OPERATE
	1	1013275	DECAL, NOTICE, HYDRAULIC DYE
	1	1017808	DECAL, FILL LEVEL, HYDRAULIC OIL
	2	859764	DECAL, CAUTION, TRANSPORT LOCK

Illustrated Parts List

Item	Qty.	Part Number	Description
KIT	1	1016519	DECAL KIT - DECO
	1	1016519-01	DECAL, DECO, LEFT WING, 8515E
	1	1016519-02	DECAL, DECO, RIGHT WING, 8515E
	2	1016519-03	DECAL, DECO, 8515E, LEEBOY, VANDALISM/TOPBACK

Item	Qty.	Part Number	Description
KIT	1	1007677	DECAL KIT - HD SCREED
	2	859773	DECAL,ENTANGLEMENT HAZARD
	1	859799	DECAL,CAUTION,SONIC AUGERS,LH
	2	856476	DECAL,ENDGATE HEIGHT
	2	1007677-05	DECAL,HEAVY DUTY, SCREED
	2	1010489	DECAL,PINCH POINT,WEIGHT BLOCK,CYL
	2	1007677-01	DECAL, THICKER/THINNER, 816
	2	978800	DECAL,REFLECTIVE TAPE,2"X12"
	2	1007677-04	DECAL,FLIGHT SCREW RULER
	2	859789	DECAL,CAUTION,STEP
	1	1007677-06	DECAL,CROWN VALLEY
	1	859792	DECAL,WASH DOWN
	1	856483	DECAL,CAUTION,CROWN & VALLEY
	2	859777	DECAL,EXT WIDTH
	2	1007677-02	DECAL,EXTENSION ADJUSTMENTS
	2	859781-04	DECAL,TOOL BOX
	1	859801	DECAL,CAUTION,SONIC AUGERS,RH
	2	856482	CAUTION, FLIGHT SCREW HANDLE
	1	856484	DECAL,CAUTION,CROWN & VALLEY ADJUSTMENT
	2	1006199	DECAL, KEEP RODS CLEAN

Alphabetical Parts Index

ALPHABETICAL PARTS INDEX

Description	Part No.	Figure No.	Item No.
1/4 x 3/4 FB x 2-1/4 w/Hole	981487	7-50	25
12" Auger Extension Assembly - Left	985795SRV	7-71	REF
12" Auger Extension Assembly - Right	985796SRV	7-71	REF
12" Auger Flight - Left	981700L	7-71	1
12" Auger Flight - Right	981700R	7-71	2
12V Battery, 1150 CCA, Group# 31	Purchase Locally	7-14	17
12V Cigarette Lighter Receptacle	1011147	7-28	26
12V Cigarette Lighter Receptacle	1011147	7-29	24
12V Curly Cord	900082	7-49	5
12V DC Coil w/Deutsch Connector	1011728-02	7-21	5
12V DC Relay, SPST, 100A HD	985751	7-14	3
24" Auger Extension - Left	851230SRV	7-72	2
24" Auger Extension - Right	851229SRV	7-72	REF
24" Auger Extension Shield - Left	851228SRV	7-72	1
24" Auger Extension Shield - Right	851227SRV	7-72	REF
30 - 40 Feet Ski Assembly	851585SRV	7-75	GRP
45mm V-Guide Wheel	1007266	7-27	9
6 Way Electric Selector Valve	989656	7-44	21
90° Female Adapter Union NPTF / NPSM	1501-6-6	7-47	30
90° Female Adapter Union NPTF / NPSM	1501-6-6	7-48	30
90° Fitting, 06MP-06MP	853211085	7-44	11
90° Fitting, 06MP-06MP	853211085	7-67	11
-A-			
AC Detector, Generator Control	1017190	7-45	15
Access Door	1014584	7-7	16
Access Door - Left	1016467	7-17	11
Access Door Mount - Left	1016442	7-17	8
Access Door Mount Weldment - Right	1016434	7-18	7
Access Door Weldment - Right	1016431	7-18	10
Adapter, Connector, -6 JIC / -6 NPTF	2405-6-6	7-34	13
Adapter, Connector, -6 JIC / -6 NPTF	2405-6-6	7-35	13
Adjustable Roller Mount Plate	1016324	7-3	2
Adjuster Mount	1002715SRV	7-60	8
Adjuster Mount	1002715SRV	7-61	8
Adjuster Mount Plate	1015356	7-47	60
Adjuster Mount Plate	1015356	7-48	60
Adjuster Screw	1006431	7-41	19

Alphabetical Parts Index

Description	Part No.	Figure No.	Item No.
Adjuster Screw	1006431	7-50	44
Adjuster Screw Cap	1006434	7-41	2
Adjuster Screw Cap	1006434	7-50	1
Adjuster Sleeve w/Ball Joint	1006429	7-41	20
Adjuster Sleeve w/Ball Joint	1006429	7-50	45
Adjusting Swivel Nut Assembly	890070	7-65	10
Adjusting Swivel Nut Assembly	890070	7-66	10
Air Breather Assembly	1010255	7-13	3
Air Breather Mount Weldment	1011395	7-18	19
Air Inlet Hood, 3.75"	1002917-29	7-13	1
Alternator	1009253-21	7-13	10
Alternator Bracket	1009253-31	7-13	9
Aluminum Cable Sleeve, 1/16"	981981	7-74	6
Aluminum Cable Sleeve, 1/16"	981981	7-75	7
Aluminum Condulet Plug, 3/4	920238-5	7-49	13
Aluminum Condulet, 3/4	920238-2	7-49	10
Aluminum Dash Assembly	1007239	7-27	1
Aluminum Diamond Plate Step	985168	7-32	16
AM Module & Cable Assembly	987053SRV	7-76	10
AM Module Cable Only	985866-02	7-76	12
AM Module Only	985866-01	7-76	11
Amphenol Connector, 06-Pin Male	985687	7-45	11
AOA Adjuster Assembly	1006401	7-34	19
AOA Adjuster Assembly	1006401	7-35	19
AOA Adjuster Assembly	1006401	7-47	47
AOA Adjuster Assembly	1006401	7-48	47
Asphalt Blocker Plate - Upper	1015323	7-32	10
Assembly, 20 Feet Ski	851584SRV	7-74	GRP
ATM Blade Fuse, 20A	1017776-20	7-15	2
ATM Blade Fuse, 30A	1017776-30	7-15	4
ATM Blade Fuse, 5A	1017776-05	7-15	3
Auger Assembly w/Mount, 12" - Left	1019051	7-8	32L
Auger Assembly w/Mount, 12" - Right	1019052	7-8	32R
Auger Back Wear Plate, 12"	1016721	7-8	57
Auger Bearing	1007267	7-8	35
Auger Bearing Spacer Washer	1007323	7-8	34
Auger Clamp, 12"	1007269	7-8	21
Auger Cutoff Hydraulic Cylinder Assembly	1019174	7-25	REF
Auger End Mount - Long	1019053-01	7-8	44

7

Alphabetical Parts Index

Description	Part No.	Figure No.	Item No.
Auger End Mount Assembly - Long	1019053	7-8	REF
Auger Extension Shaft Weldment	985794	7-71	3
Auger Extension Support	851231SRV	7-72	5
Auger Flight, 12" - Left	981700L	7-8	39L
Auger Flight, 12" - Right	981700R	7-8	39R
Auger Motor Assembly	1017640	7-8	REF
Auger Motor Cover Assembly	981685	7-8	1
Auger Sensor	980540	7-42	20
Auger Sensor Cable	980550	7-42	21
Auger Shaft Collar	851645	7-8	41
Auger Shaft Spacer Assembly	1007306	7-8	36
Auger Spacer Tube	1019051-01	7-8	46
Auger Support Cover	981695SRV	7-8	6
Auxiliary Oil Cooler w/Fan	1019123	7-23	1
Auxiliary Oil Cooler w/Fan	1017837	7-23	REF
-B-			
Back Up Alarm, 107 dB	160320	7-30	7
Ball Valve - 3/8	480160	7-44	9
Ball Valve - 3/8	480160	7-67	9
Ball Valve, 1/4	20926564	7-25	13
Ball Valve, 1/4"	20926564	7-7	37
Ball Valve, 3/8	480160	7-19	23
Bar, .125 x 2.00 x 44.50, Notches	855562	7-56	13
Bar, .25 x 1.25 x 1.50 w/Hole	855759	7-32	15
Bar, .25 x 1.50 x 36	985120	7-34	10
Bar, .25 x 1.50 x 36	985120	7-35	10
Bar, .250 x 1.50 x 36	985120	7-58	10
Bar, .250 x 1.50 x 36	985120	7-59	10
Bar, .250 x 1.50 x 36	985120	7-60	12
Bar, .250 x 1.50 x 36	985120	7-61	12
Bar, .375 x 1.50 x 37.50	1016582	7-33	5
Bar, .375 x 1.50 x 42	985121	7-56	8
Bar, .375 x 1.50 x 42	985121	7-57	11
Bar, 1/4 x 1 x 5	855504	7-37	2
Bar, 1/4 x 1 x 5	855504	7-38	2
Bar, 1/4 x 1 x 5	855504	7-39	2
Bar, 1/4 x 1 x 5	855504	7-40	2
Bar, Adjustable Slide	851242SRV	7-74	13

Alphabetical Parts Index

Description	Part No.	Figure No.	Item No.
Battery Disconnect Switch	1009253-34	7-14	22
Battery Hold Down	72313	7-14	19
Battery Tray Pad	720130	7-14	18
Beacon Light Post Assembly	989469SRV	7-30	10
Beacon Light, LED Amber Strobe	1013231	7-30	12
Beacon Mount	1013234	7-30	11
Bearing	870030	7-68	7
Bearing Insert, Locking Set Screw	520060	7-6	5
Bearing Insert, Setscrew Locking	520060	7-5	3
Bent Axis Piston Motor, 10 CC	1014873-02	7-24	2
Berm Asphalt Blocker Plate - Left	1015372	7-47	36
Berm Asphalt Blocker Plate - Right	1015348	7-48	36
Berm Extension Assembly - Left	1015425	7-47	REF
Berm Extension Assembly - Right	1015413	7-48	REF
Berm Extension Weldment - Left	1015426	7-47	1
Berm Extension Weldment - Right	1015414	7-48	1
Berm Height Indicator Bar	1015361	7-47	18
Berm Height Indicator Bar	1015361	7-48	18
Berm Height Linkage Plate	1015360	7-47	20
Berm Height Linkage Plate	1015360	7-48	20
Berm Hydraulic Cylinder	1015349	7-47	22
Berm Hydraulic Cylinder	1015349	7-48	22
Berm Lid Heat Box Weldment - Left	1015434	7-47	35
Berm Lid Heat Box Weldment - Right	1015422	7-48	35
Bolt-On Asphalt Shield	1014028	7-32	17
Bolt-On Asphalt Shield Plate	1015171	7-32	18
Bolt-On Upper Asphalt Shield Plate	1015172	7-32	25
Bottom Rail Bar	981658	7-57	16
Branch Tee Adapter, -10 ORFS/ -10 ORFS/ -12 O-Ring	FS6803-10-10-12-NWO-FG	7-16	18
Bulkhead Lock Nut, -12 ORFS	FS0306-12	7-1	49
Bulkhead Lock Nut, -12 ORFS	FS0306-12	7-2	36
Bulkhead Lock Nut, -4 ORFS	FS0306-04	7-1	51
Bulkhead Lock Nut, -4 ORFS	FS0306-04	7-2	38
Bulkhead Lock Nut, -6 ORFS	FS0306-06	7-33	17
Bulkhead to Generator Harness	1016724	7-24	REF
Bulkhead to Generator Harness	1016724	7-28	REF
Bulkhead to Generator Harness	1016724	7-29	REF
Bulkhead Union Adapter, -10 JIC/-10 JIC	2700-10-10-LN	7-53	34
Bulkhead Union Adapter, -12 ORFS/-12 ORFS	FS2700-12-12	7-1	48

Alphabetical Parts Index

Description	Part No.	Figure No.	Item No.
Bulkhead Union Adapter, -12 ORFS/-12 ORFS	FS2700-12-12	7-2	35
Bulkhead Union Adapter, -6 ORFS/-6 ORFS	FS2700-06-06	7-33	16
Bushing	988588	7-62	4
Bushing, 2.00	810070	7-77	22
Bushing, 2.00 ID x 2.50 OD x 2.50	810070	7-8	43
-C-			
Cable Remote Assembly	984596	7-76	REF
Cable, .063	851246	7-74	5
Cable, .063	851246	7-75	6
Cap Adapter, -10 ORFS	FS304-C-10	7-16	19
Capscrew, Hex Head, 3/8-16 x 2.50	100-6-16-40-5	7-74	2
Capscrew, Hex Head, 3/8-16 x 2.50	100-6-16-40-5	7-75	2
Carrying Case	1010499-03	7-76	18
Cartridge Relief Valve	1015402-04	7-22	18
Cast Steel Track Pad	811304	7-1	56
Center Flashin	985063	7-7	21
Center Hood Weldment	1016421	7-17	1
Chain Coupling Sprocket Half w/Hole	854003	7-72	3
Chain Cover	981688SRV	7-8	52
Chain Shield	986643	7-68	6
Chain, 40 Roller	986639SRV	7-68	3
Chain, Roller, 40 x 52 Pitch	870190	7-57	4
Charge Filter Assembly	1018912	7-25	REF
Check Valve, 140 PSI, -8 ORFS/10 O-Ring	1019784	7-8	59
Chrome Rod	988601	7-62	6
Circuit Breaker Boot	1016892	7-45	9
Circuit Breaker, 10A	1009228	7-45	7
Circuit Breaker, 10A w/Mount	986546	7-28	42
Circuit Breaker, 10A w/Mount	986546	7-29	40
Circuit Breaker, 15A, Pan Mount	985140	7-45	6
Circuit Breaker, 40A, Generator Protection	1016901	7-45	16
Circuit Breaker, 50A	1017057	7-24	15
Circular LED Light w/Deutsch Connector	1013307	7-30	8
Citrus Tank Assembly	1006552SRV	7-44	1
Clevis Pin	1016711-4	7-25	22
Clevis Pin, .750 x 2.00	37662	7-47	23
Clevis Pin, .750 x 2.00	37662	7-48	23
Clevis Pin, 1.00 x 2.50	1011476	7-25	10

Alphabetical Parts Index

Description	Part No.	Figure No.	Item No.
Clevis Pin, 1.00 x 2.50	1000285	7-77	8
Clevis Pin, 1.00 x 2.50	1011476	7-7	13
Clevis Pin, 1.00 x 3.25 w/1.50 Head	240030	7-8	11
Clevis Pin,ø1.00 x 2.50	1000285	7-25	21
Clevis, 1/4-28	350050	7-20	10
Coil Cord, 6s/6s 1.5 to 7.5 FT	983050	7-65	15
Coil Cord, 6s/6s 1.5 to 7.5 FT	983050	7-66	15
Coil, 4303212	1000825-01	7-22	27
Coil, 4303612	1006953-15	7-22	25
Coil, 4303712	1002070-01	7-22	21
Column Height Adjustment Pin	1017374	7-27	27
Conduit Lock Nut, 1/2	LN1010	7-49	4
Conduit Lock Nut, 3/4 NPT	38965	7-24	8
Condulet Aluminum Plug, 3/4"	920238-5	7-53	24
Condulet Box Gasket, 3/4	920238-4	7-49	8
Condulet Box Gasket, 3/4"	920238-4	7-53	22
Condulet Cover, 3/4	920238-3	7-49	7
Condulet Cover, 3/4"	920238-3	7-53	21
Condulet, Aluminum, 3/4"	920238-2	7-53	23
Connector Adapter, -10 ORFS/- 8 NPTF	FS2404-10-8	7-2	7
Connector Adapter, -10 ORFS/-8 NPTF	FS2404-10-08	7-1	7
Connector Adapter, -6 JIC / -6 NPTF	2404-6-6	7-19	24
Connector Adapter, -6 JIC / -6 NPTF	2405-6-6	7-47	31
Connector Adapter, -6 JIC / -6 NPTF	2405-6-6	7-48	31
Connector Adapter, -6 ORFS/-4 NPTF	FS2404-06-04	7-25	14
Connector Lockwasher, HDP20 Series	1011855	7-28	24
Connector Lockwasher, HDP20 Series	1011855	7-29	22
Connector Nut, HDP20 Series	1011854	7-28	23
Connector Nut, HDP20 Series	1011854	7-29	21
Connector, 3 Pin, DT06-3S-EP11	1000649	7-28	38
Connector, 3 Pin, DT06-3S-EP11	1000649	7-29	36
Connector, 3 Pin, Panel Mount, DT04-3P	1010657	7-28	28
Connector, 3 Pin, Plug	989179	7-28	27
Connector, 3 Pin, Plug	983210	7-28	39
Connector, 3 Pin, Plug	983210	7-29	37
Connector, 3 Pin, Y Socket	989178	7-28	37
Connector, 3 Pin, Y Socket	989178	7-29	35
Connector, 31 Pin, HD34-24-31ST	1015381	7-28	19
Connector, 31 Pin, HD34-24-31ST	1015381	7-29	17

7

Alphabetical Parts Index

Description	Part No.	Figure No.	Item No.
Connector, 31 Pin, HD34-24-31ST	1015381	7-39	21
Connector, 31 Pin, HD34-24-31ST	1015381	7-40	20
Connector, Water-Tight, 1/2 x 1/2 MPT	3200DI	7-69	5
Continuous Rubber Track	982585	7-2	1
Control Box Assembly	1016576	7-26	1
Control Box Assembly	1016576	7-28	GRP
Control Box Assembly	1018700	7-29	GRP
Control Box Assembly, 10kW	1016891	7-45	REF
Control Box Enclosure	1016034-01	7-28	1
Control Box Enclosure	1017810	7-29	1
Control Box Mounting Plate	1017746	7-69	6
Conveyor Automatic Micro Switch	900050SRV	7-6	37
Conveyor Bottom Pan - Left	851127LSRV	7-4	REF
Conveyor Bottom Pan - Right	851127RSRV	7-4	REF
Conveyor Bumper	410070	7-5	8
Conveyor Center Cover	851133SRV	7-4	15
Conveyor Center Rear Rubber	840162	7-4	22
Conveyor Center Weld Plate	802114	7-4	23
Conveyor Chain Assembly w/Clean Out Bars	1016941SRV	7-5	10
Conveyor Chain Block Link	850080	7-5	16
Conveyor Chain Guard Weldment - Left	1019047SRV	7-6	13
Conveyor Chain Guard Weldment - Right	1019048SRV	7-6	14
Conveyor Chain Idler Roller	850162	7-5	7
Conveyor Chain Link w/Tab	850080B	7-5	12
Conveyor Chain Master Link	850070A	7-5	14
Conveyor Chain Offset Link	850215A	7-5	REF
Conveyor Chain T-Pin	850100A	7-5	15
Conveyor Cutoff Assembly - Left	1016523SRV	7-6	28
Conveyor Cutoff Assembly - Right	1016524SRV	7-6	38
Conveyor Cutoff Flap Weldment - Left	1016521	7-6	30
Conveyor Cutoff Flap Weldment - Right	1016526	7-6	40
Conveyor Cutoff Hinge Weldment - Left	1016522	7-6	29
Conveyor Cutoff Hinge Weldment - Right	1016525	7-6	39
Conveyor Drive Motor Sprocket	851120	7-6	18
Conveyor Drive Shaft	851116	7-6	4
Conveyor Drive Shaft Snap Ring	850040	7-5	5
Conveyor Drive Shaft Snap Ring	850040	7-6	7
Conveyor Drive Sprocket	1019092	7-6	11
Conveyor Drive Sprocket Washer	851112	7-6	10

Alphabetical Parts Index

Description	Part No.	Figure No.	Item No.
Conveyor Drive Tension Adjuster Weldment	1014196	7-6	22
Conveyor Flap Hinge Pin - Left	1015297	7-6	31
Conveyor Flap Hinge Pin - Right	1015298	7-6	41
Conveyor Flight Chain Bar	851118A	7-5	11a
Conveyor Flight Clean Out Bar	1014959	7-5	11b
Conveyor Floor Plate	851627SRV	7-5	REF
Conveyor Front Guide Tube Assembly	851123	7-5	1
Conveyor Front Guide Wheel	850120	7-5	4
Conveyor Idler Shaft	851124	7-5	2
Conveyor Lift Cylinder, 3.00 x 9.00	1016711	7-25	19
Conveyor Lift Hydraulic Cylinder Assembly	1019171	7-25	REF
Conveyor Pan, Front - Left	855882	7-4	30
Conveyor Pan, Front - Right	855879	7-4	26
Conveyor Pan, Rear - Left	855881	7-4	29
Conveyor Pan, Rear - Right	855878	7-4	25
Conveyor Plate Washer	855346	7-4	10
Conveyor Switch Arm	900060-1SRV	7-6	35
Conveyor Switch Linkage, Rod	900075	7-6	36
Conveyor Tube Assembly	851651	7-6	3
Coolant Recovery Tank	986537-46	7-12	13
Cooler Mount Weldment - Top	1016567	7-23	2
Cooler Mounting Brace	1016708	7-23	4
Cotter Pin, .148, #9	5928	7-47	24
Cotter Pin, .148, #9	5928	7-48	24
Cotter Pin, .177, 7 GA	870307	7-1	9
Cotter Pin, .177, 7 GA	870307	7-2	9
Cotter Pin, .188 x 1.50	80336	7-7	14
Cotter Pin, .188 x 2.00	80338	7-8	12
Cotter Pin, .188 x 2.00	80338	7-77	9
Cotter Pin, 1/16 x 3/4 Plated	13A-0212ZI	7-6	34
Cotter Pin, 3/16" x 1-1/2"	80336	7-25	11
Cover	986644	7-68	5
Cover Connector Weldment	1016404	7-18	5
CR Shaft, ø1.00 x 4.50	855579	7-42	11
CR Shaft, ø1.00 x 4.50	855579	7-51	15
CR Shaft, ø1.00 x 4.50	855579	7-52	21
Crown & Valley Assembly	1009439	7-33	20
Crown & Valley Assembly - Front	870172	7-56	3
Crown & Valley Assembly - Front	870172	7-57	3

7

Alphabetical Parts Index

Description	Part No.	Figure No.	Item No.
Crown & Valley Assembly - Rear	870182	7-56	2
Crown & Valley Assembly - Rear	870182	7-57	2
Crown & Valley Gauge Assembly	1006637	7-68	12
Crown & Valley Gauge Bar	1007232	7-32	27
Crown & Valley Locking Bar	988376	7-56	5
Crown & Valley Rear Assembly	1009609	7-53	19
Crown & Valley Turnbuckle Assembly	1009440	7-33	21
Crown & Valley Turnbuckle Assembly	1009614	7-53	18
Crown Adjust Mount	854491	7-68	11
Crown And Valley Locking Bar	988376	7-57	5
Crown Frame	986645	7-68	4
Crown Mounting Spacer	1006419	7-33	22
CSFH, 1/2-13 x 1.25, FT	104-406-1A	7-77	28
CSFHS, 1/2-13 x .75, FT	105-8-13-12-F	7-42	4
CSFHS, 1/2-13 x .75, FT	105-8-13-12-F	7-51	4
CSFHS, 1/2-13 x 1.00, FT	105-8-13-16-F	7-6	9
CSFHS, 1/2-13 x 1.50, FT	105-8-13-24-F	7-4	17
CSFHS, 1/2-13 x 2.00, GR5, FT	105-8-13-32-F	7-6	24
CSFHS, 1/4-20 x .75, FT	105-4-20-12-F	7-47	41
CSFHS, 1/4-20 x .75, FT	105-4-20-12-F	7-48	41
CSFHS, 3/8-16 x .75, FT	105-6-16-12-F	7-4	18
CSFHS, 3/8-16 x 1.50, FT	105-6-16-24-F	7-47	37
CSFHS, 3/8-16 x 1.50, FT	105-6-16-24-F	7-48	37
CSFHS, 5/8-11 x .875, FT	105-10-11-14-F	7-4	24
CSFHS, 5/8-11 x 2.00, FT	105-10-11-32-F	7-4	11
CSHH, 1/2-13 x .75, GR5, FT	100-8-13-12-5F	7-65	9
CSHH, 1/2-13 x .75, GR5, FT	100-8-13-12-5F	7-66	9
CSHH, 1/2-13 x 1.00, GR5, FT	100-8-13-16-5F	7-6	42
CSHH, 1/2-13 x 1.00, GR5, FT	100-8-13-16-5F	7-53	14
CSHH, 1/2-13 x 1.25, GR5, FT	100-8-13-20-5F	7-4	4
CSHH, 1/2-13 x 1.25, GR5, FT	100-8-13-20-5F	7-43	11
CSHH, 1/2-13 x 1.25, GR5, FT	100-8-13-20-5F	7-77	14
CSHH, 1/2-13 x 1.375, GR5	100-8-13-22-5	7-8	5
CSHH, 1/2-13 x 1.50, GR5	100-8-13-24-5	7-3	14
CSHH, 1/2-13 x 1.50, GR5	100-8-13-24-5	7-8	47
CSHH, 1/2-13 x 1.50, GR5	100-8-13-24-5	7-23	13
CSHH, 1/2-13 x 1.50, GR5	100-8-13-24-5	7-27	19
CSHH, 1/2-13 x 1.50, GR5	100-8-13-28-5	7-34	36
CSHH, 1/2-13 x 1.50, GR5	100-8-13-28-5	7-35	36

Alphabetical Parts Index

Description	Part No.	Figure No.	Item No.
CSHH, 1/2-13 x 1.50, GR5	100-8-13-24-5	7-53	17
CSHH, 1/2-13 x 1.50, GR8	100-8-13-24-8	7-13	23
CSHH, 1/2-13 x 1.75, GR5	100-8-13-28-5	7-47	51
CSHH, 1/2-13 x 1.75, GR5	100-8-13-28-5	7-48	51
CSHH, 1/2-13 x 2.00, GR5	100-8-13-32-5	7-8	15
CSHH, 1/2-13 x 2.00, GR5	100-8-13-32-5	7-43	6
CSHH, 1/2-13 x 2.00, GR5	100-8-13-32-5	7-47	12
CSHH, 1/2-13 x 2.00, GR5	100-8-13-32-5	7-48	12
CSHH, 1/2-13 x 2.50, GR5	100-8-13-40-5	7-7	30
CSHH, 1/2-13 x 2.50, GR5	100-8-13-40-5	7-20	23
CSHH, 1/2-13 x 2.50, GR5	100-8-13-40-5	7-34	32
CSHH, 1/2-13 x 2.50, GR5	100-8-13-40-5	7-35	32
CSHH, 1/2-20 x 1.00, GR5, FT	100-8-20-16-5F	7-8	56
CSHH, 1/2-20 x 1.50, GR5	100-8-20-24-5	7-62	9
CSHH, 1/4-20 x .75, GR5, FT	100-4-20-12-5F	7-19	28
CSHH, 1/4-20 x .75, GR5, FT	100-4-20-12-5F	7-26	20
CSHH, 1/4-20 x .75, GR5, FT	100-4-20-12-5F	7-27	3
CSHH, 1/4-20 x .75, GR5, FT	100-4-20-12-5F	7-41	3
CSHH, 1/4-20 x .75, GR5, FT	100-4-20-12-5F	7-45	19
CSHH, 1/4-20 x .75, GR5, FT	100-4-20-12-5F	7-50	2
CSHH, 1/4-20 x .75, GR5, FT	100-4-20-12-5F	7-69	10
CSHH, 1/4-20 x .875, GR5	100-4-20-14-5	7-44	17
CSHH, 1/4-20 x .875, GR5	100-4-20-14-5	7-67	17
CSHH, 1/4-20 x 1.00, GR5, FT	100-4-20-16-5F	7-6	19
CSHH, 1/4-20 x 1.00, GR5, FT	100-4-20-16-5F	7-26	14
CSHH, 1/4-20 x 1.00, GR5, FT	100-4-20-16-5F	7-60	19
CSHH, 1/4-20 x 1.00, GR5, FT	100-4-20-16-5F	7-61	19
CSHH, 1/4-20 x 1.25, GR5	100-4-20-20-5	7-20	11
CSHH, 1/4-20 x 1.50, GR5	100-4-20-24-5	7-43	3
CSHH, 1/4-20 x 2.50, GR5	100-4-20-40-5	7-27	21
CSHH, 1-8 x 2.50, GR5	100-16-8-40-5	7-20	4
CSHH, 3/4-10 x 2.25, GR5	100-12-10-36-5	7-50	46
CSHH, 3/4-10 x 4.00, GR8	100-12-10-64-8	7-76	8
CSHH, 3/8-16 x .625, GR5, FT	100-6-16-10-5F	7-6	15
CSHH, 3/8-16 x .75, GR5, FT	100-6-16-12-5F	7-3	16
CSHH, 3/8-16 x .75, GR5, FT	100-6-16-12-5F	7-12	19
CSHH, 3/8-16 x .75, GR5, FT	100-6-16-12-5F	7-17	13
CSHH, 3/8-16 x .75, GR5, FT	100-6-16-12-5F	7-18	12
CSHH, 3/8-16 x .75, GR5, FT	100-6-16-12-5F	7-32	19

Alphabetical Parts Index

Description	Part No.	Figure No.	Item No.
CSHH, 3/8-16 x .75, GR5, FT	100-6-16-12-5F	7-34	5
CSHH, 3/8-16 x .75, GR5, FT	100-6-16-12-5F	7-35	5
CSHH, 3/8-16 x .75, GR5, FT	100-6-16-12-5F	7-42	17
CSHH, 3/8-16 x .75, GR5, FT	100-6-16-12-5F	7-47	29
CSHH, 3/8-16 x .75, GR5, FT	100-6-16-12-5F	7-48	29
CSHH, 3/8-16 x .75, GR5, FT	100-6-16-12-5F	7-51	22
CSHH, 3/8-16 x .75, GR5, FT	100-6-16-12-5F	7-52	27
CSHH, 3/8-16 x 1.00, GR5, FT	100-6-16-16-5F	7-6	32
CSHH, 3/8-16 x 1.00, GR5, FT	100-6-16-16-5F	7-8	53
CSHH, 3/8-16 x 1.00, GR5, FT	100-6-16-16-5F	7-12	17
CSHH, 3/8-16 x 1.00, GR5, FT	100-6-16-16-5F	7-20	14
CSHH, 3/8-16 x 1.00, GR5, FT	100-6-16-16-5F	7-23	10
CSHH, 3/8-16 x 1.00, GR5, FT	100-6-16-16-5F	7-26	11
CSHH, 3/8-16 x 1.00, GR5, FT	100-6-16-16-5F	7-34	15
CSHH, 3/8-16 x 1.00, GR5, FT	100-6-16-16-5F	7-35	15
CSHH, 3/8-16 x 1.00, GR5, FT	100-6-16-16-5F	7-37	6
CSHH, 3/8-16 x 1.00, GR5, FT	100-6-16-16-5F	7-38	6
CSHH, 3/8-16 x 1.00, GR5, FT	100-6-16-16-5F	7-52	6
CSHH, 3/8-16 x 1.00, GR5, FT	100-6-16-16-5F	7-53	2
CSHH, 3/8-16 x 1.00, GR5, FT	100-6-16-16-5F	7-63	6
CSHH, 3/8-16 x 1.00, GR5, FT	100-6-16-16-5F	7-64	6
CSHH, 3/8-16 x 1.25, GR5	100-6-16-20-5	7-7	29
CSHH, 3/8-16 x 1.25, GR5	100-6-16-20-5	7-24	9
CSHH, 3/8-16 x 1.25, GR5	100-6-16-20-5	7-47	21
CSHH, 3/8-16 x 1.25, GR5	100-6-16-20-5	7-48	21
CSHH, 3/8-16 x 1.25, GR5	100-6-16-20-5	7-50	16
CSHH, 3/8-16 x 1.25, GR5	100-6-16-20-5	7-77	5
CSHH, 3/8-16 x 1.25, GR5, FT	100-6-16-20-5F	7-4	35
CSHH, 3/8-16 x 1.375, GR5	100-6-16-22-5	7-50	21
CSHH, 3/8-16 x 1.50, GR5, FT	100-6-16-24-5F	7-4	31
CSHH, 3/8-16 x 1.50, GR5, FT	100-6-16-24-5F	7-42	6
CSHH, 3/8-16 x 1.50, GR5, FT	100-6-16-24-5F	7-51	10
CSHH, 3/8-16 x 1.50, GR5, FT	100-6-16-24-5F	7-52	17
CSHH, 3/8-16 x 1.625, GR5, FT	100-6-16-26-5F	7-7	9
CSHH, 3/8-16 x 1.63, GR5	100-6-16-26-5	7-26	18
CSHH, 3/8-16 x 1.75, GR5	100-6-16-28-5	7-63	18
CSHH, 3/8-16 x 1.75, GR5	100-6-16-28-5	7-64	18
CSHH, 3/8-16 x 10.00, GR5	100-6-16-160-5	7-14	20
CSHH, 3/8-16 x 2.00, GR5	100-6-16-32-5	7-12	15

Alphabetical Parts Index

Description	Part No.	Figure No.	Item No.
CSHH, 3/8-16 x 2.00, GR5	100-6-16-32-5	7-32	22
CSHH, 3/8-16 x 2.00, GR5	100-6-16-32-5	7-60	16
CSHH, 3/8-16 x 2.00, GR5	100-6-16-32-5	7-61	16
CSHH, 3/8-16 x 2.25, GR5	100-6-16-36-5	7-39	11
CSHH, 3/8-16 x 2.25, GR5	100-6-16-36-5	7-40	11
CSHH, 3/8-16 x 2.50, GR5	100-6-16-40-5	7-39	8
CSHH, 3/8-16 x 2.50, GR5	100-6-16-40-5	7-40	8
CSHH, 3/8-24 x .75, GR5, FT	100-6-24-12-5F	7-34	27
CSHH, 3/8-24 x .75, GR5, FT	100-6-24-12-5F	7-35	27
CSHH, 3/8-24 x 1.00, GR5, FT	100-6-24-16-5F	7-34	7
CSHH, 3/8-24 x 1.00, GR5, FT	100-6-24-16-5F	7-35	7
CSHH, 3/8-24 x 1.00, GR5, FT	100-6-24-16-5F	7-47	5
CSHH, 3/8-24 x 1.00, GR5, FT	100-6-24-16-5F	7-48	5
CSHH, 3/8-24 x 1.00, GR5, FT	100-6-24-16-5F	7-56	18
CSHH, 3/8-24 x 1.00, GR5, FT	100-6-24-16-5F	7-57	21
CSHH, 3/8-24 x 1.00, GR8, FT	100-6-24-16-8F	7-58	14
CSHH, 3/8-24 x 1.00, GR8, FT	100-6-24-16-8F	7-59	14
CSHH, 3/8-16 x 2.50, GR5	100-6-16-40-5	7-33	7
CSHH, 5/16 x .75, GR5, FT	100-5-18-12-5F	7-19	26
CSHH, 5/16 x .875, GR5, FT	100-5-18-14-5F	7-19	17
CSHH, 5/16-18 x .75, GR5, FT	100-5-18-12-5F	7-27	15
CSHH, 5/16-18 x .75, GR5, FT	100-5-18-12-5F	7-47	61
CSHH, 5/16-18 x .75, GR5, FT	100-5-18-12-5F	7-48	61
CSHH, 5/16-18 x .875, GR5, FT	100-5-18-14-5F	7-17	4
CSHH, 5/16-18 x .875, GR5, FT	100-5-18-14-5F	7-18	2
CSHH, 5/16-18 x 1.00, GR5	100-5-18-16-5	7-8	7
CSHH, 5/16-18 x 1.00, GR5	100-5-18-16-5	7-10	18
CSHH, 5/16-18 x 1.00, GR5	100-5-18-16-5	7-27	38
CSHH, 5/16-18 x 1.00, GR5	100-5-18-16-5	7-30	13
CSHH, 5/16-18 x 1.00, GR5	100-5-18-16-5	7-47	55
CSHH, 5/16-18 x 1.00, GR5	100-5-18-16-5	7-48	55
CSHH, 5/16-18 x 1.00, GR5, FT	100-5-18-16-5F	7-23	7
CSHH, 5/16-18 x 1.00, GR5, FT	100-5-18-16-5F	7-34	21
CSHH, 5/16-18 x 1.00, GR5, FT	100-5-18-16-5F	7-35	21
CSHH, 5/16-18 x 1.25, GR5	100-5-18-20-5	7-58	17
CSHH, 5/16-18 x 1.25, GR5	100-5-18-20-5	7-59	17
CSHH, 5/16-18 x 1.75, GR5	100-5-18-28-5	7-44	14
CSHH, 5/16-18 x 1.75, GR5	100-5-18-28-5	7-67	14
CSHH, 5/8-11 x 1.00, GR5, FT	100-10-11-16-5F	7-3	11

7

Alphabetical Parts Index

Description	Part No.	Figure No.	Item No.
CSHH, 5/8-11 x 1.25, GR5, FT	100-10-11-20-5F	7-4	27
CSHH, 5/8-11 x 1.25, GR5, FT	100-10-11-20-5F	7-76	5
CSHH, 5/8-11 x 1.25, GR5, FT	100-10-11-20-5F	7-77	18
CSHH, 5/8-11 x 1.375, GR5, FT	100-10-11-22-5F	7-8	28
CSHH, 5/8-11 x 1.75, GR5	100-10-11-44-5	7-8	37
CSHH, 5/8-11 x 2.00, GR5	100-10-11-32-5	7-68	9
CSHH, 5/8-11 x 2.25, GR5	100-10-11-36-5	7-20	7
CSHH, 5/8-11 x 2.25, GR5	100-10-11-36-5	7-52	14
CSHH, 5/8-11 x 2.50, GR5	100-10-11-40-5	7-20	2
CSHH, 5/8-11 x 2.50, GR5	100-10-11-40-5	7-50	29
CSHH, 5/8-11 x 2.75, GR5	100-10-11-44-5	7-71	4
CSHH, 5/8-11 x 3.25, GR5	100-10-11-52-5	7-27	28
CSHH, 5/8-11 x 3.50, GR5	100-10-11-60-5	7-67	5
CSHH, 5/8-11 x 3.75, GR5	100-10-11-60-5	7-44	5
CSHH, 7/16-14 x 1.75, GR5	100-7-14-28-5	7-27	7
CSHH, 7/16-20 x 1.75, GR5	100-7-20-28-5	7-20	17
CSHH, 7/16-20 x 2.00, GR5, FT	100-7-20-32-5F	7-7	22
CSHH, 7/8-9 x 2.00, GR5, FT	100-14-9-32-5F	7-65	4
CSHH, 7/8-9 x 2.00, GR5, FT	100-14-9-32-5F	7-66	4
CSHH, 7/8-9 x 2.50, GR5	100-14-9-40-5	7-34	28
CSHH, 7/8-9 x 2.50, GR5	100-14-9-40-5	7-35	28
CSHH, 9/16-12 x 1.50, GR5, FT	100-9-12-24-5F	7-4	20
CSHH, 9/16-12 x 2.50, GR5	100-9-12-44-5	7-7	5
CSHH, M10x1.50 x 16	989272-50	7-1	35
CSHH, M12x1.75 x 30mm, C8.8, FT	100-M12-1.75-30-8.8F	7-13	18
CSHH, M12x1.75 x 40, C8.8, FT	100-M12-1.75-40-8.8F	7-1	17
CSHH, M12x1.75 x 40mm, C10.9, FT	100-M12-1.75-35-10.9F	7-16	22
CSHH, M12x1.75 x 50, C8.8, FT	100-M12-1.75-50-8.8F	7-1	14
CSHH, M12x1.75 x 50, C8.8, FT	100-M12-1.75-50-8.8F	7-2	16
CSHH, M12x1.75 x 60, C8.8, FT	100-M12-1.75-60-8.8F	7-2	14
CSHH, M16x2 x 30, C8.8, FT	100-M16-2-30-8.8F	7-1	30
CSHH, M16x2 x 35, C8.8, FT	100-M16-2-35-8.8F	7-2	19
CSHH, M16x2 x 40mm, C8.8, FT	100-M16-2-40-8.8F	7-13	20
CSHH, M16x2 x 60, C8.8, FT	100-M16-2-60-8.8F	7-2	21
CSHH, M16x2 x 65, C8.8, FT	100-M16-2-65-8.8F	7-1	28
CSSH, 1/2-13 x 1.25, FT	102-8-13-20-F	7-8	31
CSSH, 1/2-13 x 1.75, GR8	100-8-13-28-8	7-16	13
CSSH, 1/4-20 x 1.00, GR5, FT	100-4-20-16-5F	7-2	10
CSSH, 3/8-16 x 1.50, FT	102-6-16-24-F	7-8	22

Alphabetical Parts Index

Description	Part No.	Figure No.	Item No.
CSSH, 3/8-16 x 2.50	102-6-16-40	7-8	48
CSSH, M10x1.25 x 30mm, C10.9, FT	102-M10-1.5-30-10.9F	7-16	6
CSSH, M10x1.5 x 30, C10.9, FT	102-M10-1.5-30-10.9F	7-1	10
CSSH, M12x1.75 x 40, C8.8, FT	102-M12-1.75-40-8.8F	7-1	23
CSSH, M12x1.75 x 40, C8.8, FT	102-M12-1.75-40-8.8F	7-2	28
CSSQH, 5/8-11 x 3.50, FT	124-10-11-56F	7-5	6
Cupholder Mount Weldment	1017459	7-26	10
Cupholder Weldment	1017632	7-26	9
Cut-Off Assembly - Left	1016517	7-8	17
Cut-Off Assembly - Right	1016518	7-8	18
Cut-Off Cylinder Mounting Shaft	1006988	7-8	14
Cut-Off Hinge Bar	1007064	7-8	19
CV04 Check Valve	983643-08	7-21	6
CV08 Check Valve	983643-09	7-21	3
Cylinder Mount Pin	981661	7-57	10
Cylinder Mounting Pin	981661	7-32	26
Cylinder, Track Tensioner	1016146-02	7-2	6

-D-

Dash Channel Cover	1007264	7-27	37
Dash Light - Blue	31986	7-28	5
Dash Light - Blue	31986	7-29	5
Dash Light - Green	31985	7-28	4
Dash Light - Green	31985	7-29	4
Dash Pin Lock Plate	1007333	7-27	13
Dash Slide Rail w/Holes	1007332	7-27	2
Dash Slide Stop Bracket	1008093	7-27	5
Dash Support Weldment	1016654	7-27	18
Decal - Berm Height Indicator	1015362	7-47	19
Decal - Berm Height Indicator	1015362	7-48	19
Decal - Calibration	1016261	7-28	31
Decal - Calibration	1016261	7-29	29
Decal - Control Box Operation	1016362	7-28	2
Decal - Control Box Operation	1017811	7-29	2
Decal - Dual Joystick Operation	986539	7-26	5
Decal - Electric Heat	1011180	7-45	4
Decal - Fuse Diagram	1017345	7-28	41
Decal - Fuse Diagram	1017345	7-29	39
Decal - Power Crown	1007677-06	7-53	30

Alphabetical Parts Index

Description	Part No.	Figure No.	Item No.
Decal - Relay Diagram	1017351	7-28	35
Decal - Relay Diagram	1017351	7-29	33
Decal - Screed Control - Left	1017795	7-39	25
Decal - Screed Control - Right	1017794	7-40	25
Decal - Screed Control Operation - Left	1016247	7-37	16
Decal - Screed Control Operation - Left	1016247	7-63	14
Decal - Screed Control Operation - Right	1016248	7-38	16
Decal - Screed Control Operation - Right	1016248	7-64	14
Decal - Spray Down Pump Operation	1016094	7-19	20
Decal - Steering Wheel Operations	1002080	7-70	2
Decal - Test Port Info	1017186	7-11	3
Decal - Thicker/Thinner	856472	7-20	25
Decal - Umbrella	988207	7-78	2
Depth Screw Control Bracket - Left	890132LSRV	7-65	5
Depth Screw Control Bracket - Left	890132RSRV	7-66	5
Depth Screw Endgate Assembly	890092SRV	7-52	4
Deutsch Pin	982456	7-28	30
Deutsch Pin	982456	7-29	28
Directional Solenoid Valve	1011728-01	7-21	4
Directional Solenoid Valve	983643-01	7-68	14
Double Row Chain Assembly, 50-2	900404	7-72	4
Drive Motors Hose Kit	1016854	7-1	REF
Drive Motors Hose Kit	1016854	7-2	REF
Driver Side Toeboard	1016550	7-17	17
Dual Joystick Box Weldment - Left	1017458	7-26	6
Dual Joystick Box Weldment - Right	1017466	7-26	7
Dual Joystick Control Box	1016272SRV	7-26	4
Dual Pilot Operated Check Valve	983643-05	7-21	2
-E-			
ECU	1009253-24	7-14	9
ECU Mounting Bracket	1009253-01	7-14	10
Edge Trim - Lower	1016438	7-17	10
Edge Trim - Lower	1016438	7-18	9
Edge Trim - Upper	1016435	7-17	9
Edge Trim - Upper	1016435	7-18	8
Elbow Adapter, 45°, -12 ORFS/-12 O-Ring	FS6802-12-12-NWO-FG	7-22	6
Elbow Adapter, 45°, -16 ORFS/-16 O-Ring	FS6802-16-16-NWO-FG	7-10	4
Elbow Adapter, 45°, -4 ORFS/-4 O-Ring	FS6802-04-04-NWO-FG	7-1	46

Alphabetical Parts Index

Description	Part No.	Figure No.	Item No.
Elbow Adapter, 45°, -4 ORFS/-4 O-Ring	FS6802-04-04-NWO-FG	7-2	34
Elbow Adapter, 45°, -6 ORFS/-6 NPTF	FS2503-06-06-FG	7-8	58
Elbow Adapter, 45°, -6 ORFS/-6 NPTF	FS2503-06-06-FG	7-25	18
Elbow Adapter, 45°, -6 ORFS/-6 O-Ring	FS6802-06-06-NWO-FG	7-25	20
Elbow Adapter, 45°, -8 ORFS/-8 O-Ring	FS6802-08-08-NWO-FG	7-10	33
Elbow Adapter, 45°, -8 ORFS/-8 O-Ring	FS6802-08-08-NWO-FG	7-22	12
Elbow Adapter, 90°, -10 ORFS/-10 O-Ring	FS6801-10-10-NOW-FG	7-16	4
Elbow Adapter, 90°, -10 ORFS/-10 O-Ring	FS6801-10-10-NOW-FG	7-21	15
Elbow Adapter, 90°, -10 ORFS/-12 O-Ring	FS6801-10-12-NWO-FG	7-1	45
Elbow Adapter, 90°, -10 ORFS/-12 O-Ring	FS6801-10-12-NWO-FG	7-2	33
Elbow Adapter, 90°, -10 ORFS/-12 O-Ring	FS6801-10-12-NWO-FG	7-16	20
Elbow Adapter, 90°, -10 ORFS/-12 O-Ring	FS6801-10-12-NWO-FG	7-25	6
Elbow Adapter, 90°, -12 ORFS/ -10 O-Ring	FS6801-12-10-NWO-FG	7-21	14
Elbow Adapter, 90°, -12 ORFS/-12 ORFS	FS6500-12-12-FG	7-12	4
Elbow Adapter, 90°, -12 ORFS/-12 O-Ring	FS6801-12-12-NWO-FG	7-10	12
Elbow Adapter, 90°, -12 ORFS/-12 O-Ring	FS6801-12-12-NWO-FG	7-16	12
Elbow Adapter, 90°, -16 ORFS/ -16 O-Ring	FS6801-16-16-NWO-FG	7-23	6
Elbow Adapter, 90°, -16 ORFS/-16 O-Ring	FS6801-16-16-NWO-FG	7-16	21
Elbow Adapter, 90°, -16 ORFS/-20 O-Ring	FS6801-16-20-NWO-FG	7-10	30
Elbow Adapter, 90°, -24 ORFS/-24 O-Ring	FS6801-24-24-NWO-FG	7-10	14
Elbow Adapter, 90°, -4 ORFS/-4 O-Ring	FS6801-04-04-NWO-FG	7-22	4
Elbow Adapter, 90°, -4 ORFS/-4 O-Ring, .078 Orifice	FS6801-04-04-NWO-FG X 078	7-22	8
Elbow Adapter, 90°, -4 ORFS/-6 O-Ring	FS6801-04-06-NWO-FG	7-1	44
Elbow Adapter, 90°, -4 ORFS/-6 O-Ring	FS6801-04-06-NWO-FG	7-2	32
Elbow Adapter, 90°, -4 ORFS/-6 O-Ring	FS6801-04-06-NWO-FG	7-10	11
Elbow Adapter, 90°, -4 ORFS/-6 O-Ring	FS6801-4-6-NWO-FG	7-16	10
Elbow Adapter, 90°, -6 JIC / -6 NPT	2501-6-6	7-19	21
Elbow Adapter, 90°, -6 JIC / -6 NPTF	2502-6-6	7-19	6
Elbow Adapter, 90°, -6 ORFS/ -6 NPTF	FS2501-06-06-FG	7-8	13
Elbow Adapter, 90°, -6 ORFS/-4 O-Ring	FS6801-06-04-NWO-FG	7-10	16
Elbow Adapter, 90°, -6 ORFS/-6 NPTF	FS2501-06-06-FG	7-25	17
Elbow Adapter, 90°, -6 ORFS/-6 NPTF	FS2501-06-06-FG	7-33	18
Elbow Adapter, 90°, -6 ORFS/-6 NPTF	FS2503-06-06-FG	7-33	19
Elbow Adapter, 90°, -6 ORFS/-6 NPTF	FS2501-06-06-FG	7-77	29
Elbow Adapter, 90°, -6 ORFS/-6 O-Ring	FS6801-06-06-NWO-FG	7-7	39
Elbow Adapter, 90°, -6 ORFS/-6 O-Ring	FS6801-6-6-NWO-FG	7-21	10
Elbow Adapter, 90°, -6 ORFS/-6 O-Ring	FS6801-06-06-NWO-FG	7-25	3
Elbow Adapter, 90°, -6 ORFS/-8 O-Ring	FS6801-06-08-NWO-FG	7-10	34
Elbow Adapter, 90°, -6 O-Ring/-4 NPTF	6806-6-4 NWO	7-7	36

Alphabetical Parts Index

Description	Part No.	Figure No.	Item No.
Elbow Adapter, 90°, -6 O-Ring/-4 NPTF	6806-6-4 NWO	7-25	12
Elbow Adapter, 90°, -8 ORFS/-10 O-Ring	FS6801-08-10-NWO-FG	7-22	5
Elbow Adapter, 90°, Swivel, -12 ORFS/-12 ORFS	FS6500-12-12-FG	7-22	14
Electric Screw Assembly - Left	853853L	7-20	19
Electric Screw Assembly - Right	853853R	7-20	REF
Electric Screw Rod End Clevis	851211	7-20	21
Electric Selector Valve, 6-Way	989656	7-53	28
Electric Timer, 06 - 60 MIN	985142	7-45	13
Electric Vibrator Harness	1019724	7-43	REF
Electric Vibrator Mounting Plate	1018801	7-43	2
Electronic Steering Cord, 4 Ft.	851548-04	7-26	REF
Element Backup Bar	1011155	7-51	8
Element Backup Bar	1011155	7-52	11
Element Backup Plate, 12"	1007991	7-47	38
Element Backup Plate, 12"	1007991	7-48	38
Element Clamp Bar	1006033	7-47	33
Element Clamp Bar	1006033	7-48	33
Element Wire Routing Tube	1011491	7-51	17
Enclosure Mounting Plate	1007263	7-27	6
Emergency Stop Switch, 1-NC	1010672	7-39	24
Emergency Stop Switch, 1-NC	1010672	7-40	24
Enclosure, 10 x 8 x 4	100804	7-45	1
Enclosure, Rain-Tight, 8H x 8W x 6D	1017395	7-69	1
End Gate Skid Bar	982963SRV	7-65	6
End Gate Skid Bar	982963SRV	7-66	6
Endgate Adjustment Tube	1011235	7-42	12
Endgate Adjustment Tube	1011235	7-51	16
Endgate Adjustment Tube	1011235	7-52	22
Endgate Assembly - Left	983308SRV	7-65	1
Endgate Assembly - Right	983309SRV	7-66	1
Endgate Attachment Threaded Rod	1016800	7-47	8
Endgate Attachment Threaded Rod	1016800	7-48	8
Endgate Bracket Plate w/Holes	1006536	7-34	26
Endgate Bracket Plate w/Holes	1006536	7-35	26
Endgate Bracket Plate w/Holes	1006536	7-47	4
Endgate Bracket Plate w/Holes	1006536	7-48	4
Endgate Depth Screw Assembly	890092SRV	7-42	3
Endgate Depth Screw Assembly	890092	7-51	3
Endgate Plate	1006442	7-42	5

Alphabetical Parts Index

Description	Part No.	Figure No.	Item No.
Endgate Plate	1006442	7-51	5
Endgate Tilt Screw Assembly	890081SRV	7-65	11
Endgate Tilt Screw Assembly	890081SRV	7-66	11
Engine Cover & Deflectors Weldment	1016419	7-17	3
Engine Cover Weldment - Left	1016542	7-17	7
Engine Cover Weldment - Right	1016544	7-18	6
Engine Isolator	986537-14	7-13	16
EP10-S35T-0-N-230	1017450-03	7-22	19
E-Stop Switch	1010672	7-28	15
E-Stop Switch	1010672	7-29	11
Extension Access Cover Plate	1006398	7-34	20
Extension Access Cover Plate	1006398	7-35	20
Extension Access Cover Plate	1006398	7-47	54
Extension Access Cover Plate	1006398	7-48	54
Extension Adjust Screw Assembly	851185SRV	7-58	4
Extension Adjust Screw Assembly	851185SRV	7-59	4
Extension Adjust Screw Assembly	851185SRV	7-60	6
Extension Adjust Screw Assembly	851185SRV	7-61	6
Extension Adjuster Cover	1006439	7-34	14
Extension Adjuster Cover	1006439	7-35	14
Extension Adjuster Cover	1006439	7-47	46
Extension Adjuster Cover	1006439	7-48	46
Extension Assembly - Left	985561SRV	7-58	1
Extension Assembly - Right	985562SRV	7-59	1
Extension Assembly w/o Slope - Left	984305-1SRV	7-60	REF
Extension Assembly w/o Slope - Right	984306-1SRV	7-61	REF
Extension Assembly w/Slope - Left	984305SRV	7-60	1
Extension Assembly w/Slope - Right	984306SRV	7-61	1
Extension Electric Vibrator Harness	1017742	7-53	REF
Extension Element Hose & Wiring Kit	1015990SRV	7-34	REF
Extension Element Hose & Wiring Kit	1015990SRV	7-35	REF
Extension Element Hose & Wiring Kit	1015990SRV	7-42	REF
Extension Element Hose & Wiring Kit	1015990SRV	7-51	REF
Extension Element Hose & Wiring Kit	1015990SRV	7-52	REF
Extension Heatbox Assembly - Left	1006380SRV	7-34	4
Extension Heatbox Assembly - Right	1006380SRV	7-35	4
Extension Hold Down Bar	1015319	7-32	9b
Extension Rod - Left	986650	7-68	REF
Extension Rod - Right	986636	7-68	REF

7

Alphabetical Parts Index

Description	Part No.	Figure No.	Item No.
Extension Slide Weldment	1015428	7-47	3
Extension Slide Weldment	1015427	7-47	17
Extension Slide Weldment	1015416	7-48	3
Extension Slide Weldment	1015415	7-48	17
Extension Spring, .177 x 1.50 x 7.00	930029	7-27	24
Extension Strikeoff Plate	1006400	7-34	23
Extension Strikeoff Plate	1006400	7-35	23
Extension Vibrator Weldment	1008664	7-34	25
Extension Vibrator Weldment	1008664	7-35	25
Extension, 6" (Left)	851634LSRV	7-73	5
Extension, 6" (Right)	851634RSRV	7-73	6
-F-			
Fan Belt	1009253-20	7-13	11
FD10 Flow Divider	983643-10	7-21	7
Fender Washer, 3/8	981511	7-4	34
Fiber Bushing, 2.00 ID x 2.25 OD	1006417	7-36	3
Filler Neck	140030FN	7-9	8
Filler Neck	140030FN	7-10	22
Fire Extinguisher, 10 Lbs., 4A:80B:c	1014536	7-78	REF
Fire Extinguisher, 5 Lbs., 3A:40B:C	35828	7-78	REF
Fitting, Push Lok, 90°, Short, -10 FJX/-10 Hose	33982-10-10	7-53	32
Flat Washer	856046	7-77	20
Flat Washer, .500 x 2.00 x .188	855735	7-77	16
Flat, Washer, SAE, 3/8	300-6	7-53	4
Flight Screw Assembly	851370SRV	7-63	15
Flight Screw Assembly	851370SRV	7-64	15
Flight Screw Lock Mounting Tab	1014068	7-50	26
Flight Screw Sub-Assembly	859365	7-63	17
Flight Screw Sub-Assembly	859365	7-64	17
Flight/Depth Screw Hand Grip	870276	7-63	16
Flight/Depth Screw Hand Grip	870276	7-64	16
Flight/Depth Screw Hand Grip	870276	7-65	12
Flight/Depth Screw Hand Grip	870276	7-66	12
Floor Board Grating - Left	1015504	7-17	16
Floor Board Grating - Right	1015503	7-18	15
Front Engine Mount - Left	986537-17	7-13	13
Front Engine Mount - Right	986537-16	7-13	14
Front Idler	983530	7-2	4

Alphabetical Parts Index

Description	Part No.	Figure No.	Item No.
Front Lip Clamp	985581	7-4	16
Front Lip Guard Assembly	985669SRV	7-4	1
Front Lip Rubber - Center	985058	7-7	20
Front Lip Rubber - Outer	985057	7-7	18
Front Lip Weldment - Left	1013153SRV	7-4	3
Front Lip Weldment - Right	1013152SRV	7-4	2
Front Track Idler Yoke, Short	811329ASRV	7-1	5
Front Track Idler Yoke, Short	811329ASRV	7-2	5
Fuel Cap Filler Neck	140030FN	7-44	3
Fuel Cap Filler Neck	140030FN	7-67	3
Fuel Filler Strainer & Gasket Kit	140030GK	7-44	4
Fuel Filler Strainer & Gasket Kit	140030GK	7-67	4
Fuel Filter	1009253-18	7-14	14
Fuel Filter Mount	1016249-08	7-14	15
Fuel Pick Up Tube	1014538-20.5	7-9	3
Fuel Pump with Filter	1010471	7-14	11
Fuel Pump/Filters Mount	1016249-07	7-14	16
Fuel Sender	1009253-36	7-14	13
Fuel Sending Unit	1016262	7-9	5
Fuel Tank Assembly	1016269	7-9	REF
Fuel Tank Cap - Lockable	140030FL	7-44	2
Fuel Tank Cap - Lockable	140030FL	7-67	2
Fuel Tank Weldment	1015904	7-9	1
Fuel/Water Seperator Filter	1009253-19	7-14	12
Fuse Block	1011049-39	7-14	5
Fuse Block Bracket Plate	1016713	7-14	6
Fuse Block, 18 Gang, ATC	685060	7-28	40
Fuse Block, 18 Gang, ATC	685060	7-29	38
Fuse Box Foam Rubber	1009253-45	7-15	5
Fuse Holder	1009253-27	7-14	4
Fuse, 10A, ATC	36340	7-28	REF
Fuse, 10A, ATC	36340	7-29	REF
Fuse, 15A, ATC	36341	7-28	REF
Fuse, 15A, ATC	36341	7-29	REF
Fuse, 20A, ATC	36342	7-28	REF
Fuse, 20A, ATC	36342	7-29	REF
Fuse, 25A, ATC	37303	7-28	REF
Fuse, 25A, ATC	37303	7-29	REF
Fuse, 5A, ATC	36746	7-28	REF

Alphabetical Parts Index

Description	Part No.	Figure No.	Item No.
Fuse, 5A, ATC	36746	7-29	REF
-G-			
Gasket/Strainer Kit	140030GK	7-9	7
Gasket/Strainer Kit	140030GK	7-10	21
GC-35 Controller Assembly	1010499-08	7-76	14
GC-35 Paver Bracket Assembly	1010499-05	7-76	20
GC-35 Quick Reference Guide	1010499-01	7-76	19
GC-35/Sonic Tracker Cord Assembly (15 ft.)	1010499-04	7-76	17
Generator Assembly, 10kW	1017009	7-24	1
Generator Mount	1017183	7-24	6
Generator Tray	1017061	7-13	25
Generator Valve Adapter Harness	1017192	7-28	REF
Generator Valve Adapter Harness	1017192	7-29	REF
Grease Fitting, 1/4-28, Long	1008949	7-8	50
Grease Fitting, 1/8 NPT Straight	29A-02	7-8	45
Grip Strut Walkboard Assembly w/Extension - Left	1017489	7-43	14
Grip Strut Walkboard Assembly w/Extension - Right	1017490	7-43	15
Grip Strut Weldment - Left	1016463	7-43	8
Grip Strut Weldment - Right	1016462	7-43	9
Gripper Clamp	920238-1	7-49	12
Group - 815HD Electric Vibrators	1019720	7-43	GRP
Group - 815HD Gripstrut Walkboard	1016995	7-43	GRP
Group - Adjustable Pushbar w/Counterweight	1017211	7-3	GRP
Group - Cast Steel Drive	1017205	7-1	GRP
Group - Citrus Tank for Berm Option	1017163	7-44	20
Group - Conveyor Assembly	1017200	7-4	GRP
Group - Conveyor Assembly	1017200	7-5	GRP
Group - Conveyor Assembly	1017200	7-6	GRP
Group - HD Heated Endgates and Safety Edge	1017025	7-52	GRP
Group - Heated HD Endgates	1017024	7-51	GRP
Group - Mechanical Crown	1007212	7-33	GRP
Group - PolyPad Drive	1017203	7-1	GRP
Group - Power Crown w/Slope Option	1017001	7-53	GRP
Group - Rubber Track Drive	1017204	7-2	GRP
Group - Screed Extension Vibrators	1008965SRV	7-53	GRP
Group - Standard Depth Screws	1007206	7-41	GRP
Group - Standard HD Endgates	1017023	7-42	GRP
Group - Steering Wheel Option	1004842SRV	7-70	OPT

Alphabetical Parts Index

Description	Part No.	Figure No.	Item No.
Guard Clamp	802112SRV	7-4	19
Guide Bar	920061	7-7	27
Guide Bar Assembly	853887SRV	7-7	24
Guide Bar Inner Tube	920051	7-7	26
Guide Bar Outer Tube	920041	7-7	25
Guide Wheel Assembly	930055	7-77	25
Guide Wheel Axle Assembly	930045SRV	7-77	24
-H-			
Hair Pin Clip, Clevis Pin	870307	7-74	8
Hair Pin Clip, Clevis Pin	870307	7-75	12
Hand Grip	870276	7-42	13
Hand Grip	870276	7-51	18
Hand Grip	870276	7-52	23
Handle Nut, 5/8-11	300060	7-76	3
Harness Bracket	1009253-29	7-14	2
HD Chromed Screed Extension Shaft	1006415	7-36	5
HD Endgate Assembly - Left	1006443SRV	7-42	1a
HD Endgate Assembly - Left	1006443SRV	7-51	1a
HD Endgate Assembly - Right	1006560SRV	7-42	1b
HD Endgate Assembly - Right	1006560SRV	7-51	1b
HD Screed Insulation	1015018	7-33	4
HD Slide w/o Shaft Assembly	1006445	7-36	2
HD Slide w/Shaft Assembly	1006416	7-36	1
Heat Box Assembly - 4 Adjust	988319SRV	7-60	2
Heat Box Assembly - 4 Adjust	988319SRV	7-61	2
Heat Box Assembly - Single Adjust	987872SRV	7-58	2
Heat Box Assembly - Single Adjust	987872SRV	7-59	2
Heat Box Cover Assembly - 4 Adjust	988292SRV	7-60	14
Heat Box Cover Assembly - 4 Adjust	988292SRV	7-61	14
Heat Box Cover Assembly - Single Adjust	988291	7-58	12
Heat Box Cover Assembly - Single Adjust	988291	7-59	12
Heat Box Hinge Pin	1015350	7-47	2
Heat Box Hinge Pin	1015350	7-48	2
Heated Edge HD Endgate Assembly - Left	1011187SRV	7-52	REF
Heated Edge HD Endgate Assembly - Right	1011156SRV	7-52	REF
Heated Endgate Depth Screw Bracket - Left	1011204	7-42	2a
Heated Endgate Depth Screw Bracket - Left	1011204	7-51	2a
Heated Endgate Depth Screw Bracket - Right	1011203	7-42	2b

Alphabetical Parts Index

Description	Part No.	Figure No.	Item No.
Heated Endgate Depth Screw Bracket - Right	1011203	7-51	2b
Heated HD Endgate Assembly - Left	1011143SRV	7-51	REF
Heated HD Endgate Assembly - Right	1011144SRV	7-51	REF
Heated Safety Edge HD Hinge Pin Weldment	1011195	7-52	5
Heated Safety Edge HD Skid Weldment - Left	1011190	7-52	3a
Heated Safety Edge HD Skid Weldment - Right	1011165	7-52	3b
Heated Safety Edge Main Plate Weldment - Left	1011189	7-52	1a
Heated Safety Edge Main Plate Weldment - Right	1011161	7-52	1b
Heater Element, 1000W/220V, 41"	987890SRV	7-58	9
Heater Element, 1000W/220V, 41"	987890SRV	7-59	9
Heater Element, 1000W/220V, 41"	987890SRV	7-60	11
Heater Element, 1000W/220V, 41"	987890SRV	7-61	11
Heater Element, 1750W/220V, 46.5"	987886SRV	7-57	12
Heater Element, 1750W/220V, 46"	987886SRV	7-56	9
Heating Element, 1000W/220V, 41"	987890SRV	7-34	12
Heating Element, 1000W/220V, 41"	987890SRV	7-35	12
Heating Element, 1000W/240V, 30"	1015936	7-47	34
Heating Element, 1000W/240V, 30"	1015936	7-48	34
Heating Element, 500W/220V, 30"	1011158	7-51	9
Heating Element, 500W/220V, 30"	1011158	7-52	12
Heating Element, 500W/240V, 11"	1015918	7-47	39
Heating Element, 500W/240V, 11"	1015918	7-48	39
High Pressure O-Ring Kit	1019632	7-21	16
Hinge	980316	7-17	20
Hinge Assembly	1002735SRV	7-60	3
Hinge Assembly	1002736SRV	7-61	3
Hinge Rod Retainer Tab	1015357	7-47	62
Hinge Rod Retainer Tab	1015357	7-48	62
Hopper Lift Hydraulic Cylinder Assembly	1019173	7-25	REF
Hopper Safety Rod Weldment	1016760	7-4	7
Hopper Wing Cylinder Bracket	855426	7-7	15
Hopper Wing Hinge Pin	854084	7-7	35
Hopper Wing Lock Pin	1013877	7-7	34
Hopper Wing Rubber Plate	980727	7-7	4
Hopper Wing Sequence Manifold	910122	7-25	1
Hopper Wing Sequence Manifold Assembly	1019176	7-25	REF
Hopper Wing Weldment - Left	980702SRV	7-7	1
Hopper Wing Weldment - Right	980703SRV	7-7	2
Horn, Low Pitch	20190773	7-30	9

Alphabetical Parts Index

Description	Part No.	Figure No.	Item No.
Hose Clamp, #04 (.22 - .62)	33277	7-19	9
Hose Clamp, 2.86"	1016249-28	7-13	8
Hose Clamp, 3.50"	1016249-29	7-13	5
Hose Clamp, 4.00"	1016249-30	7-13	2
Hose Reel Mount - Left	1016541	7-19	25
Hydraulic Charge Filter Element	290030	7-25	5
Hydraulic Charge/Return Filter Head	1017402	7-25	4
Hydraulic Cooler Harness	1016702	7-23	REF
Hydraulic Cooler Harness	1016702	7-28	REF
Hydraulic Cooler Harness	1016702	7-29	REF
Hydraulic Cooler Harness, SPAL Fan	1019514	7-23	REF
Hydraulic Cylinder Seal Kit	851191-01	7-56	REF
Hydraulic Cylinder Seal Kit	851191-01	7-57	REF
Hydraulic Cylinder, 1.50 x 30.00 x 1.00 Rod	930070	7-77	7
Hydraulic Cylinder, 2.00 x 12.00/30.00 x 1.25 - Left	851191	7-56	19
Hydraulic Cylinder, 2.00 x 12.00/30.00 x 1.25 - Left	851191	7-57	23
Hydraulic Cylinder, 2.00 x 12.00/30.00 x 1.25 - Right	851192	7-56	20
Hydraulic Cylinder, 2.00 x 12.00/30.00 x 1.25 - Right	851192	7-57	24
Hydraulic Cylinder, 2.00 x 2.00 x 42.00 x 1.25 Rod	981710L	7-33	13
Hydraulic Cylinder, 2.00 x 2.00 x 42.00 x 1.25 Rod	981710R	7-33	14
Hydraulic Cylinder, 2.00 x 6.00	987725	7-20	REF
Hydraulic Cylinder, 2.00 x 8.22 x 1.00	610110	7-7	12
Hydraulic Cylinder, 2.00 x 8.22 x 1.00 Rod	610110	7-25	9
Hydraulic Cylinder, 2.50 x 4.00 x 1.25 Rod	910170	7-8	10
Hydraulic Cylinder, 2.50 x 4.00 x 1.25 Rod	910170	7-25	16
Hydraulic Cylinder, 2.75 x 2.00 x 1.125	983421	7-57	25
Hydraulic Cylinder, 2.75 x 2.00 x 1.125 Rod	983421	7-33	15b
Hydraulic Cylinder, Track Tensioner	811331	7-1	6
Hydraulic Drive Motor, 2-Speed	811362	7-1	22
Hydraulic Drive Motor, 2-Speed	811362	7-2	27
Hydraulic Filter Assembly	984594	7-22	16
Hydraulic Filter Assembly w/ORFS Adapters, 3000 PSI, 25 GPM	1019175	7-22	REF
Hydraulic Filter Element	984594-01	7-22	REF
Hydraulic Level Sensor	1014643	7-10	13
Hydraulic Manifold, 9-Station, 7 Valve	1011728	7-21	REF
Hydraulic Manifold, Motor Functions w/10 kW Gen Controller	1017982	7-22	REF
Hydraulic Motor	986640	7-53	11
Hydraulic Motor	986640	7-68	1
Hydraulic Motor, 22.0 CIR	260130	7-6	23

7

Alphabetical Parts Index

Description	Part No.	Figure No.	Item No.
Hydraulic Motor, 22.0 CIR	260130	7-8	23
Hydraulic Needle Valve	35552	7-68	13
Hydraulic Oil Level/Temp Sight Gauge	500070	7-10	20
Hydraulic Oil Temperature Sender, 100-250°F	1010402	7-10	10
Hydraulic Pressure Test Kit	1013595	7-11	4
Hydraulic Pump, Tandem, 22.5 CC/19 CC, 9T	1017733	7-16	1
Hydraulic Suction Strainer, 100 Mesh, O-Ring	1014037	7-10	3
Hydraulic Suction Strainer, -24 SAE O-Ring	1011817	7-10	2
Hydraulic Tank Weldment	1015883	7-10	1
Hydraulic Test to #4 JIC Bulkhead	1013583	7-11	2
Hydraulic Tow Point Hose Kit	1018637	7-20	REF
-i, J, K-			
Ignition Key	982008-04	7-28	REF
Ignition Key	982008-04	7-29	REF
Ignition Switch	39146-14	7-28	7
Ignition Switch	39146-14	7-29	7
Indicator Light - White	1010500	7-28	6
Indicator Light - White	1010500	7-29	6
Inline Filter	986537-31	7-19	10
Inner Conveyor Drive Sprocket	850030SRV	7-6	6
Inner Extension Assembly - Left	1007097SRV	7-34	34
Inner Extension Assembly - Right	1007099SRV	7-35	34
Inner Plate Assembly - Left	1006993	7-32	1
Inner Plate Assembly - Right	1006994	7-32	2
Inner Tube Pedestal Support Weldment	1017488	7-27	26
Insert Bearing, 1.50	850130	7-3	4
Insulation, .25 x 1.00 x 12.00 w/Adhesive	986522	7-34	11
Insulation, .25 x 1.00 x 12.00 w/Adhesive	986522	7-35	11
Intake Reducer, 3.00" - 3.50"	1002676-23	7-13	4
Intermediate Engine Harness	1011799-24	7-14	7
Jumper C3 Dash To Pedestal Harness	1016264	7-28	REF
Jumper C3 Dash To Pedestal Harness	1016264	7-29	REF
Jumper C4 Dash To Pedestal Harness	1016263	7-28	REF
Jumper C4 Dash To Pedestal Harness	1016263	7-29	REF
Jumper Heater Element Harness	1008877	7-28	REF
Jumper Heater Element Harness	1008877	7-29	REF
Junction Box	920238-6	7-49	1
Junction Box Blank Cover	920238-7	7-49	2

Alphabetical Parts Index

Description	Part No.	Figure No.	Item No.
Junction Box to Control Box Cable	983416-01	7-76	REF
Key, .25 x .25 x 1.25	1011309	7-41	16
Knob	35049	7-39	19
Knob	35049	7-40	19
Knob, 1/4" Shaft	35049	7-28	11
Kubota Engine, T4F, 74HP	1016478	7-12	REF
Kubota Engine, T4F, 74HP	1016478	7-13	REF
Kubota Engine, T4F, 74HP	1016478	7-14	REF
Kubota Engine, T4F, 74HP	1016478	7-15	REF
-L, M-			
LED Circular Light w/Deutsch Connector	1013307	7-37	4
LED Circular Light w/Deutsch Connector	1013307	7-38	4
LED Circular Light w/Deutsch Connector	1013307	7-39	15
LED Circular Light w/Deutsch Connector	1013307	7-40	15
LED Circular Light w/Deutsch Connector	1013307	7-63	2
LED Circular Light w/Deutsch Connector	1013307	7-64	2
Legend Screed Base - Standard	989377SRV	7-56	1
Legend Screed Base w/Slope	985547SRV	7-57	1
Legend Screed Citrus Tank Assembly	1008862SRV	7-67	1
Lever Latch	980460	7-17	12
Lever Latch	980460	7-18	11
Linear Actuator Rod Weldment	851212	7-20	22
Linear Actuator, 6.00, 12V	851518	7-20	20
Load Control Box to Bulkhead Harness	1016723	7-28	REF
Load Control Box to Bulkhead Harness	1016723	7-29	REF
Load Control Box to Bulkhead Harness	1016723	7-45	REF
Lock Nut, PTORQ, 3/4-16	95998936	7-41	6
Lock, Washer, 3/8	302-6	7-53	3
Lockable Cap, Fuel	140030FL	7-9	10
Lockable Cap, Hydraulic	140030HL	7-10	24
Locking Collar, 2.00	620400	7-77	23
Locknut	95200879	7-41	14
Locknut	95200879	7-50	41
Lockwasher	95200978	7-41	13
Lockwasher	95200978	7-50	40
Lockwasher, 24 Shell	981916-02	7-28	21
Lockwasher, 24 Shell	981916-02	7-29	19
Lockwasher, 24 Shell Connector	981916-02	7-27	32

Alphabetical Parts Index

Description	Part No.	Figure No.	Item No.
Low Socket Cap Screw, M16x2 x 35	1008895	7-1	27
Low Socket Cap Screw, M16x2 x 35	1008895	7-2	22
Low Socket Cap Screw, M16x2 x 45	1008903	7-1	25
Low Socket Cap Screw, M16x2 x 45	1008903	7-2	24
Lower Hydraulic Tank Assembly	1019241	7-10	REF
Lower Hydraulic Tank Weldment	1016275	7-10	25
Lower Intake Pipe	1013710-02	7-13	6
Lower Manifold Assembly w/ ORFS Adapters	1019159	7-22	GRP
Lower Manifold Harness	1016536	7-22	REF
Lower Manifold Harness	1016536	7-28	REF
Lower Manifold Harness	1016536	7-29	REF
Lower Planetary Drive Shaft	1014926	7-50	42
Lower Radiator Hose	1006963-16	7-12	12
Lower Radiator Mount	1009384-12	7-12	8
Lower Screed Cover	1007000	7-32	30
L-Shape Extension Slide Rail - Top	1017612	7-32	12
L-Shape Extension Slide Rail - Bottom	1017614	7-32	11a
L-Shape Extension Slide Rail - Bottom	1018243	7-32	11b
Magnetic Drain Plug, -16 SAE Orb	1011971	7-9	2
Magnetic Drain Plug, -16 SAE Orb	1011971	7-10	6
Main Asphalt Blocker Plate	1015351	7-47	58
Main Asphalt Blocker Plate	1015351	7-48	58
Main Harness	1016579	7-28	REF
Main Harness - 9 Function Screed Control	1017840	7-29	REF
Main Heat Box Assembly - Left	1017683	7-47	27
Main Heat Box Assembly - Right	1017682	7-48	27
Main Heat Box Lid Weldment - Left	1015431	7-47	28
Main Heat Box Lid Weldment - Right	1015419	7-48	28
Male Pipe Dwivel Adapter, -6 NPTF / -6 JIC	6505-6-6	7-19	22
Manifold Bracket Plate	984528	7-10	17
Manual Case	985234-01	7-44	13
Manual Case	985234-01	7-67	13
Manual Turnbuckle Assembly	1016151	7-33	15a
Master Track Link Pin	811306	7-1	REF
Motor Mount	981696	7-8	25
Mounting Bracket, 10 Lbs. Fire Extinguisher	12034-5HD	7-78	REF
Mounting Bracket, 5 Lbs. Fire Extinguisher	12313-5DC	7-78	REF
Mounting Bracket, Watlow	1017737	7-69	3
Mounting Plate, Watlow	1017739	7-69	2

Alphabetical Parts Index

Description	Part No.	Figure No.	Item No.
-N-			
Negative Battery Cable	986803	7-14	21
Nord Wedge Lock Washer, .670	986811	7-68	8
Nut, 24 Shell	981916-01	7-28	20
Nut, 24 Shell	981916-01	7-29	18
Nut, 24 Shell Connector	981916-01	7-27	33
Nut, Connector, HDP20 Series	1011854	7-27	34
Nut, Hex, 1/2-13, GR5	200-8-13-5	7-34	33
Nut, Hex, 1/2-13, GR5	200-8-13-5	7-35	33
Nut, Hex, 1/2-13, GR5	200-8-13-5	7-43	13
Nut, Hex, 1/4-20, GR5	200-4-20-5	7-45	21
Nut, Hex, 1/4-20, GR5	200-4-20-5	7-69	11
Nut, Hex, 1-8, GR5	200-16-8-5	7-72	6
Nut, Hex, 3/8-16, GR5	200-6-16-5	7-5	9
Nut, Hex, 3/8-16, GR5	200-6-16-5	7-7	11
Nut, Hex, 3/8-16, GR5	200-6-16-5	7-24	14
Nut, Hex, 3/8-16, GR5	200-6-16-5	7-32	28
Nut, Hex, 3/8-16, GR5	200-6-16-5	7-34	24
Nut, Hex, 3/8-16, GR5	200-6-16-5	7-35	24
Nut, Hex, 3/8-16, GR5	200-6-16-5	7-37	8
Nut, Hex, 3/8-16, GR5	200-6-16-5	7-38	8
Nut, Hex, 3/8-16, GR5	200-6-16-5	7-47	63
Nut, Hex, 3/8-16, GR5	200-6-16-5	7-48	63
Nut, Hex, 3/8-16, GR5	200-6-16-5	7-50	24
Nut, Hex, 3/8-16, GR5	200-6-16-5	7-51	7
Nut, Hex, 3/8-16, GR5	200-6-16-5	7-52	10
Nut, Hex, 3/8-16, GR5	200-6-16-5	7-63	8
Nut, Hex, 3/8-16, GR5	200-6-16-5	7-64	8
Nut, Hex, 5/16-18, GR5	200-5-18-5	7-30	3
Nut, Hex, 5/16-18, GR5	200-5-18-5	7-34	22
Nut, Hex, 5/16-18, GR5	200-5-18-5	7-35	22
Nut, Hex, 5/16-18, GR5	200-5-18-5	7-37	9
Nut, Hex, 5/16-18, GR5	200-5-18-5	7-38	9
Nut, Hex, 5/16-18, GR5	200-5-18-5	7-39	12
Nut, Hex, 5/16-18, GR5	200-5-18-5	7-40	12
Nut, Hex, 5/16-18, GR5	200-5-18-5	7-50	13
Nut, Hex, 5/16-18, GR5	200-5-18-5	7-58	18
Nut, Hex, 5/16-18, GR5	200-5-18-5	7-59	18
Nut, Hex, 5/16-18, GR5	200-5-18-5	7-63	3

Alphabetical Parts Index

Description	Part No.	Figure No.	Item No.
Nut, Hex, 5/16-18, GR5	200-5-18-5	7-64	3
Nut, Hex, 5/8-11, GR5	200-10-11-5	7-8	38
Nut, Hex, 5/8-11, GR5	200-10-11-5	7-34	18
Nut, Hex, 5/8-11, GR5	200-10-11-5	7-35	18
Nut, Hex, 5/8-11, GR5	200-10-11-5	7-44	7
Nut, Hex, 5/8-11, GR5	200-10-11-5	7-67	7
Nut, Hex, 5/8-11, GR5	200-10-11-5	7-71	6
Nut, Hex, 7/16-14, GR5	200-7-14-5	7-27	12
Nut, Hex, 9/16-12, GR5	200-9-12-5	7-7	7
Nut, Hex, Heavy, 1/2-13, GR5	201-8-13-5	7-8	2
Nut, Hex, Heavy, 1/4-20, GR5	201-4-20-5	7-26	16
Nut, Hex, Heavy, 3/8-16, GR5	201-6-16-5	7-24	12
Nut, Hex, Jam 3/4-10, GR5	202-12-10-5	7-65	3
Nut, Hex, Jam 3/4-10, GR5	202-12-10-5	7-66	3
Nut, Hex, Jam, 1/2-13, GR5	204-8-13-5	7-7	32
Nut, Hex, Jam, 3/8-16, GR5	202-6-16-5	7-8	49
Nut, Hex, Jam, 3/8-16, GR5	202-6-16-5	7-33	8
Nut, Hex, M12x1.75, C8.8	200-M12-1.75-8.8	7-41	9
Nut, Hex, M12x1.75, C8.8	200-M12-1.75-8.8	7-50	8
Nut, Hex, Thick, 5/8-11, GR5	216-10-11-5	7-4	14
Nut, Jam, 7/8-9, GR5	202-14-9-5	7-34	30
Nut, Jam, 7/8-9, GR5	202-14-9-5	7-35	30
Nut, Jam, 7/8-9, GR5	202-14-9-5	7-47	9
Nut, Jam, 7/8-9, GR5	202-14-9-5	7-48	9
Nut, Lock, 3/8-16, GR5	200-6-16-5	7-42	19
Nut, Lock, 5/8-11, GR5	200-10-11-5	7-50	32
Nut, Lock, Flexloc, 5/8-11, Full, LT	217-10-11	7-52	16
Nut, Lock, Nylon, #10-32, GR5	205-#10-32-5	7-19	15
Nut, Lock, Nylon, 3/4-10, GR5	205-12-10-5	7-50	5
Nut, Lock, Stover, 1/2-13	204-8-13-5	7-43	7
Nut, Lock, Stover, 1/2-13, GR5	204-8-13-5	7-3	15
Nut, Lock, Stover, 1/2-13, GR5	204-8-13-5	7-4	8
Nut, Lock, Stover, 1/2-13, GR5	204-8-13-5	7-20	24
Nut, Lock, Stover, 1/2-13, GR5	204-8-13-5	7-34	38
Nut, Lock, Stover, 1/2-13, GR5	204-8-13-5	7-35	38
Nut, Lock, Stover, 1/2-13, GR5	204-8-13-5	7-47	53
Nut, Lock, Stover, 1/2-13, GR5	204-8-13-5	7-48	53
Nut, Lock, Stover, 1/4-20	204-4-20-5	7-43	5
Nut, Lock, Stover, 1/4-20, GR5	204-4-20-5	7-20	12

Alphabetical Parts Index

Description	Part No.	Figure No.	Item No.
Nut, Lock, Stover, 1/4-20, GR5	204-4-20-5	7-26	17
Nut, Lock, Stover, 1/4-20, GR5	204-4-20-5	7-27	23
Nut, Lock, Stover, 1/4-20, GR5	204-4-20-5	7-41	5
Nut, Lock, Stover, 1/4-20, GR5	204-4-20-5	7-44	19
Nut, Lock, Stover, 1/4-20, GR5	204-4-20-5	7-50	4
Nut, Lock, Stover, 1/4-20, GR5	204-4-20-5	7-67	19
Nut, Lock, Stover, 1-8, GR5	204-16-8-5	7-20	5
Nut, Lock, Stover, 3/8-16	204-6-16-5	7-74	3
Nut, Lock, Stover, 3/8-16	204-6-16-5	7-75	3
Nut, Lock, Stover, 3/8-16, GR5	204-6-16-5	7-4	33
Nut, Lock, Stover, 3/8-16, GR5	204-6-16-5	7-26	13
Nut, Lock, Stover, 3/8-16, GR5	204-6-16-5	7-32	24
Nut, Lock, Stover, 3/8-16, GR5	204-6-16-5	7-39	10
Nut, Lock, Stover, 3/8-16, GR5	204-6-16-5	7-40	10
Nut, Lock, Stover, 3/8-16, GR5	204-6-16-5	7-47	16
Nut, Lock, Stover, 3/8-16, GR5	204-6-16-5	7-48	16
Nut, Lock, Stover, 3/8-16, GR5	204-6-16-5	7-50	22
Nut, Lock, Stover, 3/8-16, GR5	204-6-16-5	7-52	29
Nut, Lock, Stover, 3/8-16, GR5	204-6-16-5	7-60	9
Nut, Lock, Stover, 3/8-16, GR5	204-6-16-5	7-61	9
Nut, Lock, Stover, 5/16-18, GR5	204-5-18-5	7-17	21
Nut, Lock, Stover, 5/16-18, GR5	204-5-18-5	7-44	16
Nut, Lock, Stover, 5/16-18, GR5	204-5-18-5	7-67	16
Nut, Lock, Stover, 5/8-11, GR5	204-10-11-5	7-4	28
Nut, Lock, Stover, 5/8-11, GR5	204-10-11-5	7-20	3
Nut, Lock, Stover, 5/8-11, GR5	204-10-11-5	7-27	30
Nut, Lock, Stover, 5/8-11, GR5	204-10-11-5	7-47	45
Nut, Lock, Stover, 5/8-11, GR5	204-10-11-5	7-48	45
Nut, Lock, Stover, 7/16-20, GR5	204-7-20-5	7-20	18
Nut, Nylon Lock, 7/8-9, GR5	205-14-9-5	7-58	15
Nut, Nylon Lock, 7/8-9, GR5	205-14-9-5	7-59	15
Nut, Nylon Lock, 7/8-9, GR5	205-14-9-5	7-65	7
Nut, Nylon Lock, 7/8-9, GR5	205-14-9-5	7-66	7
Nut, Hex, Jam, 1/2-13, GR5	202-8-13-5	7-6	26
Nylon Dust Cover	1015285	7-50	19
-O-			
Off Delay Timer, 5 Seconds	988231	7-45	14
Oil Cooler Deflector	1019430	7-18	1

Alphabetical Parts Index

Description	Part No.	Figure No.	Item No.
Oil Cooler Fan, Brushless	1018378-01	7-23	REF
Oil Cooler Heat Exchanger	1019123-01	7-23	REF
Oil Cooler Mounting Bracket	1016565	7-23	3
Oil Cooler Temperature Switch	1018378-03	7-23	REF
Oil Filter	986537-03	7-13	17
Option - 12" Auger Extension	985797SRV	7-71	OPT
Option - 24" Auger Extension w/Shield	982521SRV	7-72	OPT
OPTION - Adjustable Push Roller Assembly	1011041	7-3	OPT
OPTION - Automatic Temperature Controller	1017744	7-69	OPT
Option - Depth Screws, 3:1 Adjusters	1015263SRV	7-50	GRP
Option - Fire Extinguisher w/Bracket, 10 Lbs.	982031	7-78	5
Option - Fire Extinguisher w/Bracket, 2.50 Lbs.	360050	7-78	3
Option - Fire Extinguisher w/Bracket, 5 Lbs.	982030	7-78	4
Option - Hydraulic Tow Point		7-20	OPT
Option - TopCon P-32 Dual Grade/Slope	1014913SRV	7-76	GRP
Option - TopCon P-32, Dual Grade	1014912SRV	7-76	GRP
Option - Truck Hitch	1017214	7-77	OPT
Option - Umbrella w/Safety Decal	988347SRV	7-78	OPT
O-Ring, 3.237 ID x .103, SAE 152	36808	7-16	6
O-Ring, FKM/Viton, 75D, 3.737 ID x .103	12757410	7-16	16
O-Ring, Hydraulic Motor to Torque Hub	811366	7-1	20
O-Ring, Hydraulic Motor to Torque Hub	811366	7-2	25
Outer Conveyor Drive Sprocket	851474SRV	7-6	8
Outer Extension Assembly - Left	1007096SRV	7-34	31
Outer Extension Assembly - Right	1007098SRV	7-35	31
Outer Tube Pedestal Support Weldment	1017487	7-27	25
-P-			
P-32 Slope Module	1010499-09	7-76	21
Panel Mount Connector	1010657	7-29	25
Panel w/Notch	1007228-03	7-28	43
Panel w/Notch	1007228-03	7-29	41
Passenger Side Toeboard Weldment	1016551	7-18	16
PHMS, Cross, #10-24 x .5, FT	122-#10-24-8F	7-9	6
PHMS, Cross, #10-32 x 1.50, FT	122-#10-32-20F	7-19	13
PHMS, Cross, 1/4-20 x .50, FT	122-4-20-8F	7-69	7
Piloted Logic Element Valve	983643-06	7-21	9
Pin, 1/2 x 3.00 w/Cotter Pin	72836	7-30	5
Pin, Position Lock	1013870	7-74	9

Alphabetical Parts Index

Description	Part No.	Figure No.	Item No.
Pin, Position Lock	1013870	7-75	13
Pipe Bushing, 12MP-08FP, Steel	99985	7-53	26
Pipe, .75 x 1.00, SCH 80	854032	7-7	33
Pivot Bar	981659	7-57	8
Pivot Cover Plate	981711	7-32	3
Pivot Cover Plate	981711	7-57	9
Pivot Housing Tube	981660	7-32	4
Pivot Plate Weldment - Left	1015424SRV	7-32	7b
Pivot Plate Weldment - Right	1015412SRV	7-32	8b
Pivot Tube	1008917	7-39	5
Pivot Tube	1008917	7-40	5
Pivotbar Support Weldment	930015	7-77	1
Planetary Adapter Tube	1014924	7-50	27
Planetary Box Coupler	1014927	7-50	38
Planetary Drive Flight Screw Assembly - Left	1014929	7-50	REF
Planetary Drive Flight Screw Assembly - Right	1014928	7-50	REF
Planetary Drive Reduction Box	1014921	7-50	35
Planetary Threaded Rod	1014931	7-50	34
Plastic Hole Plug, .875, Flush Mount	35136-7	7-45	8
Plug Adapter, -10 O-Ring	6408-10-O	7-10	15
Plug Adapter, -16 O-Ring	6408-16-0	7-1	42
Plug Adapter, -16 O-Ring	6408-16-0	7-2	30
Plug Adapter, -4 O-Ring	6408-4-O	7-10	7
Plug Adapter, -6 O-Ring	6408-06-O	7-10	38
Plug Adapter, Hex Socket, -12 O-Ring	6409-12-O	7-10	36
Plug Adapter, Hex Socket, -6 O-Ring	6409-6-O	7-10	29
Plug Adapter, Hex Socket, -8 O-Ring	6409-8-O	7-10	26
Plug Adapter, Hex Socket, O-Ring, -6	6409-6-O	7-21	11
Plug Connector	989179	7-29	26
Plus 1 Controller, 50 Pin	1012975SRV	7-27	17
Poly Track Pad, 14"	851104	7-1	31
Polypad Track/Undercarriage Assembly - Left	1009741	7-1	REF
Polypad Track/Undercarriage Assembly - Right	1009742	7-1	REF
Power Block Relay	1009253-41	7-15	1
Power Cable, Ultrasonic	982796	7-42	23
Power Crown Adjuster Plate	1008600	7-53	5
Power Crown Center Weldment	1008667	7-53	6
Power Crown Composite Bushing	1000960	7-53	8
Power Crown Cover	1008168	7-53	1

7

Alphabetical Parts Index

Description	Part No.	Figure No.	Item No.
Power Crown Gauge Bar	1007232	7-53	29
Power Crown Harness	1009371	7-28	REF
Power Crown Harness	1009371	7-29	REF
Power Crown Hose Kit	1015123	7-53	REF
Power Crown Locking Collar	1000798	7-53	7
Power Crown Mounting Spacer	1006419	7-53	13
Power Crown Screed Cover - Right	988110	7-68	16
Power Crown Switch Mounting Plate	1008683	7-53	25
Power Crown w/Slope Harness	1008879	7-28	REF
Power Crown w/Slope Harness	1008879	7-29	REF
Pressure Sensor	1015438-02	7-19	3
Primary Air Filter	1009253-17	7-13	REF
Proof Coil Chain, .250 x 12 Link	920061-1	7-7	28
Proof Coil Chain, .312 x 36 Link	851143	7-7	8
Pump Isolator	1015089-05	7-19	5
Pump Servo Cover Gasket	851494	7-1	REF
Pump Servo Motor Gasket	851494	7-2	REF
Push Bar Roller Assembly w/Bearings	810102	7-77	13
Push Button Switch	982249	7-28	16
Push Button Switch	982249	7-29	13
Push Button Switch	982249	7-39	23
Push Button Switch	982249	7-40	23
Push Button Switch	982249	7-45	3
Push Lok Fitting, -5 LOC / -6 RFJX	5LOC-6RFJX	7-19	7
Push Lok Fitting, 90° Short, -6 FJX / -6 PL	33982-6-6	7-19	12
Push On Hose, .05,	71812	7-19	8
Push Roller Bearing, 1.250	810110	7-50	33
Push Roller Bearing, 1.250	810110	7-77	12
Push Roller Bearing, ø1.250	810110	7-41	11
Push Roller Weldment	1016888	7-3	1
Push/Pull Cable, 90" x 5" Stroke	851520	7-20	9
Pushbar Roller Assembly	980035	7-3	REF
Pushbar Roller Assembly, 24"	980033	7-3	REF
Pushbar Roller Extension Pipe	980036	7-3	6
Pushbar Roller Shaft	980034	7-3	5
Pushbar Swivel Pin	810081SRV	7-3	10
PV480 Display - V3874 T4F	1016158	7-28	3
PV480 Display - V3874 T4F	1016158	7-29	3

Alphabetical Parts Index

Description	Part No.	Figure No.	Item No.
-Q, R-			
Quick Release Pin	1008934	7-39	7
Quick Release Pin	1008934	7-40	7
Radial Ball Bearing, 1.50	930050	7-77	26
Radiator Cap	1002184-04	7-12	2
Radiator Deflector Assembly	1016486	7-17	2
Radiator Fan	1016478-01	7-12	6
Radiator Fan	1016478-01	7-13	12
Radiator Fan Guard	1005365-23	7-12	7
Radiator Mount Isolator	1001166-57	7-12	10
Radiator Support Bracket	1009384-18	7-12	9
Radiator/Cooler Assembly	988673-13	7-12	1
Rail Mount Plate	981656	7-57	14
Rail Mount Plate	981656	7-57	15
Rail Mount Weldment - Left	1008663SRV	7-32	7a
Rail Mount Weldment - Right	1008662SRV	7-32	8a
Rear Asphalt Blocker Plate	1015358	7-47	40
Rear Asphalt Blocker Plate	1015358	7-48	40
Rear Engine Mount	988673-14	7-13	15
Rear Side Access Cover	1016417	7-17	18
Rear Side Access Cover	1016417	7-18	17
Rear Tube Drive Assembly - Left	987712	7-6	1
Rear Tube Drive Assembly - Right	987713	7-6	2
Receptacle Connector, 31 Pin, HD34-24-31PT	981916	7-27	31
Receptacle, 19 Pin, HDP20 Series	1014909	7-27	36
Receptacle, 19 Pin, HDP20 Series	1014909	7-28	22
Receptacle, 19 Pin, HDP20 Series	1014909	7-29	20
Receptacle, 31 Pin, HD34-24-31ST	981916	7-28	25
Receptacle, 31 Pin, HD34-24-31ST	981916	7-29	23
Recovery Tank Bracket	1009384-08	7-12	14
Red Light	31983	7-45	10
Reducing Elbow	1009384-02	7-13	7
Relay Mounting Bracket	36086	7-28	33
Relay Mounting Bracket	36086	7-29	31
Relay, 12V, SPDT, 40A, 5 Pin	36085	7-28	34
Relay, 12V, SPDT, 40A, 5 Pin	36085	7-29	32
Relay, 12VDC, DSPT, 25A, N/O	985141	7-45	18
Relay, SPST, 75A	20934592	7-28	36
Relay, SPST, 75A	20934592	7-29	34

Alphabetical Parts Index

Description	Part No.	Figure No.	Item No.
Relief Valve, RV50-26A-0-P-50/27	1015402-03	7-22	23
Remote Pot, Ultrasonic	982795	7-42	22
Replacement Key	35560	7-17	REF
Replacement Key	35560	7-18	REF
Revolving Ball Knob, M12x1.75	981574	7-41	8
Revolving Ball Knob, M12x1.75	981574	7-50	7
Rheostat, 35 Ohm/25 Watt	1010077	7-28	12
Rheostat, 35 Ohm/25W	1010077	7-39	REF
Rheostat, 35 Ohm/25W	1010077	7-40	REF
Roll Pin, 1/4 x 1.25	400-4-20	7-8	20
Roll Pin, 3/16 x 2.25	400-3-36	7-8	51
Roll Pin, 3/8 x 2.00	400-6-32	7-5	13
Roll Up Curb Attachment, 12" (Left)	851635LSRV	7-73	REF
Roll Up Curb Attachment, 12" (Right)	851635RSRV	7-73	REF
Roll Up Curb Attachment, 24" (Left)	851636LSRV	7-73	3
Roll Up Curb Attachment, 24" (Right)	851636RSRV	7-73	4
Roller Chain Sprocket, #50	1000799	7-53	10
Roller Chain, 40 x 52 Pitch	870190	7-56	4
Roller Chain, 50x18	1000958	7-53	9
Roller Chain, 60H x 39 Pitches	1008047	7-53	12
Roller Chain, 60H x 39P w/Half-Link & Masterlink	1008047	7-33	23
Roller Chain, 60H x 51 Pitch	985815	7-8	27
Roller Chain, 80 x 56 Pitch	1019094	7-6	12
Roller Hose Guide Assembly	1016409	7-19	27
Roller Push Tube	980033-1	7-3	3
Roller Scraper - Large	1018310	7-3	9
Roller Scraper - Small	1018311	7-3	8
Roller Scraper Bracket - Large	1018312	7-3	7
Round Ball Knob, 3/8-16 x 1.375	851156	7-50	23
Round Knob, 1.375 x 3/8-16	851156	7-39	6
Round Knob, 1.375 x 3/8-16	851156	7-40	6
Round Tube	856854	7-77	11
Round Tube	856855	7-77	21
Round Tube Assembly	930040	7-77	REF
Round, .688 x 43.50, CRS	854447SRV	7-58	8
Round, .688 x 43.50, CRS	854447SRV	7-59	8
Round, .688 x 43.50, CRS	854447SRV	7-60	10
Round, .688 x 43.50, CRS	854447SRV	7-61	10
Rubber Track Sprocket (Comer)	1009464	7-2	17

Alphabetical Parts Index

Description	Part No.	Figure No.	Item No.
Rubber Track/Undercarriage Assembly - Left	1009873	7-2	REF
Rubber Track/Undercarriage Assembly - Right	1009874	7-2	REF
Run Tee Adapter, -10 ORFS/-12 O-Ring/-10 ORFS	FS6804-10-12-10-NWO-FG	7-25	7
Run Tee Adapter, -12 ORFS/ -16 O-Ring/ -12 ORFS	FS6804-12-16-12-NWO-FG	7-23	5
Run Tee Adapter, -6 ORFS (x3)	FS6804-06-06-06-NWO-FG	7-10	8
Run Tee Adapter, -8 ORFS (x3)	FS6804-08-08-08-NWO-FG	7-10	9
Run Tee Bulkhead Adapter, -12 ORFS (x3)	FS2704-12-12-12-FG	7-1	52
Run Tee Bulkhead Adapter, -12 ORFS (x3)	FS2704-12-12-12-FG	7-2	39
Run Tee Bulkhead Adapter, -4 ORFS (x3)	FS2704-04-04-04-FG	7-1	50
Run Tee Bulkhead Adapter, -4 ORFS (x3)	FS2704-04-04-04-FG	7-2	37
Run Tee Bulkhead Adapter, -6 JIC / -6 JIC / -6	2704-6-6-6-LN	7-19	11
RV08 Relief Valve	983643-07	7-21	8

-S-

Safety Edge Depth Screw Bracket - Left	1011206	7-52	2a
Safety Edge Depth Screw Bracket - Right	1011205	7-52	2b
Safety Edge Spring Mechanism	1011453	7-52	13
Screed Arm Weldment, Adjustable - Left	1017801	7-39	1
Screed Arm Weldment, Adjustable - Right	1017802	7-40	1
Screed Base Element Cover	985124	7-56	6
Screed Base Element Cover	985124	7-57	7
Screed Bulkhead Union Adapter	1015947	7-47	49
Screed Bulkhead Union Adapter	1015947	7-48	49
Screed Control Box Assembly, 9 Function - Right	1017792	7-40	16
Screed Control Box Assembly, 9 Function - Left	1017791	7-39	16
Screed Control Box Mount	1017803	7-39	4
Screed Control Box Mount	1017803	7-40	4
Screed Control Box, 4 Switch - Left	1016618	7-37	5
Screed Control Box, 4 Switch - Left	1016618	7-63	9
Screed Control Box, 4 Switch - Right	1016617	7-38	5
Screed Control Box, 4 Switch - Right	1016617	7-64	9
Screed Cover Plate - Left	985148	7-57	20
Screed Cover Plate - Right	985147	7-57	19
Screed Cover Weldment	1011697	7-32	29
Screed Depth Screw Assembly	890092SRV	7-65	2
Screed Depth Screw Assembly	890092SRV	7-66	2
Screed Extension Assembly - Left	1006378SRV	7-34	REF
Screed Extension Assembly - Right	1006379SRV	7-35	REF
Screed Extension Bottom Rail	855783	7-56	10

Alphabetical Parts Index

Description	Part No.	Figure No.	Item No.
Screed Extension Clamp, Element	985123	7-59	11
Screed Extension Cylinder Cover - Left	851204SRV	7-56	15
Screed Extension Cylinder Cover - Right	851203SRV	7-56	16
Screed Extension Element Clam	985123	7-61	13
Screed Extension Element Clamp	985123	7-34	9
Screed Extension Element Clamp	985123	7-35	9
Screed Extension Element Clamp	985123	7-47	32
Screed Extension Element Clamp	985123	7-48	32
Screed Extension Element Clamp	985123	7-58	11
Screed Extension Element Clamp	985123	7-60	13
Screed Extension Front Assembly - Left	1009632	7-34	1
Screed Extension Front Assembly - Right	1009631	7-35	1
Screed Extension Hinge Guard - Left	851180LSRV	7-58	16
Screed Extension Hinge Guard - Left	851180LSRV	7-60	15
Screed Extension Hinge Guard - Right	851180RSRV	7-59	16
Screed Extension Hinge Guard - Right	851180RSRV	7-61	15
Screed Extension Top Rail	855784	7-56	11
Screed Flight Screw Bearing	870030	7-58	5
Screed Flight Screw Bearing	870030	7-59	5
Screed Flight Screw Bearing	870030	7-60	5
Screed Flight Screw Bearing	870030	7-61	5
Screed Flight Screw Bearing	870030	7-63	19
Screed Flight Screw Bearing	870030	7-64	19
Screed Front Pull Arm	851206SRV	7-20	1
Screed Lid Cover	985149	7-57	18
Screed Lift Cylinder Assembly	1019251	7-25	REF
Screed Lift Cylinder, 2.50 x 12.00 x 1.00	1014284SRV	7-25	15
Screed Plate Access Cover	851201SRV	7-56	14
Screed Pull Arm Assembly - Left	984897SRV	7-63	1
Screed Pull Arm Assembly - Right	984896SRV	7-64	1
Screed Pull Arm Pivot Ears	851210	7-20	6
Screed Pull Arm Pivot Mount	851209	7-20	13
Screed Slide Bar Jack	988556	7-56	12
Screed Thickness Adjuster Assembly	1011374SRV	7-41	REF
Seal Kit, Track Tensioner Cylinder	811331-01	7-1	REF
Seal Kit, Track Tensioner Cylinder	811331-01	7-2	REF
Seal, Hydraulic Drive Motor	59941203	7-1	21
Seal, Hydraulic Drive Motor	59941203	7-2	26
Seat Assembly w/Short Post	1016967	7-30	REF

Alphabetical Parts Index

Description	Part No.	Figure No.	Item No.
Seat Post Assembly - Short	988640SRV	7-30	2
Secondary Air Filter	38385-02	7-13	REF
Selector Valve Berm Remote Assembly	1017180	7-49	REF
Self-Drilling Screw, Hex Washer Head, #10 x 1.00	116-#10-16	7-9	9
Self-Drilling Screw, Hex Washer Head, #10 x 1.00	116-#10-16	7-10	23
Set Screw, 3/8-16 x .75, Knurl Cup Point	1017379	7-8	42
Set Screw, HSKT, Cup, 3/8-16 x .375	113-6-16-6	7-50	37
Set Screw, HSKT, Cup, 3/8-16 x .75	113-6-16-12	7-51	6
Set Screw, HSKT, Cup, 3/8-16 x .75	113-6-16-12	7-52	9
Shaft Seal, 1.25 ID x 2.00 OD	1014930	7-50	20
Shaft w/Sprocket, 12" Auger	1007270SRV	7-8	33
Shaft, 3/8 CR x 1-1/2	855496	7-37	3
Shaft, 3/8 CR x 1-1/2	855496	7-38	3
Shaft, 3/8 CR x 1-1/2	855496	7-39	3
Shaft, 3/8 CR x 1-1/2	855496	7-40	3
Shaft, ø.688 x 43.50	854447SRV	7-34	2
Shaft, ø.688 x 43.50	854447SRV	7-35	2
Shoudler Bolt, 1/2 x 2L, 3/8 x 16	118-8-32-3/8x16	7-61	7
Shoulder Bolt, 1/2 x 2L, 3/8 x 16	118-8-32-3/8x1	7-58	6
Shoulder Bolt, 1/2 x 2L, 3/8 x 16	118-8-32-3/8x1	7-59	6
Shoulder Bolt, 1/2 x 2L, 3/8 x 16	118-8-32-3/8x16	7-60	7
Shoulder Bolt, ø1/2 x 2.5L, 3/8-16	118-8-40-3/8x16	7-47	42
Shoulder Bolt, ø1/2 x 2.5L, 3/8-16	118-8-40-3/8x16	7-48	42
Shoulder Bolt, ø1/2 x 2L, 3/8-16	118-8-32-3/8x16	7-47	15
Shoulder Bolt, ø1/2 x 2L, 3/8-16	118-8-32-3/8x16	7-48	15
Shoulder Bolt, ø3/4 x 1.75L, 5/8-11	118-12-28-5/8x11	7-34	16
Shoulder Bolt, ø3/4 x 1.75L, 5/8-11	118-12-28-5/8x11	7-35	16
Shoulder Bolt, ø3/4 x 1.75L, 5/8-11	118-12-28-5/8x11	7-47	48
Shoulder Bolt, ø3/4 x 1.75L, 5/8-11	118-12-28-5/8x11	7-48	48
Shoulder Bolt, ø3/4 x 2.5L, 5/8-11	118-12-40-5/8x11	7-47	43
Shoulder Bolt, ø3/4 x 2.5L, 5/8-11	118-12-40-5/8x11	7-48	43
Side Access Door Assembly - Left	1016468	7-17	REF
Side Access Door Assembly - Right	1016416	7-18	REF
Side Planetary Mount Plate	1014923	7-50	28
Side Strip Flashing	985062	7-7	19
Sidewing Rubber	980728	7-7	3
Ski, 20', Front	985190	7-74	10
Ski, 20', Rear	985191	7-74	17
Skid	851249SRV	7-74	1

7

Alphabetical Parts Index

Description	Part No.	Figure No.	Item No.
Slide Adjust Assembly	985556SRV	7-60	4
Slide Adjustment Assembly	985556SRV	7-61	4
Slide Locking Bar	1006424	7-32	9a
Slide Plate Assembly	1002181	7-62	2
Slide Plate Assembly w/Chrome Rods	1002186	7-62	1
Slope Module Cable (8 ft.)	1010499-10	7-76	22
Slope Pin	981659	7-32	6
Slope Pivot Poly Bushing	981838	7-32	5
SLP Screed Arm Assembly - Left	1006437SRV	7-37	1
SLP Screed Arm Assembly - Right	1006438SRV	7-38	1
SMS Test Hose Assembly w/#4 Female JIC - 24"	1013588-24	7-11	REF
SMS Test Hose Assembly w/#4 Female JIC - 96"	1013588-96	7-11	REF
Snap Ring	851256	7-62	5
Sonic Sensor Bracket Weldment	1015380	7-42	14
Sonic Sensor Bracket Weldment	1015380	7-51	19
Sonic Sensor Bracket Weldment	1015380	7-52	24
Sonic Sensor Mount	1008905	7-42	16
Sonic Sensor Mount	1008905	7-51	21
Sonic Sensor Mount	1008905	7-52	26
Sonic Tracker II Assembly	1010499-06	7-76	15
Spiral Internal Spring, 2.00 ID Shaft	980380	7-36	4
Spirol Pin, ø3/8 x 1.75	20160644	7-41	18
Spirol Pin, ø3/8 x 1.750	20160644	7-50	36
Spray Down Pump Body	1015438-01	7-19	2
Spray Down Pump w/Pressure Switch	1015438	7-19	REF
Spray Down Pump Weldment	1016580	7-19	16
Spray Down Reel w/Hose	920200	7-19	1
Spray Down System Assembly	1017031	7-19	REF
Spring Loaded Pull Pin	1000835	7-27	14
Spring, Extension	851245	7-74	4
Spring, Extension	851245	7-75	5
Sprocket, 40 Roller 12T	986641	7-68	2
Sprocket, 60B 14 x 1-6 Spline	860030	7-8	26
S-Style Element Cover	1016477	7-33	6
S-Style Element End Cover - Left	1016483	7-33	12
S-Style Element End Cover - Right	1016481	7-33	11
S-Style Element Hold Down Bar	1016476	7-33	10
S-Style Element Stop Bar	1016480	7-33	9
S-Style Heating Element, 2000W/240V	1015016	7-33	3

Alphabetical Parts Index

Description	Part No.	Figure No.	Item No.
Starter	1001166-03	7-14	1
Steel Track/Undercarriage Assembly - Left	1009738	7-1	REF
Steel Track/Undercarriage Assembly - Right	1009739	7-1	REF
Steering Wheel Box	1000708	7-70	1
Straight Adapter, -10 ORFS/ -12 O-Ring	FS6400-10-12-O	7-24	5
Straight Adapter, -10 ORFS/-10 O-Ring	FS6400-10-10-O	7-16	2
Straight Adapter, -10 ORFS/-10 O-Ring	FS6400-10-10-O	7-22	11
Straight Adapter, -10 ORFS/-12 O-Ring	FS6400-10-12-O	7-10	28
Straight Adapter, -10 ORFS/-12 O-Ring	FS6400-10-12-O	7-22	17
Straight Adapter, -12 ORFS/-12 ORFS	FS6400-12-12-O	7-1	43
Straight Adapter, -12 ORFS/-12 ORFS	FS6400-12-12-O	7-2	31
Straight Adapter, -12 ORFS/-16 O-Ring	FS6400-12-16-O	7-12	3
Straight Adapter, -12 ORFS/-16 O-Ring	FS6400-12-16-O	7-16	11
Straight Adapter, -12 ORFS/-8 O-Ring	FS6400-12-08-O	7-22	10
Straight Adapter, -16 ORFS/-16 O-Ring	FS6400-16-16-O	7-16	3
Straight Adapter, -16 ORFS/-20 O-Ring	FS6400-16-20-O	7-10	5
Straight Adapter, -4 ORFS/-4 O-Ring	FS6400-04-04-O	7-22	1
Straight Adapter, -4 ORFS/-8 O-Ring	FS6400-04-08-O	7-77	32
Straight Adapter, -6 BSPP / -6 NPT	1015089-04	7-19	4
Straight Adapter, -6 ORFS/ -6 O-Ring	FS6400-06-06-O	7-24	3
Straight Adapter, -6 ORFS/-4 NPTF	FS2404-06-04	7-7	38
Straight Adapter, -6 ORFS/-6 O-Ring	FS6400-06-06-O	7-10	27
Straight Adapter, -6 ORFS/-6 O-Ring	FS6400-06-06-O	7-10	37
Straight Adapter, -6 ORFS/-6 O-Ring	FS6400-6-6-O	7-21	12
Straight Adapter, -6 ORFS/-6 O-Ring	FS6400-06-06-O	7-22	9
Straight Adapter, -6 ORFS/-6 O-Ring	FS6400-06-06-O	7-25	2
Straight Adapter, -6 ORFS/-6 O-Ring w/.060 Orifice	FS6400-6-6-O X 060	7-21	13
Straight Adapter, -8 ORFS/ -12 O-Ring	FS6400-08-12-O	7-24	4
Straight Adapter, -8 ORFS/-10 O-Ring	FS6400-08-10-O	7-6	27
Straight Adapter, -8 ORFS/-10 O-Ring	FS6400-08-10-O	7-8	24
Straight Adapter, -8 ORFS/-12 O-Ring	FS6400-08-12-O	7-22	3
Straight Adapter, -8 ORFS/-8 O-Ring	FS6400-08-08-O	7-10	35
Straight Adapter, -8 ORFS/-8 O-Ring	FS6400-08-08-O	7-22	7
Straight Fitting, 04MP-05HB Crimped	33491	7-9	4
Straight Fitting, 06MP-06FPX	6274	7-44	10
Straight Fitting, 06MP-06FPX	6274	7-67	10
Straight Fitting, 06MP-06HB, Push On	31959	7-44	8
Straight Fitting, 06MP-06HB, Push On	31959	7-67	8
Straight Lube Fitting, 1/4-28	140610	7-63	20

Alphabetical Parts Index

Description	Part No.	Figure No.	Item No.
Straight Lube Fitting, 1/4-28	140610	7-64	20
Straight Reducer Adapter, -10 FFORX/-4 ORFS	FS2406-10-04	7-25	8
Straight Reducer Adapter, -12 FFORX/-10 ORFS	FS2406-12-10	7-1	55
Straight Reducer Adapter, -12 FFORX/-10 ORFS	FS2406-12-10	7-2	42
Strike Off, 12" (Left)	860091LSRV	7-73	1
Strike Off, 12" (Right)	860091RSRV	7-73	2
Strike Off, 24" (Left)	860095LSRV	7-73	REF
Strike Off, 24" (Right)	860095RSRV	7-73	REF
Swivel Bulkhead Union Adapter	1015947	7-53	33
Swivel Elbow Adapter, 90°, -12 ORFS/-12 ORFS	FS6500-12-12-FG	7-1	53
Swivel Elbow Adapter, 90°, -12 ORFS/-12 ORFS	FS6500-12-12-FG	7-2	40
Swivel Elbow Adapter, 90°, -4 ORFS/-4 ORFS	FS6500-04-04-FG	7-77	33
Swivel Run Tee Adapter, -12 ORFS (x3)	FS6602-12-12-12-FG	7-1	54
Swivel Run Tee Adapter, -12 ORFS (x3)	FS6602-12-12-12-FG	7-2	41
Swivel Run Tee Adapter, -12 ORFS/-12 ORFS/-12 ORFS	FS6602-12-12-12-FG	7-12	5
Swivel Straight Adapter, -12 ORFS/-12 O-Ring	FS6540-12-12-O	7-22	15
-T-			
Tail Pipe	1011364	7-14	8
Tandem Hydraulic Pump, 31.8 CC/25.1 CC, 13T, B	1016845	7-16	17
Tandem Hydraulic Pump, H1 w/EDC, w/o Charge	1009527	7-16	9
Temp Bail w/Sleeves Assembly	1010499-07	7-76	16
Temperature Controller, Watlow PM6	1017392	7-69	4
Terminal Block w/Cover	985138-04	7-45	17
Test Point Coupling, -4 O-Ring	DP6400-04-O	7-22	2
Test Port Bracket	1013805	7-11	1
Thickness Adjuster Handle Weldment	1011375SRV	7-41	1
Thickness Adjuster Shaft	1011307	7-41	15
Thickness Weldment	1014115	7-50	10
Thimble, Cable, .063	1013865	7-74	7
Thimble, Cable, .063	1013865	7-75	8
Thumb Screw, 3/8-16 x 1.00	920070	7-7	17
Thumb Screw, 3/8-16 x 1.00	920070	7-42	15
Thumb Screw, 3/8-16 x 1.00	920070	7-51	20
Thumb Screw, 3/8-16 x 1.00	920070	7-52	25
Thumb Screw, 3/8-16 x 1.00	920070	7-76	4
Thumb Screw, 3/8-16 x 1.00	920070	7-74	14
Thumb Screw, 3/8-16 x 1.00	920070	7-75	18
Tilt Screw	890081SRV	7-42	10

Alphabetical Parts Index

Description	Part No.	Figure No.	Item No.
Tilt Screw	890081SRV	7-51	14
Tilt Screw	890081SRV	7-52	20
Tilt Screw Retainer Bar	980458	7-42	8
Tilt Screw Retainer Bar	980458	7-51	12
Tilt Screw Retainer Bar	980458	7-52	18
Tilt Screw Swivel Shaft	980457	7-42	9
Tilt Screw Swivel Shaft	980457	7-51	13
Tilt Screw Swivel Shaft	980457	7-52	19
Time Delay Relay, ON, 10A	988230	7-45	12
Toggle Switch	851393	7-28	18
Toggle Switch	851393	7-29	16
Toggle Switch	851393	7-37	14
Toggle Switch	851393	7-38	14
Toggle Switch	851393	7-63	12
Toggle Switch	851393	7-64	12
Toggle Switch Mounting Bracket	1016260	7-28	32
Toggle Switch Mounting Bracket	1016260	7-29	30
Toggle Switch Weather Boot	851440	7-49	6
Toggle Switch, 2-POS	851391	7-37	13
Toggle Switch, 2-POS	851391	7-38	13
Toggle Switch, 2-POS	851391	7-39	17
Toggle Switch, 2-POS	851391	7-40	17
Toggle Switch, 2-POS	851391	7-63	11
Toggle Switch, 2-POS	851391	7-64	11
Toggle Switch, 2-POS, SPST	851391	7-28	9
Toggle Switch, 2-POS, SPST	851391	7-29	9
Toggle Switch, 3-POS, DPDT	851390	7-28	17
Toggle Switch, 3-POS, DPDT	851390	7-29	14
Toggle Switch, 3-POS, DPDT, MOM	37521	7-28	10
Toggle Switch, 3-POS, DPDT, MOM	37521	7-29	10
Toggle Switch, 3-POS, SPDT	851090613	7-28	13
Toggle Switch, 3-POS, SPDT	851090613	7-29	15
Toggle Switch, 3-POS, SPDT, MOM	851392	7-28	8
Toggle Switch, 3-POS, SPDT, MOM	851392	7-29	8
Toggle Switch, 3-POS, SPDT, MOM	851392	7-37	12
Toggle Switch, 3-POS, SPDT, MOM	851392	7-38	12
Toggle Switch, 3-POS, SPDT, MOM	851392	7-39	18
Toggle Switch, 3-POS, SPDT, MOM	851392	7-40	18
Toggle Switch, 3-POS, SPDT, MOM	851392	7-63	10

Alphabetical Parts Index

Description	Part No.	Figure No.	Item No.
Toggle Switch, 3-POS, SPDT, MOM	851392	7-64	10
Toggle Switch, Auto Conveyor	900030	7-28	14
Toggle Switch, Auto Conveyor	900030	7-29	12
Toggle Switch, DPDT, 3-POS, MOM	37521	7-39	22
Toggle Switch, DPDT, 3-POS, MOM	37521	7-40	22
Toggle Switch, SPDT, 2-POS	851090624	7-45	2
Toggle Switch, SPDT, 3-POS	851090613	7-39	20
Toggle Switch, SPDT, 3-POS	851090613	7-40	21
Toggle Switch, SPST, 2-POS	851391	7-49	9
Toggle Switch, SPST, 2-POS	851391	7-53	20
Tongued Washer, 1.21 ID x 1.86 OD	20931333	7-41	12
Tongued Washer, 1.21 ID x 1.86 OD	20931333	7-50	39
Tool Box	853963	7-30	6
Tool Tray Assembly	1016514	7-44	12
Tool Tray Assembly	1016514	7-67	12
Top Access Door	1016548	7-17	19
Top Access Hole Cover	1016425	7-18	18
Top Asphalt Blocker Plate - Left	1015374	7-47	25
Top Asphalt Blocker Plate - Right	1015359	7-48	25
Top Hydraulic Tank Assembly	1019242	7-10	REF
Top Planetary Mounting Plate	1014922	7-50	12
Top Rail Bar	981657	7-57	17
TopCon Grade Control Wiring Option	1017796SRV	7-76	REF
TopCon P-32 Kit	1010499	7-76	13
TopCon Sonic Tracker Bracket	851578	7-76	7
TopCon Z-Arm Bracket	9090-1125SRV	7-76	1
TopCon/Spectra Pivot Mount	851575SRV	7-76	2
Torque Hub w/Disconnect (Comer)	1008779	7-1	19
Torque Hub w/Disconnect (Comer)	1008779	7-2	18
Tow Point Manifold w/Flow Control	1016687	7-20	REF
Track Assembly w/Cast Steel Pads	851101	7-1	REF
Track Assembly w/Polypads	851101P	7-1	1
Track Chain Link - Left	853194	7-1	33
Track Chain Link - Right	853195	7-1	32
Track Chain Master Pin Washer	811305	7-1	37
Track Idler	1001589	7-1	4
Track Link Bushing Spacer	811310	7-1	39
Track Link Pin	811307	7-1	34
Track Link Short Bushing	851460	7-1	38

Alphabetical Parts Index

Description	Part No.	Figure No.	Item No.
Track Pad Bolt Nut	811309	7-1	41
Track Pad Hex Bolt	811308	7-1	40
Track Roller, B/O	811326	7-1	12
Track Roller, B/1, Inner Flange	983588	7-2	12
Track Roller, B/1, N/S	851566	7-1	13
Track Sprocket (Comer)	1006737	7-1	18
Track Tensioner Cylinder Breather	851644	7-1	8
Track Tensioner Cylinder Breather	851644	7-2	8
Track Tensioner Hose Kit	1016860	7-1	REF
Track Tensioner Hose Kit	1016860	7-2	REF
Track Tensioner Manifold	851544	7-10	31
Truck Hitch Assembly w/Counter-Weight	1008796	7-77	REF
Truck Hitch Cover	930065SRV	7-77	4
Truck Hitch Extension Arm - Left	930025SRV	7-77	2
Truck Hitch Extension Arm - Right	930020SRV	7-77	3
Truck Hitch Hose Kit	1019160	7-77	34
Truck Hitch Hydraulic Cylinder Assembly	1019876	7-77	REF
Truck Hitch Option - Valving Only	1017213	7-77	30
Truck Hitch Roller Assembly Shaft	930075	7-77	10
Truck Hitch Valve	852250	7-77	31
Truck Hitch Valve Assembly w/Adapters	1019168	7-77	REF
Truck Hitch Wheel Weldment	930030SRV	7-77	17
Tube, Ski Foot Mount	982005SRV	7-75	4
Tuck Hitch Roller Assembly	930060	7-77	REF
Turnbuckle Assembly	986637SRV	7-68	10
-U, V-			
Ultra Sonic Remote Pod	982795	7-65	14
Ultra Sonic Remote Pod	982795	7-66	14
Ultra Sonic Sensor	982794	7-65	16
Ultra Sonic Sensor	982794	7-66	16
Ultrasonic Power Cable	982796	7-65	13
Ultrasonic Power Cable	982796	7-66	13
Umbrella w/Mounting Brackets	920235	7-78	1
Undercarriage Assembly - Left	1009467	7-2	2b
Undercarriage Assembly - Right	1009468	7-2	2a
Undercarriage Roller	851566	7-2	12
Undercarriage Weldment - Left	1008788	7-1	3b
Undercarriage Weldment - Left	1009465	7-2	3b

Alphabetical Parts Index

Description	Part No.	Figure No.	Item No.
Undercarriage Weldment - Right	1008789	7-1	3a
Undercarriage Weldment - Right	1009466	7-2	3a
Union Adapter, -8 O-Ring/-8 O-Ring	6407-8-8 NWO	7-10	32
Union Tee Adapter, -4 ORFS/-4 ORFS/-4 ORFS	FS2603-04-04-04	7-1	47
Union Tee Adapter, -4 ORFS/-4 ORFS/-4 ORFS	FS2603-04-04-04	7-2	34
Universal Joint	21426507	7-41	17
Universal Joint	21426507	7-50	43
Universal Joint Bearing	20960332	7-41	REF
Universal Joint Bearing	20960332	7-50	REF
Upper Asphalt Shield Spring	1015173	7-32	23
Upper Manifold Assembly w/ ORFS Adapters	1019164	7-21	GRP
Upper Manifold, 9-Station	983643-13	7-21	1
Upper Planetary Drive Shaft	1014925	7-50	11
Upper Radiator Hose	1006963-15	7-12	11
Upper Screed Cover - Left	1006405	7-32	13
Upper Screed Cover - Right	1006406	7-32	14
Valve	989656	7-68	15
Valve Driver, EGDR-0101A, 10 kW Gen Controller	1018639	7-22	13
Valve, PV70-33C-0-N-00	1017450-02	7-22	26
Valve, SP12-21AP-0-N-0-E	1016083-02	7-22	20
Valve, SV08-30-0-N-00	1006953-09	7-22	24
Valve, SV12-23P-0-N-00	983644-02	7-22	22
Vandalism Cover Assembly	1007339	7-26	3
Vandalism Cover Spacer	1007338	7-26	19
Vandalism Latch Bar	1007337	7-26	2
Vertical Adjuster Assembly	1006390	7-34	3
Vertical Adjuster Assembly	1006390	7-35	3
Vertical Adjustment Assembly	1006390	7-47	11
Vertical Adjustment Assembly	1006390	7-48	11
Vertical Lift Bar	1006395	7-34	35
Vertical Lift Bar	1006395	7-35	35
Vertical Lift Bar	1006395	7-47	50
Vertical Lift Bar	1006395	7-48	50
Vibrator Motor, 12VDC, DC-60AL	1018588	7-43	1
Vibrator Motor, 12VDC, DC-60AL	1018588	7-53	31
Vibrator Mount Weldment	1015435SRV	7-47	59
Vibrator Mount Weldment	1015423SRV	7-48	59
Vinyl Cap, Black	984862	7-30	REF

Alphabetical Parts Index

Description	Part No.	Figure No.	Item No.
-W-			
Walkboard Assembly w/Extensions	987056SRV	7-43	16
Walkboard Hinge Plate	985163	7-43	10
Wash Down Handle & Nozzle	920220	7-19	30
Wash Down Nozzle	901210A	7-19	REF
Washer	851112	7-77	27
Washer, .50 ID x 2.00 OD	1017118	7-3	19
Washer, Connector, HDP20 Series	1011855	7-27	35
Washer, Fender, 3/8 x 1.50	308-6-24	7-12	16
Washer, Flat, .688 x 2.25 x .188	1012165	7-3	13
Washer, Flat, 5/8	300-10	7-47	44
Washer, Flat, 5/8	300-10	7-48	44
Washer, Flat, Fender, 1/4 x 1.00	308-4-16	7-6	21
Washer, Flat, Fender, 3/8 x 1.50	308-6-24	7-20	16
Washer, Flat, SAE, #10	300-#10	7-19	14
Washer, Flat, SAE, 1/2	300-8	7-1	16
Washer, Flat, SAE, 1/2	300-8	7-4	9
Washer, Flat, SAE, 1/2	300-8	7-6	44
Washer, Flat, SAE, 1/2	300-8	7-7	31
Washer, Flat, SAE, 1/2	300-8	7-8	16
Washer, Flat, SAE, 1/2	300-8	7-16	15
Washer, Flat, SAE, 1/2	300-8	7-23	15
Washer, Flat, SAE, 1/2	300-8	7-34	37
Washer, Flat, SAE, 1/2	300-8	7-35	37
Washer, Flat, SAE, 1/2	300-8	7-47	14
Washer, Flat, SAE, 1/2	300-8	7-47	52
Washer, Flat, SAE, 1/2	300-8	7-48	14
Washer, Flat, SAE, 1/2	300-8	7-48	52
Washer, Flat, SAE, 1/2	300-8	7-53	16
Washer, Flat, SAE, 1/2	300-8	7-62	7
Washer, Flat, SAE, 1/4	300-4	7-19	29
Washer, Flat, SAE, 1/4	300-4	7-26	15
Washer, Flat, SAE, 1/4	300-4	7-27	22
Washer, Flat, SAE, 1/4	300-4	7-41	4
Washer, Flat, SAE, 1/4	300-4	7-43	4
Washer, Flat, SAE, 1/4	300-4	7-44	18
Washer, Flat, SAE, 1/4	300-4	7-50	3
Washer, Flat, SAE, 1/4	300-4	7-67	18
Washer, Flat, SAE, 1/4	300-4	7-69	9

Alphabetical Parts Index

Description	Part No.	Figure No.	Item No.
Washer, Flat, SAE, 3/4	300-12	7-34	17
Washer, Flat, SAE, 3/4	300-12	7-35	17
Washer, Flat, SAE, 3/4	300-12	7-76	9
Washer, Flat, SAE, 3/8	300-6	7-3	18
Washer, Flat, SAE, 3/8	300-6	7-6	17
Washer, Flat, SAE, 3/8	300-6	7-7	10
Washer, Flat, SAE, 3/8	300-6	7-8	55
Washer, Flat, SAE, 3/8	300-6	7-17	15
Washer, Flat, SAE, 3/8	300-6	7-18	14
Washer, Flat, SAE, 3/8	300-6	7-23	12
Washer, Flat, SAE, 3/8	300-6	7-24	13
Washer, Flat, SAE, 3/8	300-6	7-26	12
Washer, Flat, SAE, 3/8	300-6	7-32	21
Washer, Flat, SAE, 3/8	300-6	7-34	8
Washer, Flat, SAE, 3/8	300-6	7-35	8
Washer, Flat, SAE, 3/8	300-6	7-39	9
Washer, Flat, SAE, 3/8	300-6	7-40	9
Washer, Flat, SAE, 3/8	300-6	7-42	18
Washer, Flat, SAE, 3/8	300-6	7-47	7
Washer, Flat, SAE, 3/8	300-6	7-48	7
Washer, Flat, SAE, 3/8	300-6	7-50	18
Washer, Flat, SAE, 3/8	300-6	7-51	23
Washer, Flat, SAE, 3/8	300-6	7-52	28
Washer, Flat, SAE, 5/16	300-5	7-8	9
Washer, Flat, SAE, 5/16	300-5	7-19	19
Washer, Flat, SAE, 5/16	300-5	7-23	9
Washer, Flat, SAE, 5/16	300-5	7-27	39
Washer, Flat, SAE, 5/16	300-5	7-30	14
Washer, Flat, SAE, 5/16	300-5	7-37	11
Washer, Flat, SAE, 5/16	300-5	7-38	11
Washer, Flat, SAE, 5/16	300-5	7-39	14
Washer, Flat, SAE, 5/16	300-5	7-40	14
Washer, Flat, SAE, 5/16	300-5	7-44	15
Washer, Flat, SAE, 5/16	300-5	7-47	57
Washer, Flat, SAE, 5/16	300-5	7-48	57
Washer, Flat, SAE, 5/16	300-5	7-50	15
Washer, Flat, SAE, 5/16	300-5	7-63	5
Washer, Flat, SAE, 5/16	300-5	7-64	5
Washer, Flat, SAE, 5/16	300-5	7-67	15

Alphabetical Parts Index

Description	Part No.	Figure No.	Item No.
Washer, Flat, SAE, 5/8	300-10	7-8	30
Washer, Flat, SAE, 5/8	300-10	7-20	8
Washer, Flat, SAE, 5/8	300-10	7-27	29
Washer, Flat, SAE, 5/8	300-10	7-50	30
Washer, Flat, SAE, 5/8	300-10	7-52	15
Washer, Flat, SAE, 5/8	300-10	7-76	6
Washer, Flat, SAE, 7/16	300-7	7-7	23
Washer, Flat, SAE, 7/16	300-7	7-27	10
Washer, Flat, SAE, 7/8	300-14	7-34	29
Washer, Flat, SAE, 7/8	300-14	7-35	29
Washer, Flat, SAE, M10	300-M10	7-1	36
Washer, Flat, SAE, M10	300-M10	7-16	8
Washer, Flat, SAE, M12	300-M12	7-16	24
Washer, Flat, SAE, M16	300-M16	7-13	22
Washer, Flat, USS, 1/2	301-8	7-4	6
Washer, Flat, USS, 1/2	301-8	7-8	4
Washer, Flat, USS, 3/4	301-12	7-41	7
Washer, Flat, USS, 3/4	301-12	7-50	6
Washer, Flat, USS, 3/8	301-6	7-4	32
Washer, Flat, USS, 3/8	301-6	7-6	33
Washer, Flat, USS, 3/8	301-6	7-12	18
Washer, Flat, USS, 3/8	301-6	7-24	11
Washer, Flat, USS, 3/8	301-6	7-47	26
Washer, Flat, USS, 3/8	301-6	7-48	26
Washer, Flat, USS, 3/8	301-6	7-52	8
Washer, Flat, USS, 5/16	301-5	7-17	6
Washer, Flat, USS, 5/16	301-5	7-18	4
Washer, Flat, USS, 5/8	301-10	7-4	12
Washer, Flat, USS, 7/16	301-7	7-27	8
Washer, Flat, USS, 9/16	301-9	7-7	6
Washer, Hardened, SAE, 1-1/2"	310-24	7-8	40
Washer, Lock, .500 Nord Wedge	986810	7-13	24
Washer, Lock, 1/2	302-8	7-1	15
Washer, Lock, 1/2	302-8	7-4	5
Washer, Lock, 1/2	302-8	7-6	43
Washer, Lock, 1/2	302-8	7-8	3
Washer, Lock, 1/2	302-8	7-16	14
Washer, Lock, 1/2	302-8	7-23	14
Washer, Lock, 1/2	302-8	7-27	20

Alphabetical Parts Index

Description	Part No.	Figure No.	Item No.
Washer, Lock, 1/2	302-8	7-41	10
Washer, Lock, 1/2	302-8	7-43	12
Washer, Lock, 1/2	302-8	7-47	13
Washer, Lock, 1/2	302-8	7-48	13
Washer, Lock, 1/2	302-8	7-50	9
Washer, Lock, 1/2	302-8	7-53	15
Washer, Lock, 1/2	302-8	7-62	8
Washer, Lock, 1/2	302-8	7-65	8
Washer, Lock, 1/2	302-8	7-66	8
Washer, Lock, 1/2	302-8	7-77	15
Washer, Lock, 1/4	302-4	7-2	11
Washer, Lock, 1/4	302-4	7-6	20
Washer, Lock, 1/4	302-4	7-27	4
Washer, Lock, 1/4	302-4	7-45	20
Washer, Lock, 1/4	302-4	7-60	18
Washer, Lock, 1/4	302-4	7-61	18
Washer, Lock, 1/4	302-4	7-69	8
Washer, Lock, 3/4	302-12	7-50	47
Washer, Lock, 3/8	302-6	7-3	17
Washer, Lock, 3/8	302-6	7-6	16
Washer, Lock, 3/8	302-6	7-8	54
Washer, Lock, 3/8	302-6	7-17	14
Washer, Lock, 3/8	302-6	7-18	13
Washer, Lock, 3/8	302-6	7-20	15
Washer, Lock, 3/8	302-6	7-23	11
Washer, Lock, 3/8	302-6	7-24	10
Washer, Lock, 3/8	302-6	7-32	20
Washer, Lock, 3/8	302-6	7-34	6
Washer, Lock, 3/8	302-6	7-35	6
Washer, Lock, 3/8	302-6	7-37	7
Washer, Lock, 3/8	302-6	7-38	7
Washer, Lock, 3/8	302-6	7-42	7
Washer, Lock, 3/8	302-6	7-47	6
Washer, Lock, 3/8	302-6	7-48	6
Washer, Lock, 3/8	302-6	7-50	17
Washer, Lock, 3/8	302-6	7-51	11
Washer, Lock, 3/8	302-6	7-52	7
Washer, Lock, 3/8	302-6	7-56	17
Washer, Lock, 3/8	302-6	7-57	22

Alphabetical Parts Index

Description	Part No.	Figure No.	Item No.
Washer, Lock, 3/8	302-6	7-58	13
Washer, Lock, 3/8	302-6	7-59	13
Washer, Lock, 3/8	302-6	7-60	17
Washer, Lock, 3/8	302-6	7-61	17
Washer, Lock, 3/8	302-6	7-63	7
Washer, Lock, 3/8	302-6	7-64	7
Washer, Lock, 3/8	302-6	7-77	6
Washer, Lock, 5/16	302-5	7-8	8
Washer, Lock, 5/16	302-5	7-17	5
Washer, Lock, 5/16	302-5	7-18	3
Washer, Lock, 5/16	302-5	7-19	18
Washer, Lock, 5/16	302-5	7-23	8
Washer, Lock, 5/16	302-5	7-27	16
Washer, Lock, 5/16	302-5	7-30	4
Washer, Lock, 5/16	302-5	7-37	10
Washer, Lock, 5/16	302-5	7-38	10
Washer, Lock, 5/16	302-5	7-39	13
Washer, Lock, 5/16	302-5	7-40	13
Washer, Lock, 5/16	302-5	7-47	56
Washer, Lock, 5/16	302-5	7-48	56
Washer, Lock, 5/16	302-5	7-50	14
Washer, Lock, 5/16	302-5	7-63	4
Washer, Lock, 5/16	302-5	7-64	4
Washer, Lock, 5/8	302-10	7-1	29
Washer, Lock, 5/8	302-10	7-2	20
Washer, Lock, 5/8	302-10	7-3	12
Washer, Lock, 5/8	302-10	7-4	13
Washer, Lock, 5/8	302-10	7-8	29
Washer, Lock, 5/8	302-10	7-44	6
Washer, Lock, 5/8	302-10	7-50	31
Washer, Lock, 5/8	302-10	7-67	6
Washer, Lock, 5/8	302-10	7-71	5
Washer, Lock, 5/8	302-10	7-77	19
Washer, Lock, 7/16	302-7	7-27	11
Washer, Lock, 7/8	302-14	7-47	10
Washer, Lock, 7/8	302-14	7-48	10
Washer, Lock, 8/16	302-5	7-10	19
Washer, Lock, 9/16	302-9	7-2	15
Washer, Lock, 9/16	302-9	7-4	21

Alphabetical Parts Index

Description	Part No.	Figure No.	Item No.
Washer, Lock, Hi-Collar, 1/2	307-8	7-6	25
Washer, Lock, Hi-Collar, 5/8	307-10	7-2	23
Washer, Lock, Hi-Collar, M10	307-M10	7-1	11
Washer, Lock, Hi-Collar, M12	307-M12	7-1	24
Washer, Lock, Hi-Collar, M12	307-M12	7-2	29
Washer, Lock, Hi-Collar, M16	307-M16	7-1	26
Washer, Lock, M10	302-M10	7-16	7
Washer, Lock, M12	300-M12	7-13	19
Washer, Lock, M12	302-M12	7-16	23
Washer, Lock, M16	302-M16	7-13	21
Water Tight Conduit Connector	1017228	7-45	5
Water Tight Connector, 1/2 x 1/2 MPT	3200DI	7-49	3
Water Tight Connector, 3/4 x 3/4 MPT	3400DI	7-24	7
Water Tight Connector, 3/4 x 3/4 MPT	3400DI	7-37	15
Water Tight Connector, 3/4 x 3/4 MPT	3400DI	7-38	15
Water Tight Connector, 3/4 x 3/4 MPT	3400DI	7-49	11
Water Tight Connector, 3/4 x 3/4 MPT	3400DI	7-63	13
Water Tight Connector, 3/4 x 3/4 MPT	3400DI	7-64	13
Water Tight Connector, 3/4" x 3/4"	3400DI	7-53	27
Watlow Temperature Harness	1017774	7-29	REF
Wear Plate Assembly	987216SRV	7-56	7
Wear Plate Assembly	987216SRV	7-57	13
Wear Plate Spacer	1007001	7-33	2
Wear Plate w/Studs, 3/8"	1016475	7-33	1
Wedglock Connecor, W3P	983211	7-29	27
Wedglock Connector, W3P	983211	7-28	29
Weldment, Adjustable Slide Bar	1002305	7-75	17
Weldment, Front Brace, 40' Ski	1002302	7-75	11
Weldment, Front Slide Bar Housing	851243LSRV	7-74	11
Weldment, Front Slide Bar Housing	851243RSRV	7-74	12
Weldment, Front Slide Bar Housing (Left)	851243LSRV	7-75	15
Weldment, Front Slide Bar Housing (Right)	851243RSRV	7-75	16
Weldment, Rear Brace, 40' Ski	1002311	7-75	10
Weldment, Rear Slide Bar Housing	851241LSRV	7-74	16
Weldment, Rear Slide Bar Housing	851241RSRV	7-74	15
Weldment, Rear Slide Bar Housing (Left)	851241LSRV	7-75	20
Weldment, Rear Slide Bar Housing (Right)	851241RSRV	7-75	19
Weldment, Ski Support Front Arm, 40'	1002300	7-75	14
Weldment, Ski Support Rear Arm, 40'	1002301	7-75	21

Alphabetical Parts Index

Description	Part No.	Figure No.	Item No.
Weldment, Skid	851249SRV	7-75	1
White Seat Assembly w/Armrest	360010	7-30	1
Wing Nut, 3/8-16	212-6-16	7-75	9
Wing Screw, Type C, 3/8-16 x 1.00, Cup	120-6-16	7-26	8

Illustrated Parts List

NOTES

LeeBoy



VT LeeBoy

A company of VT Systems

500 Lincoln County Parkway Ext.

Lincolnton, North Carolina 28092

Phone: (704) 966-3300 - Fax Sales: (704) 483-5802

www.LeeBoy.com

Printed in the U.S.A.